



Wachusett Brewing Company Process Heat Exchanger Feasibility Study

**A Major Qualifying Project Report
Submitted to the Faculty of**

WORCESTER POLYTECHNIC INSTITUTE

**In partial fulfillment of the requirements for the degree of
Bachelor of Science in the field of Chemical Engineering**

**Sponsored by:
Wachusett Brewing Company
175 State Rd. E
Westminster, MA 01473**

Authors:

**Brian Bach
Tyler DeFosse
Brian Splaine**

Advised by:

Professor Stephen Kmietek

This report represents the work of WPI undergraduate students submitted to the faculty as evidence of completion of a degree requirement. WPI routinely publishes these reports on its website without editorial or peer review. For more information about the projects program at WPI, please see <http://www.wpi.edu/academics/ugradstudies/project-learning.html>

Table of Contents

Table of Contents	i
Abstract	iii
1.0 Introduction.....	1
2.0 Background	2
2.1 Process Heat Exchange Overview.....	2
2.2 How Heat Exchangers Work.....	3
2.3 Materials Information.....	5
2.4 Controls	7
3.0 Methodology and Results	8
3.1 Assess Current Systems	8
3.1.1 Sketch of Current System	8
3.1.2 Stream and Equipment Data	10
3.2 Determining Feasibility of Creating a New Heat Exchanger System.....	13
3.2.1 Assessment of Carbon Dioxide as a Refrigerant	13
3.2.2 Aspen Plus Simulations	14
3.2.3 Design of the Exchanger Network.....	14
3.2.4 Design of the Heat Exchanger	18
3.2.5 Site Plan	21
3.2.6 HAZOP	22
3.2.7 Process Controls	23
3.2.8 Required Equipment and Modifications.....	26
3.3 Economic Feasibility.....	29
3.3.1 Determining Cost of Equipment.....	29
3.3.2 Determining Total Savings.....	29
4.0 Conclusions and Recommendations	31
References.....	32
Appendices.....	34
A. Carbon Dioxide System	34

A.1 Calculation of Average Carbon Dioxide Usage	34
A.2 Determining Temperature of Saturated Liquid CO ₂	36
A.3 Carbon Dioxide Properties:	36
B. Propylene Glycol System	37
C. Process Flow Diagram Table of Stream Data	38
D. Aspen Input File	39
E. Calculating Area of Heat Exchanger	42
E.1 Calculation of ΔTLM	42
E.2 Correction Factor for Multiple Pass Exchangers	43
E.3 Calculation of Heat Transfer Coefficient:.....	44
E.4 Calculation of Areas Required	45
E.5 Determining Number of Tubes Required.....	45
F. Heat Exchanger Data Sheet.....	47
G. HAZOP Study	48
H. Sizing of New Pipes	55
I. Calculating Shaft Power of the Pump:.....	57
J. CAPCOST Inputs:	58
K. Determining Cost of the Heat Exchanger:	59
L. Determining Cost of the Pumps:.....	60
M. Refrigeration Efficiency Calculation:	61
N. Return On Investment	62
N.1 Operating Cost per Pound of Glycol	62
N.2 Annual Operating Cost	62
N.3 Total Savings	62
N.4 Payback Period	63

Abstract

The Wachusett Brewing Company utilizes a propylene glycol coolant loop to chill their beer. This coolant loop requires the use of refrigeration units. The brewery also has a carbon dioxide bulk storage tank which is in reasonable proximity to the glycol storage vessel. A Wachusett Brewery representative approached our team with the idea of installing a process heat exchanger between the two systems as a cost saving mechanism. The team proceeded to evaluate the physical and economic feasibility of constructing such a system. Upon determining that the system could be built, the team designed a control system and priced the exchanger and ancillary equipment. The team then recommended that Wachusett Brewing Company consider constructing the system based upon the outcome of our analysis.

1.0 Introduction

Wachusett Brewing Company, much like other breweries and beverage manufacturers, is reliant upon the efficient use of the carbon dioxide and cooling systems to help create products for relatively low costs. On average, Wachusett Brewing Company uses approximately 1,800,000 pounds of carbon dioxide a year in deoxygenating and carbonating steps of the process, and it is also commonly used to purge lines and tanks. Additionally, Wachusett Brewing Company uses a mixture of propylene glycol and water for much of their cooling throughout the facility to achieve desired vessel and mixture temperatures. In order to maintain a similar rate of production, the facility has to run using the correct flow rates of carbon dioxide and propylene glycol, and thus it is especially important that the system is running as smoothly and efficiently as possible.

To help ensure this, a group of Worcester Polytechnic Institute (WPI) students have assessed the current carbon dioxide and propylene glycol systems. They have found that there is room for improvement between the two respective systems and that utility cost can be minimized. The carbon dioxide that is used in the process originally comes from a pressurized liquid carbon dioxide tank at 300 psig and 1.5°F. The propylene glycol mixture that is used throughout the facility is kept at 24°F through a refrigeration system. Through the implementation of a heat exchanger network between the carbon dioxide and propylene glycol systems, the operating cost of propylene glycol can be reduced while still yielding temperatures in the appropriate range.

The goal of this project was to assess the current heat exchange processes for glycol and carbon dioxide systems at Wachusett Brewing Company and recommend improvements. There have been several issues noted with the current setup that have led to unnecessary heat loss and an increased utility cost that could potentially be minimized if configured appropriately.

There were three main components in completing this study for Wachusett Brewing Company. First, both qualitative and quantitative assessments of the current equipment and utility usage were conducted to gain an understanding of the effectiveness of the current setup. From the data collected, it was determined that a heat exchanger network should be developed in order to maximize heat recovery and minimize utility cost for this section of the brewery. The team then performed an economic feasibility study to determine if the proposed heat exchanger network would be profitable for Wachusett Brewing Company.

2.0 Background

2.1 Process Heat Exchange Overview

Process heat exchange is used as a cost-saving measure in industry. When one stream needs to be cooled or heated, a cooling or heating fluid can be used to bring the stream to the desired temperature. If two streams need to be simultaneously cooled and heated, however, a process heat exchanger can be built to bring both streams to their desired temperatures. In this manner, less coolant or hot fluid would be needed to cool down or heat up the streams in question, thus reducing the utility burden, and thus costs, of these fluids.

2.2 How Heat Exchangers Work

There are several different types of heat exchangers with their own unique exchange styles, but nearly all exchangers utilize the same general method of heat transfer. Essentially, a hot stream is placed in proximity to a colder stream, usually through a series of pipes and baffles, and heat transfers between the streams, cooling the hot stream and heating the cold stream to the desired temperature. This can be done through designing the exchanger to either have fluid flow in a cocurrent or countercurrent fashion. It is commonly known that countercurrent flow helps yield a higher driving force for heat transfer between two liquids, and as a result most systems are designed this way as it minimizes the required size of the exchanger. In addition to choosing countercurrent flow over cocurrent, other measures can be taken to increase the amount of heat transfer in a system. For example, baffles aid heat transfer by increasing the surface area for transfer and creating a tortuous path which facilitates mixing and accelerates heat transfer.

There are several types of exchangers, and each type has certain benefits and drawbacks, so it is necessary to look at all aspects of the exchanger before selecting one for a particular project. Shell and tube heat exchangers are one of the most commonly used types of heat exchangers in industry.¹ In this model, a shell is filled with several small tubes that are often close to the length of the exchanger, where one fluid flows through the tubes while the other flows outside of the tubes. In order to maximize heat transfer efficiency, the flows are often set up to go in a countercurrent fashion as this yields a higher potential heat duty due to a higher average driving force. Shell and tube exchangers can be single or multipass.² Multipass exchangers allow for more contact time between fluids, enabling more overall heat transfer via an increased log mean temperature driving force. Figure 1 below illustrates a typical shell and tube heat exchanger.

¹ "Heat Exchanger Type Selection." Heat Exchanger Type Selection. H&C Heat Transfer Solutions, n.d. Web. 07 Feb. 2017.

² Turton, Richard, et al. (2003) *Analysis, Synthesis, and Design of Chemical Processes*, Upper Saddle River, NJ: Prentice Hall

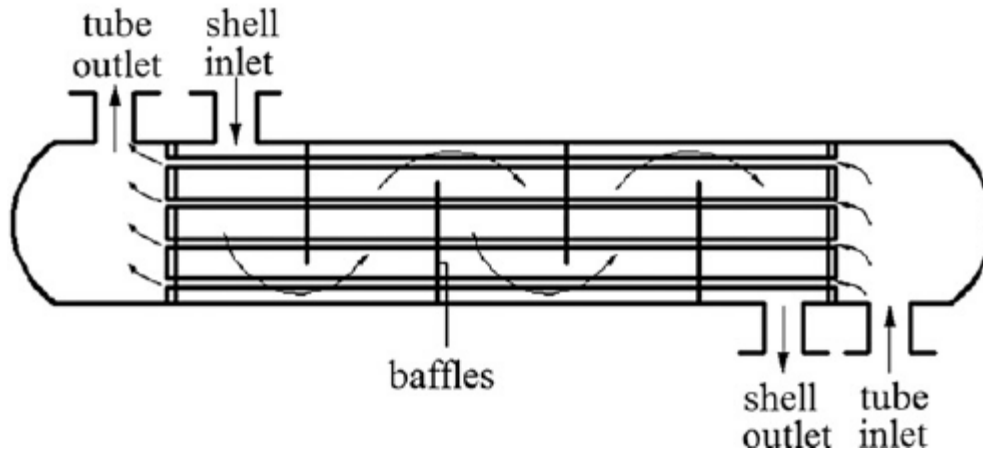

Figure 1: Single pass shell and tube heat exchanger³

When using a shell and tube heat exchanger, it is important to know which liquid will be flowing on the tube side of the exchanger and which will be flowing on the shell side. In order to minimize cost, if a fluid is corrosive or at a very high pressure then it should be passed through the tube side. This ensures that the expensive thick walls or corrosion-resistant materials are only necessary for the tubes and tube heads. Also, since the tubes are replaceable, it is cheaper to replace damaged tubes than the entire exchanger if the shell is damaged.

³ Hadidi, Amin, and Ali Nazari. Diagram of a typical shell and tube heat exchanger. Digital image. ResearchGate. ResearchGate, Jan. 2013. Web. 28 Feb. 2017.

2.3 Materials Information

Propylene glycol is commonly used in the food and beverage industry as a coolant as it is a food grade antifreeze. This is a type of antifreeze used when a food product needs to be cooled. Propylene glycol is often mixed with another substance such as water in order to change its freezing point and specific heat to perform better in different scenarios.⁴

When using a glycol-based solution, it is important to determine whether propylene or ethylene glycol is more beneficial for the process. Ethylene glycol is ideal for many industrial applications due to its superior heat transfer efficiency, however it is not the safest option. For many food processing or brewery-type applications, propylene glycol is the better choice due to its lower toxicity. If ethylene glycol leaked into drinking water or came into contact with parts of the process that may be ingested, it would be hazardous and potentially fatal. The US Food and Drug Administration categorizes propylene glycol as Generally Recognized As Safe (GRAS); thus, “[it] can be used in immersion of freezing wrapped foods and other applications where ethylene glycol is not permitted.”⁵

Liquid carbon dioxide has a variety of applications in industry. Most commonly, it can be used as a refrigerant in food processing and production. This is similar to solid carbon dioxide (dry ice) which is mainly used to freeze foods or keep them frozen during transport and processing. Liquid CO₂ is not immensely dangerous, the main hazards being possible frostbite or suffocation through displacing oxygen. Although it is not innately hazardous, the CO₂ generally needs to be stored in a pressurized tank in order to remain in liquid form. The high pressure of the tank itself presents some dangers, particularly possible explosion if heated.

Aspen Plus is recognized as an effective chemical engineering simulation program that is used widely in industry to predict the outcome of various chemical engineering processes. It has several capabilities including distillation, gas absorption, heat exchanger design, and thermochemical data

⁴ VanderGiessen, Jim, Jr. "ProBrewer.com." ProBrewercom. Pro Refrigeration Inc., n.d. Web. 07 Feb. 2017.

⁵ "Ethylene vs Propylene Glycol." Ethylene vs Propylene Glycol | Heat Transfer Fluids | The Dow Chemic. The DOW Chemical Company, n.d. Web. 07 Feb. 2017.

prediction. The team utilized Aspen Plus V 8.8 to predict and provide all relevant thermochemical data utilizing the UNIFAC property method. In the example of heat exchangers, the user can input several variables such as the feed temperatures, heat duties, compositions, and flow rates of various materials that are to be considered. The output values that are given can then be noted and inputs can be narrowed down to achieve the desired output. For example, in the case of a heat exchanger consisting of a saturated liquid and a hot stream at a given temperature and composition, flow rates can be manipulated until the desired outlet temperature of the stream of interest is met. In addition to determining the amount of liquids that can be pumped through the exchanger to achieve these values, Aspen Plus also gives the heat duty of the exchanger and the amount of surface area that is required for heat transfer to occur. This sort of software could be useful for companies such as Wachusett Brewery when evaluating data about carbon dioxide and glycol usage.

2.4 Controls

Process controls allow one to regulate a process to perform as designed even when there are environmental perturbations. For instance, consider the outlet stream of a thermal mixing tank with a temperature indicator on the stream. The process will require a specified temperature for said stream and the temperature indicator can indicate to a controller what the current temperature of the stream is. From this information, the controller can take appropriate corrective action should the temperature be too warm. This action could be to activate a variable speed pump and send the fluid from the thermal mixing tank to a refrigeration unit. This unit will then reduce the temperature of the fluid allowing for the setpoint temperature to be reacquired. The deviation in temperature could be due to daily fluctuations in the ambient temperature. Without the control system described, the thermal mixing tank will be uncontrolled and be susceptible to the natural fluctuations in temperature of the environment, which can impact other aspects of the process.

Controllers work by comparing a measured process variable to a desired value. The controller then takes the difference between these values as an error function and takes the requisite action to make the error function equivalent to zero. The requisite action is dictated by the type of controller selected for regulating the process. Proportional controllers (P controllers) use a proportional gain constant to restore the system to steady state. This constant is multiplied by the error function and will enable the system to approach the desired steady state value. One caveat of P-control is that the steady state cannot be exactly reached, but can be nearly achieved by the selection of an appropriate proportional gain constant. Proportional Integral controllers (PI controllers) use the proportional gain constant as well as an integral term which sums the total error that has occurred since the system was activated. There is also an integral time constant which allows for choosing how much impact the integral term has. These controllers are more expensive, but they do allow for a steady state setpoint to be accurately reached. The final type of controller is the Proportional Integral Derivative (PID) controller. This controller uses the same controller principles as the PI controller, but adds a derivative term which estimates the rate of change of the error and enables the response to accelerate or retard as required.⁶

⁶ Stephanopoulos, George. *Chemical Process Control An Introduction to Theory and Practice*. New Jersey: Prentice Hall, 1984. Print.

3.0 Methodology and Results

This section of the document contains the various methods that the group executed to collect valuable pieces of data, as well as the associated pertinent information that went with it. We then took the acquired data and utilized it along with assumptions where data was not available to design a process heat exchange network for the Wachusett Brewing Company.

3.1 Assess Current Systems

Wachusett Brewing Company has a propylene glycol coolant system and a carbon dioxide bulk storage unit in reasonable proximity to each other. The glycol system is utilized to chill the beer while the carbon dioxide is used in a variety of fashions throughout the plant in its vapor form. The bulk storage tank stores the carbon dioxide as a liquid and needs to have the liquid expand into a vapor in order for it to be used. The team noted that there was $\frac{3}{4}$ inch ice surrounding a sizable length of pipe leaving the liquid carbon dioxide tank. This is known to be an energy waste as the cooling potential of the carbon dioxide is being given to the surroundings, cooling the water in the air in the form of ice on the pipe, which is not particularly useful for any of the processes. In order to keep the glycol chilled, there is a glycol tank cooled by a 50 ton and a 40 ton refrigeration system. These systems require the use of electric power to chill the glycol which is a sizable operating cost. Due to the proximity to the carbon dioxide system, in addition to the waste of cooling power and the operating cost of the refrigeration systems, Quality Assurance Manager Cullen Dwyer suggested that process heat exchange between the two systems might be possible. The focus of this assessment is to note the features of the two systems in order to determine if they are compatible for being utilized in a heat exchanger network.

3.1.1 Sketch of Current System

The team began by taking field observations of the current layout of this section of the brewery in order to gain an understanding of the carbon dioxide and glycol systems. Figures 2 and 3 represent the current glycol and carbon dioxide systems that are in place.

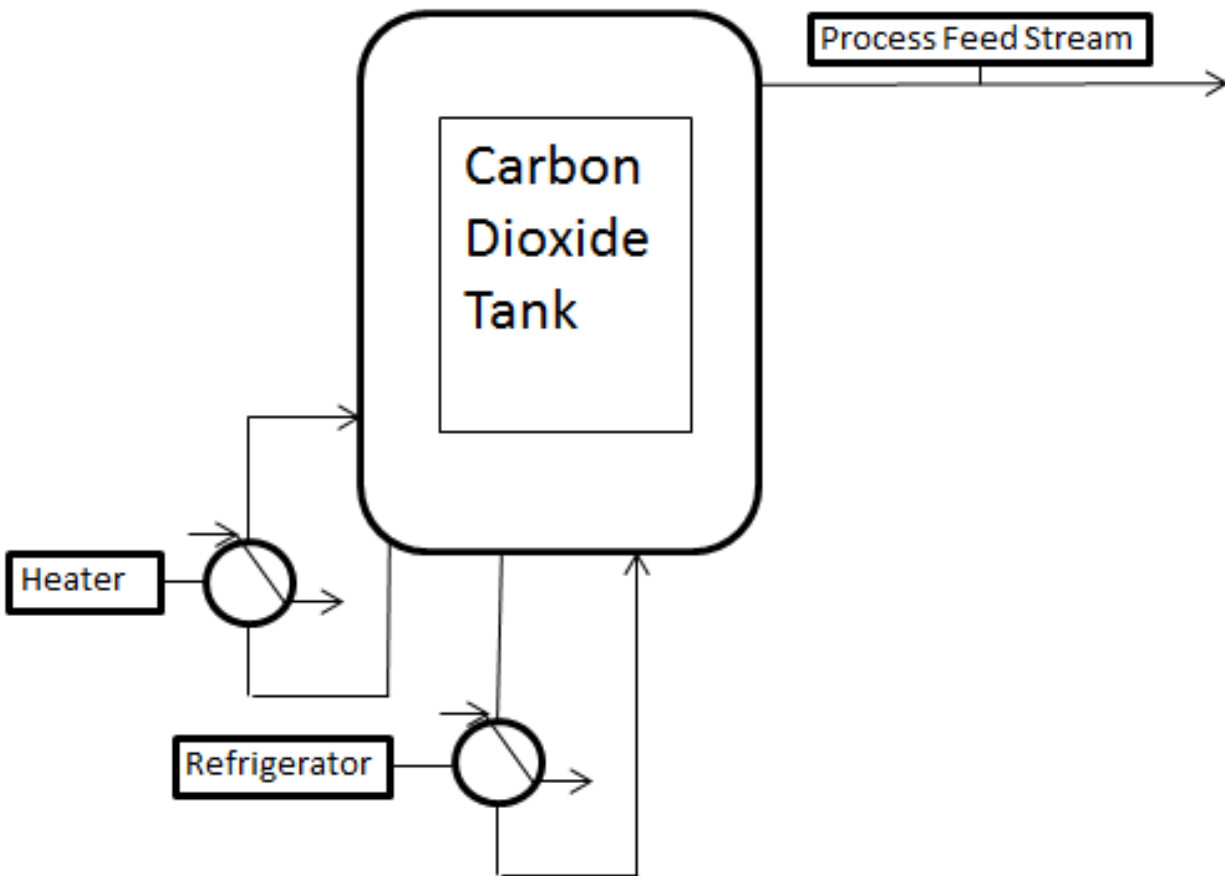

Figure 2: Current carbon dioxide system

The carbon dioxide system consists of a bulk storage tank, as well as an electric heater and refrigeration loop. The tank has a pressure setpoint of 300 psig and is kept at this pressure by the refrigeration and heating units. When the tank pressure gets too low, some carbon dioxide leaves the vessel and enters an electric heater; conversely, the refrigerator cools the carbon dioxide whenever the pressure gets too high. The CO₂ in the tank is in vapor-liquid equilibrium with vapor at the top of the tank and liquid at the bottom. Currently, there is only one line carrying carbon dioxide out of the tank. To flow to the process, the vapor at the top of the tank enters a pipe, which is above the liquid level, and then follows the pipe down and out of the tank. This pipe is the only outlet pipe connected to the CO₂ tank; that is, no line currently exists to carry liquid carbon dioxide out of the tank to process.

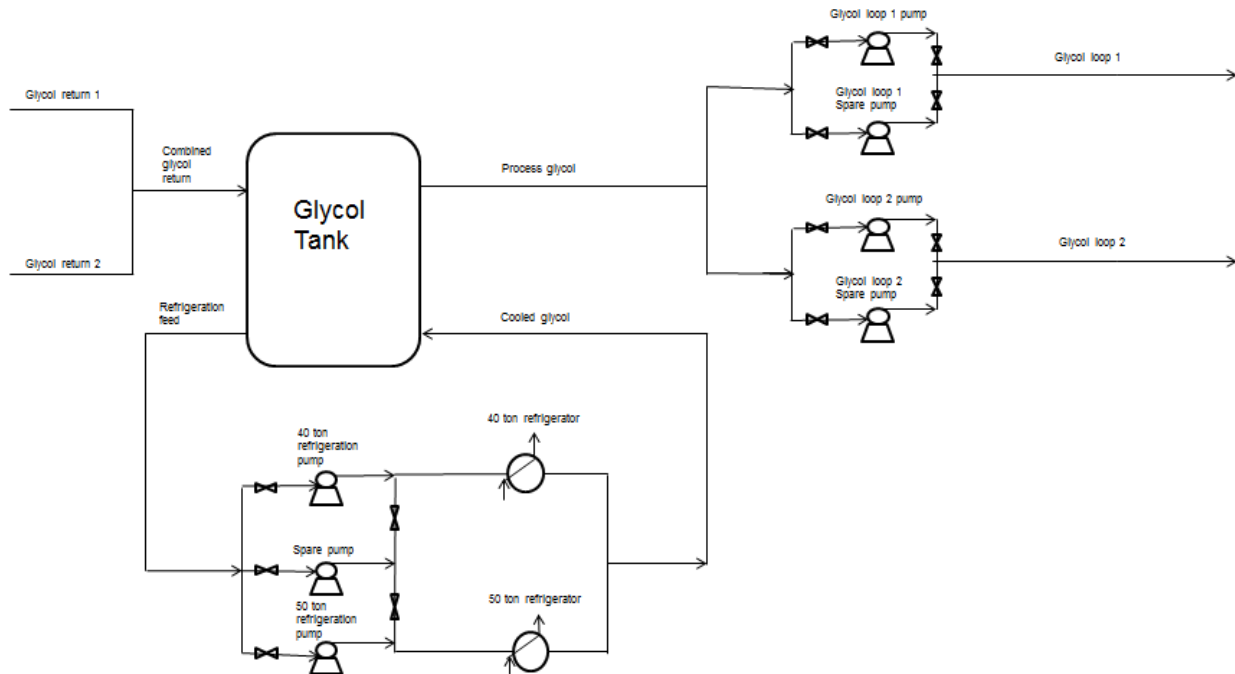

Figure 3: Current propylene glycol system

The glycol system is centered around a 1700 gallon glycol tank, which has two process return streams that combine and enter the tank. The glycol that goes to process is maintained at approximately 24°F by the refrigeration loop that consists of a 40 or 50 ton refrigerator. If a process unit needs to be chilled, the pumps activate, pumping glycol to process.

3.1.2 Stream and Equipment Data

In order to obtain information about the typical operating conditions of the facility, several tactics of data collection were administered. First, the team measured the sizes of pipes in the related areas of the facility with a caliper and measuring tape to the nearest 1/8 inch. Additionally, the team measured the thickness of ice surrounding the pipes near the glycol and carbon dioxide tank to approximately 3/4 to 1 inch. Through visual inspection and verbal communication with Maintenance Mechanic Dan Hagelberg, it was determined that the pipes around the glycol tank were schedule 10 while pipes surrounding the carbon dioxide system were schedule 40. Mr. Hagelberg additionally provided the team with other useful information including pressure outputs of pumps, size and type of vessels and equipment, including thickness and insulation, as well as the typical frequency of carbon dioxide and propylene glycol usage throughout the system.

It was important to determine the flow rates of all of the liquids and gases in our area of interest, especially carbon dioxide and propylene glycol. Average hourly carbon dioxide flow rates were calculated to be 12 lb/min based on the documentation of liquid CO₂ deliveries provided by Cullen Dwyer. This calculation was made based on the assumptions that the plant is operating 8 hours per day, 5 days per week, and that the consumption is approximately the same during all months of the year. To account for a variation in carbon dioxide demand, the average flow rate was doubled to 24 lb/min for the purposes of engineering a safe system that still accomplishes the desired tasks. See Appendix A for detailed calculations.

The maximum flow rate of propylene glycol throughout the system assuming full operation of current refrigeration systems was calculated through the use of a material and energy balance around the propylene glycol tank. Figure 4 below represents the streams entering and leaving the glycol tank.



Figure 4: Glycol tank material balance

	Stream 1	Stream 2	Stream 3	Stream 4
Description	Process Return	Refrigeration Feed	Refrigeration Return	Process Feed
Mass flowrate (lb/min)	N/A	3,199	3,199	N/A
Temperature (°F)	30	28	20	24

Table 1: Inlets and outlets of glycol tank

The temperatures of the propylene glycol pipes leaving the tank (Streams 2 & 4) were read off temperature gauges. The temperature of the glycol returning from process (Stream 1) was approximated to be 30°F because it used to chill the beer to 32°F and the temperature needs to be lower for cooling potential. Additionally, the temperature of the returning glycol from the

refrigeration system (Stream 3) was approximated to be 20°F, as the temperature must be lower than the 24°F required for process. Using the capacity of each of the refrigeration units, a simple calculation was performed to determine the heat duty of each system (Appendix B). Knowing the temperatures of the propylene glycol before and after refrigeration, along with the refrigeration heat duty, a calculation of the maximum mass flow rate of the glycol-water mixture was completed using the specific heat formula:

$$\dot{Q} = \dot{m}c_p \Delta T$$

Assuming the current refrigerators were running at full capacity at all times, the maximum mass flow rate of glycol in the system would be roughly 3,200 lb/min (Appendix B). However, it is known that both of the existing refrigeration systems are typically not running at full capacity, and thus the actual amount of glycol running through the system is much lower.

To determine if the system had any other flow limitations, the team considered maximum flow the pipes can withstand as well as the maximum flow capacity of the pumps. It is known that Wachusett Brewing Company is currently using two inch schedule 10 piping around the glycol tank, with no experience of noise coming from the pipes. Based on this information, the team used a maximum pipe velocity of 10 ft/s to determine that the maximum mass flow rate throughout pipes is 965 lb/min.⁷ The team believes that this number is more realistic to the operating conditions at the brewery than the flow rate determined through the specific heat formula, so this number was used as a reference when designing the heat exchanger system. The team was informed by Mr. Hagelberg that the pumps have a maximum capacity of 350 gallons per minute, which is equal to 2965 lb propylene glycol solution/min, higher than the assumed maximum flow through the pipes. Thus the limiting maximum flow rate would be the 965 lb/min of propylene glycol solution.

⁷"Maximum Flow Velocities in Water Systems." The Engineering ToolBox. N.p., n.d. Web. 12 Feb. 2017.

3.2 Determining Feasibility of Creating a New Heat Exchanger System

Once the current propylene glycol and carbon dioxide systems were assessed, the basics of designing a new heat exchanger could be determined. Assessment of the current system allowed the team to acquire data for the maximum flow scenario, which was then used in the following calculations to determine the feasibility of creating the new heat exchanger system.

3.2.1 Assessment of Carbon Dioxide as a Refrigerant

In order to design the heat exchanger, the ability of carbon dioxide as a coolant had to be determined. When calculating the heat exchanger's ability to cool the glycol down to the required temperature, it was found that the temperature difference between the CO₂ and the glycol was fairly small. Specifically, the glycol mixture starts at a temperature of 28°F and needs to be cooled down to 20°F, which would cool the tank to the required effluent temperature of 24°F. Assuming the liquid CO₂ is saturated, it has a temperature of 1.5°F. While the relatively small temperature difference would ordinarily not provide much driving force for heat transfer, the carbon dioxide will act as an effective refrigerant in this scenario as it is starting in the phase change region, and energy added will go into vaporization. In industrial practice, refrigerants are most effective when the log mean temperature difference between the refrigerant and the other stream is greater than 10°F.⁸

It is known that more heat is available to transfer when a phase change occurs rather than merely a temperature differential between a hot and a cold stream. This is due to the fact that the energy required to vaporize a substance is generally much greater than the energy needed to simply change the temperature of the substance. Hence, exploiting the latent heat of vaporization for CO₂ was expected to provide much better heat transfer than relying on the specific heat capacity of liquid or vaporous carbon dioxide. Taking this into account, it was presumed that a CO₂ effluent stream with a vapor fraction of 1 would provide the best heat transfer. For this reason, CO₂ and glycol flow rates which would result in a CO₂ vapor fraction of 1 were used in the following Aspen Plus simulations.

⁸ Turton, Richard, et al. (2003) *Analysis, Synthesis, and Design of Chemical Processes*, Upper Saddle River, NJ: Prentice Hall

3.2.2 Aspen Plus Simulations

The simulations were conducted under the assumption that the process glycol stream leaving the tank is always required to be at 24°F. In order to achieve that, the feed stream to the exchanger was given a value of 28°F and post refrigeration was 20°F. It was also assumed that the carbon dioxide leaving the storage tank and entering the other side of the exchanger was a saturated liquid at 1.5°F at 300 psig. An average carbon dioxide flow rate of 24 lb/min was used through assuming a constant usage over an 8 hour day to model typical usage. These specifications were held constant because they were determined to be required for the new heat exchanger system to not change any process usage while still allowing maximum heat transfer.

Upon running these simulations, the team noticed that a total flow rate of 510 lb/min of glycol would be required to vaporize the 24 lb/min of carbon dioxide in a maximum flow scenario. As previously noted in this report, the current refrigeration systems have a maximum glycol flow rate of 965 lb/min. The team therefore determined that it would be feasible to use 510 lb/min as a glycol flow rate as this was below the calculated maximum. Thus, the team then began investigating potential heat exchanger networks.

3.2.3 Design of the Exchanger Network

After determining that carbon dioxide was feasible as a refrigerant and the required flow rates for carbon dioxide and propylene glycol were realistic, the group then began to design the heat exchanger network and the required peripherals for the process heat exchange. There were two major ways in which the group determined the network could be built.

The first option that the team discussed with representatives from Wachusett Brewing Company was to have the heat exchange occur inside of the glycol tank. This method would require draining of the glycol tank and cutting into the tank to place the necessary equipment within it. This would necessitate shutting the system down for possibly many workdays, which would result in a large production reduction. Tanks, which have been cut into, according to Stephen J. Kmiolek, PhD, P.E., tend to leak, which will result in a loss of propylene glycol and thus wasting energy for having cooled this lost glycol.

The second method was to construct an external heat exchanger that would be built between the propylene glycol and carbon dioxide systems. This was thought to be more desirable as it would require minimal time for plant shutdown and the glycol tank would also be left untouched. This system would allow for better cooling than feeding CO₂ through stagnant glycol because two fluids flowing past each other in a countercurrent fashion will have a higher potential for heat transfer. With these considerations in mind, the team opted to design an external heat exchanger which could be attached to the current system.

3.2.3.1 Determining optimal process

In order to determine the most optimal process design for this heat exchanger network, the team proposed a variety of possible avenues to pursue and considered the implications of each design.

One possible scenario included continuously running the process without carbon dioxide recycle back to the storage tank, where the vaporized carbon dioxide would be dealt with in a variety of ways including: venting to the atmosphere, selling to a nearby company, or storing in solid or liquid form (i.e. calcium carbonate or carbonated water) to be extracted when needed. None of these options were determined to be reasonable.

Venting to the atmosphere would cause significant carbon dioxide emissions and would be a waste of a useful resource. The idea of selling carbon dioxide to a nearby company could be beneficial for both parties, but this option depends on the demand of nearby companies for carbon dioxide. The transport required, as well as the unpredictability of nearby companies' demands, caused this option to be too unreliable and troublesome to pursue. Storing the carbon dioxide in solid or liquid form is also a plausible concept, but there would need to be a reaction or some work input to extract the carbon dioxide from the solid or liquid when it is needed. This observation, along with the fact that the solid or liquid would need a separate storage tank, makes this option neither time nor cost effective. After analyzing these options, the team determined that any scenario involving continuously running the process without a recycle stream is not in Wachusett Brewing Company's best interest to pursue.

A second scenario considered was running the system continuously, and instead returning the vaporized carbon dioxide back to the bulk storage tank. In doing so, the carbon dioxide would continuously pressurize the tank unless it was recondensed. However, cooling back to the liquid phase shifts the refrigeration burden from the glycol refrigeration unit to the bulk storage tank refrigeration unit. This defeats the purpose of the proposed heat exchanger as utility cost would simply be transferred and the capital investment in the unit would never be made back. These facts eliminated this idea from contention.

The third scenario, which the team determined to ultimately pursue, required that the proposed heat exchanger only be used at times when carbon dioxide is required for process purposes. In every other way, it is similar to the previous scenario in which the liquid CO₂ is taken from the tank and sent through a heat exchanger to cool the glycol. However, instead of returning some vapor carbon dioxide back to that tank, all of the CO₂ from the exchanger is to be sent to process.

This design does not shift the refrigeration burden from one unit to another, nor does it require creative CO₂ usage as outlined previously. In fact, in this design, none of the CO₂ will be returned to the tank at all. Therefore, it is not necessary to recondense any of the CO₂ and the current refrigeration loop on the tank can maintain its sole purpose as a pressure regulator for the carbon dioxide already in the tank. This design also does not hinder the usage of the carbon dioxide and allows for the energy requirements for vapor expansion to come from a useful source and not the environment. This keeps the glycol at the appropriate process temperature and reduces the refrigeration cost while also maintaining the necessary CO₂ flows for all of the plant processes. This method also assures that no CO₂ is wasted because it is only being used when required. For all of the aforementioned reasons, it was decided that this design was the most reasonable and beneficial for the needs of Wachusett Brewing Company.

The Process Flow Diagram in Figure 5 below highlights how this process works.

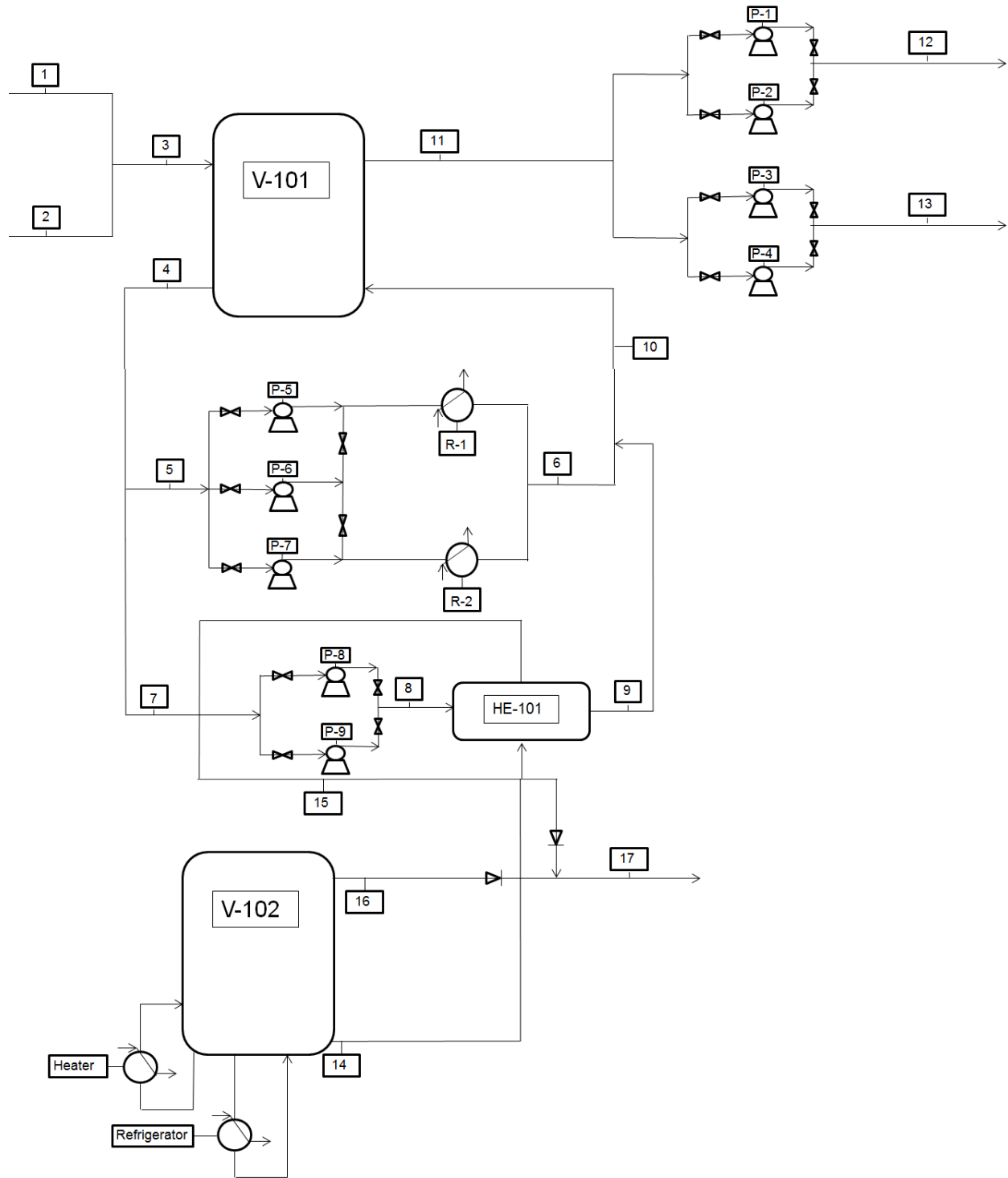

Figure 5: Process Flow Diagram for Proposed Heat Exchanger

In this orientation, Streams 1 and 2 represent the returning glycol streams from process, which combine together to create Stream 3 that enters back into the storage vessel (V-101). The glycol exits the tank at approximately 30°F through Stream 4, which then splits into Streams 5 and 7 where Stream 5 is the feed to the current refrigeration systems (R-1 & R-2), and Stream 7 is the feed to the proposed process heat exchanger (HE-101). These streams are then pumped up to pressure by the centrifugal pumps prior to the refrigerators and process heat exchanger. The cooled glycol then leaves the refrigerator and heat exchanger systems at approximately 20°F in Streams 6 and 9, respectively. Streams 6 and 9 combine together to create Stream 10, which returns to the storage tank and mixes with the other glycol in the tank. The mixed glycol then leaves the tank via stream 11 at 24°F and is then split into the two process streams 12 and 13 to be used as a coolant throughout the facility.

The lower region of Figure 5 depicts the carbon dioxide storage vessel (V-102) where liquid carbon dioxide is stored and is in equilibrium with vapor carbon dioxide at 300 psig. Liquid carbon dioxide leaves through the bottom of the vessel in Stream 14 and is sent to the process heat exchanger (HE-101) to be used as a coolant for the glycol as mentioned previously. As a result of cooling the glycol, the carbon dioxide is heated up and leaves the exchanger as a vapor in Stream 15. This stream then combines with any additional vapor carbon dioxide needed (Stream 16) to create Stream 17 that is ultimately sent to process and distributed as needed.

A table of values for these streams under maximum flow scenario can be seen in Appendix C.

3.2.4 Design of the Heat Exchanger

Knowing that the exchanger was going to be in a high traffic area, the team wanted it to have the smallest footprint possible. This resulted in the decision to make a vertical heat exchanger. To ensure the exchanger could handle the required pressures, a bonnet type exchanger was chosen for its strength. To ensure complete countercurrent flow, a U-tube exchanger with a longitudinal baffle was selected. These selections are indicative of the BFU TEMA type.⁹ The exchanger was also

⁹ "TEMA Designations of Heat Exchangers." Wermac, n.d. Web. 28 Feb. 2017.

designed for the maximum flow scenario of double the average carbon dioxide process demand. This ensures the exchanger can handle fluctuations in demand. We also selected the carbon dioxide to be on the tube side of the exchanger because a high pressure fluid should be on the tube side as it will minimize construction and maintenance costs.¹⁰

To design the heat exchanger, the team took property data from Aspen Plus for each of the involved chemical species. Using the UNIFAC property method, the latent heat of vaporization and the specific heat for gaseous carbon dioxide were taken along with the specific heat of the propylene glycol-water mixture. As mentioned above, the feed temperature of the propylene glycol to the exchanger was approximated to be 28°F. Based on the Aspen Plus simulation, it was also known that the temperature of saturated liquid carbon dioxide at 300 psig would be 1.5°F. To ensure total vaporization of the carbon dioxide, we designed for the outlet temperature of the carbon dioxide stream to be at 9°F. Since we had both a phase change and temperature change region in our heat exchanger, we had to approximate it as two heat exchangers in series in order to accurately design it. The overall outlet temperatures of both pseudo exchangers were calculated by taking the overall heat duty for both exchangers and dividing by the product of the mass flow rate of the glycol and the specific heat of the glycol. Now knowing the outlet temperature of the exchanger was 19.76°F, we solved for the inlet temperature of the “carbon dioxide phase change exchanger.” This was done by taking the duty of this exchanger and setting it equal to the product of the mass flow rate, specific heat, and temperature change of the glycol. Solving for the temperature change and adding the outlet temperature to the change resulted in the inlet temperature of 27.87°F. This would also be the temperature of the outlet of the “carbon dioxide temperature increase exchanger,” as seen in Figure 6. The input file for the Aspen Plus simulations can be found in Appendix D.

¹⁰ Sloley, Andrew. "Shell-and-Tube Heat Exchanger: Pick the Right Side." *Chemical Processing*. N.p., 23 Oct. 2013. Web. 07 Feb. 2017.

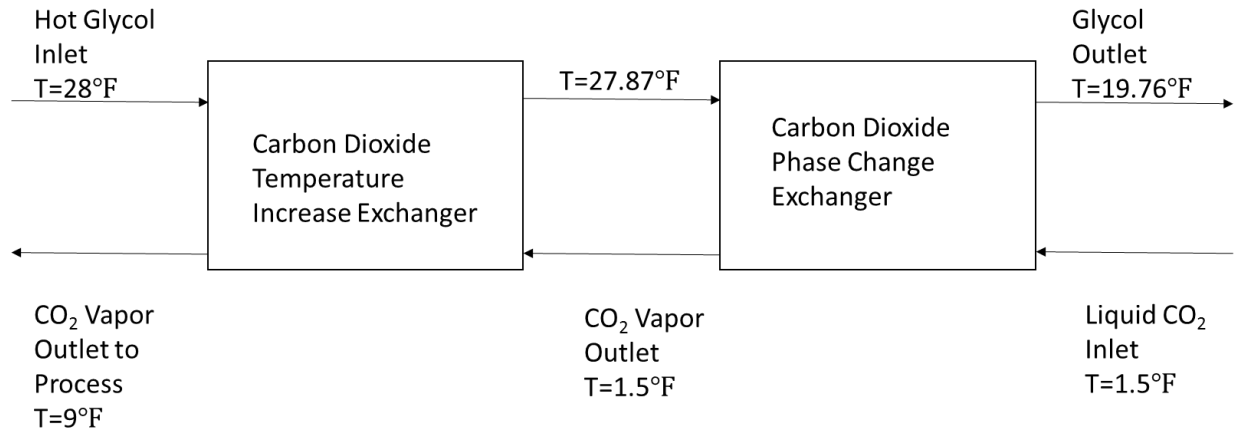

Figure 6: Pseudo Exchanger Diagram

With the temperatures of each inlet and outlet exchanger stream known, the logarithmic mean temperature differences were then calculated. The “phase change exchanger” ΔT_{LM} was 22.07°F , while the “temperature increase exchanger” ΔT_{LM} was 22.48°F . Due to the plan of using a multipass exchanger, a correction factor for each ΔT_{LM} needed to be considered and calculated. Upon calculation, however, both correction factors turned out to be 1, resulting in an unchanged ΔT_{LM} . The next step was to calculate the area of each exchanger and to unify the pseudo exchangers into one real exchanger. Using $Q = UA\Delta T_{LM}$ the areas of each exchanger were calculated and summed together. A nomograph was used to determine the overall heat transfer coefficients of both pseudo exchangers (See Figure E.2).¹¹ The “phase change exchanger” had an area of 51.76 sqft and the “temperature increase exchanger” had an area of 4.00 sqft resulting in a total area of 55.76 sqft. This area is known as the effective area because this is the required area for the actual exchanger to perform as designed. Exchangers require internal support structures in order for the physical manifestation of the design to be realized. To account for all internals, a factor of 10% was included in calculating the gross area of the exchanger. This resulted in a total required area of 61.34 sqft. Utilizing the gross area, the number of tubes required to achieve the heat transfer area was calculated. Using an assumed tube length of 4 ft and 1.25 inch triangular pitch with 1 inch outer diameter tubes, the number of tubes was determined to be 59. In order to determine the corresponding outer diameter of heat exchanger shell, the data from the tube sheet layout was plotted and an equation was fit to the data (Figure E.3). An 11.91 inch outer diameter was calculated using this formula. For ease of construction, this was rounded to a 12 inch diameter.

¹¹ Bowman, R. A., Mueller, A. E., and Nagle, W.M., Trans. ASME, vol. 62, p. 283 (1940).

Using a 12 inch diameter, the team calculated that the exchanger should have 66 tubes with 3.5 feet in length. All of these previously described calculations can be found in Appendix E. Additionally, the team has put together a heat exchanger data sheet (Appendix F) that combines several pertinent components to the heat exchanger including flow rates, temperatures, sizing etc. Figure 7 shows a sketch of the exchanger.

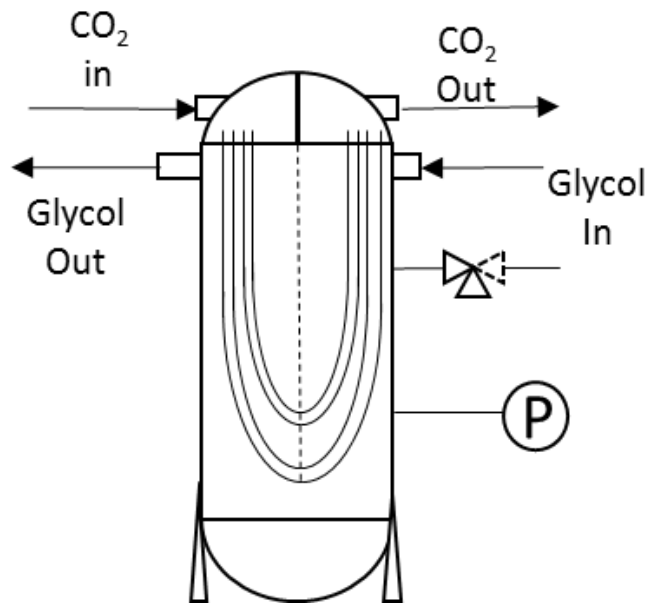

Figure 7: Sketch of completed heat exchanger

In addition, the heat exchanger will require a pressure relief valve which will burst at a shell side pressurization over 50 psig. This will prevent damage to the glycol coolant system should a tube in the heat exchanger fail. A pressure indicator is also required by the control system to exist on the shell side of the exchanger.

3.2.5 Site Plan

To maximize the effectiveness of the exchanger, it is necessary to consider its location at Wachusett Brewing Company. To ensure delivery of liquid CO₂ to the exchanger, it must be as close to the bulk carbon dioxide tank as possible. This will allow for minimal exposure to ambient temperature prior to the exchanger and will increase the refrigeration capabilities of the exchanger. The exchanger should also have some amount of protection about it, in the form of a short fence or guardrail. This fence would prevent forklift traffic from hitting the exchanger and possibly

knocking two systems out of commission. Ideally, the newly required glycol pumps should be installed as close to the existing pumps as possible.

3.2.6 HAZOP

In order to determine that the proposed systems were both operable and safe for general usage, the team completed a Hazard and Operability (HAZOP) study that focused on key equipment that are to be implemented (heat exchanger and pumps). The team used best engineering practices to determine which potential scenarios could cause a problem to the equipment and process and a risk analysis was performed for each entry. The Frequency of occurrence was ranked from 1 to 4, with 1 being infrequent and 4 being frequent. Likewise, the Impact of the described occurrence was ranked from 1 to 4, with 1 being insignificant and 4 being catastrophic. The Frequency value was then multiplied by the Impact value to achieve a Priority Number in order to help determine which systems needed a greater focus. The team then proposed actions or safeguards that could be put in place to minimize the associated risk. The Process Flow Diagram (Figure 5) was used as reference when completing this study. The HAZOP study can be seen in its entirety in Appendix G.

Process Heat Exchanger (HE-101)

One scenario that the team felt important to note was the case of an internal tube rupture within the heat exchanger, as the entire shell of the exchanger could become overpressurized and potentially damage the exchanger and glycol system. While this situation is unlikely to occur, the team feels that it would be a relatively cheap and simple effort to install a pressure relief valve on the shell side of the exchanger and set it to a lower pressure (50 psig). Additionally, emergency shutoff procedures have been implemented as seen in the Process Controls and Equipment section of this document in order to minimize damage to the glycol system and pumps in the event of a failure.

The team also determined that it is greatly important that the flow rates of propylene glycol and carbon dioxide are in the appropriate ratio with one another (21.25 lb glycol/lb CO₂). If the carbon dioxide flow rate is too high, the propylene glycol will become subcooled while the carbon dioxide

stream will not be completely vaporized. This can be a potential issue as subcooled glycol would flow throughout the facility to cool processes, and there is potential for diminishing quality of products if temperatures are too low. Non-vaporized carbon dioxide poses a concern as it can potentially freeze expansion valves and deteriorate products if it is subcooled or still in liquid form prior to use in the manufacturing process. Similarly, if the carbon dioxide flow rate is too low, the propylene glycol will not be cooled appropriately which could also jeopardize the quality of products. In order to easily and accurately ensure that the flow rates are in the proper ratio with one another, the team strongly recommends the implementation of a flow control valve and pressure gauges, as mentioned in the Process Controls and Equipment section below.

Pumps (P-8 and P-9)

Pumps P-8 and P-9 are responsible for pumping the propylene glycol to the proposed heat exchanger (HE-101). In the case of no propylene glycol flow to the heat exchanger, neither the propylene glycol nor the carbon dioxide experience any heat transfer, and as a result carbon dioxide is not vaporized and propylene glycol is not cooled. As the implications of this are similar to those mentioned above in the HE-101 section, it has been determined that a backup pump should be available for use at any time in the event of a pump failure or unexpected shut off. Both pumps P-8 and P-9 are designed to be variable speed in order to accommodate different flow rates and to maintain a proper ratio of flow rates with the carbon dioxide stream entering HE-101. While the proposed backup pump will activate itself whenever the original pump goes offline, it is still recommended that the manual valves on the carbon dioxide line are kept closed until the backup pump starts.

3.2.7 Process Controls

In response to some of the issues brought up in the HAZOP study, the team has determined that in order to effectively and safely construct the process described by the Process Flow Diagram (Figure 5), a variety of process controls and equipment needed to be implemented.

In order for the proposed heat exchanger to meet the demands of both the glycol coolant and process carbon dioxide loops, a process control system was designed, which can be seen in the Process Control Diagram below (Figure 8).

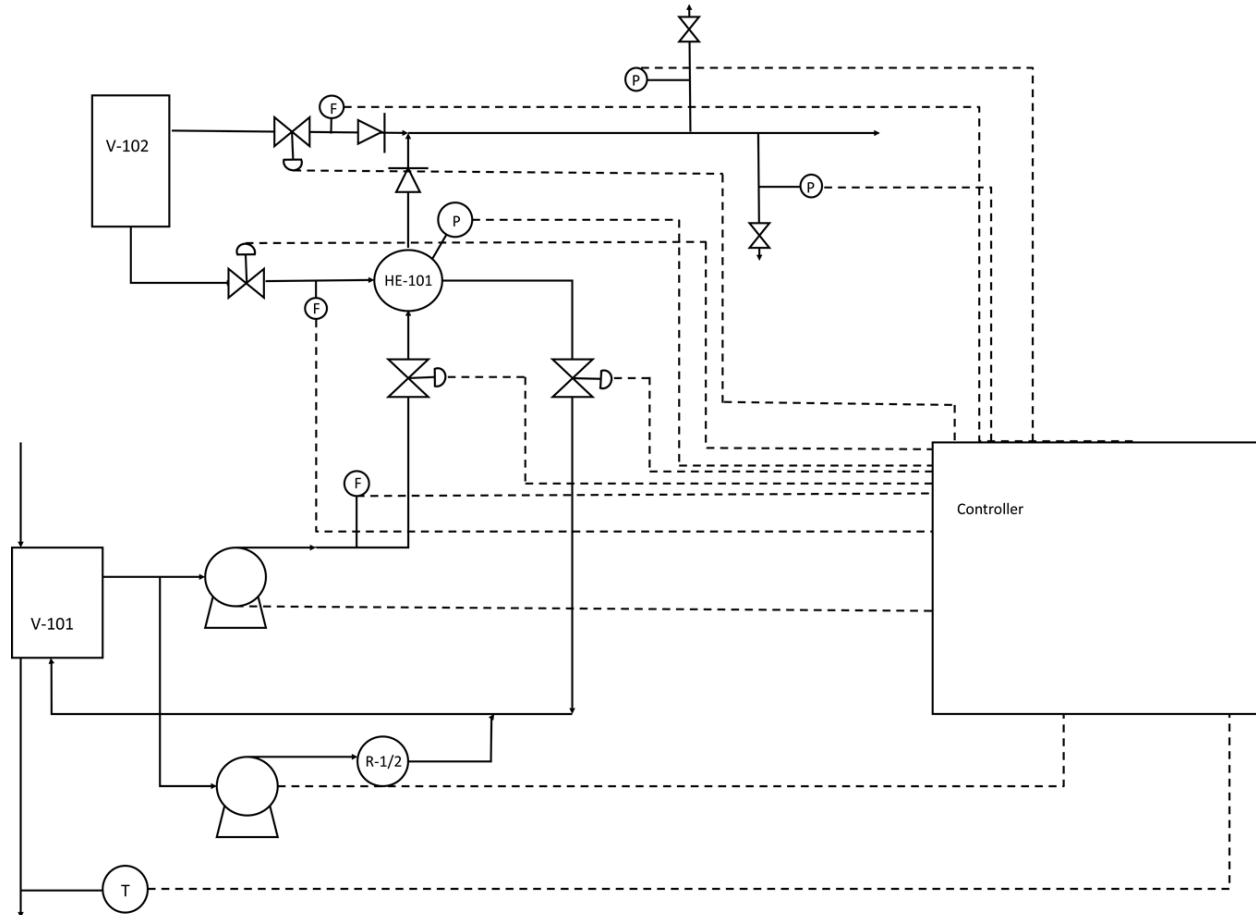

Figure 8: Process Control Diagram

First, the system has to detect whether or not there was a demand for carbon dioxide as well as if there is a need to chill the glycol. Checking for the need to chill the glycol merely calls for a thermocouple on the outlet of the glycol tank which goes to process. If the temperature is higher than the temperature setpoint, the glycol will require cooling; if not, there is no need to chill the glycol. Checking for carbon dioxide demand requires placing pressure indicators prior to every outlet valve. When a valve is opened, the pressure at the sensor will drop; the control system will interpret this and send a signal to the proper actuator to allow carbon dioxide flow. This flow will continue until the pressure setpoint is reached at every outlet valve, which can only occur when the valves are all shut. A programmable logic controller will take these inputs and decide what actuators need to be activated to meet both system requirements. If there is no need to chill the

glycol, yet a demand for carbon dioxide is detected, a valve on the vapor line out of the bulk storage tank will open. Should there be no need for carbon dioxide flow, yet the glycol needs to be chilled, glycol will be pumped to the existing refrigeration system.

If there is a need for both carbon dioxide flow and glycol chilling, the proposed exchanger system will be utilized. Once both needs are detected, the controller will indicate for the carbon dioxide liquid flow valve to open. This will allow liquid flow to pass to the exchanger. Before reaching the exchanger, however, its flow rate will be taken. This flow rate will then be used to scale the response of the glycol variable speed pump to have the glycol flow rate be in the right proportion to maximize heat exchange. The glycol will flow past a flow meter on its own line and the ratio of glycol to carbon dioxide flow will be measured and if it is not at the required 21.25 (found by taking the maximum flow of each species from the heat exchanger data sheet and dividing), the controller will indicate to the pump to increase or decrease glycol flow until this ratio is met. The flow meter on the carbon dioxide liquid line also serves a second purpose. The exchanger is only designed to handle 24 lb/min of CO₂, so if the flow meter detects a flow greater than this value it will have the liquid flow valve close until the flow is at its maximum value. The controller will also open the vapor line to ensure that the required carbon dioxide demand is met.

The control system will also include a few emergency systems built in to allow for continued plant operation should part of the proposed exchanger system fail. The first major emergency system is to detect a rupture in the carbon dioxide tubes in the exchanger and prevent this rupture from damaging the glycol system. There is a pressure indicator in the shell side of the exchanger and if the pressure in the shell side exceeds 50 psig, the sensor will relay this to the controller. The controller will then have the glycol pump shutdown and carbon dioxide flow valve close. In addition, flow valves on the glycol inlet and effluent lines will be automatically shut by the control system. A pressure relief valve will also burst on the exchanger at the specified 50 psig. To ensure carbon dioxide demands are still met, the vapor line will open when this emergency system is activated.

The second emergency system which was designed into the control scheme is for indicating pump failure. Should the glycol pump fail and the emergency system not be in place, there is a possibility

of liquid carbon dioxide being transported to processes downstream. The system also ensures that the heat exchanger is exchanging heat and reducing the refrigeration duty upon the existing glycol refrigeration system. To detect pump failure and ensure quick transfer to the backup pump, the flow meter after the pump will be utilized. Should no glycol flow be detected when there should be glycol flow, and a sufficient amount of time has passed, an alarm system will activate indicating that a pump has failed. The detection of no flow will also result in the carbon dioxide liquid flow valve being shut and the vapor valve opened to ensure that usage demands can be satisfied. Once the backup pump has been activated, the controller will be signaled that there is a functioning pump and the exchanger system can be reactivated.

3.2.8 Required Equipment and Modifications

Piping

The team determined the sizing of all piping and connections that are to be implemented under maximum flow scenario, where maximum pipe velocity is 10 ft/s to minimize pressure loss. In maximum flow scenario of 510 lb/min of glycol, it was determined that the glycol lines to and from the exchanger (Streams 7, 8, and 9) should consist of 2 inch schedule 10 piping. The team recommends schedule 10 piping for the glycol lines as the stream is not pressurized and excessive wall thickness is unnecessary. All pipes will require insulation ensuring the correct temperature and phase is maintained. As a good rule of thumb, 1.5 to 2 inches of insulation should be sufficient.¹² However, we are recommending 3 to 4 inches of insulation on the pipes to ensure that the carbon dioxide arrives at the exchanger in the liquid phase.

Currently, there is no liquid exit from the CO₂ tank so a new pipe will have to be installed in the bottom of the tank to allow liquid effluent. Similar to the glycol lines, maximum flow scenario was taken into consideration to determine necessary pipe sizes. The vaporized CO₂ line requires at least a 2 inch pipe while the liquid CO₂ line before the exchanger only requires a ½ inch pipe. However, the team recommends that Wachusett Brewing Company use 2 inch schedule 40 piping

¹² Perry, Robert H., Don W. Green, and James O. Maloney. *Perry's Chemical engineers' handbook*. New York: McGraw-Hill, 1984. Print.

for both before and after the heat exchanger (Streams 14 and 15) to be consistent with other pipe usage throughout the facility. It should be noted that the vapor line coming out of the top of the tank is currently the only exit line from the tank, so this line will be retained as a safety factor in the event that the newly installed lines fail or additional CO₂ is required. Full calculations for pipe sizing can be seen in Appendix H.

Valves

It is important that the system contains one-way valves before the vapor streams from the process heat exchanger and the CO₂ tank combine. There will likely be pressure differences between the two lines as a result of pressure drop through the exchanger and length of pipe, and as a result, backflow could occur if these gradients are too high. Including one-way valves will prevent any backflow from occurring due to these pressure gradients.

Selecting a Pump

For this system, only one set of pumps was needed. A pump after the CO₂ tank is unnecessary because the 300 psig tank will naturally allow liquid CO₂ to flow if a valve is opened at the bottom of the tank. The available head is enough to push the CO₂ through the pipes at the required flow rate. In addition, gravity aids the flow down through the valve because the weight of the liquid CO₂ itself will pressurize the CO₂ on the bottom of the tank and induce flow.

Using the maximum flow rate of 510 lb/min for the glycol mixture, as well as the pressure boost of 5 psi required, the calculated shaft power for the pump was 0.3278 kW (Appendix I). This is a very small amount of power for a centrifugal pump, which is likely due to the small pressure boost required. Even if Wachusett Brewing Company wanted a slightly larger pump to ensure that it would have enough power to accommodate all pumping scenarios, the pump would still be smaller than the pumps currently in use for the glycol system. Any pump larger than the 0.3278 kW would be able to handle the flow rates and pressures that this system will require. Two identical pumps should be installed for this system: one main pump and one backup pump. If the main pump stops working for any reason, the flow can be redirected by opening lines to the backup pump. This ensures that a pump malfunction will not delay the process significantly.

Wachusett Brewing Company will likely need to purchase a pump of higher capacity than suggested due to the difficulty of finding low capacity pumps with high flow rates. For convenience, the company could purchase two additional pumps of the same size and power as the ones already in use. This way, all the pumps would be able to perform the same task and if one breaks then it could be easily replaced with another one. Purchasing pumps of this size also ensures that they will be able to handle any reasonable glycol flow rate. However, the cost analysis only takes into account two pumps (one main and one backup pump) that have a 0.3278 kW capacity each. If Wachusett Brewing Company wanted to use larger pumps, these would be more expensive, thus increasing the capital cost and the payback period.

3.3 Economic Feasibility

In this section we determine the capital cost of all equipment. We utilized the Lang factor method, which multiplies the total capital cost of the unit by a factor to cover all costs related to construction and installation, to determine the overall cost of the unit. We then determine the cost of currently refrigerating glycol and the savings of installing the proposed system.

3.3.1 Determining Cost of Equipment

The program CAPCOST was used to approximate the cost of constructing the proposed heat exchanger and pumps. The inputs to the CAPCOST program included the type of exchanger, area of the exchanger, material of construction, and maximum operating pressures on the tube side and shell side (Appendix J). The proposed exchanger was smaller than the smallest exchanger size allowable in CAPCOST. Thus, the cost of the proposed exchanger had to be extrapolated through the use of a simple equation seen in Appendix K. After the cost of our actual exchanger was calculated, the cost of the pumps was determined in the same manner where inputs can be seen in Appendix J and the cost can be seen in Appendix L.

After calculating the installation and capital cost of the heat exchanger and pumps, the payback period was calculated, as well as the amount of savings after the initial investment was earned back. This analysis allowed the team to provide recommendations to Wachusett Brewing Company regarding the economic feasibility of the exchanger.

3.3.2 Determining Total Savings

After determining the capital cost and using the Lang factor method to approximate the overall project cost, the team looked into how much money the construction of this exchanger would save Wachusett Brewing Company over the life of this exchanger. The first step was to calculate the efficiency of the existing glycol chiller (Appendix M). Once we had this efficiency we could know how much energy was required to chill a pound of glycol. We then determined the cost per pound of glycol cooled by the existing refrigeration unit. To do this, we used the specific heat formula from earlier to determine how much energy was required to cool one pound of the propylene

glycol-water mixture by 8°F, the assumed refrigeration load of our exchanger. We then divided this number, in BTU, by the efficiency of the refrigeration unit since this unit would not cool the glycol with 100% efficiency. We then converted this energy to kWh and multiplied by the electric rate Wachusett Brewing Company pays. This resulted in a cost of \$0.000599/lb glycol cooled (Appendix N). We then determined the savings over the lifetime of the heat exchanger. This required a few assumptions:

1. Whenever CO₂ is required, glycol also needed to be cooled
2. The average carbon dioxide flow rate is a good estimate to use when determining the amount of glycol cooled per minute
3. Carbon dioxide is used 8 hours per day, 5 days per week, 52 weeks per year
4. The lifetime of the exchanger is ten years
5. The time value of money was not taken into consideration due to the perceived instabilities in the market over the next few years
6. The electricity rate will be the same over the ten year interval

With these assumptions in mind, we determined that the exchanger should save Wachusett Brewing Company \$191,000 in energy costs over the course of its lifetime. The total savings, after the \$58,300 capital investment is \$132,700. The initial investment will be earned back after 3.1 years. This is indicative of the investment being economically feasible, though it may not be the most favorable, especially with the assumptions made. When the time value of money is taken into consideration, the net present value of these savings will diminish. In addition, the total savings will decrease when one considers that the glycol may not always need to be cooled when there is a demand for carbon dioxide.

4.0 Conclusions and Recommendations

We have determined that it is entirely feasible to utilize the bulk carbon dioxide storage tank as a source for coolant for the glycol system. The carbon dioxide is able to chill a large quantity of glycol from its process return temperature to the required tank return temperature, while expanding into a vapor. The control system we designed will be able to meet both glycol and carbon dioxide system demands as well as unite the two areas of the process.

Based on our economic analysis, we believe it is economically feasible that Wachusett Brewing Company construct this heat exchanger as it has been designed. The heat exchanger is small, inexpensive, and only requires a small amount of additional equipment to function properly. There would be minimal loss of time when installing this heat exchanger because the glycol and CO₂ systems can continue running normally while the exchanger and pumps are being installed. The only installation process that interferes with the brewery's current system is the addition of connecting pipes to the glycol loop and the bottom of the CO₂ tank.

As mentioned above, our analysis is contingent upon the following assumptions:

- Whenever CO₂ is required, glycol also needed to be cooled
- The average carbon dioxide flow rate is a good estimate to use when determining the amount of glycol cooled per minute
- Carbon dioxide is used 8 hours per day, 5 days per week, 52 weeks per year
- The lifetime of the exchanger is ten years
- The time value of money was not taken into consideration due to the perceived instabilities in the market over the next few years
- The electricity rate will be the same over the ten year interval

It is unlikely that all of these assumptions are entirely valid. Thus, there is a risk that the initial capital investment may not be recovered by the Wachusett Brewing Company. That being said, some assumptions may also positively impact the feasibility of implementing this exchanger. For example, if Wachusett Brewing Company's current electricity rate increases at any point during the life of the exchanger, then the total savings will increase. Taking all of this into account, we recommend considering construction of the proposed process heat exchanger by the Wachusett Brewing Company.

References

- Bowman, R. A., Mueller, A. E., and Nagle, W.M., Trans. ASME, vol. 62, p. 283 (1940).
- "Converting Pump Head to Pressure and Vice Versa." Converting Pump Head to Pressure and Vice Versa. The Engineering Toolbox, n.d. Web. 12 Feb. 2017.
http://www.engineeringtoolbox.com/pump-head-pressure-d_663.html
- "Cooling Load - Convert kW/ton to COP or EER." Cooling Load - Convert kW/ton to COP or EER. The Engineering Toolbox, n.d. Web. 25 Mar. 2017.
http://www.engineeringtoolbox.com/cop-eer-d_409.html
- "Ethylene vs Propylene Glycol." Ethylene vs Propylene Glycol | Heat Transfer Fluids | The Dow Chem. The DOW Chemical Company, n.d. Web. 07 Feb. 2017.
<http://www.dow.com/heattrans/support/selection/ethylene-vs-propylene.htm>
- Hadidi, Amin, and Ali Nazari. Diagram of a typical shell and tube heat exchanger. Digital image. ResearchGate. ResearchGate, Jan. 2013. Web. 28 Feb. 2017.
https://www.researchgate.net/figure/233997584_fig1_Fig-1-Diagram-of-a-typical-shell-and-tube-heat-exchanger-12
- "Heat Exchanger Type Selection." Heat Exchanger Type Selection. H&C Heat Transfer Solutions, n.d. Web. 07 Feb. 2017. <http://www.hcheattransfer.com/selection.html>
- Jenkins, Scott. "Economic Indicators: CEPCI - Chemical Engineering." Chemical Engineering Economic Indicators CEPCI Comments. N.p., 19 Mar. 2015. Web. 15 Feb. 2017.
<http://www.chemengonline.com/economic-indicators-cepci/?printmode=1>
- "Kilowatts to Tons (Refrigeration) Conversion Calculator." *Kilowatts to Tons (Refrigeration) Conversion Calculator*. N.p., n.d. Web. 06 Feb. 2017.
<http://www.unitconversion.org/power/kilowatts-to-tons-refrigeration-conversion.html>
- "Maximum Flow Velocities in Water Systems." The Engineering ToolBox. N.p., n.d. Web. 05 Apr. 2017. http://www.engineeringtoolbox.com/flow-velocity-water-pipes-d_385.html
- "Metals4u Online - Dallas Warehouse." Quality Metals Cheaper Online Source Aluminum Steel Stainless. Metals4uOnline, 2016. Web. 25 Mar. 2017.
<https://www.metals4uonline.com/PipeSchedule10,40,80Specifications>

Perry, Robert H., Don W. Green, and James O. Maloney. *Perry's Chemical engineers' handbook*. New York: McGraw-Hill, 1984. Print.

"Saturation Table CO₂." Tega Refrigerants and Specialties, n.d. Web. 6 Feb. 2017. http://www.linde-gas.ro/internet.lg.lg.rou/ro/images/R74454_138675.pdf?v=2.0

Sloley, Andrew. "Shell-and-Tube Heat Exchanger: Pick the Right Side." *Chemical Processing*. N.p., 23 Oct. 2013. Web. 07 Feb. 2017. <http://www.chemicalprocessing.com/articles/2013/shell-and-tube-heat-exchanger-best-practices/>

Stephanopoulos, George. *Chemical Process Control An Introduction to Theory and Practice*. New Jersey: Prentice Hall, 1984. Print.

"Summary." Pump Power Calculation – Neutrium. Native Dynamics, n.d. Web. 12 Feb. 2017. <https://neutrium.net/equipment/pump-power-calculation/>

"TEMA Designations of Heat Exchangers." Wermac, n.d. Web. 28 Feb. 2017. <http://www.thermaltransfersystems.com/pdf/TEMA%20DESIGNATIONS%20OF%20HEAT%20EXCHANGERS.pdf>

Turton, Richard, et al. (2003) *Analysis, Synthesis, and Design of Chemical Processes*, Upper Saddle River, NJ: Prentice Hall

VanderGiessen, Jim, Jr. "ProBrewer.com." ProBrewercom. Pro Refrigeration Inc., n.d. Web. 07 Feb. 2017. <http://www.probrewer.com/library/refrigeration/everything-you-wanted-to-know-about-glycol/>

Wischnewski, Berndt. "Online - Calculation - Carbon dioxide." *Online - Calculation - Carbon dioxide*. N.p., n.d. Web. 06 Feb. 2017. http://www.peacesoftware.de/einigewerte/co2_e.html

Appendices

A. Carbon Dioxide System

A.1 Calculation of Average Carbon Dioxide Usage

$$\dot{m}_{CO_2} = m_{CO_2} / t_{operating}$$

$$m_{CO_2} = 348,050 \text{ lb (August 1}^{st} \text{ to October 25}^{th} \text{ (See A.2))}$$

$$t_{operating} = 60 \text{ days} * 8 \frac{\text{hours}}{\text{day}} * 60 \frac{\text{minutes}}{\text{hour}} = 28,800 \text{ minutes}$$

$$\dot{m}_{CO_2} = \frac{348,050 \text{ lb}}{28,800 \text{ minutes}} = 12 \text{ lb/min}$$

Table A.1 Wachusett Brewing Company Carbon Dioxide Delivery Record for August through October 2016

<u>Bulk liquid CO2 received (in lbs.)</u>	
<u>DATE RECEIVED</u>	<u>VOLUME</u>
1-Aug	16,420
3-Aug	14,380
8-Aug	19,150
10-Aug	10,400
15-Aug	15,000
17-Aug	10,500
23-Aug	16,300
22-Aug	18,100
29-Aug	11,400
30-Aug	19,300
<u>AUGUST TOTAL</u>	150,950

<u>DATE RECEIVED</u>	<u>VOLUME</u>
1-Sep	11,400
6-Sep	21,500
8-Sep	12,900
12-Sep	13,900
14-Sep	9,500
19-Sep	20,400
21-Sep	17,500
26-Sep	13,000
28-Sep	12,800
<u>SEPTEMBER TOTAL</u>	132,900
3-Oct	12,900
5-Oct	11,100
10-Oct	13,200
13-Oct	7,600
18-Oct	12,700
19-Oct	6,700
25-Oct	11,900
<u>OCTOBER TOTAL</u>	76,100
<u>TOTAL</u>	<u>359,950</u>
<u>Total Consumed 1-Aug to 25-Oct</u>	348,050

A.2 Determining Temperature of Saturated Liquid CO₂

From saturation table¹³ of CO₂

$$X_0 = 2223.70 \text{ kPa}$$

$$Y_0 = -16 \text{ C}$$

$$X_1 = 2158.10 \text{ kPa}$$

$$Y_1 = -17 \text{ C}$$

$$X = 300 \text{ psig} = 314 \text{ psia} = 2164.95 \text{ kPa}$$

Use linear interpolation to determine the temperature of the saturated CO₂, Y.

$$Y = Y_0 + (X - X_0) * \frac{Y_1 - Y_0}{X_1 - X_0}$$

$$Y = -16^\circ\text{C} + (2164.95\text{kPa} - 2223.70\text{kPa}) * \frac{-17^\circ\text{C} - (-16^\circ\text{C})}{2158.10\text{kPa} - 2223.70\text{kPa}}$$

$$Y = -16.9^\circ\text{C} = 1.58^\circ\text{F}$$

We ultimately assumed the temperature of CO₂ leaving the tank to be 1.5°F to be consistent with Aspen Simulations.

A.3 Carbon Dioxide Properties:

Used Peace Software¹⁴ to calculate the density of the liquid CO₂, and dynamic viscosity. Input liquid CO₂ at 314 psia (300 psig) and -16.94°C (1.5°F).

$$\rho_{liquid} = 63 \frac{lb}{ft^3}$$

$$\rho_{vapor} = 3.36 \frac{lb}{ft^3}$$

¹³ "Saturation Table CO₂." Tega Refrigerants and Specialties, n.d. Web. 6 Feb. 2017.

¹⁴ Wischnewski, Berndt. "Online - Calculation - Carbon dioxide." *Online - Calculation - Carbon dioxide*. N.p., n.d. Web. 06 Feb. 2017.

B. Propylene Glycol System

Determining maximum flow rate for current propylene glycol system based on heat duties

$$\dot{Q} = \dot{m}c_p \Delta T$$

$$\dot{Q} = \dot{Q}_r + \dot{Q}_t$$

1 ton of refrigeration \approx 3.5 kilowatts (from Engineering Toolbox)¹⁵

$$\dot{Q}_r = 40 \text{ ton} * \frac{3.5 \text{ kW}}{1 \text{ ton}} = 140 \text{ kW}$$

$$\dot{Q}_t = 50 \text{ ton} * \frac{3.5 \text{ kW}}{1 \text{ ton}} = 175 \text{ kW}$$

$$\dot{Q} = 140 \text{ kW} + 175 \text{ kW} = 315 \text{ kW} = 1,074,824.73 \frac{\text{Btu}}{\text{hr}}$$

$$c_p = 0.70 \frac{\text{Btu}}{\text{lb}_m \text{ } ^\circ\text{F}}$$

$$T_{out} = 20^\circ\text{F}$$

$$T_{in} = 28^\circ\text{F}$$

Rearrange top equation

$$\dot{m} = \frac{c_p \Delta T}{\dot{Q}} = 191,933 \frac{\text{lb}_m}{\text{hr}} = 3,199 \frac{\text{lb}_m}{\text{min}}$$

Determining maximum flow rate for glycol tank based on current pipe sizing

Using 2 inch schedule 10 piping

$$\rho_{liquid \text{ glycol}} = 63.4 \frac{\text{lb}}{\text{ft}^3}$$

$$D_{inner} = 2.157 \text{ in}^{16}$$

$$v_{max} = 10 \frac{\text{ft}}{\text{s}}$$

$$A_c = \frac{\pi D_{inner}^2}{4} = 3.66 \text{ in}^2 = 0.0254 \text{ ft}^2$$

$$\dot{V} = A_c * v_{max} = 0.0254 \text{ ft}^2 * 10 \frac{\text{ft}}{\text{s}} = 0.254 \frac{\text{ft}^3}{\text{s}}$$

$$\dot{m} = \dot{V} * \rho_{liquid \text{ glycol}} = 0.254 \frac{\text{ft}^3}{\text{s}} * 63.4 \frac{\text{lb}}{\text{ft}^3} = 15.22 \frac{\text{lb}}{\text{s}} * 60 \frac{\text{s}}{\text{min}} = 965 \frac{\text{lb}}{\text{min}}$$

¹⁵ "Kilowatts to Tons (Refrigeration) Conversion Calculator." *Kilowatts to Tons (Refrigeration) Conversion Calculator*. N.p., n.d. Web. 06 Feb. 2017.

¹⁶ "Metals4u Online - Dallas Warehouse." Quality Metals Cheaper Online Source Aluminum Steel Stainless. Metals4uOnline, 2016. Web. 25 Mar. 2017.

C. Process Flow Diagram Table of Stream Data

Table C.1: Process Flow Diagram Table of Stream Data

Stream	1	2	3	4	5	6	7	8	9
Description	Feed 1 to Glycol Tank	Feed 2 to Glycol Tank	Combined Feed to Glycol Tank	Uncooled Glycol leaving Glycol Tank	Glycol Feed to Current Refrigeration System	Glycol Leaving Current Refrigeration System	Glycol Feed to Proposed Heat Exchanger	Pressurize Glycol Feed to Proposed Heat Exchanger	Cooled Glycol leaving Proposed Heat Exchanger
Total Flow (lb/min)	Blank	Blank	Blank	1475	965	965	510	510	510
Temperature (F)	30	30	30	28	28	20	28	28	20
Pressure (psig)	Below 25	Below 25	Below 25	Below 25	Below 25	Below 25, higher than stream 5	Below 25	25	Below 25, higher than stream 7

Stream	10	11	12	13	14	15	16	17
Description	Cooled Glycol Returning to Glycol Tank	Cooled Glycol leaving Glycol Tank	Cooled Glycol to Process	Cooled Glycol to Process	Liquid CO2 Leaving CO2 Tank	Vapor CO2 Leaving Proposed Heat Exchanger	Vapor CO2 Leaving CO2 Tank	Vapor CO2 to Process
Total Flow (lb/min)	1475	Blank	Blank	Blank	24	24	Blank	24
Temperature (F)	20	24	24	24	2	10	Blank	Blank
Pressure (psig)	Below 25, higher than stream 5	Below 25	25	25	300	295	300	295

D. Aspen Input File

```
;  
;Input Summary created by Aspen Plus Rel. 34.0 at 16:30:02 Wed Feb 22, 2017  
;Directory R:\MQP Filename R:\MQP\property data.inp  
;  
  
DYNAMICS  
DYNAMICS RESULTS=ON  
  
IN-UNITS MET PRESSURE=bar TEMPERATURE=C DELTA-T=C PDROP=bar &  
  INVERSE-PRES='1/bar'  
  
DEF-STREAMS CONVEN ALL  
  
MODEL-OPTION  
  
DATABANKS 'APV88 PURE32' / 'APV88 AQUEOUS' / 'APV88 SOLIDS' / &  
  'APV88 INORGANIC' / 'APEOSV88 AP-EOS' / NOASPENPCD  
  
PROP-SOURCES 'APV88 PURE32' / 'APV88 AQUEOUS' / 'APV88 SOLIDS' &  
  / 'APV88 INORGANIC' / 'APEOSV88 AP-EOS'  
  
COMPONENTS  
CARBO-01 CO2 /  
WATER H2O /  
PG-ET-01 C7H14O3-D1  
  
SOLVE  
RUN-MODE MODE=SIM  
  
FLOWSHEET  
BLOCK B1 IN=3 1 OUT=4 2  
  
PROPERTIES UNIFAC  
  
PROP-SET PS-1 CP UNITS='Btu/lb-F' SUBSTREAM=MIXED COMPS=WATER &  
  PG-ET-01 PHASE=L  
  
PROP-SET PS-2 CP UNITS='Btu/lb-F' SUBSTREAM=MIXED &  
  COMPS=CARBO-01 PHASE=V
```

PROP-SET PS-3 DHVL UNITS='Btu/lb' SUBSTREAM=MIXED &
COMPS=CARBO-01 PHASE=L

STREAM 1

SUBSTREAM MIXED TEMP=1.5 <F> PRES=300. <psig>
MASS-FLOW CARBO-01 24. <lb/min>

STREAM 3

SUBSTREAM MIXED TEMP=28. <F> PRES=25. <psig>
MASS-FLOW WATER 255. <lb/min> / PG-ET-01 255. <lb/min>

BLOCK B1 HEATX

PARAM T-COLD=9. <F> CALC-TYPE=DESIGN U-OPTION=PHASE &
F-OPTION=CONSTANT CALC-METHOD=SHORTCUT
FEEDS HOT=3 COLD=1
OUTLETS-HOT 4
OUTLETS-COLD 2
HOT-SIDE DP-OPTION=CONSTANT DPPARMOPT=NO
COLD-SIDE DP-OPTION=CONSTANT DPPARMOPT=NO
TQ-PARAM CURVE=YES

EO-CONV-OPTI

STREAM-REPOR MOLEFLOW

PROP-TABLE PURE-1 PROPS

IN-UNITS MET PRESSURE=psig TEMPERATURE=F DELTA-T=C PDROP=bar &
INVERSE-PRES='1/bar'
MOLE-FLOW WATER 1 / PG-ET-01 1
PROPERTIES UNIFAC FREE-WATER=STEAM-TA SOLU-WATER=3 &
TRUE-COMPS=YES
VARY TEMP
RANGE LOWER=0 UPPER=100.0000000 NPOINT= 50
VARY PRES
RANGE LIST=20.
PARAM
TABULATE PROPERTIES=PS-1

PROP-TABLE PURE-2 PROPS

IN-UNITS MET PRESSURE=psig TEMPERATURE=F DELTA-T=C PDROP=bar &

INVERSE-PRES='1/bar'
MOLE-FLOW CARBO-01 1
PROPERTIES UNIFAC FREE-WATER=STEAM-TA SOLU-WATER=3 &
TRUE-COMPS=YES
VARY TEMP
RANGE LOWER=0 UPPER=100.0000000 NPOINT= 50
VARY PRES
RANGE LIST=300.
PARAM
TABULATE PROPERTIES=PS-2

PROP-TABLE PURE-3 PROPS
IN-UNITS MET PRESSURE=psig TEMPERATURE=F DELTA-T=C PDROP=bar &
INVERSE-PRES='1/bar'
MOLE-FLOW CARBO-01 1
PROPERTIES UNIFAC FREE-WATER=STEAM-TA SOLU-WATER=3 &
TRUE-COMPS=YES
VARY TEMP
RANGE LOWER=0 UPPER=100.0000000 NPOINT= 50
VARY PRES
RANGE LIST=300.
PARAM
TABULATE PROPERTIES=PS-3

;
;
;
;
;
;

E. Calculating Area of Heat Exchanger

Due to the phase change and the temperature rise of the carbon dioxide we had to approximate the exchanger as two units for design purposes, then unite them into an exchanger with the summed area of the two pseudo exchangers.

E.1 Calculation of ΔT_{LM}

Solving for heat duty of carbon dioxide side of exchanger

$$\dot{Q} = \dot{Q}_1 + \dot{Q}_2$$

$$\dot{Q}_1 = \dot{m}_{CO_2} \lambda$$

$$\dot{Q}_2 = \dot{m} c_p \Delta T$$

From our Aspen Plus simulations, we acquired the following values:

$$c_p(\text{liquid}) = \frac{0.69 \text{ Btu}}{\text{lb}^\circ\text{F}}$$

$$c_p(\text{vapor}) = \frac{0.25 \text{ Btu}}{\text{lb}^\circ\text{F}}$$

$$\lambda = 119 \frac{\text{Btu}}{\text{lb}}$$

$$T_0 = 1.5^\circ\text{F}$$

$$T_1 = 9^\circ\text{F}$$

$$\dot{Q}_1 = 1440 \frac{\text{lb}}{\text{hr}} * 119 \frac{\text{Btu}}{\text{lb}} = 171,360 \frac{\text{Btu}}{\text{hr}}$$

$$\dot{Q}_2 = 1440 \frac{\text{lb}}{\text{hr}} * \frac{0.25 \text{ Btu}}{\text{lb}^\circ\text{F}} * (9^\circ\text{F} - 1.5^\circ\text{F}) = 2,700 \frac{\text{Btu}}{\text{hr}}$$

$$\dot{Q} = 171,360 \frac{\text{Btu}}{\text{hr}} + 2,700 \frac{\text{Btu}}{\text{hr}} = 174,060 \frac{\text{Btu}}{\text{hr}}$$

Solving for outlet glycol temperature

$$\dot{Q} = \dot{m} c_p \Delta T$$

$$174,060 \frac{\text{Btu}}{\text{hr}} = 1440 \frac{\text{lb}}{\text{hr}} * 0.70 \frac{\text{Btu}}{\text{lb}_m^\circ\text{F}} * (28^\circ\text{F} - T)$$

$$T = 19.76^\circ\text{F}$$

Now solve for the temperature of the glycol stream entering the “CO₂ phase change exchanger”

$$\dot{Q}_1 = 171,360 \frac{\text{Btu}}{\text{hr}} = 1440 \frac{\text{lb}}{\text{hr}} * 0.70 \frac{\text{Btu}}{\text{lb}_m^\circ\text{F}} * (T - 19.76^\circ\text{F})$$

$$T = 27.87^\circ\text{F}$$

Now need to obtain the ΔT_{LM} of each exchanger

$$\Delta T_{LM} = \frac{(T_{Glycol\ out} - T_{CO_2\ in}) - (T_{Glycol\ in} - T_{CO_2\ out})}{\ln \left[\frac{(T_{Glycol\ out} - T_{CO_2\ in})}{(T_{Glycol\ in} - T_{CO_2\ out})} \right]}$$

ΔT_{LM1} (“CO₂ phase change exchanger”)

$$\Delta T_{LM1} = \frac{(19.76^\circ\text{F} - 1.5^\circ\text{F}) - (27.87^\circ\text{F} - 1.5^\circ\text{F})}{\ln \left[\frac{(19.76^\circ\text{F} - 1.5^\circ\text{F})}{(27.87^\circ\text{F} - 1.5^\circ\text{F})} \right]} = 22.07^\circ\text{F}$$

ΔT_{LM2} (“CO₂ temperature change exchanger”)

$$\Delta T_{LM2} = \frac{(27.87^\circ\text{F} - 1.5^\circ\text{F}) - (28^\circ\text{F} - 9^\circ\text{F})}{\ln \left[\frac{(27.87^\circ\text{F} - 1.5^\circ\text{F})}{(28^\circ\text{F} - 9^\circ\text{F})} \right]} = 22.48^\circ\text{F}$$

E.2 Correction Factor for Multiple Pass Exchangers

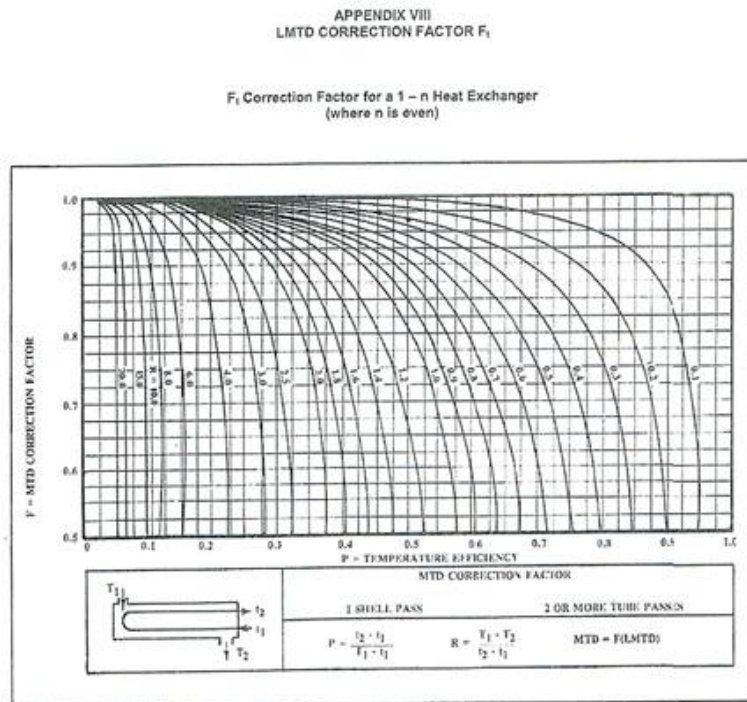

Figure E.1: ΔT_{LM} Correction Factor¹⁷

“CO₂ phase change exchanger” ΔT_{LM1} correction F

$F = 1$ because

$$P = 0 = \frac{(1.5 - 1.5)}{(27.87 - 1.5)}$$

$$R = \text{Infinity} = \frac{(27.87 - 19.76)}{(1.5 - 1.5)}$$

¹⁷ Bowman, R. A., Mueller, A. E., and Nagle, W.M., Trans. ASME, vol. 62, p. 283 (1940).

“CO₂ temperature change exchanger” ΔT_{LM2} correction F

$F = 1$ because

$$P = 0.28 = \frac{(9 - 1.5)}{(28 - 27.87)}$$

$$R = 0.02 = \frac{(28 - 27.87)}{(9 - 1.5)}$$

E.3 Calculation of Heat Transfer Coefficient:

To determine a heat transfer coefficient for the proposed heat exchanger, a nomograph was used. CO₂ was considered to be a refrigerant and glycol a dilute aqueous. Connecting these two respective areas of the nomograph below gave an approximate overall heat transfer coefficient of $50 \frac{Btu}{h \cdot ft^2 \cdot ^\circ F}$. When considering carbon dioxide as a vapor; the overall heat transfer coefficient was measured to be $30 \frac{Btu}{h \cdot ft^2 \cdot ^\circ F}$.

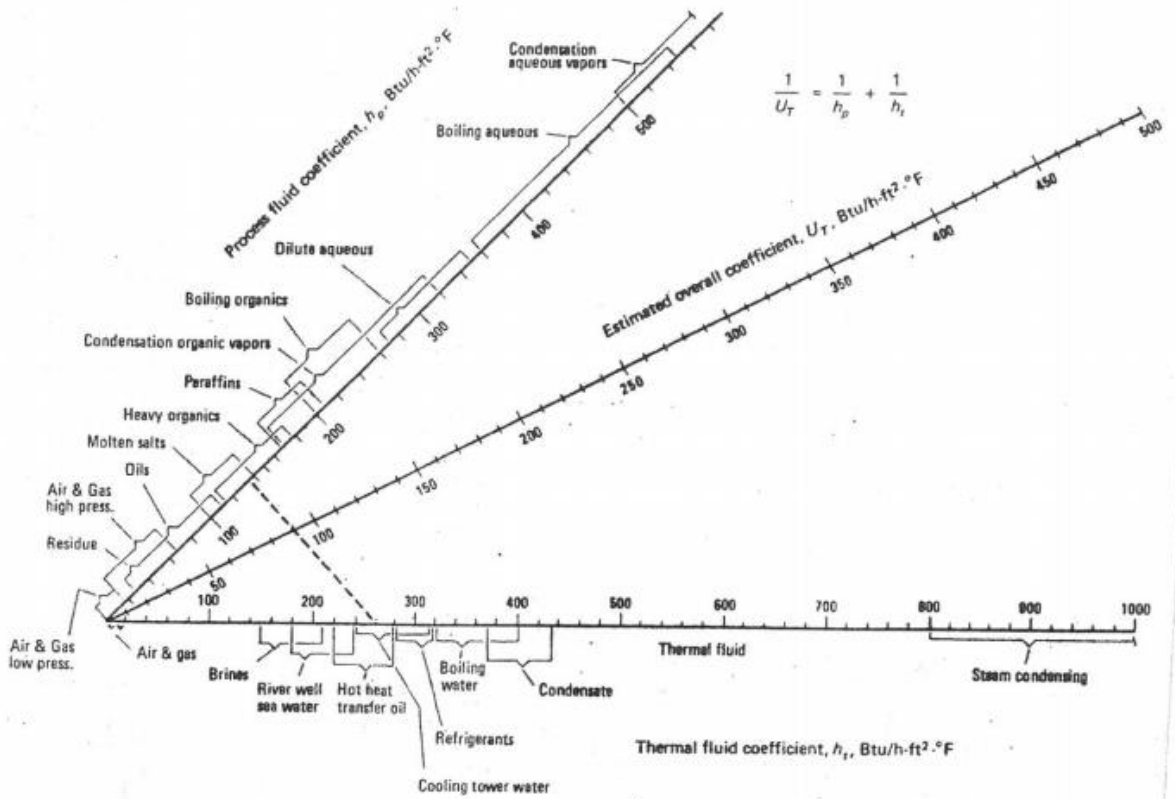

Figure E.2: Nomograph used for determining overall heat transfer coefficients¹⁸

¹⁸ Bowman, R. A., Mueller, A. E., and Nagle, W.M., Trans. ASME, vol. 62, p. 283 (1940).

E.4 Calculation of Areas Required

Can now calculate areas of both exchangers

$$\dot{Q} = UAF\Delta T_{LM}$$

$$A = \frac{\dot{Q}}{UF\Delta T_{LM}}$$

A_1 (Area of “CO₂ phase change exchanger”)

$$A_1 = \frac{171,360 \frac{Btu}{hr}}{1 * 22.07^\circ F * 150 \frac{Btu}{h * ft^2 * ^\circ F}} = 51.76 ft^2$$

A_2 (Area of “CO₂ temperature change exchanger”)

$$A_1 = \frac{2,700 \frac{Btu}{hr}}{1 * 22.48^\circ F * 30 \frac{Btu}{h * ft^2 * ^\circ F}} = 4.00 ft^2$$

$$A_{Effective} = A_1 + A_2$$

$$A_{Effective} = 51.76 ft^2 + 4.00 ft^2 = 55.76 ft^2$$

$$A_{Gross} = 1.1 * A_{Effective}$$

$$A_{Gross} = 1.1 * 55.76 ft^2 = 61.34 ft^2$$

E.5 Determining Number of Tubes Required

Chose a 1.25 inch triangular pitch with 1 inch diameter pipes for the exchanger

Assumed length of 4 ft for the tubes

$$SA_{Tube} = \pi D l$$

$$SA_{Tube} = \pi * \frac{1}{12} ft * 4 ft = 1.05 ft^2$$

$$Tubes\ required = A_{Gross} / SA_{Tube}$$

$$Tubes\ required = 61.34 \frac{ft^2}{1.05 ft^2} = 59\ tubes$$

Since the exchanger is a double pass exchanger we utilized the two pass column from the following tube sheet layout chart.

1" O.D. Tubes on 1 1/4" Triangular Pitch V

Shell Size	Fixed Tube Sheet			Outside Jacket Floating Head			Inside Floating Head		
	1-P	2-P	4-P	1-P	2-P	4-P	1-P	2-P	4-P
5"	8	6	4	7	6	4	7	6	4
6"	13	14	12	10	10	8	10	10	8
8"	31	26	24	22	22	16	22	20	16
10"	42	44	36	38	40	36	38	36	28
12"	64	66	56	61	52	48	56	52	48
14"	85	82	72	70	68	64	74	72	68
16"	110	110	100	96	94	80	100	98	92
18"	131	146	136	130	124	116	130	132	120
20"	167	180	172	163	150	144	170	160	160
22"	230	228	212	202	192	180	212	200	196
24"	266	270	252	238	232	212	238	236	232
28"	380	368	352	336	334	308	346	346	324
32"	506	494	480	450	448	432	472	468	440
36"	646	642	624	596	582	572	618	610	584

*1-P is 1 Pass, 2-P is 2 Pass, 4-P is 4 Pass.

Table E.1: Tube Sheet Layouts¹⁹

Using data sheet, the graph below was generated to calculate OD of shell

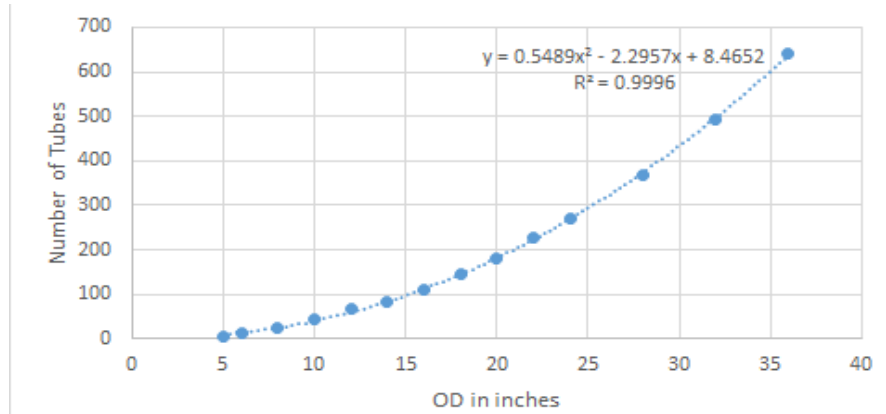

Figure E.3: Correlation between number of tubes and shell outer diameter

Using the 59 tubes with the equation above, the outer diameter was determined to be 11.91 inches. It makes sense to round to 12 inches for manufacturing purposes.

Re-solving using a 12 inch outer diameter tubes yielded 66 actual tubes. The following formula used the required gross area and the diameter to determine the length of tubes required.

$$L = \frac{61.34 \text{ ft}^2}{66 \text{ tubes} * \frac{1}{12} \text{ ft/tube}} = 3.55 \text{ ft}$$

After rounding to the nearest half foot,

L=3.5 ft

¹⁹ T. Starr, Personal Communications, In class handout, 04. Dec. 2016

F. Heat Exchanger Data Sheet

HEAT EXCHANGER SPECIFICATION SHEET												
1	Customer	Wachusett Brewing Company										
2	Plant Location	Westminster, MA	Date:	4/5/2017	Rev.:	1						
3	Service of Unit (Name)	CO2 Process Heat Exchanger			Mark No.(s)	E-101						
4	Size	12-42	TEMA Type:	BFU	Hor/Vert?	Vert						
5	Surf per Unit, ft2	Gross:	61.34	Effective:	55.76	Shells per Unit:	1					
6	PERFORMANCE OF EACH SHELL											
7	Fluid Allocation	Shell Side			Tube Side							
8	Fluid Name	Propylene Glycol-Water sln.			Carbon Dioxide							
9	Flows		In	Out	In	Out						
10	Vapor	lb/hr	0	0	0	1440						
11	Liquid	lb/hr	30600	30600	1440	0						
12	Steam	lb/hr	0	0	0	0						
13	Water	lb/hr	0	0	0	0						
14	Noncond.	lb/hr	0	0	0	0						
15	Temperature	F	28	19.76	1.5	9						
16	Pressure	psig	0	0	300	295						
17	Specific Gravity		0	0	0	0						
18	Viscosity	cp	0	0	0	0						
19	Molecular Wt., Vapor											
20	Molecular Wt., Noncond.											
21	Specific Heat	Btu/lb-F	0.69		0.25							
22	Thermal Cond.	Btu/hr-ft-F										
23	Latent Heat	Btu/lb	N/A		119							
24	Inlet Velocity	ft/sec										
25	Pres Drop, psi, Allow./Calc.		N/A		N/A							
26	Fouling Resistance		0.003		0.003							
27	Heat Exchanged, Btu/hr		174,000	LMTD (Corrected), F	22.070							
28	Overall HT Coefficient, Btu/hr-ft ²		148									
29	CONSTRUCTION OF EACH SHELL											
30		Shell Side			Tube Side		Sketch (Bundle, Nozzle Orientation)					
31	Design/Test Pres, psig		25	37.5	300	450						
32	Design Temp	F	28		2							
33	No. of Passes		1		1							
34	Corrosion Allowance, in.		1/8"		none							
35	Connections	In	2"		2"							
36	Size &	Out	2"		2"							
37	Rating	Intermediate	none		none							
38	No. of Tubes	66	OD, in.	1	Thk, in.	N/A	Length, ft	3.5	Pitch, in.	1.25	Layout	Triangular
39	Tube Type (Plain or Finned)	Plain	Tube Material	SS								
40	Shell Material	CS	ID, in.		OD, in.	12	Shell Cover Mat'l	CS	Integ or Remov.?			
41	Channel or Bonnet, Material	304 SS					Channel Cover Mat'l	304 SS	Integ			
42	Tubesheet (Stationary) Mat'l	304 SS					Tubesheet (Floating) Mat'l					
43	Floating Head Cover Mat'l											
44	Cross Baffle Material		Type			% Cut	Pitch, in.			Inlet, in.		
45	Long. Baffle Material					Seal Type						
46	Supports	Tube	U-Bends		Type							
47	Bypass Seal Arrangement											
48	Expansion Joint											
49	rho-V2	Inlet Nozzle	Bundle Entrance		Bundle Exit							
50	Gasket Mat'l	Shell Side	Tube Side		Fixed Tube							
51	Code Requirements	ASME VIII					TEMA Class	C				
52	Weight per Shell, lb	Empty			Filled w/Water		Bundle					
53	Remarks											
54	Exchanger needs a pressure relief valve which will burst at 50 PSI on the shell side of the exchanger.											
55	Shell Side High pressure alarm also needed so that employees know that they need to shut down system when pressure relief valve blows											
56	Shell side pressure indicator to tell system to shut down required											
57												
58												

G. HAZOP Study

Equipment	Property	Guide Word	Deviations	Cause	Consequence	Frequency	Impact	Priority Number	Action/Safeguards
H-101 (Tube side)	Flow	No	No Flow (Stream 14)	Stream 14 rupture	CO ₂ loss, No heat transfer to glycol, Process delay	1	4	4	Use proper material and regular maintenance; Shut off process heat exchanger system in event of rupture
			No Flow (Stream 15)	Internal Tube rupture	Shell side pressurization	1	4	4	Use of proper material and regular maintenance; Pressure relief valve; Deactivate exchanger system
			No Flow	Flow Control Valve Failure	CO ₂ loss, No heat transfer to glycol, Process delay	4	2	8	Maintenance; close manual valves
		More	More Flow	Increased CO ₂ demand	Not all CO ₂ vaporizes	2	1	2	Flow indicator control (set max flow to 24 lb/min)
					Glycol stream subcooled	2	1	2	Flow indicator control (set max flow to 24 lb/min)
		Less	Less Flow (Stream 14)	Pipe Leak	CO ₂ loss, glycol not cooled sufficiently	1	2	2	Patch leak prior to catastrophic failure
			Less Flow (Stream 15)	Internal Tube rupture	Shell side pressurization	1	4	4	Use of proper material and regular maintenance; Pressure relief valve; Deactivate exchanger system
			Less Flow (Stream 15)	Pipe Leak	CO ₂ loss	1	2	2	Use proper material and regular maintenance; Installation of a flow meter
		Reverse	Reverse Flow	Pressure gradient between Streams 15 and 16	Minimal Heat Transfer	4	2	8	Check valves on streams 15 and 16

Equipment	Property	Guide Word	Deviations	Cause	Consequence	Frequency	Impact	Priority Number	Action/Safeguards
H-101 (Shell Side)	Flow	No	No Flow (Stream 8)	Pump failure	No heat transfer, liquid CO ₂ goes to process	4	3	12	Switch to backup pump; "pump broken" alarm indicator
			No Flow (Stream 8)	Stream 8 rupture	Glycol loss, no heat transfer, Liquid CO ₂ to process	1	3	3	Use of proper material and regular maintenance; close isolation valves and shut down pumps
		More	More Flow (Stream 8)	Too much glycol pumped into line	Glycol not cooled enough	2	1	2	Implement process controls (flow meter and variable speed pumps)
			More Flow (Stream 9)	Internal tube rupture	Shell side pressurization	1	4	4	Use of proper material and regular maintenance; Pressure relief valve; Deactivate exchanger system
		Less	Less Flow (Stream 8)	Pump failure	Less heat transfer, liquid CO ₂ goes to process	2	1	2	Flow indicator control
			Less Flow (Stream 8)	Stream 8 pipe leak	Glycol loss	1	2	2	Use of proper material and regular maintenance
			Less Flow (Stream 9)	Hole in exchanger shell	Glycol loss	1	3	3	Use of proper material and regular maintenance
		Reverse	Reverse Flow	Pipe rupture between pump and exchanger	CO ₂ not vaporized, Glycol loss	1	3	3	Use of proper material and regular maintenance

Equipment	Property	Guide Word	Deviations	Cause	Consequence	Frequency	Impact	Priority Number	Action/Safeguards
H-101 (Tube Side)	Pressure	No	No gauge pressure	Stream 14 rupture	CO ₂ loss, No heat transfer to glycol, Process delay	1	4	4	Use proper material and regular maintenance; Shut off process heat exchanger system in event of rupture
		More	More pressure	Storage tank at higher pressure	None	2	1	2	None
		Less	Less Pressure	Tube rupture	Shell Side over pressurization	1	4	4	Use of proper material and regular maintenance; Pressure relief valve; Deactivate exchanger system

Equipment	Property	Guide Word	Deviations	Cause	Consequence	Frequency	Impact	Priority Number	Action/Safeguards
H-101 (Shell Side)	Pressure	No	No gauge pressure	Hole in exchanger shell	Glycol loss	1	3	3	Use of proper material and regular maintenance
		More	More pressure	Internal tube rupture	Shell Side over pressurization	1	4	4	Pressure relief valve; deactivate exchanger system
		Less	Less Pressure	Blockage in stream 8	None	2	1	2	None

Equipment	Property	Guide Word	Deviations	Cause	Consequence	Frequency	Impact	Priority Number	Action/Safeguards
H-101 (Tube Side)	Temperature	More	More Temperature (Feed)	Heat transfer to environment	Exchanger is underperforming; CO ₂ temperature leaving exchanger too high, glycol not cooled sufficiently	3	2	6	Insulation on Stream 14
			More Temperature (Effluent)	Too much glycol flowing through exchanger	Glycol not cooled sufficiently	3	3	9	Implement process controls (flow meter and variable speed pumps)
		Less	Less Temperature (Feed)	Heat transfer to environment	CO ₂ not vaporized, Glycol overcooled	1	2	2	Insulation on Stream 14
			Less Temperature (Effluent)	Not sufficient glycol flow rate	CO ₂ may not completely vaporize, over cooled glycol	3	2	6	Implement process controls (flow meter and variable speed pumps)

Equipment	Property	Guide Word	Deviations	Cause	Consequence	Frequency	Impact	Priority Number	Action/Safeguards
H-101 (Shell Side)	Temperature	More	More Temperature (Feed)	Heat transfer from environment	Glycol not sufficiently cooled, CO ₂ Temperature too high	2	2	4	Insulation on Stream 7 & 8
			More Temperature (Feed)	Glycol tank temperature too high	Glycol not sufficiently cooled, CO ₂ Temperature too high	1	2	2	None
			More Temperature (Effluent)	Not sufficient CO ₂ flow rate, some vaporized CO ₂ feed to exchanger	Glycol not sufficiently cooled, CO ₂ Temperature too high	1	2	2	Insulation on Stream 9; Implement process controls (flow meter)
		Less	Less Temperature (Feed)	Glycol tank temperature too low	CO ₂ may not completely vaporize, over cooled glycol	2	2	4	None
			Less Temperature (Feed)	Heat transfer to environment	CO ₂ may not completely vaporize, over cooled glycol	2	2	4	Insulation on Stream 7 & 8
			Less Temperature (Effluent)	Higher CO ₂ flow	Glycol is over cooled, not as much CO ₂ vaporization	2	2	4	Implement process controls (flow meter and variable speed pumps)

Equipment	Property	Guide Word	Deviations	Cause	Consequence	Frequency	Impact	Priority Number	Action/Safeguards
Pumps (P-8/9)	Flow	No	No Flow	Pump is off	No flow to heat exchanger	2	4	8	Make sure pump is on
				Pump is broken	No flow to heat exchanger	2	4	8	Backup Pump; Shut liquid CO2 isolation valves and open CO2 vapor;
				Stream 7 rupture	Glycol loss, no flow heat exchanger	1	4	4	Use proper material and regular maintenance; Shut off process heat exchanger system in event of rupture
				No NPSH	Pump does not function	1	4	4	
		More	More Flow	Higher pump speed	More wear on pump	2	2	4	Implementation of controls system (flow meters and variable speed pump)
		Less	Less Flow	Lower pump speed	Less wear on pump	2	1	2	None
		Reverse	Reverse Flow	Heat exchanger tube rupture	Pump breaks	1	4	4	Pressure relief valve on exchanger; deactivate exchanger system

Equipment	Property	Guide Word	Deviations	Cause	Consequence	Frequency	Impact	Priority Number	Action/Safeguards
Pumps (P-8/9)	Pressure	No	No gauge pressure	Pipe rupture, Pipe leak	Cavitation	2	4	8	Regular maintenance to ensure don't lose NPSH
		More	More Pressure	Glycol tank pressurized, more glycol head in tank	None	2	1	2	None
		Less	Less Pressure	pipe leak, Glycol tank at lower pressure or no gauge pressure	Cavitation possible	2	4	8	Regular maintenance to ensure don't lose NPSH

Equipment	Property	Guide Word	Deviations	Cause	Consequence	Frequency	Impact	Priority Number	Action/Safeguards
Pumps (P-8/9)	Temperature	More	More Temperature	Warmer feed	None	2	1	2	None
		Less	Less Temperature	Cooler feed	None	2	1	2	None

H. Sizing of New Pipes

$$\dot{V} = \frac{\dot{m}}{\rho}$$
$$v_{max} = 10 \frac{ft}{s}$$
$$A_c = \frac{\dot{V}}{v_{max}}$$
$$D_{inner} = \sqrt{\frac{4A_c}{\pi}}$$

Propylene glycol (Streams 7, 8 & 9)

$$\dot{V} = \frac{510 \frac{lb}{min}}{63.4 \frac{lb}{ft^3}} = 8.04 \frac{ft^3}{min} * \frac{min}{60 s} = 0.134 \frac{ft^3}{s}$$

$$A_c = \frac{0.134 \frac{ft^3}{s}}{10 \frac{ft}{s}} = 0.0134 ft^2$$

$$D_{inner} = \sqrt{\frac{4 * 0.1345 ft^2}{\pi}} = 0.13065 ft * 12 \frac{in}{ft} = 1.568 in$$

Liquid Carbon Dioxide (Stream 14)

$$\dot{V} = \frac{24 \frac{lb}{min}}{63 \frac{lb}{ft^3}} = 0.378 \frac{ft^3}{min} * \frac{min}{60 s} = 0.0063 \frac{ft^3}{s}$$

$$A_c = \frac{0.0063 \frac{ft^3}{s}}{10 \frac{ft}{s}} = 0.00063 ft^2$$

$$D_{inner} = \sqrt{\frac{4 * 0.00063 ft^2}{\pi}} = 0.0284 ft * 12 \frac{in}{ft} = 1.568 in$$

Vapor Carbon Dioxide (Stream 15)

$$\dot{V} = \frac{24 \frac{lb}{min}}{3.36 \frac{lb}{ft^3}} = 7.14 \frac{ft^3}{min} * \frac{min}{60 s} = 0.119 \frac{ft^3}{s}$$

$$A_c = \frac{0.119 \frac{ft^3}{s}}{10 \frac{ft}{s}} = 0.0119 ft^2$$

$$D_{inner} = \sqrt{\frac{4 * 0.0119 ft^2}{\pi}} = 0.1231 ft * 12 \frac{in}{ft} = 1.478 in$$

I. Calculating Shaft Power of the Pump:

$$\rho = 63.4 \frac{lb}{ft^3} = 2240.3 \frac{lb}{m^3} = 1015.57 \frac{kg}{m^3}$$

$$\dot{V} = \frac{510 \frac{lb}{min}}{2240.3 \frac{lb}{m^3}} * \frac{60min}{1hr} = 13.67 \frac{m^3}{hr}$$

$$g = 9.81 \frac{m}{s^2}$$

Converting Pressure to Head²⁰

$$h = \frac{2.31\Delta P}{SG}$$

$$SG = \frac{\rho}{\rho_{water @ STP}} = \frac{1015.57 \frac{kg}{m^3}}{1000 \frac{kg}{m^3}} = 1.0156$$

$$\Delta P = 5 \text{ psi}$$

$$h = \frac{2.31 \frac{ft}{psi} * 5 \text{ psi}}{1.0156} = 11.373 \text{ ft} = 3.466 \text{ m}$$

Calculating Hydraulic Power²¹

$$Ph = \frac{V\rho gh}{3.6 * 10^6}$$

$$Ph = \frac{13.67 \frac{m^3}{hr} * 1015.57 \frac{kg}{m^3} * 9.81 \frac{m}{s^2} * 3.466m}{3.6 * 10^6} = 0.1311 \text{ kW}$$

Calculating Shaft Power

$$Ps = \frac{Ph}{\eta p}$$

Using heuristic 4 found in Table 11.9 of *Analysis, Synthesis, and Design of Chemical Processes*,²² at flow rate $V = 0.2278 \text{ m}^3/\text{min}$:

$$\eta p \approx 0.40$$

$$Ps = \frac{0.1311 \text{ kW}}{0.40} = 0.3278 \text{ kW}$$

²⁰ "Converting Pump Head to Pressure and Vice Versa." Converting Pump Head to Pressure and Vice Versa. The Engineering Toolbox, n.d. Web. 12 Feb. 2017.

²¹ "Summary." Pump Power Calculation – Neutrium. Native Dynamics, n.d. Web. 12 Feb. 2017.

²² Turton, Richard, et al. (2003) *Analysis, Synthesis, and Design of Chemical Processes*, Upper Saddle River, NJ: Prentice Hall

J. CAPCOST Inputs:

Heat Exchanger Inputs

CEPCI = 576 (average for 2014)²³

Exchanger Type: S/T Fixed Tube Sheet

Tube Side MOC / Shell Side MOC: Stainless Steel / Stainless Steel

$P_{max}(tube\ side) = 300\ psig = 20.7\ barg$

$P_{max}(shell\ side) = 25\ psig = 1.72\ barg$

$A_{gross} = 61\ ft^2 = 5.67\ m^2$

of shells = 1

Pump Inputs

CEPCI = 576 (average for 2014)

Type of Pump: Centrifugal

Materials of Construction: Stainless Steel

P_s (Shaft Power) = 0.328 kW

$P_{discharge} = 25\ psig = 1.72\ barg$

Number of Spares: 1

²³ Jenkins, Scott. "Economic Indicators: CEPCI - Chemical Engineering." Chemical Engineering Economic Indicators CEPCI Comments. N.p., 19 Mar. 2015. Web. 15 Feb. 2017.

K. Determining Cost of the Heat Exchanger:

$$C_a = C_b * \left(\frac{C_a}{C_b}\right)^n$$

$$C_a = C_b * (A_a/A_b)^n$$

C_a = cost of the exchanger we designed

C_b = cost of minimum area exchanger in CAPCOST

A_a = area of the exchanger we designed

A_b = minimum area of exchanger in CAPCOST

n = six-tenths rule

After entering the data for our exchanger into CAPCOST, the following information was known and input into the equation above:

$$C_a = ?$$

$$C_b = \$22,200$$

$$A_a = 61 \text{ ft}^2$$

$$A_b = 107.6 \text{ ft}^2$$

$$n = 0.6$$

Solving for C_a :

$$C_a = \$22,200 * \frac{61 \text{ ft}^2}{107.6 \text{ ft}^2} = \mathbf{\$15,792.96}$$

L. Determining Cost of the Pumps:

$$C_a = C_b * \left(\frac{P_a}{P_b}\right)^n$$

Ca = cost of the pump we designed

Cb = cost of minimum area pump in CAPCOST

Pa = shaft power of the pump we designed

Pb = minimum shaft power of pump in CAPCOST

n = six-tenths rule

After entering the data for our exchanger into CAPCOST, the following information was known and input into the equation above*:

Ca = ?

Cb = \$7,110

Pa = 0.328 kW

Pb = 1 kW

n = 0.6

Solving for Ca:

$$C_a = \$7,110 * \frac{0.328 \text{ kW}}{1 \text{ kW}} = \mathbf{\$3,642.45}$$

*this cost accounts for a spare pump in addition to the main pump

M. Refrigeration Efficiency Calculation:

Efficiency of the existing Glycol Chiller (CO3L10221) from manufacturers²⁴

$$EER = 9.78 \frac{Btu/h}{W}$$

From Engineering Toolbox²⁵

$$\frac{1 kW}{1 \text{ ton of refrigeration}} = \frac{12}{EER}$$

$$1 \text{ ton of refrigeration} = 3.5 kW = 12,000 \frac{Btu}{h}$$

$$\text{Power required (on a 1 ton basis)} = \frac{12 * 12,000 \frac{Btu}{h}}{9.78 \frac{Btu/h}{W} * \frac{1000 W}{1 kW}} = 14.72 kW$$

$$e(\text{refrigeration efficiency}) = \frac{Power_{out}}{Power_{in}} = \frac{3.5 kW}{14.72 kW} = 0.237$$

The refrigeration has an efficiency of 23.7%.

²⁴ Trane, personal communication via phone, February 17, 2017.

²⁵ "Cooling Load - Convert kW/ton to COP or EER." Cooling Load - Convert kW/ton to COP or EER. The Engineering Toolbox, n.d. Web. 25 Mar. 2017.

N. Return On Investment

N.1 Operating Cost per Pound of Glycol

$$\dot{Q} = \dot{m}c_p\Delta T$$

$$\dot{Q} = 1\text{lb}_m * 0.70 \frac{\text{Btu}}{\text{lb}_m^\circ\text{F}} * (28^\circ\text{F} - 20^\circ\text{F}) = 5.6 \text{ Btu}$$

$$\text{Cost (to cool 1 pound of glycol)} = \frac{\dot{Q} * E_r * \frac{1 \text{ kWh}}{3412.14 \text{ Btu}}}{e}$$

$$E_r(\text{electric rate}) = \frac{\$0.10}{\text{kWh}}$$

$$e(\text{refrigeration efficiency}) = 0.237$$

$$\text{Cost (to cool 1 pound of glycol)} = \frac{5.6 \text{ Btu} * \frac{\$0.10}{\text{kWh}} * \frac{1 \text{ kWh}}{3412.14 \text{ Btu}}}{0.237} = \$0.00059$$

N.2 Annual Operating Cost

$$\text{Annual Cost} = \dot{m}_{\max} * t_{\text{operating}} * \frac{\text{Cost}}{\text{lb}_m \text{ glycol}}$$

$$\dot{m}_{\max} = 255 \frac{\text{lb}_m}{\text{min}}$$

$$t_{\text{operating}} = 8 \frac{\text{hrs}}{\text{day}} * 5 \frac{\text{days}}{\text{week}} * 52 \frac{\text{weeks}}{\text{year}} = 2080 \text{ hrs} * 60 \frac{\text{min}}{\text{hr}} = 124,800 \text{ min}$$

$$\text{Annual Operating Cost} = 255 \frac{\text{lb}_m}{\text{min}} * 124,800 \text{ min} * \frac{\$0.00059}{\text{lb}_m} = \mathbf{\$19,072.74}$$

$$\text{Total cost} = \text{Annual Cost} * \text{Life Expectancy of Exchanger}$$

$$\text{Total of operating cost of current system} = \$19,072.74 * 10 \text{ years} = \$190,727.40 \\ \approx \mathbf{\$191,000}$$

$$\text{Total Capital Cost of proposed system} = (\text{pump cost} + \text{heat exchanger cost}) * F_L \\ F_L(\text{Lang Factor}) = 3$$

$$\text{Total Capital Cost of proposed system} = (\$3642.45 + \$15,792.96) * 3 = \$58,305 \\ \approx \mathbf{\$58,300}$$

N.3 Total Savings

$$\text{Total Savings} = \text{Operating cost of current system} - \text{Capital Cost of proposed system}$$

$$\text{Total Savings} = \$191,000 - \$58,300 = \$132,700$$

N.4 Payback Period

$$\text{Payback Period} = \frac{\text{Total Capital Cost of proposed system}}{\text{Annual Operating Cost}}$$

$$\text{Payback Period} = \frac{\$58,300}{\frac{\$19,072}{\text{year}}} = 3.06 \text{ years} \approx 3.1 \text{ years}$$