

**On The Shoulders of Giants:
A Portfolio of My Journey**

A Major Qualifying Project Report
Submitted to the Faculty
of the
WORCESTER POLYTECHNIC INSTITUTE
in partial fulfillment of the requirements for the
Degree of Bachelor of Science
in Humanities and Arts: Drama/Theatre

By:

Sebastian Nickolai Bellisario

Date: February 25, 2013

Susan Vick, Advisor

Table of Contents

1. Abstract	3
2. Executive Summary	4
3. Acknowledgements	5
4. Introduction and Background	6
5. A Journey of Growth	7
6. <i>The Comedy of Errors</i>	21
7. Conclusion	34
8. Appendices	36

1. Abstract

This Major Qualifying Project presents my work as a Humanities and Arts Major throughout my education at Worcester Polytechnic Institute. This paper is a portfolio detailing my educational journey both in the classroom and through hands on work within the theatre community. The project demonstrates the knowledge gained, and is representative of the work necessary in the pursuit of a Theatre Degree.

2. Executive Summary

Worcester Polytechnic Institute offers a unique exposure to the realm of Theatre, combining theory and practice through in class education and work on academic and student productions. My own journey at WPI has taught me invaluable lessons, with each production building upon the experience of the last. Arriving as an eager freshman, I have grown into a central figure within the community. My growth represents a path many students take in their interest and education with theatre at Worcester Polytechnic. Hopefully future students will be able to interpret my work and my experiences to further their understanding and gain insight into program.

3. Acknowledgements

Susan Vick

Erika Stone

And the many wonderful people who've looked after me at WPI

4. Introduction and Background

All thespians are story tellers, and every story has a beginning: mine began in middle school. Middle school represented the beginning of diversity and personal interests. After school activities were increasingly prevalent, and students chose their involvement. At a total loss of what I should do with my time, I attended the annual activities fair with my friends. Drawn by the colored lights and strobe there I joined the realm of technical theatre. The theatre gave me a sense wonder and anticipation I had never yet felt and I instantly fell in love with the activity. Throughout middle school I worked on the productions, and excelled in the program.

High school was an opportunity to take the skills I'd learned and work on significantly more impressive productions. More important was the potential for grow, however my arrogance initially held me back. My self-confidence often challenged others, believing I was always right. Luckily my director set me straight. During my second year I asked to Assist Stage Manage and was confronted about my inconsiderateness. The director gave me a chance but stressed the importance that I improve. His faith transformed me into a better person and taught me qualities appreciated by my peers. I eventually became stage manager and learned to handle responsibility and command a group of students. I ended high school after participating in eleven of twelve productions and took my love of theatre to an engineering school known for its emphasis on the humanities.

5. A Journey of Growth

My education in theatre has been one of practical observation and lessons in theory. I came to WPI in hopes of expanding my knowledge towards becoming an engineer and to push the bounds of my theatrical experience. I wanted to grow and was willing to throw myself into any and every opportunity I could. Every person on campus remembers his or hers first exposure to theatre here, and especially their first show; I am no exception. Looking back on the first meeting during NSO I met those who would become my teachers in the years to come. A green freshmen, full of energy and excitement and ready to be thrown into the grinder, I asked to Assistant Stage Manage.

Short Stack

Short Stack or You've Got To Think Warm Thoughts If You Want To Make It Here by Rolin Jones is show I'll always remember. The play combined comedic vignettes opposite dramatic scenes to create an emotional environment. Working as an assistant stage manager allowed me to interact with various aspects of the production. I developed a working relationship with actors and directors through rehearsals, and assisted the many technical areas to succeed. *Short Stack* introduced me to the process that a production at WPI takes and how much of collaboration is necessary. Most importantly, *Short Stack* exposed me to a number of mentors. Our stage manager taught me almost everything I know about the job. Our producer kept pushing me and supporting my endeavors. My director taught me to never slack when a production depends on it. These people would respect and trust me in the time to come. Your first show in the Little Theatre is always a shock of new experiences and learning, but by the end you gain a community willing to support you.

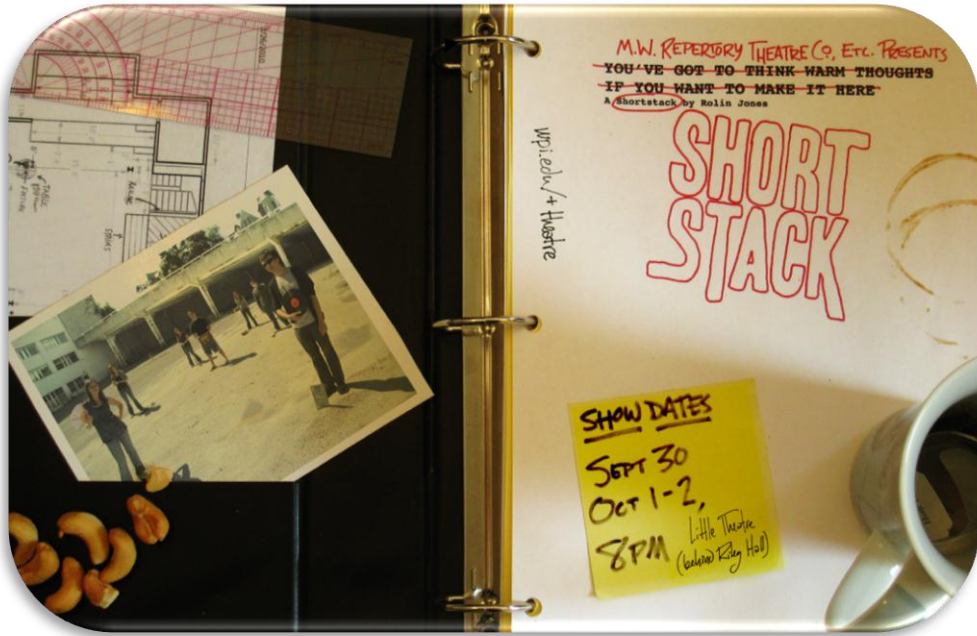

Figure 1: Poster Design For *Short Stack, or You've Got To Think Wark Thoughts If You Want To Make It Here*

As my stage manager, Sam Moniz taught me the responsibilities and expectations of stage management. Above all else, the stage manager is responsible for the director, actors, and calling of the show. In order to uphold his responsibility, he must be involved with every aspect of a production. The stage manager acts as a bridge between rehearsals and the technical work and understands how each aspect of the production should proceed. His job is to make sure the results are representative of the expectations, and to ensure rehearsals and the production run smoothly.

Six Characters in Search of an Author

Six Characters in Search of an Author by Luigi Pirandello gave me an opportunity to verify much of the knowledge I'd gained from *Short Stack* and furthering my understanding. I'd started to understand the expectations, but I wasn't yet ready to stage manage alone, thus I became the assistant again, although under a new production team. Although the process was similar, *Short Stack* seemed like a small group working hard to put a show together, *Six Characters* had more distribution of responsibility and utilized more personal effectively. The cast itself was fourteen actors, often all on

stage simultaneously. Despite the large cast, the director and stage manager maintained control. Understanding how the director and stage manager commanded and organized the group would help me greatly in the coming term.



Figure 2: The set for *Six Characters In Search Of An Author*. Not pictured is a large painted clock face on the floor.

The Laramie Project



Figure 3: A scene from *The Laramie Project*. The shows simplified set allowed the performance to be actor driven.

The end of *Six Characters* quickly brought the excitement of two new shows: the MW Rep production of David Mamet's *American Buffalo*, and the Masque production of *The Laramie Project* by Moisés Kaufman and the members of Tectonic Theater Project. The latter was my first opportunity to stage manage alone, one which I would take on with excitement. I was being given responsibility by people I respected and I desperately wanted to succeed. This drive carried me through the production. My first reading of the play left me watery eyed in a corner of the library. The read through was a similar experience for most. From the onset I had high expectations for the actors, forcing them to be off book quickly with numerous rehearsals. They rose to the challenge and were well prepared, however they became increasingly exhausted and needed extra time to relax. Reflecting back, my fault wasn't the amount of work scheduled but how my expectations were presented to the cast. In the end, the show was an amazing exploration of the town of Laramie, Wyoming, and the story of Matthew Shepard.

Sunday	Monday	Tuesday	Wednesday	Thursday	Friday	Saturday
9 January	10	11	12	13 LT First Day of Class C-term 9-11:30 Full Cast	14	15 Alden Hall 5:30-7:30 Read Through
16	17 5-6 [18,20,27,30,42,43] 9-10 [2,7,13,14,39,50]	18 5-6 [21,22,26,40,41,49] 6-7 [11,12,16,24,35,36,37] 9-10 [1,3,6,44,45,46]	19 5-6 [19,23,28,32,33,34] 6-7 [5,29,31,47,48,51] 8-9 [4,8,9,10,15,17,38]	20 Alden 9-11 Read Through	21 Off book	22 3-4 [14,18,23,43,47,48] 4-6:30 Full Cast <i>Kinekkest</i>
23	24 9-10 [2,7,13,31,39,50] Snow arrive at 8:30	25 5-6 [21,22,26,40,41,49] 6-7 [12,16,17,24,35,36,37] 9-10 [1,3,6,44,45,46]	26 5-6 [5,19,28,30,34,42] 8-9 [4,8,9,10,15,29,38]	27	28 6-7 [11,20,27,32,33,51] 7:15-9:45 Full Cast	29
30	31 5-6 [18,20,27,30,42,43] 9-10 [2,7,13,14,39,50] Snow arrive at 8:30	1 February 5-6 [21,22,26,40,41,49] 6-7 [11,12,16,24,35,36,37] 8-9 [1,3,6,44,45,46] 9-11 Read Through	2 No Line Call 5-6 [19,23,28,32,33,34] 6-7 [5,29,31,47,48,51] 8-9 [4,8,9,10,15,17,38]	3	4 American Buffalo	5 4-6:30 Full Cast 6:30-? Q2Q Cabaret
6	7 Laramie Tech Week 8:30-	8 Laramie Tech Week 8:30-	9 Laramie Tech Week 8-	10 Laramie Tech Week 8:30-	11 Laramie Tech Week 7:15-	12 2-? Q2Q With Actors Vagina Monologues
13 COSMIC BREATH DAY!	14 Laramie Prod Week 6-	15 Laramie Prod Week 6-	16 Laramie Prod Week 6-	17 Laramie Show 6-	18 Laramie Show 6-	19 Laramie Show 6-

Figure 4: Rehearsal Schedule for *The Laramie Project*. The brackets correspond to scenes. Overall, one of the most complicated schedules I've built although it worked surprisingly well around most conflicts.

New Voices 29

"And now for something completely different," or at least that's how I felt. After almost a full year of stage managing, I felt accomplished albeit thirsty for something new. Thus I became the sound designer for *New Voices 29*. I was given a mentor who taught me the system and basic principles, from there I experimented. *New Voices* presented an interesting challenge and the festival nature of the show allowed certain elements to be conveyed through sound alone. I quickly focused on creating effects from a packed night club just outside the door to a dead bolt clicking open mid-stage. I enjoyed the creativity of it, and how it helped establish the world of play. I had to measure my own opinion against that of many directors, and reconcile the differences. I would deal with similar circumstances in my

future design endeavors. After a few long stressful nights, it was nice to relax for the performances and look forward toward the summer's work.



Figure 5: Full company photo from New Voices 29. The festival draws in a lot of personnel, and is an excellent opportunity to get involved in theatre.

The Complete History of America (Abridged)

Finding a director for *The Complete History of America (Abridged)* was surprisingly easy. My good friend need only be asked before taking up the challenge, as I took to producing the show. While not having a budget was frustrating, in the end the biggest problem encountered was staffing. The pool of potential staff dwindled over the summer. A small cast alleviated some worry; however technical staff were few and far between. Those I gathered were hard working, and competent, although I filled a few holes myself. The group worked hard and, carried partially by the three mad men of a cast on stage, the show was a success. It reminded me in many ways of *Short Stack*, a small group working together to

get everything done. In the end the show went off without a hitch and was well received, more than enough to deem the show a success.



Figure 6: A mockup of the poster given to the Director and me as gifts. The words have been replaced with jokes from the production.

I had started off as an assistant stage manager and ended the year producing a show. The journey wasn't nearly complete, and while I had done a lot of managerial work, I intended my sophomore year to be one of exploration into new areas.

Into The Woods

New discoveries would have to wait, as the first role of sophomore year I undertook was stage managing for *Into The Woods*. While I had worked on musicals before, *Into The Woods* had a far greater scope on a much shorter schedule relying heavily on actor's memorization over the summer and a week of full day rehearsals. The director kept control of rehearsals, which alleviated some of my responsibility. However, the production itself lacked leadership from a producer and was consistently behind schedule. Often I found myself sacrificing time to help construction crews late into the night, or

driving long distances to buy materials. The show for me saw two new lows which thankfully I've never repeated.

The first low came less than a week to production. Cue to cue is designed to combine the technical elements with the actors work on stage. This wasn't possible when lighting had nothing programmed. When I thought tech week couldn't run worse the second ordeal struck. Calling the cue to fly in Cinderella's house two days before opening night ended in disaster. I could only watch as the house swung loose into its owners face. I won't soon forget screaming "Hold!" and racing to the stage faster than I thought possible. The actress went to the emergency room but thankfully was alright and performed opening night. Despite excellent performances from the actors, the technical aspect for *Into The Woods* was below the expectation. With more organization and more time, the product would have been significantly cleaner and additionally spectacular.



Figure 7: Andrew Smith performing the role of Narrator from *Into The Woods*.

Cat on a Hot Tin Roof

Cat on a Hot Tin Roof by Tennessee Williams was my first onstage performance and my first scenic design. Both would be extraordinary learning experiences. The initial design took form as I first read the script. Imagining the characters moving through the room, I envisioned how they interacted with each piece of furniture, and where I wanted the audience to focus. The bed commanded the central focus, mirroring Brick and Maggie's relationship issues. Overall, I wanted to draw the audience into the room with the characters and design a space where the actors would feel comfortable within the world of the play. Despite having disagreements over certain elements, the product was gorgeous, and the difference in opinion helped me understand the design process better. I learned especially that input needs to come from many facets.

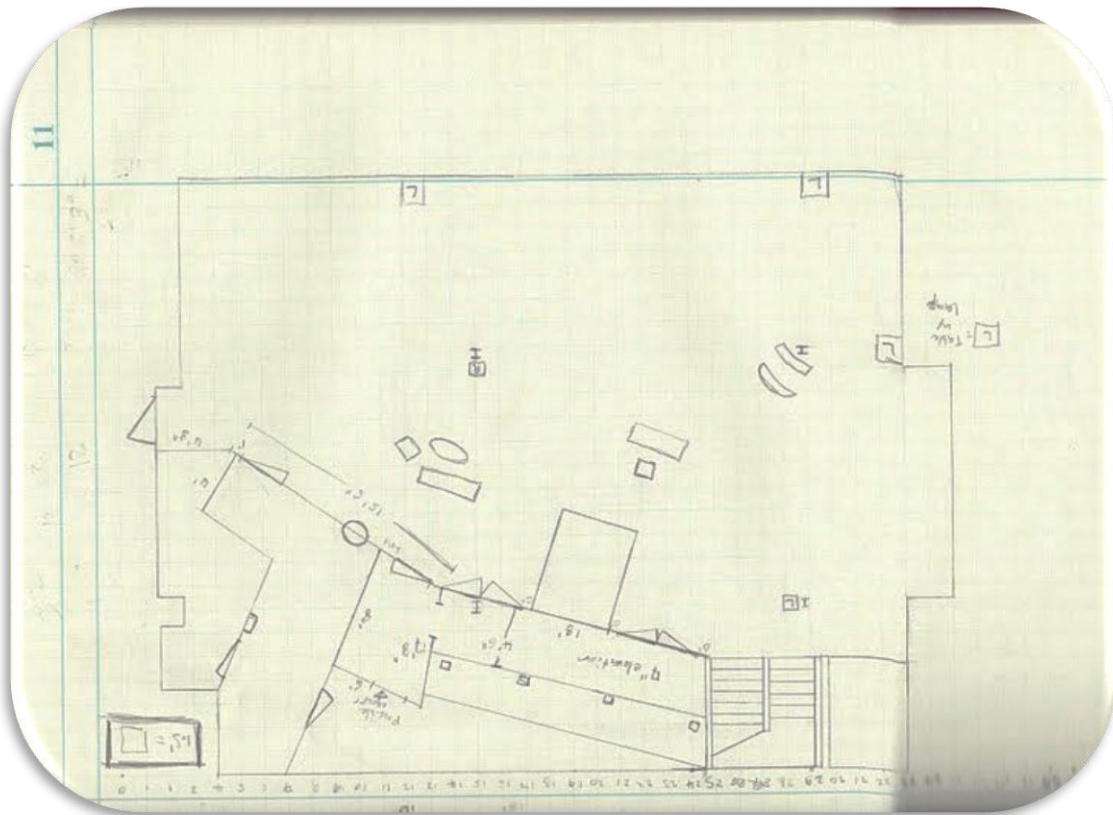

Figure 8: Initial design plot for *Cat on a Hot Tin Roof*

Beyond my work on the scenic design I had the desire to audition. An actor might choose a monologue to audition and put several hours in to preparing. My audition was nothing like that. I had never auditioned for a main stage show and decided to at least attempt for a small role. I did a dramatic reading of the theme from “The Fresh Prince of Bel-Air” which landed me a call back and finally a role. Never in my mind did I even consider getting cast, yet there I was cast as Brick Pollitt. I hoped I was ready to evoke his disgust with mendacity. Looking back, my portrayal of Brick’s sexuality was ambiguous. While I may have known how I felt, I left the audience to decide. If I had the opportunity to play Brick again, I would experiment more with each sexuality. I learned a lot about acting and being an actor from the production and was given a chance to bond with my peers. Tofer Carlson, Big Daddy, in particular demonstrated professionalism continuously throughout the production, and was a model to follow. Moreover, he worked with me to ensure that I was ready for the performance, and saved our scenes more than once on stage. I learned that in every role we take, we must go out of our way to help our peers for the betterment of the production and each other, and that professionalism is key to distinguished friendship and production work.



Figure 9: An intense moment between Brick and Maggie, showing both the allure and tension of their relationship.

C term is always a mad house. Filled with productions from multiple organizations, actors and crew become thin. Often people take on multiple responsibilities between the productions to ensure the work is completed. I decided to design and build the set for *Collected Stories* by Donald Margulies, and was interested in directing for *Hindsight!*

Collected Stories

Collected Stories got off the ground first. The MW Rep production took place at the start of term to allow turn over for the Masque production toward the end of term. As such the majority of my work both in design and construction would occur over break. *Collected Stories* is the story of two writers, one who's established, and the other who's still working on her first work. The former becomes both teacher and mentor, only to force the young woman away when she feels threatened. The show centers in the mentor's living room complete with her desk, book shelves, and window. I wanted to create the space, but also take certain elements into the abstract. I sculpted books, by soaking them in water and glue overnight. The result was incredibly malleable, and allowed me to create interesting positions for each book. Further I aspired to paint words in different fonts across the floor and set. This did not happen, however, because the director preferred a more realistic representation.

Hindsight!

Simultaneously, I was selected as a director for *A Prayer for Rain* and *Lumberknight: The Francophone Protocol*, as part of *Hindsight!* The plays are thematically very different leading to a unique vision for each show. *Lumberknight* was designed to be high energy and challenged my ability to direct a large group of people, and create successful comedic moments. *A Prayer for Rain* had a much more subtle and contrived air. While I had a clearer vision for *Prayer* it was often more difficult to express my notes, and have actors embody my vision. I'm proud of *Hindsight!* but it left me thirsty to direct a full length show, something I've unfortunately yet to undertake.

New Voices 30

With spring rapidly approaching, preparations for *New Voices 30* were well underway featuring eight new works including one of my own. Having *Golden* performed was an exciting yet terrifying experience, particularly waiting for the audience to react, and seeing if the jokes and characters are as I imagined. I gave the director free clearance to interpret the script as he saw fit, although I realize now I should have been more invested in the director's vision.

New Voices 30 was also my second chance to perform on stage. I auditioned with a difficult piece, something which I believe worked against me. However, I did get called back for a very interesting role in *Poems: The Early Life of Pope John Paul II*. After rereading the script I felt an affinity toward the role of Director, but arriving at callbacks showed me the extent of actors available. In the end I was cast as a dancing zombie for the show *Land of the Living... Living?* The role as a zombie was a physical challenge without learning to dance Thriller. With the choreography added I undertook something entirely outside of my comfort zone, and surprisingly performed without issue. I enjoyed my time among the undead, especially the ability to scare people at will.



Figure 10: How I looked as I dragged my body across the theatre. Additionally I'm about to vomit blood.

A Midsummer Night's Dream

The summer of 2012 offered me a different perspective on theatre. While working an internship in California, I auditioned for Caltech's summer production of *A Midsummer Night's Dream*. Seeing the audition poster seemed like fate, and I was cast in the role of Demetrius. The entire production felt a breath of fresh air. The group was incredibly inviting and by the end I felt like a part of their company. The show reminded me of the wonder of theatre, not simply on the stage but the magic which created a spectacular performance and the camaraderie between players. This camaraderie is something I hope to inspire in my peers.



Figure 11: I'm attempting to remove Helena from my leg in the role of Demetrius.

Legacy Of Light

My return from California was also my return to stage management. *Legacy of Light* is one of the smoothest shows I've worked on. Of the six actors, not a single one had trouble learning their lines. Moreover, the group bonded well and their chemistry translated to the stage. *Legacy* was the first show which urged me to encourage the new faces. With four new performers to the Little Theatre I

began to realize that if I didn't pass knowledge on to them, I would be failing my mentors who taught me. Moreover, the program would decline. This understanding has been difficult to follow through with, but is an ongoing process which I intend to accomplish.



Figure 12: Company photo from *Legacy of Light*

6. *The Comedy Of Errors*



familiarizing myself with important elements of the play. While I read, I began to imagine how the characters would move through space, and how they interacted with the scenery. I also determined which pieces were important to include. The action focuses around the Antipholus' home, and areas of Ephesus. To represent these I split the stage into two areas: a marbled area and a stone area. The former represents the home, while the latter represents a market square of the town. I also included a church area in a corner to be used in Act 5. Once I had a general layout of how the space would look I discussed my ideas with the director. An early discussion helps keep communication clear and ensures that the director and designer are consistent in their visions.

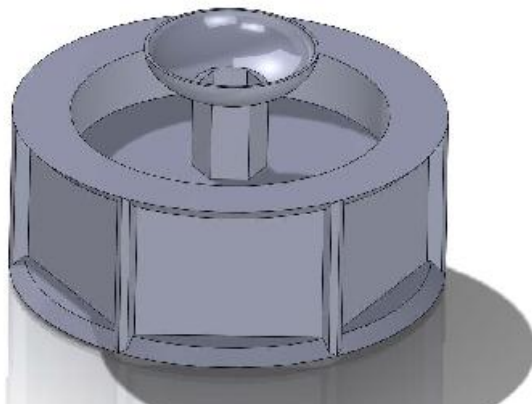

Figure 15: Initial fountain design made using Solid works. The final version removed the round geometry in place of a hexagonal design.

Once the general ideas had been formulated I moved on to solidifying the layout. I began creating pieces to fit within the theatre, not too much to overpower the space but enough to create the world. For the market I wanted several stalls for goods to be sold and to create the feel of a bustling market town. Additionally, I wanted a fountain to balance the set towards the audience and help create the market feel. The fountain also added a dynamic nature to the set. The house area would have a marble floor to convey the wealth of Antipholus along with a marble table for dinner to be served. The table also helped fill the space while creating a play area for the actors. Between the two areas, a half

wall would distinguish the differences without obscuring view. The entrance to the home would be part of this wall, although without an actual door. The door's absence allowed the Dromios to argue while mirroring each other in order to add to the confusion of the play.



Figure 16: The twin Dromios at the door.

The church was one of the harder elements to design. It has an important presence in the final act to help reveal the twins, however it was unused during the remainder of the show. The duality led to a more subtle approach which could be highlighted with lighting to demonstrate its sudden importance. After moving the chapel to several different parts of the set, I settled on the south east corner of the Little Theatre. The corner is often over looked by the audience, as it isn't typically used. Further, instead of building a formal structure black fabric was hung and using window gobos created the church effect.



Figure 17: An image showing the finalized sundial.

One of the later elements to be incorporated in the design was a sundial. The play takes place over the course of a single day, the sundial would act as a way of conveying that passage of time. Additionally, its distinct presence helped to identify the scenes in the market, and acted as an axis for those scenes to revolve around. The initial sundial was a quarter sphere, but due to manufacturing difficulty a hexagonal pedestal design was selected. The hexagon shape also connected to the hexagon fountain creating cohesiveness in the scene.



Figure 18: Artistic sketch of the back wall from *The Comedy of Errors*

Finally, I looked at how paint was going to be used on the floor and walls. I used painted marble floors for Antipholus' house. I kept the color scheme to mostly yellow and white to keep a light feel to the house. The marble also gave the impression of coating the interior walls by having marble creep up the bottom of the half wall. The remainder of the floor was painted as large stone slabs placed and flattened to make an ancient road effect to cover the square. The design was made to match many archeological sites including Ephesus. Lastly, the back wall was going to become the city walls of the town. To accomplish the city wall effect, the back wall was painted as large sandstone slabs, stacked high to create the wall. In order for this to work, the windows in the Little Theatre needed to be covered in a believable manner. I designed a banner which would cover one window, while wooden caps were built to disguise "damage" to the wall. The banners were inspired by similar pieces used in the production of *A Midsummer Night's Dream* I. By painting so much of the theatre, the space encompassed the performance, but was large enough and open enough not to stifle the action.



Figure 19: Left: Early paint work of the marble flooring. Right: Final marble effect before the lines were pulled up.



Figure 20: Banner design for *The Comedy of Errors*

Evaluation of the Design and Product:

The design was hugely successful and created a unique experience for those with the opportunity to enjoy it; however the project was not without shortcomings. These shortcomings, while mostly implementation issues, also included design and communication problems. The lack of support in the day to day work on the scenography slowed the entire process down, and ultimately led to certain elements which weren't fully realized. The lack of running water in the fountain drastically affected its purpose and perception. The fountain still balanced the space and tied into the remainder of the market, but the lack of a dynamic element made the piece too stagnant. White fabric columns were built around the I-beams to help hide their presence and add to the entire effect. LED fixtures were supposed to be mounted inside to change their color at will. The columns would allow the director and lighting designer to add a mood to a scene. Unfortunately, between confusion in how the design was expressed, and lack of planning by the crew heads, when the lights were being installed they didn't fit inside the fabric.

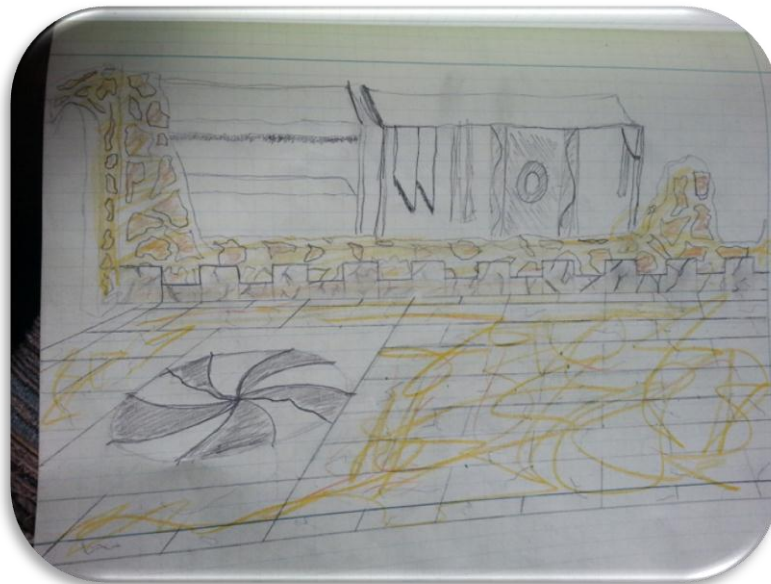

Figure 21: Artistic Sketch of the Antipholus' house for *The Comedy of Errors*.

If I were to re do the design certain elements would have been different. The half wall ended up much larger than I had initially intended, a problem that wouldn't have arisen if designed slightly differently. The look I wanted to achieve was to have the wall appear to be fading away as if the set was actually a cut away. Initially, I thought a three dimensional wall would produce this look. During the process I realized that removing the depth to the wall and having the carved stones extend above the wall would emulate the effect closer. Further, the play space for the market was often limited to one section and for certain scenes was too small. I'd convert some of the marbled area of the house into market area, potentially even switching the location of the stalls and the house altogether. Additionally certain parts of the design were expressed as images and ideas but lacked direction as to implementation. Including additional information about how the different elements would be constructed is important both to maintain the design and ensure the entire design is completed.



Figure 22: Photo taken from the south bank showing the completed scene.

The Antipholus of Syracuse



Figure 23: The Antipholus of Syracuse being courted by someone he believes to be a witch.

The Comedy of Errors also represented my fourth acting opportunity and the most difficult. Each role I've taken on has presented unique challenges in discovering the character. The Antipholus character caused me particular difficulty in understanding how he interacts with others and what he is thinking. Moreover, the physicality of the character was difficult to emulate, especially when mimicking a twin.



Figure 24: The two Antipholus' meet for the first time since birth.

The production began especially rough in terms of memorization. Once I've run a scene several times memorization becomes significantly easier. I can connect the emotion and my voice to the lines I'm saying. Learning the intonation is important so the meaning is portrayed, especially with Shakespearean language. The actors were asked to memorize before rehearsals began in order to expedite the process. This expectation led the first week of rehearsals to be focused on the memorization, and not on characterization. This hamstrung my understanding of the interactions with the other actors on stage as well as the understanding of my character.

In an attempt to find Antipholus, I picked a role model to emulate. In this case I chose the character Richard Castle. Castle has a certain amount of swagger, while also exhibiting extreme behavior in dangerous situations. These represent the two faces my character would take: the fearful suspicious

side that he displays toward the majority of the town folk, and the controlling familiar side he shares with Dromio. Choosing a role model helped to ascertain the emotions which I needed to convey as well as which pieces were still missing. Most important of these was the fear Antipholus fosters throughout the play. His fright of the supernatural goes far beyond my own personal fears, and believing that fear is fundamental.



Figure 25: Dan Murray as Dromio of Ephesus, explaining his strange events of day.

The final challenge my character presented is his energy level. As the play progresses he becomes more worked up over his fear. Maintaining that level of energy without over shadowing anyone was a constant balance. Moreover, maintaining that level while off stage involved a conscious effort. This process became significantly easier as Dromio and I started to play off each other more. Our banter lent itself to grow in energy building toward the end of our scenes making it easy to keep that

energy throughout. In the end, after all the internalization and thought, there comes a point when you throw out all inhibition and simply perform, and *Antipholus* was no exception.



Figure 26: One of the final images from *The Comedy of Errors* depicting the rising action before the reveal of the second Antipholus. Pictured are from left to right: Peter Leper, Dolan Murvihill, Dylan Shields, Kaija Roy, Joesph Brown, and Kristin Brann

7. Conclusions

A portfolio project is about more than one accomplishment I endeavored to complete. This project represents the collected knowledge and experience I've gained at Worcester Polytechnic Institute. I've learned an immense amount about all types of creative contributions to theatre production, from technical work which requires time and skill, to managerial work ensuring others are completing the tasks assigned to them. Moreover, I've pushed myself to learn new skills and attempt new roles, including auditioning for my first role onstage. The program at WPI is built on the education in the class room, and the mentorship of our peers working on the productions themselves. Without dedicated faculty and students the capability of the company would dwindle and I intend to pass on as much knowledge as I can. Our motto of theory and practice is truly active within the theatre program at WPI.

My time here has also taught me an important element in every company. The best shows we've produced were based on a sense of camaraderie among the personnel. This felt like each person was a piece of the whole, all working tirelessly not simply to complete their responsibilities but to create an awesome performance. My mentors understood this and encouraged it in the company. I stand on the shoulders of giants because my peers, colleagues, and mentors lifted me up, encouraged me, and fostered my growth. They made me a part of the company and showed me excellence. As I look back I understand my responsibility to pass on the knowledge I've gained. I must become a giant to stand on and lift up my peers so that they may stand even higher.



8. Appendices

1. Work Log	37
2. Play List	40
3. Bibliography	43
4. Theatre Resumé	44
5. Previous Works	45

Work Log

Activity	Date	Hours
Script Reading	20-Jun	4
Script Reading	21-Jun	4
Scenic Design Work	1-Aug	2
Scenic Design Work	9-Aug	3
Scenic Design Work	15-Aug	2
Meeting	2-Sep	1
Scenic Design Work	13-Sep	3
Scenic Design Work	14-Sep	2
Scenic Design Work	22-Sep	4
Scenic Design Work	30-Sep	3
Auditions	1-Oct	4
Meeting	5-Oct	2
Read Through	8-Oct	3
Memorization	9-Oct	3
Scenic Design Work	13-Oct	4
Memorization	14-Oct	3
Scenic Design Work	17-Oct	2
Memorization	18-Oct	3
Scenic Design Work	20-Oct	3
Memorization	20-Oct	3
Rehearsal	22-Oct	3
Meeting	22-Oct	2
Meeting	23-Oct	1
Memorization	23-Oct	3
Rehearsal	23-Oct	2
Scenic Design Work	24-Oct	2
Paint Test	25-Oct	5
Memorization	25-Oct	2
Rehearsal	25-Oct	3
Scenic Work	26-Oct	4
Memorization	26-Oct	2
Rehearsal	26-Oct	2
Scenic Work	27-Oct	4
Memorization	27-Oct	2
Rehearsal	27-Oct	3

Scenic Work	28-Oct	5
Memorization	28-Oct	3
Meetings	29-Oct	3
Memorization	29-Oct	2
Scenic Work	29-Oct	4
Rehearsal	29-Oct	2
Scenic Work	30-Oct	5
Memorization	30-Oct	3
Meetings	30-Oct	3
Memorization	31-Oct	2
Scenic Work	31-Oct	4
Rehearsal	31-Oct	2
Memorization	1-Nov	3
Scenic Work	1-Nov	4
Rehearsal	1-Nov	2
Memorization	2-Nov	2
Scenic Work	2-Nov	5
Rehearsal	2-Nov	3
Memorization	3-Nov	2
Scenic Work	3-Nov	5
Rehearsal	3-Nov	4
Memorization	4-Nov	1
Scenic Work	4-Nov	4
Rehearsal	4-Nov	3
Scenic Work	5-Nov	4
Rehearsal	5-Nov	2
Memorization	6-Nov	2
Scenic Work	6-Nov	3
Rehearsal	6-Nov	3
Memorization	7-Nov	4
Scenic Work	7-Nov	2
Rehearsal	7-Nov	3
Memorization	8-Nov	1
Scenic Work	8-Nov	4
Rehearsal	8-Nov	3
Scenic Work	9-Nov	4
Rehearsal	9-Nov	4
Cue to Cue	11-Nov	5
Tech Rehearsal	12-Nov	6
Dress Rehearsal	13-Nov	6
Preview	14-Nov	6

Performance	15-Nov	6
Performance	16-Nov	6
Performance/Strike	17-Nov	7
Meeting	19-Nov	1
Meeting	26-Nov	2
Writing	27-Nov	2
Writing	28-Nov	1
Writing	30-Nov	2
Writing	2-Dec	2
Writing	4-Dec	3
Writing	8-Dec	1
Writing	14-Dec	1
Writing	18-Dec	4
Writing	20-Dec	1
Writing	26-Dec	3
Writing	2-Jan	1
Writing	5-Jan	2
Writing	9-Jan	2
Writing	11-Jan	3
Writing	10-Jan	2
Writing	14-Jan	2
Meeting	15-Jan	1
Writing	15-Jan	2
Writing	19-Jan	3
Writing	21-Jan	2
Writing	24-Jan	1
Meeting	29-Jan	1
Writing	29-Jan	2
Writing	2-Feb	1
Meeting	5-Feb	1
Writing	5-Feb	2
Writing	7-Feb	2
Writing	10-Feb	2
Writing	12-Feb	2
Writing	13-Feb	3
Total		315

Play List

Ainely, Elena	<i>Poems: The Early Life of Pope John Paul II</i>
Albee, Edward	<i>The Goat or Who is Sylvia?</i>
Anderson, Jane	<i>Defying Gravity</i>
Beckett, Samuel	<i>Catastrophe</i>
Bellisario, Sebastian	<i>Golden</i>
Betterworth, Jez	<i>Jerusalem</i>
Bishop, Barton	<i>Things Fall (Meanwhile)</i>
Blodgett, Anika	<i>Dora's Disclosure</i>
Brecht, Bertolt	<i>Caucasian Chalk Circle</i>
Carlson, Tofer	<i>A Prayer For Rain</i>
	<i>A Spy By Any Other Name</i>
	<i>Land of the Living...Living?</i>
	<i>The Experiment or Let Them Eat Cake</i>
	<i>Lunch With Walt</i>
Carr, Thomas	<i>Informercial</i>
Ceslips, Fred	<i>A Lesson On Trolls</i>
Chiacchiaro, Rhiannon	<i>Eleven Zulu</i>
Clark, Patrick Sean	<i>Everybody Poops, But You</i>
Connick, Robert & Wilkins, Andrew	<i>Behind Cloths Doors</i>
Darensbourg, Catherine	<i>Thank You for Flushing my Head in the Toilet</i>
Dorf, Jonathan	<i>A Shot in the Dark</i>
Faulkner, Megan	<i>Danish Soap or Danes of Our Lives</i>
Filichia, Peter	<i>Jake</i>
Fischer, Laura & Saari, Erin	<i>One Card From Caving In</i>
Fletcher, Holly	<i>The Golden Apple</i>
Fliperd, Tess C.	<i>Bludpayne VII: The Return of Bludpayne</i>
Frakes, John	<i>Final Dress Rehearsal</i>
Gerstenberg, Alice	<i>He Said She Said</i>
Gionfriddo, Gina	<i>After Ashley</i>
Gonzalez, Jose Cruz	<i>Salt and Pepper</i>
Gozzi, Carlo	<i>The Green Bird</i>
Gray, I. M.	<i>A Mad Breakfast</i>
Gregg, Stephen	<i>This is a Test</i>
Hampton, Christopher	<i>The Philanthropist</i>
Hayes, Hillary	<i>Transaction Completed</i>
Hwang, David Henry	<i>M. Butterfly</i>
Ives, David	<i>Polish Joke</i>
John Cariani	<i>Almost Maine</i>
Jones, Rolin	<i>Short Stack or You Have To</i>

Kaufman, Moise
King, Louisa
Kopit, Arthur
Lansley, Oliver
Lindsay-Abaire, David
Linney, Romulus
Long, Adam Martin, Reed & Tichenor, Austin

Mamet, David
Margulies, Donald
Mode, Becky
Moliere
Moore, Alison
Murillo, Carlos
Murphy, Gerald P.
Neilson, Anthony

Neuman, Colleen
O'Donnell, Dean
Odets, Clifford
Osborn, Christopher
Pirandello, Luigi

Rand, Jonathan
Raspanti, Celeste

Ripps, N. Harrison
Rock, Alexander
Rosenberg, James

Rostand, Edmond
Ruhl, Sarah

Russell, Tom
Shaffer, Peter
Shakespeare, William

Simon, Neil

*Think Warm Thoughts If
You're Going to Make it Here*
Laramie Project
Barbecue Chicken Pizza
Chamber Music
Ernest and the Pale Moon
Rabbit Hole
A Lesson Before Dying
*Complete History Of America
(Abridged)*
*The Complete Works of
William Shakespeare
(Abridged)*
American Buffalo
Collected Stories
Fully Committed
The Miser
Slasher
Dark Play or Stories for Boys
Blind Date Inc.
*The Wonderful World of
Dissocia*
Lion and Mouse Stories
I Travel
Waiting for Lefty
Lumberknight
*Six Characters In Search Of
An Author*
Check Please
*I Never Saw Another
Butterfly*
Searching For Something
Grave Intentions
*The Death and Life of Sneaky
Fitch*
Cereno du Bergerac
*In The Next Room or The
Vibrator Play*
Damn the Torpedos
Black Comedy
As You Like It
Hamlet
Macbeth
Much Ado About Nothing
Romeo and Juliet
Twelfth Night
Comedy Of Errors
A Midsummer Night's Dream
California Suite

Simpson, Angela
Sodaro, Craig
Sophocles

Stoppard, Tom

Tucker, Matt

Unknown,
Wassermen, Dale

Wilde, Oscar

Williams, Tennessee
e

Zacarias, Karen
Zimmerman , Mary

Zolidis, Don

Yellow Jacket

Salem's Daughters

Antigone

Oedipus

Oedipus at Colonus

Rosengrantz and

Guildenstern are Dead.

as seen through a coffee
shop window

The Second Shepherd's Play

One Flew Over The Cockoo's
Nest

The Importance of Being
Earnest

A Street Car Named Desire

Cat On a Hot Tin Roof

Legacy of Light

The Secret in the Wings

Metamorphosis

The Brother Grimm

Spectaculathon

Musicals

Alegria

Anything Goes

Bombay Dreams

Carmen

Chicago

Fiddler On The Roof

Guys and Dolls

How To Succeed in Business Without Really

Trying

Into The Woods

Kouza

La Traviata

Les Miserable

Lion King

Porgy and Bess

Spamalot

Spring Awakening

The Drowsy Chaperone

The Magic Flute

The Producers

Urinetown

Wicked

Young Frankenstein

Zarkana

Bibliography

Jones, Rolin. *Short Stack or You've Got To Think Warm Thoughts To Make It Here*

Kaufman, Moise. *The Laramie Project*

Lapine, James, and Stephen Sondheim. *Into The Woods*

Long, Adam, Reed Martin, and Austin Tichenor. *The Complete History of America (Abridged)*

Margulies, Donald. *Collected Stories*

Pirandello, Luigi. *Six Characters In Search Of An Author*

Shakespeare, William. *A Midsummer Night's Dream*

Shakespeare, William. *The Comedy Of Errors*

Williams, Tennessee. *Cat On A Hot Tin Roof*

Zacharias, Karen. *Legacy Of Light*

Theatre Résumé

Sebastian Nickolai Bellisario

781-929-4617

snbell@wpi.edu

THEATRE EXPERIENCE

<i>Blithe Spirit</i>	Producer	Antipholus of Syracuse
<i>The Comedy of Errors</i>	Scenic Designer	
<i>Legacy of Light</i>	Stage Manager	
<i>A Midsummer Night's Dream</i>	Demetrius	
<i>New Voice 30</i>	Dancing Zombie	
<i>Hindsight!</i>	Director	
<i>Collected Stories</i>	Scenic Designer	Master Carpenter
<i>Cat on a Hot Tin Roof</i>	Scenic Designer	Brick
<i>Into The Woods</i>	Stage Manager	
<i>Complete History of America (Abridged)</i>	Producer	
<i>New Voice 29</i>	Sound Designer	
<i>The Laramie Project</i>	Stage Manager	
	Assistant Stage Manager	
<i>Six Characters in Search of An Author</i>	Assistant Stage Manager	
<i>Short Stack</i>	Assistant Stage Manager	

Previous Works:

1. Decent into Darkness	46
2. The End Is Nigh	65
3. Show Report for New Voices	72
4. Theatre Workshop Report	75
5. Outbound	76
6. Theatre Workshop Scenic Design	79
7. Golden	81
8. Feast and Festival	84
9. Theatre Workshop Costume And Properties Design	90
10. Theatre Workshop Sound Design	97
11. Theatre Workshop Lighting Design	99

Descent Into Darkness

By: Sebastian Bellisario

Humanities and Arts Course Sequence:

HI 2331	Science Technology and Culture in Early American History	A '10
EN 2222	Theatre Workshop	D '11
EN 1221	Page to Stage	B '11
TH SV	Acting	B '11
EN 3222	Forms In World Drama	C '12

Presented To: Professor Vick
Department of Humanities and Arts
D Term 2012
HU 3910

Submitted in Partial Fulfillment
The Humanities & Arts Requirement
Worcester Polytechnic Institute
Worcester, Massachusetts

Abstract:

Descent into darkness explores the creation, and development of a character from *Land of the living... Living?* from audition to performance. The paper was created using the analysis, and research skills from previous classes and ISP's, which enabled me to both create a believable character, as well as report on how I created them.

Table Of Contents

Abstract.....2
Project Outcome.....4
Journal.....5
Playlist.....16

Project Outcome:

Looking back on the process I find myself comparing my approach to Zombie Soulja Boi, to my approach to Brick in *Cat on a Hot Tin Roof*. While the two roles are perhaps completely different, my approach to each one could have been the same and wasn't. During *Cat on a Hot Tin Roof*, I internalized as much information as Brick as I could. I felt that I would step out of my own self and step into him. I tried to really embody Brick as the person and pull his ideas and thoughts into my own. Once I had processed that the physical movement became a side effect to some extent. I could attach my sorrows to the drink and see the reason in it and feel the calm that it brought. However, my approach to my Zombie was completely different. The zombie as a role, is a physical embodiment of a fictional creature. One which has relatively simple needs and wants. Hunger drives the horde to find food and continue to fuel the system, but such a basic instinct while relatable and understandable, doesn't leave much in the realm of wants driving action. This is especially apparent when not eating. The zombie becomes almost docile as it chooses not to take action. As such, I took a different approach. While using the internal thoughts to assist during the more violent food scenes. I focused on the physical side of how a Zombie moves, sounds, and looks, I tried to emulate what they did, and used that to help drive my action. By understanding how I moved, I could understand why I moved. We meander because we are ever searching for food, but have much less of an urgency about it than most animals. Seeing the way I looked once the full costume came together changed how I would control my face or move through the room; leading with different parts of my body. Between the two roles I felt more connected to Brick, although I'm hesitant to say that's the better method. Focusing on the physical helped to enlighten certain aspects I was trying to create and is incredibly important for the development of a character. Even my broken leg during *Cat on a Hot Tin Roof* helped illuminate how Brick reacted to the space and other characters. If there is one thing that being a Zombie has helped me appreciate, it's how much the appearance and physical traits influence the final product, and how they must be examined in order to portray an honest representation.

Journal:

Monday March 12th

We held the Theater Faire today. I'm very upset with SGA. I sent them an email over a day ago to be forwarded to students and they haven't even responded. It's the first day of classes do they really believe that no one would want to send an email out to the student body? The lack of common sense is rather appalling and extraordinarily frustrating especially when we had to scramble to put the Theatre Faire together in the first place. At least the event went relatively well. People mostly came from Riky's class but I'm glad that there were people to talk to and advise. Plus I think the mock auditions really helped some people. Paige in particular seemed a lot more relaxed and confident. Thoughts for B-Term, start earlier and publicize a lot more. It's not simply about getting people who are already interested it's about getting people who've never been involved in the first place.

Tuesday March 13th

First round of auditions happened today. I don't really like going on the first day, although it probably would have been a good idea. I don't have an audition piece yet and am slightly worried about it. I always find it difficult picking a good audition piece. I'd like to take something from a TV show because they definitely haven't been performed here anytime soon and because there is such a wealth of pieces to pick from. Perhaps I'll do something from Doctor Who or Battlestar Galactica; I've been enjoying both shows as of late and there are some intriguing speeches in both. I'm torn because on the one hand I feel like I should actually choose some text for my audition but I kind of feel like I should just make it up. Not necessarily a full improv, but I could go up with a decent idea of what I want to talk about and then just make up the specific lines as I go. Not sure, guess I'll figure that out tomorrow. Also scheduling Alpha Psi stuff has been surprisingly difficult but we've moved the meeting up to Thursday to avoid Blood Bath.

Wednesday March 14th

So I went with a monologue from *Battlestar Galatica*. I honestly didn't really like the way it turned out. I just didn't have the time to put it together as I would have liked. I suppose that in a way it's my fault for taking so long to pick it but the Fates kind of conspired against me. I'd seen the monologue while watching the show, and remembered that it was pretty intense and had a good show of intensity; however I couldn't find the monologue anywhere, so I went and transcribed it myself. The problem being that once I had finished, my computer decided to crash and lose everything I had been working on. Followed by picking my friend from the train station and a rapid re-transcribing of monologue and printing, I was plagued by only having about 30 minutes to rehearse. Moreover, the monologue wasn't simply a speech by one man but was a verbal thrashing that was dispersed with shorter lines by other characters which drove action. So I played multiple parts which felt stretched and that I didn't use them to my fullest. In retrospect, I would have cut their lines and just acted like they had said them. Or have just made it up. In all honesty I think that would have been my best option based on one quality; that I would have enjoyed it more and I know for a fact that an actor who enjoys where they are and what they are doing is so much more convincing. All well, I have one call back for tomorrow for *Poems*, so hopefully that will go well.

Thursday March 15th

There were a surprising number of people at the *Poems* call back. It started off fairly small and just grew so quickly. By the end there were at least 15 people in the room. Slightly intimidating but there all people I knew and there's really no sense worrying about them. I thought my call back went well though. I played both parts during the call back with several different partners but I could play either role. The director was a very interesting character to investigate. He really isn't a simple character by any stretch of the imagination. He constantly is showing his student the reasons and impulses which should both drive his poem but also show the pertinent reflections he has on the world around him. And he's clever and constantly poking fun at his student. I'd be fine with either role but the director would be fun, plus who knows how blood bath goes. I almost want to be in Dora just to see Giovanna direct, but we shall see.

Saturday March 17th

Bloodbath was last night. Heard some fairly interesting events transpired but they were done in a relatively short period of time. I'm going to be a dancing Zombie in *Land of the Living... Living?* I'm honestly slightly disappointed, I know that the zombies are going to be a significant role, but I did really want a simple speaking role. I wanted to be able to develop a character and present something to the best of my ability. Plus it feels like there wasn't a role in the rest of the festival so I got dumped into being a zombie. Ironic that I went into *Cat* auditions expecting nothing and being the lead and I came into this so much more confident and ended up being in the extra pool. So it goes as they say. I wise man once said that we are given 24 hours to be disappointed and frustrated that we didn't get the role that we wanted, and after that it becomes about the work that needs to be done. And that's a philosophy worth following. It just interesting being on this side of the phrase.

Monday March 19th

Had our first Zombie rehearsal today. It was definitely difficult. I've never learned any sort of choreography before at all plus some of the people already learned some stuff during call backs. I thought it went ok overall. I'm not having trouble with any of the execution it's just the combination of trying to remember what moves I should be doing when while also trying to continue dancing while keeping up with the music. Thriller is going to be challenge for most people. I talked to Anika and she said I was doing pretty well. It's hard to tell when you can't see yourself and when you've never danced before to judge your progress. It was enjoyable to be up there learning but I wish we would run things a few more times before learning new moves. There's only so much data that I can commit to memory.

Sunday March 25th

I finished watching *The Walking Dead*, as part of my research on zombie movement and actions. There were really two main observations that I made. The first regarding how zombies move. Interestingly enough, the zombie shamble moves at a pace slower than what I initially anticipated. They are wandering, mostly without intention, where I feel that our zombie shamble so far has been at least for the initial entrance a little too guided. Once we get inside I think our zombies spread out well into just a meandering group. Beyond that, I also noticed that the speed at which their zombies move while pursuing food was almost at a run. In a large open space this wouldn't really be a problem however, in the Little Theatre there is only so much space to travel. I think moving at a pace closer to that of a brisk walk would be more appropriate. Outside of simply observing their movement, the sounds they made were also very interesting. It was a complex combination between deep haunting hisses mixed with groans and snarls. The hissing in particular was quite haunting.

Monday, March 26th

We learned the Soulja Boi today; it was quite a bit of fun actually. Hip hop is all about relaxing and just kind of moving through the motions fluidly. Anika wants me to be Soulja Boi for the show which I'm kind of excited for. I did it fairly well; I'm just worried about some of the choreography that I keep skipping. It's easy to play it off when I'm supposed to be doing something separate but it can also just look out of sorts. This also kind of locks in a character for me, I wasn't really sure what flavor of zombie I wanted to be. Now I have a decent idea while also establishing what kind of costume I'm going to need. I'd like to go with some jean shorts which means I'm going to have to create wounds for my legs. If possible I'd like to see if I could do a sort of bone sticking out of my leg kind of thing. I talked to Sarah and we're going to get a piece of wood and see if we can sculpt off of it to create something. Hopefully it'll turn out well.

Sunday, April 1st

Alas a lot has happened. So earlier I went out to good will to pick up pieces for a costume. I had a basic idea going into the trip but once I was there, I managed to pick out some really nice pieces. I ended up getting a blue baseball hat, baggy jean shorts, a t-shirt and a sweatshirt. Plus Sarah found some Zombie bling that works perfectly. Afterward, I got a chance to make some of my more permanent wounds that I would be applying every night. I built a bite mark into my left arm which is going to get all bloody and I put a large gash across my right arm. Finally, Sarah and I built up a big wound around a piece of dowel I broke off, to create the effect of having a bone poking through. I'm really glad with how they turned out and I know they'll only look better once their covered in makeup. It's quite an interesting process to create these wounds. You start by creating a base layer alternating latex and toilet paper adding layers depending upon how big you want your wound to be, then you essentially rip and tear at the piece to create the effect of skin being torn away from the flesh. I also destroyed some of my cloths today. I really wanted them to look like they had been exposed to the elements. The image that kept coming to mind was that at some point I probably dragged myself through mud, dirt, and all sorts of grime, so I tried to emulate that. I also torn up my sweat shirt vigorously to try and prevent myself from overheating on stage. I'm definitely am less worried about the physical aspect, but a full run of the show gets me out of breath after the first few dances. We have a couple more rehearsals but tech week is fast approaching and it's going to be interesting.

Monday, April 9th

Tech week! Woo! Today was the first run which we ran pretty much everything. There was a full test of blood and everything tonight and it turned out fantastic. It was a lot of work going through the whole process for the first time all at once but it turned out well and I wasn't too rushed over all. The wounds really looked amazing once they were all done up with makeup. It was interesting seeing how decrepit and rotten I could make myself look. Some of the other zombies had a light to medium amount of makeup on their skin, where as I found that I was really changing my entire look. Which I feel is as realistic as can be. Again this idea of being exposed to the wilderness combined with a lack of fine motor skills would leave us filthy and I think I accomplished it. Unfortunately one of my wounds did fall off during one of the dances. I don't think I applied enough latex to create a solid enough bond. Something to change for tomorrow. The contact lenses worked flawlessly too. They were really tough to get in because I've never had to wear any before but they do really pull the effect together. Plus all good reviews from everyone who watched so it should be a good week going forward.

Saturday, April 14th

A long week, but a good week. It's always a tough week, you run the show so much, trying to perfect everything you can and always making more and more progress. You struggle through and really by Friday and Saturday you're dead tired. At least, that's how this week felt. Yet, you look back thinking that all the work you did is over in almost too quick of a crescendo. I'm glad it's over, that feeling of accomplishment mixed with knowledge that I can finally rest a little.

Play List

Ainely, Elena	<i>Poems: The Early Life of Pope John Paul II</i>
Albee, Edward	<i>The Goat or Who is Sylvia?</i>
Anderson, Jane	<i>Defying Gravity</i>
Beckett, Samuel	<i>Catastrophe</i>
Bellisario, Sebastian	<i>Golden</i>
Betterworth, Jez	<i>Jerusalem</i>
Bishop, Barton	<i>Things Fall (Meanwhile)</i>
Blodgett, Anika	<i>Dora's Disclosure</i>
Brecht, Bertolt	<i>Caucasian Chalk Circle</i>
Carlson, Tofer	<i>A Prayer For Rain</i>
Carlson, Tofer	<i>A Spy By Any Other Name</i>
Carlson, Tofer	<i>Land of the Living...Living?</i>
Carlson, Tofer	<i>The Experiment or Let Them Eat Cake</i>
Carr, Thomas	<i>Lunch With Walt</i>
Ceslips, Fred	<i>Informercial</i>
Chiacchiaro, Rhiannon	<i>A Lesson On Trolls</i>
Clark, Patrick Sean	<i>Eleven Zulu</i>
Connick, Robert & Wilkins, Andrew	<i>Everybody Poops, But You</i>
Darensbourg, Catherine	<i>Behind Cloths Doors</i>
Dorf, Jonathan	<i>Thank You for Flushing my Head in the Toilet</i>
Faulkner, Megan	<i>A Shot in the Dark</i>
Filichia, Peter	<i>Danish Soap or Danes of Our Lives</i>
Fischer, Laura & Saari, Erin	<i>Jake</i>
Fletcher, Holly	<i>One Card From Caving In</i>
Fletcher, Holly	<i>The Golden Apple</i>
Fliperd, Tess C.	<i>Bludpayne VII: The Return of Bludpayne</i>
Frakes, John	<i>Final Dress Rehearsal</i>
Gerstenberg, Alice	<i>He Said She Said</i>
Gionfriddo, Gina	<i>After Ashley</i>
Gonzalez, Jose Cruz	<i>Salt and Pepper</i>
Gozzi, Carlo	<i>The Green Bird</i>
Gray, I. M.	<i>A Mad Breakfast</i>
Gregg, Stephen	<i>This is a Test</i>
Hampton, Christopher	<i>The Philanthropist</i>
Hayes, Hillary	<i>Transaction Completed</i>
Hwang, David Henry	<i>M. Butterfly</i>
Ives, David	<i>Polish Joke</i>
John Cariani	<i>Almost Maine</i>
Jones, Rolin	<i>Short Stack or You Have To</i>

Kaufman, Moise
King, Louisa
Kopit, Arthur
Lansley, Oliver
Lindsay-Abaire, David
Linney, Romulus
Long, Adam Martin, Reed & Tichenor, Austin

Long, Adam Martin, Reed & Tichenor, Austin

Mamet, David
Margulies, Donald
Mode, Becky
Moliere
Moore, Alison
Murillo, Carlos
Murphy, Gerald P.
Neilson, Anthony

Neuman, Colleen
O'Donnell, Dean
Odets, Clifford
Osborn, Christopher
Pirandello, Luigi

Rand, Jonathan
Raspanti, Celeste

Ripps, N. Harrison
Rock, Alexander
Rosenberg, James

Rostand, Edmond
Ruhl, Sarah

Russell, Tom
Shaffer, Peter
Shakespeare, William
Shakespeare, William
Shakespeare, William
Shakespeare, William
Shakespeare, William
Shakespeare, William
Simon, Neil
Simpson, Angela
Sodaro, Craig

*Think Warm Thoughts If
You're Going to Make it Here*
Laramie Project
Barbecue Chicken Pizza
Chamber Music
Ernest and the Pale Moon
Rabbit Hole
A Lesson Before Dying
*Complete History Of America
(Abridged)*
*The Complete Works of
William Shakespeare
(Abridged)*
American Buffalo
Collected Stories
Fully Committed
The Miser
Slasher
Dark Play or Stories for Boys
Blind Date Inc.
*The Wonderful World of
Dissocia*
Lion and Mouse Stories
I Travel
Waiting for Lefty
Lumberknight
*Six Characters In Search Of
An Author*
Check Please
*I Never Saw Another
Butterfly*
Searching For Something
Grave Intentions
*The Death and Life of Sneaky
Fitch*
Cereno du Bergerac
*In The Next Room or The
Vibrator Play*
Damn the Torpedos
Black Comedy
As You Like It
Hamlet
Macbeth
Much Ado About Nothing
Romeo and Juliet
Twelfth Night
California Suite
Yellow Jacket
Salem's Daughters

Sophocles	<i>Antigone</i>
Sophocles	<i>Oedipus</i>
Sophocles	<i>Oedipus at Colonus</i>
Stoppard, Tom	<i>Rosengrantz and Guildenstern are Dead.</i>
Tucker, Matt	<i>as seen through a coffee shop window</i>
Unknown,	<i>The Second Shepherd's Play</i>
Wassermen, Dale	<i>One Flew Over The Cuckoo's Nest</i>
Wilde, Oscar	<i>The Importances of Being Earnest</i>
Williams, Tennessee	<i>A Street Car Named Desire</i>
Williams, Tennessee	<i>Cat On a Hot Tin Roof</i>
Zacarias, Karen	<i>Legacy of Light</i>
Zimmerman, Mary	<i>The Secret in the Wings</i>
Zimmerman , Mary	<i>Metamorphosis</i>
Zolidis, Don	<i>The Brother Grimm</i>
	<i>Spectaculathon</i>

Musicals

<i>Alegria</i>	<i>Porgy and Bess</i>
<i>Anything Goes</i>	<i>Spamalot</i>
<i>Bombay Dreams</i>	<i>Spring Awakening</i>
<i>Carmen</i>	<i>The Drowsy Chaperone</i>
<i>Chicago</i>	<i>The Magic Flute</i>
<i>Fiddler On The Roof</i>	<i>The Producers</i>
<i>Guys and Dolls</i>	<i>Urinetown</i>
<i>How To Succeed in Business Without Really Trying</i>	<i>Wicked</i>
<i>Into The Woods</i>	<i>Young Frankenstein</i>
<i>Kouza</i>	<i>Zarkana</i>
<i>La Traviata</i>	
<i>Les Miserable</i>	
<i>Lion King</i>	

Time Sheet

Date	Hours	Purpose
9-Mar	5	Scripts
13-Mar	2	Class
13-Mar	2	Auditions
14-Mar	2	Auditions
15-Mar	1	Callbacks
16-Mar	1	Journals
16-Mar	4	Walking Dead
17-Mar	6	Set
19-Mar	2	Rehearsal
23-Mar	2	Class
24-Mar	2	Rehearsal
25-Mar	4	Walking Dead
26-Mar	2	Rehearsal
26-Mar	1	Journals
30-Mar	2	Class
31-Mar	2	Cloths Making
1-Apr	2	Rehearsal
1-Apr	3	Wound Making
2-Apr	2	Rehearsal
5-Apr	3	Q2Q
6-Apr	2	Rehearsal
9-Apr	7	Dress
10-Apr	6	Dress
11-Apr	6	Preview
12-Apr	6	Performance
13-Apr	6	Performance
14-Apr	7	Performance
16-Apr	2	Paper
20-Apr	1	Class
27-Apr	2	Class
2-May	2	Paper
3-May	2	Paper
4-May	4	Paper
Total	103	

The End Is Nigh

Sebastian Bellisario

Cast of Characters:

Dave: Young man, Starts with a gun.

Carl: Young man.

Kate: Young woman.

Sarah: Young woman.

Sister Mariah: Sister from the Cloister of St. Augustine. Is older than the rest

Lights come up on an empty stage save for a few discarded raggedy pieces of furniture. It is the living room of a several weeks abandoned apartment. The end is nigh is painted on the walls in what appears to be blood. The lights should be flickering throughout. Two gun shots are heard then the door busts open as everyone but Dave enter frantically.

Dave: *off* Everybody get inside quick!

More gun shots.

Sarah: What are we going to do!?

Carl: Calm down.

Kate: There's more coming!

Sister Mariah: What do we do!

Dave: *Enter with gun.* They're coming block the door. Quickly!

The group hurriedly barricades the doors and windows. Banging and clawing noises can be heard from outside the occasional scream can be heard from far off.

Carl: Grab the furniture.

Sarah: Someone help me with this!

Sister Mariah quietly prays to herself.

Kate: What the hell is going on?

Dave: Not sure but I'd rather not find out first hand.

Carl: Is anyone hurt? Did they get any of you? *Carl checks them out.*

Sister Mariah: I'm alright.

Sarah: Fine.

Dave: I'm good.

Kate: I'm ok.

Sarah: Who the hell are they?

Carl: You think they're people? As far as I'm concerned they are nothing more than animals.

Sister Mariah: The lord hasn't given up on us, who are you to pass judgment on them?

Dave: You know the sermon doesn't help with blood on your face. *Sister wipes her face.*

A scream is heard.

Kate: The screams don't help either.

Carl: Alrighty, if you don't have a weapon find one. You there, come with me let's check these rooms.

Dave: Oh sure, my names, Dave.

Carl: Carl, nice to meet you come on.

They exit briefly to search the few other rooms. Sister Mariah remains standing still, while Kate and Sarah search for weapons.

Sarah: My names Sarah.

Kate: Kathryn, well I guess just Kate, no sense in being formal.

Sarah: Nice to meet you. And what's your name?

Sister Mariah: Huh? Oh my name, they call me Sister Mariah.

Sarah: Well sister it's good to have you with us.

Sister Mariah: Yes well perhaps I shouldn't be. Excuse me.

Kate: Oh ok. So Sarah where you from?

Carl and Dave Enter

Dave: Apartments clear, there's no back door though, just windows and bars.

Kate: Any food?

Carl: Nope. None that we found. I'm Carl by the way.

Kate: Kate.

Sarah: Nice to meet you I'm Sarah, and that's Sister Mariah (*Sister Mariah acknowledges*). You're Dave right?

Dave: Right, good to meet you.

Two gun shots are heard close by

Sister Mariah: There's someone outside!

Kate: Jesus we have to help him

Sarah: Hey! You!

Dave: Shut up he doesn't know we're here.

Sister Mariah: You would leave him?

Dave: Or what take down the barricade to try to help him. He's dead meat.

Carl: He's coming this way!

Sarah: Let him in quick!

Dave: Shits

They move to take down the barricade as banging at the door begins.

Andrew: *(Off)* PLEASE LET ME IN! FOR GOD SAKES LET ME IN! I JUST WANT TO LIVE!

Andrew lets off his final two shots.

Andrew: Please I need to find my son!

Kate: We're trying hold on!

Andrew: Faster! Faster! Oh God OH GOD!!!!!! (He screams as he is attacked and killed. The screams are drawn out over a long period. The group ceases removing the barricade and listen to the man die. Sarah vomits off to one corner. Sister Mariah cough/gags but manages to compose herself. Dave kicks Carl and motions toward the door. Carl nods and they rebuild the barricade.)

Kate: So what do we do now?

Dave: Survive. It's the only option.

Carl: Not technically.

Dave: I'm sure the Sister'd have something to say about that.

Kate: Most of us would.

Sarah: We need to leave.

Carl: We're safe here.

Sarah: And for how long.

Carl: You saw what happened to that man.

Sarah: Which is why we need to get as far away as possible.

Carl: But-

Dave: She's right. We don't have any food. We won't last very long before becoming desperate. However, we could use at least a few hours rest.

The group continues to move about the room, eventually relaxing and sitting

Kate: So what do you think it is? Disease? Virus?

Carl: Government conspiracy? I'm kidding.

Sarah: Anything is possible I spose. I just wish I knew what is happening to them.

Dave: Doesn't much matter does it? They're dead aren't they.

Kate: Of course it matters. And we don't know that for sure.

Dave: Look outside what do you see. Blood and bodies. Nothing else. They're dead as a door knob.

Sarah: We get it. What about you Carl?

Carl: Honestly, don't know and don't care. So long as they stay away. What about you sister?

Sister Mariah: "And they shall cover the face of the earth, that one cannot be able to see the earth: and they shall eat the residue of that which is escaped, which remaineth unto you from the hail, and shall eat every tree which groweth for you out of the field."

Lights flicker then Blackout.

Sarah: What's going on?

Kate: I don't know!

Dave: It's alright, your eyes will adjust shortly, just stay calm.

Carl: Dark will be easier to sneak around in too huh?

Kate: Possibly.

Sarah: In this situation I would gladly take vision.

Dave: Who knows no lights might end up saving us.

Sarah lets out a piecing scream, as she is caught by something in the darkness.

Sarah: Oh my god, get it off me GET IT OFF! *Sarah lets out a scream and a gurgle as her throat fills with blood.*

Carl: What's going on?

Kate: Jesus, someone help her!

Dave: Sarah where are you? (*Sarah lets out her final sounds and dies*) What's going on?! Sarah? I'm going over there.

Kate: Dave don't!

Carl: I'm getting out of here!

Dave and Carl cross the room. Carl makes for the door and begins shifting the barricade in the dark. Dave moves toward Sarah's screams.

Dave: If you open in it now well die!

Carl: And we're dead in here anyway!

Kate: No!

Kate lets out a brief choke of air. And falls to the ground dead.

Carl: Kate no!

Carl rushes toward Kate but lets out a brief exclamation of pain, then hits the floor with a thud, and is silent.

Dave: Carl stay where you are! DON'T MOVE! Carl.....? CARL! Shit, shit, shit. (*Lights should become dim as his eyes start to adjust*) I have to get out! (*Dave tries to move but the coach is too much for him alone*) I have to get out! Fuck it's too heavy. What was that? Is someone there?

Jesus Christ! (*Lights flicker on momentarily revealing the carnage that has occurred. Four dead and bloody bodies lie about the room. Lights flicker immediately out*) Oh good my eyes Jesus. I can't see. (*Rustling and heavy breathing can be heard*) What? Who's out there?! Sarah?!

Carl?!.... I'm going to die. Jesus there's blood everywhere. I'm going to die. Fuck. Fuck. I'm.....I'm sorry. I... I... I tried.

(Flash as gunshot goes off on stage followed by silence. The lights flicker after a few moments, revealing the Sister eating Carl. She briefly screeches. Blackout).

Show Report:

Wednesday the 13th and Saturday the 17th

Overall, *A Lesson on Trolls* was well crafted and preformed monologue. The actress used a large portion of the set, as well as kept herself from becoming static in one section of the set. Moreover, she was able to replicate the blocking effectively every night. Her use of the main platform to introduce the trolls, when she is explaining how regeneration works, created a new region of her world with which she could demonstrate without encroaching on the rest of her monologue. The lights were used to create a warm summery day in a light forest effectively. The use of green gobos specifically gave the impression of sun coming through leaves. Unfortunately, the radius of the gobos was so small that the effect did not cover the whole scene, and led to some strange looks when she entered or exited the gobos light. The light bird noises helped to create the illusion of a forest without being overbearing. The costume and props for the show were mostly complete. They helped create the world of the play, and fitted the script perfectly. The show used all the aspects to effectively create the world of the play.

A Shot In The Dark, made excellent use of effects to help convey the world of the play. The production used well defined areas to establish both of the apartments as well as the hallway. The set up for the women's apartment was simplistic but well established a sitting area as well as the illusion of an old person apartment. The lighting as well contributed to the warmer feeling of both of the rooms, and to showing distinction between the hallways, and the apartments. Many necessary effects which contributed to the world came from sound. The gunshot end up being effective but was not a perfect sound effect to use. The other effects such as the door knock were executed perfectly, and made believable the lack of an actual door. The costumes were appropriate for the age of the ladies. And the props on stage helped establish the apartment in a major way. The production well portrayed the setting and used the effects to draw in the audience well.

A Spy By Any Other Name, combined major and more subtle effects to establish the show. The introduction to the show made excellent use of the stage as well as sound and lights. The actress spent moved around the entire space, while the music and lights gave the feel of a James Bond-esque introduction. For the rest of the play, while centralized around the 'bench' was the best option, and when movement was allowed by the script the actress filled the space well. The lights were appropriate for a bright summer day and allowed for the energy of the scene to flow well. Again subtle park noises helped establish location without being too obtrusive. The props and costumes for the show were also well selected showing the contrast between the two characters, as well as enhancing comedic elements. The show used the effects to create a comedic spectacle as well as to subtly enhance the remainder of the show.

The longest of the shows, *Everybody Poops But You*, used the stage to establish different areas and scenes, placing the school and the doctors area well partitioned. This change of area and location was enhanced by sound and lights. Lighting between any two scenes was distinctly different, but in a consistent manner. Once a location, i.e. the doctor's office, was established, the lighting was the same for each scene in that location. This allowed the audience to quickly remember where the lighting had been scene previously and helped encapsulate the audience. The bell to signal the change of scene was a useful wipe to each scene, while being subtle enough that it could be used multiple times without becoming annoying. The costumes for the children and the doctor were well thought out and believable, however, I felt that Robert was not nearly Robot enough for the role. While his costume was appropriate, I wanted his make-up to be more extreme in the direction of robot. Also I felt that while Cheri's dress at the end definitely separated her from the group, I felt the specific choice of dress required her to wear a tank top beneath it, which created a strange look. Overall, an excellent show which made good use of sound and lights to cover the many transitions throughout the show.

One Card From Caving In, was a much more subtle show in terms of effects. The coffee table and chairs were well created from a few small blocks and a table cloth, and by placing the entrance stage left, the actors could act their entrances and provide a slight buffer from the main scene. The lights were set to provide a very neutral beginning to the scene allowing for the contrast at the end when the reveal was allowed. However, I felt the special at the end of the show was too much of a change for such a short period. The song choice for the show, also seemed to contrast with the overall feeling of the show. The costumes for the show well portrayed who the characters were; however, I would have liked to see more of the actors faces. In terms of effects, the show didn't need many, and thus relied more on acting than technical aspects.

Searching for Something on a technical level differed from most of the other shows. The actors used most of the stage throughout their search, and their progression through the space gave the feeling that they were searching through a much larger space. Despite their search using the space well, the victim was placed in a manner which centralized the scene in a difficult to see section, placing her directly behind an I-beam, and far away from the south bank. Lighting did an excellent job of establishing the Borealis, however if the show was produced outside of the festival it would have been interesting to place wool, or painted luan so that the effected wasn't reflected off of the ceiling. The wind, helped to establish location as well as create tension when it was removed for part of the scene. The costumes and props were used well, but could not be seen, more flashlight on the actors, and less on the audience would have allowed the audience to be more encapsulated in the world that show had created.

The Experiment, or, Let Them Eat Cake, made excellent use of the stage. Not only was the blocking the same every night, but it used the space in a way which prevented the monologue from become stagnated in center stage. While the cake never moved, the actors movement around the cake, made it central and allowed her to play off of the cake like another character. Lighting created the fake florescent looking light of a lab well while the light bulb hanging from the grid gave an excellent effect, I wish it had turned on when mentioned during the show. Sound could have been used in a more subtle way during the show, however silence also allowed for the monologue to stand alone. The simplicity of everything besides the cake, allowed the focus to stay on the cake, instead of the actor wearing a flashy costume.

Yellow Jacket, made excellent use of lighting and sound to create a nightclub behind the wall of the closet. While the lights were seen over the curtain, which was technically a wall, they helped to establish that there was a club behind the wall, and the audience readily accepted that the lights represented the club. Also when the door opened, and the lights could be seen better, they had the desired effect. The sounds of the door opening and closing, really sold the fact that the curtain was actually a door, as well as, when was the door supposed to be open or closed. Costumes and props for the show all worked excellently and help to established the space in an effective manner. Overall, *Yellow Jacket* used all the aspects to effectively recreate a space that is in general, hard to recreate.

EN 2222 Report

Sebastian Bellisario

EN 2222

Erica Stone

5/3/11

The differences between acting on stage and doing technical work, only comes from when that work is complete. On the technical side, a designer's work should be done, before the show opens, same goes for any of the technical crews, and while things change during the production, the majority of the work is handled beforehand. With acting, the performance is the completion. All the 'design' work has been completed, its simply time to create in the theatre those designs like any technical crew would, however this work happens with an audience watching. Acting shows off its work, while the technical aspects hide it, and it would be interesting if technical theatre was a performance in itself. Would people work harder or more efficiently if there was an audience for a light hang? Overall, while this is not my first time acting on stage, I have taken this in many ways more seriously, and it has been an excellent change of pace.

In addition to acting, I also mentored Paige with sound, as well as a few other people. Mentoring was an extremely enjoyable opportunity. It allowed me the ability to teach people how to properly do the jobs they had taken on, without having to take over for them. Watching each person, start to understand how to do their jobs, as well as watching them take the knowledge I had given them, in a short period of time, and apply it to each of their shows in different and interesting ways gave me a sense of pride. In addition, it showed me that explaining how to do something and having that person try themselves, instead of simply doing that activity while they watch is a much more effective method of teaching.

Outbound

By Sebastian Bellisario

Cast of Characters:

Guy 1: Young Male

Guy 2: Young Male

Guy 3: Young Male

Woman: Young Woman attracted to women

Guy 4: Young Male

Girl on the Train: Fairly attractive woman. Should be dressed fairly casually but with good sense. It is just another day to her.

There is a girl standing on a train. Guy 1 sits down the car from her.

Guy 1: So you see a girl on the train. But you can't talk to her. And then it's your stop. (*Guy 1 gets off the train*) You hope it's her stop too, but it's not. So, I keep going.

Guy 2: (*Guy 2 enters and sits down the car from her.*) So you see a girl on a train, but you can't talk to her. So you think maybe I'll just smile at her. And you wait for her to look, she fakes you out, and again. And just as I'm going to give up, finally she glances over. But I'm just smiling and staring at you, and you prolly think I'm creepy, and it's my stop, (*Guy 2 gets off the train*) so I just get off. I glance back but nothing.

Guy 3: (*Guy 3 enters and sits down the car from her.*) So there is this ugly chick on the train. But she's caught my attention. And she's not really ugly she's just different. And the more I look at her I realize she's actually quite beautiful. She's smiling at the little girl at the end of the car, and her eyes shining. And I'm about to say something but I can't. I'm too afraid. (*Guy 3 gets off the train*) And I realize it's my stop and instinct kicks in so I hop off. And I look back, but she's gone.

Woman: (*Woman enters and sits down the car from her.*) So there is this girl on a train, and she's got a nice ass, but it's like my mother said, I'm a freak, what am I supposed to do go up and ask her to a cup of coffee. She'd prolly just laugh at me. Or maybe just run away. So I just sit, I try not to look at her but I can't stop. I sit here waiting and my stop won't come quick enough. Our eyes catch for a moment, and she smiles, but I just blink and look away. I'm afraid. And as the train pulls into the station, I quickly move out, (*Woman gets off the train*) but I secretly hope she'll magically run after me; even if it is just for a cup of god damn coffee.

Guy 1: (*Guy 1 enters and sits down the car from her.*) So here I am. Back on the train. Looking at the same beautiful girl. I mean it's not the same one but, they're all the same aren't they. Same beautiful girl on the same train I take every day. So I'll sit here, not talking to her until it's my stop but not her's, and I'll get off and look back and nothing will happen. Nothing ever happens. No matter how many times smile, no matter how many times I kick myself, or scream inside my own head. Nothing ever happens. (Pause the train stops, the girl goes to get off, as she hits the platform, the guy pauses then rushes after her) Excuse me! Um..... Hi.

Blackout

Mini Project: Scenic Design:

NV 29

My design was to essentially create a versatile stage within the theatre. The varying levels allow directors to use them as they see fit as, whether that be simply to have someone enter from above or to show that certain characters have greater power over others. The overall shape and flow of the set was designed so that interaction with the set could be used significantly in one show, but allow play space in front of the set should shows prefer to work off of the floor. The different play areas can allow for scene changes within a play quite easily as well which for shows like *Everyone Poops But You* is really necessary. Aesthetically the cascading down from its highest level is pleasing, especially as an entrance. Overall the set seeks to maximize play space while allowing for as many options that directors could feasibly want.

As for materials, 3 4x8 Platforms, 4 4x4 Platforms, and 3 4x4 Triangle Platforms create the basic structure of the design. The other important element is the curtain. Providing the entire back drop for the set it also serves to hide back stage and to make the space a slightly more intimate space. This will work well for the festival nature of New Voices. Unfortunately, an aspect I was not able to incorporate due to the lack of curtain, was to have a curtained off path way through the backstage which audience members would be able to enter and exit from, allowing them to be pulled into the set by the fact that they would need to walk on the set to

enter. The curtain could then be opened up so that backstage crew and actors could cross and have access.

Golden

By Sebastian Bellisario

Cast of Characters:

Dog: He's a dog.

Man is on stage. He is staring at a "fire hydrant" most likely done in pantomime. Pauses and looks up to audience.

Dog:

What the fuck.

What the Fuck.

Someone pissed on my hydrant. What kind of sick ass sniffer comes here and decides to piss on my hydrant, you know. What kind of undignified ball licking, leg humping, slobber-fest, thinks they deserve this over me. I mean I work hard for this. How many papers has that inbred fetched, huh? Mutt. You know, I play with the kids, I sit with the old man when he's watching football. Who brings the ball back when you throw it. I do that's who. *Pause* It'll never smell the same again. You know it wasn't always such a dog eats dog world. There used to be cats. And Poodles. Man I love those flapper dogs, hair done up in a ball. They used to prance up main street and I'd stand right here. Proud. Pissing on my hydrant. Now look at it. Bet some young wiener dog thought it'd be funny. GOOD ONE SHIT SNIFFER! You know, it was eleven years ago when I first pissed on this hydrant, and did I take it from someone? No! It was given to me. Old Al, god rest his tail, he was the old fire house dog, used to run by here every morning while those firemen would grab their breakfast. First time we ever met was at this hydrant, and I respected that it was his! We used to bark up a storm whenever the mailman would walk by. Well I guess there's no other choice. I guess I just piss and move on. Here we go hydrant its just you and me now. (*Moves to pee on the hydrant, then stops*)

Feast and Festival

Since the birth of Theatre, it has been used as a means of entertainment and celebration. The Greeks, known for their extravagant festivals, often incorporated the use of drama and comedy in their festivals. Actors would perform both for the merriment of the crowds as well as in honor of the Gods. These traditions became tied to theatre as it continued to grow through the centuries. By the 17th century, theatre had transformed from festivals to regular entertainment for the masses. As the Colosseum had housed the entertainment of Rome, The Globe Theatre housed plays for the masses of London. The main source of such works is William Shakespeare; writing over 36 plays. However there is one play which exemplifies the festive qualities that the common people of London thrived upon; *Twelfth Night or What You Will*. One of Shakespeare's better known Comedies, it is important to recognize the original nature of the performance in order to bring the play into the modern era without sacrificing the festive characteristics.

The play uses specific elements with the intent to entertain a large audience. The main conceit that the play adapts is that Sebastian and Viola are Fraternal Twins, separated by a terrible storm and believe each other dead. Viola, who finds herself suddenly stranded in a new land, disguises herself as a man in order to fit in and gain entry to Orsino's court. Shakespeare is using dramatic irony to his advantage. By allowing the audience the knowledge that Viola is truly a woman the audience reacts to the scenes differently than many of the actors. While Olivia becomes ever more attracted to Cesario(Viola), Viola continually refutes her advances. Beyond providing entertainment for the audience, with also coincides with the celebration that accompanies twelfth night. Often as part of the celebration,

both long ago as well as during the 16 hundreds the theme or role reversal has accompanied the twelfth night of Christmas. Men and woman cross dressing as a way to both relieve any tensions between them as well as to insight merriment. The themes of identity that are portrayed on the stage should be extended beyond the walls of the theatre.

In order to make the performance even more of an all-encompassing experience it is important to interact with the audience beyond the stage. Upon entering and purchasing their tickets an audience member would receive a Venetian Mask, which they would be encouraged to wear for the remainder of the evening. This is done to try and give an air of discovery as well as to give the audience the feeling that their own identity has been hidden, allowing them to both enjoy the performance while being able to relate to Viola. Furthermore, it will make them whiling participants as parts of the festival.



Figure 27: Venetian Mask, Several designs of this type would be used.

The experience continues again through the house design as well as through concessions. While the play is called *Twelfth Night*, it was not actually performed on the twelfth night of Christmas. Instead the first performance took place on February 2, 1602. February 2nd is known as being the Festival of

Candlemas which celebrates the Presentation of Jesus at the Temple. Being one of the twelve Great Feasts, it was a time of great celebration and merriment. Instead of the normal cookies and desserts that normally are offered, an array of succulent food would be prepared. Slices of roasted chicken, Beef Wellington and Carrots with honey and dill would be prepared as well as crepes and cakes. Mulled Wine, Cider, and Beer would be added to the normal drink fare and a longer intermission would be required in order for people to consume their dinner and enjoy the entertainment provided.

To ensure that the audience doesn't lose interest, the house design needs to be a form of entertainment within itself. While it is important to have a professional looking staff, in order to help create the experience, the ushers would wear similar venetian masks, made slightly more intricate in order to distinguish them from the rest as well as their normal dress blacks. This keeps them within the world of the play while also distinguishing them enough to have audience members find them if they need assistance. In addition to the ushers, musicians would be brought in to play in the house. Performing up beat jovial songs like those of the traditional masquerades. An open dance area would allow audience members to dance or simply admire several professional dancers. Several jesters would also be sprinkled throughout house to provide entertainment. The jesters would perform such acts as acrobatics, juggling, and stilt walking. In order to further their legitimacy, the jesters, dancers, and musicians would all be dressed in the Masquerade style.



Figure 28: Possible Costume for the Featured Dancers



Figure 29: Possible Costume for Male

Decoration of house as well as the theatre should be made to match that of a festival. Two long wooden tables would replace the black table cloths and round tables in order to promote conversation as well as to inspire the idea that it is an old dining hall. Brightly coloured fabric would be draped across the ceiling from one chandelier to the next, as well as coating the walls. A thin veil would separate the door ways, and the bathrooms and tables would be mostly candle lit. Even the fire places would be in full effect. Overall the effect should be welcoming and homely.

As for the Theatre itself, the set and decorations should inspire the feeling that the Little Theatre is the personification of the Globe Theatre. The Little Globe Theatre would be represented through a total change in overall facing. The walls of the theatre should be covered to match the white walls with wooden beams that is iconic of the globe. The grid would be disguised so that it appears to be entirely wooden and the I-beams would become thick wooden beams. A short railing would separate the audience from the play space as if they held the more expensive balcony seats. Finally the stage itself would be true to the globe stage. A short raised section would take up most of the theatre, acting as the stage. At the back would be a wooden wall with several doors to act as entrances and exits, and set above those would be the balcony with an exit toward one end and ladder hidden behind it. The moment the audience leaves the dancers and jesters, they should feel transported as if being sent back to the days when Shakespeare still wrote.



Figure 30: The New Globe Theatre

Costume and Props Project EN2222

Father:

- Age: 47
- Is in good health thanks to the fact that he takes good care of himself
- Large and well built
- Smokes cigars
- Carries himself with power
- Italian
- Well educated
- Street smart
- Very opinionated
- Appreciates money
- Strong Willed
- Not afraid of fighting
- Protective
- Clean
- Will hold to his morals but his morals are not entirely pure
- Extrovert
- Businessman

This is a man who carries himself tall and proud, and will argue for his beliefs in a moment. He understands that in order to be powerful and successful, that he has to dress powerful and successful. His fully matched well groomed well known three piece suit is his suit of armor as he goes into his own personal battle to make money, and to show off his skills. His watch also contributes to flaunting his wealth and power. For his bed attire, he retains the prestige that he always carries, with a classy expensive robe monogrammed with his name and family crest. Plus a pair of warm expensive slippers. Finally as he keeps himself in good shape, but still wants to look dignified, he wears a matching three piece track suit.

Architect:

- Age: 31
- In fine health, nothing exceptional
- Lean but muscular

- Confident but not arrogant
- Grew up catholic, but doesn't go to church regularly
- Educated
- Slightly Naïve
- Hard worker
- Motivated

The architect wears nice wire frame glasses which show off his professionalism without compromising his youth. This trend continues with the blue collared shirt, professional but the rolled up sleeves renew the youth that he still has. The khakis and brown shoes, continue his professionalism, without being super formal. His bed attire is simple, with a white shirt and boxers. He doesn't over think the cloths he wears to bed because they aren't important. He has a similar reaction to working out. It's simply done to keep himself fit, and not to show off at all, so the nonchalant gym shorts and white t shirt make sense.

Physiatrist:

- Age: 45
- In good health
- Slightly gaining a gut
- Calm
- Highly educated
- Sense of Humor
- Very professional
- Not money oriented
- Loves his family
- Does good work, but none more than is expected from him.

The Psychiatrist is similar to the architect but is a more aged version, and has a more academic personality. This is where the horn rim glasses and leather watch are important. They show off the professionalism of the psychiatrist but don't flaunt money or ego. They are subtle reminders that the psychiatrist is well off and enjoys his comforts, without being showy. His professional work attire consists of a blue collared shirt, blue patterned tie, argyle sweater vest, darker khakis and penny loafers. These show off that he is warm and accepting to his patients, while also making him a voice of reason and making the advice he gives, valid and relevant to his patients. His sleep attire shows off his sense of humor more: wearing a checkered robe,

humor boxers, often involving smiley faces, and moccasin slippers. His workout cloths involve a white t shirt, running shoes, and gym shorts with his colleges logo on them. Showing the casual nature, but also reminding him of his college years and the academia that he's involved in.

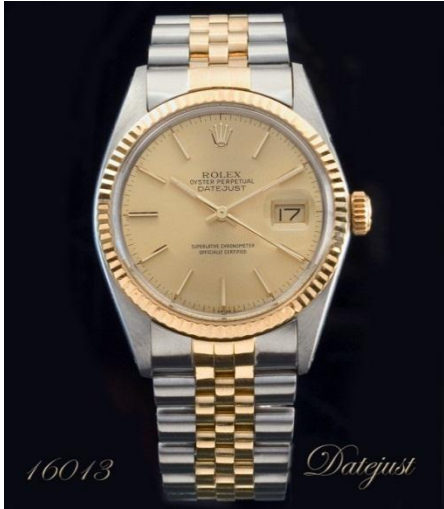

FATHER
Watch(ALL)
Business 3 piece Suit
(Work)



Robe and Slippers (Relax/Bed cloths)



2 Piece track suit(Work Out)
Running Shoes(Work Out)

Architect

Wire frame glasses (All)



Collared Shirt (rolled up sleeves)(Work)



Brown Shoes and Khakis (Work)



White Shirt and blue striped boxers (sleep)



White Shirt, Nike Running Shoes, and gym shorts (work out)



Psychiatrist

Horn Rim Glasses (all)
Leather strapped Watch(all)



Blue Collared Shirt(work)
Argyle Sweater Vest(work)
Dark Khakis(Work)
Blue Pattered Tie(Work)





Brown Penny Loafers (work)



Checkeded Robe (Sleep)
Moccasins Slippers(Sleep)
Humorous Boxers(Sleep)



White Shirt (work out)
College Gym Shorts (Work Out)
Adidas Running Shoes (Work Out)



SOUND MINI-PROJECT

- Radio Tune
 - The Tuning was only altered in that it was faded out at the end.
- Wind
 - Wind was reversed and normalized, as well as noise reduced to get rid of unnecessary white noise. A fade in was added
- Cotton Flapping
 - Was also noise reduced.
- Phone Ring
 - Each ring was edited so that the volume would increase with each ring.
- Clock Tick
 - Looped several times.
- Scream
 - Clip was slowed down and the pitch was raised.
- Fire Alarm
 - Volume level decreased throughout the effect as well as a fade in was added.
- Laughter
 - Slight fade in added.
- Gasping
 - Clip was trimmed down, and slight increase in volume.
- Car Engine
 - Fades were added to smoothen out the effect
- Hospital
 - Normalized and noise reduced along with fades in and out.

The individual design process had a different set of challenges associated with it as opposed to the working with a group. The authors suggestion that the moment should be ludicrous in manner allowed for a lot of freedom in designing how the scene should be shaped. This lead me to add sound I felt were appropriate for the moment even though they were not mentioned in the script explicitly. Sounds like the laughter and clock ticking added a more sinister flair in the process. While finding new sounds to add in, was interesting and amusing, it was disappointing when certain sound effects just

couldn't be found even using the resource provided. In particular, I could not find a sound effect for a flag, nor that of a screen door flapping around. Moreover, of the sounds I used I felt certain effects were not as perfect sounding as I would like. The car engine specifically was difficult to track down an engine that sounded like a car at full speed, which is why the effect is less prominent in the track. Overall however the greatest challenge to overcome was that of designing knowing that the effects need to transition into other sounds. When I designed the first part, it very much had a beginning middle and end to the effect, which would sound weird if it then transitioned into two more sets of sound. As such, I reworked the end of my portion to have a more open end to it which could be expanded upon.

The group portion of the project presented a different set of challenges; mainly, because each person has different visions for how the moment should be portrayed and what manner should the moment come across in. While I had a multi-leveled track for my portion, other group members focused more on each sound at a time, allowing for transition between the effects as opposed to the effects happening simultaneously. This led to a difficult transition between the different styles. Often leading to a more simple transition between the groups, (i.e. cross fades and specific follow time), which is harder to mask than if stylistically they were similar, and could have had more overlap. The way the moment is set up, there wasn't a good way to try and establish a common thread when three separate people are designing. The easiest part of the group portion was actually getting the three parts together into one track, which only took a few minutes, which in comparison to the time it took to create our individual parts, was relieving.

Lighting Mini-Project

The moment which my plot is designed for is from the play, *A Shot In the Dark*, when the two ladies leave their apartment and travel to the apartment across the way, where they believe the gun shot has occurred. As the ladies leave their apartment, the overhead lighting for apartment one goes dim, to an almost black. This allows for a clear distinction between the apartment and the hallway that they are entering. This is also the first time that lights come up on the hallway showing that the world of the play is now growing in size. As the overhead lighting for apartment one goes dim, Seladors one and two transition from a bright yellow-orange to a half intensity blue. Selador three should then come up with the overhead hall lights with slightly more than half intensity, at a purple-blue color. The Seladors help to change the mood, from a light cheerful apartment to the mystery that the ladies are seeking. As the ladies enter apartment two, Seladors one, two remain the same, while Selador 3 keeps its color, but dims to the level of Seladors one and two. This helps show the transition to apartment two, while simultaneously removing focus from that portion of the stage. The overhead hall lights would also come down to the dimness of apartment one overheads.

The apartment two lighting is designed to have a creepy, mysterious feel for it. The main sources of light come from the three Ellipsoidals. Ellipsoidals one and three, use blue gels to create that cool feeling that the scene dictates, as well as coming from almost side angles to get some interesting shadows on the actors. The blue feel, also greatly contrasts apartment two from apartment one, which is much brighter and more cheery. They are focused so that their light is limited to the platforms so that a distinction can be made between the platforms and the floor.

Ellipsoids one and three, are kept at a medium intensity so that the actors can be seen, but to show that this is not a bright area. Ellipsoidal two uses a warmer amber color to allow for slightly more definition on the faces of actors, however is kept at a much lower intensity to allow the blue feel to be the main source of light, and maintain the blue wash. To add to the mystery of the apartment, Selador 4 should come up to 3/4th intensity purple; adding to the somber that the blue creates but adding in a little bit more of the mystery of the scene. There are also two Fresnels being used for two effects. Fresnel one is designed to come up with rest of the apartment two lights and remains at mid-range intensity. Its use is to light the ladies while they hide, in this case behind the set but with their heads protruding. The back lighting for while they hide will give them a shadowy look that conveys that fact that they are hiding. Finally Fresnel two is used as god light, pointing straight down. Its purpose is to highlight the blood in the room. By separating the blood from the rest of the lighting creates a stark distinction between them, and allows both the women and the blood to be highlighted. Both Fresnels would be used with a warm gel similar to Ellipsoidal two. Finally as the scene ends and the ladies progress back to their apartment all the lights in the hallway and apartment two come down, to show that the world is shrinking back into their apartment. Their apartment would return to its warm, homely nature.

The lighting adds to the mystery and intensity of the scene while not detracting from the scene itself. It allows for the clear distinction of areas and highlights the important aspects of the scenes. The gradient that Seladors create shows the separation of area, as well as mood throughout the play well.



R 02 Bastard Amber, Used for Fresnels and E2



R 74 Night Blue, Used for E2 and E3



F1 creates this type of effect for the two ladies while they are hiding.



Similar colors and lighting angles for apartment 2. Slightly more warmth coming from the front.