



# Monitoring Electricity Consumption on the WPI Campus

The Reduction of Carbon Emissions through the Implementation  
of Energy Information Tracking Technology

Submitted by:

Christopher O'Hara  
Maximillian Hobson-Dupont  
Max Hurgin  
Valerie Thierry

Submitted to:

Project Advisors:

Prof. Scott Jiusto  
Prof. Fabio Carrera

**May 5, 2007**

## Executive Summary

Worcester Polytechnic Institute, as a community of over 4,000 students, faculty and staff, is a significant consumer of electricity. The problems associated with trying to provide electrical power to a large community are considerable indirect carbon emissions, sizeable, and ever-increasing, utility bills, as well as the cost and effort of maintaining a complex distribution infrastructure. As energy prices continue to rise and global warming becomes a very important concern, heavy electricity consumers such as WPI have a responsibility, as well as an intrinsic motivation, to reduce their electricity consumption and attendant costs.

It is clear that WPI is making efforts to reduce its impact on the environment. The new residence hall presently being constructed is aimed to achieve LEED silver certification, a step above basic LEED certification which certifies a certain level of environmental sustainability. There is, however, much room to improve the environmental impact of the already present buildings. WPI is a leading technical institution, and as such, should serve as an example for integrating technology with environmental responsibility by tracking its electricity use. There is no single point-source for information on WPI's present electricity metering system and there is ambiguity among the administration about which meters are working, what they're recording, and for what buildings they providing data for. Also, there has been no analysis of electricity usage data to observe any emerging trends. If steps are to be taken to improve the energy monitoring system at WPI, there is no information on where to start from.

Our project's mission is to evaluate, analyze and improve the electricity data collection system on the WPI campus. To achieve these objectives we first compiled a campus meter inventory evaluating the present energy monitoring capabilities of each building. We also collected what data we can from the meters. Not only did this give us insights into the data collection process, but we also analyzed the data to identify trends in electricity usage. Additional research is presented in different electricity monitoring systems. Using the information that we have gathered and what we have concluded, we have presented a plan to improve the system. Such improvements will allow WPI to accurately track its electricity consumption and identify unnecessary electricity use.

The data we collected came from two primary sources, our reading and recording of the information from the electricity meters, and the usage and expenditure data included in the electricity bills. The data from the electricity meters was woefully incomplete; in total, we were able to read different sub meters around the campus on four different occasions. We visited every academic building that had meters at least two different times, in order to determine how much energy was used over a known time period. It would've been possible to generate more complete usage profiles for the buildings with working meters, however the fact that walking from building to building reading the meters presented a large time commitment, leading to scheduling issues which prevented us from reading the meters as often as we would have liked.

### Average Energy Usage Per Day of WPI's Main Campus (Mwh/day)

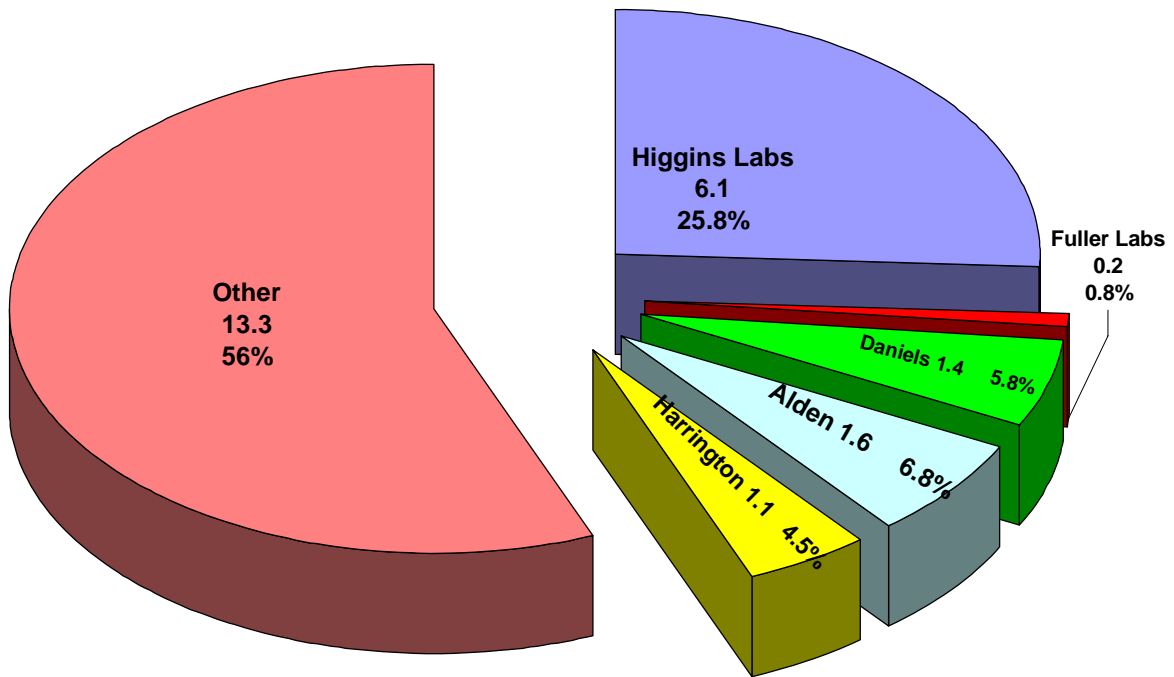

After extensive research, the conclusion was reached that there are three main options for improvement. The first possibility is to do an overhaul of the meters, replacing all of them – working and non-working – with new devices, all of the same make and model. The other two options are similar in that they are both data logging systems, yet differ in the capabilities of the data loggers themselves.

In our opinion the most effective option is the ElitePro data logger. Manufactured by DENT Instruments, the ElitePro is \$1200 plus an additional \$200 for the current transformers and \$150 for the ELOG software, which is used to graph and analyze trends and patterns in the data (DENT). Installation cost is negligible because the product requires no functioning meters in order to collect and transmit data, and the installation process of the logger itself is basic enough to be done by an electrician here at WPI.

The ElitePro can be configured to take readings from as frequently as once per second to as infrequently as once per every 24 hours (DENT). For our purposes, hourly readings would be best, and we would be able to database and graph the collected readings. This information could be uploaded to a website that is linked to the main WPI site, so the electricity consumption data would be accessible to anyone who visits the school's page. These real-time graphs would serve as an invaluable resource in analysis as well as in tracking problems and improvements, enabling WPI to check the accuracy of utility billing, track for power interruptions as well as verify electrical savings of lighting upgrades (when WPI makes such upgrades) – capabilities which will ensure reduced waste and streamlined operations.

There would be no need to phase in this system, as it does not require functional meters. Thus, replacement of our existing meters is not an issue and the fact that the ElitePro can take readings directly from the electrical system is an advantage because meters, even state-of-the-art

digital ones like the Wattnode Plus, will quickly become obsolete and are inefficient ways of collecting data.

An important consideration in determining the wisdom of implementing a system is the payback period. Given an estimate of roughly \$25,000 to update the main campus (equipment plus software plus installation costs) with the ElitePro data logging system and its software, the payback period can be relatively short with even modest improvements in energy consumption. If the system yields a reduction of peak energy usage by 1%, the energy-related savings would be roughly \$15,000 per year (using \$0.08 per peak kilowatt-hour) at the school's current rate of energy usage. Reducing the peak demand by 1% could save up to an additional \$16,000 (est.), based on an average campus peak demand of 1.8 MW. The total estimated savings for this 1% reduction is around \$30,000, which is more than the estimated upgrade cost. Gustavus Adolphus College cited a 6% reduction in peak energy use (Gustavus Adolphus, 2006), which shows that there are attainable levels of improvement which could keep the payback period well within a year, a very reasonable estimate. In addition, if the system is maintained and used for several years, with rising energy prices, the system could potentially yield significant savings, depending on its level of effectiveness. Certainly the initial investment required is justified by the possible savings in the future.

Initially, the 6 dorms (Morgan Hall, Riley Hall, Daniels Hall and Stoddard A, B and C) should be outfitted with data loggers, one per building. The Ellsworth and Fuller apartments were omitted from consideration due to their slated demolition and the fact that each individual apartment is already separately metered, which would make the cost prohibitive, potentially adding over \$60,000. The cost of the 6 loggers (and the necessary current transformers for each logger) is \$8100. The accompanying ELOG software, used to analyze the collected data, is a one-time purchase that costs \$150 for the entire package. Installation cost is minimal, as the system can be set up by either Plant Services or engineering students. Therefore, the entire cost of the proposed short-term implementation of the system is approximately \$8,250, plus taxes and shipping charges.

Once in place in the 6 dorms, the system can be tweaked as students and administration work out the bugs and start to effectively make use of the capabilities of this technology. If the applications of the data logging system are as effective as expected, the second part of the implementation will be to install 10 additional loggers in the academic buildings (Higgins Laboratories, Campus Center, Kaven Hall, Alden Hall, Atwater Kent, Fuller Laboratories, the George C. Gordon Library, Olin Hall, Salisbury Laboratories and Washburn Shops). This division of the project is estimated to cost \$13,500 (10 loggers and the necessary current transformers). At the conclusion of this phase, nearly the entire campus will be outfitted with data loggers and information from a total of 16 buildings will be readily available online, at a total cost of approximately \$21,750.

\$22,000 is just a fraction of the amount of money that WPI spends on electricity yearly (roughly 1%). Using the feedback provided by the new system, electricity consumption can be significantly reduced. Even small percentage-wise cutbacks in usage will yield dramatic savings on electricity bills. When students, faculty and administration are provided with a visual representation of usage data, they can then modify their behaviors and attitudes in order to reduce their consumption. People, when supplied with feedback, are much more likely to exhibit the desired behavior than those that do not have feedback. As humans, we feel the need to know that our behaviors (and any changes we make in them) have a purpose. Given these expected

savings and educational opportunities, it is clear that implementing such a system will greatly benefit WPI now and in years to come.

The implementation of a system like this provides ample educational opportunities in the form of subsequent Interactive Qualifying Projects (IQPs) and even Major Qualifying Projects (MQPs). Successive IQPs would be able to continue to improve upon the new monitoring system, as there will most likely be program glitches and further small technical problems to work through. Even once the actual improvement stage is complete, IQP teams will have countless other project opportunities to take on because the environmental, economical and social applications of this system are limitless.

The MQP opportunities provided by the data logging project would be far more specific. For example, the networking aspects of the system are appropriate for a computer science project and electrical facets would be apropos for electrical engineering projects. Since these projects are more in depth and major-specific than IQPs, the number of MQPs available would be significantly less, but the educational possibilities are still viable.

## **Abstract**

This report, prepared for the Plant Services Department at Worcester Polytechnic Institute, evaluates the present status of WPI's electricity monitoring system, on a building-by-building basis. It includes a comprehensive report of the electricity meter functionality for several dormitories and academic buildings. Also, it presents a short and long-term plan to improve the school's ability to monitor its electricity consumption.

## Acknowledgements

This team would like thank to the following individuals for their contributions to our project:

Richard “Dickie” MacNulty

Chris Salter

Francis Horanzy

Liz Tousignant

John Miller

John Orr

Richard Vaz

Megan Weeks at DENT Instruments

Mike Kasmarik

## Table of Contents

Executive Summary .....	ii
Abstract .....	vi
Acknowledgements .....	vii
Chapter 1: Introduction .....	11
Chapter 2: Background .....	13
2.1: The Emerging Global Warming Problem .....	13
2.1.1: What is Global Warming? .....	13
2.1.2: The Dangers of Global Warming .....	14
2.1.3: Solutions to the Global Warming Problem .....	14
2.1.4: Energy Costs .....	15
2.2: Electricity Consumption and Efficiency .....	16
2.2.1: Electricity Consumption and Carbon Emissions .....	16
2.2.2: How Electricity is Wasted .....	16
2.2.3: How to Make Consumption More Efficient .....	17
2.2.4: Understanding Energy Usage .....	18
2.3 WPI's Electricity Usage and Expenditure .....	18
2.4 Monitoring Electricity Consumption .....	19
2.4.1: Scope of monitoring .....	19
2.4.2: Dimensions of measurement .....	20
2.5: Case Studies and Examples .....	23
2.5.1: Gustavus Adolphus College .....	23
2.5.2: Oberlin College .....	24
Chapter 3: Methodology .....	26
3.1: Evolution of the Project .....	26
3.2: Electricity Bills .....	27
3.3: Data Collection Process .....	27
3.4: Electricity Meter Inventory .....	28
3.5: Data Collection and Visual Representation .....	31
3.5.1 Various Modes of Data .....	31
3.5.2 Types of Visual Representation .....	32
3.5.3: Use of Visualizations .....	33
Chapter 4: Results and Analysis .....	35
4.1 Electricity Bill Analysis .....	35
4.1.1: Cost Breakdown .....	35
4.1.2: Consumption Trends .....	36
4.2: Electricity Data Analysis .....	37
4.2.1: Breakdown of Campus Energy Use .....	37
4.2.2 Fuller Apartments .....	38
4.2.3 Peak Power Usage on WPI Campus .....	40
4.3: Electricity Meter Status Report Analysis .....	41
4.3.1: Total Energy Usage Meter Monitoring Analysis .....	41
4.3.2: Instantaneous Power Usage Monitoring Analysis .....	42



4.3.3: Maximum Power Usage and Other Monitoring Analyses.....	43
Chapter 5: Conclusions and Recommendations .....	47
5.1.1: Electricity Bills .....	47
5.1.2: Building Electricity Use.....	47
5.1.3: Meter Status Report .....	47
5.2: Improvement Options .....	43
5.2.1: Meter Replacement .....	43
5.2.2: Echelon e3 100 Data Logger .....	44
5.2.3: ElitePro Data Logger .....	45
5.2.4: Final Recommendations .....	48
5.3: Expected Results.....	49
5.3.1: Eventual Savings.....	49
5.3.2: Project Opportunities .....	50
Chapter 6: Works Cited .....	51
Appendix A: WPI's Electricity Bills (6/15/05-10/26/06).....	54
A.1: WPI's Monthly Electricity Bill, Page 1 .....	54
A.1.1: WPI's Monthly Electricity Bill, Page1, Section 1 .....	55
A.1.2: WPI's Monthly Electricity Bill, Payment information .....	55
A.1.3: WPI's Monthly Electricity Bill, Page 1, Section 3 .....	56
A.1.4 Electricity Bill, page 1, section 3 .....	57
A.2: WPI's Monthly Electricity Bill, page 2 .....	58
A.2.1: Electricity Bill, page 2, section 1 .....	59
Appendix B: Average Energy Usage Per Day of WPI's Main Campus .....	60
Appendix C: Fuller Apartments Energy Usage .....	61
Appendix D: Ellsworth Apartments Energy Usage .....	62
Appendix E: Map of WPI's Main Campus.....	63
Appendix F: Meter Status Report .....	64
F.1 Electricity Meter Evaluation Legend.....	64
F.2: Electricity Meter Inventory .....	65
F.3: Meter Capabilities.....	87
F.4: Energy Meter Data Quality.....	88
F.5: Meter Functionality .....	89
Appendix G: WPI's Electrical Distribution Chart.....	90

## Table of Figures

Figure 1: Digital Power Meter in Alden Hall .....	21
Figure 2: Meter inventory cover page.....	28
Figure 3: Example of meter status report (see Appendix F.2 for details).....	30
Figure 4: Campus map showing meter locations and functionality.....	33
Figure 5: Electricity Bill Breakdown (% of total cost).....	35
Figure 6: WPI's approximate monthly electricity consumption .....	36
Figure 7: WPI's Total Energy Usage Mwh/day (12/7/06-3/22/07).....	38
Figure 8: Total Energy Usage for Ellsworth Apartments (2/13/07-3/22/07).....	39
Figure 9: Total Energy Usage for Fuller Apartments (2/13/07-3/22/07).....	40
Figure 10: WPI's Peak Power Usage (12/7/06-3/22/07).....	41
Figure 11: Salisbury Labs Meter (no multiplier displayed).....	42
Figure 12: Olin Hall's meter (needle is off the scale) .....	42
Figure 13: Advanced Digital meter for Alden and Riley Hall's.....	43
Figure 14: Wattnode Plus Power Meter.....	44
Figure 15: The Echelon e3 100 Data Logger.....	45
Figure 16: The ElitePro Data Logger.....	46
Figure 17: Improvement Option Comparison Matrix.....	49
Figure 18: An example of succesful energy monitoring in a dorm at Gustavus Adolphus .....	50

## Chapter 1: Introduction

As the issue of global warming moves steadily towards the forefront of public awareness, so does the very real problem of excessive energy use and its impact on the environment. Global warming is related to carbon emissions, and carbon (along with other greenhouse gases) is what is released when energy is consumed. It follows accordingly that increased energy use leads to increased levels of greenhouse gases in the atmosphere, contributing heavily to global warming. The logical first step in reducing humankind's effect on the environment is to lessen or cease the actions that are directly impacting it. This all-encompassing step can be termed 'energy conservation' and in the broad spectrum of myriad different ways to conserve energy, cutting back on electricity is one of the most powerful and effective means to go about it. Faced with a problem so daunting, many private homes and corporations alike may feel that even if they were to take the initiative to make their lives 'greener', it would be in vain. However, no effort to cut down on your carbon footprint is in vain – every ton of CO<sub>2</sub> that is not released into the atmosphere is a step in the right direction. To begin the process of cutting back on everyday energy use (and consequently, your carbon emissions), it is first critical that you identify the areas that will yield the most savings upon reduction.

Companies and organizations everywhere are taking a closer look at their electricity consumption because they realize that in order to make improvements to existing systems, it is necessary to have an accurate sense of where the problems lie. It is impossible to fix what is unknown and even more challenging to fully understand something you can't measure. This is the root of electricity monitoring. Data loggers allow electrical consumption to be measured, recorded and analyzed with ease and once this data is collected and profiled, it is possible to scrutinize usage trends and most importantly to identify the areas where cutbacks would be most beneficial. More efficient and specific monitoring leads to better data analysis, which is followed in turn by more effective efforts at electricity reduction. Colleges and universities are excellent targets for reduction efforts and usage improvements – with high-tech classrooms, laboratories, dining halls and dorms, campuses use huge amounts of electricity and much of it (especially in residence halls) is unnecessary use. Considering that college students are, as a general age group, some of the most environmentally conscious people, a campus is a logical location to make environmentally conscious improvements.

WPI is clearly taking steps towards a "greener" campus, as evidenced by the construction of new buildings. Its newest building, The Bartlett Center, is registered with the U. S. Green Building Council, and uses innovative architectural methods to reduce the load on its lighting and air-conditioning systems. Other educational institutions have explored energy monitoring systems and are reaping the benefits. Using electricity usage monitoring systems provided by Puget Sound Energy, The Issaquah School District in Washington State was able to identify a grossly unnecessary misuse of electricity and correct it. This resulted in a monthly savings of \$3400. Last year WPI used approximately 22,000,000 kilowatt-hours of electricity. This is equivalent to the energy content of nearly 9000 tons of coal! With so much energy being consumed, it is important to understand how that energy is being used.

It is clear that WPI is making efforts to reduce its impact on the environment. The new residence hall presently being constructed is aimed to achieve LEED silver certification, a step above basic LEED certification which certifies a certain level of environmental sustainability. There is, however, much room to improve the environmental impact of the already present buildings. WPI is a leading technical institution, and as such, should serve as an example for integrating technology with environmental responsibility by tracking its electricity use. There is no single point-source for information on WPI's present electricity metering system and there is ambiguity among the administration about which meters are working, what they're recording, and for what buildings they providing data for. Also, there has been no analysis of electricity usage data to observe any emerging trends. If steps are to be taken to improve the energy monitoring system at WPI, there is no information on where to start from.

Our project's mission is to reduce carbon emissions by evaluating and analyzing the electricity data collection system on the WPI campus. To achieve these objectives we first compiled a campus meter inventory- evaluating the present energy monitoring capabilities of each building. We also collected what data we can from the meters. Not only did this give us insights into the data collection process, but we also analyzed the data to identify trends in electricity usage. Additional research is presented in different electricity monitoring systems. Using the information that we have gathered and what we have concluded, we have presented a plan to improve the system. Such improvements will allow WPI to accurately track its electricity consumption and identify unnecessary electricity use.

## **Chapter 2: Background**

Global warming is quickly becoming the most important issue in environmental politics, and is the most dangerous ecological problem in today's world. Global warming is just that: global; it affects all nations and peoples, and it is important that we all work towards the solution now, as the problem will only get worse. One of largest contributors of carbon emissions is electricity production. As a leading technical institution, WPI needs to set an example by reducing its carbon emissions by curtailing its electricity usage. The simplest way to cut down on these emissions is to use less electricity; however this is more easily said than done. It is necessary to understand how electricity is produced, transported and used in order to reduce the amount of harmful carbon emissions that this system produces. It is also necessary to accurately measure electricity consumption to optimize energy usage. This section will investigate electricity production methods and how they contribute to direct carbon emissions. It will compare mainstream production methods with newer, more environmentally friendly methods, and the economics behind both options. Lastly, we will focus on measuring and recording WPI's electricity consumption, and viable ways as to how this data can make WPI's energy consumption more efficient, thus reducing carbon emissions.

### ***2.1: The Emerging Global Warming Problem***

The premier issue facing the world's environment today is global warming. This is the increase in the average temperature of the earth's surface, and the climate-changing consequences (Clean Air-Cool Planet, 2006). The question that we have to face is whether or not we want to ignore these ecological problems or if we want to make proactive changes to clean our environment. The majority of the scientific community believes that global warming is mainly caused by the emissions of greenhouse gasses through the combustion of fossil fuels (Clean Air-Cool Planet, 2006). This condition can be reduced by increasing the amount of greenhouse gas absorbers, known as sinks, and/or by reducing the amount of greenhouse gas emissions.

#### **2.1.1: What is Global Warming?**

Briefly, 'global warming' is the continued increase in the earth's atmospheric temperature as a direct "result of energy from the sun being trapped by gases in the atmosphere" (Clean Air Cool Planet, 2006). Much of the energy produced by human means is done so in the burning of naturally occurring organic compounds such as coal and oil, known as fossil fuels. While the burning of this type of material releases a significant amount of energy that can be put to various practical uses, it also emits a very large quantity of carbon dioxide (CO<sub>2</sub>).

CO<sub>2</sub> is one of the gases in the group commonly referred to as "green house gases" (or GHGs) that insulate Earth by acting as a barrier to prevent the re-entry of heat energy into the atmosphere and therefore is a gas necessary to the continuation of life. It is present on Earth as a byproduct of natural processes like respiration, but in excess is extremely detrimental to the environment. A surplus of this and other GHGs in the

atmosphere contribute to a larger percentage of trapped energy, leading to increased temperatures on Earth. In addition to carbon dioxide, the term “GHG” refers to methane, ozone, nitrous oxide and hydrofluorocarbons (HFCs), among others.

### **2.1.2: The Dangers of Global Warming**

At first glance, an increase of temperature by 2 to 3 degrees Celsius over the past 50-55 years appears to be of no consequence (Pimentel, 1994). However, upon consideration of the effects already being experienced as a result of rising temperatures, it is apparent that a seemingly negligible increase contributes significantly to rising ocean levels and warmer winters as well as having an impact on the health of all kinds of organisms – humans included.

Seacoast towns and cities are deeply affected by any rise in sea level, no matter how small. Industries and businesses, in addition to homes, roads, and docks, all suffer. In the Arctic, an area where temperatures are rising at approximately double the average global rate, a number of communities on the coast have already been considering relocation as a consequence of impending flooding (Clean Air Cool Planet, 2006).

In addition to damaging property, real estate values and recreational areas, rising sea levels due to glacial melting also threaten the environments of many arctic animals. Higher global temperatures causes an increase in melting which unquestionably leads to an altered habitat for polar bears, penguins and various other animals, threatening their food sources and transportation. Organisms that thrive along the coasts are not the only animals distressed by global warming – over 50% of the wild animals in the U.S. are estimated to have already been affected by climate change thus far (Clean Air Cool Planet, 2006).

Many plants are very sensitive to temperature and shorter, warmer winters as well as longer, hotter summers are both injurious to these vulnerable organisms. Alterations in seasonal climate patterns disrupt flowering and reproduction and make it necessary for plants to shift their ranges in order to survive on a planet with ever-increasing temperatures (Clean Air Cool Planet, 2006).

The burning of fossil fuels not only harms plants and animals – humans are directly affected as well, and in more ways than one. An increased number of pollutants in the atmosphere are believed to be a leading cause of asthma. A Children’s Health Study at the University of Southern California found that kids who live in communities with a higher level of ozone (a GHG) are more likely to develop asthma than children who live in areas with lower ozone concentrations (Myhr, 1998).

### **2.1.3: Solutions to the Global Warming Problem**

There is no single straightforward solution to the global warming crisis. Instead, there are a variety of actions that can be taken to reduce the amount of green house gases emitted into the atmosphere. Some efforts towards GHG reduction will naturally be more effective than others, but even simple steps to cut back emissions will help in the slowing of global warming. However, the first stride in this undertaking is that of understanding. In order to solve the problem, those who are causing it must first grasp the issue and

realize the cause-and-effect situation that we as humans are a part of. Once a problem is realized, it is possible to begin the task of formulating a plan to solve it.

Careless use of energy is a large part of the global warming problem. Obviously it is impossible to totally eliminate GHG emissions, but it is undoubtedly in our power to reduce them. Energy-efficient cars like the Toyota Prius are on the market as well as on the streets, and better gas mileage means less gas burned and fewer GHG emissions. For every gallon of gasoline burned, 8.64 kilograms of CO<sub>2</sub> is emitted. (DOE, 2002) Development of cleaner energy sources like ethanol in place of gasoline for automotive fuel and wind power instead of fossil fuels is a top priority in efforts to clean up the environment and cut back the amount of gases released into the air.

Trees consume a huge amount of CO<sub>2</sub> in the process of aerobic respiration – 10 billion acres of trees is able to consume approximately 1 trillion tons of carbon and convert it to oxygen and water in the natural process of respiration. (DOE, 2002)

However, we can reduce our carbon footprints by even simpler methods, without altering our energy sources at all. Merely by considering our energy usage and conserving where we see fit, we can significantly lessen our damaging effects on the environment. Examples of nearly effortless (but highly important) possible actions at conservation include just turning off lights when no one is in the room and shutting off a computer monitor when the machine is not in use. These measures, though seemingly trivial, literally prevent tons of carbon from being emitted into the atmosphere each year.

#### **2.1.4: Energy Costs**

With energy costs on the rise it is becoming more and more important to understand how energy is used and how it is being wasted. The first step here is to understand why energy costs are rising so that steps can be implemented to try and reduce this cost. Decrease in supply, political instability, and natural disasters are some of the short term reasons why energy costs have been increasing. While some of these are out of the control of the average person there is one way to reduce energy needs that just about anyone can do, that is to increase the efficiency of the energy used. With 5% of the world's population the United States uses 25% of the total oil world wide and 40% of the world's gasoline. This statistic shows that the United States as a whole is not being very efficient with its energy.

As the world develops industrializing third world countries will ever be increasing their energy usage. This will lead to a dramatic increase in carbon emissions world wide, which will only increase the global warming problem. While this growth is inevitable the habit of wasting energy in order to grow technologically needs to stop. There are many ways to do this but one of the best is to lead by example. By increasing the efficiency of energy production and use, the United States can reduce their demand and therefore reduce the cost of energy world wide.

## **2.2: Electricity Consumption and Efficiency**

Understanding electricity consumption is a key element in reducing real carbon emissions. There are many different uses and applications for electricity, with varying amounts of required power. Any application that uses more electricity than it requires is wasting electricity. It is important to identify, study, and optimize these inefficient electrical applications. To find these “trouble spots” it is necessary to accurately measure and record data on electricity consumption. This is what we hope to do at WPI. Through reading electricity meters and cataloging data, we can identify these trouble spots and make recommendations for improvement based on the specific application. This not only economically prudent but is environmentally responsible, resulting in lower real carbon emissions.

### **2.2.1: Electricity Consumption and Carbon Emissions**

In 1998, approximately 40.5% of the carbon emissions in the United States can be attributed to the burning of fossil fuels in generating electricity (DOE, 2002). Different areas of the country employ varying methods of electricity generation, ranging from wind power to nuclear power to the somewhat old-fashioned combustion of fossil fuels. Regardless of how it is produced, production is based on consumption, with the former increasing alongside the demand of the latter. As long as consumption stays high, production will too and it is essentially the production of electricity that has such harmful effects on the environment.

Coal-fueled generators have been found to produce the most CO<sub>2</sub> per kilowatt hour, making coal an especially environmentally detrimental source of energy - about 80% of the carbon produced in electricity generation is attributed to coal burning. The other 20% is due to generation from sources like petroleum, natural gas and nonfossil fuel methods (DOE, 2002).

Under the Clean Air Acts implemented in the 1990's, companies are required to comply with rules limiting the amount of GHG emissions. Many plants and various companies have also made investments in newer and more efficient technology that emits less carbon while maintaining an acceptable rate of production.

Since carbon emission is directly connected to electricity consumption, the most obvious way to reduce GHG emission is to 1) reduce consumption by increasing conservation efforts and 2) employing cleaner sources of electricity and power.

### **2.2.2: How Electricity is Wasted**

According to a BBC news report on wasted electricity, the average British household “has up to 12 gadgets on standby or charging”. Appliances on standby use an incredible amount of electricity, and since they are not actually in use during this period, the electricity consumed is virtually wasted. Standby buttons, common on many appliances such as televisions, serve no real technological function but are intended for customer convenience – thus, if consumers simply chose products without the standby option, a large portion of electricity could be conserved which in turn would reduce carbon emissions.



It has also become apparent that necessary lights, like those illuminating streets, are misdirected and not correctly shielded, resulting in a loss of usable light which is technically a waste of coal-generated power as well – in GHG terms, it is carbon being needlessly emitted into the atmosphere. With proper placement of these fixtures, the light can be more efficiently used and therefore would not squander energy.

### **2.2.3: How to Make Consumption More Efficient**

When discussing electricity consumption and the effect that it has on the environment you generally want to increase the efficiency in order to reduce the amount of energy wasted. There are some barriers that must be overcome in order to allow more efficient and energy saving policies to be implemented. Some of these are the limited supply and availability of materials regarding efficiency methods. There is also a general lack of communication of information about the effects of inefficient energy production. There also needs to be more people willing to invest in efficient energy production companies. In order for these companies to get up and running there needs to be less discouraging fiscal policies related to companies who produce efficient energy. There are also ways for companies to improve their efficiency themselves without outside help.

A California-based company called Austin Energy is currently implementing new methods to increase their overall efficiency along with increasing overall awareness about energy efficiency. What they are doing is spending 2% of their revenue on efficiency and management programs. This cuts the electricity usage by .8%-1% every year that the programs are running. This boils down to a cost savings of 2-3 cents per kilowatt hour for the local consumer. There is also a new code being used in California for building efficiency called Title 24 which is very similar to the International Energy Conservation Code. In addition, it is suggested that energy efficiency codes be updated at least once every three years. They are also trying to implement programs that will train local officials to use and implement the new codes. These programs are designed to target certain aspects of the community which as a whole will reduce their energy usage. Some of these programs encourage builders to design and build buildings that exceed the efficiency standard. Also, new programs are implemented in order to increase consumer education in regards to in home energy consumption and how to reduce it.

There are also some new incentives in the private sector that are encouraging people and organizations to reduce their energy needs. These include a 10% reduction of energy use per floor area by 2008 and a 15% reduction by 2011 for all state agencies and universities. There are also new requirements for state buildings to have a LEED silver certification or better, also that all state buildings will be 20% more efficient by 2015. What encourages these programs to actually happen is a new low interest loans for energy-conserving retrofits to buildings. The combination of all these aspects will hopefully have a substantial impact on the energy consumption and efficiency in the future.

## **2.2.4: Understanding Energy Usage**

The first step in energy reduction is to understand energy use; this can be done in a number of ways. Some of these are as easy as going out and checking the electricity meter, while others include new energy management technologies. While most of these take some background knowledge to understand, the basic concept is very simple: the more that is known about the energy used the easier it will be to reduce.

Some easy energy accounting methods are so basic that they can even be implemented in the private sector, such as checking the regular bills. All that is necessary to do this is an energy bill and a spreadsheet. While this is not the most in depth analyses, a basic overview of consumption trends will become apparent. If more in depth analyses is necessary a daily or even hourly reading from an electricity meter will give a good estimate of energy usage. This type of data collection shows when energy is being used the most and when its being used the least, allowing a possible reduction in peak demand. The point of collecting data is to look for trends so a database, which collects and stores data for future analysis, is an obvious tool for energy accounting. This works well for large companies because there may be different people who need this information for several reasons.

The point of recording the data gained from energy management programs is to reduce the energy used. There are some easy ways to do this using the data collected, one simple way is awareness. Many times, simply showing that energy is being wasted is enough to change the way the energy is being used. Another basic way to make sure progress is made in energy management is to set realistic goals. All of this can only be started if there is a central organization devoted to energy accounting and management. When dealing with large companies that use enormous amounts of energy the way that they manage their energy has a large impact on global carbon emissions.

## **2.3: WPI's Electricity Usage and Expenditure**

Worcester Polytechnic Institute, as a community of over 4,000 students, faculty and staff, is a significant consumer of electricity. The problems associated with trying to provide electrical power to a large community are considerable indirect carbon emissions, sizeable, and ever-increasing, utility bills, as well as the cost and effort of maintaining a complex distribution infrastructure. As energy prices continue to rise and global warming becomes a very important concern, heavy electricity consumers such as WPI have a responsibility, as well as an intrinsic motivation, to reduce their electricity consumption and attendant costs.

The electricity provider for WPI is National Grid, which distributes electricity generated by Select Energy. The energy for the main campus, which is all the buildings bounded by Institute Rd., Boynton St., Salisbury St. and Park Ave., is directed through a central power meter in the basement of Stratton Hall, and from there is distributed to the individual buildings on the main campus. The electrical distribution chart is presented in Appendix G. The majority of the buildings have a single sub meter, however several buildings share meters. Also, the capabilities of each meter vary widely, from simple, analog energy meters, to digital meters that record many different data types. A more thorough analysis of meter functionality is discussed in Section 4.3.

The information we gathered from the electricity bills showed that in 2006, WPI used about 18.8 gigawatt-hours (GW-hrs.) of energy, at a cost of \$2.4 million. The total annual Plant Services budget was approximately \$12.7 million, making electricity consumption almost 19% of this budget. Approximately 10.6 GW-hrs. of the total energy were consumed during peak hours, while the remaining 8.2 GW-hrs. were used during off-peak hours. This distinction is important mainly because peak hour usage incurs a higher net charge than off-peak usage. The other important factor in the electricity bill is the peak power demand. This is the highest amount of power drawn by the campus in a given time period (not necessarily during peak hours), and it is a very large percentage of the energy distribution charges. The complete breakdown of a WPI electricity bill is given in Appendix A. WPI maintains a fairly consistent peak power demand, slightly fewer than 2 megawatts (as measured by the central meter) on the main campus. Additionally, for electricity generated primarily through the burning of fossil fuels, a kilowatt-hour of energy produced yields about 1.6 pounds of carbon emissions (DOE, 2002), thus WPI's indirect carbon emissions are in the neighborhood of 30 million pounds per year.

One way to quantify the relative electrical efficiency of the campus as a whole is to calculate the annual energy consumption per capita and then compare this number to other universities. WPI has a population of roughly 4,260 students, faculty and staff, and thus consumes approximately 4,300 kilowatt-hours per capita per year. In comparison, based on our calculations, Middlebury College uses 6642 kWh/person (Dagan, 2004), the University of Colorado uses 4300 kWh/person (U of Colorado, 2006), and the University of Canterbury (New Zealand) uses 1160 kWh/person (U of Canterbury, NZ, 2006). Thus WPI is doing relatively well as a consumer of electricity, but there is room for improvement, both in reducing consumption and expenditure. Improvement options are discussed in depth in Section 5.2.

## ***2.4: Monitoring Electricity Consumption***

As mentioned previously, monitoring electricity consumption is integral to conserving electrical energy, and first you must understand what you are actually monitoring and how this is being done.

### **2.4.1: Scope of monitoring**

The goal of electricity monitoring is to evaluate the electrical performance on a variety of different levels of electricity use. These levels range from extremely broad- such as the electricity use of entire countries, to extremely focused- such as the electricity usage of individual outlets, and even the electrical performance of individual components in a single device.

In evaluating the electricity consumption on WPI's main campus, it was determined that the best practical method for electricity monitoring is building-level analysis. Analyzing individual electrical components and appliances is too specific, and monitoring each electrical outlet would be difficult to implement. This allows for both acceptable amounts of data and reasonable feasibility.

## **2.4.2: Dimensions of measurement**

Dimensions of measurement are used to quantify the different aspects of electricity use, and there are many of them used for this end.

### **2.4.2.1: Voltage and Current**

The two most fundamental measurable quantities in building level analysis are voltage and current. Voltage is the electrical potential and is typically measured in volts. Current is the flow of charge across a conductor and is measured in amperes (amps). A good analogy for voltage and current is the flow of water through a hose: voltage is equivalent to the water pressure that induces the flow of water, while current is equivalent to the size (cross sectional area) of the hose itself and thus the amount of water flowing. Voltage and current together are used to determine power usage, but are also individually important. Voltage is used for component selection and safety considerations. The greater the voltage of an electric circuit is, the more robust the components must be, and more safety precautions must be taken. Current is used for the selection of wire and other conductors. Suitable conductors must be selected for various amounts of current or unsafe amounts of heat may be generated. Because our project is focused on energy usage and not component selection, we have focused on voltage and current in conjunction for determining power usage.

### **2.4.2.2: Real Power vs. Apparent Power**

Apparent power is simply the voltage multiplied by current in a circuit, and its unit of measurement is VA (volt amps). Real power is the amount of work a circuit is actually doing instantaneously. The power factor is the ratio of real power to apparent power and is usually a percentage (Midwest Energy, 2007). Reactive power is the power required to return the difference of apparent and real power to the electric company (Sauer, 2003). Power is transmitted in the form of alternating current (AC), in that it is constantly fluctuating. The reason that apparent power and real power differ, and that the power factor is usually less than one, is that different types of components store power (conductors) and then use it off-phase from source (inductors). This difference is usually due to large induction motors found on heavy-industrial sites (Nave, 2006). Although the power factor is useful for instantaneous energy usage accounting, it was not used for serious analysis due to both the lack of industrial sized induction motors and meters able to measure it.

### **2.4.2.3: Harmonic Distortion**

The power factor is directly affected by the total harmonic distortion or THD. As mentioned previously, supplied electricity is in the form of alternating current. It is delivered at a certain frequency, which is another measurable dimension, and the amount of power fluctuates between a maximum and minimum value typically 60 times per second. THD is the percentage difference between either the voltage or current signals and an ideal 60 Hz signal, and greatly affects the efficiency of a transformer (PG&E,

1993). The k-factor is a value assigned to a particular load that describes to what degree the load is off-frequency from ideal signal, and ranges from 1 (a simple resistive circuit) to 40 (a highly harmonic circuit) (Federal Pacific, 2007). To increase efficiency there are different transformers designed for different k-factor applications.

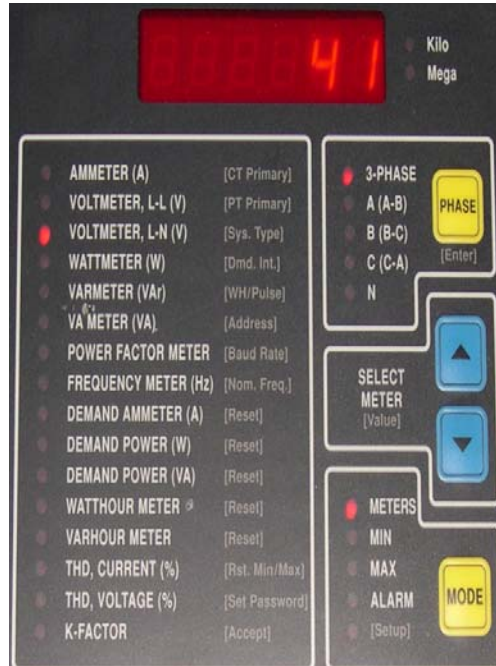

**Figure 1: Digital Power Meter in Alden Hall**

#### **2.4.2.4: Instantaneous Power Usage**

Instantaneous power usage (IPU) is a key dimension for analysis. It is equivalent to the amount of real power that a circuit is using in a single instant and is measured in Watts (W or kW). IPU is constantly fluctuating due to changes in load conditions and because of this, data is only useful when the reading time is specified. The resultant data is important for determining how load profiles change over different times of day. For example one would expect an academic building to use the greatest amount of power during the day, when lectures are in session and the labs or in use. Conversely one would expect dormitories to use the greatest amount of power during the evening hours, when lighting is in use, and appliances (televisions, computers, microwave ovens, etc.) are on.

Instantaneous power usage can be used to identify problems: electricity usage “hot-spots”. These can be found by examining aberrant usage data. For example: a piece of data shows a large spike in IPU in an academic building during a certain time where a large electricity usage is uncharacteristic for an academic building. Upon investigation it is found that a dated automated fan system is malfunctioning and using more electrical power than necessary.

#### **2.4.2.5: Maximum Power Usage**

Maximum power usage (MPU) is simply the maximum value of instantaneous power usage within a specified period of time. Like IPU it is also measured in Watts (W or kW). Accounting for maximum power usage is important for a number of reasons. As mentioned in the billing section, WPI is billed for the maximum power demand, as the electricity provider must be able to supply this amount of electricity at any time.

Monitoring MPU can be used to save money on demand charges. For example: it is found that one building's MPU is responsible for a significant portion of the maximum power demand of the entire campus resulting in a large demand charge. Upon further investigation it's also found that two electrical power intensive experiments are occurring during this time of MPU. If the demand charge is significant enough it may be deemed necessary to implement electricity usage policies and stagger power-intensive experiments.

#### **2.4.2.6: Total Energy Usage**

Total energy usage is the basis for most energy monitoring systems. Physically it is the total amount of electrical energy used between two points in time. It is the primary cost associated with electricity use and is used to relate electricity consumption and environmental impact. The most common unit for total energy usage is the kilowatt-hour (kWhr), and is power usage (kW) multiplied by time (hr). Mathematically it is the instantaneous power usage integrated between two different times. Because of this, an IPU monitor could also be used to measure total energy usage reasonably accurately if enough IPU readings could be taken (on the order of  $>1/\text{sec}$ ). Total energy usage is found by taking the difference between two kWhr meter readings. For example, an initial reading is taken from a building's kWhr meter and found to be 10,000,000 kWhrs. This single reading doesn't mean anything except that the building has used 10,000,000 kWhrs since the meter has been installed or reset. Then a week later a second reading is taken and found to be 10,010,000 kWhrs. A difference of these two values is taken and the building is found to have used 10,000 kWhrs during that week. This value can be manipulated to obtain average daily consumption or other useful pieces of information. Other values can be incorporated to yield different types of information, such as electricity usage per building area, or building population.

Total energy usage is incredibly important for building level analysis. Similar to IPU, it can be used to find "hotspots", but in a different way. It is more suited to gauge buildings electricity usage compared to other buildings. For example, when comparing two dormitories, it is found that one building is consistently using twice as much energy per resident than the other. Upon further investigation it is found that the lighting system in the problem building is old and in need of an overhaul.

## **2.5: Case Studies and Examples**

Monitoring systems have been successfully employed at numerous facilities and have yielded substantial savings in energy consumption and expenditure. Colleges and universities are excellent places to put such monitoring technology to work – with an abundance of facilities on campus, including, but not limited to, computer labs, machine shops, dining areas and residence halls, schools consume a considerable amount of energy.

Perhaps because college-aged students are, as a collective generation, more environmentally-conscious than older adults, universities have proven to be effective places at which to monitor energy usage because the consumers are, for the most part, genuinely concerned about the consequent findings of such observations. Nearly every institution of higher learning has a club or organization devoted to the safekeeping of the environment, and these associations would most certainly be interested in the findings of a school-wide monitoring system. For environmentally-conscious individuals, the results of monitoring are more than just numbers – they represent numerous opportunities to reduce consumption and improve the wellbeing of the environment on levels ranging from local to worldwide.

### **2.5.1: Gustavus Adolphus College**

Located in St. Peter, Minnesota, Gustavus Adolphus College is a private, 4-year liberal arts institution with approximately 2,600 full-time students (Gustavus Adolphus College, 2007). One of the many on-campus organizations is the Gustavus Greens, a group of environmentally-minded Gustavus students that take part in initiatives to promote environmental awareness and action (Gustavus Greens). Events sponsored by the club include such activities as a Valentine's Day candlelit dinner (energy free), Tupperware sales with the goal of phasing out the use of to-go boxes in the dining hall, an annual event called Earth Jam, and the replacement of older light bulbs with more efficient Energy Star light bulbs. In fact, Gustavus Adolphus was so successful with their light bulb-based energy reduction efforts that Energy Star requested that they be the Official Energy Star College (Gustavus Greens, 2007). Gustavus Greens also hosts numerous speakers and conferences on topics such as sustainability and environmentally-friendly behaviors.

Possibly the most notable of events in the Gustavus Greens' history is the Campus Energy Wars. This inter-college competition to have the highest percentage reduction in February energy usage started on the Carleton College campus in Northfield, Minnesota, as a friendly rivalry between dorms. The idea took hold at various other Minnesota schools and by the following year it had grown into what it is today – a statewide competition between 15 schools to cut back on energy consumption. Friendly competition further fuels the desire of students to reduce their overall impact on the environment, as evidenced by the first-year Carleton results – energy use decreased by a total of 16.3% in the underclassmen dorms in the month of February that year. In February 2007 during the state-wide competition, dorm electricity usage at Carleton was

reduced by 21% and the overall campus electricity reduction was 10.1%. The total reduction percentage translates into 155,600 pounds of carbon dioxide prevented from entering the atmosphere (Dana, 2007).

The Greens sponsored this event at Gustavus Adolphus and students participated eagerly – appliances were unplugged, lights turned off and thermostats lowered for the month of February. During this period, additional light bulbs were replaced with more efficient fluorescent bulbs (provided by St. Peter Municipal Utilities) to further decrease energy usage. In order to scrutinize the amount of electricity used, as well as the amount of electricity conserved, a monitoring system (comprised largely of Echelon e3 100 series data loggers) is in place that provides real-time data for electricity usage in 11 dorms and 12 academic/administrative buildings (Gustavus Adolphus, 2007).

The actual competition only ran through the month of February, but Gustavus Adolphus students continue to monitor electricity and provide feedback to the college community regarding usage. The information is posted online and is updated hourly, so students and faculty can keep an eye on how much electricity their dorm or office building is using on that very day. Real live feedback is inspirational in reduction efforts – if a member of the Gustavus community is able to see the usage and would also be able to see any cutbacks in usage, they are much more likely to attempt conservation efforts than someone who is unaware of the current situation and would also not be able to visualize any improvements.

Although Macalester College ultimately had the greatest total energy (heat and electricity) reduction at the conclusion of the competition, Gustavus Adolphus championed as the school with the largest reduction in electricity alone, ending the contest with an 8.9% cutback (Callahan, 2005).

The upshots of Campus Energy Wars proved advantageous to all involved – in addition to the environmental benefits in the short-term, student participators had the opportunity to practice valuable conservation techniques that hopefully have since become ingrained in their daily life. However, measuring consumption for the purpose of competition was a task in itself and this contest demonstrates how important it is to have accurate feedback in terms of usage data. If students had not been kept informed of their progress, their efforts would have gradually waned due to lack of interest (as well as the inability to actually compete with one another). It is important to remember that you cannot manage or reduce what you cannot measure, and therefore it is crucial to have accurate monitoring systems in place when attempting to implement reduction efforts.

## **2.5.2: Oberlin College**

Oberlin College, located in Oberlin, Ohio, is another example of an educational institution where students have made remarkable progress in reducing their environmental impact in terms of electricity consumption. In a 2007 two-week targeted period of reduction efforts, Oberlin students in 18 dormitories and eight additional on-campus houses cut their electricity consumption by an average of 56%, and in 2005 students were able to save the school a total of \$5,120 in electricity costs (Oberlin College, 2007). The students involved in the development of the monitoring system used to obtain these statistics stated that the ultimate goal of the competition was to make people aware of what they can do to reduce energy use in the long term, beyond the reach



of the annual two-week long competition (Oberlin College, 2007). The system implemented at Oberlin also provides students with real-time feedback on water consumption, and together, the electricity and water data combine to further motivate students to conserve resources. The overall aim of the system is to “change behavior in ways that minimize resource consumption and maximize environmental performance” by the use of consumption feedback – once again, evidence that you cannot efficiently manage that what is not accurately measured (Oberlin College, 2007).

## Chapter 3: Methodology

Our focus of this project was to provide a comprehensive status report for the electricity meters in each individual building on the WPI campus. We also aimed to develop general patterns in electricity usage based on the data we have gathered from the buildings which have functioning meters. As the project progressed, we integrated these two aspects into both a tool for both identifying consumption trends, as well as possible problems, and a general guideline as to how the school's ability to measure this information can be significantly improved. As an ultimate result, we hope that this resource would be a beneficial step in the effort to lower WPI's electricity consumption, and subsequently its indirect carbon footprint. We achieved this through the accomplishment of three specific objectives:

- 1) Collect and analyze WPI's electricity usage data
- 2) Evaluate the current state of WPI's electricity monitoring system
- 3) Represent our findings in an appropriate visual medium
- 4) Recommend improvements to be made to the metering system

### ***3.1: Evolution of the Project***

The initial goal of our project was to identify ways in which WPI could reduce its electricity consumption on its main campus. We planned to visit each academic building on the main campus to record their usage, and then break this information down further based on percentages of lab space in a building, the amount and types of equipment in the buildings, as well as several other factors that affect the amount of energy consumed by a given building. From here we hoped to be able to develop usage profiles and recognize patterns that could suggest inefficiencies where conservation techniques or equipment improvements might be able to reduce both consumption and expenditure. Unfortunately, we ran into a number of obstacles that required us to change our tactics, and ultimately the final goal of our project.

Initially, there was the problem of access. To actually read any of the meters, we needed to contact and set up an appointment with a Plant Services electrician who would then walk us around the campus and let us into the rooms which housed the sub meters. This significantly limited the amount of times we could collect data from meters, as well as the times of day when we could visit them, which meant the scope of our data was to be limited from the start.

Next, we realized the main issue that presented the greatest problem, our inability to gather good data. Many of the meters were in some state of non-functionality (as is discussed in the analysis section), and thus we could only get usable electricity data from a small fraction of the buildings on campus. It was at this point that we redirected our goal from reducing electricity consumption to improving WPI's ability to monitor its electricity consumption, and therefore be in a position to find ways to reduce it in the future. This yielded the two main results of our project, which are a comprehensive

status report for the metering system on WPI's main campus, and recommendations on some tools that could be implemented to improve this system.

### ***3.2: Analysis of WPI's Electricity Bills***

Through the detailed analysis of WPI's electricity bills we obtained general electricity consumption data and were able to establish trends in its use. We obtained from Plant Services the bills spanning June 15, 2005 to October 26, 2006, and using the total kW-hr consumption data, were able to find average electricity consumption rates per day, within the bills' respective periods. The periods varied from 15 to 70 days, with the average being 34 days, giving us approximately monthly trend data. Data from a year previous to the date of the bill was obtained from information on the side of the bill. We also used these bills to establish total yearly electricity consumption and expenditure.

### ***3.3: Collection of Electricity Usage Data***

The data we collected came from two primary sources, our reading and recording of the information from the electricity meters, and the usage and expenditure data included in the electricity bills. As was mentioned in the previous section, the data from the electricity meters was woefully incomplete. In total, we were able to read different sub meters around the campus on four different occasions. We visited every academic building that had meters at least two different times, in order to determine how much energy was used over a known time period. Altogether, we visited 16 academic buildings over a total time period of approximately 4 months. It would've been possible to generate more complete usage profiles for the buildings with working meters, however the fact that walking from building to building reading the meters presented a large time commitment, leading to scheduling issues which prevented us from reading the meters as often as we would have liked.

Additionally, the amount of time and effort it required to visit each meter, manually record the data, then analyze it and compile it into graphs precluded us from developing an analysis of requisite depth to determine effective energy reduction practices. A breakdown on a smaller timescale would be necessary to determine specific inefficiencies. Also, since several of the meters were non-functional, we needed to refer to the electricity bills to fill in the large gaps in the total campus energy usage and power demand. From these bills we were able to determine the total annual expenditure and consumption. However, the only way to obtain a complete building by building breakdown is to visit each sub meter on a regular basis and this is impossible without working meters and a person who is willing to regularly visit the meters, and then subsequently record and compile the data. For us, this represented a time commitment of 3-4 hours a day.

When walking around to read the various electricity meters on campus its good to have a data sheet with you. For this reason we created a data sheet that organizes our data into categories that are helpful when analyzing the information we receive from the meters. The categories that we thought would be most insightful to WPI's energy usage were instantaneous power, peak power, and energy usage. The collection sheets will

have the date of collection the amount of power/energy being used and the change in power/energy between each reading. There will also be a list of all the buildings in which we are looking at meters regardless if we checked them at that specific date. There is also a main sheet that is organized by date so that we can check to see which buildings were visited on which day and what types of readings we got. This shows which meters were working at what time and whether or not a meter is giving all of the information needed. These data sheets will make it very easy to see the trends in power usage on campus by graphing the data over the course of time to see what changes have been made.

### 3.4: Establishing an Electricity Meter Inventory

In the course of our project, we created a means for keeping an inventory of all the electricity meters on campus. This inventory includes information about their capabilities, setbacks, and general functionality, and was produced in the following steps:

- We discussed various parameters that determine a meter's functionality. These included items like whether or not a meter was running, how easy it was to read, its ability to measure various sorts of power usage, etc.
- These parameters were compiled into a form that was filled out as we went about the campus collecting electricity data.
- The information we collected in the form was inputted into a Microsoft Access database. Just one database contains all the meter data we compiled.
- Using Microsoft Access's built-in report generator, we generated the meter inventory. There were many ways to generate the inventory, including having all the data on one, gluttonously informational, page. However, it was decided for clarity's sake to have each page be dedicated to one meter.

bld_id	mtr	mtr_id	running	mult_disp	rdng_accrcy	type	mke	mdl	kwhrs	kwhrs_fnctn	inst_usge	in
▶ Alden and Riley	<input checked="" type="checkbox"/>	ah1	<input checked="" type="checkbox"/>	<input checked="" type="checkbox"/>	<input checked="" type="checkbox"/>	Digital	Siemens	4700 Digital Me	<input checked="" type="checkbox"/>	<input checked="" type="checkbox"/>	<input checked="" type="checkbox"/>	<input checked="" type="checkbox"/>
Atwater Kent	<input checked="" type="checkbox"/>	ak1	<input type="checkbox"/>	<input checked="" type="checkbox"/>	<input type="checkbox"/>	Analog	GE		<input checked="" type="checkbox"/>	<input type="checkbox"/>	<input checked="" type="checkbox"/>	<input type="checkbox"/>
Campus Center	<input checked="" type="checkbox"/>	cc1	<input checked="" type="checkbox"/>	<input checked="" type="checkbox"/>	<input type="checkbox"/>	Digital	GE	Power Leader E	<input checked="" type="checkbox"/>	<input type="checkbox"/>	<input checked="" type="checkbox"/>	<input type="checkbox"/>
Daniels and Mo	<input checked="" type="checkbox"/>	dm1	<input checked="" type="checkbox"/>	<input checked="" type="checkbox"/>	<input checked="" type="checkbox"/>	Digital	Power Logic		<input checked="" type="checkbox"/>	<input type="checkbox"/>	<input checked="" type="checkbox"/>	<input type="checkbox"/>
Ellsworth Apart	<input checked="" type="checkbox"/>	ei1-16	<input checked="" type="checkbox"/>	<input checked="" type="checkbox"/>	<input checked="" type="checkbox"/>	Analog			<input checked="" type="checkbox"/>	<input checked="" type="checkbox"/>	<input type="checkbox"/>	<input type="checkbox"/>
Ellsworth Apart	<input checked="" type="checkbox"/>	em1	<input checked="" type="checkbox"/>	<input checked="" type="checkbox"/>	<input checked="" type="checkbox"/>	Analog			<input checked="" type="checkbox"/>	<input checked="" type="checkbox"/>	<input type="checkbox"/>	<input type="checkbox"/>
Fuller Apartmen	<input checked="" type="checkbox"/>	fi1-26	<input checked="" type="checkbox"/>	<input checked="" type="checkbox"/>	<input checked="" type="checkbox"/>	Analog			<input checked="" type="checkbox"/>	<input checked="" type="checkbox"/>	<input type="checkbox"/>	<input type="checkbox"/>
Fuller Apartmen	<input checked="" type="checkbox"/>	fm1	<input checked="" type="checkbox"/>	<input checked="" type="checkbox"/>	<input checked="" type="checkbox"/>	Analog			<input checked="" type="checkbox"/>	<input checked="" type="checkbox"/>	<input type="checkbox"/>	<input type="checkbox"/>
Fuller Labs	<input checked="" type="checkbox"/>	fl1	<input checked="" type="checkbox"/>	<input type="checkbox"/>	<input type="checkbox"/>	Digital/Analog	GE	Electronic Regis	<input checked="" type="checkbox"/>	<input checked="" type="checkbox"/>	<input checked="" type="checkbox"/>	<input checked="" type="checkbox"/>
George C. Gord	<input checked="" type="checkbox"/>	lb1	<input checked="" type="checkbox"/>	<input checked="" type="checkbox"/>	<input type="checkbox"/>	Analog		DS485	<input checked="" type="checkbox"/>	<input type="checkbox"/>	<input checked="" type="checkbox"/>	<input type="checkbox"/>
Harrington Audit	<input checked="" type="checkbox"/>	ha1	<input checked="" type="checkbox"/>	<input checked="" type="checkbox"/>	<input checked="" type="checkbox"/>	Analog			<input checked="" type="checkbox"/>	<input checked="" type="checkbox"/>	<input checked="" type="checkbox"/>	<input type="checkbox"/>
Higgins Labs ar	<input checked="" type="checkbox"/>	hl1	<input checked="" type="checkbox"/>	<input checked="" type="checkbox"/>	<input checked="" type="checkbox"/>	Digital	Power Logic		<input checked="" type="checkbox"/>	<input type="checkbox"/>	<input checked="" type="checkbox"/>	<input type="checkbox"/>
Kaven Hall	<input checked="" type="checkbox"/>	kh1	<input type="checkbox"/>	<input checked="" type="checkbox"/>	<input type="checkbox"/>	Analog	GE		<input checked="" type="checkbox"/>	<input type="checkbox"/>	<input checked="" type="checkbox"/>	<input type="checkbox"/>
Olin Hall	<input checked="" type="checkbox"/>	oh1	<input type="checkbox"/>	<input checked="" type="checkbox"/>	<input type="checkbox"/>	Analog			<input checked="" type="checkbox"/>	<input type="checkbox"/>	<input checked="" type="checkbox"/>	<input type="checkbox"/>
Power House (w	<input checked="" type="checkbox"/>	ph1	<input checked="" type="checkbox"/>	<input checked="" type="checkbox"/>	<input checked="" type="checkbox"/>	Digital	Elster	ALK1+	<input checked="" type="checkbox"/>	<input checked="" type="checkbox"/>	<input type="checkbox"/>	<input type="checkbox"/>
Salisbury Labs	<input checked="" type="checkbox"/>	sl1	<input checked="" type="checkbox"/>	<input type="checkbox"/>	<input type="checkbox"/>	Analog	Westinghouse		<input checked="" type="checkbox"/>	<input checked="" type="checkbox"/>	<input type="checkbox"/>	<input type="checkbox"/>
Stoddard A	<input checked="" type="checkbox"/>	sa1	<input checked="" type="checkbox"/>	<input checked="" type="checkbox"/>	<input type="checkbox"/>	Analog	Westinghouse		<input checked="" type="checkbox"/>	<input checked="" type="checkbox"/>	<input type="checkbox"/>	<input type="checkbox"/>
Stoddard B	<input checked="" type="checkbox"/>	sb1	<input checked="" type="checkbox"/>	<input checked="" type="checkbox"/>	<input type="checkbox"/>	Analog	Westinghouse		<input checked="" type="checkbox"/>	<input checked="" type="checkbox"/>	<input type="checkbox"/>	<input type="checkbox"/>
Stoddard C	<input checked="" type="checkbox"/>	sc1	<input checked="" type="checkbox"/>	<input checked="" type="checkbox"/>	<input type="checkbox"/>	Analog	Westinghouse		<input checked="" type="checkbox"/>	<input checked="" type="checkbox"/>	<input type="checkbox"/>	<input type="checkbox"/>
Stoddard snow	<input checked="" type="checkbox"/>	sm1	<input checked="" type="checkbox"/>	<input checked="" type="checkbox"/>	<input checked="" type="checkbox"/>	Analog	Westinghouse		<input checked="" type="checkbox"/>	<input checked="" type="checkbox"/>	<input type="checkbox"/>	<input type="checkbox"/>
Washburn	<input type="checkbox"/>		<input type="checkbox"/>	<input type="checkbox"/>	<input type="checkbox"/>	None			<input type="checkbox"/>	<input type="checkbox"/>	<input type="checkbox"/>	<input type="checkbox"/>
*	<input type="checkbox"/>		<input type="checkbox"/>	<input type="checkbox"/>	<input type="checkbox"/>				<input type="checkbox"/>	<input type="checkbox"/>	<input type="checkbox"/>	<input type="checkbox"/>

Figure 2: Meter inventory cover page

# *Electricity Meter Evaluation*

<i>Building:</i>	The name of the building being evaluated
<i>Metered</i>	Is there a meter present? (functioning or not)
<i>Meter Running</i>	Does it appear to be functioning? (is meter disc rotating?)
<i>Multiplier Displayed</i>	Is the multiplier displayed? (yes if digital or if =1)
<i>Reasonable Data</i>	Does the data obtained from the meter appear to be reasonable?
<i>Meter Type</i>	Type of meter (analog or digital)
<i>Meter Manufacturer</i>	The manufacturer of the meter
<i>Meter Model</i>	The model of the meter (be as specific as possible)
<i>Meters Energy Usage</i>	Does the meter display a kW-hr reading or can one be obtained?
<i>Energy Meter Works</i>	Does it appear to be working?
<i>Meters Instantaneous Power</i>	Does the meter display an instantaneous power use reading?
<i>Instantaneous Power Meter Works</i>	Does it appear to be working?
<i>Meters Maximum Power Consumption</i>	Does the meter display a maximum power consumption reading?
<i>Maximum Power Meter Works</i>	Does it appear to be working?
<i>location</i>	A Description of the location of the meter
<i>comments</i>	Any additional information about the meter

**Building:** Higgins Labs and Alumni

---

<i>Metered</i>	<input checked="" type="checkbox"/>
<i>Meter Running</i>	<input checked="" type="checkbox"/>
<i>Multiplier Displayed</i>	<input checked="" type="checkbox"/>
<i>Reasonable Data</i>	<input checked="" type="checkbox"/>
<i>Meter Type</i>	Digital
<i>Meter Manufacturer</i>	Power Logic
<i>Meter Model</i>	
<i>Meters Energy Usage</i>	<input checked="" type="checkbox"/>
<i>Energy Meter Works</i>	<input checked="" type="checkbox"/>
<i>Meters Instantaneous Power Consumption</i>	<input checked="" type="checkbox"/>
<i>Instantaneous Power Meter Works</i>	<input checked="" type="checkbox"/>
<i>Meters Maximum Power Consumption</i>	<input checked="" type="checkbox"/>
<i>Maximum Power Meter Works</i>	<input checked="" type="checkbox"/>

*location* Basement of HL on bldg transformer

*comments*

**Figure 3: Example of meter status report (see Appendix F.2 for details)**

As you can see in Figure 3, this report presents the information from our database in a readable format that is easy to understand. The breakthrough in this report is for the first time, there is a single entity to house meter data. Over the previous term, we found out that there is much ambiguity in the present state of the energy monitor system. Nobody we talked to seemed to know of which meters were functioning, including the WPI electricians. This inventory at least sheds light on the current monitoring system. Also, we integrated our inventory data with the GIS model of the WPI campus to produce a campus map showing not only the location of meters, but their functionality as well.

### **3.5: Representation of Collected Data**

The first step was to collect data, and once there is a sufficient amount of data, collected trends can be identified. After we had collected a significant portion of the data we realized that finding significant trends was harder than it appeared. With the current state of the metering system on WPI's main campus, it is very difficult to gain usable data from a variety of different buildings. This led us to look for an example of good data on campus, which we found in the Ellsworth and Fuller apartments, and this in turn allowed us to see the energy used by the individual apartments.

From here we decided that one of our key graphs should show the holes that we encountered in our data collection (see Figure 7 or Appendix B). We found that one of the most shocking and easiest ways to show this is to show the percentage of energy that each working building is using out of the entire main campus. This allowed us to show that there are some buildings that are functioning normally but also that there is a huge hole in this data, being that the majority of the buildings on the main campus don't have functioning meters.

#### **3.5.1 Various Modes of Data**

When collecting data on electricity usage, total energy is the most insightful type of data. It shows which buildings are drawing what amount of energy compared with the rest of the main campus. This is done by reading the meter at the powerhouse which shows a total of all WPI's electricity usage for the main campus. By finding out the total energy usage of WPI's main campus and of specific buildings on campus you can see what percentage of the total energy usage each working meter is recording. This allows you to locate specific buildings as hotspots and try to reduce their energy usage.

Another aspect of the energy usage data is the individual break down of Ellsworth and Fuller apartments (see Figures 8 and 9 or Appendix C and D). This is necessary for another group which is working on the heating efficiency of these apartment complexes. This data shows a break down of the total energy usage for each apartment; this allows us to see energy usage over a time period.

The most important part of the data collection next to energy usage is peak power or peak demand which is the highest amount of electricity being drawn at any one point in time through the specified meter (see Figure 10). This is important because the higher this amount is, the more power the electricity company must be able to provide to that

building at any given time. So reducing the peak demand of a building will reduce the amount of money it costs to run that particular building. This data can be slightly misleading if a meter has been reset, which may cause a curious drop in the peak power of a building. Ideally, the peak demand of a building is consistent and won't change much over the year. By graphing the peak power over time, we are able to see if a meter has been reset or if a specific building has had a power spike or a general increase in energy usage.

The last aspect of the data collection is the instantaneous power which is the amount of power running through the meter as it is being read. This doesn't show too much when looked at over a time period of more than a week. What this can be useful for is to see how a specific building's energy usage fluctuates over the course of a day or even a week. This is difficult to arrange with WPI because as of now in order to read the meters the head electrician has to be there, so this kind of data collection would require his assistance for the better part of a day. A possible solution to this problem would be WPI implementing a data collection system, which would record different types of data from the different meters on campus.

### **3.5.2 Types of Visual Representation**

When dealing with large amounts of data the best way to represent it is visually; we used several different types of visual representation. By using a visual representation of the data you can show large amounts of information in a small area, or you can use the visuals to show the lack of data. There are two main ways that we went about displaying our data, graphs and maps. In the future a database may be able to be set up in order to have a large amount of data available to anyone who wants to use it in antecedent projects.

Our other main graph is of the energy used by the two apartment complexes, which enables us to show an example of what good data collection can do. After the second time we read the meters at the apartments, you could see significant trends in the amount of energy used from apartment to apartment. Once we found the amount of people in each apartment, we then organized the graph to show the data grouping the apartments with the same number of people in them together. This showed that the amount of energy used varied with the apartment size, but also with the individuals living in them. From here it is very easy to see which apartments are using the most amount of energy for the amount of people in them, which allows us to show which apartments could reduce their energy usage.

The second type of visualization that we used to show our data is a map (see Figure 4); this is a very useful tool when trying to show a large amount of data. We were originally given the idea of creating a map by Professor Carrera, who gave us the program MapInfo 8.5. This program can do a lot more than the application we used it for and is worth looking into in further detail. What we did at first was to find a usable map of campus from a past IQP group; this was done with the help of Professor Carrera. The next step was to learn how to use the program. After significant time and help a map was created that could be used to represent our data quickly and easily.





**Figure 4: Campus map showing meter locations and functionality**

Originally we wanted to include usage data in the map, but after some data collection we realized there was not a significant amount of usable data to do this. So we decided to use the map not only to give a visual of WPI's main campus but to show which meters were working and which of them were not. This was done with the help of the pod casts by Professor Carrera. The final map shows in green the working meters and in Red the non-functioning meters. It also shows which meters are analog and which are digital.

### **3.5.3: Use of Visualizations**

These visualizations came in very handy in our presentation but also allow the reader to easily see what we are talking about without having to read a description which can be lengthy and technical. With further and more in depth data collection visualizations like these will be able to show trends in specific buildings and as a campus itself. MapInfo can be further utilized by the addition of a database that will allow MapInfo to show a real time visualization of the energy being used on campus. In the end these visualizations are the final presentation of the months spent collecting data and can show all this data quickly and easily.

### **3.6: Research of Metering Improvement Options**

Upon the realization that the current monitoring system was inadequate, we set out to find options that would improve the system. Firstly, we identified areas in which the current system could use specific improvements. These included, but were not limited to, increasing the accuracy and specificity of the available data and establishing a functioning data collection system. From here, we researched companies that provided both metering and data logging hardware and software, and investigated the applicability and cost of these options. This included catalog and Internet research, and contacting company representatives. The results of this research are outlined in Section 4.4.

## Chapter 4: Results and Analysis

Through the course of this project, a number of results were achieved. WPI's monthly electricity bills were analyzed, and overall electricity use trends were established. A detailed inventory was taken of WPI's main campus electricity usage monitoring capability, giving us an idea of what is presently possible and viable. We also collected meter data to evaluate electricity consumption at the building level.

### 4.1: Electricity Bill Analysis

WPI's electricity bills are produced approximately monthly by Massachusetts Electric, a subsidiary of National Grid. Each bill encompasses the total costs incurred by WPI's electricity consumption over a varied period of days. Through the analysis of these bills, information can be obtained about total electricity usage on the WPI campus, and how the cost of this electricity is broken down.

#### 4.1.1: Cost Breakdown

Analyzing the cost of electricity does not directly effect electricity consumption. However, economics fuels social change and as such it is important to understand how electricity costs are broken down. Below are the percentages of an individual WPI electric bill, broken down into the charges received for each aspect of energy supply.

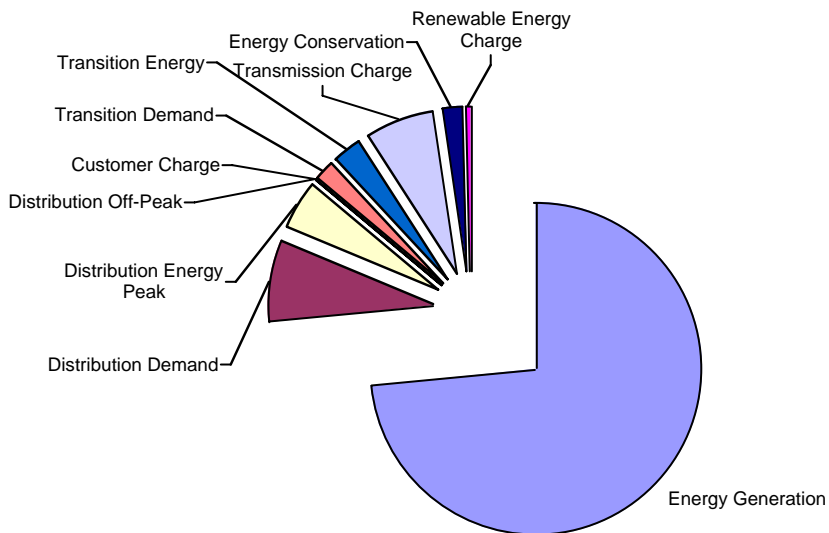

**Figure 5: Electricity Bill Breakdown (% of total cost)**

The primary cost is the actual energy generation cost. This goes to Select Energy, INC. for physically generating the electricity. The rest of the cost is for services provided by National Grid.

- Distribution charges result from National Grid delivering electricity to WPI.
- Demand charges are incurred when WPI uses its greatest amount of electrical power.
- Electricity delivered during hours of peak electricity usage are billed as peak charges, while electricity delivered during hours of nadir electricity usage are billed as off-peak charges, and are subtracted from the bill.
- Transition energy and demand charges result from the cost incurred by National Grid to purchase electricity from our energy provider: Select Energy.
- Transmission charges result from the cost in transmitting electricity from the source (the power plant) to National Grid.
- The renewable energy charge provides funding for renewable energy programs.

#### 4.1.2: Consumption Trends

The analysis of WPI's electricity bills yielded us consumption data for the entire WPI campus approximately monthly. This allowed us to evaluate electricity consumption trends throughout the school year.

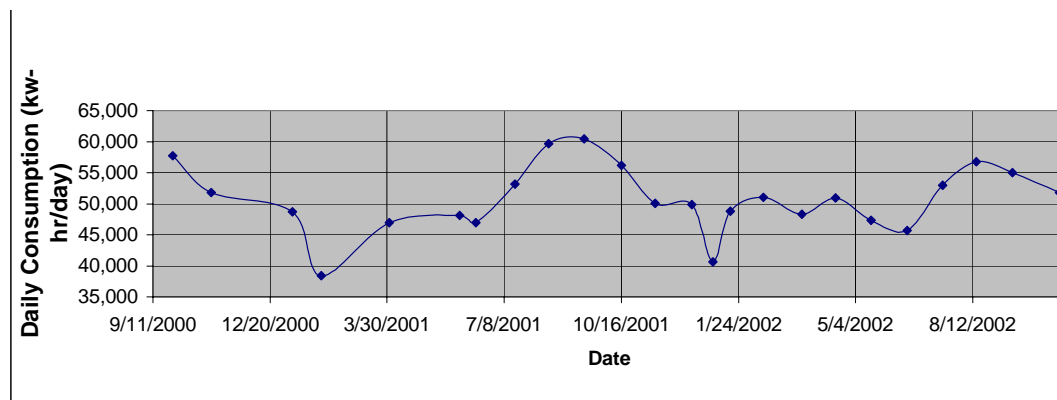

**Figure 6: WPI's approximate monthly electricity consumption**

It can be seen here that electricity usage peaks during the late summer months. It can be speculated that this is due the use of electrical air conditioning. It can also be seen that consumptions dips from December to January, most definitely due to the decrease in activity on the campus during winter break. It is interesting to note however, that it dips by only approximately 10,000 kW-hrs/day from non-vacation months, during the time of least activity on campus. Had we a better data collection system, it would be possible to pinpoint what was most responsible for this energy consumption, and efforts could be made to reduce our electricity use.

## **4.2: Electricity Consumption Data Analysis**

As a leading technical college, WPI boasts some of the best and most advanced technologies on its campus. But when it comes to energy accounting WPI is not at the forefront; its electricity metering system is incomplete and as of now no one seems to be even looking at the individual meters on each building. Because of this there is an overall lack of data when it comes to energy usage on a building by building basis. Without this data it becomes very difficult to account for all the energy used on the campus.

### **4.2.1: Breakdown of Campus Energy Use**

With the current state of WPI's metering system, there are many holes in the data that was collected from December 2006 until March 2007. As you can see in the graph below, 56% of the total power used on campus came from the other buildings that were either not read or were not functioning. The next highest amount of energy used was in Higgins Labs, which used almost 26% of the energy being consumed from December 7 2006 to January 31 2007. This figure leads us to believe that this meter is working, because that is a reasonable amount of energy for a building which contains lab equipment and computer labs. Daniels Hall, which also includes Morgan Hall and the dining room, used 6% of the energy during the 55 day period. This may seem low but when taking into account that this period runs through Christmas break it makes sense that the building would be using less energy while there are less people there. Fuller Labs was using 1% of the energy during that period, which shows that WPI probably shut down the computer labs during Christmas break. Otherwise this building may be using a higher amount of the total energy, but still not a significant amount, because despite the buildings size, it has a large lecture hall compared to the amount of computer lab space.

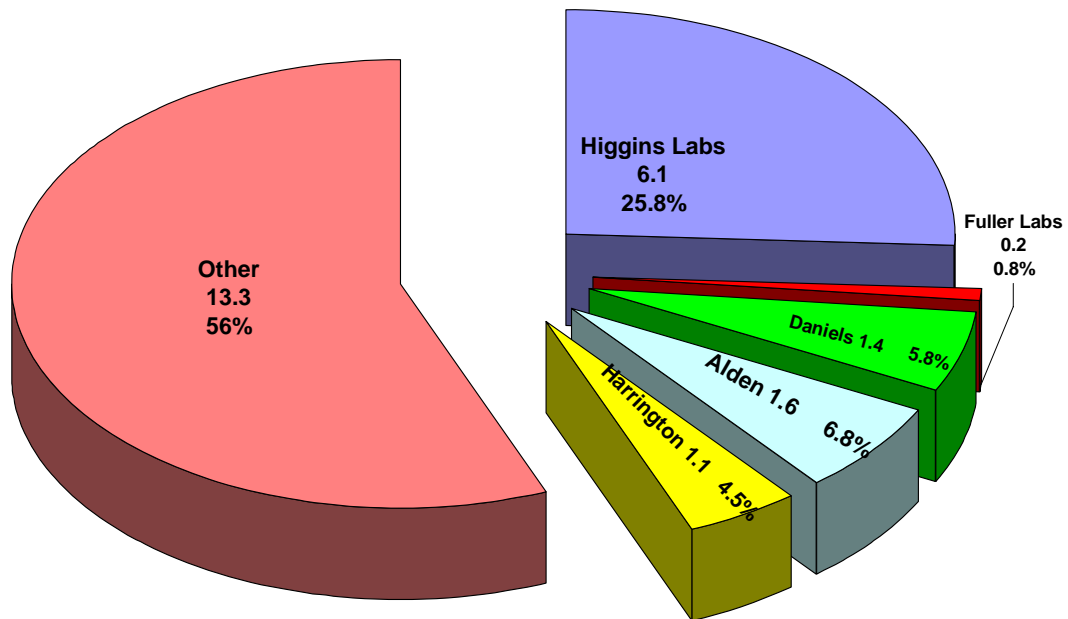

**Figure 7: WPI's Total Energy Usage Mwh/day (12/7/06-3/22/07)**

With over half of the energy used on campus unaccounted for it is very difficult to determine the consumption tendencies. Whether or not these meters aren't recording energy usage or just aren't working is one of the main flaws with the metering system at WPI. One of the other main problems is that when you want specific data, it's hard to come by if its there at all. As a leading tech school WPI should be at the fore front of technology and the current metering system does not allow WPI the necessary level of control.

#### **4.2.2: Fuller Apartments Usage Data**

With the lack of usable data available on WPI's main campus, an example of good metering was found in the Fuller and Ellsworth Apartments. The graphs below are examples of good metering and how it can easily show hotspots and inefficiencies. These are found by looking at the differences in the amount of energy used from apartment to apartment, even though some of them have the same amount of people. While this more than likely can be accounted for by the personal habits of the occupants, what this does show is how easy it is to see where energy is being wasted. With a little more investigation as to the habits of the people living in these apartments, the total amount of energy used by the apartments can easily be reduced. This type of data analyses can easily be used more effectively by WPI. If there was useful data for the total energy used by each building on the main campus then WPI would be able to see which buildings were spending the most money on energy. Then by reducing this

number they would not only save money but they would be reducing WPI's total carbon footprint.

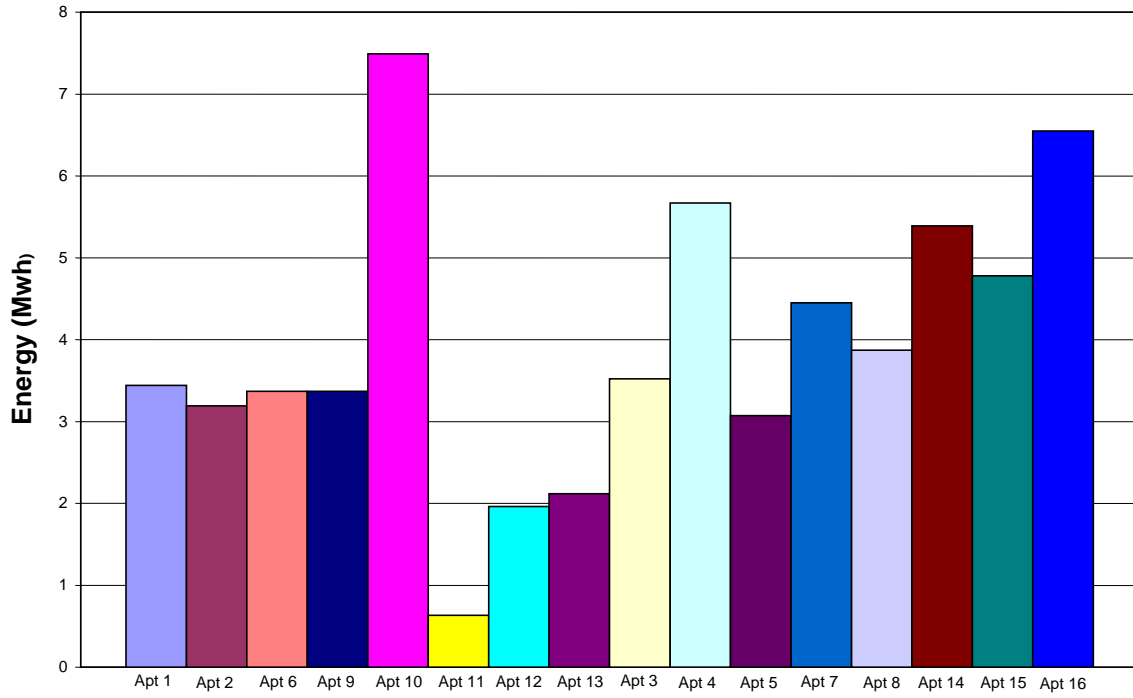

**Figure 8: Total Energy Usage for Ellsworth Apartments (2/13/07-3/22/07)**

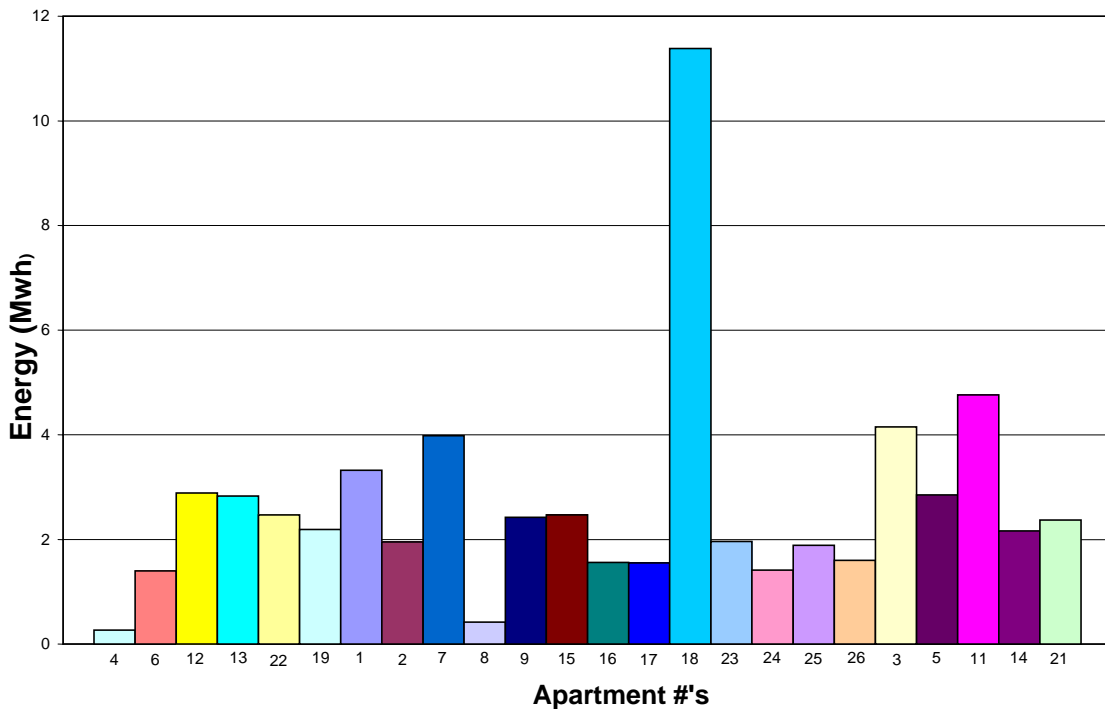
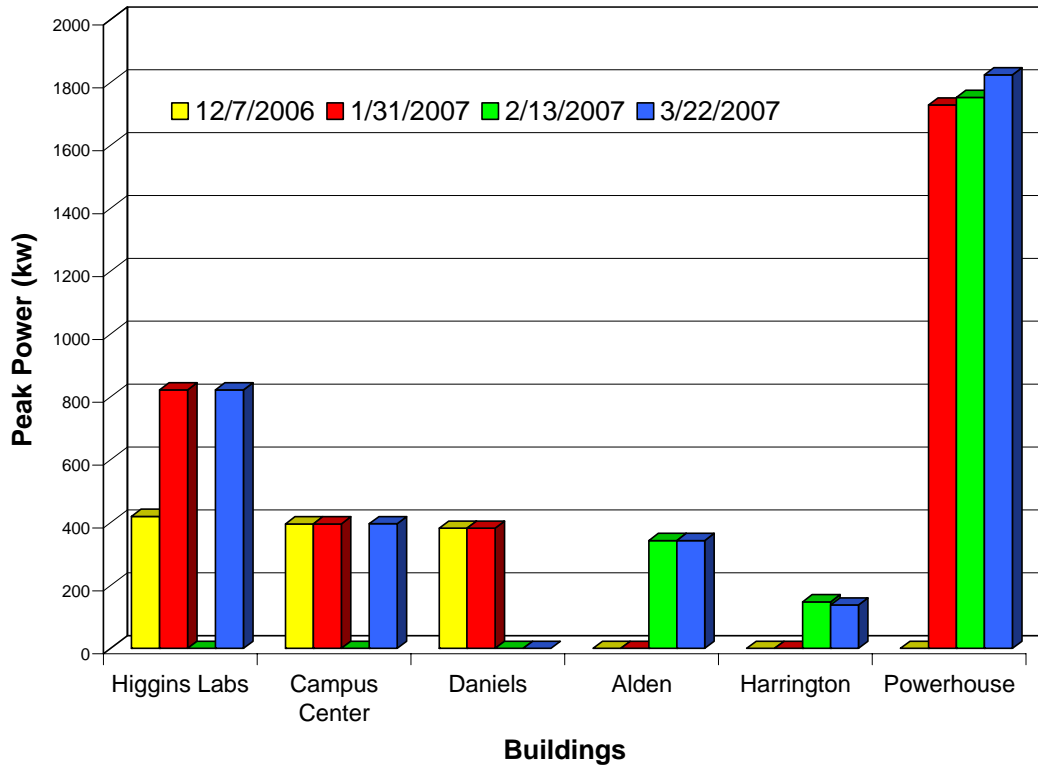

**Figure 9: Total Energy Usage for Fuller Apartments (2/13/07-3/22/07)**

### 4.2.3 Peak Power Usage on WPI Campus

Figure 10 represents the peak power or peak demand of the working meters on campus. The buildings that have working meters recording peak power are Higgins Labs, the Campus Center, Daniels, Alden Hall, Harrington Auditorium and the Powerhouse. The working meters were decided on by looking at the meters personally, and by looking at the other data given by them. It's important to note that just because there is no change in peak power, this does not mean the meter isn't working. The most important piece of information taken from this graph is the spike in power in Higgins Labs; this spike can not be accounted for because there is no in-depth analyses of the buildings on WPI's main campus. This is one of the pieces of information that would be clearly understood if an in-depth metering system were in place and taking readings from each building on a regular basis. With an in-depth analysis on a building by building basis, an energy increase like this can be easily accounted for. This will also possibly allow WPI to avoid an increase in peak demand campus wide, which would save a substantial amount of money. But a system like this would need working meters on a significant number of the buildings.





**Figure 10: WPI's Peak Power Usage (12/7/06-3/22/07)**

### **4.3: Electricity Meter Status Report Analysis**

Analyzing the Electricity Meter Status Report allowed us to truly evaluate the electricity metering system on the WPI campus. Various tables were generated and analyzed, and these tables are supplied in the appendices section of our project. It seemed as if each new analysis added to our original notion of the inadequacy of the current monitoring system at WPI.

#### **4.3.1: Total Energy Usage Meter Monitoring Analysis**

We investigated the metering system for 21 buildings on the WPI campus, assuming that both Ellsworth and Fuller Apartments each represented two buildings: one for the main building itself, and one for all of the individual apartments. Of these 21 buildings, 95% had a total energy usage meter of some kind in place, however only 48% gave accurate, reasonable data.

There were various reasons as to why the meters gave erroneous data. Both Fuller and Salisbury Laboratories' meters did not have multiplier values displayed. Kaven Hall's and Atwater Kent's (an electrical engineering building ironically enough) electricity meters were completely disconnected from the electric system. The Campus Center's kWhr meter was being reset (either internally or externally) at an unknown timescale, showing up as a negative energy usage in our results. The Stoddard residence

halls gave us invalid results for reasons unknown. The most probable explanation is a timescale issue, as opposed to an equipment malfunction, as it is clear that the meters are running.

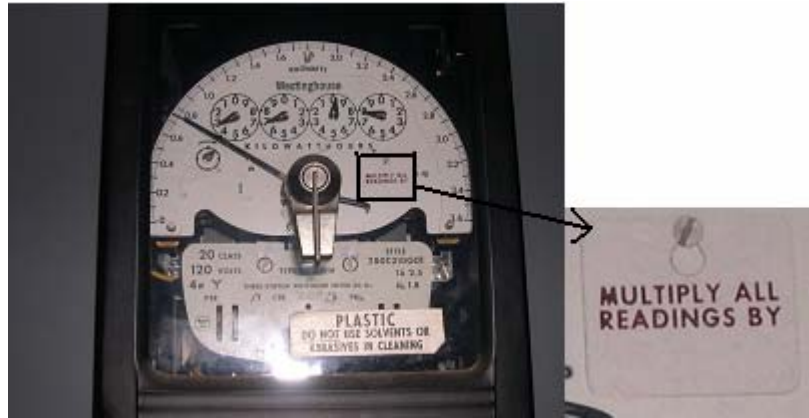

**Figure 11: Salisbury Labs Meter (no multiplier displayed)**

#### 4.3.2: Instantaneous Power Usage Monitoring Analysis

We found that 16 of 21, or 76% of the meters investigated had the ability to measure instantaneous energy usage. Of these 16 meters, 11 of them gave a reasonable reading. This represents a mere 52% of the total number of buildings surveyed.

The reasons for this are similar to the reasons for errors in the total energy readings: instantaneous power usage readings are meaningless if no multiplier values are present, and if the meter is disconnected it obviously won't give any sort of reasonable reading. The needle in Olin Hall's meter was off the buried, meaning that the building was using more power than the meter could read, yielding an inaccurate reading.



**Figure 12: Olin Hall's meter (needle is off the scale)**

### 4.3.3: Maximum Power Usage and Other Monitoring Analyses

Of the 21 buildings surveyed, three had digital meters, and all three of them could show maximum power usage. These were Higgins Laboratories, the Campus Center, and Alden/Riley Residence Hall. This represents 14% of the total number of buildings surveyed. Even though maximum power usage is a useful value, the meter didn't record when this value occurred, taking away the valuable dimension of time for analysis.

Two of the three digital meters had the capacity for more advanced monitoring such as power factor, and harmonic distortion. These meters were integrated in the power transformers of Higgins Laboratories and Alden/Riley Residence Hall, and make up less than 10% of the total number of buildings surveyed.



Figure 13: Advanced Digital meter for Alden and Riley Hall's

## 4.4: Improvement Options

After extensive research, the conclusion was reached that there are three main options for improvement. The first possibility is to do an overhaul of the meters, replacing all of them – working and non-working – with new devices, all of the same make and model. The other two options are similar in that they are both data logging systems, yet differ in the capabilities of the data loggers themselves.

### 4.4.1: Meter Replacement

A campus-wide overhaul of the electricity meters would give WPI a completely updated and standardized system. As previously mentioned, a large number of the meters are currently non-functional. Meter replacement, of both non-working and working meters, with the same make and model would ensure that information could be gathered and used in identifying trends and patterns.

We identified the Wattnode Plus meter as the best option for straightforward replacement. The Wattnode Plus is a digital meter with storage capabilities and can be networked with like meters in the system. Applications include sub-metering, demand management and phase load monitoring, and the meter puts a time stamp on each reading. With data displayed in an easy-to-read format and proper access, consumption information could be quickly read and gathered.



**Figure 14: Wattnode Plus Power Meter**

Each meter costs \$450 plus the additional price of installation (Echelon). The installation is a relatively simple process and the meters themselves are user-friendly; however, the major downfall of this option is that data collection must be done manually, which is both time-consuming and inefficient. The meters are located in the basements of the buildings and therefore student access to these areas is limited, making frequent meter reading a difficult task to accomplish. WPI's electricians and Plant Services personnel have free access to this information but do not have the time to take hourly or even daily readings of usage data. Replacing the meters would make data collection possible, but information would still not be readily available to students.

#### **4.4.2: Echelon e3 100 Data Logger**

The e3 100, manufactured by Echelon, is a data logger/internet server that is able to collect real-time data from energy meters and transmit it via the internet using the existing IP address on campus. The e3 100 stores the information from the meters as plain text files (up to 1024 kB), which are then downloadable via ftp and it is possible to write scripts to process that automatically. In order to use the e3 100, the existing meters must be replaced with meters that are compatible with the server. It was determined that the most suitable meter for this purpose is the Wattnode Plus (Echelon).



**Figure 15: The Echelon e3 100 Data Logger**

The cost of an e3 100 is \$750 and the compatible databasing and analysis software is an additional \$200, plus the cost of installation (Echelon).

#### **4.4.3: ElitePro Data Logger**

Manufactured by DENT Instruments, the ElitePro data logger is \$1200 plus an additional \$200 for the current transformers and \$150 for the ELOG software, which is used to graph and analyze trends and patterns in the data (DENT). Installation cost is negligible because the product requires no functioning meters in order to collect and transmit data, and the installation process of the logger itself is basic enough to be done by an electrician here at WPI.

The ElitePro can be configured to take readings from as frequently as once per second to as infrequently as once per every 24 hours (DENT). For our purposes, hourly readings would be best, and we would be able to database and graph the collected readings. This information could be uploaded to a website that is linked to the main WPI site, so the electricity consumption data would be accessible to anyone who visits the school's page. These real-time graphs would serve as an invaluable resource in analysis as well as in tracking problems and improvements, enabling WPI to check the accuracy of utility billing, track for power interruptions as well as verify electrical savings of lighting upgrades (when WPI makes such upgrades) – capabilities which will ensure reduced waste and streamlined operations.



**Figure 16: The ElitePro Data Logger**

There would be no need to phase in this system, as it does not require functional meters. Thus, replacement of our existing meters is not an issue and the fact that the ElitePro can take readings directly from the electrical system is an advantage because meters, even state-of-the-art digital ones like the Wattnode Plus, will quickly become obsolete and are inefficient ways of collecting data. A snapshot of the implementation of this system is shown in Figure 18.

## **Chapter 5: Conclusions and Recommendations**

The overall conclusion that we have come to through the course of this project is that the present metering system is clearly inadequate. This is obvious any way you look at it. The methods used to obtain usage data were obtained with all due effort and diligence, but were clearly not effectual. The data obtained by these methods was unsatisfactory and full of holes, and these results were confirmed in analyzing the actual data system itself.

### **5.1.1: Electricity Bills**

The data obtained by electricity bill analysis gave us an approximate relationship between campus wide electricity use and the time of year. However, the period over which each piece of data represents was not constant, averaging around one month, which proved to be not precise enough to aid in in-depth analysis. Also, the data collected represented the entire campus as a whole, giving us general electricity usage trends, and not contributing anything for building level analysis.

### **5.1.2: Building Electricity Use**

As mentioned in the methodology section, obtaining building level meter readings was a very tedious process. It involved walking to remote, often nearly inaccessible areas of the campus, taking up hours of time not only for our group, but also for WPI Plant Services staff members. The coordination of these meter inspections also took time and planning. Due to scheduling conflicts we could only read the meters sporadically, in a restricted window of time.

As stated in the previous section, approximately 56% of the electrical energy used on campus is unaccounted for. Instantaneous and maximum power usage readings lose much of their analytical value without recording the date and time that the reading was taken.

### **5.1.3: Meter Status Report**

Examining the results from the Meter Status Report analysis confirms these ideas of the inadequacy of the system. Over half of the meters we examined did not give valid total energy usage readings, and only 14% displayed maximum power usage, and no meters provided time and date information.

It is clear through the evaluation of the data we have collected throughout the course of this project, that the present electricity usage monitoring system here at WPI is inadequate, and not up to the task of monitoring electricity usage in an attempt to reduce consumption. If WPI hopes to be environmentally responsible with its energy use, a necessary first step is to improve the present electricity usage monitoring system.

## 5.2.4: Final Recommendation

Based upon categorical rankings that include ease of installation, user friendliness and data recording and transmission capabilities, the ElitePro data logger was determined to be the best option for WPI. The factors of cost and payback were also incorporated into the final decision – the ElitePro was found to be superior in all of the aforementioned categories.

Initially, the 6 dorms (Morgan Hall, Riley Hall, Daniels Hall and Stoddard A, B and C) should be outfitted with data loggers, one per building. The Ellsworth and Fuller apartments were omitted from consideration due to their slated demolition and the fact that each apartment is individually metered, making the cost prohibitive, potentially adding over \$60,000 to the overall cost. The cost of the 6 loggers (and the necessary current transformers for each logger) is \$8100. The accompanying ELOG software, used to analyze the collected data, is a one-time purchase that costs \$150 for the entire package. Installation cost is minimal, as the system can be set up by either Plant Services or engineering students. Therefore, the entire cost of the proposed short-term implementation of the system is approximately \$8,250, plus taxes and shipping charges.

Once in place in the 6 dorms, the system can be tweaked as students and administration work out the bugs and start to effectively make use of the capabilities of this technology. If the applications of the data logging system are as effective as expected, the second part of the implementation will be to install 10 additional loggers in the academic buildings (Higgins Laboratories, Campus Center, Kaven Hall, Alden Hall, Atwater Kent, Fuller Laboratories, the George C. Gordon Library, Olin Hall, Salisbury Laboratories and Washburn Shops). This division of the project is estimated to cost \$13,500 (10 loggers and the necessary current transformers). At the conclusion of this phase, nearly the entire campus will be outfitted with data loggers and information from a total of 16 buildings will be readily available online, at a total cost of approximately \$21,750.

\$22,000 is just a fraction of the amount of money that WPI spends on electricity yearly (roughly 1%). Using the feedback provided by the new system, electricity consumption can be significantly reduced. Even small percentage-wise cutbacks in usage will yield dramatic savings on electricity bills. Given these expected savings and educational opportunities, it is clear that implementing such a system will greatly benefit WPI now and in years to come.



	Price	User Friendliness	Simple Installation	Data Recording	Data Transmission	Storage Space
<b>Wattnode Plus Meter</b>	\$450	High	×	×		
<b>100 e3 Logger</b>	\$950 + meter cost	Low		×	×	1024 kB
<b>ElitePro Logger</b>	\$1350	High	×	×	×	512 kB

**Figure 17: Improvement Option Comparison Matrix**

### **5.3: Expected Results**

The benefits of an accurate monitoring system abound and once such a system is in place, additional advantages that have not even occurred to anyone at this time will most likely be realized. When students, faculty and administration are provided with a visual representation of usage data, they can then modify their behaviors and attitudes in order to reduce their consumption. People, when supplied with feedback, are much more likely to exhibit the desired behavior than those that do not have feedback. As humans, we feel the need to know that our behaviors (and any changes we make in them) have a purpose.

#### **5.3.1: Eventual Savings**

An important consideration in determining the wisdom of implementing a system is the payback period. Given an estimate of roughly \$25,000 to update the main campus (equipment plus software plus installation costs) with the ElitePro data logging system and its software, the payback period can be relatively short with even modest improvements in energy consumption. If the system yields a reduction of peak energy usage by 1%, the savings would be roughly \$15,000 per year (using \$0.08 per peak kilowatt-hour) at the school's current rate of energy usage. Reducing the peak demand by 1% could save up to an additional \$16,000 (est.), based on an average campus peak demand of 1.8 MW. The total estimated savings for this 1% reduction is around \$30,000, which is more than the estimated upgrade cost Gustavus Adolphus College cited a 6% reduction in peak energy use (source), which shows that there are attainable levels of improvement which could keep the payback period well within a year. The figure below shows the electricity monitoring ability at Gustavus Adolphus, using the system we recommend.

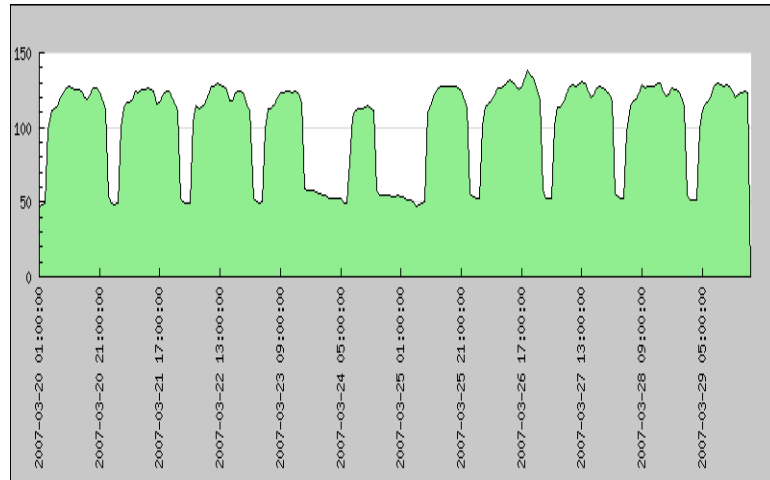

**Figure 18: An example of successful energy monitoring in a dorm at Gustavus Adolphus**

In addition, if the system is maintained and used for several years, with rising energy prices, the system could potentially yield significant savings, depending on its level of effectiveness. Certainly the initial investment required is justified by the possible savings in the future.

### 5.3.2: Project Opportunities

The implementation of a system like this provides ample educational opportunities in the form of subsequent IQPs and even MQPs. Successive IQPs would be able to continue to improve upon the new monitoring system, as there will most likely be program glitches and further small technical problems to work through. Even once the actual improvement stage is complete, IQP teams will have countless other project opportunities to take on because the environmental, economical and social applications of this system are limitless.

The MQP opportunities provided by the data logging project would be far more specific. For example, the networking aspects of the system are appropriate for a computer science project and electrical facets would be apropos for electrical engineering projects. Since these projects are more in depth and major-specific than IQPs, the number of MQPs available would be significantly less, but the educational possibilities are still viable.

## Chapter 6: Works Cited

- Callahan, Colleen. April 19, 2007. *The Report Cards Are In*. Retrieved on May 2, 2007 from:  
<http://www.users.csbsju.edu/record/archive/2007/04/19/news/the-report-cards-are-in.html>
- Clean Air-Cool Planet. (2004). *Get informed*. Retrieved on September 10, 2006.  
From: <http://www.cleanair-coolplanet.org/information/>
- Dana, Juliet. April 23, 2007. *Campus Energy Wars Generate Victory*. Retrieved on May 14, 2007 from:  
<http://apps.carleton.edu/news/?content=content&module=features&id=299194>
- DENT Instruments. (2007). *ElitePro Energy Logger*. Retrieved on April 1, 2007 from:  
<http://www.dentinstruments.com/detailsElitePro.htm>
- Department of Energy. (2002) *Carbon Dioxide Emissions from the Generation of Electric Power in the United States*. Retrieved on April 20, 2007 from:  
[http://www.eia.doe.gov/cneaf/electricity/page/co2\\_report/co2report.html](http://www.eia.doe.gov/cneaf/electricity/page/co2_report/co2report.html)
- Echelon Corporation (2007). *Echelon: Products*. Retrieved on April 1, 2007 from:  
<http://www.echelon.com/products/cis/>
- Federal Pacific. (2007) *The Load*. Retrieved on April 29, 2007 from:  
<http://www.federalpacific.com/university/kfactor/chapter7.html>
- Gustavus Adolphus. (2007). *Campus Pedals for Energy Wars*. Retrieved on May 2, 2007 from:  
<http://www.gustavus.edu/epep/learnMore/?story=60>
- Gustavus Adolphus College. (2007) *Gustavus Electricity Data*. Retrieved on April 25, 2007 from: <http://gts.gac.edu/power/>
- Gustavus Adolphus. (2007). *Gustavus Greens*. Retrieved on May 1, 2007 from:  
<http://www.gustavus.edu/orgs/greens/about.shtml>
- Gustavus Adolphus. (2007). *Quick Facts About the College*. Retrieved on April 24, 2007 from:  
<http://www.gustavus.edu/news/GAfacts.cfm>

- Green Building Solutions. (2007). *LEED: Leadership in Energy and Environmental Design*. Retrieved May 20, 2007 from:  
[http://www.greenbuildingsolutions.org/s\\_greenbuilding/sec.asp?TRACKID=&CID=50&DID=50](http://www.greenbuildingsolutions.org/s_greenbuilding/sec.asp?TRACKID=&CID=50&DID=50)
- M. Douglas Dagan. (2004) *A Summary of Energy Consumption and Greenhouse Gas Emissions at Middlebury College*. Retrieved on March 23, 2007 from:  
[www.middlebury.edu/NR/rdonlyres/26273E73-9E1D-4283-864C-1C6E9E5B74F9/0/Emissions\\_InvD\\_dagan.pdf](http://www.middlebury.edu/NR/rdonlyres/26273E73-9E1D-4283-864C-1C6E9E5B74F9/0/Emissions_InvD_dagan.pdf)
- Midwest Energy. (2007) *Glossary of Terms*. Retrieved on May 16, 2007 from:  
<http://www.mwenergy.com/glossary.html>
- Myhr, Dr. Franklin Henry. (1998). *Overview of Fossil Fuel Energy Resources*. Retrieved on September 10, 2006. From:  
<http://www.cpast.org/Articles/fetch.adp?topicnum=14>
- Nave, Carl R. (2006) *Power Factor*. Retrieved on March 20, 2007 from:  
<http://hyperphysics.phy-astr.gsu.edu/hbase/electric/powfac.html>
- Oak Ridge National Laboratory. (2006) *Hydropower*. Retrieved on September 23, 2006 from:  
<http://www.ornl.gov/info/ornlreview/rev26-34/text/hydmain.html>
- Oberlin College. (2007). *Oberlin College News and Features*. Retrieved on May 13, 2007 from:  
<http://www.oberlin.edu/news-info/04may/folkschedule.html>
- Oberlin College. (2007). *Campus Resource Monitoring System*. Retrieved on May 13, 2007 from:  
<http://www.oberlin.edu/dormenergy/environment.htm>
- Pacific Gas and Electric. (1993) *Power System Harmonics*. Retrieved on March 20, 2007 from:  
[http://www.pge.com/docs/pdfs/biz/power\\_quality/power\\_quality\\_notes/harmonics.pdf](http://www.pge.com/docs/pdfs/biz/power_quality/power_quality_notes/harmonics.pdf)
- Pimentel, Rodrigues, Wane, Abrams, Goldberg, Staecker, Ma, Brueckner, Trovato, Chow, Govindarajulu, Boerke. (1994). *Renewable Energy: Economic and Environmental Issues*. Retrieved on September 10, 2006.  
From: <http://dieoff.org/page84.htm>
- Sauer, Peter W. (2003) *What is Reactive Power?* Retrieved on March 20, 2007 from:  
[http://www.pserc.wisc.edu/Sauer\\_Reactive%20Power\\_Sep%202003.pdf](http://www.pserc.wisc.edu/Sauer_Reactive%20Power_Sep%202003.pdf)

U. of Canterbury, NZ. (2006) *Monthly kWh Profile*. Retrieved on March 21, 2007 from:  
<http://www.fm.canterbury.ac.nz/engineering/energyreadings/Monthly%20kWh%20Profile/rframe.htm>

U. of Colorado. (2006) *Total Energy Usage*. Retrieved on April 20, 2007 from:  
[http://ecenter.colorado.edu/energy/images/about\\_clip\\_image\\_full.jpg](http://ecenter.colorado.edu/energy/images/about_clip_image_full.jpg)

## Appendices

# Appendix A: WPI's Electricity Bills (6/15/05-10/26/06)

## A.1: WPI's Monthly Electricity Bill, Page 1

Account Number  
**19111 15250 05**



Pay This Amount  
**\$152173.36**  
 Amount Enclosed  
 \$ \_\_\_\_\_



#BWNFKKP \*\*C097  
 #1911115250054#  
 WPI PLANT SERVICES  
 MAIN CAMPUS POWER  
 100 INSTITUTE RD  
 WORCESTER MA 01609-2247

905191111525005 0015217336

2 1 14 B2 ATTN: JOHN MILLER



4660

**To Reach Us**  
 Customer Service: 1-800-322-3223  
 Credit Department: 1-866-395-0315  
 E-mail: CustomerService@us.ngrid.com  
 Website: www.nationalgrid.com

Pay This Amount  
**\$152173.36**

Account Number  
**19111 15250 05**

Bill Date  
**JUN 20 2006**

**SERVICE ADDRESS**      **LOAD ZONE** WCMASS      **905191111525005**  
**183 WEST ST WORCESTER MA**      **WPI , CY. 14**

**SERVICE PERIOD**  
**MAY 18 TO JUN 16 2006**      **29 DAYS**

METER NUMBER	RATE	METER PRESENT	READING PREVIOUS	METER CONST	KWH USAGE	ACTUAL DEMAND
A04848559	PEAK	4873	4614	2400	621600	3672.0 KVA
Q04848559	OFF PK	5762	5469	2400	703200	3264.0 KW
M04848559	G-3			2400		
					1324800	

**NATIONAL GRID**  
 RATE: TIME OF USE G-3

<p><b>NEXT METER READ DATE:</b>                      AVOID INTEREST PAY BY:                      JULY 18</p>	<p>PREVIOUS BALANCE \$ 81840.28                      PAYMENT-THANK YOU 05/22/06 -41090.46                      PAYMENT-THANK YOU 06/16/06 -40749.82                      BALANCE FORWARD .00</p>
--	--

MONTH	TOTAL KWH	DELIVERY SERVICES:	
J 06	1324800	CUSTOMER CHG	69.62
M	1420800	DISTRIBUTION CHG	
A	1476000	DEMAND	3.75000 X 3304.8 KVA= 12393.00
M	3021600	ENERGY PEAK	.01171 X 621600 KWH= 7278.94
J 06	732000	ENERGY OFF-PEAK	-.00035 X 703200 KWH= -246.12
		TRANSITION CHG	
		DEMAND	.90000 X 3304.8 KVA= 2974.32
		ENERGY	.00324 X 1324800 KWH= 4292.35
		TRANSMISSION CHG	.00762 X 1324800 KWH= 10094.97
		ENERGY CONSERVATION	.00250 X 1324800 KWH= 3312.00
		RENEWABLE ENERGY CHG	.00050 X 1324800 KWH= 662.40
		HIGH VOLTAGE MTR DISC	40831.48 X 1.00%= -408.31
		HIGH VOLTAGE DEL DISC	-.4600 X 3304.8 KVA= -1520.21
		<b>TOTAL CURRENT DELIVERY SERVICES</b>	<b>\$ 38902.96</b>
		<b>TOTAL DELIVERY SERVICES</b>	<b>\$ 38902.96</b>

Make check payable to: *National Grid*  
 Mail to: Processing Center, Woburn MA 01807-0005 • See reverse side.

### A.1.1: WPI's Monthly Electricity Bill, Page1, Section 1

<u>SERVICE PERIOD</u>				<u>TYPE OF METER READING</u>		
MAY 18 TO JUN 16 2006 29 DAYS				ACTUAL		
<u>METER NUMBER</u>	<u>RATE</u>	<u>METER PRESENT</u>	<u>READING PREVIOUS</u>	<u>METER CONST</u>	<u>KWH USAGE</u>	<u>ACTUAL DEMAND</u>
A04848559	PEAK	4873	4614	2400	621600	
	OFF PK	5762	5469		703200	
Q04848559	G-3			2400		3672.0 KVA
M04848559	G-3			2400		3264.0 KW
					<u>1324800</u>	

- Service Period: The period of time that this particular bill covers
- Type of Meter Reading: How the meter was read. In this "Actual" case it was read manually by an employee of National Grid
- Rate: The classification of the cost per unit of electricity. This changes with the type of institution and the time which the electricity was used (peak/off peak)

The "Meter Present" and "Reading Previous" are the actual readings displayed by the meter. They are then multiplied by the "Meter Const" to get the total number of kilowatt-hours of electricity used. This is displayed under "KWH Usage". Those two numbers added together represent the total amount of electricity used. The "Actual Demand" is the largest demand for electricity during the service period.

### A.1.2: WPI's Monthly Electricity Bill, Payment information

<u>NATIONAL GRID</u>		<u>RATE: TIME OF USE G-3</u>	
	PREVIOUS BALANCE		\$ 81840.28
	PAYMENT-THANK YOU	05/22/06	-41090.46
	PAYMENT-THANK YOU	06/16/06	-40749.82
	BALANCE FORWARD		<u>.00</u>
<u>DELIVERY SERVICES:</u>			
	CUSTOMER CHG		69.62
	DISTRIBUTION CHG		
	DEMAND	3.75000 X 3304.8 KVA=	12393.00
	ENERGY PEAK	.01171 X 621600 KWH=	7278.94
	ENERGY OFF-PEAK	- .00035 X 703200 KWH=	<u>-246.12</u>
			19425.82

- Customer Chg: Service charges for metering related expenses
- Distribution Chg: Service charges for delivering Electricity from National Grid to WPI.
- Demand: Service charge for National Grid to supply WPI electricity during its largest demand.
- Electricity delivered during peak hours raises costs, while electricity delivered during off peak hours is subtracted against the cost.

### A.1.3: WPI's Monthly Electricity Bill, Page 1, Section 3

TRANSITION CHG					
DEMAND	.90000	X	3304.8	KVA=	2974.32
ENERGY	.00324	X	1324800	KWH=	<u>4292.35</u>
					7266.67
TRANSMISSION CHG	.00762	X	1324800	KWH=	10094.97
ENERGY CONSERVATION	.00250	X	1324800	KWH=	3312.00
RENEWABLE ENERGY CHG	.00050	X	1324800	KWH=	662.40
HIGH VOLTAGE MTR DISC	40831.48	X		1.00%=	-408.31
HIGH VOLTAGE DEL DISC	- .4600	X	3304.8	KVA=	<u>-1520.21</u>
TOTAL CURRENT DELIVERY SERVICES					\$ 38902.96
TOTAL DELIVERY SERVICES					\$ 38902.96
-----					

- Transition Chg: The costs incurred by National Grid in purchasing power from the generation source for WPI.
- Transmission Chg: The cost of transmitting electricity from the source (power plant) to National Grid
- Energy Conservation: The cost of National Grid's programs that regulate power output based on present demand.
- Renewable Energy Chg: Provides funding for renewable energy programs.



### A.1.4 Electricity Bill, page 1, section 3

```
NEXT METER  
READ DATE:  
AVOID INTEREST  
PAY BY:  
  
JULY      18  
  
MONTH      TOTAL  
           KWH  
J 06      1324800  
M          1420800  
A          1476000  
M          3021600  
F  
J 06      732000  
  
BILLED DEMAND  
LAST 12 MTHS  
  
MIN      2894.4  
MAX      5839.2  
AVG      3651.8
```

Previous months' energy usage

Previous year's maximum

**A.2: WPI's Monthly Electricity Bill, page 2**

Account Number

19111 15250 05

Pay This Amount

PAGE: 2

Amount Enclosed

\$

**nationalgrid**



#BWNFKKP \*\*C097  
 #1911115250054#  
 WPI PLANT SERVICES  
 MAIN CAMPUS POWER  
 100 INSTITUTE RD  
 WORCESTER MA 01609-2247

905191111525005 0015217336

2 1 14 B2 ATTN: JOHN MILLER

**nationalgrid**

To Reach Us

Customer Service: 1-800-322-3223  
 Credit Department: 1-866-395-0315  
 E-mail: CustomerService@us.ngrid.com  
 Website: www.nationalgrid.com

Pay This Amount

\$152173.36

SERVICE ADDRESS LOAD ZONE WCMASS  
 183 WEST ST WORCESTER MA

905191111525005  
 WPI, CY. 14

SERVICE PERIOD  
 MAY 18 TO JUN 16 2006 29 DAYS

TYPE OF METER READING  
 ACTUAL

Account Number

19111 15250 05

Bill Date

JUN 20 2006

METER NUMBER	RATE	METER PRESENT	READING PREVIOUS	METER CONST	KWH USAGE	ACTUAL DEMAND
A04848559	HEF	4873	4614	2400	621600	3672.0 KVA
Q04848559	HEF	5762	5469	2400	703200	3264.0 KW
M04848559	HEF			2400		
					1324800	

NEXT METER READ DATE:  
 AVOID INTEREST PAY BY:

JULY 18

SELECT ENERGY, INC.

FOR QUESTIONS CALL: 1-888-810-5678

PREVIOUS BALANCE	\$ 324767.88
PAYMENT-THANK YOU 05/22/06	-203289.48
PAYMENT-THANK YOU 06/16/06	-121478.40
BALANCE FORWARD	.00

MONTH	TOTAL KWH
J 06	1324800
M	1420800
A	1476000
M	3021600
F	
J 06	732000

SUPPLIER SERVICES:

GENERATION CHARGE ENERGY CHARGE .08550 X 1324800 KWH= 113270.40  
 TOTAL COST OF ELECTRICITY \$ 113270.40

TOTAL SUPPLIER SERVICES \$ 113270.40

ACCOUNT BALANCE \$ 152173.36

BILLED DEMAND LAST 12 MTHS

MIN 2894.4  
 MAX 5839.2

## A.2.1: Electricity Bill, page 2, section 1

----- SELECT ENERGY, INC.		FOR QUESTIONS CALL: 1-888-810-5678
	PREVIOUS BALANCE	\$ 324767.88
	PAYMENT-THANK YOU 05/22/06	-203289.48
	PAYMENT-THANK YOU 06/16/06	<u>-121478.40</u>
	BALANCE FORWARD	.00
SUPPLIER SERVICES:		
<del>GENERATION CHARGE</del>		
ENERGY CHARGE	.08550 X 1324800 KWH=	113270.40
TOTAL COST OF ELECTRICITY		\$ <u>113270.40</u>
TOTAL SUPPLIER SERVICES		\$ 113270.40
ACCOUNT BALANCE		\$ 152173.36
-----		

- Select Energy, INC: The company that actually generates our electricity.
- Generation Charge: The actual cost of generating electricity, not including costs incurred by National Grid
- Account Balance: The total amount of money owed to National Grid

## Appendix B: Average Energy Usage Per Day of WPI's Main Campus

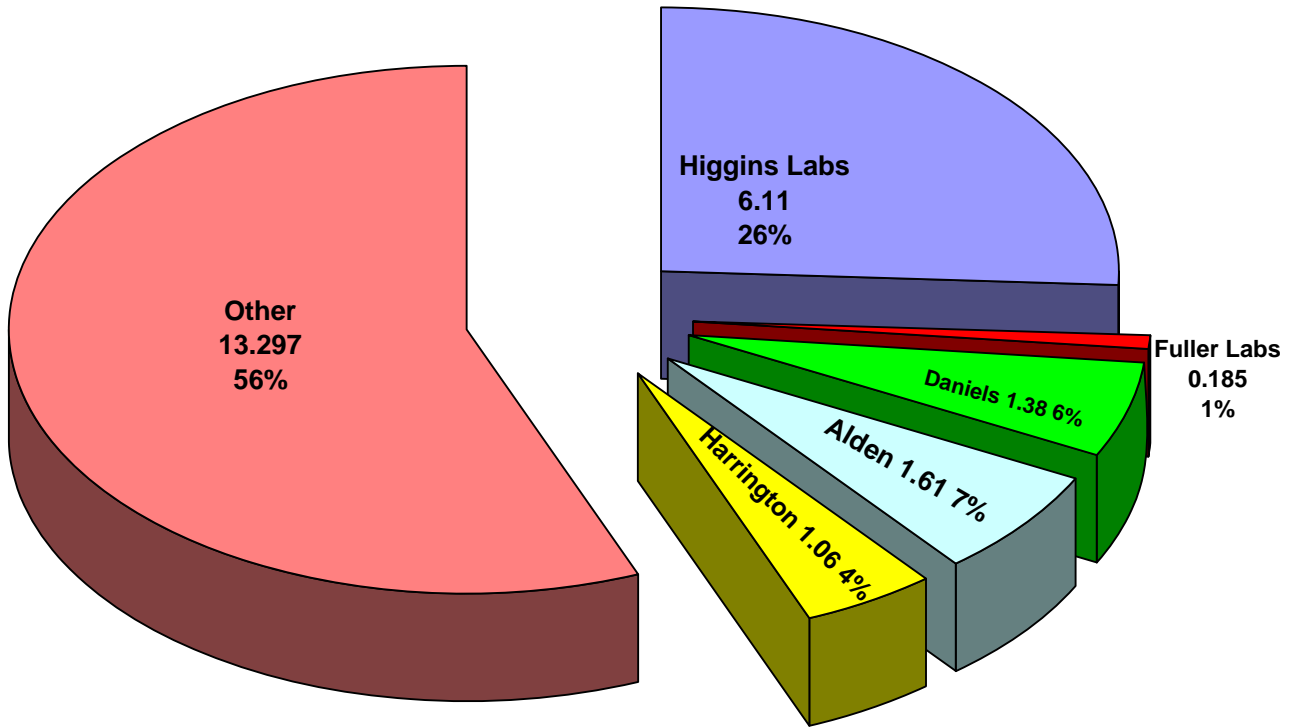

-Above is a pie graph showing the total energy (Mwh/day) in a number of buildings on campus out of the total energy used by the main powerhouse.

## Appendix C: Fuller Apartments Energy Usage

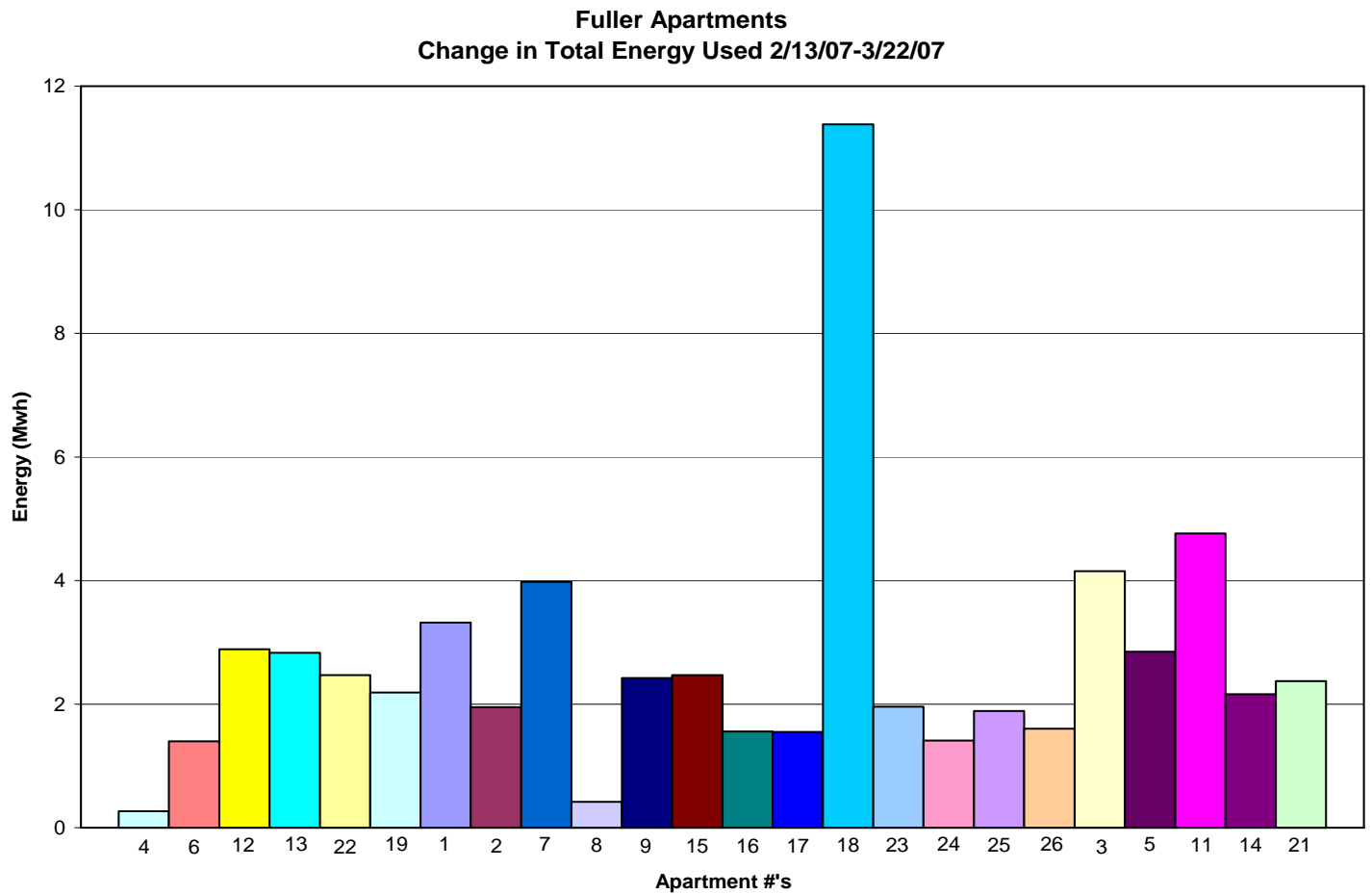

-Apartments 10 and 20 are the units with the meters in them and therefore aren't using a significant amount of energy

-Out of a total of 24 units 5 have 3 students in them, 13 have 5 students in them, 5 have 7 students in them and the RA is in #19 which has 4 students in it

## Appendix D: Ellsworth Apartments Energy Usage

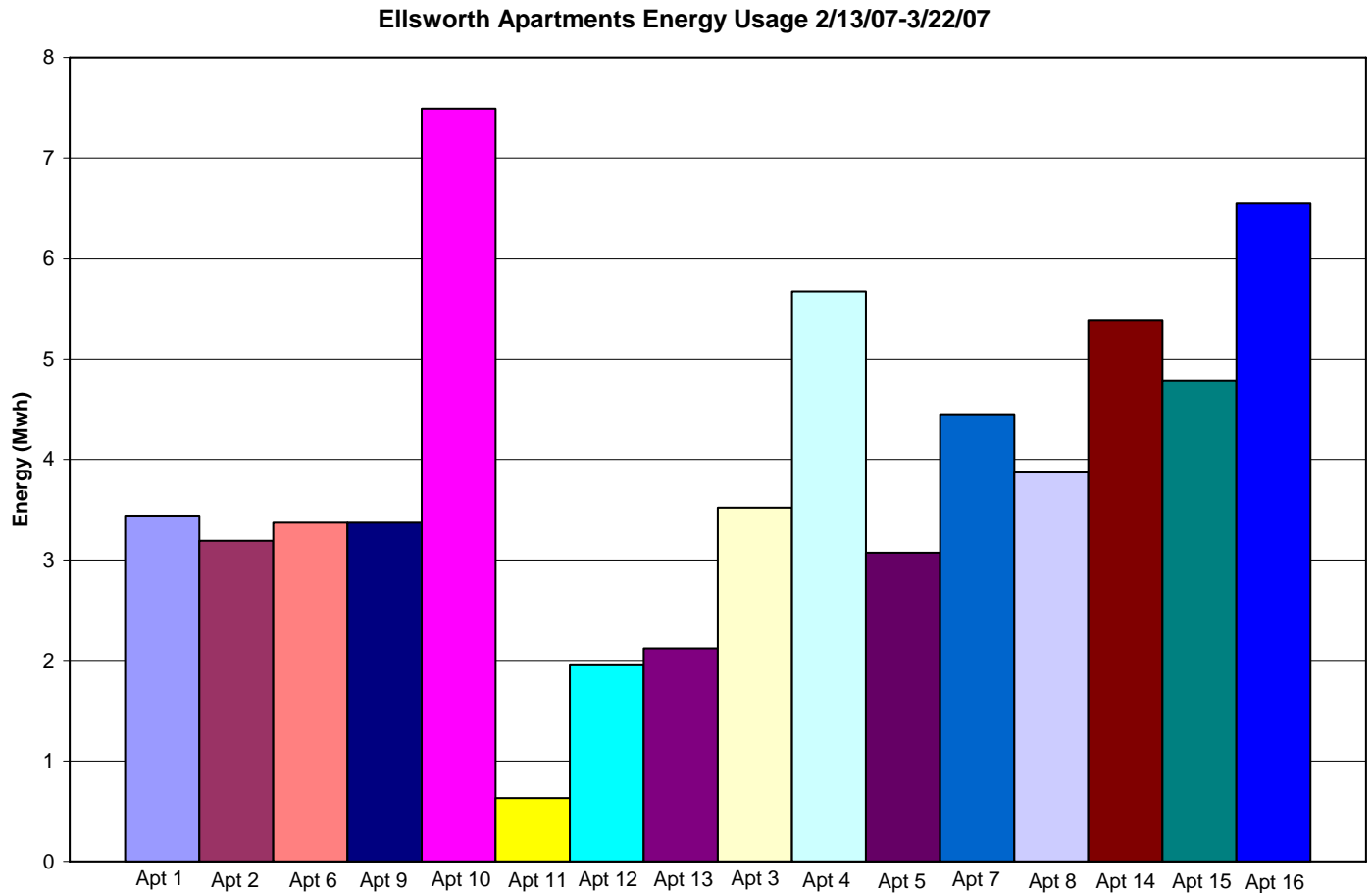

-Out of the 16 apartments there are 8 apartments with 5 students in them, 6 apartments with 7 students in them and there are 9 people in the office

## Appendix E: Map of WPI's Main Campus



Red Buildings: Meters not working  
Green Buildings: Meters work  
Orange Meter: Analog  
Blue Meter: Digital  
Black Meter: Digital and Analog

# Appendix F: Meter Status Report

## ***F.1 Electricity Meter Evaluation Legend***

<b><i>Building:</i></b>	The name of the building being evaluated
<b><i>Metered</i></b>	Is there a meter present? (functioning or not)
<b><i>Meter Running</i></b>	Does it appear to be functioning? (is meter disc rotating?)
<b><i>Multiplier Displayed</i></b>	Is the multiplier displayed? (yes if digital or if =1)
<b><i>Reasonable Data</i></b>	Does the data obtained from the meter appear to be reasonable?
<b><i>Meter Type</i></b>	Type of meter (analog or digital)
<b><i>Meter Manufacturer</i></b>	The manufacturer of the meter
<b><i>Meter Model</i></b>	The model of the meter (be as specific as possible)
<b><i>Meters Energy Usage</i></b>	Does the meter display a kW-hr reading or can one be obtained?
<b><i>Energy Meter Works</i></b>	Does it appear to be working?
<b><i>Meters Instantaneous Power</i></b>	Does the meter display an instantaneous power use reading?
<b><i>Instantaneous Power Meter Works</i></b>	Does it appear to be working?
<b><i>Meters Maximum Power Consumption</i></b>	Does the meter display a maximum power consumption reading?
<b><i>Maximum Power Meter Works</i></b>	Does it appear to be working?
<b><i>location</i></b>	A Description of the location of the meter
<b><i>comments</i></b>	Any additional information about the meter



## **F.2: Electricity Meter Inventory**

### ***Electricity Meter Evaluation***

***Building:*** Alden and Riley Hall

---

<b><i>Metered</i></b>	<input checked="" type="checkbox"/>
<b><i>Meter Running</i></b>	<input checked="" type="checkbox"/>
<b><i>Multiplier Displayed</i></b>	<input checked="" type="checkbox"/>
<b><i>Reasonable Data</i></b>	<input checked="" type="checkbox"/>
<b><i>Meter Type</i></b>	Digital
<b><i>Meter Manufacturer</i></b>	Siemens
<b><i>Meter Model</i></b>	4700 Digital Meter
<b><i>Meters Energy Usage</i></b>	<input checked="" type="checkbox"/>
<b><i>Energy Meter Works</i></b>	<input checked="" type="checkbox"/>
<b><i>Meters Instantaneous Power Consumption</i></b>	<input checked="" type="checkbox"/>
<b><i>Instantaneous Power Meter Works</i></b>	<input checked="" type="checkbox"/>
<b><i>Meters Maximum Power Consumption</i></b>	<input checked="" type="checkbox"/>
<b><i>Maximum Power Meter Works</i></b>	<input checked="" type="checkbox"/>

***location*** Basement of Alden Hall

***comments*** One meter serves both buildings

**Building:** Atwater Kent

---

<i>Metered</i>	<input checked="" type="checkbox"/>
<i>Meter Running</i>	<input type="checkbox"/>
<i>Multiplier Displayed</i>	<input checked="" type="checkbox"/>
<i>Reasonable Data</i>	<input type="checkbox"/>
<i>Meter Type</i>	Analog
<i>Meter Manufacturer</i>	GE
<i>Meter Model</i>	
<i>Meters Energy Usage</i>	<input checked="" type="checkbox"/>
<i>Energy Meter Works</i>	<input type="checkbox"/>
<i>Meters Instantaneous Power Consumption</i>	<input checked="" type="checkbox"/>
<i>Instantaneous Power Meter Works</i>	<input type="checkbox"/>
<i>Meters Maximum Power Consumption</i>	<input type="checkbox"/>
<i>Maximum Power Meter Works</i>	<input type="checkbox"/>

**location** 1st floor Atwater Kent electric room

**comments** Meter disconnected

**Building:** Campus Center

---

<i>Metered</i>	<input checked="" type="checkbox"/>
<i>Meter Running</i>	<input checked="" type="checkbox"/>
<i>Multiplier Displayed</i>	<input checked="" type="checkbox"/>
<i>Reasonable Data</i>	<input type="checkbox"/>
<i>Meter Type</i>	Digital
<i>Meter Manufacturer</i>	GE
<i>Meter Model</i>	Power Leader EPM
<i>Meters Energy Usage</i>	<input checked="" type="checkbox"/>
<i>Energy Meter Works</i>	<input checked="" type="checkbox"/>
<i>Meters Instantaneous Power Consumption</i>	<input checked="" type="checkbox"/>
<i>Instantaneous Power Meter Works</i>	<input checked="" type="checkbox"/>
<i>Meters Maximum Power Consumption</i>	<input checked="" type="checkbox"/>
<i>Maximum Power Meter Works</i>	<input checked="" type="checkbox"/>

*location* 1st floor electric room

*comments* Ambiguity in timescale



**Building:** Daniels and Morgan Residence Halls

---

<i>Metered</i>	<input checked="" type="checkbox"/>
<i>Meter Running</i>	<input checked="" type="checkbox"/>
<i>Multiplier Displayed</i>	<input checked="" type="checkbox"/>
<i>Reasonable Data</i>	<input checked="" type="checkbox"/>
<i>Meter Type</i>	Digital
<i>Meter Manufacturer</i>	Power Logic
<i>Meter Model</i>	
<i>Meters Energy Usage</i>	<input checked="" type="checkbox"/>
<i>Energy Meter Works</i>	<input checked="" type="checkbox"/>
<i>Meters Instantaneous Power Consumption</i>	<input checked="" type="checkbox"/>
<i>Instantaneous Power Meter Works</i>	<input checked="" type="checkbox"/>
<i>Meters Maximum Power Consumption</i>	<input checked="" type="checkbox"/>
<i>Maximum Power Meter Works</i>	<input checked="" type="checkbox"/>

*location* Basement of Daniels outside Plant Services

*comments* One meter serves both res halls

**Building:** Ellsworth Apartments (individual)

---

<i>Metered</i>	<input checked="" type="checkbox"/>
<i>Meter Running</i>	<input checked="" type="checkbox"/>
<i>Multiplier Displayed</i>	<input checked="" type="checkbox"/>
<i>Reasonable Data</i>	<input checked="" type="checkbox"/>
<i>Meter Type</i>	Analog
<i>Meter Manufacturer</i>	
<i>Meter Model</i>	
<i>Meters Energy Usage</i>	<input checked="" type="checkbox"/>
<i>Energy Meter Works</i>	<input checked="" type="checkbox"/>
<i>Meters Instantaneous Power Consumption</i>	<input type="checkbox"/>
<i>Instantaneous Power Meter Works</i>	<input type="checkbox"/>
<i>Meters Maximum Power Consumption</i>	<input type="checkbox"/>
<i>Maximum Power Meter Works</i>	<input type="checkbox"/>

*location* Basement of Ellsworth

*comments* Each apt. has a meter

**Building:** Ellsworth Apartments (main)

---

<i>Metered</i>	<input checked="" type="checkbox"/>
<i>Meter Running</i>	<input checked="" type="checkbox"/>
<i>Multiplier Displayed</i>	<input checked="" type="checkbox"/>
<i>Reasonable Data</i>	<input checked="" type="checkbox"/>
<i>Meter Type</i>	Analog
<i>Meter Manufacturer</i>	
<i>Meter Model</i>	
<i>Meters Energy Usage</i>	<input checked="" type="checkbox"/>
<i>Energy Meter Works</i>	<input checked="" type="checkbox"/>
<i>Meters Instantaneous Power Consumption</i>	<input checked="" type="checkbox"/>
<i>Instantaneous Power Meter Works</i>	<input checked="" type="checkbox"/>
<i>Meters Maximum Power Consumption</i>	<input type="checkbox"/>
<i>Maximum Power Meter Works</i>	<input type="checkbox"/>

*location* Basement of Ellsworth

*comments* Serves entire bldg

**Building:** Fuller Apartments (individual

---

<i>Metered</i>	<input checked="" type="checkbox"/>
<i>Meter Running</i>	<input checked="" type="checkbox"/>
<i>Multiplier Displayed</i>	<input checked="" type="checkbox"/>
<i>Reasonable Data</i>	<input checked="" type="checkbox"/>
<i>Meter Type</i>	Analog
<i>Meter Manufacturer</i>	
<i>Meter Model</i>	
<i>Meters Energy Usage</i>	<input checked="" type="checkbox"/>
<i>Energy Meter Works</i>	<input checked="" type="checkbox"/>
<i>Meters Instantaneous Power Consumption</i>	<input type="checkbox"/>
<i>Instantaneous Power Meter Works</i>	<input type="checkbox"/>
<i>Meters Maximum Power Consumption</i>	<input type="checkbox"/>
<i>Maximum Power Meter Works</i>	<input type="checkbox"/>

*location* Basement of Fuller apts

*comments* Each apt. has a meter



**Building:** Fuller Apartments (main)

---

<i>Metered</i>	<input checked="" type="checkbox"/>
<i>Meter Running</i>	<input checked="" type="checkbox"/>
<i>Multiplier Displayed</i>	<input checked="" type="checkbox"/>
<i>Reasonable Data</i>	<input checked="" type="checkbox"/>
<i>Meter Type</i>	Analog
<i>Meter Manufacturer</i>	
<i>Meter Model</i>	
<i>Meters Energy Usage</i>	<input checked="" type="checkbox"/>
<i>Energy Meter Works</i>	<input checked="" type="checkbox"/>
<i>Meters Instantaneous Power Consumption</i>	<input checked="" type="checkbox"/>
<i>Instantaneous Power Meter Works</i>	<input checked="" type="checkbox"/>
<i>Meters Maximum Power Consumption</i>	<input type="checkbox"/>
<i>Maximum Power Meter Works</i>	<input type="checkbox"/>

*location* Basement of Fuller apts.

*comments* Serves entire bldg

**Building:** Fuller Labs

---

<i>Metered</i>	<input checked="" type="checkbox"/>
<i>Meter Running</i>	<input checked="" type="checkbox"/>
<i>Multiplier Displayed</i>	<input type="checkbox"/>
<i>Reasonable Data</i>	<input type="checkbox"/>
<i>Meter Type</i>	Digital/Analog
<i>Meter Manufacturer</i>	GE
<i>Meter Model</i>	Electronic Register
<i>Meters Energy Usage</i>	<input checked="" type="checkbox"/>
<i>Energy Meter Works</i>	<input checked="" type="checkbox"/>
<i>Meters Instantaneous Power Consumption</i>	<input checked="" type="checkbox"/>
<i>Instantaneous Power Meter Works</i>	<input type="checkbox"/>
<i>Meters Maximum Power Consumption</i>	<input type="checkbox"/>
<i>Maximum Power Meter Works</i>	<input type="checkbox"/>

*location* 2nd floor electric room

*comments* Digital kwhr meter works, analog pwr mtr

**Building:** George C. Gordon Library

---

<i>Metered</i>	<input checked="" type="checkbox"/>
<i>Meter Running</i>	<input checked="" type="checkbox"/>
<i>Multiplier Displayed</i>	<input checked="" type="checkbox"/>
<i>Reasonable Data</i>	<input type="checkbox"/>
<i>Meter Type</i>	Analog
<i>Meter Manufacturer</i>	
<i>Meter Model</i>	DS485
<i>Meters Energy Usage</i>	<input checked="" type="checkbox"/>
<i>Energy Meter Works</i>	<input type="checkbox"/>
<i>Meters Instantaneous Power Consumption</i>	<input checked="" type="checkbox"/>
<i>Instantaneous Power Meter Works</i>	<input type="checkbox"/>
<i>Meters Maximum Power Consumption</i>	<input type="checkbox"/>
<i>Maximum Power Meter Works</i>	<input type="checkbox"/>

*location* Basement mechanical room

*comments* kw-hrs produce strange results

**Building:** Harrington Auditorium

---

<i>Metered</i>	<input checked="" type="checkbox"/>
<i>Meter Running</i>	<input checked="" type="checkbox"/>
<i>Multiplier Displayed</i>	<input checked="" type="checkbox"/>
<i>Reasonable Data</i>	<input checked="" type="checkbox"/>
<i>Meter Type</i>	Analog
<i>Meter Manufacturer</i>	
<i>Meter Model</i>	
<i>Meters Energy Usage</i>	<input checked="" type="checkbox"/>
<i>Energy Meter Works</i>	<input checked="" type="checkbox"/>
<i>Meters Instantaneous Power Consumption</i>	<input checked="" type="checkbox"/>
<i>Instantaneous Power Meter Works</i>	<input checked="" type="checkbox"/>
<i>Meters Maximum Power Consumption</i>	<input type="checkbox"/>
<i>Maximum Power Meter Works</i>	<input type="checkbox"/>

*location* Basement of Harrington

*comments* Dated equipment

Monday, May 21, 2007

Page 11 of 21

**Building:** Higgins Labs and Alumni

---

<i>Metered</i>	<input checked="" type="checkbox"/>
<i>Meter Running</i>	<input checked="" type="checkbox"/>
<i>Multiplier Displayed</i>	<input checked="" type="checkbox"/>
<i>Reasonable Data</i>	<input checked="" type="checkbox"/>
<i>Meter Type</i>	Digital
<i>Meter Manufacturer</i>	Power Logic
<i>Meter Model</i>	
<i>Meters Energy Usage</i>	<input checked="" type="checkbox"/>
<i>Energy Meter Works</i>	<input checked="" type="checkbox"/>
<i>Meters Instantaneous Power Consumption</i>	<input checked="" type="checkbox"/>
<i>Instantaneous Power Meter Works</i>	<input checked="" type="checkbox"/>
<i>Meters Maximum Power Consumption</i>	<input checked="" type="checkbox"/>
<i>Maximum Power Meter Works</i>	<input checked="" type="checkbox"/>

*location* Basement of HL on bldg transformer

*comments* Mtr integrated w/ pwr trnsfmr

**Building:** Kaven Hall

---

<i>Metered</i>	<input checked="" type="checkbox"/>
<i>Meter Running</i>	<input type="checkbox"/>
<i>Multiplier Displayed</i>	<input checked="" type="checkbox"/>
<i>Reasonable Data</i>	<input type="checkbox"/>
<i>Meter Type</i>	Analog
<i>Meter Manufacturer</i>	GE
<i>Meter Model</i>	
<i>Meters Energy Usage</i>	<input checked="" type="checkbox"/>
<i>Energy Meter Works</i>	<input type="checkbox"/>
<i>Meters Instantaneous Power Consumption</i>	<input checked="" type="checkbox"/>
<i>Instantaneous Power Meter Works</i>	<input type="checkbox"/>
<i>Meters Maximum Power Consumption</i>	<input type="checkbox"/>
<i>Maximum Power Meter Works</i>	<input type="checkbox"/>

*location* 1st floor Atwater Kent electric room

*comments* Meter disconnected

**Building:** Olin Hall

---

<i>Metered</i>	<input checked="" type="checkbox"/>
<i>Meter Running</i>	<input type="checkbox"/>
<i>Multiplier Displayed</i>	<input checked="" type="checkbox"/>
<i>Reasonable Data</i>	<input type="checkbox"/>
<i>Meter Type</i>	Analog
<i>Meter Manufacturer</i>	
<i>Meter Model</i>	
<i>Meters Energy Usage</i>	<input checked="" type="checkbox"/>
<i>Energy Meter Works</i>	<input type="checkbox"/>
<i>Meters Instantaneous Power Consumption</i>	<input checked="" type="checkbox"/>
<i>Instantaneous Power Meter Works</i>	<input type="checkbox"/>
<i>Meters Maximum Power Consumption</i>	<input type="checkbox"/>
<i>Maximum Power Meter Works</i>	<input type="checkbox"/>

*location* 1st floor electric room

*comments* Pwr needle buried

**Building:** Power House (wpi main)

---

<i>Metered</i>	<input checked="" type="checkbox"/>
<i>Meter Running</i>	<input checked="" type="checkbox"/>
<i>Multiplier Displayed</i>	<input checked="" type="checkbox"/>
<i>Reasonable Data</i>	<input checked="" type="checkbox"/>
<i>Meter Type</i>	Digital
<i>Meter Manufacturer</i>	Elster
<i>Meter Model</i>	ALK1+
<i>Meters Energy Usage</i>	<input checked="" type="checkbox"/>
<i>Energy Meter Works</i>	<input checked="" type="checkbox"/>
<i>Meters Instantaneous Power Consumption</i>	<input type="checkbox"/>
<i>Instantaneous Power Meter Works</i>	<input type="checkbox"/>
<i>Meters Maximum Power Consumption</i>	<input checked="" type="checkbox"/>
<i>Maximum Power Meter Works</i>	<input checked="" type="checkbox"/>

*location* Power House

*comments* Read by electric company



**Building:** Salisbury Labs

---

<i>Metered</i>	<input checked="" type="checkbox"/>
<i>Meter Running</i>	<input checked="" type="checkbox"/>
<i>Multiplier Displayed</i>	<input type="checkbox"/>
<i>Reasonable Data</i>	<input type="checkbox"/>
<i>Meter Type</i>	Analog
<i>Meter Manufacturer</i>	Westinghouse
<i>Meter Model</i>	
<i>Meters Energy Usage</i>	<input checked="" type="checkbox"/>
<i>Energy Meter Works</i>	<input checked="" type="checkbox"/>
<i>Meters Instantaneous Power Consumption</i>	<input checked="" type="checkbox"/>
<i>Instantaneous Power Meter Works</i>	<input checked="" type="checkbox"/>
<i>Meters Maximum Power Consumption</i>	<input type="checkbox"/>
<i>Maximum Power Meter Works</i>	<input type="checkbox"/>

*location* 1st floor electric room

*comments* No multiplier

**Building:** Stoddard A

---

<i>Metered</i>	<input checked="" type="checkbox"/>
<i>Meter Running</i>	<input checked="" type="checkbox"/>
<i>Multiplier Displayed</i>	<input checked="" type="checkbox"/>
<i>Reasonable Data</i>	<input type="checkbox"/>
<i>Meter Type</i>	Analog
<i>Meter Manufacturer</i>	Westinghouse
<i>Meter Model</i>	
<i>Meters Energy Usage</i>	<input checked="" type="checkbox"/>
<i>Energy Meter Works</i>	<input checked="" type="checkbox"/>
<i>Meters Instantaneous Power Consumption</i>	<input checked="" type="checkbox"/>
<i>Instantaneous Power Meter Works</i>	<input checked="" type="checkbox"/>
<i>Meters Maximum Power Consumption</i>	<input type="checkbox"/>
<i>Maximum Power Meter Works</i>	<input type="checkbox"/>

*location* Basement of Stoddard C

*comments* Total energy usage results are suspect: timescale?

**Building:** Stoddard B

---

<i>Metered</i>	<input checked="" type="checkbox"/>
<i>Meter Running</i>	<input checked="" type="checkbox"/>
<i>Multiplier Displayed</i>	<input checked="" type="checkbox"/>
<i>Reasonable Data</i>	<input type="checkbox"/>
<i>Meter Type</i>	Analog
<i>Meter Manufacturer</i>	Westinghouse
<i>Meter Model</i>	
<i>Meters Energy Usage</i>	<input checked="" type="checkbox"/>
<i>Energy Meter Works</i>	<input checked="" type="checkbox"/>
<i>Meters Instantaneous Power Consumption</i>	<input checked="" type="checkbox"/>
<i>Instantaneous Power Meter Works</i>	<input checked="" type="checkbox"/>
<i>Meters Maximum Power Consumption</i>	<input type="checkbox"/>
<i>Maximum Power Meter Works</i>	<input type="checkbox"/>

*location* Basement of Stoddard C

*comments* Total energy usage results are suspect: timescale?

**Building:** Stoddard C

---

<i>Metered</i>	<input checked="" type="checkbox"/>
<i>Meter Running</i>	<input checked="" type="checkbox"/>
<i>Multiplier Displayed</i>	<input checked="" type="checkbox"/>
<i>Reasonable Data</i>	<input type="checkbox"/>
<i>Meter Type</i>	Analog
<i>Meter Manufacturer</i>	Westinghouse
<i>Meter Model</i>	
<i>Meters Energy Usage</i>	<input checked="" type="checkbox"/>
<i>Energy Meter Works</i>	<input checked="" type="checkbox"/>
<i>Meters Instantaneous Power Consumption</i>	<input checked="" type="checkbox"/>
<i>Instantaneous Power Meter Works</i>	<input checked="" type="checkbox"/>
<i>Meters Maximum Power Consumption</i>	<input type="checkbox"/>
<i>Maximum Power Meter Works</i>	<input type="checkbox"/>

*location* Basement of Stoddard C

*comments* Total energy usage results are suspect: timescale?

**Building:** Stoddard snow melter

---

<i>Metered</i>	<input checked="" type="checkbox"/>
<i>Meter Running</i>	<input checked="" type="checkbox"/>
<i>Multiplier Displayed</i>	<input checked="" type="checkbox"/>
<i>Reasonable Data</i>	<input checked="" type="checkbox"/>
<i>Meter Type</i>	Analog
<i>Meter Manufacturer</i>	Westinghouse
<i>Meter Model</i>	
<i>Meters Energy Usage</i>	<input checked="" type="checkbox"/>
<i>Energy Meter Works</i>	<input checked="" type="checkbox"/>
<i>Meters Instantaneous Power Consumption</i>	<input type="checkbox"/>
<i>Instantaneous Power Meter Works</i>	<input type="checkbox"/>
<i>Meters Maximum Power Consumption</i>	<input type="checkbox"/>
<i>Maximum Power Meter Works</i>	<input type="checkbox"/>

**location** Basement of Stoddard C

**comments** Only have one value

**Building:** Washburn

---

- Metered*
- Meter Running*
- Multiplier Displayed*
- Reasonable Data*
- Meter Type* None
- Meter Manufacturer*
- Meter Model*
- Meters Energy Usage*
- Energy Meter Works*
- Meters Instantaneous Power Consumption*
- Instantaneous Power Meter Works*
- Meters Maximum Power Consumption*
- Maximum Power Meter Works*

*location*

*comments* No meter

### F.3: Meter Capabilities

#### *Meter Capabilities*

<i>Building</i>	<i>Meter can Display:</i>	<u><i>KW-hrs</i></u>	<u><i>Instantaneous Power Usage</i></u>	<u><i>Maximum Power Usage</i></u>
Campus Center		<input checked="" type="checkbox"/>	<input checked="" type="checkbox"/>	<input checked="" type="checkbox"/>
Olin Hall		<input checked="" type="checkbox"/>	<input checked="" type="checkbox"/>	<input type="checkbox"/>
Fuller Labs		<input checked="" type="checkbox"/>	<input checked="" type="checkbox"/>	<input type="checkbox"/>
George C. Gordon Library		<input checked="" type="checkbox"/>	<input checked="" type="checkbox"/>	<input type="checkbox"/>
Daniels and Morgan Residence		<input checked="" type="checkbox"/>	<input checked="" type="checkbox"/>	<input checked="" type="checkbox"/>
Stoddard A		<input checked="" type="checkbox"/>	<input checked="" type="checkbox"/>	<input type="checkbox"/>
Stoddard B		<input checked="" type="checkbox"/>	<input checked="" type="checkbox"/>	<input type="checkbox"/>
Stoddard C		<input checked="" type="checkbox"/>	<input checked="" type="checkbox"/>	<input type="checkbox"/>
Stoddard snow melter		<input checked="" type="checkbox"/>	<input type="checkbox"/>	<input type="checkbox"/>
Salisbury Labs		<input checked="" type="checkbox"/>	<input checked="" type="checkbox"/>	<input type="checkbox"/>
Atwater Kent		<input checked="" type="checkbox"/>	<input checked="" type="checkbox"/>	<input type="checkbox"/>
Kaven Hall		<input checked="" type="checkbox"/>	<input checked="" type="checkbox"/>	<input type="checkbox"/>
Power House (wpi main)		<input checked="" type="checkbox"/>	<input type="checkbox"/>	<input checked="" type="checkbox"/>
Alden and Riley Hall		<input checked="" type="checkbox"/>	<input checked="" type="checkbox"/>	<input checked="" type="checkbox"/>
Harrington Auditorium		<input checked="" type="checkbox"/>	<input checked="" type="checkbox"/>	<input type="checkbox"/>
Ellsworth Apartments (main)		<input checked="" type="checkbox"/>	<input checked="" type="checkbox"/>	<input type="checkbox"/>
Ellsworth Apartments (individua		<input checked="" type="checkbox"/>	<input type="checkbox"/>	<input type="checkbox"/>
Fuller Apartments (main)		<input checked="" type="checkbox"/>	<input checked="" type="checkbox"/>	<input type="checkbox"/>
Fuller Apartments (individual		<input checked="" type="checkbox"/>	<input type="checkbox"/>	<input type="checkbox"/>
Washburn		<input type="checkbox"/>	<input type="checkbox"/>	<input type="checkbox"/>
Higgins Labs and Alumni		<input checked="" type="checkbox"/>	<input checked="" type="checkbox"/>	<input checked="" type="checkbox"/>

## **F.4: Energy Meter Data Quality**

### ***Energy Meter Data Quality***

<b><u>Building</u></b>	<b><u>Reasonable Reading</u></b>
Campus Center	<input type="checkbox"/>
Olin Hall	<input type="checkbox"/>
Fuller Labs	<input type="checkbox"/>
George C. Gordon Library	<input type="checkbox"/>
Daniels and Morgan Residence	<input checked="" type="checkbox"/>
Stoddard A	<input type="checkbox"/>
Stoddard B	<input type="checkbox"/>
Stoddard C	<input type="checkbox"/>
Stoddard snow melter	<input checked="" type="checkbox"/>
Salisbury Labs	<input type="checkbox"/>
Atwater Kent	<input type="checkbox"/>
Kaven Hall	<input type="checkbox"/>
Power House (wpi main)	<input checked="" type="checkbox"/>
Alden and Riley Hall	<input checked="" type="checkbox"/>
Harrington Auditorium	<input checked="" type="checkbox"/>
Ellsworth Apartments (main)	<input checked="" type="checkbox"/>
Ellsworth Apartments (individua	<input checked="" type="checkbox"/>
Fuller Apartments (main)	<input checked="" type="checkbox"/>
Fuller Apartments (individual	<input checked="" type="checkbox"/>
Washburn	<input type="checkbox"/>
Higgins Labs and Alumni	<input checked="" type="checkbox"/>



## F.5: Meter Functionality

### *Meter Functionality*

<i>Building</i>	<i>Metered</i>	<i>Meter Running</i>	<i>Multiplier Displayed</i>	<i>Functioning Readings for:</i>		
				<i>KW-hrs</i>	<i>Istantaneous Power Usage</i>	<i>Maximum Power Usage</i>
Campus Center	<input checked="" type="checkbox"/>	<input checked="" type="checkbox"/>	<input checked="" type="checkbox"/>	<input checked="" type="checkbox"/>	<input checked="" type="checkbox"/>	<input checked="" type="checkbox"/>
Olin Hall	<input checked="" type="checkbox"/>	<input type="checkbox"/>	<input checked="" type="checkbox"/>	<input type="checkbox"/>	<input type="checkbox"/>	<input type="checkbox"/>
Fuller Labs	<input checked="" type="checkbox"/>	<input checked="" type="checkbox"/>	<input type="checkbox"/>	<input checked="" type="checkbox"/>	<input type="checkbox"/>	<input type="checkbox"/>
George C. Gordon Library	<input checked="" type="checkbox"/>	<input checked="" type="checkbox"/>	<input checked="" type="checkbox"/>	<input type="checkbox"/>	<input type="checkbox"/>	<input type="checkbox"/>
Daniels and Morgan Residence	<input checked="" type="checkbox"/>	<input checked="" type="checkbox"/>	<input checked="" type="checkbox"/>	<input checked="" type="checkbox"/>	<input checked="" type="checkbox"/>	<input checked="" type="checkbox"/>
Stoddard A	<input checked="" type="checkbox"/>	<input checked="" type="checkbox"/>	<input checked="" type="checkbox"/>	<input checked="" type="checkbox"/>	<input checked="" type="checkbox"/>	<input type="checkbox"/>
Stoddard B	<input checked="" type="checkbox"/>	<input checked="" type="checkbox"/>	<input checked="" type="checkbox"/>	<input checked="" type="checkbox"/>	<input checked="" type="checkbox"/>	<input type="checkbox"/>
Stoddard C	<input checked="" type="checkbox"/>	<input checked="" type="checkbox"/>	<input checked="" type="checkbox"/>	<input checked="" type="checkbox"/>	<input checked="" type="checkbox"/>	<input type="checkbox"/>
Stoddard snow melter	<input checked="" type="checkbox"/>	<input checked="" type="checkbox"/>	<input checked="" type="checkbox"/>	<input checked="" type="checkbox"/>	<input type="checkbox"/>	<input type="checkbox"/>
Salisbury Labs	<input checked="" type="checkbox"/>	<input checked="" type="checkbox"/>	<input type="checkbox"/>	<input checked="" type="checkbox"/>	<input checked="" type="checkbox"/>	<input type="checkbox"/>
Atwater Kent	<input checked="" type="checkbox"/>	<input type="checkbox"/>	<input checked="" type="checkbox"/>	<input type="checkbox"/>	<input type="checkbox"/>	<input type="checkbox"/>
Kaven Hall	<input checked="" type="checkbox"/>	<input type="checkbox"/>	<input checked="" type="checkbox"/>	<input type="checkbox"/>	<input type="checkbox"/>	<input type="checkbox"/>
Power House (wpi main)	<input checked="" type="checkbox"/>	<input checked="" type="checkbox"/>	<input checked="" type="checkbox"/>	<input checked="" type="checkbox"/>	<input type="checkbox"/>	<input checked="" type="checkbox"/>
Alden and Riley Hall	<input checked="" type="checkbox"/>	<input checked="" type="checkbox"/>	<input checked="" type="checkbox"/>	<input checked="" type="checkbox"/>	<input checked="" type="checkbox"/>	<input checked="" type="checkbox"/>
Harrington Auditorium	<input checked="" type="checkbox"/>	<input checked="" type="checkbox"/>	<input checked="" type="checkbox"/>	<input checked="" type="checkbox"/>	<input checked="" type="checkbox"/>	<input type="checkbox"/>
Ellsworth Apartments (main)	<input checked="" type="checkbox"/>	<input checked="" type="checkbox"/>	<input checked="" type="checkbox"/>	<input checked="" type="checkbox"/>	<input checked="" type="checkbox"/>	<input type="checkbox"/>
Ellsworth Apartments (individua	<input checked="" type="checkbox"/>	<input checked="" type="checkbox"/>	<input checked="" type="checkbox"/>	<input checked="" type="checkbox"/>	<input type="checkbox"/>	<input type="checkbox"/>
Fuller Apartments (main)	<input checked="" type="checkbox"/>	<input checked="" type="checkbox"/>	<input checked="" type="checkbox"/>	<input checked="" type="checkbox"/>	<input checked="" type="checkbox"/>	<input type="checkbox"/>
Fuller Apartments (individual	<input checked="" type="checkbox"/>	<input checked="" type="checkbox"/>	<input checked="" type="checkbox"/>	<input checked="" type="checkbox"/>	<input type="checkbox"/>	<input type="checkbox"/>
Washburn	<input type="checkbox"/>	<input type="checkbox"/>	<input type="checkbox"/>	<input type="checkbox"/>	<input type="checkbox"/>	<input type="checkbox"/>
Higgins Labs and Alumni	<input checked="" type="checkbox"/>	<input checked="" type="checkbox"/>	<input checked="" type="checkbox"/>	<input checked="" type="checkbox"/>	<input checked="" type="checkbox"/>	<input checked="" type="checkbox"/>

Monday, May 21, 2007



MA Electric Switching Cabinet on West Street

EAST CAMPUS - Substation Located at North Side of Gordon Library

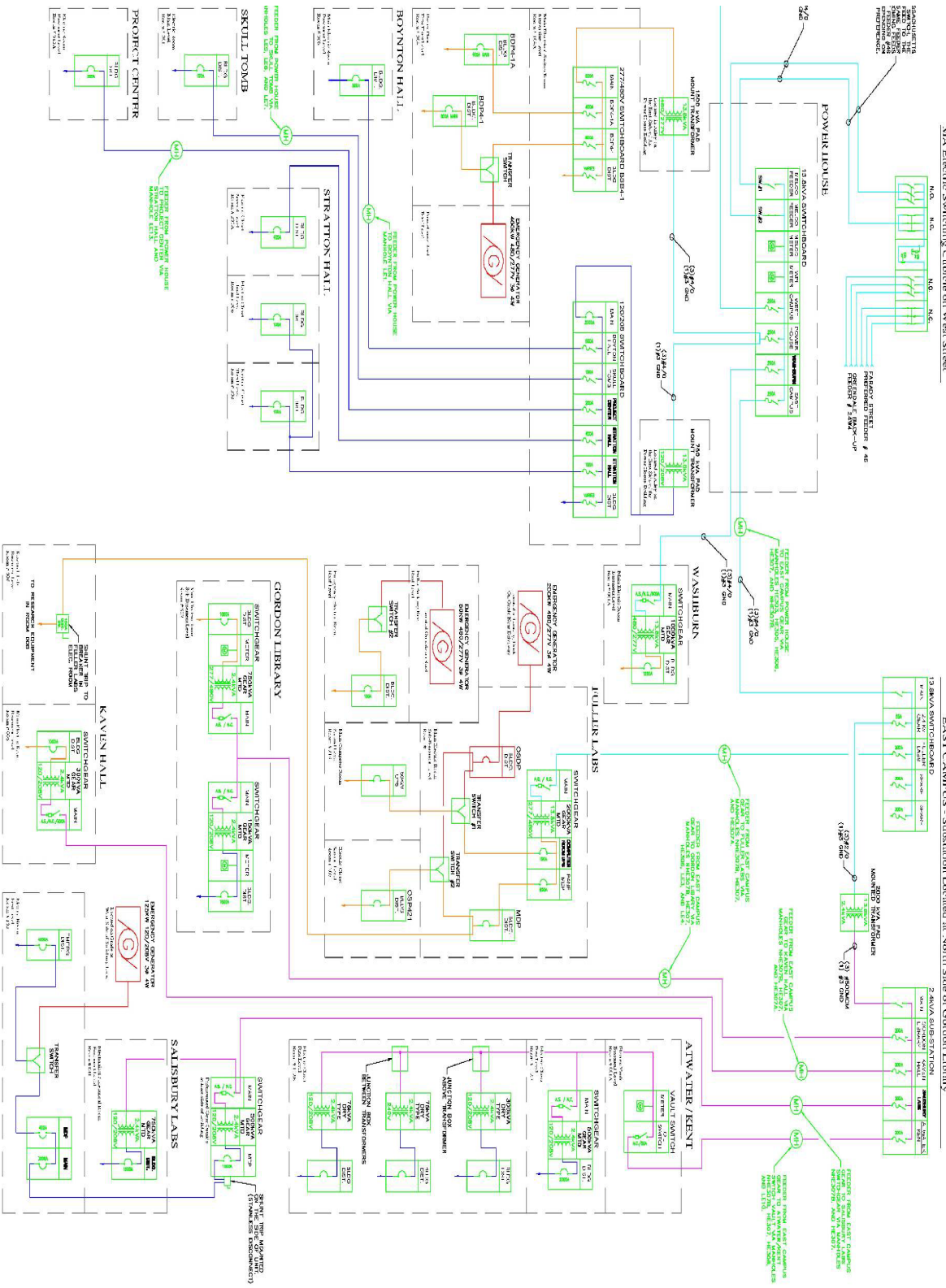

1	001-251-2106	MAINTENANCE	MAINTENANCE
2	112-2208	MAINTENANCE	MAINTENANCE
3	112-2208	MAINTENANCE	MAINTENANCE

1	001-251-2106	MAINTENANCE	MAINTENANCE
2	112-2208	MAINTENANCE	MAINTENANCE
3	112-2208	MAINTENANCE	MAINTENANCE

**Worcester Electrical Contractors, Inc.**  
 13 BAWA SWITCHBOARD  
 1200 VOLT BUS  
 MAINTENANCE

**Worcester Polytechnic Institute**  
 13 BAWA SWITCHBOARD  
 1200 VOLT BUS  
 MAINTENANCE

**Worcester Polytechnic Institute**  
 13 BAWA SWITCHBOARD  
 1200 VOLT BUS  
 MAINTENANCE

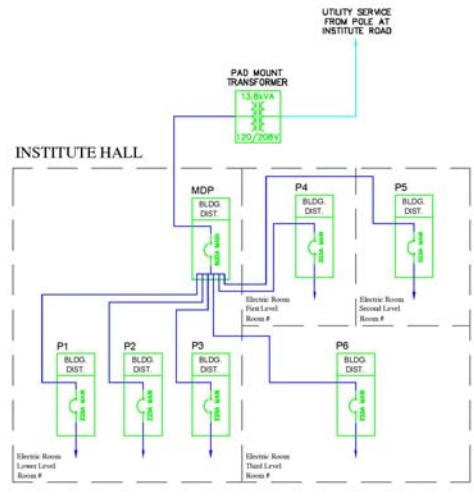
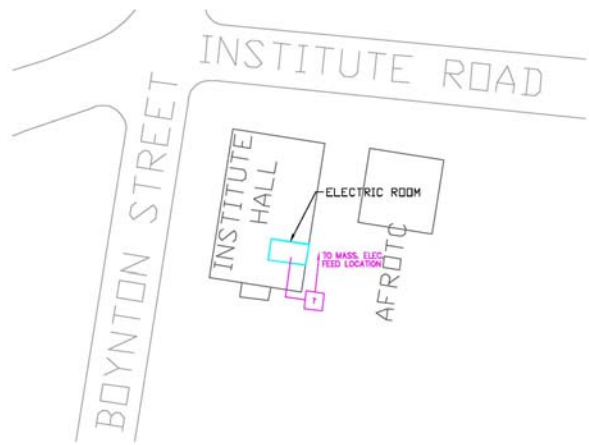

1 ELECTRICAL SERVICES FOR INSTITUTE HALL  
SCALE: N.T.S.

PAD MOUNT TRANSFORMER

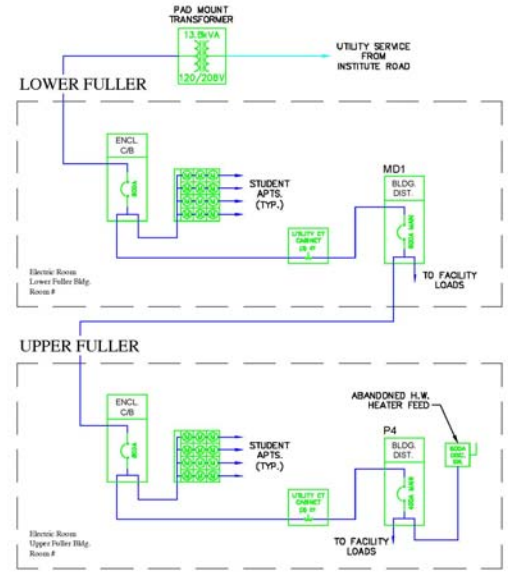
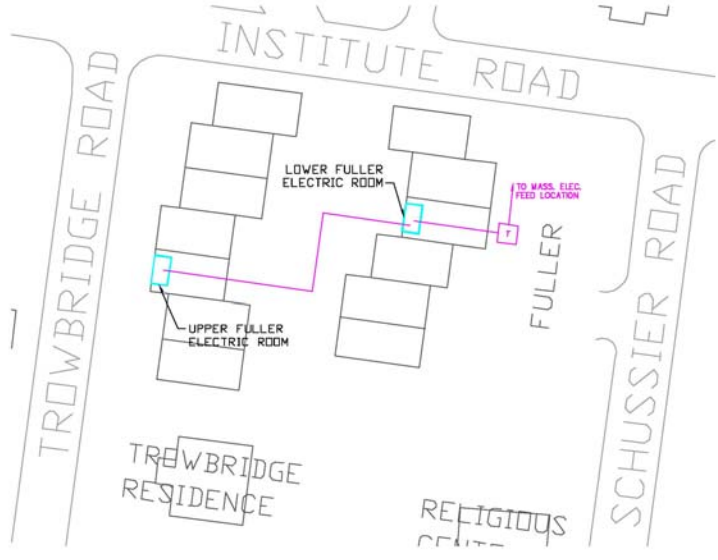

3 ELECTRICAL SERVICES FOR FULLER COMPLEX  
SCALE: N.T.S.

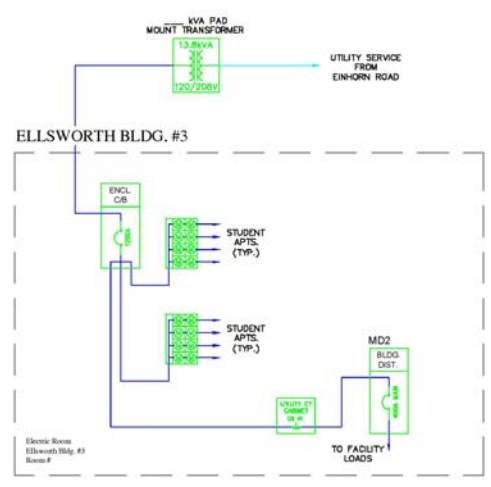
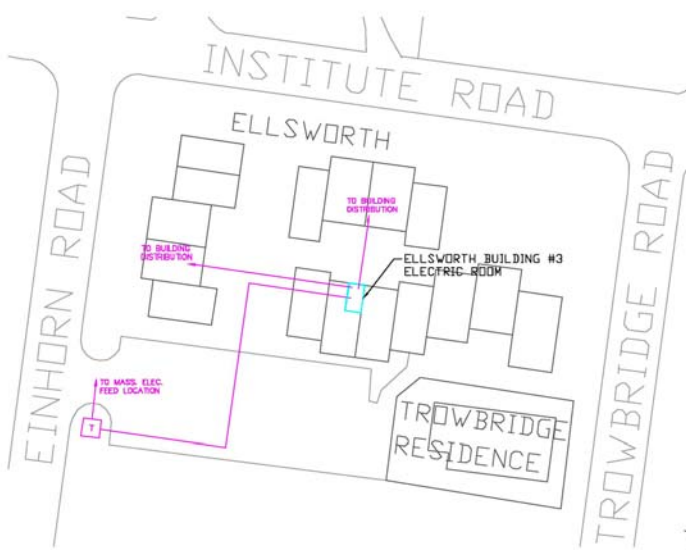

4 ELECTRICAL SERVICES FOR ELLSWORTH COMPLEX  
SCALE: N.T.S.

**General Notes:**

13.8Kv -	
277/480V -	
120/208V -	
EMG. GEN. -	

15k, Drawing & Materials  
Team in Possession of  
Copyright Electrical Contractors

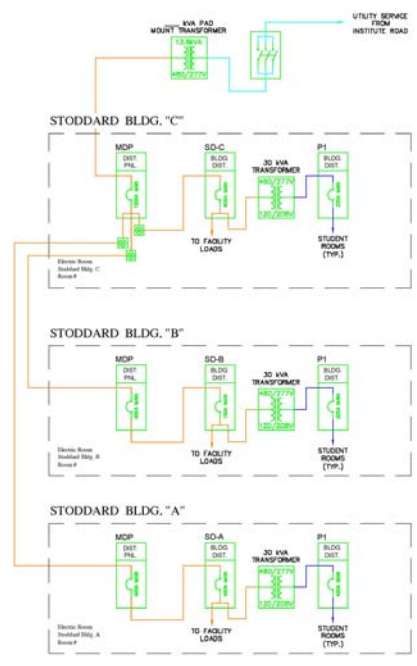
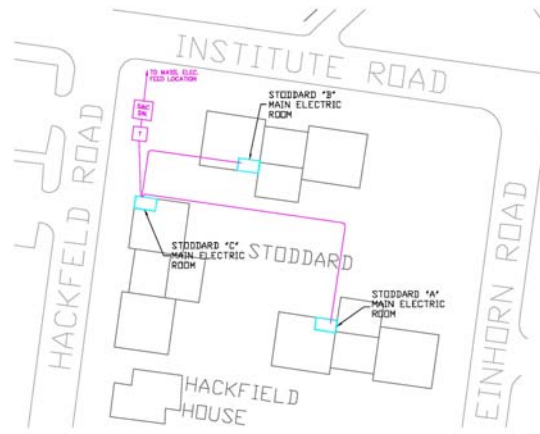

5 ELECTRICAL SERVICES FOR STODDARD COMPLEX  
SCALE: N.T.S.

1 03.25.06 BILLED FOR RECEIVED MVE 0 02.10.06 REVIEW OF SITE SERVICES MVE No. Date Revision By	 <b>ELECTRICAL CONTRACTORS, INC.</b> 100 PRESCOTT STREET WORCESTER, MA 01105 TEL (508) 799-0300 FAX (508) 799-0303 MA LIC. #4112003	 <b>WORCESTER POLYTECHNIC INSTITUTE</b> WPI Auxiliary Buildings Distribution and Equipment Plan	Project Number: <b>R6037</b> Date: <b>AS NOTED</b> Date: <b>03.11.98</b> City: <b>MAS</b>	Revision Number: <b>SITE E-02</b>
			Reference: <b>03-01-014-000</b>	

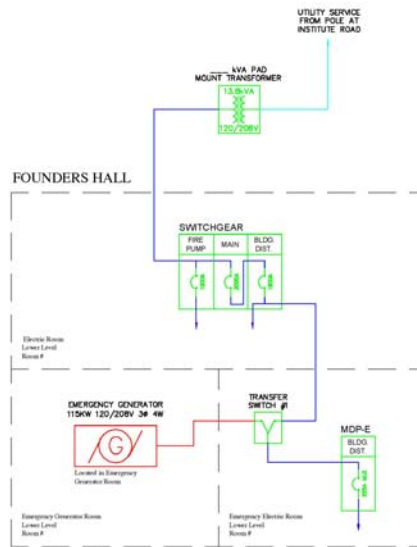
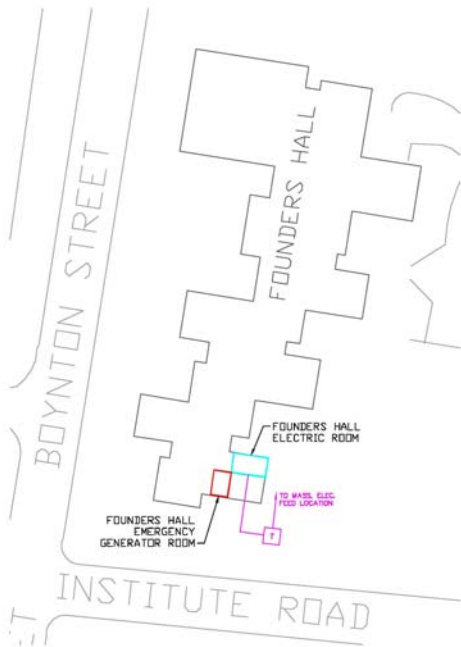

2 ELECTRICAL SERVICES FOR FOUNDERS HALL  
SCALE: N.T.S.