

AUTOMATIC ASH REMOVAL SYSTEM

A Major Qualifying Project Report

Submitted to the Faculty

of the

WORCESTER POLYTECHNIC INSTITUTE

in partial fulfillment of the requirements for the

Degree of Bachelor of Science

in Mechanical Engineering

by

Charles Dresser

and

Alexander Quinn

April 27, 2011

Approved:

Professor Isa Bar-On, Advisor

Professor Simon Evans, Advisor

Professor Richard D. Sisson, Jr.

Mechanical Engineering Department, WPI

Abstract

In order to encourage a transition from oil to wood pellet heating in Maine homes, Maine Energy Systems desires that an automated ash removal system be designed for their wood pellet boilers. This project employs the use of both traditional and axiomatic design methods to develop an ash removal system for the MESys 6000c wood pellet boiler. Two solutions were developed for Maine Energy Systems using various design techniques. These solutions were prototyped, tested, and revised, resulting in recommendations made to Maine Energy Systems.

Acknowledgements

We would like to thank our Faculty Advisors Professor Isa Bar-On and Professor Simon Evans for their guidance in our work on this Major Qualifying Project. Also Professor Chris Brown for his assistance in the design process, and Michael Fagan for his aid in the fabrication of our prototypes. We would also like to thank Maine Energy Systems for providing us with the means to accomplish this project.

Table of Contents

Abstract.....	i
Acknowledgements.....	ii
Table of Contents.....	iii
Authorship.....	iv
List of Figures.....	v
List of Tables.....	vi
List of Equations.....	vi
1.0 Introduction.....	1
2.0 Background.....	2
2.1 Wood Pellet Heating.....	2
2.2 Maine Energy Systems.....	3
2.2.1 MESys 6000c Pellet Boiler.....	4
2.3 Ash Removal.....	6
2.4 Design Approach.....	7
2.4.1 Axiomatic Design.....	7
2.4.2 Conventional Design.....	8
3.0 Design Methodology.....	11
3.1 Design.....	11
3.1.1 Design Requirements.....	11
3.1.2 Axiomatic Design.....	11
3.1.3 Conventional Design.....	15
3.1.4 Selection.....	19
3.1.5 Selection Results.....	20
3.2 Further Design.....	22
3.2.1 Auger System.....	23
3.2.2 Vacuum System.....	25
4.0 Prototyping and Testing.....	34
4.1 Prototyping.....	34
4.2 Test Criteria.....	35
4.3 Testing Results.....	36
4.3.1 Auger Test Results.....	36
4.3.2 Vacuum/Cyclone Test Results.....	37
5.0 Design Revisions.....	39
5.1 Auger System Revisions.....	39
5.2 Vacuum/Cyclone System Revisions.....	42
6.0 Conclusions.....	45
7.0 Recommendations.....	46
References.....	48

Authorship

All sections were written and edited by both team members. Primary authorship is as follows.

1.0	Introduction.....	CD
2.0	Background	
2.1	Wood Pellet Heating.....	CD
2.2	Maine Energy Systems.....	AQ
2.2.1	MESys 6000c Pellet Boiler.....	CD
2.3	Ash Removal.....	CD AQ
2.4	Design Approach	
2.4.1	Axiomatic Design.....	CD
2.4.2	Conventional Design.....	AQ
3.0	Design Methodology	
3.1	Design	
3.1.1	Design Requirements.....	AQ
3.1.2	Axiomatic Design.....	CD
3.1.3	Conventional Design.....	AQ
3.1.4	Selection.....	AQ
3.1.5	Selection Results.....	CD AQ
3.2	Further Design	
3.2.1	Auger System.....	CD AQ
3.2.2	Vacuum System.....	CD AQ
4.0	Prototyping and Testing	
4.1	Prototyping.....	AQ
4.2	Test Criteria.....	AQ
4.3	Testing Results	
4.3.1	Auger Test Results.....	CD
4.3.2	Vacuum/Cyclone Test Results.....	CD
5.0	Design Revisions	
5.1	Auger System Revisions.....	CD AQ
5.2	Vacuum/Cyclone System Revisions.....	CD AQ
6.0	Conclusions.....	CD
7.0	Recommendations.....	CD

List of Figures

Chapter 2

Figure 2.1: Example Pellet Heater Assembly	2
Figure 2.2: MESys 6000c Boiler	4
Figure 2.3: Janfire NH Wood Pellet Burner	5
Figure 2.4: Burner Bowl Scrape Cycle	5

Chapter 3

Figure 3.1: Axiomatic Design Matrix	14
Figure 3.2: Ökofen Automatic Ash Removal Solution	16
Figure 3.3: Kozlusan Ash Removal System	16
Figure 3.4a: Cyclone System	22
Figure 3.4b: Auger System	22
Figure 3.5: Initial Auger System Design	24
Figure 3.6: Cross Section of Auger System	25
Figure 3.7: AC Gear Motor	25
Figure 3.8: Schematic of Basic Cyclone	26
Figure 3.9: Critical Cyclone Dimensions	27
Figure 3.10: Vacuum Pump	28
Figure 3.11: TDRHL500l Specifications	29
Figure 3.12: Initial Cyclone System Design	31
Figure 3.13: Sloped Walls	32
Figure 3.14: Cyclonic Separator	32

Chapter 4

Figure 4.1: Auger Prototype	34
Figure 4.2: Cyclone System Prototype	35

Chapter 5

Figure 5.1: Auger System Design	39
Figure 5.2: Ash Gathering Component	40
Figure 5.3: Cross Section View of Auger	41
Figure 5.4: Bin Support and Ash Compartment Door	41
Figure 5.5: Ash Removal Bin	42
Figure 5.6: Multiple Cyclone System	43
Figure 5.7: Janfire Burner Bowl	44

List of Tables

Chapter 3

Table 3.1: Functional Requirements of the Ash Removal System	12
Table 3.2: Functional Requirement 1 Decomposition	12
Table 3.3: Functional Requirement 2	13
Table 3.4: Functional Requirements 3 Decomposition	13
Table 3.5: Design Decision Matrix	19
Table 3.6: Results of Decision Matrix	20
Table 3.7: Axiomatic Design Matrix for Auger System	21
Table 3.8: Axiomatic Design Matrix for Vacuum System	21

List of Equations

Chapter 3

Equation 3.1	23
Equation 3.2	23
Equation 3.3	23
Equation 3.4	24
Equation 3.5	19
Equation 3.6	30
Equation 3.7	30
Equation 3.8	30

1.0 Introduction

The aim of this project is to create an automated ash removal system for a wood pellet boiler through the use of axiomatic and conventional design methods. The project involves an engineering solution as well as an investigation of different design processes and various techniques. By approaching the design problem using different methods we benefit from the advantages of both axiomatic and conventional design.

The project is done for Maine Energy Systems (MESys), a wood pellet company that is currently prototyping a new pellet boiler. This boiler model does not contain a system for automatically removing the ash created during operation, a feature seen in many other boilers. The addition of an automated ash removal system is intended to make the boiler a more attractive heating option for both homes and businesses.

MESys hopes to make their new product, the 6000c boiler, an affordable heating solution that will help promote the use of wood pellets as an alternative to oil heating in the Northeastern United States. Wood is a natural and renewable fuel source that can be a less expensive and more stable alternative to heating with nonrenewable fuels such as oil. Pellets can be made directly from lumber or from wood industry waste and many wood pellet producers use a combination of round wood and waste wood byproducts in making wood pellets.¹

The application of different design methods in the completion of this project will allow the design to benefit from each, as well as provide an investigation into the differences and similarities of the design paradigms. The project will showcase the design process for both conventional and axiomatic design methods as they are applied to the design of an automated ash removal system.

2.0 Background

2.1 Wood Pellet Heating

Wood pellet heating can be used as a central heating solution for homes and businesses. Biofuels in the form of compressed natural wood fiber pellets are fed into a burner where they are ignited and burned, releasing energy used for central home heating, water heating, and other applications. Wood pellet heating has gained popularity in Europe in the last 10 years to the point where nearly all of the new homes being built in Upper Austria are being heated with wood pellets.² There has been little interest in wood pellet heating in the Northeast United States in the past. More than 80% of all Maine homes are currently heated with heating oil³, and 65% of household energy use is attributable to heating.⁴ Maine Energy Systems expects that this will change, predicting that more people will become interested in heating primarily with wood pellets as the economical, environmental and social costs of oil use become more widely understood by the public.⁵

Pellet heating systems consist of a storage bin, burner, boiler or furnace and in some systems an ash removal system. An example heating system is shown below in Figure 2.1.

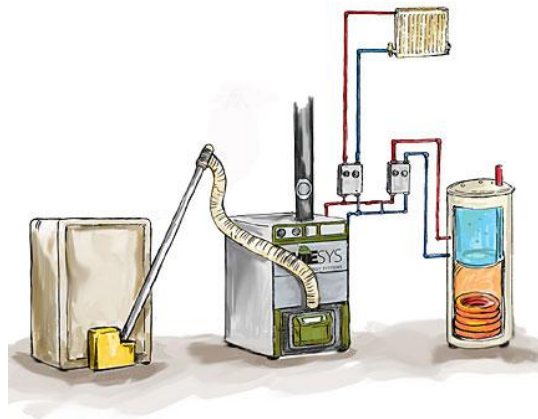

Figure 2.1: Example Pellet Heater Assembly⁶

A large amount of pellets is kept in the storage bin (far left in Figure 2.1 above), and transported to the burner by an auger or vacuum when needed. Pellets are fed into the burner either automatically or at a manually set rate depending on heating demands. The ash from the burnt pellets falls from the burner into the bottom of the boiler (middle in the figure above). Heat from the combustion of pellets is applied to a heating load, which can be central heat, hot water,

or other heating needs. Some systems automatically collect and store the ash, while others require manual cleaning and ash removal.

Pellet heating is a viable option for many regions of the United States containing underutilized working forests. According to the Maine Forest Service, over 7 million tons of wood of a quality needed to make premium grade pellets can be removed sustainably from northeastern forests each year, in addition to the current annual reported harvest.⁷ Wood is a natural and renewable fuel source that is currently a less expensive and more stable alternative to heating with nonrenewable fuels such as oil⁸. In addition, the combustion of wood releases fewer and less harmful emissions than fossil fuel, making it a greener heating option.

2.2 Maine Energy Systems

Maine Energy Systems (MESys) deals in the production and distribution of pellet heating systems. MESys distributes boilers licensed by BOSCH and the Austrian Manufacturer Ökofen. The company aims to facilitate a movement away from the use of fossil fuels for heating. The company mission is to “support a transition to the use of renewable wood pellet fuel for heating of homes and businesses...This fuel transition will not only lower costs for users in the long run, it will also help retain and create jobs in the region while significantly reducing the region’s carbon footprint.”⁹ The company helps in this transition by supplying and installing boilers as well as pellets.

MESys is currently prototyping the new 6000c boiler, which is intended to be less expensive than the foreign alternatives. It is the hope of Maine Energy Systems that the lower cost boiler will allow home and business owners to consider heating with wood pellets, where they previously may not have been able to afford the transition. Although there are many reasons to use wood pellet heating, it is the expectation of Maine Energy Systems that finances will be the most important factor in the transition from oil to wood pellet heating for most businesses and home owners. A specific consideration is the amount of time it takes for the savings from heating with wood pellets versus the conventional fuel to equal the initial cost of the wood pellet heating system, or the payback period.¹⁰ It is also expected that most home owners and businesses will look to transition to wood pellets when the cost of having a new wood pellet boiler installed and the cost of heating with wood pellets is substantially less than continuing to heat with their current heating fuel.

"The potential market for pellet central heating in the US Northeast is very large. It will mature as public awareness grows and as automatic entry-level boiler systems are prepared for the market at prices lower than those common for finely crafted European models. Maine Energy Systems is working on development of a relatively simple 25KW system that will list for less than \$9,000 putting it on a par with oil boilers of similar quality."

–Dutch Dresser, Maine Energy Systems

2.2.1 MESys 6000c Pellet Boiler

The aforementioned MESys 6000c pellet boiler is shown below in Figure 2.2. This model is expected to become available for purchase in the Fall of 2011.



Figure 2.2: MESys 6000c Boiler

The boiler contains a water jacket that encompasses the flame tube region (inside the boiler, near the top center) and surrounds the combustion chamber and the legs of the boiler all the way to the floor. Maintenance doors (the bottom left of Figure 2.2 above) must be used to access ash from the lower part of the boiler. Accessing ash from any other point will necessitate modifications to be made in the water jacket which would require the boiler to be recertified by the American Society of Mechanical Engineers (ASME). Currently, ash collects in the base of the boiler where there is a space (about 4.6 cubic feet) left for it to gather and be manually removed. The boiler has a 2' by 2' base with a height of about 4', with an ash door on either side of the lower section, as seen in Figure 2.2 above.

The 6000c boiler contains a Janfire NH burner unit, which is connected through the opening in the right side of the boiler in Figure 2.2. The NH Janfire burner is shown below in Figure 2.3. Pellets enter the burner at the top from a pellet hopper via a feed auger and are burned according to heating demand. The Janfire burner runs very efficiently with no need for user input other than to ensure that the four-ton pellet hopper is full. The Janfire burner is able to operate with a high level of efficiency because of energy modulation controlled through PID logic, allowing it to output heat at eleven ranges between 23kW and 0.6kW, based on previous output and current water and exterior temperatures.¹¹



Figure 2.3: Janfire NH Wood Pellet Burner¹²

Another noteworthy function of the Janfire burner is the ash-scrape cycle, which runs automatically after a predetermined amount of pellets has been burned. This process removes built-up ash from the bottom of the burner bowl, allowing it to fall into the bottom of the boiler. Figure 2.4 shows an image of the burner bowl. Once a certain amount of pellets has been combusted, the bottom of the bowl is opened and ash falls through.



Figure 2.4: Burner Bowl Scrape Cycle¹³

As a safety consideration the burner is allowed to cool before each ash scrape cycle, so the burner must pause each time the ash scrape cycle occurs. Each ash-scrape cycle takes about twenty minutes to complete.¹⁴ Although this function is already designed and is part of the current Janfire Burner, it will be included in our design of the ash removal system as it pertains to the removal of ash from a surface.

While the 6000c will offer hands free operation of the pellet feeding system, it currently requires periodic cleaning and ash removal by the homeowner. Many European boilers (including the imported Austrian unit distributed by MESys) remove ash automatically, greatly reducing the amount of time and effort the homeowner needs to invest in the heating system. This is a preferred alternative to the current emptying process for the 6000c, which requires that the ash door be unbolted, and that the user manually scrap ash from the lower compartment into a receptacle.

2.3 Ash Removal

Many advanced wood pellets boilers (mostly foreign models) are equipped with an automatic ash removal system. An ash removal system collects ash from burnt pellets and removes it from the boiler so that it does not adversely affect boiler performance, and also may be easily disposed of by the user. Some systems also compress the ash so that it takes up less space and can be disposed of with less frequency. Ökofen boilers can be purchased with or without automatic ash removal, but the BOSCH boilers being sold by MESYS as well as the new 6000C currently do not have ash removal systems, and on average require manual ash removal about every three weeks in the winter.

The Austrian company Froling and the Turkish company Kozlusan both offer pellet boilers with built-in automated ash removal systems. Although most fully automated ash removal systems use an auger to transport and often compress ash to a storage bin, some systems offer a lesser degree of automation by simply having a removable bin in the bottom of the boiler, which can be emptied as needed by the user. More on existing ash removal systems can be found in section 3.1.3 on Conventional Design.

The addition of an ash removal system is intended to make the 6000c much more attractive to potential owners by eliminating the need for manual handling and cleaning of ash. Nearly all of the Ökofen boilers sold by MESys are ordered with the ash removal system

installed.¹⁵ Allowing for hands free maintenance of an inexpensive wood pellet boiler is expected to increase the number of people who will find wood pellet heating a viable solution for their heating needs, aiding in the transition to a new sustainable energy source.

2.4 Design Approach

Both axiomatic and conventional design methods were used to create an ash removal system. The design principles and steps of both approaches were compared and contrasted, as were the solutions resulting from each. This was done both as an investigation into the similarities and differences of both methods, as well as to achieve a final design from both.

2.4.1 Axiomatic Design

Axiomatic design (AD) makes use of design axioms which lead to the best possible design of a system.¹⁶ Through fully understanding the requirements of the intended operator of the system and by making use of axiomatic design principles, it is expected that a robust and overall successful solution will be realized. Within AD methodology the components of a design are decomposed into the base functions that the design must accomplish. By addressing each function separately one is able to design so that separate aspects of the design do not interfere with one another.

AD principles require minimizing the number of functions the design will execute and interactions between the functions of the design. The functions within the larger decomposition may require other functions to be completed; in AD these functions are considered children of the first, or “parent” function.

Design decomposition is done within a solution neutral environment, meaning that one knows first what the design needs to accomplish, and only after fully decomposing the design does it become apparent how the design will achieve the desired functionality. Interactions between the functions of the design are studied and made note of in the design matrix. In order for the design to be free from coupling all interactions on the design matrix must occur below the diagonal on the matrix. If it is not possible to order the functions of the design in such a way that all interactions occur below the diagonal, then the design is thought to exhibit coupling and is not considered a viable design. Keeping interactions below the diagonal on the design matrix requires that the separate functions of the design decomposition be prioritized so that design parameters interact only with functions that are decidedly less important.

2.4.2 Conventional Design

Conventional design is accomplished through a series of specific steps. Norton's Design of Machinery (which was used as a guide in the conventional design portion of this project) explains a design process consisting of ten steps, the first of which is the identification of need.¹⁷ Before conceiving any solution, the designer is to begin with an understanding of the problem and needs that must be fulfilled. Much like axiomatic design, this is looked at objectively and solution neutral. The question is strictly "what" needs to be done, not "how" it will be done.

Following the identification of need is background research, which Norton considers to be one of the most important and most overlooked steps in design.¹⁸ To be effective in designing, one needs to have a complete understanding of the problem and subjects to which it is related, including physical and chemical characteristics. For this project, background research demands knowledge of the properties of pellet ash; its density, its temperature, its compressibility, etc. Background research also includes an investigation of previous solutions to the problem, including both market research and reviews of relevant patents or patent applications. This allows the designer to observe what has and has not worked in the past, and also provides insight to any new technology and techniques being used.

Once the problem is fully understood, a goal statement can be formulated. Again similar to axiomatic design, the goal statement is solution neutral, and explains only the necessary tasks to be accomplished. For example, a goal statement would be to *move* ash, not to vacuum, push, pull, or sweep it. This leads to the development of task specifications. The specifications are a breakdown of the overall goal statement, yet are still not indicative of a solution. Task specifications include statements such as "must operate under 50dB" or "must weigh less than 30 lbs." that describe what the solution must do.¹⁹

Ideation and invention begins after the background and specifications are set. The ideation process is a brainstorming of ideas for fulfilling the task specifications and meeting the goal statement. This step is where conventional and axiomatic design separate. At this point in conventional design, the designer may develop one process that accomplishes every functional requirement, instead of one solution for each requirement. There is more room to ideate with the complete process in mind. The ideation step is meant to be approached with no judgment of the quality of ideas, which will be left for the analysis stage.

There are many methods for ideation ranging from group approaches to analogous thinking techniques. These are discussed in the Methodology section. Ideation is done at first to generate numerous raw concepts without any criticism or analysis of ideas. Once a number of possible ideas are produced, they are then analyzed with goal and task specifications in mind. Ideas are considered based on their feasibility and functionality. Those that are accepted as viable solutions will be considered in the selection step.

Selecting a design is of course a crucial step. It is necessary to reduce the number of designs as much as possible, but it is also important to avoid eliminating good ideas. The selection process of conventional design often produces even more solutions by requiring the designer to classify the individual characteristics of their designs. This can be considered both beneficial and disadvantageous, as it widens the scope of solutions that need to be reduced.²⁰

Design selection can be done in many different ways. There are a number of selection methods that may be used, including decision matrices or weighted selection categories. A designer may simply choose what he or she believes to be the best design or employ a technique to minimize bias in design selection. In a decision matrix (not to be confused with the axiomatic design matrix discussed earlier), each design is scored in categories such as cost, safety, effectiveness, or whatever other parameters are integral to the application of the design. The score on each design across the categories reflects how well it accomplishes the goal, and the design with the highest score is considered the strongest solution.

The solution parameters in the matrix may also be weighted. For example, if safety is more important than cost, the score of each design in the safety category could be multiplied by some factor. This allows a designer to choose the best design for specific needs and desires. At this point the design is no longer neutral. Using any parameter other than functionality to influence the final design implies some kind of judgment from the designer, and the solution selected by a decision matrix is thereafter biased towards one or more new considerations.

Once a solution is selected, it is designed in detail. This includes a more thorough analysis and evaluation of kinematics and dynamics of the design. The detailed design step results in drawings of the design that can be used for prototyping. Following the designing stage is prototyping and testing. Once a prototype is produced, it needs to be tested to make sure that all task specifications are met. Test criteria need to be created so that the design may be

evaluated for the goal statement and each of the requirements previously set. If the prototype meets all of the specifications, it can then be put into production.

To recap the conventional design process, the steps are as follows;

- | | |
|--------------------------------------|-----------------------------------|
| 1. Identification of Need | 6. Analysis |
| 2. Background Research | 7. Selection |
| 3. Goal Statement | 8. Detailed Design |
| 4. Performance Specifications | 9. Prototyping and Testing |
| 5. Ideation and Invention | 10. Production |

(Adapted from *Design of Machinery*)²¹

These are the steps followed in our conventional design for the project, where we complete our work on step 9, prototyping and testing. This design process is not always linear. It will almost certainly involve much iteration of any or all of the steps.²² The goal statement may be changed, new ideas may be generated, or the final design may not work at all. In the conventional design process, each step may be revisited multiple times.

3.0 Design Methodology

3.1 Design

Axiomatic and conventional techniques were used to generate design solutions for an automatic ash removal system. It is found that the two approaches have many similarities but can still yield quite different solutions. Axiomatic design uses an iterative process, where the necessary functional requirements and their mated design parameters are rearranged until a complete design solution evolves. The process is fixed to objective based solutions that accomplish basic functions, with the final design being a combination of solutions to each functional requirement. This simplifies the problem and often leads to the simplest solution, minimizing interactions between sub functions of the system. Conventional design can be used to create individual solutions for each requirement as well, or one function that provides for all of the requirements. This solution may not be the best for each individual requirement, but having only one function provides a desired simplicity to the design as well. Both methods of design contribute to the process, and work well when combined and contrasted to give multiple perspectives of the design problem and solutions.

3.1.1 Design Requirements

Regardless of the methods used, requirements must be met for the final design to be successful. Our initial goal was to collect and store ash, as well as provide for easy removal of ash by the user. As we moved further into our design process, the goals were refined and reduced to basic functional requirements. This process is an important part of both axiomatic and conventional design, as it allows the designer to focus on the most basic requirements to be met.

3.1.2 Axiomatic Design

Axiomatic design methods were used to focus on the necessary functions of the design. These functions were found first in general terms. Once a complete solution neutral conceptual design was created, more thought was given to the actual sub systems, which will provide for the necessary functions of the system as a whole. Some of the functions needed in the design, such as burner bowl ash removal, and the flame tube ash removal are already provided for by existing systems. Other functions were easily solved by immediately apparent systems, such as using some sort of bin for ash storage. Other functions such as the transport of ash entailed many more options and were not so easily mated to a system.

The primary function of the project is to design a system which automatically removes ash from a wood pellet boiler. In the axiomatic design decomposition this primary function becomes Functional Requirement 0 (FR0) and is provided for by Design Parameter 0 (DP0) which is the system being designed. The functions which the automatic ash removal system (DP0) must complete are the three functions which are children of DP0. These three functions represent processes which are separate from one another, and which together complete all the functions required of the system. They are in order; remove ash from functional services, provide for clean and convenient emptying, and gather all ash, as shown in Table 3.1.

Table 3.1: Functional Requirements of the Ash Removal System

#	[FR] Functional Requirements	[DP] Design Parameters
0	FR Automatically Clean the Boiler and remove ash	DP Automatic Ash Removal System
1	FR Remove Ash From Functional Surfaces	DP Surface Ash Removal System
2	FR Provide For Clean and Convenient Emptying	DP Portable Sealed Bin
3	FR Gather All Ash	DP Ash Gathering System

The three general functions of the ash removal system exhibit sequential coupling meaning that the ash cannot be gathered until after it has been removed from the surfaces. Likewise, the ash cannot be emptied before it has been gathered. With the three general functions of the system defined, it is necessary to elaborate on what secondary functions are required for the primary functional requirements. In other words the decomposition must be expanded. A decomposition of the first FR is shown in Table 3.2 below.

Table 3.2: Functional Requirement 1 Decomposition

#	[FR] Functional Requirements	[DP] Design Parameters
1	FR Remove Ash From Functional Surfaces	DP Surface Ash Removal System
1.1	FR Remove Ash from Burner Bowl	DP Ash Scrape System
1.2	FR Remove Ash from Flame Tubes	DP Flame Tube Ash Removal System

FR1, remove ash from functional surfaces, is provided for in the decomposition by DP1, surface ash removal system. The child functions which make up this system are FR1.1, remove ash from burner bowl, and FR1.2 remove ash from flame tubes. These two functions together make up the surface ash removal system DP1. The Janfire burner currently removes the ash from the burner bowl after a certain amount of pellets have been burned with an ash scrape cycle. The ash scrape cycle requires that combustion has stopped and that the burner has cooled to a certain temperature, then the bottom of the burner bowl is slid back into the burner forcing the ashes inside the burner bowl to fall to the bottom of the boiler. This system exists and provides for

FR1.1, FR1.2, remove ash from flame tubes, requires that ash which would otherwise cause fouling on the heat exchange surface be removed. Spiral turbulators are currently used to increase convective heat transfer within the flame tubes for solid fuels such as wood. Ash on the inside walls of the flame tubes is removed by movement of the turbulators inside.

The second primary requirement of this system is FR2, provide for clean and convenient emptying. Table 3.3 shows that this function cannot be further expanded upon as it is fully provided for by a portable bin which is fully sealed, thus allowing the ash to be removed and emptied without creating a mess.

Table 3.3: Functional Requirement 2

#	[FR] Functional Requirements	[DP] Design Parameters
2	FR Provide For Clean and Convenient Emptying	DP Portable Sealed Bin

The third primary function FR3, gather all ash, requires two child functions to be completed. The two functional requirements needed to gather all ash are; collect the ash FR3.1 and store the ash FR3.2. Collecting the ash requires that the ash be consolidated FR3.1.1 and moved FR3.1.2. The ash can be consolidated in the bottom of the boiler by sloped sides which will force the ash to slide to a central location. The decomposition of FR3 is shown in Table 3.4.

Table 3.4: Functional Requirements 3 Decomposition

#	[FR] Functional Requirements	[DP] Design Parameters
3	FR Gather All Ash	DP Ash Gathering System
3.1	FR Collect Ash	DP Ash Collection System
3.1.1	FR Consolidate Ash	DP Sloped Sides in Boiler Bottom
3.1.2	FR Move Ash	DP Ash Transportation System
3.1.2.1	FR Prevent Ash From Being Released	DP Fully Closed System
3.1.2.2	FR Drive Ash	DP Ash Propulsion System
3.1.2.3	FR Direct Ash to Storage	DP Ash Channel
3.1.2.4	FR Unload Ash in Storage	DP Ash Discharge
3.2	FR Store Ash	DP Ash Bin

The ash must also be moved (FR3.1.2) for it to be collected this is done with an ash transportation system (DP3.1.2). In order to move the ash, four children functions must be provided for. It is also important that ash not be released into the surroundings during transportation (FR3.1.2.1). This requirement will likely be achieved by maintaining a system which remains closed to the surroundings (DP3.1.2.1). In order to physically move the ash the ash must be driven or have a force applied to it, (FR3.1.2.2). The motion of the ash must also be

directed (FR3.1.2.3). This can be achieved by some sort ash channel to direct the translation of the ash (DP3.1.2.3). Finally the ash must be unloaded into storage (3.1.2.4).

The other child of FR3 is FR3.2 store the ash, which can be provided for by a bin, assuming the same bin as DP2 is used for DP3.2 it is required that the bin be sealed and removable for emptying. DP2 thus interacts with FR3.2 requiring; the storing of ash, FR3.2, to be done in a way which allows for clean and convenient emptying, FR2. This requires the storage bin to be sealed and removable.

Interaction between different systems and functions is common in designs. It becomes a problem when the system functions cannot be prioritized in such a way that less important functions experience interaction upon their functions only with higher level design parameters. In order to explore the inherent interactions between functions in the system a design matrix is created, and interactions are labeled with a blue “X”. This matrix is shown below in Figure 3.1. The Functional Requirements and Design Parameters that have no interactions are marked with a green “O”, while grey cells hold the place for design parameters which are children of a functional requirement, allowing the matrix to be square when shown expanded as in Figure 3.1

	DP0: Automatic Ash Removal System	DP1: Surface Ash Removal System	DP1.1: Ash Scrape System	DP1.2: Flame Tube Ash Removal System	DP2: Portable Sealed Bin	DP3: Ash Gathering System	DP3.1: Ash Collection System	DP3.1.1: Sloped Sides in Boiler Bottom	DP3.1.2: Ash Transportation System	DP3.1.2.1: Fully Closed System	DP3.1.2.2: Ash Propulsion System	DP3.1.2.3: Ash Channel	DP3.1.2.4: Ash Discharge	DP3.2: Ash Bin
FR0: Automatically Clean the Boiler and remove ash	X													
FR1: Remove Ash From Functional Surfaces	X													
FR1.1: Remove Ash from Burner Bowl		X												
FR1.2: Remove Ash from Flame Tubes		X	X											
FR2: Provide For Clean and Convenient Emptying					X									
FR3: Gather All Ash	X	X		X	X									
FR3.1: Collect Ash		X				X								O
FR3.1.1: Consolidate Ash							X	X						O
FR3.1.2: Move Ash		X					X	X						O
FR3.1.2.1: Prevent Ash From Being Released									X					O
FR3.1.2.2: Drive Ash										X				O
FR3.1.2.3: Direct Ash to Storage											X			O
FR3.1.2.4: Unload Ash in Storage												X		O
FR3.2: Store Ash				X										X

Figure 3.1: Complete Axiomatic Design Matrix

The present ash scrape system on the Janfire NH burner operates only after a certain amount of pellets has been burned and the burner is shut off. Because of this, the ash scrape cycle is an ideal time to run any electronic or motorized sub-systems of this design. An electric signal taken from the ash scrape motor can be used to run the motor which removes ash from the flame tubes DP1.2 and run the ash transport system DP3.1.2. While this decision to use the already present ash scrape logic to control many functions makes the design process simpler, it introduces a number of interactions to the system.

3.1.3 Conventional Design

The conventional design process was done following the steps outlined in the Background section. Many of the first steps are similar to those in axiomatic design, such as the identification of need and the generation of functional requirements, both of which are considered without indicating any form of final solution.

Background Research

To obtain an understanding of the problem, research was done on pellet heating and ash removal systems already on the market. There are a number of manufacturers that offer ash removal solutions for wood pellet heaters, including two European companies Ökofen and Froling. Many of the existing solutions implement an auger for removing ash from below the burner to a more accessible location. Some include a removable bin into which the ash is pushed. When the bin is full, it can simply be taken from the system, emptied, and returned.

The Ökofen Boiler employs an auger to transport and compress ash. In the Ökofen solution, an auger lies below the burner plate from which ash falls, as shown in Figure 3.2 below. As the ash accumulates in the bottom of the boiler, a rotating bar pushes ash around the circular chamber so that it does not pile up. As the auger rotates it transports ash away from the bottom of the boiler and into a removable ash bin. The auger brings the ash to the base of the bin, where a ball joint allows the ash to flow up into the bin. The auger senses when the bin is full based on the torque necessary to push ash into the bin. Once this bin is full the ball joint is closed manually, and the bin can be removed and emptied. This design is effective because of the ash compression, which allows more ash to be stored in a small space, decreasing the frequency with which the system must be emptied.

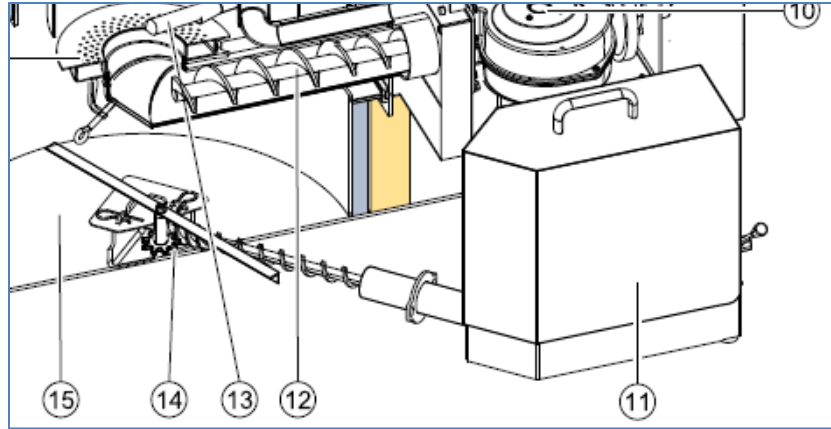

Figure 3.2: Ökofen Automatic Ash Removal Solution²³

The Kozlusan boiler uses a similar system, except that it uses two augers to drop ash into a bin, rather than fill it up from the bottom. This solution is shown below in Figure 3.3.



Figure 3.3: Kozlusan Ash Removal System²⁴

Many systems allow ash to build up to a certain level in the bottom of the boiler and only remove the excess ash, allowing hot new ash to cool before transporting it to the bin. The ash which is not removed can stay in the bottom of the boiler indefinitely or until it is fed into the auger. Ash accumulation in the bottom of the boiler does not adversely affect the operation of the boiler until it piles up high enough to reach the bottom of the burner, reducing the available volume of the combustion chamber and leading to incomplete combustion, reduced efficiencies, and causing an increase in Carbon Monoxide and Nitrogen Oxides in the exhaust gases.²⁵

Although most fully automated ash removal systems use an auger to transport ash to a storage bin, and often compress it, some systems offer a lesser degree of automation by simply having a removable bin or tray in the bottom of the boiler, which can be emptied as needed by

the user.²⁶ The Austrian Ökofen boiler imported by Maine Energy Systems (when not sold with an ash removal system) uses a suspended screen under the burner which is raised and lowered by an ash cleaning mechanism to increase the amount of ash which can build up between cleanings by forcing it to accumulate more densely.²⁷

Additional research was done on the characteristics of the ash to be used. Current automated wood pellet boilers require the pellets to be of premium quality, a standard which is set by the Pellet Fuels Institute. In order to be graded as premium, the ash content of the pellet must be between 0.5 and 1% of the pellet mass.²⁸ This means that burning one ton (2000 lbs) of premium quality pellets will result in the creation of 10 lbs of ash. For a larger home burning an average of 10 tons of pellets a year, 100 lbs of ash will be created. In this case, ash will have to be removed four times per year with a 25 lb bin. The average household heating primarily with wood pellets burns 8 tons of wood pellets a year. With 1% ash content the amount of ash produced in a year for the average household is 160 lbs. The average household using a 25 lb ash bin would have to empty the ash 7 times each year, mostly during the heating months.

Ideation and Analysis

Many possible solutions were considered in the ideation process. Solutions were based on the functional requirements and task specifications; ash needed to be moved, consolidated, and stored. A full list of task specifications used for the design is given below.

Performance Specifications

- Must remove ash from surfaces of the boiler.
- Must collect, consolidate and store ash into one location.
- Must provide for an easy and clean disposal of ash.
- Removal device (bin or other solution) must weigh no more than 30 lbs. when full of ash, if it is to be lifted by the user.
- Bin must be easily accessible by the user (placement).
- Solution must stand up to the conditions to which it will be subjected (corrosive ash, high temperatures).
- Solution must be as compact as possible, i.e. not add excessively to the footprint of the boiler.

- Any components with which a user interacts must be safe (temperature, sharp edges, heavy objects).
- The system must run from electricity supplied by the existing boiler unit.
- Solution must remove ash as fast as or faster than ash is produced by the burner, so that ash does not build up and restrict the operation of the burner.
- Must not affect the performance of the burner in any way.
- Must not release any ash into the environment, unless through the design flame tubes.

More research was done to aid in the ideation process. Ideation seems to imply a need for natural creativity, but there are many documented techniques to aid in the generation of possible solutions. Pahl and Beitz split the ideation process into conventional, intuitive, and discursive methods.²⁹ The conventional category includes the use of literature, naturally occurring systems, existing systems, and analogy to generate potential solutions. For example, we may try to consider natural systems for transporting material, such as the peristaltic process (muscle contraction) that moves food and waste through the human body. This example seems complex for the design at hand, but other natural process may provide a solution and should be considered.

Intuitive techniques include brainstorming and other group exercises in which peers may review and expand upon the ideas of others. There are multiple specific systems for intuitive ideation, but a combination of any can be productive. Discursive ideation includes the study of physical processes that apply to the problem statement, as well as a review of existing technology such as a design catalogue. Any combination of techniques from one or all categories can be used.³⁰

Ideation for our design was mostly conventional and intuitive. Literature review, brainstorming, and examination of existing systems were heavily used to generate initial ideas. Further in the designing and redesigning processes, discursive methods were used to refine the design. The requirements of consolidation and transportation led to many different potential solutions. Ideas included augers, vacuums, rams, blowers, conveyors, etc. Once these ideas were generated, they were analyzed for their feasibility of implementation. Those that appeared as possible designs were then evaluated in a decision matrix to decide which would be pursued.

3.1.4 Selection

The selection of a final design was based on parameters such as cost, safety, robustness, innovation, ease of production, life cycle, etc. It was clear that some of these parameters were more important to Maine Energy Systems as a business, while others were more important to the project as an MQP. For example, innovation doesn't affect the choice of the best design for MESys, while cost and portability do not affect the major qualifying project for WPI. Because there were two different needs, it was appropriate to select designs in two different ways.

Each potential design was given a score from 1 to 5 in each category (as shown in Table 3.1) with 5 being the best and 1 being the worst score. Because different parameters held more or less importance depending on the two different needs, weights were applied to each category depending on that category's importance. The resulting matrix is shown below in Table 3.5, with design ideas marking each row and scoring categories marking the columns.

Table 3.5: Design Decision Matrix

	Cost	Safety	Simplicity	Robust	Innovation	Production	Ease of Use	Life Cycle	Empty Cycle	Portability
Auger	3	4	4	4	2.5	3	5	5	5	5
Vacuum	1.5	2	2.5	3	5	3	5	4	5	5
Manual Box	5	4	1	3	5	1	4	4	3	2
Scrape/Ram	4	4	3	4	3	3	4	4	5	3
Tray	5	4	5	5	0	4	5	5	3.5	3
Blower	4	2	2	4	5	2	4	5	5	4
Conveyor/Chain	4	4	4	5	2	3	4	5	3	2
Hydraulic	2	5	2	4	4	1	3	4	3	4

The weighting system was created based on the two different needs. The most important parameters for Maine Energy Systems as a business were given the highest weights. Cost, safety, ease of use, and the ease of implementation (portability) hold the most weight for MESys. Clearly the company would like for the ash removal systems to cost as little as possible to purchase and install in its boilers. MESys also requires that the systems be safe for their customers, last for a long time, and be efficient in terms of minimizing the frequency with which

an ash bin needs to be emptied (“Empty Cycle” in Table 3.5). Innovation is of no importance for Maine Energy Systems, so it was given a weight of zero. The method by which ash is removed does not matter as long as the requirements are fulfilled.

The WPI weight system is based on parameters that are most important to the design as a Major Qualifying Project. For this system cost, portability, and simplicity have little or no influence on the final design. The requirements of the design project must still be fulfilled, that is the basic functions of removing ash from the system, etc, but the categories given the most weight are innovation, ease of production, ease of use, and empty cycle. Ease of production is necessary because of constraints on time and resources for us to construct and test the design. Ease of use and empty cycle are original goals of the project to create a system that was simple for the user, and minimized the frequency of emptying. Lastly, innovation is important for our MQP because we want to design a new system, and not simply recreate an existing solution.

3.1.5 Selection Results

The resulting total scores for various weights are given by Table 3.6, with the highest in each category shown in bold.

Table 3.6: Results of Decision Matrix

	Unweighted Total	Weight MESys	Weight WPI
Auger	40.5	62	44
Vacuum	36	50.5	45.25
Manual Box	32	47	35.5
Scrape/Ram	37	55.5	41.5
Tray	39.5	63.25	39.5
Blower	37	53	43
Conveyor/Chain	36	54.5	38
Hydraulic	32	47.5	33.5

Two final designs were selected by the weighting system, with one more appropriate for MESys’ needs, and the other chosen for the MQP. Though the tray concept had the highest score in the MESys weighted column, it will not be further investigated in detail due to its simplicity. It will be recommended to MESys as one of the best solutions, but will not be further analyzed in this paper. The auger system was selected by the MESys weights, and the vacuum was selected for WPI. We investigate again to ensure that the Axiomatic Design Requirements can be fulfilled by these systems.

Auger System

With an auger transportation system the ash is driven with an auger motor (DP3.1.2.2), directed towards the storage with the screw auger's flight pitch (3.1.2.3), the ash is pushed upward into the bin by the reversed threads at the end of the auger (DP3.1.2.4). The ash is prevented from being released by keeping the transport system sealed from the surroundings (DP3.1.2.1). The design matrix for an auger is shown in Table 3.7.

Table 3.7: Axiomatic Design Matrix for Auger System

#	[FR] Functional Requirements	[DP] Design Parameters
3.1.2	FR Move Ash	DP Ash Transportation System
3.1.2.1	FR Prevent Ash From Being Released	DP System Seals
3.1.2.2	FR Drive Ash	DP Auger Motor
3.1.2.3	FR Direct Ash to Storage	DP Screw Auger Flight Pitch
3.1.2.4	FR Unload Ash in Storage	DP Reversed Auger Thread

Vacuum System

Although the vacuum method is not currently used in the industry, it is a possible solution as it provides for all the necessary functions of the ash transport system. The three general requirements for the ash transportation system are Drive, Direct and Discharge the ash. These requirements are provided for by a vacuum, suction lines and some kind of separator or filter, respectively, as shown in Table 3.8.

Table 3.8: Axiomatic Design Matrix for Vacuum System

#	[FR] Functional Requirements	[DP] Design Parameters
3.1.2	FR Move Ash to Storage	DP Ash Transportation System
3.1.2.1	FR Prevent Ash From Being Released	DP Return Air Vent
3.1.2.2	FR Drive Ash	DP Vacuum
3.1.2.3	FR Direct Ash to Storage	DP Suction Hose
3.1.2.4	FR Unload Ash in Storage	DP Separator

The requirement that the system prevent ash from being released into the home is provided for in the vacuum system by the use of return air venting. By blowing the carrying air back into the boiler once the ash has been separated, we can prevent any ash dust which wasn't removed from being released. Once the air is vented back to the boiler it is expected that it will be vented out the chimney due to the existing draft, removing the dust with it.

The use of an auger is seen in existing ash removal systems and is a solid, confirmed solution to the problem. The vacuum system is not seen in the industry and is more experimental and innovative, though it could still prove to be the best solution. It was decided that both

designs would be developed, fabricated, and tested. Figures 3.4a and 3.4b below show the basic conceptual design for these two solutions.

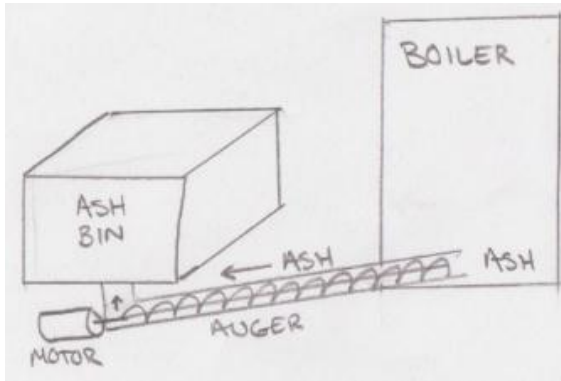

Figure 3.4b: Auger System

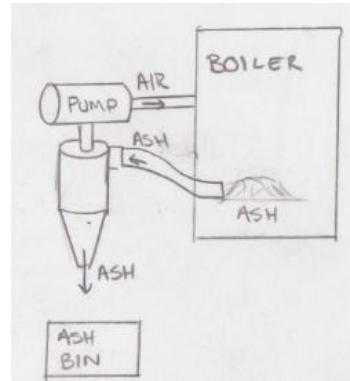

Figure 3.4a: Vacuum System

3.2 Further Design

The design of the ash removal systems and their components depend on ash properties such as density and compressibility. The auger must be both large enough and powerful enough to move the required amount of ash. The same can be said for the vacuum system, which must be designed for the correct ash particle size and able to stand up to the heat and corrosiveness of ash. Both systems will also need a removable storage bin capable of holding the required amount of ash.

Systems will be designed to operate on the fixed ash scrape cycle which is already present in the Janfire burner. The ash scrape cycle occurs after a certain amount of pellets has been burned, which is set by the operator and normally ranges between 30 and 45 lbs depending on the actual ash content of the pellets being burned. Knowing roughly the amount of pellets burned as well as the ash content of the pellets allows us to estimate the amount of ash created between ash scrape cycles. In order to keep up with ash creation, the amount of ash removed by the system during the ash scrape cycle must be able to exceed the amount of ash created between cycles.

It was decided that the maximum weight of ash in the ash bin would be approximately 25 pounds. This bin must be removed by the user, so it can't be too heavy to lift. By weighing a known volume of uncompressed ash we determined experimentally that the density of uncompressed pellet ash is about 23 lbs per cubic foot. So the volume of the ash container to be designed will be about one cubic foot or less if the ash is significantly compressed. The bin also

needs to be designed so that it can be easily lifted and dumped, meaning that it can't be so long or so tall that it be hard for the user to handle.

3.2.1 Auger System

The auger used to move the ash has several requirements. The motor used to drive it must be robust and powerful enough to pack ash into the bin. The auger itself must be capable of moving enough ash to keep the burner area from filling. Because the amount of ash removed from the burner during each scrape cycle is small, a slow moving gear reduced motor is an ideal solution. The torque of the motor will need to be considerable if it is to compress the ash inside the bin. The motor also must be protected to prevent it from burning up when the bin is completely full and the ash is fully compressed.

Power Requirements

The horsepower requirements for the ash auger were found using the equations below. The power required for a horizontal auger is a combination of the power required to turn the empty screw conveyor and the power needed to overcome the material friction forces. The calculations below were used to find both power requirements (Equation 3.1 and 3.2) as well as the total power requirements for the auger motor (Equation 3.3).³¹

Equation 3.1
$$Hp_f = \frac{L N F_d F_b}{1 \times 10^6}$$

Equation 3.2
$$Hp_m = \frac{C L W F_f F_m F_p}{1 \times 10^6}$$

Equation 3.3
$$Hp_{total} = \frac{(HP_f + Hp_m) F_o}{e} = 0.0016 \text{ hp}$$

C = Capacity.....	1	in ft ³ /hr
e = Drive Efficiency.....	0.95	(speed reduction gear motor) ³²
F_b = Hanger Bearing Factor.....	1.0	(ball bearings) ³³
F_f = Flight Factor.....	1	(standard flight type) ³⁴
F_m = Material Factor.....	2.0	(dry ashes) ³⁵
F_o = Overload Factor.....	4.4	(interpolated) ³⁶
F_p = Paddle Factor.....	1.0	(no paddles) ³⁷
L = Total Length Of Conveyor.....	2.5	in feet
N = Operating Speed.....	3	in rpm
W = Density Of Material.....	40	(dry ashes) ³⁸

The total required horsepower found using the above method for this auger configuration is 0.0016 horsepower. The motor being used to power the auger is a purchased component from

McMaster-Carr. This motor provides 50in-lbs of torque at 3rpm, with the power produced calculated to be 0.0024 horsepower, as shown in equation 3.4, well above the calculated power requirement of the auger.

Equation 3.4
$$Hp_{motor} = \frac{50in-lbs \times \frac{1ft}{12in} \times 2 \times \pi \times 3rpm}{33000} = 0.0024$$

The use of a standard sized auger will expedite the fabrication of a prototype, though modifications will have to be made to allow the auger to push material up into the bin once it has reached the end of the screw. The standard size is also larger than what is needed to move the necessary volume of ash, but will be used in testing to evaluate viability of the principle function.

Initial Auger Design

The proposed design of the auger system is developed with these considerations. A model of the system is shown in Figure 3.5. Inside the boiler, an auger is turned by an AC motor to bring ash out and into the green removal bin. As seen below, the removal bin sits on a support that also encases the motor. The bin contains a valve that can be closed to prevent ash from falling out upon removal of the bin.

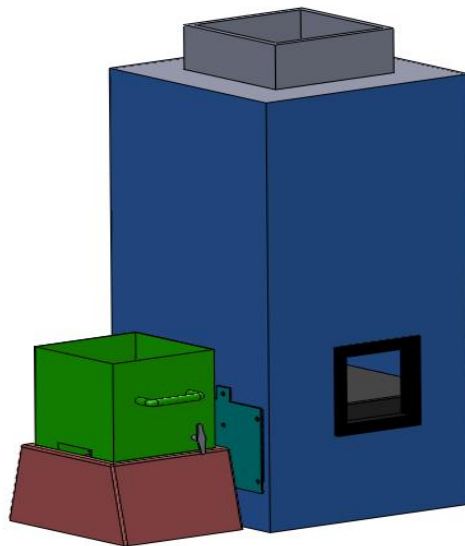

Figure 3.5: Initial Auger System Design

The cross section of this design is shown below in Figure 3.6. The dark blue component gathers ash falling from the burner bowl. Its walls are sloped at 33 degrees, slightly more than

the angle of repose of the pellet ash (evaluated experimentally by the team). After sliding down these walls, the ash falls into the open trough containing the auger. As the auger rotates it pushes ash out of the boiler. At the end of the auger, the thread is reversed to make the ash flow upward and into the bin. A circular opening in the bottom of the bin allows ash to enter through a valve.

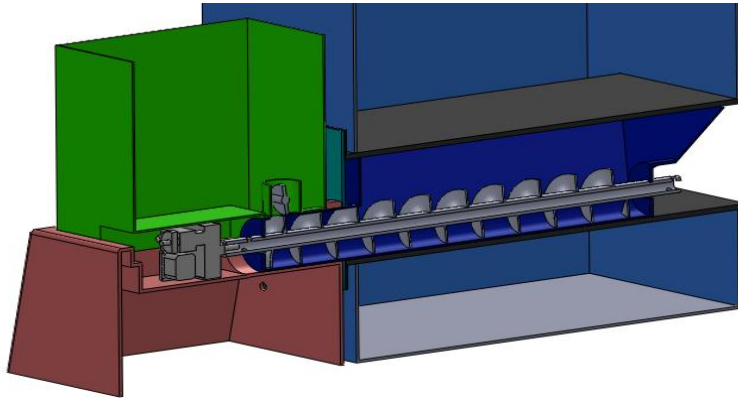

Figure 3.6: Cross Section of Auger System

Once the bin is full, the valve can be closed and the bin can be removed and emptied. The energy required to turn the auger motor will be monitored to sense how much is needed to make the auger rotate. In this way, we will be able to evaluate when the bin is full based on how hard the motor is working to turn the auger. From this, a signal can be obtained and used to alert the owner or user that the bin needs to be emptied.

The motor to be used to turn the auger produces 3 rpm and 50 in-lbs of torque, enough to force ash through the pipe and up into the bin (as discussed earlier in this section). This motor is shown below in Figure 3.7.

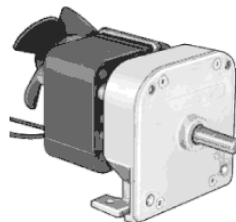

Figure 3.7: AC Gear Motor³⁹

3.2.2 Vacuum System

We investigated existing technology for removing particulates from air to help guide the design of a vacuum system. Research led to four basic emission control technologies; electrostatic precipitator (ESP), baghouse, scrubber, and cyclone.⁴⁰ An ESP creates a charge in

the particles that forces them to attract to collection plates, thus removing them from an air stream. A baghouse uses fabric filters to trap airborne particles. These filters must be removed and replaced over time, and are susceptible to heat damage, which is a concern for the pellet boiler application. Scrubbers inject a cleaning liquid spray to the airflow that attaches to the particles, making them heavy and easier to remove. These three techniques are generally used in applications on a larger scale than our own, and are overly complicated for the necessary function, leaving the cyclone to be considered.

The cyclone solves the problem of potential heat damage in the separating system, as it uses no filters and can be made entirely of corrosion resistant metal. The ash removal system is designed to operate only while the burner is off for an ash scrape cycle so that there is no danger of having fast moving air near a flame. There will also be no need for replacement of parts or maintenance on the cyclone, making it the best solution for the application of a vacuum system. A schematic of a cyclonic separator (cyclone) is shown below in Figure 3.8.

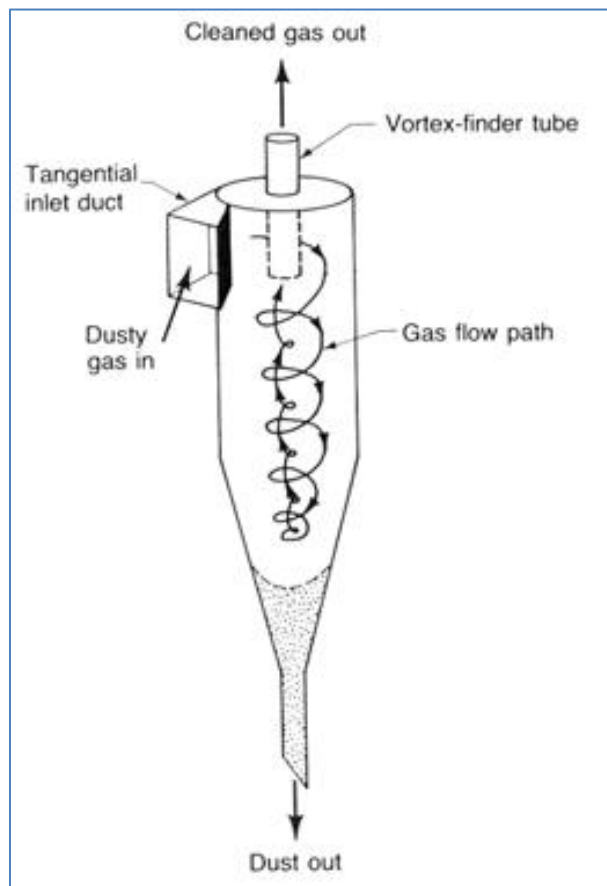

Figure 3.8: Schematic of Basic Cyclone⁴¹

The separator is a cone that uses a vacuum force to spin particles around in a cyclone. At the bottom of this cone, the air sucked in makes a sharp turn up to exit at the top of the separator. Particulates are forced to the outside due to their larger mass and have too much momentum to make this turn, and so are dropped out of the bottom. The dimensions of this cone (Figure 3.9) as well as the vacuum speed and force are dictated by the size of the particles it will be vacuuming. These calculations need to be precise or include a safety factor, as the motor powering the vacuum could be ruined if hot ash made it through the separator.

The necessary inlet velocity, V_i , to capture 100% of particles larger than or equal to a certain particle diameter is modeled by Equation 3.5.⁴²

Equation 3.5
$$V_i = \frac{9\mu W}{\pi N(\rho_p - \rho_a)d_p^2}$$

- V_i = Inlet Velocity
- μ = Air Viscosity
- W = Width of Inlet
- N = Number of turns
- ρ_p = Particle Density
- ρ_a = Air Density
- d_p = Particle Diameter

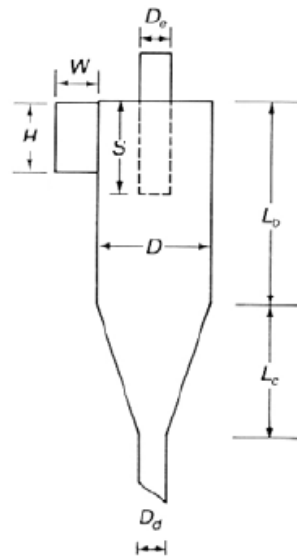

Figure 3.9: Critical Cyclone Dimensions

Also critical in the design of a cyclonic separator are the dimensions shown in Figure 3.9 above.⁴³ These are also modeled by equations, all depending on the size of the gas exit D_e . Equations used to design the dimensions and parameters of the cyclone system are adapted from reference 42.

We chose a particle inlet of 1.75” by 2”, which is large enough to accommodate unbroken pellets that might occasionally be vacuumed into the cyclone. The rest of the dimensions are based on the size of the ash that we want to collect, which is about 20 microns in diameter.⁴⁴ The velocity needed to effectively collect 100% of particles this size is calculated as 1.06m/s. This is the speed that the air needs to have at the inlet of the cyclone.

In researching the use of cyclonic separators we found that it is difficult to design for the capture of 100 percent of particles as small as 20 microns, and that some lighter ash particles will likely make it through the wrong exit of the separator. For this reason the cyclone cannot be powered by any motor that could potentially be damaged by contact with ash. Instead we will use what is called a vacuum pump to create suction. As shown in Figure 3.10 below, the vacuum pump (or vacuum generator) works by the application of compressed air to the top of the pump. Air is forced out the exhaust, creating a vacuum in the other end of the pump. This kind of system is designed for mass transfer and will be easily capable of handling any small ash particles that are not collected by the separator. However, this design requires the addition of an air compressor to operate the air pump⁴⁵, making it both more complicated and costly.

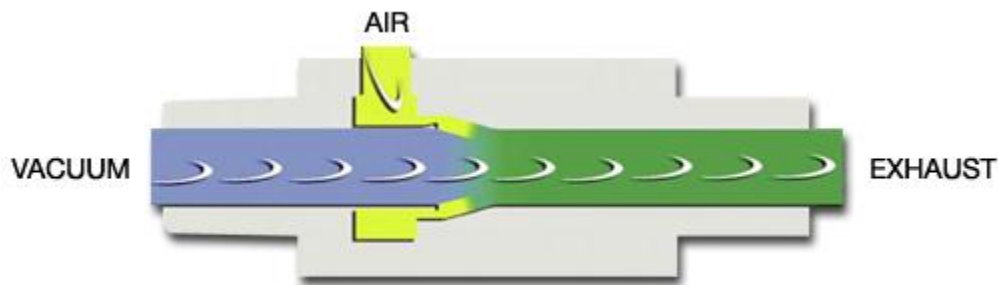

Figure 3.10: Vacuum Pump⁴⁶

Based on the inlet size and calculated inlet velocity of our designed cyclone, we can evaluate the volumetric air flow rate that must be produced by the vacuum pump. The flow rate is simply the velocity multiplied by the inlet area. This comes to only 2 cubic feet per minute (CFM), which should be produced easily with relatively low air pressure to the vacuum generator. The vacuum generator chosen for this application is the Air-Vac TDRH1500L, which is capable of producing a flow of 140 CFM at 80 psig.⁴⁷ Figures showing the performances of the vacuum pump are below in Figure 3.11. This vacuum pump is capable of producing a much higher volumetric flow rate than is theoretically necessary, but was chosen for prototyping and experiments for its wide range of operation.

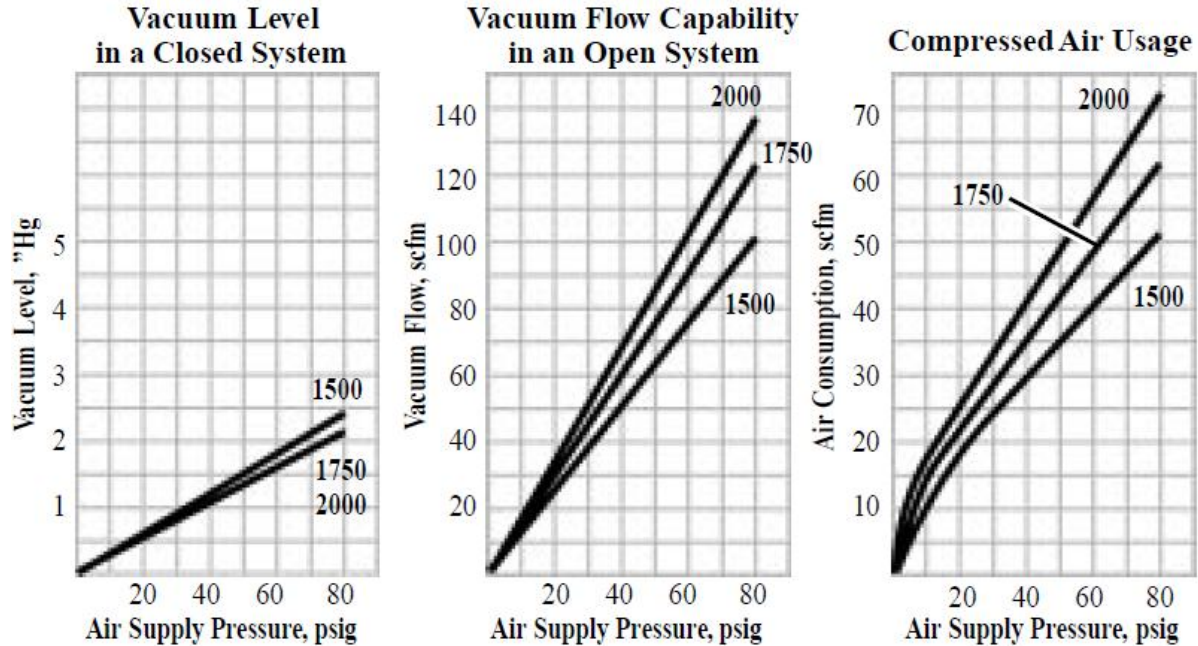

Figure 3.11: TDRH1500L Specifications⁴⁸

Once the ash is removed by the cyclone and pump, air will be exhausted through the boiler and out the chimney. Returning the vacuum air to the boiler and chimney ensures that any small ash particles which are not removed by the cyclone will not be released into the air. It is for this reason that particularly small ash particles do not need to be removed by the vacuum system. Anything which is small enough to be colloidal in air will be removed from the boiler through the chimney as it normally would in the absence of an ash removal system.

Thermal Analysis

The thermal deformation of the cyclone was studied in order to determine if changes in temperature resulting from air flow of hot gases from the boiler's combustion chamber would significantly change the dimensions. This could impede the development the cyclone or vortex, causing poor performance or failure. Significant deformation would be expected to occur in the vertical direction, as the largest dimensions are on the vertical axis.

The heat convection between the inside of the cyclone cylinder and the hot flowing air is assumed to behave as a flat plane with parallel fluid flow. It was not modeled as an internal pipe flow, as the length to diameter ratio is such that the flow will not be fully developed, either thermally or hydraulically. The flow within the cylinder will become fully thermally developed at 76cm and hydraulically developed after that. The prototype cylinder is approximately 15 cm

long. The characteristic length of the plane is the distance the air travels as it flows around the inside of the cylinder.

The Reynolds number for the air flowing around the inside of the cylinder was calculated using the characteristic length, the velocity of the air entering the cyclone, and the viscosity of the air at the elevated temperature. The Reynolds number was found to be high denoting a turbulent fluid flow.

The average Nusselt number was calculated from the equation for mixed flow over a flat plane, modeled by Equations 3.6⁴⁹ and 3.7⁵⁰ below. The average convection coefficient for heat transfer between the hot air and the cylinder wall is found from the calculated average Nusselt number.

$$\text{Equation 3.6} \quad \overline{Nu}_L = \left(0.037 Re_L^{\frac{4}{5}} - A \right) Pr^{\frac{1}{3}} \quad \text{for} \quad \left[\begin{array}{l} 0.6 \leq Pr \leq 60 \\ Re_{x,c} \leq Re_L \leq 10^8 \end{array} \right]$$

where

$$\text{Equation 3.7} \quad A = 0.37 Re_{x,c}^{\frac{4}{5}} - 0.664 Re_{x,c}^{\frac{1}{2}} \quad \text{and} \quad Re_{x,c} = 5 \times 10^5$$

$$\overline{Nu}_L = \frac{h_L L}{k}$$

The Biot number for the cylinder wall was found from the conductivity of the aluminum the thickness of the cylinder and the convection coefficient calculated above. The Biot number was found to be 0.00326, meaning that the lumped capacitance method is appropriate.

$$Bi = \frac{h L}{k}$$

Because the Biot number is much less than one, the temperature of the aluminum is assumed to be reasonably represented by a mean temperature throughout the cylinder. Conservation of energy dictates that heat loss from the air flow be gained by the cylinder wall. Setting up the balance of energy equation and integrating with respect to time results in an equation for the change in temperature of the solid with respect to time. Equation 3.8 defines the ratio of the difference between the current cylinder temperature and the air over the initial difference in temperature between the air and the cylinder.⁵¹

$$\text{Equation 3.8} \quad \frac{T - T_\infty}{T_i - T_\infty} = e \left[- \left(\frac{h A_S}{\rho V c} \right) t \right]$$

The expected temperature change of the cylinder wall during a short vacuum removal time is found as five degrees Celsius, small enough so that the resulting thermal deformation will not cause significant changes in dimensions resulting in reduced performance or failure.

Initial Vacuum Design

After analysis of the cyclone and other considerations, an initial model of the vacuum system was created. The design uses a separator, vacuum pump, and an air compressor to remove ash from the boiler. Figure 3.12 shows the assembly of the system. The vacuum design contains more components than the auger, making it more complicated and potentially more expensive.

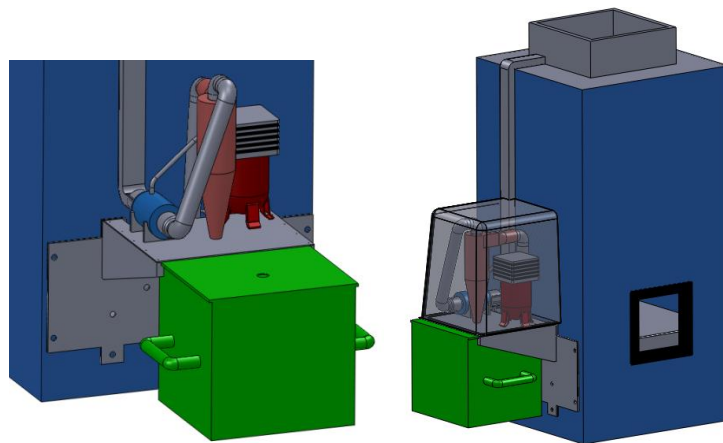

Figure 3.12: Initial Cyclone System Design

Main components are the vacuum pump, cyclonic separator, air compressor, sloped boiler walls, and the ash removal bin. The first step in removal is the collection of falling ash, which is accomplished by the slope of the walls inside the boiler. As ash is scraped from the burner bowl it falls onto the sloped side walls, which are sloped at 33 degrees so that ash will slide down towards the opening in the bottom through which ash will be vacuumed. Figure 3.13 shows the sloped walls inside the boiler (the boiler is transparent to show components).

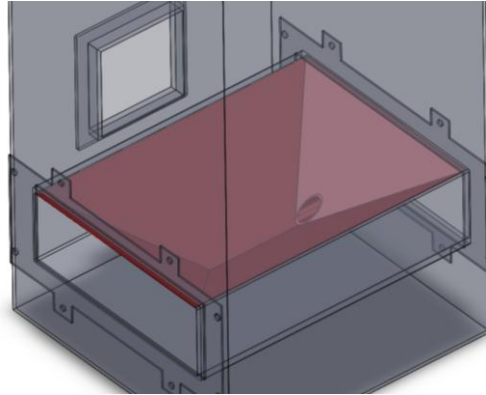

Figure 3.13: Sloped Walls

Once the ash is gathered, the vacuum created by the compressed air and generator drag it through the opening in the sloped walls, then through piping to the cyclonic separator. The ash and air mixture enters through the inlet of the cyclone, and is spun around the separator to remove particles from the air stream as previously discussed. This piping and the separator are shown in Figure 3.14, with a section view of the cyclone at the right.

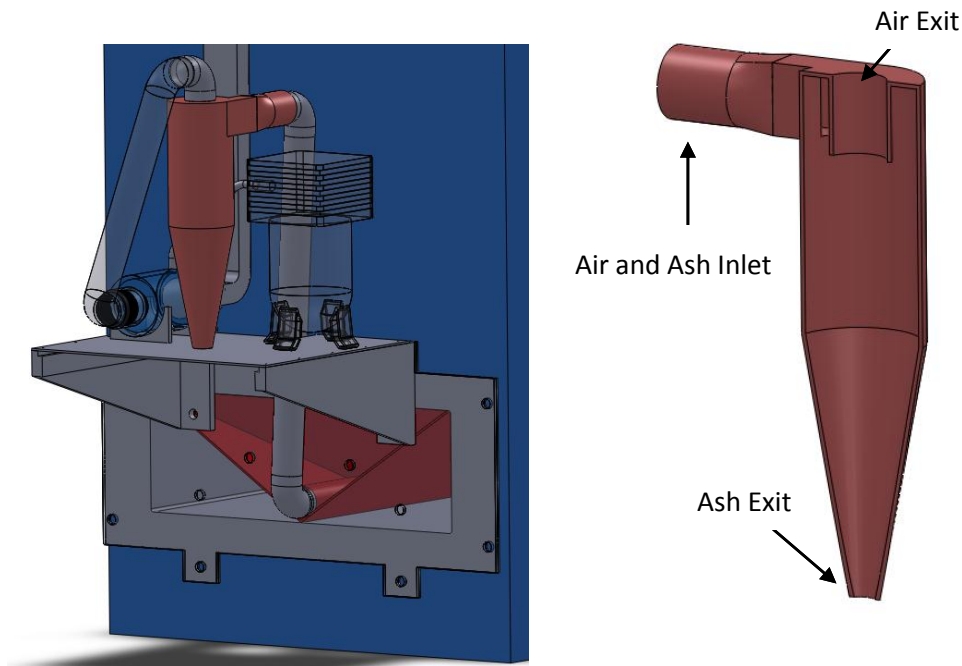

Figure 3.14: Cyclonic Separator

The separated ash falls down into the ash bin below the separator as shown in Figure 3.12, which is held by sliding mounts and can easily be removed. The connection of the bin to

the separator must be sealed to create a vacuum, as otherwise there would be no suction at the end of the piping. The exhaust air from the cyclone travels out of the top and through piping into the vacuum generator, which is powered by the air compressor (shown transparent to the right of the cyclone in Figure 3.14 above). Because some of the smaller particles of ash will not be collected, the generator's exhaust is routed back through the boiler and out its chimney. This is acceptable (as previously discussed) because particles of that size (less than about 20 microns) are already expelled through the chimney during regular operation without ash removal.

4.0 Prototyping and Testing

4.1 Prototyping

Prototypes of both proposed designs were constructed to evaluate their ability to accomplish the desired functions. Due to various restrictions, these prototypes were not constructed from the materials necessary for high temperatures and contact with corrosive ash. Instead, aluminum was used as a primary material for prototyping. Work was primarily done with Computer Numerical Control (CNC) machining and basic shop equipment.

The prototype auger, shown in Figure 4.1 below, was built to evaluate the system's ability to translate ash and fill it upwards into the removal bin. To do this, an aluminum pipe was cut open to form the designed trough feature, allowing ash to be collected. The auger was placed in this pipe and supported on both ends so that its threads had a small amount of clearance from the walls. Next, a pipe (not shown) was welded to the top face of the auger trough to allow ash to be pushed out and into a bin. The specified AC gear motor was purchased and attached to the driving end of the auger with a set screw. To force ash to flow upwards to the removal bin, a section of the auger thread was removed, reversed, and welded back on. This reversed section of the auger is located directly beneath the bin. It is intended to change the direction of the ash flow by compressing ash axially along the auger and allowing it to expand only upwards.



Figure 4.1: Auger Prototype

A cyclonic separator was also prototyped with CNC machining. The funnel section of the cyclone was turned in a lathe and the top sections were created in a mill. These items were press-fit and welded together to create the cyclone prototype shown below in Figure 4.2. All of the designed dimensions were kept in the prototype except for that of the particle inlet. Material and processing restrictions prevented this dimension from being created as designed. This change

may affect the performance of the cyclone, as a larger inlet will require a higher velocity air flow from the vacuum generator.



Figure 4.2: Cyclone System Prototype

Also shown in the figure above is the vacuum generator discussed earlier (blue). This is equipped with an air hose connection to supply compressed air. The cyclone and vacuum generator were connected with clear tubing so that ash traveling inside could be observed. The cyclone was then attached to a bin with screws and silicone sealant to create an air-tight ash receptacle beneath the cyclone (not shown).

4.2 Test Criteria

Test criteria can be generated from the conventional and axiomatic functional requirements. Most generally, we need to evaluate whether or not the design fulfills these requirements. Regardless of the ash transportation method, we will need to observe whether the solution removes ash from surfaces, gathers all ash, and provides for a clean and easy emptying of the ash. This can be done by observation. To ensure that the solution removes ash quickly enough to prevent buildup inside the boiler, we will need to run the removal system for a recorded period of time and record the amount of ash it has removed. We will then compare this rate to the highest rate at which ash might be generated to observe whether the removal system can keep up with ash production.

4.3 Testing Results

Both prototyped ash removal systems were tested outside of the boiler at room temperatures. The high temperature of the system environment was considered at length during the design phase of this project. Testing at room temperature allowed for the use of less expensive materials which are easier to work with for making the prototypes. It is believed that the performance of either system at room temperature represents closely the performance which can be expected with an analogous system made from high temperature materials operating within a hot environment.

When working outside of the boiler, it is difficult to test for the inconsistent nature in which ash collects at the bottom. The ash scrape cycle of the Janfire burner drops relatively large amounts of ash at regular intervals in the same location. Occasionally unburned pellets drop into the bottom of the boiler during the Janfire burner's ash scrape. Also on occasion, though very rarely, poor fuel combustion can result in "clinkers" up to an inch in diameter. Likewise the ash which falls from the flame tubes when they are scraped periodically will build up directly under the flame tubes. The bottom ash not from the burner bowl or flame tube scrapings accumulates more evenly across the bottom of the boiler and is made up of fly ash particles which are too large to be carried out of the combustion chamber with the hot flue gases. Ash that is allowed to build up in the boiler can fuse, forming delicate ash cakes. This makes it difficult to test for all of the variable occurrences that affect the performance of our prototypes.

The ash used to test the devised systems was taken from MESys 6000 and 6000c boilers mated with Janfire NH burners burning premium MESys wood pellets. The ash used for testing contained a small number of unburned pellets. The use of the correct ash was important for these tests, as there is variability in wood ash depending on the both wood fuel itself and the process by which it is combusted.

4.3.1 Auger Test Results

The first test of the auger system failed as the ash was unable to be pushed up and out the discharge, causing it to become tightly packed into the end pipe. This eventually prevented the auger from rotating. Little was known about the capabilities of screw conveyors to discharge vertically with the use of a reversed "kicker" flight. It became apparent through testing that the size of the discharge tube was too small. Because of this, the auger was attempting to compress a

volume of ash into a smaller space. It was unable to do so and eventually could no longer rotate, preventing most of the ash transported by the screw from being discharged.

To remedy this malfunction a larger discharge region was cut into the end of the auger trough. With the larger discharge, ash freely pushed up and out of the trough allowing the auger to rotate easily and run continuously. There is no doubt that the initial failings of the auger were the result of an undersized discharge. Creating a larger discharge for the ash remedied these failings completely.

The ash being pushed up through the discharge occasionally falls back into the auger trough between threads in the auger. To a certain extent this occurrence is inevitable when making use of an upward discharging auger. Lessening the amount of ash which collapses back into the screw after having been discharged will allow for higher performance levels in terms of both energy usage and malfunction rates. This might be accomplished by reducing the pitch of the auger threads, leaving less space for ash to fall.

Ash which collapses back into the auger after having been discharged must be moved again by the screw. This duplication of effort will likely cause the screw conveyor system to operate less efficiently consuming more energy than is necessary. It is also possible, however less likely, that the ash which is allowed to collapse back into the auger trough may eventually work its way behind the reverse thread and bind up the screw conveyor, like the results of the initial test with the smaller discharge.

4.3.2 Vacuum/Cyclone Test Results

The cyclone vacuum system was found to perform less effectively than expected. Most of the ash sucked through the system was blown out through the exhaust with only a fraction of the ash being successfully separated into the bin.

Even with high air velocities provided for by the large TL1500H vacuum generator the cyclonic separator was unable to remove more than half of the ash from the air stream, blowing the rest out through the exhaust. The ash which was removed by the cyclone contained the largest of the ash particles. The ash which was successfully separated and the original bottom ash used for the test looked noticeably different, with the separated ash appearing larger, grittier, and heavier.

There are many possible reasons for the poor performance of the cyclone. For example, the vacuum generator provided air flow rates much higher than were theoretically necessary for

the cyclonic separator to remove all of the particles at or above the mean particle size. The high velocities of the ash particles in the vacuum line may have caused many of the particles to break apart and become smaller than what is easily removed by a cyclone. There was no way to capture the ash which was not removed by the cyclone without adding backpressure to the vacuum line, so the exhaust ash was collected for study.

The flow rate of the vacuum air was not constant at high speeds. At moderate pressure, 70 PSI, the vacuum generator was able to provide a relatively steady air flow as the pneumatic system used was sufficiently large so not to experience a significant pressure drop. However when tested was conducted at high pressure, 90 PSI, the system dropped to moderate pressure levels, 70 PSI, in a matter of seconds. The cyclone performed better at the higher speeds, but larger particles could be noticed in the exhaust air as the pneumatic system dropped in pressure. It is the case that cyclones perform best when air flow rates as well as solid mass flow rates are kept constant. The deceleration of the vacuum air velocity may also have contributed to the cyclone's poor performance.

There was no effort made to meter the introduction of ash into the vacuum because the ash is removed from the bottom of the boiler inconsistently. This is because of the variation of pressure and volumetric flow over the period of operation. When the pump is activated the air pressure is initially at a maximum, but it drops as air is released through the exhaust. Because of this, large quantities of ash are sucked up when the vacuum generator is activated, but smaller amounts are vacuumed after it has been on for some time. It is possible that this may have contributed to the poor performance of the cyclone as well.

5.0 Design Revisions

5.1 Auger System Revisions

Many changes were made to the auger design after testing. It was realized that the auger could be much smaller while still accomplishing the desired functions. The system will require less power from the motor if we avoid filling the bin from the bottom and fighting against the weight of the ash. Main changes are the location and size of the reversed “kicker” thread as well as the ash exit pipe. Redesigning with these modifications allows for a cleaner and simpler removal of the ash bin, as well as a lower power requirement from the motor. Multiple views of the redesigned auger system are shown below in Figure 5.1.

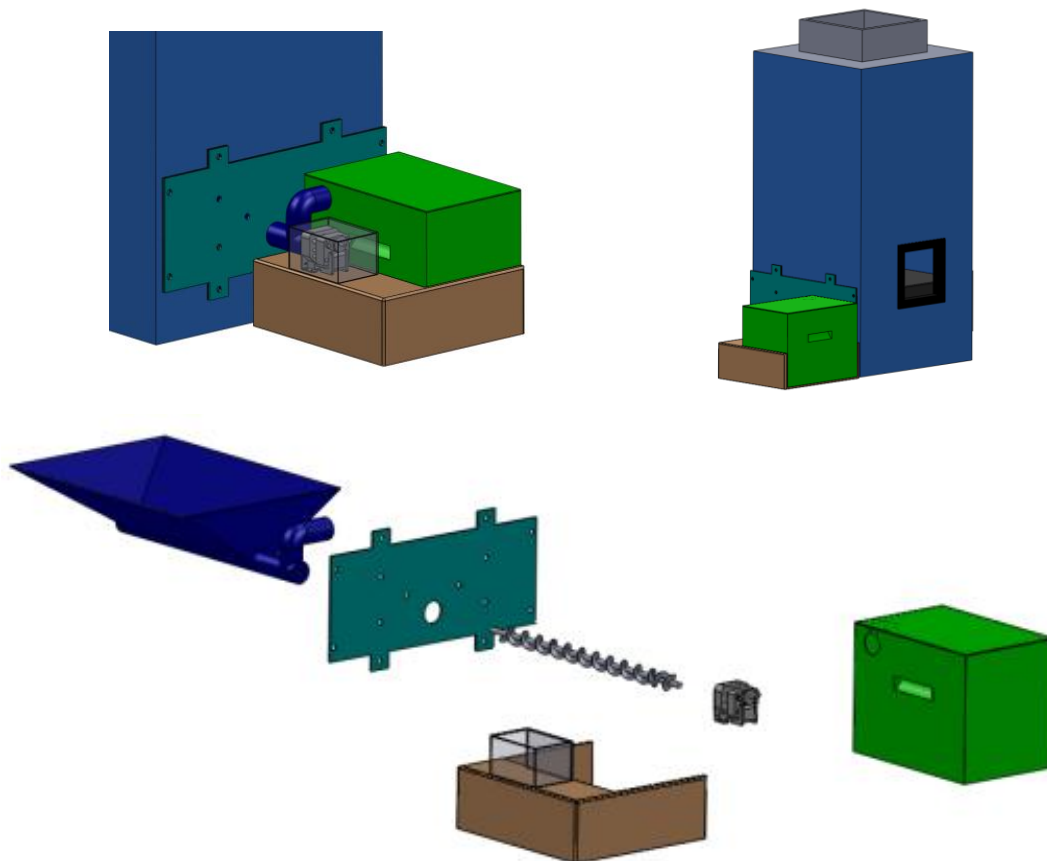

Figure 5.1: Auger System Design

As shown above, the auger draws the ash through a pipe as previously designed, but instead of forcing ash straight up into the bin it forces it up and then sideways into the top of the

bin. Now the auger is no longer opposed by the weight of all of the ash in the bin. The piping that carries ash over the bin is also wider than the pipe that collects ash in the bottom of the boiler. This lessens the forces opposing the auger motor by allowing ash to expand when moving into the wider pipe.

The rearranged piping eliminates the possibility of using the motor's energy consumption to sense when the bin is full. Sensing must now be accomplished by the logic of the Janfire Burner, which can be used to record the amount of pellets that has been burned and calculate the amount of ash that would have been produced. This will be slightly less precise in deciding when the bin is full, as some of the ash may still remain in the boiler or piping.

This design has only a few components and is rather simple. The first is the ash gathering component that sits below the burner and catches the falling ash. This component is shown below in Figure 5.2. The sloped walls gather falling ash and bring it to an open pipe running through the vertex of the sloped surfaces. This pipe contains the auger which pushes the ash out of the boiler as it rotates.

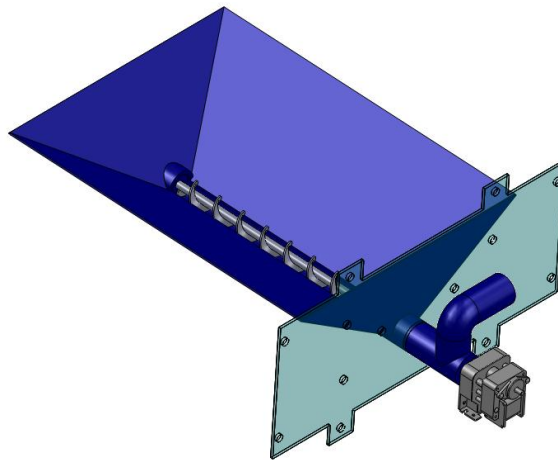

Figure 5.2: Ash Gathering Component

The portion of the component that extends out of the boiler serves to transport ash to the removal bin. The pipe brings ash up then into the side of the bin, filling it from the top. This section of pipe has a wider diameter than the pipe to which it is connected, allowing the ash to flow through more easily than it did in the previous design and prototype. This piece of the design will be constructed from welded iron or heavy steel. Surfaces that are subject to contact with ash will need to be plated with stainless steel to resist corrosion and heat deformation.

Another possible material is aluminized or hot-dipped steel, which has a good resistance to corrosion but is generally more expensive.

The auger is specifically designed for this application and is not a purchased part. It is turned at a low speed with a high torque to slowly move ash from the boiler to the removal bin. The auger is supported at both ends by sealed, corrosion resistant bearings which serve to reduce friction as well as to prevent ash from escaping. Just beneath the pipe that carries the ash to the removal bin, the auger thread is reversed. The threads facing different directions push ash directly towards each other, forcing the ash to move up through the exit pipe. In Figure 5.3 below, a cross section of the auger and ash gathering component shows the reverse thread.

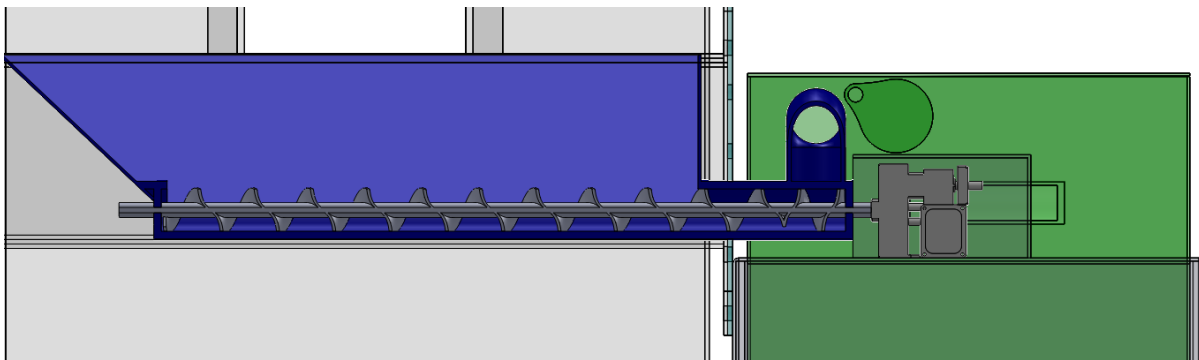

Figure 5.3: Cross Section View of Auger

The bin support feature of the design serves as a footprint to hold the bin and the motor. It contains an empty pocket to hold the bin, allowing it to slide in. This support can be made from a dense plastic, as it is outside the water jacket that surrounds the boiler. The bin support is shown below in Figure 5.4. The support rests on the floor and is bolted to pre-existing holes on the ash compartment door (shown in green below).

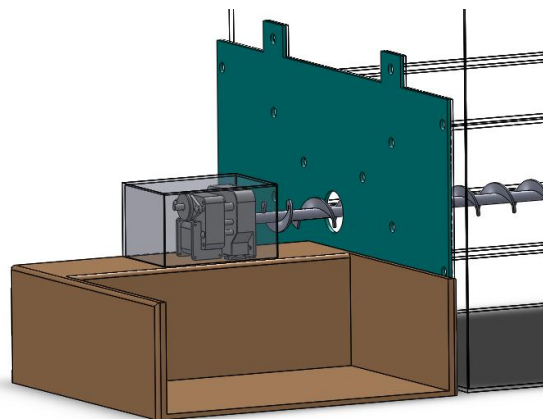

Figure 5.4: Bin Support and Ash Compartment Door

The ash bin is used to store the gathered ash between empty cycles. It is designed to hold 25 lbs of ash before it needs to be dumped and replaced. An opening in the side of the bin (shown in Figure 5.5 below) allows the pipe carrying ash to enter. A spring loaded flap closes off this opening when the bin is removed. The bin is able to slide in and out of the support component, and can be easily grasped by the handles on each side. The top of the bin opens so that ash contained inside may be dumped by the user. The interior of the ash bin must be made from a corrosion resistant material such as stainless steel.

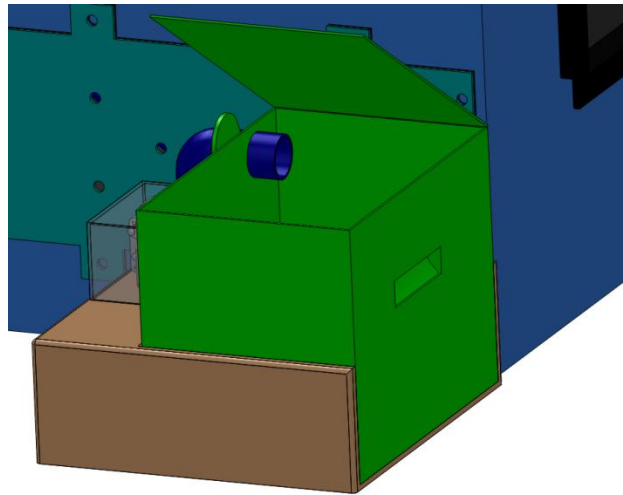

Figure 5.5: Ash Removal Bin

5.2 Vacuum/Cyclone System Revisions

The best method for removing ash from a boiler with a vacuum remains unclear. The poor performance of our cyclonic separator even at very high air flow rates indicates that a conventional cyclone is not well suited for filtering pellet ash. Before further developments are considered for the vacuum removal system, research should be done on the feasibility of such a system and whether there is a better means of removing hot ash from an air stream. Also, the size distribution of the pellet ash should be found experimentally after the ash has been transported in high velocity air flow as it is likely made smaller in vacuum lines.

The performance of a cyclone in removing particles from the air is a function of the air speed. The large vacuum generator used in the prototype system provided massive vacuum air flow (40 SCFM at 90 PSI). This volumetric flow rate requires a more energy than would be practical for a residential application. Using multiple stepped cyclones of different size in series

would allow much higher particle velocities to occur in the smaller cyclone, at a lower volumetric flow rate.

The cyclone built for testing was designed to allow the occasional pellet to pass through without clogging. Ensuring the cyclone inlet was large enough for pellets to pass through required the overall dimensions of the cyclone to be quite large, and the air velocities within the cyclone to be relatively small given the large volumetric flow rate of the vacuum generator. Smaller cyclone(s) could accept the air from the larger cyclone and remove the smaller ash particles, by moving the air at a much higher rate. It is believed that with two staged cyclones the vast majority of wood pellet bottom ash could be removed. A model of this design is shown in Figure 5.6 below. This solution requires compressed air from an outside source, at a higher flow rate and pressure as discussed above.

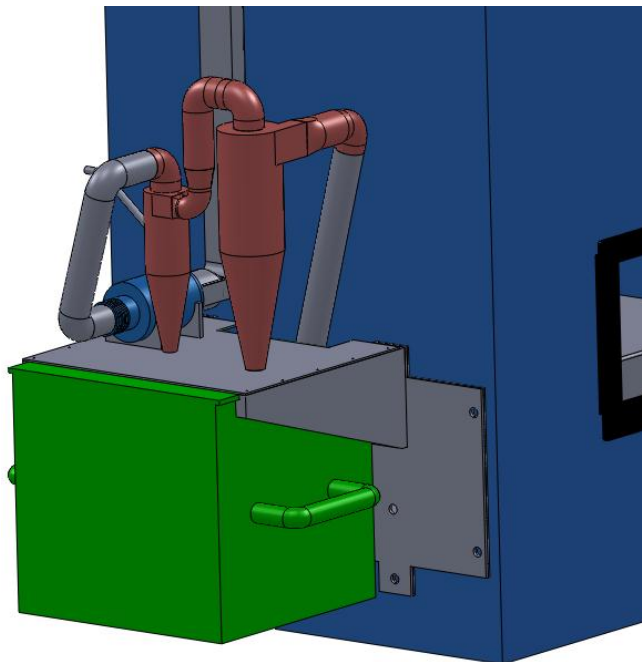

Figure 5.6: Multiple Cyclone System

The cyclone built and tested in this project was designed as a “conventional” cyclone⁵² meaning that neither throughput nor removal efficiency is maximized; instead a conventional cyclone is designed to perform with an adequate removal efficiency rate and moderate pressure loss across the cyclone. It is possible that a high efficiency cyclone which generates greater particle inertial forces would be better suited for pellet ash removal. Future developments of cyclonic wood pellet ash removal will likely need to incorporate high efficiency cyclones. The

pressure losses associated with these cyclones will likely need to be considered; requiring vacuum pumps capable of overcoming these losses while maintaining sufficient suction.

Throughout the course of this project certain advantages of the vacuum system have been realized. Bosch and Maine Energy Systems have discovered that the vast majority of Janfire burner failures are related to the ash scrape cycle. When these failures occur, the bottom of the burner bowl (shown in Figure 5.7 below) which is supposed to slide away dropping the ash from the burner to the bottom of the boiler gets stuck.

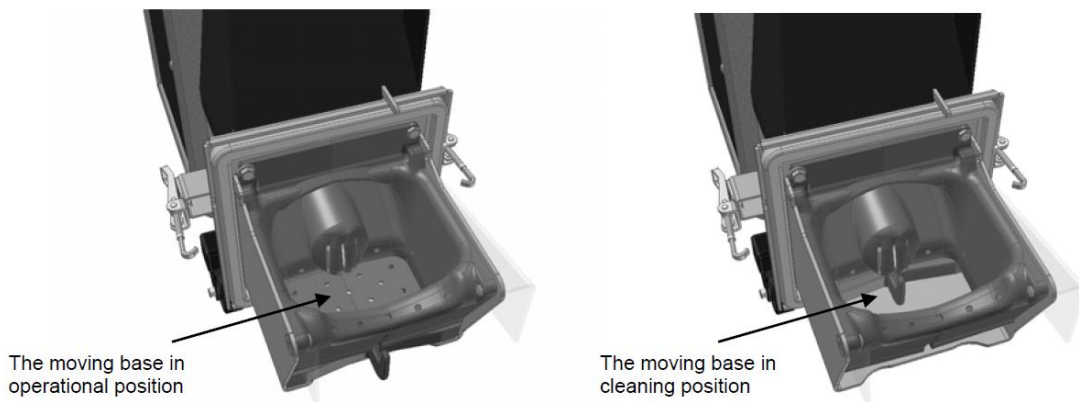

Figure 5.7: Janfire Burner Bowl Scrape Process⁵³

If a vacuum ash removal system were successfully developed, an additional vacuum inlet could be used in place of the ash scrape system which would simply suck the burner bowl ash away at the regular ash scrape intervals. As it happens now the burner must be taken down and cool to a temperature which allows the bottom of the burner bowl to slide away before the ash scrape begins. This can take anywhere from ten to twenty minutes. A vacuum system would likely be able to operate without such a large cooling time. A viable ash removal vacuum solution could allow the Janfire burner to operate more reliably and with less down time for ash removal.

6.0 Conclusions

With escalating economic and environmental costs, the use of petroleum products for residential heat is unsustainable. Transitioning to a sustainable heat source such as wood pellets is continually becoming a more viable option for the North Eastern United States. A transition to wood pellet heating benefits the region, the environment, and the heating consumer. As one of the first companies working to aid in this transition, Maine Energy Systems is looking for ways to make the process more affordable for the home owners. The 6000c boiler will offer hydronic wood pellet heating at a price more akin to that of fuel oil boilers. The purpose of this project was to find a means of automatic ash removal which will allow the 6000c to operate without the need for messy intervention from the home owner.

In order to find the best solution to this problem multiple design methodologies were used extensively. Design axioms and conventional design practices resulted in a conceptual understanding of the required functionality and system constraints which led to robust system designs. A screw conveyor system, or auger, as well as a vacuum and cyclone system were conceived and designed in detail. Currently a number of wood pellet boiler manufacturers use an auger conveyor for ash removal. The vacuum-cyclone system was developed as an innovative solution. Both systems were justified by the same conceptual design process, prototyped and tested. The test results were used to make recommendations to Maine Energy Systems on the merits of each system and the possible application in their products.

It was found that a combination of design methods is beneficial when faced with a design problem. The systematic approach of design axioms helps to ensure that the simplest design accomplishing all of the functional requirements is realized. Ideation techniques also provide a multitude of potential solutions, both conventional and unorthodox, creating a rich basis from which a final design may be selected. The combined use of various design techniques has led us to solid recommendations to aid MESys in their work to support the increasing use of wood pellets as a heating solution.

7.0 Recommendations

Recommendations have been made to help Maine Energy Systems offer a product which will aid in the transition from petroleum heating. The need for an inexpensive wood pellet boiler for hydronic heating led MESys to develop the 6000c boiler, and it is because of this that cost as well as functionality is considered in the making of this recommendation.

Although little attention was given to a simple tray design in this project, our design methods have shown that it should be pursued initially by MESys for their 6000c boiler. Designing a tray with a removable lid would be sufficient so that a lid can slide on top, sealing the ash before it is removed from the boiler. This small change in the 6000c would prevent the home owner from having to shovel out ash manually, and would make emptying the boiler a much cleaner chore, although still not a job one should do with their good clothes on. Many homeowners making the transition to wood pellet heat, however will eventually desire a solution for ash removal which keeps them entirely clean.

The designed auger conveyor system could be made to work as a completely clean solution for ash removal. The prototype system worked well during testing and is supported by robust design methods and axioms. The revised design included in this report should be used as a starting point for an automatic ash removal system for the 6000c. Further work on the screw conveyor should focus on the most efficient and robust positioning of the discharge and reverse flight. Both horizontal and vertical flight pitch dimensions can be substantially smaller than those on the prototype as only a small amount of ash needs to be transported in order to keep up with ash production. The auger motor should also have a slower rotational velocity in order to provide greater torque at the same amount of power usage. Again this is because of the small amount of ash production. Higher torque from the motor would prevent small clogs in the discharge from binding the screw conveyor and stopping its rotation.

Further development of a vacuum ash removal system is likely to be fruitful as well, although it is not likely to be quickly and easily developed for production. If advances are made which allow for the sufficient filtering of hot ash from a vacuum flow, it is possible that the Janfire burner would benefit from such a system by replacing the troublesome mechanical ash scrape system with a burner bowl vacuum. It would be beneficial for both MESys and Janfire to work together on developing an ash removal vacuum. The reasons for the unsatisfactory performance of the prototype cyclone are as of yet not fully understood. Cyclonic separator

theory supports far better performance than was found during this study. Removal of ash sized particles may require high efficiency cyclones built precisely to tighter tolerances than the prototype built for this project.

References

- ¹ (Dresser, Dutch) Maine Energy Systems, 9-2010
- ² Egger et al., Biomass Heating in Upper Austria: Green Energy, Green Jobs. O.O. Energiesparverband, 2011
- ³ U.S. Energy Information Administration, 10-7-2010
- ⁴ US Census Residential Energy Survey, Northeast Census Region, 1997
- ⁵ Maine Energy Systems. "Our Mission" Accessed 25 September 2010.
<http://www.maineenergysystems.com/our_mission.htm>
- ⁶ Your Next Boiler will Burn Wood Pellets, Maine Energy Systems Brochure, 2011
- ⁷ Maine Forest Service Assessment of Sustainable Biomass Availability: 17 July, 2008
- ⁸ Strauss, Bill. The Governor's Wood-to-Energy Task Force Report, State of Maine, Appendix C
- Wood Pellet Fuel Costs in Detail: 33-34, 10-2008
- ⁹ Maine Energy Systems. "Our Mission" Accessed 25 September 2010.
<http://www.maineenergysystems.com/our_mission.htm>
- ¹⁰ (Dresser, Dutch) Maine Energy Systems, 9-2010
- ¹¹ Operating Instructions, Janfire NH/Inetgral Pellets Burner with External Auger: Janfire, 2007
- ¹² Operating Instructions, Janfire NH/Inetgral Pellets Burner with External Auger: Janfire, 2007
- ¹³ Operating Instructions, Janfire NH/Inetgral Pellets Burner with External Auger: Janfire, 2007
- ¹⁴ (Dresser, Dutch) Maine Energy Systems, 9-2010
- ¹⁵ (Dresser, Dutch) Maine Energy Systems, 3-2011
- ¹⁶ Suh, *The Principles of Design*, Oxford University Press, 1990
- ¹⁷ Norton, Robert L. *Design of Machinery: An Introduction to the Synthesis and Analysis of Mechanisms and Machines*. Dubuque, IA: McGraw-Hill, 2008. Print
- ¹⁸ Norton, Robert L. *Design of Machinery: An Introduction to the Synthesis and Analysis of Mechanisms and Machines*. Dubuque, IA: McGraw-Hill, 2008. Print.
- ¹⁹ Norton, Robert L. *Design of Machinery: An Introduction to the Synthesis and Analysis of Mechanisms and Machines*. Dubuque, IA: McGraw-Hill, 2008. Print.
- ²⁰ Pahl, G. and Beitz, W. *Engineering Design: A Systematic Approach*. Print. 2003.
- ²¹ Norton, Robert L. *Design of Machinery: An Introduction to the Synthesis and Analysis of Mechanisms and Machines*. Dubuque, IA: McGraw-Hill, 2008. Print.

- ²² Norton, Robert L. Design of Machinery: An Introduction to the Synthesis and Analysis of Mechanisms and Machines. Dubuque, IA: McGraw-Hill, 2008. Print.
- ²³ PES 12-56 Pellet Boiler Operating Manual v1.0, Okofen, 10-2009
- ²⁴ Kozlusan Online Website. Biomass (Wood Pellet) Boilers. Accessed 19 October, 2010
<kozlusan.com>
- ²⁵ (Dresser, Dutch) Maine Energy Systems, 9-2010
- ²⁶ PES 12-56 Pellet Boiler Operating Manual v1.0, Okofen, 10-2009
- ²⁷ PES 12-56 Pellet Boiler Operating Manual v1.0, Okofen, 10-2009
- ²⁸ Pellet Fuels Institute Standard Specification for Residential/Commercial Densified Fuel, October 25, 2010
- ²⁹ Pahl, G. and Beitz, W. Engineering Design: A Systematic Approach. Print. 2003.
- ³⁰ Pahl, G. and Beitz, W. Engineering Design: A Systematic Approach. Print. 2003.
- ³¹ Kulweic, Raymond A. Materials Handling Handbook. Print, John Wiley and Sons, Inc. 1985
- ³² Kulweic, Raymond A. Materials Handling Handbook. Print, John Wiley and Sons, Inc. 1985
Table 26.1.16
- ³³ Kulweic, Raymond A. Materials Handling Handbook. Print, John Wiley and Sons, Inc. 1985
Table 26.1.7
- ³⁴ Kulweic, Raymond A. Materials Handling Handbook. Print, John Wiley and Sons, Inc. 1985
Table 26.1.9
- ³⁵ Kulweic, Raymond A. Materials Handling Handbook. Print, John Wiley and Sons, Inc. 1985
Table 26.1.3
- ³⁶ Kulweic, Raymond A. Materials Handling Handbook. Print, John Wiley and Sons, Inc. 1985
Table 26.1.10
- ³⁷ Kulweic, Raymond A. Materials Handling Handbook. Print, John Wiley and Sons, Inc. 1985
Table 26.1.11
- ³⁸ Kulweic, Raymond A. Materials Handling Handbook. Print, John Wiley and Sons, Inc. 1985
Table 26.1.1
- ³⁹ McMaster Carr. Online Catalogue. Part Number 6142K42.
<<http://www.mcmaster.com/#ac-gearmotors/=c0mnod>>
- ⁴⁰ Mihelcic, James R, Zimmerman, Julie B, and Auer, Martin T. Environmental Engineering:

Fundamentals, Sustainability, Design. 2010. Print.

- ⁴¹ Cooper, C. and Alley, F. Air Pollution Control: A Design Approach. Waveland Press, Inc. Print. 1986.
- ⁴² Cooper, C. and Alley, F. Air Pollution Control: A Design Approach. Waveland Press, Inc. Print. 1986.
- ⁴³ Cooper, C. and Alley, F. Air Pollution Control: A Design Approach. Waveland Press, Inc. Print. 1986.
- ⁴⁴ Dahl, Olli; Nurmesniemi, Hannu; Pöykiö, Risto; Watkins, Gary. “Comparison of the characteristics of bottom ash and fly ash from a medium-size (32 MW) municipal district heating plant incinerating forest residues and peat in a fluidized-bed boiler” Fuel Processing Technology. 20 April, 2009.
- ⁴⁵ “TDSS Stainless Steel Vacuum Pumps” 2009. Air-Vac. 5 February 2011, <<http://airvacpumps.com/TDSSpump.htm>>
- ⁴⁶ “TDSS Stainless Steel Vacuum Pumps” 2009. Air-Vac. 5 February 2011, <<http://airvacpumps.com/TDSSpump.htm>>
- ⁴⁷ Air-Vac. TDRH Series Data Sheet. < <http://airvacpumps.com/pdfs/td.pdf>> Accessed 18 January, 2011.
- ⁴⁸ Air-Vac. TDRH Series Data Sheet. < <http://airvacpumps.com/pdfs/td.pdf>> Accessed 18 January, 2011
- ⁴⁹ Fundamentals of Heat and Mass Transfer 6e, Incropera, Eq 7.38
- ⁵⁰ Fundamentals of Heat and Mass Transfer 6e, Incropera, Eq 7.39
- ⁵¹ Fundamentals of Heat and Mass Transfer 6e, Incropera, Eq 5.6
- ⁵² Cooper, C. and Alley, F. Air Pollution Control: A Design Approach. 1986. Print.
- ⁵³ Operating Instructions, Janfire NH/Integral Pellets Burner with External Auger: Janfire, 2007