



Development of a Test Rig for Tribological Evaluation of Sliding Bearings in Saline Water

14/12/2023

Alexander, Rohit, Ricardo, Numan and Florian

Table of content

0. Reminders
1. Intermediate design
2. Design Review
3. Proof of concepts
4. Testing procedure
5. Results and future work



Figure 1: Tidal turbine illustration

0. Reminders – Context

Green energy

Underwater tribology

Turbine failure



Figure 2: Tidal turbine illustration

0. Reminders – Context

Green energy

Underwater tribology

Turbine failure



Figure 2: Tidal turbine illustration

↳ Need for a test rig to evaluate tribological performances of components under seawater

0. Reminders – Test rig objectives

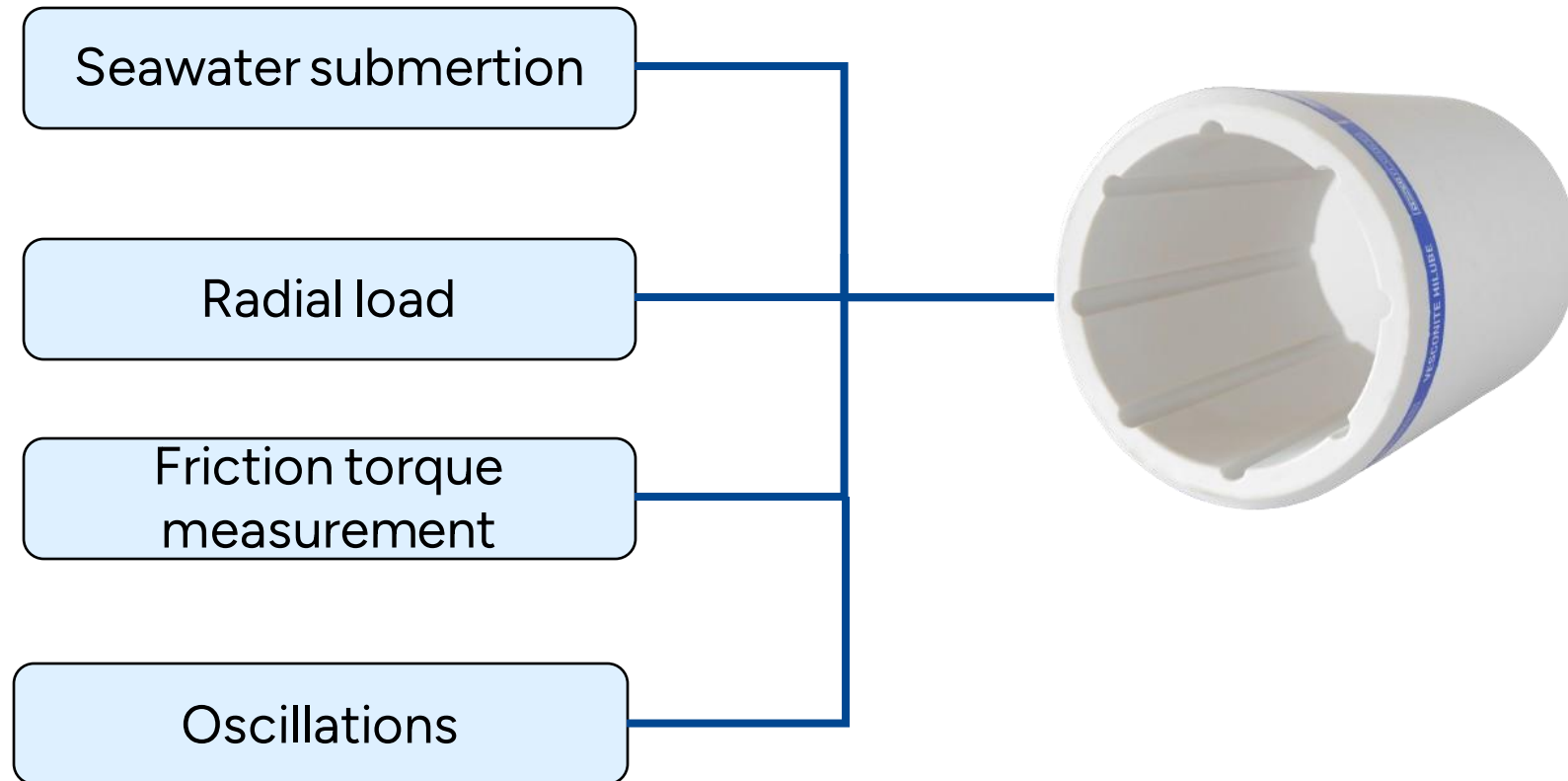

0. Reminders – Main Requirements



Radial load

The tested bearing is under radial load

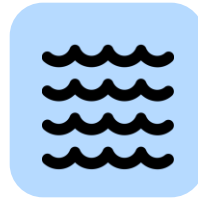

Seawater submersion

The tested bearing is fully submerged in seawater



Friction measurement

The friction inside the tested bearing is measured and saved

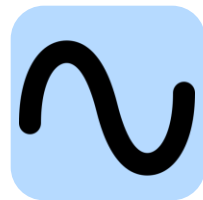

Oscillations

The bearing is excited with oscillations with controlled amplitude and frequency

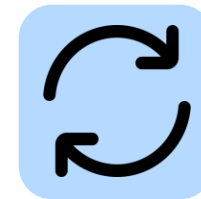

Reuse a test-rig

The main components of an old journal test test-rig are reused

0. Reminders – Reused system

Radial load system

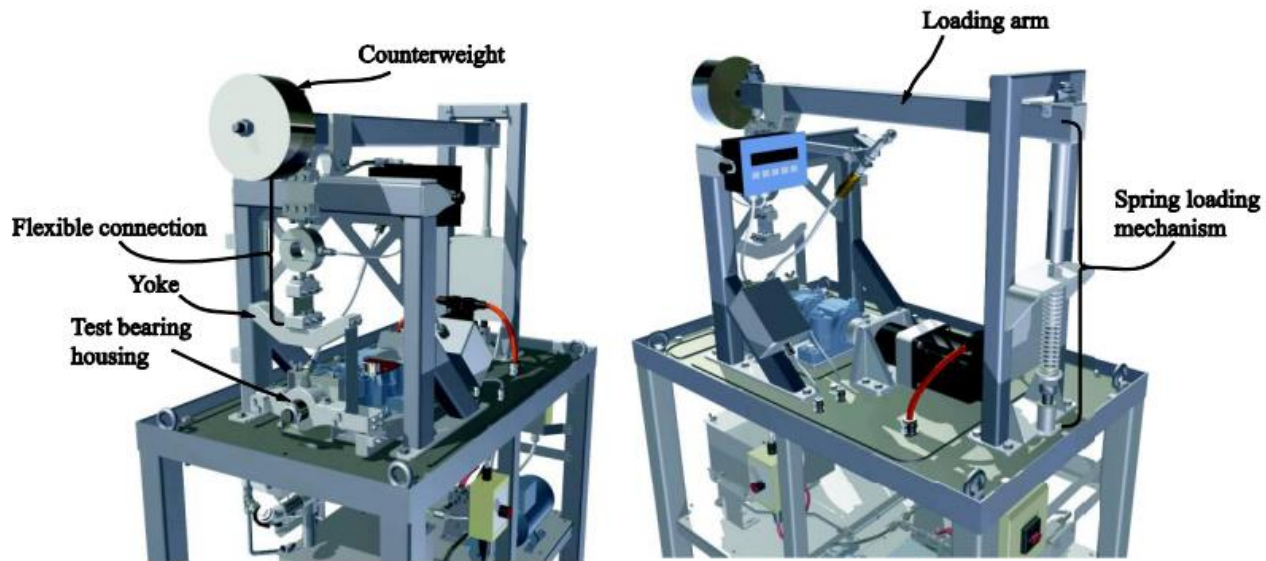

Figure 3: Radial load system

Vertical load applied up to 5kN

Power chain

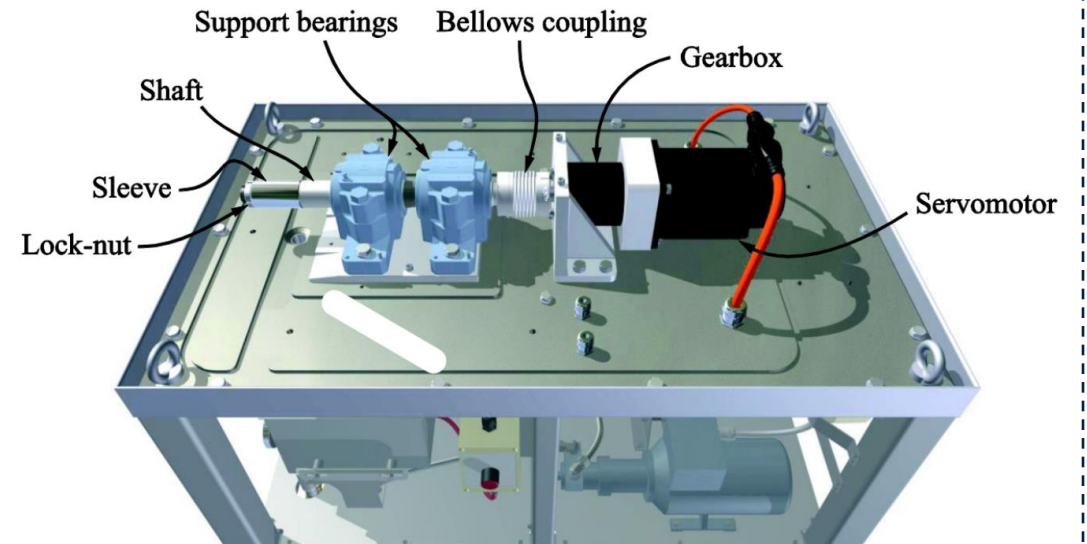
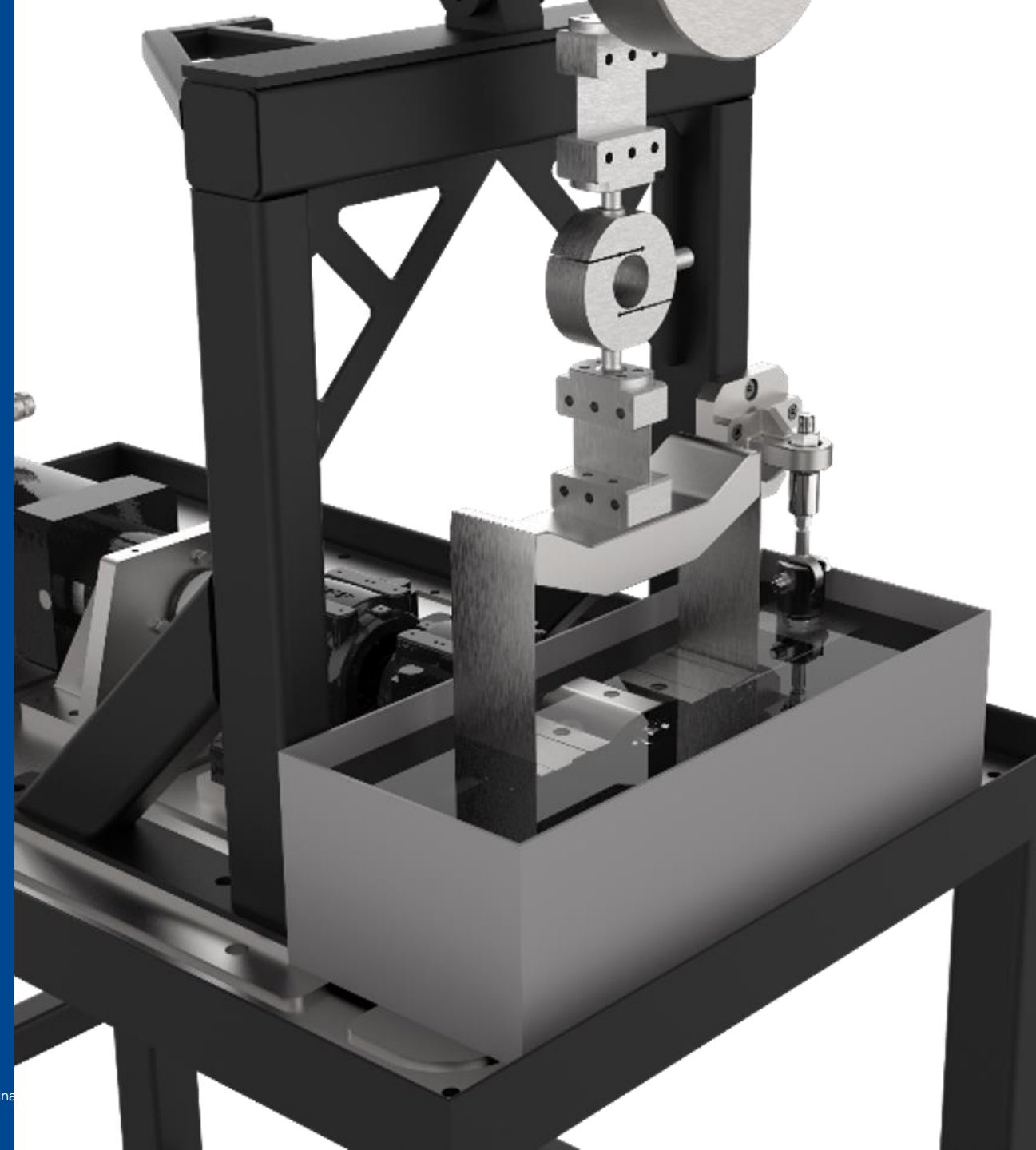

Figure 4: Power chain

A coupler and two support bearings

1. Intermediate designs

Intermediate concepts and why they have been dismissed.



1. Intermediate designs

Design 1 : Underwater load cell

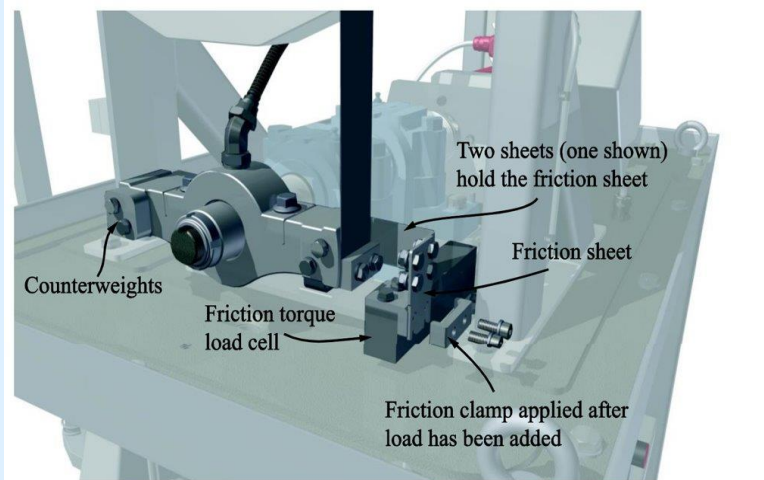

Similar concept to the former test rig.

↳ **Underwater load cells are very expensive and their performances are unknown in seawater**

Design 2 : One side load cell

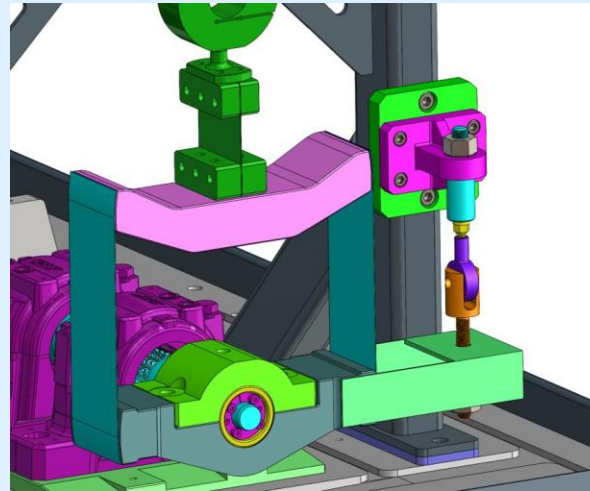

The load cell is shifted outside of the water.

↳ **Sensor preload impossible with this design**

Design 3 : Beam load cells

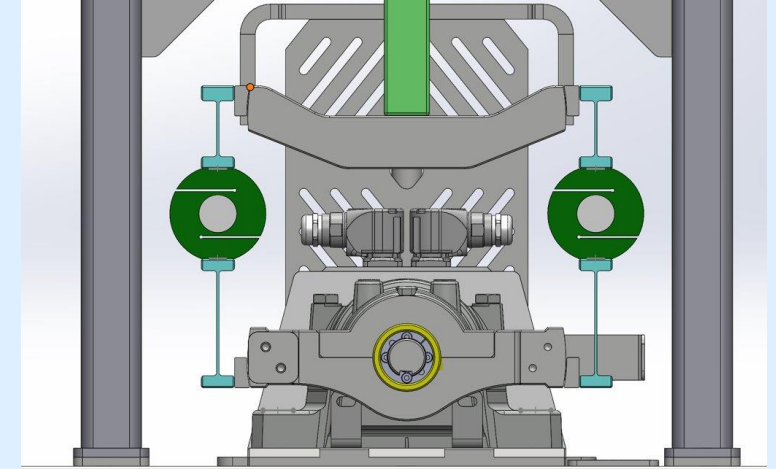

The load is measured by the difference between the load cells.

↳ **The load cells should have larger bandwidth to accommodate high load (radial load) and low loads from the (friction torque)**

2. Final design

Concept implemented and its subsystems

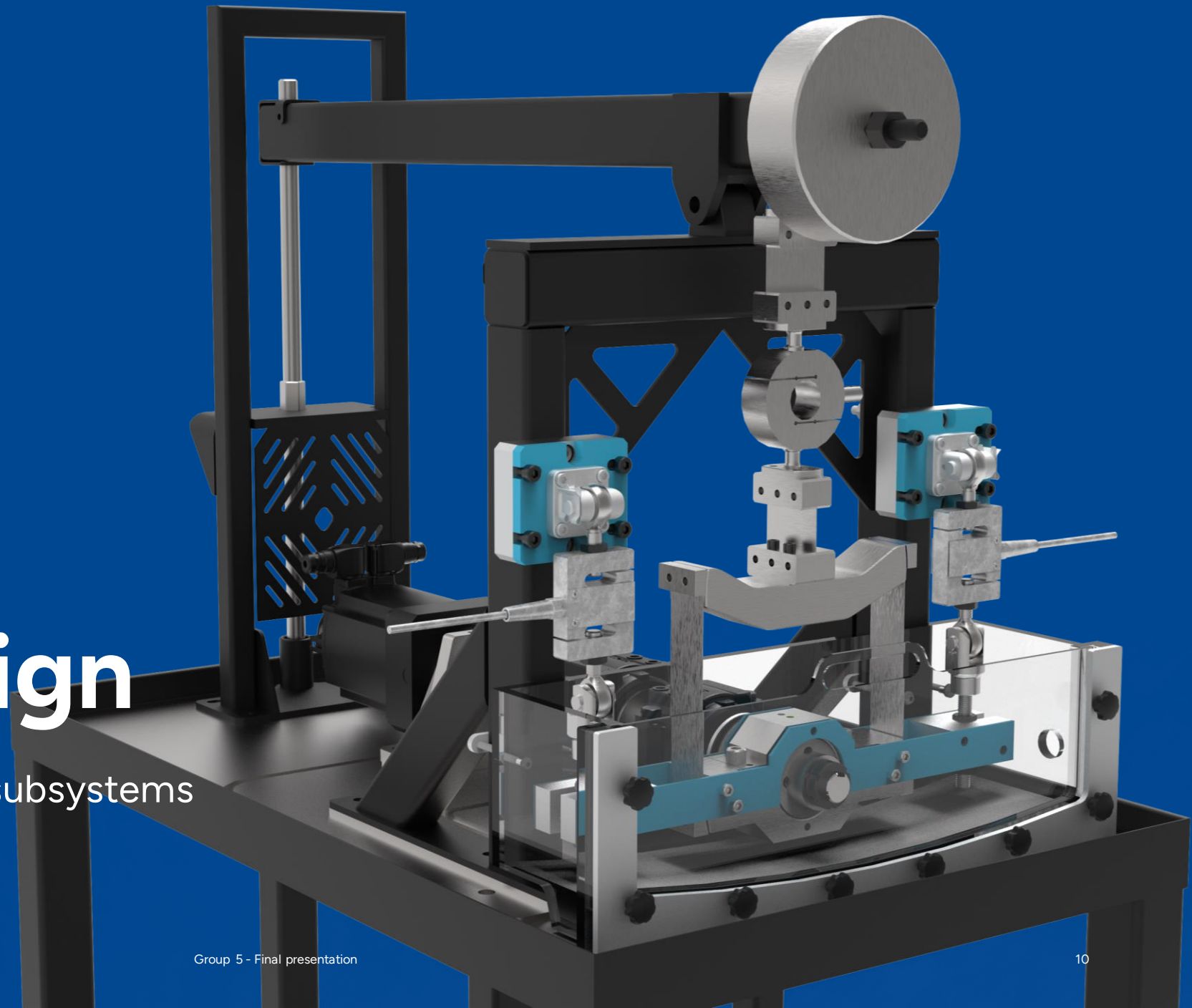

2. Design review

- The bearing is preloaded by pulling the housing up applying pressure
- To allow for self alignment of the bearing and the housing the housing is supported by flexible steel sheets
- The sheets don't perturbate the measurement
- The friction causes the housing to tilt which imposes a force on the sensors
- Friction is the sum of the friction load cells

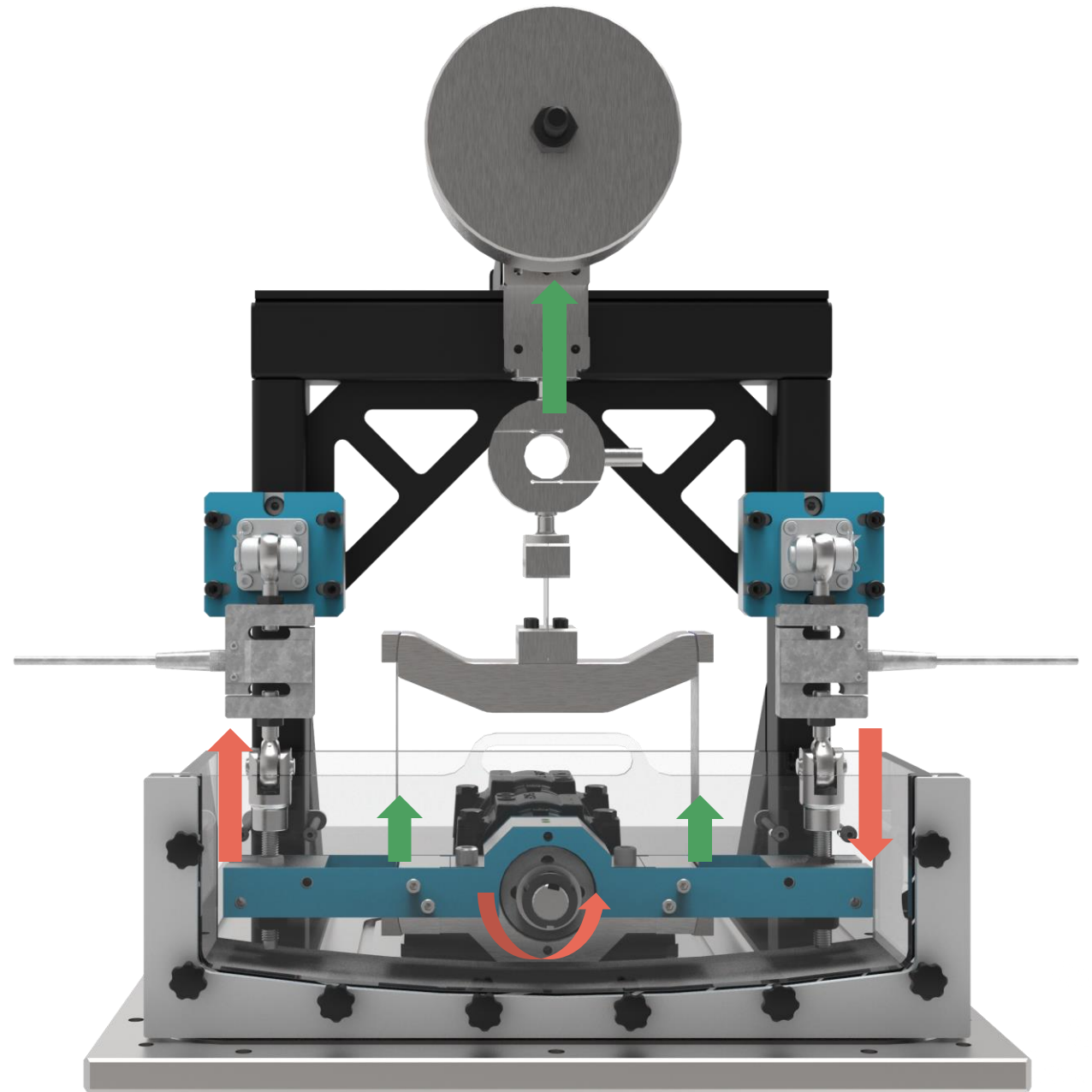

Figure 8: Friction measure and radial load

2. Design review

2.1 Fiction Sensor Assembly

- The friction sensor assembly aims to keep the load vertical in the sensor
- Rod ends allows for the assembly to tilt back and forth and rotate about the axis
- The threaded rods allow for vertical alignment
- Slots are used to allow for the horizontal alignment
- The friction sensor is preloaded by turning the lower nut in turn pulling the sensor down

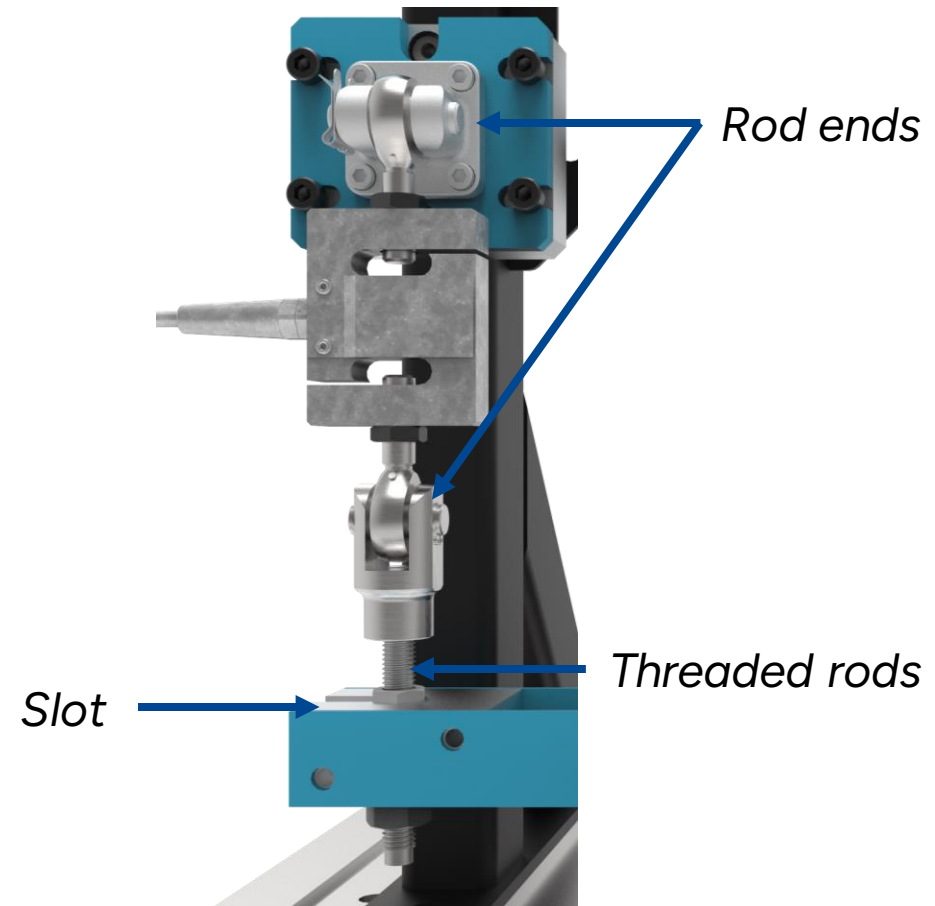
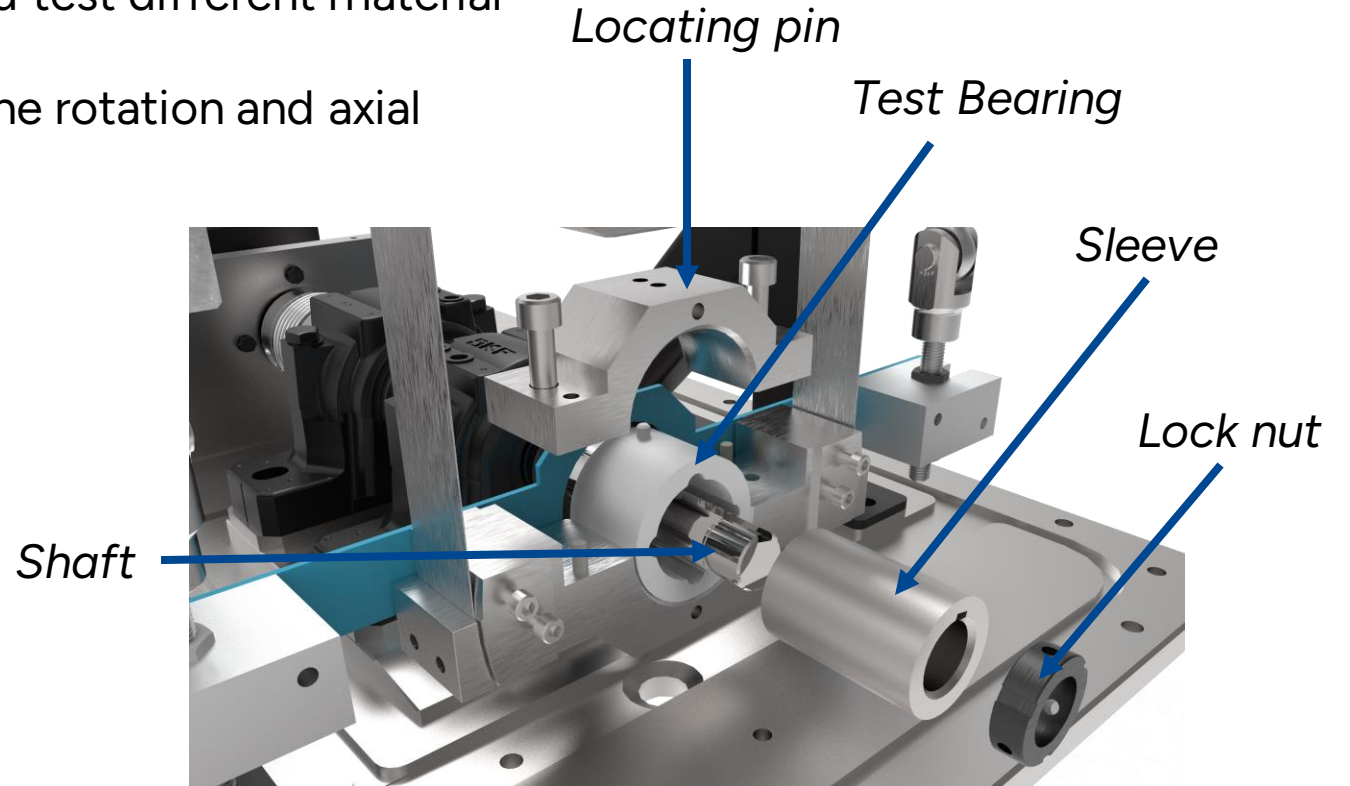
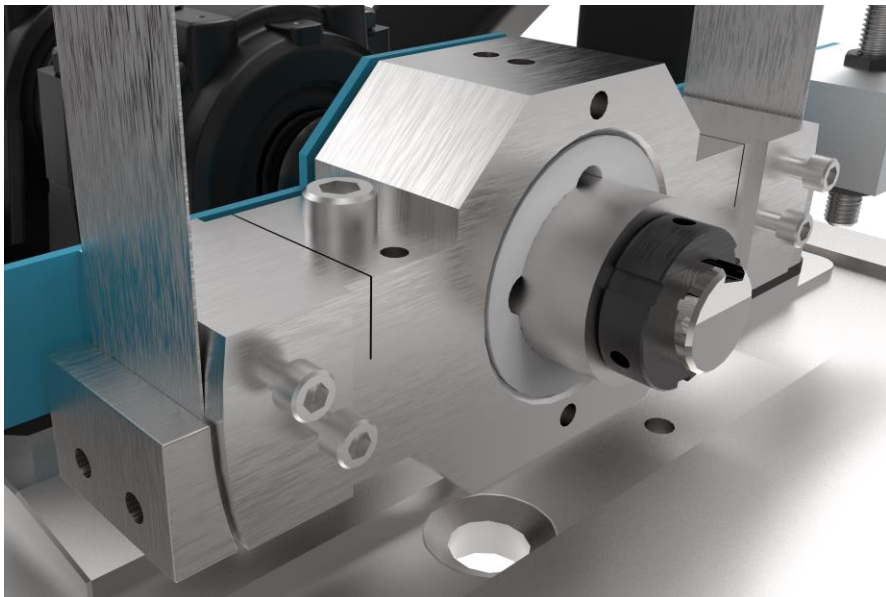

Figure 9: Load cell assembly

2. Design review

2.2 Shaft and Sleeve

- Split housing allows ease of assembly and disassembly
- Sleeve introduces flexibility to choose and test different material combinations
- Locating pins on the bearing to prevent the rotation and axial motion of the bearing



2. Design review

2.3 Water Tank Assembly

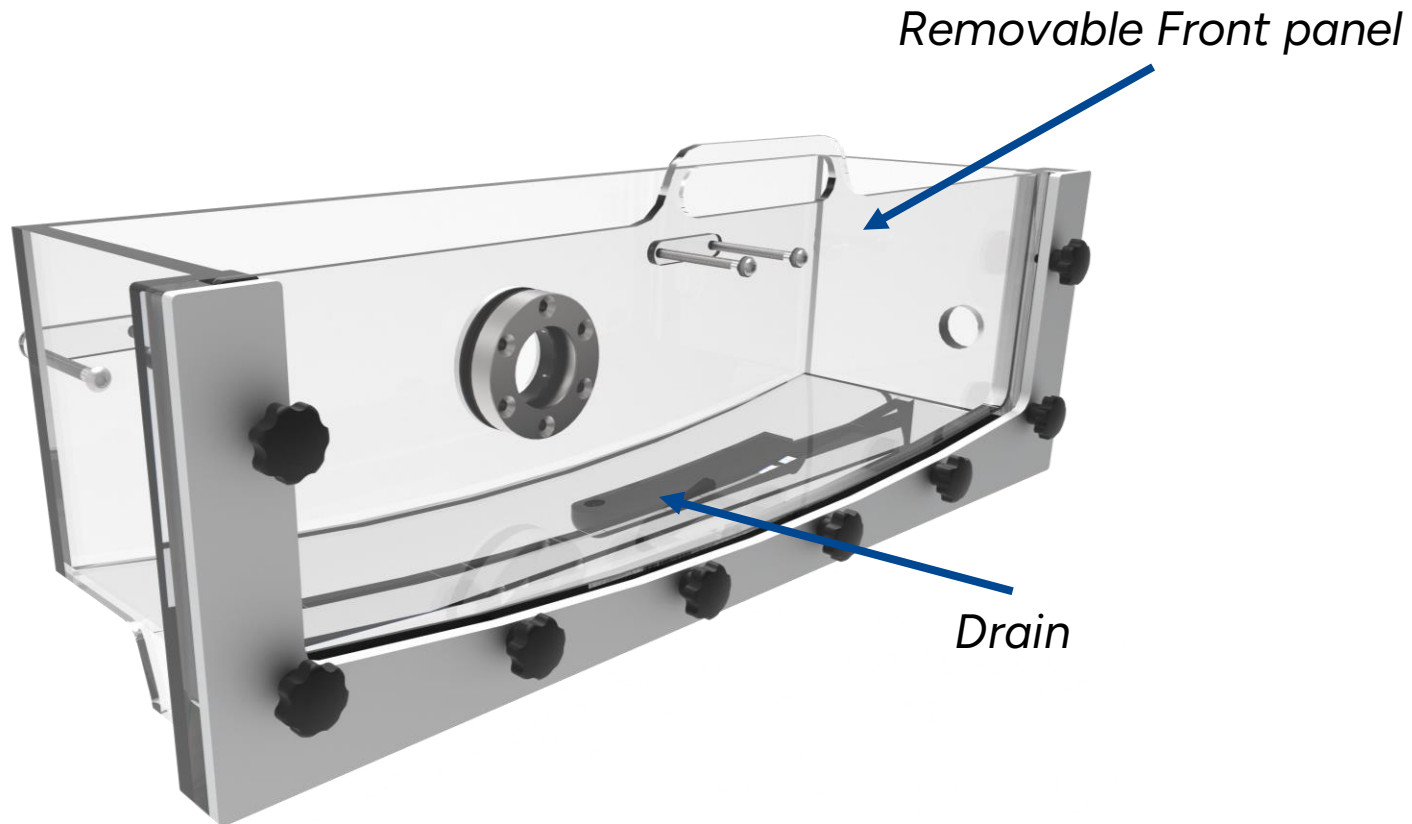

Single Radial Oil seal

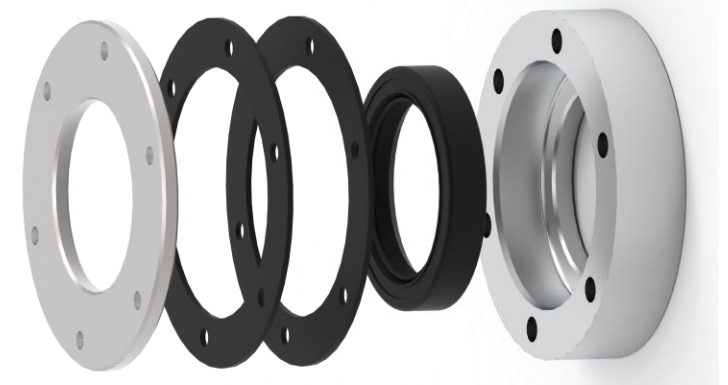

3. Proof of concept

Machine assembly

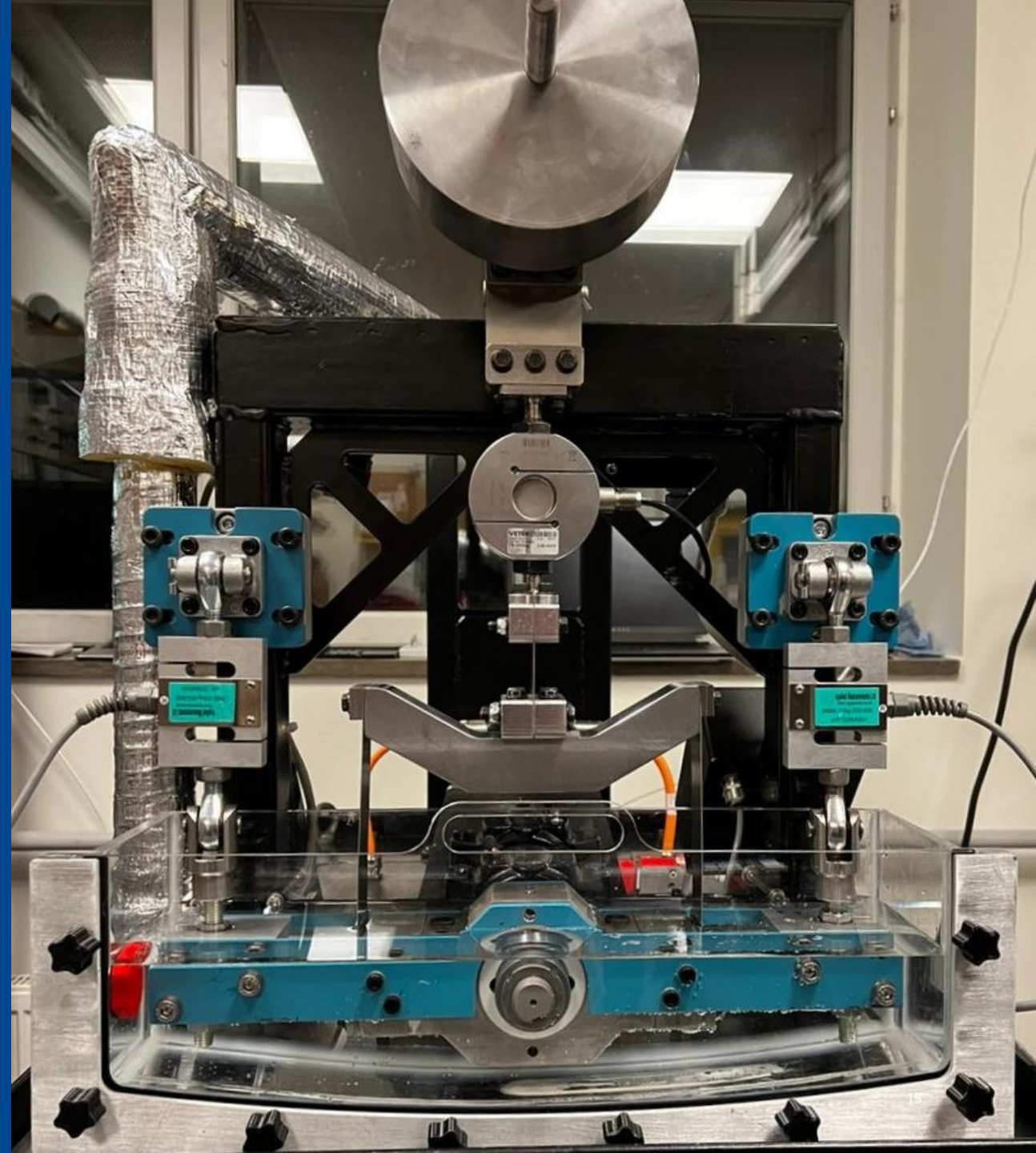

3. Proof of Concept

Challenge

Delivery estimates for manufacturing of the stainless-steel shaft exceeded the timeframe of our project.

Solution

- Prototype utilizes an existing shaft and most components from the final design
- A temporary steel sleeve was manufactured to adapt this shaft
- Can still test Vesconite bearings
- Provides validation of concept without investing in a new stainless-steel shaft.

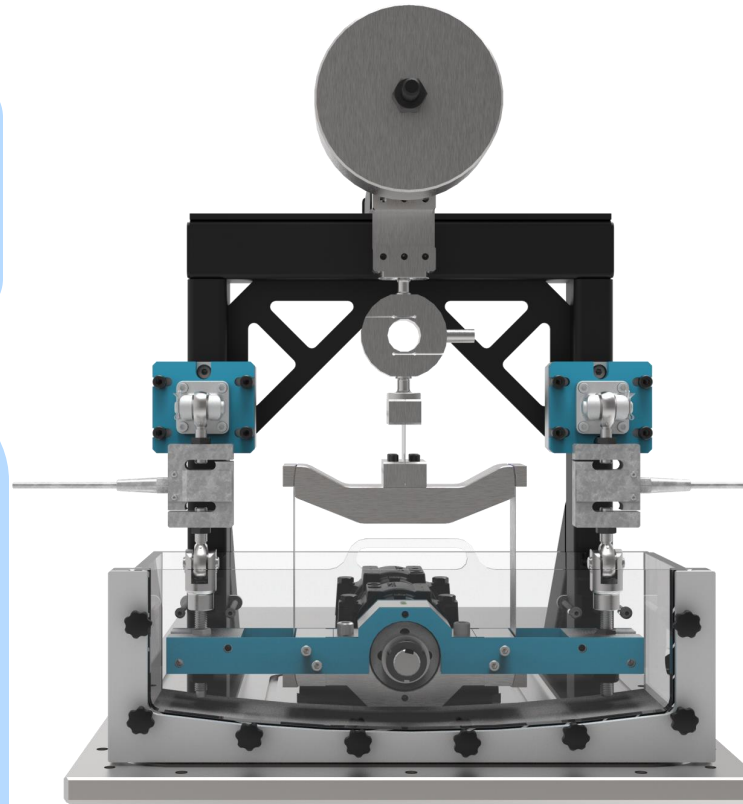

Rendered Image

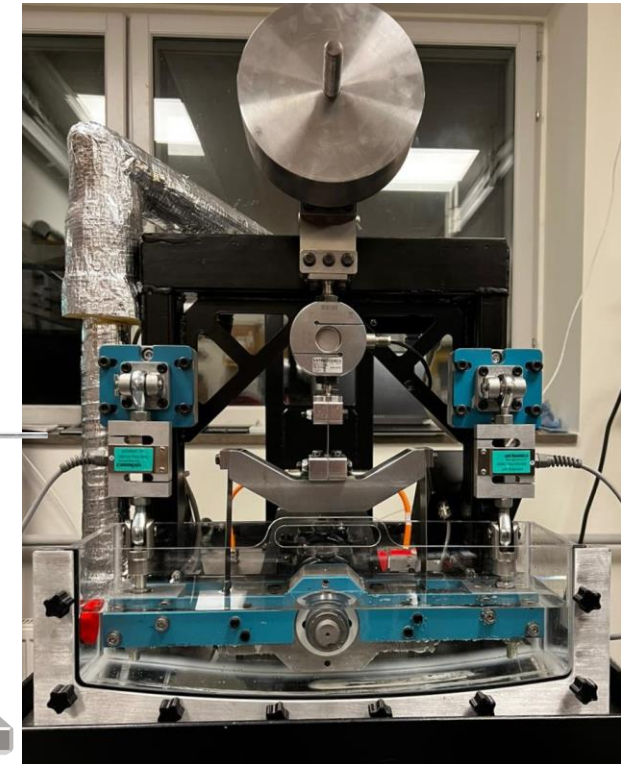

Assembled Rig

3. Proof of Concept – Manufacturing

- Parts were manufactured in-house, off the shelf, or from a manufacturer in Germany
- In-housing manufacturing of the water tank
- Some submergible parts which were made of steel were painted to prevent corrosion
- Origin of the parts: South Africa (Vesconite Bearings), Germany (CNC Machining), UK (Load Cells), Sweden, etc.

Water Tank



Stainless steel parts
manufactured in Germany



3. Proof of Concept – Assembly

- SKF assembly guidelines were followed strictly to assemble the support bearings
- All the necessary measures were ensured to avoid contamination of the grease
- A sweep test was performed after the assembly to ensure that the run-out of the shaft was within the limits

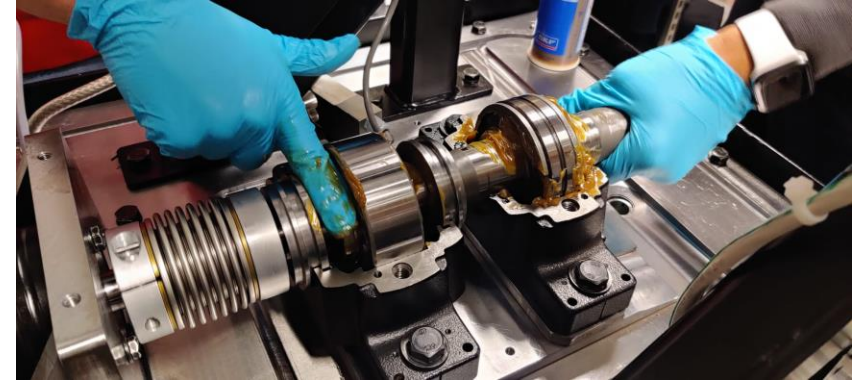

Assembly of support bearings

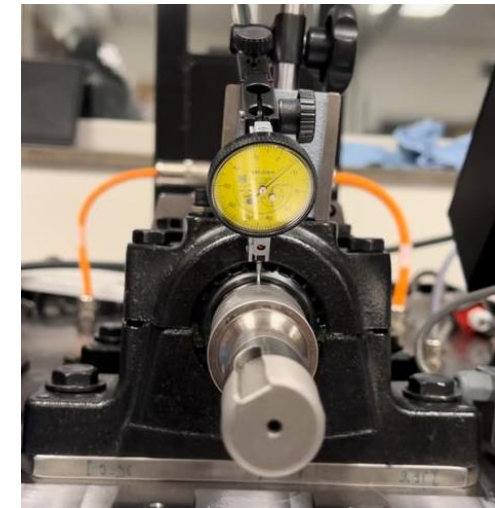

Sweep test- To check the Run-out of the shaft

3. Proof of Concept – Assembly

Our team utilised several 3D prints throughout the assembly process to save time and solve problems

Examples include:

- Replica Load Cells
- Temporary sliding bearings
- Calibration tool
- Tank drainpipe



3. Proof of Concept

Motor Control Software - IndraWorks

- Constant speed profile
- Reciprocating movement profile
- Torque control
- Maximum Shaft Speed: 1200 rpm
- Maximum Shaft Torque: 75 Nm

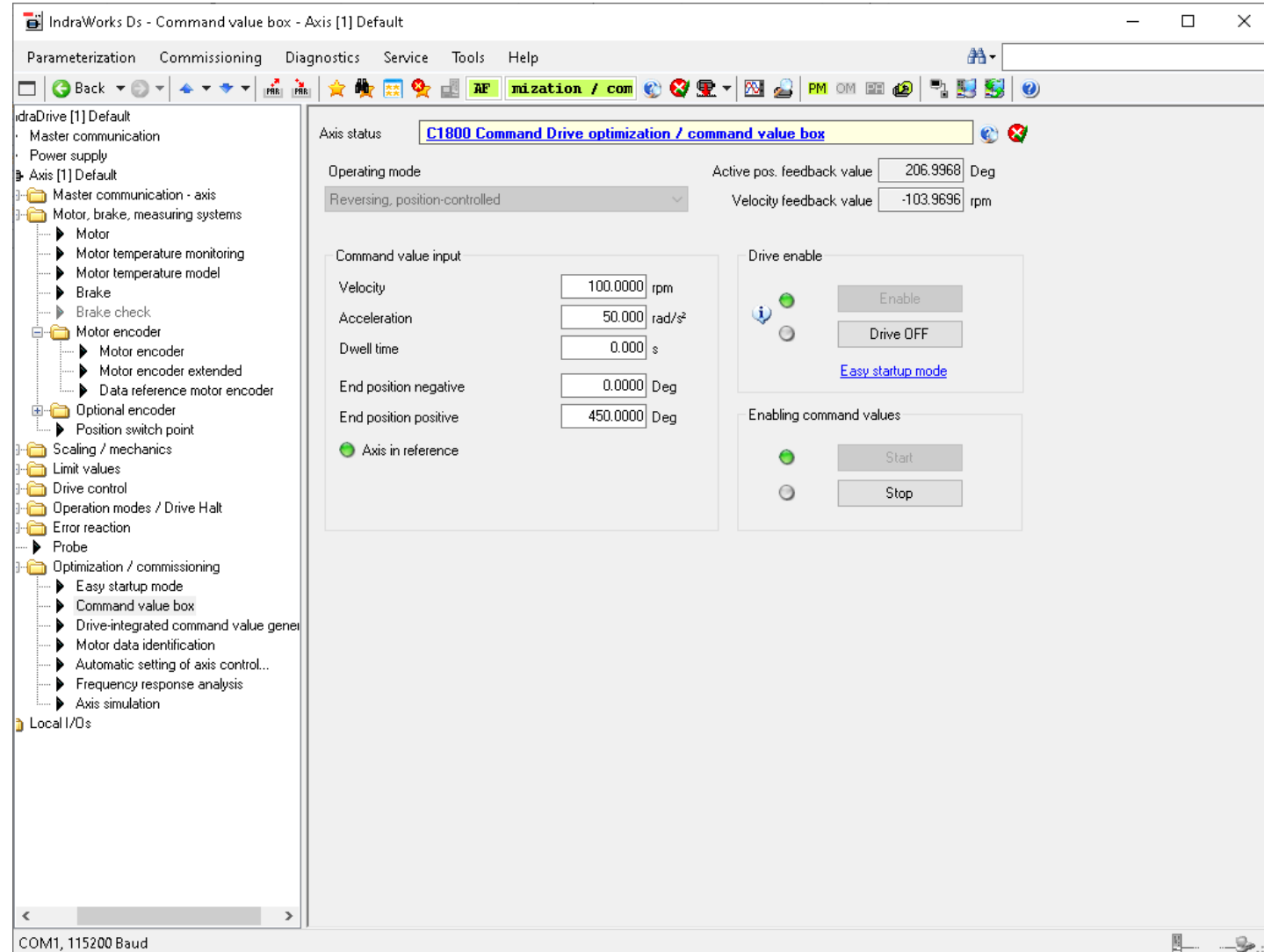

3. Proof of Concept

- Data Acquisition System – LabView 2018

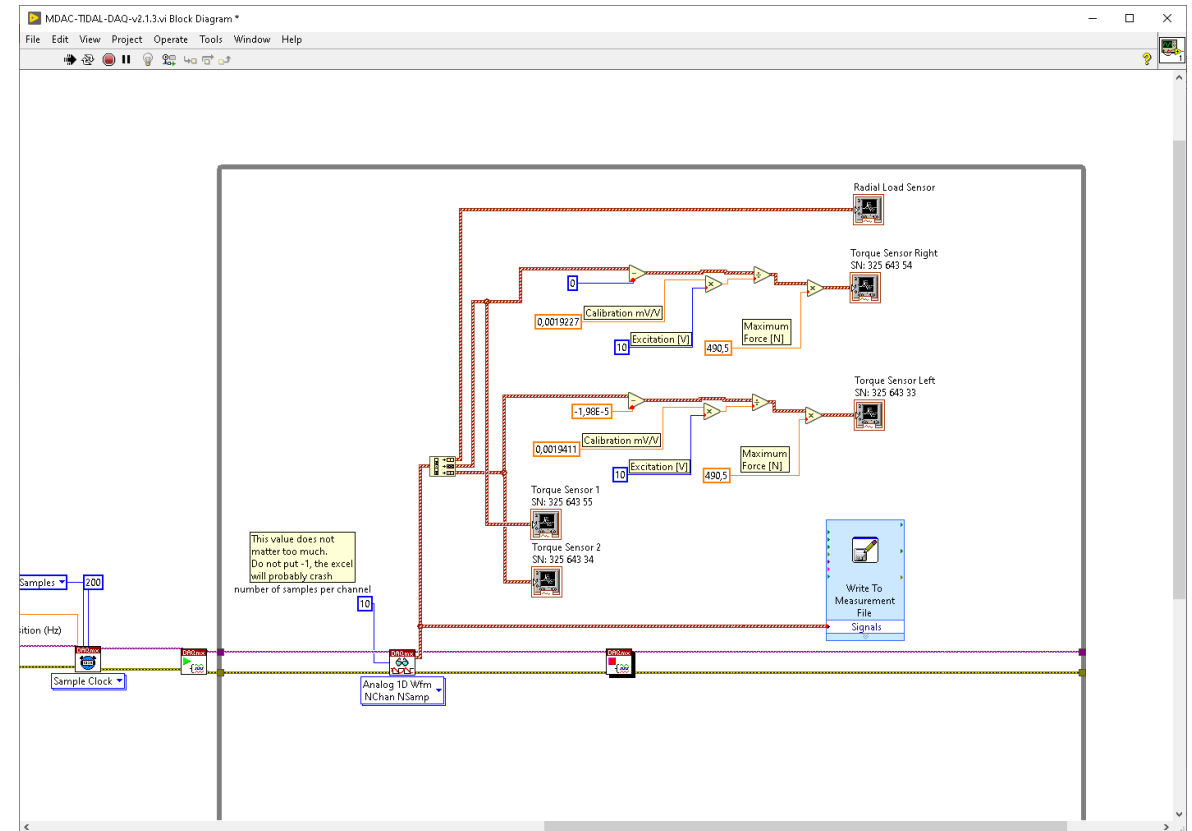
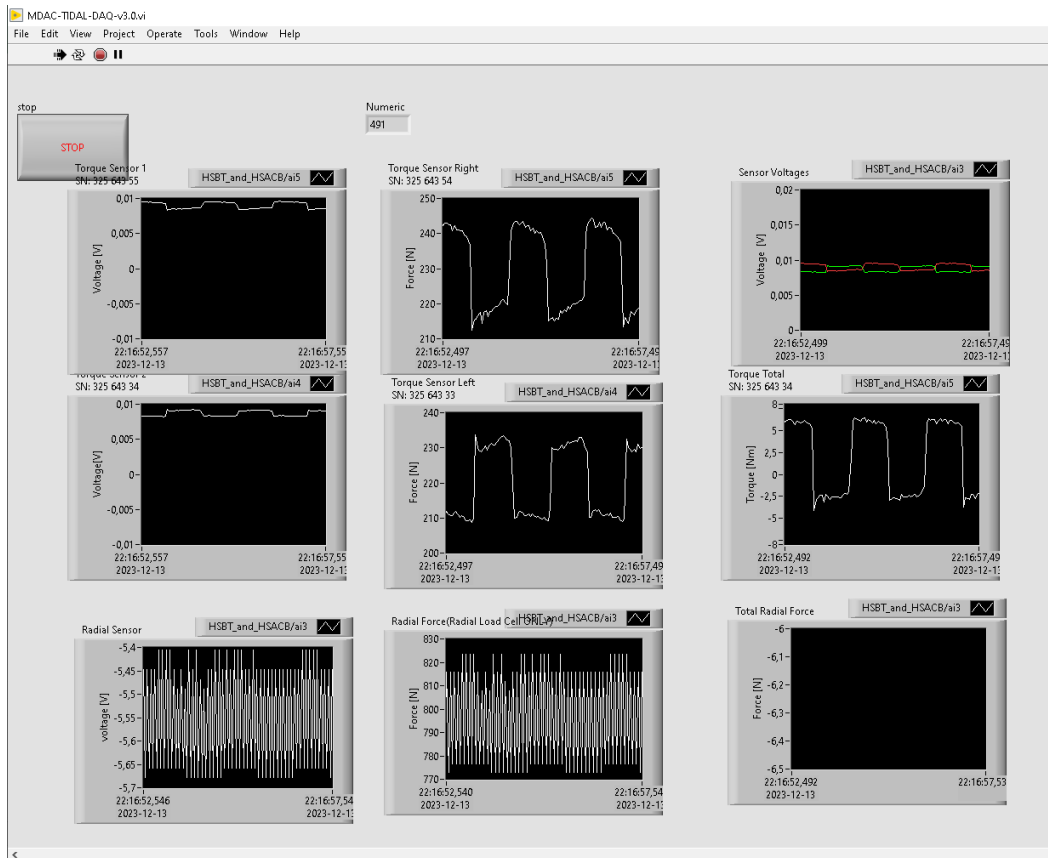

3. Proof of Concept – Friction Load Cells

Load cells and DAQ were verified by applying weights on top of them. The verification was made in compression although they are used in tension after assembled in the test rig.

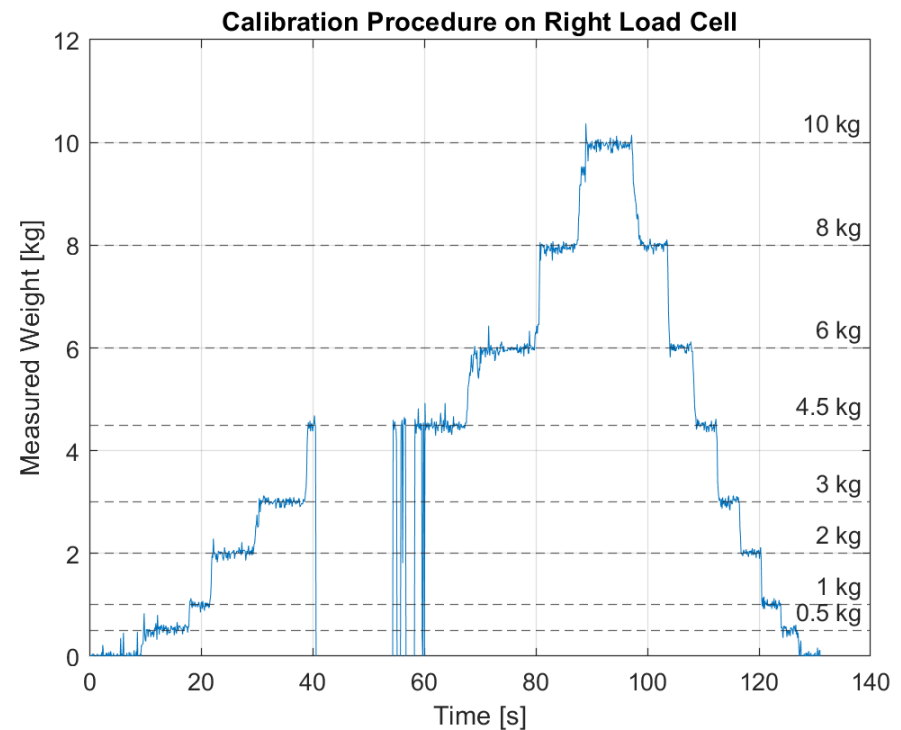
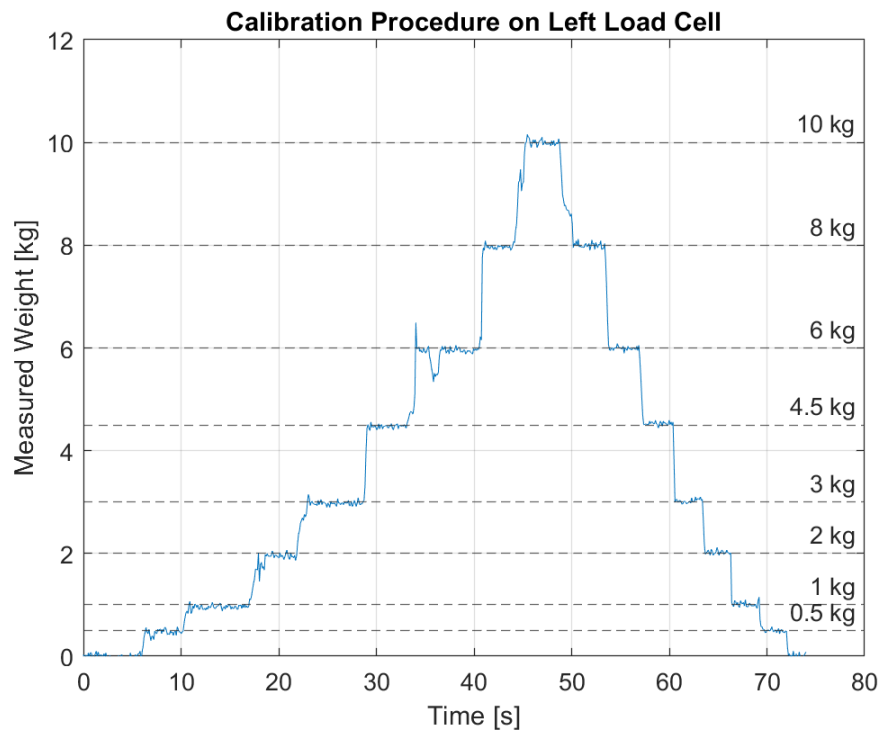

3. Proof of Concept – Radial Load Cell

Similar procedure. The current amplifier and AD module does not let fast variation to be measured as well as good resolution.

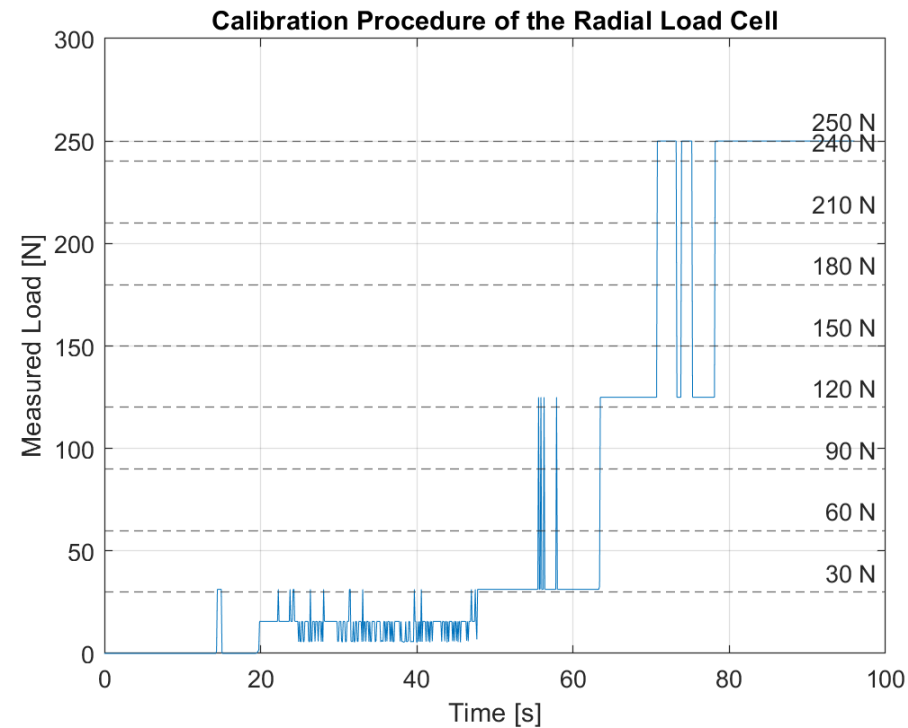

4. Test

Conditions and Procedure

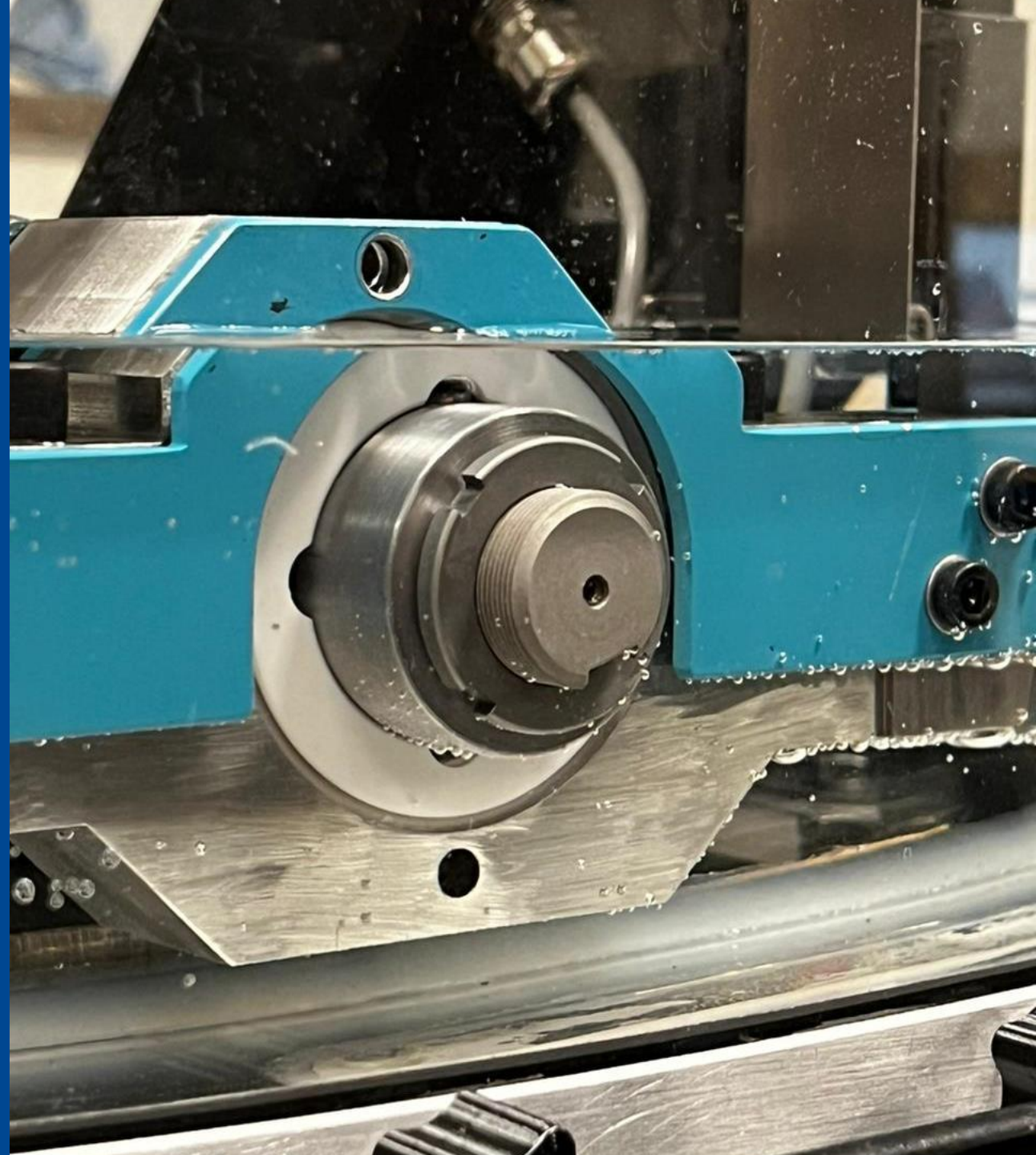

4. Test Conditions

- The test rig specifications:
 - Up to 5kN radial load
 - up to 1200 RPM
- Long term tests will be conducted
- The current configuration is intended for sliding bearings with reciprocating motion
 - Continuous rotation could also be tested on this platform

1. Test rig unloaded without bearing

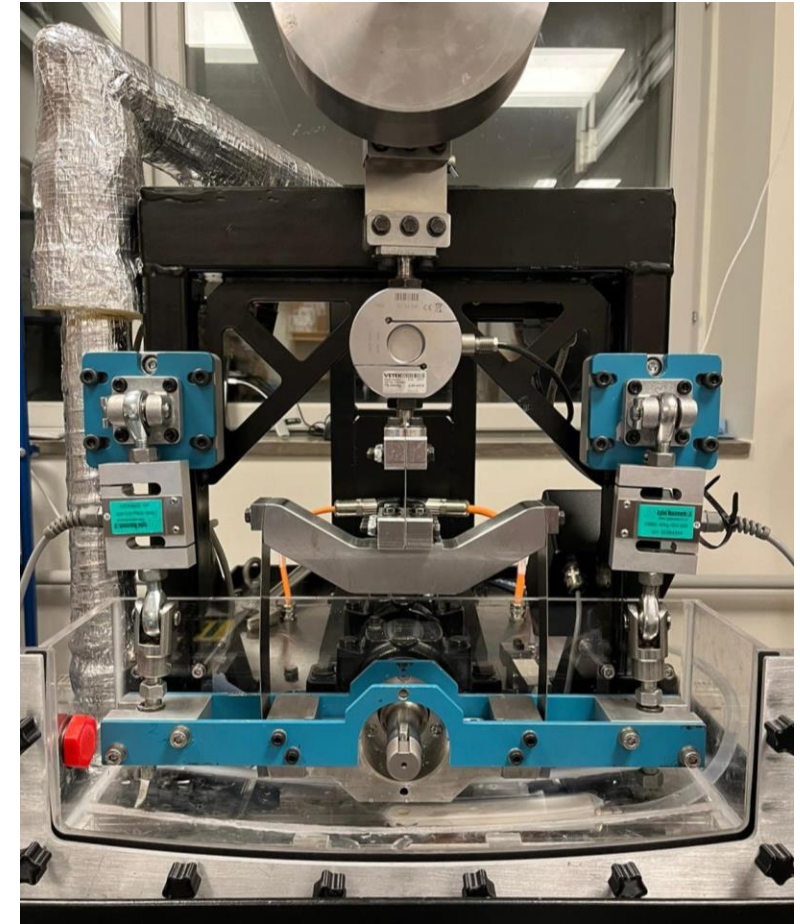

4. Test Procedure

2. Install bearing into the housing

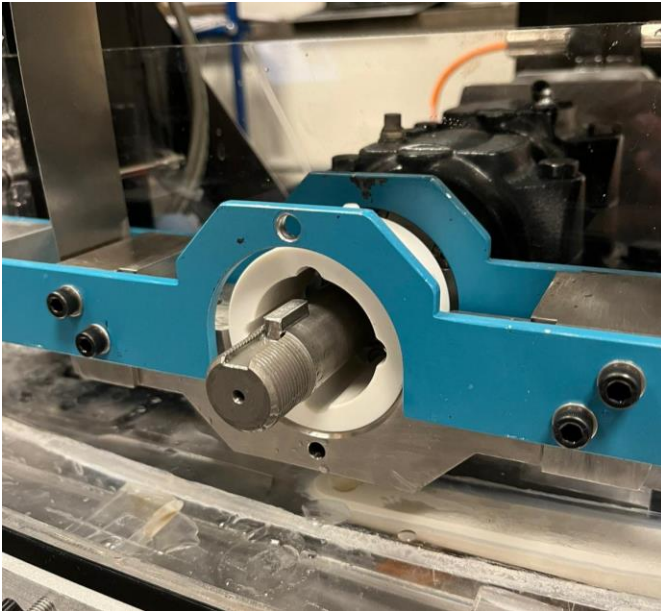

3. Install sleeve and locknut on the shaft

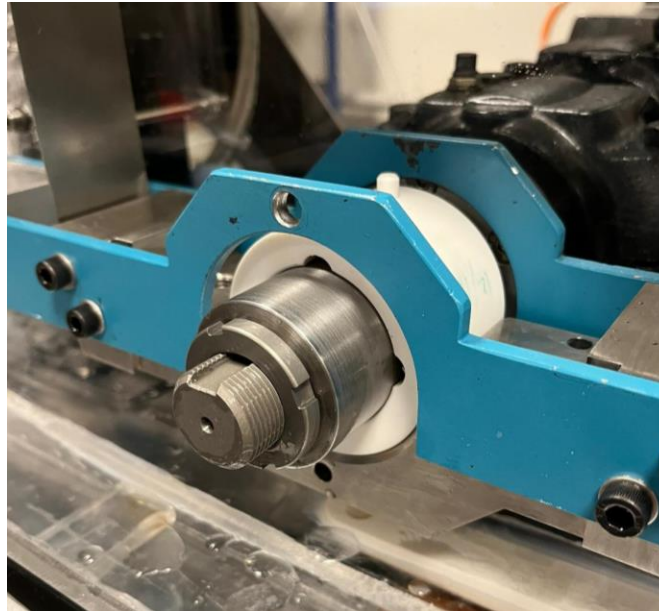

4. Install upper housing part

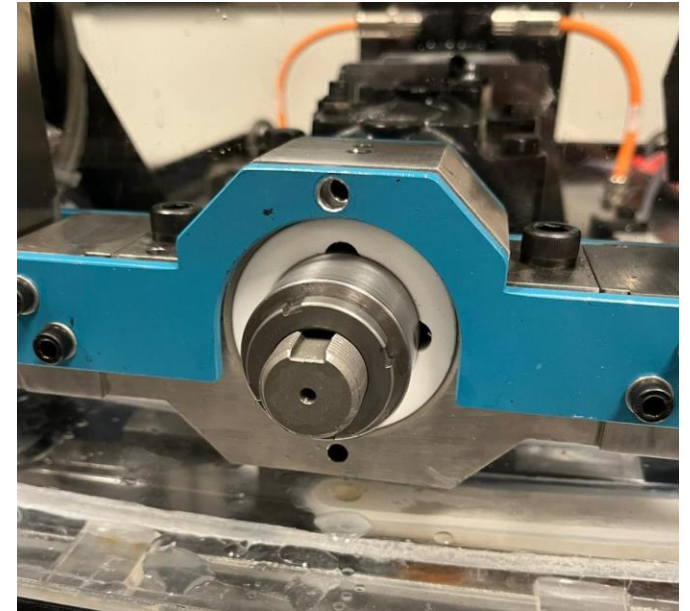

4. Test Procedure

5. Set up a dial gauge on the sleeve

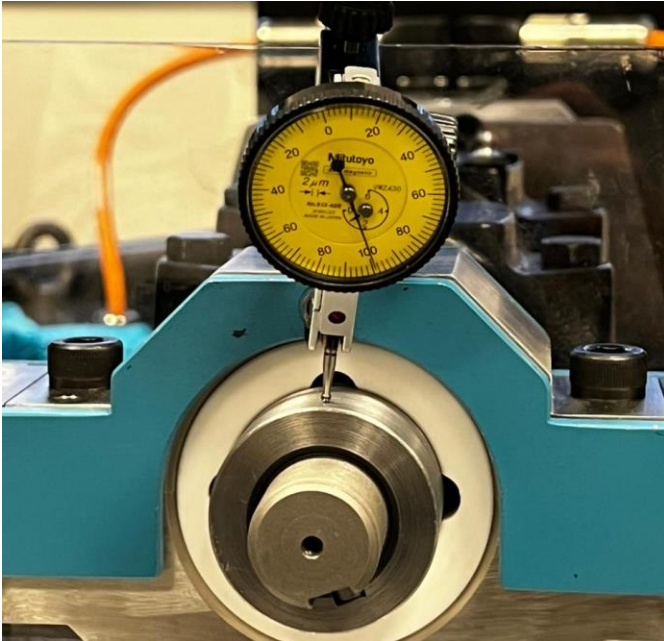

6. Apply the radial load to the desired value

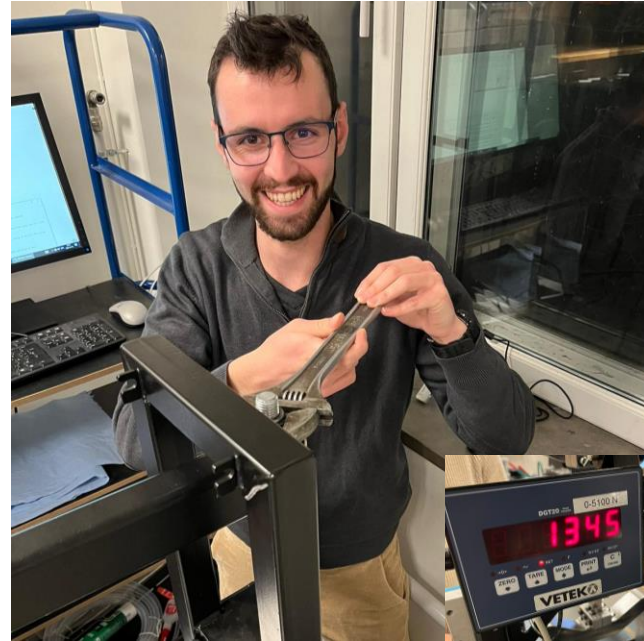

7. Tighten nuts to apply a 250N preload to each load cell

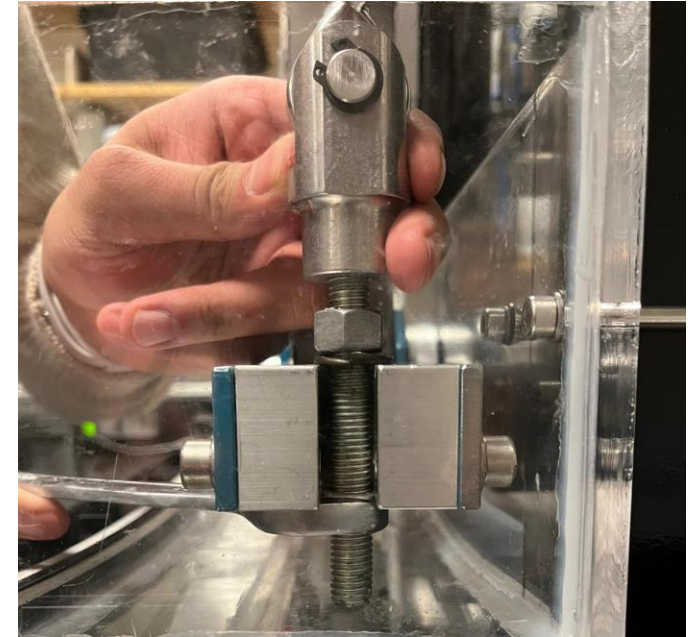

4. Test Procedure

8. Install front panel of tank and add water

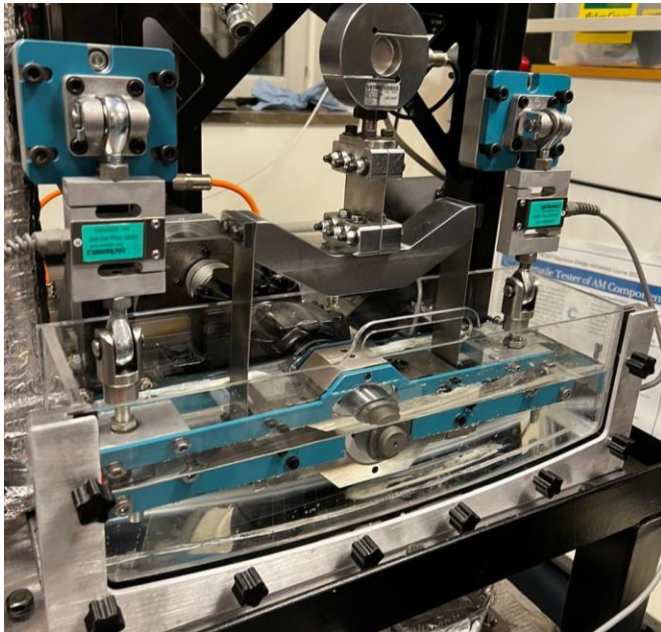

9. Set up test parameters and DAQ system

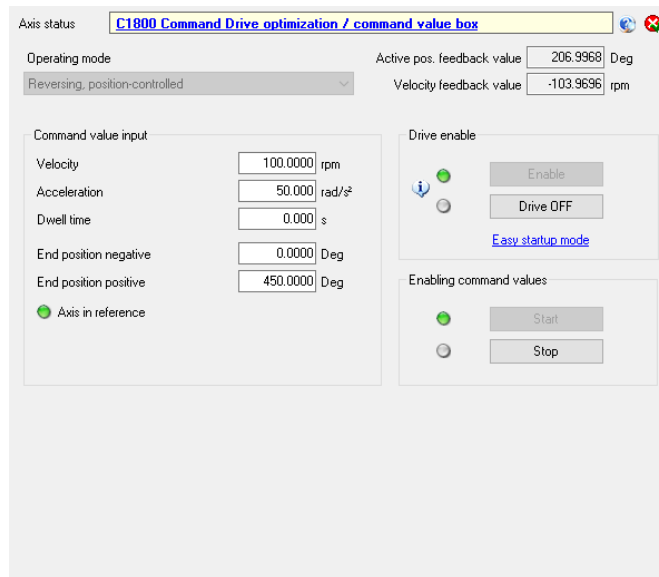

10. Enable motor and begin the test

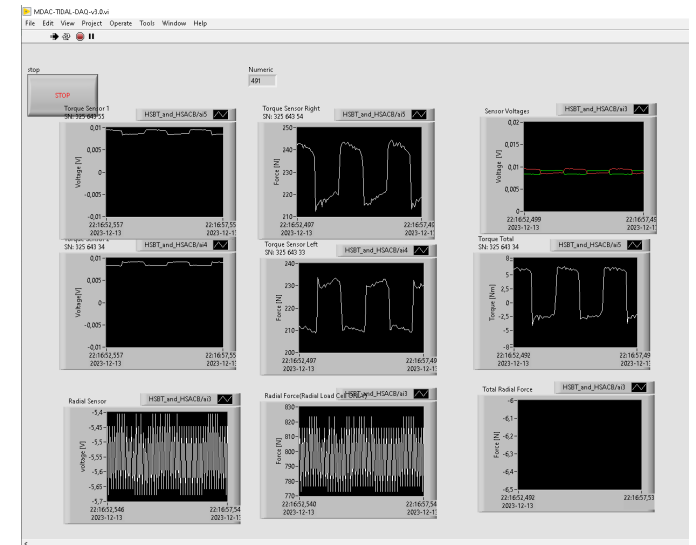

4. Test Preview

- We have conducted several short-term tests on Vesconite bearings.
- Motion is displayed in the gif

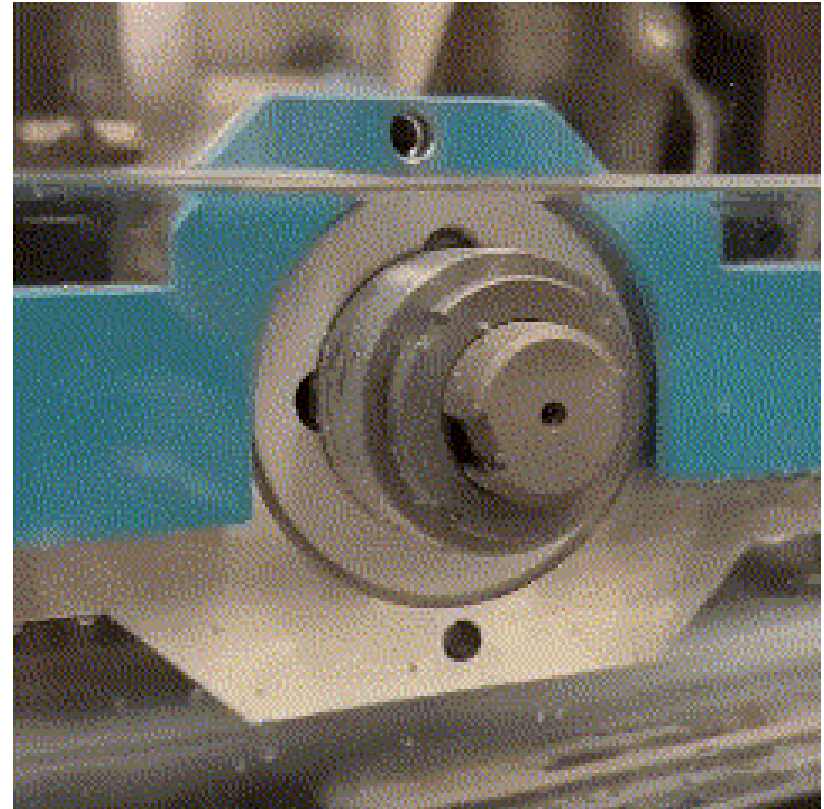

5. Results and future work

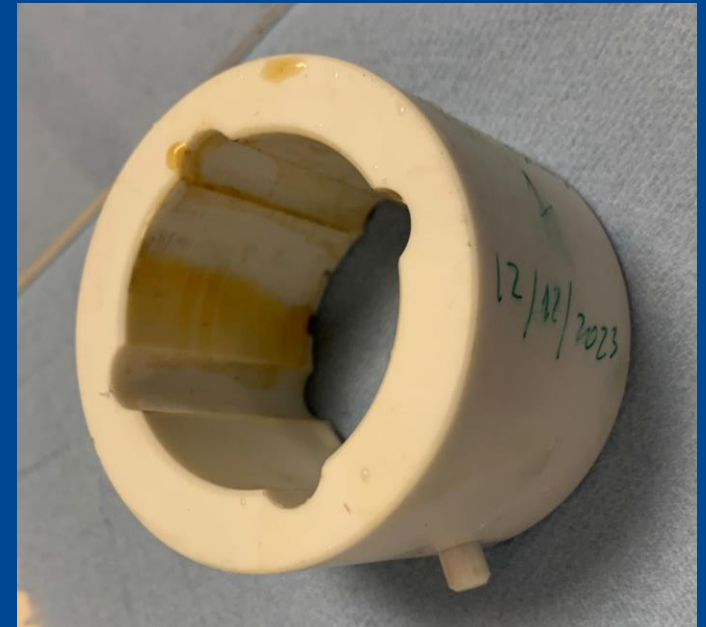

5. Results

- 2 Bearings were tested:
 - **Vesconite High Lube** (Initial Load = 750 N → 0.37 MPa)
 - Vesconite Super Lube (Initial Load = 1500 N → 0.74 MPa)

- Main speed profile
 - 20 rpm (47.1 mm/s)
 - 10 rad/s²
 - 90° of full stroke
 - 0 seconds of dwell time

- Expected Pressure Load
 - Vesconite High Lube → 0.37 MPa
 - Vesconite Super Lube → 0.74 MPa

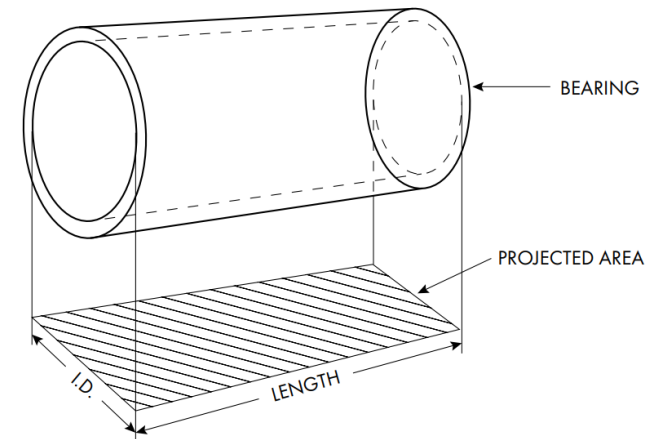
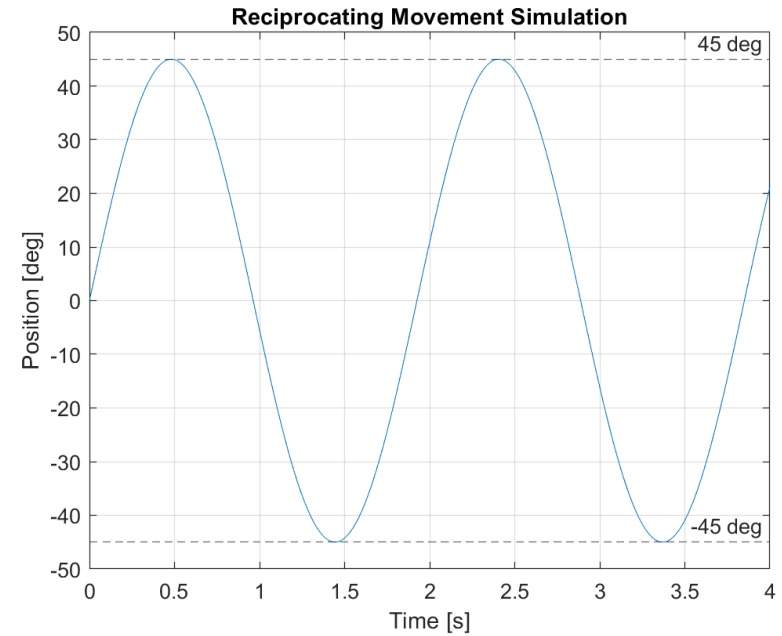
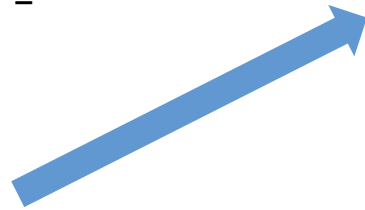

5. Results

Sample of the measured force

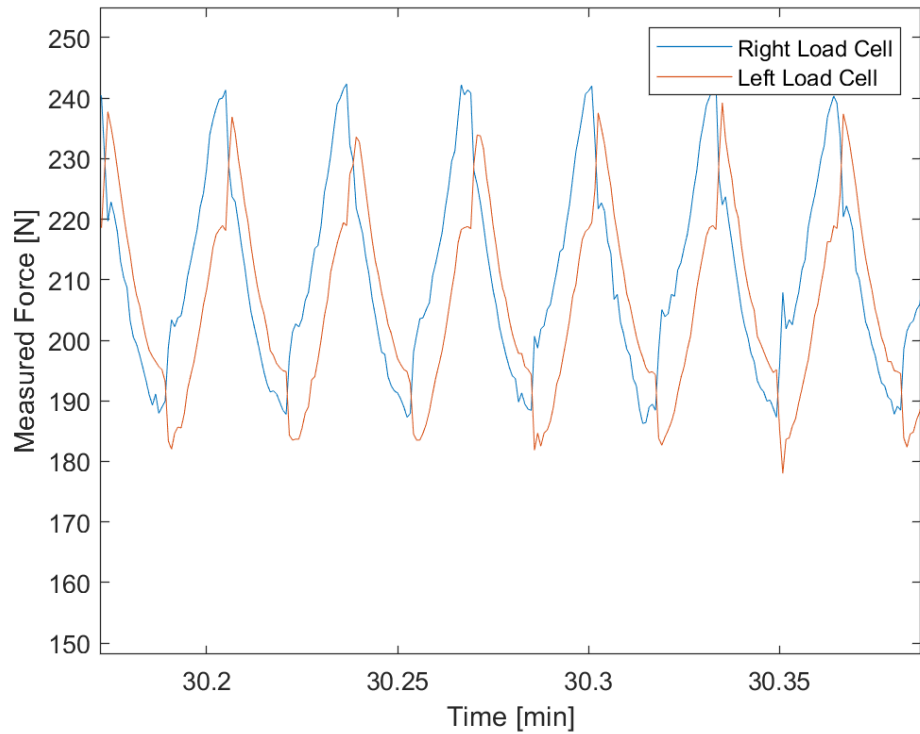

(Problem recently fixed)

Maximum and minimum force

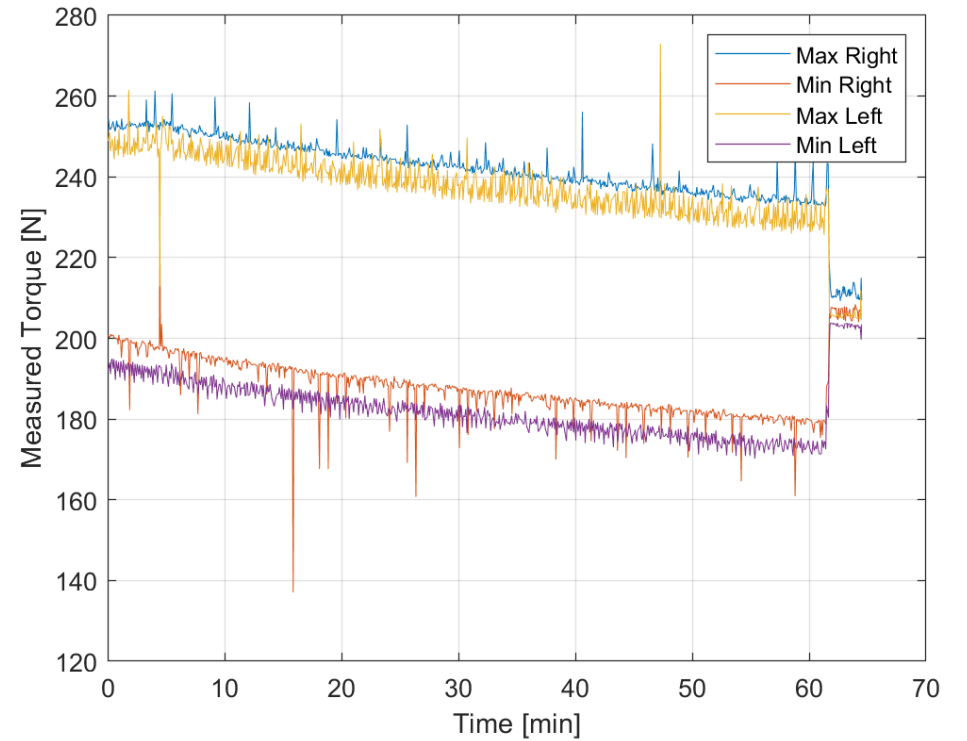

5. Results

Differences between max and min values

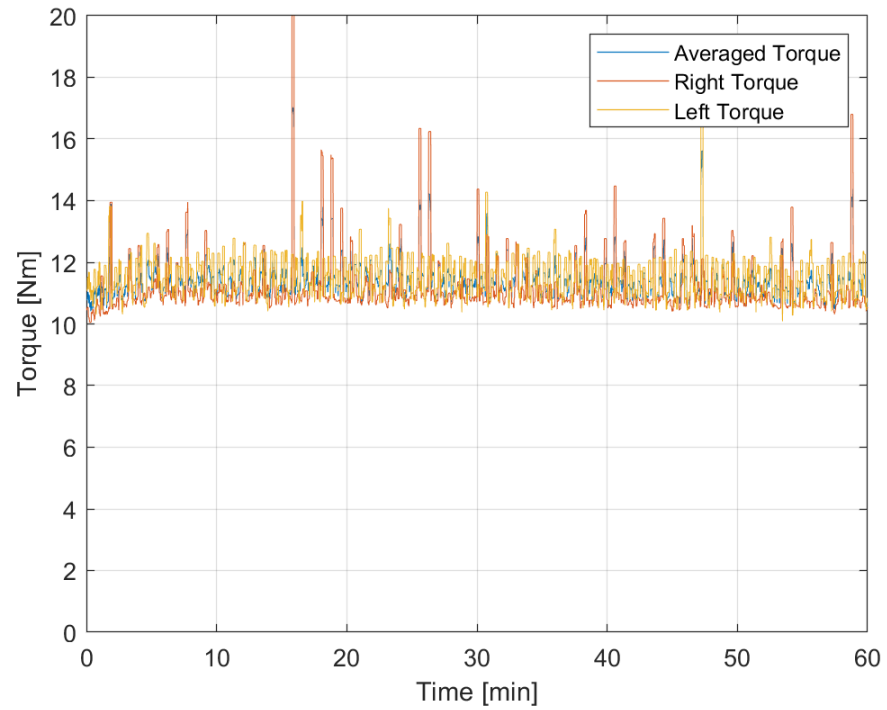

Calculated torque

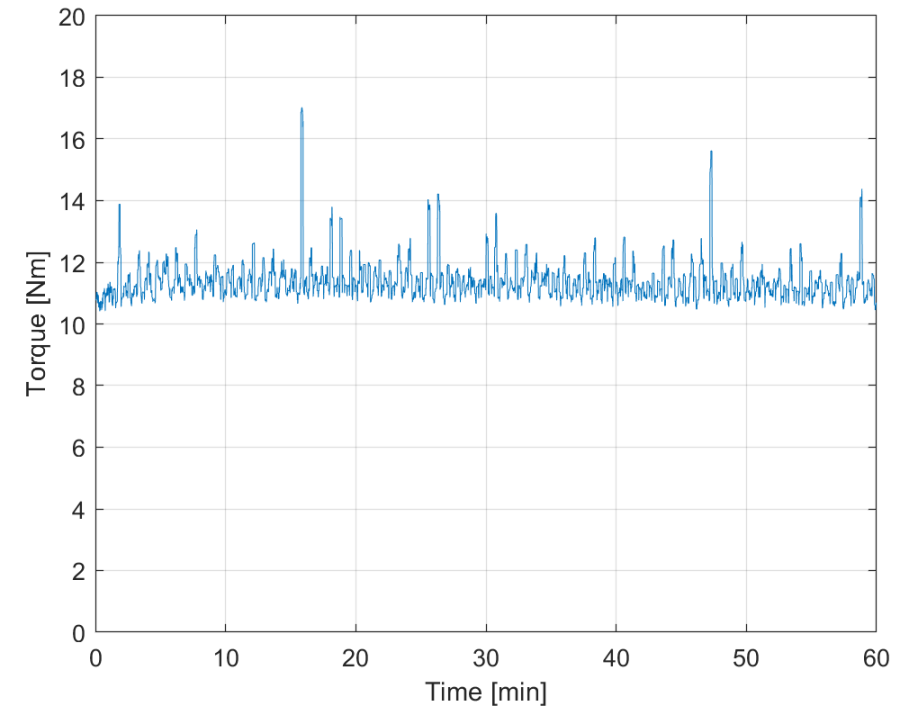

5. Results

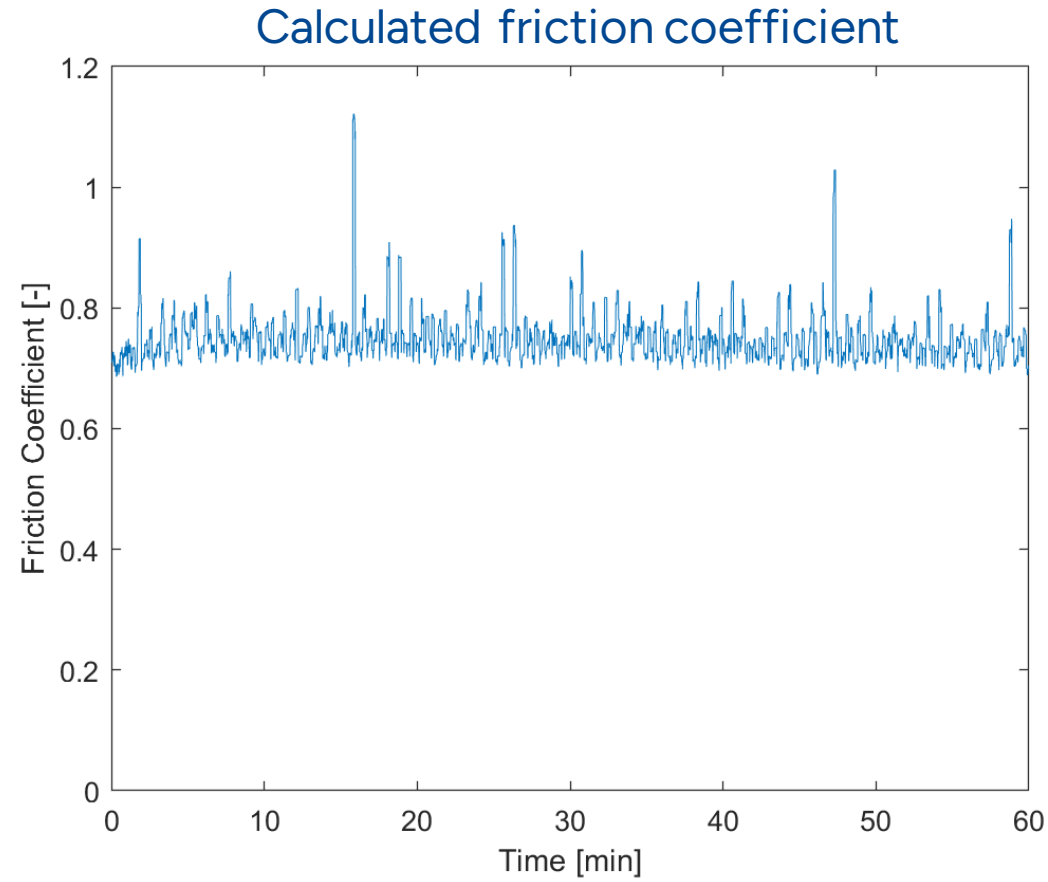

5. Future work

- Manufacture a new shaft with AISI 440.
 ➡ Tempered at 316°C ➡ Hard Chrome Plating
- Manufacture a new Sleeve with AISI 316 (Stainless steel 316) with recommended roughness specifications.
- Determine the stiffness of the vertical sheets to achieve more accurate results of the friction.
- Validate the torque.
- Improve electrical implementation.
- Improve LabView program.
- Bypass amplification system of radial sensor.
- Use the rig for tribological studies.

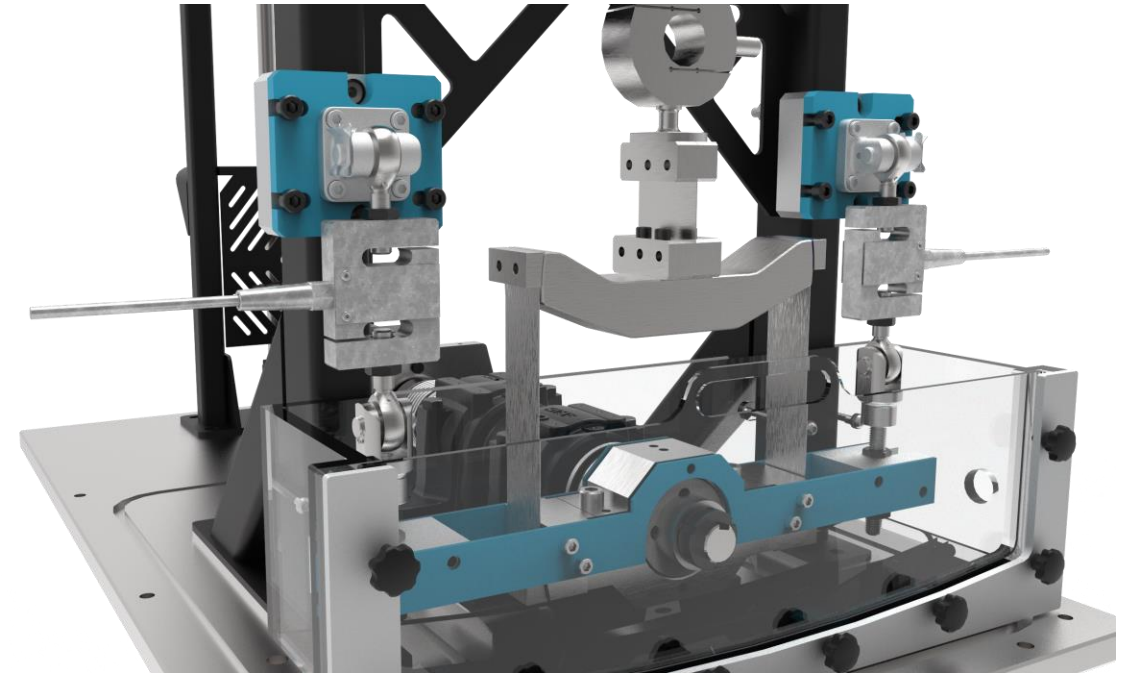



Thank you for your attention

Any questions?

Alexander, Rohit, Ricardo, Numan and Florian