

Co-Designing for Gold Mining Safety

A Major Qualifying Project
submitted to the Faculty of
Worcester Polytechnic Institute
in partial fulfillment of the requirements for the
Degree of Bachelor of Science

Submitted By:

Isabel Azevedo
Madison Cunniff
Van Harting
Rosa Reynoso
Rediet M. Tegegne

Date:

2 March 2020

Submitted to:

Dr. Robert Krueger, Worcester Polytechnic Institute
Dr. Pratap M. Rao, Worcester Polytechnic Institute
Okyeman Environment Foundation, Sponsor

Abstract

The use of mercury in artisanal and small scale gold mining in Ghana poses serious environmental and health risks. The purpose of this project is twofold; to improve safety by prototyping a device to reduce mercury exposure, and to document our novel co-design approach. We formed partnerships with miners, community members, and tradespeople in the town of Osino, Ghana through participant observation and collaborative design workshops. We prototyped three iterations of retorts, blending our technical expertise with miners' local expertise. By allowing miners to lead the stages of design and grounding our partnership in mutual respect and sharing of ideas, our partners recognized their own capacity to shape their own outcomes. Future efforts can include further technical and field testing to improve device function and manufacturability and an implementation scheme to expand access to these devices.

Acknowledgements

We would like to express our gratitude for those who provided the team with constant support and assistance throughout the duration of this project. The success of this project would not have been possible without the dedicated efforts of the many individuals who showed genuine passion and devotion in the realization of our project.

We would first like to give sincere thanks to our sponsor, Kofi Gyimah of the Okeyman Environmental Foundation, who provided our team with valuable contacts. His expertise and support, in spite of his busy schedule, allowed us to develop cross cultural relationships with the people of Ghana. The partnership of the Okeyman Environment Foundation and Worcester Polytechnic Institute has laid the foundation for a successful implementation and continuation of this project.

Our advisor, Dr. Robert Krueger and Dr. Pratap Rao provided us with insight, support and guidance which helped with the completion of this project. Our advisors provided us with valuable input and patience throughout the development of our project and report.

Lastly and most importantly we would like to thank the miners in Osino for designing this device alongside us. We can truly see their dedication and commitment towards making their community safer. We have learned so much through our time in Osino and have an immense appreciation for their kindness, hospitality, and hard work in helping our project come to fruition.

Table of Contents

Abstract	1
Acknowledgements	2
Table of Figures	5
Table of Tables	5
Executive Summary	6
Chapter 1: Introduction	7
Chapter 2: Literature Review	8
History of Mining Industry In Ghana	8
Mercury in The Mining Process	11
Potential Technical Solutions	15
Cross Cultural Design	20
Chapter 3: Methodology	22
Cross-Cultural Design And Co-design	22
Timeline	22
Social Data Collection	23
Technical Data Collection	25
Leak Test	25
Prototype Questionnaire	26
Static Analysis	26
Operations Safety And Maintenance Manual	26
Findings	26
Prototype 1	27
Prototype 2 And Prototype 2.5	32
Final Iteration - Prototype 3	39
Recommendations	43
Conclusions	45
References	47
Appendices	50
Appendix A: Agendas For Inactive And Active Mine Visits	50
Appendix B: Agendas For Workshops	50
Appendix C: Device Questionnaires For Miners	50
Appendix D: Operations Safety & Maintenance Manual	50

Table of Figures

FIGURE 1: SMALL SCALE MINING PROCESS	11
FIGURE 2: SMALL SCALE GOLD REFINING PROCESS	12
FIGURE 3: LANTERN RETORT (AMANKWAH AND OFORI-SARPONG, 2010)	17
FIGURE 4: CO-EVOLUTIONARY DESIGN PROCESS FOR DEVELOPMENT	21
FIGURE 5: STUDY TIMELINE IN GHANA	23
FIGURE 6: PHOTO OF OSINO MINER'S DESIGN	30
FIGURE 7: PHOTO OF PROTOTYPE 1	31
FIGURE 8: TECHNICAL DRAWING OF PROTOTYPE 1	32
FIGURE 9: DEVELOPED CLOSED SYSTEM DESIGN	33
FIGURE 10: COILED PIPE CONDENSATION SYSTEM DESIGN	34
FIGURE 11: COILED PIPE CONDENSATION SYSTEM DESIGN WITH FAN	35
FIGURE 12: PHOTO OF PROTOTYPE 2	36
FIGURE 13: TECHNICAL DRAWING OF PROTOTYPE 2 SIDE VIEW	37
FIGURE 14: TECHNICAL DRAWING OF PROTOTYPE 2 TOP VIEW	37
FIGURE 15: LEAK TEST OF PROTOTYPE 2	38
FIGURE 16: MODIFIED BURNING VESSEL	38
FIGURE 17: PHOTO OF PROTOTYPE 2.5	39
FIGURE 18: FINAL DEVICE TECHNICAL DRAWING	41

Table of Tables

TABLE 1: MERCURY PATHWAY OF EXPOSURE SUMMARY (WORLD HEALTH ORGANIZATION, 2016)	14
TABLE 2: CO-DESIGN CRITERIA DEVELOPED AFTER FIRST WORKSHOP WITH THE MINERS	28

Executive Summary

Over the past semester, we have developed the understanding needed to address safety concerns faced by artisanal and small scale miners in Ghana. The research we completed has been compiled into the following paper, which includes an introduction to the project, a literature review, our co-design process, and the development of a technical solution. The literature review includes an overview of the history of colonialism and modernization in the country, as well as how the mining industry has developed to its present situation. Additionally, the section outlines how mercury is used in artisanal and small scale mining processes to facilitate the amalgamation of gold. Moreover, it describes the environmental and health hazards associated with mercury. This allowed us to identify the vaporization of mercury and the inhalation pathway associated with it as our principal area of focus.

The next section outlines various technical solutions that we have considered in the early stages of our research process. We explored a range of solutions, including protective mining devices such as gloveboxes and retorts, as well as alternatives to mercury such as the use of cyanide or borax. Ultimately, a retort was the most fitting technical solution, as it protects the miners from mercury vapor inhalation while potentially reclaiming the mercury for future use.

Our methodology delves into the co-design process for our mining device. We outlined our timeline for the project once we arrived in Ghana. An important aspect of this chapter is the integration of co-design into our methods as well as the development of rapport with our local partners. We aimed to use participant observation, informal interviews, and workshops with miners to form partnerships that produce appropriate and effective solutions. Additionally, it outlines the qualitative and quantitative data collected throughout our co-design process. All of this information was critical to facilitate our iterative co-design process.

Our findings chapter outlines the prototypes we co-designed. This section outlines the results of our social and technical data collection and how this information was used to fabricate our prototypes. Ultimately, this section details our third and final prototype. Lastly, our recommendations and conclusion section outlines what future steps need to be taken to solidify the implementation of our project. It outlines also the testing that still needs to be completed to ensure the validity of our design.

CHAPTER 1: INTRODUCTION

Artisanal and small-scale mining (ASM) is a prevalent practice throughout Ghana that requires the use of mercury, which presents both health and environmental hazards. However, ASM creates economic opportunity necessary to support the livelihoods of thousands of people. Our project aimed to design a device to limit the direct exposure of mercury to miners, and in turn mitigate the exposure to their families and the environment as well.

ASM practices have resulted in devastating environmental effects and a lower quality of life for miners and locals in Ghana. Before our arrival to Ghana, the team researched the history of ASM, specifically the political, social, and cultural factors that have influenced local miners to adopt these practices. We aimed to gain an understanding of the current ASM process in Ghana, specifically its effect on human health and the environment. Furthermore, we studied similar cases around the world and identified potential solutions to the issues at hand.

On site in Ghana, we collaborated with local experts and community members to design suitable prototypes. We adopted an iterative co-evolutionary design process that involved the cooperation of local expertise and the use of locally found resources. Ensuring that the locals take ownership of this program was extremely important, as their involvement allowed community members to understand the content, purpose, and value of the prototype, thus leading to greater motivation to use and maintain it.

CHAPTER 2: LITERATURE REVIEW

HISTORY OF MINING INDUSTRY IN GHANA

Ghana has a long history of resource extraction, as the country is endowed with substantial mineral resources in commercial quantities. Mining governance has been impacted by changes in the dominant actors, regulations, and national and international influences from the pre-colonial period to the present day.

As Bebbington (2019) explains, the dominating leaders of the mining industry in the pre-colonial period were the chiefs and kings. They acted as trustees for the land, and required that one-third of the miners' proceeds be given to each party in addition to enforcing a tax on gold sales (Bebbington, 2018). Mining was therefore not considered to be a profitable business as much of the gold revenues failed to reach a larger part of the population, and were instead reserved for elites (Bebbington, 2018). Despite this, Ghana accounted for 36% of the total world gold output between 1493 and 1600 (Tsikata, 1997).

When Ghana was colonized by the British in 1865, their mineral wealth was heavily exploited by Europeans. As the British gained control over the area, they looted gold wealth and asked for reparations from victors in the form of gold payment as well (Kevane, 2015). To further exploit these mineral resources, the British aimed to gain control of mineral rich lands, and encouraged European buyers to apply for land concessions. Land concessions gave capitalist foreign companies the right to control specified areas of land, degrading the authority of the chiefs. These changes in the control of land made European mining companies the main beneficiaries of gold mining, in turn giving them significant influence on the implementation of mineral policies. (Bebbington, 2018). An example of the development of mineral policies used by the British to further extend their power over commercialized lands was the implementation of the Mercury Ordinance Law of 1933. This law banned the use of mercury in mining activities, which impaired artisanal and small scale mining activity by criminalizing their only means of purifying gold (Bebbington, 2018).

When Ghana gained independence from the British in 1957, active state involvement in the mining industry continued, as opposed to returning land management responsibilities back to local chiefs. The passage of the Minerals Act and Administration of Lands Act (1962) mandated that payments in respect to mineral rich lands be made to the sector minister and not to the chief

of the community. State-owned mining quickly deteriorated Ghana's economy due to the lack of public and private investments that left the mining industry uncompetitive (Bebbington, 2018).

Between 1986 and 2008, many policies were implemented with the hopes of reviving the mining sector. In fact, the mining industry received priority attention in 1983 under the Economic Recovery Programme (ERP), which created various reforms to boost interest in the sector (Amponsah-Tawiah et al., 2011). The Minerals and Mining Law (PNDC Law 153 of 1986) established the Minerals Commission to regulate the sector on a national scale by liberalizing mining and extending benefits to private investors. For example, companies received breaks on import taxes and the costs of mining equipment (Amponsah-Tawiah et al., 2011). This did not have a significant impact on the health, wellness, or economic growth in mining-affected communities, especially those that had been previously outlawed during British rule (Bebbington, 2018). The artisanal and small scale mining industry was later brought back into the official economy with the establishment of the Small-Scale Gold Mining Law, the Mercury Law, and the Precious Minerals Marketing Corporation Law which legalized and regulated the previously illegal mining sector. Ghanaian artisanal miners could apply for a concession, obtain a license to mine legally, and purchase mercury from authorized sellers for purposes of gold production (Bebbington, 2018). Although these policies positively impacted the economic growth of mining-affected communities that had been previously ignored, uneven power relations between dominant mining companies and small scale miners still remained. This allowed for the development of an informal system between chiefs and illegal small-scale operators, as they were forced to turn to chiefs to obtain land for their operations. (Bebbington, 2018).

In 2008, an increase in gold prices set the stage for a gold rush that introduced other foreign miners into Ghana's ASM industry. Miners from China brought advanced mining technology and Chinese loans that were used to invest in activity, making informal partnerships with these Chinese investors very appealing to Ghanaian small-scale miners (Botchwey, 2019). These partnerships were illegal according to Ghanaian law, and over time the involvement of the Chinese in informal mining resulted in outbreaks of violence. The government was finally forced to combat illegal small scale mining, and focused heavily on arresting and deporting Chinese foreign nationals (Botchwey, 2019).

China's informal gold rush presented many unintended consequences. One consequence was the establishment of inequalities among Ghanaians involved in ASM. Because the Chinese

brought more advanced technology and investments, those without access to these technologies, such as Ghanaian women, children, and young people, were left to extract the remaining scraps. Environmental damage to land and water resources was also exacerbated by the presence of foreign miners. Streams and rivers were diverted for mining purposes, and surface and groundwater was polluted with hazardous chemicals needed for gold processing, such as cyanide and mercury (Botchwey, 2019).

Despite the permeating environmental impacts of ASM, it is often seen as the only option by many Ghanaians to support their livelihoods. There are often disputes over whether money being produced by commercial mining practices is properly used to reduce the poverty levels from which this mineral wealth stemmed from. Economic growth in large scale mining operations often does not trickle down to workers due to bad governance and corruption, which makes ASM a more appealing option (Geenen, 2016). Because of the independence and financial stability that ASM provides, miners often either overlook or are unaware of the health and environmental effects of the process (McQuilken, 2016).

Today, artisanal and small scale miners typically begin their process in an area that a commercial mining company has already exploited, as deforestation and digging has already been completed. The ASM process is outlined in Figure 1 based on ASM practices in Osino, Ghana. Miners typically use a Chinese device, called a changfa [1], which is a diesel-run motor that powers a crusher using a fan-belt system [2]. Miners shovel ore into the crusher [3] for a continuous 8 hour day. Water is also continuously pumped from a nearby river using hoses [4] to prevent overheating of the changfa and improve the efficiency of the grinder.

The running water is also an integral part of the separation of undesired rock from valuable gold pieces. After exiting the grinder, the slurry pours into a wooden box [5] underneath the changfa system. The box has a weir to slow the flow of the mixture before entering two wooden chutes, approximately 6 feet long. Two carpets [6], one with longer plastic fibers and one with shorter fibers, are respectively laid along the bottom of each chute. Gold, a heavy metal, is more easily caught in the fibers of the carpet as opposed to other rock fragments which remain suspended in the running water. These carpets are rinsed each hour into one plastic bucket [7] that collects all of the gold particulates. At the end of the workday, the water from this bucket is partially drained, leaving the finely ground ore and water slurry that must be processed with mercury.

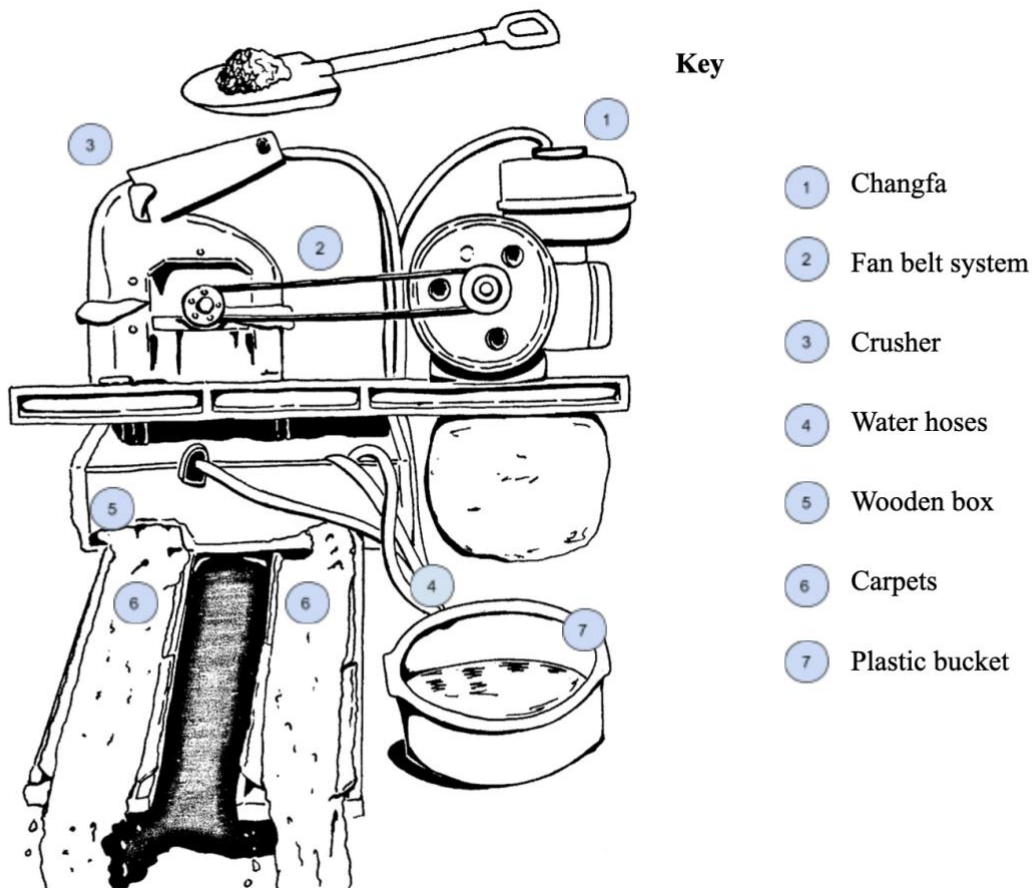

Figure 1: Small Scale Mining Process

MERCURY IN THE MINING PROCESS

After each 8 hour day of mining, the miners have collected enough ore to begin the gold refining process, outlined in Figure 2. First, mercury is added into the same plastic bucket that the carpets are rinsed in. The added mercury attaches to the gold creating the amalgam, leaving behind other heavy metals and rock sediment [1]. The miner then removes the amalgam from the plastic bucket, and rubs it between the palms to encourage the formation of a uniform ball of mercury-gold amalgam [2]. The amalgam is then placed into a handkerchief to squeeze any remaining mercury from the mixture, which is ultimately saved for future use [3]. Occasionally, miners put the handkerchief in their mouth to suck out excess mercury. Once all excess mercury has been squeezed out, the vaporization process begins. The mercury vaporization process is typically performed in a separate location from the mining site for security reasons, typically close to the miners home. The amalgam is transferred to a metal can or bowl, and heat is applied with a blow

torch [4]. The miner watches the amalgam burn for visual cues that the mercury has been completely vaporized. This includes watching for the white-colored vapor to disperse, and for the amalgam to shift from silver to gold in color. Once these occur, the burning process is complete and a semi-pure gold product remains for sale.

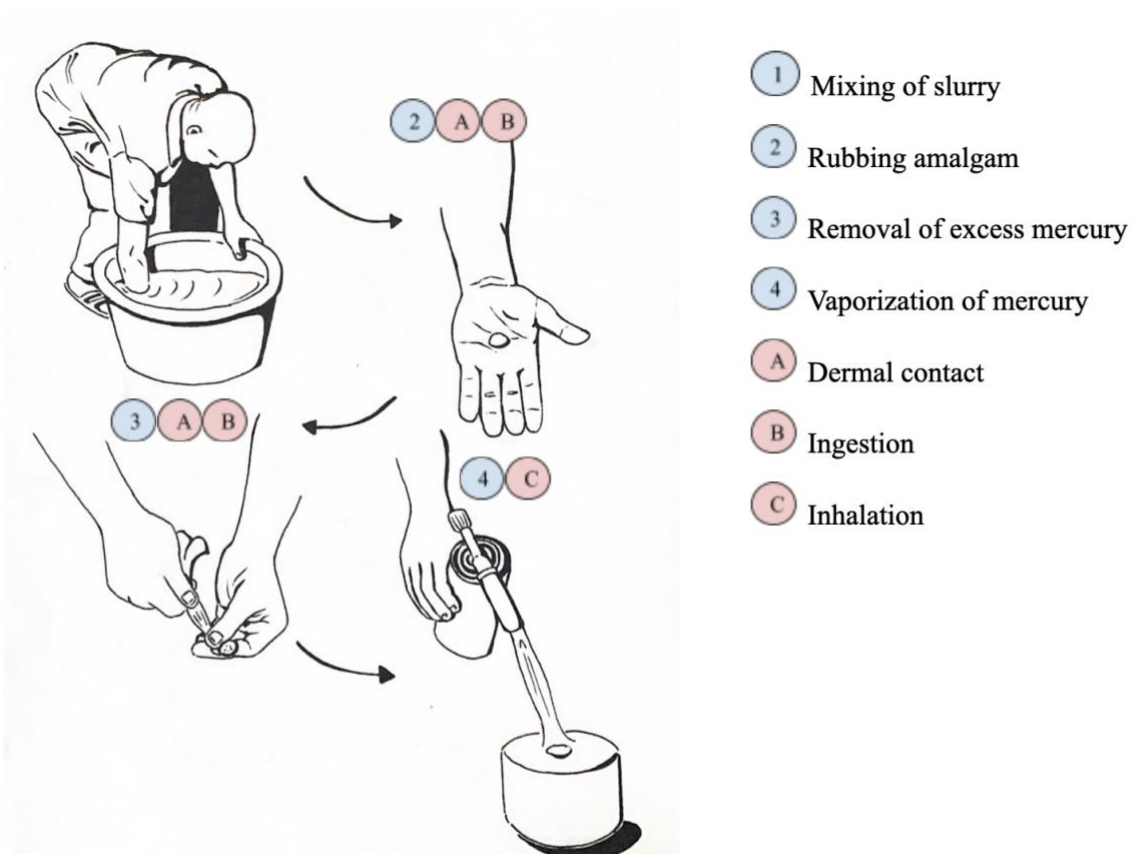

Figure 2: Small Scale Gold Refining Process

Each step of the ASM gold refinement process results in at least one pathway of mercury exposure to the miner, outlined in Figure 2. When the miner mixes the slurry to form the amalgam, further rubs the amalgam, and removes excess mercury, the miner experiences dermal contact [A] that can lead to accidental ingestion [B]. Additionally, family members can experience the effects

of mercury through contact made with the miner. Infants are especially susceptible as their central nervous systems are undergoing development (United Nations Development Program, 2018). When the mercury is vaporized, the miner is exposed to inhalation of the mercury [C]. Each pathway of exposure correlates to general symptoms that a miner may experience, outlined in Table 1.

Following a single incidence of exposure, mercury is a health hazard for reproductive health and specific organ toxicity (United Nations Development Program, 2018). The threshold for poisoning is considered to be “continuous exposure to elemental mercury in the atmosphere at a minimum level of 20 micrograms per meter cubed of air for several years” (World Health Organization, 2016). Fifty mine workers from Anhwiaso near the Ankobra River Basin in Ghana were tested for mercury levels in their blood and urine. The mean values were 102.0 ug/L and 34.5 ug/L, respectively. The blood mercury concentration limit for a non-exposed person is 3 ug/L, which every sample exceeded, posing serious health risks (United Nations Environmental Programme, 2019). While the effects of mercury are recognized worldwide, there have been no comprehensive studies on the extent of its health impact in Ghana (Tschakert, 2007).

Table 1: Mercury Pathway of Exposure Summary(World Health Organization, 2016)

Pathway of Exposure	Method of Exposure	General Symptoms of Exposure
Dermal Contact - A	- Rubbing of mercury and sandy silt together to create amalgam	- Contact dermatitis - Skin irritation
Ingestion - B	- Water or food contamination - Methylmercury bioaccumulation in fish - Sucking excess mercury from amalgam	- Changes in mood - Memory loss - Numbness - Hearing and speech difficulties - Muscle weakness - Vision changes - Tremors
Inhalation - C	- Vaporization of amalgam to beneficiate gold	- Chemical pneumonitis - Dry coughing, chest pain, difficulty breathing or shortness of breath - Hypertension - Kidney and respiratory damage leading to failure - Death

In addition to causing serious health concerns for humans that are exposed, mercury can lead to disastrous effects in the environment in high concentrations. As of 2015, 49% of global mercury emissions occur in Asia, followed by 18% in South America, and 16% in Sub-Saharan Africa (United Nations Environmental Programme, 2018). In Ghana, 56% out of the estimated 81,060 kg of mercury released into the environment per year is from ASM, with 53% entering the atmosphere, 30% entering the land, and 10% entering water bodies (United Nations Development Program, 2018). Mercury naturally exists in the air in its elemental form. ASM introduces excess mercury into the atmosphere due to the vaporization step in the mining process. The atmosphere

is the biggest transport pathway of mercury emissions, and elemental mercury can travel long distances as the particles can remain in the atmosphere for up to a year (Driscoll, 2013).

Once mercury is introduced into aquatic and terrestrial environments, methylmercury is formed when organic matter and chemical compounds containing sulfides bond with elemental mercury to form mercury sulfide nanoparticles. These particles are smaller in size because the binding of the organic material to the elemental mercury inhibits it from accumulating with other mercury atoms, and the small size of these particles also makes them more soluble. This solubility allows for microbial methylation to occur, during which the elemental mercury is converted into methylmercury (“How Mercury Becomes Toxic in the Environment,” 2009). Methylmercury becomes condensed through the ecological food chain and can eventually be ingested by humans as a result (Hong, 2012). Therefore, mercury can be ingested not only by those within the artisanal mining communities, but also those who have no association with the occupation yet consume fish and shellfish contaminated with methylmercury. Continued water contamination and pollution poses a huge risk in Ghana. According to The Ghana Water Company, between 2008 and 2018 there was a 50% loss of water to pollution. If ASM is left unregulated, they estimate that Ghana may be importing all of the water it needs within the next 10 years (Botchwey, 2019).

POTENTIAL TECHNICAL SOLUTIONS

While design can be simply thought of as conceiving and executing an idea, in practice it is much more complex. In Western engineering education, design is typically taught as a linear progression, moving from problem definition through ideation, evaluation, and experimentation, to fabrication and field testing. This model of design occurs under ideal conditions, with no consideration to its operational setting or users (Murcott, 2007). However, this description fails to capture two elements critical to the success of any design; the people that will use it, and the larger social and cultural context in which it resides.

This lack of regard for context can hinder a design, especially in developmental applications. Engineer Laura Bridgette Parsons argues that, traditionally, foreign engineers completing development projects have “[played] a role of ‘all-knowing’ authority... having very little contact with local communities,” and that “development done *to* or *for* people does not have sustaining or positive effects.” (Parsons, 1996). Therefore, potential solutions must also take into

account the various stakeholders within a community. Potential solutions for ASM related issues must be aimed at alleviating mercury use and exposure within the mining process. This can be accomplished either through the implementation of a device that mitigates mercury exposure, or by eliminating the use of mercury in the mining process itself.

Retorts and fume hoods are used worldwide to provide health and environmental protection from the hazardous mercury vapours which result from the current ASM process. While these devices provide potential solutions to the health and safety challenges presented by in the mining process, they do not target the underlying issue of the use of mercury. Consequently, long term solutions should aim at removing mercury from the ASM process. This is possible with the use of alternatives such as cyanide and borax. These mercury-free processes provide safer mining conditions, but it may be difficult to persuade miners to change their extraction methods. Many miners have used mercury for their entire careers, and are reluctant to believe these alternatives can yield equivalent or improved results. Additionally, not all ore is suitable for these alternatives. Intensive testing on the ore must be conducted to determine the feasibility of implementing an alternate process that can sustainably replace mercury.

Retorting is used in small-scale gold mining to burn the gold-mercury amalgam in an enclosed device, typically manufactured from steel or iron (UN Environmental Program, 2012). The use of retorts encourages the reclamation of mercury, which is an “effective first step in moving towards mercury free processing” (UN Environmental Program, 2012). There are various types of retorts used around the world, and they have been implemented in most countries where ASM is prevalent (UN Environmental Program, 2012). As previously stated, miners are exposed to mercury vapour as they burn the amalgam of gold and mercury in open air. Retorts allow the amalgam to be burned in an enclosed space where the mercury is vaporized and the desired sponge gold remains. The mercury vapor is redirected into a condensation system, where it returns back into elemental liquid mercury, minimizing the release of effluent mercury into the environment. A retort is key for health and safety, but there is also the financial incentive of recovering the elemental mercury for future use, and consequently an increased profit. Conclusively, retorts present a practical solution to prevent exposure to mercury vapor from a health and environmental standpoint, and there have been efforts to implement the use of retorts around the world.

Ghana has a history of research and implementation regarding the use of retorts to mitigate the toxic side effects of mercury use in ASM. In the late 1990s, the Ghana Minerals Commission

introduced retorts to mining communities throughout the country to limit mercury contamination. However, the agency did not engage with local miners during the initiative and it failed to gain traction with miners. The miners criticized the device's long heating times due to indirect heating and lack of visibility of the amalgam during the process. To address the visual feedback concern, the Minerals Commission contracted a German based manufacturer to design a glass retort. Once again, miners were not included in the design process, and new concerns arose about the high cost, low capacity, and low durability (Hilson, 2006).

In a subsequent initiative, the Mineral Engineering Department at the University of Mines and Technology in Tarkwa, Ghana, built upon the glass retort with a lantern based design as seen in Figure 3 below. (Amankwah and Ofori-Sarpong, 2010).



Figure 3: Lantern Retort (Amankwah and Ofori-Sarpong, 2010)

In addition to being more durable and less costly, researchers found that there was a 95.2% recovery of mercury, providing a financial incentive for miners (Amankwah and Ofori-Sarpong, 2010). While the success of the retort in mitigating mercury exposure shows promise, the most recent literature on the program makes no mention of contact with miners during design, and refers to “education campaigns” that echo Parsons’s development done “to” rather than “with” people (Amankwah, Adjei, & Ofori-Sarpong, 2017). Despite technical performance, the “low success rates of the mercury retort implementation exercises in Ghana can be attributed to commissioned bodies failing to liaise with target communities beforehand” (Hilson, 2006). To this point, there are few significant examples in literature of mercury abatement initiatives in Ghana that

successfully interface with small scale gold miners. Thus, to avoid repeating the mistakes of past interventions, we must seek approaches grounded in partnership. Nonetheless, the acceptance and use of retorts in other regions in Ghana shows promise, and possibility of implementation in the Eastern Region (Amankwah and Ofori-Sarpong, 2010).

Another potential device that has been used globally is the fume hood. Fume hoods have been used in the mining process to mitigate exposure to noxious vapours, and are effective in redirecting effluent vapour. However, the shortcoming of the fume hood is its failure to recycle the mercury vapor back into its elemental form. The U.S. Department of Energy's Argonne National Laboratory, led by the Environmental Protection Agency (EPA) set out to reduce mercury emissions that are caused by small-scale mining practices in Brazil and Peru. Prior to designing and implementing the novel mercury capture attachment system, the group found that most gold-shops, which refine the sponge gold, have fume hoods in which they burn the amalgam. These fume hoods vent mercury vapor out into the environment, making them an effective tool in protecting miners and workers, but ineffective in environmental protection. The effluent mercury vapor released from these fume hoods can settle in local bodies of water where people obtain water for household use and catch fish for consumption (Breux, 2014). Fume hoods are therefore not an optimal solution for lessening the unsustainable use of mercury, nor do they mitigate the pollution to the environment and consequently the health of the local communities.

While retorts and fume hoods provide protection from mercury vapour, and mitigate some environmental concerns, it is important to emphasize that they do not tackle the underlying issue of mercury use as a whole. In some ways, the use of mercury is perpetuated by retorts as the device makes it safer and more economically feasible. Additionally, fume hoods do protect the direct users, but fail to protect those in the surrounding community. However, until an equally effective mercury-free process is developed and implemented, these devices provide protection and minimize environmental hazards in ASM.

There are a number of mercury-free processes that completely eliminate the use of mercury in ASM. Cyanide can be used as an alternative to mercury in the gold mining process. Cyanide has a strong affinity for metals, and it is used for selective leaching of metals such as gold from ores. It is also highly toxic, and it is crucial to regulate and limit the amount of cyanide that may be discharged into the environment. Despite these risks, cyanide has emerged as a more efficient and less toxic alternative to mercury-based gold mining (Nyamunda, B. C., 2017).

Cyanide is naturally occurring in cassava, a root vegetable abundant in Western Africa. One potential extraction process for removing cyanide from cassava starts with sun drying the intact roots either whole, or in large pieces. Once dried, the brittle material is pounded, sieved, and the remainder left is a white flour, which is around 12-16% concentrated cyanide (Bradbury, 2007). This can then be refined by creating a paste of water and flour, then spreading the mixture in a thin layer over a basket. This mixture sits in the shade outdoors for four to five hours while the enzymes break down to produce cyanide. This process is optimized in the dry seasons, where a lack of water produces more cyanide in the roots (Bradbury, J. H. et. al, 2007).

Although the usage of cyanide is an alternative that can be sourced naturally, the size of the gold particles in the ore greatly affects the percentage of gold recovered. For cyanidation to be effective, the gold particles must be present in fine grains, less than 0.2 mm. Therefore, cyanidation cannot be implemented everywhere due to the differing characteristics of ore in various regions. Conversely, mercury cannot effectively amalgamate fine gold particles less than 0.07 mm. Chemically, the processes are also drastically different. Cyanidation, is a process that dissolves the gold into solution. Meanwhile, amalgamation is a process where surface bonds form between the metals, resulting in the coalition of gold grains rather than dissolution into the mercury. Microscopical analysis must be done on the gold particles to determine the most efficient procedure (Hylander, L. D., Plath, D., Miranda, C. R., Lücke, S., Öhlander, J., & Rivera, A. T. , 2007).

Another mercury-free gold extraction method was invented in the Philippines using borax. Borax, which is hydrated sodium tetraborate, is a common component of many detergents (Peter W.U. Appel, PhD1; Leoncio Na-Oy2, 2012). The borax method has proven to extract up to twice as much gold without the need to invest in new processing equipment and without longer processing time (Appel, P.W.U. and Na-Oy, L.D, 2014). Similarly to the mercury extraction process, a heavy mineral concentrate is made of water and crushed up ore. This mixture is produced by gravitation, which is the separation of gold and other heavy metals from lighter, less dense particles in the ore. Borax is then added to the mixture, effectively reducing the melting point of gold and other heavy minerals. This enables the gold to be melted out of the ore, as gold has the highest atomic weight and will sink, separating it from the other heavy metals. The borax method is inexpensive, readily available, and has been gradually adopted by around 20,000 small-scale miners (Appel, P.W.U. and Na-Oy, L.D, 2014). By switching from mercury to borax, small scale

miners can earn more money and reduce their contribution to global mercury pollution. Dissimilarly to mercury's known hazardous effects, recent research has shown that the use of borax has negligible health and environmental impacts (Appel, P.W.U. and Na-Oy, L.D, 2014).

However, the borax method is not appropriate for all types of gold ores. Some ores with very fine grain sizes or high sulfur content may not be amenable. Before implementing the borax method, the gold ore in the community needs to be tested to see whether borax is appropriate for that locale. Further research of the effectiveness of borax in different ores and grain sizes still needs to be done, limiting the potential of borax being implemented as an alternative method at present (Peter W.U. Appel, PhD1; Leoncio Na-Oy2, 2012).

CROSS CULTURAL DESIGN

Effective cross cultural design necessitates working with, rather than for, project partners in a co-evolutionary design process. As MIT professor Susan Murcott explains, “Co-evolutionary design goes beyond the dualism of ‘the project’ and ‘the community.’” It is a “collaborative process” in which the communities are not considered a consumer of the product, but rather “partners and experts in their own local conditions.” (Murcott, 2007). Solving problems in a cross-cultural environment requires expertise that neither group could be expected to have on their own. Both groups are meant to benefit from the knowledge that the other possesses, and by rooting design in partnership, communities will more readily understand the intended impacts of these interventions, and be empowered to shape their own outcomes. This process, as shown in Figure 4 below, includes many of the same aspects of the traditional Western engineering design process, but builds upon it by keeping local knowledge, resources, and capabilities central through every step of the cycle.

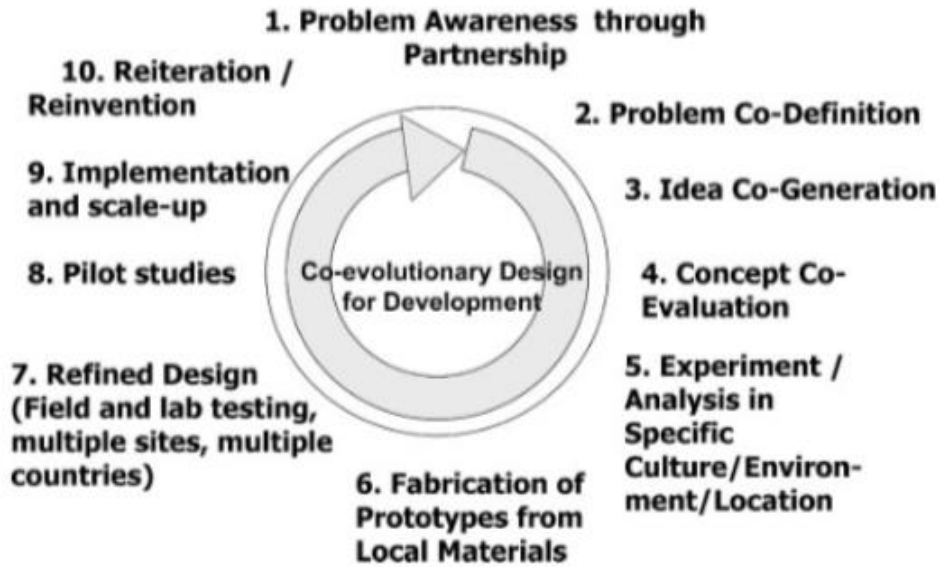

Figure 4: Co-Evolutionary Design Process for Development

Globally, co-evolutionary approaches in the small scale mining sector have led to interventions that have been readily adapted and successfully maintained. As previously mentioned, engineers from the United States Environmental Protection Agency in conjunction with the Argonne National Laboratory spent three years designing a mercury capture system for use in gold shops. The designers collaborated with local shop owners in an iterative process, and took special care to ensure that the cost, materials, and fabrication of the device aligned with local requirements and capacity. The device functions well technically, and passed pilot studies with users in Brazil and Peru (Breux, 2014).

In Tanzania, an East African country with an active small scale mining industry, retorts have become a requirement by the mining legislation (Jonsson, Appel & Chibunda, 2009). A paper published in the Journal of Cleaner Production details the co-design, testing and implementation of an iron retort in two mining communities. This study demonstrates how a locally made retort constitutes a feasible way to address the highly unsustainable consumption of mercury in the mining sector (Jonsson, Appel & Chibunda, 2009).

Although both of these examples present useful techniques, technologies, and ideas, these successes cannot simply be replicated without context in other mining communities around the world. For this reason, we have an opportunity to employ co-evolutionary design to improve the health and environmental safety of miners and their communities in Ghana.

CHAPTER 3: METHODOLOGY

CROSS-CULTURAL DESIGN AND CO-DESIGN

Before arriving in Ghana, we completed preliminary research to prepare us for our study from a co-design perspective. This included the history of mining in Ghana, the mining process, the health and environmental hazards associated with mercury, potential solutions to combat these negative impacts, and past relevant mitigation interventions.

Our research was valuable for understanding context and technical considerations of ASM, however we were unfamiliar with local processes. We upheld the notion that we are experts in chemical and mechanical engineering, and that the miners are experts in ASM. Cross cultural and co-design emphasizes the importance of collaborating directly with locals as equal partners and utilizing local resources throughout the design.

Developing rapport amongst collaborators on this study was essential for the co-design process. This is not a stepwise procedure, but rather the continual establishment of a strong working relationship. Our local partner agency, the Okyeman Environmental Foundation, set up an initial introduction between us and the miners to set a foundation for our partnership. Throughout the design process, we met with the miners every week to build our relationship through shared food, gifts, meeting their family, and seeing their home, all while working on co-designing an ASM safety device together.

TIMELINE

This study took place over two months in Kyebi, Eastern Region, Ghana. The mine site was located in Osino, Eastern Region, Ghana. We observed the mining site multiple times, during both inactive and active work days. During our inactive mine site visit our guides were the only miners present, and no mining operations took place. When the mines were active, there were approximately seven groups of working miners that contained 15 to 30 members each. Our design criteria was gathered through collaborative workshops with these miners. Multiple prototypes were made throughout the co-design process, each building on earlier iterations. **Figure 5** outlines the steps of our design, prototyping, and testing.

WEEK OBJECTIVE

1	- Initial contact made with Okyeman Environmental Foundation to set up first meeting with miners
2	- Initial meeting with miners - First inactive mine visit to explain mining process
3	- First active mine visit to observe a live mine - First workshop with miners to establish design criteria and initial prototype idea
4	- First prototype commissioned with local welder - First prototype received - Second workshop with miners to discuss iteration of next prototype - Second prototype commissioned with local welder
5	- Second prototype received - Second prototype modified with miners and welder - Third and final prototype developed at third workshop
6	- Second active mine visit for cost analysis conversation and social data collection
7	- Third and final active mine visit for cost analysis results - Final prototype decision made
8	- Operation and maintenance manuals created

Figure 5: Study Timeline in Ghana

SOCIAL DATA COLLECTION

Our team utilized ethnographic techniques to co-define the problem and co-create a solution. These techniques, including participant observation and design workshops, were the basis for our practical engagement with our partners in Osino, and facilitated knowledge transfer between ourselves and the miners. Further, these techniques encouraged us, as outsiders, to understand and consider our own perspective as it relates to our study.

Participant observation is one of the many methods used in fieldwork to understand the points of view of the locals and to form relationships with them. This technique was used during our interactions with the mining community. As anthropologist Bronislaw Malinowski defines, participant observation is an intensive, long-term engagement with a group of people in one location (Mannik and McGarry, 2017). Participant observation is a knowledge building activity, used to gain contextual understanding of local's perspective and practices in an informal manner. This method may involve learning the local language, participating in daily tasks, and observing the local's way of life. We used participant observation to build rapport with the miners, identify their wants and needs for the device, and develop prototypes. We aimed to minimize the disruption in the work life of the miners, and maintained flexibility to meet miners in the spaces and times that worked best for them.

Mine visits gave us the opportunity to understand the mining process and build rapport with the miners. Before each of the mine visits we developed agendas to define critical questions and goals for observation as seen in Appendix A. The initial visit focused on understanding the gold mining process and how mercury is used. Later visits focused on showcasing the co-designed prototypes and gathering feedback on operation and cost from other miners.

We used workshops to directly collaborate with miners for ideation and experimentation. These workshops took place in a neutral location, typically the University College of Agriculture and Environmental Studies at Bunso or a local restaurant. Workshops were organized as interactive unstructured meetings, beginning with an informal catch up and moving into an open discussion of the project and brainstorming. The small group setting created a relaxed environment in which the miners were encouraged to share their opinions and responses to topics. One team member was designated as a note taker for each workshop, allowing the rest of the team to be engaged and active in the discussions. The workshops relied on sketching design ideas, which helped mitigate language barriers while providing a visual means of communication. This collaborative structure of the workshops was an integral part of co-designing the device. Plans for each workshop are shown in Appendix B.

When developing questions for our interactions with the miners, language was very important to ensure the miners felt comfortable. As we did not share a common language proficiency, the team understood the importance of asking questions in various wordings. It was essential to reiterate a question with different wording throughout the conversations to arrive at a

clear and complete answer. Open-ended questions were used as they were the best way to learn about cultural practices and meanings, and ensured questions were not leading which would suggest that there is a right answer. Non-judgemental wording was vital to ensure the miner did not feel threatened, judged, or confused in any way. The question order was also important to maintain the flow of conversation and promote deeper thinking and elaboration. (Mannik and McGarry, 2017).

Voice recorders were only used if the miner felt comfortable being recorded. If the miner was recorded, the tape recorded was hidden to prevent distraction throughout the meeting. During our early interactions, we did not use electronics as taking notes on a laptop could have made the miner feel intimidated, potentially destroying the intimacy between the us and the miner (Mannik and McGarry, 2017).

TECHNICAL DATA COLLECTION

After the prototypes were assembled, they were tested and analyzed to ensure alignment with the previously determined design objectives. First, each prototype was measured to ensure that the dimensions matched those that were given to the welder. While testing the prototypes, it was important to gather both quantitative and qualitative data. Testing included static analysis, leak tests and static analysis. The design was also evaluated for durability, ease of use, and reduction in exposure of mercury. Lastly, an Operations Safety and Maintenance Manual was created to guide miners or organizations that may use the device in the future.

1. Leak Test

A leak test was done on each prototype to visually inspect the device for leaks. This was done by burning a piece of paper within the device. Multiple trials were conducted to ensure all vapor would be contained within the device. If a leak was detected, the device was brought back to the welder to seal any gaps in the welding. In addition to the leak test, these initial burns removed any impurities in the metal used to manufacture the device that could potentially lead to gold discoloration.

2. Prototype Questionnaire

Once a device was analyzed for leaks, the miner tested the device with the mercury amalgam. The miner was instructed to use the device multiple times. Once the miner conducted a multitude of trials, a discussion ensued to gather feedback on the design. To aid in this discussion, a questionnaire was developed to gather information based on the initial design requirements. The questionnaire provided written feedback from the miner on the device's ease of use and ability to be incorporated into the amalgamation process. The miner was also asked to note other observations such as any abnormal changes in gold color, visible leakage, and the duration of amalgamation process. Results from the questionnaire were used to develop further iterations of the device. Copies of these questionnaires can be found in Appendix C.

3. Static Analysis

Each of the design iterations were static systems that were not subjected to any significant loads during operation. A static failure analysis was done on the final device, as shown in Appendix E. This static analysis allowed us to determine how much force it would take to dent, crush or bend the various parts of the device. If the force we calculated was much higher than anything the device would actually experience, we were able to recommend a reduction in the thickness of the steel used so that the cost and weight of the device could be minimized.

4. Operations Safety and Maintenance Manual

Once a final design was manufactured an operations, safety and maintenance manual was created to facilitate the implementation and usage of the retort. The manual was designed to help guide the use of this report for small scale miners. It provides guidance for individual miners, mining communities, and for any agencies trying to replicate this design. One of the key messages in the guide that has not often been clearly described is that retorts, although simple in design, have operational requirements that must be followed to avoid increasing human and environmental exposure. Copies of the manual can be found in Appendix D.

FINDINGS

PROTOTYPE 1

To begin the design process, an initial meeting was organized by our sponsor, a member of the Okyeman Environment Foundation. This meeting was attended by two local miners, our professor, and the Okyeman Environment Foundation. During this initial meeting, we learned that the miners were registered through a mining organization, and that they sold their gold to Precious Mineral Marketing Company. The average workday of a miner is an 8-hour shift, which can either occur during the day or night. We learned that for 50 GHS, a miner can buy 1 tablespoon of mercury. One tablespoon of mercury can amalgamate 5 pounds of gold, which can be sold for 10,000 GHS. The miners also detailed a basic overview of the mining process, which included the crushing of the ore and rock, the amalgamation process involving mercury, and the vaporization process of the amalgam to obtain sponge gold. In addition to being exposed to mercury through dermal contact and inhalation, it also became evident that some miners place the mercury-gold amalgam into their mouths to draw out excess mercury, thereby ingesting the element. The miners recognized the mercury as a major health hazard, and described the effects of mercury poisoning that they had observed in themselves and fellow miners. In addition, the meeting served as the first step in building rapport with the miners, as it gave us an opportunity to introduce ourselves on a more personal level, and learn about the lives of the miners.

At the close of this meeting, we were invited to accompany the miners to an inactive mining site. The miners explained the process without power or running water. At this site, we asked the questions seen in Appendix A. This visit allowed us to see the tools and some of the techniques in person, which allowed us to develop ideas about where a mining safety device could be implemented in the process. Later, we visited an active mine site to further solidify the details of the process. There, we observed most of the miners working without any personal protective equipment, aside from some men wearing rubber boots. Women and children were present at the site, in addition to about 50 men. We were told by the miners that they amalgamate the mercury and gold on site but bring it in a handkerchief or small bottle to an offsite location to burn for security reasons.

At our first design workshop following the inactive mine visit, we met with the miners to co-define the problem and began iterating potential solutions. Our agenda can be seen in Appendix B. To co-define the problem, we first asked the miners what issues and problems they saw in ASM. The miners stated that the health effects associated with ASM was their biggest concern. By co-defining the problem and purpose of the project, the miners saw and understood the value of the prototype. With this foundation, as a group we discussed our mutual goals for the device. Together we developed a design criteria that can be seen below in Table 2.

Table 2: Co-Design Criteria Developed After First Workshop with the Miners

Hierarchy	Category	Description
0	Partnership and Adoption	Device must be designed with miners as equal partners so it will be readily integrated into the practices.
1.1	Personal Safety – Vapor	Device must protect users from exposure to mercury vapor during the burning of amalgam.
1.2	Environmental Safety	Device must protect the surrounding environment for mercury and vapor.
2.1	Materials and Fabrication	Device must be manufactured using local materials and fabrication techniques.
2.2	Adoption – Heating	Device must be comparable in procedure and effectiveness to current practices. Device must allow for direct heating of amalgam from blowtorch.
2.3	Adoption – Visual	Device must be comparable in procedure and effectiveness to current practices. Device must allow miners to check on the amalgam while it is being burned.
2.4	Affordability	Device should be relatively inexpensive to manufacture and repair based on miners’ incomes.
2.5	Durability	Device must be able to withstand the wear and tear from basic operation or drops/accidents on the mine site.

2.6	Portability	Device should be easily transportable between different mine sites and the miners home without damage.
2.7	Repairs	Device must be easy for miners to repair using locally available materials.
3.1	Reclamation	Device can reclaim mercury for later use.
3.2	Personal Safety – Contact	Device protects miners from dermal contact with mercury during the creation of amalgam.
3.3	Replication	Device can provide economic opportunity through manufacturing and sale.

Prior to the workshop, we believed that mercury reclamation would be higher on the design criteria, however once we discussed it with the miners, the economic incentive was not as important to them as safety. After learning this, we discussed each step of the amalgamation process that is associated with mercury exposure to the miners to determine what area to focus on in the device. In the beginning steps of the amalgamation process, the miners stated that the dermal contact that stems from the rubbing of the amalgam between the palms of the hands was a necessary step. This rubbing motion allows for the small pieces of gold dust and fine grains to be incorporated fully into the mercury. After some discussion, we decided that if the miners had gloves that were mercury resistant, they would still be able to feel the consistency of the amalgam between their hands. Because this problem could be fixed by having a supplier start selling gloves in Osino, we instead decided to focus on the vaporization of the mercury.

After further outlining our design criteria with the miners, we decided that their personal safety and the safety of the environment around the amalgam vaporization process was the most important criteria the design needed to fulfill. Based on our knowledge of engineering and past interventions, a retort was decided on being a suitable device that would address the main criteria.

Before we co-designed a retort, the miner developed his own design based on the criteria and details we had previously discussed. The schematic he drew is seen below, in Figure 6. His design featured a base container that the amalgam could be placed in, with a hole large enough for the miner to burn the amalgam with a blow torch and observe the color changes from silver to yellow as the gold is purified. The vapor would be directed out of the top of the pipe that leads

from the base, and away from the miner that would be using the device. All stakeholders agreed on the device, and we went to the local welder. Upon arrival, we presented the drawing to the welder and it was approved as a feasible design after explaining the mercury burning process it would be utilized for. The welder said he could make the device out of galvanized steel, which we knew through research was a feasible material for the vaporization of mercury, and it would cost 100 GHS.

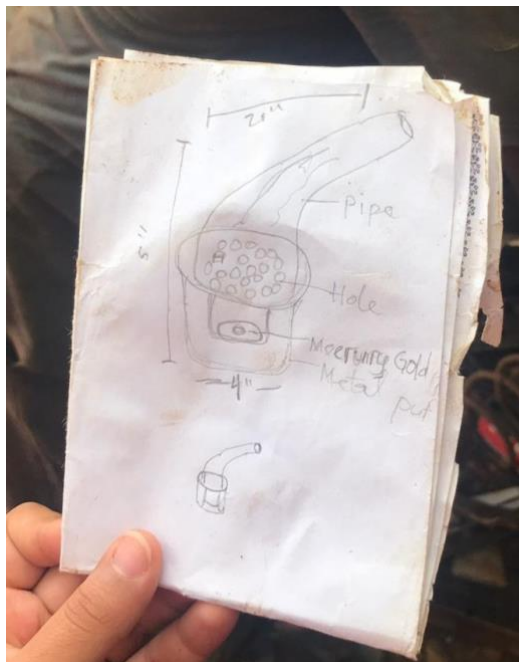

Figure 6: Photo of Osino Miner's Design

The miner picked up the device the following day, shown in Figure 7 below, and we met to conduct some preliminary testing. The first test was a leak test, in which we burned a piece of paper in the device. We observed large amounts of smoke escaping through the blow torch hole, and the rest of the smoke travelling up throughout the pipe, but no leaks in the actual structure of the device. We took the dimensions of the device and let the miner use mercury to see how the vapor would behave.

We met with the miner again after he had the chance to try the device with mercury. In addition to discussing his observations and thoughts of the device, we also asked him to answer a questionnaire, seen in Appendix C, to better understand what he thought about the device while he used it. The miner stated that it was “perfect because the smoke will pass through the pipe.”

Additionally, he believed it was easy to transport the device, as the handle and size of the device aided in that.



Figure 7: Photo of Prototype 1

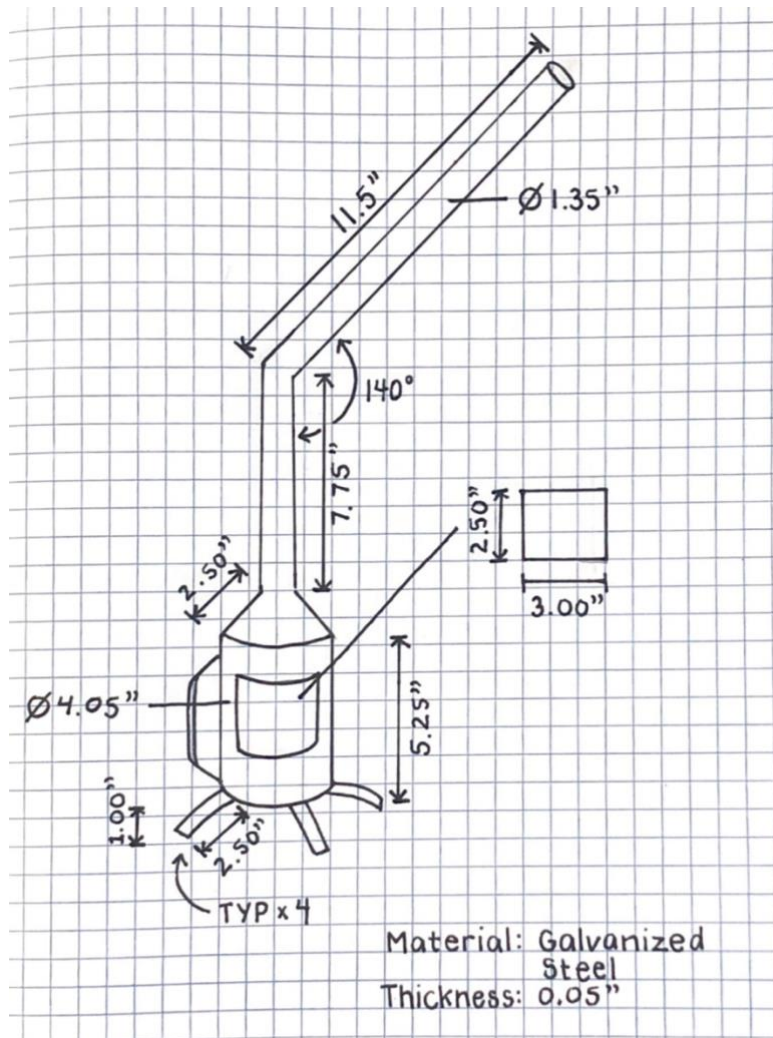

Figure 8: Technical Drawing of Prototype 1

PROTOTYPE 2 AND PROTOTYPE 2.5

As mentioned, our first prototype was designed with the miner, as an equal partner, to be readily integrated into his vaporization techniques. After multiple trials with the first prototype, the miner noted many critical observations. First, he stated that the white vapor, typically seen when burning the amalgam, was observed at the outlet of the device. Although the miner liked that the smoke was controlled and contained by the angled pipe, the mercury vapor was still polluting the local environment, and could be unintentionally inhaled despite being redirected.

Based on the miner's observations, we had our second design ideation workshop. This workshop focused on brainstorming possible designs that could potentially condense the mercury vapor. Condensing the vaporized mercury back into liquid mercury, would not only eliminate the

risk of potentially inhaling the vapor, but it would also give the miner an opportunity to recycle the mercury and tackle the environmental degradation consequence of ASM. The following designs were co-designed with the miner.

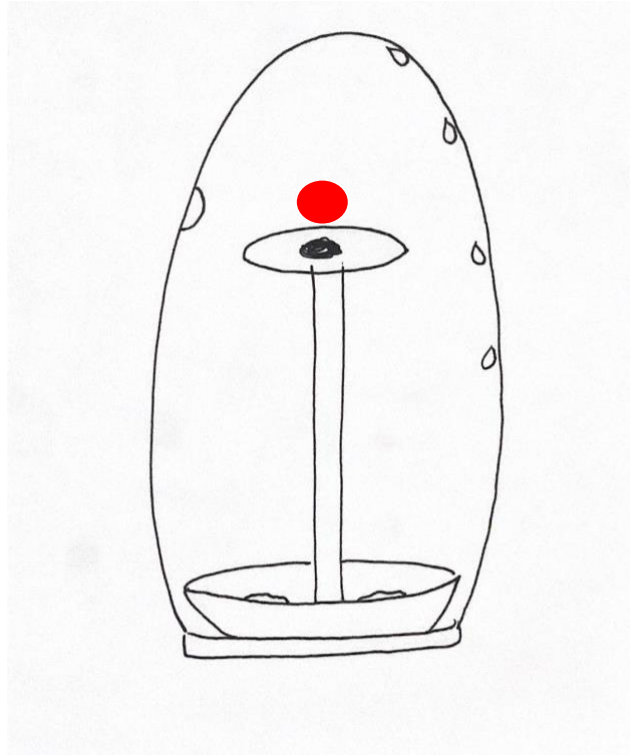

Figure 9: Developed Closed System Design

Figure 9, shows a closed system design. The amalgam, shown in red, would be placed on a stand. The hole shown on the left of the amalgam would be concentric with the diameter of the blow torch allowing for direct heating of the amalgam. In theory, the mercury vapor would rise during vaporization and coalesce down the sides of the device as it condensed. The walls of the device would have to effectively cool the mercury vapor as it travelled to the bottom of the device. Wet rags could potentially be added around the device to promote condensation.

Although this design could have potentially worked, this design was not chosen for a multitude of reasons. First, this design would require multiple parts; these include the stand for the amalgam, which would have to be connected, potentially even threaded, to the bottom bowl for mercury collection, and the outside condensation walls. We wanted to keep our designs simple, with limited parts that would not require frequent replacements. Additionally, with this design there was a risk for accidental mercury vapor exposure. This could occur if the miner tried to

retrieve the final sponge gold product too early, and removed the condensation walls, without the mercury having been fully condensed. This design also has no visual indicator, unless the case was made of glass, that the mercury was fully condensed. Glass was not a material option, as it would be too fragile for the rugged terrain involved in ASM. Our final device would need to incorporate durable materials with a simple design, and have a place to easily insert and remove the amalgam, without putting the miners at risk for exposure.

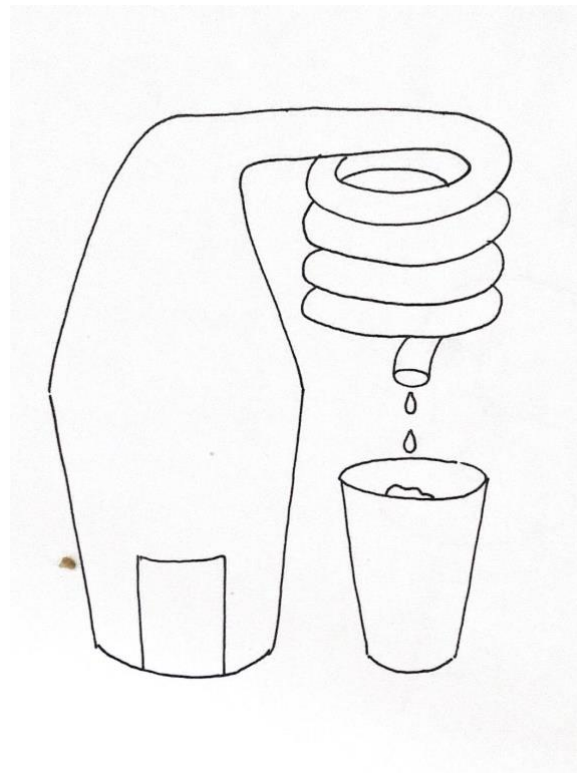

Figure 10: Coiled Pipe Condensation System Design

Together we co-designed another device that kept the simple elements of the first design, but used our engineering expertise to incorporate a coiled pipe condensation system as shown in Figure 10. The heating vessel remained identical to our first prototype as the miner enjoyed the ability to directly heat the amalgam and the accessibility to the amalgam. The use of coils increased the length of the pipe, thus increasing the surface area and promoting condensation without hindering the portability of the device. The use of wet rags was also implemented to promote condensation.

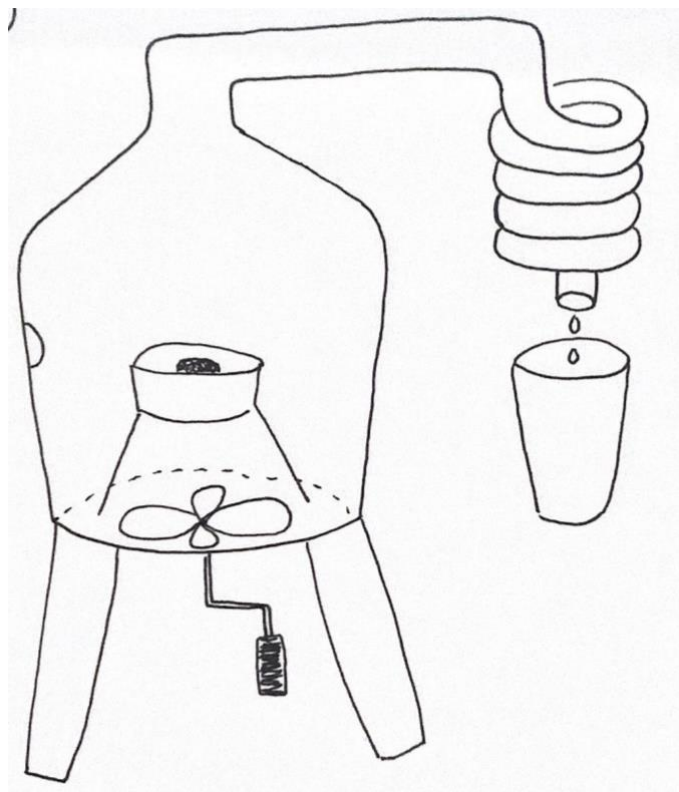

Figure 11: Coiled Pipe Condensation System Design with Fan

Another version of the condensation pipe system was discussed that included the addition of a fan, as pictured in Figure 11. The use of the fan would have been two-fold, first facilitating the movement of the vapor and second helping to cool down the sponge gold product after burning. The potential use of a fan was discussed with the miners but ultimately proven not to be a priority for them; they did not mind having to wait for the gold to cool after burning. The fan could also potentially interfere with the blowtorch flame and would require a power source such as electricity or batteries that would be an added cost to the device. Together, we decided that although the addition of a fan could be useful in a strategic location within the device, the added expense of power made the addition not worth pursuing. We wanted to first address the issue of containing the hazardous mercury vapor, before adding complex additions such as a fan that would require maintenance and a power source.

The group also decided that the addition of a door on the burning vessel would be extremely beneficial. Although the door would be open during the burning of the amalgam, the miner would close the door after vaporization. This would protect the miners from any remaining vapor that could potentially escape from the burning vessel opening.

After our second ideology deep dive, we decided to manufacture Figure 12. Our designs were brought to the same welder that fabricated prototype one. The welder informed us that Prototype 2 would cost three times as much, at 300 GHS. This increase in cost was due to travel that the welder would have to make to Accra, the capital of Ghana, to bend the metal for the condensation pipes. The finished prototype can be seen in Figure 12, and technical drawings can be seen in Figure 13 and Figure 14.



Figure 12: Photo of Prototype 2

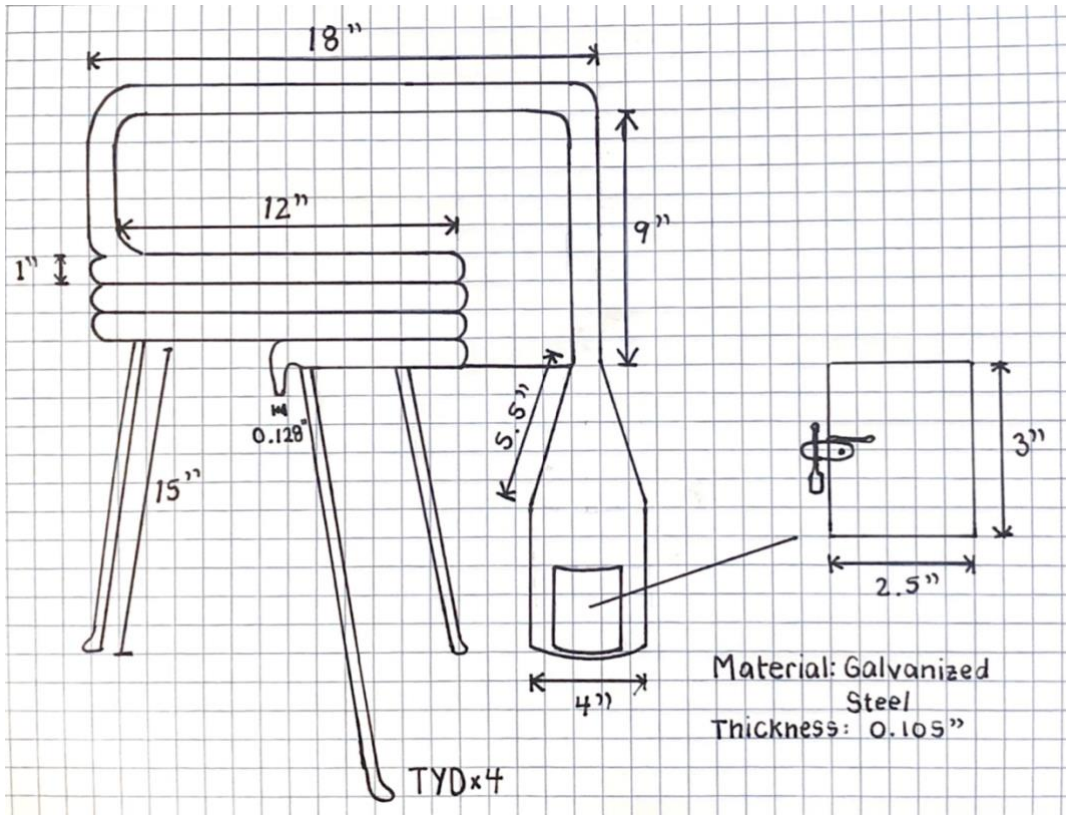

Figure 13: Technical Drawing of Prototype 2 Side View

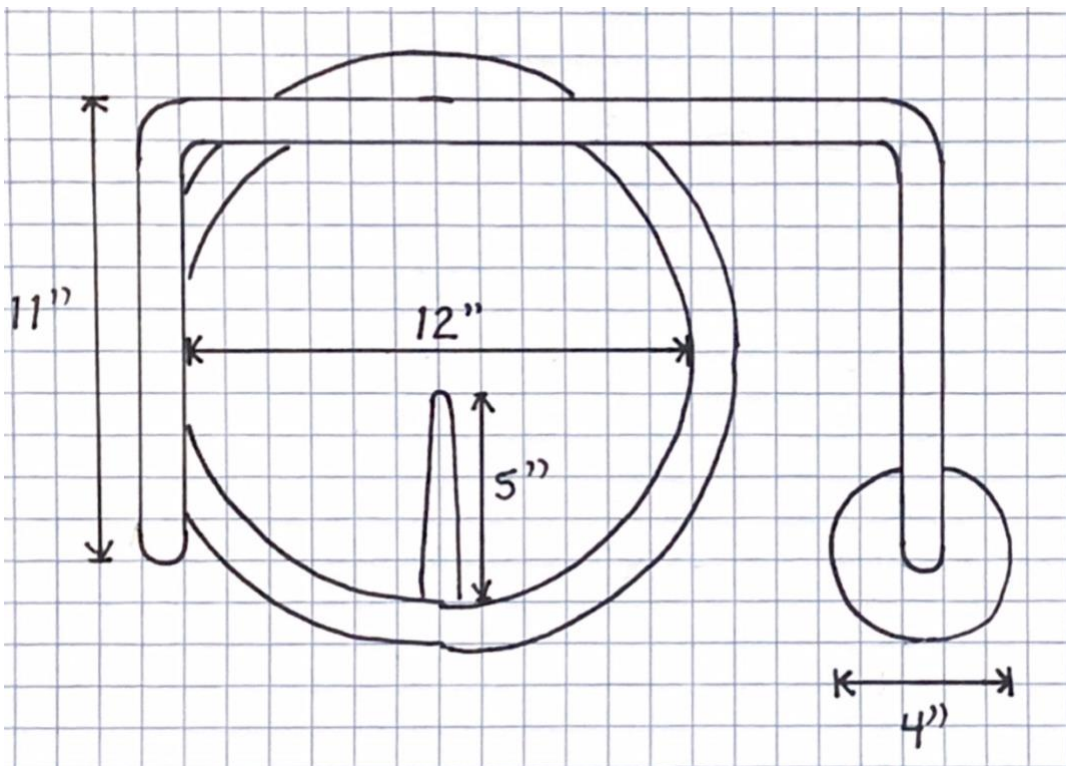

Figure 14: Technical Drawing of Prototype 2 Top View

Once the second iteration was manufactured, we performed our routine leak test to ensure no gaps would accidentally expose the miner to the mercury vapor. During leak test trials we saw smoke escaping from welding gaps behind the burning vessel as seen the red circle in Figure 15.

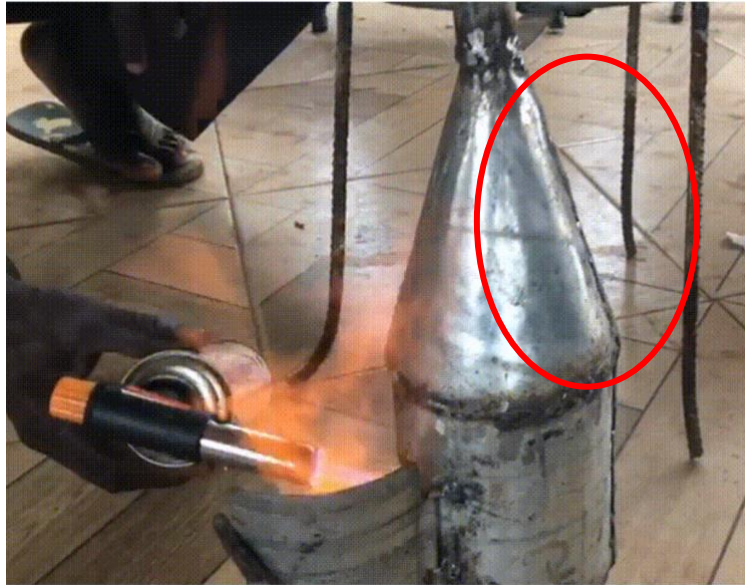

Figure 15: Leak Test of Prototype 2

The device was then brought back to the welder to fix the gaps. Upon arrival, the miner described and explained the device to the other welders and workers present. The lead welder and his workers began to give feedback on the device. Together the miner and welders suggested the addition of a spout on the side of the burning vessel as shown in Figure 16.



Figure 16: Modified Burning Vessel

The purpose of the spout was to allow for direct heating of the amalgam by allowing the miner to place the tip of the blow torch into the hole. As shown in Figure 17, the spout was angled and the diameter was slightly larger than the diameter of the blow torch. The blow torch could easily fit in the spout and the flame had direct contact with the amalgam, without being held by the welder. This would further minimize vapor leakage as the door on the burning vessel could remain closed for the entire length of the burning. Although this eliminated the miner's initial design criteria being able to see the amalgam while it was burning, he was able to compromise this requirement for improved vapor control.

With these modifications, the sole purpose of the door was to place the amalgam in the device and remove the sponge gold out of the device. With the door now completely sealing the device, and the welding gaps fixed, the vapor had no choice but to travel through the condensation pipes.



Figure 17: Photo of Prototype 2.5

FINAL ITERATION - PROTOTYPE 3

The miner then had the opportunity to test the slightly modified prototype. The team once again met in the miner's restaurant to discuss his observations during testing, and how these

observations would impact the third design. For the third and final iteration of the design, the miner said that he would like to keep the small entry hole for the blow torch; this hole allowed for a direct heating of the amalgam, and also allowed the torch to be propped against the side of the device, which made the process hands free. He also requested that the door for placing and removing the amalgam be moved to the back of the device. This was to ensure that if the integrity of the door was ever compromised, the leak would be as far from the miner as possible.

In terms of the condensation aspect of the device, the miner had observed that although no mercury vapors were seen coming from the exit spout, no liquid mercury was seen dripping from the spout either. The miner came to the conclusion that after multiple uses, the mercury would eventually begin to collect and come out of the device. Mercury reclamation was not a major goal of his in the creation of the device, and he was pleased that no mercury vapor could be seen.

Although no vapor was seen by the miner during his observations, we wanted to further improve the condensation system so that the liquid mercury would more readily come out of the coils with subsequent burnings. To do so, we discussed inserting 2 inch separations between the coils with the miner. He agreed that these separations would make it easier to tie more wet clothes around the coils, which would improve the cooling of the coils. Additionally, the overall shape of the coil system was designed to taper inwards, creating a cone-like shape. The team suggested this design to the miner to direct the liquid mercury out of the coils with the sharper angles and steepness of the cone shape.

We brought this new design to the welder, and he informed us that this version of the device would be 100 GHS more expensive than the previous version. Before commissioning the device, we decided to return to the mine site once again to discuss costs with the various groups of miners. This was to ensure that we were designing a device that the miners would be able to afford; we did not see the value in commissioning a prototype that the miners would never consider. We accompanied the miner to the mines, and went around to the 7 different groups at the site. The miner explained the purpose of the device to each group in Twi, answered questions that they had, and translated their responses to us in English. Although some of the responses varied, the overall consensus was that 150 to 200 GHS was a reasonable price for the device.

Unfortunately, the welder had told us that the third device would cost around 400 GHS to build, and our previous iteration had cost 300 GHS, both being far outside of the price range that the miners had stated. The welder was unable to negotiate the price down for a single device, but

we learned that for bulk orders, he would be able to discount the overall price. For example, if 100 devices were ordered, he would be able to discount each device by 100 GHS. We also learned that having various environmental or governmental organizations subsidize some of the cost of the devices was a possibility. Based on this information, we decided to go ahead with the commissioning of the third design.

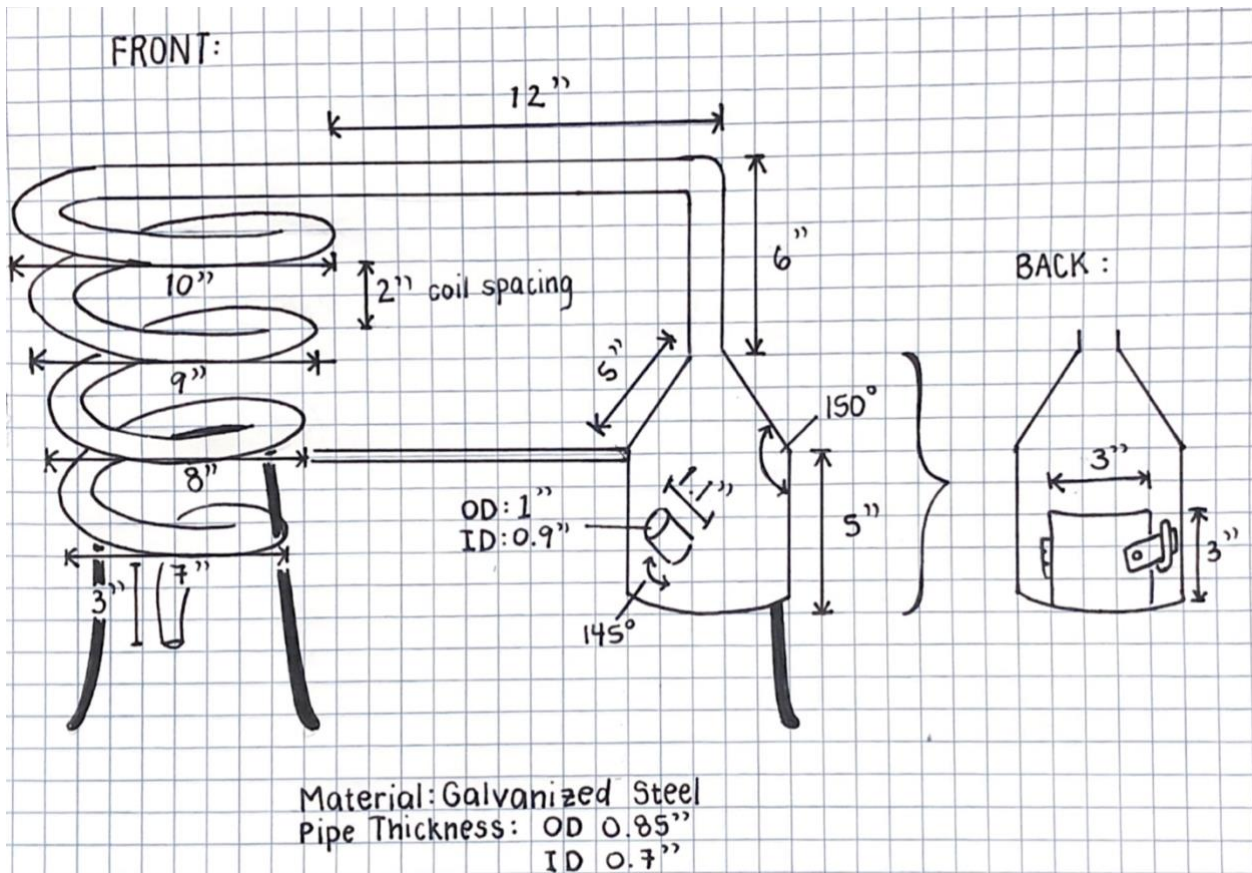

Figure 18: Final Device Technical Drawing

A structural failure analysis was conducted to assess the durability of the device. Although the device will not experience any significant loads during regular operation, it may experience accidental drops in the chaotic environment of the mine site. Using a <2% of pipe diameter allowable dent threshold and assumed drop height of 2 m, the analysis found that the device will hold up to reasonable expected damage. The full analysis can be seen in Appendix E.

Due to time restraints, we were unable to meet again with the miner after he had the opportunity to test the third prototype. Instead, an identical prototype was commissioned by the miner and brought back to the United States to undergo laboratory testing. During our last visit

with the miner, we had a discussion about his takeaways of the co-design process, and this can be found in Appendix F. The miner detailed that he enjoyed working with the group, and that he has learned how to prevent mercury poisoning. In an initial discussion, the miner expressed his opinion on foreign scientists, stating that they often come in with predetermined ideas and impose changes on the community. The group asked if this sentiment has changed over the course of our work together. The miner stated that he saw how we worked with him and made the effort to become friends. He emphasized the significance of our restaurant visits, mine visits and brainstorming workshop sessions. He added that we had physical evidence of our claims and he felt that his ideas were heard. The miner concluded that overall, he feels that he can now take charge and educate and advise his friends to be safer in the mining process and try to make a difference in his community.

RECOMMENDATIONS

Given the broad scope of this project, the team has developed a number of recommendations for future work, as this is a continuous process of iterative design, implementation and community engagement. As this initiative moves forward over time, it is important to form partnerships with more miners and community members. This will provide a greater pool of ideas and input to both improve and implement the use of a retort in ASM. Our team worked closely with one miner in the community, and he was highly involved in every step of the co-design process. If similar rapport and relationships were built with more miners, welders, and other members of the community, there would be a greater sense of ownership of the device within the community as a whole, and this would ensure the long-term sustainability of the initiative.

An essential part of testing the efficacy of the final prototype is conducting laboratory tests to quantify the success of the retort. Given the lack of laboratory space available in proximity to our location, the group was only able to perform basic testing. We recommend that higher-level lab testing should be done on the device in a remote lab space. Prior to performing any testing, one must complete the required training on how to handle mercury, with the appropriate personal protective gear and a fume hood. Following the necessary precautions, a gas syringe test may be used to measure the volume of mercury vapor leaving the retort. The volume of mercury vapor will displace the plunger of the syringe and quantify the volume of the evolved gas. This test will yield quantitative evidence to measure the success of the prototype, and any testing of future iterations of the device may use a similar method.

Another critical part of implementation of the device is the affordability to the miners. While the group has developed an initial understanding of the price range most miners would like to pay for the device, a more in-depth analysis is needed for a wider scope of implementation. Future groups could perform an affordability analysis by collecting data on the average yearly income of a miner, and their common expenses such as food, clothing, children, to show what percent of their income is needed to purchase a retort, without impeding on their day-to-day lives. Discussing the implementation plan with the Okeyman Environment Foundation, to help alleviate the potential cost for the miner and promote use of the device for health and environmental safety, the cost could be included in the registration to receive a mining license, with a retort given to the miner at the time registration is granted. Alternatively, the United States Agency for International

Development or the United Nations Development Programme could distribute a number to active miners and complete studies to see the health and safety effects of using the retort.

Additionally, future groups may be able to optimize the size of the retort and in turn the cost, by using the static analysis data from this paper. The static analysis shows how much force each part of the retort may withstand, and the results show that the retort will withstand forces higher than anything it will experience during use. This indicates that the thickness of the steel used may be reduced, and consequently this minimizes the cost of the retort, as well as the portability as the weight of the device would decrease. This optimization could improve the affordability of the device for a larger number of miners, and increase the positive impact on the ASM community.

While retorts are highly effective in improving the safety and health of the mining community, it is critical to understand that they are a step towards a mercury-free mining process. The end goal for ASM is to completely move away from using mercury, and eliminate any and all associated risks to health and the environment. Assessing awareness of alternative methods and potential for educational initiatives are steps to attain this overarching goal. We have learned that borax is used for gold refining in the gold shops, and this indicates the existing knowledge and existence of the safer borax process. Future groups could work in partnership with the gold shops and the miners to transfer some of the borax process knowledge to the miners to initiate moving towards this mercury-free process. This type of drastic change in mining requires a significant period of time to propose as well as implement, but it is the long-term end goal.

CONCLUSIONS

This study has been a transformative cross-cultural exercise, not only in achieving sustaining technical intervention, but in empowering local experts to shape their own outcomes. The lessons we have taken from this experience come primarily from our co-design process, and can be applied in development applications both in ASM and beyond.

Co-design for development of a device can struggle to adhere to planned agendas due to unforeseen circumstances, such as last-minute rescheduling of a meeting. Thus, the need for adaptability in the process is inevitable and invaluable. We spent our first two weeks building rapport with the miners, understanding the mining process, and planning before we started developing designs. Strong relationships in design partnerships were developed to be the most important aspect of the co-design process. In cross-cultural design, this is especially evident as there are social and cultural norms that are variant, requiring adaptation from all partners. We built relationships through shared activities, and this foundation in turn paved the way for mutual respect and sharing of ideas.

Despite difficulties in implementation, retorts can be an appropriate technology for mercury mitigation in Ghana when miners are involved in their design. We began by co-defining the problem and goal with our partners, and allowed for complete collaboration in every step of our design process. In doing so, miners understood our intentions and were willing to hear our expertise as engineers, just as we were willing to hear their expertise as miners. Although the first prototype did not fulfill all of the design requirements we outlined, it allowed the miner to take the lead in the design process and created a baseline for future iterations that would incorporate greater health and environmental safety. After the initial iteration, our subsequent designs incorporated an additional condensation feature that addressed the health concerns that the miners were most passionate about improving.

While we still await extensive technical performance testing, our team is aware that the mercury reclamation rate of our device may be less compared to other examples of retorts designed for ASM. What makes this device unique, however, was the miners involvement in the co-design process. They brought their own concerns and design criterias forward, and for this reason, created a design that differs from other retorts. Although health, as opposed to mercury reclamation, was at the forefront of their design criteria, a device was still created that will mitigate some environmental pollution due to mercury, even if it is less than some conventional designs. This co-

creation will also encourage the use of the device by the miners; they have ownership of the solutions produced and are more willing to integrate them into their practices. Therefore, it may become necessary to sacrifice technical performance for the sake of pragmatism. Of course, a balance must be found, but it must be reached through the mutual respect and shared understanding established from the outset.

We hope this device can eventually be implemented into the larger community. Like the design process, this implementation scheme must involve the miners themselves, as they are the best ones to disseminate their own ideas. Miners have ethos in explaining the operation and purpose of proposed solutions to their fellow miners in the way that a foreigner or even higher-ranking Ghanaian could never reach. This further emphasizes the necessity of involving local experts throughout the co-creation process.

Lastly, we have learned lessons from co-design about our own perspectives as technical experts. In our first meeting with the miners, one said he didn't like scientists, because "scientists need proof to believe things" and are unwilling to accept claims without evidence. As engineers, we overcame this original notion by having trust in the experiential expertise of our local partners. Overall, just as our collaboration has produced designs for increased mercury health and environmental safety, it has caused our own preconceived notions and perceptions to be redesigned. In our own future work, these attitudes and values prepare us to make solutions tailored to the people that will use them.

REFERENCES

- Amankwah, R. K. (2014). A Lantern Retort for Small-Scale Gold Extraction. *International Journal of Environmental Protection and Policy*, 2(5), 161. doi: 10.11648/j.ijjepp.20140205.13
- Amankwah, R., Adjei, D., & Ofori-Sarpong, G. (2017). Preprint 17-018 Breaking The Wall of ASM Mercury Pollution: The Lantern Retorty
- Amponsah-Tawiah, K. & Dartey-Baah, K. (July 2011). "The Mining Industry in Ghana: A Blessing or a Curse." Centre for Promoting Ideas *International Journal of Business and Social Science*. Retrieved from http://ijbssnet.com/journals/Vol._2_No._12%3B_July_2011/8.pdf
- Appel, P.W.U. and Na-Oy, L.D. (2014). Mercury-Free Gold Extraction Using Borax for Small-Scale Gold Miners. *Journal of Environmental Protection*, 5, 493-499. <http://dx.doi.org/10.4236/jep.2014.56052>
- Bebbington, Anthony et al. (2018). *Governing Extractive Industries*. Oxford, United Kingdom: Oxford University Press.
- Botchwey, G & Gordon C. (November 2019). "Lifting the lid on Ghana's illegal small-scale mining problem" *The Conversation*. Retrieved from <https://theconversation.com/lifting-the-lid-on-ghanas-illegal-small-scale-mining-problem-123292>
- Bradbury, J. H., Cliff, J., & Banea, J. P. (2015). "Making cassava flour safe using the wetting method". *South Sudan Medical Journal*, 8(1). 4-7.
- Breaux, J. H. (2014, December 23). Argonne/EPA system captures mercury from air in gold shops. Retrieved from <https://phys.org/news/2014-12-argonneepa-captures-mercury-air-gold.html>
- Driscoll, Charles T. et al. (2013). "Mercury as a Global Pollutant: Sources, Pathways, and Effects." *Environ Sci Technology*. Retrieved from <https://www.ncbi.nlm.nih.gov/pmc/articles/PMC3701261/>
- Duke University. (2009). "How Mercury Becomes Toxic In The Environment." *ScienceDaily*. Retrieved from <https://www.sciencedaily.com/releases/2009/08/090818150020.htm>
- Fisher Scientific. (2019). Safety Data Sheet Mercury. Retrieved from <https://fscimage.fishersci.com/msds/96252.htm>.

- Geenen, Sara. (2016). *African Artisanal Mining from the Inside Out: Access, norms, and power in Congo's gold sector*. New York, New York: Routledge.
- Hilson, G., Hilson, C. J., & Pardie, S. (2007). Improving awareness of mercury pollution in small-scale gold mining communities: Challenges and ways forward in rural Ghana. *Environmental Research*, 103(2), 275–287. doi: 10.1016/j.envres.2006.09.010
- Hong, Young-Seoub et al. (2012). “Methylmercury Exposure and Health Effects.” *J Prev Med Public Health*. Retrieved from <https://www.ncbi.nlm.nih.gov/pmc/articles/PMC3514465/>
- Hylander, L. D., Plath, D., Miranda, C. R., Lücke, S., Öhlander, J., & Rivera, A. T. (2007). Comparison of different gold recovery methods with regard to pollution control and efficiency. *CLEAN–Soil, Air, Water*, 35(1), 52-61.
- Jønsson, J. B., Appel, P. W., & Chibunda, R. T. (2009). A matter of approach: the retorts potential to reduce mercury consumption within small-scale gold mining settlements in Tanzania. *Journal of Cleaner Production*, 17(1), 77–86. doi: 10.1016/j.jclepro.2008.04.002
- Kevane, M. (2015). Gold Mining and Economic and Social Change in West Africa. In C. Monga & J. Y. Lins. (Eds.), *The Oxford Handbook of Africa and Economics: Volume 2: Policies and Practices*, Oxford University Press. Retrieved from <https://scholarcommons.scu.edu/cgi/viewcontent.cgi?article=1069&context=econ>
- Mannik L. & McGarry K. (2017). “Practicing Ethnography: A Student Guide to Method and Methodology.” Toronto, Canada: University of Toronto
- Mercury (Elemental): Lung Damaging Agent. (2011). The National Institute for Occupational Safety and Health. Retrieved from https://www.cdc.gov/niosh/ershdb/emergencyresponsecard_29750021.html
- McQuilken, James and Hilson, Gavin. (August 2016). “Artisanal and small-scale mining in Ghana: Evidence to form an ‘action dialogue.’” IIED. Retrieved from <https://pubs.iied.org/pdfs/16618IIED.pdf>
- Murcott, Susan. (2007). “Co-evolutionary design for development: Influences shaping engineering design and implementation in Nepal and the global village.” *Journal of International Development*. Retrieved from www.interscience.wiley.com
- Nyamunda, B. C. (2017). Review of the Impact on Water Quality and Treatment Options

of Cyanide Used in Gold Ore Processing. *Water Quality*. doi: 10.5772/65706

Parsons, L. B. (1996). Engineering in Context: Engineering in Developing Countries. *Journal of Professional Issues in Engineering Education and Practice*, 122(4), 170–176. doi: [https://doi.org/10.1061/\(ASCE\)1052-3928\(1996\)122:4\(170\)](https://doi.org/10.1061/(ASCE)1052-3928(1996)122:4(170))

Peter W.U. Appel, PhD¹; Leoncio Na-Oy² (2012) The Borax Method of Gold Extraction for Small-Scale Miners Blacksmith Institute Journal of Health & Pollution Vol. 2, No. 3

Tschakert, P., & Singha, K. (2007). Contaminated identities: Mercury and marginalization in Ghana's artisanal mining sector. *Geoforum*, 38(6), 1304–1321. doi: 10.1016/j.geoforum.2007.05.002

Tsikata, F. S. (1997). “The vicissitudes of mineral policy in Ghana”, *Resource Policy*, 23, 9-14

United Nations Development Program. (August 2018). “Minimata Convention on Mercury Initial Assessment Report for Ghana” Retrieved from https://www.undp.org/content/dam/ghana/docs/Reports/UNDP_GH_SDC_MIA_REPORT_2018-1.pdf

United Nations Environmental Programme. (2012). “A Practical Guide: Reducing Mercury Use in Artisanal and Small-Scale Gold Mining”. Retrieved from https://wedocs.unep.org/bitstream/handle/20.500.11822/11524/reducing_mercury_artisanal_gold_mining.pdf?sequence=1&isAllowed=y

United Nations Environmental Programme. (2018). “Global Mercury Assessment”. Retrieved from <https://wedocs.unep.org/bitstream/handle/20.500.11822/27579/GMA2018.pdf?sequence=1&isAllowed=y>

World Health Organization. (2016). “Artisanal and small-scale gold mining and health”. Retrieved from <https://apps.who.int/iris/handle/10665/247195>.

APPENDICES

Appendix A: Agendas for Inactive and Active Mine Visits

Appendix B: Agendas for Workshops

Appendix C: Device Questionnaires for Miners

Appendix D: Operations Safety & Maintenance Manual

Appendix E: Structural Failure Analysis

Appendix F: Final Design Specifications and Technical Drawings