

Project Number: MQP MTP - 0002

**Consideration of an Exterior Water Spray System for the Protection  
of Residential Structures from the Impingement of Firebrands  
During a Wildfire Event**

A Major Qualifying Project Report

Submitted to the Faculty of

WORCESTER POLYTECHNIC INSTITUTE

In partial fulfillment of the requirements for the

Degree of Bachelor of Science

By:

Shannon Alvarez

Mitchell Pastizzo

Date:

March 22, 2019

Approved By:

Milosh T. Puchovsky

Albert Simeoni

## Table of Contents

Executive Summary .....	5
Abstract .....	7
Acknowledgements .....	8
List of Figures .....	9
List of Tables .....	10
List of Abbreviations and Acronyms .....	10
1 Introduction .....	11
1.1 Problem Statement .....	11
1.2 Organization of Report .....	12
1.3 The Problem of Wildfires .....	13
1.4 Wildfire Prevention Stakeholders .....	14
2 Background .....	17
2.1 The Physics of Wildfires .....	17
2.1.1 Fuel .....	17
2.1.2 Wind .....	17
2.1.3 Heat Transfer .....	17
2.1.4 Smoldering .....	18
2.2 How Wildfires Spread .....	19
2.2.1 Wildland Firefighting Methodology .....	19
2.2.2 Building Construction Materials .....	20
2.3 Structural Vulnerabilities .....	20
2.3.1 Deck .....	20
2.3.2 Roof .....	21
2.3.3 Siding .....	23
2.3.4 Structural/Compartment Firefighting Methodology .....	23
2.4 Firebrands .....	24
2.4.1 Firebrand Production .....	24
2.4.2 Spotting Distance .....	25
2.4.3 Limiting Fires from Firebrands in Residential Structures .....	25
2.5 Fire Suppression Systems .....	26

2.6 Existing Designs.....	27
2.6.1 Existing Patents .....	28
2.6.2 Spray Safe.....	30
3. Methodology.....	32
4 Project Scope, Goals, Objectives, and Performance Criteria.....	35
4.1 Project Scope.....	35
4.2 Project Goals .....	35
4.3 Project Objectives .....	35
4.3.1 Detect fire .....	35
4.3.2 Activate System.....	35
4.3.3 Apply Appropriate Water .....	35
4.4 Performance Criteria .....	35
4.4.1 Assumptions .....	35
4.4.2 Mass Flux .....	36
4.4.3 Flame Height .....	36
4.4.4 Water Supply .....	37
5 Fire Scenarios.....	38
5.1 Number of Firebrands Attacking Structure.....	38
5.2 The House .....	41
5.3 Trees .....	43
6 Simulation of Accumulation of Firebrands.....	44
6.1 Simulating the FDS Scenario .....	44
6.1.1 FDS Background .....	44
6.1.2 Detailed Properties of Solid Particles.....	45
6.1.8 Creating Obstructions in FDS.....	45
6.1.3 Wind in FDS.....	46
6.2 Firebrands in FDS .....	47
6.3 The House in FDS.....	50
6.4 Overview of Fire Scenario .....	52
6.4.1 Water Spray in FDS.....	57
7 System Design .....	59
7.1 Detection .....	59

7.2 Water Spray Discharge Requirements .....	61
7.3 Water Spray Nozzle Selection.....	62
7.3.1 Trial Design 1: Viking Spray Nozzle VK810 .....	63
7.3.1 Trial Design 2: Reliable Model R20-80 .....	64
7.3.3: Other System Components .....	66
8 Evaluating Trial System Design .....	69
9 Recommendations for Future Work.....	71
10 Conclusion .....	73
Bibliography .....	74
Appendix A: Structural Losses by Wildfire as Reported by the NIFC.....	80
Appendix B: FDS Source Code .....	82
Appendix C: Component Data Sheets .....	82
Appendix D: System Design and Hydraulic Calculations .....	82
Appendix E: Project Methodology .....	83

## Executive Summary

In 2018, millions of acres of land burned as a result of wildfire<sup>1</sup>. Even more alarming, around 1500 structures are lost per year to wildfires<sup>2</sup>. Among these losses, residential homes on the Wildlife-Urban Interface (WUI) stand out as vulnerable structures. As seen by recent events, such as the Camp Fire, large scale wildfire events are a reality of today<sup>3</sup>. Burning embers, called firebrands, are lofted into the air during a wildfire and land on vacated structures, igniting them. The purpose of this project is to investigate the fire threat from firebrands on residential structures and propose an exterior fire protection system design that could improve the survivability of the structure.

As a means of organizing and completing the project, the framework outlined in the *SFPE Engineering Guide to Performance-Based Design* was utilized. The associated process provides a workflow that can be applied to a wide range of fire protection engineering design problems. Specific project goals were articulated through a series of objectives and acceptance criteria. A trial system design was developed and evaluated for a specific wildfire scenario involving firebrands as the ignition source. Key assumptions and numerical models were applied in the development of the wildfire scenarios, and in the evaluation of the proposed fire protection system which consisted of a water spray system automatically activated by radiant energy fire detectors.

Wildfire planning, prevention, response, and firefighting remain areas of active research. This project focuses on an active exterior residential suppression system for which there is less research and fewer commercially available systems. While wildfire flame front firefighting techniques have been developed, less confidence exists with the phenomena associated with firebrand production, transport, accumulation, detection and suppression. Wildfire behavior is influenced by wind, which also affects firebrand transport and accumulation. The effects of weather, and the transport and accumulation of firebrands was investigated to better understand ignition phenomena of the dwelling and resulting fire growth.

The scenarios addressed considered a dwelling of typical combustible construction exposed to an assault of fire brands over a specified time duration. Firebrands would accumulate adjacent to the structure, along an exterior deck, causing ignition and flaming combustion on the exterior surface. The goal of the fire protection system is to activate at an appropriate time, and discharge a sufficient amount of water over a desired surface area for a specified time period, limiting damage so that the structure could be usable after the incident. While a number of areas of a dwelling such as roofs, eaves, corners, and gutters are especially susceptible to firebrand ignition, this study focused on the accumulation of firebrands and resulting fire at the intersection of an exterior wall and an attached wooden deck.

Firebrand transport and accumulation were approximated using NIST's Fire Dynamics Simulator (FDS), a computational fluid dynamics (CFD) model of fire driven fluid flow. While FDS was not designed for this specific application, it provided some insight of firebrand

---

<sup>1</sup> Facts + Statistics: Wildfires, (2018)

<sup>2</sup> Center, (2016)

<sup>3</sup> McWhirter, *Deadliest Fire in California History Deemed Contained*, (2018)

transport, accumulation and resulting ignition of the structure. In particular, firebrand transport was modeled to some level of satisfaction. Firebrand accumulation and ignition were more difficult to approximate.

Means of fire detection, system activation, discharge criteria and water supply duration were studied, and system components were specified. A specific objective of the fire protection system was to activate in a timely and reliable manner to control flaming combustion until the threat of firebrand ignition was significantly reduced. An exterior ultraviolet radiant energy detector was specified as means of detecting flaming combustion. Upon activation, the system discharges water in a specified manner from water spray nozzles located at the eaves of the roof and positioned so as to direct discharge down the sides of the exterior wall and adjacent deck. Water supply was found to be a critical limitation in system effectiveness

Recommendations for future work into the complicated problem of firebrand suppression in the WUI were made. One of the key areas for future work is research into maximum firebrand rates of accumulation on a surface. Most of the in-field firebrand research was based after large wildfires had already passed through a community or for low to medium intensity prescribed burns. In order for more accurate data to be gathered, embers must be studied in-situ and in real time. Further future work includes understanding the insulating effect of firebrand piles, water spray penetration, and adding more capability to modeling particles in FDS. Additional research is also needed in detection of firebrand attacks, system activation, discharge criteria, and availability of water supply.

## Abstract

Wildfires are destroying millions of acres of forest yearly, putting residential homes and commercial buildings at risk as individuals continue to settle in the Wildland Urban Interface (WUI). This project utilized a Performance-Based Design approach to develop and evaluate an exterior water spray system for improving the survivability of a residential structure from a firebrand exposure during a wildfire event. A fire scenario was developed to quantify the wildfire threat and study the impact of firebrands on residential structures. Firebrand transport and accumulation were mathematically modeled using Fire Dynamics Simulator (FDS). A water spray system was developed to meet specific goals for the scenario defined. The system was designed so that the average homeowner could purchase commercially available components and have the system installed. The proposed system includes ultraviolet radiant energy detectors to detect flaming combustion in an outdoor environment. Upon activation, the water spray system discharges water down the sides of the exterior wall and onto the adjacent deck. The design includes an external water source consisting of a tank and pump to supply the system with the necessary water flow. Recommendations for future work include real-time data collection of firebrand accumulation, improvements for detection, understanding of water spray in exterior wind-driven environment, and refinements to FDS for use in assessing firebrand transport and accumulation.

## Acknowledgements

Thank you to our project advisor Professor Milosh Puchovsky and co-advisor Albert Simeoni for their guidance throughout the project. We would also like to acknowledge the Fire Protection Engineering Department, Mechanical Engineering Department, and the Civil Engineering Department for their support of the project. We would also like to thank Dr. Spencer in the WPI Academic & Research Computing group for providing computational support that contributed to the results reported within this paper. A special thank you to Marcio Mendes, an FPE graduate student for all his help, especially with water spray nozzle selection and system design. His knowledge and expertise were incredibly valuable to the team.



## List of Figures

Figure 1: Average Structural Losses by Number of Buildings .....	14
Figure 2: Stakeholders in Wildfire , , , .....	15
Figure 3: Redwood decking ignition by firebrand showers.....	21
Figure 4: Burning pine needle mulch (center) and bark mulch (left). Pine needle debris next to the roof dormer also ignited.....	21
Figure 5: Damage to the roof covering after ignition of the pine needle debris in the valley. ....	22
Figure 6: Firebrands accumulating near the roof dormer .....	22
Figure 7: Flaming ignition of firebrands causing vinyl siding to melt .....	23
Figure 8: Sketch of System Design.....	29
Figure 9: Sketch of System Design.....	29
Figure 10: Sprinkler system layout and visual of water film covering siding of house .....	30
Figure 11: Spraysafe Protecting Parts of the Structure Firefighters Cannot Reach.....	31
Figure 12: SFPE Performance-Based Design Process.....	32
Figure 13: Heat transfer from a pile of firebrands and a single firebrand .....	39
Figure 14: Heat flux under forced flow and ambient conditions .....	39
Figure 15: Visual IR images captured for 1,10 and 15 minutes .....	40
Figure 16: Thermocouples and thin skin calorimeters averaged over a 10g pile of firebrands....	41
Figure 17: Revit Rendering of Design House and Surrounding Property .....	42
Figure 18: Wildfires in California.....	42
Figure 19: Pinus ponderosa.....	43
Figure 20: Capture of the FDS Run of the NIST Dragon .....	50
Figure 21: Capture of the FDS Run of the NIST Dragon with House.....	53
Figure 22: Capture of the FDS Run with Firebrand Particle Cloud .....	54
Figure 23: Capture of the FDS Input Profile for the Entire House .....	55
Figure 24: Capture of the FDS Input Profile for the Entire House, Top View.....	55
Figure 25: Capture of the FDS Results for the Entire House .....	55
Figure 26: Capture of the FDS Results with Wind Profile .....	56
Figure 27: Test of Large Particle Accumulation.....	56
Figure 28: Capture of the FDS Results for Small Design Area.....	57
Figure 29: TAKEX America’s FS-2000E flame detector.....	60
Figure 30: Layout of Detectors .....	61
Figure 31: House Isometric and Top View in CAD. ....	63
Figure 32: Viking System Design.....	64
Figure 33: Hydraulic Calculations .....	64
Figure 34: Reliable Sprinkler Trial Design.....	65
Figure 35: Reliable System Design.....	65
Figure 36: Reliable Water Spray System Calculations.....	66
Figure 37: Plastic Potable Water Storage Tank and 3.5 HP Gas Powered Pump.....	67
Figure 38: 2" Electronic Solenoid Valve .....	68
Figure 39: An Example Clevis Hanger .....	68

Figure 40: System Fault Tree.....	70
Figure 41: 2016 Structural Losses by Number of Buildings .....	80
Figure 42: 2017 Structural Losses by Number of Buildings .....	81

## List of Tables

Table 1: Compendium of Firebrand Research .....	25
Table 2: FDS Material Properties .....	52
Table 3: 2016 Structural Losses by Wildfire .....	80
Table 4: 2017 Structural Losses by Wildfire .....	80

## List of Abbreviations and Acronyms

<b>Abbreviation or Acronym</b>	<b>Description</b>
ASTM	American Society for Testing and Materials
BIA	Bureau of Indian Affairs
BLM	Bureau of Land Management
CAD	Computer-Aided Design
CALFIRE	California Department of Forestry and Fire Protection
CFD	Computational Fluid Dynamics
DOD	Department of Defense
FDS	Fire Dynamics Simulator
HRR	Heat Release Rate
IBHS	Institute for Business and Home Safety
IR	Infrared
NASF	National Associate of State Foresters
NFPA	National Fire Protection Agency
NICC	National Interagency Coordination Center
NIST	National Institute of Standards and Technology
NPS	US National Park Service
SFPE	Society of Fire Protection Engineers
UL	Underwriters Laboratories
USFA	US Fire Administration
USFS	US Forest Service
USFWS	US Fire and Wildlife Service
UV	Ultraviolet
WEEDS	Wind-Enabled Ember Dousing System
WUI	Wildlife-Urban Interface

# 1 Introduction

## 1.1 Problem Statement

The intent of this project is to minimize residential property losses in the wildlife-urban interface (WUI). By the numbers, thousands of households have burned in the past year and thousands more are in identified zones that have the potential to. Currently, this force of nature is already fought through practices in place by forestry management in the US by the US Forest Service, in addition to state and local fire services. Instances exist where municipalities have pre-planned their responses to wildfire incidents. There are also recommendations in place for communities and individuals, emphasizing the creation of a defensive space around a home, such as 30 ft brush-free perimeter. At the individual level, there are case studies of neighborhoods and individuals preventing wildfire from destroying their home with irrigation sprinklers<sup>4</sup>. Portable suppression trailers and private wildfire companies offer individual solutions to protecting their home. However, most of these solutions do not seem to be supported by an abundance of real-world data (i.e. actually being employed against the direct threat of a wildfire) or test data exemplifying system effectiveness. As reported in the *Wall Street Journal*, the problem of the temperature of the Earth gradually increasing with climate change, is causing drastic changes in the behavior of natural disasters<sup>5</sup>. As a result, insurance companies are increasing yearly premiums to account for the increased uncertainty. Equipping residential properties with an external water spray system to protect against wildfires has the potential to reduce the devastating effects of the increasing severity of wildfires and has the potential to save properties for homeowners and insurers.

The goal of this MQP is to create an effective wildfire fire protection system which defends against firebrands for a residential property by grounding our system design in mathematics and fire dynamics. A design fire or series of design fires under established criteria will be used to develop an appropriate system or series of recommendations.

---

<sup>4</sup> Johnson, *External Sprinkler Systems and Defensible Space: Lessons Learned from the Ham Lake Fire and the Gunflint Trail*, (Minnesota, 2008)

<sup>5</sup> Hope, *Climate Change is Forcing the Industry to Recalculate* (New York, 2018)

## 1.2 Organization of Report

This report is organized into ten chapters, which are as follows:

Chapter 1 introduces the problem and outlines the overall approach used.

Chapter 2 provides a background about wildfires, firebrands, and relevant fire protection system information

Chapter 3 outlines the methodology for how the team approached the problem.

Chapter 4 details project scope, goals, objectives, and performance criteria.

Chapter 5 provides relevant fire scenarios for the problem.

Chapter 6 contains appropriate FDS details and analysis of our design scenario.

Chapter 7 highlights trial designs, which include system activation, suppression, and water supply.

Chapter 8 evaluates trial designs and results of system performance for our given fire scenario.

Chapter 9 is a discussion of results and recommendations for future work.

Chapter 10 is a summary of our report and application to the problem of wildfires overall.

### 1.3 The Problem of Wildfires

The problem of wildfires is one of international attention. Over the past few years, wildfires have caused billions of dollars in property damage<sup>6</sup>. As seen in the most recent catastrophic wildfires, such as the Fort McMurray and Camp fires, parts of the world that believed that wildfire risk to homes in the area was non-existent are experiencing devastating wildfires leaving insurance companies with billions in damages. Wildfires are destroying millions of acres of forest yearly, putting residential homes and commercial buildings at risk as individuals continue to settle in the WUI. The vegetation in undeveloped grasslands and forests, when combined with topography and weather, determine the intensity and speed that the fire can spread.

The Insurance Information Institute estimates that in 2018 alone, 5.1 million acres have burned due to wildfire from January to August<sup>7</sup>. The amount lost per year from the disruptions wildfires is clearly not insignificant. Even more concerning is the impact of wildfire on the structures and infrastructure of the US. In November of 2018, it was reported that up to 19,000 structures burned around Paradise, California, as a result of the Camp Fire<sup>8</sup>.

At this point, no single national database tracks structural damage to homes from a wildfire. However, the National Interagency Coordination Center (NICC) tracks wildfire damage data from forms filled out by wildfire dispatch centers. Statistics for 2016 and 2017 are broken down in Appendix A. The NICC reports state “a total of 4,312 structures were destroyed by wildfires in 2016, including 3,192 residences, 1,025 minor structures, 78 commercial structures and 17 mixed commercial/residential structures”<sup>9</sup>. In 2017, a total of 12,306 structures were destroyed by wildfires, including 8,065 residences, 4,002 minor structures, 229 commercial structures and 10 mixed commercial/residential structures<sup>10</sup>. Since 1999, the NICC has reported an average of 1,449 residences, 1,248 minor structures, and 53 commercial structures destroyed by wildfire, with this year ranking 5th in total structures lost. Figure 1, is the 10-year average for lost structures. No data has been released as of this publication for the 2018 calendar year. These statistics were acquired through aggregated 911 dispatch center data.

---

<sup>6</sup> *Largest Loss Wildland Fires*, (2018)

<sup>7</sup> *Facts + Statistics: Wildfires*, (2018)

<sup>8</sup> McWhirter, *Deadliest Fire in California History Deemed Contained*, (2018)

<sup>9</sup> Center, *Wildland Fire Summary and Statistics Annual Report*, (2016)

<sup>10</sup> *Ibid.*

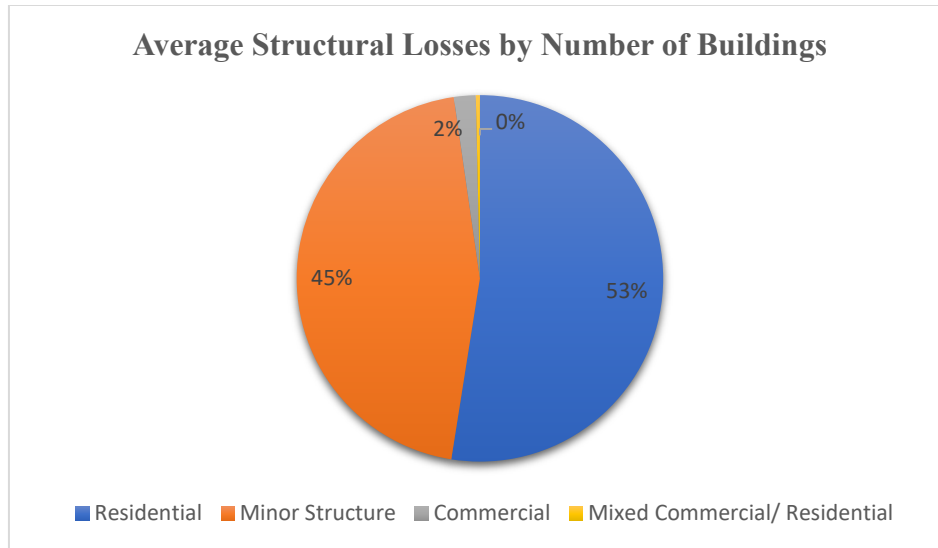


Figure 1: Average Structural Losses by Number of Buildings <sup>11</sup>

All the known property loss data indicates that residential structures being the largest group structure group being destroyed by wildfire today. NIST estimates that the cost per destroyed structure is approximately \$143,094 in 2016 dollars<sup>12</sup>. With 1449 residences destroyed, which were tracked by the NICC, an average of 207 million dollars of residential property is lost per year to wildfires. The calculated cost per destroyed structure is likely to be conservative, because it does not take into consideration the lost opportunity cost from the loss of a home, which makes the calculated cost potentially even more expensive. With such large losses every year, an opportunity exists to prevent residential structures being lost to wildfire. Even minor structures such as sheds, free standing garages, and outbuildings represent a large portion of the structures at risk. These structures are enclosed, free standing, non-habitable structures that are detached from a dwelling. They are used for storage of domestic items such as gardening/ hobby equipment, vehicles, and other materials<sup>13</sup>. More research into targeting minor structures for fire suppression may be needed in the future. However, the concern today is to limit the loss of high value properties such as primary residences. The problem of wildfires places residential structures at the greatest risk.

#### 1.4 Wildfire Prevention Stakeholders

From brushfires in Australia, to large forest fires in British Columbia, it is not feasible to try and prevent the hazard of wildfires from occurring at all, in the same way that other large-scale natural disasters are not totally preventable. However, the risks can be controlled.

At the macro level, various countries employ national wildfire agencies to mitigate the disaster. They have been known to share resources such as aircraft and manpower across

<sup>11</sup> Ibid.

<sup>12</sup> Thomas, Butry, Gilbert, Webb, Fung, *The Costs and Losses of Wildfires*, (2017)

<sup>13</sup> *Sheds, Free Standing Garages & Outbuildings*, (Mandurah, 2018)

borders<sup>14</sup>. The U.S. alone spent upwards of \$3 billion on federal firefighting costs in 2017<sup>15</sup>. Wildfires are a deadly and resource intensive phenomenon requiring massive amounts of money dedicated towards fighting wildfires when they do occur. However, the challenge increases when these fires burn within the proximity of developed areas. This zone is known as the Wildlife Urban Interface, or WUI. When the large-scale tactics of national and state level firefighting meet the structures of towns and communities, the picture becomes complicated. Drawing and maintaining a boundary line between allowable forest acres consumed by wildfire and residential property lines is incredibly difficult, especially considering the most intense wildfires do not occur by chance alone. Wildfires often occur after weeks of drought affects the fuel moisture content in vegetation and generally lowers the supply of available water to combat the fire. Furthermore, wind is often a driving factor in wildfire growth and behavior. The problem of combating wildfires in the WUI occurs across the United States, the WUI covers 719,156 km<sup>2</sup> (9.4% of the land area) and contains 38.5% of all housing units<sup>16</sup>. Figure 2 highlights some of the stakeholders invested in preventing and managing wildfires in the US.



Figure 2: Stakeholders in Wildfire<sup>17, 18, 19, 20, 21</sup>

<sup>14</sup> Center, *Wildland Fire Summary and Statistics Annual Report*, (2016)

<sup>15</sup> *Federal Firefighting Costs (Suppression Only)*, (2017)

<sup>16</sup> Radeloff, *The Wildland Urban Interface in the United States*, (2005)

<sup>17</sup> Dan Smith, *National Multi-Agency Coordinating Group Operations Plan*, (2018)

<sup>18</sup> *Wildland Fire Management - Agencies and Their Roles*

<sup>19</sup> *Member Agencies Contacts*

<sup>20</sup> *Marin County Community Wildfire Protection Plan*, (2016)

<sup>21</sup> *Your California Fire Information Center*, (2018)

What is not widely understood is that some national wildfire fighting organizations do not have an interest in individual structural protection. The USDA Forest Service Wildland Fire and Aviation Program’s bylaws specifically state “The Forest Service shall not:

(a) Take direct suppression actions on structures other than those that tactically reduce the threat of fire spread to them.

(b) Enter structures or work on roofs of structures for the purpose of direct suppression actions”<sup>22</sup>.

To organizations focusing on containing the wildfire at large, individual structure losses are merely collateral. Their purpose and mission are different than that of the individual homeowner.

Previous studies have shown that in order to protect the interests of residential stakeholders, there are a series of best-practices that government organizations are beginning to enforce<sup>23</sup>. After the 2009 Victorian Brushfire, which killed 173 people and destroyed 2029 houses, several recommendations were made by the Royal Commission in Australia. Beyond creating national wildfire prevention groups, the focus for regional stakeholders and below on the hierarchy was the defense of homes in extreme conditions<sup>24</sup>.

For years, government agencies, interest groups, and insurance companies have made criteria for how to best protect residential structures. The Institute for Business and Home Safety (IBHS) published a report titled *Mega Fires: The Case for Mitigation*, which analyzed the Witch Creek Fire in California of 2007<sup>25</sup>. It claimed that there are eight key factors affecting wildfire risks to buildings, with the flammability of the roof as a major concern. The study cites falling embers, known as firebrands, as a threat to roofs of structures. The second key area was areas of a building where firebrands frequently accumulate, such as gutters, edges and valleys of roofs, intersections between a deck and wall, or inside corners of a house. The third area is any pathway which allows burning embers to get inside a house, such as soffits, crawl spaces, or wall vents. The next four factors encompassed fuel sources that would bring flame within 5 to 10 feet of a house. This includes foliage, plants, wood structures, large trees, a large nearby canopy of trees, and nearby firewood. The final factor which created risk for homes in a wildfire was firefighter access to the property<sup>26</sup>.

The goal of national and municipal fire services is to combat the flame front in order to limit the fire. By limiting the front of the wildfire, the four fuel source threats can be mitigated with additional input by homeowners following certain recommendations for brush management. However, the threat of firebrands still exists to homes. In order to understand this specific threat, the total cycle of wildfires must first be examined.

---

<sup>22</sup> Jaelith Hall-Rivera, *Wildland Fire Management*, (Washington, DC, 2018)

<sup>23</sup> Teague, *2009 Victorian Brushfires Royal Commission*.

<sup>24</sup> Ibid.

<sup>25</sup> *MEGA FIRES: The Case for Mitigation*, (2017)

<sup>26</sup> Ibid.



## 2 Background

### 2.1 The Physics of Wildfires

#### 2.1.1 Fuel

Vegetation and structures are the main sources of fuel for wildfires. The vegetation can range from trees, underbrush, grassy fields, and structures includes residential buildings, businesses, sheds, etc. The type of vegetation available and its characteristics play a significant role in how the fire burns. If the fire is in a forest of large, dense trees, the trees will produce heat and burn for a long time. Dried grass and leaves would result in a fire that burns rapidly and does not generate a lot of heat<sup>27</sup>. Comparatively, vegetation, especially dry vegetation, does not require a large amount of heat to ignite, therefore common ignition sources such as a match or cigarette are enough to cause the vegetation to catch fire.

#### 2.1.2 Wind

Wind moves more rapidly up slopes, which increases the speed that the fire spreads at. Wind not only spreads the fire by moving it along landscapes, it also acts as a source of oxygen flow, allowing the fire to grow much more rapidly.

#### 2.1.3 Heat Transfer

Radiative heat transfer plays a major role in the spread of forest fires. Radiation is the movement of heat through space as short energy waves. Heat radiating from the wildfire fronts warms the air and preheats any flammable fuel which causes it to ignite more rapidly when the flames arrive. The infrared rays are also known to preheat the fuel to their ignition point which also causes the fire to spread more quickly. Intermittent heating, when the flame-front approaches the surface of fine particles intermittently heating them to about 100 degrees Celsius until reaching ignition temperature, is a specific example of how radiation is significant in the growth of forest fires<sup>28</sup>.

Convection contributes to the spread of wild fires when the heat from the fire flows in a current from hotter air to cooler air. The gases generated by the wildfire creates convection columns which carry firebrands, hot wooden embers, over any breaks in the fire, such as roads or rivers, and can accumulate and cause spot fires. The vorticity forces created from convection pushes the flames downward into the fuel bed which causes the fire to travel towards the fresh fuel. Repetitive convective heating is thought to be the critical heat transfer method in wildfire spread<sup>29</sup>.

Conductive heat transfer, which is the transmission of heat within the material itself, was originally considered insignificant in the spread of wildfires. However, after recent research, it has been found that conduction plays an important role in the spread of large forest fires in the form of firebrands or hot wooden embers. Conduction helps spread wildfires by carrying the

---

<sup>27</sup> *Fire Ignition, Behavior & Effects*, (2019)

<sup>28</sup> Finney, *Proceedings of the National Academy of Sciences of the United States of America*, (2015)

<sup>29</sup> Ibid.

flames through the air over any firebreaks such as roads or rivers. Firebrands ignite any dry ground or trees that are downwind from the fire<sup>30</sup>.

#### 2.1.4 Smoldering

Smoldering is a form of combustion that burns slowly without a flame, at a low temperature. The heat that develops when oxygen directly attacks the surface of a condensed fuel helps sustain smoldering combustion. Smoldering is dangerous because it can provide a pathway to flaming combustion that can be started by sources of heat that would normally be too weak to cause a flame<sup>31</sup>. Thus, the smoldering firebrands attacking the house and accumulating are a threat to the house because the heat accumulated can cause the firebrands to transition to flaming combustion and cause damage to the house.

##### 2.1.4.1 Experimental Data

Glowing combustion has been observed to reach critical heat flux values as low as 8 kW/m<sup>2</sup>, however it was not sustained without an external heat flux<sup>32</sup>. The smoldering combustion in a study was found to have a peak temperature between 500 and 700 C and a heat of combustion in the range of 6-12 kJ/g, compared to flaming combustion which has a peak temperature range of 1500-1800 C and a heat of combustion of 16-30 kJ/g. It was also observed that with smoldering combustion there was a higher surface temperature when there was a higher wind velocity.

##### 2.1.4.2 Smoldering Kinetics

Since the firebrands attacking the structure in this project are both flaming and smoldering, it is important to understand the kinetics of smoldering combustion to design a system to protect the structure. The chemical kinetic representation of smoldering combustion is very close to that of the pyrolysis of materials<sup>33</sup>. There is difficulty in quantifying exactly how the reaction would occur without experimental results to compare. Smoldering has a higher conversion of fuel to toxic gases than flaming combustion, however it occurs at a lower rate<sup>34</sup>. The pathway to flaming is too weak to produce a flame and when it degrades a char is formed.

In a study done by Krause and Schmidt that used a series of organic powder samples (cork, beech, and cocoa) it was also observed that there was a decrease in the critical temperature with ember size. They reported that the transition to flaming occurred at temperatures from 950-1000K and reported a minimum temperature of 400 C for smoldering ignition<sup>35</sup>. Thus, the accumulation of smoldering firebrands near a house can transition to flaming combustion at

---

<sup>30</sup> *Fire Ignition, Behavior & Effects*, (2019)

<sup>31</sup> T.J. Ohlemiller, *Smoldering Combustion*, (Gaithersburg, MD, 1986)

<sup>32</sup> Douglas Drysdale, *An Introduction to Fire Dynamics*, (2011)

<sup>33</sup> Douglas Drysdale, *SFPE Handbook*, (2016)

<sup>34</sup> T.J. Ohlemiller, *Smoldering Combustion*, (Gaithersburg, MD, 1986)

<sup>35</sup> Ibid

significantly lower temperature than if the house were to catch fire from the heat of the wildfire alone.

A study by Moussa in 1977<sup>36</sup>, divided that propagation of smoldering along cylindrical cellulosic elements into three distinct zones. The first zone is a pyrolysis zone where there is a steep rise in temperature and an outflow of visible airborne products from the original material. The second zone is where the maximum temperature is reached, and the evolution of the visible product stops and transitions to glowing. Finally, the third zone is no longer glowing consists of a porous residual char where the temperature is decreasing.

## 2.2 How Wildfires Spread

Despite common misconception, homes tend to burn long after the initial wall of flames passes through due to the smoldering firebrands that gather near the structure and eventually catch fire<sup>37</sup>. Homes can act as a major source of fuel in spreading the wildfire, therefore reducing the number of burning structures will aid wildland firefighters in containing the fire.

### 2.2.1 Wildland Firefighting Methodology

Fighting a wildfire is a very complex task which requires intensive training and strategy. When firefighters are required to make quick decisions on what is the most effective way of containing and extinguishing the fire, there are multiple different methods to choose from.

One tactic used to control wildfires is burnout. This is when firefighters pre-burn the brush just inside the control line using torches. This ensures that the flames will not escape the boundaries. Similar to burnout, back burn contains the fire by setting a controlled blaze starting at the control line, downwind of the main fire in order to push back and burn all the fuel that remains between the fire and control line. Another method of wildfire suppression is flanking. Flanking is when firefighters start snuffing the fire from behind where all the earth has already been burned and go around the whole perimeter of the property.

One of the more strategic methods of attacking a wildfire is called hotspotting. This is when the firefighters pay special attention to the hottest and most active parts of the fire which are the most dangerous and will most likely spread. This includes diverting extra manpower to snuffing the embers that erupt from the hottest part of the fire to make sure they do not reignite. In addition to hotspotting, firefighters might decide to focus on a certain hotspot that needs to be suppressed immediately and extinguish by applying some combination of dirt, water, or fire retardant. This method is called knockdown.

When fighting a wildfire, it is not only important to focus on the hottest and most active parts of the fire, but also considering the land that has already been scorched. While the fire is moving, some firefighters might be assigned to cold-trailing where they follow the fire and comb through the remains to make sure there are no embers that could possibly reignite. Mop-up is a similar method of containment where firefighters check along the control line and douse any embers that could have traveled across.

---

<sup>36</sup> Moussa, Mechanism of smoldering of cellulosic materials, (1977)

<sup>37</sup> *Learn More About Wildfires*, (2019)

One very popular, yet controversial tactic is aerial firefighting. This is when the firefighters use planes or other aerial resources to spray water and/or some sort of fire-retardant foams and gels. This technique has been very controversial because it is expensive and harmful towards the environment and can be dangerous<sup>38</sup>.

### 2.2.2 Building Construction Materials

Most modern homes are considered Type 5: Wood-Framed construction, which is when the walls and roofs are constructed from combustible materials, usually wood and the rooftop is ceramic or asphalt shingles. Studies done by both UL and NIST report that this lightweight construction type will most likely fail within minutes of direct wildfire exposure<sup>39</sup>. This is important information for this project in knowing what the average home is constructed from and translating that to the vulnerability of the structure in the event of a firebrand attack.

Current techniques for structural wildland fire protection includes pre-wetting of parts of the house, as well as any dead vegetation and landscaping. A study done in 2013, researched the effectiveness of preventing the fire from spreading from the wildland fire to the structures by pre-wetting using water, Class A foam and gel agents. The results showed that water and foam have very little effect on preventing radiant ignition of any material after prolonged radiant exposure, however the gel agents did prove to delay ignition. By delaying ignition, the number of structures effected by the firebrands would potentially be reduced because it would take longer for the fire to spread. However, these results are considered an unrealistic representation of wildfire because they only focused on radiant exposure<sup>40</sup>.

## 2.3 Structural Vulnerabilities

In a firebrand shower, a short-range exposure to a large quantity of smoldering and flaming firebrands<sup>41</sup>, there are different parts of the residential structure that would be more vulnerable to ignition due to accumulation of firebrands. Different parts of the house, such as the deck, roof and windows are more vulnerable due to corners and crevices that catch the firebrands. Understanding where the structure for this project is most vulnerable to ignition will provide insight to where extra protection is required.

### 2.3.1 Deck

A previous study using full scale Continuous Feed Firebrand Generator, modified from NIST Dragon which produced firebrands from Douglas-fir wood pieces (7.9mm by 12.7mm) with at 8m/s wind speed<sup>42</sup>. The NIST Dragon is an apparatus designed to generate a controlled size and mass distribution of glowing firebrands to simulate a wind driven firebrand shower<sup>43</sup>. This study was conducted to determine the influence of various conditions for the firebrands to arrive at the deck location. The experiment was conducted with three deck made from three

---

<sup>38</sup> Brooks Hays, *10 Strategies Firefighters Use to Fight Wildfires*, (2018)

<sup>39</sup> Randy Frassetto, *Understanding Building Construction Types*, (2012)

<sup>40</sup> Karl Meredith, *A comprehensive model for simulating the interaction of water with solid surfaces in fire suppression environments*, (2017)

<sup>41</sup> Morgan J. Hurley, *SFPE Handbook of Fire Protection Engineering*, (2016)

<sup>42</sup> Manzello, *Experimental Investigation of Wood Decking Assemblies Exposed to Firebrand Showers*, (2017)

<sup>43</sup> *Standard Firebrand Generator*, (2014)

different types of wood Cedar, Douglas-fir and Redwood, and Redwood is the material used in this project to construct the deck. The results from the study clearly showed that the accumulation of firebrands poses a danger of ignition, specifically, self-sustaining smoldering ignition of the deck. This would eventually transition to smoldering combustion. When compared to studies performed at wind speeds of 6m/s, it was observed that there was less accumulation of firebrands on the surface of the deck under 8m/s than 6m/s. Another important observation was that the firebrands accumulated around the corner of the deck under 8m/s, whereas at 6m/s the firebrands accumulated more towards the front of the deck, as seen in Figure 3. When the firebrands accumulated in the corner, it resulted in flaming ignition 5 out of 6 times, whereas when the firebrands accumulated towards the front, that they only ignited once<sup>44</sup>.

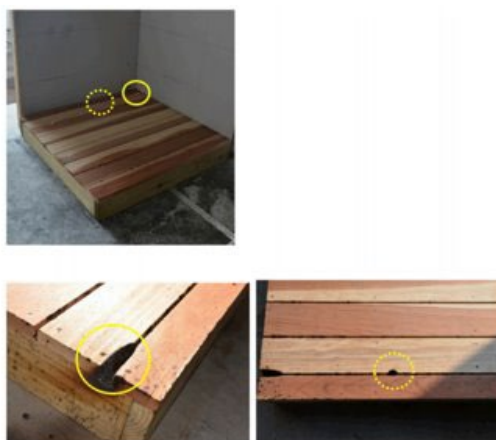


Figure 3: Redwood decking ignition by firebrand showers<sup>45</sup>

### 2.3.2 Roof

In a study conducted by the University of North Texas, a house model was constructed and then the structure was showered in firebrands demonstrate the vulnerabilities to ember exposure on a variety of roof configurations and materials as seen in Figure 4<sup>46</sup>.



Figure 4: Burning pine needle mulch (center) and bark mulch (left). Pine needle debris next to the roof dormer also ignited<sup>47</sup>.

---

<sup>44</sup> Manzello, *Experimental Investigation of Wood Decking Assemblies Exposed to Firebrand Showers*, (2017)

<sup>45</sup> Ibid

<sup>46</sup> Quarles & Sindeclar, *Wildfire Ignition Resistant Home Design Program*, (2011)

<sup>47</sup> Ibid.

The results from this demonstrated that roof valleys and areas of the roof that intersect with a dormer can be easily ignited by embers because the firebrands are more likely to accumulate there (Figure 5)<sup>48</sup>.



*Figure 5: Damage to the roof covering after ignition of the pine needle debris in the valley<sup>49</sup>.*

Another vulnerable part of the roof where firebrands are likely to cause fires is in the gutters, as seen in Figure 6. Smoldering embers can easily ignite any pine needles or debris that accumulates in the gutters both prior to and during a wildland fire. It is not uncommon for debris that accumulates in vinyl gutters to ignite and detach from the wall, as well as cause the siding to deform and expose the sheathing underneath<sup>50</sup>.



*Figure 6: Firebrands accumulating near the roof dormer<sup>51</sup>*

---

<sup>48</sup> Ibid.

<sup>49</sup> Ibid

<sup>50</sup> Cohen, *Relating Flame Radiation to Home Ignition Using Modeling and Experimental Crown Fires*, (2004)

<sup>51</sup> Manzello, *Experimental Investigation of Wood Decking Assemblies Exposed to Firebrand Showers*, (2017)

### 2.3.3 Siding

A study evaluating the time to ignition of various when exposed to radiant heat found that the time to ignition ranged from 4.5-16 minutes. The range in time is likely due the updraft that came off the wood siding causes the pilot flame at the top of the wall sections to extinguish. Both types of vinyl sidings that were tested did not result in flaming combustion, however they both started to deform almost immediately, which exposed the sheathing material underneath<sup>52</sup>. Similar results were found in another study which found that an accumulation of firebrands transitioned from smoldering ignition to flaming ignition, melting the adjacent vinyl siding as seen in Figure 7. Ignition of the wall also occurred for the untreated cedar shingle siding however the fire retarded cedar siding did not reach ignition<sup>53</sup>.



Figure 7: Flaming ignition of firebrands causing vinyl siding to melt<sup>54</sup>

### 2.3.4 Structural/Compartment Firefighting Methodology

According to the International Fire Code, each building has minimum requirements for what types of fire suppressions systems must be installed depending on the occupancy and total area of the building. Based on the height and capacity of the structure, the building must have fire detection systems that can alert emergency response teams and activate suppression systems to control the smoke and/or extinguish the fire. These codes only focus on interior fire protection methods because a feasible exterior system has not yet been developed.

One of the most common structural fire suppression tools is the fire extinguisher which applies an extinguishing agent to reduce the temperature of the burning fuel, displace/remove the oxygen, or stop the chemical reaction. There are different types of fire extinguishers based on the types of fire that they are designed for (ordinary combustibles, flammable liquids, electrical fires, etc.).

---

<sup>52</sup> Ibid.

<sup>53</sup> Manzello, Suzuki, & Hayashi, *Enabling the study of structure vulnerabilities to ignition from wind driven firebrand showers*, (2018)

<sup>54</sup> Ibid

Internal sprinkler systems are very required in many different types of business and municipal buildings because of their ability to contain the smoke from a compartment fire and reduce the amount of damages and losses. Another common system is the CO<sub>2</sub> Fire Suppression System which works as a larger scale dry chemical extinguisher which releases a heavy blanket of gas and reduces the amount of oxygen fueling the fire.

## 2.4 Firebrands

Quarles defines firebrands as “embers traversing up and over the established fire line create a risk of structure fires for homes in the WUI. Beyond the immediate reach of already an already constrained fire service, they have the potential to amass along roofs, gutters, and tight corners in building construction. Given enough time, accumulation, or both, these embers can create a hotspot at a property”<sup>55</sup>. This is the working definition of the threat for the fire suppression system.

In a recent study, *Pathways to Fire Spread in the WUI* by Gollner et al, firebrands were identified as one of the primary sources of ignition in the WUI<sup>56</sup>. The report highlights three critical aspects of firebrands. The first is the production of the embers. Firebrand size has been studied by several experiments and field observations. Generally speaking, firebrands can range in size from 0 to 4 cm<sup>2</sup><sup>57</sup>. The NIST Firebrand Generator produces firebrands of approximately 0.5 cm<sup>2</sup> in size for experimental tests that included conditions often found in wildfires, such as wind up to 10 m/s<sup>58</sup>.

Firebrands have been known to travel well in advance of the fire. A NIST study recorded firebrands igniting properties for 9 hours after the line had passed through a neighborhood<sup>59</sup>. Other factors that influence transport time include particle size, wood type, mass, and shape. Overall, firebrands in a large fire can travel up to hundreds of meters. Accumulation is a concern over time.

Work has just begun at NIST and IBHS on consistently delivering particles for burning and subsequent analysis through an improved continuous delivery system<sup>60</sup>.

### 2.4.1 Firebrand Production

Heat radiating from the wildfire fronts warms the air and preheats any flammable fuel which causes it to ignite more rapidly when the flame front arrives. The gases generated by the wildfire creates convection columns which carry firebrands over any breaks in the fire, such as roads or rivers, and can accumulate and cause spot fires. Similarly, conduction carries the flames through the air over firebreaks.

---

<sup>55</sup> Quarles, *Vulnerabilities of Buildings to Wildfire Exposures*, (2012)

<sup>56</sup> Gollner, Hakes, Canton, & Kohler, *Pathways for Building Fire Spread at the Wildland Urban Interface*, (2015)

<sup>57</sup> Ibid.

<sup>58</sup> Manzello & Suzuki, *Experimentally Simulating Continuous Wind Driven Firebrand Showers in Wildland-Urban Interface Fires*, (2013)

<sup>59</sup> Maranghides, McNamara, Mell, Trook, & Toman, *A Case Study of a Community Affected by the Witch and Guejito Fires*, (2013)

<sup>60</sup> Manzello & Suzuki, *Experimentally Simulating Continuous*, (2013)



## 2.4.2 Spotting Distance

Spotting distance is a measurement of how far a firebrand travels, then igniting the area where it lands. There are multiple research efforts over the years that have aimed to understand firebrand transport. Table 1 provides a concise overview of this research from Koo’s 2010 study on firebrands and spotting distance.

Author	Year	Experiment	Firebrand model	Plume and wind model
Tarifa <i>et al.</i>	1965–67	Burning firebrands in wind tunnel	Sphere, cylinder with combustion	Given launching height in constant horizontal wind, inclined convective plume (Nielsen and Tao 1965)
Waterman (and Tanaka)	1969	Size and number distribution at generation (Waterman 1969) Ignition of various fuel materials by firebrands (Waterman and Tanaka 1969)	–	–
Vodvarka	1969	Size and number distribution	–	–
Lee and Hellman	1969–70	Particles in vertical plume generator (1969)	Spheres with combustion (1970)	Turbulent swirling natural convective plume (1969)
Muraszew and Fedele	1974–77	Burning firebrands in wind tunnel and fire whirl in vertical channel (1975)	Statistical model (1976)	Fire whirl (1977)
Clements	1977	Firebrand combustion in terminal velocity	–	–
Fernandez-Pello <i>et al.</i>	1982, 1998, 2006	–	Sphere with combustion (Fernandez-Pello 1982) Disc, cylinder and sphere (2006) Cylinder with combustion (Muraszew and Fedele 1976)	Given launching height (1998), McCaffrey plume (2006) in constant boundary layer wind Launching height from flame structure analysis in constant horizontal wind
Albini	1979–83	–	–	–
Woycheese and Pagni	1996–2000	Burning firebrands in wind tunnel	Non-dimensional model with combustion (Kinoshita <i>et al.</i> 1981)	Baum and McCaffrey plume model (Baum and McCaffrey 1989)
Knight, Ellis <i>et al.</i>	2001	Various firebrand combustion in vertical wind tunnel	–	–
Colin <i>et al.</i>	2002	Statistical survey on fires and monitoring	Statistical model (SALTUS program)	–
Himoto and Tanaka	2005	–	Disc without combustion	Given launching height in turbulent boundary layer
Manzello <i>et al.</i>	2004–08	Fuel bed ignition by firebrands, generation from a burning tree; firebrand attack on structures using firebrands generator	–	–
Porterie <i>et al.</i>	2007	–	Small world network model (Porterie <i>et al.</i> 2007); disc with combustion (Sardoy <i>et al.</i> 2007)	Steady-state crown fire (Porterie <i>et al.</i> 2005)
Koo, Pagni and Linn	2007	–	Disc and cylinder with combustion	HIGRAD/FIRETEC wildfire model (Linn and Cunningham 2005; Linn <i>et al.</i> 2005)

Table 1: Compendium of Firebrand Research <sup>61</sup>

As seen, there are a variety of ways that various experiments and studies have aimed to model firebrands, and separately model the plume and wind transporting the brands.

## 2.4.3 Limiting Fires from Firebrands in Residential Structures

Beginning in the 1940’s, a major population increase occurred forcing families to settle adjacent to fire-prone forests and woodland areas commonly known as the Wildland-Urban Interface (WUI). The growing population in along with the current preference for rural landscapes with large properties, have contributed to widespread population increase in non-metropolitan areas. Rich in its natural amenities and resources, more than 50% of new housing areas are classified as severe-fire zones due to their proximity the WUI.

More than 1,000 homes are lost to wildfires annually in California alone. The primary focus of this research will be on residential structures because homes are considered one of the largest sources of fuel for the spreading of wildfires. If an external fire-suppressant system could

<sup>61</sup> Eunmo Koo, *Firebrands and spotting ignition in large-scale fires*, (2010)

be implemented on private residences in remote areas that are prone to wildfires, that could reduce the damages that result from forest fires<sup>62</sup>.

Of 87 percent of the large wildfires reviewed, the protection of private property was a major reason for firefighting efforts. If an external water spray system could keep these homes safe, the already limited fire-protection resources could be utilized in more effective ways such as protecting the local hospitals and schools that would likely be used to house and protect the people of the community that might not evacuate.

## 2.5 Fire Suppression Systems

Per SFPE Chapter 19 on Smoldering Combustion:

*“A smoldering fire can be extraordinarily difficult to suppress. Experiments on heaps of coal show that smoldering requires large amounts of water. For example, the amount of water required to suppress smoldering coal was measured to be in the range from 1 to 2 liters of water per kg of burning fuel. And smoldering requires low oxygen concentration to be smothered, around 10% O<sub>2</sub>, compared to 16% O<sub>2</sub> for flaming [Hadden et al. 2013, Belcher et al. 2010]. Oxygen removal is insufficient unless it is continued until the whole fuel bed is cooled to a point where oxygen readmission will not cause re-ignition. Because cooling of a fuel bed is a very slow process in general (long thermal response time), this means that the holding time for smothering are much longer for smoldering than for flaming (months vs. h) [Hadden and Rein 2011].*

Extinguishing fluid agents have the tendency to follow higher permeability channels. This causes them to miss in-depth burning zones, which makes suppressing large fuel beds difficult. The channels occur when a significant amount of water takes the same flow path, limiting the surface area between the suppressing agent and the burning fuel. In addition, in the places where there is a higher flow velocity, the permeability is increased, and thus more water is required to suppress the fire<sup>63</sup>. When compared on a small pile of coal, three methods of water suppression, pipe, shower, and spray, showed that the method that was the most efficient use of water was the shower. However, the results from the spray tests were found to have less runoff than the other methods<sup>64</sup>. In another study, a variety of extinguishing agents, such as water, water with additives, as well as N<sub>2</sub> and CO<sub>2</sub> gases, were also compared on a small pile of coal. The CO<sub>2</sub> gas, when supplied under the bed of coal, was found to be the most successful<sup>65</sup>.

Currently there is very little available data control or suppression of smoldering firebrands, therefore it was assumed that firebrands would react to water comparably to smoldering coal piles. Considering our system, the most effective means of suppressing a glowing ember fire appears to be through the use of water spray. Water spray has several effects on the combustion itself. The first is gas phase cooling, which is the removal of heat due to the

---

<sup>62</sup> Jeff Daniels, *California spends more than half of annual fire budget in 40 days, as big blazes continue to burn*, (2018)

<sup>63</sup> Hadden & Rein, *Burning and Water Suppression of Smoldering Coal Fires in Small-Scale Laboratory Experiments*, (2011)

<sup>64</sup> Ibid

<sup>65</sup> M. Toumisaari, *extinguishing smoldering fires in silos*, (1998).

evaporation of water. For our scenario, there are efficiency issues implied as water will not all directly contact the firebrand, nor will it be able to remove heat from the center of the brand. The second method of extinguishment is oxygen depletion, which is the volumetric expansion of steam displacing availability of pure oxygen. For our problem, the high winds in the environment will unfortunately not create a scenario will oxygen depletion will play a large role. The third extinguishment factor is the wetting and cooling of the fuel surface. It is likely that this will be the dominant extinguishment method, as it reduces the gasification rate of the fuel. However, this will still be challenging for the water spray to do, as there are issues of penetration in a porous firebrand. When the firebrands have accumulated on the surface of the house, radiation attenuation is another factor. It is gas phase cooling which reduces re-radiation effects from the flame to the fuel. In this case, the water acts as a graybody radiator, reducing the radiative effects. The final effect that a water spray system would have on the fire are kinetic, such as the introduction of more turbulence into the scenario.

Water spray has several performance criteria, as listed in Chapter 42 of the SFPE handbook. This includes droplet size, penetration, and motion. Generally, mean droplet diameter can be calculated by the equation

$$d_m \propto \frac{D^{2/3}}{p^{1/3}} \propto \frac{D^2}{Q^{2/3}}$$

Where  $d_m$ = mean droplet diameter,  $D$  = Orifice diameter,  $P$ = Pressure,  $Q$ = Rate of water flow. Another variable is the cone angle, which dictates the range of application for a single orifice. Other variables also include the velocity and mass flow rate of the water from the nozzle.

## 2.6 Existing Designs

This project took a first attempt at investigating the fire threat from firebrands on residential structures and using that information to propose an exterior fire protection system design that can improve the survivability of the structure, while remaining feasible for the average homeowner be able to afford to install in their home. There are a handful of existing system and patent designs that are more theoretical instead basing on a quantified threat. However, there are aspects of these designs that were implemented into the final design of this project.

One residential water system has been tested and deployed in the field against an active wildfire. The Wind-Enabled Ember Dousing System (WEEDS) was activated in November of 2003<sup>66</sup>. During this fire, the house and some surrounding areas were unaffected. As it is the most heavily documented instance of a system successfully protecting a house, it will serve as a baseline for discharge criteria. The system used 5,000 gallons of water over the course of 5

---

<sup>66</sup> Mitchell, *Wind-enabled Ember Dousing*, (2006)

hours, which is a considerable amount for the average homeowner. The study lists the discharge criteria as the following<sup>67</sup>.

Droplet size 1.4 to 2 mm

Cone angle of 45 degrees (approx.)

Velocity of 4 m/s

Mass flow rate of 1 gal/min per nozzle

This system was not designed around a set fire load, but instead focused on the ability for the droplets to be dispersed evenly and into the wind, with the idea that water would land on the same locations that firebrands would. This theory has not been verified in any other firebrand application.

### 2.6.1 Existing Patents

During the research process, a handful of existing patents for exterior fire protection systems to protect residential properties from wildfires were discovered. Although they all have detailed figures and descriptions, most of the technology described does not yet exist or is not backed by legitimate engineering. However, there are a lot of aspects of them that could be contributed to this project.

U.S. patent number US5165482A, Fire Deterrent System for Structures in a wildfire hazard area includes an infrared, ultraviolet or electro-optical fire detector to detect the presence of a fire in the immediate vicinity of the house as well as an anemometer to measure the wind magnitude and direction to make activation and extinguishment more efficient. Additionally, it includes computer controlled monitors the water level in a storage tank and controls activation of water delivery systems to apply water to vegetation, roof, walls, etc.<sup>68</sup> A unique aspect of this design is the water recovery system which consists of a recovery valve connected to a series of recovery pipes which can be connected to recovery spouts from an existing gutter system, as seen in Figure 8 on the next page. A feature that would be helpful when the homeowner needs evacuate their property before the wildfire reaches is a manual access panel for homeowner, emergency personnel, and can be used to manage the system parameters. It would be able to be activated by homeowner from a remote location by touch-tone phone connection to a telephone access port on the computer. A con to this is that cellular service can be down during most wildfires.

---

<sup>67</sup> Ibid.

<sup>68</sup> Dennis Smagac, *United States Patent No. 5165482*, 1992

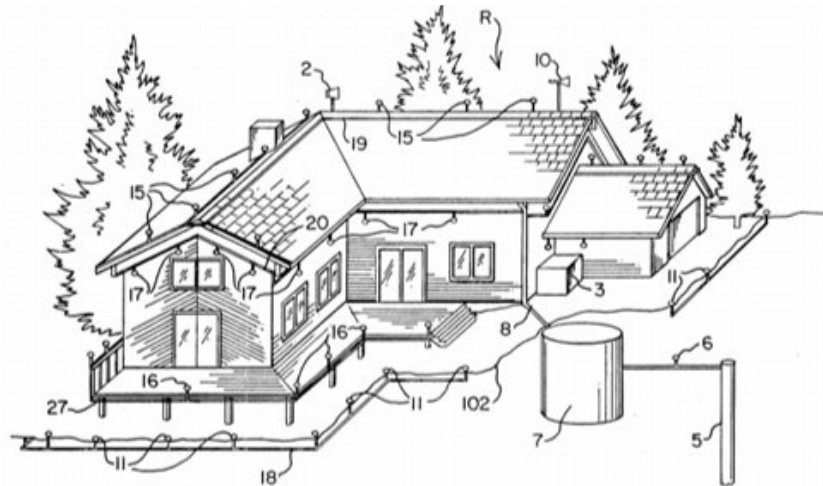


Figure 8: Sketch of System Design<sup>69</sup>

U.S. patent number US4428434A, Figure 9, is an Automatic Fire Protection System which also considers that residential water supply might not be enough to protect a home from a firebrand attack. It utilizes an available nearby water supply. The average pool is 50-60,000 gallons which is sufficient to run this system for 12-15 hours. This avoids the problems that might result from a low public water pressure during a wildfire. This patent also includes temperature sensors placed on the structure to monitor a plurality of locations. One sensor is a direct air temperature sensor which reads the actual air temperature and the other measures the radiant heat. Not only does this system have sprinklers to protect the structure, it also suggests placing sprinklers to extinguish any nearby vegetation that could potentially catch fire from firebrand accumulation<sup>70</sup>.

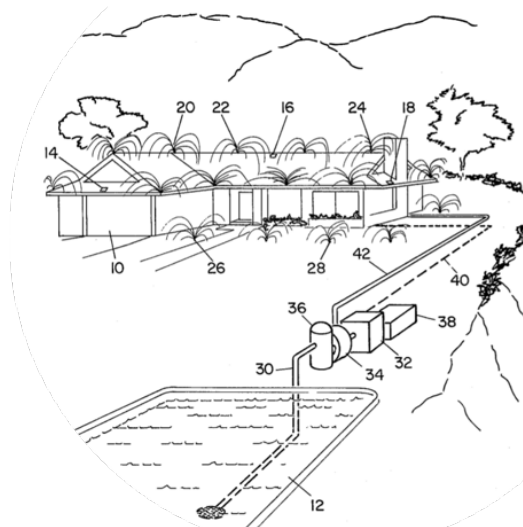


Figure 9: Sketch of System Design<sup>71</sup>

<sup>69</sup> Ibid

<sup>70</sup> Jonathon L Gelaude, *United States Patent 4428434*, (1984)

<sup>71</sup> Ibid

U.S patent US20110226497A1, which is a dynamic water shield fire protection system is a pressurized system through main water pipe provides water pipes connected to a plurality of nozzles via connecting pipes. The unique part of this system is that the nozzles are designed to flatten the water, to become a film covering the surface to the home<sup>72</sup>. Similar to the others, this patent does not rely on the public water supply and utilizes a pool, nearby lake or tank. This system activates automatically using fire detectors to determine if there is vulnerability or an accumulation of burning firebrands. Figure 10 demonstrates the conceptual water film system.

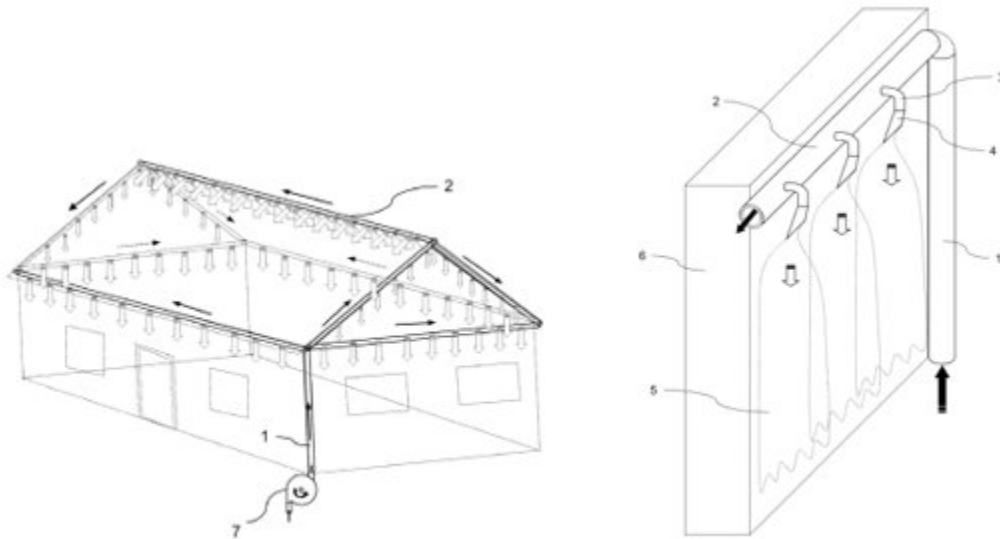


Figure 10: Sprinkler system layout and visual of water film covering siding of house<sup>73</sup>

### 2.6.2 Spray Safe

SpraySafe is an Autonomous Fire Suppression system designed by Johnson Controls to pinpoint the location of an early stage fire on a high-rise building with combustible cladding materials and autonomously fight it. It is also designed to help contain fires from the outside of the building and preventing flashover in places that are out of reach for firefighters. Elements from this design would be helpful to include in the design such as the array IR flame detectors, a deluge valve, and the graphical user interface. The array IR flame detectors, visual flame detectors, employ flame recognition technology to confirm fire by analyzing near IR radiation using a charge coupled device. Figure 11 on the following page helps to illustrate the concept of operations of the system.

This would be helpful in this project for autonomously detecting an early stage fire that starts from an accumulation of firebrands on the side of the house. A deluge valve is a type of system actuation valve that is opened by a detection system that is installed in the same areas as the spray nozzles or by remote manual operation supplying water to all spray nozzles. The

<sup>72</sup> Innocent Yamodo, *United States Patent 20110226479*, (2011)

<sup>73</sup> Ibid

graphical user interface allows users to interact with electronic devices through visual indicators which would allow the homeowner to activate the system from a remote location<sup>74</sup>.



*Figure 11: Spraysafe Protecting Parts of the Structure Firefighters Cannot Reach<sup>75</sup>*

---

<sup>74</sup> SPRAYSAFE Autonomous Fire Suppression (AFS) Technology, (2018)

<sup>75</sup> Ibid

### 3. Methodology

In order to accurately address our problem, the framework from the *SFPE Engineering Guide to Performance-Based Design* was utilized. This process provides a workflow that can be applied to any engineering design problem in the fire protection engineering industry. An example of the flowchart is provided as Figure 12.

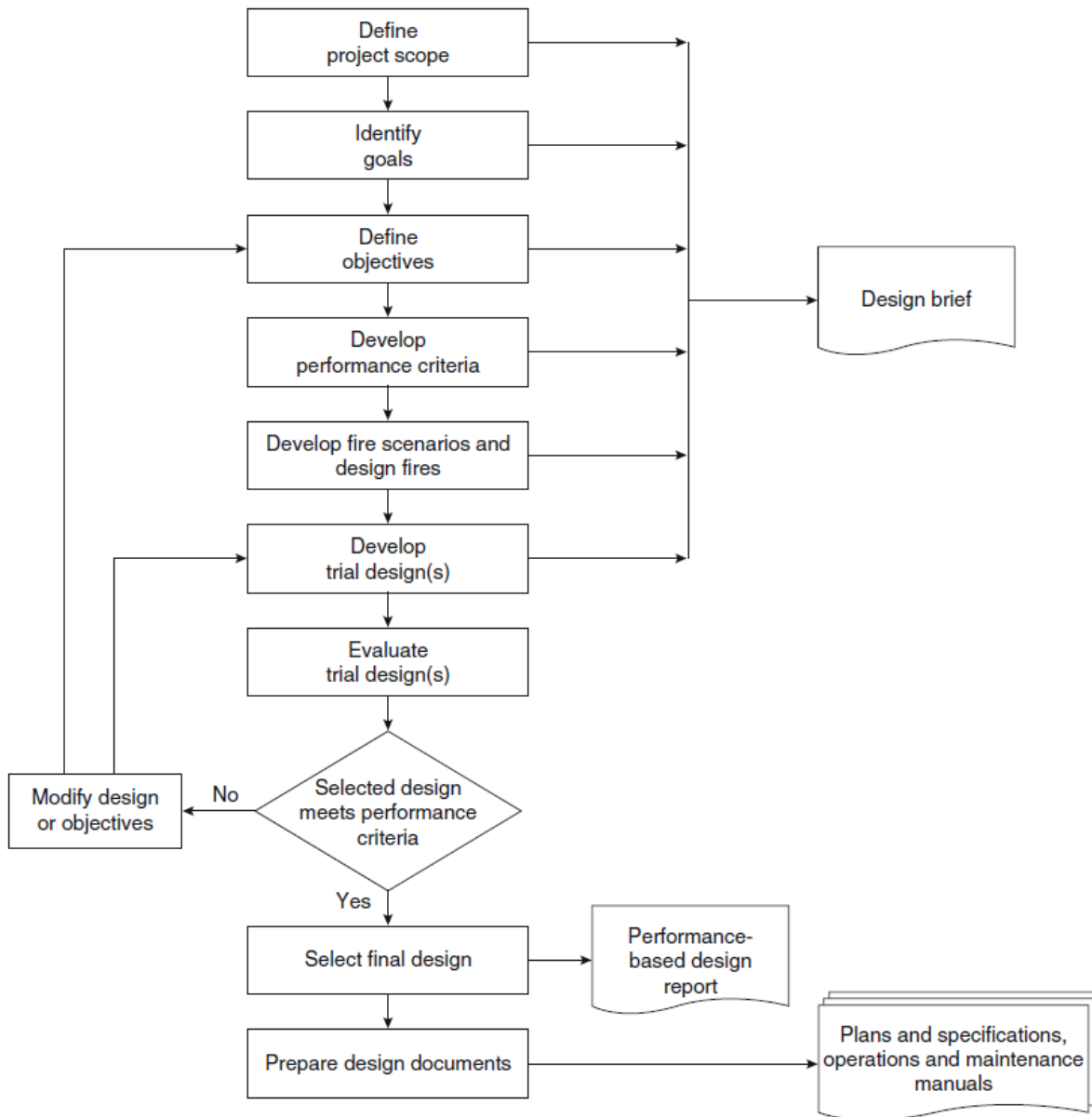


Figure 12: SFPE Performance-Based Design Process<sup>76</sup>

The implementation of the SFPE design process is incorporated in an overview flowchart located in Appendix E, in addition to the details outlined in the following chapters.

<sup>76</sup> Morgan Hurley, *SFPE Handbook of Fire Protection Engineering*, (2016)



The first step in the process is to identify the project scope. The project scope defines exactly what issues will be solved. After a review of stakeholders involved in the wildfire process, it was determined that individual homes are not the focus of the many hardworking local, state, and federal agencies who have their resources dedicated to the fire line. As Chapter 2 of the report demonstrated, the threat of firebrands to unattended evacuated homes beyond the fire line represents a significant risk to individual homes and communities. Therefore, the scope of the design process is limited to prevent embers created by wildfires from destroying individual properties. As will be discussed, significant work is still required in other aspects of the greater issue of wildfires. However, this report aims to address a problem that has not been discussed as in depth before.

The second stage of the performance-based design process is to identify goals. Goals are broad ranging qualitative statements which state how the fire protection system is expected to perform during a fire event. Common goals include life safety, health, property protection, or continuity of business operations.

The third step in the process is to state objectives. Objectives are the milestones that a conceptual system would have to meet in order to reach any defined goals. This could include other milestones that stakeholders require to be met beyond generic goals, for instance to have a system activate before a critical milestone or event occurs, causing unacceptable levels of damage.

After objectives have been created, specific performance criteria are then developed to meet both defined goals and objectives. Performance criteria is technical data which creates limits on when and how a fire protection system should respond. These values could include critical heat fluxes, heat release rates, activation times, water discharge density, smoke concentration, flame heights, or temperatures.

The first four stages all largely coincide with a planning process around protecting a hazard. The next step in the process is to develop fire scenarios. A fire scenario is comprised of characteristics of the building, the fire, and occupants. While the scope of the project is to protect homes that are unattended, it will still be important to acknowledge potential occupant actions towards protecting the home for the fire scenario. Fire scenarios in interior fire protection applications typically use a risk-based analysis. For applications that have a large amount of data, this approach is appropriate. However, the WUI firebrand exposure problem does not have a large quantity of available data behind it that would be conducive to a statistical approach. Instead, the fire will be quantified by examining various cases and experiments in order to demonstrate the spectrum of potential firebrand scenarios impinging on a house. To design a fire scenario, the duration of attack, fire load, and mechanism of ignition will be outlined.

Once a fire scenario has been determined, a potential system must be designed through a trial design. A trial design incorporates all components of the fire protection system in order to combat the fire scenario. These components include methods of detection, system spray characterization, and water supply.

Finally, the trial design was evaluated. This evaluation of trial design step is intended to match the system against the fire and determine its potential effectiveness. In the performance-based design process, if the trial design evaluation proves that the design is not effective, then an iteration of the design is required. All the way, documentation is important. Likewise, as some characteristics of firebrand attacks are not fully researched, further iterations of an external residential sprinkler will be required.

## 4 Project Scope, Goals, Objectives, and Performance Criteria

### 4.1 Project Scope

The scope of this project is to prevent the embers created by wildfires from destroying individual properties. This would have a significant impact on stakeholders like property owners and insurance providers by reducing damages residential properties, as well as assisting fire officials in containing the fire. The focus on residential structures was determined due to their high vulnerability to firebrand attacks. In order to fully understand the scope of the project, a lot of research was done on the problem of wildfires, especially historical wildfire threat and type and number of structures commonly lost to wildfires.

### 4.2 Project Goals

The goal of this project is property protection by minimizing damage to the wood building from heat transfer from firebrand accumulation. The goal is to only protect the property from the time the individual homeowners leave until the fire service is able to intervene.

### 4.3 Project Objectives

#### 4.3.1 Detect fire

The system shall be designed to detect any flaming ignition that happens to the deck/siding of the home that occurs as a result of firebrand accumulation.

#### 4.3.2 Activate System

The system shall be designed to activate when the fire reaches the specified detection requirements. The fire is detectable when the flame height reached 3 inches.

#### 4.3.3 Apply Appropriate Water

Determining the appropriate amount of water to control the flames from firebrands from causing damage to the property while keeping in consideration the limiting factor of a low residential water supply during a wildfire event.

### 4.4 Performance Criteria

The team established performance criteria to inform the selection of system components. The performance criteria developed were:

- I. The fire before activation will burn with a heat release rate of 3539 kW (based on calculations shown in section 7.2)
- II. The mass flux required for flaming ignition for a firebrand pile is  $17.1 \text{ g/m}^2\text{s}$ .
- III. The risk is detectable after the onset of visible flame. When the flame height reaches 3 inches it causes the detectors to activate the system.
- IV. Deliver enough water to suppress the fire.

#### 4.4.1 Assumptions

These performance criteria were based on considering a set of assumptions. The assumptions specified were:

- I. The house is being attacked by firebrands from one direction. One limitation of this assumption is that it does not consider if the wind is hitting more than once side of the house at once. This assumption was made because there was no previous research on firebrand accumulation of a structure on more than one side.
- I. Zone in on a small corner section of the house where the siding and the deck meet. This is assumption was made because there is no data or previous research on larger scale firebrand attacks. It is recommended that there is further research on this to improve the suggested system design. A limitation of this assumption is that it does not consider if the firebrands accumulate into more than one pile and start more than one fire at a time. Per the FDS simulations performed, the proximity of accumulated particles was near the corner, location limited by the grid size. Therefore, only considering 1m from the house and the width of the side of the house is the discharge area is  $35' \times 3.28' = 114.8 \text{ ft}^2$ .
- II. The fire remains outside of the house. This assumption was made to reduce the complexity of the problem and to not consider if the fire burned through the siding and
- III. Suppression of the fire is defined as reduction of the heat release rate and decrease in the energy of the fire. The limitation with this assumption it does not really consider that suppression is a dynamic problem and that as the water is being sprayed on the firebrand pile, there is simultaneously more firebrands accumulating in the pile.
- IV. The piping and systems will be maintained and comply to code.
- V. The critical mass flux is equal to the mass loss.

#### 4.4.2 Mass Flux

Based on a study done using a continuous feed Firebrand Generator, with a feeding rate of 200g of firebrands every 15 seconds, and a wind speed of 6 m/s, the mass flux required for flaming ignition of firebrand piles was determined to be  $17.1 \text{ g/m}^2$ . Since the conditions of the study were similar to the fire scenario of this project, this mass flux will be used as a standard for ignition and determining activation of the system. For the purposes of this project, working under the assumption that all the energy from the mass of firebrands is converted to heat. This is a built in safety factor as it is not reflective of the real world. It was also assumed that flaming ignition of the deck occurred at a heat flux of  $10 \text{ kW/m}^2$ <sup>77</sup>.

#### 4.4.3 Flame Height

The property is determined to be at risk when the flame height reaches is detectable. When the flame height reaches 3 inches the firebrands have transitioned from smoldering combustion to flaming combustion. Once there is a visible flame of at least 3 inches, the system will activate and suppress the fire.

---

<sup>77</sup> Sayaka Suzuki, *Experimental investigation of firebrand accumulation zones in front of obstacles*, (2017)

#### 4.4.4 Water Supply

A residential water supply, especially in the event of a wildfire, is very limited. As seen by statistical fire weather data, wildfires are more likely to occur when fuels are dry<sup>78</sup>. The resulting dry fuels imply that the availability of water in the region is most likely low. Especially in areas prone to drought, the supply of water will be an area of concern. In order to mitigate the lack of water, it is suggested that the system utilize a home's well system or a large tank with a pump to make sure that there is enough water supply. It was calculated that the minimum flowrate necessary for the system is 69.24 (the calculations are shown in Section 7.2) and therefore the required discharge density is 0.26 gpm/sqft. The total amount of water required was 2077 gallons for 30 minutes of discharge.

---

<sup>78</sup> *California Fire Weather*, (2018).

## 5 Fire Scenarios

### 5.1 Number of Firebrands Attacking Structure

Based experimentally from J.C Thomas et. al, the worst-case scenario for firebrand flux was determined experimentally to be 1.0473 pcs/m<sup>2</sup> per second. This study used real world fuel including pitch pine. The collection distance ranged from 27 to 58 m<sup>2</sup>. For our scenario, it is therefore fair to assume that one firebrand will impinge on the structure per square meter a second<sup>79</sup>.

Various parts of the structure are found to have an increased vulnerability to firebrand attacks, such as the roof, gutters, tight corners, and the deck. In the areas of the roof where there is a valley, or where the roof intersect with a dormer, is at greater risk of catching fire due to firebrand accumulation. Debris and pine needles that build up in gutters over time can easily act as fuel in the event of a wildfire and the resulting fire can cause the siding to deform. Any tight corners, especially where the siding and the deck meet, is also at a higher risk when firebrands are attacking the structure because they get trapped and can potentially cause both the siding and the decking to catch fire.

A recent study focused on quantifying the heat flux from firebrand piles to an inert surface to isolate the heat flux produced when a recipient fuel ignites. Collecting data using thin skin calorimeters and thermocouples this study was able to evaluate the heat flux and temperature of a single fire and compare it to a pile of firebrands. Figure 13 is from a test with a pile of firebrands, breaking up the heat transfer of the data collected from a single thin skin calorimeter placed in the center of the pile. Reradiation is believed to play a role in the heating of the pile, which is consistent with the high temperatures. The left side of Figure 13 shows a similar plot of the components of heat transfer, but for a single 12.7mm birch firebrand, where convective losses from the main portion of the heat transfer, through reradiation also play an important role<sup>80</sup>.

---

<sup>79</sup> Suzuki & Manzello, *Experimental Investigation of Firebrand Accumulation Zones in Front of Obstacles*, (2017)

<sup>80</sup> Hakes, *Thermal Characterization of Firebrand Piles*, (2017)

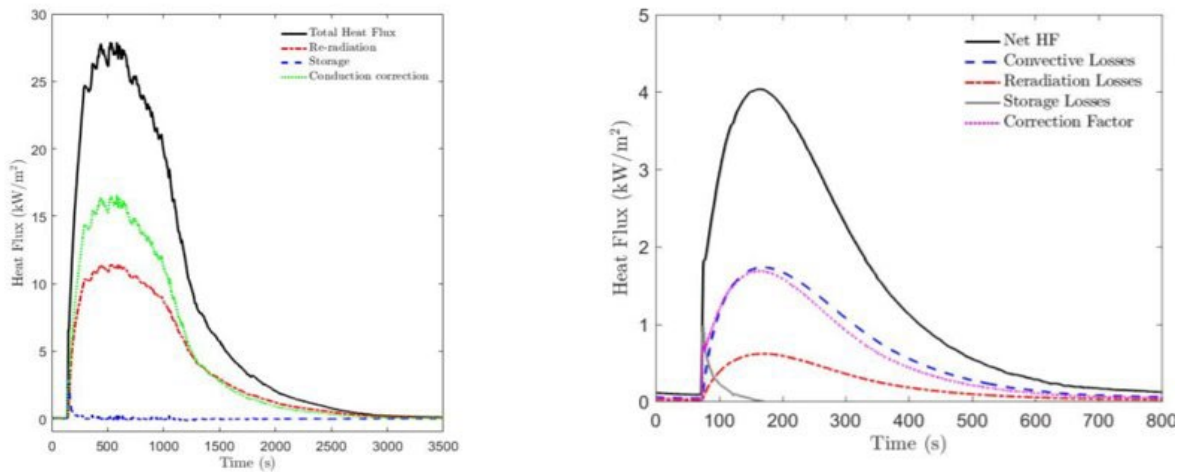


Figure 13: Heat transfer from a pile of firebrands and a single firebrand<sup>1</sup>

The most important variable affecting the heat flux curves and the net heating of the firebrand was found to be the mass of the pile size. The heat fluxes were observed to peak much higher under forced flow (wind) conditions. This is believed to be because the increased air flow produces more oxidation, resulting in a higher surface temperature of the firebrands and a higher estimated heat flux. This is important information when creating an energy balance to determine when the recommended system would activate during a wildfire and how long it would need to extinguish. In Figure 14, which was taken from the study, compares the average heat fluxes measured with the thin skin calorimeters under ambient and windy conditions. The dashed lines are for the test using 50g of firebrands and the solid lines represent 100g of 12.7mm firebrands<sup>81</sup>.

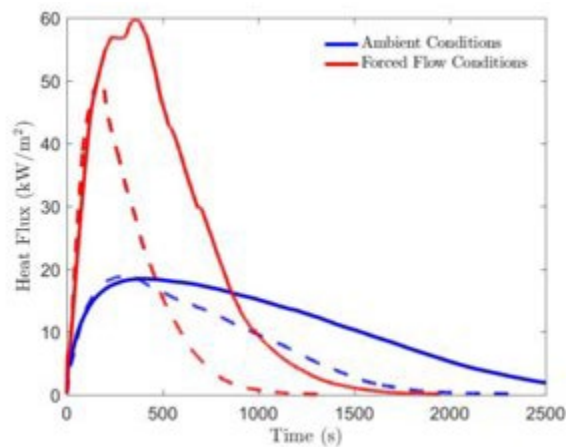


Figure 14: Heat flux under forced flow and ambient conditions<sup>82</sup>

Additionally, in this study, IR images were captured for 1, 10 and 15 minutes into the ignition test where the firebrands were ignited using a propane flame with an applied wind of

<sup>81</sup> Hakes, *Thermal Characterization of Firebrand Piles*, (2017)

<sup>82</sup> Ibid

1.84 m/s from the right. In Figure 15, the pile of firebrands after 1-minute shows some of the heat is surrounding the firebrand pile, however the highest temperature is on the inside of the pile. In the middle image, the ignited fuel at the back of the pile has the highest temperature, and in the bottom, the remaining firebrands still have high temperatures, despite it only appearing to be a pile of ashes with no visible combustion<sup>83</sup>. Note the change in scale for the IR images. The ignition of the firebrand pile appears earlier than is usually reported from other studies, which suggest the firebrand piles are known to ignite WUI fuels long after the fire front has passed through. This observation is supported by the data displayed in the graph comparing the temperatures collected from the thermocouples and thin skin calorimeters averaged over a 10g pile of firebrands (Figure 16). It is important to note that there it is a possibility for the accumulation of the firebrands to be a threat early on into a firebrand attack and that the recommended system design should take this into consideration.

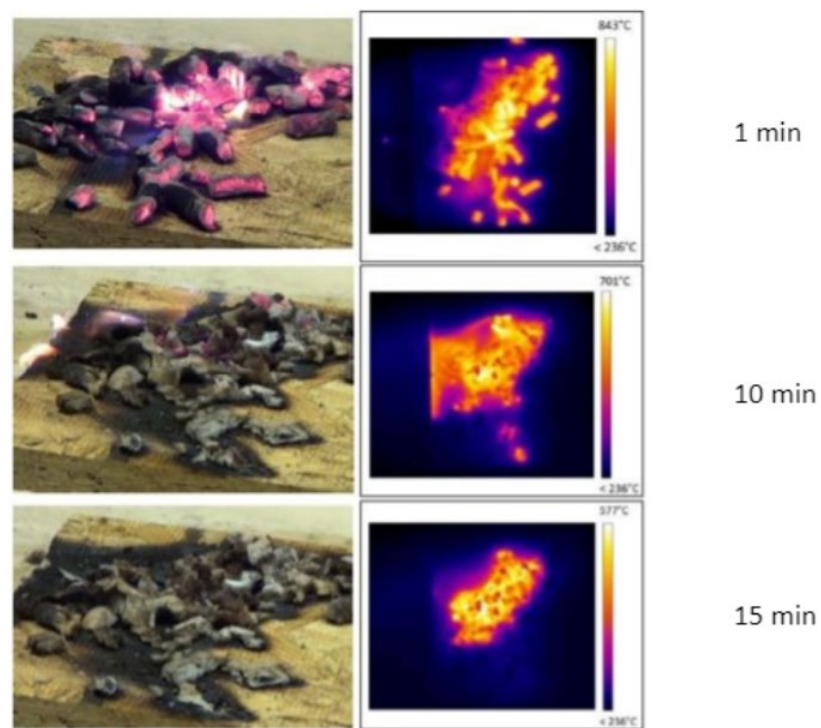


Figure 15: Visual IR images captured for 1,10 and 15 minutes<sup>84</sup>

<sup>83</sup> Ibid

<sup>84</sup> Hakes, *Thermal Characterization of Firebrand Piles*, (2017)



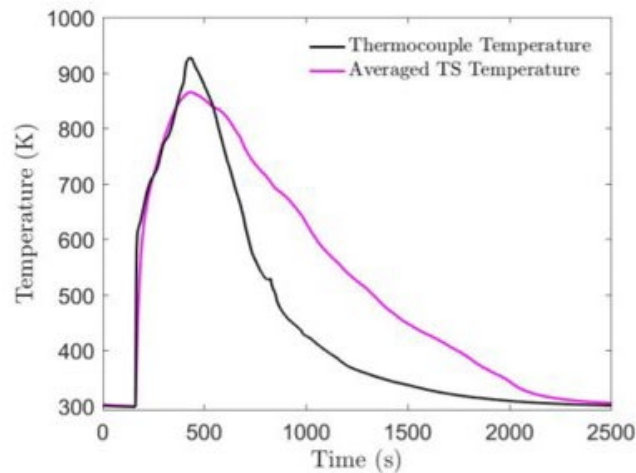


Figure 16: Thermocouples and thin skin calorimeters averaged over a 10g pile of firebrands<sup>85</sup>

## 5.2 The House

For the purposes of this research, the focus will be to design an external water spray system suitable for a residential structure that is about 2,500 square feet, which is the average house size in the U.S.<sup>86</sup> on an 8,500 sq-ft which is based on the median lot size of a single-family home in America in 2015 property<sup>87</sup>. Assuming the homeowner followed all the recommendations of Firewise USA, in this scenario there will not be any vegetation or mulch in the extended defensive zone which includes 30 ft around the perimeter. In the back of the house there will be a 350 square foot wooden deck, made from Redwood. The deck area is based on the average deck size according to<sup>88</sup>. Redwood was chosen because it is one of the most common woods used in deck construction<sup>89</sup>, especially in the west coast of the United States, because it is naturally stable, and according to the new code, the deck conforms to ASTM E-84 Class B flame spread if the decking material has a net peak heat release rate of less than 25 kW/sq-ft, and the heat release rate of Redwood is around 13 kW/sq-ft<sup>90</sup>. The roof of the model house will be constructed with a 6/12 pitch from concrete shingles because it follows the Firewise recommendation to have a Class-A fire rated roofing as well as being popular for use on residential homes because of its durability<sup>91</sup>. According to Firewise, homes with fire-resistant siding are more prepared for wildfires. Fiber-cement siding is very popular because it is very low-maintenance, made from recyclable materials and due to its resemblance to wood siding without the high flammability of wood<sup>92</sup>. The model home will be equipped with dual pane tempered glass windows which is suggested by Firewise. The front of the house is facing north

<sup>85</sup> Ibid

<sup>86</sup> Perry, *New US homes today are 1,000 square feet larger than in 1973 and living space per person has nearly doubled*, (2016)

<sup>87</sup> Siniavskaia, *Lots in 2015 are Smallest on Record*, (2016)

<sup>88</sup> Schmidt, *Outdoor Deck Size Tips*

<sup>89</sup> Walsh, *Wood Decking Materials*

<sup>90</sup> *Technical Data Sheet Redwood*

<sup>91</sup> Coddinton, *Which Roofing Materials are the Most Fire Resistant?*, (2017)

<sup>92</sup> Formisano, *The Most Popular Siding Choices for the Home*, (2018)

with a complex roof due to a dormer on the second floor, which will be added as a collection point for firebrands. On the east side of the house there will be a double driveway (24' by 22') which will create a small fuel break in the case of a wildfire. It is recommended by Firewise to have driveways be at least 12 feet wide with a vertical clearance of 15 feet to ensure that it is accessible by emergency vehicles.



Figure 17: Revit Rendering of Design House and Surrounding Property

The weather conditions for the fire scenario were based on average weather conditions for Sacramento, California from May to October, which is considered peak wildfire season. Sacramento was chosen because it is towards the center on a map of general locations of major fires burning in California in 2018<sup>93</sup>. Based on average weather data, the outside temperature in our scenario will be 86° F (303.15 K)<sup>94</sup>. Based on fire weather for Sacramento, the air will have a relative humidity of 30%<sup>95</sup> and a wind speed of 10-15mph which was commonly used in similar studies.

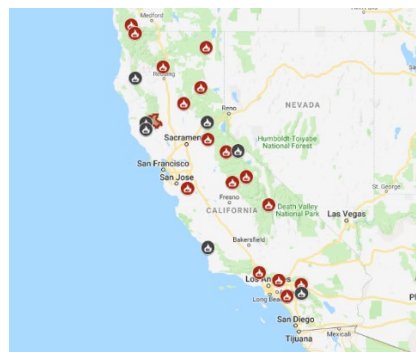


Figure 18: Wildfires in California<sup>96</sup>

<sup>93</sup> California Statewide Fire Map, (2018)

<sup>94</sup> October in Sacramento, (2018)

<sup>95</sup> California Fire Weather, (2018)

<sup>96</sup> California Statewide Fire Map, (2018)

### 5.3 Trees

Ponderosa pine, *pinus ponderosa*, is one of the most common trees found in California, and are easily recognized for their tall, thick trunks, covered in orange bark. However, in the event of a wildfire, this bark along with their thick pine needles, have been known to turn into smoldering embers that are carried by the wind<sup>97</sup>. For these reasons, ponderosa pine was chosen as the wood species for the firebrands for this study.

Standing anywhere between 60 to 130 feet tall, ponderosa pine is one of the tallest trees in the Southwest region of the United States. It also has a wide trunk that ranges from 30 to 60 inches in diameter. Ponderosa pine trees are usually found in mountain ranges and grow best in climates with a moderate amount of rainfall and elevations ranging from 3,000 to 9,000 feet<sup>98</sup>.



Figure 19: *Pinus ponderosa*

---

<sup>97</sup> *Ponderosa Pine*, (2015)

<sup>98</sup> *Ibid.*

## 6 Simulation of Accumulation of Firebrands

As stated in the methodology, a potential trial design is evaluated from a developed fire scenario. Trial designs incorporate all components of the fire protection system to combat the fire scenario and reduce the threat. To begin with, the fire scenario was simulated advanced software in order to learn the critical aspects of firebrand transport, accumulation, and ignition. By using software to understand the threat to the structure, a system can be developed to then adequately address it to limit any further damage. It was important to model the design fire to gain a greater understanding of the threat profile.

### 6.1 Simulating the FDS Scenario

Different aspects of the fire scenario were modeled in NIST's Fire Dynamics Simulator (FDS), a computational fluid dynamics (CFD) model of fire driven fluid flow. FDS is a Fortran program that reads input parameters from a text file, computes a numerical solution to the governing equations, and writes user-specified output data to files<sup>99</sup>. The program employs principals of computational fluid dynamics in order to numerically solve a large simulation of the Navier-Stokes equations appropriate for low-speed, thermally driven flow, of a design fire and suppression system, with an emphasis on smoke and heat transport from fires to describe the evolution of the fire<sup>100</sup>.

For our scenario in within FDS, there are two main design areas of focus. The first is to create a realistic and replicable representation of firebrands. The second area of focus is on our design house and environment, which will demonstrate the benefits and weaknesses of an average house in the WUI. The intent behind the scenarios was to create a replicable interaction between firebrands, the wind, and the house. From this point, an appropriate firefighting system can be developed to understanding the geometries.

#### 6.1.1 FDS Background

All FDS calculations was performed within a domain that is made up of rectilinear volumes called meshes. Each mesh was divided into rectangular cells, the number of which depends on the desired resolution<sup>101</sup>. Each cell was calculated individually, depending on the inputs of both the content and properties within a cell and the influence of surrounding cells. Each cell was assigned to an individual process on a computer, directly tying computational time to the number of cores assigned to the calculation and the time it takes for the resultant calculations to be saved and communicated to other cells per time step. The mesh size was not uniform throughout the model in order to speed up calculation times.

When modeling this scenario in FDS, a variety of mesh sizes were specified throughout the model, depending on the complexity and what was trying to be accomplished. When the file

---

<sup>99</sup> Fire Dynamics Simulator User Guide

<sup>100</sup> Ibid.

<sup>101</sup> Ibid.

for the first simulations was first created, the model was run using a relatively coarse mesh for speed purposes to the detriment of accuracy.

For environmental characteristics, the ambient temperature (the temperature of everything at the start of the simulation) and weather conditions for our model scenario as defined in the Fire Scenarios section were input using the MISC parameter, for example, the input line

```
&MISC TMPA=30. /
```

The default ambient temperature is usually 20°C, however this study had it set to 30°C. The ambient pressure was set to the default of 101325 Pa to represent 1 atmosphere.

### 6.1.2 Detailed Properties of Solid Particles

For the FDS model, it was necessary to have output properties of a single solid particle using a DEVC (device) line. For example, the lines:

```
&INIT ID=a particle', PART_ID='...', XB=..., N_PARTICLES=1 /
```

```
&DEVC ID='...', INIT_ID=my particle', QUANTITY='WALL  
TEMPERATURE' /
```

output the surface wall temperature of a single particle that has been introduced into the simulation via an INIT line. One form of modeling that was considered but not employed was sourced from an FDS Particle Validation Method. Instead of representing large groups of firebrands by many particles, one potential process could be to pre-place or specify the rate of particles in the corner where the siding and the deck meet. The pine needles test case described in the FDS User Guide Section 18.4.6 used a small number of particles to represent a larger grouping or configuration of burning vegetation. Different shapes are available and as the item burns, there are various bioproducts that create new shapes. Conversely, FDS cannot merge two smaller particles to equal one larger particle. This simplification would have proven useful for modeling firebrand accumulation patterns based on the defined distribution and transportation, however the simulation did not have that capability.

### 6.1.8 Creating Obstructions in FDS

The OBST command in FDS contains parameters used to define obstructions. The entire geometry of the model, specifically the house, is made up entirely of rectangular solids, each one introduced on a single line in the input file.

Each OBST line contains the coordinates of a rectangular solid within the flow domain. This solid is defined by two points (x1,y1,z1) and (x2,y2,z2) that are entered on the OBST line in terms of the real sextuplet XB. In addition to the coordinates, the boundary conditions for the obstruction can be specified with the parameter SURF\_ID, which designates which surface to apply at the surface of the obstruction. For instance, the house walls presented the following obstructions:

```
&OBST ID=wall1', XB=-13.987911,-3.245556,1.148659,1.263195,0.0,3.1,  
SURF_ID=Siding' /
```

```
&OBST ID='wall2', XB=-13.987911,-3.245556,-9.451341,-9.336805,0.0,3.1,  
SURF_ID='Siding'/
```

```
&OBST ID='wall3', XB=-3.359903,-3.245556,-9.451341,1.263195,0.0,3.1,  
SURF_ID='Siding'/
```

```
&OBST ID='wall4', XB=-13.989903,-13.875556,-9.451341,1.263195,0.0,3.1,  
SURF_ID='Siding'/
```

```
&OBST ID='AcDb3dSolid - C4', XB=-14.25,-14.125,-  
9.625,1.375,2.91525,3.2955, RGB=0,204,204, SURF_ID='Roof'/
```

```
&OBST ID='AcDb3dSolid - C4', XB=-14.25,-3.0,-9.75,-9.625,2.91525,3.2955,  
RGB=0,204,204, SURF_ID='Roof'/
```

```
&OBST ID='AcDb3dSolid - C4', XB=-14.25,-3.0,1.375,1.5,2.91525,3.2955,  
RGB=0,204,204, SURF_ID='Roof'/
```

```
&OBST ID='AcDb3dSolid - C4', XB=-14.125,-13.875,-  
9.375,1.125,3.042,3.42225, RGB=0,204,204, SURF_ID='Roof'/
```

The system visualized flow patterns by creating Slices, which are planar data files that show properties over time, such as temperature, gas flow, or any other desirable variable defined within the simulation. The following simulation files all had slices which recorded data. Of interest was corner accumulation, heat flux, and temperature. Slices were placed perpendicular to the orientation of the target wall of the house in order to understand the interaction of wind driven firebrands and the corner.

To monitor the accumulation of solid particles that have fallen on a solid surface, a volume integral was used to understand the change in mass per unit volume in the control area throughout a simulation. Example FDS input lines are as follows:

```
&DEVC ID='Mass_VOLUME INTEGRAL', QUANTITY='MPUV',  
PART_ID='rods', STATISTICS='VOLUME INTEGRAL', XB=-20.0,6.0,-  
10.0,2.0,0.0,6.3375/
```

```
&DEVC ID='Mass01_VOLUME INTEGRAL', QUANTITY='MPUV',  
PART_ID='rods', STATISTICS='VOLUME INTEGRAL ', XB=-3.25,1.5,-  
9.75,1.5,0.0,0.507/
```

### 6.1.3 Wind in FDS

One of the key environmental areas of interest was the effect of wind. Wind plays a key role in the transportation of firebrands after they have been lofted from a fire plume. There are three ways to model wind in FDS<sup>102</sup>. The first is the Monin-Obukhov similarity which creates a wind profile that varies over the height, but it has an unstable profile that is strongly influenced

---

<sup>102</sup> Fire Dynamics Simulator User Guide

by buoyancy generated turbulence (plumes). The second is a uniform horizontal forcing function that allows the wind to develop naturally, and the third is just a “wall of wind” which is the least preferred by the FDS User Guide. For the purpose of this project, the Monin-Obukhov method where the default wind height of the wind profile is 2m. For some of the smaller scale tests, the overall height of the wind profile was lowered.

One limitation of modeling wind in FDS is that there is no sense of “indoor” or “outdoor” because there are only grid cells that are solid or not solid. Thus, a wind field will be induced everywhere in the computational domain and only a region of the flow domain from the domain from the wind may be omitted. This could be accomplished through using the HOLE function, to block the wind from a given volume. The HOLE function was not used in the simulation but could have been appropriate in the area behind a slice of the wall that would be considered indoors, and therefore would not be expected to be subject to the wind profile.

## 6.2 Firebrands in FDS

Firebrands have already been modeled in FDS in several unique applications. The NIST Dragon is a standardized test bench used in experimental studies to represent a firebrand attack. Likewise, there is a replication of the Dragon within FDS. FDS User Guide Section 18.4.7 describes both the experiment and FDS model. It states that “700 g of small dowels (length 50 mm, diameter 8 mm) made of Ponderosa Pine were poured into a small steel chamber equipped with several propane burners. The dowels were left to burn for roughly a minute subject to a slow induced air flow after which time the air flow was increased and firebrands were propelled horizontally out of a 15 cm duct 2.25 m above the lab floor. It is reported that after several replicate experiments, the average mass of the firebrands collected from pans on the floor was 57 g, average diameter was 5.6 mm, and the average length was 13.5 mm. It is not possible to simulate the experiment in FDS exactly as it was performed because in the experiment, all 700 g of the wooden dowels were poured into the heating chamber at once. FDS cannot handle such a dense packing of Lagrangian particles. Instead, the simulated dowels are introduced at a rate of 10 per second. FDS also does not have a mechanism to break-up the dowels, reducing their length from 50 mm to 13.5 mm. Thus, the initial cylindrical particles are 13.5 mm and remain that length throughout the simulation. The diameter of the cylindrical particles is reduced, however, from 8 mm to 5.6 mm, which takes the initial density of 440 kg/m<sup>3</sup> down to 71 kg/m<sup>3</sup> because the mass of the firebrands is assumed to be 8 % of the original. The amount expected on the floor is approximately 0.024 kg.<sup>103</sup>

Overall, particles can be introduced into FDS in three different ways. According to the FDS User Guide, the first way is to define a sprinkler or nozzle using a PROP line that includes a PART\_ID that specifies the particle or droplet parameters. The second way is to add a PART\_ID to a SURF line, in which case particles or droplets will be ejected from that surface. This method only works if the surface has a normal velocity pointing into the flow domain. The third way to introduce particles or droplets is via an INIT line that defines a volume within the computational domain in which the particles/droplets are to be introduced initially and/or periodically in time.

---

<sup>103</sup> Manzello & Suzuki, *Experimentally Simulating Continuous Wind Driven Firebrand Showers in Wildland-Urban Interface Fires*, (2013)

The particles in the NIST Dragon simulation are introduced into the equation through the third method of using the INIT command. The brands are then exposed to the representative propane fire and launched out of the steel tube. Another study used similar methodology with trees to simulate a fire line which was useful in understanding modeling firebrand distribution<sup>104</sup>. While the FDS file itself is not in the public domain, the concepts can be employed to model the firebrand flux and distribution on our own house. By assigning trees to have a set heat release rate, the upward velocity can be used in conjunction with the wind to launch the particles towards the house. The same holds true for actual firebrands. This method may be superior as it is more adequate for the scale of our fire scenario. The criteria for firebrands can be used from the dragon\_5a FDS file, which were as follows:

```

&SURF ID      = 'brand'
MATL_ID       = 'wood', 'moisture'
MATL_MASS_FRACTION(1,1:2) = 0.9,0.1
EXTERNAL_FLUX = 50.
THICKNESS     = 0.004
LENGTH        = 0.0135
GEOMETRY      = 'CYLINDRICAL' /

&MATL ID      = 'wood'
DENSITY       = 440.
CONDUCTIVITY  = 0.1
SPECIFIC_HEAT = 1.0
N_REACTIONS   = 1
REFERENCE_TEMPERATURE = 300.
NU_MATL       = 0.08
MATL_ID       = 'char'
NU_SPEC       = 0.92
SPEC_ID       = 'CELLULOSE'

```

---

<sup>104</sup> Sikanen, *An Innovative Approach of Integrated Wildland Fire Management Regulating the Wildfire Problem by the Wise Use of Fire*, (2006)



*HEAT\_OF\_COMBUSTION = 15000.*

*HEAT\_OF\_REACTION = 1000. /*

*&MATL ID = 'char'*

*DENSITY = 71.*

*CONDUCTIVITY = 0.1*

*SPECIFIC\_HEAT = 1.0 /*

One shortcoming of the above criteria is that it does not address the moisture content of the wood. Therefore, the material of moisture will also need to be added and is as follows:

*&MATL ID = 'moisture'*

*DENSITY = 1000.*

*CONDUCTIVITY = 0.1*

*SPECIFIC\_HEAT = 4.184*

*N\_REACTIONS = 1*

*REFERENCE\_TEMPERATURE = 100.*

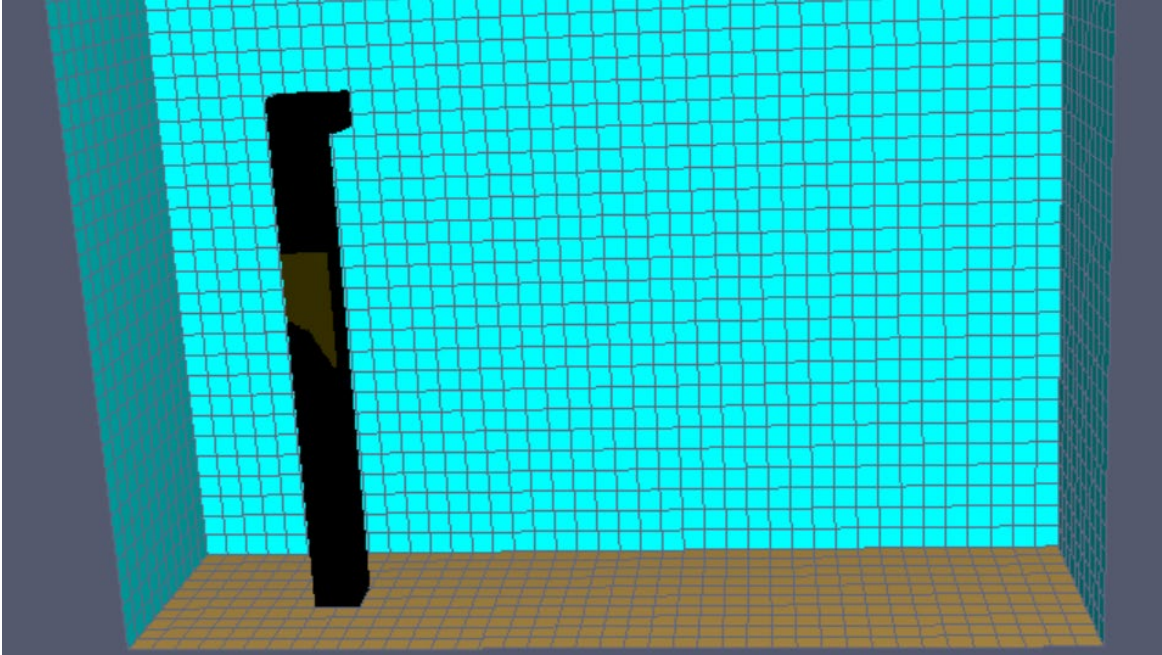
*NU\_SPEC = 1.0*

*SPEC\_ID = 'WATER VAPOR'*

*HEAT\_OF\_REACTION = 2500. /*

This value was determined based on the experimental observations of Manzello et al 2007 (Manzello, Maranghides, & Mell, 2007). It is on the lowest end of moisture content in wood. As the firebrands burn, they convert to char and subsequently lose both mass and heat energy as a result of their properties.

The first firebrand scenario run was a NIST provided Dragon example fire to understand how accurately their own simulation mirrors the laboratory setup. As seen in Figure 20, the scenario used a pipe with both a plane inserting particles and a wind profile in addition to a flame source. This setup essentially heats and ejects the particles from the pipe, simulating the NIST Dragon. Observations within this trial simulation included that the distribution and transport distance of the particles was low.



*Figure 20: Capture of the FDS Run of the NIST Dragon*

The delivery method was not efficient enough to model over the entire side of a house, let alone an entire house. This method was also computationally expensive in order to get the intended design fire, as many of the Dragon pipes would need to be modeled simultaneously. It was observed that particles would travel a maximum of 1.5 m from the base of the Dragon to the ground surface without the influence of wind. Another issue at this point hinged on the insertion interval of particles. Within the Dragon, particle insertion was well defined by experimental criteria, i.e. 200 grams of particles over a two-minute period. The INT insertion method over the top of the computational domain was considered for use in future runs. The Dragon model, while a baseline for how firebrands could be introduced into a scenario and act accordingly, was still only an abstract representation of a laboratory experiment, which is itself only a representation of firebrands from wildfires. In effect, the Dragon in FDS was too far removed from reality to be employed in the fire scenario without considering other options, such as alternative particle insertion methods.

### 6.3 The House in FDS

The house was modeled in FDS by importing a CAD drawing of the design into PyroSim. This object is then assigned material properties on each face and component. For the purpose of the simulation, it is important to determine the specific physical properties of the house in order to set performance criteria for ignition. The density, specific heat, conductivity, and emissivity of each solid object is determined in the following table. Density is the amount of fluid mass inside a volume [ $\text{kg}/\text{m}^3$ ]. Specific heat or thermal capacity,  $c$ , is the amount of energy required to cause the temperature to increase by 1 K or  $1^\circ\text{C}$  in 1kg of the material [ $\text{kJ}/\text{kg}\cdot\text{K}$ ]. Conductivity is the proportionality between the heat flux and the spatial derivative of

temperature [W/m<sup>2</sup>\*K]. Emissivity is the ratio of the actual spectral intensity of radiation emitted by a surface to the blackbody spectral intensity. Since emissivity is a ratio, it is unitless<sup>105</sup>.

These values are for when the temperature is 25 degrees Celsius, slightly lower than the temperature in this scenario. The deck was constructed with redwood which has a density of 510 kg/m<sup>3</sup>, a specific heat of 1.76 kJ/kg\*K a conductivity of 0.26 W/m\*K and an emissivity of 0.84. The concrete shingles for the roof has a density of 2370 kg/m<sup>3</sup>, a specific heat of 0.88 kJ/kg\*K, a conductivity ranging from 0.4-0.7 and an emissivity of 0.63. The siding of the house is made from fiber cement which was found to have a density of 1770 kg/m<sup>3</sup>, a specific heat of 0.84 kJ/kg\*K, a conductivity of 0.245 W/m\*K and cement has an emissivity of 0.54. When the windows were added to the simulation, tempered glass was found to have a density of 2270 kg/m<sup>3</sup>, a specific heat of 1.16, a conductivity of 5.9 and an emissivity of 0.84 when uncoated. For comparison, brick has a density of around 1765 kg/m<sup>3</sup>, a specific heat of 0.20 kJ/kg\*K, a thermal conductivity of 0.8, and an emissivity of 0.93<sup>106</sup>.

All the materials used in the FDS model were assumed to have the default value for the absorption coefficient,  $k$ , which is 5.0E4 1/m. the absorption coefficient is useful when the radiative energy transport theory must be used to describe the local state of a gas at various locations. Due to the mathematical complexity of these calculations, all the radiation parameters are assumed to be wavelength independent, therefore the absorptions coefficients represent the average properties over the whole spectrum of wavelengths<sup>107</sup>.

$$I_d = I_o e^{-k/d}$$

---

<sup>105</sup> Hurley, *SFPE Handbook of Fire Protection Engineering*, (2016)

<sup>106</sup> Wood, *Panel and Structural Timber Properties - Mechanical Properties*

<sup>107</sup> Hurley, *SFPE Handbook*, (2016)

Material	Density (kg/m <sup>3</sup> )	Specific Heat (kJ/(kg*K))	Conductivity (W/(m*K))	Emissivity
Redwood	510 <sup>108</sup>	1.76 <sup>109</sup>	0.26 <sup>110</sup>	0.84 <sup>111</sup>
Concrete shingles	2370 <sup>112</sup>	0.88 <sup>113</sup>	0.4-0.7 <sup>114</sup>	0.63 <sup>115</sup>
Fiber cement siding	1770 <sup>116</sup>	0.84 <sup>117</sup>	0.245	0.54 <sup>118</sup>
Tempered Glass	2270 <sup>119</sup>	1.16 <sup>120</sup>	5.9 <sup>121</sup>	0.84 (uncoated) <sup>122</sup>

Table 2: FDS Material Properties

By using the values in Table 2 on each obstruction, the model is then converted into blocks equivalent to the mesh density within the program. While this may not directly represent reality, the blocks summarize the interactions materials will have in the scenario accurately enough. From there, environmental factors will be added into the scenario.

The dimensions of the model home are 35' by 35' and it has two floors with a height of 10', making the building about 2,500 sq-ft. Environmental factors include wind speed, relative humidity, temperature, and pressure. As stated in the fire scenario based on average weather data from Sacramento California during wildfire season, the outside temperature in our scenario will be 86° F (303.15 K)<sup>123</sup>, and a relative humidity of 30%. The wind speed of 10-15mph which was chosen because it was the value commonly used in similar studies.

## 6.4 Overview of Fire Scenario

Seven different FDS runs were tested in order to understand how well the program can model the design fire and environment. All relevant FDS source code is located in Appendix B. The first run was described in Section 6.2. The second scenario placed the NIST Dragon in the

<sup>108</sup> *Pine/Redwood (Pinus silvestris)*

<sup>109</sup> *Thermodynamics: Heat and Enthalpy*

<sup>110</sup> *Pine/Redwood (Pinus silvestris)*

<sup>111</sup> *Emissivity Values for Common Materials*

<sup>112</sup> *Density of Some Common Building Materials*

<sup>113</sup> *Specific Heat of Common Substances*

<sup>114</sup> *Thermal Conductivity of common Materials and Gases*

<sup>115</sup> *Emissivity Coefficients Materials*

<sup>116</sup> *CSI Specifications, (2018)*

<sup>117</sup> *Ibid.*

<sup>118</sup> *Emissivity Table*

<sup>119</sup> *Weight of Tempered Glass*

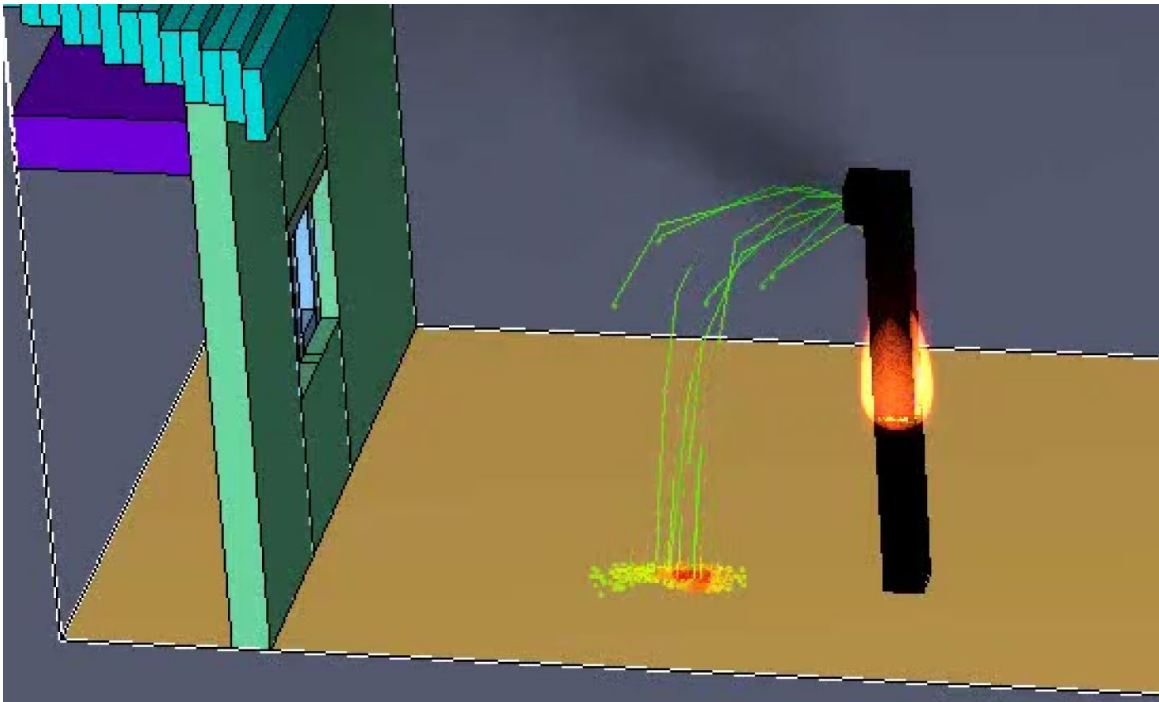
<sup>120</sup> *Glass Physical Properties*

<sup>121</sup> *Ibid.*

<sup>122</sup> *Ibid.*

<sup>123</sup> *October in Sacramento, (2018)*

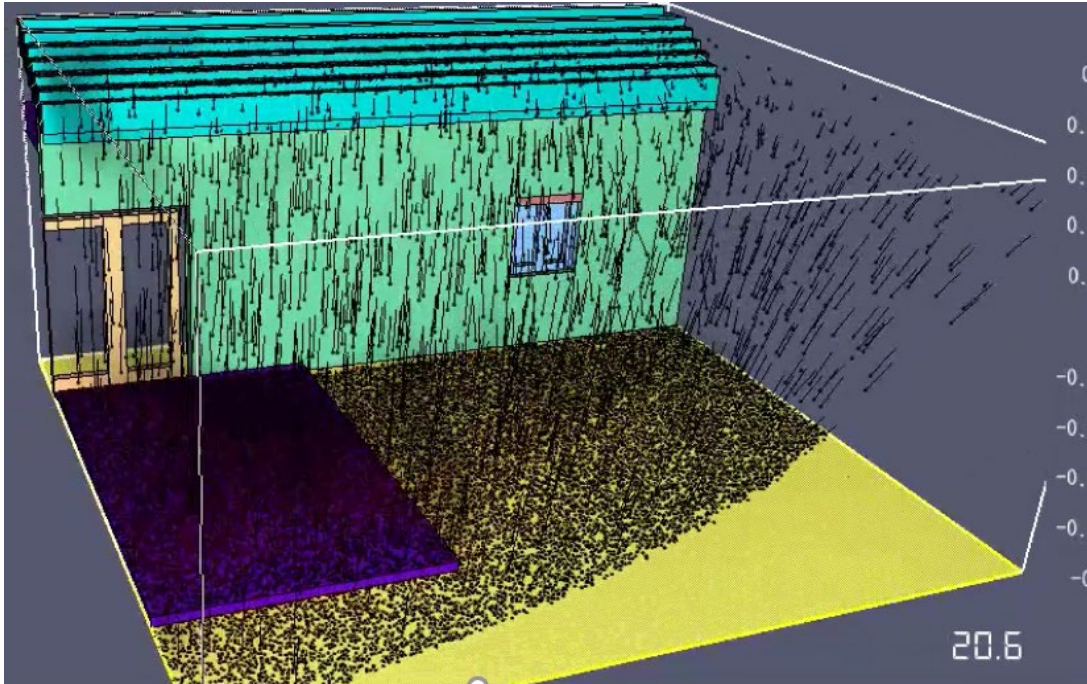
same environment as the imported house CAD file. As seen in Figure 21, the firebrands did not reach the house, and largely cluster 1.5 m from the Dragon, even with the influence of wind added into the simulation.



*Figure 21: Capture of the FDS Run of the NIST Dragon with House*

Once it was determined that the confines of a pipe would not be enough for efficiently introducing a flux of firebrand particles into the scenario, an entire particle cloud was defined by the INT line. Figure 21 displays how the slanted roof is represented by blocks within the cells of FDS. The number of blocks is correlated to cell size. There is currently no way to model slants in FDS. The firebrands are derived from the NIST Dragon example. They are cylinders of ponderosa pine, burning and decreasing in radius. The firebrand material has a specific heat of 1, a conductivity of 0.1, a density of 440, a heat of combustion of 1.5E4 kJ/kg. The reaction produces char.

The next iteration of FDS design is represented in Figure 22, which displays firebrands being generated from a plane at the top of the scenario. The influence of wind can be observed by the lack of firebrands on the bottom right hand side of the figure. The wind blew directly towards the house, perpendicular to the wall.



*Figure 22: Capture of the FDS Run with Firebrand Particle Cloud*

Figures 23, 24, and 25 display a model with the entire house, a larger deck, and overall yard. This setup contained a high number of cells. As a result, different grid resolutions were used on the extraneous areas to still incorporate the insertion of particles and wind into the scenario while using fewer resources. The top, bottom, and right middle meshes are 0.25 x 0.25 m. The middle-left mesh with the house is more detailed at 0.125 x 0.125 m. The brands were introduced in a particle cloud over the entire area of the simulation at a height of 6.3m (above the roof of the house) at a flux of 1 particle per square meter/second. The simulation ran for 8 minutes due to computational time constraints. The FDS simulation, even after running on a complex cluster which utilized multiple cores, was too computationally intensive as thousands of further particles were inserted into the scenario, slowing down further and further over each time step. This simulation was important in understand how particles would flow around the entire house. Prior simulations only dealt with a portion of the structure. However, the simulation did not effectively model the micro-corner accumulation that resulting simulations were run to determine.

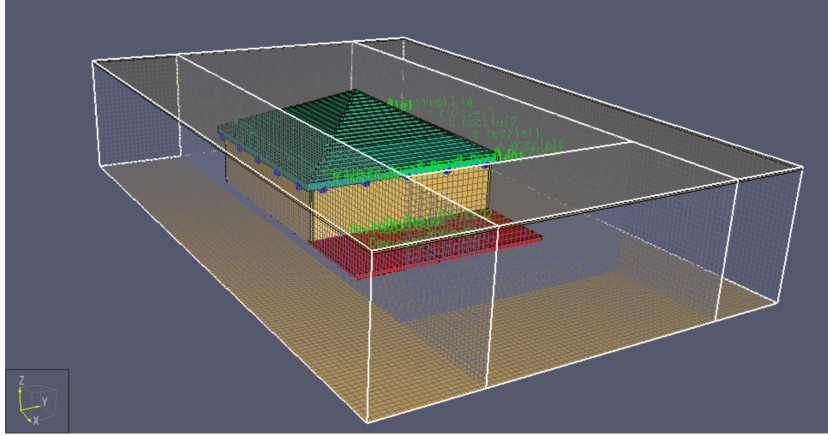


Figure 23: Capture of the FDS Input Profile for the Entire House

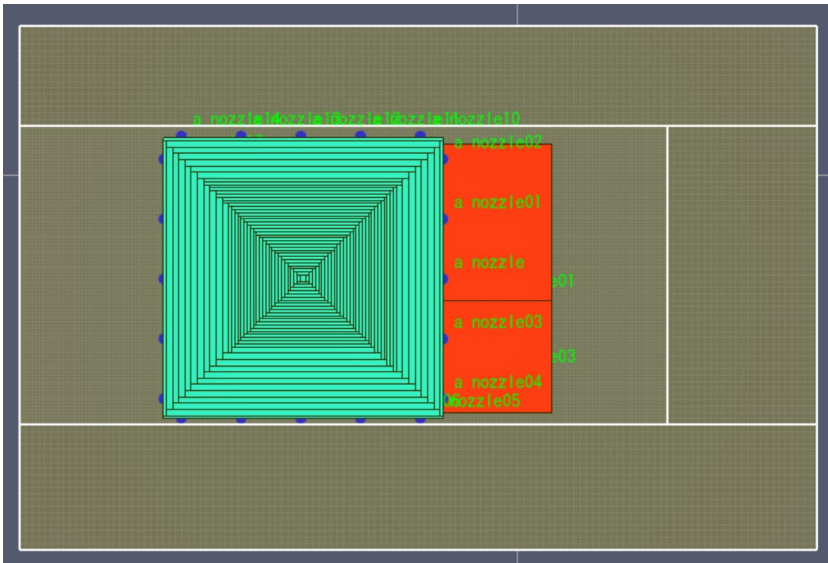


Figure 24: Capture of the FDS Input Profile for the Entire House, Top View

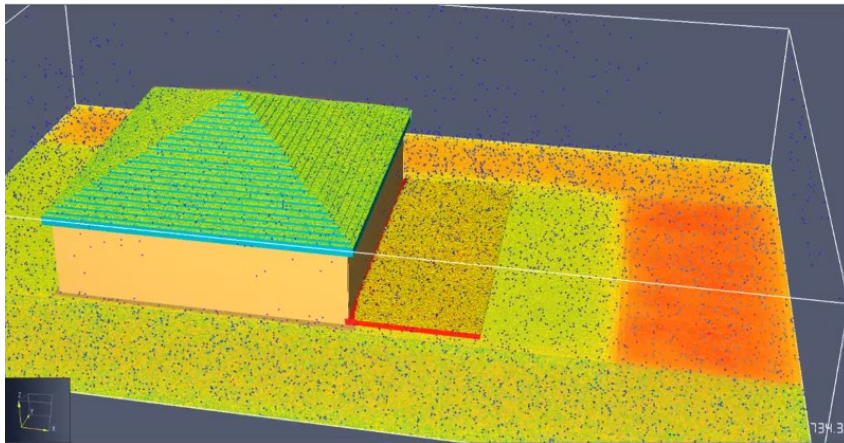


Figure 25: Capture of the FDS Results for the Entire House

Figure 26 demonstrates the effect of the wind profile over the wall towards the corner. As the wind hits the side of the house, the velocity decreases considerably, and firebrands are deposited against the wall, failing to the corner in addition to those blown into the corner horizontally. One disadvantage of FDS is the inability for it to adequately model friction over surfaces. There is simply no input for it. This is relevant because firebrands not only have the effect of wind as a factor of their location, but the coefficient of friction over their porous surfaces interacting with either the deck or siding of the house.

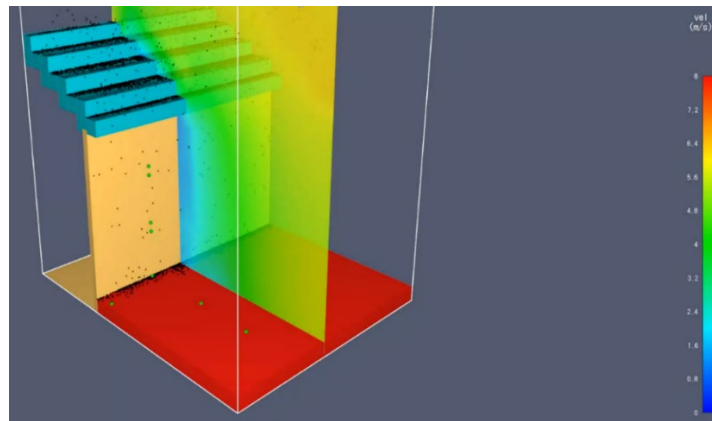


Figure 26: Capture of the FDS Results with Wind Profile

Figure 27 exhibits how accumulation within FDS cannot show the volumetric relationship particles have with one another. For this run, the particles were increased in size to equal the grid size of 0.125 m. Particle generation was also increased to 10 particles per square meter per second. This still resulted in accumulation that was similar to the original design dimensions. The physical size of the particles had no effect on their placement. As a result, the accumulation may be considered realistic in the X and Y planes, but not the Z plane. Additionally, the complex insulating component of firebrand accumulation is not accurately modeled for this reason. This test was critical in determining a limitation within FDS, and is discussed in Chapter 9 of this report.

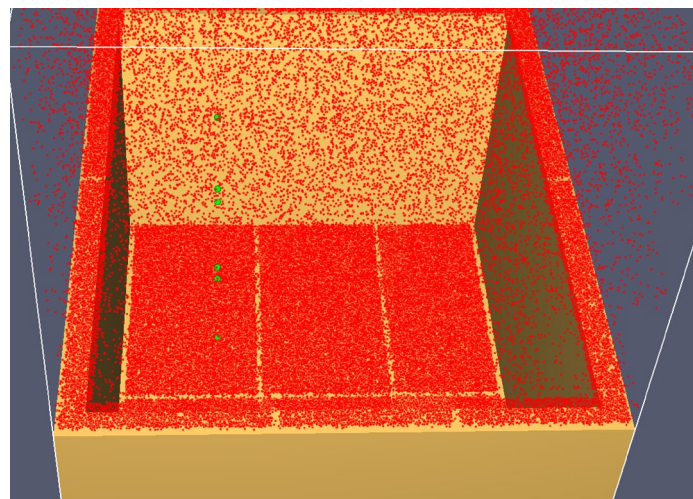


Figure 27: Test of Large Particle Accumulation



Figure 28 displays the side profile of firebrands entering into a 1 x 1 m design area with a constant, simplified wind velocity. All of the firebrands flowed with the direction of the wind. PyroSim results displayed an animation that a fire had occurred in the corner between the deck and the siding. This test was the final iteration of testing firebrands with the influence of a structure in FDS and set the stage for the desired water spray geometry in Chapter 7 of this report. Of note, it was important to cover the entire design area of 1m out from the house in addition to the walls.

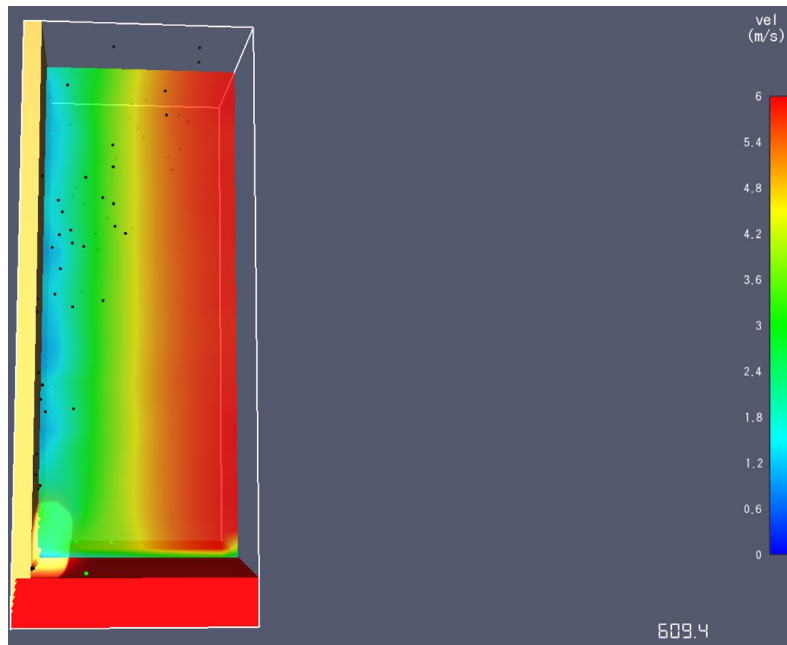


Figure 28: Capture of the FDS Results for Small Design Area

#### 6.4.1 Water Spray in FDS

A sprinkler or nozzle is added to the simulation using a PROP line to describe the features of the device and a DEVC line to position and orient the device within the computational domain. PARTICLES\_PER\_SECOND is the number of droplets inserted every second per active sprinkler or nozzle (Default 5000). It is listed on the PROP line that includes other properties of the sprinkler or nozzle. Note that this parameter only affects sprinklers and nozzles. Changing this parameter does not change the flow rate, but rather the number of droplets used to represent the flow. In order to appropriately model the water spray in FDS, there are three principal aspects of the program which need to be examined. The first is akin to introducing firebrand particles in the scenario. The three distribution methods still exist as options, however in this case using a nozzle will obviously be more appropriate. The particles will be represented as liquid droplets. Per the User Guide, if SPEC\_ID='WATER VAPOR' the droplets are not only assigned the thermo-physical properties of water, but also the radiation absorption properties are set to that of water, and the droplets are colored blue in Smokeview. This is all acceptable for our scenario. By using a nozzle, it is important to specify particles per second. The default is 5000.

FDS also has two other factors for firefighting with water. The first is tracking water along a solid surface. When a particle hits a horizontal solid, it will spread in a random manner. When it hits a vertical surface, it will travel down the surface. This has implications for our firebrands, as they are cylinders moving through the air and will have complex interactions with the water spray. It is important to pay attention to this interaction. The final factor is predicting the reduction in burning rate. Water reduces the fuel pyrolysis rate by cooling the fuel surface and changes the chemical reactions that liberates fuel gases from the solid<sup>124</sup>. As our fuel has been given reaction parameters via the MATL line, there is no need to set any additional parameters.

The program models extinction by determining a critical flame temperature through determining the fuel and oxygen content of a given grid cell. This mode is not the default option in the program and will need to be set. When a cell reaches a given temperature, has the correct fuel content, and is exposed to oxygen above a critical flame temperature, it is assumed combustion will occur<sup>125</sup>

---

<sup>124</sup> Iqbal Mahmud, *Experimental and numerical study of high-pressure water-mist nozzle sprays*, (2016)

<sup>125</sup> AbdRabbo, Ayoub, Ibrahim, & Sharaf, *Study the Properties of Water Mist Droplet by Using FDS*, (2016)

## 7 System Design

### 7.1 Detection

NFPA 72, the *National Fire Alarm and Signaling Code* addresses means of detection available for consideration for system activation. The application for the system is unique, as it is critical for the firebrands and the resulting fire to be detected outside of the house, in an open-air environment. Therefore, common compartment fire detection devices will not be as effective. This includes heat-sensing fire detectors, which the SFPE Handbook of Fire Protection Engineering argues primarily function by detecting convective heat. In our given environmental scenario, the turbulent air does not lend itself to detecting a fire in the corner of the house easily. The second option is smoke detectors. NFPA 72 Section 17.7.1.8 states that “unless specifically designed and listed for the expected conditions, smoke detectors shall not be installed if ...air velocity (is) greater than 300 ft/min (1.5 m/sec)”. For our scenario, again the wind speed is too high for smoke detectors to be effective in detecting smoke from a firebrand-initiated fire early on. In an open air, windy environment, these detectors would be ineffective.

This leads the focus towards radiant energy-sensing fire detectors. NFPA 72 Section 17.8.2.2 lists valid concerns for utilizing this method of detection, which includes matching the spectral response of the detector to the spectral emissions of the fire or fires to be detected and minimizing the possibility of spurious nuisance alarms from non-fire sources inherent to the hazard area. Simply put, radiant energy-sensing fire detectors have some inherent drawbacks. For instance, the SFPE Handbook states that radiant energy detection only occurs in one of three bands, ultraviolet, visible, or infrared. The sun presents a potential source of a nuisance or false alarm on the infrared spectrum. These drawbacks are addressed in Figure 29 and are discussed within Chapter 9. For the house, even a reflection off the windows can introduce a false alarm on this spectrum. This can be counteracted by selecting either an ultraviolet or IR/UV combination detector for the application. Another important consideration is that a radiant energy-sensing fire detector is a line-of-sight based detection device. This means that all detectors have a given field of view and range. This information is provided by manufactures in listed applications and can be selected for our given scenario.

NFPA 72 Section 17.8.3.2.1 specifies that the location and spacing of detectors shall be the result of an evaluation which includes the following information:

1. Size of the fire that is to be detected
2. Fuel involved
3. Sensitivity of the detector
4. Field of view of the detector
5. Distance between the fire and the detector
6. Radiant energy absorption of the atmosphere
7. Presence of extraneous sources of radiant emissions
8. Purpose of the detection system
9. Response time required.

All of these criteria are applicable to any radiant energy heat detector and can be applied towards the firebrand fire detection system design. Another significant factor is cost for performance of the detector. While the intent of NFPA 72 is to provide appropriate detection criteria for life safety, the goal of the firebrand firefighting system is property preservation. Therefore, the detection device must be cost effective. Some listed or approved detectors are designed for industrial flame detection purposes and are both robust and expensive. An example of an inexpensive but listed ultraviolet flame detector is the TAKEX America's FS-2000E. It currently retails for less than \$200 online. Another option, although not officially listed, is the TAKEX TX-124R. The system is designed for outdoor use and provides the option of a built-in battery backup<sup>126</sup>. TX-124R has 2 sensitivity settings (H or L) and 4 detection timers (1, 6, 15 or 30 sec). A combination of the two parameters provides 8 sensitivity levels which enables the sensor to fit with various environments and conditions. A desirable perimeter is for the detector to be highly sensitive when required. However, the risk of false activation still exists from the sun, reflections from windows, or even firebrands landing in an area which is not of direct threat to the property. Accidental discharge is a risk that should be examined in future work. Another important characteristic is a battery backup built into the device, which could still trigger the firefighting system in the event the home lost power. A figure of detection parameters is in Figure 29.

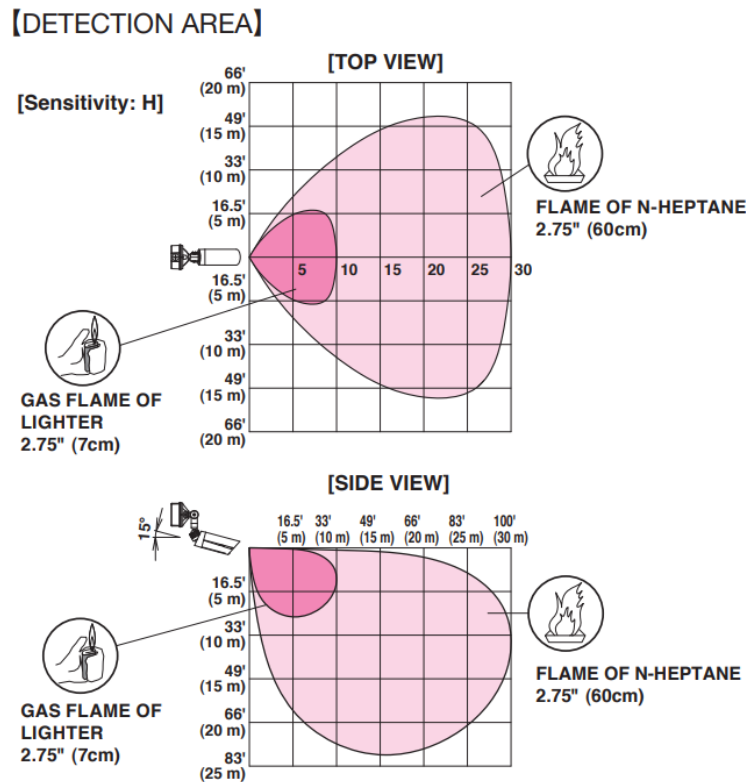


Figure 29: TAKEX America's FS-2000E flame detector<sup>127</sup>

<sup>126</sup> Security Sensors/TX-124R, (2010)

<sup>127</sup> Ibid

As seen in Figure 29, with a high sensitivity, a small flame with a height of 7 cm can be detected at a range of 33 feet with an aperture of 16.5 feet. If the flame detectors were mounted under the eaves of the house in the corners and in the middle, three detectors could be used per side of the scenario house. Detector configuration would vary per application. One critical limitation of the detector is its inability to detect smoldering combustion. The flame detector is subject to an inverse square law of fire size versus distance. Further testing will be needed to assess the sensitivity of this detector in the transition from smoldering combustion to flaming combustion.

The following figure shows a drawing of a three-detector layout in the design house. The detectors have been tilted 10 degrees to maximize the detection surface area.

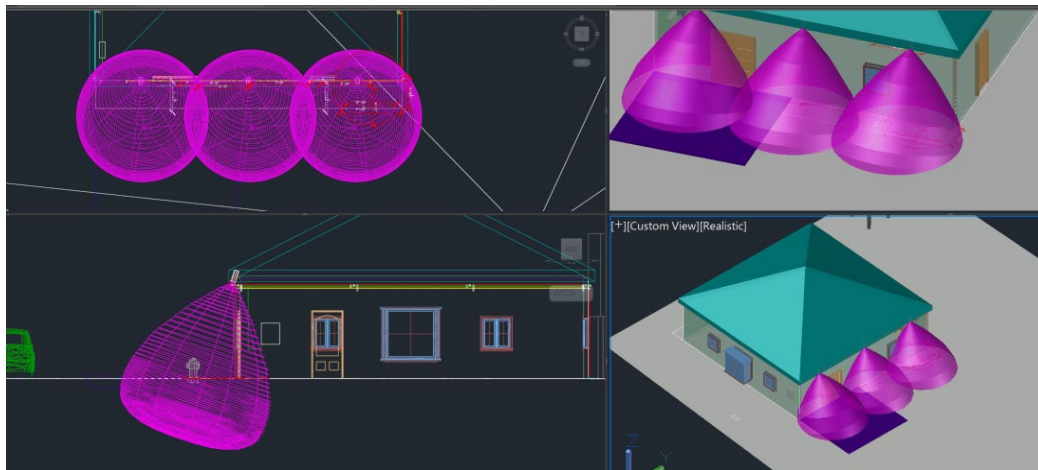


Figure 30 Layout of Detectors

Once the device detects an alarm, it sends a current to a separate transmitter, which is designed to be attached to the back. This transmitter can send a wireless signal to an alarm box or controller by using 3V transmitters and receivers, such as those offered by Schalk<sup>128</sup>. The entire detector and transmitter can be a standalone, battery powered and wireless solution.

## 7.2 Water Spray Discharge Requirements

In order to determine how much water the system should use, geometric requirements are first established from the house in the scenario. To begin with, the design area for the system is dependent on each side of the house. As simulated within FDS, accumulation in the corner served as a factor when it was within 1 m of the siding. The length of the house is 35 ft (10.67 m). The system design area per side of the house is thus 114.8 ft<sup>2</sup> (10.668 m<sup>2</sup>). The Building Research Institute's Fire Research Wind Tunnel Facility conducted a test with a NIST Dragon in which they calculated that 17.1 g/m<sup>2</sup>s was the critical firebrand flux needed to sustain flaming combustion on a wood surface with a wind speed of 6 m/s. When multiplying the critical mass of

<sup>128</sup> Radio connection system *Wireless Wire*

firebrands over the design area, the result is a firebrand accumulation rate of 182.4 g/s for flaming combustion to occur.

The total heat release rate of any fire is equivalent to the mass lost multiplied by the heat of combustion. The heat of combustion of ponderosa pine is 19.4 kJ/g<sup>129</sup>. As the given firebrand mass flux is considered critical to sustaining flaming combustion, it was assumed that the critical mass flux is equal to the mass lost. In other words, the mass lost is 182.4 g/s over the design area. This yields a heat release rate of 3539 kW.

In turn, the latent heat of vaporization of water is 2.4 kJ/g<sup>130</sup>. A safety factor of 30% was added based on the 30% area decrease reflected in NFPA 13 for dry pipe sprinkler systems, which will be discussed in Section 7.3.3.

$$\frac{3539 \text{ kJ/s}}{2.4 \text{ kJ/g}} = 1474 \frac{\text{g}}{\text{s}} \text{ water required} * 1.3 \text{ safety factor} = 1916 \frac{\text{g}}{\text{s}} = 1.9 \text{ liters/second}$$

1.9 liters of water per second equates to 30.11 gallons per minute. This is the amount of water required over the discharge area (1m = 3.28ft x 35ft = 114.8ft<sup>2</sup>). The discharge density of the system is thus 0.26 gpm/ft<sup>2</sup>. This compares to an Extra Hazard Group 1 Occupancy in NFPA 13 and will be discussed further in Chapter 8 of this report.

### 7.3 Water Spray Nozzle Selection

As was previously stated, the residential water supply especially in the event of a wildfire, is very limited and therefore the system must use as little water as possible. In order to conserve water, the selection of sprinkler model is a critical factor. It is reasonable to use a lowest K-factor, which is the formula used to calculate the discharge rate from a nozzle, with the minimum pressure and minimum flowrate needed to meet the design criteria.

To begin with, the lowest possible K-factor in residential and commercial sprinklers were examined, but such sprinklers have a K-factor of 5.6 and up. Water spray nozzles have lower values. For that reason, the analysis examined water spray systems. Water spray systems differ from commercial sprinklers as they are often used for industrial applications, such as protecting an exposure like a tank from radiant heat. The lowest K-factor values found were 1.2 -1.9 from manufacturers Viking and Reliable. These two vendor's offerings will be discussed at the end of this section as a suggestion for manufacturers. The primary reason for evaluating two different sprinkler designs was to optimize the water spray pattern in the corner of the house.

The most critical aspect of the system is to discharge water into the corner of the house. The area will be 35ft x 3.28ft = 114.8ft<sup>2</sup> as the illustrated in Figure 31:

---

<sup>129</sup> SFPE Handbook Table 5.3

<sup>130</sup> Drysdale, Dougal, An Introduction to Fire Dynamics, Section 6.6.2.

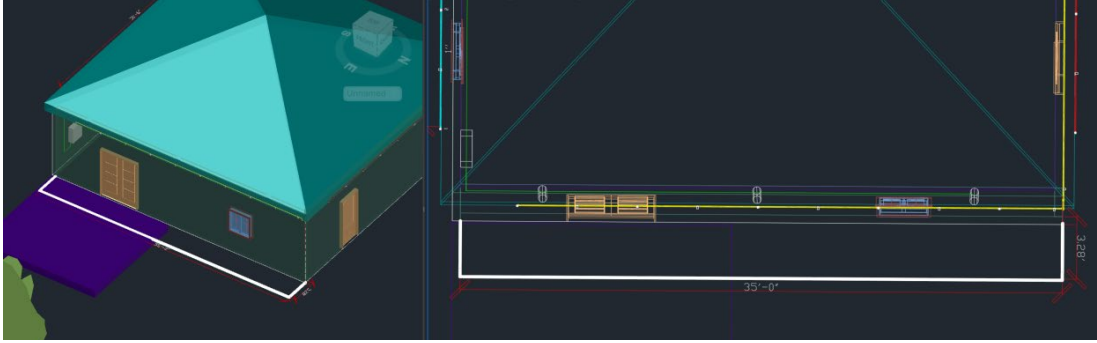


Figure 31: House Isometric and Top View in CAD.

### 7.3.1 Trial Design 1: Viking Spray Nozzle VK810

For the first trial design, a Viking Model E, VK810 spray nozzle was used<sup>131</sup>. The distance from the roof to the ground is 10 ft. The roof overhang is 8 in. A deluge sprinkler is required as environmental conditions could mean that a pipe or sprinkler exposed to the elements could freeze in some climates. The same holds true for the second trial design. The technical data guide for this nozzle is located in Appendix C.

The spray nozzle should have a spray angle of  $65^\circ$  in order to minimize the amount of water being distributed away from the house. This is the smallest nozzle angle offered by the company, as seen in Appendix C. A  $65^\circ$  nozzle would provide spray 4 feet from the nozzle centerline at an axial distance of 10 feet. With spray 4 feet from the centerline, the nozzle would cover 50.26 sqft of area. In order to receive the appropriate amount of water in the design area, 0.26 gpm/sqft multiplied by 50.26 sqft equates to 13.07 gpm per sprinkler.

At this point, five sprinklers are needed, each spaced approximately 7 ft apart per side. With all sprinklers oriented towards the ground, the radial spray pattern will be four feet. With this orientation, a 114.8 sqft uncovered space exists. Therefore, each sprinkler must be rotated towards the wall of the house by  $3^\circ$  to cover the design area sufficiently.

With a design discharge of 13 gpm, a K-factor of 2.3 would be appropriate for this application, as it offers the lowest possible pressure while still achieving documented discharge characteristics, as seen in the technical guide located in Appendix C. The design pressure for the most remote nozzle would then be 31.5 PSI.

For the most remote nozzle, the requirement of 31.95 PSI now drives the rest of system design. Figure 32 demonstrates a system design, the full drawings for which can be found in the Appendix. The follow rate needed is show in Figure 33. Full calculations are also included in the Appendix. The total water usage was 69.24 gpm at a total pressure of 70.5 PSI.

<sup>131</sup> Model E Spray Nozzle

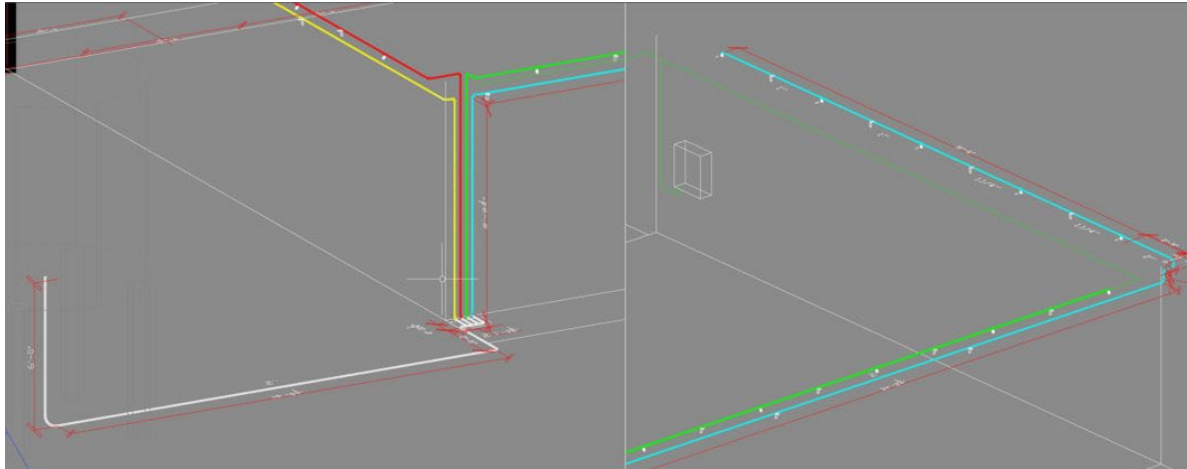


Figure 32: Viking System Design

1-2.		q		1	1E	Lgth.	7		Pt		31.95	Pt		C	120.00
		Q	13			Ftg.	2	0.074	Pe	0.0	0.00	Pv		Pt	31.95
						Tot.	9		Pf		0.67	Pn		K1	2.30
									Pt		32.61	Pt			
2		q	13.13			Lgth.			Pe			Pv			
		Q				Ftg.			Pf			Pn			
						Tot.			Pt			Pt			
2-3		q	26.13	1	1T	Lgth.	7	0.269	Pt		32.61	Pt	35.85		
		Q	26.13			Ftg.	5		Pe	0.0	0.00	Pv	0.767044		
						Tot.	12		Pf		3.23	Pn	35.08		
									Pt		35.85	Pt			
3		q	13.77			Lgth.			Pe			Pv			
		Q				Ftg.			Pf			Pn			
						Tot.			Pt			Pt			
3-4		q	39.91	1.25	1T	Lgth.	7	0.199	Pt		35.85	Pt	38.43		
		Q	39.91			Ftg.	6		Pe	0.0	0.00	Pv	0.732497		
						Tot.	13		Pf		2.59	Pn	37.70		
									Pt		38.43	Pt			
4		q	14.26			Lgth.			Pe			Pv			
		Q				Ftg.			Pf			Pn			
						Tot.			Pt			Pt			
4-5		q	54.16	1.25	1T	Lgth.	7	0.350	Pt		38.43	Pt	42.98		
		Q	54.16			Ftg.	6		Pe	0.0	0.00	Pv	1.349471		
						Tot.	13		Pf		4.55	Pn	41.63		
									Pt		42.98	Pt			
5		q	15.08			Lgth.			Pe			Pv			
		Q				Ftg.			Pf			Pn			
						Tot.			Pt			Pt			
5-Tank		q	69.24	2	10E	Lgth.	69.49	0.056	Pt		42.98	Pt	50.54		
		Q	69.24		3T	Ftg.	40.8		Pe	3.2	1.39	Pv	0.336523		
						Tot.	110.29		Pf		6.16	Pn	50.20		
											50.54				
Total															
		Q	69.24							20.0					
											P				
												70.54			

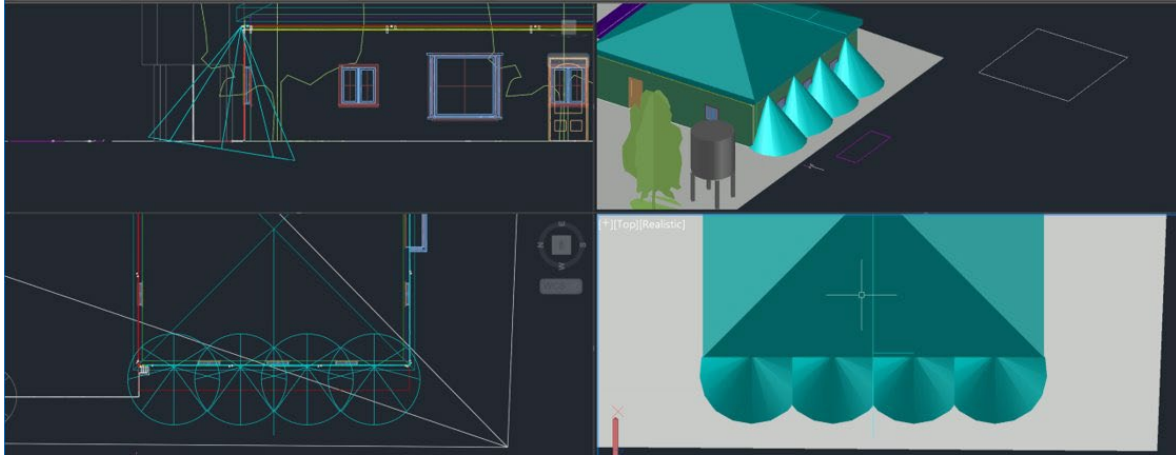
Figure 33: Hydraulic Calculations

### 7.3.1 Trial Design 2: Reliable Model R20-80

A second water spray system trial design was then calculated to compare discharge geometries, optimizing area. The Reliable Model R20-80, 80 Degree Spray Nozzle will be the same distance from the roof to the ground at 10 ft. The roof overhang is still 8 in. For this model, a K-factor of 1.9 was selected. An effective range of 10ft (axial) x 6 ft (radial), is derived from the technical data located in the Appendix.

The water spray nozzle for this application was selected to be 80° in order to minimize the amount of water being distributed away from the house. This is the smallest nozzle angle offered by the company. Figure 34 demonstrates that an 80° nozzle would provide spray 6 feet from the nozzle centerline at an axial distance of 10 feet. With spray 6 feet from the centerline, the nozzle would cover 113 sqft of area. In order to receive the appropriate amount of water in the design area, 0.26 gpm/sqft multiplied by 113 sqft equates to 29 gpm per sprinkler.

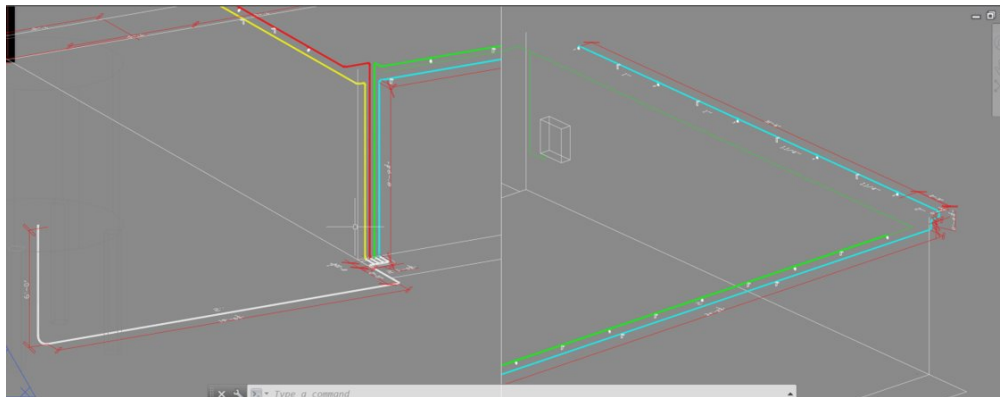




*Figure 34: Reliable Sprinkler Trial Design*

Four sprinklers spaced approximately 8.75 ft apart per side, each sprinkler toward to ground will have 4ft of radial spray pattern with an inclination of 10 degrees in order to cover the design area.

With a design discharge requirement of 29 gpm at the design sprinkler, a higher K-factor of 5.8 was selected in order to lower overall system pressure while still achieving documented discharge characteristics. The design pressure for the most remote nozzle would then be 25 PSI. The design of the system is exhibited in Figure 35. System calculations are demonstrated in Figure 36 and included in the Appendix of the report. The total water usage was 144.7 gpm at a total pressure of 109.23 PSI.



*Figure 35: Reliable System Design*

1-2.		q		1	1E	Lgth.	8.75	0.327	Pt		25.00	Pt	C	120.00	
		Q	29			Ftg.	2		Pe	0.0	0.00	Pv	Pt	25.00	
						Tot.	10.75		Pf		3.51	Pn	K1	5.80	
2		q	30.97			Lgth.			Pt		28.51	Pt			
		Q				Ftg.			Pe			Pv			
						Tot.			Pf			Pn			
2-3		q	59.97	1	1T	Lgth.	8.75	1.253	Pt		28.51	Pt		45.74	
		Q	59.97			Ftg.	5		Pe	0.0	0.00	Pv		4.038731	
						Tot.	13.75		Pf		17.22	Pn		41.70	
3		q	39.22			Lgth.			Pt		45.74	Pt			
		Q				Ftg.			Pe			Pv			
						Tot.			Pf			Pn			
3-4		q	99.19	1.25	1T	Lgth.	8.75	1.072	Pt		45.74	Pt		61.55	
		Q	99.19			Ftg.	6		Pe	0.0	0.00	Pv		4.52596	
						Tot.	14.75		Pf		15.81	Pn		57.02	
4		q	45.50			Lgth.			Pt		61.55	Pt			
		Q				Ftg.			Pe			Pv			
						Tot.			Pf			Pn			
4-Tank		q	144.70	2	10E	Lgth.	69.49	0.219	Pt		61.55	Pt		89.23	
		Q	144.70		3T	Ftg.	50.8		Pe	3.2	1.39	Pv		1.469518	
					1T	Tot.	120.29		Pf		26.29	Pn		87.76	
Total					Safety factor to use in other adtional devices				20.0			89.23			
		Q	144.70									P			
												109.23			

Figure 36: Reliable Water Spray System Calculations

After conducting two system calculations, it can be observed that the Viking system provides the same water density over the design area while using less pressure and fewer gpm.

### 7.3.3: Other System Components

For pipe selection, as the system will be located externally, it would be appropriate to use galvanized steel pipe as the galvanization process reduces the potential for corrosion<sup>132</sup>. The SFPE Handbook lists the Hazen-Williams coefficient as 120 for galvanized steel pipe<sup>133</sup>.

In summation, the system requires 69.24 gpm and 70.5 psi at the valve. Over a 30-minute discharge period, this is a water requirement of 2077 gallons of water. With all 1" pipe, the system would have required 69.24 psi at the riser. Using all 2" pipe, the system would require only 22.8 psi, however the pipe and associated material is more expensive per foot. It was determined that of the 5 sprinklers, the first two should have 1" pipe between them. The second two should have 1.5" pipe, and the fifth sprinkler can have 2" pipe all the way back to the tank. This reduces some cost in the system by adding only 6 psi to the overall system demand. In the future applications, this material selection can be further refined.

In the case of a wildfire event, it is very likely that the home does not have access to a residential water supply or there is insufficient water pressure from the main. A tank and a pump may be used as a standalone system<sup>134</sup>. A tank with capacity for 2077 gallons is needed to ensure that the home has enough water to run the system if the municipal water supply is cut off. The tank recommended for this system is a 2100-gallon water storage tank that is molded with polyethylene resin<sup>135</sup>.

<sup>132</sup> "Galvanized vs Stainless Steel Cost, Strength & Weight Differences" Wenzel Metal Spinning Accessed February 17, 2019. <https://www.wenzelmetal spinning.com/galvanized-steel-vs-stainless.html>.

<sup>133</sup> SFPE Handbook Table 42.1.

<sup>134</sup> *Understanding Water Supply for Home Fire Sprinkler Systems*, (2012)

<sup>135</sup> *2100 Gallon Norwesco Plastic Potable Water Storage Tank*



*Figure 37: Plastic Potable Water Storage Tank<sup>136</sup> and 3.5 HP Gas Powered Pump<sup>137</sup>*

In the pump and tank system, the pump can remain dormant until the event of the fire when the water spray system is activated and is needed to provide the required water flow from the tank to the sprinklers. Based on the calculations above, the system only needs a flow rate of 69.24 gpm, therefore a small gas-powered pump would be sufficient to provide enough water pressure. For example, the pump suggested for this system is a 3.5 Horsepower Gas Powered Pump<sup>138</sup>. This pump has a maximum flow rate of 216 gallons per minute which is much more than what is required for the system, yet is still affordable, lightweight and compact. The maximum pressure of the pump is rated at 54 psi.

For an exterior water spray system, where the year-round conditions are unpredictable, it is necessary to have a dry pipe system. The pipes are filled with air instead of water and a valve is held in place by the pressure from the air, preventing any water from entering the pipes until the sprinklers are activated. Once the sprinklers are activated all of the air escapes first through the open deluge sprinklers. In an interior dry pipe system, this is not a desirable outcome, as the escaping air would introduce fresh oxygen to the fire environment. In an outdoor application, the air can escape freely without consequence. For our system, a 2" electronic solenoid valve would be required for each side of the house. The specified valve is normally closed, has a pressure range of 0 to 145 psi, and can handle the 69.24 gpm flow requirement<sup>139</sup>. The valve is all brass and can open and close within 1 second of receiving the signal. An image of the valve is present in Figure 38.

---

<sup>136</sup> Ibid.

<sup>137</sup> 3.5 HP Gas Powered Pump

<sup>138</sup> Ibid.

<sup>139</sup> Brass Valves



*Figure 38: 2" Electronic Solenoid Valve<sup>140</sup>*

The system piping and sprinklers can be hung using a variety of methods for this system application but can largely be hung using an adjustable clevis hanger from the eaves of the roof<sup>141</sup>. An example of an acceptable hanger is included in Figure 39:



*Figure 39: An Example Clevis Hanger<sup>142</sup>*

A custom control box would need to be developed in order to open the solenoid valve and turn on the pump once a signal has been received. This could be accomplished through a custom Arduino controller, for instance. If the type of system moved towards mass production, an appropriate control panel could be developed in the future.

---

<sup>140</sup> Ibid.

<sup>141</sup> *Light Duty, Adjustable Clevis Hanger, Carbon Steel*

<sup>142</sup> Ibid.

## 8 Evaluating Trial System Design

To begin with, the selection of trial design 1 over 2 was due to the lower water usage over the design area. The reason for evaluating two designs was to investigate the relationship between water spray coverage, number of nozzles, and system demands. By using one additional nozzle in trial design number 1, the overall area of coverage is smaller than trial design 2, however the design area is still covered. Essentially, water is discharged more efficiently into the desired design area in trial design 1. For this reason, water spray trial design 1 was selected.

Trial design system 1 required 69.24 gpm and 70.54 psi at the riser. This is a significant amount of water. For comparison, the design specification of Mitchell's WEEDS system called for 1 gpm per nozzle. The developed system flows at least 13 gpm per nozzle. However, the design areas for the two systems are different. Per kilogram of smoldering combustible material, the study by Hadden estimated that one to two liters (0.24 to 0.48 gallons) of water is required for suppression<sup>143</sup>. However, this number by Hadden assumes that extinguishment is achieved by total submersion of the material in water. The test placed smoldering peat in insulated trays of 20 x20 cm with a 5 cm depth. The developed water spray is a top down flow of water on top of the brands and subsequent fire. The critical firebrand flux of 17.1 g/m<sup>2</sup>s over the design area of 115 square feet yields 1.96 kg of deposited ponderosa pine per minute. The system design water use requirement of 69.24 gpm is over 144 times greater than Hadden's value. The oversupply of water can be viewed as either a safety factor, taking into account factors such as droplet penetration into the fire. The reason for such a large increase in water usage is due to the fact that the system is activated in order to protect the entire side of the house, not just the affected area where ignition is occurring. Other factors contributing to higher water usage include water transport losses as a result of wind, which were not directly modeled in our scenario due to computational constraints. The WEEDS system study specifically modeled water spray into wind and determined that when discharging water from the eaves of the house, the wind will essentially blow droplets back onto the house, aiding in control overall. Another factor is evaporation. In the dry, hot, and windy environments that often accompany large wildfires, as discussed in Chapter 2, evaporation rates of water are greater than average temperate weather. However, the order of magnitude for water evaporation in this environment over the design area is 10 to 100 liters per hour. This water loss constitutes 2.3% of total discharge over the 30-minute criteria.

Further evaluation of the water discharge against the existing systems and patents introduced in Chapter 2 is difficult due to a lack of specific criteria in those other designs. Instead, the discharge density will be compared to the requirements of NFPA 13 *Standard for Installation of Sprinkler Systems*. Specifically, NFPA 13 Figure 19.3.3.1.1 outlines density/area curves, correlating the hazard group to sprinkler discharge density. With the design discharge density of 0.26 gpm/sqft, as calculated in Section 7.2, the closest occupancy hazard correlation is Extra Hazard Group 1. Extra Hazard Group 1 is defined by Section 3.3.134.1 as an occupancy "where the quantity and combustibility of contents are very high and dust, lint, or other materials are present, introducing the probability of rapidly developing fires with high rates of heat release but with little or no combustible or flammable liquids. Uses and conditions are defined by NFPA 13 Section A.4.3.5 as aircraft hangers, die casting operations, metal extruding, plywood and particleboard manufacturing, saw mills, and similar operations. The control or suppression of an

---

<sup>143</sup> Rory Hadden, *A laboratory study of the effect of moisture content on the spread of smoldering in peat fires*, (2013)

interior fire scenario is different from the firebrand threat due to the constant influx of firebrands in the scenario, actively adding to the fire load, unlike that of many interior building fires that have a more defined fire load and shorter-term ignition source. However, the overall discharge required density of the water spray system is considered reasonable as it corresponds to the high quantity of dust and particles that may be present in Extra Hazard Group 1 occupancy hazards. To be clear, the control and suppression methodology of an interior sprinkler system is much more refined and better studied than an exterior system, particularly for a wildfire application. Above all else, further evaluation of nozzle discharge characteristics is needed to fully evaluate water spray system design for this application. Further discussion will occur in Chapter 9 of this report.

Maintenance for the system should be conducted in order to maintain reliability. This study did not evaluate maintenance techniques. System maintenance could be considered a topic for future work.

Once a system has been created, the effect of the system can be quantified through a failure analysis. This type of logic defines each type of failure into subsets for later examination. An example failure analysis tree can be observed in Figure 40. Each time a system is tested and fails in one way or another, the failure can be categorized, and a redesign can be targeted to fix the problem.

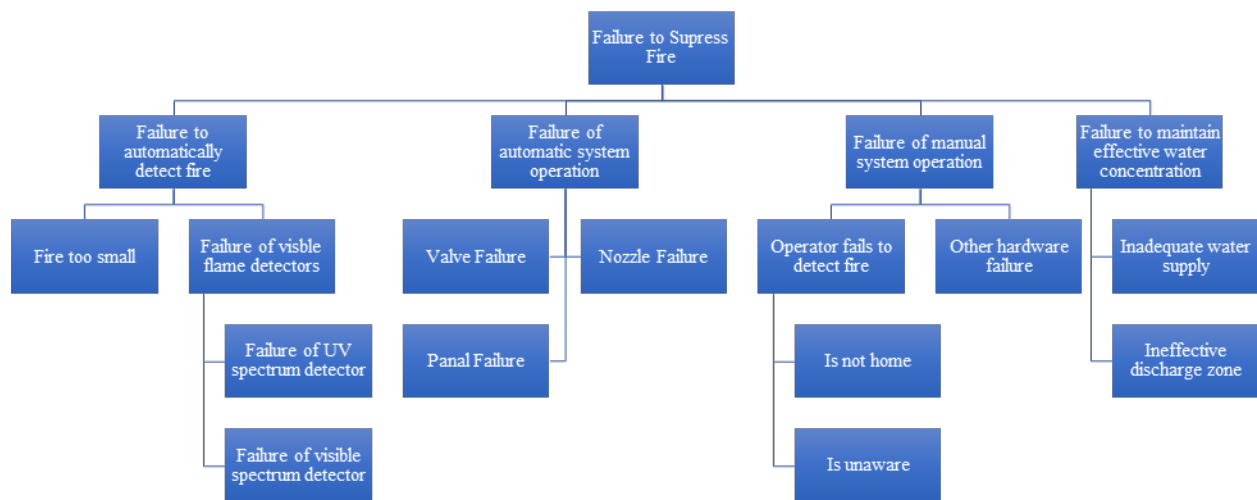


Figure 40: System Fault Tree

By utilizing this fault tree, future system design iterations can be targeted to address key failures over time.

## 9 Recommendations for Future Work

There are a number of key areas for future work needed in order to better control the loss of residential homes due to firebrands. This project demonstrates conceptually that a system can be designed and installed to address the threat of firebrand induced ignition on a house for a specified set of conditions. However, the system lacks refinement due to a lack of information on firebrand accumulation intensity and duration. In particular, zero studies have been conducted examining the duration of concentrated firebrand fluxes. Most of the in-field firebrand research was based after large wildfires had already passed through a community or for low to medium intensity prescribed burns. Knowing not only the long-range total vulnerability time (the time it takes for the flame front to generate significant firebrands in addition to an appropriate wind profile), but rather the most intense firebrand flux would be incredibly beneficial to overall system design. Currently, the critical firebrand flux of  $17.1 \text{ g/m}^2\text{s}$ <sup>144</sup> over the design time of 30 minutes based on the total mass of firebrands entering the design area of 115 square feet yields 59 kg of deposited ponderosa pine, significantly more than any NIST Dragon test by an order of magnitude. The critical firebrand flux is an average from starting input mass into the Dragon over time, with visual observations being the only indicator of flaming combustion. Therefore, the time and intensity of firebrand flux is a critical factor in determining ignition time and deriving a basic water spray discharge density and duration.

Another key area of future work includes the physical and thermal insulation that occurs as smoldering piles of firebrands accumulate. Varying configurations of accumulation will yield different penetration effectiveness results from the water spray. Some smoldering fires need to be drowned in order to be quenched, as this type of combustion burns over a significant amount of time as compared to flaming combustion<sup>145</sup>. Laboratory and field tests of the exterior water spray systems should be developed in order to measure system effectiveness adequacy.

A further area of improvement involves the implementation of FDS. The program is excellent at determining smoke production and its subsequent components in a volume. However, it falls short of being able to model complex particle interactions. An example of this is the effect of friction on surfaces. No input exists for the coarseness of a surface, nor a friction factor. When a droplet strikes a horizontal surface, it is distributed randomly. When it contacts a vertical surface, it falls vertically. As an approximation, this may be enough for some applications, yet in understanding the accumulation of water over the design area after interacting with smoldering particles, the program does not provide enough detail. Furthermore, as observed in multiple accumulation tests, 3D accumulation is not supported. Each particle, regardless of input size, does not collide nor interact with one another with the exception of other input variables such as external heat flux. A different software modeling solution or field test will be required to understand firebrand accumulation and then the effect of water spray on top of that.

One additional area of concern in the model was the accuracy of the representation of the house in the model. The sloped roof is represented as blocks which causes the firebrands to

---

<sup>144</sup> Suzuki, *Experimental Investigation of Firebrand Accumulation Zones in Front of Obstacles*, (2017)

<sup>145</sup> Rein, *SFPE Handbook*, Chapter 19.

accumulate differently than they would in reality on a sloped surface. Additionally, the window and door treatments, where particle accumulation occurs, are not represented well. Conversely, FDS cannot merge two smaller particles to equal one larger particle. This simplification would have proven useful for modeling firebrand accumulation patterns based on the defined distribution and transportation, however the simulation did not have that capability.

Water spray characteristics, including droplet size, penetration, and motion, need to be evaluated for the firebrand application. Factors such as wind velocity, humidity, and levels of char all play a role in how effective a given droplet of water will remove heat from a brand. Efforts have been made to quantify the overall heat of a brand, but not the direct or indirect impingement of water, particularly with fire weather conditions. The role of wind is not well understood in this application and could be evaluated further in order to understand if there is a negative or positive relationship in water delivery for this application.

Another area of future work includes the evaluation of the detection system, which still has a risk of being activated accidentally through another source of UV energy. Work into preventing accidental activation should include evaluating the potential for redundancy or the use of another sensor in order to detect the threat.

Maintenance is another critical aspect of system effectiveness. No maintenance schedule exists for the current system. An investigation would include a failure analysis of system components over time in order to provide preventative maintenance on future systems. The objective would be to maximize the potential for system activation and discharge while minimizing the cost to the homeowner.

Finally, the other products currently on the market, at least publicly, do not quantify the discharge criteria based on the threat of either wildfire flame fronts nor firebrands. The process of performance-based design implemented in the application of the designed system in Chapter 7 first considers the design fire before the system. Most existing patents essentially place ‘the cart before the horse’ in devising a solution to a problem which isn’t well defined. It is hoped that by continuing research into the threat of firebrands, more effective iterations of firebrand suppression systems can be implemented down the road. Even the fire load of the outside of a residential home is not well understood.



## 10 Conclusion

Wildfires are destroying millions of acres of forest yearly, putting residential homes and commercial buildings at risk as individuals continue to settle in the Wildland Urban Interface (WUI). This project utilized a Performance-Based Design approach to develop and evaluate an exterior water spray system for improving the survivability of a residential structure from a firebrand exposure during a wildfire event. A fire scenario was developed to quantify the wildfire threat and study the impact of firebrands on residential structures. Firebrand transport and accumulation were mathematically modeled using Fire Dynamic Simulator (FDS). A water spray system was developed to meet specific goals for the scenario defined. The system was designed so that the average homeowner could purchase commercially available components and have the system installed. The proposed system includes ultraviolet radiant energy detectors to detect flaming combustion in an outdoor environment. Upon activation, the water spray system discharges water down the sides of the exterior wall and onto the adjacent deck. The design includes an external water source consisting of a tank and pump to supply the system with the necessary water flow.

Recommendations for future work into the complicated problem of firebrand control and suppression in the WUI were made including observing and quantifying maximum firebrand rates of accumulation on a surface. Additionally, to collect accurate data, embers must be studied in-situ and in real time. This data will allow the system proposed by this project to be refined and provide better protection for the structure in the future, increasing system performance as a result. Other recommendations for future work involve improvements on detection, and understanding of water spray in a wind-driven environment, and refinements to FDS inputs.

In summation, by addressing the threat of firebrand ignition in the corners of residential structures, a conceptual firefighting system was developed using UV detection in order to apply water spray to control the fire. The system discharge and water usage were compared against existing designs for other threats and scenarios, such as the WEEDS system. In working to limit the ignition of structures behind the fire line during wildfires, it is possible to reduce the severity of the wildfire events overall. If fire spread can be limited within communities present in the WUI, then overall property loss and ultimately loss of life can be reduced. Catastrophic results, such as the Camp Fire, can be reduced through individual systems on properties, robust community design, and organizational commitment to limiting residential loss.

## Bibliography

- 2100 Gallon Norwesco Plastic Potable Water Storage Tank.* (n.d.). Retrieved from Plastic-Mart: <https://www.plastic-mart.com/product/12137/2100-gallon-plastic-water-storage-tank>
- 3.5 HP Gas Powered Pump.* (n.d.). Retrieved from Plastic-Mart: <https://www.plastic-mart.com/product/3765/briggs-2-inch-3-hp-pump-ba200p-3>
- AbdRabbo, M. F., Ayoub, A. M., Ibrahim, M. A., & Sharaf eldin, A. M. (2016). Study the Properties of Water Mist Droplet by Using FDS. *Journal of Civil & ENvironmental Engineering*.
- Brass Valves.* (n.d.). Retrieved from Electronic Solenoid Valves: <https://www.electricsolenoidvalves.com/2-110v-ac-electric-brass-solenoid-valve/>
- California Fire Weather.* (n.d.). Retrieved from National Weather Service: <https://www.wrh.noaa.gov/fire2/cafw/index.php>
- California Statewide Fire Map.* (2018). Retrieved from CalFire: <http://www.fire.ca.gov/general/firemaps>
- Center, N. I. (2016). *Wildland FIre Summary and Statistics Annual Report*. National Interagency Fire Center.
- Coddinton, K. (2017, November 27). *Which Roofing Materials are the Most Fire Resistant?* Retrieved from The Roofing Company Las Vegas: <https://www.theroofingcompanylasvegas.com/blog/fire-resistant-roofing-materials>
- Cohen, J. (2004). Relating Flame Radiation to Home Ignition Using Modeling and Experimental Crown Fires. *Candadian Journal of FOrrest Resources*, 1616-1626.
- CSI Specifications.* (2018). Retrieved from American FIBer Cement Corp.: <https://www.arcat.com/company/30401/spec>
- Daniels, J. (2018, August 10). *California spends more than half of annual fire budget in 40 days, as big blazes continue to burn.* Retrieved from CNBC: <https://www.cnbc.com/2018/08/10/california-spends-more-than-half-of-annual-fire-budget-in-40-days.html>
- Density of Some Common Building Materials.* (n.d.). Retrieved from rfcafe: <http://www.rfcafe.com/references/general/density-building-materials.htm>
- Drysdale, D. (2011). *An Introduction to Fire Dynamics*. Wiley.
- Emissivity Coefficients Materials.* (n.d.). Retrieved from The Engineering ToolBox: [https://www.engineeringtoolbox.com/emissivity-coefficients-d\\_447.html](https://www.engineeringtoolbox.com/emissivity-coefficients-d_447.html)
- Emissivity Table.* (n.d.). Retrieved from ThermoWorks: [https://www.thermoworks.com/emissivity\\_table](https://www.thermoworks.com/emissivity_table)

- Emissivity Values for Common Materials.* (n.d.). Retrieved from Infrared Thermography:  
<http://www.infrared-thermography.com/material-1.htm>
- Facts + Statistics: Wildfires.* (2018). Retrieved from Insurance Information Institute:  
<https://www.iii.org/fact-statistic/facts-statistics-wildfires#Wildland%20fires>
- Federal Firefighting Costs (Suppression Only).* (2017). Retrieved from NIFC:  
[https://www.nifc.gov/fireInfo/fireInfo\\_documents/SuppCosts.pdf](https://www.nifc.gov/fireInfo/fireInfo_documents/SuppCosts.pdf)
- Finney, M. A. (2015). Role of Buoyant Flame Dynamics in Wildfire Spread. *Proceedings of the National Academy of Sciences of the United States of America.*
- Fire Dynamics Simulator.* (2018, July 10). Retrieved from Wikipedia:  
[https://en.wikipedia.org/wiki/Fire\\_Dynamics\\_Simulator](https://en.wikipedia.org/wiki/Fire_Dynamics_Simulator)
- Fire Ignition, behavior & effects.* (2019). Retrieved from Idaho Firewise:  
<http://idahofirewise.org/fire-ecology-and-management/wildfire-ignition-behavior-and-effects/>
- Fixed Water Spray Systems for Fire Protection.* (2010, May). Retrieved from FM Global:  
<https://www.fmglobal.com/research-and-resources/fm-global-data-sheets>
- Formisano, B. (2018, August 21). *The Most Popular Siding Choices for the Home.* Retrieved from The Spruce: <https://www.thespruce.com/types-of-siding-for-the-home-1824718>
- Frassetto, R. (2012, February 01). *Understanding Building Construction Types.* Retrieved from Fire Rescue: <https://www.firerescuemagazine.com/articles/print/volume-7/issue-2/truck-co-operations/understanding-building-construction-types.html>
- Gelaude, J. L. (1984). *United States Patent No. 4428434.*
- Glass Physical Properties.* (n.d.). Retrieved from Viridian Glass:  
<https://www.viridianglass.com/-/media/viridian-glass/files/downloads/brochures/glass-physical-properties.pdf>
- Gollner, M. J., Hakes, R., Canton, S., & Kohler, K. (2015). Pathways for Building Fire Spread at the Wildland Urban Interface. *Fire Protection Research Foundation.*
- Hadden, R. (2013). A laboratory study of the effect of moisture content on the spread of smouldering in peat fires. *ResearchGate*, 35-38.
- Hadden, R., & Rein, G. (2011). Buring and Water Suppression of Smoldering Coal Fires in Small-Scale Laboratory Experiments. *ResearchGate.*
- Hakes, R. (2017). Thermal Characterization of Firebrand Piles. *Digital Repository at the University of Maryland.*
- Hall-Rivera, J. (2018). *Wildland Fire Management.* Washington, DC: Forest Service Manual.

- Hays, B. (2018, July 31). *10 Strategies Firefighters Use to Fight Wildfires*. Retrieved from Mental Floss: <http://mentalfloss.com/article/57094/10-strategies-fighting-wildfires>
- Hope, B. (2018, October 2). *Climate Change is Forcing the Industry to Recalculate*. Retrieved from The Wall Street Journal: <https://www.wsj.com/graphics/climate-change-forcing-insurance-industry-recalculate/?ns=prod/accounts-wsj>
- Hurley, M. J. (2016). *SFPE Handbook of Fire Protection Engineering*. Springer.
- Johnson, J. F., Downing, T., & Nelson, K. C. (2008). External Sprinkler Systems and Defensible Space: Lessons Learned from the Ham Lake Fire and the Gunflint Trail. *University of Minnesota*.
- Koo, E., Pagni, P., Weise, D., & Woycheese, J. (2010). Firebrands and spotting ignition in large scale fires. *International Journal of Wildland Fire*.
- Largest Loss Wildland Fires*. (2018, December). Retrieved from NFPA: <https://www.nfpa.org/News-and-Research/Data-research-and-tools/Wildland-Urban-Interface/Wildland-Urban-Interface/Largest-loss-wildland-fires>
- Learn More About Wildfires*. (2019). Retrieved from National Geographic: T.J. Ohlemiller, Smoldering Combustion, (Gaithersburg, MD, 1986)
- Light Duty, Adjustable Clevis Hanger, Carbon Steel*. (n.d.). Retrieved from Grainger: <https://www.grainger.com/product/ANVIL-Light-Duty-4HXV3>
- Mahmud, I. (2016). Experimental and numerical study of high-pressure water-mist nozzle sprays. *Fire Safety Journal*, 109-117.
- Manzello, S. L. (2017). Experimental Investigation of Wood Decking Assemblies Exposed to Firebrand Showers. *Science Direct Fire Safety Journal*.
- Manzello, S. L., & Sayaka, S. (n.d.). Experimentally Simulating Wind Driven Firebrand Showers in Wildland Urban Interface Fires.
- Manzello, S. L., & Suzuki, S. S. (2013). Experimentally Simulating Continuous Wind Driven Firebrand Showers in Wildland-Urban Interface Fires. *NIST*.
- Manzello, S. L., Maranghides, A., & Mell, W. E. (2007). Firebrand Generation from Burning Vegetation. *International Journal of Wildland Fire*, 458-462.
- Manzello, S. L., Suzuki, S., & Hayashi, Y. (2012). Enabling the study of structure vulnerabilities to ignition from wind driven firebrand showers. *Fire Safety Journal*.
- Maranghides, A., McNamara, D., Mell, W., Trook, J., & Toman, B. (2013). A Case Study of a Community Affected by the Witch and Guejito Fires. *Nation Institute of Standards and Technology*.
- Marin County Community Wildfire Protection Plan 2016*. (2016). Retrieved from Fire Safe Marin: <http://www.firesafemarin.org/cwpp>

- McGrattan, K., Hostikka, S., McDermott, R., Floyd, J., & Vanella, M. (2018, June 26). *Fire Dynamics Simulator User's Guide*. Retrieved from National Institute of Standards and Technology: <https://pages.nist.gov/fds-smv/manuals.html>
- Mega Fires: The Case for Mitigation*. (2007, October 21). Retrieved from Institute for Business & Home Safety: [https://disastersafety.org/wp-content/uploads/wildfire\\_megafires\\_full.pdf](https://disastersafety.org/wp-content/uploads/wildfire_megafires_full.pdf)
- (2017). *MEGA FIRES: The Case for Mitigation*. Institute for Business & Home Safety.
- Member Agencies Contacts*. (n.d.). Retrieved from Prevent Wildfires CA: <http://www.preventwildfireca.org/Member-Agencies>
- Meredith, K. (2013). A comprehensive model for simulating the interaction of water with solid surfaces in fire suppression environments. *Elsevier*, 2719-2726.
- Mitchell, J. (2006, September). Wind-enabled Ember Dousing. *Fire Safety Journal*, 444-458. Retrieved from <https://www.sciencedirect.com/science/article/pii/S0379711206000567?via%3Dihub>
- Model E Spray Nozzle*. (n.d.). Retrieved from Viking: <http://www.vikingcorp.com/model-e-spray-nozzles-0>
- Moussa. (1977). Mechanism of smoldering of cellulosic materials. *Symposium (International) on Combustion 16*, 1447-1457.
- October in Sacramento*. (2018). Retrieved from Weather and Climate: <https://weather-and-climate.com/sacramento-california-us-October-averages-fahrenheit>
- Ohlemiller, T. (1986). Smoldering COmbustion. *U.S. Department of Commerce*.
- Perry, M. J. (2016, June 5). *New US homes today are 1,000 square feet larger than in 1973 and living space per person has nearly doubled*. Retrieved from AEI: <http://www.aei.org/publication/new-us-homes-today-are-1000-square-feet-larger-than-in-1973-and-living-space-per-person-has-nearly-doubled/>
- Pine/Redwood (Pinus silvestris)*. (n.d.). Retrieved from Tratalija: [http://www.tratalija.se/ckfinder/userfiles/files/Pine\\_Redwood\\_Pinus%20silvestris.pdf](http://www.tratalija.se/ckfinder/userfiles/files/Pine_Redwood_Pinus%20silvestris.pdf)
- Ponderosa Pine*. (2015, February 24). Retrieved from National Park Service: <https://www.nps.gov/brca/learn/nature/ponderosapine.htm>
- Property Loss Prevention Data Sheet: Wildland Fire*. (2017, January). Retrieved from FM Global .
- Quarles, S. L. (2012, April 25). *Vulnerabilities of Buildings to Wildfire Exposures*. Retrieved from Extension: [https://articles.extension.org/pages/63495/vulnerabilities-of-buildings-to-wildfire-exposures#.U5HVJ\\_mwLYg](https://articles.extension.org/pages/63495/vulnerabilities-of-buildings-to-wildfire-exposures#.U5HVJ_mwLYg)

- Quarles, S. L., & Sindeclar, M. (2011). Wildfire Ignition Resistant Home Design Program: Full-scale Testing and Demonstration Final Report. *UNT Library*.
- Radeloff, V. C. (2005). The Wildland Urban Interface in the United States. *Ecological Applications*, 799-805.
- Radio connection system Wireless Wire*. (n.d.). Retrieved from Schalk: <https://www.schalk.de/radio-connection-system.html>.
- Schmidt, G. (n.d.). *Outdoor Deck Size Tips*. Retrieved from Landscaping Network: <https://www.landscapingnetwork.com/decks/size.html>
- Security Sensors/TX-124R*. (2010). Retrieved from Takex: <https://takex.com/tx-124r-pr-2240.php?c=1>
- Sheds, Free Standing Garages & Outbuildings* . (2018, May 29). Retrieved from City of Mandurah.
- Sikanen, T. (2006, March 1). *An Innovative Approach of Integrated Wildland Fire Management Regulating the Wildfire Problem by the WIsE Use of Fire*. Retrieved from Fire Paradox: <http://www.eufirelab.org/toolbox2/library/upload/2681.pdf>
- Siniavskaia, N. (July, 11 2016). *Lots in 2015 are Smallest on Record*. Retrieved from Eye on Housing: <http://eyehousing.org/2016/07/lots-in-2015-are-smallest-on-record/>
- Smagac, D. (1992). *United States Patent No. 5165482*.
- Smith, D. (2018). *National Multi-Agency Coordinating Group Operations Plan*. Retrieved from National Association of State Foresters Fire Director, NIFC: <https://www.nifc.gov/nicc/administrative/nmac/NMACOpsPlan.pdf>
- Specific Heat of Common Substances*. (n.d.). Retrieved from The Engineering ToolBox: [https://www.engineeringtoolbox.com/specific-heat-capacity-d\\_391.html](https://www.engineeringtoolbox.com/specific-heat-capacity-d_391.html)
- SPRAYSAFE Autonomous Fire Suppression (AFS) Technology*. (2018). Retrieved from Johnson Controls: <http://tycofpp.com/spraysafe>
- Standard Firebrand Generator*. (2014, June 3). Retrieved from National Institute of Standards and Technology: <https://www.nist.gov/laboratories/tools-instruments/standard-firebrand-generator>
- Suzuki, S., & Manzello, S. L. (2017). Experimental Investigation of Firebrand Accumulation Zones in Front of Obstacles. *Science Direct*.
- Technical Data Sheet Redwood*. (n.d.). Retrieved from California Redwood Association: <http://www.calredwood.org/pdf/Decking+Fire+Standards.pdf>
- Thermal Conductivity of common Materials and Gases*. (n.d.). Retrieved from The Engineering ToolBox: [https://www.engineeringtoolbox.com/thermal-conductivity-d\\_429.html](https://www.engineeringtoolbox.com/thermal-conductivity-d_429.html)

- Thermodynamics: Heat and Enthalpy*. (n.d.). Retrieved from ChemPages:  
<https://www.chem.wisc.edu/deptfiles/genchem/netorial/modules/thermodynamics/enthalpy/enthalpy3.htm>
- Thomas, D., Butry, D., Gilbert, S., Webb, D., & Fung, J. (2017). *The Costs and Losses of Wildfires*. NIST.
- Toumisaari, M. (1998). Extinguishing smoldering fires in silos. *VTT Publications*.
- Understanding Water Supply for Home Fire Sprinkler Systems*. (2012). Retrieved from Home Fire Sprinkler: <https://homefiresprinkler.org/wp-content/uploads/2016/05/water-purveyors-brochure.pdf>.
- Walsh, P. (n.d.). *Wood Decking Materials*. Retrieved from The Wall Street Journal:  
<https://www.hgtv.com/remodel/outdoors/wood-decking-materials>
- Weight of Tempered Glass*. (n.d.). Retrieved from Glass on Web:  
<https://www.glassonweb.com/forums/weight-tempered-glass>
- Wildland Fire Management - Agencies and Their Roles*. (n.d.). Retrieved from National Interagency Fire Center: [https://www.nifc.gov/prevEdu/comm\\_guide/ch3.html](https://www.nifc.gov/prevEdu/comm_guide/ch3.html)
- Wood, Panel and Structural Timber Properties - Mechanical Properties*. (n.d.). Retrieved from The Engineering Toolbox: [https://www.engineeringtoolbox.com/timber-mechanical-properties-d\\_1789.html](https://www.engineeringtoolbox.com/timber-mechanical-properties-d_1789.html)
- Yamodo, I. (2011). *United States Patent No. 20110226479*.
- Your California Fire Information Center*. (2018). Retrieved from University of California Cooperative Extension: <http://ucanr.edu/sites/Wildfire/>

## Appendix A: Structural Losses by Wildfire as Reported by the NIFC

Table 3: 2016 Structural Losses by Wildfire<sup>146</sup>

Structure Type	Number of Losses
Residential	3,192
Minor Structure	1,025
Commercial	78
Mixed Commercial/ Residential	17

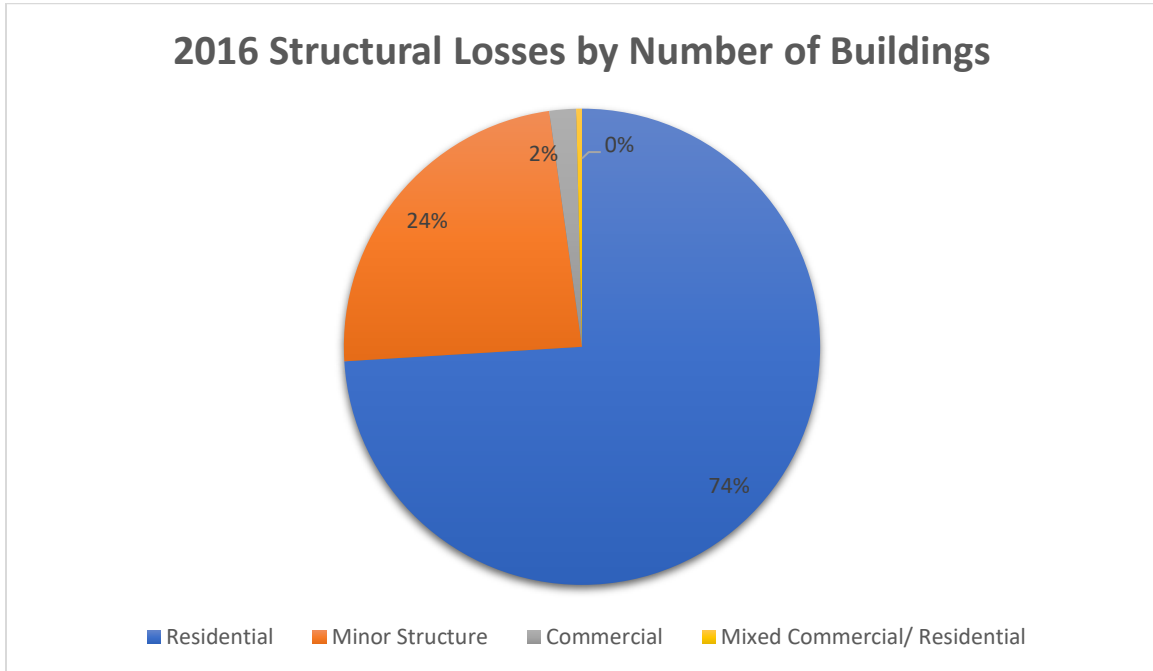


Figure 41: 2016 Structural Losses by Number of Buildings<sup>147</sup>

Table 4: 2017 Structural Losses by Wildfire<sup>148</sup>

Structure Type	Number of Losses
Residential	8065
Minor Structure	4002
Commercial	229
Mixed Commercial/ Residential	10

<sup>146</sup> Center, *Wildland Fire Summary and Statistics Annual Report*, (2016)

<sup>147</sup> Ibid.

<sup>148</sup> Ibid.



### 2017 Structural Losses by Number of Buildings

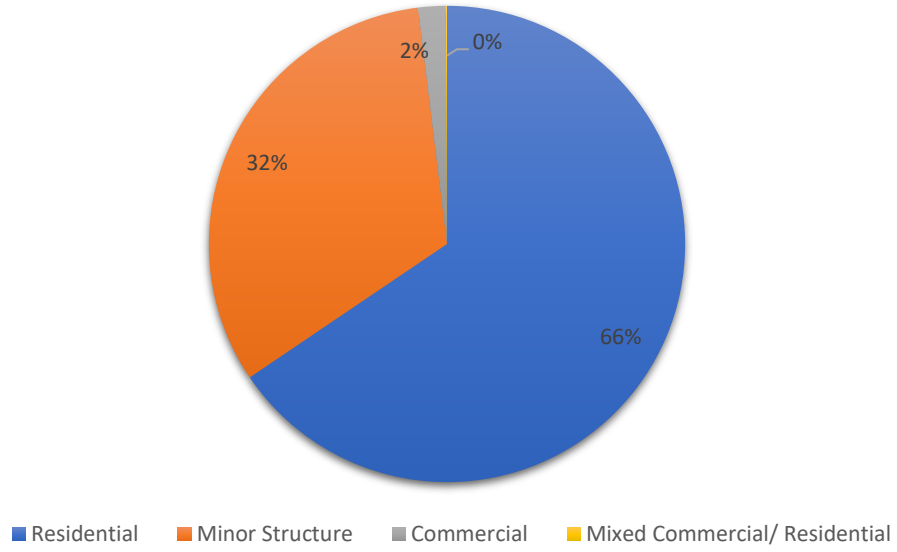


Figure 42: 2017 Structural Losses by Number of Buildings<sup>149</sup>

---

<sup>149</sup> Ibid.

## Appendix B: FDS Source Code

dragon\_5a.fds

Generated by PyroSim - Version 2018.2.0730

Oct 7, 2018 4:20:18 PM

-----User Section (not generated by PyroSim)-----

&PROP ID='rod image', SMOKEVIEW\_ID='tube', SMOKEVIEW\_PARAMETERS='D=0.008'/

-----PyroSim-generated Section-----

&HEAD CHID='dragon\_5a', TITLE='Manzello et al., FSJ (2008), Fig 5a'/

&TIME T\_END=60.0/

&DUMP RENDER\_FILE='dragon\_5a.ge1', COLUMN\_DUMP\_LIMIT=.TRUE., DT\_RESTART=300.0,  
DT\_SL3D=0.25/

&MESH ID='Mesh01-a', IJK=18,20,30, XB=-1.0,1.1,-0.5,1.5,0.0,3.0/

&MESH ID='Mesh01-b', IJK=12,20,30, XB=1.1,2.5,-0.5,1.5,0.0,3.0/

&PART ID='rods',

    SURF\_ID='brand',

    DRAG\_LAW='CYLINDER',

    QUANTITIES='PARTICLE DIAMETER','PARTICLE MASS','PARTICLE TEMPERATURE',

    PROP\_ID='rod image'/

&REAC ID='Reaction1',

    FUEL='REAC\_FUEL',

    FORMULA='C6H10O5',

SOOT\_YIELD=0.015/

&MATL ID='wood',

SPECIFIC\_HEAT=1.0,

CONDUCTIVITY=0.1,

DENSITY=440.0,

HEAT\_OF\_COMBUSTION=1.5E4,

N\_REACTIONS=1,

HEAT\_OF\_REACTION=1000.0,

MATL\_ID(1,1)='char',

NU\_MATL(1,1)=0.08,

SPEC\_ID(1,1)='REAC\_FUEL',

NU\_SPEC(1,1)=0.92,

REFERENCE\_TEMPERATURE=300.0/

&MATL ID='char',

SPECIFIC\_HEAT=1.0,

CONDUCTIVITY=0.1,

DENSITY=71.0/

&MATL ID='STEEL',

SPECIFIC\_HEAT=0.465,

CONDUCTIVITY=54.0,

DENSITY=7850.0/

&SURF ID='brand',

MATL\_ID(1,1)='wood',

MATL\_MASS\_FRACTION(1,1)=1.0,

THICKNESS(1)=4.0E-3,

GEOMETRY='CYLINDRICAL',

LENGTH=0.0135,

```
INNER_RADIUS=0.0,
EXTERNAL_FLUX=50.0/
&SURF ID='STEEL SHEET',
  COLOR='BLACK',
  MATL_ID(1,1)='STEEL',
  MATL_MASS_FRACTION(1,1)=1.0,
  THICKNESS(1)=2.0E-3,
  FREE_SLIP=.TRUE./
&SURF ID='BLOWER',
  COLOR='BLUE',
  VEL=-3.0/

&INIT ID='rods', PART_ID='rods', N_PARTICLES=5, DT_INSERT=0.5, XB=-0.3,-0.1,-0.1,0.1,1.1,1.6/
&INIT ID='rods2', PART_ID='rods', N_PARTICLES=5, DT_INSERT=0.5, XB=-0.3,-0.1,0.9,1.1,1.1,1.6/

&OBST ID='Obstruction #1', XB=-0.3,-0.1,0.9,0.9,0.0,2.25, SURF_ID='STEEL SHEET'/
&OBST ID='Obstruction #2', XB=-0.3,-0.1,1.1,1.1,0.0,2.25, SURF_ID='STEEL SHEET'/
&OBST ID='Obstruction #3', XB=-0.3,-0.3,0.9,1.1,0.0,2.25, SURF_ID='STEEL SHEET'/
&OBST ID='Obstruction #4', XB=-0.1,-0.1,0.9,1.1,0.0,2.1, SURF_ID='STEEL SHEET'/
&OBST ID='Obstruction #5', XB=-0.1,0.0,0.9,0.9,2.1,2.25, SURF_ID='STEEL SHEET'/
&OBST ID='Obstruction #6', XB=-0.1,0.0,1.1,1.1,2.1,2.25, SURF_ID='STEEL SHEET'/
&OBST ID='Obstruction #7', XB=-0.3,0.0,0.9,1.1,2.25,2.25, SURF_ID='STEEL SHEET'/
&OBST ID='Obstruction #8', XB=-0.1,0.0,0.9,1.1,2.1,2.1, SURF_ID='STEEL SHEET'/
&OBST ID='Obstruction #9', XB=-0.3,-0.1,0.9,1.1,0.9,1.0, SURF_IDS='BLOWER','STEEL SHEET','STEEL SHEET'/

&OBST ID='Obstruction #1', XB=-0.3,-0.1,-0.1,-0.1,0.0,2.25, SURF_ID='STEEL SHEET'/
&OBST ID='Obstruction #2', XB=-0.3,-0.1,0.1,0.1,0.0,2.25, SURF_ID='STEEL SHEET'/
&OBST ID='Obstruction #3', XB=-0.3,-0.3,-0.1,0.1,0.0,2.25, SURF_ID='STEEL SHEET'/
&OBST ID='Obstruction #4', XB=-0.1,-0.1,-0.1,0.1,0.0,2.1, SURF_ID='STEEL SHEET'/
```

&OBST ID='Obstruction #5', XB=-0.1,0.0,-0.1,-0.1,2.1,2.25, SURF\_ID='STEEL SHEET'/  
&OBST ID='Obstruction #6', XB=-0.1,0.0,0.1,0.1,2.1,2.25, SURF\_ID='STEEL SHEET'/  
&OBST ID='Obstruction #7', XB=-0.3,0.0,-0.1,0.1,2.25,2.25, SURF\_ID='STEEL SHEET'/  
&OBST ID='Obstruction #8', XB=-0.1,0.0,-0.1,0.1,2.1,2.1, SURF\_ID='STEEL SHEET'/  
&OBST ID='Obstruction #9', XB=-0.3,-0.1,-0.1,0.1,0.9,1.0, SURF\_IDS='BLOWER','STEEL SHEET','STEEL SHEET'/

&VENT ID='Mesh Vent: Mesh01 [XMIN]', SURF\_ID='OPEN', XB=-1.0,-1.0,-0.5,1.5,0.0,3.0/  
&VENT ID='Mesh Vent: Mesh01 [XMAX]', SURF\_ID='OPEN', XB=2.5,2.5,-0.5,1.5,0.0,3.0, IOR=-1/  
&VENT ID='Mesh Vent: Mesh01 [YMIN]', SURF\_ID='OPEN', XB=-1.0,2.5,-0.5,-0.5,0.0,3.0/  
&VENT ID='Mesh Vent: Mesh01 [YMAX]', SURF\_ID='OPEN', XB=-1.0,2.5,1.5,1.5,0.0,3.0/  
&VENT ID='Mesh Vent: Mesh01 [ZMAX]', SURF\_ID='OPEN', XB=-1.0,2.5,-0.5,1.5,3.0,3.0/

&SLCF QUANTITY='TEMPERATURE', XB=-1.0,2.5,-0.5,1.5,0.0,2.75, FYI='Temperature'/  
&SLCF QUANTITY='HRRPUV', XB=-1.0,2.5,-0.5,1.5,0.0,2.75, FYI='HRR'/  
&SLCF QUANTITY='PARTICLE FLUX X', PART\_ID='rods', XB=-1.0,2.5,1.5,1.5,0.0,2.75, FYI='Velocity'/

&TAIL /

firebrand\_dragon.fds

Generated by PyroSim - Version 2018.2.0730

Oct 6, 2018 4:01:10 PM

-----User Section (not generated by PyroSim)-----

&PROP ID='needle image', SMOKEVIEW\_ID='TUBE', SMOKEVIEW\_PARAMETERS='D=0.0025'/

-----PyroSim-generated Section-----

&HEAD CHID='firebrand\_dragon', TITLE='simple test of firebrand\_dragon'/

&TIME T\_END=63.0/

&DUMP RENDER\_FILE='firebrand\_dragon.ge1', DT\_DEVC\_LINE=30.0/

&MESH ID='Mesh01', IJK=40,33,24, XB=0.0,10.0,-4.0,4.25,0.0,6.0/

&SPEC ID='WATER VAPOR'/

&PART ID='firebrands',

    SURF\_ID='wet vegetation',

    QUANTITIES='PARTICLE DIAMETER',

    PROP\_ID='needle mage',

    TURBULENT\_DISPERSION=.TRUE./

&MATL ID='PINE',

    SPECIFIC\_HEAT=1.0,

    CONDUCTIVITY=0.1,

    DENSITY=500.0,

```
N_REACTIONS=1,
HEAT_OF_REACTION=1000.0,
MATL_ID(1,1)='CHAR',
NU_MATL(1,1)=0.2,
REFERENCE_TEMPERATURE=300.0/
&MATL ID='CHAR',
SPECIFIC_HEAT=1.6,
CONDUCTIVITY=1.0,
DENSITY=200.0/
&MATL ID='MOISTURE',
SPECIFIC_HEAT=4.184,
CONDUCTIVITY=0.1,
DENSITY=1000.0,
N_REACTIONS=1,
HEAT_OF_REACTION=2500.0,
SPEC_ID(1,1)='WATER VAPOR',
NU_SPEC(1,1)=1.0,
REFERENCE_TEMPERATURE=100.0/

&SURF ID='wind',
RGB=0,0,0,
TRANSPARENCY=0.0,
VEL=-1.0/
&SURF ID='ground',
FREE_SLIP=.TRUE./
&SURF ID='OPENING',
VEL=-5.0,
PART_ID='firebrands',
PARTICLE_MASS_FLUX=0.1/
```



&SURF ID='wet vegetation',

MATL\_ID(1,1:2)='PINE','MOISTURE',

MATL\_MASS\_FRACTION(1,1:2)=0.8,0.2,

THICKNESS(1)=2.5E-3,

GEOMETRY='CYLINDRICAL',

LENGTH=0.01,

INNER\_RADIUS=0.0/

&OBST ID='Obstruction #1', XB=4.0,4.25,0.0,0.25,1.25,1.5,  
SURF\_ID6='INERT','OPENING','INERT','INERT','INERT','INERT'/

&VENT ID='Mesh Vent: Mesh01 [XMIN]', SURF\_ID='wind', XB=0.0,0.0,-4.0,4.25,0.0,6.0/

&VENT ID='Mesh Vent: Mesh01 [XMAX]', SURF\_ID='OPEN', XB=10.0,10.0,-4.0,4.25,0.0,6.0/

&VENT ID='Mesh Vent: Mesh01 [YMIN]', SURF\_ID='MIRROR', XB=0.0,10.0,-4.0,-4.0,0.0,6.0/

&VENT ID='Mesh Vent: Mesh01 [YMAX]', SURF\_ID='MIRROR', XB=0.0,10.0,4.25,4.25,0.0,6.0/

&VENT ID='Mesh Vent: Mesh01 [ZMAX]', SURF\_ID='OPEN', XB=0.0,10.0,-4.0,4.25,6.0,6.0/

&VENT ID='Mesh Vent: Mesh01 [ZMIN]', SURF\_ID='ground', XB=0.0,10.0,-4.0,4.25,0.0,0.0/

&SLCF QUANTITY='VELOCITY', VECTOR=.TRUE., PBX=0.125/

&SLCF QUANTITY='VELOCITY', VECTOR=.TRUE., PBZ=5.0/

&DEVC ID='mass\_SURFACE INTEGRAL', QUANTITY='AMPUA', PART\_ID='firebrands',  
STATISTICS='SURFACE INTEGRAL', XB=6.0,7.0,-1.0,1.0,0.0,0.0/

&TAIL /

house\_rightscale.fds

Generated by PyroSim - Version 2018.2.0730

Oct 24, 2018 2:54:15 PM

-----User Section (not generated by PyroSim)-----

&PROP ID='rod image', SMOKEVIEW\_ID='tube', SMOKEVIEW\_PARAMETERS='D=0.008'/

-----PyroSim-generated Section-----

&HEAD CHID='house\_rightscale', TITLE='Manzello et al., FSJ (2008), Fig 5a'/

&TIME T\_END=100.0/

&DUMP RENDER\_FILE='house\_rightscale.ge1', COLUMN\_DUMP\_LIMIT=.TRUE., DT\_RESTART=300.0,  
DT\_SL3D=0.25/

&MISC HUMIDITY=30.0, TMPA=30.0/

&WIND SPEED=6.7, DIRECTION=90.0/

&MESH ID='Mesh01', IJK=75,52,25, XB=-15.736667,3.0,-10.85625,2.228125,0.0,6.3375/

&SPEC ID='WATER VAPOR'/

&PART ID='rods',

    SURF\_ID='brand',

    DRAG\_LAW='CYLINDER',

    QUANTITIES='PARTICLE DIAMETER','PARTICLE MASS','PARTICLE TEMPERATURE',

    PROP\_ID='rod image'/

&PART ID='water drops',

    SPEC\_ID='WATER VAPOR',

DIAMETER=1500.0,  
MINIMUM\_DIAMETER=1400.0,  
MAXIMUM\_DIAMETER=2000.0,  
GAMMA\_D=2.1,  
QUANTITIES='PARTICLE TEMPERATURE','PARTICLE DIAMETER',  
AGE=30.0,  
SAMPLING\_FACTOR=100/

&REAC ID='Reaction1',  
FUEL='REAC\_FUEL',  
FORMULA='C6H10O5',  
SOOT\_YIELD=0.015/

&PROP ID='ln02',  
PART\_ID='water drops',  
OFFSET=0.08,  
PARTICLES\_PER\_SECOND=100000,  
FLOW\_RATE=1.89,  
PARTICLE\_VELOCITY=4.0,  
SPRAY\_ANGLE=0.0,45.0/

&DEVC ID='a nozzle', PROP\_ID='ln02', XYZ=-3.02,-4.15,2.8964, QUANTITY='TIME', SETPOINT=0.0/  
&DEVC ID='a nozzle01', PROP\_ID='ln02', XYZ=-3.02,-1.75,2.8964, QUANTITY='TIME', SETPOINT=0.0/  
&DEVC ID='a nozzle02', PROP\_ID='ln02', XYZ=-3.02,0.65,2.8964, QUANTITY='TIME', SETPOINT=0.0/  
&DEVC ID='a nozzle03', PROP\_ID='ln02', XYZ=-3.02,-6.55,2.8964, QUANTITY='TIME', SETPOINT=0.0/  
&DEVC ID='a nozzle04', PROP\_ID='ln02', XYZ=-3.02,-8.95,2.8964, QUANTITY='TIME', SETPOINT=0.0/  
&DEVC ID='a nozzle05', PROP\_ID='ln02', XYZ=-3.92,-9.73,2.8964, QUANTITY='TIME', SETPOINT=0.0/  
&DEVC ID='a nozzle06', PROP\_ID='ln02', XYZ=-6.32,-9.73,2.8964, QUANTITY='TIME', SETPOINT=0.0/  
&DEVC ID='a nozzle07', PROP\_ID='ln02', XYZ=-8.72,-9.73,2.8964, QUANTITY='TIME', SETPOINT=0.0/  
&DEVC ID='a nozzle08', PROP\_ID='ln02', XYZ=-11.12,-9.73,2.8964, QUANTITY='TIME', SETPOINT=0.0/

&DEVC ID='a nozzle09', PROP\_ID='ln02', XYZ=-13.52,-9.73,2.8964, QUANTITY='TIME', SETPOINT=0.0/

&MATL ID='Redwood',

SPECIFIC\_HEAT=1.76,

CONDUCTIVITY=0.26,

DENSITY=510.0,

EMISSIVITY=0.84/

&MATL ID='FiberSiding',

SPECIFIC\_HEAT=0.84,

CONDUCTIVITY=0.245,

DENSITY=1770.0,

EMISSIVITY=0.54/

&MATL ID='Shingles',

SPECIFIC\_HEAT=0.88,

CONDUCTIVITY=0.5,

DENSITY=2370.0,

EMISSIVITY=0.63/

&MATL ID='wood',

SPECIFIC\_HEAT=1.0,

CONDUCTIVITY=0.1,

DENSITY=440.0,

HEAT\_OF\_COMBUSTION=1.5E4,

N\_REACTIONS=1,

HEAT\_OF\_REACTION=1000.0,

MATL\_ID(1,1)='char',

NU\_MATL(1,1)=0.08,

SPEC\_ID(1,1)='REAC\_FUEL',

NU\_SPEC(1,1)=0.92,

REFERENCE\_TEMPERATURE=300.0/

&MATL ID='char',  
SPECIFIC\_HEAT=1.0,  
CONDUCTIVITY=0.1,  
DENSITY=71.0/

&SURF ID='Deck',  
RGB=255,14,18,  
MATL\_ID(1,1)='Redwood',  
MATL\_MASS\_FRACTION(1,1)=1.0,  
THICKNESS(1)=0.2/

&SURF ID='Siding',  
BACKING='VOID',  
MATL\_ID(1,1)='FiberSiding',  
MATL\_MASS\_FRACTION(1,1)=1.0,  
THICKNESS(1)=0.2/

&SURF ID='Roof',  
BACKING='VOID',  
MATL\_ID(1,1)='Shingles',  
MATL\_MASS\_FRACTION(1,1)=1.0,  
THICKNESS(1)=0.2/

&SURF ID='Global04',  
RGB=127,191,255/

&SURF ID='Global05',  
RGB=204,102,102/

&SURF ID='Global06',  
COLOR='WHITE'/

&SURF ID='Global11',  
RGB=255,191,127/

&SURF ID='brand',

MATL\_ID(1,1)='wood',  
MATL\_MASS\_FRACTION(1,1)=1.0,  
THICKNESS(1)=4.0E-3,  
GEOMETRY='CYLINDRICAL',  
LENGTH=0.0135,  
INNER\_RADIUS=0.0,  
EXTERNAL\_FLUX=50.0/

&INIT ID='Particle Cloud', PART\_ID='rods', N\_PARTICLES=24, DT\_INSERT=0.01, MASS\_PER\_TIME=0.1,  
XB=-15.7,3.0,-10.534162,2.2,6.2,6.3/

&OBST ID='AcDb3dSolid - BD', XB=-13.987911,-13.987911,-7.585156,-6.578666,0.0,1.014,  
RGB=102,204,153, SURF\_ID='Deck'/

&OBST ID='AcDb3dSolid - BD', XB=-13.987911,-13.987911,-4.817308,-3.810817,0.0,1.014,  
RGB=102,204,153, SURF\_ID='Deck'/

&OBST ID='AcDb3dSolid - BD', XB=-13.987911,-13.987911,-2.049459,-1.042969,0.0,1.014,  
RGB=102,204,153, SURF\_ID='Deck'/

&OBST ID='AcDb3dSolid - BD', XB=-13.987911,-13.987911,-9.598137,-7.585156,0.0,3.042,  
RGB=102,204,153, SURF\_ID='Deck'/

&OBST ID='AcDb3dSolid - BD', XB=-13.987911,-13.987911,-6.578666,-4.817308,0.0,3.042,  
RGB=102,204,153, SURF\_ID='Deck'/

&OBST ID='AcDb3dSolid - BD', XB=-13.987911,-13.987911,-3.810817,-2.049459,0.0,3.042,  
RGB=102,204,153, SURF\_ID='Deck'/

&OBST ID='AcDb3dSolid - BD', XB=-13.987911,-13.987911,-1.042969,1.221635,0.0,3.042,  
RGB=102,204,153, SURF\_ID='Deck'/

&OBST ID='AcDb3dSolid - BD', XB=-13.987911,-13.987911,-7.585156,-6.578666,1.7745,3.042,  
RGB=102,204,153, SURF\_ID='Deck'/

&OBST ID='AcDb3dSolid - BD', XB=-13.987911,-13.987911,-4.817308,-3.810817,1.7745,3.042,  
RGB=102,204,153, SURF\_ID='Deck'/

&OBST ID='AcDb3dSolid - BD', XB=-13.987911,-13.987911,-2.049459,-1.042969,1.7745,3.042,  
RGB=102,204,153, SURF\_ID='Deck'/

&OBST ID='AcDb3dSolid - BE', XB=-13.987911,-11.739511,-9.598137,-9.346514,0.0,3.042,  
RGB=102,204,153, SURF\_ID='Siding'/

&OBST ID='AcDb3dSolid - BE', XB=-11.739511,-10.740222,-9.598137,-9.346514,0.0,1.014,  
RGB=102,204,153, SURF\_ID='Siding'/

&OBST ID='AcDb3dSolid - BE', XB=-11.739511,-10.740222,-9.598137,-9.346514,1.7745,3.042,  
RGB=102,204,153, SURF\_ID='Siding'/

&OBST ID='AcDb3dSolid - BE', XB=-10.740222,-9.241289,-9.598137,-9.346514,0.0,3.042,  
RGB=102,204,153, SURF\_ID='Siding'/

&OBST ID='AcDb3dSolid - BE', XB=-9.241289,-7.742356,-9.598137,-9.346514,0.0,0.507,  
RGB=102,204,153, SURF\_ID='Siding'/

&OBST ID='AcDb3dSolid - BE', XB=-9.241289,-7.742356,-9.598137,-9.346514,2.028,3.042,  
RGB=102,204,153, SURF\_ID='Siding'/

&OBST ID='AcDb3dSolid - BE', XB=-7.742356,-6.493245,-9.598137,-9.346514,0.0,3.042,  
RGB=102,204,153, SURF\_ID='Siding'/

&OBST ID='AcDb3dSolid - BE', XB=-6.493245,-5.493956,-9.598137,-9.346514,0.0,1.014,  
RGB=102,204,153, SURF\_ID='Siding'/

&OBST ID='AcDb3dSolid - BE', XB=-6.493245,-5.493956,-9.598137,-9.346514,1.7745,3.042,  
RGB=102,204,153, SURF\_ID='Siding'/

&OBST ID='AcDb3dSolid - BE', XB=-5.493956,-3.245556,-9.598137,-9.346514,0.0,3.042,  
RGB=102,204,153, SURF\_ID='Siding'/

&OBST ID='AcDb3dSolid - BF', XB=-3.245556,-3.245556,-2.049459,-1.042969,0.0,1.014,  
RGB=102,204,153, SURF\_ID='Siding'/

&OBST ID='AcDb3dSolid - BF', XB=-3.245556,-3.245556,-9.346514,-7.585156,0.0,3.042,  
RGB=102,204,153, SURF\_ID='Siding'/

&OBST ID='AcDb3dSolid - BF', XB=-3.245556,-3.245556,-5.823798,-2.049459,0.0,3.042,  
RGB=102,204,153, SURF\_ID='Siding'/

&OBST ID='AcDb3dSolid - BF', XB=-3.245556,-3.245556,-1.042969,1.221635,0.0,3.042,  
RGB=102,204,153, SURF\_ID='Siding'/

&OBST ID='AcDb3dSolid - BF', XB=-3.245556,-3.245556,-2.049459,-1.042969,1.7745,3.042,  
RGB=102,204,153, SURF\_ID='Siding'/

&OBST ID='AcDb3dSolid - BF', XB=-3.245556,-3.245556,-7.585156,-5.823798,2.028,3.042,  
RGB=102,204,153, SURF\_ID='Siding'/

&OBST ID='AcDb3dSolid - CO', XB=-13.987911,-11.739511,1.221635,1.221635,0.0,3.042,  
RGB=102,204,153, SURF\_ID='Deck'/

&OBST ID='AcDb3dSolid - CO', XB=-11.739511,-10.740222,1.221635,1.221635,0.0,1.014,  
RGB=102,204,153, SURF\_ID='Deck'/

&OBST ID='AcDb3dSolid - C0', XB=-11.739511,-10.740222,1.221635,1.221635,1.7745,3.042,  
RGB=102,204,153, SURF\_ID='Deck'/

&OBST ID='AcDb3dSolid - C0', XB=-10.740222,-6.493245,1.221635,1.221635,0.0,3.042,  
RGB=102,204,153, SURF\_ID='Deck'/

&OBST ID='AcDb3dSolid - C0', XB=-6.493245,-5.493956,1.221635,1.221635,2.028,3.042,  
RGB=102,204,153, SURF\_ID='Deck'/

&OBST ID='AcDb3dSolid - C0', XB=-5.493956,-3.245556,1.221635,1.221635,0.0,3.042, RGB=102,204,153,  
SURF\_ID='Deck'/

&OBST ID='AcDb3dSolid - 219', XB=-3.245556,1.251244,-9.598137,-4.565685,0.0,0.0, RGB=102,0,204,  
SURF\_ID='Deck'/

&OBST ID='AcDb3dSolid - C4', XB=-14.237734,-13.987911,-9.346514,1.221635,3.042,3.2955,  
RGB=0,204,204, SURF\_ID='Roof'/

&OBST ID='AcDb3dSolid - C4', XB=-14.237734,-2.995733,-9.84976,-9.346514,3.042,3.2955,  
RGB=0,204,204, SURF\_ID='Roof'/

&OBST ID='AcDb3dSolid - C4', XB=-14.237734,-2.995733,1.221635,1.473257,3.042,3.2955,  
RGB=0,204,204, SURF\_ID='Roof'/

&OBST ID='AcDb3dSolid - C4', XB=-13.987911,-13.738089,-9.346514,0.970012,3.042,3.549,  
RGB=0,204,204, SURF\_ID='Roof'/

&OBST ID='AcDb3dSolid - C4', XB=-13.987911,-3.245556,0.970012,1.221635,3.042,3.549,  
RGB=0,204,204, SURF\_ID='Roof'/

&OBST ID='AcDb3dSolid - C4', XB=-13.738089,-13.488267,-8.843269,0.718389,3.2955,3.549,  
RGB=0,204,204, SURF\_ID='Roof'/

&OBST ID='AcDb3dSolid - C4', XB=-13.738089,-3.495378,-9.346514,-8.843269,3.2955,3.549,  
RGB=0,204,204, SURF\_ID='Roof'/

&OBST ID='AcDb3dSolid - C4', XB=-13.738089,-3.495378,0.718389,0.970012,3.2955,3.549,  
RGB=0,204,204, SURF\_ID='Roof'/

&OBST ID='AcDb3dSolid - C4', XB=-13.488267,-13.238445,-8.843269,0.466767,3.2955,3.8025,  
RGB=0,204,204, SURF\_ID='Roof'/

&OBST ID='AcDb3dSolid - C4', XB=-13.488267,-3.7452,0.466767,0.718389,3.2955,3.8025,  
RGB=0,204,204, SURF\_ID='Roof'/

&OBST ID='AcDb3dSolid - C4', XB=-13.238445,-12.988623,-8.340024,0.215144,3.549,3.8025,  
RGB=0,204,204, SURF\_ID='Roof'/

&OBST ID='AcDb3dSolid - C4', XB=-13.238445,-3.995022,-8.843269,-8.340024,3.549,3.8025,  
RGB=0,204,204, SURF\_ID='Roof'/



&OBST ID='AcDb3dSolid - C4', XB=-13.238445,-3.995022,0.215144,0.466767,3.549,3.8025,  
RGB=0,204,204, SURF\_ID='Roof'/

&OBST ID='AcDb3dSolid - C4', XB=-12.988623,-12.7388,-8.340024,-0.036478,3.549,4.056,  
RGB=0,204,204, SURF\_ID='Roof'/

&OBST ID='AcDb3dSolid - C4', XB=-12.988623,-4.244845,-0.036478,0.215144,3.549,4.056,  
RGB=0,204,204, SURF\_ID='Roof'/

&OBST ID='AcDb3dSolid - C4', XB=-12.7388,-12.488978,-7.836779,-0.288101,3.8025,4.056,  
RGB=0,204,204, SURF\_ID='Roof'/

&OBST ID='AcDb3dSolid - C4', XB=-12.7388,-4.494667,-8.340024,-7.836779,3.8025,4.056,  
RGB=0,204,204, SURF\_ID='Roof'/

&OBST ID='AcDb3dSolid - C4', XB=-12.7388,-4.494667,-0.288101,-0.036478,3.8025,4.056,  
RGB=0,204,204, SURF\_ID='Roof'/

&OBST ID='AcDb3dSolid - C4', XB=-12.488978,-12.239156,-7.836779,-0.539724,3.8025,4.3095,  
RGB=0,204,204, SURF\_ID='Roof'/

&OBST ID='AcDb3dSolid - C4', XB=-12.488978,-4.744489,-0.539724,-0.288101,3.8025,4.3095,  
RGB=0,204,204, SURF\_ID='Roof'/

&OBST ID='AcDb3dSolid - C4', XB=-12.239156,-11.989334,-7.333534,-0.791346,4.056,4.3095,  
RGB=0,204,204, SURF\_ID='Roof'/

&OBST ID='AcDb3dSolid - C4', XB=-12.239156,-4.994311,-7.836779,-7.333534,4.056,4.3095,  
RGB=0,204,204, SURF\_ID='Roof'/

&OBST ID='AcDb3dSolid - C4', XB=-12.239156,-4.994311,-0.791346,-0.539724,4.056,4.3095,  
RGB=0,204,204, SURF\_ID='Roof'/

&OBST ID='AcDb3dSolid - C4', XB=-11.989334,-11.739511,-7.333534,-1.042969,4.056,4.563,  
RGB=0,204,204, SURF\_ID='Roof'/

&OBST ID='AcDb3dSolid - C4', XB=-11.989334,-5.244133,-1.042969,-0.791346,4.056,4.563,  
RGB=0,204,204, SURF\_ID='Roof'/

&OBST ID='AcDb3dSolid - C4', XB=-11.739511,-11.489689,-6.830288,-1.294591,4.3095,4.563,  
RGB=0,204,204, SURF\_ID='Roof'/

&OBST ID='AcDb3dSolid - C4', XB=-11.739511,-5.493956,-7.333534,-6.830288,4.3095,4.563,  
RGB=0,204,204, SURF\_ID='Roof'/

&OBST ID='AcDb3dSolid - C4', XB=-11.739511,-5.493956,-1.294591,-1.042969,4.3095,4.563,  
RGB=0,204,204, SURF\_ID='Roof'/

&OBST ID='AcDb3dSolid - C4', XB=-11.489689,-11.239867,-6.830288,-1.546214,4.3095,4.8165,  
RGB=0,204,204, SURF\_ID='Roof'/

&OBST ID='AcDb3dSolid - C4', XB=-11.489689,-5.743778,-1.546214,-1.294591,4.3095,4.8165,  
RGB=0,204,204, SURF\_ID='Roof'/

&OBST ID='AcDb3dSolid - C4', XB=-11.239867,-10.990045,-6.327043,-1.797837,4.563,4.8165,  
RGB=0,204,204, SURF\_ID='Roof'/

&OBST ID='AcDb3dSolid - C4', XB=-11.239867,-5.9936,-6.830288,-6.327043,4.563,4.8165,  
RGB=0,204,204, SURF\_ID='Roof'/

&OBST ID='AcDb3dSolid - C4', XB=-11.239867,-5.9936,-1.797837,-1.546214,4.563,4.8165,  
RGB=0,204,204, SURF\_ID='Roof'/

&OBST ID='AcDb3dSolid - C4', XB=-10.990045,-10.740222,-6.327043,-2.049459,4.563,5.07,  
RGB=0,204,204, SURF\_ID='Roof'/

&OBST ID='AcDb3dSolid - C4', XB=-10.990045,-6.243422,-2.049459,-1.797837,4.563,5.07,  
RGB=0,204,204, SURF\_ID='Roof'/

&OBST ID='AcDb3dSolid - C4', XB=-10.740222,-10.4904,-5.823798,-2.301082,4.8165,5.07,  
RGB=0,204,204, SURF\_ID='Roof'/

&OBST ID='AcDb3dSolid - C4', XB=-10.740222,-6.493245,-6.327043,-5.823798,4.8165,5.07,  
RGB=0,204,204, SURF\_ID='Roof'/

&OBST ID='AcDb3dSolid - C4', XB=-10.740222,-6.493245,-2.301082,-2.049459,4.8165,5.07,  
RGB=0,204,204, SURF\_ID='Roof'/

&OBST ID='AcDb3dSolid - C4', XB=-10.4904,-10.240578,-5.823798,-2.552704,4.8165,5.3235,  
RGB=0,204,204, SURF\_ID='Roof'/

&OBST ID='AcDb3dSolid - C4', XB=-10.4904,-6.743067,-2.552704,-2.301082,4.8165,5.3235,  
RGB=0,204,204, SURF\_ID='Roof'/

&OBST ID='AcDb3dSolid - C4', XB=-10.240578,-9.990756,-5.320553,-2.804327,5.07,5.3235,  
RGB=0,204,204, SURF\_ID='Roof'/

&OBST ID='AcDb3dSolid - C4', XB=-10.240578,-6.992889,-5.823798,-5.320553,5.07,5.3235,  
RGB=0,204,204, SURF\_ID='Roof'/

&OBST ID='AcDb3dSolid - C4', XB=-10.240578,-6.992889,-2.804327,-2.552704,5.07,5.3235,  
RGB=0,204,204, SURF\_ID='Roof'/

&OBST ID='AcDb3dSolid - C4', XB=-9.990756,-9.740934,-5.320553,-3.05595,5.07,5.577, RGB=0,204,204,  
SURF\_ID='Roof'/

&OBST ID='AcDb3dSolid - C4', XB=-9.990756,-7.242711,-3.05595,-2.804327,5.07,5.577, RGB=0,204,204,  
SURF\_ID='Roof'/

&OBST ID='AcDb3dSolid - C4', XB=-9.740934,-9.491111,-4.817308,-3.307572,5.3235,5.577,  
RGB=0,204,204, SURF\_ID='Roof'/

&OBST ID='AcDb3dSolid - C4', XB=-9.740934,-7.492534,-5.320553,-4.817308,5.3235,5.577,  
RGB=0,204,204, SURF\_ID='Roof'/

&OBST ID='AcDb3dSolid - C4', XB=-9.740934,-7.492534,-3.307572,-3.05595,5.3235,5.577,  
RGB=0,204,204, SURF\_ID='Roof'/

&OBST ID='AcDb3dSolid - C4', XB=-9.491111,-9.241289,-4.817308,-3.559195,5.3235,5.8305,  
RGB=0,204,204, SURF\_ID='Roof'/

&OBST ID='AcDb3dSolid - C4', XB=-9.491111,-7.742356,-3.559195,-3.307572,5.3235,5.8305,  
RGB=0,204,204, SURF\_ID='Roof'/

&OBST ID='AcDb3dSolid - C4', XB=-9.241289,-8.991467,-4.314062,-3.810817,5.577,5.8305,  
RGB=0,204,204, SURF\_ID='Roof'/

&OBST ID='AcDb3dSolid - C4', XB=-9.241289,-7.992178,-4.817308,-4.314062,5.577,5.8305,  
RGB=0,204,204, SURF\_ID='Roof'/

&OBST ID='AcDb3dSolid - C4', XB=-9.241289,-7.992178,-3.810817,-3.559195,5.577,5.8305,  
RGB=0,204,204, SURF\_ID='Roof'/

&OBST ID='AcDb3dSolid - C4', XB=-8.991467,-8.741645,-4.314062,-4.06244,5.577,6.084,  
RGB=0,204,204, SURF\_ID='Roof'/

&OBST ID='AcDb3dSolid - C4', XB=-8.991467,-8.242,-4.06244,-3.810817,5.577,6.084, RGB=0,204,204,  
SURF\_ID='Roof'/

&OBST ID='AcDb3dSolid - C4', XB=-8.741645,-8.491822,-4.314062,-4.06244,5.8305,6.084,  
RGB=0,204,204, SURF\_ID='Roof'/

&OBST ID='AcDb3dSolid - C4', XB=-8.491822,-8.242,-4.314062,-4.06244,5.577,6.084, RGB=0,204,204,  
SURF\_ID='Roof'/

&OBST ID='AcDb3dSolid - C4', XB=-8.242,-7.992178,-4.314062,-3.810817,5.577,5.8305, RGB=0,204,204,  
SURF\_ID='Roof'/

&OBST ID='AcDb3dSolid - C4', XB=-7.992178,-7.742356,-4.817308,-3.559195,5.3235,5.8305,  
RGB=0,204,204, SURF\_ID='Roof'/

&OBST ID='AcDb3dSolid - C4', XB=-7.742356,-7.492534,-4.817308,-3.307572,5.3235,5.577,  
RGB=0,204,204, SURF\_ID='Roof'/

&OBST ID='AcDb3dSolid - C4', XB=-7.492534,-7.242711,-5.320553,-3.05595,5.07,5.577, RGB=0,204,204,  
SURF\_ID='Roof'/

&OBST ID='AcDb3dSolid - C4', XB=-7.242711,-6.992889,-5.320553,-2.804327,5.07,5.3235,  
RGB=0,204,204, SURF\_ID='Roof'/

&OBST ID='AcDb3dSolid - C4', XB=-6.992889,-6.743067,-5.823798,-2.552704,4.8165,5.3235,  
RGB=0,204,204, SURF\_ID='Roof'/

&OBST ID='AcDb3dSolid - C4', XB=-6.743067,-6.493245,-5.823798,-2.301082,4.8165,5.07,  
RGB=0,204,204, SURF\_ID='Roof'/

&OBST ID='AcDb3dSolid - C4', XB=-6.493245,-6.243422,-6.327043,-2.049459,4.563,5.07,  
RGB=0,204,204, SURF\_ID='Roof'/

&OBST ID='AcDb3dSolid - C4', XB=-6.243422,-5.9936,-6.327043,-1.797837,4.563,4.8165,  
RGB=0,204,204, SURF\_ID='Roof'/

&OBST ID='AcDb3dSolid - C4', XB=-5.9936,-5.743778,-6.830288,-1.546214,4.3095,4.8165,  
RGB=0,204,204, SURF\_ID='Roof'/

&OBST ID='AcDb3dSolid - C4', XB=-5.743778,-5.493956,-6.830288,-1.294591,4.3095,4.563,  
RGB=0,204,204, SURF\_ID='Roof'/

&OBST ID='AcDb3dSolid - C4', XB=-5.493956,-5.244133,-7.333534,-1.042969,4.056,4.563,  
RGB=0,204,204, SURF\_ID='Roof'/

&OBST ID='AcDb3dSolid - C4', XB=-5.244133,-4.994311,-7.333534,-0.791346,4.056,4.3095,  
RGB=0,204,204, SURF\_ID='Roof'/

&OBST ID='AcDb3dSolid - C4', XB=-4.994311,-4.744489,-7.836779,-0.539724,3.8025,4.3095,  
RGB=0,204,204, SURF\_ID='Roof'/

&OBST ID='AcDb3dSolid - C4', XB=-4.744489,-4.494667,-7.836779,-0.288101,3.8025,4.056,  
RGB=0,204,204, SURF\_ID='Roof'/

&OBST ID='AcDb3dSolid - C4', XB=-4.494667,-4.244845,-8.340024,-0.036478,3.549,4.056,  
RGB=0,204,204, SURF\_ID='Roof'/

&OBST ID='AcDb3dSolid - C4', XB=-4.244845,-3.995022,-8.340024,0.215144,3.549,3.8025,  
RGB=0,204,204, SURF\_ID='Roof'/

&OBST ID='AcDb3dSolid - C4', XB=-3.995022,-3.7452,-8.843269,0.466767,3.2955,3.8025,  
RGB=0,204,204, SURF\_ID='Roof'/

&OBST ID='AcDb3dSolid - C4', XB=-3.7452,-3.495378,-8.843269,0.718389,3.2955,3.549, RGB=0,204,204,  
SURF\_ID='Roof'/

&OBST ID='AcDb3dSolid - C4', XB=-3.495378,-3.245556,-9.346514,0.970012,3.042,3.549,  
RGB=0,204,204, SURF\_ID='Roof'/

&OBST ID='AcDb3dSolid - C4', XB=-3.245556,-2.995733,-9.346514,1.221635,3.042,3.2955,  
RGB=0,204,204, SURF\_ID='Roof'/

&OBST ID='AcDbBlockReference - D0', XB=-13.987911,-13.987911,-2.049459,-1.797837,1.014,1.7745,  
RGB=127,191,255, SURF\_ID='Global04'/

&OBST ID='AcDbBlockReference - D0', XB=-13.987911,-13.987911,-1.797837,-1.294591,1.014,1.7745,  
RGB=127,191,255, SURF\_ID='Global04'/

&OBST ID='AcDbBlockReference - D0', XB=-13.987911,-13.987911,-1.294591,-1.042969,1.014,1.7745, RGB=127,191,255, SURF\_ID='Global04'/

&OBST ID='AcDbBlockReference - D1', XB=-13.987911,-13.987911,-4.817308,-4.565685,1.014,1.7745, RGB=127,191,255, SURF\_ID='Global04'/

&OBST ID='AcDbBlockReference - D1', XB=-13.987911,-13.987911,-4.565685,-3.810817,1.014,1.7745, RGB=127,191,255, SURF\_ID='Global04'/

&OBST ID='AcDbBlockReference - D2', XB=-13.987911,-13.987911,-7.585156,-7.333534,1.014,1.7745, RGB=127,191,255, SURF\_ID='Global04'/

&OBST ID='AcDbBlockReference - D2', XB=-13.987911,-13.987911,-7.333534,-6.578666,1.014,1.7745, RGB=127,191,255, SURF\_ID='Global04'/

&OBST ID='AcDbBlockReference - 6BE', XB=-3.495378,-3.245556,-2.049459,-1.042969,1.014,1.014, RGB=127,191,255, SURF\_ID='Global04'/

&OBST ID='AcDbBlockReference - 6BE', XB=-3.495378,-3.245556,-2.049459,-1.042969,1.7745,1.7745, RGB=127,191,255, SURF\_ID='Global04'/

&OBST ID='AcDbBlockReference - 6BE', XB=-3.495378,-3.245556,-2.049459,-2.049459,1.014,1.7745, RGB=127,191,255, SURF\_ID='Global04'/

&OBST ID='AcDbBlockReference - 6BE', XB=-3.495378,-3.245556,-1.797837,-1.797837,1.014,1.7745, RGB=127,191,255, SURF\_ID='Global04'/

&OBST ID='AcDbBlockReference - 6BE', XB=-3.495378,-3.245556,-1.546214,-1.546214,1.014,1.7745, RGB=127,191,255, SURF\_ID='Global04'/

&OBST ID='AcDbBlockReference - 6BE', XB=-3.495378,-3.245556,-1.294591,-1.294591,1.014,1.7745, RGB=127,191,255, SURF\_ID='Global04'/

&OBST ID='AcDbBlockReference - 6BE', XB=-3.495378,-3.245556,-1.042969,-1.042969,1.014,1.7745, RGB=127,191,255, SURF\_ID='Global04'/

&OBST ID='AcDbBlockReference - 6BE', XB=-3.495378,-3.495378,-2.049459,-1.797837,1.014,1.7745, RGB=127,191,255, SURF\_ID='Global04'/

&OBST ID='AcDbBlockReference - 6BE', XB=-3.495378,-3.495378,-1.294591,-1.042969,1.014,1.7745, RGB=127,191,255, SURF\_ID='Global04'/

&OBST ID='AcDbBlockReference - 6BE', XB=-3.245556,-3.245556,-2.049459,-1.797837,1.014,1.7745, RGB=127,191,255, SURF\_ID='Global04'/

&OBST ID='AcDbBlockReference - 6BE', XB=-3.245556,-3.245556,-1.797837,-1.294591,1.014,1.7745, RGB=127,191,255, SURF\_ID='Global04'/

&OBST ID='AcDbBlockReference - 6BE', XB=-3.245556,-3.245556,-1.294591,-1.042969,1.014,1.7745, RGB=127,191,255, SURF\_ID='Global04'/

&OBST ID='AcDbBlockReference - 6CD', XB=-11.739511,-10.740222,-9.598137,-9.346514,1.014,1.014,  
RGB=127,191,255, SURF\_ID='Global04'/

&OBST ID='AcDbBlockReference - 6CD', XB=-11.739511,-10.740222,-9.598137,-9.346514,1.7745,1.7745,  
RGB=127,191,255, SURF\_ID='Global04'/

&OBST ID='AcDbBlockReference - 6CD', XB=-11.739511,-11.489689,-9.346514,-9.346514,1.014,1.7745,  
RGB=127,191,255, SURF\_ID='Global04'/

&OBST ID='AcDbBlockReference - 6CD', XB=-11.489689,-10.740222,-9.346514,-9.346514,1.014,1.7745,  
RGB=127,191,255, SURF\_ID='Global04'/

&OBST ID='AcDbBlockReference - 6CD', XB=-11.739511,-11.739511,-9.598137,-9.346514,1.014,1.7745,  
RGB=127,191,255, SURF\_ID='Global04'/

&OBST ID='AcDbBlockReference - 6CD', XB=-11.239867,-11.239867,-9.598137,-9.346514,1.014,1.7745,  
RGB=127,191,255, SURF\_ID='Global04'/

&OBST ID='AcDbBlockReference - 6CD', XB=-10.740222,-10.740222,-9.598137,-9.346514,1.014,1.7745,  
RGB=127,191,255, SURF\_ID='Global04'/

&OBST ID='AcDbBlockReference - 6D2', XB=-5.743778,-5.493956,-9.598137,-9.346514,1.014,1.7745,  
RGB=127,191,255, SURF\_ID='Global04'/

&OBST ID='AcDbBlockReference - 6D2', XB=-6.493245,-5.743778,-9.598137,-9.346514,1.014,1.014,  
RGB=127,191,255, SURF\_ID='Global04'/

&OBST ID='AcDbBlockReference - 6D2', XB=-6.493245,-5.743778,-9.598137,-9.346514,1.7745,1.7745,  
RGB=127,191,255, SURF\_ID='Global04'/

&OBST ID='AcDbBlockReference - 6D2', XB=-6.493245,-5.743778,-9.346514,-9.346514,1.014,1.7745,  
RGB=127,191,255, SURF\_ID='Global04'/

&OBST ID='AcDbBlockReference - 6D2', XB=-6.493245,-6.493245,-9.598137,-9.346514,1.014,1.7745,  
RGB=127,191,255, SURF\_ID='Global04'/

&OBST ID='AcDbBlockReference - 6D2', XB=-5.9936,-5.9936,-9.598137,-9.346514,1.014,1.7745,  
RGB=127,191,255, SURF\_ID='Global04'/

&OBST ID='AcDbBlockReference - 6D7', XB=-11.739511,-11.489689,1.221635,1.221635,1.014,1.7745,  
RGB=127,191,255, SURF\_ID='Global04'/

&OBST ID='AcDbBlockReference - 6D7', XB=-11.489689,-10.740222,1.221635,1.221635,1.014,1.7745,  
RGB=127,191,255, SURF\_ID='Global04'/

&OBST ID='AcDbBlockReference - 6F0', XB=-9.491111,-7.742356,-10.101382,-9.598137,0.507,0.507,  
RGB=127,191,255, SURF\_ID='Global04'/

&OBST ID='AcDbBlockReference - 6F0', XB=-9.491111,-7.742356,-10.101382,-9.598137,2.028,2.028,  
RGB=127,191,255, SURF\_ID='Global04'/

&OBST ID='AcDbBlockReference - 6F0', XB=-9.491111,-7.742356,-10.101382,-9.598137,2.2815,2.2815,  
RGB=127,191,255, SURF\_ID='Global04'/

&OBST ID='AcDbBlockReference - 6F0', XB=-9.241289,-7.742356,-9.598137,-9.346514,0.507,0.507,  
RGB=127,191,255, SURF\_ID='Global04'/

&OBST ID='AcDbBlockReference - 6F0', XB=-9.241289,-7.742356,-9.598137,-9.346514,2.028,2.028,  
RGB=127,191,255, SURF\_ID='Global04'/

&OBST ID='AcDbBlockReference - 6F0', XB=-9.491111,-9.241289,-10.101382,-10.101382,0.507,2.2815,  
RGB=127,191,255, SURF\_ID='Global04'/

&OBST ID='AcDbBlockReference - 6F0', XB=-9.491111,-9.241289,-9.598137,-9.598137,0.507,2.2815,  
RGB=127,191,255, SURF\_ID='Global04'/

&OBST ID='AcDbBlockReference - 6F0', XB=-9.241289,-7.992178,-10.101382,-10.101382,0.507,0.7605,  
RGB=127,191,255, SURF\_ID='Global04'/

&OBST ID='AcDbBlockReference - 6F0', XB=-9.241289,-7.992178,-10.101382,-10.101382,0.7605,2.028,  
RGB=127,191,255, SURF\_ID='Global04'/

&OBST ID='AcDbBlockReference - 6F0', XB=-9.241289,-7.992178,-10.101382,-10.101382,2.028,2.2815,  
RGB=127,191,255, SURF\_ID='Global04'/

&OBST ID='AcDbBlockReference - 6F0', XB=-9.241289,-7.742356,-9.598137,-9.598137,2.028,2.2815,  
RGB=127,191,255, SURF\_ID='Global04'/

&OBST ID='AcDbBlockReference - 6F0', XB=-7.992178,-7.742356,-10.101382,-10.101382,0.507,2.2815,  
RGB=127,191,255, SURF\_ID='Global04'/

&OBST ID='AcDbBlockReference - 6F0', XB=-9.491111,-9.491111,-10.101382,-9.598137,0.507,0.7605,  
RGB=127,191,255, SURF\_ID='Global04'/

&OBST ID='AcDbBlockReference - 6F0', XB=-9.491111,-9.491111,-10.101382,-9.598137,0.7605,2.028,  
RGB=127,191,255, SURF\_ID='Global04'/

&OBST ID='AcDbBlockReference - 6F0', XB=-9.491111,-9.491111,-10.101382,-9.598137,2.028,2.2815,  
RGB=127,191,255, SURF\_ID='Global04'/

&OBST ID='AcDbBlockReference - 6F0', XB=-9.241289,-9.241289,-9.598137,-9.346514,0.507,2.028,  
RGB=127,191,255, SURF\_ID='Global04'/

&OBST ID='AcDbBlockReference - 6F0', XB=-7.742356,-7.742356,-10.101382,-9.598137,0.507,0.7605,  
RGB=127,191,255, SURF\_ID='Global04'/

&OBST ID='AcDbBlockReference - 6F0', XB=-7.742356,-7.742356,-9.598137,-9.346514,0.507,2.028,  
RGB=127,191,255, SURF\_ID='Global04'/

&OBST ID='AcDbBlockReference - 6F0', XB=-7.742356,-7.742356,-10.101382,-9.598137,0.7605,2.028,  
RGB=127,191,255, SURF\_ID='Global04'/

&OBST ID='AcDbBlockReference - 6F0', XB=-7.742356,-7.742356,-10.101382,-9.598137,2.028,2.2815, RGB=127,191,255, SURF\_ID='Global04'/

&OBST ID='AcDbBlockReference - EA', XB=-13.987911,-13.738089,-7.585156,-6.578666,0.7605,1.014, RGB=204,102,102, SURF\_ID='Global05'/

&OBST ID='AcDbBlockReference - EF', XB=-13.987911,-13.987911,-7.333534,-6.578666,0.7605,1.014, RGB=204,102,102, SURF\_ID='Global05'/

&OBST ID='AcDbBlockReference - EF', XB=-13.987911,-13.987911,-7.585156,-7.333534,0.7605,1.7745, RGB=204,102,102, SURF\_ID='Global05'/

&OBST ID='AcDbBlockReference - F2', XB=-13.987911,-13.738089,-4.817308,-3.810817,0.7605,1.014, RGB=204,102,102, SURF\_ID='Global05'/

&OBST ID='AcDbBlockReference - F3', XB=-13.987911,-13.987911,-4.817308,-3.810817,0.7605,1.014, RGB=204,102,102, SURF\_ID='Global05'/

&OBST ID='AcDbBlockReference - F6', XB=-13.987911,-13.738089,-2.049459,-1.042969,0.7605,1.014, RGB=204,102,102, SURF\_ID='Global05'/

&OBST ID='AcDbBlockReference - F7', XB=-13.987911,-13.987911,-2.049459,-1.042969,0.7605,1.014, RGB=204,102,102, SURF\_ID='Global05'/

&OBST ID='AcDbBlockReference - 6C7', XB=-3.495378,-3.245556,-2.049459,-1.042969,0.7605,1.014, RGB=204,102,102, SURF\_ID='Global05'/

&OBST ID='AcDbBlockReference - 6C7', XB=-3.495378,-3.245556,-2.049459,-1.042969,1.7745,1.7745, RGB=204,102,102, SURF\_ID='Global05'/

&OBST ID='AcDbBlockReference - 6C7', XB=-3.495378,-3.245556,-2.049459,-2.049459,1.014,1.7745, RGB=204,102,102, SURF\_ID='Global05'/

&OBST ID='AcDbBlockReference - 6C7', XB=-3.495378,-3.245556,-1.042969,-1.042969,1.014,1.7745, RGB=204,102,102, SURF\_ID='Global05'/

&OBST ID='AcDbBlockReference - 6CC', XB=-3.245556,-3.245556,-2.049459,-1.042969,0.7605,1.014, RGB=204,102,102, SURF\_ID='Global05'/

&OBST ID='AcDbBlockReference - 6D0', XB=-11.739511,-10.740222,-9.346514,-9.346514,0.7605,1.014, RGB=204,102,102, SURF\_ID='Global05'/

&OBST ID='AcDbBlockReference - 6D1', XB=-11.739511,-10.740222,-9.598137,-9.598137,0.7605,1.014, RGB=204,102,102, SURF\_ID='Global05'/

&OBST ID='AcDbBlockReference - 6D5', XB=-6.493245,-5.493956,-9.346514,-9.346514,0.7605,1.014, RGB=204,102,102, SURF\_ID='Global05'/

&OBST ID='AcDbBlockReference - 6D6', XB=-6.493245,-5.743778,-9.598137,-9.598137,0.7605,1.014, RGB=204,102,102, SURF\_ID='Global05'/



&OBST ID='AcDbBlockReference - 6D6', XB=-5.743778,-5.493956,-9.598137,-9.598137,0.7605,1.7745, RGB=204,102,102, SURF\_ID='Global05'/

&OBST ID='AcDbBlockReference - 6DA', XB=-11.739511,-10.740222,0.970012,1.221635,0.7605,1.014, RGB=204,102,102, SURF\_ID='Global05'/

&OBST ID='AcDbBlockReference - 6DB', XB=-11.739511,-10.740222,1.221635,1.221635,0.7605,1.014, RGB=204,102,102, SURF\_ID='Global05'/

&OBST ID='AcDbBlockReference - 706', XB=-9.491111,-9.241289,-9.346514,-9.346514,0.507,2.2815, RGB=204,102,102, SURF\_ID='Global05'/

&OBST ID='AcDbBlockReference - 706', XB=-9.241289,-7.742356,-9.346514,-9.346514,2.028,2.2815, RGB=204,102,102, SURF\_ID='Global05'/

&OBST ID='AcDbPolyFaceMesh - F9', XB=-15.736667,3.0,-10.85625,2.228125,0.0,0.0, COLOR='WHITE', SURF\_ID='Global06'/

&OBST ID='AcDbBlockReference - 721', XB=-3.4,-3.3,-7.4,-6.8,0.0,0.2, RGB=255,191,127, SURF\_ID='Global11'/

&OBST ID='AcDbBlockReference - 721', XB=-3.4,-3.3,-6.6,-6.1,0.0,0.2, RGB=255,191,127, SURF\_ID='Global11'/

&OBST ID='AcDbBlockReference - 721', XB=-3.4,-3.3,-6.8,-6.6,0.0,2.0, RGB=255,191,127, SURF\_ID='Global11'/

&OBST ID='AcDbBlockReference - 721', XB=-3.4,-3.3,-6.1,-6.0,0.0,2.0, RGB=255,191,127, SURF\_ID='Global11'/

&OBST ID='AcDbBlockReference - 721', XB=-3.4,-3.3,-7.4,-6.8,1.9,2.0, RGB=255,191,127, SURF\_ID='Global11'/

&OBST ID='AcDbBlockReference - 721', XB=-3.4,-3.3,-6.6,-6.1,1.9,2.0, RGB=255,191,127, SURF\_ID='Global11'/

&OBST ID='AcDbBlockReference - 721', XB=-3.4,-3.3,-7.4,-7.4,0.2,1.9, RGB=255,191,127, SURF\_ID='Global11'/

&VENT ID='Mesh Vent: Mesh01 [XMIN]', SURF\_ID='OPEN', XB=-15.73,-15.73,-10.856,2.228,0.0,6.3375, COLOR='INVISIBLE'/

&VENT ID='Mesh Vent: Mesh01 [XMAX]', SURF\_ID='OPEN', XB=3.0,3.0,-10.856,2.228,0.0,6.3375, COLOR='INVISIBLE'/

&VENT ID='Mesh Vent: Mesh01 [YMIN]', SURF\_ID='OPEN', XB=-15.7366,3.0,-10.856,-10.856,0.0,6.3375, COLOR='INVISIBLE'/

&VENT ID='Mesh Vent: Mesh01 [YMAX]', SURF\_ID='OPEN', XB=-15.73,3.0,2.28,2.28,0.0,6.3375, COLOR='INVISIBLE'/

&VENT ID='Mesh Vent: Mesh01 [ZMAX]', SURF\_ID='OPEN', XB=-15.73,3.0,-10.856,2.228,6.3375,6.3375,  
IOR=3, COLOR='INVISIBLE'/

&SLCF QUANTITY='TEMPERATURE', VECTOR=.TRUE., PBY=-4.133165/

&SLCF QUANTITY='VELOCITY', VECTOR=.TRUE., PBZ=-4.133165/

&DEVC ID='Mass\_VOLUME INTEGRAL', QUANTITY='MPUV', PART\_ID='rods', STATISTICS='VOLUME  
INTEGRAL', XB=-1.0,3.0,-0.5,0.5,0.0,0.1/

&TAIL /

house\_rightscaleSprinkRotated.fds

Generated by PyroSim - Version 2018.2.0730

Nov 2, 2018 12:31:12 PM

-----User Section (not generated by PyroSim)-----

&PROP ID='rod image', SMOKEVIEW\_ID='tube', SMOKEVIEW\_PARAMETERS='D=0.008'/

-----PyroSim-generated Section-----

&HEAD CHID='house\_rightscaleSprinkRotated', TITLE='Firebrand House Attack'/

&TIME T\_END=1800.0/

&DUMP RENDER\_FILE='house\_rightscaleSprinkRotated.ge1', COLUMN\_DUMP\_LIMIT=.TRUE.,  
DT\_SL3D=0.25/

&MISC HUMIDITY=30.0, TMPA=30.0/

&WIND SPEED=6.7, DIRECTION=90.0/

&MESH ID='Mesh01-a-a', IJK=128,20,25, XB=-20.0,12.0,-15.0,-10.0,0.0,6.3375/

&MESH ID='Mesh01-a-b-a', IJK=208,96,50, XB=-20.0,6.0,-10.0,2.0,0.0,6.3375/

&MESH ID='Mesh01-a-b-b', IJK=24,48,25, XB=6.0,12.0,-10.0,2.0,0.0,6.3375/

&MESH ID='Mesh01-b', IJK=128,16,25, XB=-20.0,12.0,2.0,6.0,0.0,6.3375/

&SPEC ID='WATER VAPOR'/

&PART ID='rods',

    SURF\_ID='brand',

DRAG\_LAW='CYLINDER',  
QUANTITIES='PARTICLE DIAMETER','PARTICLE MASS','PARTICLE TEMPERATURE',  
PROP\_ID='rod image'/

&PART ID='water drops',

SPEC\_ID='WATER VAPOR',

DIAMETER=1500.0,

MINIMUM\_DIAMETER=1400.0,

MAXIMUM\_DIAMETER=2000.0,

GAMMA\_D=2.1,

QUANTITIES='PARTICLE TEMPERATURE','PARTICLE DIAMETER',

AGE=30.0,

SAMPLING\_FACTOR=100/

&REAC ID='Reaction1',

FUEL='REAC\_FUEL',

FORMULA='C6H10O5',

SOOT\_YIELD=0.015/

&PROP ID='lnO2',

PART\_ID='water drops',

OFFSET=0.08,

PARTICLES\_PER\_SECOND=100000,

FLOW\_RATE=1.89,

PARTICLE\_VELOCITY=4.0,

SPRAY\_ANGLE=0.0,45.0/

&DEVC ID='T01', QUANTITY='TEMPERATURE', XYZ=-3.212079,-4.901211,0.26/

&DEVC ID='T02', QUANTITY='TEMPERATURE', XYZ=-3.212079,-4.901211,1.0896/

&DEVC ID='T03', QUANTITY='TEMPERATURE', XYZ=-3.212079,-4.901211,2.0896/

&DEVC ID='T04', QUANTITY='TEMPERATURE', XYZ=-3.25,-4.901211,3.042/

&DEVC ID='Device', QUANTITY='TEMPERATURE', XYZ=-3.212079,-4.901211,0.26/  
&DEVC ID='Device01', QUANTITY='TEMPERATURE', XYZ=-0.957309,-4.901505,0.26/  
&DEVC ID='Device02', QUANTITY='TEMPERATURE', XYZ=-2.0,-4.875,0.26/  
&DEVC ID='Device03', QUANTITY='TEMPERATURE', XYZ=-0.965087,-7.914401,0.26/  
&DEVC ID='Device04', QUANTITY='TEMPERATURE', XYZ=-5.461887,-7.914401,0.05/  
&DEVC ID='Device07', QUANTITY='TEMPERATURE', XYZ=-2.961887,-7.914327,0.26/  
&DEVC ID='Device08', QUANTITY='TEMPERATURE', XYZ=-2.961887,-6.914327,0.26/  
&DEVC ID='Device09', QUANTITY='TEMPERATURE', XYZ=-2.961887,-5.914327,0.26/  
&DEVC ID='a nozzle', PROP\_ID='ln02', XYZ=-3.02,-4.15,2.8964, ORIENTATION=1.0,0.0,0.0,  
QUANTITY='TIME', SETPOINT=0.0/  
&DEVC ID='a nozzle01', PROP\_ID='ln02', XYZ=-3.02,-1.75,2.8964, ORIENTATION=1.0,0.0,0.0,  
QUANTITY='TIME', SETPOINT=0.0/  
&DEVC ID='a nozzle02', PROP\_ID='ln02', XYZ=-3.02,0.65,2.8964, ORIENTATION=1.0,0.0,0.0,  
QUANTITY='TIME', SETPOINT=0.0/  
&DEVC ID='a nozzle03', PROP\_ID='ln02', XYZ=-3.02,-6.55,2.8964, ORIENTATION=1.0,0.0,0.0,  
QUANTITY='TIME', SETPOINT=0.0/  
&DEVC ID='a nozzle04', PROP\_ID='ln02', XYZ=-3.02,-8.95,2.8964, ORIENTATION=1.0,0.0,0.0,  
QUANTITY='TIME', SETPOINT=0.0/  
&DEVC ID='a nozzle05', PROP\_ID='ln02', XYZ=-3.92,-9.73,2.8964, ORIENTATION=0.0,-1.0,0.0,  
QUANTITY='TIME', SETPOINT=0.0/  
&DEVC ID='a nozzle06', PROP\_ID='ln02', XYZ=-6.32,-9.73,2.8964, ORIENTATION=0.0,-1.0,0.0,  
QUANTITY='TIME', SETPOINT=0.0/  
&DEVC ID='a nozzle07', PROP\_ID='ln02', XYZ=-8.72,-9.73,2.8964, ORIENTATION=0.0,-1.0,0.0,  
QUANTITY='TIME', SETPOINT=0.0/  
&DEVC ID='a nozzle08', PROP\_ID='ln02', XYZ=-11.12,-9.73,2.8964, ORIENTATION=0.0,-1.0,0.0,  
QUANTITY='TIME', SETPOINT=0.0/  
&DEVC ID='a nozzle09', PROP\_ID='ln02', XYZ=-13.52,-9.73,2.8964, ORIENTATION=0.0,-1.0,0.0,  
QUANTITY='TIME', SETPOINT=0.0/  
&DEVC ID='a nozzle10', PROP\_ID='ln02', XYZ=-3.92,1.57,2.8964, ORIENTATION=0.0,1.0,0.0,  
QUANTITY='TIME', SETPOINT=0.0/  
&DEVC ID='a nozzle11', PROP\_ID='ln02', XYZ=-6.32,1.57,2.8964, ORIENTATION=0.0,1.0,0.0,  
QUANTITY='TIME', SETPOINT=0.0/

&DEVC ID='a nozzle12', PROP\_ID='ln02', XYZ=-8.72,1.57,2.8964, ORIENTATION=0.0,1.0,0.0,  
QUANTITY='TIME', SETPOINT=0.0/

&DEVC ID='a nozzle13', PROP\_ID='ln02', XYZ=-11.12,1.57,2.8964, ORIENTATION=0.0,1.0,0.0,  
QUANTITY='TIME', SETPOINT=0.0/

&DEVC ID='a nozzle14', PROP\_ID='ln02', XYZ=-13.52,1.57,2.8964, ORIENTATION=0.0,1.0,0.0,  
QUANTITY='TIME', SETPOINT=0.0/

&DEVC ID='a nozzle15', PROP\_ID='ln02', XYZ=-14.22,-4.15,2.8964, ORIENTATION=1.0,0.0,0.0,  
QUANTITY='TIME', SETPOINT=0.0/

&DEVC ID='a nozzle16', PROP\_ID='ln02', XYZ=-14.22,-1.75,2.8964, ORIENTATION=1.0,0.0,0.0,  
QUANTITY='TIME', SETPOINT=0.0/

&DEVC ID='a nozzle17', PROP\_ID='ln02', XYZ=-14.22,0.65,2.8964, ORIENTATION=1.0,0.0,0.0,  
QUANTITY='TIME', SETPOINT=0.0/

&DEVC ID='a nozzle18', PROP\_ID='ln02', XYZ=-14.22,-6.55,2.8964, ORIENTATION=1.0,0.0,0.0,  
QUANTITY='TIME', SETPOINT=0.0/

&DEVC ID='a nozzle19', PROP\_ID='ln02', XYZ=-14.22,-8.95,2.8964, ORIENTATION=1.0,0.0,0.0,  
QUANTITY='TIME', SETPOINT=0.0/

&DEVC ID='D01', QUANTITY='DENSITY', XYZ=-3.21208,-4.90121,0.2466/

&DEVC ID='D02', QUANTITY='TEMPERATURE', XYZ=-3.21208,-4.90121,1.2466/

&DEVC ID='D03', QUANTITY='TEMPERATURE', XYZ=-3.21208,-4.90121,2.2466/

&DEVC ID='D04', QUANTITY='TEMPERATURE', XYZ=-3.25,-4.90121,3.042/

&MATL ID='Shingles',

SPECIFIC\_HEAT=0.88,

CONDUCTIVITY=0.5,

DENSITY=2370.0,

EMISSIVITY=0.63/

&MATL ID='wood',

SPECIFIC\_HEAT=1.0,

CONDUCTIVITY=0.1,

DENSITY=440.0,

HEAT\_OF\_COMBUSTION=1.5E4,

N\_REACTIONS=1,

HEAT\_OF\_REACTION=1000.0,  
MATL\_ID(1,1)='char',  
NU\_MATL(1,1)=0.08,  
SPEC\_ID(1,1)='REAC\_FUEL',  
NU\_SPEC(1,1)=0.92,  
REFERENCE\_TEMPERATURE=300.0/

&MATL ID='char',

SPECIFIC\_HEAT=1.0,  
CONDUCTIVITY=0.1,  
DENSITY=71.0/

&MATL ID='FiberSiding',

SPECIFIC\_HEAT=0.84,  
CONDUCTIVITY=0.245,  
DENSITY=1770.0,  
EMISSIVITY=0.54/

&MATL ID='Redwood',

SPECIFIC\_HEAT=1.76,  
CONDUCTIVITY=0.26,  
DENSITY=510.0,  
EMISSIVITY=0.84/

&SURF ID='Roof',

BACKING='VOID',  
MATL\_ID(1,1)='Shingles',  
MATL\_MASS\_FRACTION(1,1)=1.0,  
THICKNESS(1)=0.2/

&SURF ID='brand',

MATL\_ID(1,1)='wood',  
MATL\_MASS\_FRACTION(1,1)=1.0,

```
THICKNESS(1)=4.0E-3,
GEOMETRY='CYLINDRICAL',
LENGTH=0.0135,
INNER_RADIUS=0.0,
EXTERNAL_FLUX=50.0/
&SURF ID='Siding',
BACKING='VOID',
MATL_ID(1,1)='FiberSiding',
MATL_MASS_FRACTION(1,1)=1.0,
THICKNESS(1)=0.2/
&SURF ID='Deck',
RGB=255,14,18,
MATL_ID(1,1)='Redwood',
MATL_MASS_FRACTION(1,1)=1.0,
THICKNESS(1)=0.2/

&INIT ID='Particle Cloud', PART_ID='rods', N_PARTICLES=67, DT_INSERT=0.01, MASS_PER_TIME=0.1,
XB=-20.0,12.0,-15.0,6.0,6.2,6.3/

&OBST ID='wall1', XB=-13.987911,-3.245556,1.148659,1.263195,0.0,3.1, SURF_ID='Siding'/
&OBST ID='wall2', XB=-13.987911,-3.245556,-9.451341,-9.336805,0.0,3.1, SURF_ID='Siding'/
&OBST ID='wall3', XB=-3.359903,-3.25,-9.451341,1.263195,0.0,3.1, SURF_ID='Siding'/
&OBST ID='wall4', XB=-13.989903,-13.875556,-9.451341,1.263195,0.0,3.1, SURF_ID='Siding'/
&OBST ID='AcDb3dSolid - C4', XB=-14.25,-14.125,-9.625,1.375,2.91525,3.2955, RGB=0,204,204,
SURF_ID='Roof'/
&OBST ID='AcDb3dSolid - C4', XB=-14.25,-3.0,-9.75,-9.625,2.91525,3.2955, RGB=0,204,204,
SURF_ID='Roof'/
&OBST ID='AcDb3dSolid - C4', XB=-14.25,-3.0,1.375,1.5,2.91525,3.2955, RGB=0,204,204,
SURF_ID='Roof'/
```



&OBST ID='AcDb3dSolid - C4', XB=-14.125,-13.875,-9.375,1.125,3.042,3.42225, RGB=0,204,204,  
SURF\_ID='Roof'/

&OBST ID='AcDb3dSolid - C4', XB=-14.125,-3.125,-9.625,-9.375,3.042,3.42225, RGB=0,204,204,  
SURF\_ID='Roof'/

&OBST ID='AcDb3dSolid - C4', XB=-14.125,-3.125,1.125,1.375,3.042,3.42225, RGB=0,204,204,  
SURF\_ID='Roof'/

&OBST ID='AcDb3dSolid - C4', XB=-13.875,-13.625,-9.125,0.875,3.16875,3.549, RGB=0,204,204,  
SURF\_ID='Roof'/

&OBST ID='AcDb3dSolid - C4', XB=-13.875,-3.375,-9.375,-9.125,3.16875,3.549, RGB=0,204,204,  
SURF\_ID='Roof'/

&OBST ID='AcDb3dSolid - C4', XB=-13.875,-3.375,0.875,1.125,3.16875,3.549, RGB=0,204,204,  
SURF\_ID='Roof'/

&OBST ID='AcDb3dSolid - C4', XB=-13.625,-13.375,-8.875,0.625,3.2955,3.67575, RGB=0,204,204,  
SURF\_ID='Roof'/

&OBST ID='AcDb3dSolid - C4', XB=-13.625,-3.625,-9.125,-8.875,3.2955,3.67575, RGB=0,204,204,  
SURF\_ID='Roof'/

&OBST ID='AcDb3dSolid - C4', XB=-13.625,-3.625,0.625,0.875,3.2955,3.67575, RGB=0,204,204,  
SURF\_ID='Roof'/

&OBST ID='AcDb3dSolid - C4', XB=-13.375,-13.125,-8.625,0.375,3.42225,3.8025, RGB=0,204,204,  
SURF\_ID='Roof'/

&OBST ID='AcDb3dSolid - C4', XB=-13.375,-3.875,-8.875,-8.625,3.42225,3.8025, RGB=0,204,204,  
SURF\_ID='Roof'/

&OBST ID='AcDb3dSolid - C4', XB=-13.375,-3.875,0.375,0.625,3.42225,3.8025, RGB=0,204,204,  
SURF\_ID='Roof'/

&OBST ID='AcDb3dSolid - C4', XB=-13.125,-12.875,-8.375,0.125,3.549,3.92925, RGB=0,204,204,  
SURF\_ID='Roof'/

&OBST ID='AcDb3dSolid - C4', XB=-13.125,-4.125,-8.625,-8.375,3.549,3.92925, RGB=0,204,204,  
SURF\_ID='Roof'/

&OBST ID='AcDb3dSolid - C4', XB=-13.125,-4.125,0.125,0.375,3.549,3.92925, RGB=0,204,204,  
SURF\_ID='Roof'/

&OBST ID='AcDb3dSolid - C4', XB=-12.875,-12.625,-8.125,-0.125,3.67575,4.056, RGB=0,204,204,  
SURF\_ID='Roof'/

&OBST ID='AcDb3dSolid - C4', XB=-12.875,-4.375,-8.375,-8.125,3.67575,4.056, RGB=0,204,204,  
SURF\_ID='Roof'/

&OBST ID='AcDb3dSolid - C4', XB=-12.875,-4.375,-0.125,0.125,3.67575,4.056, RGB=0,204,204,  
SURF\_ID='Roof'/

&OBST ID='AcDb3dSolid - C4', XB=-12.625,-12.375,-7.875,-0.375,3.8025,4.18275, RGB=0,204,204,  
SURF\_ID='Roof'/

&OBST ID='AcDb3dSolid - C4', XB=-12.625,-4.625,-0.25,-0.125,3.8025,4.056, RGB=0,204,204,  
SURF\_ID='Roof'/

&OBST ID='AcDb3dSolid - C4', XB=-12.625,-4.625,-8.125,-7.875,3.8025,4.18275, RGB=0,204,204,  
SURF\_ID='Roof'/

&OBST ID='AcDb3dSolid - C4', XB=-12.625,-4.625,-0.375,-0.25,3.8025,4.18275, RGB=0,204,204,  
SURF\_ID='Roof'/

&OBST ID='AcDb3dSolid - C4', XB=-12.375,-12.125,-7.625,-0.625,3.92925,4.3095, RGB=0,204,204,  
SURF\_ID='Roof'/

&OBST ID='AcDb3dSolid - C4', XB=-12.375,-5.0,-7.875,-7.625,3.92925,4.3095, RGB=0,204,204,  
SURF\_ID='Roof'/

&OBST ID='AcDb3dSolid - C4', XB=-12.375,-5.0,-0.625,-0.5,3.92925,4.3095, RGB=0,204,204,  
SURF\_ID='Roof'/

&OBST ID='AcDb3dSolid - C4', XB=-12.375,-4.875,-0.5,-0.375,3.92925,4.18275, RGB=0,204,204,  
SURF\_ID='Roof'/

&OBST ID='AcDb3dSolid - C4', XB=-12.125,-11.875,-7.375,-0.875,4.056,4.43625, RGB=0,204,204,  
SURF\_ID='Roof'/

&OBST ID='AcDb3dSolid - C4', XB=-12.125,-5.25,-7.625,-7.375,4.056,4.43625, RGB=0,204,204,  
SURF\_ID='Roof'/

&OBST ID='AcDb3dSolid - C4', XB=-12.125,-5.25,-0.875,-0.75,4.056,4.43625, RGB=0,204,204,  
SURF\_ID='Roof'/

&OBST ID='AcDb3dSolid - C4', XB=-12.125,-5.125,-0.75,-0.625,4.056,4.3095, RGB=0,204,204,  
SURF\_ID='Roof'/

&OBST ID='AcDb3dSolid - C4', XB=-11.875,-11.625,-7.125,-1.125,4.18275,4.563, RGB=0,204,204,  
SURF\_ID='Roof'/

&OBST ID='AcDb3dSolid - C4', XB=-11.875,-5.5,-7.375,-7.125,4.18275,4.563, RGB=0,204,204,  
SURF\_ID='Roof'/

&OBST ID='AcDb3dSolid - C4', XB=-11.875,-5.5,-1.125,-1.0,4.18275,4.563, RGB=0,204,204,  
SURF\_ID='Roof'/

&OBST ID='AcDb3dSolid - C4', XB=-11.875,-5.375,-1.0,-0.875,4.18275,4.43625, RGB=0,204,204,  
SURF\_ID='Roof'/

&OBST ID='AcDb3dSolid - C4', XB=-11.625,-11.5,-7.125,-1.25,4.3095,4.563, RGB=0,204,204,  
SURF\_ID='Roof'/

&OBST ID='AcDb3dSolid - C4', XB=-11.625,-5.625,-1.25,-1.125,4.3095,4.563, RGB=0,204,204,  
SURF\_ID='Roof'/

&OBST ID='AcDb3dSolid - C4', XB=-11.5,-11.375,-6.875,-1.375,4.3095,4.68975, RGB=0,204,204,  
SURF\_ID='Roof'/

&OBST ID='AcDb3dSolid - C4', XB=-11.5,-5.75,-7.125,-6.875,4.3095,4.68975, RGB=0,204,204,  
SURF\_ID='Roof'/

&OBST ID='AcDb3dSolid - C4', XB=-11.5,-5.75,-1.375,-1.25,4.3095,4.68975, RGB=0,204,204,  
SURF\_ID='Roof'/

&OBST ID='AcDb3dSolid - C4', XB=-11.375,-11.25,-6.75,-1.5,4.43625,4.68975, RGB=0,204,204,  
SURF\_ID='Roof'/

&OBST ID='AcDb3dSolid - C4', XB=-11.375,-5.875,-6.875,-6.75,4.43625,4.68975, RGB=0,204,204,  
SURF\_ID='Roof'/

&OBST ID='AcDb3dSolid - C4', XB=-11.375,-5.875,-1.5,-1.375,4.43625,4.68975, RGB=0,204,204,  
SURF\_ID='Roof'/

&OBST ID='AcDb3dSolid - C4', XB=-11.25,-11.125,-6.625,-1.625,4.43625,4.8165, RGB=0,204,204,  
SURF\_ID='Roof'/

&OBST ID='AcDb3dSolid - C4', XB=-11.25,-6.0,-6.75,-6.625,4.43625,4.8165, RGB=0,204,204,  
SURF\_ID='Roof'/

&OBST ID='AcDb3dSolid - C4', XB=-11.25,-6.0,-1.625,-1.5,4.43625,4.8165, RGB=0,204,204,  
SURF\_ID='Roof'/

&OBST ID='AcDb3dSolid - C4', XB=-11.125,-11.0,-6.5,-1.75,4.563,4.8165, RGB=0,204,204,  
SURF\_ID='Roof'/

&OBST ID='AcDb3dSolid - C4', XB=-11.125,-6.125,-6.625,-6.5,4.563,4.8165, RGB=0,204,204,  
SURF\_ID='Roof'/

&OBST ID='AcDb3dSolid - C4', XB=-11.125,-6.125,-1.75,-1.625,4.563,4.8165, RGB=0,204,204,  
SURF\_ID='Roof'/

&OBST ID='AcDb3dSolid - C4', XB=-11.0,-10.875,-6.375,-1.875,4.563,4.94325, RGB=0,204,204,  
SURF\_ID='Roof'/

&OBST ID='AcDb3dSolid - C4', XB=-11.0,-6.25,-6.5,-6.375,4.563,4.94325, RGB=0,204,204,  
SURF\_ID='Roof'/

&OBST ID='AcDb3dSolid - C4', XB=-11.0,-6.25,-1.875,-1.75,4.563,4.94325, RGB=0,204,204,  
SURF\_ID='Roof'/

&OBST ID='AcDb3dSolid - C4', XB=-10.875,-10.75,-6.25,-2.0,4.68975,4.94325, RGB=0,204,204,  
SURF\_ID='Roof'/

&OBST ID='AcDb3dSolid - C4', XB=-10.875,-6.375,-6.375,-6.25,4.68975,4.94325, RGB=0,204,204,  
SURF\_ID='Roof'/

&OBST ID='AcDb3dSolid - C4', XB=-10.875,-6.375,-2.0,-1.875,4.68975,4.94325, RGB=0,204,204,  
SURF\_ID='Roof'/

&OBST ID='AcDb3dSolid - C4', XB=-10.75,-10.625,-6.125,-2.125,4.68975,5.07, RGB=0,204,204,  
SURF\_ID='Roof'/

&OBST ID='AcDb3dSolid - C4', XB=-10.75,-6.5,-6.25,-6.125,4.68975,5.07, RGB=0,204,204,  
SURF\_ID='Roof'/

&OBST ID='AcDb3dSolid - C4', XB=-10.75,-6.5,-2.125,-2.0,4.68975,5.07, RGB=0,204,204, SURF\_ID='Roof'/

&OBST ID='AcDb3dSolid - C4', XB=-10.625,-10.5,-6.0,-2.25,4.8165,5.07, RGB=0,204,204, SURF\_ID='Roof'/

&OBST ID='AcDb3dSolid - C4', XB=-10.625,-6.625,-6.125,-6.0,4.8165,5.07, RGB=0,204,204,  
SURF\_ID='Roof'/

&OBST ID='AcDb3dSolid - C4', XB=-10.625,-6.625,-2.25,-2.125,4.8165,5.07, RGB=0,204,204,  
SURF\_ID='Roof'/

&OBST ID='AcDb3dSolid - C4', XB=-10.5,-10.375,-5.875,-2.375,4.8165,5.19675, RGB=0,204,204,  
SURF\_ID='Roof'/

&OBST ID='AcDb3dSolid - C4', XB=-10.5,-6.75,-6.0,-5.875,4.8165,5.19675, RGB=0,204,204,  
SURF\_ID='Roof'/

&OBST ID='AcDb3dSolid - C4', XB=-10.5,-6.75,-2.375,-2.25,4.8165,5.19675, RGB=0,204,204,  
SURF\_ID='Roof'/

&OBST ID='AcDb3dSolid - C4', XB=-10.375,-10.25,-5.75,-2.5,4.94325,5.19675, RGB=0,204,204,  
SURF\_ID='Roof'/

&OBST ID='AcDb3dSolid - C4', XB=-10.375,-6.875,-5.875,-5.75,4.94325,5.19675, RGB=0,204,204,  
SURF\_ID='Roof'/

&OBST ID='AcDb3dSolid - C4', XB=-10.375,-6.875,-2.5,-2.375,4.94325,5.19675, RGB=0,204,204,  
SURF\_ID='Roof'/

&OBST ID='AcDb3dSolid - C4', XB=-10.25,-10.125,-5.625,-2.625,4.94325,5.3235, RGB=0,204,204,  
SURF\_ID='Roof'/

&OBST ID='AcDb3dSolid - C4', XB=-10.25,-7.0,-5.75,-5.625,4.94325,5.3235, RGB=0,204,204,  
SURF\_ID='Roof'/

&OBST ID='AcDb3dSolid - C4', XB=-10.25,-7.0,-2.625,-2.5,4.94325,5.3235, RGB=0,204,204,  
SURF\_ID='Roof'/

&OBST ID='AcDb3dSolid - C4', XB=-10.125,-10.0,-5.5,-2.75,5.07,5.3235, RGB=0,204,204, SURF\_ID='Roof'/

&OBST ID='AcDb3dSolid - C4', XB=-10.125,-7.125,-5.625,-5.5,5.07,5.3235, RGB=0,204,204,  
SURF\_ID='Roof'/

&OBST ID='AcDb3dSolid - C4', XB=-10.125,-7.125,-2.75,-2.625,5.07,5.3235, RGB=0,204,204,  
SURF\_ID='Roof'/

&OBST ID='AcDb3dSolid - C4', XB=-10.0,-9.875,-5.375,-2.875,5.07,5.45025, RGB=0,204,204,  
SURF\_ID='Roof'/

&OBST ID='AcDb3dSolid - C4', XB=-10.0,-7.25,-5.5,-5.375,5.07,5.45025, RGB=0,204,204, SURF\_ID='Roof'/

&OBST ID='AcDb3dSolid - C4', XB=-10.0,-7.25,-2.875,-2.75,5.07,5.45025, RGB=0,204,204,  
SURF\_ID='Roof'/

&OBST ID='AcDb3dSolid - C4', XB=-9.875,-9.75,-5.25,-3.0,5.19675,5.45025, RGB=0,204,204,  
SURF\_ID='Roof'/

&OBST ID='AcDb3dSolid - C4', XB=-9.875,-7.375,-5.375,-5.25,5.19675,5.45025, RGB=0,204,204,  
SURF\_ID='Roof'/

&OBST ID='AcDb3dSolid - C4', XB=-9.875,-7.375,-3.0,-2.875,5.19675,5.45025, RGB=0,204,204,  
SURF\_ID='Roof'/

&OBST ID='AcDb3dSolid - C4', XB=-9.75,-9.625,-5.125,-3.125,5.19675,5.577, RGB=0,204,204,  
SURF\_ID='Roof'/

&OBST ID='AcDb3dSolid - C4', XB=-9.75,-7.5,-5.25,-5.125,5.19675,5.577, RGB=0,204,204,  
SURF\_ID='Roof'/

&OBST ID='AcDb3dSolid - C4', XB=-9.75,-7.5,-3.125,-3.0,5.19675,5.577, RGB=0,204,204, SURF\_ID='Roof'/

&OBST ID='AcDb3dSolid - C4', XB=-9.625,-9.5,-5.0,-3.25,5.3235,5.577, RGB=0,204,204, SURF\_ID='Roof'/

&OBST ID='AcDb3dSolid - C4', XB=-9.625,-7.625,-5.125,-5.0,5.3235,5.577, RGB=0,204,204,  
SURF\_ID='Roof'/

&OBST ID='AcDb3dSolid - C4', XB=-9.625,-7.625,-3.25,-3.125,5.3235,5.577, RGB=0,204,204,  
SURF\_ID='Roof'/

&OBST ID='AcDb3dSolid - C4', XB=-9.5,-9.375,-4.875,-3.375,5.3235,5.70375, RGB=0,204,204,  
SURF\_ID='Roof'/

&OBST ID='AcDb3dSolid - C4', XB=-9.5,-7.75,-5.0,-4.875,5.3235,5.70375, RGB=0,204,204,  
SURF\_ID='Roof'/

&OBST ID='AcDb3dSolid - C4', XB=-9.5,-7.75,-3.375,-3.25,5.3235,5.70375, RGB=0,204,204,  
SURF\_ID='Roof'/

&OBST ID='AcDb3dSolid - C4', XB=-9.375,-9.25,-4.75,-3.5,5.45025,5.70375, RGB=0,204,204,  
SURF\_ID='Roof'/

&OBST ID='AcDb3dSolid - C4', XB=-9.375,-7.875,-4.875,-4.75,5.45025,5.70375, RGB=0,204,204,  
SURF\_ID='Roof'/

&OBST ID='AcDb3dSolid - C4', XB=-9.375,-7.875,-3.5,-3.375,5.45025,5.70375, RGB=0,204,204,  
SURF\_ID='Roof'/

&OBST ID='AcDb3dSolid - C4', XB=-9.25,-9.125,-4.625,-3.625,5.45025,5.8305, RGB=0,204,204,  
SURF\_ID='Roof'/

&OBST ID='AcDb3dSolid - C4', XB=-9.25,-8.0,-4.75,-4.625,5.45025,5.8305, RGB=0,204,204,  
SURF\_ID='Roof'/

&OBST ID='AcDb3dSolid - C4', XB=-9.25,-8.0,-3.625,-3.5,5.45025,5.8305, RGB=0,204,204,  
SURF\_ID='Roof'/

&OBST ID='AcDb3dSolid - C4', XB=-9.125,-9.0,-4.5,-3.75,5.577,5.8305, RGB=0,204,204, SURF\_ID='Roof'/

&OBST ID='AcDb3dSolid - C4', XB=-9.125,-8.125,-4.625,-4.5,5.577,5.8305, RGB=0,204,204,  
SURF\_ID='Roof'/

&OBST ID='AcDb3dSolid - C4', XB=-9.125,-8.125,-3.75,-3.625,5.577,5.8305, RGB=0,204,204,  
SURF\_ID='Roof'/

&OBST ID='AcDb3dSolid - C4', XB=-9.0,-8.875,-4.375,-3.875,5.577,5.95725, RGB=0,204,204,  
SURF\_ID='Roof'/

&OBST ID='AcDb3dSolid - C4', XB=-9.0,-8.25,-4.5,-4.375,5.577,5.95725, RGB=0,204,204, SURF\_ID='Roof'/

&OBST ID='AcDb3dSolid - C4', XB=-9.0,-8.25,-3.875,-3.75,5.577,5.95725, RGB=0,204,204,  
SURF\_ID='Roof'/

&OBST ID='AcDb3dSolid - C4', XB=-8.875,-8.75,-4.25,-4.0,5.70375,5.95725, RGB=0,204,204,  
SURF\_ID='Roof'/

&OBST ID='AcDb3dSolid - C4', XB=-8.875,-8.375,-4.375,-4.25,5.70375,5.95725, RGB=0,204,204,  
SURF\_ID='Roof'/

&OBST ID='AcDb3dSolid - C4', XB=-8.875,-8.375,-4.0,-3.875,5.70375,5.95725, RGB=0,204,204,  
SURF\_ID='Roof'/

&OBST ID='AcDb3dSolid - C4', XB=-8.75,-8.5,-4.25,-4.0,5.70375,6.084, RGB=0,204,204, SURF\_ID='Roof'/

&OBST ID='AcDb3dSolid - C4', XB=-8.5,-8.375,-4.25,-4.0,5.70375,5.95725, RGB=0,204,204,  
SURF\_ID='Roof'/

&OBST ID='AcDb3dSolid - C4', XB=-8.375,-8.25,-4.375,-3.875,5.577,5.95725, RGB=0,204,204,  
SURF\_ID='Roof'/

&OBST ID='AcDb3dSolid - C4', XB=-8.25,-8.125,-4.5,-3.75,5.577,5.8305, RGB=0,204,204, SURF\_ID='Roof'/

&OBST ID='AcDb3dSolid - C4', XB=-8.125,-8.0,-4.625,-3.625,5.45025,5.8305, RGB=0,204,204,  
SURF\_ID='Roof'/

&OBST ID='AcDb3dSolid - C4', XB=-8.0,-7.875,-4.75,-3.5,5.45025,5.70375, RGB=0,204,204,  
SURF\_ID='Roof'/

&OBST ID='AcDb3dSolid - C4', XB=-7.875,-7.75,-4.875,-3.375,5.3235,5.70375, RGB=0,204,204,  
SURF\_ID='Roof'/

&OBST ID='AcDb3dSolid - C4', XB=-7.75,-7.625,-5.0,-3.25,5.3235,5.577, RGB=0,204,204, SURF\_ID='Roof'/

&OBST ID='AcDb3dSolid - C4', XB=-7.625,-7.5,-5.125,-3.125,5.19675,5.577, RGB=0,204,204,  
SURF\_ID='Roof'/

&OBST ID='AcDb3dSolid - C4', XB=-7.5,-7.375,-5.25,-3.0,5.19675,5.45025, RGB=0,204,204,  
SURF\_ID='Roof'/

&OBST ID='AcDb3dSolid - C4', XB=-7.375,-7.25,-5.375,-2.875,5.07,5.45025, RGB=0,204,204,  
SURF\_ID='Roof'/

&OBST ID='AcDb3dSolid - C4', XB=-7.25,-7.125,-5.5,-2.75,5.07,5.3235, RGB=0,204,204, SURF\_ID='Roof'/

&OBST ID='AcDb3dSolid - C4', XB=-7.125,-7.0,-5.625,-2.625,4.94325,5.3235, RGB=0,204,204,  
SURF\_ID='Roof'/

&OBST ID='AcDb3dSolid - C4', XB=-7.0,-6.875,-5.75,-2.5,4.94325,5.19675, RGB=0,204,204,  
SURF\_ID='Roof'/

&OBST ID='AcDb3dSolid - C4', XB=-6.875,-6.75,-5.875,-2.375,4.8165,5.19675, RGB=0,204,204,  
SURF\_ID='Roof'/

&OBST ID='AcDb3dSolid - C4', XB=-6.75,-6.625,-6.0,-2.25,4.8165,5.07, RGB=0,204,204, SURF\_ID='Roof'/

&OBST ID='AcDb3dSolid - C4', XB=-6.625,-6.5,-6.125,-2.125,4.68975,5.07, RGB=0,204,204,  
SURF\_ID='Roof'/

&OBST ID='AcDb3dSolid - C4', XB=-6.5,-6.375,-6.25,-2.0,4.68975,4.94325, RGB=0,204,204,  
SURF\_ID='Roof'/

&OBST ID='AcDb3dSolid - C4', XB=-6.375,-6.25,-6.375,-1.875,4.563,4.94325, RGB=0,204,204,  
SURF\_ID='Roof'/

&OBST ID='AcDb3dSolid - C4', XB=-6.25,-6.125,-6.5,-1.75,4.563,4.8165, RGB=0,204,204, SURF\_ID='Roof'/

&OBST ID='AcDb3dSolid - C4', XB=-6.125,-6.0,-6.625,-1.625,4.43625,4.8165, RGB=0,204,204,  
SURF\_ID='Roof'/

&OBST ID='AcDb3dSolid - C4', XB=-6.0,-5.875,-6.75,-1.5,4.43625,4.68975, RGB=0,204,204,  
SURF\_ID='Roof'/

&OBST ID='AcDb3dSolid - C4', XB=-5.875,-5.75,-6.875,-1.375,4.3095,4.68975, RGB=0,204,204,  
SURF\_ID='Roof'/

&OBST ID='AcDb3dSolid - C4', XB=-5.75,-5.625,-7.125,-1.25,4.3095,4.563, RGB=0,204,204,  
SURF\_ID='Roof'/

&OBST ID='AcDb3dSolid - C4', XB=-5.625,-5.5,-7.125,-1.125,4.18275,4.563, RGB=0,204,204,  
SURF\_ID='Roof'/

&OBST ID='AcDb3dSolid - C4', XB=-5.5,-5.375,-7.375,-1.0,4.18275,4.43625, RGB=0,204,204,  
SURF\_ID='Roof'/

&OBST ID='AcDb3dSolid - C4', XB=-5.375,-5.25,-7.375,-0.875,4.056,4.43625, RGB=0,204,204,  
SURF\_ID='Roof'/

&OBST ID='AcDb3dSolid - C4', XB=-5.25,-5.125,-7.625,-0.75,4.056,4.3095, RGB=0,204,204,  
SURF\_ID='Roof'/

&OBST ID='AcDb3dSolid - C4', XB=-5.125,-5.0,-7.625,-0.625,3.92925,4.3095, RGB=0,204,204,  
SURF\_ID='Roof'/

&OBST ID='AcDb3dSolid - C4', XB=-5.0,-4.875,-7.875,-0.5,3.92925,4.18275, RGB=0,204,204,  
SURF\_ID='Roof'/

&OBST ID='AcDb3dSolid - C4', XB=-4.875,-4.625,-7.875,-0.375,3.8025,4.18275, RGB=0,204,204,  
SURF\_ID='Roof'/

&OBST ID='AcDb3dSolid - C4', XB=-4.625,-4.375,-8.125,-0.125,3.67575,4.056, RGB=0,204,204,  
SURF\_ID='Roof'/

&OBST ID='AcDb3dSolid - C4', XB=-4.375,-4.125,-8.375,0.125,3.549,3.92925, RGB=0,204,204,  
SURF\_ID='Roof'/

&OBST ID='AcDb3dSolid - C4', XB=-4.125,-3.875,-8.625,0.375,3.42225,3.8025, RGB=0,204,204,  
SURF\_ID='Roof'/

&OBST ID='AcDb3dSolid - C4', XB=-3.875,-3.625,-8.875,0.625,3.2955,3.67575, RGB=0,204,204,  
SURF\_ID='Roof'/

&OBST ID='AcDb3dSolid - C4', XB=-3.625,-3.375,-9.125,0.875,3.16875,3.549, RGB=0,204,204,  
SURF\_ID='Roof'/

&OBST ID='AcDb3dSolid - C4', XB=-3.375,-3.125,-9.375,1.125,3.042,3.42225, RGB=0,204,204,  
SURF\_ID='Roof'/

&OBST ID='AcDb3dSolid - C4', XB=-3.125,-3.0,-9.625,1.375,2.91525,3.2955, RGB=0,204,204,  
SURF\_ID='Roof'/

&OBST ID='Deck', XB=-3.375,1.375,-9.5,-5.0,0.0,0.2535, THICKEN=.TRUE., SURF\_ID='Deck'/

&OBST ID='Deck', XB=-3.25,1.375,-5.0,1.25,0.0,0.2535, THICKEN=.TRUE., SURF\_ID='Deck'/

&VENT ID='Mesh Vent: Mesh01 [XMIN]', SURF\_ID='OPEN', XB=-20.0,-20.0,-15.0,6.0,0.0,6.3375,  
COLOR='INVISIBLE'/



&VENT ID='Mesh Vent: Mesh01 [XMAX]', SURF\_ID='OPEN', XB=12.0,12.0,-15.0,6.0,0.0,6.3375,  
COLOR='INVISIBLE'/

&VENT ID='Mesh Vent: Mesh01 [YMIN]', SURF\_ID='OPEN', XB=-20.0,12.0,-15.0,-15.0,0.0,6.3375,  
COLOR='INVISIBLE'/

&VENT ID='Mesh Vent: Mesh01 [YMAX]', SURF\_ID='OPEN', XB=-20.0,12.0,6.0,6.0,0.0,6.3375,  
COLOR='INVISIBLE'/

&VENT ID='Mesh Vent: Mesh01 [ZMAX]', SURF\_ID='OPEN', XB=-20.0,12.0,-15.0,6.0,6.3375,6.3375,  
IOR=3, COLOR='INVISIBLE'/

&SLCF QUANTITY='TEMPERATURE', VECTOR=.TRUE., PBX=-4.133165/

&SLCF QUANTITY='VELOCITY', VECTOR=.TRUE., PBX=-4.133165/

&SLCF QUANTITY='HRRPUV', PBX=-4.133165/

&SLCF QUANTITY='MIXTURE FRACTION', PBX=-4.133165/

&DEVC ID='Mass\_VOLUME INTEGRAL', QUANTITY='MPUV', PART\_ID='rods', STATISTICS='VOLUME  
INTEGRAL', XB=-20.0,6.0,-10.0,2.0,0.0,6.3375/

&DEVC ID='Mass01\_VOLUME INTEGRAL', QUANTITY='MPUV', PART\_ID='rods', STATISTICS='VOLUME  
INTEGRAL', XB=-3.25,1.5,-9.75,1.5,0.0,0.507/

&TAIL /

## Appendix C: Component Data Sheets



## TECHNICAL DATA

## MODEL E SPRAY NOZZLES VK810 - VK817

The Viking Corporation, 210 N Industrial Park Drive, Hastings MI 49058

Telephone: 269-945-9501 Technical Services: 877-384-5464 Fax: 269-818-1680 Email: techsvcs@vikingcorp.com

### 1. DESCRIPTION

Viking Model E, 3D Spray Nozzles are open type spray nozzles designed for directional spray applications in fixed fire protection systems. They have an open design only (non-automatic) with an external deflector that discharges a solid uniform cone spray of low- to medium- velocity water droplets. Model E Spray Nozzles are available in multiple orifice sizes and spray angles to meet design application requirements and they include a 1/2" NPT (DN15) external pipe thread. The base materials are brass, while electroless nickel plating may be applied to the complete assembly for applications requiring corrosion resistance.

The spray angle is the included angle of discharge for each nozzle, and is also marked on the deflector. Figures 1a and 1b illustrate the distribution width at various heights based on testing in the pendent position at 10, 20, and 60 PSI (0.7 bar, 1.4 bar, and 4.1 bar) discharge pressures. Note that the Model E Spray Nozzles are rated for a maximum discharge pressure of 175 PSI (12 bar). At pressures above 60 PSI (4.1 bar), the spray pattern begins to decrease in width due to pull-in of the spray pattern. For exposure protection, see Figures 6a, 6b, and 7 for fixed position angle, distance for included angle spray pattern perpendicular to surface of object at the fixed angle of installation.

For nozzles having nominal U.S. K-Factors of 1.2, 1.8, and 2.3, a bushing is used, flush at the inlet location, to eliminate sharp corner cavity and to prevent debris from collecting. (Nozzles with K-Factors of 3.2, 4.1, 5.6, and 7.2 are machined orifices.) Optional blow-off plugs are available for protection from dust and insect infestation and other accumulation of debris.



### 2. LISTINGS AND APPROVALS



**cULus Listed:** Category VGYZ



**FM Approved:** Fixed Extinguishing Systems

**NYC Approved:** MEA 89-92-E, Volume 29

Refer to the Approval Chart on page 32c and Design Criteria on page 32e for cULus Listing and FM Approval requirements that must be followed.

### 3. TECHNICAL DATA

#### Specifications:

Minimum Operating Pressure: 10 psi (0.7 bar)

Maximum Working Pressure: 175 psi (12 bar)

Thread size: 1/2" (15 mm) NPT

Nominal K-Factor: 7.2 U.S. (103.7 metric\*)

5.6 U.S. (80.6 metric)

4.1 U.S. (59.0 metric)

3.2 U.S. (46.1 metric)

2.3 U.S. (33.1 metric)

1.8 U.S. (25.9 metric)

1.2 U.S. (17.3 metric)

Orifice sizes are indicated by the K-Factor, which is marked on the deflector. Refer to the Nominal Discharge Curves on page 32f for each nozzle at various operating residual pressures.

\* Metric K-factor measurement shown is when pressure is measured in Bar. When pressure is measured in kPa, divide the metric K-factor shown by 10.0.

Overall Length: 2-7/16" (61 mm)

#### Material Standards:

Body Casting: Brass UNS-C84400

Splitter: Brass UNS-C36000

Bushing: (for nozzles with 1.2, 1.8, and 2.3 K-Factors): Brass UNS-C36000

Deflector: Phosphor Bronze UNS-C51000

Screw: Brass UNS-C65100

**Ordering Information:** (Also refer to the current Viking price list.)

Viking Technical Data may be found on  
The Viking Corporation's Web site at  
<http://www.vikinggroupinc.com>.  
The Web site may include a more recent  
edition of this Technical Data Page.



## TECHNICAL DATA

## MODEL E SPRAY NOZZLES VK810 - VK817

The Viking Corporation, 210 N Industrial Park Drive, Hastings MI 49058

Telephone: 269-945-9501 Technical Services: 877-384-5464 Fax: 269-818-1680 Email: techsvcs@vikingcorp.com

Order Model E Spray Nozzles by first selecting the appropriate base part number for the K-Factor and spray angle desired. Then add the appropriate suffix for the desired finish and the suffix "Z" for open nozzles to the spray nozzle base part number.

Finish Suffix: Brass = A, Electroless Nickel Plated = J

Temperature Suffix: OPEN = Z

For example, spray nozzle VK810 with a K-Factor of 7.2 (103.7 metric) and a Brass finish = Part No. 12867AZ

**Accessories:** (Also refer to the "Sprinkler Accessories" section of the Viking data book.)

**Sprinkler Wrench:** Part No. 10896W/B (available since 2000).

**Blow-Off Plugs (Optional):** Refer to technical data page 33y. Blow-off plugs are used to prevent the depositing of foreign materials in the waterway, which could interfere with the discharge of the spray nozzles. The plugs are designed to blow off when the system piping is pressurized. **Note:** The blow-off plugs are NOT cULus Listed or FM Approved.

#### 4. INSTALLATION

**WARNING:** Viking Model E Spray Nozzles are manufactured and tested to meet the rigid requirements of the approving agency. The nozzles are designed to be installed in accordance with recognized installation standards. Deviation from the standards or any alteration to the nozzle after it leaves the factory including, but not limited to: painting, plating, coating, or modification, may render the unit inoperative and will automatically nullify the approval and any guarantee made by The Viking Corporation.

The Approval Chart on page 32c shows listings and approvals of Model E Spray Nozzles for use on water spray systems and water based deluge systems. The chart shows listings and approvals available at the time of printing. Other approvals are in process. Check with the manufacturer for any additional approvals.

- A. **Spray nozzles are to be installed in accordance with the latest edition of Viking technical data, the latest published standards of NFPA, FM Global, LPCB, APSAD, VdS or other similar organizations, and also with the provisions of governmental codes, ordinances, and standards whenever applicable. The use of Model E Spray Nozzles may be limited due to occupancy and hazard. Refer to the Authority Having Jurisdiction prior to installation.**
- B. Handle Model E Spray Nozzles with care. They must be stored in a cool, dry place in their original shipping container. Never install a spray nozzle that has been dropped or damaged.
- C. Corrosion-resistant spray nozzles must be installed when subject to corrosive atmospheres.
- D. Spray nozzles must be installed after the piping is in place to prevent mechanical damage.
- E. Before installing, be sure to have the appropriate model and style, with the correct K-Factor and spray angle. Spray nozzle deflectors are identified with the VK model number, nominal K-Factor, and spray angle.
  1. Apply a small amount of pipe-joint compound or tape to the external threads of the spray nozzle only, taking care not to allow a build-up of compound inside the inlet.
  2. Install the nozzle on the fixed piping, using the special sprinkler/spray nozzle wrench only. Take care not to over-tighten or damage the spray nozzle. DO NOT use the deflector to start or thread the unit into a fitting.
- F. Spray nozzles must be protected from mechanical damage. Where open spray nozzles are used, care must be taken to prevent foreign materials from entering the orifice. Foreign materials may accumulate and restrict or plug the waterway and may prevent proper operation of the spray nozzle.

#### 5. OPERATION

Model E, 3D Spray Nozzles are designed to apply cooling water to exposed vertical, horizontal, curved, and irregular shaped surfaces to allow cooling of objects externally when exposed to an adjacent fire. Cooling is done to prevent objects from absorbing heat that could cause structural damage and possible spread of fire to the protected object. In some applications, Model E Spray Nozzles may be applied to control or extinguish fire of the protected area (depending on water design application density).

#### 6. INSPECTIONS, TESTS AND MAINTENANCE

**NOTICE:** The owner is responsible for maintaining the fire protection system and devices in proper operating condition. For minimum maintenance and inspection requirements, refer to the NFPA standard (e.g., NFPA 25) that describes care and maintenance of sprinkler systems. In addition, the AHJ may have additional maintenance, testing, and inspection requirements that must be followed.

- A. Spray nozzles must be inspected on a regular basis for corrosion, mechanical damage, obstructions, paint, etc. Where open spray nozzles are installed, verify that foreign materials (such as dust, dirt, etc.) DO NOT restrict or plug the waterspray. The frequency of inspections may vary due to corrosive atmospheres, water supplies, and activity around the device. It is also recommended that outdoor installations of Model E Spray Nozzles with blow-off plugs be periodically inspected, during freezing weather conditions, for the presence of ice buildup from trapped condensate which could effect the proper release of the plugs.
- B. Spray nozzles that have been painted or mechanically damaged must be replaced immediately. Nozzles showing signs of corrosion shall be tested and/or replaced immediately as required. When replacing spray nozzles, use only new Model E Spray Nozzles.

**TECHNICAL DATA****MODEL E SPRAY NOZZLES  
VK810 - VK817**

**The Viking Corporation, 210 N Industrial Park Drive, Hastings MI 49058**

**Telephone: 269-945-9501 Technical Services: 877-384-5464 Fax: 269-818-1680 Email: techsvcs@vikingcorp.com**

1. Using the appropriate wrench, remove the old spray nozzle and install the new unit. Care must be taken to ensure that the replacement spray nozzle has the proper model, style, and K-Factor. Model E Spray Nozzle deflectors are identified with the VK model number, nominal U.S. K-Factor, and spray angle. A cabinet should be provided and stocked with a wrench and extra spray nozzles of each variety used for replacement purposes.
- C. The spray nozzle discharge pattern is critical for proper fire protection. Therefore, nothing should be hung from, attached to, or otherwise obstruct the discharge pattern. All obstructions must be immediately removed or, if necessary, additional nozzles installed.
- D. Fire protection systems that have been subjected to a fire must be returned to service as soon as possible. The entire system must be inspected for damage and repaired or replaced as necessary. Spray nozzles that have been exposed to corrosive products of combustion or high ambient temperatures, should be replaced. Refer to the AHJ for minimum replacement requirements.

**7. AVAILABILITY**

Viking Model E Spray Nozzles are available through a network of domestic and international distributors. See The Viking Corporation web site for the closest distributor or contact The Viking Corporation.

**8. GUARANTEE**

For details of warranty, refer to Viking's current list price schedule or contact Viking directly.



## TECHNICAL DATA

## MODEL E SPRAY NOZZLES VK810 - VK817

The Viking Corporation, 210 N Industrial Park Drive, Hastings MI 49058

Telephone: 269-945-9501 Technical Services: 877-384-5464 Fax: 269-818-1680 Email: techsvcs@vikingcorp.com

### Approval Chart

Model E Spray Nozzles  
Maximum 175 PSI (12 bar) WWP

(Refer also to Design Criteria on page 32e.)

Base Part Number <sup>1</sup>	SIN <sup>2</sup>	Nominal K-Factor		Angle	Listings and Approvals <sup>4</sup>			Base Part Number <sup>1</sup>	SIN <sup>2</sup>	Nominal K-Factor		Angle	Listings and Approvals <sup>4</sup>		
		U.S.	metric <sup>3</sup>		cULus <sup>5</sup>	NYC <sup>6</sup>	FM			U.S.	metric <sup>3</sup>		cULus <sup>5</sup>	NYC <sup>6</sup>	FM
12867	VK810	7.2	103.7	65°	Yes	Yes	Yes	12895	VK814	7.2	103.7	125°	Yes	Yes	Yes
12868	VK810	5.6	80.6	65°	Yes	Yes	Yes	12896	VK814	5.6	80.6	125°	Yes	Yes	Yes
12869	VK810	4.1	59.0	65°	Yes	Yes	Yes	12897	VK814	4.1	59.0	125°	Yes	Yes	Yes
12870	VK810	3.2	46.1	65°	Yes	Yes	Yes <sup>7</sup>	12898	VK814	3.2	46.1	125°	Yes	Yes	Yes <sup>7</sup>
12871	VK810	2.3	33.1	65°	Yes	Yes	Yes <sup>7</sup>	12899	VK814	2.3	33.1	125°	Yes	Yes	Yes <sup>7</sup>
12872	VK810	1.8	25.9	65°	Yes	Yes	Yes <sup>7</sup>	12900	VK814	1.8	25.9	125°	Yes	Yes	Yes <sup>7</sup>
12873	VK810	1.2	17.3	65°	Yes	Yes	Yes <sup>7</sup>	12901	VK814	1.2	17.3	125°	Yes	Yes	Yes <sup>7</sup>
12874	VK811	7.2	103.7	80°	Yes	Yes	Yes	12902	VK815	7.2	103.7	140°	Yes	Yes	Yes
12875	VK811	5.6	80.6	80°	Yes	Yes	Yes	12903	VK815	5.6	80.6	140°	Yes	Yes	Yes
12876	VK811	4.1	59.0	80°	Yes	Yes	Yes	12904	VK815	4.1	59.0	140°	Yes	Yes	Yes
12877	VK811	3.2	46.1	80°	Yes	Yes	Yes <sup>7</sup>	12905	VK815	3.2	46.1	140°	Yes	Yes	Yes <sup>7</sup>
12878	VK811	2.3	33.1	80°	Yes	Yes	Yes <sup>7</sup>	12906	VK815	2.3	33.1	140°	Yes	Yes	Yes <sup>7</sup>
12879	VK811	1.8	25.9	80°	Yes	Yes	Yes <sup>7</sup>	12907	VK815	1.8	25.9	140°	Yes	Yes	Yes <sup>7</sup>
12880	VK811	1.2	17.3	80°	Yes	Yes	Yes <sup>7</sup>	12908	VK815	1.2	17.3	140°	Yes	Yes	Yes <sup>7</sup>
12881	VK812	7.2	103.7	95°	Yes	Yes	Yes	12909	VK816	7.2	103.7	160°	Yes	Yes	Yes
12882	VK812	5.6	80.6	95°	Yes	Yes	Yes	12910	VK816	5.6	80.6	160°	Yes	Yes	Yes
12883	VK812	4.1	59.0	95°	Yes	Yes	Yes	12911	VK816	4.1	59.0	160°	Yes	Yes	Yes
12884	VK812	3.2	46.1	95°	Yes	Yes	Yes <sup>7</sup>	12912	VK816	3.2	46.1	160°	Yes	Yes	Yes <sup>7</sup>
12885	VK812	2.3	33.1	95°	Yes	Yes	Yes <sup>7</sup>	12913	VK816	2.3	33.1	160°	Yes	Yes	Yes <sup>7</sup>
12886	VK812	1.8	25.9	95°	Yes	Yes	Yes <sup>7</sup>	12914	VK816	1.8	25.9	160°	Yes	Yes	Yes <sup>7</sup>
12887	VK812	1.2	17.3	95°	Yes	Yes	Yes <sup>7</sup>	12915	VK816	1.2	17.3	160°	Yes	Yes	Yes <sup>7</sup>
12888	VK813	7.2	103.7	110°	Yes	Yes	Yes	12916	VK817	7.2	103.7	180°	Yes	Yes	Yes
12889	VK813	5.6	80.6	110°	Yes	Yes	Yes	12917	VK817	5.6	80.6	180°	Yes	Yes	Yes
12890	VK813	4.1	59.0	110°	Yes	Yes	Yes	12918	VK817	4.1	59.0	180°	Yes	Yes	Yes
12891	VK813	3.2	46.1	110°	Yes	Yes	Yes <sup>7</sup>	12919	VK817	3.2	46.1	180°	Yes	Yes	Yes <sup>7</sup>
12892	VK813	2.3	33.1	110°	Yes	Yes	Yes <sup>7</sup>	12920	VK817	2.3	33.1	180°	Yes	Yes	Yes <sup>7</sup>
12893	VK813	1.8	25.9	110°	Yes	Yes	Yes <sup>7</sup>	12921	VK817	1.8	25.9	180°	Yes	Yes	Yes <sup>7</sup>
12894	VK813	1.2	17.3	110°	Yes	Yes	Yes <sup>7</sup>	12922	VK817	1.2	17.3	180°	Yes	Yes	Yes <sup>7</sup>

Available Finishes: Brass or Electroless Nickel Plated<sup>8</sup>

#### Footnotes

<sup>1</sup> Base part number is shown. For complete part number, refer to Viking's current price schedule.

<sup>2</sup> The spray nozzle deflector is identified with the VK model number, K-Factor, and spray angle.

<sup>3</sup> Metric K-factor shown is for use when pressure is measured in bar. When pressure is measured in kPa, divide the metric K-factor shown by 10.0.

<sup>4</sup> This table shows the listings and approvals available at the time of printing. Check with the manufacturer for any additional approvals.

<sup>5</sup> Listed by Underwriters Laboratories Inc. for use in the U.S. and Canada.

<sup>6</sup> Accepted for use, City of New York Department of Buildings, MEA Number 89-92-E, Vol. 29.

<sup>7</sup> Orifice diameter is less than 3/8" (9.4 mm) for Model E Nozzles with K-Factors of 3.2, 2.3, 1.8, and 1.2. A pipeline strainer with a 1/8" (3.2 mm) or less perforation is required for FM Approval.

<sup>8</sup> For corrosion resistance.



## TECHNICAL DATA

## MODEL E SPRAY NOZZLES VK810 - VK817

The Viking Corporation, 210 N Industrial Park Drive, Hastings MI 49058

Telephone: 269-945-9501 Technical Services: 877-384-5464 Fax: 269-818-1680 Email: techsvcs@vikingcorp.com

### DESIGN CRITERIA

(Also refer to the Approval Chart on page 32c.)

#### Nozzle Placement

When the Authority Having Jurisdiction requires direct impingement of water spray of the complete protected surface, the nozzles should be spaced and directed so their spray pattern will completely cover the surface plane of the protected object or area. Use the minimum required average density based on the included angle and the K-Factor based on the residual pressure at the inlet of the nozzles. Figures 1a and 1b indicate the coverage for each nozzle's included spray angle at various heights. Recommendation: Limit the maximum spacing of nozzles to 12 ft. (3.6 m) or less for indoor applications and 10 ft. (3 m) or less for outdoor applications. For exposure protection of vessels using rundown and slippage, e.g., exposure protection of vessels per NFPA 15 section 7.4.2 (2007 edition), the preceding recommendations apply.

Figures 6a and 6b indicate the distance from the nozzles to the tangent surface of the protected object at various fixed angles. The fixed angle is the included angle from pendent position being zero of spray nozzle position. The spray angle is the included angle of the spray nozzle pattern. The maximum distance is determined where the spray pattern angle is unchanged at the perpendicular position to tangent of fixed angle. The distances indicated are for 20 PSI (1.4 Bar) minimum, to 60 PSI (4.1 Bar) maximum residual pressure at the inlet of the nozzles. When Viking Model E Spray Nozzles are used to protect surfaces of vessels, they should be positioned normal to the surface being protected and approximately 2 ft. (.6 m) from the surface. Using the proper spray angle and K-Factor with this approach will provide the most effective protection and minimize effects of wind or draft conditions on the water spray pattern of the nozzles.

#### Installation Precaution

As a nozzle is being installed farther from the plane of protection, the centerline that is perpendicular to the plane of protection is potentially offset with the center/target of plane of protection due to installation error. Take extra care when locating a nozzle far from the plane of protection. Recommendation: Overlap spray patterns to provide a safety factor in the installation.

#### Notes About Pressure Requirements (Figures 6a & 6b)

1. Working pressures of 10 to 60 PSI (.7 to 4.1 Bar) can only be applied for 0° (vertically downward) orientation.
2. Working pressures for orientation angles other than 0° are 20 to 60 PSI (1.4 to 4.1 Bar).
3. However, unless otherwise specified, when the nozzles are axially installed 2 ft. (.6 m) or less from the plane of protection, working pressures of 10 to 60 PSI (.7 to 4.1 Bar) can be applied on all installation angles.

#### Spray Patterns

The design spray pattern profiles of the Model E Spray Nozzles with included spray angles of 65° to 180° are given in the graph in Figures 1a and 1b for discharge pressures from 10 to 60 PSI (.7 to 4.1 Bar). When discharge pressures above this are applied, the coverage area will decrease because the spray pattern tends to draw inward at higher pressures. When applying discharge pressures higher than 60 PSI (4.1 Bar), consult the Viking Technical Services department.

In Figures 6a and 6b, the maximum axial distance between the nozzle tip and the tangential plane being protected using a fixed installation angle is given. The operating discharge pressures are 20 PSI to 60 PSI (1.4 to 4.1 Bar) for application of this data. It is recommended that overlap be applied when using nozzles for exposure protection in this method.

#### Pipeline Strainers

Orifice diameter is less than 3/8" (9.4 mm) for Model E Nozzles with K-Factors of 3.2, 2.3, 1.8, and 1.2. A pipeline strainer with a 1/8" (3.2 mm) or less perforation is required for FM Approval.

**IMPORTANT: Always refer to Bulletin Form No. F\_091699 - Care and Handling of Sprinklers. Viking spray nozzles are to be installed in accordance with the latest edition of Viking technical data, the appropriate standards of NFPA, FM Global, LPCB, APSAD, VdS or other similar organizations, and also with the provisions of governmental codes, ordinances, and standards, whenever applicable.**



TECHNICAL DATA

MODEL E SPRAY NOZZLES  
VK810 - VK817

The Viking Corporation, 210 N Industrial Park Drive, Hastings MI 49058

Telephone: 269-945-9501 Technical Services: 877-384-5464 Fax: 269-818-1680 Email: techsvcs@vikingcorp.com

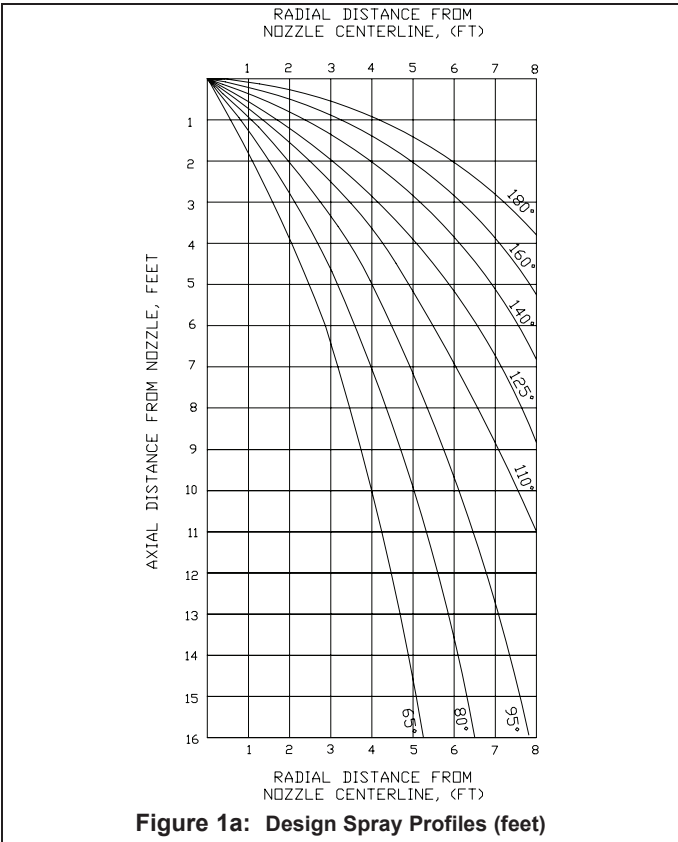


Figure 1a: Design Spray Profiles (feet)

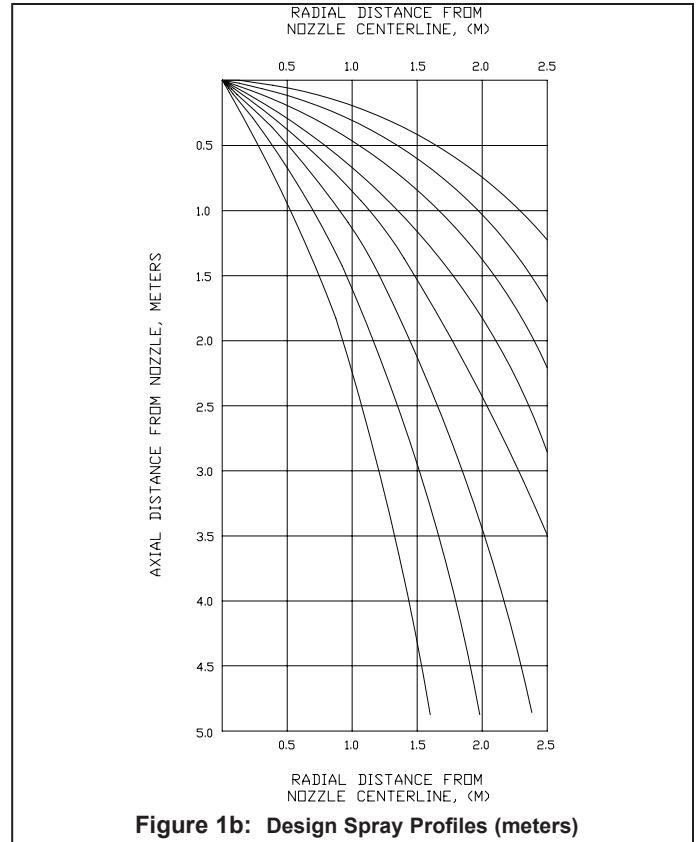


Figure 1b: Design Spray Profiles (meters)

NOTES:

1. Design data was obtained from tests in still air.
2. Design data applies to a residual (flowing) pressure range at the nozzle inlet of 10 to 60 PSI (.7 to 4.1 Bar). For pressures up to 175 PSI (12 Bar), consult the Viking Technical Services department toll free at 1-877-384-5464. Refer to the Authority Having Jurisdiction for their minimum required residual pressure.
3. The shapes of the Design Spray Profiles remain essentially unchanged over the maximum Axial Distances shown on pages 32h-i.
4. Maximum Axial Distances shown on pages 32h-i are based on exposure protection.

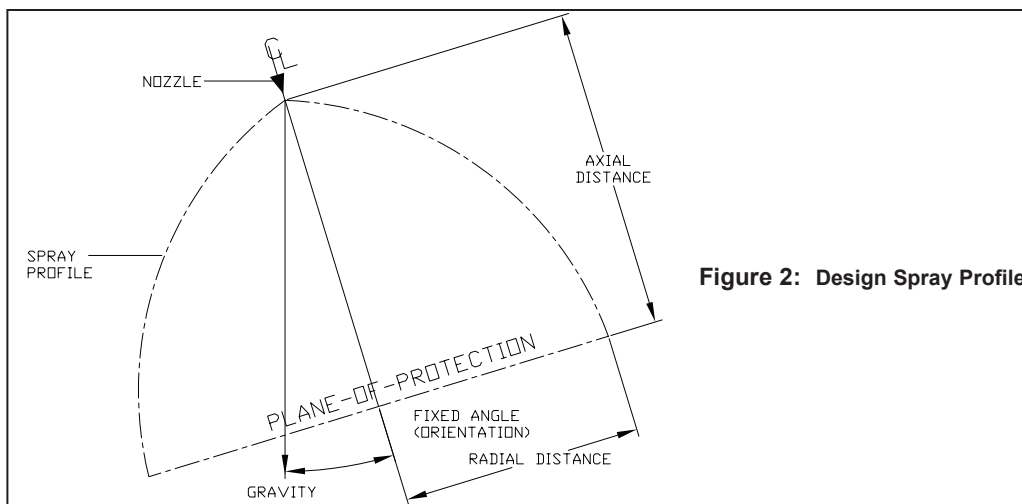


Figure 2: Design Spray Profile

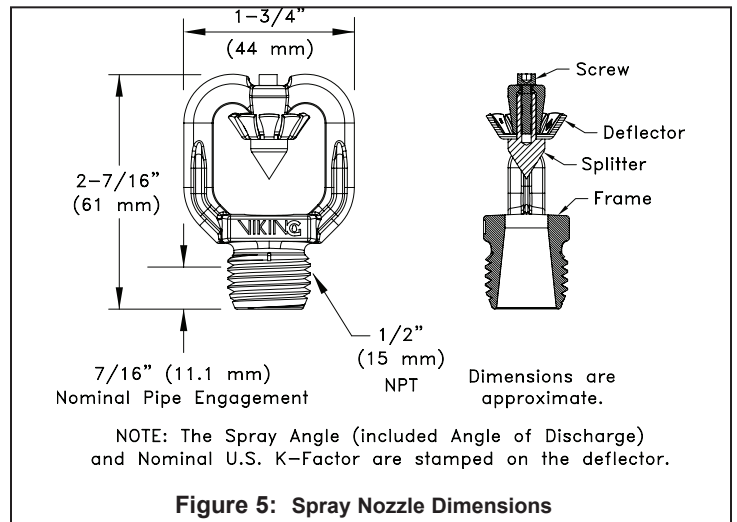
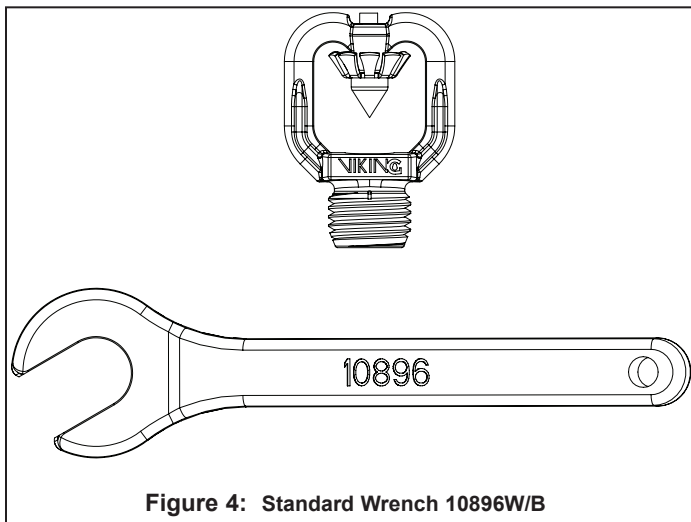
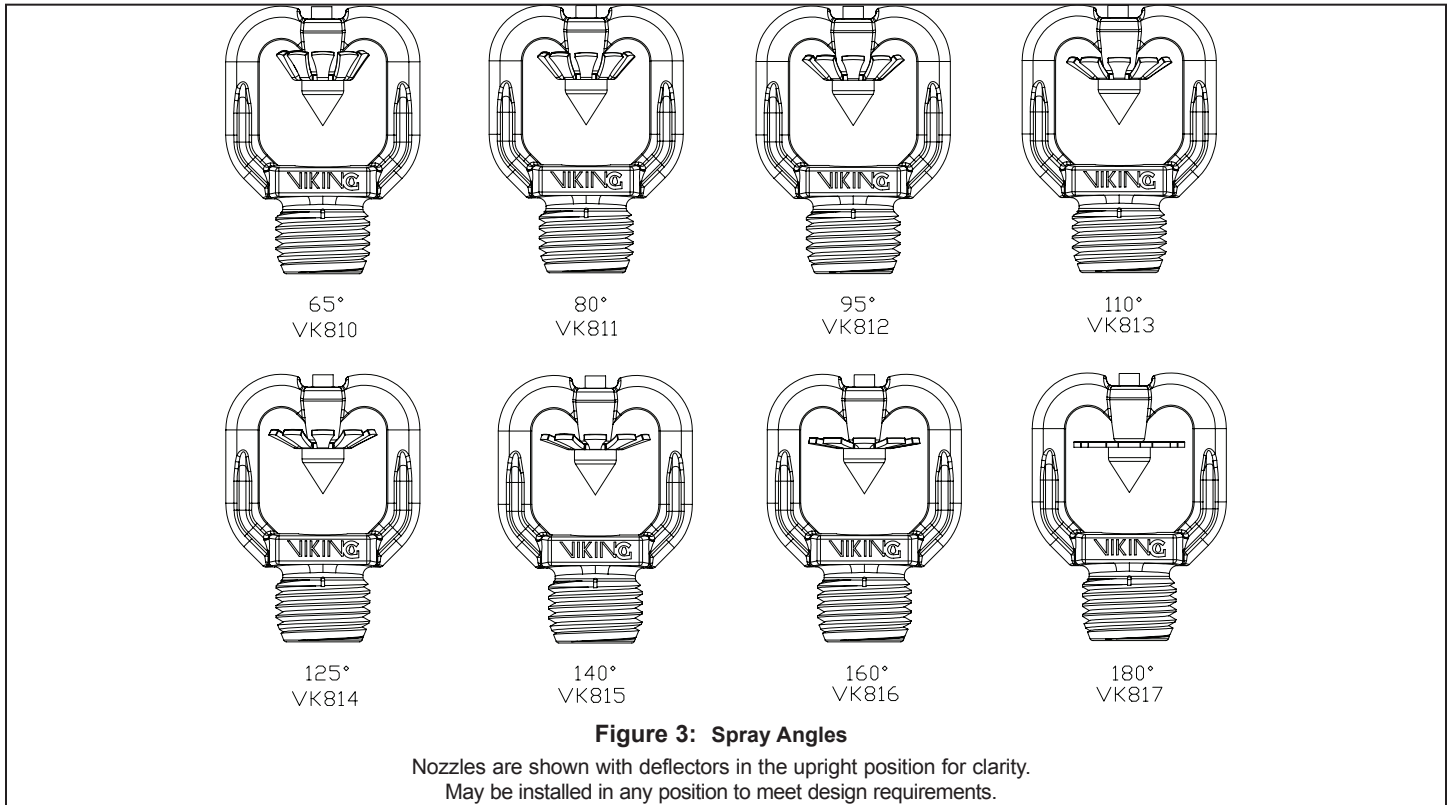





TECHNICAL DATA

MODEL E SPRAY NOZZLES  
VK810 - VK817

The Viking Corporation, 210 N Industrial Park Drive, Hastings MI 49058  
Telephone: 269-945-9501 Technical Services: 877-384-5464 Fax: 269-818-1680 Email: techsvcs@vikingcorp.com



	<h2 style="margin: 0;">TECHNICAL DATA</h2>	<h3 style="margin: 0;">MODEL E SPRAY NOZZLES VK810 - VK817</h3>
---	--	---

The Viking Corporation, 210 N Industrial Park Drive, Hastings MI 49058  
 Telephone: 269-945-9501 Technical Services: 877-384-5464 Fax: 269-818-1680 Email: techsvcs@vikingcorp.com

MAXIMUM AXIAL DISTANCE FOR 65° SPRAY ANGLE IN FEET AND INCHES							
FIXED ANGLE	K FACTOR						
	1.2	1.8	2.3	3.2	4.1	5.6	7.2
0°	16-0	16-0	16-0	16-0	16-0	16-0	16-0
30°	10	10-0	10-3	10-6	11-0	11-6	12-0
45°	8-0	8-0	8-3	8-9	9-0	9-6	10-0
60°	7-0	7-0	7-6	8-3	8-6	8-9	9-0
90°	6-6	6-9	7-0	7-6	8-0	8-0	8-6
120°	6-3	6-3	6-6	7-0	7-6	7-6	8-0
135°	6-0	6-0	6-3	6-6	7-0	7-0	7-6
150°	5-9	5-9	6-0	6-0	6-6	6-9	7-0
180°	5-0	5-0	5-3	5-6	6-0	6-6	6-9

MAXIMUM AXIAL DISTANCE FOR 125° SPRAY ANGLE IN FEET AND INCHES							
FIXED ANGLE	K FACTOR						
	1.2	1.8	2.3	3.2	4.1	5.6	7.2
0°	9-0	9-0	9-0	9-0	9-0	9-0	9-0
30°	4-9	4-9	5-3	6-0	7-0	7-3	8-0
45°	4-6	4-6	4-9	5-0	6-0	6-6	7-0
60°	3-6	3-6	3-9	4-0	5-0	5-6	6-0
90°	3-0	3-0	3-3	3-6	4-6	4-9	5-6
120°	2-0	2-0	2-6	3-3	3-9	3-9	4-0
135°	1-9	1-9	2-3	3-0	3-6	3-6	3-9
150°	1-6	1-9	2-3	2-6	3-0	3-3	3-6
180°	1-3	1-6	2-0	2-6	2-9	3-0	3-3

MAXIMUM AXIAL DISTANCE FOR 80° SPRAY ANGLE IN FEET AND INCHES							
FIXED ANGLE	K FACTOR						
	1.2	1.8	2.3	3.2	4.1	5.6	7.2
0°	16-0	16-0	16-0	16-0	16-0	16-0	16-0
30°	9-6	9-6	10-0	10-6	11-0	11-3	11-6
45°	7-6	7-6	8-0	8-3	8-6	9-0	9-9
60°	6-0	6-3	6-6	7-0	7-0	8-0	8-6
90°	5-6	6-0	6-3	6-6	6-9	7-6	8-0
120°	5-0	5-3	5-9	6-0	6-6	6-6	7-0
135°	4-6	5-3	5-6	5-9	6-0	6-3	6-6
150°	4-3	4-6	4-9	5-6	5-9	6-0	6-0
180°	4-0	4-3	4-6	5-3	5-6	5-9	5-9

MAXIMUM AXIAL DISTANCE FOR 140° SPRAY ANGLE IN FEET AND INCHES							
FIXED ANGLE	K FACTOR						
	1.2	1.8	2.3	3.2	4.1	5.6	7.2
0°	7-0	7-0	7-0	7-0	7-0	7-0	7-0
30°	3-6	4-0	4-6	5-0	5-6	5-6	6-0
45°	3-3	3-6	3-9	4-3	4-6	5-0	5-3
60°	2-3	2-3	2-6	3-6	4-0	4-3	4-6
90°	2-0	2-0	2-9	3-0	3-6	3-6	4-0
120°	1-9	1-9	2-3	2-9	3-0	3-3	3-6
135°	1-6	1-6	1-9	2-3	2-6	2-9	3-0
150°	1-3	1-3	1-6	1-9	2-0	2-3	2-6
180°	1-0	1-0	1-6	1-6	1-9	2-0	2-3

MAXIMUM AXIAL DISTANCE FOR 95° SPRAY ANGLE IN FEET AND INCHES							
FIXED ANGLE	K FACTOR						
	1.2	1.8	2.3	3.2	4.1	5.6	7.2
0°	16-0	16-0	16-0	16-0	16-0	16-0	16-0
30°	8-0	8-3	9-0	9-6	10-6	11-0	11-6
45°	7-0	7-0	7-3	7-6	8-0	8-9	9-6
60°	5-0	5-3	5-6	6-3	6-6	7-0	8-0
90°	4-6	5-0	5-3	5-6	6-0	6-6	7-0
120°	4-0	4-3	4-9	5-3	5-6	5-6	6-0
135°	3-6	3-9	4-3	4-9	5-0	5-3	5-6
150°	3-3	3-6	3-6	4-6	4-9	5-0	5-0
180°	3-0	3-3	3-3	4-0	4-6	4-9	4-9

MAXIMUM AXIAL DISTANCE FOR 160° SPRAY ANGLE IN FEET AND INCHES							
FIXED ANGLE	K FACTOR						
	1.2	1.8	2.3	3.2	4.1	5.6	7.2
0°	5-6	5-6	5-6	5-6	5-6	5-6	5-6
30°	4-0	4-0	4-0	4-3	4-9	4-9	5-0
45°	3-0	3-0	3-3	3-6	3-9	3-9	4-0
60°	2-0	2-0	2-0	2-6	3-0	3-3	3-3
90°	1-0	1-3	1-9	2-0	2-6	2-6	3-0
120°	NR	1-0	1-6	1-9	2-0	2-3	2-6
135°	NR	NR	1-0	1-6	1-9	1-9	2-0
150°	NR	NR	NR	1-0	1-2	1-6	1-9
180°	NR	NR	NR	1-0	1-0	1-3	1-6

MAXIMUM AXIAL DISTANCE FOR 110° SPRAY ANGLE IN FEET AND INCHES							
FIXED ANGLE	K FACTOR						
	1.2	1.8	2.3	3.2	4.1	5.6	7.2
0°	11-0	11-0	11-0	11-0	11-0	11-0	11-0
30°	6-6	6-6	7-3	8-3	9-0	9-3	9-6
45°	5-6	5-9	6-6	7-0	7-6	8-0	8-6
60°	4-9	5-0	5-3	5-6	6-0	7-0	7-6
90°	4-0	4-0	4-6	5-0	5-6	6-0	6-6
120°	3-0	3-3	3-9	4-0	4-6	4-9	5-0
135°	2-9	2-9	3-3	3-9	4-3	4-6	4-9
150°	2-6	2-9	3-0	3-6	3-9	4-2	4-6
180°	2-3	2-6	3-0	3-3	3-6	4-0	4-3


MAXIMUM AXIAL DISTANCE FOR 180° SPRAY ANGLE IN FEET AND INCHES							
FIXED ANGLE	K FACTOR						
	1.2	1.8	2.3	3.2	4.1	5.6	7.2
0°	4-0	4-0	4-0	4-0	4-0	4-0	4-0
30°	2-3	2-3	2-6	2-9	3-0	3-0	3-0
45°	2-0	2-0	2-0	2-3	2-6	2-9	2-9
60°	1-6	1-6	1-9	2-0	2-3	2-6	2-6
90°	NR	NR	1-0	1-0	1-6	1-9	2-3
120°	NR	NR	1-0	1-0	1-3	1-6	1-9
135°	NR	NR	NR	1-0	1-0	1-3	1-6
150°	NR	NR	NR	NR	1-0	1-3	1-3
180°	NR	NR	NR	NR	NR	1-0	1-0

NR = Not Recommended

**Figure 6a: Maximum Axial Distance Between Nozzle Tip  
and Plane of Protection for Exposure Protection (ft)**

**NOTES ABOUT FIGURES 6a AND 6b:**

1. Working pressures of 10 to 60 PSI (.7 to 4.1 Bar) can only be applied for 0° (vertically downward) orientation.
2. Working pressures for orientation angles other than 0° are 20 to 60 PSI (1.4 to 4.1 Bar).
3. However, unless otherwise specified, when the nozzles are axially installed 2 ft. (.6 m) or less from the plane of protection, working pressures of 10 to 60 PSI (.7 to 4.1 Bar) can be applied on all installation angles.

	<b>TECHNICAL DATA</b>	<b>MODEL E SPRAY NOZZLES VK810 - VK817</b>
---	-----------------------	--

The Viking Corporation, 210 N Industrial Park Drive, Hastings MI 49058  
 Telephone: 269-945-9501 Technical Services: 877-384-5464 Fax: 269-818-1680 Email: techsvcs@vikingcorp.com

<table border="1" style="width: 100%; border-collapse: collapse;"> <tr><th colspan="8">MAXIMUM AXIAL DISTANCE FOR 65° SPRAY ANGLE IN METERS</th></tr> <tr><th>FIXED ANGLE</th><th colspan="7">K FACTOR (METRIC)</th></tr> <tr><th></th><th>17.3</th><th>25.9</th><th>33.1</th><th>46.1</th><th>59.0</th><th>80.6</th><th>103.7</th></tr> <tr><td>0°</td><td>4.9</td><td>4.9</td><td>4.9</td><td>4.9</td><td>4.9</td><td>4.9</td><td>4.9</td></tr> <tr><td>30°</td><td>3.0</td><td>3.0</td><td>3.1</td><td>3.2</td><td>3.4</td><td>3.5</td><td>3.7</td></tr> <tr><td>45°</td><td>2.4</td><td>2.4</td><td>2.5</td><td>2.7</td><td>2.7</td><td>2.9</td><td>3.0</td></tr> <tr><td>60°</td><td>2.1</td><td>2.1</td><td>2.3</td><td>2.5</td><td>2.6</td><td>2.7</td><td>2.7</td></tr> <tr><td>90°</td><td>2.0</td><td>2.1</td><td>2.1</td><td>2.3</td><td>2.4</td><td>2.4</td><td>2.6</td></tr> <tr><td>120°</td><td>1.9</td><td>1.9</td><td>2.0</td><td>2.1</td><td>2.3</td><td>2.3</td><td>2.4</td></tr> <tr><td>135°</td><td>1.8</td><td>1.8</td><td>1.9</td><td>2.0</td><td>2.1</td><td>2.1</td><td>2.3</td></tr> <tr><td>150°</td><td>1.8</td><td>1.8</td><td>1.8</td><td>1.8</td><td>2.0</td><td>2.1</td><td>2.1</td></tr> <tr><td>180°</td><td>1.5</td><td>1.5</td><td>1.6</td><td>1.7</td><td>1.8</td><td>2.0</td><td>2.1</td></tr> </table>	MAXIMUM AXIAL DISTANCE FOR 65° SPRAY ANGLE IN METERS								FIXED ANGLE	K FACTOR (METRIC)								17.3	25.9	33.1	46.1	59.0	80.6	103.7	0°	4.9	4.9	4.9	4.9	4.9	4.9	4.9	30°	3.0	3.0	3.1	3.2	3.4	3.5	3.7	45°	2.4	2.4	2.5	2.7	2.7	2.9	3.0	60°	2.1	2.1	2.3	2.5	2.6	2.7	2.7	90°	2.0	2.1	2.1	2.3	2.4	2.4	2.6	120°	1.9	1.9	2.0	2.1	2.3	2.3	2.4	135°	1.8	1.8	1.9	2.0	2.1	2.1	2.3	150°	1.8	1.8	1.8	1.8	2.0	2.1	2.1	180°	1.5	1.5	1.6	1.7	1.8	2.0	2.1	<table border="1" style="width: 100%; border-collapse: collapse;"> <tr><th colspan="8">MAXIMUM AXIAL DISTANCE FOR 125° SPRAY ANGLE IN METERS</th></tr> <tr><th>FIXED ANGLE</th><th colspan="7">K FACTOR (METRIC)</th></tr> <tr><th></th><th>17.3</th><th>25.9</th><th>33.1</th><th>46.1</th><th>59.0</th><th>80.6</th><th>103.7</th></tr> <tr><td>0°</td><td>2.7</td><td>2.7</td><td>2.7</td><td>2.7</td><td>2.7</td><td>2.7</td><td>2.7</td></tr> <tr><td>30°</td><td>1.4</td><td>1.4</td><td>1.6</td><td>1.8</td><td>2.1</td><td>2.2</td><td>2.4</td></tr> <tr><td>45°</td><td>1.4</td><td>1.4</td><td>1.4</td><td>1.5</td><td>1.8</td><td>2.0</td><td>2.1</td></tr> <tr><td>60°</td><td>1.1</td><td>1.1</td><td>1.1</td><td>1.2</td><td>1.5</td><td>1.7</td><td>1.8</td></tr> <tr><td>90°</td><td>0.9</td><td>0.9</td><td>1.0</td><td>1.1</td><td>1.4</td><td>1.4</td><td>1.7</td></tr> <tr><td>120°</td><td>0.6</td><td>0.6</td><td>0.8</td><td>1.0</td><td>1.1</td><td>1.1</td><td>1.2</td></tr> <tr><td>135°</td><td>0.5</td><td>0.5</td><td>0.7</td><td>0.9</td><td>1.1</td><td>1.1</td><td>1.1</td></tr> <tr><td>150°</td><td>0.5</td><td>0.5</td><td>0.7</td><td>0.8</td><td>0.9</td><td>1.0</td><td>1.1</td></tr> <tr><td>180°</td><td>0.4</td><td>0.5</td><td>0.6</td><td>0.8</td><td>0.8</td><td>0.9</td><td>1.0</td></tr> </table>	MAXIMUM AXIAL DISTANCE FOR 125° SPRAY ANGLE IN METERS								FIXED ANGLE	K FACTOR (METRIC)								17.3	25.9	33.1	46.1	59.0	80.6	103.7	0°	2.7	2.7	2.7	2.7	2.7	2.7	2.7	30°	1.4	1.4	1.6	1.8	2.1	2.2	2.4	45°	1.4	1.4	1.4	1.5	1.8	2.0	2.1	60°	1.1	1.1	1.1	1.2	1.5	1.7	1.8	90°	0.9	0.9	1.0	1.1	1.4	1.4	1.7	120°	0.6	0.6	0.8	1.0	1.1	1.1	1.2	135°	0.5	0.5	0.7	0.9	1.1	1.1	1.1	150°	0.5	0.5	0.7	0.8	0.9	1.0	1.1	180°	0.4	0.5	0.6	0.8	0.8	0.9	1.0
MAXIMUM AXIAL DISTANCE FOR 65° SPRAY ANGLE IN METERS																																																																																																																																																																																																	
FIXED ANGLE	K FACTOR (METRIC)																																																																																																																																																																																																
	17.3	25.9	33.1	46.1	59.0	80.6	103.7																																																																																																																																																																																										
0°	4.9	4.9	4.9	4.9	4.9	4.9	4.9																																																																																																																																																																																										
30°	3.0	3.0	3.1	3.2	3.4	3.5	3.7																																																																																																																																																																																										
45°	2.4	2.4	2.5	2.7	2.7	2.9	3.0																																																																																																																																																																																										
60°	2.1	2.1	2.3	2.5	2.6	2.7	2.7																																																																																																																																																																																										
90°	2.0	2.1	2.1	2.3	2.4	2.4	2.6																																																																																																																																																																																										
120°	1.9	1.9	2.0	2.1	2.3	2.3	2.4																																																																																																																																																																																										
135°	1.8	1.8	1.9	2.0	2.1	2.1	2.3																																																																																																																																																																																										
150°	1.8	1.8	1.8	1.8	2.0	2.1	2.1																																																																																																																																																																																										
180°	1.5	1.5	1.6	1.7	1.8	2.0	2.1																																																																																																																																																																																										
MAXIMUM AXIAL DISTANCE FOR 125° SPRAY ANGLE IN METERS																																																																																																																																																																																																	
FIXED ANGLE	K FACTOR (METRIC)																																																																																																																																																																																																
	17.3	25.9	33.1	46.1	59.0	80.6	103.7																																																																																																																																																																																										
0°	2.7	2.7	2.7	2.7	2.7	2.7	2.7																																																																																																																																																																																										
30°	1.4	1.4	1.6	1.8	2.1	2.2	2.4																																																																																																																																																																																										
45°	1.4	1.4	1.4	1.5	1.8	2.0	2.1																																																																																																																																																																																										
60°	1.1	1.1	1.1	1.2	1.5	1.7	1.8																																																																																																																																																																																										
90°	0.9	0.9	1.0	1.1	1.4	1.4	1.7																																																																																																																																																																																										
120°	0.6	0.6	0.8	1.0	1.1	1.1	1.2																																																																																																																																																																																										
135°	0.5	0.5	0.7	0.9	1.1	1.1	1.1																																																																																																																																																																																										
150°	0.5	0.5	0.7	0.8	0.9	1.0	1.1																																																																																																																																																																																										
180°	0.4	0.5	0.6	0.8	0.8	0.9	1.0																																																																																																																																																																																										
<table border="1" style="width: 100%; border-collapse: collapse;"> <tr><th colspan="8">MAXIMUM AXIAL DISTANCE FOR 80° SPRAY ANGLE IN METERS</th></tr> <tr><th>FIXED ANGLE</th><th colspan="7">K FACTOR (METRIC)</th></tr> <tr><th></th><th>17.3</th><th>25.9</th><th>33.1</th><th>46.1</th><th>59.0</th><th>80.6</th><th>103.7</th></tr> <tr><td>0°</td><td>4.9</td><td>4.9</td><td>4.9</td><td>4.9</td><td>4.9</td><td>4.9</td><td>4.9</td></tr> <tr><td>30°</td><td>3.0</td><td>3.0</td><td>3.0</td><td>3.2</td><td>3.4</td><td>3.4</td><td>3.5</td></tr> <tr><td>45°</td><td>2.3</td><td>2.3</td><td>2.4</td><td>2.5</td><td>2.6</td><td>2.7</td><td>3.0</td></tr> <tr><td>60°</td><td>1.8</td><td>1.9</td><td>2.0</td><td>2.1</td><td>2.1</td><td>2.4</td><td>2.6</td></tr> <tr><td>90°</td><td>1.7</td><td>1.8</td><td>1.9</td><td>2.0</td><td>2.1</td><td>2.3</td><td>2.4</td></tr> <tr><td>120°</td><td>1.5</td><td>1.6</td><td>1.8</td><td>1.8</td><td>2.0</td><td>2.0</td><td>2.1</td></tr> <tr><td>135°</td><td>1.4</td><td>1.6</td><td>1.7</td><td>1.8</td><td>1.8</td><td>1.9</td><td>2.0</td></tr> <tr><td>150°</td><td>1.3</td><td>1.4</td><td>1.4</td><td>1.7</td><td>1.8</td><td>1.8</td><td>1.8</td></tr> <tr><td>180°</td><td>1.2</td><td>1.3</td><td>1.4</td><td>1.6</td><td>1.7</td><td>1.8</td><td>1.8</td></tr> </table>	MAXIMUM AXIAL DISTANCE FOR 80° SPRAY ANGLE IN METERS								FIXED ANGLE	K FACTOR (METRIC)								17.3	25.9	33.1	46.1	59.0	80.6	103.7	0°	4.9	4.9	4.9	4.9	4.9	4.9	4.9	30°	3.0	3.0	3.0	3.2	3.4	3.4	3.5	45°	2.3	2.3	2.4	2.5	2.6	2.7	3.0	60°	1.8	1.9	2.0	2.1	2.1	2.4	2.6	90°	1.7	1.8	1.9	2.0	2.1	2.3	2.4	120°	1.5	1.6	1.8	1.8	2.0	2.0	2.1	135°	1.4	1.6	1.7	1.8	1.8	1.9	2.0	150°	1.3	1.4	1.4	1.7	1.8	1.8	1.8	180°	1.2	1.3	1.4	1.6	1.7	1.8	1.8	<table border="1" style="width: 100%; border-collapse: collapse;"> <tr><th colspan="8">MAXIMUM AXIAL DISTANCE FOR 140° SPRAY ANGLE IN METERS</th></tr> <tr><th>FIXED ANGLE</th><th colspan="7">K FACTOR (METRIC)</th></tr> <tr><th></th><th>17.3</th><th>25.9</th><th>33.1</th><th>46.1</th><th>59.0</th><th>80.6</th><th>103.7</th></tr> <tr><td>0°</td><td>2.1</td><td>2.1</td><td>2.1</td><td>2.1</td><td>2.1</td><td>2.1</td><td>2.1</td></tr> <tr><td>30°</td><td>1.1</td><td>1.2</td><td>1.4</td><td>1.5</td><td>1.7</td><td>1.7</td><td>1.8</td></tr> <tr><td>45°</td><td>1.0</td><td>1.1</td><td>1.1</td><td>1.3</td><td>1.4</td><td>1.5</td><td>1.6</td></tr> <tr><td>60°</td><td>0.7</td><td>0.7</td><td>0.8</td><td>1.1</td><td>1.2</td><td>1.3</td><td>1.4</td></tr> <tr><td>90°</td><td>0.6</td><td>0.6</td><td>0.8</td><td>0.9</td><td>1.1</td><td>1.1</td><td>1.2</td></tr> <tr><td>120°</td><td>0.5</td><td>0.5</td><td>0.7</td><td>0.8</td><td>0.9</td><td>1.0</td><td>1.1</td></tr> <tr><td>135°</td><td>0.5</td><td>0.5</td><td>0.5</td><td>0.7</td><td>0.8</td><td>0.8</td><td>0.9</td></tr> <tr><td>150°</td><td>0.4</td><td>0.4</td><td>0.5</td><td>0.5</td><td>0.6</td><td>0.7</td><td>0.8</td></tr> <tr><td>180°</td><td>0.3</td><td>0.3</td><td>0.5</td><td>0.5</td><td>0.5</td><td>0.6</td><td>0.7</td></tr> </table>	MAXIMUM AXIAL DISTANCE FOR 140° SPRAY ANGLE IN METERS								FIXED ANGLE	K FACTOR (METRIC)								17.3	25.9	33.1	46.1	59.0	80.6	103.7	0°	2.1	2.1	2.1	2.1	2.1	2.1	2.1	30°	1.1	1.2	1.4	1.5	1.7	1.7	1.8	45°	1.0	1.1	1.1	1.3	1.4	1.5	1.6	60°	0.7	0.7	0.8	1.1	1.2	1.3	1.4	90°	0.6	0.6	0.8	0.9	1.1	1.1	1.2	120°	0.5	0.5	0.7	0.8	0.9	1.0	1.1	135°	0.5	0.5	0.5	0.7	0.8	0.8	0.9	150°	0.4	0.4	0.5	0.5	0.6	0.7	0.8	180°	0.3	0.3	0.5	0.5	0.5	0.6	0.7
MAXIMUM AXIAL DISTANCE FOR 80° SPRAY ANGLE IN METERS																																																																																																																																																																																																	
FIXED ANGLE	K FACTOR (METRIC)																																																																																																																																																																																																
	17.3	25.9	33.1	46.1	59.0	80.6	103.7																																																																																																																																																																																										
0°	4.9	4.9	4.9	4.9	4.9	4.9	4.9																																																																																																																																																																																										
30°	3.0	3.0	3.0	3.2	3.4	3.4	3.5																																																																																																																																																																																										
45°	2.3	2.3	2.4	2.5	2.6	2.7	3.0																																																																																																																																																																																										
60°	1.8	1.9	2.0	2.1	2.1	2.4	2.6																																																																																																																																																																																										
90°	1.7	1.8	1.9	2.0	2.1	2.3	2.4																																																																																																																																																																																										
120°	1.5	1.6	1.8	1.8	2.0	2.0	2.1																																																																																																																																																																																										
135°	1.4	1.6	1.7	1.8	1.8	1.9	2.0																																																																																																																																																																																										
150°	1.3	1.4	1.4	1.7	1.8	1.8	1.8																																																																																																																																																																																										
180°	1.2	1.3	1.4	1.6	1.7	1.8	1.8																																																																																																																																																																																										
MAXIMUM AXIAL DISTANCE FOR 140° SPRAY ANGLE IN METERS																																																																																																																																																																																																	
FIXED ANGLE	K FACTOR (METRIC)																																																																																																																																																																																																
	17.3	25.9	33.1	46.1	59.0	80.6	103.7																																																																																																																																																																																										
0°	2.1	2.1	2.1	2.1	2.1	2.1	2.1																																																																																																																																																																																										
30°	1.1	1.2	1.4	1.5	1.7	1.7	1.8																																																																																																																																																																																										
45°	1.0	1.1	1.1	1.3	1.4	1.5	1.6																																																																																																																																																																																										
60°	0.7	0.7	0.8	1.1	1.2	1.3	1.4																																																																																																																																																																																										
90°	0.6	0.6	0.8	0.9	1.1	1.1	1.2																																																																																																																																																																																										
120°	0.5	0.5	0.7	0.8	0.9	1.0	1.1																																																																																																																																																																																										
135°	0.5	0.5	0.5	0.7	0.8	0.8	0.9																																																																																																																																																																																										
150°	0.4	0.4	0.5	0.5	0.6	0.7	0.8																																																																																																																																																																																										
180°	0.3	0.3	0.5	0.5	0.5	0.6	0.7																																																																																																																																																																																										
<table border="1" style="width: 100%; border-collapse: collapse;"> <tr><th colspan="8">MAXIMUM AXIAL DISTANCE FOR 95° SPRAY ANGLE IN METERS</th></tr> <tr><th>FIXED ANGLE</th><th colspan="7">K FACTOR (METRIC)</th></tr> <tr><th></th><th>17.3</th><th>25.9</th><th>33.1</th><th>46.1</th><th>59.0</th><th>80.6</th><th>103.7</th></tr> <tr><td>0°</td><td>4.9</td><td>4.9</td><td>4.9</td><td>4.9</td><td>4.9</td><td>4.9</td><td>4.9</td></tr> <tr><td>30°</td><td>2.4</td><td>2.5</td><td>2.7</td><td>2.9</td><td>3.2</td><td>3.4</td><td>3.5</td></tr> <tr><td>45°</td><td>2.1</td><td>2.1</td><td>2.2</td><td>2.3</td><td>2.4</td><td>2.7</td><td>2.9</td></tr> <tr><td>60°</td><td>1.5</td><td>1.6</td><td>1.7</td><td>1.9</td><td>2.0</td><td>2.1</td><td>2.4</td></tr> <tr><td>90°</td><td>1.4</td><td>1.5</td><td>1.6</td><td>1.7</td><td>1.8</td><td>2.0</td><td>2.1</td></tr> <tr><td>120°</td><td>1.2</td><td>1.3</td><td>1.4</td><td>1.6</td><td>1.7</td><td>1.7</td><td>1.8</td></tr> <tr><td>135°</td><td>1.1</td><td>1.1</td><td>1.3</td><td>1.4</td><td>1.5</td><td>1.6</td><td>1.7</td></tr> <tr><td>150°</td><td>1.0</td><td>1.1</td><td>1.1</td><td>1.4</td><td>1.4</td><td>1.5</td><td>1.5</td></tr> <tr><td>180°</td><td>0.9</td><td>1.0</td><td>1.0</td><td>1.2</td><td>1.4</td><td>1.4</td><td>1.4</td></tr> </table>	MAXIMUM AXIAL DISTANCE FOR 95° SPRAY ANGLE IN METERS								FIXED ANGLE	K FACTOR (METRIC)								17.3	25.9	33.1	46.1	59.0	80.6	103.7	0°	4.9	4.9	4.9	4.9	4.9	4.9	4.9	30°	2.4	2.5	2.7	2.9	3.2	3.4	3.5	45°	2.1	2.1	2.2	2.3	2.4	2.7	2.9	60°	1.5	1.6	1.7	1.9	2.0	2.1	2.4	90°	1.4	1.5	1.6	1.7	1.8	2.0	2.1	120°	1.2	1.3	1.4	1.6	1.7	1.7	1.8	135°	1.1	1.1	1.3	1.4	1.5	1.6	1.7	150°	1.0	1.1	1.1	1.4	1.4	1.5	1.5	180°	0.9	1.0	1.0	1.2	1.4	1.4	1.4	<table border="1" style="width: 100%; border-collapse: collapse;"> <tr><th colspan="8">MAXIMUM AXIAL DISTANCE FOR 160° SPRAY ANGLE IN METERS</th></tr> <tr><th>FIXED ANGLE</th><th colspan="7">K FACTOR (METRIC)</th></tr> <tr><th></th><th>17.3</th><th>25.9</th><th>33.1</th><th>46.1</th><th>59.0</th><th>80.6</th><th>103.7</th></tr> <tr><td>0°</td><td>1.7</td><td>1.7</td><td>1.7</td><td>1.7</td><td>1.7</td><td>1.7</td><td>1.7</td></tr> <tr><td>30°</td><td>4.3</td><td>1.2</td><td>1.2</td><td>1.3</td><td>1.4</td><td>1.4</td><td>1.5</td></tr> <tr><td>45°</td><td>0.9</td><td>0.9</td><td>1.0</td><td>1.1</td><td>1.1</td><td>1.1</td><td>1.2</td></tr> <tr><td>60°</td><td>0.6</td><td>0.6</td><td>0.6</td><td>0.8</td><td>0.9</td><td>1.0</td><td>1.0</td></tr> <tr><td>90°</td><td>0.3</td><td>0.4</td><td>0.5</td><td>0.6</td><td>0.8</td><td>0.8</td><td>0.9</td></tr> <tr><td>120°</td><td>NR</td><td>0.3</td><td>0.4</td><td>0.5</td><td>0.6</td><td>0.7</td><td>0.8</td></tr> <tr><td>135°</td><td>NR</td><td>NR</td><td>0.3</td><td>0.5</td><td>0.5</td><td>0.5</td><td>0.6</td></tr> <tr><td>150°</td><td>NR</td><td>NR</td><td>NR</td><td>0.3</td><td>0.4</td><td>0.5</td><td>0.5</td></tr> <tr><td>180°</td><td>NR</td><td>NR</td><td>NR</td><td>0.3</td><td>0.3</td><td>0.4</td><td>0.5</td></tr> </table>	MAXIMUM AXIAL DISTANCE FOR 160° SPRAY ANGLE IN METERS								FIXED ANGLE	K FACTOR (METRIC)								17.3	25.9	33.1	46.1	59.0	80.6	103.7	0°	1.7	1.7	1.7	1.7	1.7	1.7	1.7	30°	4.3	1.2	1.2	1.3	1.4	1.4	1.5	45°	0.9	0.9	1.0	1.1	1.1	1.1	1.2	60°	0.6	0.6	0.6	0.8	0.9	1.0	1.0	90°	0.3	0.4	0.5	0.6	0.8	0.8	0.9	120°	NR	0.3	0.4	0.5	0.6	0.7	0.8	135°	NR	NR	0.3	0.5	0.5	0.5	0.6	150°	NR	NR	NR	0.3	0.4	0.5	0.5	180°	NR	NR	NR	0.3	0.3	0.4	0.5
MAXIMUM AXIAL DISTANCE FOR 95° SPRAY ANGLE IN METERS																																																																																																																																																																																																	
FIXED ANGLE	K FACTOR (METRIC)																																																																																																																																																																																																
	17.3	25.9	33.1	46.1	59.0	80.6	103.7																																																																																																																																																																																										
0°	4.9	4.9	4.9	4.9	4.9	4.9	4.9																																																																																																																																																																																										
30°	2.4	2.5	2.7	2.9	3.2	3.4	3.5																																																																																																																																																																																										
45°	2.1	2.1	2.2	2.3	2.4	2.7	2.9																																																																																																																																																																																										
60°	1.5	1.6	1.7	1.9	2.0	2.1	2.4																																																																																																																																																																																										
90°	1.4	1.5	1.6	1.7	1.8	2.0	2.1																																																																																																																																																																																										
120°	1.2	1.3	1.4	1.6	1.7	1.7	1.8																																																																																																																																																																																										
135°	1.1	1.1	1.3	1.4	1.5	1.6	1.7																																																																																																																																																																																										
150°	1.0	1.1	1.1	1.4	1.4	1.5	1.5																																																																																																																																																																																										
180°	0.9	1.0	1.0	1.2	1.4	1.4	1.4																																																																																																																																																																																										
MAXIMUM AXIAL DISTANCE FOR 160° SPRAY ANGLE IN METERS																																																																																																																																																																																																	
FIXED ANGLE	K FACTOR (METRIC)																																																																																																																																																																																																
	17.3	25.9	33.1	46.1	59.0	80.6	103.7																																																																																																																																																																																										
0°	1.7	1.7	1.7	1.7	1.7	1.7	1.7																																																																																																																																																																																										
30°	4.3	1.2	1.2	1.3	1.4	1.4	1.5																																																																																																																																																																																										
45°	0.9	0.9	1.0	1.1	1.1	1.1	1.2																																																																																																																																																																																										
60°	0.6	0.6	0.6	0.8	0.9	1.0	1.0																																																																																																																																																																																										
90°	0.3	0.4	0.5	0.6	0.8	0.8	0.9																																																																																																																																																																																										
120°	NR	0.3	0.4	0.5	0.6	0.7	0.8																																																																																																																																																																																										
135°	NR	NR	0.3	0.5	0.5	0.5	0.6																																																																																																																																																																																										
150°	NR	NR	NR	0.3	0.4	0.5	0.5																																																																																																																																																																																										
180°	NR	NR	NR	0.3	0.3	0.4	0.5																																																																																																																																																																																										
<table border="1" style="width: 100%; border-collapse: collapse;"> <tr><th colspan="8">MAXIMUM AXIAL DISTANCE FOR 110° SPRAY ANGLE IN METERS</th></tr> <tr><th>FIXED ANGLE</th><th colspan="7">K FACTOR (METRIC)</th></tr> <tr><th></th><th>17.3</th><th>25.9</th><th>33.1</th><th>46.1</th><th>59.0</th><th>80.6</th><th>103.7</th></tr> <tr><td>0°</td><td>3.4</td><td>3.4</td><td>3.4</td><td>3.4</td><td>3.4</td><td>3.4</td><td>3.4</td></tr> <tr><td>30°</td><td>2.0</td><td>2.0</td><td>2.2</td><td>2.5</td><td>2.7</td><td>2.8</td><td>3.0</td></tr> <tr><td>45°</td><td>1.7</td><td>1.8</td><td>2.0</td><td>2.1</td><td>2.3</td><td>2.4</td><td>2.6</td></tr> <tr><td>60°</td><td>1.4</td><td>1.5</td><td>1.6</td><td>1.7</td><td>1.8</td><td>2.1</td><td>2.2</td></tr> <tr><td>90°</td><td>1.2</td><td>1.2</td><td>1.4</td><td>1.5</td><td>1.7</td><td>1.8</td><td>2.0</td></tr> <tr><td>120°</td><td>0.9</td><td>1.0</td><td>1.1</td><td>1.2</td><td>1.4</td><td>1.4</td><td>1.5</td></tr> <tr><td>135°</td><td>0.8</td><td>0.8</td><td>1.0</td><td>1.1</td><td>1.3</td><td>1.4</td><td>1.4</td></tr> <tr><td>150°</td><td>0.8</td><td>0.8</td><td>0.9</td><td>1.1</td><td>1.1</td><td>1.3</td><td>1.4</td></tr> <tr><td>180°</td><td>0.7</td><td>0.8</td><td>0.9</td><td>0.9</td><td>1.1</td><td>1.2</td><td>1.3</td></tr> </table>	MAXIMUM AXIAL DISTANCE FOR 110° SPRAY ANGLE IN METERS								FIXED ANGLE	K FACTOR (METRIC)								17.3	25.9	33.1	46.1	59.0	80.6	103.7	0°	3.4	3.4	3.4	3.4	3.4	3.4	3.4	30°	2.0	2.0	2.2	2.5	2.7	2.8	3.0	45°	1.7	1.8	2.0	2.1	2.3	2.4	2.6	60°	1.4	1.5	1.6	1.7	1.8	2.1	2.2	90°	1.2	1.2	1.4	1.5	1.7	1.8	2.0	120°	0.9	1.0	1.1	1.2	1.4	1.4	1.5	135°	0.8	0.8	1.0	1.1	1.3	1.4	1.4	150°	0.8	0.8	0.9	1.1	1.1	1.3	1.4	180°	0.7	0.8	0.9	0.9	1.1	1.2	1.3	<table border="1" style="width: 100%; border-collapse: collapse;"> <tr><th colspan="8">MAXIMUM AXIAL DISTANCE FOR 180° SPRAY ANGLE IN METERS</th></tr> <tr><th>FIXED ANGLE</th><th colspan="7">K FACTOR (METRIC)</th></tr> <tr><th></th><th>17.3</th><th>25.9</th><th>33.1</th><th>46.1</th><th>59.0</th><th>80.6</th><th>103.7</th></tr> <tr><td>0°</td><td>1.2</td><td>1.2</td><td>1.2</td><td>1.2</td><td>1.2</td><td>1.2</td><td>1.2</td></tr> <tr><td>30°</td><td>0.7</td><td>0.7</td><td>0.8</td><td>0.8</td><td>0.9</td><td>0.9</td><td>0.9</td></tr> <tr><td>45°</td><td>0.6</td><td>0.6</td><td>0.6</td><td>0.7</td><td>0.8</td><td>0.8</td><td>0.8</td></tr> <tr><td>60°</td><td>0.5</td><td>0.5</td><td>0.5</td><td>0.6</td><td>0.7</td><td>0.8</td><td>0.8</td></tr> <tr><td>90°</td><td>NR</td><td>NR</td><td>0.3</td><td>0.3</td><td>0.5</td><td>0.5</td><td>0.7</td></tr> <tr><td>120°</td><td>NR</td><td>NR</td><td>0.3</td><td>0.3</td><td>0.4</td><td>0.5</td><td>0.5</td></tr> <tr><td>135°</td><td>NR</td><td>NR</td><td>NR</td><td>0.3</td><td>0.3</td><td>0.4</td><td>0.5</td></tr> <tr><td>150°</td><td>NR</td><td>NR</td><td>NR</td><td>NR</td><td>0.3</td><td>0.4</td><td>0.4</td></tr> <tr><td>180°</td><td>NR</td><td>NR</td><td>NR</td><td>NR</td><td>NR</td><td>0.3</td><td>0.3</td></tr> </table>	MAXIMUM AXIAL DISTANCE FOR 180° SPRAY ANGLE IN METERS								FIXED ANGLE	K FACTOR (METRIC)								17.3	25.9	33.1	46.1	59.0	80.6	103.7	0°	1.2	1.2	1.2	1.2	1.2	1.2	1.2	30°	0.7	0.7	0.8	0.8	0.9	0.9	0.9	45°	0.6	0.6	0.6	0.7	0.8	0.8	0.8	60°	0.5	0.5	0.5	0.6	0.7	0.8	0.8	90°	NR	NR	0.3	0.3	0.5	0.5	0.7	120°	NR	NR	0.3	0.3	0.4	0.5	0.5	135°	NR	NR	NR	0.3	0.3	0.4	0.5	150°	NR	NR	NR	NR	0.3	0.4	0.4	180°	NR	NR	NR	NR	NR	0.3	0.3
MAXIMUM AXIAL DISTANCE FOR 110° SPRAY ANGLE IN METERS																																																																																																																																																																																																	
FIXED ANGLE	K FACTOR (METRIC)																																																																																																																																																																																																
	17.3	25.9	33.1	46.1	59.0	80.6	103.7																																																																																																																																																																																										
0°	3.4	3.4	3.4	3.4	3.4	3.4	3.4																																																																																																																																																																																										
30°	2.0	2.0	2.2	2.5	2.7	2.8	3.0																																																																																																																																																																																										
45°	1.7	1.8	2.0	2.1	2.3	2.4	2.6																																																																																																																																																																																										
60°	1.4	1.5	1.6	1.7	1.8	2.1	2.2																																																																																																																																																																																										
90°	1.2	1.2	1.4	1.5	1.7	1.8	2.0																																																																																																																																																																																										
120°	0.9	1.0	1.1	1.2	1.4	1.4	1.5																																																																																																																																																																																										
135°	0.8	0.8	1.0	1.1	1.3	1.4	1.4																																																																																																																																																																																										
150°	0.8	0.8	0.9	1.1	1.1	1.3	1.4																																																																																																																																																																																										
180°	0.7	0.8	0.9	0.9	1.1	1.2	1.3																																																																																																																																																																																										
MAXIMUM AXIAL DISTANCE FOR 180° SPRAY ANGLE IN METERS																																																																																																																																																																																																	
FIXED ANGLE	K FACTOR (METRIC)																																																																																																																																																																																																
	17.3	25.9	33.1	46.1	59.0	80.6	103.7																																																																																																																																																																																										
0°	1.2	1.2	1.2	1.2	1.2	1.2	1.2																																																																																																																																																																																										
30°	0.7	0.7	0.8	0.8	0.9	0.9	0.9																																																																																																																																																																																										
45°	0.6	0.6	0.6	0.7	0.8	0.8	0.8																																																																																																																																																																																										
60°	0.5	0.5	0.5	0.6	0.7	0.8	0.8																																																																																																																																																																																										
90°	NR	NR	0.3	0.3	0.5	0.5	0.7																																																																																																																																																																																										
120°	NR	NR	0.3	0.3	0.4	0.5	0.5																																																																																																																																																																																										
135°	NR	NR	NR	0.3	0.3	0.4	0.5																																																																																																																																																																																										
150°	NR	NR	NR	NR	0.3	0.4	0.4																																																																																																																																																																																										
180°	NR	NR	NR	NR	NR	0.3	0.3																																																																																																																																																																																										

NR = Not Recommended

**Figure 6b: Maximum Axial Distance Between Nozzle Tip and Plane of Protection for Exposure Protection (m)**

**NOTES ABOUT FIGURES 6a AND 6b:**

- Working pressures of 10 to 60 PSI (.7 to 4.1 Bar) can only be applied for 0° (vertically downward) orientation.
- Working pressures for orientation angles other than 0° are 20 to 60 PSI (1.4 to 4.1 Bar).
- However, unless otherwise specified, when the nozzles are axially installed 2 ft. (.6 m) or less from the plane of protection, working pressures of 10 to 60 PSI (.7 to 4.1 Bar) can be applied on all installation angles.

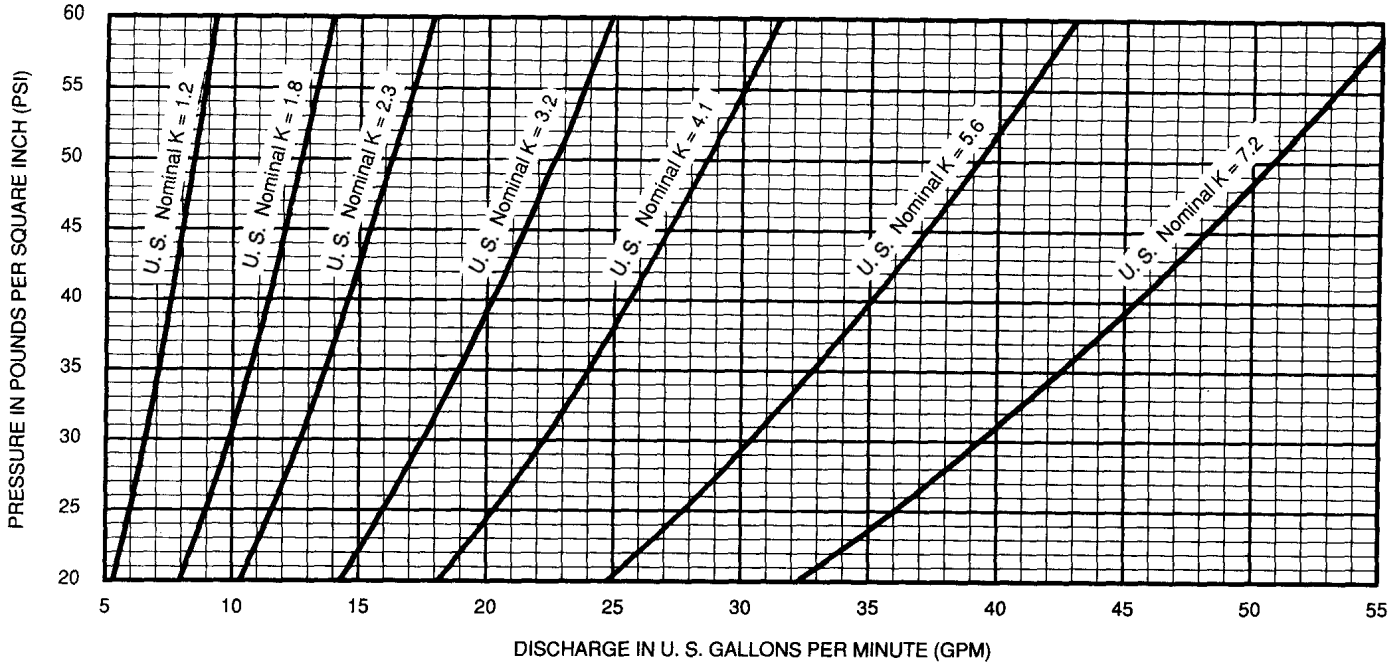


TECHNICAL DATA

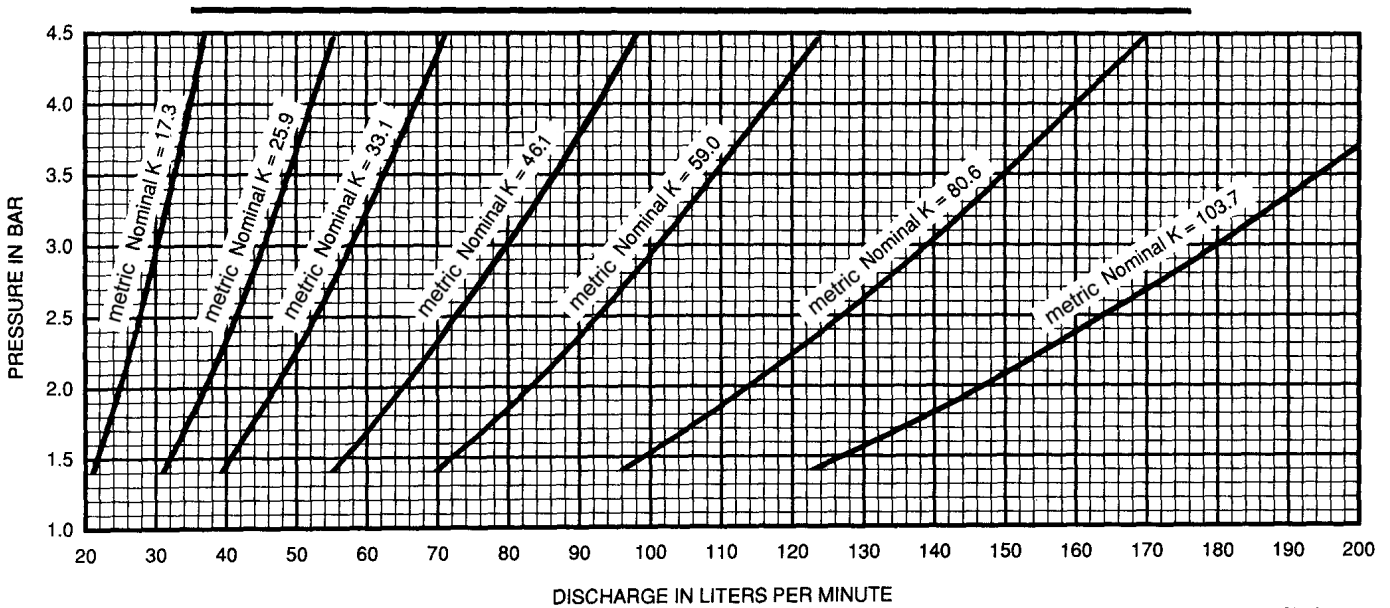
MODEL E SPRAY NOZZLES  
VK810 - VK817

The Viking Corporation, 210 N Industrial Park Drive, Hastings MI 49058

Telephone: 269-945-9501 Technical Services: 877-384-5464 Fax: 269-818-1680 Email: techsvcs@vikingcorp.com



**NOTE:**  $Q = K\sqrt{p}$ ; where "Q" = flow in U.S. gallons per minute, "p" = pressure in pounds per square inch, and "K" is the nominal discharge coefficient.



**NOTE:**  $Q = K\sqrt{p}$ ; where "Q" = flow in liters per minute, "p" = pressure in bar, and "K" is the nominal discharge coefficient.

**Figure 7: Nominal Discharge Curves**  
(Refer to the Authority Having Jurisdiction for Their Minimum Required Residual Pressure.)

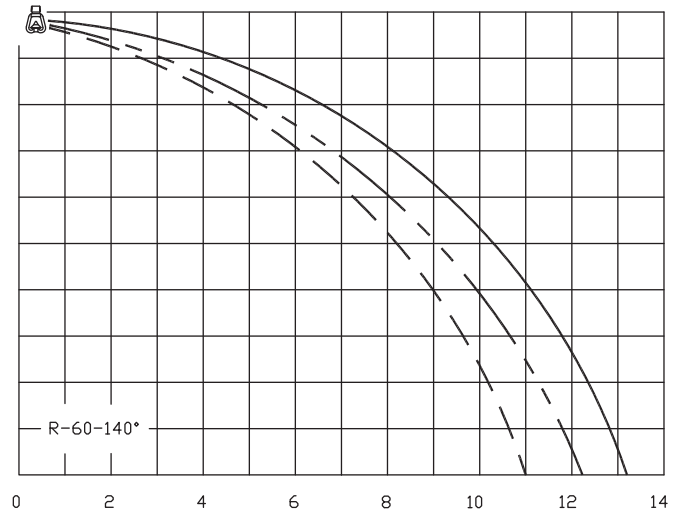
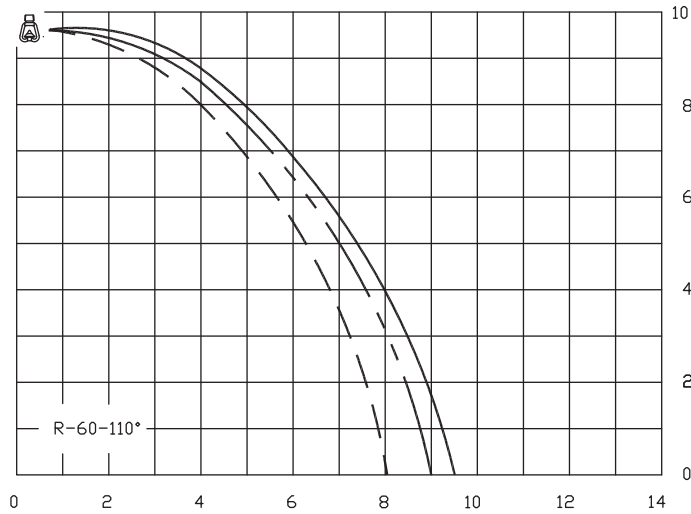
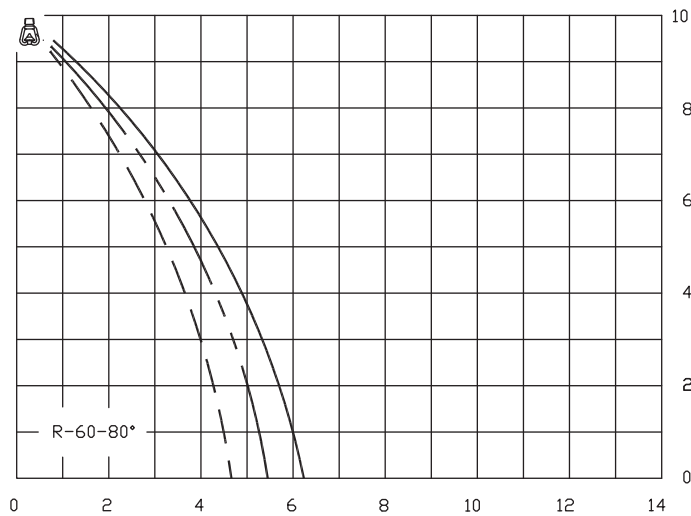
## Distribution Patterns

### Model A Spray Nozzle, K = 5.80, .453" Orifice

1. Profile indicates maximum effective throw of one half of symmetrical spray pattern.
2. Sprinklers shown operating at flowing pressures indicated.
3. Spacings = one foot.
4. Legend:

7 P.S.I. -----  
 15 P.S.I. - - - - -  
 30 P.S.I. - - - - -

These distribution patterns illustrate approximate trajectory and coverage as guidance for preventing an obstruction from being placed in the flow path. No specific coverage areas or densities are implied by these patterns.



# Electric solenoid valves.com

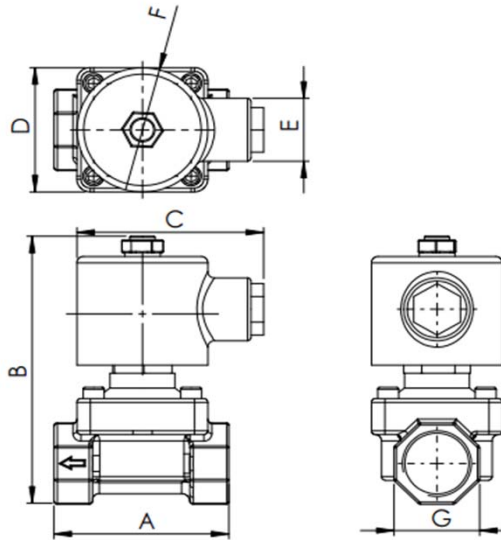


The Brass - Series Semi-Direct acting, 2 Way General Purpose Solenoid Valves provide on-off control of inert liquids and gases. Suitable for commercial and residential applications. This valve type is gravity feed capable and is ideal for low pressure fluid applications. Available in sizes from 3/8" - 2" in both Normally Closed and Normally Open operating positions.

\*These valves are not intended for use in medical life support, combustion, aviation, aerospace, automotive or similar applications.

Materials	
Valve Body	Brass
Seal	FKM
Shading Ring	Copper
Hardware	S/S

Electrical				
Connection Type	N/C - 5.5" Lead		N/O - DIN	
Protection Class	NEMA 3		IP54	
Available Voltages	DC: 24V	DC: 12V	AC: 24V/60Hz	AC: 110V/60Hz
Power 3/8" - 1"	28 W	18 W	28 W	28 W
Power 1-1/4" - 2"	40 W	30 W	40 W	40 W

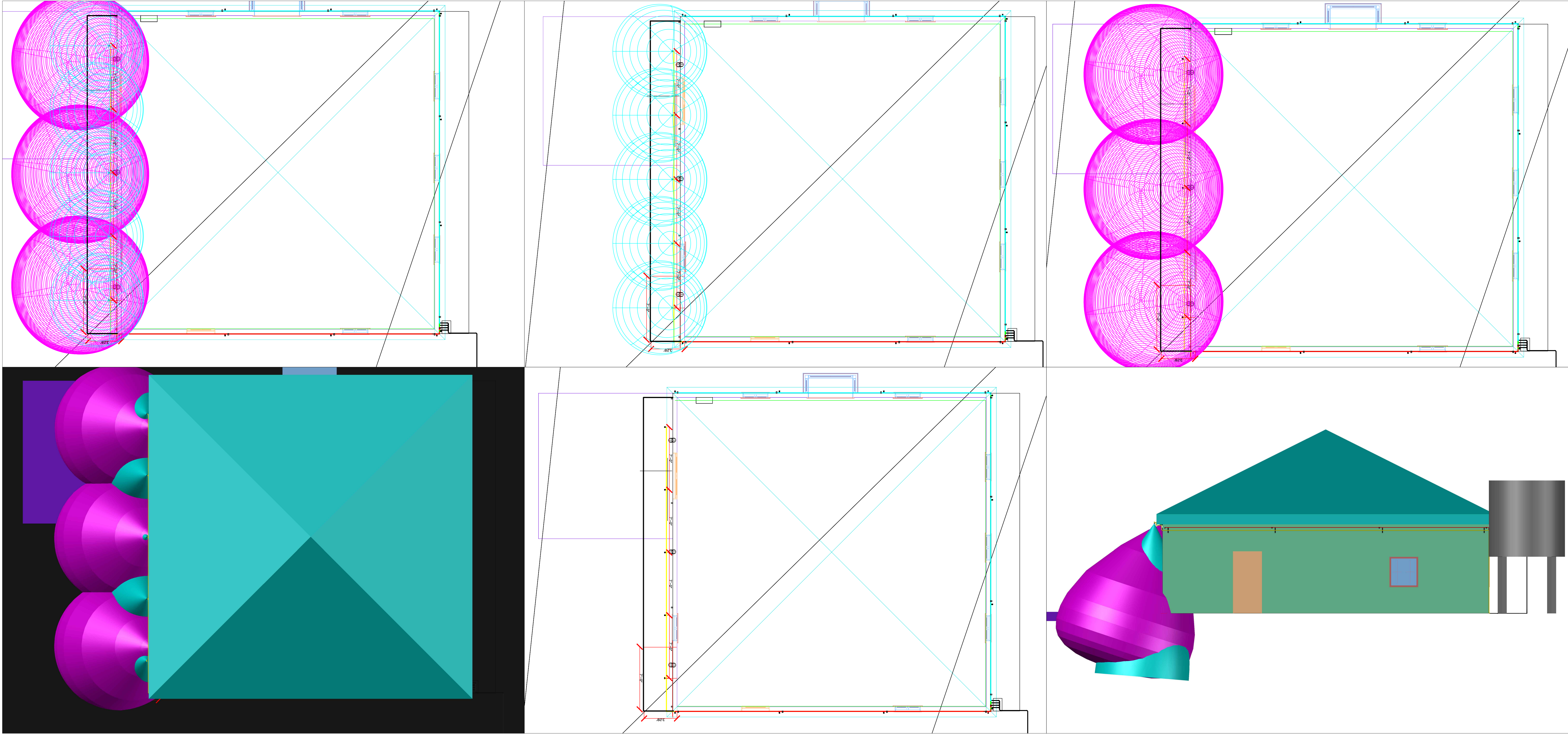


Brass - Series						Operating Temp		Dimensions								
Port Size	Thread	Orifice	Cv Value	Min PSI	Max PSI	Min	Max	Duty Cycle	Weight	A	B	C	D	E	F	G
Normally Closed																
3/8"	NPT	5/8	4.8	0	AC145 DC115	15°F	250°F	100%	1lb 7oz	2.36"	4.00"	2.83"	2.00"	1.00"	1.96"	1.05"
1/2"	NPT	5/8	4.8	0	AC145 DC115	15°F	250°F	100%	1lb 7oz	2.36"	4.00"	2.83"	2.00"	1.00"	1.96"	1.06"
3/4"	NPT	3/4	7.6	0	AC145 DC115	15°F	250°F	100%	1lb 10oz	2.65"	4.25"	2.83"	2.00"	1.00"	1.96"	1.30"
1"	NPT	1	12	0	AC145 DC115	15°F	250°F	100%	2lb 5oz	3.25"	4.50"	2.83"	2.60"	1.00"	1.96"	1.57"
1-1/4"	NPT	1 1/4	24	0	AC145 DC90	15°F	250°F	100%	4lbs 11oz	4.00"	5.80"	3.55"	3.22"	1.00"	2.70"	1.95"
1-1/2"	NPT	1 4/7	29	0	AC145 DC90	15°F	250°F	100%	4lbs 14oz	4.33"	6.00"	3.55"	3.35"	1.00"	2.70"	2.20"
2"	NPT	1 7/8	48	0	AC145 DC90	15°F	250°F	100%	7lbs	5.30"	6.50"	3.55"	4.25"	1.00"	2.70"	2.66"
Normally Open																
1/2"	NPT	5/8	4.8	0	90	15°F	250°F	100%	1lb 9oz	2.36"	4.50"	3.50"	1.95"	.80"	1.96"	1.06"
3/4"	NPT	3/4	7.6	0	90	15°F	250°F	100%	1lb 13oz	2.65"	4.70"	3.50"	2.00"	.80"	1.96"	1.30"
1"	NPT	1	12	0	90	15°F	250°F	100%	2lb 7oz	3.20"	5.00"	3.50"	2.60"	.80"	1.96"	1.57"
1-1/2"	NPT	1 4/7	29	0	90	15°F	250°F	100%	5lb 2oz	4.33"	7.00"	4.50"	3.25"	1.15"	2.75"	2.25"
2"	NPT	1 7/8	48	0	90	15°F	250°F	100%	7lb 8oz	5.30"	7.50"	4.50"	4.25"	1.15"	2.75"	2.75"

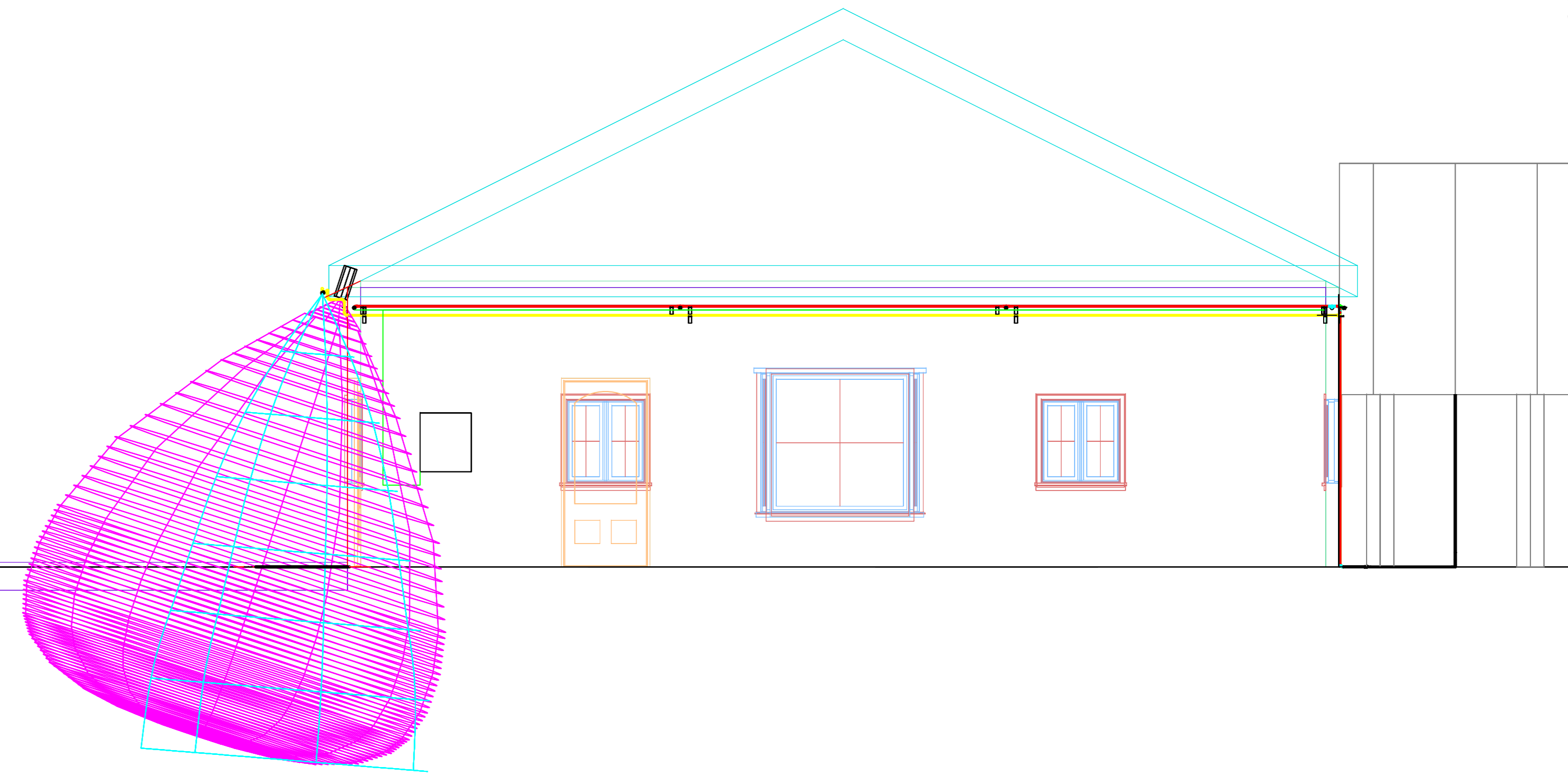
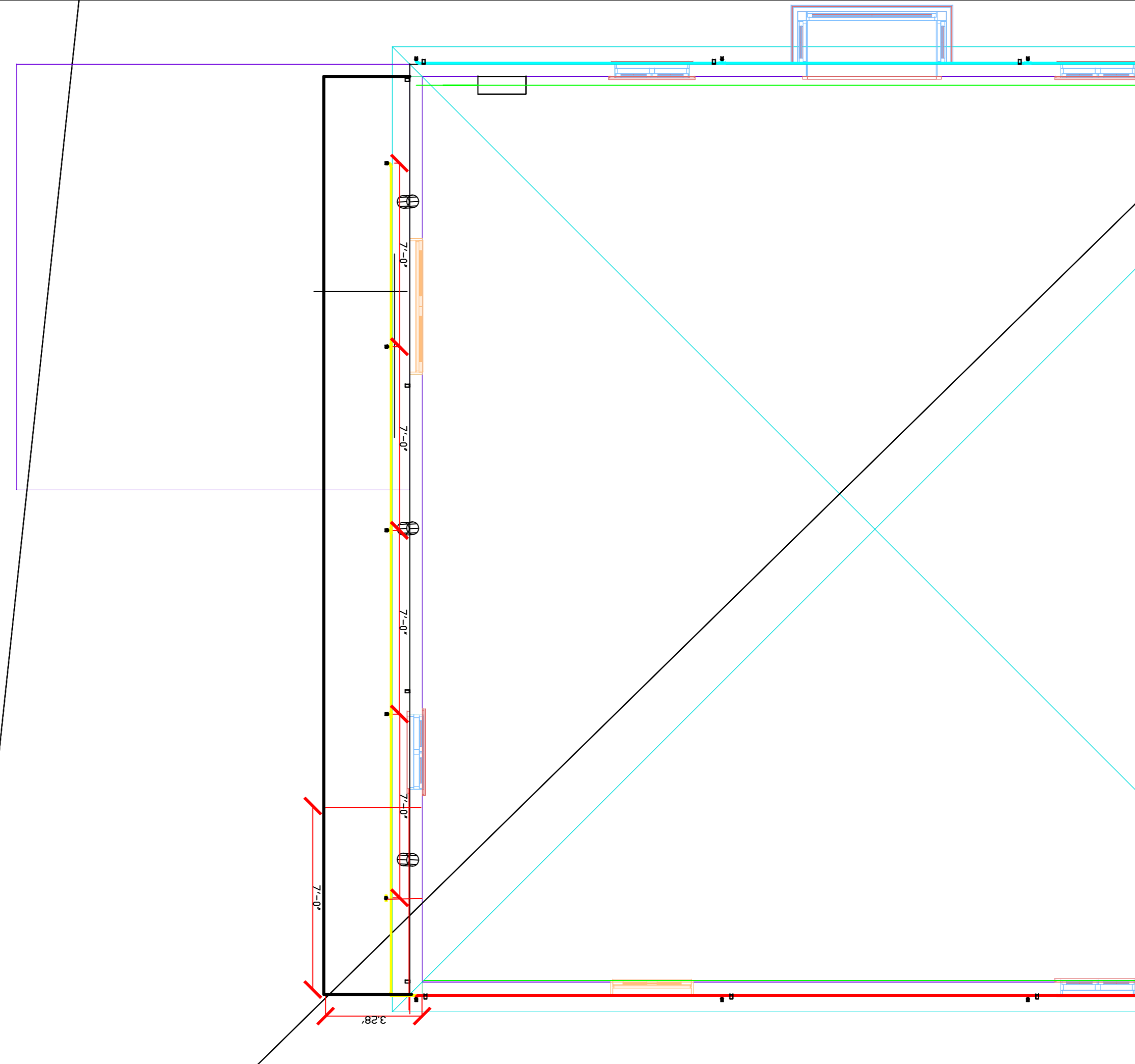
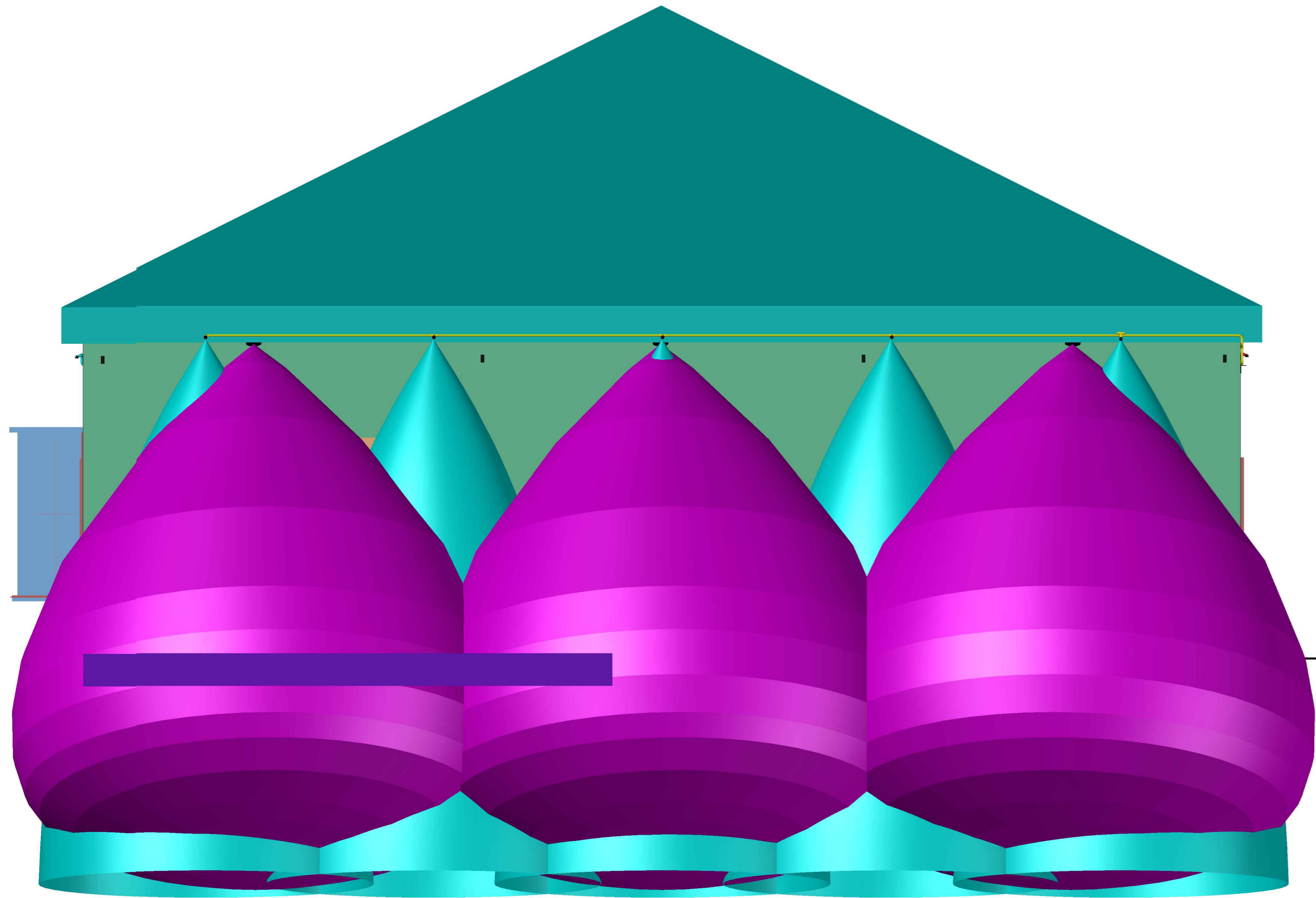
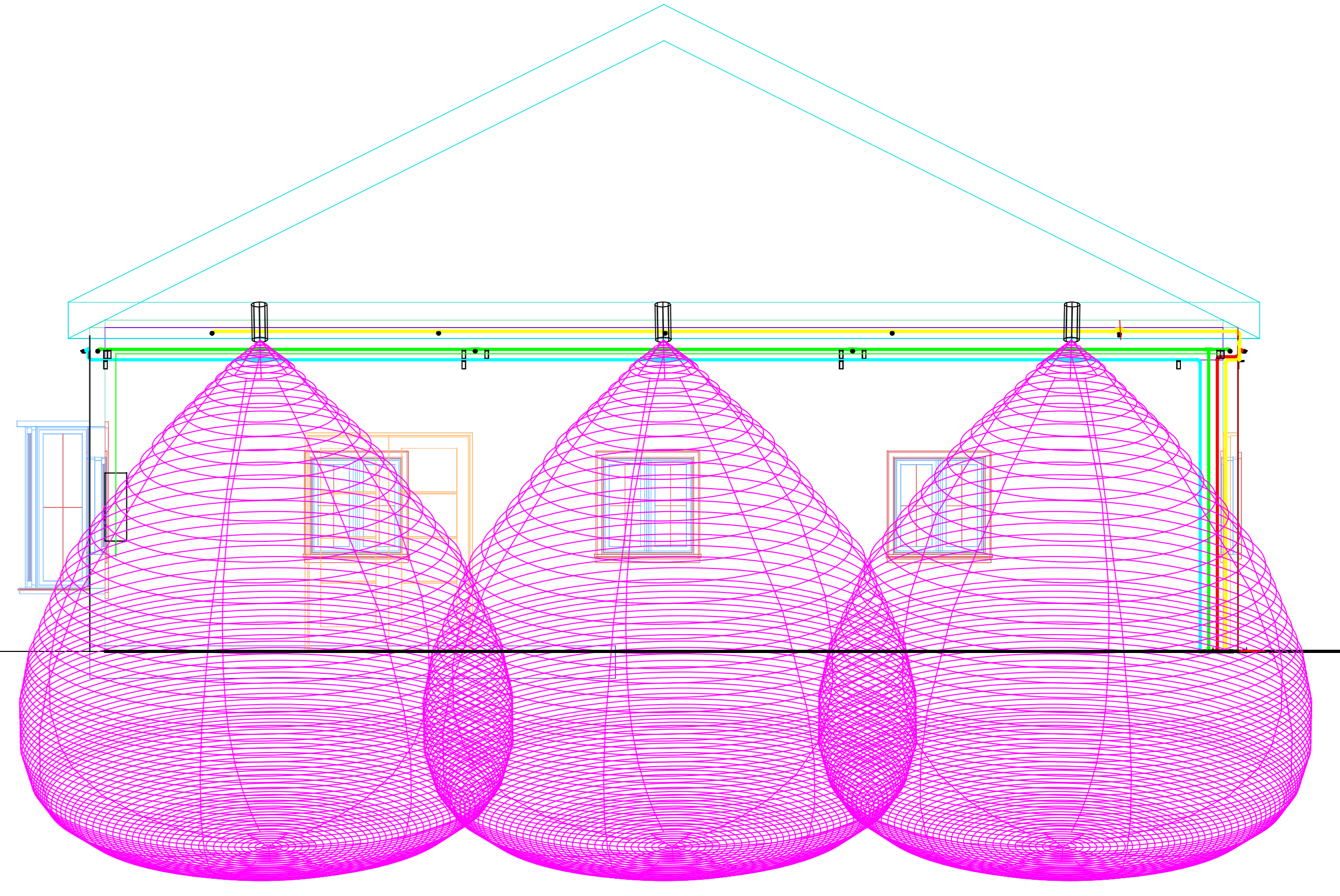
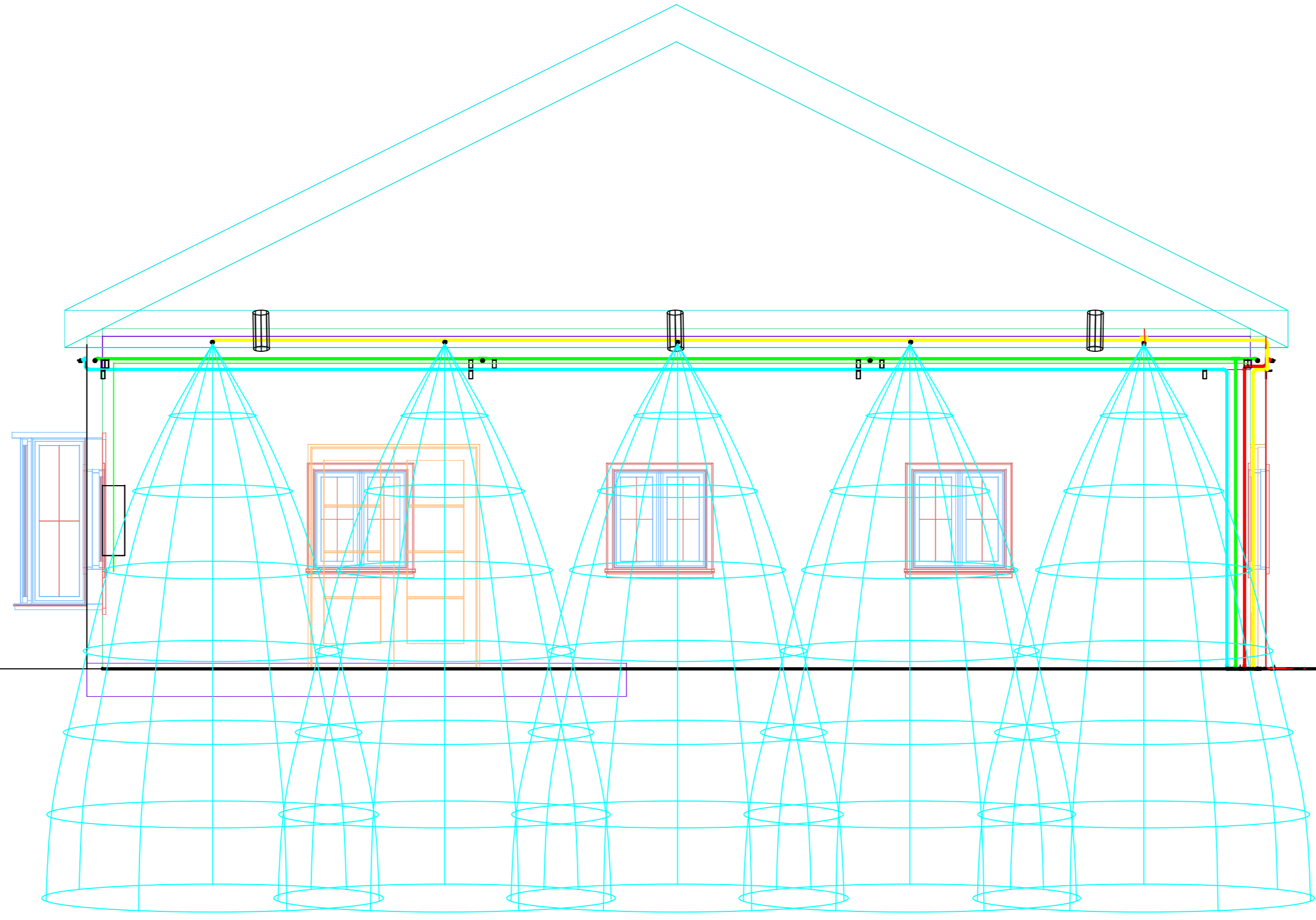
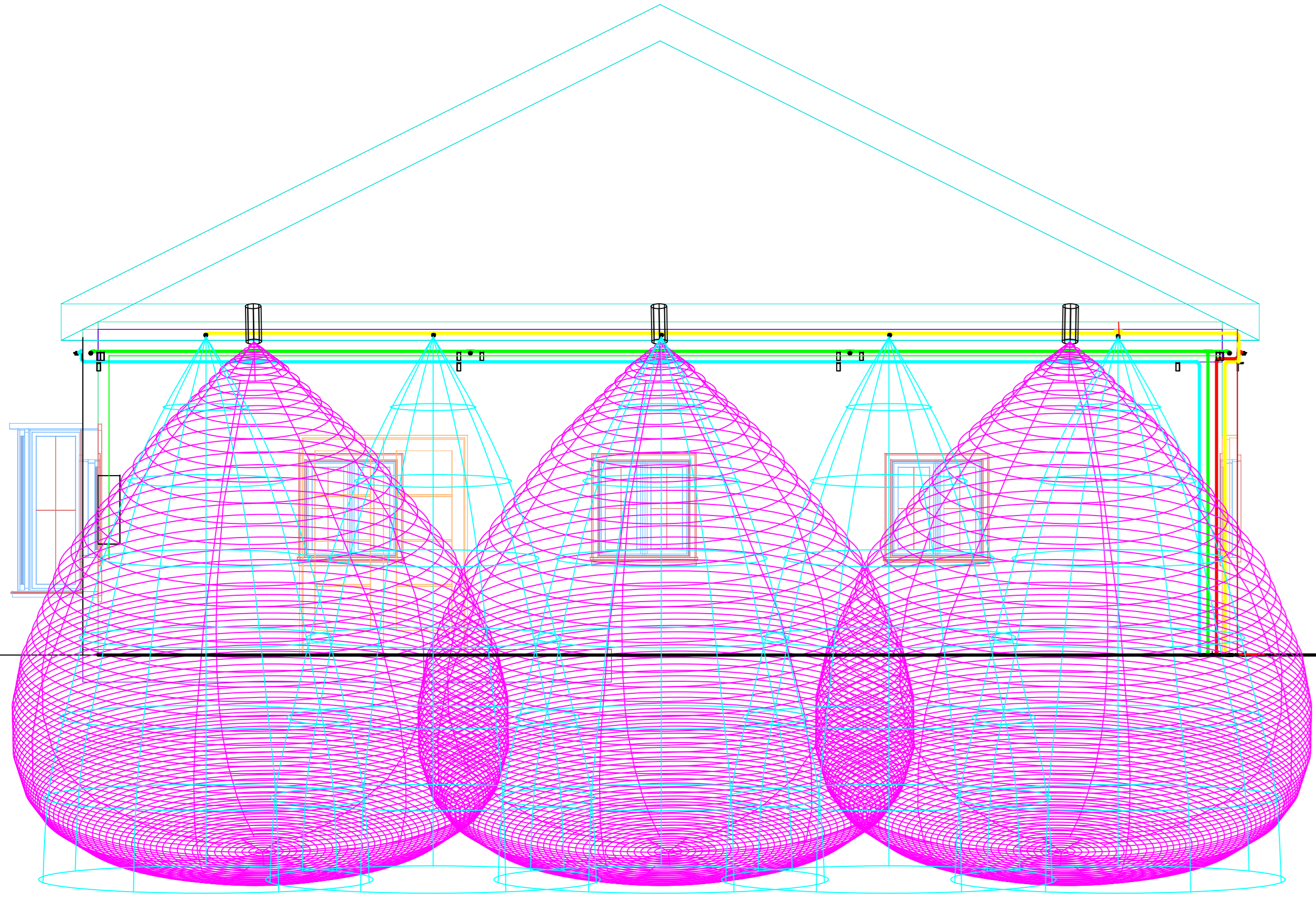
\*Consult a chemical compatibility expert for correct seal and valve body material choice.

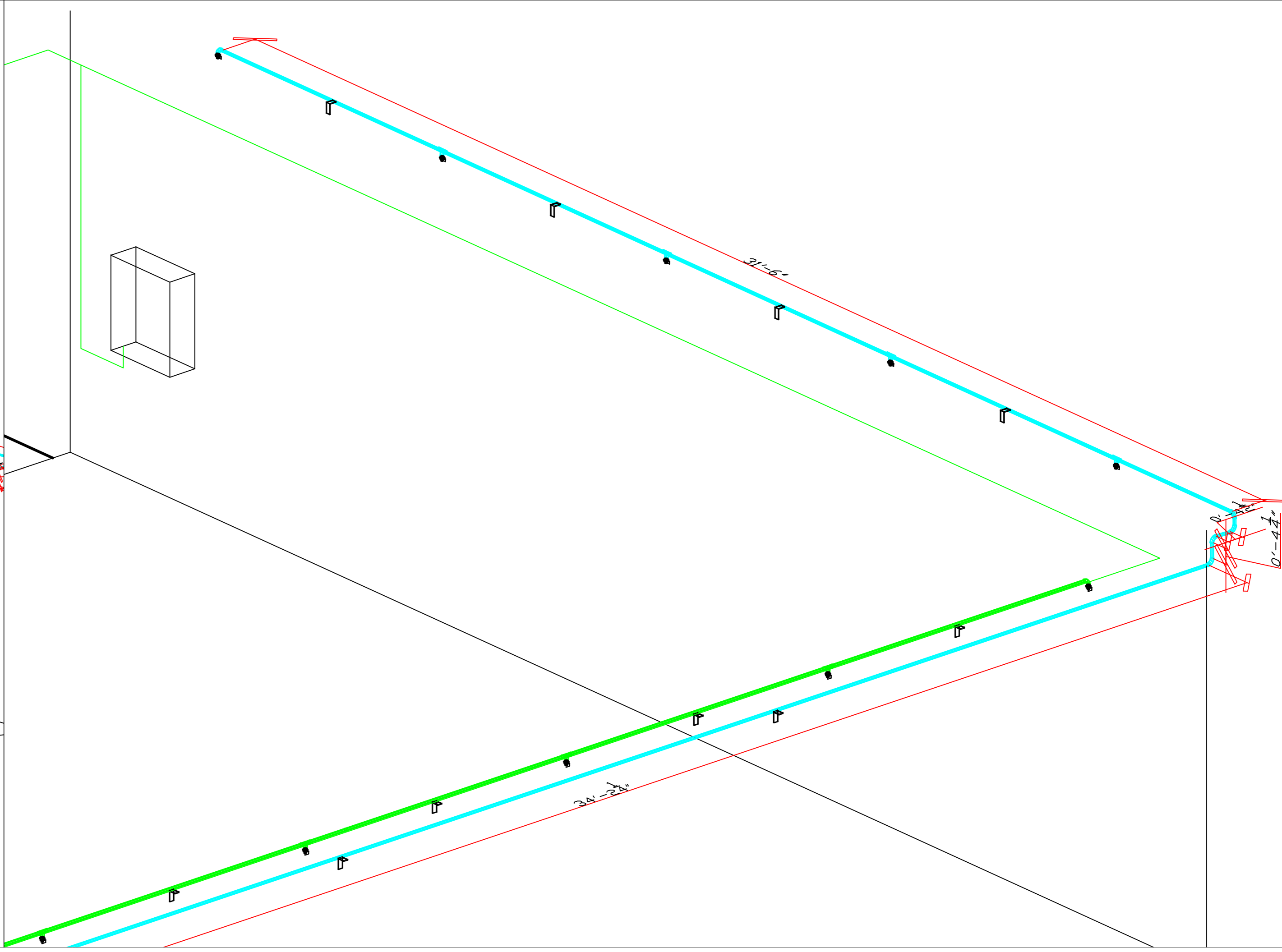
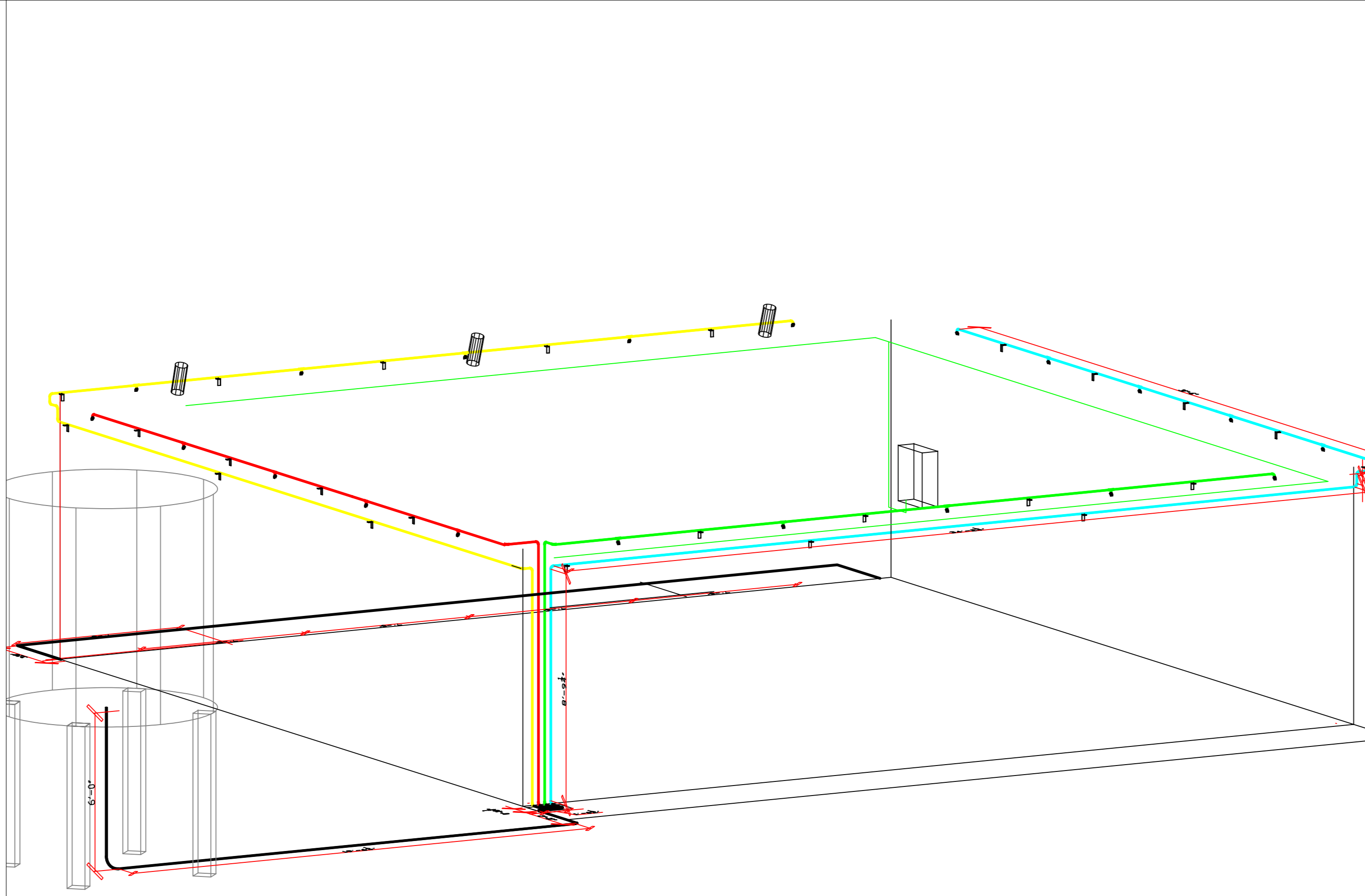
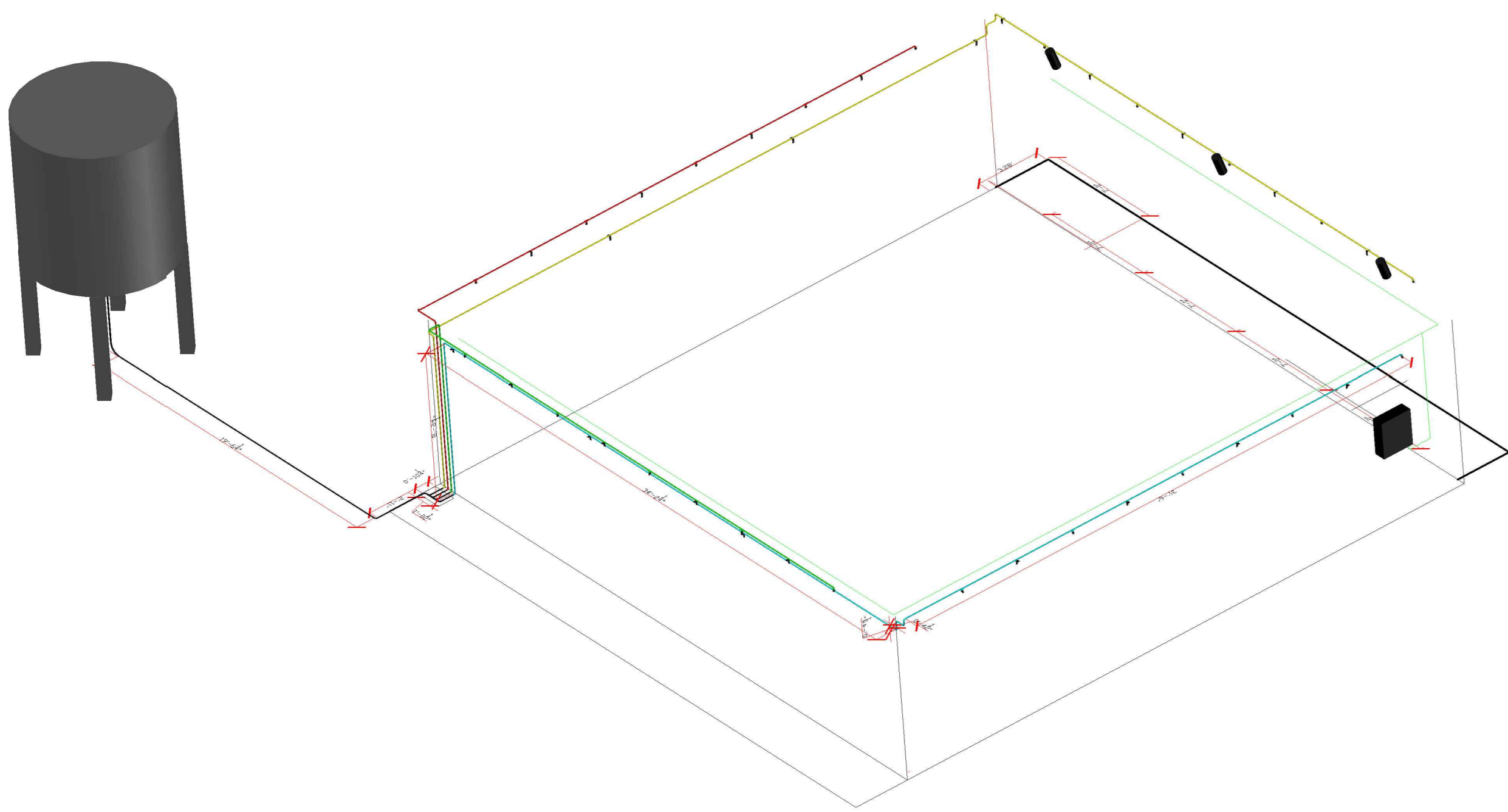
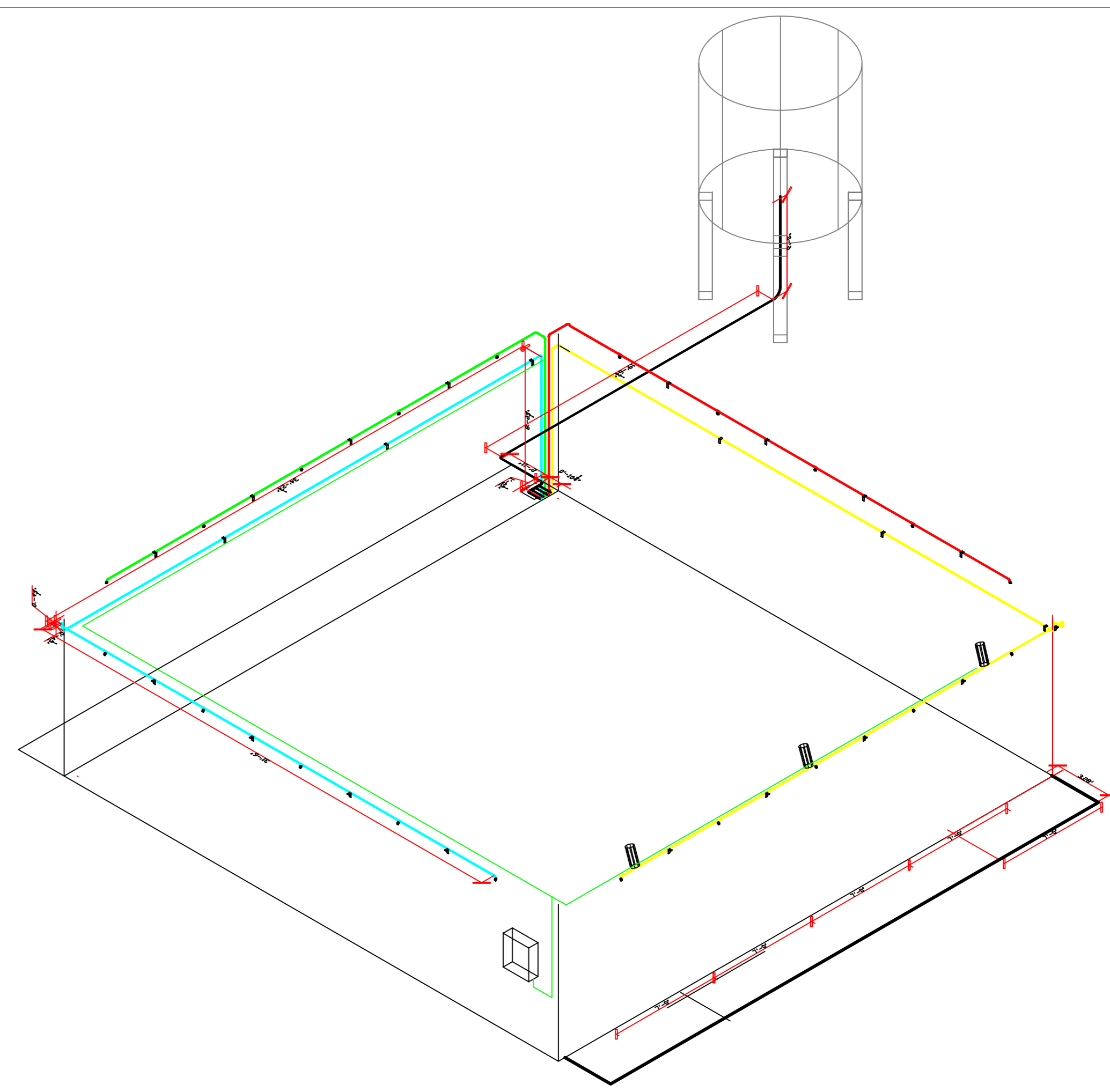
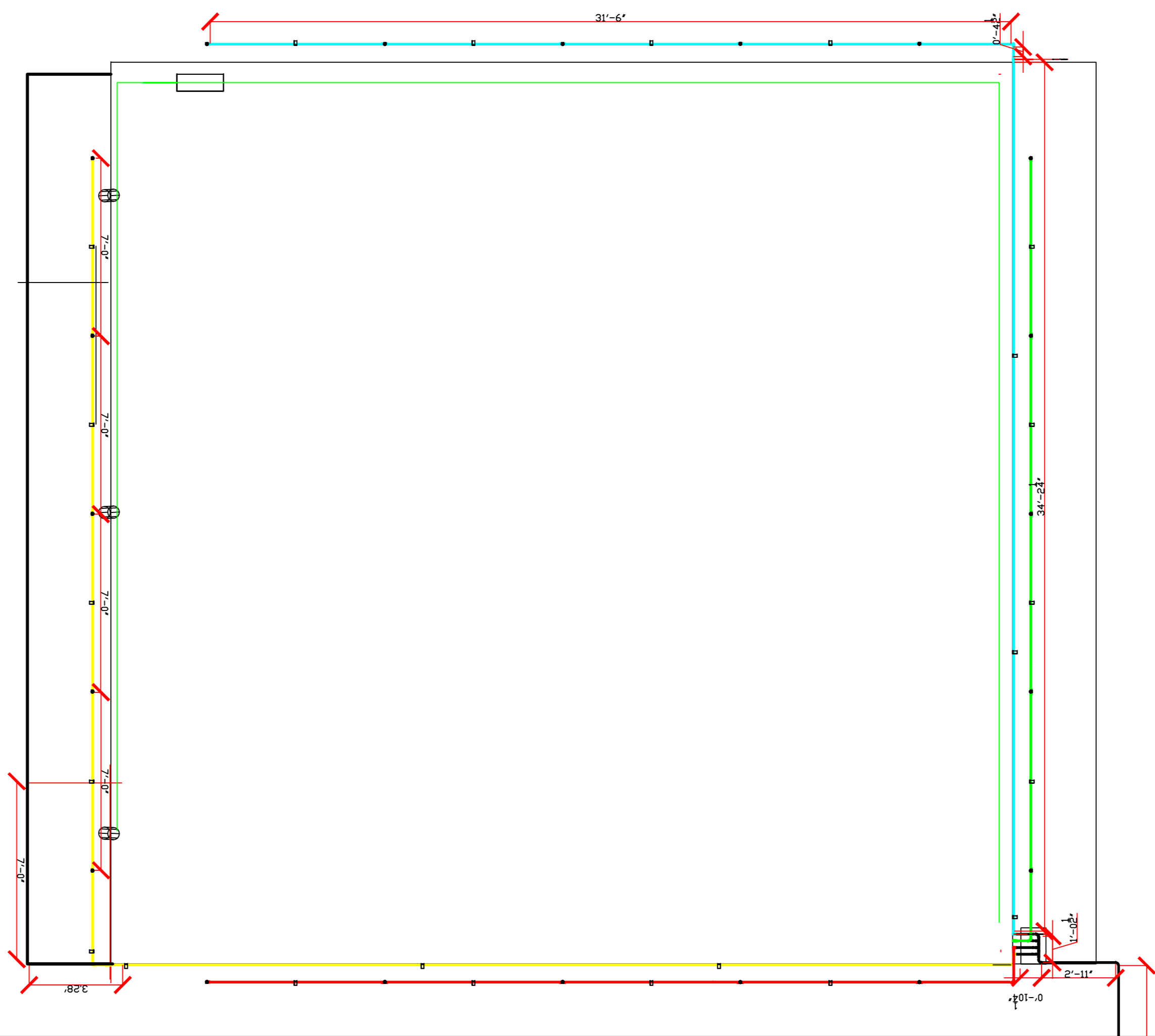
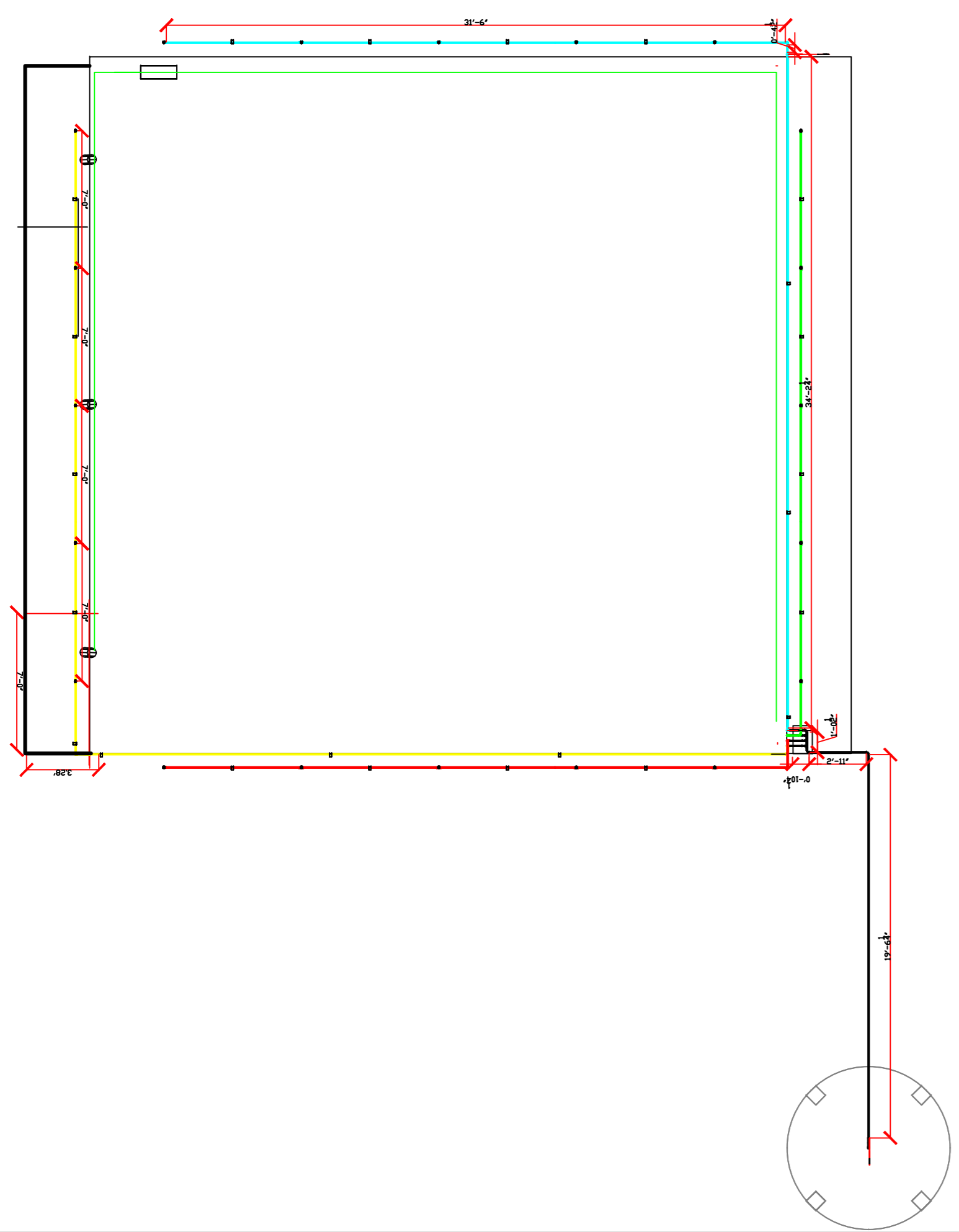
\*Weight and dimensions may vary slightly from production.

## Appendix D: System Design and Hydraulic Calculations









VIKING

1-2.		q Q		1	1E	Lgth. 7 Ftg. 2 Tot. 9	0.074	Pt Pe 0.0 Pf	31.95 0.00 0.67	Pt Pv Pn	C Pt 31.95 K1 2.30
2		q Q	13.13			Lgth. Ftg. Tot.		Pt Pe Pf	32.61	Pt Pv Pn	
2-3		q Q	26.13 26.13	1	1T	Lgth. 7 Ftg. 5 Tot. 12	0.269	Pt Pe 0.0 Pf	32.61 0.00 3.23	Pt 35.85 Pv 0.767044 Pn 35.08	
3		q Q	13.77			Lgth. Ftg. Tot.		Pt Pe Pf	35.85	Pt Pv Pn	
3-4		q Q	39.91 39.91	1.25	1T	Lgth. 7 Ftg. 6 Tot. 13	0.199	Pt Pe 0.0 Pf	35.85 0.00 2.59	Pt 38.43 Pv 0.732497 Pn 37.70	
4		q Q	14.26			Lgth. Ftg. Tot.		Pt Pe Pf	38.43	Pt Pv Pn	
4-5		q Q	54.16 54.16	1.25	1T	Lgth. 7 Ftg. 6 Tot. 13	0.350	Pt Pe 0.0 Pf	38.43 0.00 4.55	Pt 42.98 Pv 1.349471 Pn 41.63	
5		q Q	15.08			Lgth. Ftg. Tot.		Pt Pe Pf	42.98	Pt Pv Pn	
5-Tank		q Q	69.24 69.24	2	10E 3T	Lgth. 69.49 Ftg. 40.8 Tot. 110.29	0.056	Pt Pe 3.2 Pf	42.98 1.39 6.16	Pt 50.54 Pv 0.336523 Pn 50.20	
Total		Q	69.24	Safety factor to use in other adtional devices				20.0	50.54 P 70.54		

Reliable

1-2.		q Q		1	1E	Lgth. 8.75 Ftg. 2 Tot. 10.75	0.327	Pt Pe 0.0 Pf	25.00 0.00 3.51	Pt Pv Pn	C Pt 25.00 K1 5.80
2		q Q	30.97			Lgth. Ftg. Tot.		Pt Pe Pf	28.51	Pt Pv Pn	
2-3		q Q	59.97 59.97	1	1T	Lgth. 8.75 Ftg. 5 Tot. 13.75	1.253	Pt Pe 0.0 Pf	28.51 0.00 17.22	Pt 45.74 Pv 4.038731 Pn 41.70	
3		q Q	39.22			Lgth. Ftg. Tot.		Pt Pe Pf	45.74	Pt Pv Pn	
3-4		q Q	99.19 99.19	1.25	1T	Lgth. 8.75 Ftg. 6 Tot. 14.75	1.072	Pt Pe 0.0 Pf	45.74 0.00 15.81	Pt 61.55 Pv 4.52596 Pn 57.02	
4		q Q	45.50			Lgth. Ftg. Tot.		Pt Pe Pf	61.55	Pt Pv Pn	
4-Tank		q Q	144.70 144.70	2	10E 3T 1T	Lgth. 69.49 Ftg. 50.8 Tot. 120.29	0.219	Pt Pe 3.2 Pf	61.55 1.39 26.29	Pt 89.23 Pv 1.469518 Pn 87.76	
Total		Q	144.70	Safety factor to use in other adtional devices				20.0	89.23 P 109.23		

## Appendix E: Project Methodology

