

An Energy Analysis of the Foisie Innovation Studio

A Major Qualifying Project Submitted to the Faculty of **Worcester Polytechnic Institute** In partial fulfillment of the requirements for the Degree of Bachelor of Science In Civil Engineering

Submitted on March 24, 2015 by:



Zachary Blanchard

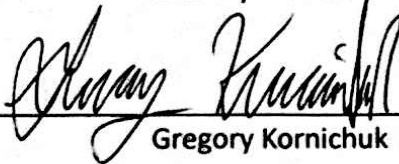

Gregory Kornichuk



Taylor Landry



John McGonagle

Project Advisors:

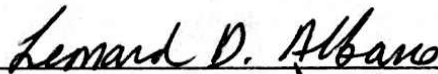

Professor Leonard Albano



Professor Guillermo Salazar

"This report is the product of an education program, and is intended to serve as partial documentation for the evaluation of academic achievement. The report should not be construed as a working document by the reader."

Abstract

This project analyzed the energy efficiency of Alumni Gym's building enclosure under the existing conditions and proposed renovations. Thermal imaging and Building Information Modeling were utilized to support this study. Recommendations for additional improvements were formulated based on the analysis of the proposed renovations. Proposed improvements included modifications to insulation, windows, the roof structure, the North Entry, and the addition of solar panels. A life-cycle cost assessment was conducted for each proposed change in order to determine its long term economic feasibility.

Acknowledgements

We would like to thank the following people for their contributions to our project:

- Our advisors, Professor Leonard Albano and Professor Guillermo Salazar for providing guidance and direction throughout the entirety of the project;
- Professor Kenneth Elovitz who provided guidance that helped us complete our conduction and infiltration calculations;
- Theresa Mailloux who allowed us access into Alumni Gym to gather valuable information;
- Lieutenant Michael Ellsworth for putting us in contact with WPI facilities;
- Jeff Lussier for providing us with initial information on the current renovation project;
- Stephen Feige of Goody Clancy & Associates of Boston for sending us necessary information to further our project.

Authorship

Throughout research, design and analysis, and writing this report, the team members provided equal contributions in research and writing. Thus, all team members claim equal credit as authors. Details regarding the specific contributions of each student during this Major Qualifying Project (MQP) follow.

Zachary Blanchard focused on the “Capstone Design Statement,” Chapter Two, and Chapter Four.

Greg Kornichuk focused on the “Design Problem,” Chapter One, Chapter Two, Chapter Four, Chapter Five, and Chapter Six.

Taylor Landry concentrated on the “Professional Licensure,” Chapter Two, Chapter Three, and Chapter Seven.

John McGonagle contributed on Chapter Two, Chapter Three, Chapter Five, Chapter Six, and Chapter Eight.

Although sections of the report have primary authors, each section underwent multiple team edits. Our team worked together in an equitable and cooperative manner to produce the final product.

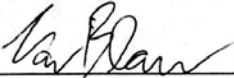

Zachary Blanchard



Gregory Kornichuk

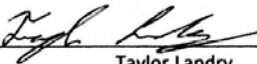

Taylor Landry

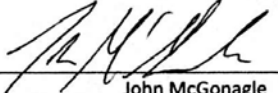

John McGonagle

Capstone Design Statement

This Major Qualifying Project (MQP) had an integrated capstone design experience. Below is a discussion of the design problem of the project, the approach to the design problem, and how the ABET General Criterion Eight Realistic Constraints were addressed.

Design Problem

The need and desire for green construction continues to grow with the world's increased focus on the environment and sustainability. A major part of green construction is the design and building of a facility that is as energy efficient as possible. As a result, many developers and clients want their projects to be certified sustainable with a large focus on thermal efficiency. In the U.S., residential and commercial buildings account for 40% of total energy consumption. A major portion of this energy consumption in buildings, roughly 48%, is for their heating and cooling (U.S. Department of Energy, 2014). In March 2000, the U.S. Green Building Council unveiled the LEED (Leadership in Energy and Environmental Design) green building certification system, a system certifying commercial, institutional, and residential buildings for their exceptional environmental and health performance. By 2011, there were a total of 10,000 commercial LEED certified buildings. The five major criteria for certification are: sustainable sites, water efficiency, energy and atmosphere, materials and resources, and indoor environmental quality (LEED Certification Information, 2014).

Worcester Polytechnic Institute is no exception in striving towards sustainability when renovating and constructing new buildings on its 150-year-old campus. The four

most recent buildings that have been constructed have all been certified sustainable, achieving different levels of LEED Certification. The latest project occurring on WPI's campus is the renovation of Alumni Gym, which will create a new space for student collaboration on group projects and showcase previous WPI innovations and achievements. While this renovation may not be submitted for LEED certification, there is potential for the design, construction process, and the building operations to align with WPI's values of energy efficiency and environmental sustainability.

Scope of Work

This project used Building Information Modeling (BIM), thermal imaging, and conduction and infiltration calculations to analyze the building's thermal heating performance and provide recommendations for potential improvements. Three different stages were investigated: the thermal performance of the existing building (Phase 1) which was used as a benchmark, the expected thermal performance based on the current design for the renovation (Phase 2), and potential thermal performance of multiple alternative designs based on the results of the previous two analyses (Phase 3). Areas of significant thermal losses in the existing building were identified and any possible improvements were tested using hand calculations. Installations of renewable energy solutions, such as solar panels, were also investigated to reduce the overall environmental impact of the new renovation. The proposed installation of solar panels warranted a structural analysis of the roof system to ensure the structural integrity of the facility is maintained. All of the alternatives were analyzed for performance, constructability, and monetary costs.

In order to investigate the three different stages stated above, BIM models reflecting the building's thermal performance were created at different phases to compare performance and to note any improvements to the thermal performance of the building's enclosure. First, a BIM model of the existing Alumni Gym was created and used to analyze the current thermal performance. Next, a second model was created using the current construction documents as designed by Goody Clancy & Associates of Boston to reflect the building's predicted performance. Ideally, simulations of these models were going to be run through *Green Building Studio* and a life-cycle cost would be generated. However, problems with the phase two model meant that calculations had to be completed to assess the proposed design's thermal performance and environmental efficiency. For each phase, the conduction and infiltration was calculated and compared to the other phases of the project. These comparisons looked into the change in performance versus changes in cost of material and installation.

Approach

To assess the thermal efficiency of the building's envelope, an updated BIM model was created to depict Alumni Gym at its current state. To do this, a three dimensional (3D) model from a previous MQP group (Rubino, 2014) was reviewed, and an interior fit out was completed in order to make sure the model conformed to the current interior and exterior construction of Alumni Gym. The model that was available to the group reflected the envelope of the building, the existing structural components, and some additional components that were suggested by the previous MQP, but it did not include any details for interior members, rooms, etc. Material types, correct thicknesses, and

various irregularities were coupled with old building blueprints to completely update the 3D model to reflect the current state of Alumni Gym. Thermal imaging cameras were used to pinpoint air gaps and deterioration in the actual building's envelope. Had areas been found with discontinuities, their thermal properties would have been adjusted in the BIM model to more accurately reflect the current state of the building. However, none were found. Once completely updated, hand calculations were used to calculate the heat losses due to conduction and infiltration. Data from these calculations were used to conduct a thermal efficiency simulation.

After the hand calculations were completed, the economic performance was investigated through a life-cycle cost analysis to give the team a monetary benchmark of the performance of the building. The 3D model was then updated to fully reflect the proposed construction plans to determine the thermal efficiency of the building after the planned renovation. Again, hand calculations were conducted using the thermal information of the envelope assemblies obtained from the updated BIM model in *Green Building Studio*. With the information from the hand calculations, another life-cycle cost assessment was completed, reflecting the proposed construction plans. These results were compared to the benchmark performance and a percentage change was calculated.

After the hand calculations using the second model and the comparison life-cycle costs were completed, possible improvements to the thermal efficiency of the enclosure were designed. Changes to the enclosure, which included the alteration to the north entrance of the building, new windows, and modifications to the roof, were the main focus of possible design improvements. Next, hand calculations were completed to asses

the thermal performance of the proposed improvements. A life-cycle cost assessment was completed for each separate change, and a cost-benefit analysis was used to evaluate the overall improvement of the recommendation.

To evaluate the feasibility of installing solar panels on the roof of the building, a structural analysis of the roof trusses and supports was completed. The added loads on the roof as a result of the panels were investigated to assure no changes would need to be made to the existing structure. The connections of the panels to the roof were also analyzed to account for uplift and lateral forces acting on the panels. Once this analysis was completed, a cost-benefit analysis was performed to calculate the possible return on investment the panels could have from producing renewable energy.

Realistic Constraints

There are eight ABET General Criterion Realistic Constraints, several of which should be addressed in completing a Major Qualifying Project. This MQP addressed four of these constraints, which include: economic, environmental/sustainability, ethical, and health and safety.

Economic

The cost of a construction project is usually a major constraint for all involved in the design, construction, and completion. Estimates and budgets aim to keep the cost of projects in check. Renovations can be especially difficult due to the uncertainty and unknown factors that might exist in the old building. These costs were closely considered when making recommendations due to the budget set aside by WPI for this project.

The cost estimates relied heavily on hand calculations done based on the models, data from R.S. Means, and discussions with industry professions; all of which were aspects that were taken into account and modified using engineering judgment. Determining which solutions have the higher benefit-to-cost ratio depended on the performance increases shown by the hand calculations. These calculations took certain assumptions into account and did not guarantee to exactly reflect the real conditions.

Environmental/Sustainability

WPI has recently made a movement towards constructing buildings in a more environmentally friendly and energy efficient way (Worcester Polytechnic Institute, 2012). The focus of this project is rooted in trying to create a more sustainable and energy efficient building. The project focused on the thermal heating performance of the new renovation, and analyzed possible solutions that could help decrease the buildings environmental footprint.

Major changes in the new design were analyzed for environmental impact and thermal efficiency. Also, a thermal analysis was completed on the building to determine problem areas that could potentially be altered to reduce the environmental footprint. The feasibility of installing solar panels on the roof was also investigated to help further building envelope performance.

Ethical

With any project, there will be associated ethical constraints. This project specifically dealt with issues of data confidentiality. During the beginning stages of the

project, a confidentiality agreement was signed by the students to ensure that information regarding the plans of the building and past information was kept confidential. Another ethical constraint that came into play is the obligation of an engineer to fully disclose all findings and possible problems in their analysis. When the structural analysis of the roof was conducted, it was essential to ensure that the results were accurate and the appropriate building codes were upheld to help protect the general public. Any results that suggested the structure was unsafe or in violation of the building code would have required disclosure of these issues.

Health & Safety

ASCE Canon 1 states: Engineers shall hold paramount safety, health and welfare of the public and shall strive to comply with the principles of sustainable development in the performance of their professional duties (ASCE, 2014). Thus, as undergraduate engineering students, any project must incorporate this Canon. Another aspect that was considered when making recommendations for the Foisie Innovation Studio was that the campus will still be in operation while the renovation is taking place. This means that delivery and placement of materials must account for the flow of students through the “wind tunnel” to and from the quadrangle and ensure that students remain safe and relatively unaffected by the construction of the facility. The solutions the project team recommended accounted for this continued operation of the school.

To supplement the above stated ASCE Canon, *ASCE 7* and the *International Building Code* were complied with to ensure the structural integrity of the roof of Alumni

Gym. These documents defined the appropriate load combinations and minimum design loads to analyze and deem the structure safe for the public.

Professional Licensure

The field of engineering is considered a “profession” rather than an “occupation.” To have professional licensure indicates that you have the theoretical and technical capabilities to carry out reliable engineering work; but, an arguably more important skill set possessed by professionals is the ability to make ethical decisions to protect the public’s well-being. As a licensee, there are three major obligations: society, employer/clients, and other licensees. All three of these obligations are intertwined, and all decisions made by the professional engineer, to some extent, affect these groups.

Specifically, as a civil engineer, some of the responsibilities are to ensure that buildings and bridges are structurally sound, and roadways are designed to safely accommodate the flow of traffic, to give a couple of examples. It is essential that licensees perform and approve work within their areas of competence and that their decisions are based off sound engineering judgment. Often, due to varying license requirements by state, there will be instances where an engineer will be asked to seal a drawing outside of his/her area of expertise because he/she is the only person licensed to approve drawings in that particular state. This creates a difficult situation because the engineer will be held accountable for any incidents that happen as a result of the approved drawings.

Another important aspect of being a licensed engineer is to uphold the integrity and reputation of the engineering profession. Any decision made that creates unwanted or harmful outcomes reflects poorly on the engineer, other engineers in the profession, and undermines the public trust in the integrity and capability of professional engineers.

There is a reason why engineers are hired as consultants is because their opinions, experience, and judgment are trusted. Maintaining the positive reputation of engineers is essential to the profession.

The Commonwealth of Massachusetts bases its building code off of the 2009 version of the *International Building Code (IBC)* and provides additional amendments where they see fit. Based off of this code, a professional engineer will be required for this project. As stated in Section 107 of the *IBC*, the need for construction and design requirements to be approved by building officials and registered design professionals is highlighted. In the case of this project, a professional engineer will be required to review and stamp a structural analysis of the roof. The professional engineer would be required to approve the calculations and loading conditions used to evaluate the roof members and trusses. They would verify that the analysis has been done correctly and can assure the client that the roof will be able to withstand the anticipated loadings. Another area where this project may require a professional engineer is in the recommendations to further improve the building envelope performance. The opinion of a professional engineer carries much more weight than that of an unlicensed engineer, and the client would be more likely to trust the engineer's judgment and accept their recommendations.

Table of Contents

Abstract.....	i
Acknowledgements.....	ii
Authorship.....	iii
Capstone Design Statement.....	iv
Design Problem.....	iv
Scope of Work.....	v
Approach.....	vi
Realistic Constraints.....	viii
Economic.....	viii
Environmental/Sustainability.....	ix
Ethical.....	ix
Health & Safety.....	x
Professional Licensure.....	xii
Table of Figures.....	xvii
Table of Tables.....	xix
Chapter One: Introduction.....	1
Chapter Two: Background.....	4
2.1 Current Status of the Building.....	4
2.2 Energy Sustainability.....	9
2.3 Building Information Modeling (BIM).....	14
2.4 Thermal Calculations.....	18
2.4.1 Conduction.....	18
2.4.2 Infiltration.....	19
2.5 Thermal Imaging.....	21
2.6 Green Building Studio Validation.....	23
2.7 Storage Shed Test Runs.....	25
2.8 Structural Analysis.....	29
2.8.1 Building Codes and Design Aids.....	29
2.8.2 International Building Code.....	30
2.8.3 ASCE 7: Minimum Design Loads for Buildings and Other Structures.....	30
2.8.4 Load Combinations.....	35
2.8.5 Structural Roof System.....	37
Chapter Three: Existing Conditions (Phase One).....	40

3.1 Thermal Imaging.....	40
3.2 Creating the Model.....	42
3.3 Analyzing the Model.....	45
3.4 Conclusions.....	46
Chapter Four: Hand Calculation Validation.....	47
4.1 Energy Index Calculations.....	47
4.2 Methods for Hand Calculations.....	49
4.3 Conduction Calculation.....	50
4.4 Infiltration Calculation.....	51
Chapter Five: Planned Renovations (Phase Two).....	55
5.1 Creating the Model.....	55
5.2 Conclusion.....	59
Chapter Six: Potential Thermal Improvements (Phase Three).....	61
6.1 Triple Pane Windows.....	62
6.2 EIFS Finish.....	63
6.3 Increasing the Rigid Insulation.....	64
6.4 North Entrance Left as Existing Brick.....	65
Chapter Seven: Structural Analysis for Roof Mounted Solar Panels.....	67
7.1 Gathering Loads.....	68
7.2 Analyzing Existing Conditions.....	70
7.3 Analyzing the Addition of Solar Panels.....	71
7.4 Conclusion.....	77
Chapter Eight: Conclusions and Future Work.....	79
Works Cited.....	81
Appendix A: Project Proposal.....	85
Table of Contents.....	96
Appendix B: Personal Communication.....	128
Communication with the Architect.....	128
Communication with Professor Elovitz.....	130
Appendix C: <i>Green Building Studio</i> Calculation Information.....	133
Appendix D: Storage Test Runs.....	138
Appendix E: Phase One <i>Green Building Studio</i> Output.....	144
Appendix F: Calculated Life-cycle cost.....	149
Appendix G: <i>Green Building Studio</i> Error.....	150

Appendix H: Spreadsheet Calculations.....152
Appendix I: Truss Analysis of Existing Conditions155
Appendix J: Purlin Analysis of Existing Conditions156
Appendix K: Truss Analysis of Proposed Conditions.....157
Appendix L: Purlin Analysis of Proposed Conditions158
Appendix M: Solar Panel Array Analysis159
Appendix N: List of Electronic Files162

Table of Figures

Figure 1: Schematic for the proposed design of the new Showcase Atrium from the south entrance (Worcester Polytechnic Institute, 2013).	8
Figure 2: Suggested plan for Future West Promenade, connecting the parking garage and quadrangle with the fountain (located at orange star) and West Street (Worcester Polytechnic Institute, 2013).	9
Figure 3: Example LEED Certification criteria list. (Lott, 2011).	11
Figure 4: Material Usage (Smith & Tardif, 2012).	14
Figure 5: Thermal Image of a Typical Home (Thermography Proves Energy Efficiency of Post Frame Buildings, 2013).	23
Figure 6: Storage Room Partition Layout.	28
Figure 7: Basic Wind Speed (Taken from Figure 6-1C of ASCE-7).	33
Figure 8: East-West Section Cut (Original Blueprint).	38
Figure 9: Interior View of Roof Showing Completed Construction.	39
Figure 10: Exterior Wall 10'x 10' view.	41
Figure 11: Exterior Windows.	41
Figure 12: Interior Window.	42
Figure 13: Exterior Rendering.	44
Figure 14: Full Exterior.	44
Figure 15: Phase One Green Building Studio Energy Use Intensity.	47
Figure 16: Table displaying average fuel consumption in BTUs based on square footage of buildings (U.S. Department of Energy, 2006).	48
Figure 17: Interior and exterior thermal images of existing Alumni Gym.	54
Figure 18: South Entry Rendering level three.	57
Figure 19: North Entry Rendering.	57
Figure 20: Maker Space Rendering.	58
Figure 21: Alumni Gym Truss.	67
Figure 22: Wind direction definitions.	69
Figure 23: Location of maximum stresses.	71
Figure 24: Typical Connection Detail.	74
Figure 25: Roof Section with Solar Panel.	74
Figure 26: PV Array Support Spacing.	76
Figure 27: Proposed Solar Panel Arrangement.	77
Figure 28: Overview of Radiant Time Series Method.	135
Figure 29: Heat Capacity Equation.	136
Figure 30: Heat Conduction Equation.	136
Figure 31: <i>Green Building Studio</i> output for control run of the Storage Shed.	139
Figure 32: Test 7 design in the storage shed.	141
Figure 33: LCC Equation Breakdown	149
Figure 34: LCC Calculated Numbers.	
Figure 35: Error message encountered when trying to run the Green Building Studio that caused the simulation to fail.	150
Figure 36: Solution to error message provided by Autodesk.	151
Figure 37: Graph of hand calculated heat loss for existing and proposed building.	154

Figure 38: Graph generated by Green Building Studio for total heat loss of existing building.....154

Table of Tables

Table 1: Occupancy Categories (Taken from Table 1-1 of *ASCE 7-05*)..... 32

Table 2: *ASCE 7-ASD* vs. *IBC-ASD*..... 35

Table 3: *ASCE 7 - LRFD* vs. *IBC - LRFD*..... 35

Table 4: Calculated life-cycle cost of existing building..... 46

Table 5: Summary of Related Energy Intensities..... 48

Table 6: Infiltration Calculations Summary Table 54

Table 7: Calculated Heat Loss through the Windows 63

Table 8: Calculated Heat Loss for EIFS Finish..... 64

Table 9: Calculated Heat Loss through the roof..... 65

Table 10: Calculated Heat Loss through the new glass entrance 66

Table 11: Wind Pressures..... 69

Chapter One: Introduction

In recent years, there has been a large societal growth in environmental consciousness. Words such as “green” and “sustainable” are constantly in the headlines and are major topics of discussion for politicians, product development, and construction. The social awareness of climate change has resulted in new research and developments that focus on overall sustainability of buildings and reducing the production of greenhouse gases. With residential and commercial buildings accounting for roughly 40% of total energy consumption in the United States (U.S. Department of Energy, 2014), the construction of “green” buildings is a major focus for trying to reduce the overall amount of energy used. New techniques and materials for the construction and performance of buildings are constantly being utilized in an attempt to reduce the overall impact that buildings have on the environment.

Of that 40% of energy consumed, 48% is attributed to the heating and cooling of the building during operation. Newly constructed buildings are designed with a large focus on reducing the cost of operation to try and save the client money and reducing the overall impact of the building on the environment. These environmental issues become even more of a problem when dealing with renovations of old buildings due to the less sustainable building material used at the time.

Building enclosures built around the turn of the 20th century were often constructed using only brick and mortar, lacking the interior insulation commonly used in modern day construction. At that time, society placed little focus on the environmental

impacts of buildings. These buildings were built to last, but are often very inefficient from an energy standpoint. This project focuses on these environmental challenges in renovations for Alumni Gym, built in 1915 in the center of Worcester Polytechnic Institute's (WPI) campus.

Alumni Gym has recently lost its original use as a gym and recreation center due to the completion of the new WPI Sports and Recreation Center in 2012. The building has sat dormant for two years now with access closed off to students and faculty. The historic building is now set to be renovated and repurposed as the Foisie Innovation Studio, housing multiple disciplines and work areas. With any renovation, there are several areas of importance that must be addressed. This includes a structural analysis to assure the building is safe and in compliance with current codes; the interior construction and updates of old mechanical, electrical, and plumbing systems as well as interior partitions, changing the layout of the building to fit the new use; and the energy and environmental performance of the newly renovated building. WPI prides itself in building "green" and sustainable buildings, as showcased through the LEED certification of the four most recently built buildings: Bartlett Center, Faraday Hall, the Sports and Recreation Center, and East Hall.

This project used Building Information Modeling (BIM), thermal imaging, and conduction and infiltration calculations to analyze the building's current thermal performance. Areas of significant thermal losses were identified, and a number of improvements were tested using conduction and infiltration calculations. When calculating all of the information, only the impact of the heating performance was used.

The cooling aspect of the building was not taken into consideration for this project. Installment of renewable energy solutions was also investigated to help reduce the overall impact of the new renovation. All possible solutions were analyzed for performance, constructability, and monetary costs to gain a better understanding of whether or not a proposed solution would be feasible.

The following chapters provide background information, results and conclusions based upon the calculations made throughout the project. Chapter Two discusses all of the necessary background information needed to understand the concepts discussed in the report. Chapter Three documents Phase One of the project and demonstrates how the first model was created. Chapter Four discusses the process used to complete the hand calculations and how *Green Building Studio* was validated. Chapter Five illustrates the steps to complete the Phase Two model and also compares the results from the conduction and infiltration calculations between Phase One and Phase Two. Chapter Six analyzes how recommendations, different from the proposed design, could potentially affect the energy efficiency of Alumni Gym and uses calculations as a comparison between different phases of the project. Chapter Seven gives a detailed description about the structural analysis portion of the project. Lastly, Chapter Eight summarizes the conclusions after completion of the project and provides insight into future work.

Chapter Two: Background

The latest building renovation on Worcester Polytechnic Institute's campus, Robert A. Foisie Innovation Studio at Alumni Gym, will present multiple challenges to the designers and construction managers due to the building's age. Alumni Gym has stood atop the WPI campus for a century. The new design and renovation will have to modernize the interior to meet the new functional requirements for this facility. Upgrading all structural, mechanical, electrical, and plumbing systems will ensure compliance with the *Massachusetts Building Code*. The challenge in this project is that much of the old building, including the main structural components and exterior envelope, will remain in place to retain the historic character of the building. This will make interior work more selective and difficult. It also reduces the number of possible solutions to improve the thermal efficiency of the building because the existing enclosure is to remain as is. Energy sustainability affects both the environment and the overall operating costs of the building, making it a big point of discussion in modern times.

2.1 Current Status of the Building

Due to the fact that Alumni Gym was constructed in 1915, its historical value must be considered in terms of maintenance as well as any remodeling or renovating. In order to preserve the historical significance of Alumni Gym, the renovation will have little impact on the exterior appearance. In conversation with parties involved with the proposed project, there will be limited re-pointing of the brick, and there will not be any major changes to the façade of the building that would greatly differ from its original appearance. This is for both historical preservation as well as code compliance. If the

contractor were to try and improve the masonry, they would have to bring the masonry up to the current code, which could cause added scope and increased costs if it is found to be non-compliant with the code. Leaving as much of the existing structure “as is” in order to avoid complying with current codes can result in significant cost savings.

Currently, the design process of the renovation is complete while the construction component is still on hold. The architect for the project, Goody Clancy & Associates of Boston, developed finalized construction documents and BIM models for the design of the project. The construction manager for the project has also been selected and will be Shawmut Design and Construction based out of Boston, MA. They are currently involved in preconstruction services for the project. Shawmut has a prestigious reputation in the New England area, with offices based in Boston, MA; Providence, RI; New Haven, CT; and West Springfield, MA. The Boston office will be specifically handling the Alumni Gym renovation, with experience in projects very similar to the renovation of Alumni Gym as well as projects on the WPI campus. One project in particular that Shawmut completed in 1997 was Harvard’s Barker Center for the Humanities (Ruder, 1997).

The Barker Center for the Humanities was a 16-month renovation project completed in the summer of 1997, combining three historic buildings on Harvard’s campus: the Harvard Union (circa 1901), Burr Hall (circa 1911), and the Warren House (circa early 19th century). The project totaled 80,000 square feet of interior renovation (Shawmut Design and Construction, 1997) and involved an extensive interior redesign by the architect, Goody Clancy & Associates of Boston. The design strived to reconfigure the buildings to allow maximum use by the new programs that would be housed within the

space while still retaining and reusing the original buildings' materials, details, and overall historic character. The exteriors of these buildings were repaired and restored, involving minimal new additions in an effort to preserve the historic envelopes of the buildings (Ruder, 1997).

With this previous experience, both Goody Clancy & Associates of Boston and Shawmut Design and Construction have finalized the design phase of the Foisie Innovation Studio renovation project. The design focuses on repurposing the old gym and athletic center into an innovation studio that aims to assist students as a collaborative workspace for projects as well as a showcase for WPI student and alumni projects, innovations, and achievements. It will be the first physical presence on the WPI campus for the project-based curriculum at the university, termed the "WPI Plan". The project, in similar fashion to the renovation of the Barker Center, will focus on conserving the historical character of Alumni Gym. Originally constructed in 1915, Alumni Gym has sat at the center of the WPI campus for over a century (The Daily Herd, 2014). The new Foisie Innovation Studio renovation will still use the original exterior and structural components of the building, relying on the original materials of concrete, brick, steel, and yellow pine. These components will be repaired and updated as necessary to assure the building is structurally safe and as energy efficient as possible.

The new 34,255 square foot floor plan will feature a main 1,400 square-foot entryway that will be used to showcase the innovations and achievements of current and past WPI students. A schematic design for this entryway is shown in Figure 1. The overall aim for the renovation is to fill the need on campus for innovation space, tech suites, and

areas for project collaboration (The Daily Herd, 2014). The specific layout includes a new robotics lab in the existing swimming pool area; an exploration and discovery center with advanced analytical equipment; two lecture halls specifically for first-year Great-Problem Seminars; tech suites with flexible configurations to meet students' needs; a showcase atrium with interactive displays; an open, interactive collaborative workshop for students on the top floor in the existing basketball court area; and the creation of a second main entrance on the north side of the building facing the Campus Center. There are also plans for more office spaces, conference rooms, tool cribs, project pods, workbenches, and state-of-the-art hardware and software (Worcester Polytechnic Institute, 2013). The university hopes to utilize this building as a physical showcase of the project-based curriculum as well as to encourage mixing between student disciplines and class years, housing both first-year students taking Great Problem Seminars along with upper class students working in the collaborative areas on higher level projects, including fourth-year Major Qualifying Projects (The Daily Herd, 2014).



Figure 1: Schematic for the proposed design of the new Showcase Atrium from the south entrance (Worcester Polytechnic Institute, 2013).

The last main part of the renovation will be the removal of the current Alumni-Harrington Connector. This addition connects the two buildings through a series of locker rooms and athletic rooms. Due to the new WPI Sports and Recreation Center, this connector has also lost much of its use on the campus. Removal of this addition will create a new pathway from the quadrangle to the future West Promenade. Featured in Figure 2, the new promenade is planned to run behind the north side of Alumni Gym and along the south side of the Campus Center. The Foisie Innovation Studio at Alumni Gym will serve as a centerpiece of this promenade with the new north entrance helping to create a strong presence of the promenade (Worcester Polytechnic Institute, 2013).

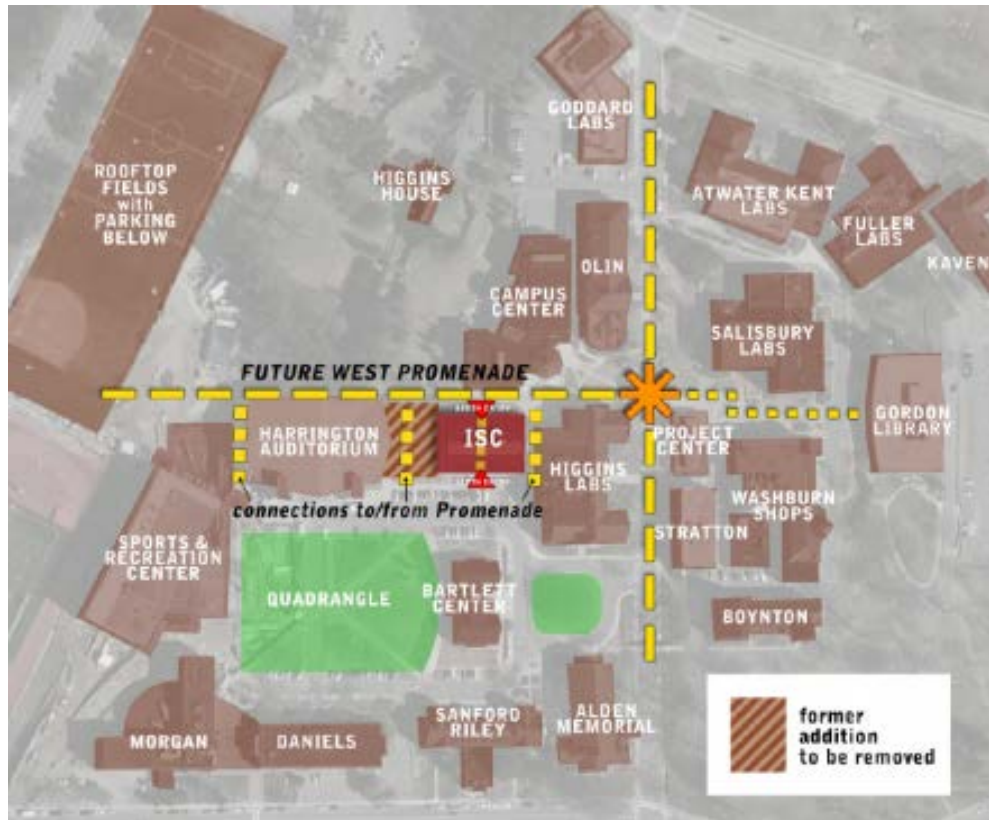

Figure 2: Suggested plan for Future West Promenade, connecting the parking garage and quadrangle with the fountain (located at orange star) and West Street (Worcester Polytechnic Institute, 2013).

2.2 Energy Sustainability

Historic landmarks and buildings constructed over 100 years ago have withstood the test of time. Most of these were built using thick masonry walls. While masonry is not the most thermally efficient building material, they help manage temperature control as the thickness keeps the heat in during the winter and the cold in during the summer. Also, the windows allow buildings to take advantage of the natural sunlight. However, most of these buildings need renovating because they are no longer used for their original purpose and the working parts of the building are outdated. More energy efficient technology is available to update these buildings to the 21st century.

Since the turn of the century, the need to construct buildings in a more energy efficient and environmentally sustainable way has increased significantly. Over-consumption of natural resources is a serious problem that cannot be ignored. Structures built in the early 1900s that still stand today are usually not demolished because it would cost less, use fewer resources and conserve more energy to renovate than demolish (Hensley, 2011). It can take nearly 80 years to break even with the environmental impact of demolishing an old building and erecting a new one (LEED, 2014). However, there are alternative solutions to help reduce their environmental footprint. Some of these alternatives include: mounting solar panels on roofs, installing low water consumption toilets and faucets, improving exterior insulation, upgrading existing windows and window locations, and setting up a recycling system. These aspects can help an old building achieve Leadership in Energy and Environmental Design (LEED) certification, which is the standard for more energy and environmentally efficient structures.

The LEED standard is aimed at reducing energy costs and pollution, as well as conserving resources such as energy, water, and recyclables. LEED certification gives recognition to buildings that strive towards environmental sustainability. These certified buildings serve as icons in a community, helping to elevate the community's standard for energy efficiency. In order for a building to receive LEED certification it has to receive a specific number of points. These points are awarded based on criteria that LEED has established. LEED focuses on sustainable sites, water efficiency, energy and atmosphere, materials and resources and indoor environmental quality when giving points towards certification. Figure 3 outlines the criteria for receiving these points.

LEED 2009 for New Construction and Major Renovations				Project Name
Project Checklist				Date
<input type="checkbox"/> Sustainable Sites		Possible Points: 26		
<input checked="" type="checkbox"/>	Prereq 1	Construction Activity Pollution Prevention		
<input checked="" type="checkbox"/>	Credit 1	Site Selection	1	
<input checked="" type="checkbox"/>	Credit 2	Development Density and Community Connectivity	5	
<input checked="" type="checkbox"/>	Credit 3	Brownfield Redevelopment	1	
<input checked="" type="checkbox"/>	Credit 4.1	Alternative Transportation—Public Transportation Access	6	
<input checked="" type="checkbox"/>	Credit 4.2	Alternative Transportation—Bicycle Storage and Changing Rooms	1	
<input checked="" type="checkbox"/>	Credit 4.3	Alternative Transportation—Low-Emitting and Fuel-Efficient Vehicles	3	
<input checked="" type="checkbox"/>	Credit 4.4	Alternative Transportation—Parking Capacity	2	
<input checked="" type="checkbox"/>	Credit 5.1	Site Development—Protect or Restore Habitat	1	
<input checked="" type="checkbox"/>	Credit 5.2	Site Development—Maximize Open Space	1	
<input checked="" type="checkbox"/>	Credit 6.1	Stormwater Design—Quantity Control	1	
<input checked="" type="checkbox"/>	Credit 6.2	Stormwater Design—Quality Control	1	
<input checked="" type="checkbox"/>	Credit 7.1	Heat Island Effect—Non-roof	1	
<input checked="" type="checkbox"/>	Credit 7.2	Heat Island Effect—Roof	1	
<input checked="" type="checkbox"/>	Credit 8	Light Pollution Reduction	1	
<input type="checkbox"/> Water Efficiency		Possible Points: 10		
<input checked="" type="checkbox"/>	Prereq 1	Water Use Reduction—20% Reduction		
<input checked="" type="checkbox"/>	Credit 1	Water Efficient Landscaping	2 to 4	
<input checked="" type="checkbox"/>	Credit 2	Innovative Wastewater Technologies	2	
<input checked="" type="checkbox"/>	Credit 3	Water Use Reduction	2 to 4	
<input type="checkbox"/> Energy and Atmosphere		Possible Points: 35		
<input checked="" type="checkbox"/>	Prereq 1	Fundamental Commissioning of Building Energy Systems		
<input checked="" type="checkbox"/>	Prereq 2	Minimum Energy Performance		
<input checked="" type="checkbox"/>	Prereq 3	Fundamental Refrigerant Management		
<input checked="" type="checkbox"/>	Credit 1	Optimize Energy Performance	1 to 19	
<input checked="" type="checkbox"/>	Credit 2	On-Site Renewable Energy	1 to 7	
<input checked="" type="checkbox"/>	Credit 3	Enhanced Commissioning	2	
<input checked="" type="checkbox"/>	Credit 4	Enhanced Refrigerant Management	2	
<input checked="" type="checkbox"/>	Credit 5	Measurement and Verification	3	
<input checked="" type="checkbox"/>	Credit 6	Green Power	2	
<input type="checkbox"/> Materials and Resources		Possible Points: 14		
<input checked="" type="checkbox"/>	Prereq 1	Storage and Collection of Recyclables		
<input checked="" type="checkbox"/>	Credit 1.1	Building Reuse—Maintain Existing Walls, Floors, and Roof	1 to 3	
<input checked="" type="checkbox"/>	Credit 1.2	Building Reuse—Maintain 50% of Interior Non-Structural Elements	1	
<input checked="" type="checkbox"/>	Credit 2	Construction Waste Management	1 to 2	
<input checked="" type="checkbox"/>	Credit 3	Materials Reuse	1 to 2	
<input type="checkbox"/> Materials and Resources, Continued				
<input checked="" type="checkbox"/>	Credit 4	Recycled Content	1 to 2	
<input checked="" type="checkbox"/>	Credit 5	Regional Materials	1 to 2	
<input checked="" type="checkbox"/>	Credit 6	Rapidly Renewable Materials	1	
<input checked="" type="checkbox"/>	Credit 7	Certified Wood	1	
<input type="checkbox"/> Indoor Environmental Quality		Possible Points: 15		
<input checked="" type="checkbox"/>	Prereq 1	Minimum Indoor Air Quality Performance		
<input checked="" type="checkbox"/>	Prereq 2	Environmental Tobacco Smoke (ETS) Control		
<input checked="" type="checkbox"/>	Credit 1	Outdoor Air Delivery Monitoring	1	
<input checked="" type="checkbox"/>	Credit 2	Increased Ventilation	1	
<input checked="" type="checkbox"/>	Credit 3.1	Construction IAQ Management Plan—During Construction	1	
<input checked="" type="checkbox"/>	Credit 3.2	Construction IAQ Management Plan—Before Occupancy	1	
<input checked="" type="checkbox"/>	Credit 4.1	Low-Emitting Materials—Adhesives and Sealants	1	
<input checked="" type="checkbox"/>	Credit 4.2	Low-Emitting Materials—Paints and Coatings	1	
<input checked="" type="checkbox"/>	Credit 4.3	Low-Emitting Materials—Flooring Systems	1	
<input checked="" type="checkbox"/>	Credit 4.4	Low-Emitting Materials—Composite Wood and Agrifiber Products	1	
<input checked="" type="checkbox"/>	Credit 5	Indoor Chemical and Pollutant Source Control	1	
<input checked="" type="checkbox"/>	Credit 6.1	Controllability of Systems—Lighting	1	
<input checked="" type="checkbox"/>	Credit 6.2	Controllability of Systems—Thermal Comfort	1	
<input checked="" type="checkbox"/>	Credit 7.1	Thermal Comfort—Design	1	
<input checked="" type="checkbox"/>	Credit 7.2	Thermal Comfort—Verification	1	
<input checked="" type="checkbox"/>	Credit 8.1	Daylight and Views—Daylight	1	
<input checked="" type="checkbox"/>	Credit 8.2	Daylight and Views—Views	1	
<input type="checkbox"/> Innovation and Design Process		Possible Points: 6		
<input checked="" type="checkbox"/>	Credit 1.1	Innovation in Design: Specific Title	1	
<input checked="" type="checkbox"/>	Credit 1.2	Innovation in Design: Specific Title	1	
<input checked="" type="checkbox"/>	Credit 1.3	Innovation in Design: Specific Title	1	
<input checked="" type="checkbox"/>	Credit 1.4	Innovation in Design: Specific Title	1	
<input checked="" type="checkbox"/>	Credit 1.5	Innovation in Design: Specific Title	1	
<input checked="" type="checkbox"/>	Credit 2	LEED Accredited Professional	1	
<input type="checkbox"/> Regional Priority Credits		Possible Points: 4		
<input checked="" type="checkbox"/>	Credit 1.1	Regional Priority: Specific Credit	1	
<input checked="" type="checkbox"/>	Credit 1.2	Regional Priority: Specific Credit	1	
<input checked="" type="checkbox"/>	Credit 1.3	Regional Priority: Specific Credit	1	
<input checked="" type="checkbox"/>	Credit 1.4	Regional Priority: Specific Credit	1	
<input type="checkbox"/> Total		Possible Points: 110		

Figure 3: Example LEED Certification criteria list. (Lott, 2011)

There are a total of 110 possible points that a building can earn towards becoming LEED certified, and four different levels of LEED certification that can be achieved. They are: Certification (40-49 points), Silver (50-59 points), Gold (60-79 points), or Platinum (80-110 points) (LEED for Schools, 2013).

In striving for more environmentally sustainable buildings, many modern building designs aim for their structure to operate at zero-net energy. This means that the building incorporates renewable energy and sustainable practices that nullify any energy it

consumes. One main way for a building to produce its own renewable energy is through the use of solar panels.

Solar Panels utilize photovoltaic cells to convert light energy into a usable source of electricity. By mounting these devices on roof tops, the amount of fossil fuels a building uses may be significantly reduced if a building is dependent upon electricity for heating, cooling and other utilities. Solar panels offer a return on investment between 6-15 years depending on the type of panel, the wattage output, how many panels are installed, and how much sunlight the panels receive daily (Gevorkian, 2012). However, often times these panels are very large and provide added dead, wind, snow, and seismic loads that an existing roof structure may not be able to sustain safely. These added loads, which are produced by the panels, could be dangerous for occupants of the building. Engineers must complete a structural analysis for roofs before the solar panels can be mounted. Once an engineer determines the roof can support the additional weight, the panels can be installed. Solar panels are one way a structure can work towards LEED certification.

Another aspect a building can incorporate when trying to achieve energy and environmental sustainability is the use of thermal insulation. As previously mentioned, most old buildings use thick walls as their main source of insulation. While these are effective, there are better solutions that have evolved over time. However, these brick structures can be extremely difficult to insulate on the interior due to the fact that the bricks get cold in the winter and placing insulation over these bricks will not allow the moisture from the warm inside air to escape and therefore the bricks rot. Another option can be to provide a vapor barrier behind the insulation to limit the penetration of

moisture. However, as discussed with Stephen Feige, an architect from Goody Clancy & Associates of Boston of Boston involved with the Alumni Gym renovation, this will only add to the freeze thaw within the bricks, causing further damage. His detailed response can be found in Appendix B.

Another option for insulating these old brick buildings is to insulate from the exterior using a layer of rigid foam cover with synthetic stucco. Also, insulating the windows of these old buildings will help achieve a more energy efficient building.

When windows are not insulated properly, they allow air to pass through rather easily. This is troublesome when trying to heat or cool the facility, increasing the amount of fuel or electricity consumed. Also, poorly insulated windows will allow condensation build up because, similar to the walls of a brick building, the moist indoor air comes in contact with the cold window, thus leaving water residue on the trim. To test how well a window's insulation performs, a person would need to check the U- or R-value. The R-value is a measure of a material's thermal resistance for conduction. The U-value is defined as the overall heat transfer coefficient for a material. These two values are inverses of each other (Bergman, Dewitt, Incropera, & Lavine, 2011). There are minimum U- and R-Values within the *Massachusetts Building Code* that new construction must follow. However, as discussed with Stephen Feige, since the Alumni Gym project is a renovation of a historic building, these requirements do not apply. As long as the existing envelope is not altered and the overall energy use of the building is not increased, then the minimum values do not need to be met. The full conversation can be found in Appendix B.

2.3 Building Information Modeling (BIM)

As touched upon earlier, one of the biggest challenges that the construction industry faces is maximizing the efficiency of operations and limiting the amount of resources required to complete a project. In a study conducted by the Construction Industry Institute, it was estimated that in 2004, 57% of total construction material spending was waste, which is the equivalent of over \$600 billion (Smith & Tardif, 2012). Figure 4, below, puts the amount of construction materials in perspective by comparing the usage of materials/products from several different industries (Smith & Tardif, 2012).

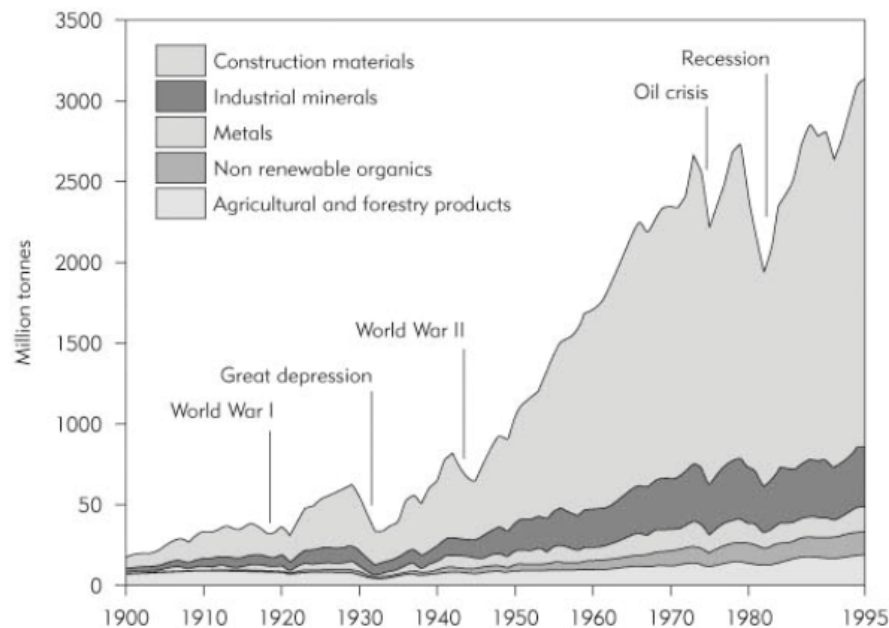

Figure 4: Material Usage (Smith & Tardif, 2012)

This figure suggests that the amount of materials being consumed for construction is increasing at a much faster rate in comparison to other industries. This is one reason why the construction industry has seen a large push towards sustainable design and construction. One of the ways that the construction industry has begun to mitigate the

waste of materials is through the implementation of Building Information Modeling (BIM) (Smith & Tardif, 2012).

Building Information Modeling is much more than creating three-dimensional visually appealing designs for clients and owners. It creates a line of communication between all parties involved on the project. BIM allows multidisciplinary information to be superimposed into one model, allowing parties to be more involved and in tune. Some of the tasks that BIM can provide are quantity takeoffs, energy analyses, schedules, clash detections, and material lists (Epstein, 2012). These tasks can be performed quickly and with greater accuracy, saving time and money. Although BIM software licensing fees can give the initial impression that it may not be economically feasible to utilize these technologies, studies have shown that increasing the upfront costs (roughly 2% for sustainable design) results, on average, in 20% savings of the total construction costs over the project's life cycle (Kats et al, 2003).

Today, there are many companies that do use BIM. However, these companies often rely on BIM to only get them through the design and construction of the project. BIM, however, also has potential to be used after the completion of construction through facilities management. When the BIM model is used to its full potential, facility managers have the ability to look at the model and quickly find information versus looking through numerous drawings. BIM can also help with energy analysis, helping to reduce the environmental footprint of construction and operation of the building. BIM allows designers to create an accurate model presentation that reflects the proposed properties of a building, including thermal properties. Energy analysis software uses the thermal

properties and conducts simulations that calculate the estimated energy efficiency of the building. An example of this potential cost savings occurred with the University of South Carolina's use of BIM technology. Their use of BIM in designing new buildings on campus is expected to save them approximately \$900,000 over the next ten years at current energy costs (Gleeson, 2008). Their use of sustainable design and BIM technology helped optimize their buildings for energy efficiency. Modifying the coordinates of the building to conduct daylight analyses, looking at site logistics, and creating energy models to see live and projected energy consumption are just a few of the ways that BIM was used to give the University of South Carolina such significant savings (Gleeson, 2008). This is where the team sees the project having the greatest potential.

Since Alumni Gym is an existing structure that was built over 100 years ago, there was little technology available compared to modern day. Designers had to rely on two-dimensional blueprints to visualize and analyze the building before it was constructed. Currently, there are BIM models that have been created to show both the existing structure and the proposed geometric changes for the soon to be Foisie Innovation Studio. Utilizing these models, an energy analysis of the building can be conducted. The thermal performance of the building can be observed and translated into energy costs.

In a survey conducted by Azhar and Brown (2009), out of 91 design and construction firms, the most popular and powerful sustainability software programs are *Autodesk Green Building Studio*, *Autodesk Ecotect*, and *Integrated Environmental Solutions' Virtual Environment*. Some of the key features that these programs provide are (Autodesk, 2010):

- **Thermal analysis:** Calculate the cooling and heating loads for models and observe the effects of equipment, occupancy, infiltration, and internal gains.
- **Energy Star & LEED Points:** Based on the performance and material usage Energy Star and LEED certification points are given.
- **Real time energy usage and costs:** Current energy costs can be input to provide an accurate estimate of yearly, monthly, daily, and hourly energy costs. The software uses a global weather database to simulate the conditions the building may face.
- **Photovoltaic collection:** Panel type, assumed installation costs, and electric utility costs are input to generate a payback period based on the photovoltaic potential of the building.
- **Daylight factors:** Calculate daylight factors and illuminance levels at any point in the model. Observe the sun's path and position relative to the model at any date, time, and location.

Another option for energy analysis, that has recently become available, is the use of *Autodesk Revit*. The latest versions of *Autodesk Revit* include energy analysis capabilities for both conceptual and detailed building design. In fact, *Revit* has absorbed the majority of the features that *Ecotect* can provide, using *Green Building Studio's* cloud-based services. By setting some initial parameters such as location, building use, and thermal properties for materials, a report is generated giving yearly energy costs and potential areas for savings.

With these BIM programs, it is simple and efficient to test a variety of sustainable solutions and investigate the effects on cost and energy use. For more detailed information on the equations that *Green Building Studio* uses to calculate these costs, please see Appendix C. From an economic standpoint, for this project, *Autodesk Revit's* free student license with full analysis capabilities and subscription to *Green Building*

Studio would be more resource friendly than purchasing a student license of *Integrated Environmental Solutions' Virtual Environment* for \$80 per license.

2.4 Thermal Calculations

In order to determine the building's thermal efficiency, a full thermal analysis must be conducted. A thermally efficient building would perform well in preventing heat flow through its exterior. Conducting a thermal analysis helps identify the main areas of heat loss and thermal gain in the building. A high performance would mean that the building is effective at keeping heat inside while there are lower temperatures outside, or vice versa. The two main methods of thermal analysis for this project are conduction and infiltration.

2.4.1 Conduction

Conduction is the process of heat transfer through a surface. In regard to this project, it is specifically the heat transfer through the windows, doors, exterior brick, and roof. In order to evaluate the conduction and thermal efficiency, the process of heat transfer through a surface must be researched and understood by the project team. The main factor that affects the conduction through a surface is the heat transfer coefficient, represented by the letter U. It varies among building materials, such as brick, insulation, window, etc., and the thickness of said material. Although the same equation is used for all materials, the heat transfer coefficient changes (Bergman, Dewitt, Incropera, & Lavine, 2011). The main equation for conductive heat transfer through a surface is:

$$q = U * A * (T_i - T_o) \quad (1)$$

Where:

q = heat flow through conduction (BTU)

U = heat transfer coefficient (based on material)

A = cross sectional area of the wall (ft²)

T_i = temperature inside the building (°F)

T_o = temperature outside the building (°F)

However, to account for the changing temperature throughout the month, heating degree days were used. Heating degree days, as defined and provided by the National Oceanic and Atmospheric Administration (NOAA), involve finding “the day’s average temperature by adding the day’s high and low temperatures and dividing by two. If the number is above 65, there are no heating degree days that day. If the number is less than 65, subtract it from 65 to find the number of heating degree days” (National Oceanic and Atmospheric Administration). This data is readily available online at NOAA’s website for cities throughout the USA. Heating degree days account for the constantly changing temperature through the year. Therefore, the equation became:

$$q = U * A * HDD \quad (2)$$

2.4.2 Infiltration

As well as the conductive heat transfer in the building, the infiltration of the building must be considered when conducting a thermal analysis. The infiltration is the air leakage in the building, or heat loss through the opening of windows, doors, or cracks in walls/windows in the building. Infiltration is specifically any air that enters the building, whether warm or cool air, which replaces the air already in the building. Some buildings may be described as airtight, which specifically means that the infiltration in the building

is relatively low. The infiltration rate is added to the conduction values as internal heat loss for the building.

There have been various studies on infiltration rates for residential and commercial buildings. Almost all experiments include “blower door” tests, which involves blowing air out of a building, thus lowering the internal pressure of the building. After, analysts can detect air leaks in the building because of the pressure difference of the outside air to inside air. However, blower door tests are typically conducted in residential settings. A blower door test was out of the scope of this project, so the infiltration rate had to be estimated through other means – specifically hand calculations and thermal imaging (Southface Energy Institute, 2011).

In real terms, infiltration is “the volumetric flow rate of outside air into a building, typically in cubic feet per minute (CFM)...” (U.S. Department of Energy, 2011). The main unit of measurement for infiltration is called air changes per hour (ACH), which is a measure of the volume of air being replaced in the building per hour. The ACH rate is estimated in many instances, based on actual pressure differential between the outside/inside air and an ideal pressure differential. However, there have been studies conducted in different occupancies to determine an ideal ACH benchmark value, typically taken at a 50 Pa pressure differential (U.S. Department of Energy, 2011).

Alumni Gym had many different uses when it was still open to students, coaches, and other campus personnel. A few occupancies considered for this project were public offices, private offices, and commercial occupancies. Public offices had an ACH value of 3; private offices had an ACH value of 4; and commercial occupancies have a typical ACH

value of 4.9 – 7.5. These values are largely dependent on the design of the exterior (number of doors and windows) as well as the amount of traffic in and out of the building that is experienced (Fennell & Haehnel, 2005) and (Bowman, n.d.). Without computer software to calculate the infiltration rate, these ACH values must be included in hand calculations to find the total infiltration rate of the building. Derived from the units and our estimation of the ACH values, the equation for the infiltration rate is shown below. A more detailed determination of the ACH values and the calculation will be included in the methodology.

$$I = V * ACH * c_p * \rho * HDD \quad (3)$$

Where:

I = infiltration rate (BTU/h)

V = volume of the building (ft³)

ACH = air changes per hour (1/h)

c_p = specific heat capacity of air (BTU/lb°F)

ρ = density of air (lb/ft³)

HDD = heating degree day for the desired month

2.5 Thermal Imaging

For the thermal analysis of Alumni Gym, thermal imaging will be used to determine areas of significant heat loss. However, thermal imaging has many applications other than detecting heat loss. Night vision goggles utilize thermal imaging features because the human body gives off heat that will contrast to any surroundings. Surveillance cameras with thermal capabilities are used by border patrol services, both land and sea, because they are able to spot targets up to a few miles away (FLIR, 2014). Firefighters can use thermal cameras during a fire because they will be able to find people through thick smoke, see holes in floors/walls due to burning, and even find where the

fire originated to suppress the high volume of heat being released (Firefighting Applications, 2014). Some other major applications of thermal imaging include search and rescue of missing persons, medicinal diagnostics, and energy audits in buildings, similar to the research that was conducted.

Thermal imaging allows for collecting information on a building's thermal efficiency over a large-scale area. Taking pictures of larger areas allows for insight into areas of thermal weakness in the building envelope where air leakages and abnormal heat transfer are occurring. Thermal cameras use gray-scale colors to allow for a qualitative measure of intensity of heat transfer through a surface. Dark or "cool" colors, such as black, blue, or purple, show that there is virtually no heat transfer through the surface. A structural member such as a beam, girder, or column, is one example where thermal images would display these darker colors. On the contrary, "hotter" colors such as yellow, orange, and red, indicate that there is significant heat transfer through the surface. Thermal images would most likely show these colors near windows or doors.

Shown below in Figure 5 is a thermal image of a typical home. The structural columns on the front porch show deep colors, which imply that there is little to no heat transfer through this section of the house. However, near the windows and front door, there are bright orange-red colors, which indicate high heat transfer through the surfaces. These are the surfaces in a building that display the highest heat transfer because there is not as much insulation at these areas.



Figure 5: Thermal Image of a Typical Home (Thermography Proves Energy Efficiency of Post Frame Buildings, 2013)

Two different camera types, the FLIR i7 and the FLIR E40 model will be utilized to capture the thermal images. These images are taken in JPEG format so they are simple to work with when analyzing pictures for heat patterns. The i7 device shows temperature data on screen and is displayed in the picture as well. It works in temperatures ranging from -20°C to 250°C to a deviation of $\pm 2^{\circ}\text{C}$. The FLIR i7 can be operated using three different color palettes, allowing for very accurate readings for easy comparison (FLIR i3/i5/i7, 2014). The FLIR E40 is slightly more advanced than the i7. It works in ranges from -20°C to 650°C and can zoom to 2x normal distance for accurate readings of small areas. Temperature ranges can be set automatically, ranging from the highest and lowest temperatures shown on the screen, more manually to a specific temperature range. The thermal image is shown side-by-side with an actual picture so it is easier to understand what exactly the image is showing. It has ten different color palettes to choose from, which is many more than the i7 (New FLIR E-Series and E-Series bx, 2014).

2.6 Green Building Studio Validation

Prior to using and trusting a computer software program as complex as the *Green Building Studio* program, both the software and the individual test runs must be validated

to assure they are accurate. Validating the entire program through use of hand calculations would be challenging, requiring multiple extensive calculations to determine the total heat loss. Thus, prior to attempting any hand calculations, previous validations of the program as a whole were investigated and studied. *Green Building Studio* uses the DOE-2.2 simulation engine, as explained in Appendix C. *Green Building Studio* performs its own validation testing, comparing its results for each new version against the ASHRAE Standard 140, a standard method for testing the validity of building energy analysis computer programs. By meeting this standard, *Green Building Studio* was certified by the U.S. Department of Energy in 2008 as a qualified computer software program when calculating federal tax incentive requirements. Furthermore, the DOE-2.2 simulation engine has been validated through tests done by the Lawrence Berkeley National Laboratory and the Los Alamos National Laboratory (Autodesk, 2014). There have been multiple reports published validating *Green Building Studio*, including one by the University of Florida (Olbina & Reeves, 2012) and the Lawrence Berkeley National Laboratory (Hong, Wang, Yan, & Zhu, 2012).

The ASHRAE Standard 140 is a standard method of testing for the evaluation of building energy analysis computer programs. There are six major possible methods for validating whole building energy simulations (Judkoff & Neymark, 2006):

- a) Comparative tests – building envelope
- b) Comparative tests – mechanical equipment and on-site energy generation equipment
- c) Analytical verification – building envelope
- d) Analytical verification – mechanical equipment and on-site energy generation equipment

- e) Empirical validation – building envelope
- f) Empirical validation – mechanical equipment and on-site energy generation equipment.

ASHRAE Standard 140 focuses on bullet a) and d). The latest version of the ASHRAE Standard 140, developed in 2011, uses the IEA BESTEST methodology for performing validations of whole building simulations (Sefaira Fulcrum, 2014). The IEA BESTEST is a series of tests that were reported to be used as standard case tests to which energy simulations could be compared (U.S. Department of Energy, 2011). The goal of these validations is to assure that no errors have occurred in the program that can lead to large skews in the data outputs. The US Department of Energy's National Renewable Energy Laboratory (NREL) developed its own overall methodology to assure the accuracy of these programs; the methodology of NREL has been adopted by these industry standards (Judkoff & Neymark, 2006). The purpose of these standards is to perform comparative tests of the software to a broad range of known test cases, parametric interactions, and output types (Autodesk, 2014).

2.7 Storage Shed Test Runs

Before beginning analysis on the existing Alumni Gym building, a model of an existing storage shed on the WPI campus was created. The shed is a single room with a garage door on one end, two person doors, and multiple windows. A site visit was performed, with exact measurements taken and the materials of the building noted. The window structures and pane thicknesses, the dimensions of every opening in the brick exterior, and the thickness of the brick envelope were all recorded. Locations and photos of the site around the building were also taken, noting the size and location of landscaping

and trees in the immediate area. All of this information was then used to create an accurate representation of the building and surrounding site in a *Revit* model.

The model was used to perform test runs with *Green Building Studio*, allowing a deeper understanding of the major factors that affect the Life-cycle cost assessment conducted by *Green Building Studio* on a small, simple building. Each simulation run was done with changing one element of the building, with the existing conditions serving as a control level. The effects of each individual change were measured based on their overall change to the environmental footprint of the building.

The factors that were investigated included:

1. Insulation in roof
2. Insulation in exterior walls
3. Layout of interior partitions
4. Thickness of interior partitions
5. Insulation in interior partitions
6. Orientation of building with true north
7. Type of heating system
8. Building Type
9. Curtain walls in place of exterior wall
10. Effect of sun path option
11. Effect of analytical space and surface resolution changes

These factors were investigated one by one, modifying the model each time based off the control conditions.

The baseline control run of the storage shed with correct existing conditions yielded a 30-year life-cycle energy cost of \$49,992, with the simulation using a 6.1% discount rate. The simulation assumed an electrical cost of \$0.14/kWh and a fuel cost of \$1.16/Therm for calculation of the energy cost. All prices and rates were held constant

for all simulations. The factor that yielded the largest change was the type of HVAC system assumed by the simulation. Within the energy analysis options, there is a drop down menu containing twelve standard heating systems that are commonly used in buildings. These HVAC systems use various sources of energy, are of various sizes, strengths, and capacities, and have different efficiencies, resulting in different lifecycle costs and performances. Based on this selection, the simulation is able to more accurately calculate the heating and cooling loads. The control simulation utilized a Central VAV, HW Heat, Chiller 5.96 System. Changing this system to a 12SEER/0.9 AFUE Split/Packaged 5-11 ton reduced the life-cycle cost from \$49,992 down to \$22,640, a reduction in cost of roughly 55%. It was not unexpected that the efficiency of the heating system resulted in such a large affect to the life-cycle energy costs since the heating and cooling of the building accounts for such a large amount of a building's energy costs. The simulation highlighted that in the large analysis of Alumni Gym, the HVAC system needed to be as accurate as possible.

The next major factor that affected the life-cycle cost of the storage shed was the amount of insulation on the exterior surfaces of the shed. For this simulation, the exterior partitions and roof assemblies had two inches of rigid insulation and a layer of ½" drywall added. The simulation took into account the increased thermal properties of the exterior surfaces of the building to calculate the life-cycle energy costs. The improved exterior surfaces resulted in a life-cycle energy cost reduction of over \$10,000. This was a reduction of 28%.

The next major factor that affected the life-cycle energy cost was the layout of the interior partitions. The layout of the interior affected the energy more so than the thickness and amount of insulation in the interior partitions. When the original, single room storage shed was split into three rooms, one partition running the length of the building and a second partition running perpendicular, as shown in Figure 6, the life-Cycle Energy cost increased to \$51,229, an increase of roughly 2.5%.

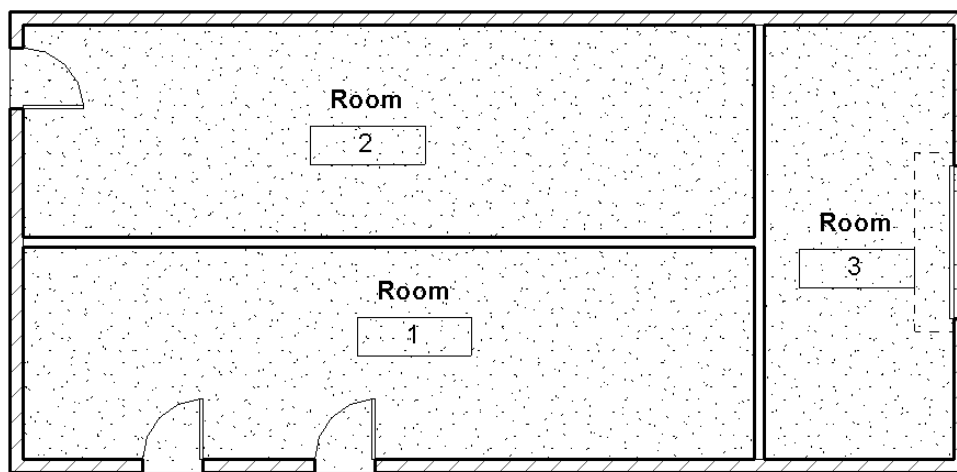

Figure 6: Storage Room Partition Layout

When the shed was divided into six rooms of equal size, the cost further increased to \$56,855, an increase from the control of 13.7%. Thick interior partitions and insulation in the six-room model had little effect on the simulation, only decreasing the costs by \$21 to \$56,834. When simulations occur on the large model, more focus will have to be given to the interior layout and less on the materials used for the interior partitions as the test runs provide evidence to the larger effect of the interior layout in the simulation.

The other factors tested with the storage shed model had negligible effects on the life cycle energy cost. For a full discussion of the storage shed test runs and the conclusions drawn, please refer to Appendix D.

2.8 Structural Analysis

When Alumni Gym was originally constructed in 1915, structural design practices were not as developed as they are today. Much of early design was based off experience, engineering judgment, and prescriptive building code requirements; whereas today the use of performance-based design calculations, finite element software programs, and more representative load cases are used in supplement to engineering judgment. With early design so heavily reliant on judgment and experience, often buildings were overdesigned. The “rule-of-thumb” approach is often very conservative in order to account for, in the case of structural engineering, various loading patterns and uncertainty with structural elements and materials.

2.8.1 Building Codes and Design Aids

Today the design and analysis of structures is heavily reliant on the use of codes, industry standards, and established practices for design and analysis. Building codes can vary from state-to-state, but the core of each state’s building codes is the *International Building Code (IBC)* and *ASCE 7 Minimum Design Loads for Buildings and Other Structures (ASCE 7)*. The variations in building codes are expressed in terms of amendments or supplemental criteria to the *IBC* and *ASCE 7* that must be followed. For example, Figure 6-1 and 7-1 in *ASCE 7* provide maps that document Basic Wind Speed and Ground Snow

Loads respectively. Each figure defines values for wind (mph) and snow (lb/ft²) that certain areas or regions can expect. The Commonwealth of Massachusetts provides an amendment to this figure by tabulating City/Town specific values for wind and snow. For buildings located in Worcester, MA, such as Alumni Gym, the ground snow load to consider, p_g , is 50 lb/ft² and the design wind speed to consider is 100 mph. The use of *IBC* and *ASCE 7* will now be explained further.

2.8.2 International Building Code

The Commonwealth of Massachusetts still abides by *IBC 2009* regulations. Although *IBC 2012* has since been released, the State has instead opted to make amendments to the 2009 edition rather than adopt the 2012 release altogether. One key aspect of the *IBC* is the inclusion of certain load combinations in regards to both LRFD and ASD. Similar to *ASCE 7*, *IBC 2009* provides 7 main load combinations for LRFD. These load combinations will be discussed further in section 2.8.4.

2.8.3 ASCE 7: Minimum Design Loads for Buildings and Other Structures

ASCE 7 Minimum Design Loads for Buildings and Other Structures provides the essential loading information that needs to be considered when designing a new structure or analyzing an existing one like Alumni Gym. The most recent edition of *ASCE 7* is *ASCE 7-10*, but it has not yet been adopted by the *Mass. Building Code*. The Commonwealth of Massachusetts abides by *IBC 2009*, which references *ASCE 7-05*, and bases its amendments off the 2009 version. For the purposes of this project, *ASCE 7-05* and *IBC 2009* will be the versions referenced.

Regardless of the version, *ASCE 7* begins with general information providing the reader with background on the terminology used in the standard as well as the general criteria that a structure must meet. One of the first items to determine before assigning loads to a structure is the occupancy category. These are broken down into four categories, ranging from non-essential facilities such as barns (Category I) to essential facilities such as hospitals (Category IV). These categories can also be associated with level of risk and the importance of the structure to maintain its integrity. For example, if an earthquake or hurricane occurred, it would be essential for hospitals to remain operable because they house many people and will be relied upon for emergency medical purposes. On the other end, if a barn were exposed to these conditions, it will not cause much residual damage, in terms of affecting the public, if the structure were to fail. In the case of Alumni Gym, it is considered a Category III facility because of its occupant capacity. This category will later be used to calculate the Wind, Snow, Earthquake, and Ice Loads. Table 1-1 in *ASCE 7* (Table 1 below) shows the criteria for each occupancy category.

Table 1: Occupancy Categories (Taken from Table 1-1 of ASCE 7-05)

TABLE 1-1 OCCUPANCY CATEGORY OF BUILDINGS AND OTHER STRUCTURES FOR FLOOD, WIND, SNOW, EARTHQUAKE, AND ICE LOADS

Nature of Occupancy	Occupancy Category
Buildings and other structures that represent a low hazard to human life in the event of failure, including, but not limited to: <ul style="list-style-type: none"> • Agricultural facilities • Certain temporary facilities • Minor storage facilities 	I
All buildings and other structures except those listed in Occupancy Categories I, III, and IV	II
Buildings and other structures that represent a substantial hazard to human life in the event of failure, including, but not limited to: <ul style="list-style-type: none"> • Buildings and other structures where more than 300 people congregate in one area • Buildings and other structures with daycare facilities with a capacity greater than 150 • Buildings and other structures with elementary school or secondary school facilities with a capacity greater than 250 • Buildings and other structures with a capacity greater than 500 for colleges or adult education facilities • Health care facilities with a capacity of 50 or more resident patients, but not having surgery or emergency treatment facilities • Jails and detention facilities Buildings and other structures, not included in Occupancy Category IV, with potential to cause a substantial economic impact and/or mass disruption of day-to-day civilian life in the event of failure, including, but not limited to: <ul style="list-style-type: none"> • Power generating stations^d • Water treatment facilities • Sewage treatment facilities • Telecommunication centers Buildings and other structures not included in Occupancy Category IV (including, but not limited to, facilities that manufacture, process, handle, store, use, or dispose of such substances as hazardous fuels, hazardous chemicals, hazardous waste, or explosives) containing sufficient quantities of toxic or explosive substances to be dangerous to the public if released. Buildings and other structures containing toxic or explosive substances shall be eligible for classification as Occupancy Category II structures if it can be demonstrated to the satisfaction of the authority having jurisdiction by a hazard assessment as described in Section 1.5.2 that a release of the toxic or explosive substances does not pose a threat to the public.	III
Buildings and other structures designated as essential facilities, including, but not limited to: <ul style="list-style-type: none"> • Hospitals and other health care facilities having surgery or emergency treatment facilities • Fire, rescue, ambulance, and police stations and emergency vehicle garages • Designated earthquake, hurricane, or other emergency shelters • Designated emergency preparedness, communication, and operation centers and other facilities required for emergency response • Power generating stations and other public utility facilities required in an emergency • Ancillary structures (including, but not limited to, communication towers, fuel storage tanks, cooling towers, electrical substation structures, fire water storage tanks or other structures housing or supporting water, or other fire-suppression material or equipment) required for operation of Occupancy Category IV structures during an emergency • Aviation control towers, air traffic control centers, and emergency aircraft hangars • Water storage facilities and pump structures required to maintain water pressure for fire suppression • Buildings and other structures having critical national defense functions Buildings and other structures (including, but not limited to, facilities that manufacture, process, handle, store, use, or dispose of such substances as hazardous fuels, hazardous chemicals, or hazardous waste) containing highly toxic substances where the quantity of the material exceeds a threshold quantity established by the authority having jurisdiction. Buildings and other structures containing highly toxic substances shall be eligible for classification as Occupancy Category II structures if it can be demonstrated to the satisfaction of the authority having jurisdiction by a hazard assessment as described in Section 1.5.2 that a release of the highly toxic substances does not pose a threat to the public. This reduced classification shall not be permitted if the buildings or other structures also function as essential facilities.	IV

^dCogeneration power plants that do not supply power on the national grid shall be designated Occupancy Category II.

To generate the values for the minimum loads to use to evaluate a structure, ASCE 7 provides multiple chapters on how to calculate atmospheric loadings such as wind, snow, seismic and ice. Each loading type is unique in the way that the loading is calculated. For example, wind loading has various factors to account for, such as exposure category, elevation, geographical location, and the building’s surroundings. Chapter 6 of ASCE 7 provides the steps to calculate these factors and translate them into a design pressure in pounds per square foot that acts on the surfaces of the exterior enclosure. Figure 6-1C in ASCE 7 (Figure 7 Below) provides an example of basic wind speeds for the Mid- and

Northern Atlantic Hurricane Coast Line. These values can be used barring the state in which the work is being completed does not have any provisions in their building code that states a specific value for basic wind speed.

This space has been intentionally left blank

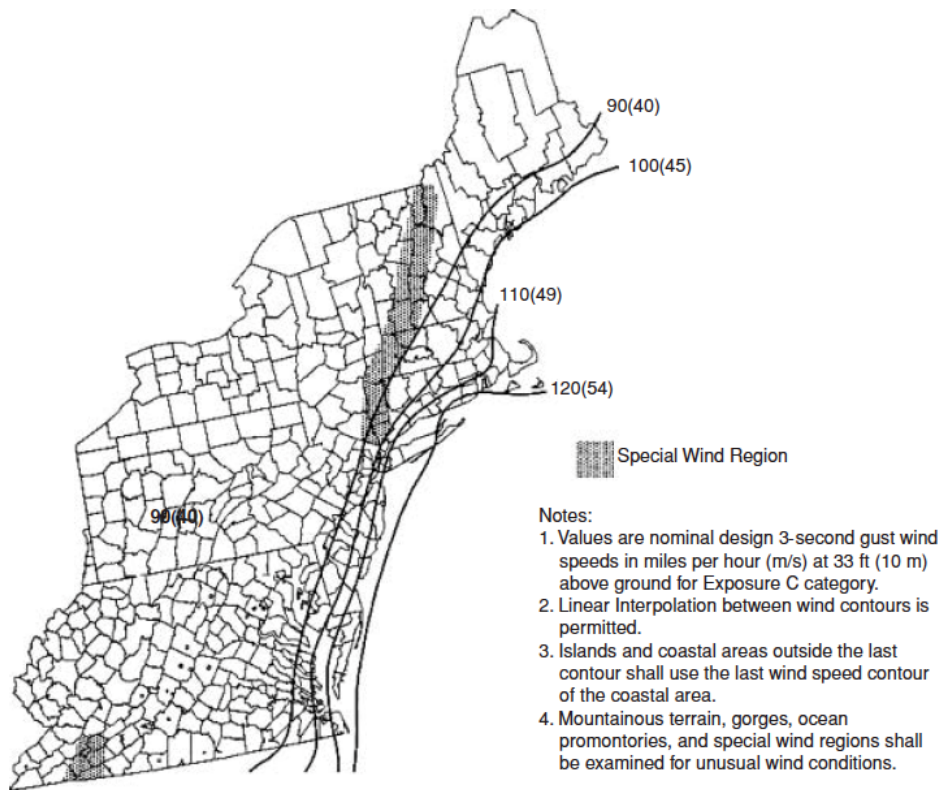

FIGURE 6-1C BASIC WIND SPEED—MID AND NORTHERN ATLANTIC HURRICANE COASTLINE

Figure 7: Basic Wind Speed (Taken from Figure 6-1C of ASCE-7)

The basic wind speed taken from Figure 6-1 of ASCE 7 or basic wind speed defined by the applicable jurisdiction, is then used to calculate the pressures (a function of velocity

squared) at a given height, h . The equation below (Equation 6-15 in *ASCE 7-05*) shows the varying coefficients that are used to adjust the wind pressures for topographical effects, directionality, and height.

$$q_z = 0.00256K_zK_{zt}K_dV^2I \quad (4)$$

Another significant lateral force that must be accounted for is seismic loading. In the event of an earthquake, a structure must be able to withstand the shearing force as a result of the ground surface accelerating. Fundamentally, the force is the product of the mass of the structure times the ground acceleration, but other factors for soil-structure interaction and structural ductility must be included. Similar to the wind maps in Chapter 6 of *ASCE 7*, maps to determine the spectral response acceleration are provided in Figures 22-1 to 22-14 in *ASCE 7-05*. These values are used to define site coefficients, which are then used to calculate the fundamental period, T_s , of the structure. Defining these variables allows the calculation for effective base shear of the structure. Once the base shear is determined, it can then be distributed along the height of the building. This is called the Equivalent Lateral Force Method, and is explained in Section 12.8 of *ASCE 7-05*. This method uses the weight of sections of a structure (i.e. stories) and the height at which they are located to assign a lateral force value at the specified elevation. As the building height increases, the greater the forces will be experienced at the top of the structure. This can result in significant lateral deflections, or side sway, that can cause structural failures and damage to non-structural elements. The lateral movements are affected by the rigidity of the structure and although these movements can be limited by building a

very rigid structure, it also needs to be ductile to withstand the significant loading that comes with a seismic event.

2.8.4 Load Combinations

Both *ASCE 7* and *IBC* provide information regarding load combinations for both Load Resistance Factor Design (LRFD) and Allowable Stress Design (ASD). These combinations are used to build load cases and ultimately determine the governing design loading. For the purposes of this project, LRFD will be the approach used based on previous experience. Below, in Table 2 and

Table 3, a comparison of the load combinations for both ASD and LRFD from *ASCE 7* and *IBC* is displayed.

Table 2: ASCE 7-ASD vs. IBC-ASD

ASCE 7- ASD	IBC- ASD
$D + F$	$D + F$
$D + H + F + L + T$	$D + H + F + L + T$
$D + H + F + (L_r \text{ or } S \text{ or } R)$	$D + H + F + (L_r \text{ or } S \text{ or } R)$
$D + H + F + 0.75(L + T) + 0.75(L_r \text{ or } S \text{ or } R)$	$D + H + F + 0.75(L + T) + 0.75(L_r \text{ or } S \text{ or } R)$
$D + H + F + (W \text{ or } 0.7E)$	$D + H + F + (W \text{ or } 0.7E)$
$D + H + F + 0.75(W \text{ or } 0.7E) + 0.75L + 0.75(L_r \text{ or } S \text{ or } R)$	$D + H + F + 0.75(W \text{ or } 0.7E) + 0.75L + 0.75(L_r \text{ or } S \text{ or } R)$
$0.6D + W + H$	$0.6D + W + H$
$0.6D + 0.7E + H$	$0.6D + 0.7E + H$

Table 3: ASCE 7 - LRFD vs. IBC - LRFD

ASCE 7 – LRFD	IBC - LRFD
$1.4(D+F)$	$1.4(D + F)$
$1.2D+1.6L+0.5(L_r \text{ or } S \text{ or } R)$	$1.2(D + F + T) + 1.6(L + H) + 0.5(L_r \text{ or } S \text{ or } R)$
$1.2D + 1.6(L_r \text{ or } S \text{ or } R) + (L \text{ or } 0.8W)$	$1.2D + 1.6(L_r \text{ or } S \text{ or } R) + (f_1L \text{ or } 0.8W)$
$1.2D + 1.6W + L + 0.5(L_r \text{ or } S \text{ or } R)$	$1.2D + 1.6W + f_1L + 0.5(L_r \text{ or } S \text{ or } R)$
$1.2D + 1.0E + L + 0.2S$	$1.2D + 1.0E + f_1L + f_2S$

$0.9D + 1.6W + 1.6H$	$0.9D + 1.6W + 1.6H$
$0.9D + 1.0E + 1.6H$	$0.9D + 1.0E + 1.6H$

Where:

D = Dead Load	L _r = Roof Live Load
E = Earthquake Load	R = Rain Load
F = Load due to Fluid	S = Snow Load
F _a = Flood Load	T = Self-Straining Force
H = Lateral Earth pressure Load	W = Wind Load
L = Live Load	

$f_1 = 1$ for floors in places of public assembly, for live loads in excess of 100 pounds per square foot (4.79 kN/m²), and for parking garage live load, and
 = 0.5 for other live loads.

$f_2 = 0.7$ for roof configurations (such as saw tooth) that do not shed snow off the structure, and
 = 0.2 for other roof configurations.

Regardless of the design approach (LRFD or ASD), the load combination that gives the largest value will be the governing load case and should be used to analyze and design the structure.

Looking at the load combinations in the above tables, it is clear that there is little differentiation between the *IBC* and *ASCE 7* load combinations. One of the differences, however, between LRFD combinations is the use of the *f* factor in the *IBC* combinations. One of the major differences though is the factors used in LRFD load combinations versus ASD load combinations. This is because 1) ASD utilizes a safety factor at the end of the design to properly size structural members and account for the potential for overloading and/or material imperfections, and 2) ASD designs members do not exceed their yield strength. LRFD takes a different approach at determining ultimate loads on a member.

The factors associated with each type of load (dead, live, snow, etc.) are based off the probability of that load type exceeding its expected value. For example, when a factor of 1.2 is used for dead loads, it is essentially saying that the dead load can be calculated with 80% certainty. Additionally a resistance factor, Φ , is used to account for any imperfections or understrength of a member. LRFD as a design approach considers both uncertainty and strength separately.

2.8.5 Structural Roof System

The basics of any building's structural system are its foundation, walls or diaphragms, floors and roof. This project specifically targets the analysis of the roofing system of Alumni Gym. The plan for this project was to investigate the feasibility of placing rooftop solar panels on Alumni Gym; doing this would result in increased loading, requiring a structural analysis of the roof members. The roof of a structure serves the purpose of keeping the building as "air tight" as possible, meaning preventing moisture and wind from flowing through the roof and helping maintain a controlled environment inside the structure. The loads that a roof should be designed to carry are dead loads (the weight of the roofing materials and structure), live loads (any operation and maintenance that may occur), wind loads, snow loads, ice loads, seismic loads and rain loads. All of these loads can be applied in various combinations and must be transferred through the walls and down into the foundation.

Commonly, the main supporting system for a roof is trusses. A number of trusses will be spaced along the length of the building, supported typically by the walls, and

additional members will be placed on top to unify the system. Each truss is linked together by members perpendicular to the roof trusses known as purlins, and those are then in filled with a number of roof joists. On top of these joists, sheathing, insulation, and shingles can be placed to complete the roofing system. The framing members span transverse to the top chords of the truss, connecting them to make a unified system. The two figures below display the roof trusses of Alumni Gym. Figure 8 shows a portion of the original blue prints containing the roof truss, and Figure 9 shows the current interior view of the exposed roof members.

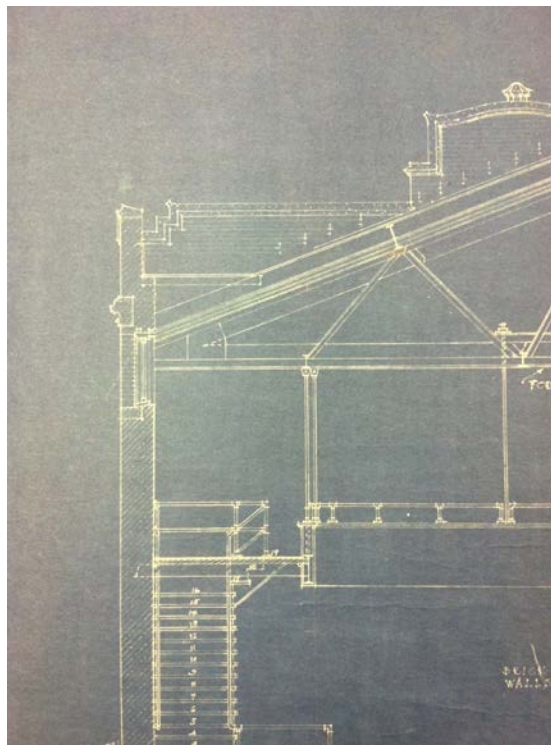

Figure 8: East-West Section Cut (Original Blueprint)



Figure 9: Interior View of Roof Showing Completed Construction

To evaluate the roof of Alumni Gym, there are preliminary steps that must be completed. The section properties of the truss and framing members must be defined as well as the composition of the materials covering the roof. Once properties have been defined, load cases can be generated using the provisions of *ASCE 7-05* and the material properties of the steel and roofing components. Once a governing load case has been identified, the analysis can be performed to ensure that members have the capability to withstand the loadings in terms of strength and also ensure that the roof meets deflection criteria. Additionally, it is important to ensure that the intended load path is maintained, meaning that the roof will still transfer loads through the diaphragms to the foundations. If any changes to the roof were made that resulted in additional uplift forces, it is important to ensure that the roof is properly fixed to the walls of the building.

Chapter Three: Existing Conditions (Phase One)

This chapter presents the methods used and results generated from the analysis of Alumni Gym as it currently stands. Based off visits to the gym and previous BIM models that were created, a new BIM model was generated to accurately portray the geometry and material properties of Alumni Gym appropriate for an energy analysis. This model was exported to *Autodesk Green Building Studio* to generate a life-cycle cost for the facility as well as provide quantitative information on energy use. In order to ensure the model was properly set for energy analysis, certain characteristics, such as providing information for the thermal properties of materials and verifying the airtightness of the building, were necessary. To verify the values calculated by the software and to ensure that these were as accurate as possible, hand calculations of thermal processes and a life-cycle cost analysis were completed using assumptions based off similar projects. Throughout this chapter and the remainder of the report, the analysis of the existing conditions will be referred to as “Phase One” of the project. Overall, this phase was used as a benchmark for comparison.

3.1 Thermal Imaging

Using thermal cameras provided by WPI, exterior and interior thermal images of Alumni Gym were taken. The entire exterior of Alumni was investigated to determine the level of thermal leaks in the building. Each component of the building was analyzed for its thermal efficiency – including windows, doors, and the brick exterior. Based on this investigation, all the masonry showed no signs of heat loss, as the outside temperature and exterior wall temperatures closely matched each other. As seen in Figure 10 below,

there is no bright red color in any locations of the wall, concluding that problem areas were non-existent and heat remained inside the building.

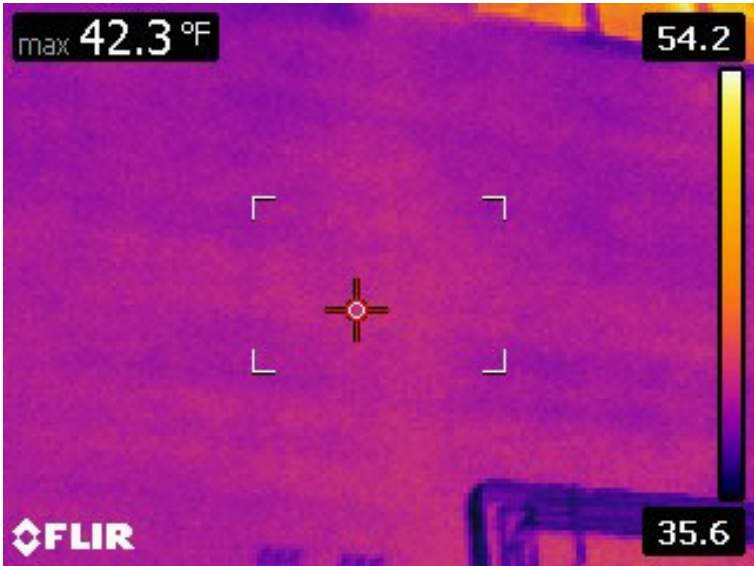

Figure 10: Exterior Wall 10'x 10' view

As assumed, the only problem areas were around the windows. From Figure 11, the “hot spots” or bright red color areas are visible around the exterior of the windows.

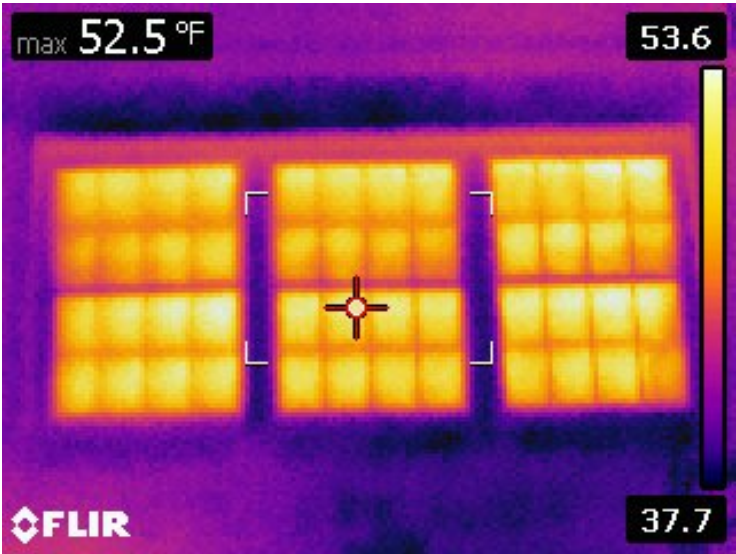

Figure 11: Exterior Windows

Thermal images of the interior of the building also showed no infiltration, excluding the areas surrounding the windows and some doors. Shown below in Figure 12, the dark blue color around the windows indicates that cold air consistently enters the building.

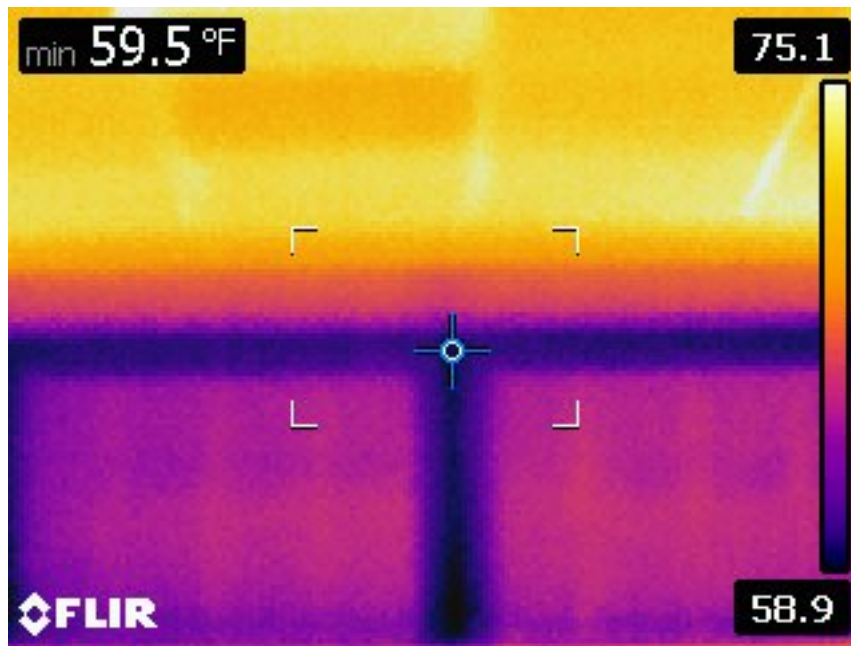

Figure 12: Interior Window

Based on information from the images, the *Revit* model was updated to ensure the windows were single pane, so when the simulation was conducted, it would capture the current conditions.

3.2 Creating the Model

The *Revit* model created for this analysis utilized information provided by two previous models: one produced by John Antonopoulos, Joe Rubino, Ehab Hamden and Michael Potter (Rubino, 2014); another produced by Ray Marquez and Matthew Moreau (CE590A 2010). The information was used to generate a new model that could be exported and analyzed in *Green Building Studio*. The geometry used to create the shell of

the building was based on one of the previous models. This included elevations, dimensions, and the locations of windows and doors. The previous model was designed primarily for structural analysis purposes, so the thicknesses of the walls, dimensions of load bearing walls, and the dimensions of the roof are accurate. The general process for constructing the current model is listed below, and the results can be seen in Figures 13 and 14:

1. Set and define elevations
2. For each level, draw the appropriate walls with the correct material properties and thicknesses. One main assumption made in defining material properties was that actual walls consisted of horse-hair plaster. In *Revit*, there is no material defined as horse-hair, so lime plaster was used in its place, due to its similar thermal properties.
3. In visits to the gym, notes were taken on the materials used on the interior of the walls, the windows (single pane, double pane, etc.), and how the raised portion (clerestory) of the roof appeared to be blocked by plywood. These notes were then applied to the model to improve its accuracy.
4. After the walls were modeled, the floors and roof were inserted. Looking at archived drawings, the materials and layers of these components were confirmed.
5. To complete the exterior of the building, the windows were placed into the walls (host elements). Single pane, casement windows were used and the appropriate dimensions were applied.
6. Using the model from Moreau and Marquez (Moreau, 2010), the interior components, such as the partitions, floors and doors were placed. The materials and thicknesses for these materials were also recorded in site visits.



Figure 13: Exterior Rendering

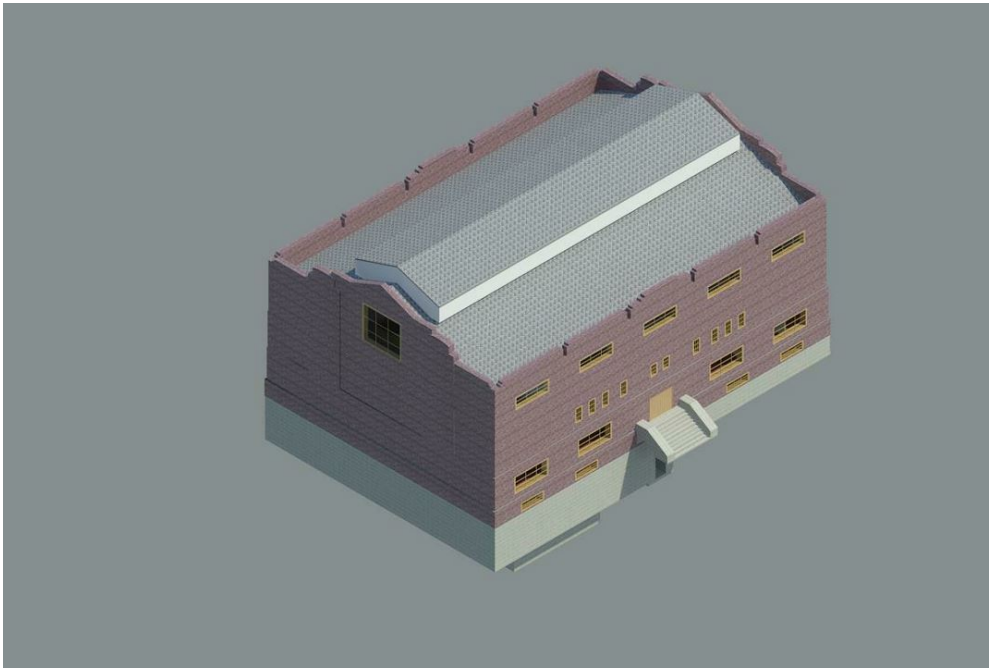

Figure 14: Full Exterior

3.3 Analyzing the Model

After completion of the existing conditions model, it was analyzed for energy use and life cycle cost through the use of *Green Building Studio*. To increase the accuracy of this analysis, all pertinent information was entered, such as the location (Worcester, MA), room locations (spaces), and the type of HVAC system the building uses. Once this information was entered, *Green Building Studio* generated a representation of the life-cycle cost of the building as well as simulating the energy consumption over a 30-year period. The results showed that over a 30-year span, using a discount rate of six percent – the standard for *Green Building Studio* – the total life-cycle cost of the building at net present value would be \$743,536. The full readout from the *Green Building Studio* simulation can be found in Appendix E, including a brief analysis of the readout to roughly check its accuracy.

Since the life-cycle cost value from the *Green Building Studio* did not include the original construction cost of the building or annual operation and maintenance costs, a revised life-cycle cost was calculated, adding this information based on assumptions made by the project team. In addition to the life-cycle cost from *Green Building Studio*, an operation and maintenance cost of \$5,000/year, put into present value over 30 years, and the initial cost of the building, \$81,810 in 1915, adjusted using inflation, was added to increase the 30-year cost to \$2,711,102.28. The 30-year life-cycle cost was then adjusted for 100 years, the lifetime of Alumni, and the total equaled \$9,037,007.61. A summary table of the calculations, detailed in Appendix F, can be found in Table 4 below. The energy costs calculated in *Green Building Studio* were used to analyze the life-cycle

cost because information from WPI facilities was not available at the time the calculation was completed.

Table 4: Calculated life-cycle cost of existing building

LCC from GBS	\$743,536.00
Assumed O&M annual costs	\$5,000.00
Present Value of O&M over 30 years at 6%	\$395,290.00
LCC including O&M over 30 years	\$2,711,102.28
LCC over 100 years of building	\$9,037,007.61
Original cost of building	\$1,572,276.28

3.4 Conclusions

Based on information entered into the *Revit* Model and on the ensuing energy analysis calculations generated by *Green Building Studio*, conclusions can be made about the existing condition of Alumni Gym. First, due to the fact the walls are nearly two-feet thick of brick masonry, there are no areas along the exterior walls where significant, un-proportioned amounts of heat are lost. Second, because this building is over 100 years old, the windows have become weathered and sashing is beginning to deteriorate. The windows are the biggest problem area in the building as they allow the most heat to escape. For this reason, the windows were a major area of focus for both the improvement in the proposed renovations as well as the final recommendations. Other models look to improve upon the current windows in the building and look to find windows that can help the thermal performance.

Chapter Four: Hand Calculation Validation

In this chapter, the conduction value was calculated for exterior aspects of the existing building, including the roof, brick, doors, and windows. In addition to the conduction values, the total number of Therms produced per year by the existing building was calculated. A Therm is a measure of heat energy that is equal to 100,000 British Thermal Units (BTUs). Once this data was collected, it was placed into spreadsheets as a tool to validate the process that was used. Example images of the associated spreadsheets are located in Appendix H. A list of the electronic files and corresponding locations can be found in Appendix N.

4.1 Energy Index Calculations

To begin validating the actual model produced within *Green Building Studio*, industry standard energy intensities were reviewed and compared to the outputs of the simulation done on the Phase One model. The main readout for this validation is the total Energy Use Intensity (EUI), shown in Figure 15 below.

Electricity EUI	7 kWh/sf/yr
Fuel EUI	45 kBtu/sf/yr
Total EUI	70 kBtu/sf/yr

Figure 15: Phase One Green Building Studio Energy Use Intensity

For this model, the total EUI was 70 kBtu/SF/year. The U.S. Energy Information Administration (EIA) publishes tables pertaining to the energy consumption of commercial buildings of different sizes, uses, year of construction, and region of the country, among other categories. The data used was published in 2006 but was collected

for the year of 2003. The latest Commercial Buildings Energy Consumption Survey, for 2012, is only in the preliminary release stage. The tables detailing energy intensity by multiple parameters, known as Table C3, are set to be released in Fall 2015. Below, in Figure 16, is part of the 2003 Table C3 “Consumption and Gross Energy Intensity for Sum of Major Fuels for Non-Mall Buildings, 2003.”

	Number of Buildings (thousand)	Floorspace (million square feet)	Floorspace per Building (thousand square feet)	Total (trillion Btu)	per Building (million Btu)	per Square Foot (thousand Btu)	per Worker (million Btu)
All Buildings*	4,645	64,783	13.9	5,820	1,253	89.8	79.9
Building Floorspace (Square Feet)							
1,001 to 5,000	2,552	6,789	2.7	672	263	98.9	67.6
5,001 to 10,000	889	6,585	7.4	516	580	78.3	68.7
10,001 to 25,000	738	11,535	15.6	776	1,052	67.3	72.0
25,001 to 50,000	241	8,668	35.9	673	2,790	77.6	75.8
50,001 to 100,000	129	9,057	70.4	759	5,901	83.8	90.0
100,001 to 200,000	65	9,064	138.8	934	14,300	103.0	80.3
200,001 to 500,000	25	7,176	289.0	725	29,189	101.0	105.3
Over 500,000	7	5,908	896.1	766	116,216	129.7	87.6

Figure 16: Table displaying average fuel consumption in BTUs based on square footage of buildings (U.S. Department of Energy, 2006).

The important column is the second from the right; the measure of energy intensity in thousands of BTUs per square foot for one year. Alumni Gym, with roughly 35,000 SF, falls into the 25,001 to 50,000 SF range, with an average kBTU/SF/year of 77.6. The other pertinent categories to the existing Alumni Gym in Table C3 are summarized in Table 5 below:

Table 5: Summary of Related Energy Intensities

Category	Energy Intensity (kBTU/SF/Year)
Building Activity: Education	83.1
Building Region: New England	99.0
Predominant Exterior Wall Material: Brick	97.1
Predominant Roof Material: Slate	84.2

Comparing the model's energy intensity to the energy intensity numbers above, it appears that the model output was a little low, but still relatively close to comparable real-life energy usage of similar buildings.

4.2 Methods for Hand Calculations

To further validate the outputs for the simulation of the Phase One Model, hand calculations were performed and compared to the simulation outputs. There are multiple methods for performing hand calculations on a building. One that is applicable is the BIN method, as discussed in personal communication with Professor Kenneth Elovitz (Elovitz, 2015), an adjunct professor in the Civil and Environmental Engineering Department at WPI. In the BIN method, the average maximum, minimum, and constant building temperature must be known. A linear gradient is made between the three temperatures. A heating or cooling load is then calculated for each temperature and is multiplied by the number of hours that each temperature is experienced in an average weather year. Once these calculations are performed, a total amount of energy for heating and cooling can be calculated. While this method would provide a somewhat reliable estimate for the heating and cooling loads, it is an intensive calculation that is often a major portion of graduate level courses and outside the scope of this project. In talking with Professor Elovitz, he agreed that it would be an overly intensive calculation. More detailed descriptions of meetings with Professor Elovitz can be found in Appendix B.

Hand calculations were still performed with a system of checking two major areas of heat loss, conduction and infiltration. However, this method had several limitations in its accuracy. Conduction calculations did not account for internal heat gains that occur

through the normal use of a building. These include heat generated through people, equipment, and interior lighting. Thus, the calculation for heat loss from conduction will be slightly higher than in reality. Infiltration required an assumption on the number of air changes per hour (ACH) that occur in the building from air leaking into the exterior envelope. To more accurately estimate this, two calculations were performed, one with a low air exchange rate and one with a higher air exchange rate. This “bracketed” the results, reflecting uncertainty in the input and providing insight on sensitivity.

4.3 Conduction Calculation

Listed below is a series of steps documenting the process that was used to determine the conduction values for the existing building:

1. Determine the square footage for each window, door, roof section, and brick section throughout the entire building. This information was found using the current *Revit* model.
2. Place into a spreadsheet the total quantity for each component (i.e 60 windows at 15 square feet).
3. Break the building down into its individual components (windows, doors, brick walls, etc.) to allow for accurate calculation of the total heat loss.
4. Look up the U-value for each component in the model. The program determined the U-value based on the material used and the specified thickness.
5. From an online database, determine the average heating degree days (HDD) for each month of the year.
6. Using equation (2) from the background, multiply the U-value by the total square footage to determine the number of BTUs/hr that are produced for each building component. Next, multiply this number by the HDD per month and 24 hours/day to get the correct conversion factor.
7. Convert heat loss calculations to Therms to allow comparison to the *Green Building Studio* output.
8. Complete this cycle for each month and then summarize the information in another table to determine the total Therms.

Initially, an online database was used to retrieve the average high and low temperatures for each month. However, after a meeting with Professor Elovitz, it was determined that using the average high and average low was not a proper way to calculate conduction. This is because the temperature does not stay at the high and low for the entire month, so a different measure of the temperature needed to be used. For this reason, the average heating degree days (HDD) per month provides a more accurate measure.

After all of the information was calculated for the existing phase of the model, the total Therms were compared to the output from *Green Building Studio*. The conduction values calculated by hand for one year, 9,198.56 Therms, were roughly half the number of Therms as the *Green Building Studio* calculation. This may seem very low but since conduction is only part of the heat loss within a building, it appeared to make sense. To fully validate the model, infiltration needed to be calculated as well.

4.4 Infiltration Calculation

Listed below are the steps that were taken in order to determine the infiltration rate for the building as a whole. Following the steps is a more detailed explanation of decisions that were made to determine the infiltration rate.

1. Determine the volume of the building from the current *Revit* model and construction plans for the building.
2. Determine specific heat capacity and density of air as well as heating degree day (HDD) values.
3. Determine Air Changes per Hour value based on comparisons to similar buildings.
4. Multiply the values of each variable together to find the infiltration rate for the building in BTU/h, as shown in Equation 3 in section 2.4.2.

5. Multiply the value by 24 hours/day to account for the hours used for HDD.
6. Divide the calculated value by 100,000 BTU to convert the infiltration rate to Therms.
7. Summarize the results in a table to show the total Therms per month. This is done so the infiltration rate could be combined with conduction and ultimately compared to the value generated by the *Green Building Studio* simulation.

Many variables must be considered in determining the ACH value because it can heavily affect the infiltration rate. Through research, many different values were considered – typically between 2 – 10 ACH. Many studies seemed to place buildings very similar to Alumni at a value of about 3 – 4 ACH (Fennell & Haehnel, 2005). However, some deductive reasoning was used to lower this value. Alumni Gym currently has one main entrance on the south side of the building, so infiltration through the opening of doors is fairly minimal. In addition, the exterior brick has held up throughout its 100-year life, so infiltration through cracks in the walls is also minimal.

The last factor where infiltration could play a major role is in the windows. Through thermal imaging, both inside and outside the building, it was determined that many windows and surrounding areas were very airtight, meaning that air was not entering or leaving the building in large volumes. Through these main reasons, the ACH rate seemed to be minimized, to an estimated value of 0.5 ACH. The building as a whole has a very large volume, so the amount of air entering the building is small when compared to its entire volume. Alumni Gym housed coaches' offices, a basketball court, a running track, and a weight room, among other minor uses. Traffic in the building was relatively low, and since ACH values are rough estimates, a value of 0.5 for the entire building seemed reasonable. Some thermal images are shown below in Figure 17, next to

the actual image of the location. There are no noticeable locations where heat is leaving the building in the images (besides through the window panes, the majority of which is captured within the conduction calculations), as shown by the temperature difference and color gradient.

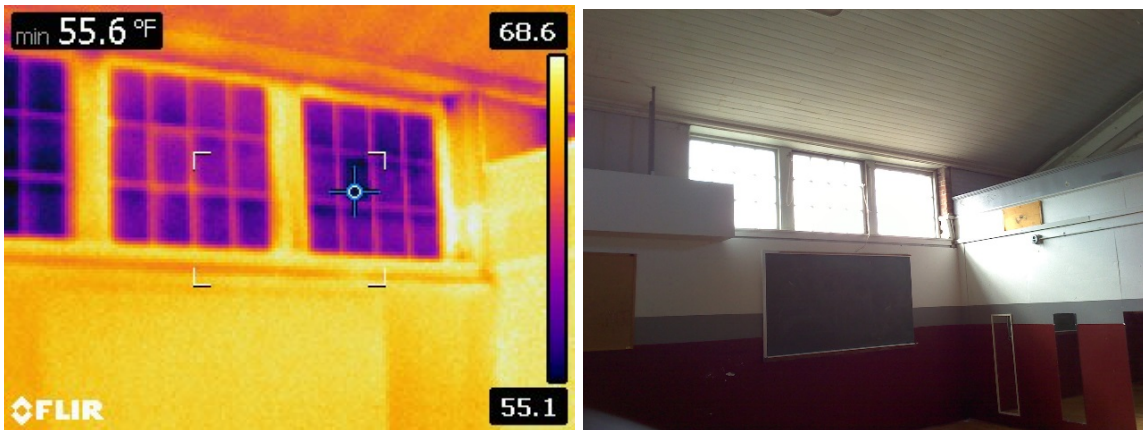
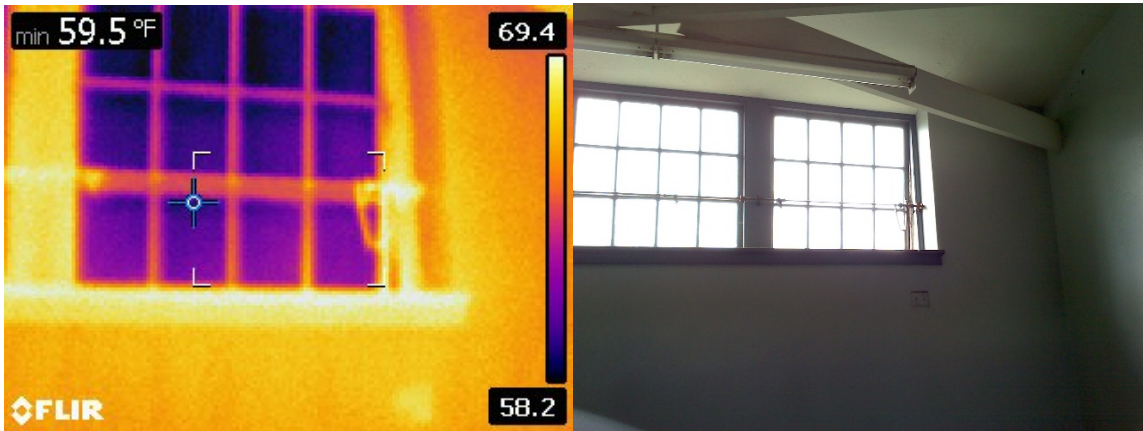

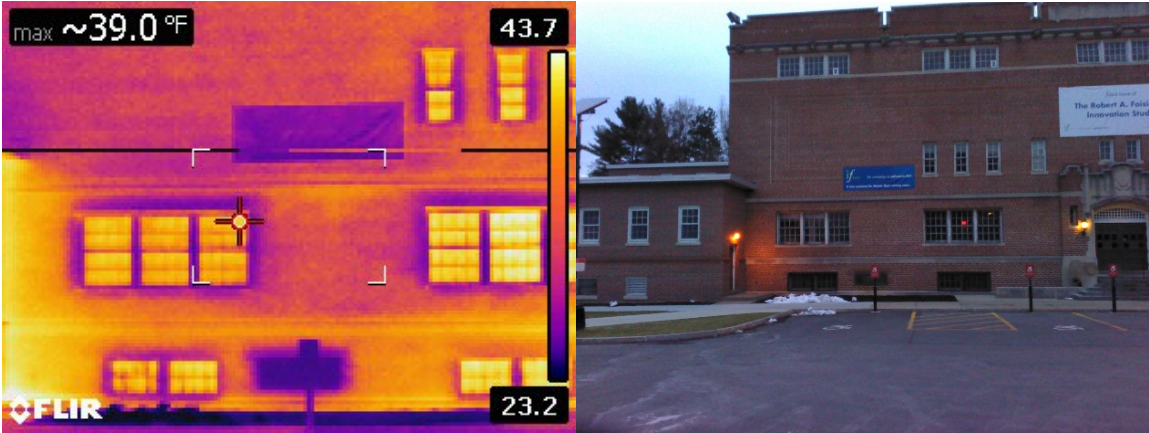

Figure 17: Interior and exterior thermal images of existing Alumni Gym.

Since the air changes per hour plays a large role in the infiltration calculation, calculations were done at an estimated 0.5 ACH, as well as at 2 ACH and 4 ACH to provide a range of results. If 0.5 ACH is used as estimated, then the total heat loss calculated by hand seems to validate roughly the output by *Green Building Studio*. It was expected that the hand calculation would be higher than the output since, as stated, internal heat gains were not accounted for. Table 6 below summarizes the calculated infiltration values.

Table 6: Infiltration Calculations Summary Table

Air Changes per Hour (ACH)	Heat Loss from Infiltration (Therms)	Heat Loss from Infiltration and Conduction (Therms)	30 Year Life-cycle Heat Loss (Therms)
0.5	7878.01	17,076.57	512,297.1
2	31,512.03	40,710.56	1,221,316.8
4	63,024.05	72,222.61	2,166,678.3
Green Building Studio Output			473,324

Chapter Five: Planned Renovations (Phase Two)

This chapter presents the methods used and the results generated from the analysis of the proposed renovation to Alumni Gym. The use of current construction plans, ninety percent drawings, and information generated by the designer were used in order to create a new *Revit* model. The geometric and building components' attribute information shown on the 2D plans were used to create a 3D *Revit* model and exported into *Autodesk Green Building Studio* to determine a life-cycle cost. The goal of generating the second model was to produce a life-cycle cost estimate for the proposed renovations that would be used to measure the improvement from the existing conditions. After these actions were taken, an analysis of the difference in thermal performance between Alumni Gym as it stands and how it is expected to perform after renovations are complete.

5.1 Creating the Model

The model created for this analysis was built from the completed model of Phase One of this project, incorporating information from the detailed design plans created by the architect, Goody Clancy & Associates of Boston. The model created during Phase One of the project was useful because the exterior of the building is relatively untouched during construction. Therefore, the exterior walls of the building were already in place and had the correct dimensions; the interior partitions, staircases, and some windows had to be implemented into the model in order to reflect the current design for the renovation of the building.

Besides the foundation and exterior walls, the entire inside of the building, besides the floors, will be gutted and replaced. In order to place the new partitions, staircases, and windows, knowledge of how to effectively read plans was necessary. Reading these documents required a large amount of time and effort to ensure every detail was captured in the *Revit* model.

After reviewing the renovation plans and completely removing the entire interior of the Phase One model, besides the floor, the new layout for the Phase Two model was placed by starting at the bottom floor (mechanical pit) and methodically working to the top floor. The interior partition schedule was carefully reviewed, making sure all the new partition types were correctly created and placed in the model. Similarly, necessary details were referenced to ensure the floor types and staircases were in the correct locations. Progress continued up from the bottom floor, adding all changes directly as designed by the architect in the construction documents. One difficult aspect of the design was the new entries and main stair on the south side, each involving small platforms or landings that were located between each floor as seen in Figure 18 (this figure does not depict structural supports of cantilevered floors).



Figure 18: South Entry Rendering level three

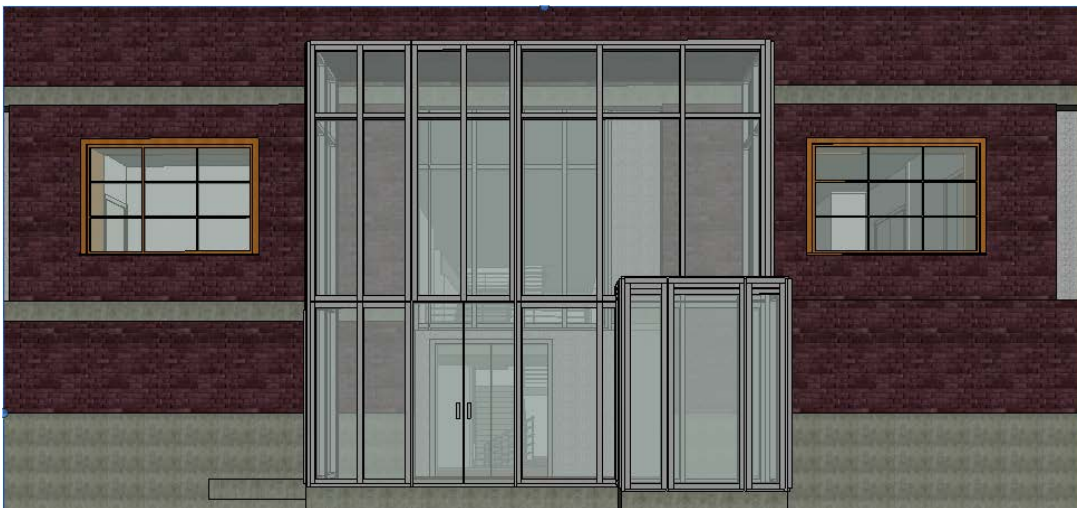

Figure 19: North Entry Rendering

Another method used to provide lighting and architecturally enhance the building is the use of many curtain walls. Although the exterior brick will be untouched by the

planned renovation, the new north entrance has curtain walls which start just above the elevation of floor 2, and extend to the bottom of floor 4, as shown in Figure 19. Both the third and fourth floor contain multiple rooms with all glass entrances similar to the north entrance, requiring extensive placement and adjustment for necessary doors and openings. Figure 20 shows the proposed entry to the Maker Space on the basement floor.

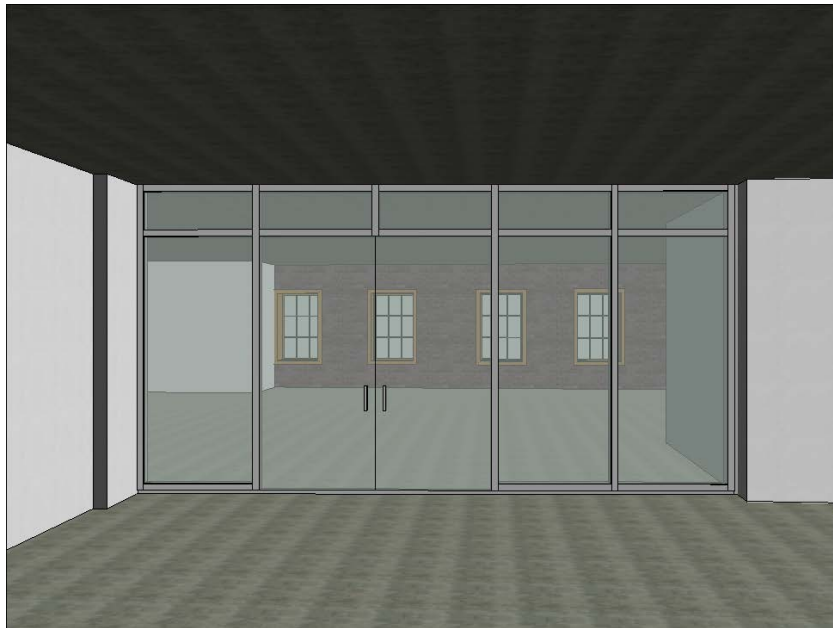

Figure 20: Maker Space Rendering

The last major changes occurred within the windows and the roof of the building. Following design specifications (Goody, 2014), the window panes for all windows in the model were adjusted to match the minimum U-Values and thermal conductivity as specified. This required use of a triple pane, $\frac{1}{4}$ inch thick low-e/low-e/clear glass finish. The interior of the roof is to remain the same as the existing one with pine boards and roof joists. However, the exterior is to be removed and replaced with a vapor barrier, six inches of rigid insulation, $\frac{3}{4}$ inch exterior plywood, and asphalt shingles instead of the existing slate.

5.2 Conclusion

At this point, several options were considered because the Phase Two model was unable to be run through *Green Building Studio*. A more detailed explanation of the troubles encountered with *Green Building Studio* is detailed in Appendix G. The first option was to completely restart with the model from Phase One, running simulations as changes are made to assure that the same error did not occur. The other was to further continue hand calculations, focusing on the major changes to the exterior envelope. Calculating the heat loss through areas such as doors, windows, the exterior shell, and the roof would allow a cost-benefit analysis for the proposed renovations and, more importantly, on any recommendations that would have been tested in Phase Three. Due to time constraints, knowing that the second option could be completed with a higher chance for success, and that there were already hand calculations completed for the validation of Phase One, this option was selected.

From the hand calculations, it was determined that the total number of Therms required to account for the conduction heat loss by the new building was 7,535.15, which is 1,663.41 Therms less than the total required by the existing building. A sample of the spreadsheets used for these calculations can be found in Appendix H. The full spreadsheet is saved as an electronic file with its location detailed in Appendix N. This is a decrease of 18.08% in heat loss due to conduction. The difference in infiltration from one building to the next will add the total difference in Therms. It was concluded that the total heat loss from infiltration would improve slightly due to the proposed windows and doors, but would not make a significant impact because of the new glass entrance. Since the second

model could not be simulated through *Green Building Studio*, knowing the exact value for the infiltration would not provide much insight. A comparison between the hand calculations and *Green Building Studio* was unattainable for the second phase.

In order to gain a better understanding about how this difference in Therms due to conduction would affect the yearly and life-cycle cost of the building, a cost-benefit analysis was completed. Based on a cost estimation completed by the previous MQP group, the new renovation will cost roughly \$9,791,030 (Rubino, 2014). The improvement of 1,663.41 Therms per year translates to a 30 year life-cycle cost savings of \$26,278.20, based on a price of \$1.16 per Therm and a discount rate of 6.1%. While it appears that the benefits of these thermal improvements are strongly outweighed by the cost of the renovation, a majority of the renovation focuses on the interior of the building, leaving a majority of the envelope in its existing condition.

Chapter Six: Potential Thermal Improvements (Phase Three)

Based on the information that the team collected for the first two phases of the project, recommendations were made to further improve the thermal efficiency of the building. Some of these recommendations included changing the proposed double pane windows to triple pane, coating the exterior brick of the building with an Exterior Insulation Finishing System (EIFS) finish, and increasing the six-inch rigid insulation of the roof to eight inches and then twelve inches. After changing these different components in the Phase Two model, hand calculations were completed to determine how much of an improvement each component has on the thermal efficiency of the building. A cost-benefit analysis was then completed to determine the installation cost and compare that value to the total life-cycle cost over a 30-year period. Spreadsheets were used to complete the associated hand calculations. Images of example portions of these spreadsheets are located in Appendix H. The actual electronic files are located online and are listed with their locations in Appendix N. The steps to complete the process are listed below:

1. The total yearly conduction heat losses for the proposed and recommended changes were calculated using the same method as described in Chapter 4: Methods for Hand Calculations.
2. The percentage reduction in heat loss was calculated.
3. The unit cost for the proposed component and the recommended component (cost to furnish and install, based on *R.S. Means Building Construction Cost Data 2014*) (Reed Construction Data, LLC, 2014) and personal communication with industry professionals was determined.
4. The total cost for installation was calculated using the unit cost.
5. The yearly cost in heat loss was calculated based on \$1.16 per Therm.

6. The present value of the total heat loss cost was calculated using the equation below for present value of a standard annuity.

$$P \left[\frac{1 - (1 + r)^{-n}}{r} \right]$$

P = Periodic Payment

r = rate per period

n = number of periods

7. The change in heat loss and its associated costs over the 30-year span was calculated to find the savings in heat loss costs due to the recommendation.

6.1 Triple Pane Windows

As previously stated in the report, the existing building contains all single pane windows. These windows are highly inefficient and allow a large amount of heat loss through conduction. Investigations into whether or not installing triple pane windows would have the same effect as changing from single to double pane were performed (Appendix H); however, the installation cost compared to the life-cycle cost proved that the savings from double to triple pane would not be worth the money. Table 7 below summarizes the calculations made in order to determine the best solution for Alumni Gym.

The important entries in the table below are the comparisons between installation costs and the life-cycle heating cost for the change from single to double pane and for the change from double to triple pane. Based on our calculations, neither improvement will pay off after a 30-year life-cycle from heat loss through conduction. It is also important to note that the increase in heat loss for the proposed double pane windows is due to an increase in number of windows in the renovation.

Table 7: Calculated Heat Loss through the Windows

Recommendation (Improvements)	Heat Loss (Therms)	Percent change	Installation Cost	Life-cycle Heating cost (30 years)
Windows				
Existing Single Pane	1986.9		\$91,305.00	\$31,388.57
Proposed Double Pane (Equal to Existing)	829.5		\$138,658.10	\$13,103.53
Change from Single to Double Pane	1157.4	-58.25%	\$47,353.10	-\$18,285.04
Proposed Double Pane (Including increased area from connector removal)	1523.6		\$254,704.10	\$24,070.15
Recommendation to Triple Pane	1158.0		\$291,090.40	\$18,293.32
Change from Double to Triple Pane	365.7	-24.00%	\$36,386.30	-\$5,776.84

6.2 EIFS Finish

Another characteristic the team looked at as a possible method to increase the thermal efficiency of the building was to coat the entire brick exterior in an EIFS finish. The aesthetics of this option would also need to be considered – the building would lose its current brick exterior look, and it would be the only building surrounding the quadrangle not covered in brick. However, since the installation of additional insulation within the interior is not a viable option due to changes to the dew point of the building that would likely result in damage to the exterior brick, it was decided to calculate what difference insulating from the exterior using EIFS would have. If Goody Clancy & Associates of Boston decided to coat the exterior brick, they would have to factor in the loss of the current brick aesthetics. Summarized below in Table 8 is the total number of

Therms produced and the life-cycle cost for each phase along with a comparison between phases.

Table 8: Calculated Heat Loss for EIFS Finish

Recommendation (Improvements)	Heat Loss (Therms)	Percent change	Installation Costs	Life-cycle cost (30 years)
EIFS Finish				
Proposed Brick Exterior	4325.8		\$0.00	\$68,337.95
Brick Exterior with EIFS Finish	1072.2		\$192,862.18	\$16,938.80
Change from Brick to Brick with EIFS Finish	3253.6	-75.21%	\$192,862.18	-\$51,399.16

Based on the table above, the cost to install the EIFS is much higher than the savings over a 30-year life-cycle. Coupling this with the lost aesthetics of the brick, the EIFS is not worth the thermal savings.

6.3 Increasing the Rigid Insulation

The proposed Foisie Innovation Studio called for a rigid, six-inch insulation on the roof. A recommendation was proposed to add a few more inches of rigid insulation to see if any significant changes were made to the total heat loss of the roof. Options of installing an additional two inches and six inches of insulation were considered. As seen in Table 9 below, the cost for the increased insulation did not outweigh the savings in heat loss and would not be recommended. This final analysis would also need to take into account the feasibility of adding this extra thickness to the roof, and whether or not there would be room below the sheathing and exterior shingles.

Table 9: Calculated Heat Loss through the roof

Recommendation (Improvements)	Heat Loss (Therms)	Percent change	Installation Costs	Life-cycle cost (30 years)
Roof				
Proposed Roof Insulation	590.6		\$17,011.40	\$9,330.03
Increasing to 8" Rigid Roof Insulation	461.1		\$23,919.06	\$7,283.97
Change due to 2" Increase in Rigid Insulation	129.5	-21.93%	\$6,907.66	-\$2,046.06
Increased to 12" Rigid Roof Insulation	319.5		\$34,022.80	\$5,046.95
Change due to 6" Increase Rigid Insulation	271.1	-45.91%	\$17,011.40	-\$4,283.09

The two important rows to note are the change due to 2" increase in rigid insulation and the change due to 6" increase rigid insulation. When the installation costs and the total life-cycle savings from reduced heat loss are compared, neither increase in insulation is worth the initial investment.

6.4 North Entrance Left as Existing Brick

The glass entrance was analyzed to determine the thermal effects of replacing the existing brick wall with a new glass curtain wall. As glass is more thermally inefficient than the thick brick walls, there was actually an increase in heat loss resulting from the proposed entrance. The new glass entrance caused a loss of nearly 600 more Therms. From a thermal efficiency standpoint, the glass entrance does not seem favorable. In reality, due to the design of the entrance with having the wall as a glass curtain wall and an exterior vestibule, this heat loss will be less than that calculated. However, using the simple conduction equations available in the analysis, this was not able to be taken into account. The glass entrance also has non-quantitative value from an architectural and

aesthetic standpoint that was not able to be factored into this analysis. A summary of the calculated heat loss through the glass entry way is presented below in Table 10.

Table 10: Calculated Heat Loss through the new glass entrance

Recommendation (Improvements)	Heat Loss (Therms)	Percent change	Installation Costs	Life-cycle cost (30 years)
Proposed Glass Entrance				
North Side Glass entrance	830.5		\$73,333.26	\$13,120.00
Leave entrance as brick	236.5		\$0.00	\$3,736.58
Total Change	594.0	-251.12%	\$73,333.26	-\$9,383.42

It is important to note with this table that the proposed change through the renovation results in a decrease in energy performance compared to what is existing. Based on this, leaving the building as it is results in the largest cost savings. However, the proposed change is focused more on the aesthetic appeal rather than the thermal performance, trying to create a prominent entrance into the Foisie Innovation Studio on the north side of the building. The hand calculations to determine the heat loss also were limited in taking into account the glass vestibule that extends out from the glass entrance, helping to reduce the amount of heat lost.

Chapter Seven: Structural Analysis for Roof Mounted Solar Panels

One of the major recommendations that is being presented to WPI to further reduce the building's environmental footprint is the installation of rooftop solar panels. This will help offset energy costs of the facility, as well as reduce carbon emissions. Before this can be deemed a realistic proposal, a structural analysis of the roof must be done to ensure that the roof can withstand the added weight and other load effects. The solar panels themselves are relatively lightweight, 3-4 pounds per square foot (PSF), so typically the dead weight of the panels is not an issue. What raises concern is the connection strength of the panels to the roof when high wind and/or seismic activity occur.

To explore this option, a structural analysis of the roof trusses and purlins was conducted for various loading conditions. The trusses in Alumni Gym are spaced every 24'-7" and are comprised of "Double-L" shapes: LL8x6x3/4 (long legs back to back) for the bottom and top chords and LL4x4x3/4 for the truss members. Figure 21 below shows the arrangement of the truss. Steel I-Shaped purlins connect the trusses laterally and also support the roof joists, which are 2" x 10" timbers spaced 16" on center.

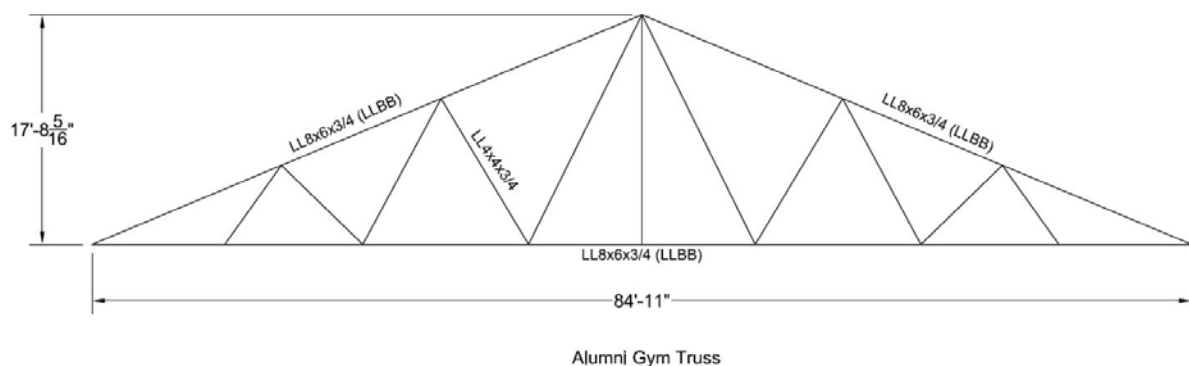

Figure 21: Alumni Gym Truss

7.1 Gathering Loads

All of the loads experienced from the roof and the dead weight of the roof system itself are idealized as point loads acting at the joints of the truss. The dead weight of the roof components including slate tiles, rock wool insulation, plywood, weatherproofing membrane and the roof joists was calculated to be 17.9 pounds per square foot (PSF). Typical PSF values for these materials were found in Table C3-1 of *ASCE 7-05*. The weight of the purlins and the monitor was then calculated and distributed as point loads to the appropriate truss joint. In addition to the dead weight of the roof, snow loads were determined. Using *ASCE 7-05* and the *Massachusetts State Building Code*, the ground snow load for Worcester is specified as 55 PSF. For the sloped roof of Alumni Gym, the roof snow load was calculated to be 38.1 PSF, using *ASCE 7-05*. The roof snow load value gives a more accurate representation of actual conditions, in that the snow load is typically less on the roof than it is on the ground. This is because the snow can get blown off the roof, as well as slide off sloped roofs. Lastly, Chapter 16 of the *International Building Code* specifies for non-occupiable roofs (ordinary, flat, pitched and curved) a minimum roof live load of 20 PSF must be included.

In addition to the gravity loads stated above, lateral loads caused by wind and seismic activity must also be addressed. For wind loads, a spreadsheet provided by F.L. Smidth (F.L. Smidth, n.d.) generated the design wind pressure values for the roof by inputting the applicable values specified in the provision of *ASCE 7-05*, such as basic wind speed, roof slope and exposure category. Table 11 below shows the results for the roof

wind loads and Figure 22 provides a visual definition of windward, leeward and parallel to ridge wind direction.

Table 11: Wind Pressures

Pressures Exerted on the Roof				
Normal to Ridge		Parallel to Ridge	Internal Pressure	
Windward	Leeward		Positive	Negative
Min: -5.0 PSF	Min: -9.0 PSF	Min: -13.6 PSF	3.2 PSF	-3.2 PSF
Max: 2.0 PSF	Max: -9.0 PSF	Max: -2.7 PSF		

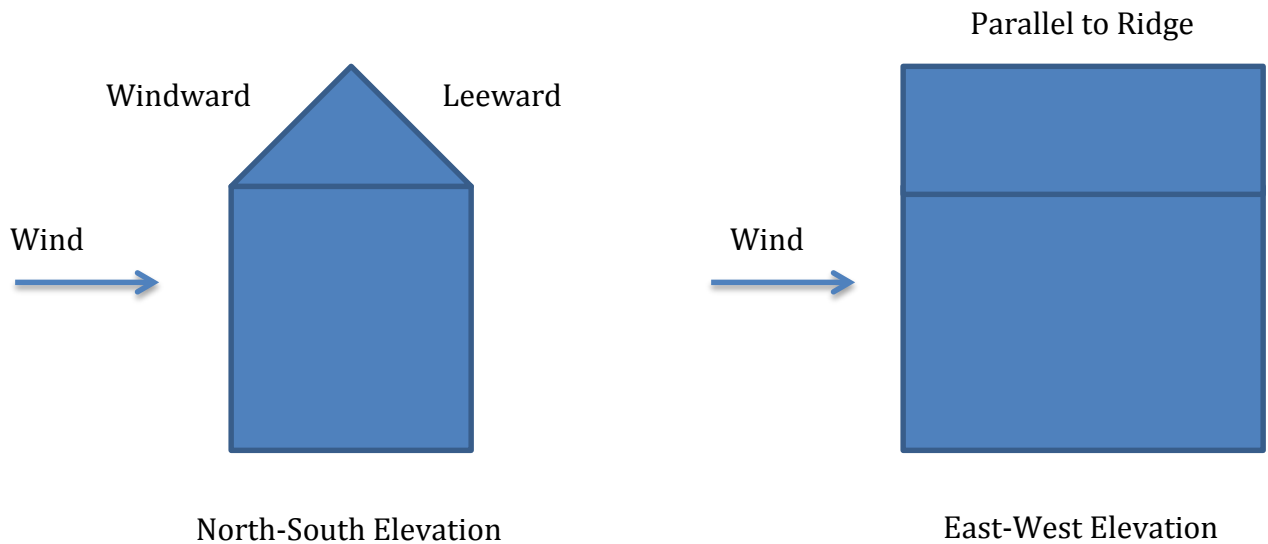

Figure 22: Wind direction definitions

For the seismic loading the weight of the entire structure was calculated in order to determine the seismic base shear, *V*. Using the *Revit* model of Alumni Gym, volumes of the building components could be calculated, and densities provided from *Revit*'s materials library allowed for the conversion to weight. Once the weight was determined

20% of the roof snow load acting on the structure was added. This totaled roughly 18 million pounds. The Equivalent Lateral Force Method outlined in Chapter 12 of *ASCE 7-05* was used to find the seismic force acting on the roof. This force was found to be 415 kips acting on each truss in the North-South direction.

7.2 Analyzing Existing Conditions

Once the loads had been determined, they were then factored using Load Resistance Factor Design (LRFD) to determine the ultimate load case that the structure could experience. Due to the repetitive nature of analyzing each case, *MATLAB* software was coded to analyze two-dimensional trusses using element stiffness matrices, which is the basis of commercial finite element software. Using the *MATLAB* code, axial forces, stresses, displacements, and strain values were all calculated. From this analysis it was found that the largest force placed on the LL8x6x3/4 was 305 kips in compression, which is approximately 71% of the available compressive strength. For the LL4x4x3/4 it was found that the largest stress was 3.1KSI in compression, only 15% of the capacity of the section. The compressive forces placed on the interior members of the truss were small enough in relation to the unbraced length that the axial capacity of the web members were well above the maximum axial loads experienced. The locations of these sections are highlighted in Figure 23 below.

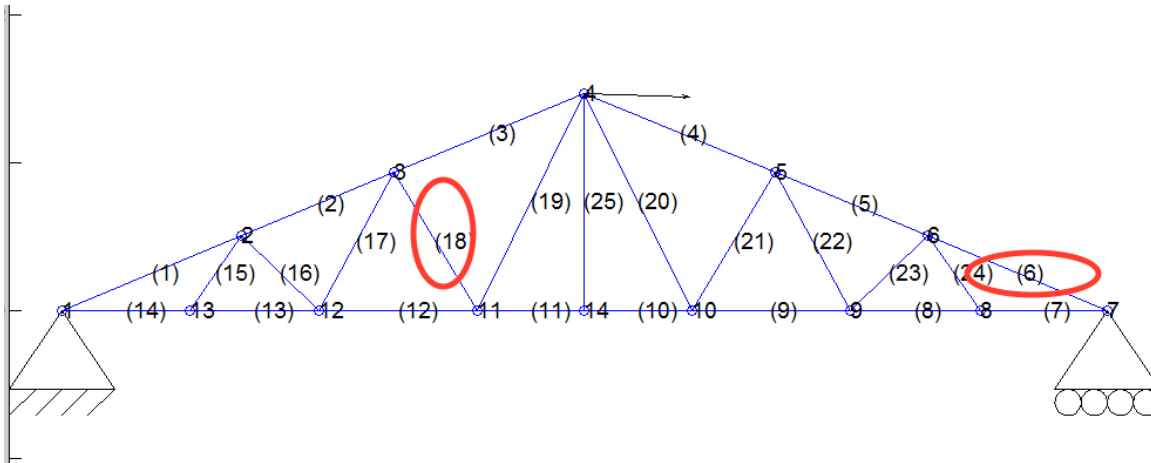

Figure 23: Location of maximum stresses

Similar to the truss members, the roof purlins (S15x42.9 I-Beams) also were well below the capacity of the section. With a simply supported span of 24'-7", the maximum moment of the member is 98.2 ft-kips, 48% of the section's capacity. Hand calculations of the purlins experiencing the existing conditions can be found in Appendix J and the tabulated *MATLAB* can be found in Appendix I.

7.3 Analyzing the Addition of Solar Panels

With the major investigation of this project being how to reduce the environmental impact of Alumni Gym, one of the ways that was explored to do this was placing roof top solar panels. Doing this would inherently result in added stress on the roof members. With the proposed changes to the roofing (replacing slate with asphalt shingles and rock wool insulation with rigid insulation) and an added dead load of 4 PSF for the solar panels, the new dead load acting on the roof members would be 21.9 PSF. This change in the dead load was implemented within the *MATLAB* code, and found that

the truss would be adequate for the increased loading. Maximum stresses for the LL8x6x3/4 and LL4x4x3/4 were calculated as 15.6 KSI in compression and 3.2 KSI in compression, respectively. The I-shaped purlins were also found to be adequate for the increased loading and were found to be at 57% capacity. Supporting calculations for the truss and purlins can be found in Appendices K and K, respectively. By applying the weight of the solar panels across the entire roof and finding that the structure would be adequate, it gave freedom to arrange the panels in various arrangements if desired. For this project, placing the solar panels across the south side roof and monitor was explored. The arrangement would allow for a minimum of 4 feet of clearance of the parapet walls for installation and maintenance purposes.

To calculate the design uplift forces induced by the solar panels, *ASCE 7-05* was again used. A report written by professional engineers Stephen Barkaszi and Colleen O'Brien from the Solar America Board for Codes and Standards (Barkaszi & O'Brien, 2010) outlined the approach and thinking behind analyzing photovoltaic (PV) arrays for wind and provided the basis of calculating the maximum uplift force. The arrangement of a flush mount PV array (PV array having the same angle of the roof slope) could be considered as an open structure allowing the use of an internal pressure coefficient, GC_{pi} , of zero PSF. It is suggested though by Barkaszi and O'Brien, that a conservative GC_{pi} value of +/- 0.3 PSF be used. Using a conservative approach to ensure that the panels can withstand maximum uplift, pressures experienced at the edges were used across the entire array. Using this approach it was found that the maximum expected uplift force on

the solar panels is 28.4 PSF. Calculations to arrive at this value can be found in Appendix M.

It was also necessary to investigate the seismic forces that the solar panel arrays might experience. Using Chapter 13 of *ASCE 7-05*, information relating to the design of nonstructural components, a lateral force value of 11 LBS per panel needed to be designed for. Hand calculations for this value can be seen in Appendix M. This value was factored into the design of the connections that will now be explained.

Looking further into how the solar panels are typically mounted to a rooftop to withstand uplift and lateral forces, there are two main components: supporting rails and base mounts. A typical detail for the solar panel connection is provided in Figure 24 below; the typical roof section view of the solar panel is shown in Figure 25. For this project two manufacturers of PV array mounting products were examined, *QuickMount PV* (Quick Mount PV, 2015) and *Ironridge* (Ironridge, 2015). *QuickMount PV* provides a variety of products but one product in particular was analyzed for the addition of solar panels to Alumni Gym. The *QBase Composition Mount* is suggested for use on asphalt shingled roof systems for flush mount PV arrays.

This space has been intentionally left blank

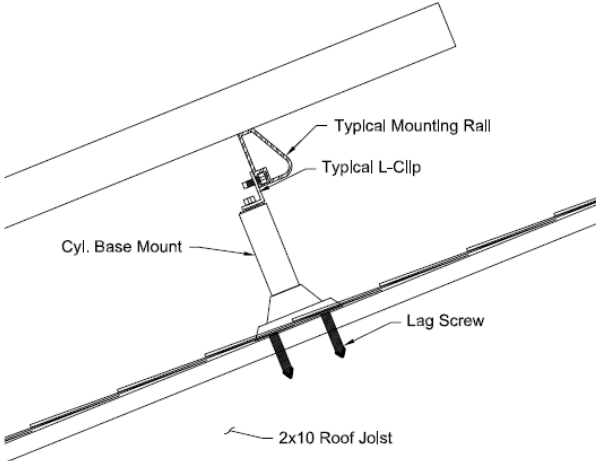
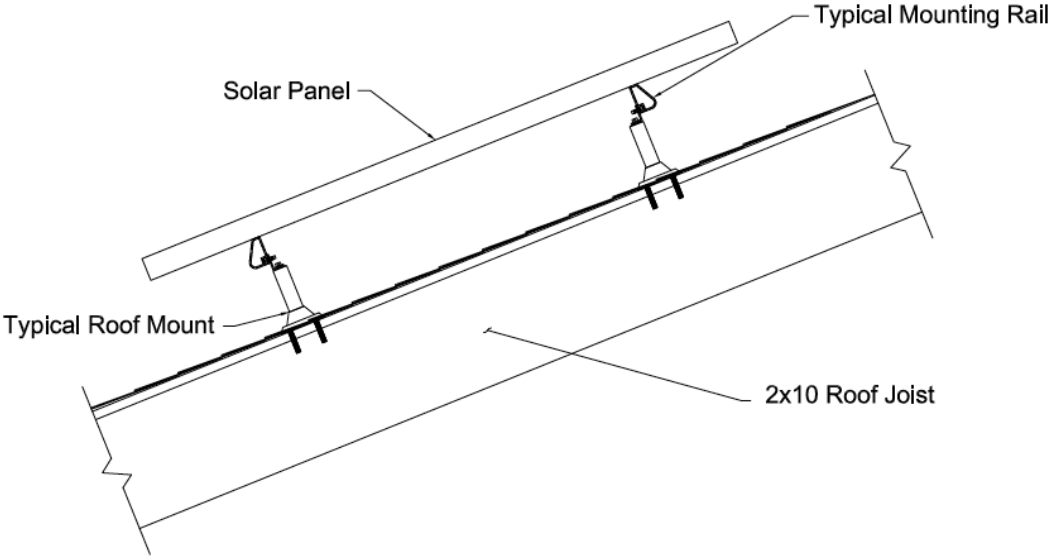

Figure 24: Typical Connection Detail



Roof Section With Solar Panel

Figure 25: Roof Section with Solar Panel

The *QBase Composition Mount* is composed of a cylindrical piece that is bolted to the roof, a sheet metal cover or flashing that is laid under the shingles for weather proofing, and a bolt at the top that hold the L-shaped clips that attach to the support rails. For this particular product, an engineering report of the pullout strength and shear strengths of the mount is provided (Faiyaz & Tajirian, 2011). From tensile testing it was found that the *QBase* could withstand a pullout force of roughly 3000 lbs. and shear force of roughly 1400lbs, which is sufficient from analyzing the uplift and lateral forces acting on the array. With the high strength of the connection, very few mounts would be required, but the span of the support rails would likely be too long to support the loads of the solar panels.

After examining the solar panel mounts, it was necessary to examine the support rail system. For this, a mid-grade product, manufactured by *Ironridge* was used. The *XR100* rail is made of 6000 series aluminum making it lightweight and easily machined or formed. To determine the spacing of the supports for these rails, the maximum moment capacity of the section was determined (0.795 ft.-Kips) and used to back solve for the span length. From this, a maximum span length of 8'-0" was calculated. However this span length would result in a deflection of 2.25", which could result in stresses added to the panel and cause cracking or other damage to the system. From this it was necessary to reduce the span length further. Typical allowance for interior floor deflections (with span lengths greater than 30') is a maximum of 1" to help prevent the cracking of windows and partitions, so a conservative limit of ¼" of deflection was used because of the brittle

materials within the photovoltaic cells. From this deflection limit, the minimum span length of the rails was calculated to be 4'-6". Hand calculations for the investigation of the support rail system can be found in Appendix M. Figure 26 below gives a plan view of the PV array and its supports.

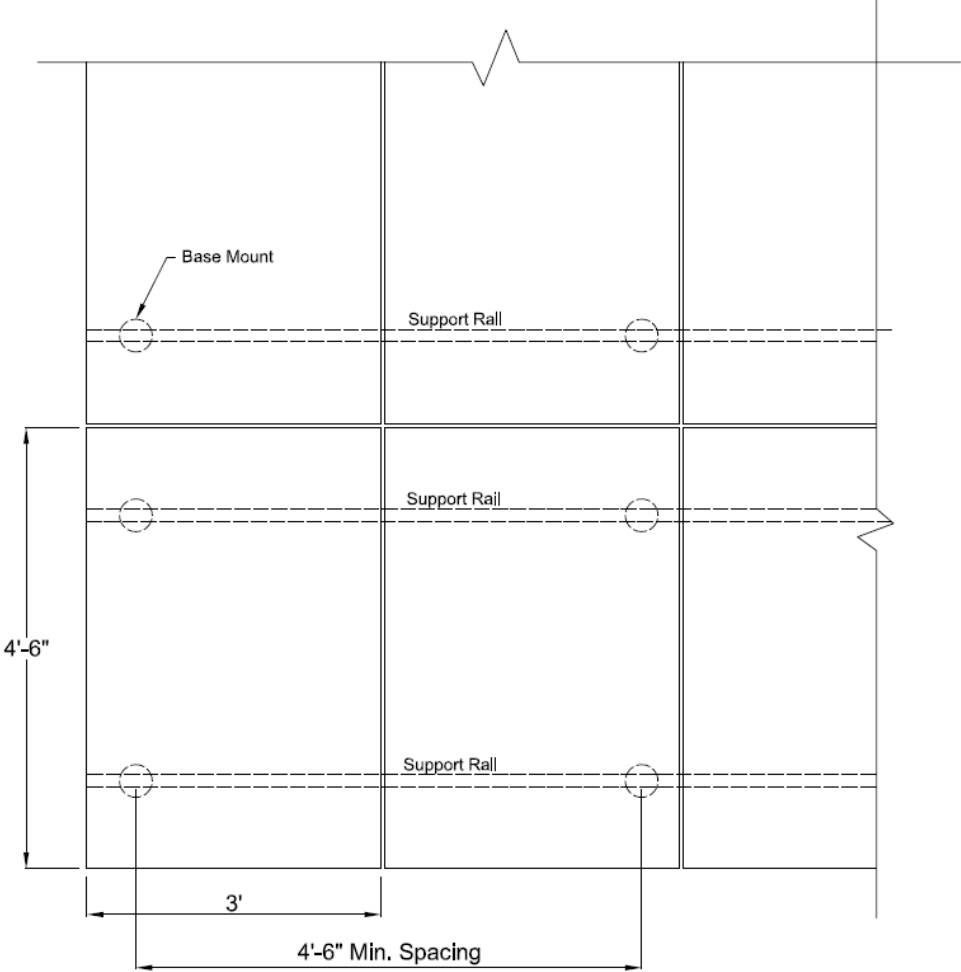

Support Spacing

Figure 26: PV Array Support Spacing

Once the connection details were determined, it was recommended to use one row of thirty-five, 3'-0" x 4'-6" solar panels for the monitor roof, and four rows of thirty-five solar panels along the main roof. Both sets of panels would be located on the south side roof with a layout similar to the one depicted in Figure 27 below. This gives a total of 175 solar panels, covering approximately 2,360 SF.

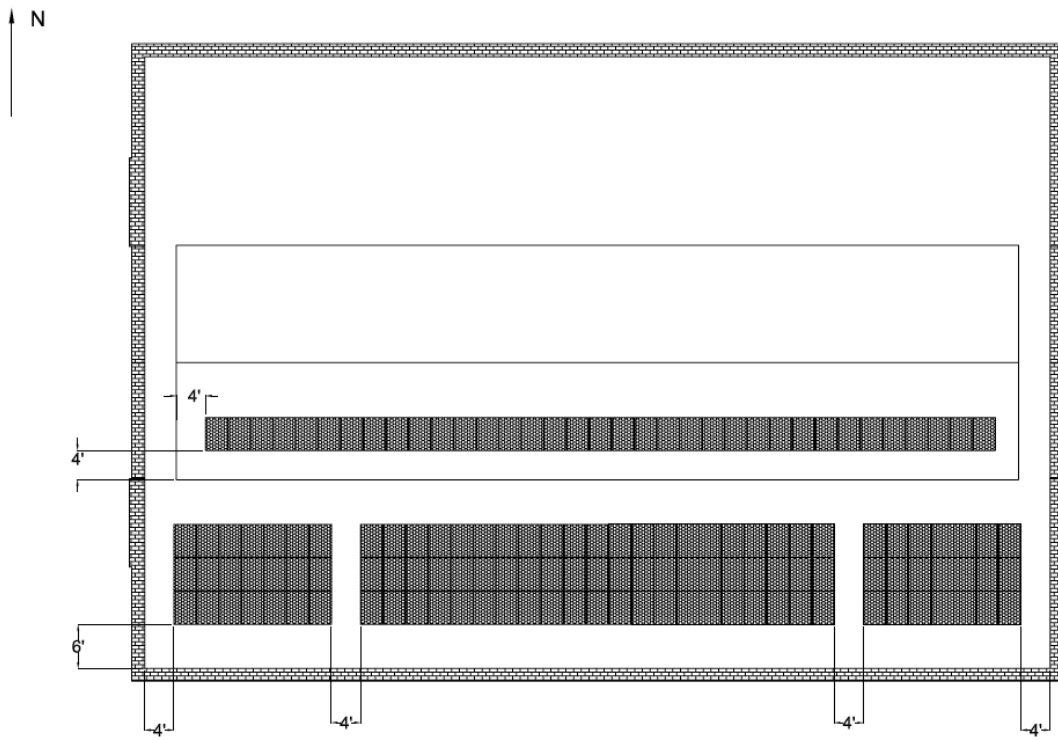

Plan View of Roof with Solar Panels

Figure 27: Proposed Solar Panel Arrangement

7.4 Conclusion

After analyzing the existing roof structure and looking further into the added effects of solar panels on the roof system, it was found that the roof is adequate to support the addition of solar panels. Using the above stated base support spacing of 4'-6", the PV array's would be expected to resist the maximum wind and seismic forces (in addition to dead and snow loads) as specified by *ASCE 7-05* without failure.

Using the suggested array layout shown in Figure 27, the expected electricity generation would be on the order of 455,766 kWh per year. This would translate into energy savings of approximately \$63,800 per year.

Chapter Eight: Conclusions and Future Work

After completion of this project, there were several conclusions made about the thermal efficiency of the existing, proposed, and recommended building. First, Alumni Gym as it currently stands is highly inefficient. There is a large amount of heat loss through the windows, doors, and roof. One strong thermal component of Alumni Gym is the masonry. Investigations using thermal cameras and hand calculations on conduction and infiltration values proved the brick was thermally efficient and did not need any renovation. Secondly, the proposed design from Goody Clancy & Associates of Boston showed a much more thermally efficient building. The double pane windows, new doors, and added insulation to the roof decreases heat loss as compared to the existing building. A cost benefit analysis helped determine how much the building saved by installing these new components. Lastly, recommendations were made to determine the potential impact of any further improvements. Characteristics, such as going from double to triple pane windows, removing the glass entrance, and increasing the amount of rigid insulation were all analyzed. The completion of conduction and infiltration hand calculations and then performing a cost benefit analysis showed that these improvements cost more to install than the benefit they return. It was determined that the proposed building design from Goody Clancy & Associates of Boston was the most thermally efficient building analyzed during the project.

Currently, there are on-going discussions in regards to the future of Alumni Gym. The Board of Trustees at WPI is tasked with two choices for the building: leave the existing building and renovate the interior creating the Foisie Innovation Studio, or demolish

Alumni Gym and pursue new construction options. If decided that the best use of the space would be to demolish Alumni Gym and pursue new construction, the scopes of possible future projects would vary from this project. However, if the Board of Trustees decides to continue with the renovation, there is potential for future projects which could include more of a project management aspect due to the fact that construction would occur. The project could investigate a schedule for the construction and renovation. Looking into where improvements could be made to the schedule, and where phases of construction can be completed quicker than were originally anticipated could be aspects of the project.

A project that could be implemented if Alumni Gym is demolished, would be working with every phase of the new building construction. The project could investigate work through the design, bidding, schedule, and the construction phase of the new building. Similar to the current project, a new team could investigate ways the new building could become LEED certified and as energy efficient as possible. Additionally if Alumni Gym was torn down, various structural systems could be investigated for feasibility purposes, such as precast versus cast-in-place concrete.

Works Cited

- ASCE. (2014). Retrieved October 11, 2014, from American Society of Civil Engineers : http://www.asce.org/uploadedFiles/Ethics_-_New/Code%20of%20Ethics%20October%202010.pdf
- Autodesk. (2015). *Calculating the Conductive Heat Gain*. Retrieved from <http://help.autodesk.com/view/RVT/2014/ENU/?guid=GUID-6D3C2737-2810-42DE-894E-0A6B5DE24EE6>
- Autodesk. (2015). *Construction*. Retrieved from <http://knowledge.autodesk.com/support/green-building-studio/learn-explore/caas/CloudHelp/cloudhelp/2014/ENU/Revit/files/GUID-4E91A2A4-ED44-4D49-ACFC-D7636571AB3E-htm.html>
- Autodesk. (2014, July 1). *Green Building Studio Validation*. Retrieved from Autodesk Green Building Studio: <http://knowledge.autodesk.com/support/green-building-studio/learn-explore/caas/CloudHelp/cloudhelp/ENU/BPA-GBSWebService/files/GUID-EF68E7D5-C0A5-4805-BFE5-7C74C57B712E-htm.html>
- Autodesk. (2014, July). *Green Building Studio Validation*. Retrieved from Autodesk Green Building Studio: <http://knowledge.autodesk.com/support/green-building-studio/learn-explore/caas/CloudHelp/cloudhelp/ENU/BPA-GBSWebService/files/GUID-EF68E7D5-C0A5-4805-BFE5-7C74C57B712E-htm.html>
- Autodesk. (2015). *Heating and Cooling*. Retrieved from <http://help.autodesk.com/view/RVT/2014/ENU/?guid=GUID-45C16A16-EF62-4341-B190-F7458C5B83C6>
- Autodesk. (2015). *Heating and Cooling*. Retrieved from <http://help.autodesk.com/view/RVT/2014/ENU/?guid=GUID-D88E8A06-6E08-4CD6-89A0-368A2AD6C03C>
- Autodesk. (2015). *How Whole Building Energy Simulation Works*. Retrieved from http://help.autodesk.com/view/BUILDING_PERFORMANCE_ANALYSIS/ENU/?guid=GUID-30BE9353-50D0-4EA9-83C3-B40F74721A29.
- Autodesk. (2010). *Sustainable Building Design Software*. Retrieved September 30, 2014, from autodesk.com: <http://usa.autodesk.com/ecotect-analysis/>
- Azhar, S., & Brown, J. (2009). BIM for Sustainability Analyses. *International Journal of Construction Education Research*.
- Barkaszi, S., & O'Brien, C. (2010). *Wind Load Calculations for PV Arrays*. Solar America Board for Codes and Standards.
- Bergman, T., Dewitt, D., Incropera, F., & Lavine, A. (2011). *Fundamentals of Heat and Mass Transfer*. Hoboken: John Wiley & Sons, Inc.
- Bowman, M. (n.d.). Air Change Rates. Jacksonville, Florida, United States of America: Florida State College at Jacksonville.
- Choosing a Well-Insulated Window*. (2011). Retrieved from <https://www.energyguide.com/info/window2.asp>

- Elovitz, K. (2015, February). Conduction and Infiltration Calculation Review. (G. Kornichuk, Interviewer)
- Epstein, E. (2012). *Implementing Successful Building Information Modeling*. Boston, MA: Artech House.
- F.L. Smidth. (n.d.). MWFRS Wind Loads.
- Faiyaz, M., & Tajirian, A. (2011). *Composition Mount Load Testing*. Applied Materials & Engineering, Inc.
- Fennell, H. C., & Haehnel, J. (2005). Setting Airtightness Standards. *ASHRAE Journal*, 26-30.
- Firefighting Applications*. (2014). Retrieved from P&R Infrared: <https://www.pr-infrared.com/about-thermal-imaging/firefighting-applications>
- FLIR i3/i5/i7*. (2014). Retrieved from FLIR: <http://www.flir.com/cs/emea/en/view/?id=41963>
- FLIR. (2014). *Thermal Imaging Cameras For Border Security and Coastal Surveillance*. Retrieved 2014, from FLIR: <http://www.flir.com/cs/emea/en/view/?id=42102>
- Getting to know LEED: Building Operations and Maintenance (O+M)*. (2014). Retrieved from <http://www.usgbc.org/articles/getting-know-leed-building-operations-and-maintenance-om>
- Gevorkian, P. (2012). *Large Scale Solar Power Systems: Construction and economics*. Retrieved from <http://library.books24x7.com.ezproxy.wpi.edu/assetviewer.aspx?bookid=50214&chunkid=871987616>
- Gleeson, J. (2008). *Computer-Aided Green Design*. Retrieved September 22, 2014, from Architecture Week: http://www.architectureweek.com/0330/tools_1-2.html
- Goody, C. &. (2014, September 22). Conceptual Design Progress Set. Worcester, Massachusetts.
- Hensley, J. E. (2011). *Improving Energy Efficiency in Historic Buildings*. Retrieved from <http://www.nps.gov/tps/how-to-preserve/briefs/3-improve-energy-efficiency.htm>
- Holliday, M. (2011). *Insulating Old Brick Buildings*. Retrieved from <http://www.greenbuildingadvisor.com/blogs/dept/musings/insulating-old-brick-buildings>
- Hong, T., Wang, C., Yan, D., & Zhu, D. (2012). *Comparison of Building Energy Modeling Programs: Building Loads*. Ernest Orlando Lawrence Berkeley National Laboratory.
- Ironridge. (2015). *Roof Mounting System Engineering & Design Guide*.
- Judkoff, R., & Neymark, J. (2006). *Model Validation and Testing: The Methodological Foundation of ASHRAE Standard 140*. Quebec City.
- Kats, G., Alevantis, L., Berman, A., Mills, E., & Perlman, J. (2003). The Costs and Financial Benefits of Green Buildings. *A Report for California's Sustainable Building Task Force*.
- LEED for Schools*. (2013). Retrieved from 1. <http://www.usgbc.org/leed/rating-systems/schools>

- LEED. (2014). *Getting to know LEED: Building Operations and Maintenance (O+M)*. Retrieved from <http://www.usgbc.org/articles/getting-know-leed-building-operations-and-maintenance-om>
- Lott, M. (2011). *Guest Post: LEED – Not just a pretty plaque, and certainly not perfect*. Retrieved from <http://blogs.scientificamerican.com/plugged-in/2011/10/06/guest-post-leed-not-just-a-pretty-plaque-and-certainly-not-perfect/>
- Moreau, M. (2010). *Alumni Gym*.
- National Oceanic and Atmospheric Administration. (n.d.). *Questions about Heating, Cooling Degree Days*. Retrieved from National Weather Service of Cleveland, Ohio: <http://www.erh.noaa.gov/cle/climate/info/degreedays.html>
- New FLIR E-Series and E-Series bx. (2014). Retrieved from FLIR: <http://www.flir.co.uk/instruments/display/?id=56911>
- Olbina, S., & Reeves, T. (2012). *Validation of Building Energy Modeling Tools: Ecotect, Green Building Studio, and IES*. Gainesville: University of Florida.
- Quick Mount PV. (2015). *QBase Composition Mount*. Retrieved from Quick Mount PV.
- Reed Construction Data, LLC. (2014). *RS Means Building Construction Cost Data*. Norwell.
- Rubino, J. (2014). *Alumni Gym MQP 2013-2014*.
- Ruder, D. B. (1997, September 11). *Barker Center Dedicated Tomorrow*. Retrieved from The Harvard University Gazette: <http://news.harvard.edu/gazette/1997/09.11/BarkerCenterDed.html>
- Sefaira Fulcrum. (2014, August). *Sefaira Fulcrum & ASHRAE Standard 140-2011*. Retrieved from Sefaira: <file:///C:/Users/Greg/Downloads/Sefaira%20Fulcrum%20Validation%20Testing%202014.pdf>
- Shawmut Design and Construction. (1997). *Harvard University Barker Center for the Humanities*. Retrieved from Shawmut Design and Construction: http://www.shawmut.com/our_work/project-datasheets/acad-acadbld-hu-barker-data.pdf
- Smith, D., & Tardif, M. (2012). *Building Information Modeling a Strategic Implementation Guide for Architects, Engineers, Constructors, and Real Estate Asset Managers*. Chichester: John Wiley & Sons.
- Southface Energy Institute. (2011, March). *Blower Door and Duct Leakage Testing for Duct & Envelope Tightness Verification*. Atlanta, Georgia, United States of America: Southface Energy Institute.
- The Daily Herd. (2014, January 6). *Alumni Gym*. Retrieved from The Daily Herd: <http://wp.wpi.edu/dailyherd/2014/01/06/alumni-gym/>
- Thermography Proves Energy Efficiency of Post Frame Buildings*. (2013, August 29). Retrieved from Hansen Buildings: <http://www.hansenpolebuildings.com/blog/wp-content/uploads/2013/08/thermal-image-home.jpg>
- U.S. Department of Energy. (2011). *Air Leakage Guide*. U.S. Department of Energy.
- U.S. Department of Energy. (2011, January). *DOE Sponsored Tools - Building Energy Simulation Tests*. Retrieved from http://apps1.eere.energy.gov/buildings/tools_directory/doe_sponsored_bestest.cfm

- U.S. Department of Energy. (2006, December). *Table C3. Consumption and Gross Energy Intensity for Sum of Major Fuels for Non-Mall Buildings*. Retrieved from U.S. Energy Information Administration:
http://www.eia.gov/consumption/commercial/data/archive/cbecs/cbecs2003/detailed_tables_2003/2003set9/2003html/c3.html
- Worcester Polytechnic Institute. (2013). *A Dynamic Expression of the WPI Plan*. Retrieved from https://my.wpi.edu/bbcswebdav/pid-367679-dt-content-rid-1803312_1/courses/MQP-LDA1501-A14-D14/WPI_11x17%20layout_011613.pdf
- Worcester Polytechnic Institute. (2012). *WPI Sustainability Plan*.

Appendix A: Project Proposal



An Energy Analysis of the '56 Foisie Innovation Studio

A Major Qualifying Project
Submitted to the Faculty of
Worcester Polytechnic Institute
In partial fulfillment of the requirements for the
Degree of Bachelor of Science
In Civil Engineering

Zach Blanchard Gregory Kornichuk, Taylor
Landry, John McGonagle

Abstract

This project will analyze the energy efficiency of Alumni Gym in three different phases: the existing conditions, the proposed renovation, and the proposed recommendations. Thermal imaging and Building Information Modeling utilized to complete this energy analysis. Some of the recommendations may include modifications to insulation, windows, and the addition of solar panels. A Life-cycle cost assessment will also be completed in order to determine the feasibility of the proposed changes. Based on this Life-cycle cost assessment, final recommendations will be made to WPI.

Authorship

Throughout this proposal, the team members provided equal contributions in research and writing. Thus, all team members deserve equal credit as authors. Details regarding the specific contributions of each student during this Major Qualifying Project (MQP) follow.

Zach Blanchard focused on the Capstone Design Experience. In addition, he was the main author of the Thermal Imaging and Thermal Analysis sections of the background.

Greg Kornichuk focused on the Introduction and Design Problem. He also was the main author on the Current Status of the Building section of the background and co-authored the first three sections of the methodology.

Taylor Landry concentrated on the Building Information Modeling section of the background. Furthermore, he was co-author of the first three methodology sections as well as the main author of the Structural Analysis section of the methodology.

John McGonagle was the main author of the Energy Sustainability section of the background and the Life-Cycle Assessment section of the methodology.

Although sections of the report have primary authors, each section received multiple team edits. Our team worked together in an equitable and cooperative atmosphere to produce the final product.

Capstone Design Experience Statement

Upon completion, this Major Qualifying Project (MQP) will have integrated capstone design experience. Below is a discussion on the design problem of the project, our team's approach to the design problem, and how the ABET General Criterion Eight Realistic Constraints will be addressed.

Design Problem

The need and desire for green construction continues to grow with the world's increased focus on the environment. A major part of green construction is the design and building of a structure that is as energy efficient as possible. In the US, residential and commercial buildings account for 40% of total energy consumption (U.S. Department of Energy, 2014). A major portion of this energy consumption in buildings, roughly 48%, is from heating and cooling (U.S. Department of Energy, 2014). As a result, many contractors and clients want their projects to be certified sustainable with a large focus on thermal efficiency. In March 2000, the U.S. Green Building Council unveiled the LEED (Leadership in Energy and Environmental Design) green building certification system, a system certifying commercial, institutional, and residential buildings for their exceptional environmental and health performance. By 2011, there were a total of 10,000 commercial LEED certified buildings. The five major criteria for certification are: sustainable sites, water efficiency, energy and atmosphere, materials and resources, and indoor environmental quality (LEED Certification Information, 2014).

Worcester Polytechnic Institute is no exception in striving towards sustainability when renovating and constructing new buildings on its 150-year-old campus. The previous four buildings that have been constructed have all been certified sustainable,

achieving different levels of LEED Certification. The latest project occurring on WPI's campus is the renovation of Alumni Gym, which will create a new space for student collaboration on group projects and showcase previous WPI innovations and achievements. While this renovation may not be submitted for LEED certification, there is potential for the design, construction process, and the building operations to align with WPI's values of energy efficiency and environmental sustainability.

Scope of Work

This project will use Building Information Modeling (BIM) and thermal imaging technology to analyze the building's thermal performance and provide recommendations for potential improvements. Three different stages will be investigated: the thermal performance of the existing building as a benchmark, the thermal performance as expected based on the current design for the renovation, and potential thermal performance based on recommendations proposed by the students' project. Areas of significant thermal losses in the existing building will be identified and any possible improvements will be tested using BIM software analysis. Installation of renewable energy solutions will also be investigated to reduce the overall environmental impact of the new renovation. All possible solutions will be analyzed for performance, constructability, monetary costs, and construction schedule efficiency.

In order to investigate the three different stages stated above, BIM models would be created at different phases in the process to identify differences and find any improvements to the building's environmental footprint. First, a BIM model of the building's current performance with no proposed changes will be created. Next, a second

model will be created using the current construction documents to reflect the building's predicted performance. Lastly, a series of BIM models with proposed improvements from the project team will be created to determine the effect these proposed changes will have on the building's energy efficiency.

Approach

To determine how efficient the building currently is, an updated BIM model must be created to show Alumni Gym at its current state. To do this, a model from a previous MQP group will be taken and an interior fit out will be completed in order to make sure the model is exactly the same as Alumni. This will make sure the tests are as accurate as possible. The model currently available to the group reflects the envelope of the building, the current structural components, and some additional components that were suggested by the previous MQP, but it does not include any interior members, rooms, etc. We will add material types, correct thicknesses, and various irregularities so the tests are precise. This information will be coupled with old building blueprints to completely update the model to reflect the current state of Alumni Gym.

Using *Autodesk Revit* and *Green Building Studio*, we will conduct a full thermal efficiency test with information from our thermal cameras to pinpoint air gaps or discontinuities in the building. Although the program is accurate in testing for a completely closed building, we will add gaps identified by thermal cameras that may affect heat flow to produce accurate results. Using heat transfer equations, the actual amount of heat loss for selected rooms within the building can be calculated through the use of thermal imaging. These can be used to ensure that the models are consistent with

field data. Thermal imaging also allows the team to identify problem areas in the existing building.

After the model is tested and the data is taken, the model will be updated with the proposed construction plans to determine the efficiency of the building as it is predicted. Again, a test will be conducted from the BIM model. Once this data is compiled and analyzed using *Revit* and *Green Building Studio*, it can be compared to the benchmark performance and a percentage change will be calculated. The team can compare specific areas of change, which will impact cost estimates, and recommendations can be made on these new conditions. However, thermal imaging will most likely not be able to help the team in this phase. Construction is scheduled to start in March of 2015, which suggests that it will be unlikely for the team to be able to analyze the renovated building using thermal imaging.

After this second model is tested, recommendations will be made by the team in ways thought to make the building more efficient. Next, a series of models will be created to individually and collectively determine the effectiveness of these recommendations. These proposed changes will be analyzed for their change in performance versus changes in cost, embodied energy, constructability, and impacts to the construction schedule. Depending on the proposed solutions, a structural analysis may be necessary to ensure the building's structural integrity is maintained. This stage will contain results from multiple BIM models so the team will be able to pinpoint exactly which recommendations are worthwhile.

The final step in the project is the Life-cycle cost analysis. This will help the team determine if the proposed changes are worthwhile when compared to initial costs. This will serve as a cost-benefit analysis of each change to determine which solutions will give the greatest return on investment. Three Life-cycle cost tests will need to be completed for the three main phases of the project: the existing structure before construction, proposed changes from the current design team, and the building with our team's recommendations. After all three have been completed, the team will be able to clearly identify which designs will provide the lowest cost of ownership, while still staying consistent with the quality and function of the building.

Realistic Constraints

There are eight ABET General Criterion Realistic Constraints which should be addressed in completing a Major Qualifying Project. The constraints that will be addressed in this MQP are: economic, environmental/sustainability, manufacturability, ethical, health and safety, social, and political.

Economic

The cost of a construction project is usually a major constraint for all involved in the design, construction, and completion. Estimates and budgets aim to keep the cost of projects in check. Renovations can especially be difficult due to the uncertainty and unknown factors that might exist in the old building. The project team will closely consider these costs when making recommendations due to the tight budget that WPI has made for this project. The team will search for energy efficient solutions that do not greatly affect the overall cost of the project. To help ensure that the project is not exceeding the

overall budget, the team will prepare a full cost estimate for the renovation and any recommendations.

There are multiple aspects of the project that are outside the scope of our knowledge and expertise. These include the mechanical, electrical, and plumbing aspects of the renovation. These will have to be estimated based on a square foot cost basis. The team will also have to take in to account that the cost estimates rely heavily on simulations done on the models. Determining which solutions have the higher benefit to cost ratio depends on the performance increases that the model determines. The models will take certain assumptions into account and cannot be guaranteed to exactly reflect the real conditions.

Sustainability

WPI has recently made a movement towards constructing buildings in a more environmentally friendly and energy efficient way. The focus of this project is rooted in trying to create a more sustainable and energy efficient building. The project will focus on the thermal performance of the new renovation and analyzing possible solutions that can help increase the thermal performance. The better the thermal performance of the building, the less energy the building will require to operate. The more energy efficient the building the smaller overall environmental impact the building will have, striving towards a more energy and environmentally friendly building.

Every aspect proposed in the new design was analyzed for environmental and energy efficiency. Also, a thermal analysis will be completed on the building to determine problem areas that could potentially be altered to reduce the environmental footprint.

Manufacturability

All of the proposed changes made to Alumni Gym will be addressed for their constructability as seen in the three BIM Models. These models provide a 3D visual into how each of the new structural components affects the overall design of the building. For example, when placing the solar panels on the existing roof, a structural analysis will be completed to determine whether or not the current structure could maintain the added weight provided by mounting the panels. Multiple structural alternatives will be considered based on their constructability. A cost-benefit analysis will be completed on each of these alternatives to determine which ones are the best suited and most cost effective for WPI.

Ethical

With this project there will be associated ethical constraints. During the beginning stages of the project the team signed a confidentiality agreement release to ensure that we keep information regarding the plans of the building and past information confidential. Another ethical constraint that will come into play is when we begin the structural analysis of the roof. It is our responsibility to ensure that our results are accurate and the appropriate building codes are withheld to help protect the general public. Any results that suggest the structure may be in violation of the building code would require us to address and resolve the issue.

Health & Safety

In general this project will have multiple areas where health and safety are a priority. ASCE Canon 1 states: Engineers shall hold paramount safety, health and welfare of the public and shall strive to comply with the principles of sustainable development in

the performance of their professional duties (ASCE, 2014). Another aspect that must be considered when making recommendations for the Foisie Innovation Studio is that the campus will still be in operation. This means that delivery and placement of materials must account for the flow of students through the “wind tunnel” to and from the quadrangle and ensure that students remain safe and relatively unaffected by the construction of the facility. Any solutions the project team recommends will account for the health and safety of the public.

Social

Since this project is in the middle of a college campus, the surrounding environment must be taken into consideration. With construction vehicles and delivery trucks constantly coming to the building, many people will be troubled when traveling in areas around the Innovation Studio. Also, the purpose and designs of the building have been finalized, meaning different stakeholders have received certain areas of the building (robotics pit, tech suites, offices, etc.). We must take these factors into account when preparing our recommendations because we cannot undermine any areas of the building that would take away from different groups on campus.

Political

Alumni Gymnasium is considered a historical building because it is over 100 years old. In transforming it into the Foisie Innovation Studio, it cannot lose its historical value. This means that our team cannot make improvements that would make a substantial difference to its appearance in accordance with the law set by the state of Massachusetts

Table of Contents

Abstract.....	86
Authorship.....	87
Capstone Design Experience Statement.....	88
Design Problem.....	88
Scope of Work.....	89
Approach.....	90
Realistic Constraints.....	92
Economic.....	92
Sustainability.....	93
Manufacturability.....	94
Ethical.....	94
Health & Safety.....	94
Social.....	95
Political.....	95
Chapter One: Introduction.....	97
Chapter Two: Background.....	99
2.1 Energy Sustainability.....	99
2.2 Building Information Modeling (BIM).....	103
2.3 Thermal Analysis.....	107
2.4 Thermal Imaging.....	109
2.5 Current Status of Building.....	112
Chapter Three: Methodology.....	116
3.1 Analysis of Existing Building.....	116
3.2 Analysis of Planned Renovation.....	118
3.3 Analysis of Possible Improvements.....	119
3.4 Structural Analysis.....	121
3.5 Life-cycle cost.....	122
Works Cited.....	125

Chapter One: Introduction

In recent years, there has been a large societal growth in environmental consciousness. Words such as “green” and “sustainable” are constantly in the headlines and are major topics of discussion for politicians, product development, and construction. The fear of climate change has resulted in new research and developments that focus on reducing energy consumption and the production of greenhouse gases. With residential and commercial buildings accounting for roughly 40% of total energy consumption in the US (U.S. Department of Energy, 2014), the construction of buildings is a major focus for trying to reduce the overall amount of energy used. New techniques and materials for the construction and performance of buildings are constantly being utilized in an attempt to reduce the overall impact that buildings have on the environment.

Of that 40% of energy consumed, 48% is attributed to the heating and cooling of the building during operation. Newly constructed buildings are designed with a large focus on reducing the cost of operation to try and save the client money they will spend to run the building and to reduce the overall impact of the building on the environment. These environmental issues become even more of a problem when dealing with renovations of old buildings.

Buildings built around the turn of the 20th century were often constructed using brick and mortar. At this time in society, little focus was placed on the environmental impacts of buildings. These buildings were built strong to last but are often very inefficient from an energy standpoint. This project focuses on these environmental challenges in

renovations for Alumni Gym, built in 1915 in the center of Worcester Polytechnic Institute's campus.

Alumni Gym has recently lost its original use as a gym and recreation center due to the completion of the new WPI Sports and Recreation center in 2012. The building has sat dormant for two years now with access closed off to students and faculty. The building is now set to be renovated and repurposed as the Foisie Innovation Studio, a building housing multiple disciplines and work areas. With any renovation, there are several areas of importance that must be addressed. This includes a structural analysis to assure the building is safe and up to current codes. The next area is the interior design to update old mechanical, electrical, and plumbing structures as well as interior partitions, changing the layout of the building to fit the new use. Lastly is the energy and environmental performance of the newly renovated building. Environmental standards are much higher in modern times. WPI prides itself in building "green" and sustainable buildings, as showcased through the LEED certification of the two most recently built buildings.

This project will use Building Information Modeling (BIM) and thermal imaging technology to analyze the buildings current thermal performance. Areas of significant thermal losses will be identified and any possible improvements will be tested using thermal and BIM software. Installment of renewable energy solutions will also be investigated to help reduce the overall impact of the new renovation. All possible solutions will be analyzed for performance, constructability, monetary costs, and construction schedule costs.

Chapter Two: Background

The latest renovation on Worcester Polytechnic Institute's campus, Robert A. Foisie Innovation Studio at Alumni Gym, will present multiple challenges to the designers and construction managers due to the buildings age. Alumni Gym has stood atop the WPI campus for over a century. The new design and renovation will have to modernize the interior, upgrading all structural, mechanical, electrical, and plumbing systems up to assure Worcester Building Code compliance. The challenge in this project is that much of the old building, including the main structural components and exterior envelope will be remaining to retain the historic character of the building. This will make interior work more selective and difficult. It also brings into importance the thermal efficiency of the building. Energy sustainability affects both the environment and the overall operating costs of the building, making it a big point of discussion in modern times.

2.1 Energy Sustainability

Historic landmarks and buildings constructed over 100 years ago have withstood the test of time. Thick masonry walls prove these structures were built to last rather than built for environmental efficiency. One advantage of these walls, although not intended during design, is they manage temperature control as the thickness keeps the heat in during the winter and the cold in during the summer. Also, the windows allow buildings to take advantage of the natural sunlight. However, most of these buildings need renovating because they are no longer used for their original purpose and the working parts of the building are outdated. More energy efficient technology is available to update these buildings to the 21st century.

Since the turn of the century, the need to construct buildings in a more energy efficient and environmentally sustainable way has increased significantly. Over-consumption of natural resources is a serious problem that cannot be ignored. Structures built in the early 1900s that still stand today are usually not demolished because it would cost less, use less resources and conserve more energy to renovate than demolish (Hensley, 2011). It can take nearly 80 years to break even with the environmental impact of demolishing an old building and erecting a new one (Getting to know LEED: Building Operations and Maintenance (O+M), 2014). However, there are alternative solutions to help reduce their environmental footprint. Some of these alternatives include: mounting solar panels on roofs, installing low water consumption toilets and faucets, improving exterior insulation, upgrading existing windows and window locations, and setting up a recycling system. These aspects can help an old building achieve Leadership in Energy and Environmental Design (LEED for Schools, 2013), which is the standard for more energy and environmentally efficient structures.

In striving for more environmentally sustainable buildings, many modern building designs aim for their structure to operate at zero-net energy. This means that the building incorporates renewable energy and sustainable practices that nullify any energy it consumes. One main way for a building to produce its own renewable energy is through the use of solar panels.

Solar Panels utilize photovoltaic cells to convert light energy into a usable source of electricity. By mounting these devices on roof tops, the amount of fossil fuels a building uses is significantly reduced if a building is dependent upon electricity for heating, cooling

and other utilities. Solar panels offer a return on investment between 6-15 years depending on the type of panel, the wattage output, how many panels are installed and how much sunlight the panels receive daily (Gevorkian, 2012). However, often times these panels are very large and provide added weight that an existing roof structure may not be able to sustain safely. The amount of dead load, the constant load on a structure, which is produced by the panels, could be dangerous for occupants of the building. Engineers must complete a structural analysis for roofs before the solar panels can be mounted. Once an engineer determines the roof can support the additional weight, the panels can be installed. Solar panels are one way a structure can work towards LEED certification.

Another aspect a building can incorporate when trying to achieve energy and environmental sustainability is the use of thermal insulation. As previously mentioned, most old buildings use thick walls as their main source of insulation. While these are effective, there are better solutions that have evolved over time. However, these brick structures can be extremely difficult to insulate on the interior due to the fact that the bricks get cold in the winter and placing insulation over these bricks will not allow the moisture from the warm inside air to escape and therefore the bricks rot. The best way to insulate these old brick buildings is to insulate from the exterior using a layer of rigid foam cover with synthetic stucco. Also, insulating the windows of these old buildings will help achieve a more energy efficient building.

When windows are not insulated properly, they allow heat to pass through rather easily. This is troublesome in the winter as the heat that was supposed to warm up a

room, escapes through the windows. Also, poorly insulated windows will allow condensation build up because similar to the walls of a brick building the moist indoor air comes in contact with the cold window, thus leaving water residue on the trim. To test how well a window's insulation performs, a person would need to check the U- and R-value. These two values measure the thermal conductivity of a window. They are inverses of each other, so $U = 1/R$ (Choosing a Well-Insulated Window, 2011). Having new windows that properly regulate temperature within a building is another step towards LEED certification.

The LEED standard is aimed at reducing energy costs and pollution, as well as conserving resources such as energy, water, and recyclables. LEED certification gives recognition to buildings that strive towards environmental sustainability. These certified buildings serve as icons in a community, helping to elevate the community's standard for energy efficiency. In order for a building to receive LEED certification it has to receive a specific number of points. These points are awarded based on criteria that LEED has established. LEED focuses on sustainable sites, water efficiency, energy and atmosphere, materials and resources and indoor environmental quality when giving points towards certification. Figure 1 outlines the criteria for receiving these points.

LEED 2009 for New Construction and Major Renovations			Project Name
Project Checklist			Date
Sustainable Sites		Possible Points: 26	Materials and Resources, Continued
<input type="checkbox"/>	Prereq 1	Construction Activity Pollution Prevention	<input type="checkbox"/>
<input type="checkbox"/>	Credit 1	Site Selection	<input type="checkbox"/>
<input type="checkbox"/>	Credit 2	Development Density and Community Connectivity	<input type="checkbox"/>
<input type="checkbox"/>	Credit 3	Brownfield Redevelopment	<input type="checkbox"/>
<input type="checkbox"/>	Credit 4.1	Alternative Transportation—Public Transportation Access	<input type="checkbox"/>
<input type="checkbox"/>	Credit 4.2	Alternative Transportation—Bicycle Storage and Changing Rooms	<input type="checkbox"/>
<input type="checkbox"/>	Credit 4.3	Alternative Transportation—Low-Emitting and Fuel-Efficient Vehicles	<input type="checkbox"/>
<input type="checkbox"/>	Credit 4.4	Alternative Transportation—Parking Capacity	<input type="checkbox"/>
<input type="checkbox"/>	Credit 5.1	Site Development—Protect or Restore Habitat	<input type="checkbox"/>
<input type="checkbox"/>	Credit 5.2	Site Development—Maximize Open Space	<input type="checkbox"/>
<input type="checkbox"/>	Credit 6.1	Stormwater Design—Quantity Control	<input type="checkbox"/>
<input type="checkbox"/>	Credit 6.2	Stormwater Design—Quality Control	<input type="checkbox"/>
<input type="checkbox"/>	Credit 7.1	Heat Island Effect—Non-roof	<input type="checkbox"/>
<input type="checkbox"/>	Credit 7.2	Heat Island Effect—Roof	<input type="checkbox"/>
<input type="checkbox"/>	Credit 8	Light Pollution Reduction	<input type="checkbox"/>
<input type="checkbox"/>	Credit 4	Recycled Content	1 to 2
<input type="checkbox"/>	Credit 5	Regional Materials	1 to 2
<input type="checkbox"/>	Credit 6	Rapidly Renewable Materials	1
<input type="checkbox"/>	Credit 7	Certified Wood	1
Water Efficiency		Possible Points: 10	Indoor Environmental Quality
<input type="checkbox"/>	Prereq 1	Water Use Reduction—20% Reduction	<input type="checkbox"/>
<input type="checkbox"/>	Credit 1	Water Efficient Landscaping	2 to 4
<input type="checkbox"/>	Credit 2	Innovative Wastewater Technologies	2
<input type="checkbox"/>	Credit 3	Water Use Reduction	2 to 4
<input type="checkbox"/>	Prereq 1	Minimum Indoor Air Quality Performance	<input type="checkbox"/>
<input type="checkbox"/>	Prereq 2	Environmental Tobacco Smoke (ETS) Control	<input type="checkbox"/>
<input type="checkbox"/>	Credit 1	Outdoor Air Delivery Monitoring	1
<input type="checkbox"/>	Credit 2	Increased Ventilation	1
<input type="checkbox"/>	Credit 2.1	Construction IAQ Management Plan—During Construction	1
<input type="checkbox"/>	Credit 2.2	Construction IAQ Management Plan—Before Occupancy	1
<input type="checkbox"/>	Credit 4.1	Low-Emitting Materials—Adhesives and Sealants	1
<input type="checkbox"/>	Credit 4.2	Low-Emitting Materials—Paints and Coatings	1
<input type="checkbox"/>	Credit 4.3	Low-Emitting Materials—Flooring Systems	1
<input type="checkbox"/>	Credit 4.4	Low-Emitting Materials—Composite Wood and Agrifiber Products	1
<input type="checkbox"/>	Credit 5	Indoor Chemical and Pollutant Source Control	1
<input type="checkbox"/>	Credit 6.1	Controllability of Systems—Lighting	1
<input type="checkbox"/>	Credit 6.2	Controllability of Systems—Thermal Comfort	1
<input type="checkbox"/>	Credit 7.1	Thermal Comfort—Design	1
<input type="checkbox"/>	Credit 7.2	Thermal Comfort—Verification	1
<input type="checkbox"/>	Credit 8.1	Daylight and Views—Daylight	1
<input type="checkbox"/>	Credit 8.2	Daylight and Views—Views	1
Energy and Atmosphere		Possible Points: 35	Innovation and Design Process
<input type="checkbox"/>	Prereq 1	Fundamental Commissioning of Building Energy Systems	<input type="checkbox"/>
<input type="checkbox"/>	Prereq 2	Minimum Energy Performance	<input type="checkbox"/>
<input type="checkbox"/>	Prereq 3	Fundamental Refrigerant Management	<input type="checkbox"/>
<input type="checkbox"/>	Credit 1	Optimize Energy Performance	1 to 19
<input type="checkbox"/>	Credit 2	On-Site Renewable Energy	1 to 7
<input type="checkbox"/>	Credit 3	Enhanced Commissioning	2
<input type="checkbox"/>	Credit 4	Enhanced Refrigerant Management	2
<input type="checkbox"/>	Credit 5	Measurement and Verification	3
<input type="checkbox"/>	Credit 6	Green Power	2
<input type="checkbox"/>	Credit 1.1	Innovation in Design: Specific Title	1
<input type="checkbox"/>	Credit 1.2	Innovation in Design: Specific Title	1
<input type="checkbox"/>	Credit 1.3	Innovation in Design: Specific Title	1
<input type="checkbox"/>	Credit 1.4	Innovation in Design: Specific Title	1
<input type="checkbox"/>	Credit 1.5	Innovation in Design: Specific Title	1
<input type="checkbox"/>	Credit 2	LEED Accredited Professional	1
Materials and Resources		Possible Points: 14	Regional Priority Credits
<input type="checkbox"/>	Prereq 1	Storage and Collection of Recyclables	<input type="checkbox"/>
<input type="checkbox"/>	Credit 1.1	Building Reuse—Maintain Existing Walls, Floors, and Roof	1 to 3
<input type="checkbox"/>	Credit 1.2	Building Reuse—Maintain 50% of Interior Non-Structural Elements	1
<input type="checkbox"/>	Credit 2	Construction Waste Management	1 to 2
<input type="checkbox"/>	Credit 3	Materials Reuse	1 to 2
<input type="checkbox"/>	Credit 1.1	Regional Priority: Specific Credit	1
<input type="checkbox"/>	Credit 1.2	Regional Priority: Specific Credit	1
<input type="checkbox"/>	Credit 1.3	Regional Priority: Specific Credit	1
<input type="checkbox"/>	Credit 1.4	Regional Priority: Specific Credit	1
Total		Possible Points: 110	

Figure 1: Example LEED Certification criteria list. (Lott, 2011)

There are a total of 110 possible points that a building can earn towards becoming LEED certified. There are four different levels of LEED certification that can be achieved. They are: Certification (40-49 points), Silver (50-59 points), Gold (60-79 points), or Platinum (80-110 points) (LEED for Schools, 2013).

2.2 Building Information Modeling (BIM)

As it was touched upon earlier, one of the biggest challenges that the construction industry faces is maximizing the efficiency of operations and limiting the amount of

resources required to complete a project. In a study conducted by the Construction Industry Institute, it was estimated that in 2004, 57% of construction spending was waste, which is the equivalent of over \$600 billion (Smith & Tardif, 2012). Figure 2, below, puts the amount of construction materials in perspective by comparing materials/products from several different industries (Smith & Tardif, 2012).

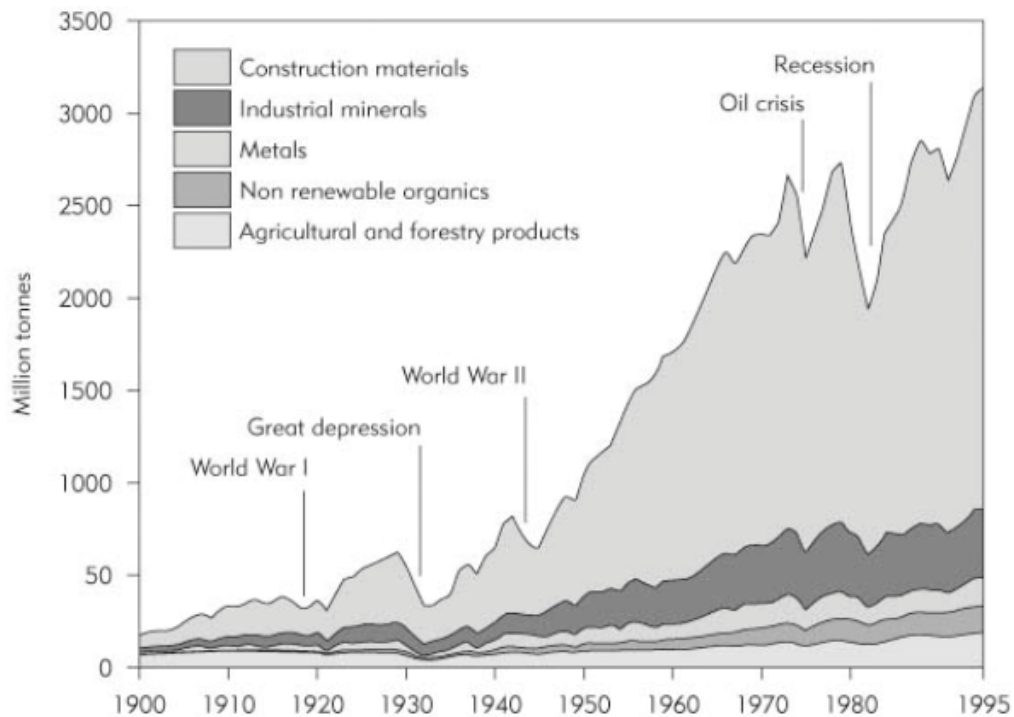

Figure 2: Material Usage (Smith & Tardif, 2012)

This figure suggests that the amount of materials being consumed for construction is increasing at a much faster rate in comparison to other industries. This is one reason why the construction industry has seen a large push towards sustainable design and construction. One of the ways that the construction industry has begun to mitigate the waste of materials is through the implementation of Building Information Modeling (BIM) (Smith & Tardif, 2012).

Building Information Modeling is much more than creating visually appealing designs for clients and owners. It creates a line of communication between all parties involved on the project. BIM allows multidisciplinary information to be superimposed into one model, allowing parties to be more involved and in tune. Some of the tasks that BIM can provide are quantity takeoffs, energy analyses, schedules, clash detections, and material lists (Epstein, 2012). These tasks can be performed quickly and with greater accuracy, saving time and money. Although licensing fees can give the initial impression that “it may not be worth it” to utilize these technologies, studies have shown that increasing the upfront costs (roughly 2% for sustainable design) results, on average, in 20% savings of the total construction costs over the project’s life cycle (Kats, Alevantis, Berman, Mills, & Perlman, 2003).

Today, there are many companies that do use BIM. However, these companies often rely on BIM to only get them through the design and construction of the project. Some of the most significant savings can occur when BIM is utilized through the life cycle of the facility. When the BIM model is used to its full potential, facility managers have the ability to look the model and quickly find information versus looking through numerous drawings. To put this in perspective, the University of South Carolina’s use of BIM technology is expected to save them approximately \$900,000 over the next ten years at current energy costs. Using sustainable design and BIM technology buildings can be optimized for energy efficiency. Modifying the coordinates of the building to conduct daylight analyses, looking at site logistics, and creating energy models to see live and projected energy consumption are just a few of the ways that BIM was used to give the

University of South Carolina such significant savings (Gleeson, 2008). This is where the team sees the project having the greatest potential.

Since Alumni Gym is an existing structure that was built over 100 years ago, there was little technology available when construction took place, meaning designers were unable to truly visualize and analyze the building before it was constructed. Currently, there are BIM models that have been created to show both the existing structure and the proposed geometric changes for the soon to be Foisie Innovation Studio. Utilizing these models an energy analysis of the building can be conducted. Using BIM software the thermal performance of the building will be observed and translated into energy costs. Some of the potential software programs that are available to conduct this analysis will now be explained further.

In a survey conducted by Azhar and Brown, out of 91 design and construction firms, the most popular and powerful sustainability software programs are Autodesk *Green Building Studio*, Autodesk *Ecotect*, and *Integrated Environmental Solutions' Virtual Environment* (Azhar & Brown, 2009). Some of the key features that these programs provide are (Autodesk, 2010):

- **Thermal analysis:** Calculate the cooling and heating loads for models and observe the effects of equipment, occupancy, infiltration, and internal gains.
- **Energy Star & LEED Points:** Based on the performance and material usage Energy Star and LEED certification points are given.
- **Real time energy usage and costs:** Current energy costs can be input to provide an accurate estimate of yearly, monthly, daily, and hourly energy costs. The software uses a global weather database to simulate the conditions the building may face.

- **Photovoltaic collection:** Panel type, assumed installation costs, and electric utility costs are input to generate a payback period based on the photovoltaic potential of the building.
- **Daylight factors:** Calculate daylight factors and illuminance levels at any point in the model. Observe the sun's path and position relative to the model at any date, time, and location.

Another option for energy analysis, that has recently become available, is the use of *Autodesk Revit*. The latest versions of *Autodesk Revit* now come with energy analysis capabilities for both conceptual and detailed building design. In fact, *Revit* has absorbed the majority of the features that Ecotect can provide. Using *Revit's* MEP feature allows you to generate tables for heating and cooling loads based on a given HVAC system. This can be broken down by components such as doors, roofs, and windows to see where the "problem spots" are. *Revit* is also tied in with *Green Building Studio's* cloud based services. By setting some initial parameters such as location, building use, and thermal properties for materials, a report is generated giving you yearly energy costs and potential areas for savings.

With these BIM programs it is simple and efficient to test a variety of sustainable solutions and see its affects on cost and energy use. From an economic standpoint, for this project, *Autodesk Revit's* free student license with full analysis capabilities and subscription to *Green Building Studio* would be more resource friendly than purchasing a student license of *Integrated Environmental Solutions' Virtual Environment* for \$80 per license.

2.3 Thermal Analysis

In order to determine the building's thermal efficiency, a full thermal analysis must be conducted. A thermally efficient building would perform well in preventing heat flow through its exterior. Conducting a thermal analysis will allow our project team to identify the main areas of heat loss in the building. A high performance would mean that the building is effective at keeping heat inside while there are lower temperatures outside, or vice versa. One method of thermal analysis involves mapping surface temperatures of the heat flows through objects, specifically walls, windows, and doors. Taking pictures and calculating heat flow through surfaces is one easy way to discover the thermal performance of a surface. It is helpful in determining whether a building is efficient in regards to keeping heat inside during lower temperatures, and keeping heat outside during higher temperatures.

First, the process of heat transfer through a surface must be researched and understood by the project team. Looking at the equation, shown below, the value used for the heat transfer coefficient for a material will ultimately be the main factor in whether there is a high or low heat transfer through the surface. It will vary among building materials, such as brick, insulation, window, etc. Although the same equation is used for all materials, the heat transfer coefficient will change. These equations can be used with BIM modeling to analyze the thermal performance of the building. The main equation for heat transfer through a wall/window is:

$$q = hA(T_i - T_o)$$

q = heat flow through the wall

h = heat transfer coefficient (based on material)

A = cross sectional area of the wall

T_i = temperature inside the building

T_o = temperature outside the building

In addition to this process, the radiation from the sun must also be taken into account when analyzing the total heat flow. The solar radiation equation that will be utilized is:

$$G_{s,o} = S_c * f * \cos\theta \text{ where:}$$

$G_{s,o}$ = radiation from the sun
 S_c = average solar constant = 1353 W/m²
 f = correction factor for eccentricity in Earth's Orbit
 θ = angle from Earth's surface to the sun

Using *Revit* and *Green Building Studio* software, the highest problem areas will be identified with modifications from these two equations.

2.4 Thermal Imaging

For the thermal analysis of alumni gym, our project team will use thermal imaging to determine the building's efficiency. However, thermal imaging has many applications. Night vision goggles utilize thermal imaging features because the human body gives off heat that will contrast to any surroundings. Surveillance cameras with thermal capabilities are used by border patrol services, both land and sea, because they are able to spot targets up to a few miles away (FLIR, 2014). Firefighters can use thermal cameras during a fire because they will be able to find people through thick smoke, see holes in floors/walls due to burning, and even find where the fire originated to suppress the high volume of heat being released (Firefighting Applications, 2014). Some other major applications of thermal imaging include search and rescue of missing persons, medicinal diagnostics, and energy audits in buildings, similar to the research our group will be conducting.

Thermal imaging allows for collecting information on a building's thermal efficiency over a large-scale area. Taking pictures of larger areas allows for easy comparison for the amount of heat gained or lost in certain areas of the building. Thermal cameras use gray-scale colors to measure the intensity of heat transfer through a surface. Dark, or "cool" colors, such as black, blue, or purple, show that there is virtually no heat transfer through the surface. A structural member such as a beam, girder, or column, is one example where thermal images would display these darker colors. On the contrary, "hotter" colors such as yellow, orange, and red, indicates that there is significant heat transfer through the surface. Thermal images would most likely show these colors near windows or doors. As the main method of thermal testing and analysis, our project team will be using thermal imaging, coupled with BIM. Shown below is a thermal image of a typical home. The structural columns on the front porch show deep colors which imply that there is no heat transfer through this section of the house. However, near the windows and front door, there are bright orange-red colors which indicate high heat transfer through the surfaces. These are the surfaces in a building that will always display the highest heat transfer because the insulation is practically nonexistent at these areas.



Figure 3 Thermal Image of a Typical Home (Thermography Proves Energy Efficiency of Post Frame Buildings, 2013)

Our team will be utilizing two different camera types, the FLIR i7 and the FLIR E40 model. These images are taken in JPEG format so they are simple to work with when analyzing pictures for heat patterns. The i7 device shows temperature data on screen and is displayed in the picture as well. It works in temperatures ranging from -20°C to 250°C to a deviation of $\pm 2^{\circ}\text{C}$. The FLIR i7 can be operated using three different color palettes, allowing for very accurate readings for easy comparison (FLIR i3/i5/i7, 2014). The FLIR E40 is slightly more advanced than the i7. It works in ranges from -20°C to 650°C and can zoom to 2x normal distance for accurate readings of small areas. Temperature ranges can be set automatically, ranging from the highest and lowest temperatures shown on the screen, more manually to a specific temperature range. The thermal image is shown side-by-side with an actual picture so it is easier to understand what exactly the image is showing. It has ten different color palettes to choose from, which is many more than the i7 (New FLIR E-Series and E-Series bx, 2014). Using these images from the two cameras will allow for easy analysis when working with the BIM model.

2.5 Current Status of Building

Currently, the renovation is in the final stages of the design process. The architect for the project, Goody Clancy & Associates of Boston, is developing finalized construction documents and BIM models for the design of the project. There is a current deadline for these designs to be finished by the start of December. The construction manager for the project has also been selected and will be Shawmut Design and Construction based out of Boston, MA. They are currently involved in preconstruction services for the project. Shawmut has a prestigious reputation in the New England area, with offices based in Boston, MA; Providence, RI; New Haven, CT; and West Springfield, MA. The Boston office will be specifically handling the Alumni Gym renovation, with experience in projects very similar to the renovation of Alumni Gym. One project in particular that Shawmut completed back in 1997 was Harvard's Barker Center for the Humanities (Ruder, 1997).

The 16-month renovation project was completed in the summer of 1997, combining three historic buildings on Harvard's campus, the Harvard Union (circa 1901), Burr Hall (circa 1911), and the Warren House (circa early 19th century). The project totaled 80,000 square feet of interior renovation (Shawmut Design and Construction, 1997) and involved an extensive interior redesign by the architect, Goody Clancy & Associates of Boston. The design strived to reconfigure the buildings to allow maximum use by the new programs that would be utilizing the space while still retaining and reusing the original buildings' materials, details, and overall historic character. The exteriors of these buildings were repaired and restored, involving minimal new additions in an effort to preserve the historic envelopes of the buildings (Ruder, 1997).

With this previous experience, both Goody Clancy & Associates of Boston and Shawmut Design and Construction are currently working together to finalize the similar Alumni Gym renovation project. The design focuses on repurposing the old gym and athletic center into an innovation studio that aims to assist students as a collaborative work space for projects as well as a showcase for WPI student and alumni projects, innovations, and achievements. It will be the first physical presence on the WPI campus for the project based curriculum at the university, coined the “WPI Plan”. The project, in similar fashion to the renovation of the Barker Center, will focus on conserving the historical character of Alumni Gym. Originally constructed in 1911, Alumni Gym has sat at the center of the WPI campus for over a century (The Daily Herd, 2014). The new Foisie Innovation Studio renovation will still use the original exterior and structural components of the building, relying on the original materials of concrete, brick, and yellow pine. These components will be repaired and updated as necessary to assure the building is structurally safe and meets modern day building codes.

The new 34,255 square foot floor plan will feature a main 1400 square foot atrium that will be used to showcase the innovations and achievements of current and past WPI students. A schematic design for this atrium is shown in Figure 4. The overall aim for the renovation is to fill the need on campus for innovation space, tech suites, and areas for project collaboration (The Daily Herd, 2014). The specific layout includes a new robotics lab in the existing swimming pool area, an exploration and discovery center with advanced analytical equipment, two lecture halls specifically for first year greater problem seminars, tech suites with flexible configurations to meet student’s needs, the

showcase atrium with interactive displays, an open, interactive collaborative workshop for students on the top floor in the existing basketball court area, and the creation of a second main entrance on the north side of the building facing the campus center. There are also plans for more office spaces, conference rooms, tool cribs, project pods, work benches, and state of the art hardware and software (Worcester Polytechnic Institute, 2013). The university hopes to utilize this building as a physical showcase of the project-based curriculum as well as to encourage mixing between student disciplines and class years, housing both first year students taking Great Problem Seminars along with upper class students working in the collaborative areas on higher level projects, including fourth-year Major Qualifying Projects (The Daily Herd, 2014).



Figure 4: Schematic for the proposed design of the new Showcase Atrium from the south entrance (Worcester Polytechnic Institute, 2013).

The last main part of the renovation will be the removal of the current Alumni-Harrington Connector. This addition connects the two buildings through a series of locker rooms and athletic rooms. Due to the new WPI Sports and Recreation Center, this connector has also lost much of its use on the campus. Removal of this addition will create a new pathway from the quadrangle to the future West Promenade. Featured in Figure 6 the new promenade is planned to run behind the north side of Alumni Gym and south side of the Campus Center. The Foisie Innovation Studio at Alumni Gym will serve as a center piece of this promenade with the new north entrance helping to create a strong presence of the promenade (Worcester Polytechnic Institute, 2013).

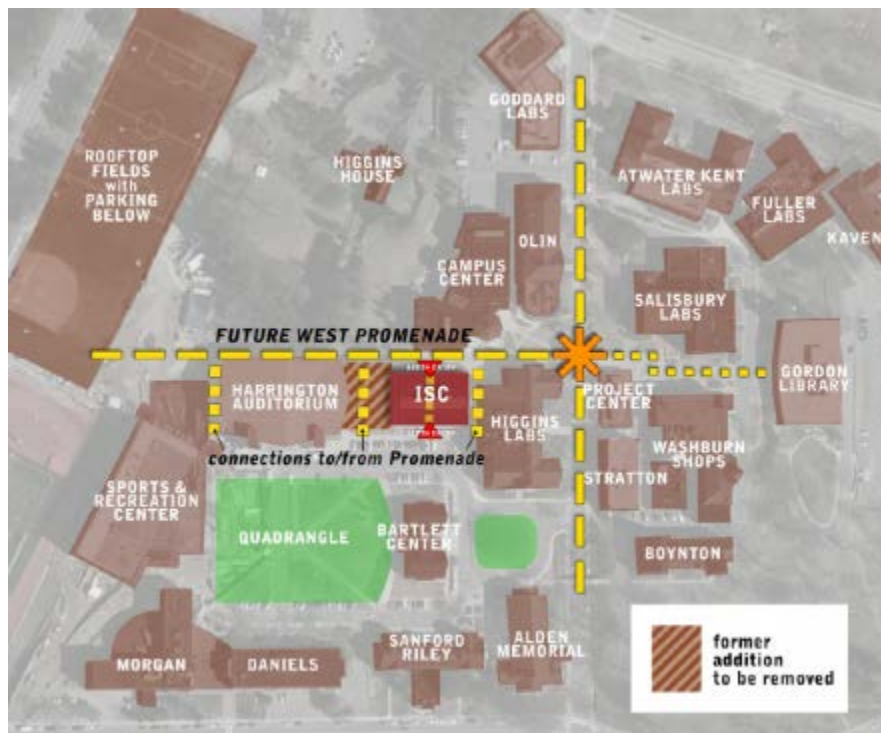

Figure 6: Suggested plan for Future West Promenade, connecting the parking garage and quadrangle with the fountain (located at orange star) and West Street (Worcester Polytechnic Institute, 2013).

Chapter Three: Methodology

The objective of this project is to assess the energy efficiency of the new Foisie Innovation Studio and provide suggestions to WPI on how to further improve the building's energy performance and reduce its environmental impact. To do this, the team plans to conduct three energy analyses on the soon to be Foisie Innovation Studio. The first analysis will observe the building in its current standing, the second will use the new geometry of the building and its proposed components, and the third model will be created testing different materials such as windows, insulation, and photovoltaic cells. The use of both thermal imaging and BIM software, such as *Autodesk Revit* and *Green Building Studio* will be the primary tools for the analyses. Additionally, a structural analysis will be performed on the roof components to ensure that the members can withstand the added loads of the proposed solar panels.

3.1 Analysis of Existing Building

The first analysis, as stated before, will investigate the current state and thermal efficiency of Alumni Gym. This will act as a benchmark and allow for later comparisons with other models and observe the improvements in terms of energy consumption, if any. To do this we will be utilizing a *Revit* model of Alumni Gym created by a previous MQP group and a graduate student. This model will need to be adjusted to reflect the current state of the building. The existing model reflects the envelope of the building, the current structural components, and some additional components that were suggested by the previous MQP. The gym will be visited to allow the team to determine which structural components exist and which were added into the model. This site visit will also allow the

team to gain an understanding of the existing layout and take notes on the interior partitions. The materials of the partitions, the thickness, and any irregularities will be the focus of the investigation. This information will be coupled with old building blueprints to completely update the model to reflect the current state of Alumni Gym.

Once the *Revit* model has been updated and confirmed to reflect the existing building, the team will then use *Revit* and *Green Building Studio* to analyze the thermal efficiency. The *Revit* model will be loaded into *Green Building Studio*; it will be tested and adjusted to close any air gaps and discontinuities. These will affect the results of the thermal analysis since the program will assume there is a permanent opening in the interior or exterior that would affect air and heat flows. To help ensure the accuracy of the software, thermal images will be taken of the building.

The team will have access to two similar models of thermal imaging cameras. Both cameras will be used during imaging of the building, the team splitting into groups of two. Images will be taken of the three accessible exterior sides as well as the exterior walls of every accessible interior room. Using heat transfer equations, as stated in the background chapter, the actual amount of heat loss for selected rooms within the building can be calculated. Three rooms of interest, the basketball court, the pool, and a regular office room will all be analyzed. Any rooms with irregular layouts or exterior walls will also be investigated. The team can then see whether or not the numbers generated in the software programs are consistent with the field data. These images can also be used to adjust the numbers generated from the model due to drafts and gaps that exist in the building. The *Green Building Studio* simulation will assume the exterior envelope is

continuous with no breaches; this is not necessarily true especially with a building as old as Alumni Gym. Lastly, the thermal images will allow the team to identify “problem areas” in the existing building that may need special attention as well as individual solutions. A step-by-step process for this first analysis is below.

1. Site visit of Alumni Gym for existing layout and materials
2. Review old interior blueprints of Alumni Gym
3. Update the existing model to reflect the existing layout
4. Complete simulation using the *Revit* model and *Green Building Studio*
5. Take thermal images of the three accessible exterior sides (outside looking in) as well as all interior rooms
6. Calculate heat loss for three key rooms in Alumni Gym. Check that this heat loss is similar to the model for accuracy.
7. Identify specific areas in the exterior of the gym that have large amounts of heat loss, based on the thermal images.

3.2 Analysis of Planned Renovation

Using *Revit* and *Green Building Studio*, the second model that will be analyzed will use the new interior layout and construction that has been put forth for the Foisie Innovation Studio. The new layout for the building will be developed using current schematic drawings from the architect. These two-dimensional drawings will be translated into the *Revit* model, creating a working model of the building under the current planned renovations. Once this data is compiled and analyzed using *Revit* and *Green Building Studio*, it can be compared to the benchmark performance and a

percentage change will be calculated. Areas relating to cost and heat loss will be analyzed, and the areas that perform poorly will be focused on when making recommendations for improvements.

The use of thermal imaging for this phase of the project would require substantial completion of construction for the results to noticeably differ from the benchmark analysis. Construction is scheduled to start in March of 2015, which suggests that it will be unlikely for the team to be able to analyze the renovated building using thermal imaging. Thus, the team will have to rely on the model and simulation results for comparison purposes. The process for this analysis is as follows:

1. Creation of new model based on construction drawings that reflects the planned renovations.
2. Thermal analysis simulation of *Revit* model in *Green Building Studio*.
3. Analysis of five major readouts from *Green Building Studio* with a percentage change comparison. The readouts are Energy Use Intensity, Life Cycle Energy Use/Cost, Renewable Energy Potential, Annual Carbon Emissions, and Energy Use.

3.3 Analysis of Possible Improvements

A third model will be created that incorporates any improvements that will be recommended based on the second model's performance. This model will incorporate modifications to the components of the building to try and maximize the efficiency of the building envelope. To do this we will, again, be using *Revit* and *Green Building Studio* software. Making changes to material properties such as insulation, window types, and adding solar panels, we will be able to evaluate possible benefits. Multiple simulations

will be performed in order to properly isolate the benefit that each change may bring. These proposed changes will be analyzed for their change in performance versus changes in cost, embodied energy, constructability, and impacts to the construction schedule. Examining these major areas, the team can perform a cost-benefit analysis and determine if making any of these changes are feasible.

Another major area of analysis for the environmental efficiency of the Foisie Innovation Studio is the embodied energy of the materials that will be used for construction. As discussed in the background, embodied energy is the amount of energy required for the manufacturing of materials. The team will analyze the materials currently being specified for the planned renovation for the amount of embodied energy they each require. Alternatives for those materials that have the highest levels of embodied energy will be investigated and evaluated based on the percentage change of embodied energy compared to the percentage change in cost.

1. Based on the original thermal images and the results of the two thermal simulations, better performing windows, insulation, and materials for construction will be placed into the model.
2. Each change to the *Revit* model will require a simulation in *Green Building Studio* and analysis of the five major readouts for percentage change.
3. Based on the materials currently specified for the building, new materials with lower embodied energy levels will be added to the model.
4. Each material swap in the *Revit* model will require another *Green Building Studio* simulation to isolate the changes in performance and cost.

3.4 Structural Analysis

In addition to examining the energy savings potential and performing, a structural analysis must also be performed. One of the proposed changes/additions that we will be mentioning is the implementation of photovoltaic cells (solar panels). Adding solar panels to the roof will increase loading that the roof members must withstand. Factors such as ice buildup, wind, uplift and increased dead load must be considered in this analysis. Using *ASCE 7 Minimum Design Loads for Buildings and Other Structures, International Building Code 2009*, and any modifications or additional provisions that the Commonwealth of Massachusetts has made to these codes will be considered to ensure the build meets code requirements. If the additional loading from the solar panels exceeds the limits specified in the codes, the members will require redesign to sustain the loading. This would be factored into the cost-benefits analysis of the solar panels. Below is a list of tasks to complete this analysis:

1. Review the analysis performed by last year's MQP
 - a. Verify dimensions
2. Select a brand/make of solar panel and gather information regarding dimensions, weight, and connection details and how many panels would be used.
3. Using *ASCE 7* define the minimum loading that the roof must withstand
4. Analyze the roof trusses and parapets to check if they meet the required strength
5. If members cannot support the added weight, roof members must be redesigned
 - a. A potential way to do this would be through the use of plate stiffeners added to the roof trusses.

6. How the solar panels are connected to the roof must also be investigated
7. Based on the structural analysis, results will then be factored into the cost-benefits analysis as mentioned earlier.

3.5 Life-cycle cost

After completing the three BIM models for the Foisie Innovation Studio, the team will complete a Life-cycle cost (LCC) to determine the total cost of the facility. A LCC will help the team analyze what energy savings products are the best for the building while taking into account the initial costs. In using the LCC, the team can complete a cost-benefit analysis on each of the proposed alternatives and determine which ones provide the greatest return on investment. Since the building is being renovated there will need to be three LCC's completed for this project; the first will be on the existing conditions of the buildings, the second on the proposed design from Shawmut Construction and the third will be the team's proposed design. While completing the calculations, the students need to take into account a number of different costs and rates. These include the initial cost, water and energy cost, operation, maintenance and repair costs, replacement costs, residual values, and other costs. After the completion of the LCC, the team will clearly define which renovation design provides the lowest overall cost of ownership consistent with the quality and function of the building. The steps the team will take to complete the LCC are shown below:

1. Determine the economic effects of alternative designs of the building and building systems.

2. Determine initial cost, water and energy cost, operation, maintenance and repair costs, replacement costs, residual values, and other costs associated with the renovation of the building.
3. Make sure all three LCC's are time equivalent by using a Present-Value Analysis
4. Determine an acceptable discount rate, this should be equal to the designer's acceptable rate of return.
5. Determine the length of study period, service period, and contract period.
6. Calculate the LCC using $LCC = I + Repl - Res + E + W + OM\&R + O$ where
 - LCC = Total LCC in present-value (PV) dollars of a given alternative
 - I = PV investment costs (if incurred at base date, they need not be discounted)
 - Repl = PV capital replacement costs
 - Res = PV residual value (resale value, salvage value) less disposal costs
 - E = PV of energy costs
 - W = PV of water costs
 - OM&R = PV of non-fuel operating, maintenance and repair costs
 - O = PV of other costs (e.g., contract costs for ESPCs or UESCs)
7. Compare the results of the three models to determine the most feasible options for the Foisie Innovation Studio

Based off these results, recommendations can then be made to WPI.

Works Cited

- ASCE. (2014). Retrieved October 11, 2014, from American Society of Civil Engineers :
http://www.asce.org/uploadedFiles/Ethics_-_New/Code%20of%20Ethics%20October%202010.pdf
- Autodesk. (2010). *Sustainable Building Design Software*. Retrieved September 30, 2014, from autodesk.com: <http://usa.autodesk.com/ecotect-analysis/>
- Autodesk. (2014, July 1). *Green Building Studio Validation*. Retrieved from Autodesk Green Building Studio: <http://knowledge.autodesk.com/support/green-building-studio/learn-explore/caas/CloudHelp/cloudhelp/ENU/BPA-GBSWebService/files/GUID-EF68E7D5-C0A5-4805-BFE5-7C74C57B712E-htm.html>
- Autodesk. (2014, July). *Green Building Studio Validation*. Retrieved from Autodesk Green Building Studio: <http://knowledge.autodesk.com/support/green-building-studio/learn-explore/caas/CloudHelp/cloudhelp/ENU/BPA-GBSWebService/files/GUID-EF68E7D5-C0A5-4805-BFE5-7C74C57B712E-htm.html>
- Autodesk. (2015). *Calculating the Conductive Heat Gain*. Retrieved from <http://help.autodesk.com/view/RVT/2014/ENU/?guid=GUID-6D3C2737-2810-42DE-894E-0A6B5DE24EE6>
- Autodesk. (2015). *Construction*. Retrieved from <http://knowledge.autodesk.com/support/green-building-studio/learn-explore/caas/CloudHelp/cloudhelp/2014/ENU/Revit/files/GUID-4E91A2A4-ED44-4D49-ACFC-D7636571AB3E-htm.html>
- Autodesk. (2015). *Heating and Cooling*. Retrieved from <http://help.autodesk.com/view/RVT/2014/ENU/?guid=GUID-45C16A16-EF62-4341-B190-F7458C5B83C6>
- Autodesk. (2015). *Heating and Cooling*. Retrieved from <http://help.autodesk.com/view/RVT/2014/ENU/?guid=GUID-D88E8A06-6E08-4CD6-89A0-368A2AD6C03C>
- Autodesk. (2015). *How Whole Building Energy Simulation Works*. Retrieved from http://help.autodesk.com/view/BUILDING_PERFORMANCE_ANALYSIS/ENU/?guid=GUID-30BE9353-50D0-4EA9-83C3-B40F74721A29.
- Azhar, S., & Brown, J. (2009). BIM for Sustainability Analyses. *International Journal of Construction Education Research*.
- Bergman, T., Dewitt, D., Incropera, F., & Lavine, A. (2011). *Fundamentals of Heat and Mass Transfer*. Hoboken: John Wiley & Sons, Inc.
- Bowman, M. (n.d.). Air Change Rates. Jacksonville, Florida, United States of America: Florida State College at Jacksonville.
- Choosing a Well-Insulated Window*. (2011). Retrieved from <https://www.energyguide.com/info/window2.asp>
- Epstein, E. (2012). *Implementing Successful Building Information Modeling*. Boston, MA: Artech House.

- Fennell, H. C., & Haehnel, J. (2005). Setting Airtightness Standards. *ASHRAE Journal*, 26-30.
- Firefighting Applications*. (2014). Retrieved from P&R Infrared: <https://www.pr-infrared.com/about-thermal-imaging/firefighting-applications>
- FLIR. (2014). *Thermal Imaging Cameras For Border Security and Coastal Surveillance*. Retrieved 2014, from FLIR: <http://www.flir.com/cs/emea/en/view/?id=42102>
- FLIR i3/i5/i7*. (2014). Retrieved from FLIR: <http://www.flir.com/cs/emea/en/view/?id=41963>
- Getting to know LEED: Building Operations and Maintenance (O+M)*. (2014). Retrieved from <http://www.usgbc.org/articles/getting-know-leed-building-operations-and-maintenance-om>
- Gevorkian, P. (2012). *Large Scale Solar Power Systems: Construction and economics*. Retrieved from <http://library.books24x7.com.ezproxy.wpi.edu/assetviewer.aspx?bookid=50214&chunkid=871987616>
- Gleeson, J. (2008). *Computer-Aided Green Design*. Retrieved September 22, 2014, from Architecture Week: http://www.architectureweek.com/0330/tools_1-2.html
- Hensley, J. E. (2011). *Improving Energy Efficiency in Historic Buildings*. Retrieved from <http://www.nps.gov/tps/how-to-preserve/briefs/3-improve-energy-efficiency.htm>
- Holliday, M. (2011). *Insulating Old Brick Buildings*. Retrieved from <http://www.greenbuildingadvisor.com/blogs/dept/musings/insulating-old-brick-buildings>
- Hong, T., Wang, C., Yan, D., & Zhu, D. (2012). *Comparison of Building Energy Modeling Programs: Building Loads*. Ernest Orlando Lawrence Berkeley National Laboratory.
- Judkoff, R., & Neymark, J. (2006). *Model Validation and Testing: The Methodological Foundation of ASHRAE Standard 140*. Quebec City.
- Kats, G., Alevantis, L., Berman, A., Mills, E., & Perlman, J. (2003). The Costs and Financial Benefits of Green Buildings. *A Report for California's Sustainable Building Task Force*.
- LEED. (2014). *Getting to know LEED: Building Operations and Maintenance (O+M)*. Retrieved from <http://www.usgbc.org/articles/getting-know-leed-building-operations-and-maintenance-om>
- LEED for Schools*. (2013). Retrieved from 1. <http://www.usgbc.org/leed/rating-systems/schools>
- Lott, M. (2011). *Guest Post: LEED – Not just a pretty plaque, and certainly not perfect*. Retrieved from <http://blogs.scientificamerican.com/plugged-in/2011/10/06/guest-post-leed-not-just-a-pretty-plaque-and-certainly-not-perfect/>
- National Oceanic and Atmospheric Administration. (n.d.). *Questions about Heating, Cooling Degree Days*. Retrieved from National Weather Service of Cleveland, Ohio: <http://www.erh.noaa.gov/cle/climate/info/degreedays.html>

- New FLIR E-Series and E-Series bx.* (2014). Retrieved from FLIR:
<http://www.flir.co.uk/instruments/display/?id=56911>
- Olbina, S., & Reeves, T. (2012). *Validation of Building Energy Modeling Tools: Ecotect, Green Building Studio, and IES.* Gainesville: University of Florida.
- Reed Construction Data, LLC. (2014). *RS Means Building Construction Cost Data.* Norwell.
- Rubino, J. (2014). *Alumni Gym MQP 2013-2014.*
- Ruder, D. B. (1997, September 11). *Barker Center Dedicated Tomorrow.* Retrieved from The Harvard University Gazette:
<http://news.harvard.edu/gazette/1997/09.11/BarkerCenterDed.html>
- Sefaira Fulcrum. (2014, August). *Sefaira Fulcrum & ASHRAE Standard 140-2011.* Retrieved from Sefaira:
<file:///C:/Users/Greg/Downloads/Sefaira%20Fulcrum%20Validation%20Testing%202014.pdf>
- Shawmut Design and Construction. (1997). *Harvard University Barker Center for the Humanities.* Retrieved from Shawmut Design and Construction:
http://www.shawmut.com/our_work/project-datasheets/acad-acadblld-hu-barker-data.pdf
- Smith, D., & Tardif, M. (2012). *Building Information Modeling a Strategic Implementation Guide for Architects, Engineers, Constructors, and Real Estate Asset Managers.* Chichester: John Wiley & Sons.
- Southface Energy Institute. (2011, March). *Blower Door and Duct Leakage Testing for Duct & Envelope Tightness Verification.* Atlanta, Georgia, United States of America: Southface Energy Institute.
- The Daily Herd. (2014, January 6). *Alumni Gym.* Retrieved from The Daily Herd:
<http://wp.wpi.edu/dailyherd/2014/01/06/alumni-gym/>
- Thermography Proves Energy Efficiency of Post Frame Buildings.* (2013, August 29). Retrieved from Hansen Buildings:
<http://www.hansenpolebuildings.com/blog/wp-content/uploads/2013/08/thermal-image-home.jpg>
- U.S. Department of Energy. (2006, December). *Table C3. Consumption and Gross Energy Intensity for Sum of Major Fuels for Non-Mall Buildings.* Retrieved from U.S. Energy Information Administration:
http://www.eia.gov/consumption/commercial/data/archive/cbecs/cbecs2003/detailed_tables_2003/2003set9/2003html/c3.html
- U.S. Department of Energy. (2011). *Air Leakage Guide.* U.S. Department of Energy.
- U.S. Department of Energy. (2011, January). *DOE Sponsored Tools - Building Energy Simulation Tests.* Retrieved from
http://apps1.eere.energy.gov/buildings/tools_directory/doe_sponsored_bestest.cfm
- Worcester Polytechnic Institute. (2012). *WPI Sustainability Plan.*

Worcester Polytechnic Institute. (2013). *A Dynamic Expression of the WPI Plan*.
Retrieved from https://my.wpi.edu/bbcswebdav/pid-367679-dt-content-rid-1803312_1/courses/MQP-LDA1501-A14-D14/WPI_11x17%20layout_011613.pdf

Appendix B: Personal Communication

Communication with the Architect

1. In the discussion on insulation for the exterior walls of the existing structure, you explained that this was going to be avoided due to damage to the masonry that the moisture could cause. We were curious if using a vapor barrier with the insulation was a possible option and if not, why this isn't possible.

Providing insulation in concert with an air and vapor barrier affects the hydrothermal performance of mass masonry walls. Essentially the wall has always gotten wet during inclement weather but has been allowed to dry out. By adding insulation and AVB to the interior surface we would essentially eliminate this drying process and as a result the walls would remain wet and cold during the winter months and experience extended periods of freeze thaw. We have observed in the construction of historic buildings of this period, masons often used the highest quality bricks on the exterior wythes saving those less durable units for the interior. If materials are not durable or are vulnerable to moisture, changing the thermal performance of the wall may be harmful to the long term performance of the wall.

Understanding the impact associated with insulating and controlling vapor transfer in historic mass masonry walls can be achieved by hydrothermal analysis, extensive material testing to characterize the materials durability and air infiltration testing to understand the permeability of the wall. Our sustainable approach to the rehabilitation of the Alumni Gym was to minimize demolition of existing materials and to adaptively re-use the facility while minimizing environment impacts. The team had to consider the upfront costs of engineering, analysis and material testing, the demolition of the existing interior walls and the required new construction... against the cost savings associated with the improved energy performance of the exterior envelope and the long term payback.

2. Is there a minimum R-Value in the Massachusetts Building Code for the renovations of historic buildings that the project must meet?

Below are the relevant code sections which govern existing buildings in Massachusetts. As we are not altering the existing wall cavity during construction and not increasing the building energy use, calculated using the ASHREA 90.1-2007 building baseline against proposed design energy models, no insulation at the walls is required.

- 2012 IECC will apply since this is a renovation project to an existing commercial building.

- C101.4.1 & C101.4.3- In general existing buildings are permitted to have previously approved materials remain in use unless they are altered, removed, or replaced as part of the renovation project. Alterations and renovations are not permitted to create an unsafe or hazardous condition or overload existing building systems. The following need not comply provided the energy use of the building is not increased:
 - o Storm windows installed over existing fenestration
 - o Glass only replacements in an existing sash and frame
 - o Existing ceiling, wall or floor cavities exposed during construction provided that these cavities are filled with insulation.
 - o Construction where the existing roof, wall or floor cavity is not exposed.
 - o Reroofing for roofs where neither the sheathing nor the insulation is exposed. Roofs without insulation in the cavity and where the sheathing or insulation is exposed during reroofing shall be insulated either above or below the sheathing.
 - o Replacement of existing doors that separate conditioned space from the exterior shall not require the installation of a vestibule or revolving door, provided however, that an existing vestibule that separates a conditioned space from the exterior is not removed.
 - o Alteration that replace less than 50 percent of the luminaries in a space provided that such alterations do not increase the installed interior lighting power.
 - o Alteration that replace only the bulb and ballast within the existing luminaries in a space provided that the alteration does not increase the installed interior lighting power.
- C101.4.6- Any non-conditioned space that is altered to become conditioned space is required to be brought in to full compliance with the code.
- C401.2.1- Alterations to existing buildings are subject to one of the following:
 - o Section C402 (Building Envelope), C403 (Mechanical Systems), C404 (Service Water Heating), and C405 (Electrical Power and Lighting Systems); or
 - o ANSI/ASHRAE/IESNA 90.1

Communication with Professor Elovitz

Alumni Gym 2 – Robert A. Foisie Innovation Studio

Attendees: Professor Elovitz, Greg Kornichuk, Taylor Landry, John McGonagle, Zach

Blanchard

KH 111a

February 3, 2015

Agenda:

1. Update of our project
2. What we are trying to accomplish with hand calculations and *Green Building Studio* (more so the equations)
3. How do we find the amount of energy needed to keep the internal temperature at a specific temp. (65°F for example)
 - a. How do we factor in time of day, daylight effects?
 - i. 3 timeframes (average temp for each time)
4. Heat transfer equations and how they pertain to the project
5. Any specific energy equations
6. General understanding of the project and the processes needed

Minutes:

- Finding some energy benchmarks to compare our model to would be helpful. Department of energy provides Energy Use Index values.
 - Our building may fall under Light R&D
- Would be best to present monthly heating loads on the same scale as other graphs
- Need to look into what misc. equipment is used to get equipment energy use value. Find GBS assumptions
- Look into why there are cooling loads in the winter months
- Random elec. Highs and lows- investigate
- Prof. Elovitz made a graph of Heating degree days vs. therms, values seem off

- When looking at PV potential take the 10% value. Typ. Solar panels around here run at 13%
 - Recommended getting utility info from facilities-Mary Lou may have contact information for us.
 - Worcester is in climate zone 5A (for benchmarking numbers)
 - Useful text
 - HVA Systems Design Handbook- Roger Hanes
 - PITA
 - Ashrae handbook
 - It is possible to evaluate efficiency performance through heat transfer equations in terms of resistance, but generating actual conditions (in terms of cost and actual energy use) is much more complex.
 - ComCheck online can be used to get some values
-

Alumni Gym 2 – Robert A. Foisie Innovation Studio

Attendees: Professor Elovitz, Greg Kornichuk, Zach Blanchard

February 17, 2015

Agenda:

1. Results of hand calculations for conduction values
 - a. How they compare with values for Green Building Studio
 - b. If the results are reasonable
2. Possibility of calculating infiltration rate through means other than the BIN method as described in last meeting.

Minutes:

1. How we arrived at our BTU/h values seems off – our value should be much higher than the expected because of internal heat gains that conduction does not account for

2. Calculating the values for each month by average high temperatures and average low temperatures does not make sense because the temperature is not constant at all times throughout the month – try using heating degree days because it accounts for the changing temperature throughout the month
3. Internal heating gains through people is negligible (250 BTU/h/person is very small compared to our values in the millions of BTU/h)
4. Calculating the infiltration rate through our means can be a good estimate – make sure we explain why we are choosing the air changes per hour that we use
 - a. Find studies that give typical ACH values for buildings similar to Alumni.
 - b. For residential buildings, infiltration rate is generally similar to the conduction values – something to consider

Appendix C: Green Building Studio Calculation Information

Green Building Studio uses a dynamic energy simulation with multiple factors that take into account the building's form, materials, use, and climate. The first level of analysis is the building's geometry. The geometry or form of the building includes the area, volume, layout, and orientation. These are primary factors in the calculation of a building's energy consumption through an Energy Analysis Model (EAM). The next step in the analysis is the buildings spaces and thermal comforts. These spaces exchange heat with the outside environment and with each other. The third level of the simulation is the surfaces and heat transfer. The heat transfer occurs across surfaces of the model in the geometry that represent the walls, roof, floors, and windows of the building. The material properties are then taken into account by the model. The thermal properties take into account the material's density, specific heat capacity, and the conductivity. The material properties of the surfaces are combined to determine the thermal properties of the building. The EAM uses these thermal properties to adjust the heating and cooling energy loads.

Once the buildings surfaces have been fully accounted for, the EAM then analyzes the systems of the building. These include the HVAC, lighting, equipment, water heating, and renewable energy. All these systems consume or produce energy, affecting the overall energy consumption. The last major portion of the energy analysis is the dynamic loadings that result from the occupants and the environmental conditions outside the building. These include heat and humidity from people, target temperatures of the spaces, the exterior climate, average wind speeds and direction, solar radiation, and

infiltration assumptions. Once all of these properties are determined and the loads calculated, the heat transfer will be simulated over time, generally on a yearly basis. After all of this data is collected by the EAM, the program can extract the energy use and create cost predictions (Autodesk, 2015).

With all of the data for the building assembled, the engine of the EAM can calculate the heating and cooling loads. The cooling load calculation assumes steady periodic conditions. This means that it is assumed that the weather, occupancy, and heat gain that are simulated at a certain time reoccur at the same time every 24 hours. Two main time-delay effects must be addressed for cooling loads. These are the delay of conductive heat gain through opaque exterior surfaces and the delay of radiative heat gain being converted to cooling loads. The difference in exterior and interior temperature differences and solar energy absorbed by the exterior surfaces cause a transfer of energy by conduction through the walls. The calculation takes into account the delay due to the mass and thermal capacities of the walls and roof, resulting in a time delay from the heat input becoming a heat gain on the interior. Heat transfers within the interior generally occur through a combination of radiation and convection. The energies transferred through convection immediately result in increased cooling load. The radiated energies have a delay (Autodesk, 2015).

The energy must first be absorbed by the finishes and masses of the interior, with different thermal properties resulting in different time delays. These energies only result in increased cooling loads when it is transferred from the surfaces to the air of the room

through convection. This method for calculating required cooling loads for a building is known as the Radiant Time Series Method (Autodesk, 2015).

An entire overview can be seen in flow chart shown in Figure 28.

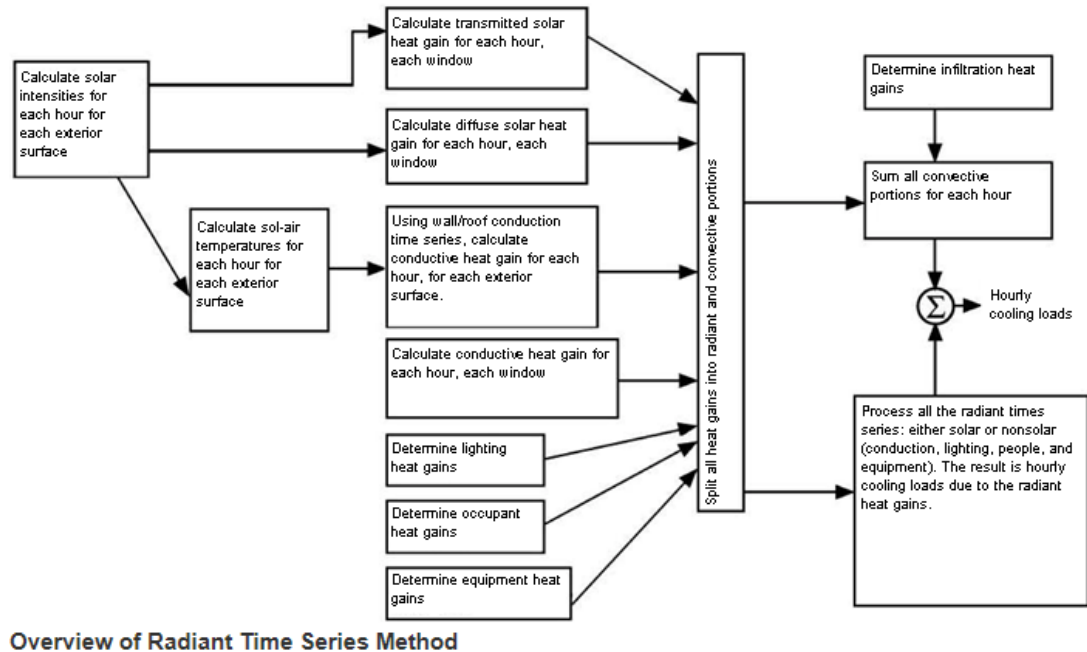

Figure 28: Overview of Radiant Time Series Method

Once the cooling load is calculated, the heating load is then calculated. The process is very similar to calculating the cooling loads. The heating load simulation has several exceptions though. It excludes the credit from solar and internal heat gains. It also ignores the thermal storage effect of the building structure, meaning heat losses are considered to be instantaneous. Heat transfers are also essentially conductive and latent heat is treated as a function of replacing space humidity lost to the exterior environment. This approach is simplified but is used as it represents the worst case scenario for a heating situation.

The main equation to determine the transfer of heat within the surfaces of the building is the heat capacity equation. Each material type contains the thermal properties of thickness, conductivity, density, specific heat, and resistance. The heat capacity equation is shown in Figure 29.

Equation N2-1	$HC = \sum_{i=1}^n (\rho_i \times c_i \times t_i)$
where:	
n	is the total number of layers in the assembly
ρ_i	is the density of the i^{th} layer
C_i	is the specific heat of the i^{th} layer
t_i	is the thickness of the i^{th} layer
all in constant units.	

Figure 29: Heat Capacity Equation

This equation calculates the heat capacity of an assembly within the building that allows for calculation of the heating and cooling loads (Autodesk, Construction, 2015).

There are also specific equations the engine uses for calculating the conductive heat gain and losses of the walls and roof. These equations can be seen in Figure 30 (Autodesk, Calculating the Conductive Heat Gain, 2015).

$$q_{i,q-n} = UA(t_{e,q-n} - t_{rc}) \quad (31)$$

where

$q_{i,q-n}$ = conductive heating input for the surface n hours ago, Btu/h

U = overall heat transfer coefficient for the surface, Btu/h·ft²·°F

A = surface area, ft²

$t_{e,q-n}$ = sol-air temperature n hours ago, °F

t_{rc} = presumed constant room temperature, °F

Figure 30: Heat Conduction Equation

Appendix D: Storage Test Runs

Prior to completing simulations using the Alumni Gym model, a small storage shed located on the WPI campus was modeled to gain a deeper understanding for the major factors that change the life cycle energy costs. This appendix outlines every test run of the simulation, the results of each factor being compared to a control simulation of the existing model as it currently exists. Each simulation's results are discussed and any major conclusions drawn are located below. The *Green Building Studio* readouts for each test run can be found with the electronic files for the project, their locations detailed in Appendix M.

Test 1: Control Test

For the control the, the building was modeled after existing conditions. Major aspects of the buildings were:

1. Exterior walls were 8" double layer brick with no insulation.
2. Windows were single pane glass.
3. Exterior doors were solid core wood.
4. One end of the building had the existing garage door.
5. The roof was asphalt shingles with a single layer of plywood sheathing.
6. The foundation was 12" concrete walls.

The control model was uploaded to Green Building Studio and the energy analysis model was run through the simulation. The results, shown below in Figure 31 yielded a total 30 year fuel consumption of 52,461 Therms (one Therm is equal to 100,000 British Thermal Units or BTUs) and a life cycle energy cost of \$49,992. This is the baseline amount that was used to compare to all other test runs.

Life Cycle Electricity Use:	343,861 kWh
Life Cycle Fuel Use:	52,461 Therms
Life Cycle Energy Cost	\$49,992
*30-year life and 8.1% discount rate for costs	

Figure 31: *Green Building Studio* output for control run of the Storage Shed

Test 2: Improved Exterior Insulation

For the next test, the effect of improving the thermal properties of the exterior envelope of the storage shed was tested. Two inch rigid insulation was added to the exterior wall assembly with a layer of ½" drywall covering the insulation. The same was done to the roof. The simulation for this altered model was completed and the results yielded total 30 year fuel consumption of 39,104 Therms and a life cycle energy cost of \$38,929. This was a reduction in fuel consumption of 13,377 Therms and a reduction of life cycle energy cost of \$11,063. This is a percentage reduction of 25.49% and 22.13% respectively.

Test 3: Effect of the Site Items

The storage shed has multiple large trees surrounding it. These trees help block natural light, something that affects the energy efficiency of a building. The control model was modified by placing large trees around the building. The simulation was conducted with limited effects on the energy consumption of the building. The trees did not affect the life cycle energy costs or fuel consumption, giving evidence that the simulation does not account for objects placed in the site.

Test 4: Proper Orientation of Building to True North

When the control model was rotated to represent the proper orientation of the existing building, there was a slight change to the amount of fuel consumed and the life cycle energy cost. Both were reduced by 204 Therms and \$60 respectively. When the building was rotated a 180° from its existing orientation, the fuel and life cycle energy cost was further reduced, a total of 374 Therms and \$198 respectively. Based on these tests, the orientation of the building is important to keep accurate but does not have a huge effect on the energy costs, especially if the number of windows and openings are similar on each side of the building.

Test 5: Orientation of Building Rotated 90° Clockwise From Proper Orientation

The model rotated 90° clockwise from the proper orientation from true north. This resulted in a slight decrease of \$33 in life cycle energy costs. This is consistent with the previous test that the orientation has some affect but not a large one in the program. The slight decrease is likely due to more windows facing the southern direction when the building is rotated 90°, the south side being the sunny side of buildings in the northern hemisphere.

Test 6: Orientation of Building Rotated 180° Clockwise From Proper Orientation

The model further rotated 180° clockwise from the proper orientation in reference to true north further decreased the life cycle costs a total of \$138 and Therms by 107. This resulted in the garage door facing in a southerly direction and the majority

of windows on the side of the building with the largest number of windows facing the easterly direction.

Test 7: Three Rooms Divided by 7" Wide Partition with 2" Rigid Insulation

This simulation took the control model, which was originally a single large room, and split it into three separate rooms. The partition that divided this space was made from 3 5/8" metal studs, one 2" layer of rigid insulation, and two layers of 3/4" gypsum drywall. The main partition ran length wise down the building, parallel to Park Ave, as shown below in Figure 32.

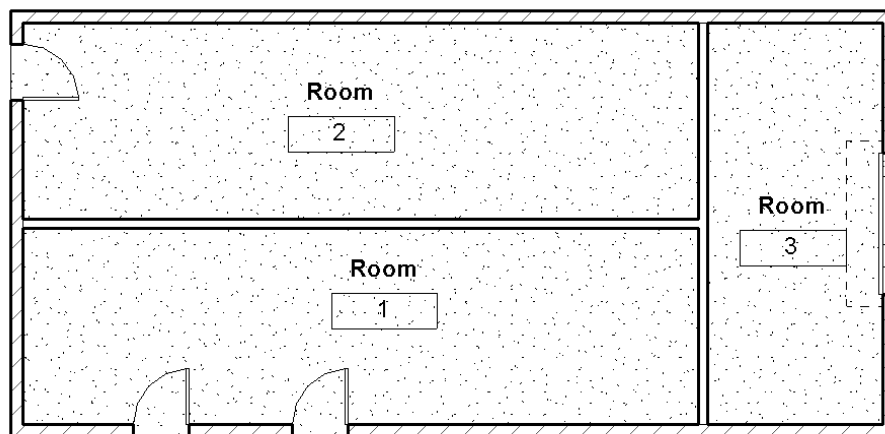

Figure 32: Test 7 design in the storage shed

The division of this interior space resulted in a decently large increase in the amount of projected Therms and the lifecycle energy cost, an increase of 1346 and \$1237, respectively. Originally, it was predicted that the division of the building would result in cheaper heating costs, the smaller spaces possibly being less taxing to heat. However, there was the opposite effect. This might be due to reduction of sunlight and air flow between buildings whereas it was one large space previously.

Test 8: Six Equal Rooms Divided by 7" Partition with 2" Rigid Insulation

To test how splitting the interior up affected the simulation, the model was further divided into six equal sized rooms by the same partition type as in the previous test. The result further proved that the more divided up the interior of the building is, the higher the heating and cooling load for the building in the simulation. For this layout, the increase from control for life cycle energy costs was \$4604 and an increase in Therms of 3491.

Test 9: Six Equal Rooms Divided by 5.5" Partition with No Insulation

The next test aimed at measuring the affect that just having the interior partitions had versus the thickness and insulation in the interior partitions. The result of the simulation was a further increase in the amount of life cycle energy cost and fuel use. This resulted in a total of \$56,855 and 57,550 Therms, an increase from Test 8 of \$2259 and 1598 Therms. This showed that splitting the space up within the program has a large effect on the thermal efficiency of the building as a whole. When the interior walls are insulated, it helps to reduce the overall cost, according to the program.

Test 10: Simulation Building Type Changed from Warehouse to Workshop

Within Green Building Studio, there is an option to select the building type. This allows the program to more accurately predict building consumption in respect to electricity and ventilation requirements. It also gives the program default settings if aspects are needed to be assumed. For each building type, the program has data for consumption of over 600 buildings that it uses to draw its data from. In switching the building type from a warehouse to a workshop, there was actually a decrease in the

amount of Therms consumed down to 51,736 Therms compared to 52,461 Therms in the control. However, the Lifecycle Energy increased due to an increase in the amount of electricity consumed. This is expected as one would think a workshop would require more electricity than a warehouse.

Test 11: Existing Garage Door Replaced with Curtain Wall

To test the effect of sunlight and doorways in the program, the existing garage door was replaced with a curtain wall. Overall, the amount of energy consumed and life cycle costs decreased slightly as one might expect, a solid glass wall being less drafty than a garage door and allowing more natural sunlight into the building. The overall affect was a decrease of 739 Therms and \$379, respectively.

Appendix E: Phase One Green Building Studio Output

Below is the readout created from the *Green Building Studio* simulation of the Phase One Existing Model. A preliminary check of the output was completed to first analyze whether the results made sense.

Energy Analysis Result

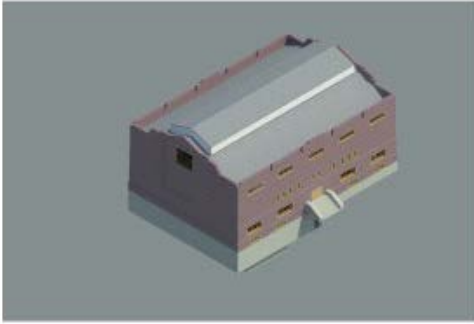

Building Performance Factors

Location:	Boston, MA
Weather Station:	53158
Outdoor Temperature:	Max: 82°F/Min: -10°F
Floor Area:	35,925 sf
Exterior Wall Area:	16,443 sf
Average Lighting Power:	1.01 W / ft ²
People:	33 people
Exterior Window Ratio:	0.11
Electrical Cost:	\$0.14 / kWh
Fuel Cost:	\$1.16 / Therm

Energy Use Intensity

Electricity EUI:	7 kWh / sf / yr
Fuel EUI:	45 kBtu / sf / yr
Total EUI:	70 kBtu / sf / yr

Life Cycle Energy Use/Cost

Life Cycle Electricity Use:	7,585,758 kWh
Life Cycle Fuel Use:	473,324 Therms
Life Cycle Energy Cost:	\$743,536

*30-year life and 6.1% discount rate for costs

Renewable Energy Potential

Roof Mounted PV System (Low efficiency):	100,187 kWh / yr
Roof Mounted PV System (Medium efficiency):	200,375 kWh / yr
Roof Mounted PV System (High efficiency):	300,562 kWh / yr
Single 15' Wind Turbine Potential:	2,969 kWh / yr

*PV efficiencies are assumed to be 5%, 10% and 15% for low, medium and high efficiency systems

Annual Carbon Emissions

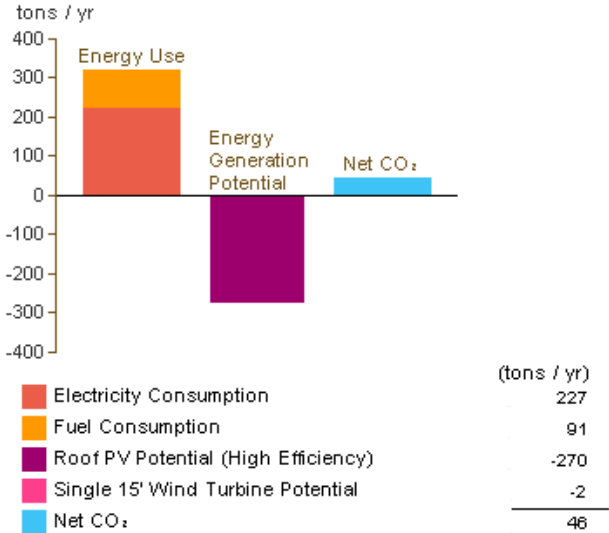

Annual Energy Use/Cost

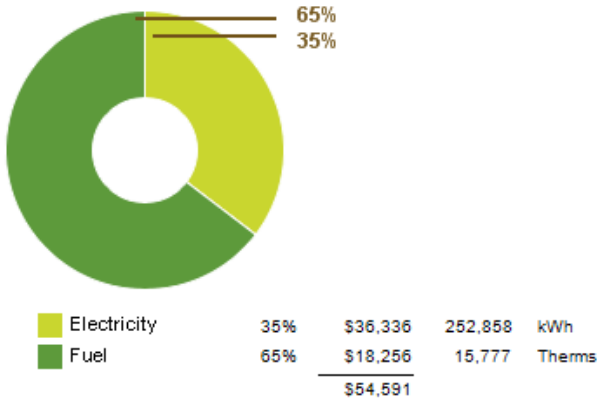

Energy Use: Fuel

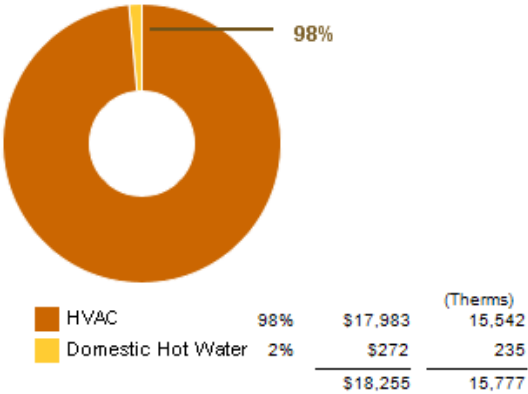

Energy Use: Electricity

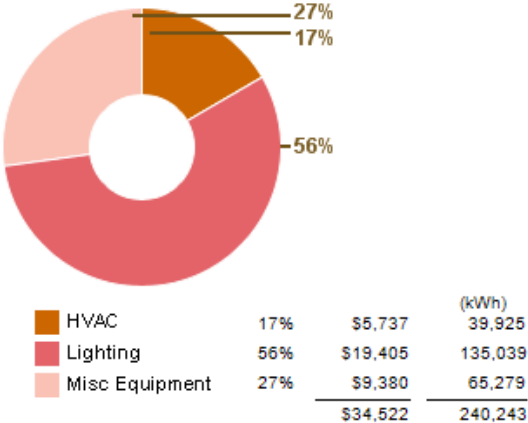

Monthly Heating Load

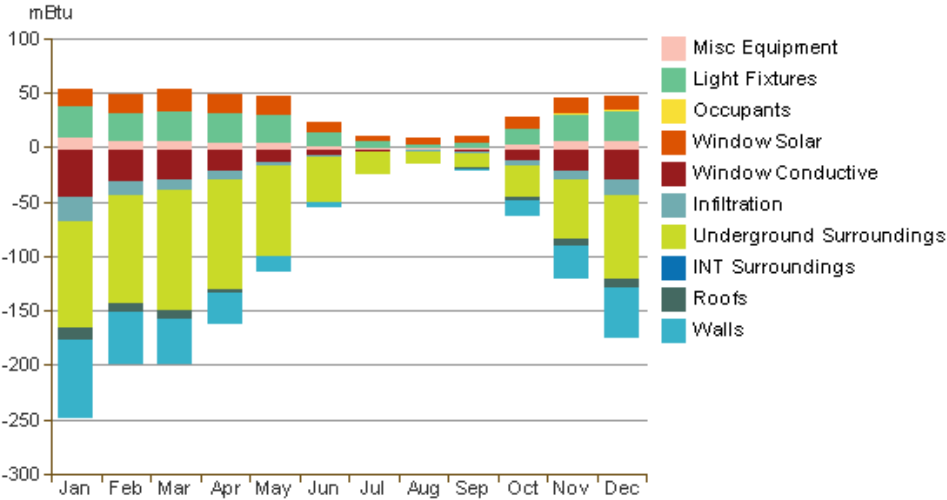

Monthly Cooling Load

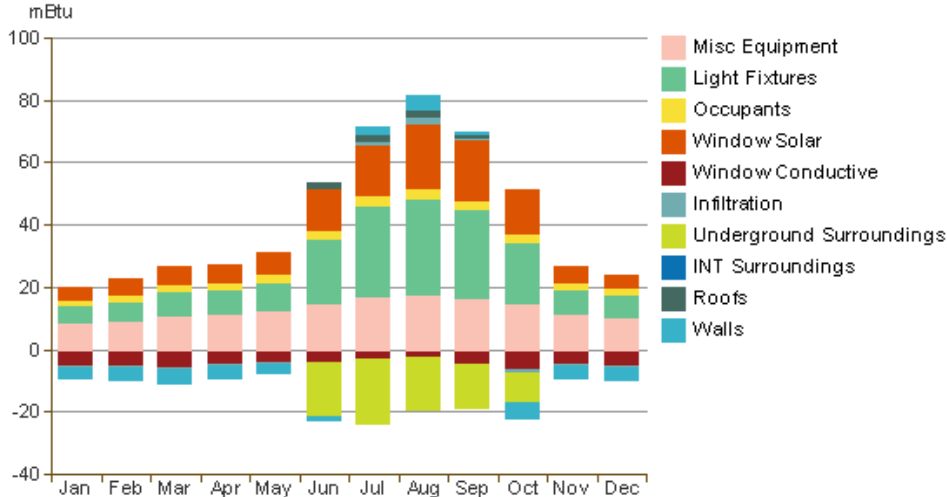

Monthly Fuel Consumption

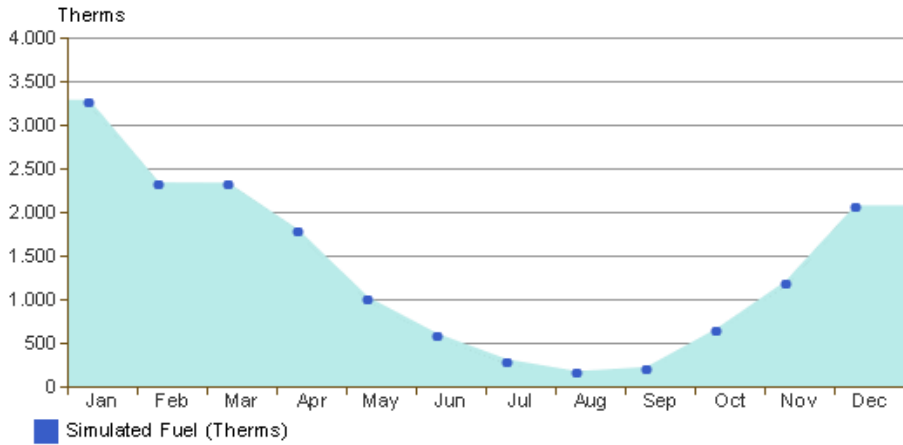

Monthly Electricity Consumption

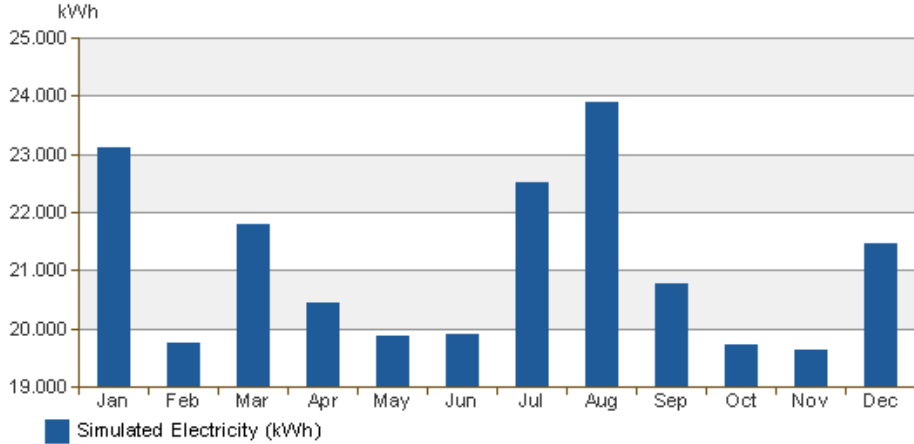

Monthly Peak Demand

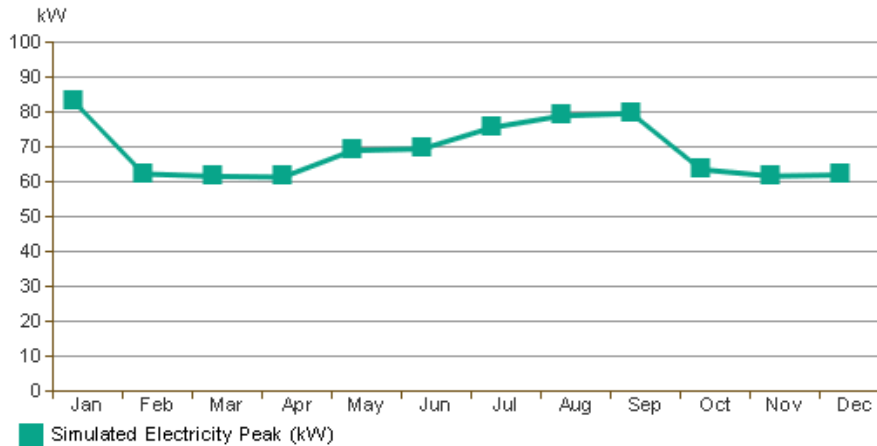

Of all the tables, the only data that seemed skewed was the table of electricity consumption. One would expect this to follow a pattern of spiking during the summer from air conditioner use, decrease in the fall as the weather cools, spike again in the winter due to the shorter length of time that the sun is up, and decrease again in the spring as the days get longer. However, several months did not follow this pattern, specifically February having a very low consumption and March having a high consumption. After checking within the model, no solution was ever discovered for this discrepancy. Further checks through energy intensity values and hand calculations were completed to also check the validity of this readout.

Appendix G: Green Building Studio Error

Once the proposed changes were all reflected in the new *Revit* model, the simulation was run once again in *Green Building Studio*. During the simulation in *Green Building Studio*, an error occurred stating that one of the layers in the wall assemblies was too thin to allow the simulation to run. The actual error message is shown below in Figure 35.

```
Issue: An error has occurred related to the DOE-2 simulation. It is below and may be of assistance in determining the issue with your building model. If it is unclear what the issue is, please submit the issue at the link below and include the gbXML file used for this run. <br/> * 606 * ..<br/>
> *ERROR*****<br/> *ERROR***** Cannot simulate LAYERS aim0266 as
given. The wall is too thin or<br/> *1259 * ..<br/> *ERROR***** == *****<br/>
> *ERROR***** aim0266 has no data due to previous error<br/>
```

Figure 35: Error message encountered when trying to run the Green Building Studio that caused the simulation to fail.

Upon receiving this error message, the first step in troubleshooting was to review every layer and material in the model and check that valid thicknesses and properties were defined. After several more failed simulations, the next step was to start eliminating elements of the model that had changed from the first phase. Assembly by assembly, new interior partitions were deleted, each time the simulation being rerun to check if the problem had been solved. Eventually, the model was left with only the exterior shell and the interior floor slabs. At this point, the model still was failing. The new glass north entrance was then deleted out and replaced with a normal masonry wall. This also yielded a failed simulation run.

The issue was also researched in *Autodesk Revit* help. The error is a known limitation within the simulation engine that *Green Building Studio* runs on, DOE-2.2. The solution presented by *Autodesk* can be seen in Figure 36 below.

The error you are seeing is due to a known limitation in the DOE-2 simulation engine which GBS is built upon. Unfortunately there really isn't a way to determine when users will get that error since the engine looks at u-value, thickness, exposure, temp. settings, among other things to make this determination.

Solution:

The only workarounds at this time, are to make the walls thick enough to run (in some cases we've seen them have to be 18"), use the spaces mode, or not use thermal settings.

Figure 36: Solution to error message provided by Autodesk.

The model had only exterior walls present, all over 18" in thickness. The simulation would run if the thermal properties of the materials in the model were not used. However, this yields a life-cycle cost that is very generalized based on buildings similar to the model and not the actual specific thermal properties.

Cost-Benefit Analysis:

Recommendation	Total Heat Loss (Therms)	Increase/Decrease	Percent Change in Heat Loss	Unit Cost to Install	Total Cost to Install
Improvement of Windows/Skylights					
Existing Single Pane	=Analysis!H200+Analysis!J200+Analysis!L200+Analysis!			50	=E14*Analysis!C200
Proposed Double Pane Replacement	=Analysis!H201+Analysis!J201+Analysis!L201+Analysis!			70	=E15*Analysis!C201
Change from Single to Double Pane	=B14-B15	Decrease	=B16/B14		=F14-F15
Proposed Double Pane	=Analysis!H204+Analysis!J204+Analysis!L204+Analysis!			70	=E18*Analysis!C204
Recommendation to Triple Pane	=Analysis!H205+Analysis!J205+Analysis!L205+Analysis!			80	=E19*Analysis!C205
Change from Double to Triple Pane	=B18-B19	Decrease	=B20/B18		=F18-F19
Improvement of Exterior Brick					
Proposed Brick Exterior	=Analysis!H212+Analysis!J212+Analysis!L212+Analysis!			0	0
Brick Exterior with EIFS Finish	=Analysis!H214+Analysis!J214+Analysis!L214+Analysis!			12.09	=E26*Analysis!C214
Change from Brick to Brick with EIFS Fin	=B25-B26	Decrease	=B27/B25		=F25-F26
Improvement of Roof Insulation					
Proposed Roof	=Analysis!H257+Analysis!J257+Analysis!L257+Analysis!			1.65	=E32*Analysis!C257
Recommendation to Increasing to 8" Rigi	=Analysis!H259+Analysis!J259+Analysis!L259+Analysis!			=1.65+0.67	=E33*Analysis!C259
Change from Proposed to 2" Increased	=B32-B33	Decrease	=B34/B32		=F32-F33
Recommendation to Increased 12" Rigi	=Analysis!H261+Analysis!J261+Analysis!L261+Analysis!			=1.65*2	=E35*Analysis!C261
Change from Proposed to 6" Increased	=B32-B35	Decrease	=B36/B32		=F32-F35
Installation of Solar Panels					
	Square Footage Available	Square Footage per	Total Number Panels	Unit Cost to Install	Total Cost to Install
Installing Solar Panels on Entire Roof	8000	=4*8	=B42/C42	930	=E42*D42
Installing Solar Panels South Side roof	2360	=4*8	73	930	=E43*D43

Summary of conduction heat loss and corresponding graphs:

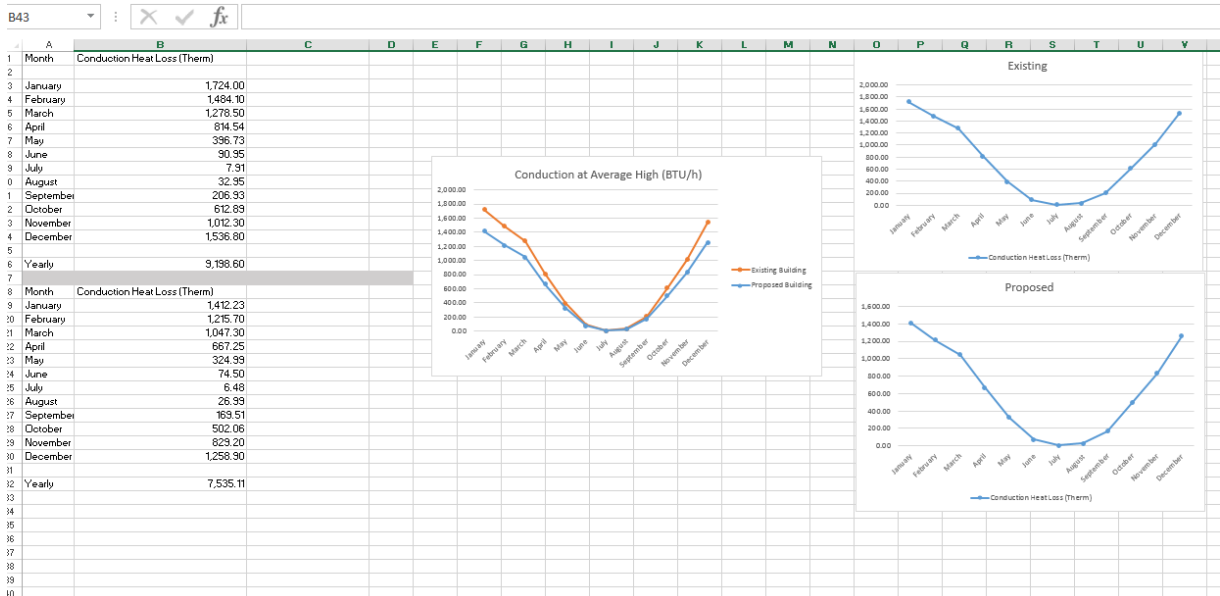

Comparison of Conduction Heat Loss Hand Calculations and GBS Total Heat Loss:

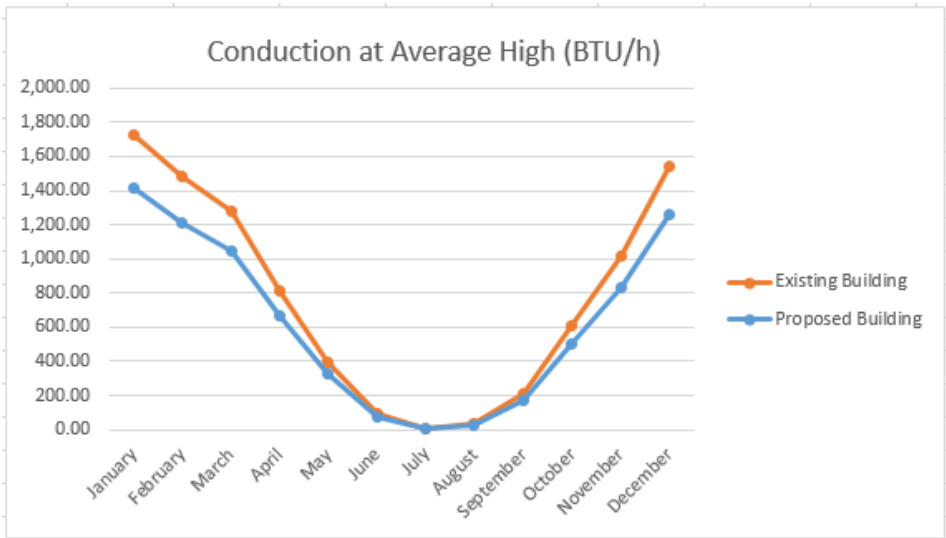

Figure 37: Graph of hand calculated heat loss for existing and proposed building

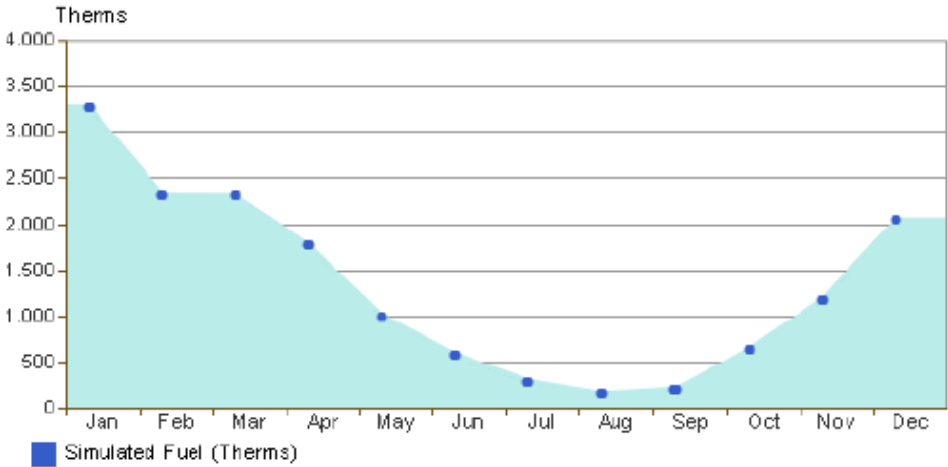

Figure 38: Graph generated by Green Building Studio for total heat loss of existing building

Appendix I: Truss Analysis of Existing Conditions

elem	Force (kips)	Stress (ksi)	strain
1	144.2	7.3	0.000251
2	153.3	7.7	0.000265
3	168.0	8.4	0.000290
4	-281.6	-14.1	-0.000485
5	-296.3	-14.8	-0.000511
6	-305.4	-15.0	-0.000518
7	281.9	14.5	0.000500
8	281.9	14.1	0.000487
9	269.2	13.5	0.000464
10	252.3	12.6	0.000436
11	252.3	12.6	0.000436
12	269.2	13.5	0.000465
13	281.9	14.1	0.000487
14	281.9	14.2	0.000488
15	0.0	0.1	0.000002
16	-11.6	-0.7	-0.000026
17	9.2	0.6	0.000022
18	-17.9	-1.2	-0.000040
19	17.1	1.1	0.000040
20	17.1	1.1	0.000039
21	-17.9	-1.2	-0.000040
22	9.2	0.6	0.000021
23	-11.7	-0.7	-0.000026
24	0.0	0.1	0.000002
25	0.0	0.0	0.000001

Maximum Stresses	Tension	Compression
LL8x6x3/4	14.5087	-15.0225
LL4x4x3/4	1.14793	-1.17385

Appendix J: Purlin Analysis of Existing Conditions

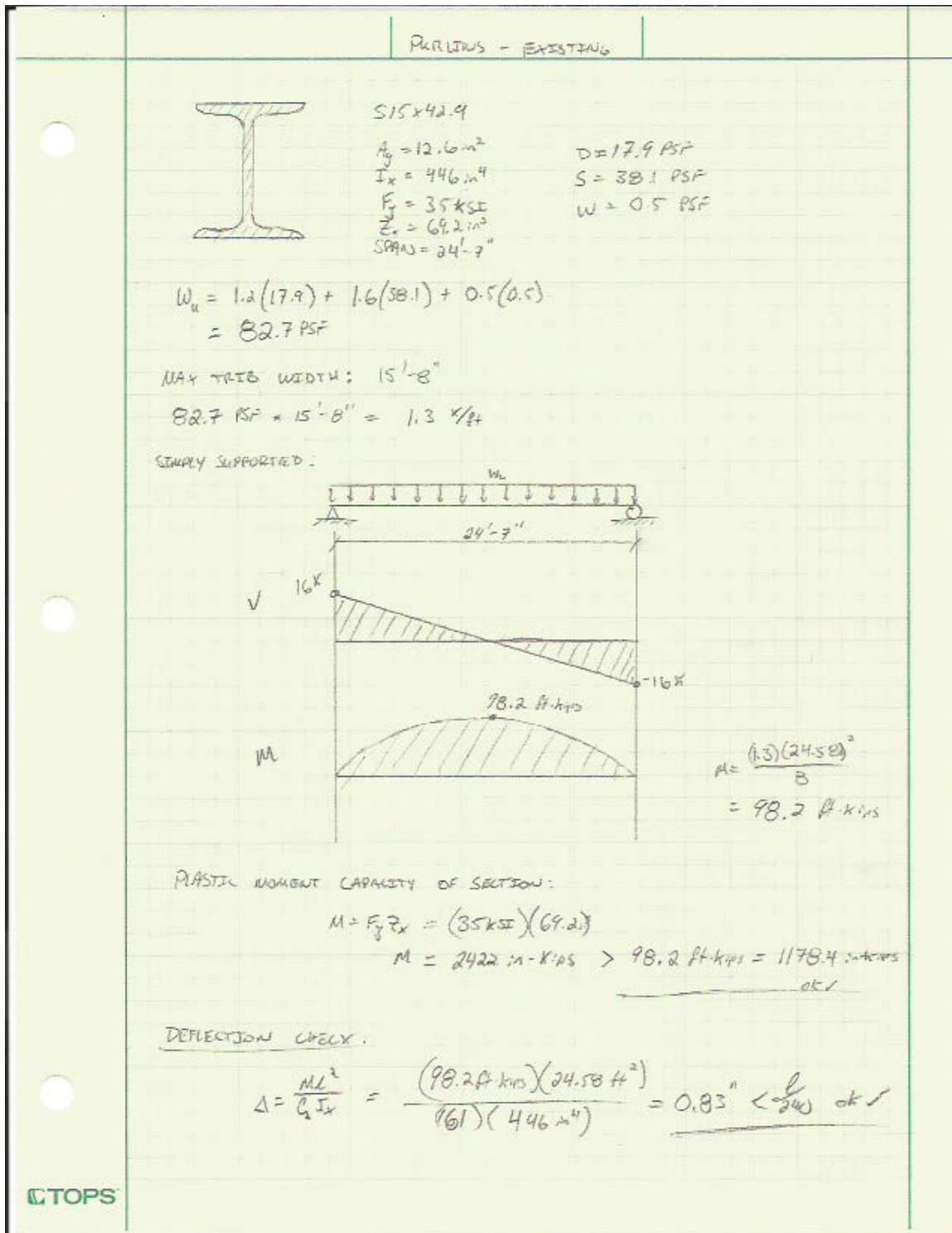

Appendix K: Truss Analysis of Proposed Conditions

Elem	Force (kips)	Stress (ksi)	Strain
1	132.9	6.7	0.000232
2	143.3	7.2	0.000248
3	160.1	8.0	0.000277
4	-289.5	-14.5	-0.000499
5	-306.3	-15.3	-0.000528
6	-316.7	-15.6	-0.000537
7	292.4	15.1	0.000520
8	292.4	14.7	0.000505
9	277.7	13.9	0.000479
10	258.6	12.9	0.000446
11	258.6	13.0	0.000447
12	277.7	13.9	0.000480
13	292.3	14.6	0.000505
14	292.3	14.7	0.000507
15	0.0	0.1	0.000002
16	-13.4	-0.9	-0.000030
17	10.5	0.7	0.000025
18	-20.4	-1.3	-0.000046
19	19.5	1.3	0.000045
20	19.5	1.3	0.000044
21	-20.3	-1.3	-0.000046
22	10.6	0.7	0.000024
23	-13.4	-0.9	-0.000030
24	0.0	0.1	0.000002
25	0.0	0.0	0.000001

Maximum Stresses	Tension	Compression
LL8x6x3/4	15.0674	-15.565
LL4x4x3/4	1.30154	-1.33454

Appendix L: Purlin Analysis of Proposed Conditions

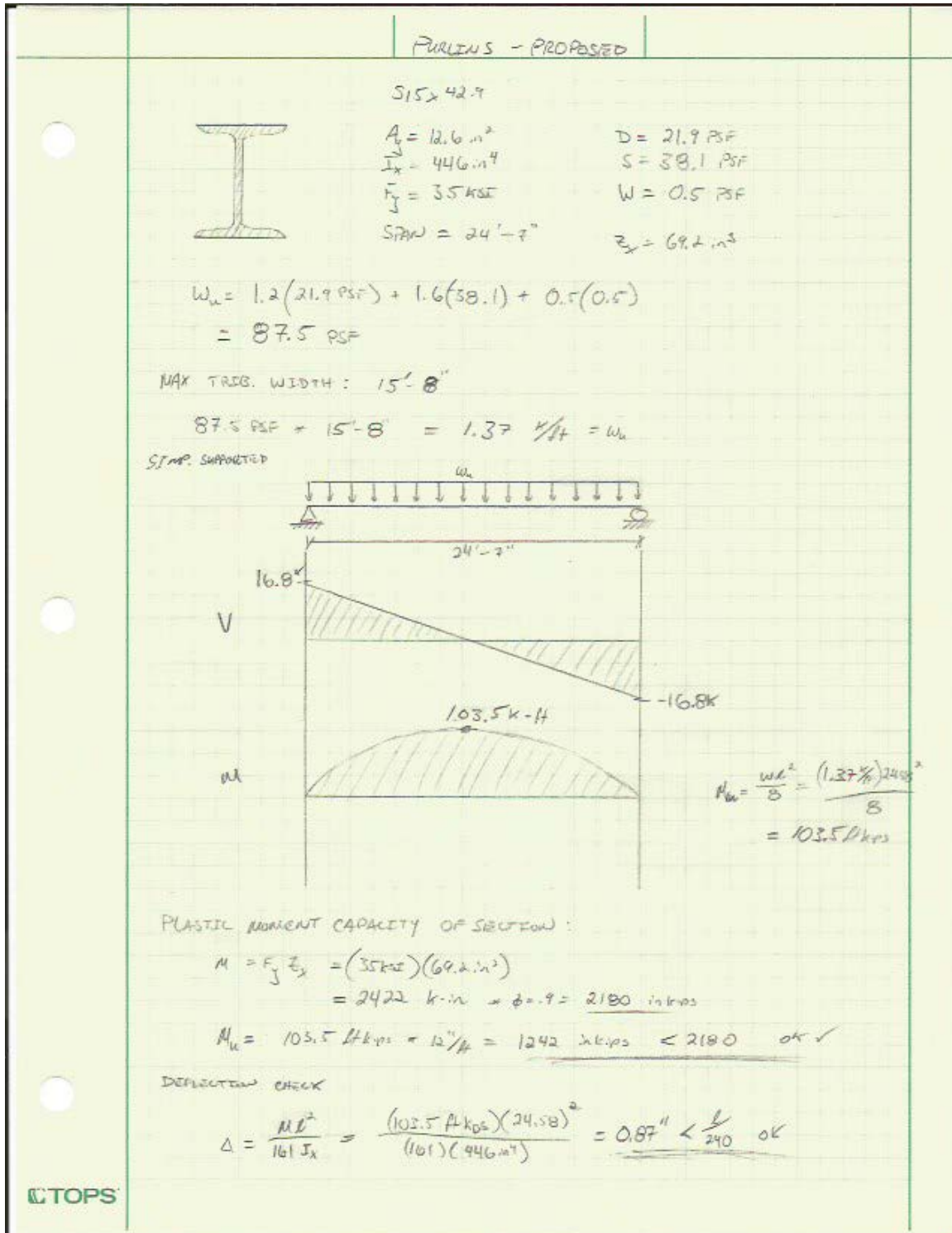

Appendix M: Solar Panel Array Analysis

SOLAR PANEL DESIGN

UPLIFT FORCES

TYPICAL PV DIMENSIONS: 3' x 4'-6"

TYPICAL DEAD WT.: 4 PSF

ROOF CLEARANCE (FROM BD. PANEL TO T.O. ROOF): 5"
- 3 TO 6" TYP.

- 10% LEAST H₂ DRN. = 127' x 10% = 12.7' → = 2
- 0.4*(Bldg. Ht.) = 0.4(54') = 21.6 ft

MAX EXTERNAL PRESSURE COEFF. G_{CF} → ZONE 2E = -1.07

$K_z = 0.83$ $V = 100 \text{ mph}$
 $E_{z0} = 1.0$ $I = 1.15$
 $K_d = 0.85$ $G_{CF} = 0.3 \rightarrow$ CONSERVATIVE (BETWEEN PART ENCLOSED; OPEN)

$q = 0.00256 * 0.83 * 1.0 * 0.85 * 100^2 * 1.15$
 $= 20.76 \text{ PSF}$

DESIGN UPLIFT PRESSURE, P

$P = q (G_{CF} - G_{CFi})$
 $= 20.76 (-1.07 - 0.3) = -28.4 \text{ PSF (UPLIFT)}$

PROPOSED SOLAR PANEL LAYOUT

PLAN VIEW - N.T.S.

OFFSET SOLAR ARRAY'S MIN. 4' FOR MAINTENANCE/INSTALLATION

TOPS

TJL

SOLAR PANEL DESIGN

MONITOR PANELS: 1 ROW OF 35 PANELS

ROOF PANELS: 4 ROWS OF 35 PANELS (140 TOTAL)

AREA PER PANEL = 13.5 SF

UPLIFT FOR MONITOR:

$$(35 \text{ PANELS} \times 13.5 \text{ SF}) (28.4 \text{ PSF UPLIFT}) = 13,419 \text{ LBS.}$$

TWO MOUNTING RAILS \rightarrow 6709.5 LBS. PER RAILCABLE MOUNT \rightarrow PULL OUT STRENGTH OF 23000 LBS

$$n = \frac{6709.5}{3000} = 2.2 \rightarrow 3 \text{ PER RAIL}$$

IRON RIDGE RAILS - 6000 SERIES ALUMINUM - 18 KSI F_y
 $E = 10000 \text{ KSI}$ MID GRADE RAIL \rightarrow XR100 RAIL

$$\text{SELF WEIGHT} = 0.68 \text{ LBS/FT}$$

$$A_g = 0.582 \text{ in}^2$$

$$I_x = 0.390 \text{ in}^4$$

$$S_x = 0.530 \text{ in}^3$$

$$\frac{M}{S} = F_y$$

$$M = F_y S_x = 18 \text{ KSI} (0.530)$$

$$\text{ASD} \rightarrow M_{max} = 9.54 \text{ K IN}$$

$$= 0.795 \text{ K FT}$$

$$W = D + S$$

$$= 4 \text{ PSF} + 38.1 \text{ PSF}$$

$$W = 42.1 \text{ PSF} \times 2.25 \text{ FT} = 95.6 \text{ LBS/FT}$$

$$\text{ALLOWABLE SPAN LENGTH: } M_{max} = \frac{wl^2}{8} \Rightarrow 0.795 = \frac{(0.0956)(l^2)}{8}$$

$$l \leq 8'$$

DEFLECTION @ 8' SPANS

$$\Delta = \frac{5(0.00797 \text{ LBS/IN})(96 \text{ IN})^4}{384(10,000 \text{ KSI})(0.390)} = 2.25'' \rightarrow 700 \text{ MILS}$$

$$\text{LIMIT TO } \approx \frac{1}{4}''$$

$$0.25'' = \frac{5(0.00797)(l^4)}{384(10,000)(0.390)}$$

$$l = 4.6' \rightarrow \text{GOVERNS}$$

SAY 4'-6" SPACING

SOLAR PANELS - SEISMIC

- FULLY FRAMED SYS. - LOAD PATH SAME FOR UPWARD & DOWNWARD FORCES
- WT ANGLES < 10% OF BLDG. WT → NO NEED TO CHECK SEISMIC SYS.

$$\text{IMPORTANCE FACTOR, } I_p = 1.0 \quad (\text{ACE 705 13.1.3})$$

$$S_{OS} = 0.25 \text{ } 3_g$$

$$W_p = \text{COMPONENT OPERATING WEIGHT} = 4 \text{ PSF}$$

$$1 \text{ PANEL} = 3' \times 4.5' = 13.5 \text{ SF} \times 4 \text{ PSF} = 54 \text{ LB/PANEL}$$

$$\frac{W}{W} \geq 1.0$$

$$\left. \begin{array}{l} a_p = 1.0 \\ R_p = 1.5 \end{array} \right\} \text{ OTHER NEGL. \& \text{ ELEC COMPONENTS } (\text{ACE 705 TABLE 13.6-1})$$

$$F_p = \frac{0.4 a_p S_{OS} W_p}{\left(\frac{R_p}{I_p}\right)} \left(1 + 2 \frac{Z}{h}\right) \quad (\text{EQ. 13.5-1})$$

$$F_p = \frac{(0.4)(1.0)(0.25)(54 \text{ lbs})}{\left(\frac{1.5}{1.0}\right)} (1 + 2(1)) = 10.93 \text{ SAY } 11 \text{ lbs. PANEL}$$

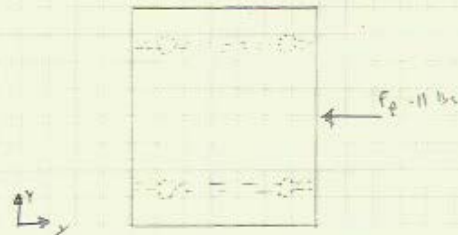

$$35 \text{ PANELS PER ROW} = 385 \text{ lbs } \rightarrow \text{ IN } x \text{ OR } y \text{ DIRECTION}$$

$$\text{MAX SHEAR} \approx 1400 \text{ lbs } \rightarrow \text{ ENL REPORT OK}$$

Appendix N: List of Electronic Files

1. Phase One Model - *Phase1Final.rvt*
2. Phase Two Model - *Phase2AlumniModel.rvt*
3. Phase Three Model - *Phase3AlumniModel.rvt*
4. Infiltration - *Infiltration.xlsx*
5. Thermal Calculations and Cost Benefit -
ThermalCalculationAnalysisAndCostBenefitAnalysis.xlsx
6. Structural Analysis - *Structural Analysis Folder*
 - a. Excel Sheets - *Excel Sheets Folder*
 - i. Weight of Alumni Gym for Seismic - *AlumniGymwtforseismic.xlsx*
 - ii. Alumni Gym Wind Loads - *AlumniWindLoads.xlsm*
 - iii. Wind for Solar Panels - *SolarPanels.xlsm*
 - iv. MATLAB outputs - *LoadingSummaries.xlsx*
 - v. Load Combinations with Solar Panels - *LoadsPV.xlsx*
 - vi. Existing Load Cases - *ExistingLoading.xlsx*
 - b. Hand Calculations - *Hand Calculations Folder*
 - i. Seismic Hand Calculations - *SeismicHandCalcs.pdf*
 - ii. Purlin Hand Calculations - *PurlinHandCalcs.pdf*
 - iii. Solar Panel Connections - *SolarPanelConnections.pdf*
 - iv. Dead (exist.) and Snow Loads - *DeadandSnowLoads.pdf*
 - v. Node/Member Locations for MATLAB - *TrussLayout.pdf*
 - c. Base Mount Engineering Report - *qbasereport.pdf*

7. Green Building Studio Output – *Green Building Studio Output Folder*
 - a. Phase 1 Analysis - *AlumniGymPhase1Analysis.pdf*
 - b. Storage Shed Analysis - *Storage Shed Analysis Folder*
 - i. Test 1: Control Test - *StorageShedControlandRoofInsulation.pdf*
 - ii. Test 2: Improved Exterior Insulation -
StorageShedControlandRoofInsulation(1).pdf
 - iii. Test 3: Effect of the Site Items -
StorageShedStorageShed,surroundedbytrees.pdf
 - iv. Test 4: Proper Orientation of Building to True North -
*StorageShedTest3StorageShedSunPathTurnedOn,RotatedToActual
Location.pdf*
 - v. Test 5: Orientation of Building Rotated 90° Clockwise from Proper
Orientation -
StorageShedStorageShed,Rotated90DegreesClockwise(1).pdf
 - vi. Test 6: Orientation of Building Rotated 180° Clockwise from
Proper Orientation -
*StorageShedTest3StorageShedSunPathTurnedOn,Rotated180Degr
ees.pdf*
 - vii. Test 7: Three Rooms Divided by 7” Wide Partition with 2” Rigid
Insulation -
*StorageShedStorageShed,SinglePartition7.5with2inchrigidPerpend
iculartoparkst.pdf*

- viii. Test 8: Six Equal Rooms Divided by 7" Partition with 2" Rigid
Insulation -
*StorageShedStorageShed,SixRooms,EqualSize,7.5inchWall2inrigid.
pdf*
- ix. Test 9: Six Equal Rooms Divided by 5.5" Partition with No
Insulation -
*StorageShedStorageShed,SixEqualRooms,5.5inchwallsnoinsul(1).p
df*
- x. Test 10: Simulation Building Type Changed from Warehouse to
Workshop -
StorageShedTest3StorageShedasWorkshopnotwarehouse.pdf
- xi. Test 11: Existing Garage Door Replaced with Curtain Wall -
*StorageShedTest3StorageShedCurtainWallRatherthanGarageDoor
.pdf*