

Project Number: JYP 1302

# **Reclamation of Power in Wastewater Treatment Facilities**

**A MAJOR QUALIFYING PROJECT SUBMITTED TO THE FACULTY OF  
WORCESTER POLYTECHNIC INSTITUTE**

In partial fulfillment of the requirements for the Degree of Bachelor of Science

Submitted by:

Marissa Capua

Jessica Dzwonkoski

Christopher Harris

Advisor:

Jeanine D. Plummer

Date: March 7, 2014

## ABSTRACT

This project explored the feasibility of implementing hydroelectric turbine systems in wastewater treatment facilities in Massachusetts. An inventory of treatment plant information was obtained, and the Upper Blackstone Water Pollution Abatement District in Millbury, MA was selected for a case study analysis. Based on flow and head data, 19.9 kW of power could be produced, generating 1.1% of the facility's electricity needs; however, the available head was slightly below the turbine specifications. Payback periods were calculated to determine hydropower feasibility for other Massachusetts plants, and 30.9% were potentially feasible based on flow but depending on head.

## CAPSTONE DESIGN

This Major Qualifying Project evaluated the feasibility of energy reclamation at existing Wastewater Treatment Facilities by means of a hydroelectric turbine in the effluent channel of a plant. Large plants around the country and New England, such as Deer Island Wastewater Treatment Plant, have already found ways to use renewable energy. Upper Blackstone Water Pollution Abatement District (UPWPAD) was used as a case study for this project.

First, flow data and the hydraulic profile of UPWPAD were gathered and used to calculate power generation in kilowatt-hours. Flow and head were the parameters needed to find an appropriate hydroelectric turbine for this scenario.

Cost-effective hydroelectric turbines for use in wastewater plant were evaluated on payback periods. The Toshiba Hydro-eKIDS turbine was selected for this case since it allowed for low head scenarios.

A cost analysis was conducted for the UBWPAD. This analysis considered the turbine cost, piping cost, concrete cost, labor cost, and a project contingency cost, and it showed a payback period of 2.84 years. However, the available head at the facility was slightly below the turbine specifications and therefore further analysis would be needed to determine feasibility. Lastly, payback periods were calculated for hypothetical combinations of flow and head to demonstrate potential feasibility of implementing hydroelectric power recovery at other wastewater treatment plants.

This MQP fulfilled the requirements of a major capstone design experience. This project included project management operations, as the primary topic for this project was to perform a feasibility study. This project also considered sustainability as part of the design by analyzing the use of a parallel pipe system to house a turbine and reclaim energy that would be wasted otherwise. Lastly, this project considered economic elements by developing cost estimation and generating tables for different head and flow cases.

## EXECUTIVE SUMMARY

Total energy production and consumption in the United States have increased substantially since the middle of the twentieth century. In 1949, both consumption and production were approximately 32 quadrillion Btu. By 2011, production reached 78 quadrillion Btu (144% increase), while consumption reached over 97 quadrillion Btu (203% increase) (U.S. Energy Information Administration, 2012). Of the energy consumed in the U.S. in 2011, 79.8% came from fossil fuels (petroleum, coal, and natural gas) (U.S. Energy Information Administration, 2011). Fossil fuels emit polluting byproducts that cause environmental and health issues, and the resources are finite. Renewable energy helps to address emission problems through sustainable energy production from wind, hydroelectric, and solar sources.

Hydropower is a form of renewable energy that is harnessed from the movement of water. A hydroelectric turbine converts kinetic energy from the moving water into mechanical energy, which powers an electrical generator. The electrical energy is transmitted to an electrical grid for distribution. Hydropower systems can be designed to use moving waters, storage dams, or using pumped storage. Moving water can be found naturally in rivers, streams, and oceans, and also in man-made conduits where water is flowing constantly. The wastewater treatment facility at Deer Island in Boston, MA installed hydropower systems in 2002 to generate 5.1% of the electricity that is used at Deer Island per year. However, few facilities in the United States reclaim energy through turbines.

The goal of this project was to conduct a study on the feasibility of installing a hydroelectric turbine system into the effluent pipe of a wastewater treatment facility. This study included calculating the amount of potential power generated from a turbine, selecting an appropriate turbine, designing a new effluent pipe to house the turbine, and executing a cost analysis. These tasks were completed by performing a site-specific case study. Following this study, the analysis was extended to various flow conditions.

The case study was performed on the Upper Blackstone Water Pollution Abatement District (UBWPAD) in Millbury, MA to explore the feasibility of the turbine installation. This plant discharges to the Blackstone River. Hydraulic data (chlorine contact chamber dimensions, weir height, and flow data), the available head, and average electricity costs per month were obtained from the plant manager. Yearly power potential was calculated based on the average flow and head under normal river conditions. With an available head of 5.6 feet and an average flow volume of 32 million gallons per day, a hydroelectric turbine of 85% efficiency at the UBWPAD would have the potential to generate 19.9 kilowatts of electricity. The electricity generated would make up about 1.1% of the electricity that is consumed at this facility.

The next task was the selection of appropriate turbine and the design of the effluent structure to incorporate the turbine. The Toshiba Hydro-eKIDS micro turbine was selected because it is

relatively inexpensive compared to similar turbines manufactured by other companies, and it accommodates the 32-MGD flow rate at the UBWPAD. A separate, enclosed pipe was designed to channel the flow into the turbine for maximum efficiency. The piping material, smoothed cement, was selected based on the friction losses due to material roughness, cost, and durability. A wall was implemented into the entrance of the existing effluent pipe in order to divert the flow into the new effluent pipe containing the turbine.

A preliminary cost analysis was completed to include the cost of the turbine and generator system, the cost for new piping structures, and the cost of the concrete slab upon which the new pipe and turbine would rest. The Toshiba Hydro-eKIDS turbines' costs can range from \$7,000 to \$30,000 (including installation costs) depending on the selected turbine size, this case study required the largest turbine therefore the price was assumed to be \$30,000. The cost for the concrete foundation (\$242) was determined based on the required dimensions of the slab, which were dependent on the size and weight of the turbine. Piping costs were determined based on the average cost per foot of a 4-foot diameter smoothed concrete pipe, and totaled \$9,380, for a 35' pipe. With a 25% contingency for unexpected costs that may occur during construction, the total cost estimate was \$49,500. State and Environmental Protection Agency funding may be available for small hydroelectric projects.

The next objective was to calculate how much money the plant would save each year based on the amount of power produced and sold to the grid. This value was compared with cost to purchase the total amount of electricity consumed at the plant each year. The UBWPAD could potentially generate up to 19.9 kW (approximately 174,000 kWh) of electricity per year. Selling it back to the grid at \$0.10 per kWh, the UBWPAD could save approximately \$17,400 on electricity costs each year. Thus the payback period would be 2.84 years.

While the UBWPAD case study analysis appeared favorable, the head at the plant was slightly below the minimum turbine specifications. The final goal of this project was to extend the analysis performed at the UBWPAD to other wastewater treatment facilities. Hypothetical flow and head cases of 2-46 million gallons per day and 6-50 feet (respectively) were analyzed. The flow cases were based off of those at the different wastewater treatment facilities in Massachusetts; however, the available head at these facilities was not provided, so hypothetical head cases were based off of the applicable head specifications of the selected turbine. A total of 299 hypothetical flow and head combinations were analyzed, and 86.3% of these cases were determined to be feasible based on their payback periods. Massachusetts wastewater facilities may refer to these hypothetical cases to determine the feasibility of implementing this hydropower project at their facilities.

This study concluded that there are many facilities that would have the potential to implement hydropower technology into pre-existing systems. This technology, as well as other renewable

energy technologies, offers a way for wastewater treatment plants to become more self-sufficient in green energy production and consumption.

## TABLE OF CONTENTS

ABSTRACT.....	ii
CAPSTONE DESIGN .....	iii
EXECUTIVE SUMMARY .....	iv
LIST OF FIGURES .....	ix
LIST OF TABLES .....	x
1. RENEWABLE ENERGY.....	1
1.1 Renewable Energy in the United States .....	3
1.2 Hydropower.....	4
1.2.1 Run of River Hydropower Systems.....	5
1.2.2 Storage Hydropower Systems .....	7
1.2.3 Pump Storage Hydropower Systems .....	7
1.3 Hydroelectric Power at Treatment Plants.....	8
1.4 Hydroelectric Power Feasibility in Wastewater Treatment Plants in MA .....	10
2. INVENTORY OF WASTEWATER TREATMENT FACILITIES .....	11
2.1 Wastewater Treatment Facility Inventory.....	11
2.2 Selection of Facility for Case Study Analysis.....	12
3. CASE STUDY: UPPER BLACKSTONE WATER POLLUTION ABATEMENT DISTRICT .....	13
3.1 UBWPAD Overview.....	13
3.2 Potential Power Output .....	14
3.3 Turbine Selection .....	17
3.4 Design Considerations.....	22
3.5 Piping Material Selection.....	23
3.6 Operational and Maintenance Considerations.....	27
4. ECONOMICS .....	28
4.1 System Installation Costs at UBWPAD.....	28
4.1.1 Turbine and Generator System.....	29
4.1.2 Piping.....	29
4.1.3 Concrete.....	29

4.1.4 Contingency .....	29
4.2 Electricity Benefit .....	30
4.2.1 Consumption Costs to Facility .....	30
4.2.2 Production from Hydropower.....	30
4.3 Payback Period.....	30
4.4 Permits, Regulations, and Incentives .....	31
5. EXTENDED ANALYSIS USING HYPOTHETICAL FLOW AND HEAD CASES .....	33
5.1 Hypothetical Flow and Head Cases .....	33
5.2 Feasibility of Hypothetical Hydropower Scenarios .....	33
5.3 Feasibility of Massachusetts Wastewater Treatment Facilities.....	35
6. CONCLUSIONS AND RECOMMENDATIONS .....	36
6.1 Feasibility at UBWPAD.....	36
6.2 Feasibility at Other Wastewater Treatment Plants.....	36
6.3 Recommendations .....	37
6.3.1 Deer Island Energy Reclamation.....	37
6.3.2 Potential for Energy Reclamation at UBWPAD .....	37
BIBLIOGRAPHY.....	39
Appendix A: Deer Island Electricity Usage.....	44
Appendix B: Massachusetts Municipal Wastewater Treatment Plants .....	46
Appendix C: UBWPAD Influent Flow Data .....	71
Appendix D: Manufacturer Information.....	73
Appendix E: Solid Model Drawings.....	88
Appendix F: Hypothetical Case Tables .....	92



## LIST OF FIGURES

Figure 1 - U.S. Total Energy Consumption and Production from 1950-2010 (Adapted from U.S. Energy Information Administration, 2012).....	1
Figure 2 - Projected Growth of Electricity Generation by Source (Adapted from U.S. Energy Information Administration, 2013) .....	2
Figure 3 - Primary U.S. Energy Consumption by Sector (a) and Source (b), 2011 (Adapted from U.S. Energy Information Administration, 2011).....	3
Figure 4 - Schematic of Run-of-River Project (Adapted from AltaGas Ltd., 2014) .....	6
Figure 5 - Schematic of a Hydroelectric Dam (Adapted from Combs, 2008).....	7
Figure 6 - Schematic of Pump Storage (Adapted from Federal Energy Regulatory Commission, 2014) .....	8
Figure 7 - Deer Island Treatment Plant Improvement Plan (Adapted from Massachusetts Water Resources Authority, 2013).....	9
Figure 8 - Variations in Flow Rate through Sewer System at UBWPAD throughout 24-Hour Period (Adapted from UBWPAD Data Found in Appendix C).....	16
Figure 9 - Horizontal Hydro-eKIDS L-Type Turbine (Adapted from United States Environmental Protection Agency, 2013) .....	21
Figure 10 - Model of Chlorine Contact Chamber at UBWPAD and Redesigned Effluent. ....	22
Figure 11 - The Moody Diagram (Unaltered from Diagramme, 2013).....	25
Figure 12 - Potential Energy Reclamation Systems at UBWPAD .....	38

## LIST OF TABLES

Table 1 - Primary U.S. Energy Consumption by Source and Sector, 2011 (Adapted from U.S. Energy Information Administration, 2011) .....	4
Table 2 - Timeline of Growing Use of Hydropower in the United States (Adapted from U.S. Department of Energy, 2011) .....	5
Table 3 - Deer Island Total Electricity Consumption and Hydropower (Adapted from Massachusetts Water Resources Authority, 2013) .....	9
Table 4 - Grouped Wastewater Treatment Facilities in Massachusetts .....	11
Table 5 - Facility Information.....	12
Table 6 - Change in Water Density with Respect to Temperature .....	15
Table 7 - Power Potential Based on Available Head at UBWPAD.....	17
Table 8 - Power Potential for Varying Flow Rates for UBWPAD.....	17
Table 9 - Turbine Operational Head Specifications .....	18
Table 10 - Micro Turbine Model Specifications (United States Environmental Protection Agency, 2013).....	20
Table 11 - Dimension Specifications of Toshiba Micro Turbines (Adapted From Toshiba Corporation et al., 2014) .....	21
Table 12 - Frictional Characteristics of Different Piping Materials .....	26
Table 13 - Estimated System Installation Costs for UBWPAD (Waier, 2011) .....	28
Table 14 - Feasibility Chart for Varying Hypothetical Flow and Head Cases .....	34
Table 15 - UBWPAD Wastewater Influent Flow Data .....	72
Table 16 - Potential Power Generation (kWh) of Hypothetical Flow and Head Cases.....	93
Table 17 - Annual Savings for Hypothetical Flow and Head Cases.....	94
Table 18 - Payback Periods (Years) of Hypothetical Flow and Head Cases.....	95

## 1. RENEWABLE ENERGY

Within the last century, the use of energy worldwide has grown significantly. In developed countries such as the United States, both consumption and production have dramatically increased, as displayed in Figure 1. From 1950 to 2010, energy production in the U.S. has more than doubled, from just over 30 quadrillion Btu to nearly 80 quadrillion Btu. Energy consumption has tripled from just over 30 quadrillion Btu to just under 100 quadrillion Btu.

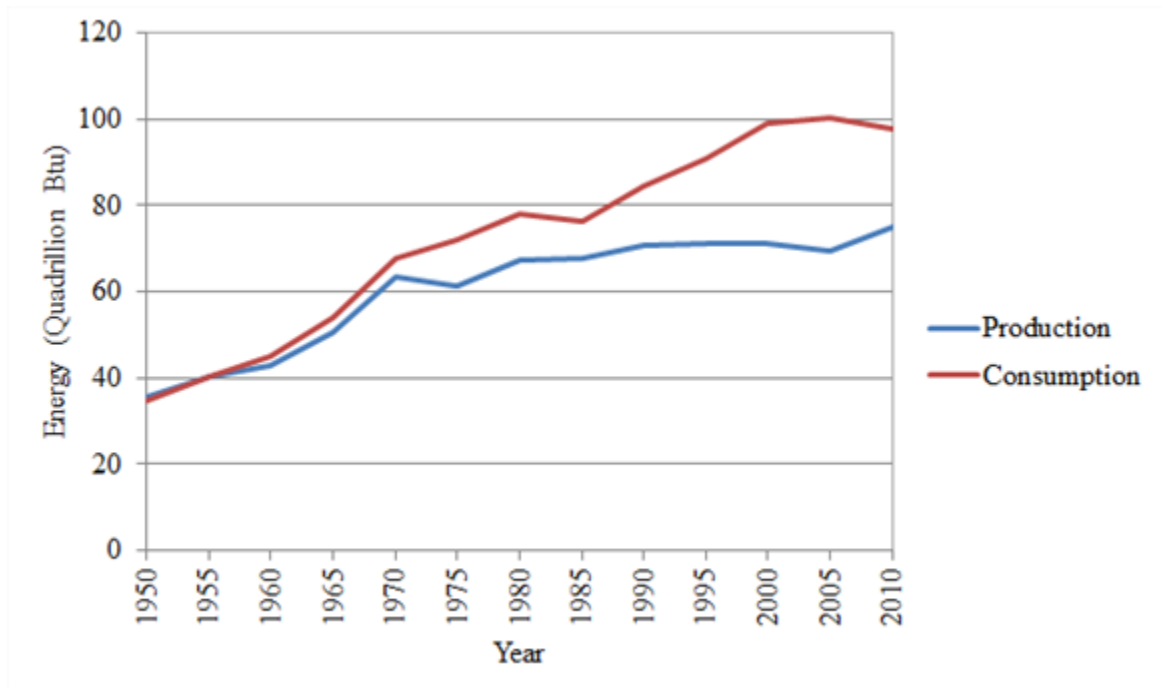

*Figure 1 - U.S. Total Energy Consumption and Production from 1950-2010 (Adapted from U.S. Energy Information Administration, 2012)*

Coal, natural gas, and oil became the primary energy sources because these sources are abundant in supply for the mass production of energy, which is able to support a large population. However, these sources are considered non-renewable; the rate at which the sources are created is much slower than the rate at which they are consumed. According to the United States reserves-to-production ratio for 2010, U.S. supplies of oil are expected to be exhausted in 11.3 years, natural gas in 12.6 years, and coal in 241 years (Energy Realities, 2013). These non-renewable sources also have harmful effects on the environment, putting environmental sustainability for future generations at risk. These harmful effects may include climate change, acid rain, oil spills, and the deterioration of air, water, and soil quality (Union of Concerned Scientists, 2002).

The development of new technologies, in combination with old techniques, brought about the idea to harness energy using renewable sources and processes naturally provided by the earth.

For example, the harnessing of wind energy dates as far back as 5000 B.C. with the propulsion of boats on the Nile River, followed by the invention of windmills for pumping water and grinding grains by 200 B.C. (U.S. Department of Energy, 2011). Industrialization in Europe led to the development of the first electricity-generating wind turbine in Denmark in 1890 (U.S. Department of Energy, 2011). Additionally, energy from moving water was harnessed for grinding wheat into flour over 2,000 years ago, eventually leading to the operation of the world’s first hydroelectric power plant on the Fox River in Appleton, WI in 1882 (U.S. Department of Energy, 2011).

Renewable energy sources — coming from flowing water, moving winds, sunlight, and more — are increasing in use to harness energy in an effort to provide a more sustainable future. Figure 2 illustrates the projected growth of the generation of electricity from various energy sources in the United States. By the year 2000, renewables accounted for 9% of electricity generation — approximately 340 billion kilowatt hours. In 2012, these sources generated 12% of the country’s electricity. The U.S. Energy Information Administration predicts that by the year 2040, renewable energy sources will generate 16% of the electricity produced in the United States. That is about 830 billion kilowatt hours of electricity, and 2.4 times more electricity generated by renewable sources than in 1990 (U.S. Energy Information Administration, 2013).

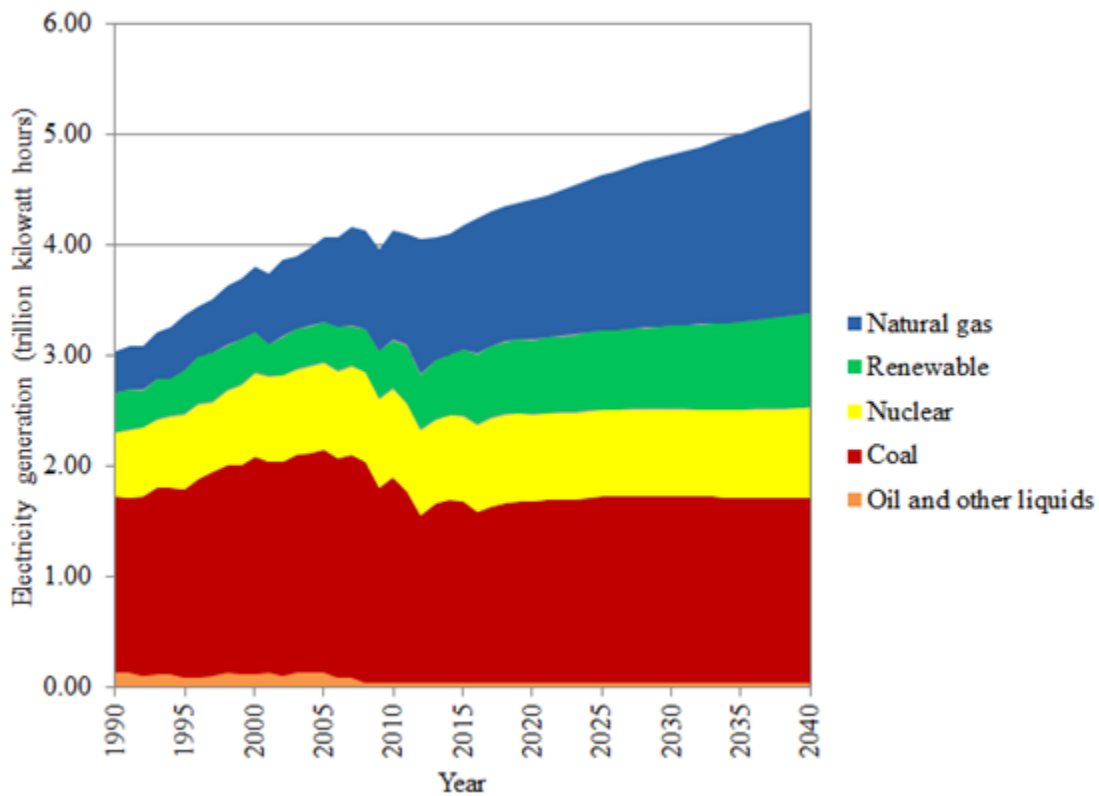

Figure 2 - Projected Growth of Electricity Generation by Source (Adapted from U.S. Energy Information Administration, 2013)

## 1.1 Renewable Energy in the United States

Figure 3 outlines the energy consumption in the United States by source and sector for 2011. As shown, renewable energy makes up 9% of the total energy consumed in the U.S., while coal, natural gas, and petroleum comprise approximately 80% of U.S. energy. Of the renewable energy that is consumed, 54% is consumed by the power industry. Considering all electric power sources, renewable energy accounts for 13% of the total power sources, while the remaining percentage comes from petroleum, natural gas, coal, and nuclear energy.

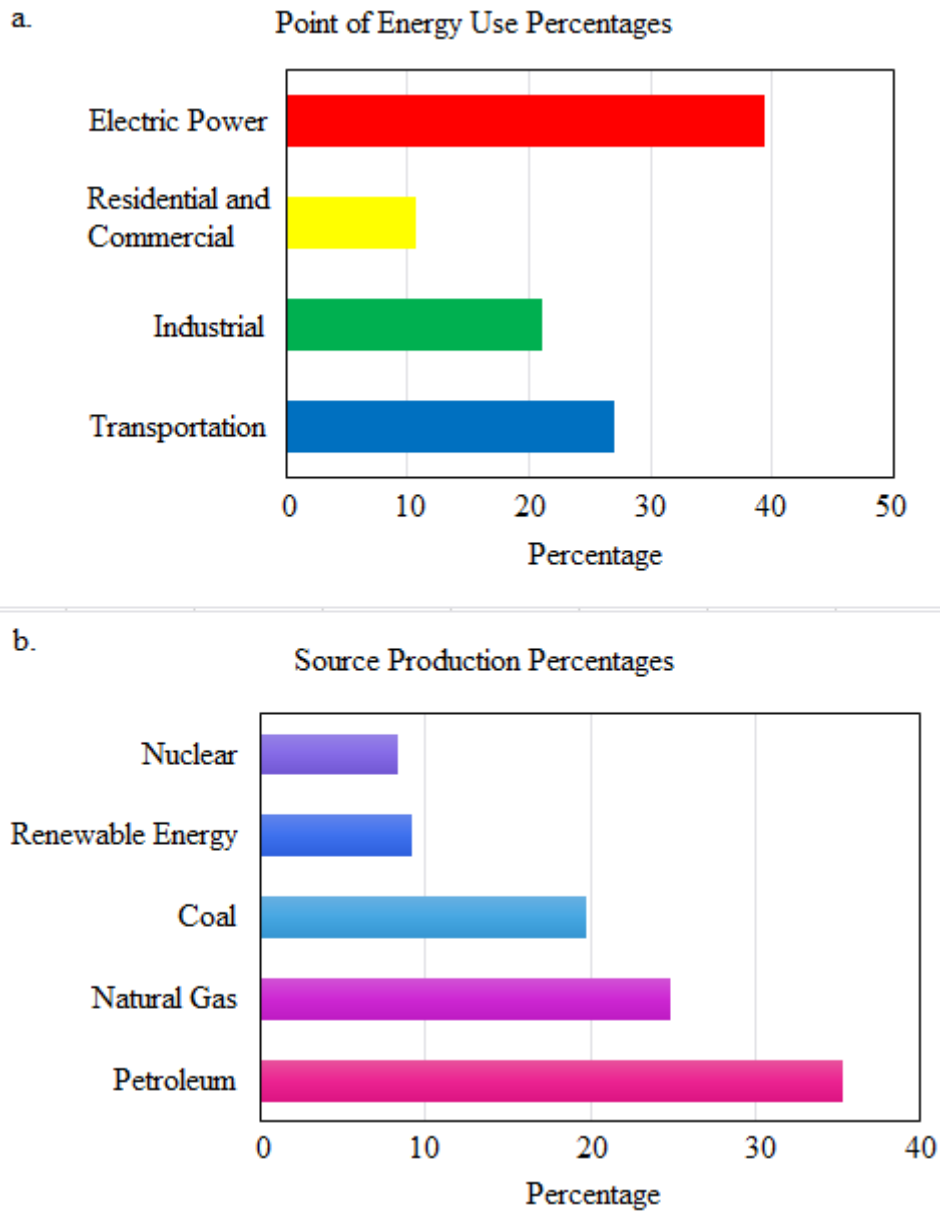

Figure 3 - Primary U.S. Energy Consumption by Sector (a) and Source (b), 2011 (Adapted from U.S. Energy Information Administration, 2011)

Renewable energy can be broken down into multiple categories. Wind, solar, and hydropower are the most commonly known examples of renewable energy sources, but there is also geothermal energy, biofuels, and more. Of these sources, hydroelectric power generates the majority of renewable energy, as shown in Table 1, while the rest is made up by wood, biofuels, wind, waste, geothermal, and solar power.

*Table 1 - Primary U.S. Energy Consumption by Source and Sector, 2011 (Adapted from U.S. Energy Information Administration, 2011)*

<i>Renewable Energy Source</i>	<i>Share of Total Primary Energy Consumption (%)</i>
Solar/Photovoltaic	2
Geothermal	2
Waste	5
Wind	13
Biofuels	21
Wood	22
Hydroelectric Power	35

## **1.2 Hydropower**

A commonly known and used form of renewable energy is hydropower, which generates power using the kinetic energy of moving water. Table 2 outlines historical highlights of hydropower usage since the development of the world’s first hydropower plant in 1882. Today, hydropower systems are utilized in rivers, reservoirs, and sometimes oceans.

The drop in percentage of U.S. electricity generated by hydropower from 1940 to 2003 can be attributed to the rapid growth of other energy sources. From 1949 to 2011, the production of electricity from coal and natural gas increased by 85% and 337%, respectively, while electricity produced from hydropower grew by 123%. Total energy production has increased by nearly 150% (U.S. Energy Information Administration, 2011).

Hydropower systems operate with the use of a water turbine, which is selected based on different values of flow rate and drop height, or head. Kinetic energy in the form of falling water moves through the turbine, converting it to mechanical energy as the turbine spins. The spinning turbine

powers an electric generator, and a transformer then converts the voltage from the generator into mains voltage, producing electrical energy.

*Table 2 - Timeline of Growing Use of Hydropower in the United States (Adapted from U.S. Department of Energy, 2011)*

<i>Year</i>	<i>Event</i>
1882	Operation of world's first hydroelectric power plant begins on Fox River in Appleton, WI
1886	About 45 hydroelectric power plants in operation in the U.S. and Canada
1889	Hydropower used for some or all electricity generation in 200 U.S. power plants
1907	15% of U.S. electricity generated by hydropower
1920	25% of U.S. electricity generated by hydropower
1937	Operation of Bonneville Dam begins on Columbia River (first Federal dam)
1940	40% of U.S. electricity generated by hydropower
2003	10% of U.S. electricity generated by hydropower

Power generated in hydropower systems can be calculated using Equation 1 (De Vooght, 2013):

$$P = \eta\rho_w gQH \quad \text{(Equation 1)}$$

Where:

- $P$  is power (kW)
- $\eta$  is the efficiency of the turbine (unitless)
- $\rho_w$  is the density of the water ( $\text{kg/m}^3$ )
- $g$  is the acceleration due to gravity ( $\text{m/s}^2$ )
- $Q$  is the flow of water through the turbine ( $\text{m}^3/\text{s}$ )
- $H$  is the head (m).

Different types of hydropower systems are used based on the flow behavior of water. These systems are further described in sections 1.2.1 through 1.2.3.

### 1.2.1 Run of River Hydropower Systems

Run-of-river power turbines utilize the natural flow of water down a river, and they can operate with essentially zero head. With a low head, the amount of power is more dependent on the flow of the river and the velocity through the turbine. Run-of-river turbines work best on rivers with a

steep grade or large streams where flow is confined in a narrow area. A narrow riverbed will cause the water to flow more quickly and with greater force, due to an increase in pressure (Combs, 2008). A schematic of a run-of-river project is shown in Figure 4.

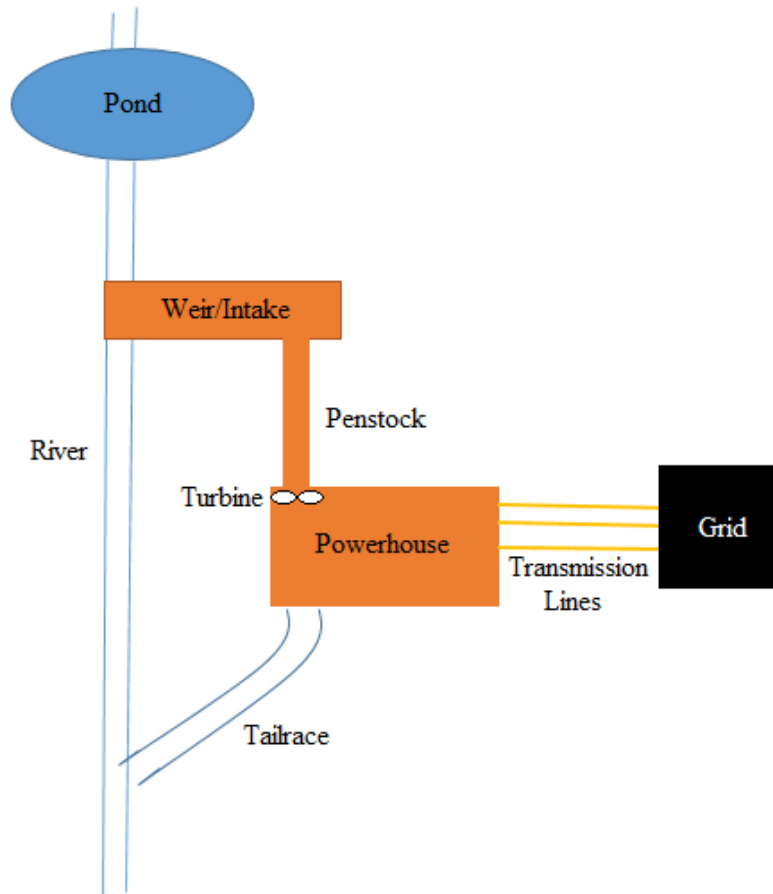

*Figure 4 - Schematic of Run-of-River Project (Adapted from AltaGas Ltd., 2014)*

In Figure 4, the penstock — also known as the intake channel — is where the water is channeled into the turbine. The tailrace is where the water that flows through the turbine exits the plant and discharges to the river. This is also known as the outlet.

Because the water naturally loses its potential energy as it flows down a river, run-of-river hydropower systems harness less power than other types of hydropower systems (Freris & Infield, 2008). The Bonneville Dam on the Columbia River, the first Federal dam in the United States, uses a series of run-of-river hydroelectric turbines in order to generate electricity in the Pacific Northwest. The dam has two powerhouses at separate parts of the river. The first powerhouse was completed in 1938, and it contains ten generators that produce 660 megawatts of electricity. Construction of the second powerhouse was completed in 1981, producing an additional 558 megawatts of electricity from its eight generators (U.S. Army Corps of



Engineers).

### 1.2.2 Storage Hydropower Systems

Storage hydropower plants, typically in the form of a dam, are able to generate larger amounts of power output than run-of-river hydropower systems. These dams take advantage of both a large head and the volume of stored water in the reservoir to create pressure on the water flowing through its turbine. Figure 5 depicts the basic schematics of a dam and how the water flows from the intake through the turbine and into the river. A dam similar to the figure is present in Holyoke, MA, spanning the width of the Connecticut River. This dam was initially built in 1848, but following construction, the dam's flood gates were closed, and the river exerted too much force on the dam, resulting in its destruction. A second construction attempt was successfully made in 1876, and the dam provided 22 megawatts of electricity to the multiple paper mills located in the city (O'Donnell, 1876).

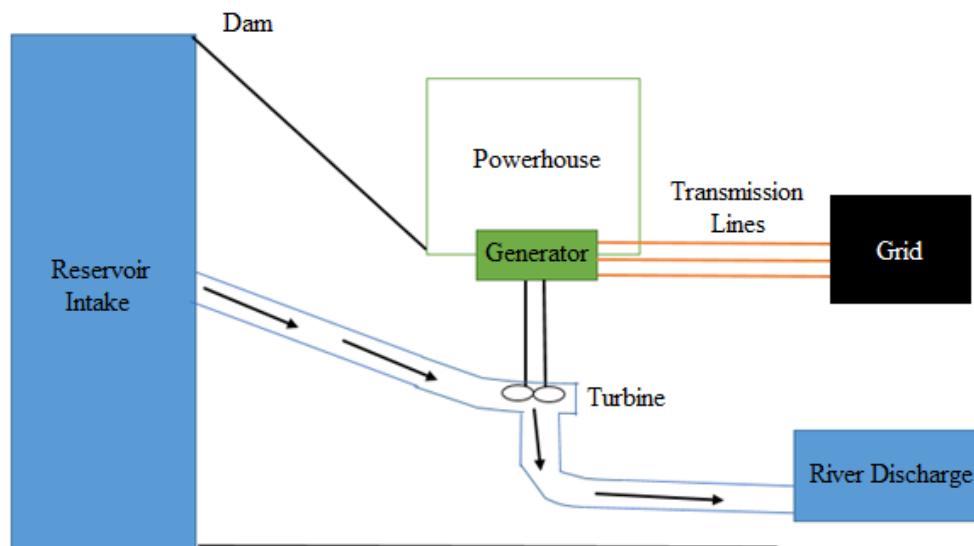

*Figure 5 - Schematic of a Hydroelectric Dam (Adapted from Combs, 2008)*

### 1.2.3 Pump Storage Hydropower Systems

Another way to generate hydroelectric power is through the process of pump storage. A pump storage system requires two reservoirs at different elevations. Using excess electric generation capacity, the water is pumped from the lower reservoir to the upper reservoir during hours of low demand for electricity. When the electrical demand is high or at its peak, the water is released through a turbine from the upper reservoir to the lower reservoir. Figure 6 shows a diagram of how a pump storage system works (Federal Energy Regulatory Commission, 2014).

One example of a large pump storage plant in the United States today is the Ludington Pump Storage Plant located in Ludington, MI. The plant uses six turbines that also act as pumps. When electricity demand is low — typically overnight — the turbines pump water from Lake Michigan

uphill to a 27-billion-gallon reservoir. During the daytime when demand for electricity is high, the water flows 363 feet downhill through the six turbines in order to generate electricity. The plant can currently produce up to 1.872 megawatts of electricity (Consumers Energy *et al.*, 2006).

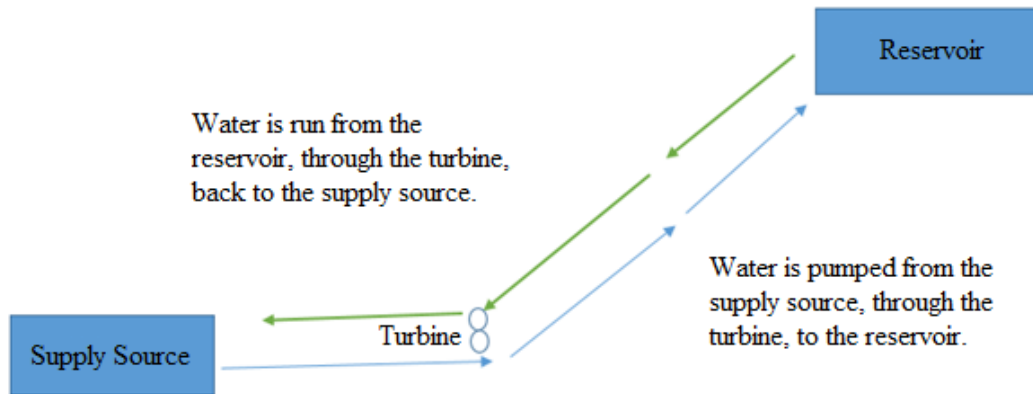

Figure 6 - Schematic of Pump Storage (Adapted from Federal Energy Regulatory Commission, 2014)

### 1.3 Hydroelectric Power at Treatment Plants

The implementation of hydroelectric power in wastewater plants is primarily in the developmental stages. Few plants have implemented this technology to date, but the potential exists for some facilities to do so. For example, the Deer Island Wastewater Treatment Plant located in Boston, MA uses multiple power reclamation systems, generating 26% of the plant's electricity needs through renewable resources. The reclamation systems include steam turbine generation, methane gas reuse, solar power, wind power, and hydropower as seen in Figure 7 (Massachusetts Water Resources Authority, 2013).

The Deer Island Wastewater Treatment Facility was designed in 1980 with future energy recovery processes in mind. This facility has been recovering energy from effluent flow since 2002. Currently the water flows out of the plant into an outfall shaft through two one-megawatt hydroelectric generators. These generators produce over 6 million kilowatt hours annually, which saves the facility approximately \$600,000 per year.

Each year, the Massachusetts Water Resource Authority (MWRA) purchases and uses 168,500,000 kWh of electricity, with Deer Island accountable for 70% of the electricity consumption. Deer Island uses a total of 117,950,000 kWh and produces 6 million kWh through hydroelectric generation, a return of 5.1% of the total electricity usage at the plant. The calculations for Deer Island's electricity usage and the percent of hydropower contribution can be found in Appendix A.



Figure 7 - Deer Island Treatment Plant Improvement Plan (Adapted from Massachusetts Water Resources Authority, 2013)

Table 3 - Deer Island Total Electricity Consumption and Hydropower (Adapted from Massachusetts Water Resources Authority, 2013)

Category	kWh	Percentage of Total MWRA
Total MWRA Electricity Purchased Annually	168,500,000	100
Deer Island Electricity Consumption	117,950,000	70
Deer Island Hydropower Electricity Generation	6,000,000	3.6

Another example of hydropower at wastewater treatment facilities exists in Point Loma, San Diego, CA. This facility utilizes hydroelectric turbines in its effluent flow to generate up to 1.35 megawatts of electricity, which is then sold to the San Diego Gas and Electric Company (United States Environmental Protection Agency, 2013).

## 1.4 Hydroelectric Power Feasibility in Wastewater Treatment Plants in MA

There are 110 municipally owned wastewater plants located in Massachusetts, treating flows that range from 0.02 million gallons per day to 365 million gallons per day (U.S. Environmental Protection Agency-New England, 2011). The water flowing through these treatment plants provides a potential source of energy that may be reclaimed and transformed into electricity. The purpose of this project was to determine the feasibility of implementing a hydroelectric turbine system in the effluent of municipal wastewater treatment facilities in Massachusetts. The electricity generated from the system may then be used to contribute to the demand of the treatment plant either through net metering or by selling the electricity back to the supplier.

Some states allow for commercial and industrial facilities to establish net metering. This allows facilities to feed electricity into the grid and establish a credit with the supplier. A facility is then allowed to pull electricity from the grid until the credit has expired (Solar Energy Industries Association, 2014). Massachusetts currently has a net metering program for most renewable energy technologies, including hydroelectric power generation, for a variety of sectors (U.S. Department of Energy *et al.*, 2013). This program allows for renewable energy technologies to install a net metering system to record the amount of energy produced and subtract it from the amount of energy consumed.

In order to determine the feasibility of implementing hydroelectric power at wastewater treatment facilities, the following tasks were completed:

- Inventory wastewater treatment facilities in Massachusetts and select facility for case study
- Perform case study analysis on selected facility
  - Gather information on monthly electric costs
  - Gather data on hydraulic profile and daily flow
  - Analyze cost of equipment, construction, maintenance, permits, and labor versus payback period
- Extend analysis to other treatment plants using hypothetical cases of head and flow

The overall goal was to make recommendations for hydropower implementation based on the treatment plant flow, head, costs, and payback period so that facilities are able to make informed decisions about whether or not the turbine installation would be a feasible project and worthwhile investment.

## 2. INVENTORY OF WASTEWATER TREATMENT FACILITIES

The first step in conducting a feasibility study is to gain information that is site-specific, followed secondly by creating an estimate of the power potential, and thirdly by conducting an economic analysis. This standard of conducting a feasibility study is validated by the U.S. Department of Agriculture (Brockhouse *et al.*, 2010). Before proceeding with the feasibility study, a wastewater treatment facility in Massachusetts was to be selected for analysis. In order to select a treatment plant, an inventory of systems in Massachusetts was compiled, and then a facility was selected based on size, location, and data availability.

### 2.1 Wastewater Treatment Facility Inventory

Specific information about registered wastewater treatment plants in the state of Massachusetts was obtained from the Environmental Protection Agency (U.S. Environmental Protection Agency-New England, 2011). As shown in Appendix B, available information included the plant name, location, contact information, and permit number. Additionally, information on treatment processes, flow, and discharge location were provided. There are 110 treatment plants in Massachusetts, with average daily flows ranging from 0.016 to 365 million gallons per day. The facilities were grouped into 6 categories based on daily flows as shown in Table 4.

*Table 4 - Grouped Wastewater Treatment Facilities in Massachusetts*

<i>Flow Range (MGD)</i>	<i>Number of Treatment Plants</i>	<i>Percentage of Treatment Plants</i>	<i>Number of Plants Contacted</i>	<i>Number of Responses</i>
>10	12	10.90	12	5
5.0-9.99	8	7.27	2	1
1.0-4.99	45	40.90	11	2
0.5-0.99	13	11.81	3	0
0.1-0.49	25	22.72	6	0
<0.1	7	6.36	1	0

In order to conduct a feasibility study, additional information from treatment plants on head, flow variations, and electricity usage was needed from treatment plants. All the treatment plants with flows greater than 10 MGD flow were contacted because the hydroelectric generation would be greatest with these relatively high flow ranges. In addition, one quarter of the plants from each flow range category were contacted to equally represent each category. Table 4 shows that responses were received from 3 small treatment plants and 5 treatment plants with flows greater than 10 MGD. Information gathered from these communications is discussed in section 2.2.

## 2.2 Selection of Facility for Case Study Analysis

Of the plants that were contacted, responses were received from 8 treatment plants as shown in Table 4. From this list, a facility was chosen for an in-depth study based on the average flow, head values, and data availability. Table 5 summarizes the data that was received from the plants that were contacted.

*Table 5 - Facility Information*

<i>Facility</i>	<i>Location</i>	<i>Average Daily Flow (MGD)</i>	<i>Approximate Available Head (ft)</i>
Deer Island WWTP	Boston	365	9
Upper Blackstone WPAD	Millbury	32	5.4
Lowell Regional WW Utility	Lowell	25	10
Lynn Regional WF	Lynn	21	17
Haverhill WWTP	Haverhill	10	Not Available
Holyoke WWTP	Holyoke	8	4
Amherst WWTP	Amherst	4.2	Not Available
Ayer WWTP	Ayer	1.2	Not Available

The UBWPAD in Millbury, MA is located less than 7 miles from Worcester Polytechnic Institute in Worcester, MA, where the feasibility study was conducted. A visit to the facility was made due to its close proximity, and the visit allowed for easier visualization of the wastewater treatment processes and the discharge route of the water. It also allowed for in-person contact with Mark Johnson, the Plant Manager at UBWPAD.

Treating an average of 32 million gallons of wastewater per day, the UBWPAD was selected because it is the facility that services the city of Worcester, MA, which is the second largest city in the state and in New England. Boston, the largest city in Massachusetts and in New England, is serviced by the Massachusetts Water Resources Authority at Deer Island, where hydropower technology already exists. Chapter 3 provides the case study analysis for the UBWPAD.

### 3. CASE STUDY: UPPER BLACKSTONE WATER POLLUTION ABATEMENT DISTRICT

The case study analysis was conducted on the Upper Blackstone Water Pollution Abatement District (UBWPAD) in Millbury, MA. Information was gathered from the plant staff, and an estimate of the power potential was created. Then, a turbine was selected, a design was considered, and piping material was chosen.

#### 3.1 UBWPAD Overview

The UBWPAD serves a number of cities and towns in Massachusetts, including Auburn, Cherry Valley Sewer District, Holden, Millbury, Rutland, West Boylston, and Worcester. Portions of Oxford, Paxton, Shrewsbury, and Sutton are also served by this wastewater treatment facility (Upper Blackstone Water Pollution Abatement District, 2013). Some households in these towns may have septic tanks instead of being directly connected to the sewer system. Although not all of the households are directly connected to the sewer, the sewage water from septic tanks is also transported to the UBWPAD for treatment (Johnson, 2013).

The UBWPAD collects used water from residential homes, commercial buildings, industrial companies, and storm water. The wastewater is treated by various processes before it is discharged into the Blackstone River. First, the wastewater goes through preliminary treatment, which consists of bar screens and grit chambers, where large objects and grit are removed to reduce wear and damage to mechanical components in the treatment system. The wastewater then travels to primary treatment, where some suspended solids and organic material are removed by settling. The water then goes to biological nutrient removal, where fine solids, chemicals, and organic matter are removed via bio-reactors, which provide necessary oxygen to sustain living organisms such as bacteria and plankton that digest the remaining organic material. This process is also known as activated sludge. After this stage, the water flows to secondary clarifiers, where the cell biomass settles out of the water. After secondary treatment, the water travels to the chlorine contact chamber, where the water is treated with sodium hypochlorite to inactivate pathogens in the water. At the UBWPAD facility, this stage is performed seasonally because there is less recreational use of the receiving water body in the winter than in the summer. After the wastewater is disinfected, it is dechlorinated with sodium bisulfite. Finally, the wastewater flows through an effluent discharge out to the Blackstone River (Upper Blackstone Water Pollution Abatement District, 2013).

If a turbine system were to be implemented at this facility, it could be placed at the end of the disinfection process in the effluent channel. The effluent channel would be ideal location for a turbine because of the quality of the water. The suspended solids concentration in the influent of the UBWPAD is 140 mg/L, and the effluent suspended solid concentration is 2.7 mg/L (Upper Blackstone Water Pollution Abatement District, 2013). Suspended solids could create wear on the turbine blades, so placing the turbine in the effluent channel would reduce the possibility of

turbine damage.

Information on the UBWPAD facility was gathered to determine whether or not the integration of a hydroelectric turbine system was economically viable for this site. This information included the available head in varying flood conditions, dimensions of the chlorine contact chamber, weir height, effluent channel and culvert specifications, plant electricity costs, and flow data. The effluent flow data and the average electric costs per month for operations were directly obtained from the plant staff. The available head, dimensions of the chlorine contact chamber, weir height, and effluent channel and culvert specifications were determined using detailed drawings and the hydraulic profile provided by plant staff (Johnson, 2013). After this information was gathered, the potential power output was calculated. A site visit provided information about the space available to implement the turbine, how the treatment plant operates, and the design of the existing effluent channel.

### **3.2 Potential Power Output**

As shown in the EPA listing of Massachusetts treatment plants (Appendix B), the flow through the UBWPAD averages 32 million gallons per day. The average flow value was used in power calculations because it provides a long term assessment of power generation capabilities.

Dimensions of the chlorine contact chamber, weir, and the effluent channel were obtained from detailed drawings provided by the plant staff. These detailed drawings are provided as Supplementary Documents to this report. The chlorine contact chamber, where water is disinfected before its discharge, has dimensions of 90 feet by 50 feet. The weir is the wall located at the end of the tank where the water spills over into the effluent channel and out to the river, and its height is 9.9 feet. The effluent channel, where water flows out after treatment, is 50 feet long and 12 feet wide.

The hydraulic profile is a document providing elevation information with respect to the weir and the effluent discharge channel at varying flood conditions. The UBWPAD hydraulic profile is provided as a Supplementary Document to this report. The available head is measured as the elevation difference from the water height in the chlorine contact chamber (410.0 feet) to the water height at the end of the effluent discharge (404.4 feet). Using the hydraulic profile, normal river height, defined as the height of the river under no flood conditions, yields a total available head of 5.6 feet, and a 5-year flood yields a total head of 1.1 feet. However, the 25- and 50-year floods yields negative values for elevation because the water in the river rises higher than the height of the water in the chlorine contact tank. As a result under these two conditions, the river floods the chlorine contact chamber and the area surrounding the tank.

Based on head, flow, and constants pertaining to the water density, gravitational acceleration, and efficiency, the power that can be generated from a turbine at the UBWPAD was determined



using Equation 1.

$$P = \eta\rho_w gQH \quad (\text{Equation 1})$$

Where:

- $P$  is power (kW)
- $\eta$  is the efficiency of the turbine (unitless)
- $\rho_w$  is the density of the water ( $\text{kg/m}^3$ )
- $g$  is the acceleration due to gravity ( $\text{m/s}^2$ )
- $Q$  is the flow of water through the turbine ( $\text{m}^3/\text{s}$ )
- $H$  is the head (m).

For efficiency ( $\eta$ ), a value of 85% was assumed. This value is commonly used by engineering firms to determine the approximate power generation produced by the system (De Vooght, 2013). The efficiency is a factor of safety accounting for losses due to friction through the turbine and the piping system (De Vooght, 2013).

The next variable is the density of the water flowing through the turbine system ( $\rho_w$ ). The density of the water is approximately  $1000 \text{ kg/m}^3$ . As shown in Table 6, density changes by less than 1% with a 40-degree change in temperature. Therefore, density was used as a constant value in Equation 1.

*Table 6 - Change in Water Density with Respect to Temperature*

<i>Temperature (°C)</i>	<i>Density (<math>\text{kg/m}^3</math>)</i>	<i>% Change of Density</i>
0	999.8	0
10	999.7	0.01
20	998.2	0.16
30	995.7	0.41
40	992.2	0.76

The third variable is gravitational acceleration ( $g$ ), which is constant at  $9.81 \text{ m/s}^2$ . Next is the volumetric flow rate ( $Q$ ). The flow rate of wastewater through the UBWPAD changes throughout the day depending on local water usage. Daily influent flow data for 2012 was provided by the UBWPAD staff, and one day without rain and with minimal snow melt was chosen at random to best represent the average influent flow trends of the treatment plant. The peak flows happen between 1 PM and 4 PM, and the minimum flows happen between 3 AM and 7 AM (see Figure 8). The maximum values are correlated to when people are using the most

water throughout the day. These flow variations are important when conducting an in-depth feasibility study because the variations will affect the amount of potential energy the water contains. The UBWPAD designed the chlorine contact chamber to accommodate the peak flow, max daily flow, average flow, and the minimum flow. For this study, the average volumetric flow rate of 32 million gallons per day ( $1.40 \text{ m}^3/\text{s}$ ) at the UBWPAD was used.

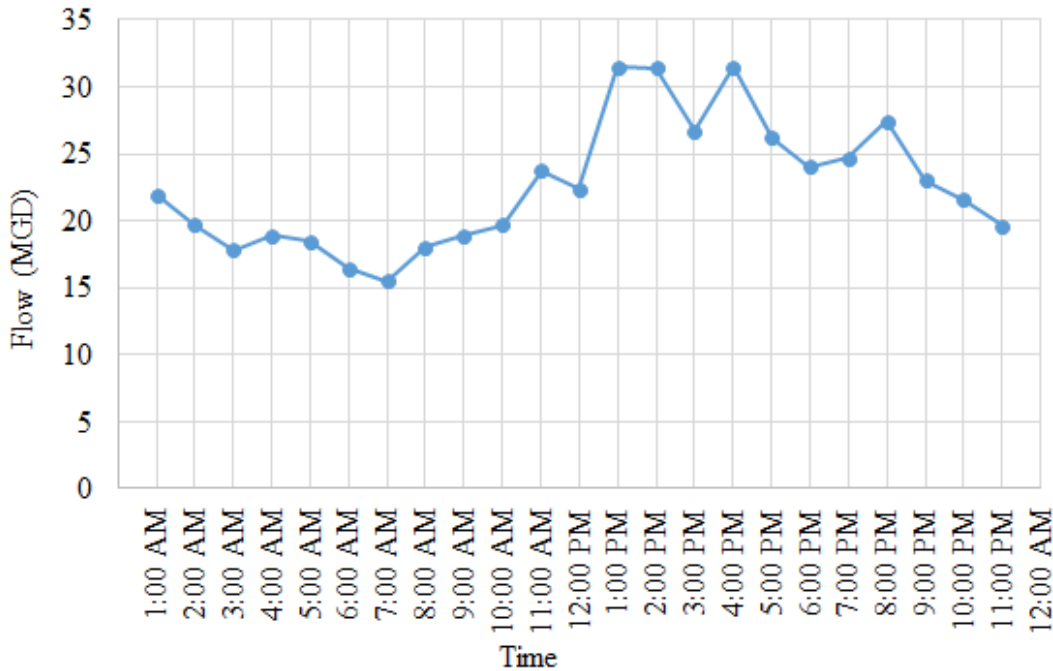

Figure 8 - Variations in Flow Rate through Sewer System at UBWPAD throughout 24-Hour Period (Adapted from UBWPAD Data Found in Appendix C)

Finally, the head ( $H$ ) at normal river height is 5.6 feet, or 1.7 meters. The preliminary calculations and design were based on the normal river height as this represents typical operating conditions. Under these conditions, the system has the maximum potential for energy production. Combining all of the variables and constants discussed above, a potential power output was calculated using Equation 1.

$$P = \eta \rho_w g Q H \quad (\text{Equation 1})$$

$$P = (0.85) \left( 1000 \frac{\text{kg}}{\text{m}^3} \right) \left( 9.81 \frac{\text{m}}{\text{s}^2} \right) \left( 1.40 \frac{\text{m}^3}{\text{s}} \right) (1.7 \text{ m})$$

$$P = 19,846 \text{ W}$$

$$P = 19.9 \text{ kW}$$

At normal river height, a turbine installed at the UBWPAD has the potential to produce up to

19.9 kW of electricity. The results for the remaining river heights are summarized in Table 7.

*Table 7 - Power Potential Based on Available Head at UBWPAD*

<i>Flood Case</i>	<i>Flood Case Height (ft)</i>	<i>Available Head (ft)</i>	<i>Available Head (m)</i>	<i>Power Potential (kW)</i>
Normal River Height	405.0	5.6	1.7	19.9
5-Year Flood	409.5	1.1	0.33	3.9
25-Year Flood	412.0	-1.4	-0.42	N/A
100-Year Flood	414.3	-3.7	-1.12	N/A

With the information above, and assuming normal river height and 85% efficiency, the potential power generation for the minimum, average, maximum, and peak hour flow was calculated. The range of flows will affect the power that the turbine will be able to produce. The results are shown in Table 8

*Table 8 - Power Potential for Varying Flow Rates for UBWPAD*

<i>Flow Condition</i>	<i>Flow Rate (MGD)</i>	<i>Flow Rate (m<sup>3</sup>/s)</i>	<i>Power Generation Potential (kW)</i>
<i>Minimum Flow</i>	25.6	1.12	15.9
<i>Average Flow</i>	32.0	1.40	19.9
<i>Maximum Flow</i>	80.0	3.51	49.8
<i>Peak Hour Flow</i>	120	5.26	74.6

The power generation potential contributes to the total annual revenue generated from the turbine system. Flows will vary with seasons and times of the day. These variations will need to be analyzed when performing a complete feasibility study. This feasibility study only accounts for average numbers in order to provide baseline information for the UBWPAD.

**3.3 Turbine Selection**

There are two main classes of turbines: impulse turbines and reaction turbines. Impulse turbines use the velocity of moving water to rotate the turbine blades and generate electricity, and they are typically used in high head and low flow applications. Pelton wheels and cross-flow turbines are considered impulse turbines. The pelton wheel typically has at least one free jet that

discharges water into an area which fills the buckets of the runner. The cross-flow turbine is shaped like a drum and uses a jet to discharge water against the runner. This turbine allows for the water to pass through the runner two different times, once when the water flows from the outside to the inside of the blade and the second time is when the water flows from the inside to the outside of the blades. Cross-flow turbines were developed to accommodate higher flows and lower heads than the pelton wheel (U.S. Department of Energy, 2014).

The other major class of turbines is reaction turbines, in which power is generated using the pressure of moving water. The runner is located in the water stream, which flows over the runner as opposed to striking each blade individually. These turbines are generally implemented in lower head and higher flow applications than impulse turbines. The francis, kinetic, and propeller turbines are all considered reaction turbines. The francis turbine has fixed buckets or runner vanes, and water is released above and around the runner, causing the buckets to fill and the runner to spin. Propeller turbines have a variety of types, such as Kaplan turbines and bulb turbines (micro turbines). Both of these turbines have a runner with three to six blades, and these adjustable blades maintain contact with the water at all times (U.S. Department of Energy, 2014). The orientation of these two types of turbines is different; Kaplan turbines are placed vertically in the flow of the water while bulb turbines, which are typically used for low flow applications, can be integrated directly into horizontal flows. Vertical orientation requires that the direction of the flow be changed from horizontal to vertical. Horizontal orientation allows for turbines to be directly integrated into pipes with horizontal flows (U.S. Department of Energy, 2014).

The head specifications for different impulse and reaction turbines are presented in Table 9. These specifications were used to determine what type of turbine would be best suited for the UBWPAD case study analysis. The information in Table 9 suggests that the cross flow and the bulb turbines would be suited based on the applicable head ranges.

*Table 9 - Turbine Operational Head Specifications*

<i>Class</i>	<i>Turbine Type</i>	<i>Head Range (m)</i>
Impulse	Pelton Wheel	200-1800
	Cross Flow	2.5-200
Reaction	Francis	40-600
	Kaplan	15-50
	Bulb	<30

The cross flow turbine is categorized as an impulse turbine, where the bulb turbine is categorized as a reaction turbine. Both of these turbines operate under different conditions. Impulse turbines

change the direction of the flow with a high velocity jet positioned at the bottom of the runner. The impulse from the water spins the runner by increasing the velocity of the water being discharged onto the runner. Reaction turbines use the pressure of the water to develop torque that rotates the runner. Because of the pressure, reaction turbines need to be completely submerged into the fluid. This allows for the turbine to be implemented into a pipe system, whereas the cross flow turbine would not be able to be placed in a closed pipe system. Therefore the reaction bulb turbine would be best suited for the UBWPAD case study analysis (Prakash, 2014).

Bulb turbines, also known as micro turbines, are generally used in low-head applications — less than 30 meters — and flow rates from 2 MGD to 80 MGD. If there are conditions that are over 30 meters or 80 MGD, these turbines can be put in parallel arrangements for higher flows, or in series for a greater effective head. The different types represent different turbine sizes, which are designed to operate in a wide range of flow and head conditions, allowing for high efficiency. The runner design of these turbines is an essential contribution to the high efficiency; the runner blades are designed to adjust the angle due to the flow variations, making the turbine and generator 94% efficient (Voith Siemens Hydro, 2008). These turbine-generator packages allow for low installation costs and simple maintenance procedures because the straight pipe for the water passage simplifies construction work. This design also reduces the concrete volume by mounting the generator on the turbine structure. Maintenance for the turbines (Appendix D) consists of replacing bearings and the mechanical seal every 5 years, and transmission belts and lubrication oil annually (Toshiba Corporation *et al.*, 2014).

Micro turbines have a presence in large wastewater treatment plants. The wastewater treatment facility in Point Loma, San Diego, CA uses the flow of water through the facility to create electricity to sell back to the San Diego Gas and Electric Company. The project totaled \$1.2 million, including turbine cost, piping cost, electrical cost, transmission lines, engineering time and other labor associated with the project. This was partially funded by the California Energy Commission and the State of California, totaling \$780,000. This treatment facility generates 1.35 megawatts of renewable energy using hydroelectric turbines (United States Environmental Protection Agency, 2013). This application is an example of a large treatment plant integrating hydroelectric turbine technologies into an already existing system.

A number of manufacturers that provide micro turbines were contacted, and their turbines were researched to determine the best fit for this project (Appendix D). These manufacturers include Energy Systems and Design, Power Pal, Canyon Hydro, Toshiba International, VLH Turbine, Voith Siemens, and HydroCoil. These manufacturers design and produce micro tubular turbines for different applications. The micro tubular turbine models from these manufacturers are listed with their specifications in Table 10. The turbines manufactured by Voith Siemens and Toshiba were applicable to case study at UBWPAD because this plant operates with a flow of 32 million gallons per day, which falls between the flow ranges of these two models.

*Table 10 - Micro Turbine Model Specifications (United States Environmental Protection Agency, 2013)*

<i>Manufacturer/ Model</i>	<i>Applicable Head (feet)</i>	<i>Applicable Flow (MGD)</i>	<i>Cost</i>	<i>Power Output (kW)</i>
Energy Systems and Design Model LH 1000	10	1.3	\$3,000	1
Power Pal Model MHG 1000LH	5	3.2	\$4,000	1
Canyon Hydros Kaplan Turbine	30 - 50	64.6 - 258.5	\$30,000 - \$500,000	unavailable
Toshiba International Horizontal Hydro-eKIDS	6.6 - 49.2	0.6 - 77.6	\$7,000 - \$30,000	5 - 250
VLH Turbine	4.2 - 10.5	0.2 - 0.5	\$575,000 - \$1,100,000	100 - 500
Voith Siemens	6 - 66	2.3 - 91.3	\$650,000 - \$800,000	unavailable
HydroCoil	10 - 60	0.8	unavailable	unavailable

Most manufacturers provided limited specifications that did not include the price for their turbines. Therefore, turbine manufacturers were contacted. Chirag Panchal, an engineer at Voith Siemens, provided a quote that was between \$650,000 and \$800,000 for a micro tubular turbine with installation fees included, but piping costs were not included (Panchal, 2013). The Environmental Protection Agency published a document referring to Toshiba as a turbine manufacturer that produces micro tubular turbine models similar to the models by Voith Siemens. The Toshiba models were quoted between \$7,000 and \$30,000 for turbine and installation fees (United States Environmental Protection Agency, 2013). Toshiba Hydro-eKIDS micro turbines come in three different sizes: S-Type, M-Type, and L-Type. Specifications for these turbine types are displayed in Table 11. Toshiba was contacted directly, but a quote was not received to determine the exact price for this micro turbine. Due to the dramatic price difference between the turbine models manufactured by Voith Siemens and Toshiba, the Toshiba turbine model was selected for the UBWPAD case study.

*Table 11 - Dimension Specifications of Toshiba Micro Turbines (Adapted From Toshiba Corporation et al., 2014)*

<i>Specification</i>	<i>L-type</i>	<i>M-type</i>	<i>S-type</i>
<i>Inlet Diameter (ft)</i>	4.43	1.97	0.99
<i>Outlet Diameter (ft)</i>	3.29	1.97	0.99
<i>Width (ft)</i>	5.25	3.64	1.97
<i>Length (ft)</i>	15.09	6.73	4.13
<i>Height (ft)</i>	8.20	5.57	3.28
<i>Weight (tons)</i>	7.5	3.1	1.0
<i>Discharge Range (MGD)</i>	22.82 - 79.89	2.28 - 31.95	2.28 - 6.85
<i>Head Range (ft)</i>	6.56 - 49.21	6.56 - 49.21	6.56 - 49.21
<i>Power Generation Range (kW)</i>	10 - 200	5 - 100	5 - 25

Toshiba International Horizontal Hydro-eKIDS turbines are propeller turbines that are best suited installation in pipes. This particular turbine has adjustable runner blades to adapt to the conditions in the effluent pipe, and it can be installed in parallel or in series to maximize the usage of the equipment. Figure 9 depicts a basic schematic of the Horizontal Hydro-eKIDS L-Type Turbine.

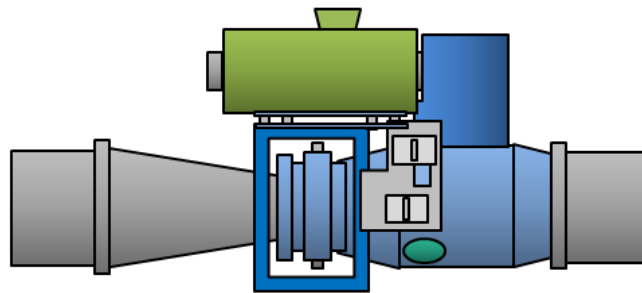

*Figure 9 - Horizontal Hydro-eKIDS L-Type Turbine (Adapted from United States Environmental Protection Agency, 2013)*

The dimension specifications vary among the different types of turbines (Appendix D), and different types of turbines are selected for projects based on the potential power, flow, and available head. Turbine types do not vary significantly across different manufacturers.

The L-Type turbine was selected for analysis because this size turbine accommodates the 32-MGD flow rate at the UBWPAD. The S-Type and the M-Type do not accommodate the flow range for the UBWPAD. The minimum head specification for the L-Type turbine exceeds the available head at UBWPAD by approximately one foot, which will likely have an effect on the turbine efficiency. This was not considered for this feasibility study. The L-Type turbine has an inlet diameter of 4.43 feet and outlet diameter of 3.29 feet. Because a quote was not provided by Toshiba, the highest price was used because the largest turbine was selected for this case study analysis (see Chapter 4).

### 3.4 Design Considerations

The pipe size that was chosen for this turbine was 4.0 feet in diameter. Although the turbine inlet diameter is 4.43 feet, a pipe with this diameter is not a standard size. This size pipe would need to be custom ordered to fit this application. To accommodate the size difference from the pipe to the turbine inlet, a change over fitting would need to be installed.

To ensure that the pipe containing the turbine is consistently full (promoting maximum efficiency), a stationary weir was designed to be implemented in the pre-existing effluent outfall in order to divert the water into the turbine effluent discharge pipe. The height of this wall was determined to be equal to the diameter of the turbine effluent discharge pipe, or 4.0 feet using the L-Type turbine. The height of the wall will contain the water in the outfall unless the flow is large enough to spill over the wall. In the case of an overflow, the water will flow over the weir and into the pre-existing effluent channel depicted in Figure 10. The complete solid model design and detailed drawings can be found in Appendix E.

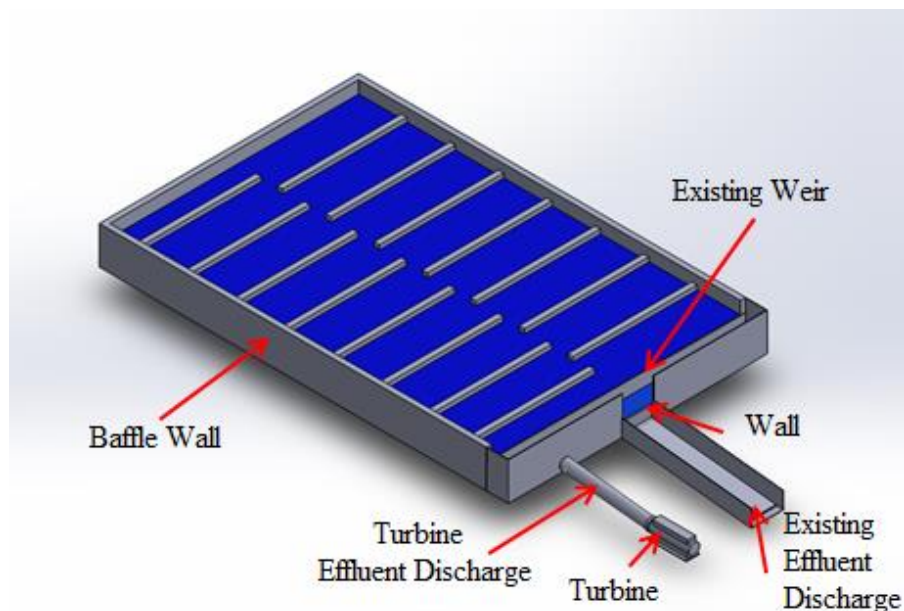

*Figure 10 - Model of Chlorine Contact Chamber at UBWPAD and Redesigned Effluent.*



Valves are to be installed at both ends of the channel, with the turbine located between these valves. The first valve at the higher end of the discharge pipe is a gate valve. This valve can be manually opened or closed by the plant operators in order to manage or stop the flow of water through the discharge pipe. The second valve at the lower end of the pipe is a check valve. This valve prevents any water from flowing into the pipe in the opposite direction of the water flowing out from the plant.

### 3.5 Piping Material Selection

Some materials that are commonly used in wastewater treatment systems are steel, lined ductile iron, and smoothed cement. Selecting the pipe material is an important factor for this project because the friction losses through a pipe may affect the power output of the turbine. The material of the pipe was chosen based on these criteria: the amount of friction losses that occur, the pricing of the materials, and the lifespan of the piping material.

The Darcy-Weisbach Equation (Equation 2) was used to determine the friction losses through the pipe.

$$h_f = f_D * \frac{L}{D} * \frac{V^2}{2g} \quad (\text{Equation 2})$$

Where:

- $h_f$  is the head loss due to friction (ft, m)
- $L$  is the length of the pipe (ft, m)
- $D$  is the diameter of the pipe (ft, m)
- $V$  is the average velocity of the fluid flow (ft/s, m/s)
- $g$  is the local acceleration due to gravity (ft/s<sup>2</sup>, m/s<sup>2</sup>)
- $f_D$  is the Darcy friction factor coefficient (unitless)

For this calculation, a length of 35 feet (10.67 m) was used because this is the length of pipe needed for the UBWPAD. The total length of the outfall is 50 feet, but the turbine itself is 15 feet long, so only 35 feet of pipe is necessary for the design. The diameter used in this calculation was 4.0 feet because this is the size pipe used for the case study analysis. The velocity was calculated using Equation 3.

$$V = \frac{Q}{A} \quad (\text{Equation 3})$$

Where:

- $V$  is the velocity (m/s)
- $Q$  is the volumetric flow rate (m<sup>3</sup>/s)

$A$  is the cross-sectional area of the pipe ( $m^2$ )

In this equation, the volumetric flow rate ( $Q$ ) is equal to 32 million gallons per day, which converts to  $1.40 m^3/s$ . The cross sectional area refers to that of the pipe, and it is dependent on the diameter of the pipe, which is 4.00 feet (1.22 m). The cross sectional area of this pipe is  $1.17 m^2$ . Therefore, the velocity of the fluid flow through the pipe is  $1.2 m/s$ .

The Darcy friction factor ( $f_D$ ) was determined from the Moody Diagram based on the Reynolds Number and the relative roughness. There are multiple steps to determining the Darcy friction factor. First, the Reynolds Number was calculated using Equation 4.

$$Re = \frac{\rho V d_h}{\mu} \quad (\text{Equation 4})$$

Where:

$Re$  is the Reynolds Number (unitless)

$\rho$  is the density of the water ( $kg/m^3$ ,  $lb_m/ft^3$ )

$V$  is the velocity (ft/s, m/s)

$d_h$  is the hydraulic diameter (ft, m)

$\mu$  is the dynamic viscosity ( $Ns/m^2$ ,  $lb_m/s \text{ ft}$ )

The density ( $\rho$ ) of the water was assumed to be  $1000 kg/m^3$ , under the same assumptions discussed in section 3.1. Velocity ( $V$ ) is consistent with the velocity used in Equation 2, which is  $1.2 m/s$ . The hydraulic diameter ( $d_h$ ) is equal to the diameter of the pipe, 1.22 meters. Finally, the dynamic viscosity ( $\mu$ ) of water at 20 degrees Celsius (the same temperature used for the density of water) is  $1.002 Ns/m^2$ . Substituting these values back into Equation 4, the Reynolds is calculated:

$$Re = \frac{\rho V d_h}{\mu} \quad (\text{Equation 4})$$

$$Re = \frac{(1000 \frac{kg}{m^3})(1.2 \frac{m}{s})(1.22 m)}{1.002 \frac{Ns}{m^2}}$$

$$Re = 1461$$

Flow is considered laminar, transitional (transient), or turbulent if the Reynolds numbers are less than 2,300, between 2,300 and 4,000, or greater than 4,000, respectively. This Reynolds Number suggests that the water flowing through the pipe is laminar because the value is less than 2,300.

After determining the Reynolds number, the next step in determining the Darcy Friction factor was to calculate the relative roughness. The relative roughness was calculated with Equation 5 (Houghtalen *et al.*, 2010).

$$r = \frac{k}{d} \quad \text{(Equation 5)}$$

Where:

- $r$  is the relative roughness (unitless)
- $k$  is the roughness of pipe surface (ft, m)
- $d$  is the diameter of the pipe (ft, m)

For commercial steel, the roughness of the pipe surface is  $1.5 \times 10^{-4}$  ft. For smoothed cement, the roughness is  $1 \times 10^{-3}$ . Therefore, the relative roughness values for steel and smoothed cement are  $3.8 \times 10^{-5}$  and  $2.5 \times 10^{-4}$ , respectively.

The final step in determining the Darcy Friction factor was to use the Moody Diagram in Figure 11. The Darcy Friction factor was found to be 0.044 for both commercial steel and smoothed cement.

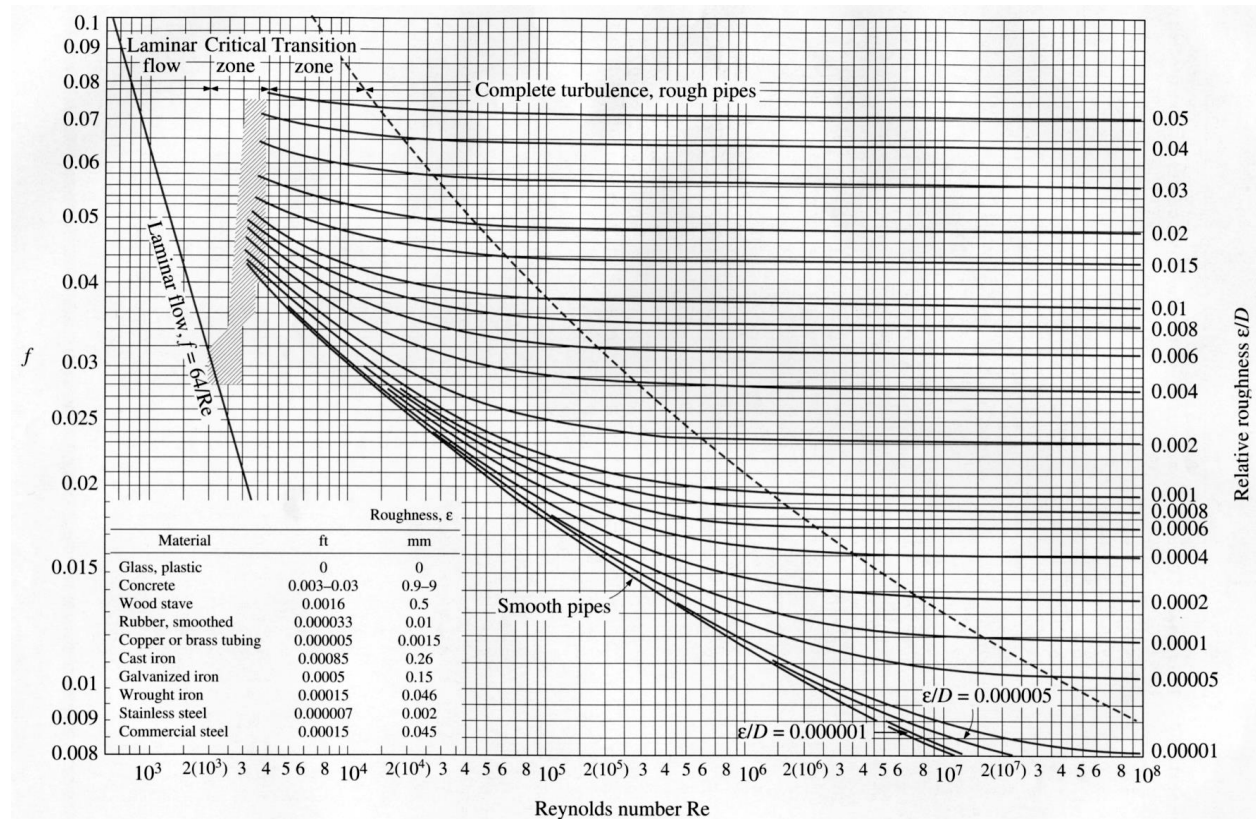

Figure 11 - The Moody Diagram (Unaltered from Diagramme, 2013)

Since the flow through the pipe is laminar ( $Re < 2,300$ ), a simpler method can be used to determine the frictional losses. With laminar flow, the friction factor can be calculated using Equation 6:

$$f_D = \frac{64}{Re} \quad (\text{Equation 6})$$

Since the Reynolds number is dependent on the flow and not on the type of piping material, it remains the same for all piping materials. Using Equation 6, the Darcy friction factor will be 0.044 for any piping material used under the specifications at UBWPAD.

The losses due to friction were determined using Darcy-Weisbach Equation (Equation 2).

$$h_f = f_D * \frac{L}{D} * \frac{V^2}{2g} \quad (\text{Equation 2})$$

$$h_f = (0.044) * \left( \frac{10.67 \text{ m}}{1.22 \text{ m}} \right) * \left( \frac{\left( 1.2 \frac{\text{m}}{\text{s}} \right)^2}{2 * 9.81 \frac{\text{m}}{\text{s}^2}} \right)$$

$$h_f = 0.028 \text{ m}$$

Table 12 represents the pipe materials with frictional head losses and price per foot for 4.0 foot diameter and 35 foot long pipes.

*Table 12 - Frictional Characteristics of Different Piping Materials*

<i>Surface</i>	<i>Roughness Coefficient (ft)</i>	<i>Relative Roughness</i>	<i>Re</i>	<i>Darcy Friction Factor</i>	<i>Head loss due to friction (m)</i>	<i>Price Per Foot</i>
<i>Commercial Steel</i>	$1.5 \times 10^{-4}$	$3.8 \times 10^{-5}$	1461	0.044	0.028	\$595
<i>Smoothed Cement</i>	$1 \times 10^{-3}$	$2.5 \times 10^{-4}$	1461	0.044	0.028	\$268

Commercial steel and smoothed cement both experience 0.028 meters, or 1.1 inches, of head loss due to the friction over a pipe length of 35 feet. Since friction losses are the same for all materials with laminar flow, the price per foot and lifespan are the criteria for the choice of piping material. According to Table 12, smoothed cement would be the best choice of piping material due to the lower price per foot. The general lifespan of commercial steel is between 50

and 70 years (Baird, 2011). The general lifespan of smoothed cement is greater, ranging between 70 and 100 years. Therefore, the selected pipe material for UBWPAD is smoothed cement. Smoothed cement also has a compressive strength ranging between 4,000 psi to 8,000 psi. The compressive strength is the capacity of the material to withstand loads that reduce the size of the material (American Concrete Pipe Association, 2014). A combination of cement and steel piping is used at Deer Island Wastewater Treatment Facility as the inlet and piping for the turbines. Where steel is used in this application, epoxy is applied to help resist the corrosion of the pipe (O'Brien, 2014).

### **3.6 Operational and Maintenance Considerations**

This system was designed to be installed in the effluent of a wastewater treatment system rather than the influent because of the quality of the water. The concentration of suspended solids in the influent of a wastewater treatment plant is much greater than the concentration of suspended solids in the effluent. Suspended solids could create wear on the turbine blades, so placing the turbine in the effluent channel will not wear the turbine blades down as quickly as if it were placed in the influent channel. This design consideration will help to save money on maintenance costs. This assumption can be made across the nation because influent and effluent characteristics show minimal variations regardless of the region (Davis, 2009).

Instead of incorporating the turbine into the pre-existing effluent channel, the separate discharge channel was designed to provide accessibility to the turbine and generator for maintenance. If the turbine is located in the existing effluent channel, maintenance issues could potentially arise. By installing a separate channel for the turbine, the flow is able to be controlled or stopped for maintenance. The maintenance of this system follows a schedule provided by the turbine supplier and may vary depending on the type and manufacturer.

Another reason for implementing this system into a separate channel was to control flooding. In this system, there are valves located at both ends of the channel, and the turbine is located between these valves. This setup allows for water to be diverted if necessary, such as in the case of flooding. The valve at the lower end of the discharge pipe would be a check valve. This valve would only allow for water to flow one way out of the pipe, and it would prevent water from flowing up the pipe during natural flooding conditions. The valve located at the higher end of the turbine effluent discharge would be a gate valve, which would allow the operator to manually close the valve to reduce or shut down the flow into the turbine effluent discharge pipe.

#### 4. ECONOMICS

The costs that are associated with implementing hydroelectric power recovery at a wastewater treatment facility consist of turbine cost, turbine foundation cost, piping system cost, and project contingency, which make up the system installation costs. These costs are offset by the benefit of electricity being sold back to the grid comparing the costs and the benefits allows for assessment of the feasibility of the project. There are also yearly operating and maintenance costs which were not considered for this case study analysis because more information would be necessary to create a specific maintenance schedule. General maintenance may consist of replacing belts, bearings, and runner blades.

##### 4.1 System Installation Costs at UBWPAD

The system installation costs are composed of the turbine system, turbine foundation, piping system, and contingency factor. The cost of the turbine system includes the turbine itself, electrical panels, transmission lines and engineering. The foundation for the turbine is a poured concrete slab. The dimensions of the concrete slab, which will determine the cost of the concrete and labor, are provided by the turbine manufacturer. The piping costs are determined based on the length and diameter of the pipe. Costs for the turbine system, concrete, and piping are inclusive of installation fees. After the costs for the turbine system, concrete slab, and piping system are determined, a contingency percentage is added as a safety factor for any blind costs that may occur during the project. A summary of system installation costs for the Upper Blackstone Water Pollution Abatement District is shown in Table 13, which shows installation costs of approximately \$49,500. Details on each of these costs are provided in the following sections.

*Table 13 - Estimated System Installation Costs for UBWPAD (Waier, 2011)*

<i>Component</i>	<i>Specification</i>	<i>Cost</i>
Turbine	15.09' x 5.25' x 8.20'	\$30,000
Concrete	15.1' x 5.3' x 1.0'	\$242
Piping	35' length; 4' Smoothed Concrete	\$9,380
Subtotal	-	\$39,622
Contingency	25%	\$9,906
<b>TOTAL</b>	-	<b>\$49,528</b>

#### 4.1.1 Turbine and Generator System

The turbine system chosen for this application is manufactured by Toshiba. Therefore, the price range used for the selected turbine was determined from the Renewable Energy Fact Sheet: Low Head Hydropower from Wastewater in August of 2013 by the United States Environmental Protection Agency, which shows Toshiba's turbine system costing from \$7,000 to \$30,000 (United States Environmental Protection Agency, 2013). The cost used in the feasibility analysis was based on the maximum cost of the turbine because the selected size of the turbine was the largest option available. The \$30,000 price covers the turbine itself, electrical panels, installation, and engineering fees.

#### 4.1.2 Piping

The piping cost is dependent on the selected material, length, and diameter. For UBWPAD, the selected material of the pipe is smoothed cement, with a length of 35 feet, and a diameter 4.00 feet. This material has a price of \$268 per foot, including material and labor costs (Waier, 2011).

Smoothed cement was selected as the piping material for this project because it costs less per foot. The material cost per length foot will increase with an increase in diameter. With a larger diameter inlet and outlet of the turbine, the choice of pipe material may vary depending on the price difference between materials. Depending on the effluent flow rate, the piping diameter will change to accommodate the hydraulics of the system. The inlet and outlet diameters of the turbines manufactured by Toshiba range from one foot to five feet. Pipes with diameter greater than five feet can be accommodated to these turbines using tapered fittings.

#### 4.1.3 Concrete

The cost for concrete is dependent on the dimensions of the required concrete slab, which is dependent on the size of the turbine and the location of the anchor bolts. For this case, the cost of the cement is a rough estimate due to certain constraints. In order to come up with a more accurate cost for the concrete slab, the manufacturer must supply system drawings and system specifications, which will give the location of the anchor bolts and the correct dimensions of the turbine footings. This information was not made available by the manufacturer, so the concrete slab cost shown in Table 13 is a rough estimate based on the turbine weight of 7 tons and the turbine dimensions of 15.09 feet long by 5.25 feet wide. A concrete slab with dimensions of 15.1' x 5.3' x 1.0' will accommodate the size and weight of the turbine (Toshiba Corporation *et al.*, 2014). Based on these dimensions, the total cost for concrete materials would be \$242 (Waier, 2011).

#### 4.1.4 Contingency

The total cost of this project includes a 25% contingency plan. This 25% is based on the average contingency percentage that contractors use when implementing a startup project. As a project is developed, the contingency will drop over time, but a higher contingency is initially used to

avoid overrun fees. This buffer compensates for unplanned costs that may arise throughout the design and construction of a project (Connecticut Department of Transportation, 2013).

## 4.2 Electricity Benefit

Once the Toshiba Hydro-eKIDS turbine goes online, power generated, by the turbine will offset electricity costs at the UBWPAD. The amount of money that is saved on electricity consumption depends on how much can be generated from the turbine, the percentage of the total energy consumption that hydroelectric power production would cover, and the price of electricity.

### 4.2.1 Consumption Costs to Facility

Electricity consumption costs per year will vary depending on the facility. Facilities use electricity to keep plant operations running continuously, as well as to power the offices and buildings in which employees work.

Mark Johnson, a plant staff member at the UBWPAD, provided the plant's electricity usage from January 2012 until December 2012. The electricity used in 2012 at the UBWPAD totaled 16,400,000 kWh. In the state of Massachusetts, the consumption cost per kWh of electricity is \$0.15, meaning that in 2012, the UBWPAD spent approximately \$2.5 million on electricity costs.

### 4.2.2 Production from Hydropower

Theoretically, the calculations made in section 3.2 state that a hydroelectric turbine at the UBWPAD would generate 19.9 kW at an average flow of 32 MGD, which is approximately 174,000 kWh of electricity per year.

$$19.9 \text{ kW} * 24 \frac{\text{hours}}{\text{day}} * 365 \frac{\text{days}}{\text{year}} = 174,324 \frac{\text{kWh}}{\text{year}}$$

Selling it back to the grid at \$0.10 per kWh, the UBWPAD could save approximately \$17,400 on electricity costs each year (Site Based Energy, 2013). Based on the 2012 electricity consumption, a hydroelectric turbine system has the potential to produce roughly 1.1% of the electricity needs at the UBWPAD.

## 4.3 Payback Period

One of the most important factors in determining the economic feasibility of a mechanical project is the length of the payback period, which is the period of time required for the amount of money saved to equal the amount of money spent on the project.

Staff members at multiple wastewater treatment facilities in Massachusetts were contacted in order to determine a reasonable payback period. Dan O'Brien, a plant manager at Deer Island in



Boston, MA, argues that a reasonable payback period should be between 0 and 10 years. In Haverhill, plant manager Fred Haffty requests a payback period that is a quarter of the length of the expected life of the project equipment, in order to “take the risk out of a premature failure of the equipment.”

An average expected useful life of 20 years was determined from the MWRA’s Expected Useful Life of Capital Projects mechanical equipment capital improvement (Massachusetts Water Resources Authority, 2014). Using this 20-year useful life, it was determined from Haffty’s request that a reasonable payback period would be 5 years, which is also between 0 and 10 years as O’Brien argued.

As for the UBWPAD, with theoretical yearly savings of approximately \$17,400, and a total system installation cost totaling approximately \$49,500, the payback period for this facility would be 2.84 years, deeming this project potentially feasible according to the payback period.

However, the turbine selected for this system operates with a head range between 2 meters and 15 meters. The available head at the UBWPAD is 1.7 meters, falling just short of the applicable range of the turbine. Therefore, UBWPAD would benefit from a detailed feasibility analysis to determine if there was a better design to allow for the turbine to operate efficiently at 1.7 meters.

#### **4.4 Permits, Regulations, and Incentives**

When designing a hydroelectric turbine project, permits and incentives can be applicable and are an important factor in determining the feasibility of a project. Different projects require permits and can be candidates for state wide incentive programs and funding to aid with the design and installation phase of projects.

One permit that would be required for this project is a Federal Energy Regulatory Commission, or FERC license. A project is subject to the FERC jurisdiction if (Federal Energy Regulatory Commission, 2013):

1. The project is located on navigable waters of the United States.
2. The project occupies public lands or reservations of the United States.
3. The project utilizes surplus water or waterpower from a federal dam.
4. The project is located on a body of water over which Congress has Commerce Clause jurisdiction, project construction occurred on or after August 26, 1935, and the project affects the interests of interstate or foreign commerce

This project would fall under item 4 where “the project affects the interests of interstate or foreign commerce” (Dean, 2014). This indicates that if the project will displace electricity from the regional grid or connect to the regional grid, then the project would be required to be licensed. In order to be licensed, a project manager can apply in one of two ways: the traditional

licensing process (TLP), or the alternate licensing process (ALP). The TLP requires that the applicant completes a document along with a three stage pre-filing process, 18 CFR 4.38. The stages for this process are as follows:

- First Stage
  - Applicant issues notice of intent, preliminary application document, request to use TLP, and newspaper notice;
  - Commission approves use of TLP;
  - Applicant conducts joint agency/public meeting and site visit;
  - Resource agencies and tribes provide written comments; and
  - Agencies, tribes, or applicant request dispute resolution on studies with the Commission.
- Second Stage
  - Applicant completes reasonable and necessary studies;
  - Applicant provides draft application and study results to resource agencies and tribes;
  - Resource agencies and tribes comment on draft application; and
  - Applicant conducts meeting if substantive disagreements exist.
- Third Stage
  - Applicant files final application with Commission and sends copies to agencies and tribes.

The ALP is designed to improve the communication between the Commission and the applicant. This process allows for the applicants to customize the pre-filing consultation process to each individual case. It also allows for the applicant to combine the environmental review and the pre-filing process into one process under the National Environmental Policy Act. This process also allows for the preparation of a preliminary environmental assessment by the applicant or an environmental impact statement by a contractor that is chosen by the Commission and is paid for by the applicant. The required documents for this process are located in 18 CFR 4.34 Order No. 596. Building permits may apply to this project but will be specific to the town and region the project is being constructed.

When designing and constructing a hydropower reclamation project, different incentives can be applied to the funding and cost of the project. Massachusetts offers different incentives for small hydropower projects because Massachusetts requires that a portion of electricity shall be generated from renewable energy sources. This project falls into the RPS Class I program, allowing the majority of the project to be funded by the state. One of the programs offering funding for projects that qualify from the RPS Class I criteria are from the Mass Clean Energy Center under the Commonwealth Hydropower Program. This project offers up to \$600,000 for the design and construction, and up to \$40,000 for the feasibility study (U.S. Department of Energy *et al.*, 2013).

## 5. EXTENDED ANALYSIS USING HYPOTHETICAL FLOW AND HEAD CASES

Different facilities have the potential to generate varying amounts of electricity based on the volumetric flow rate of water through the plant, as well as the available head from the hydraulics and structure of the plant. This chapter extends the case study analysis at UBWPAD to the other treatment facilities in Massachusetts using hypothetical cases of flow and head.

### 5.1 Hypothetical Flow and Head Cases

The average volumetric flow rates of the 110 wastewater treatment facilities in Massachusetts were provided by the EPA (U.S. Environmental Protection Agency-New England, 2011); however, the available head levels at these facilities were not provided. Therefore, the analysis performed in the UBWPAD case study was extended by the creation of hypothetical head and flow cases.

The ranges of the hypothetical head cases were based on the applicable ranges within which all three sizes of the selected Toshiba Hydro-eKIDS turbines operate. All three turbine sizes operate between 6.56 and 49.21 feet of head. For this analysis, the head range was rounded to 6 to 50 feet, with 2-foot increments from lowest to highest from 6 to 20 feet, then 10-foot increments from 20 to 50 feet. The ranges of hypothetical flow cases were based on the range of average flow rates for the 110 treatment facilities in Massachusetts. The average flow rate for these facilities ranges from 0.016 million gallons per day to 365 million gallons per day. However, Deer Island, which has the largest flow rate of these facilities (365 MGD), was not included in this analysis since hydropower already exists at that facility. Therefore, the flow range was between 0.016 million gallons per day to 45 million gallons per day. For this analysis, the flow range was rounded to 2 to 46 million gallons per day, with 2-MGD increments from lowest to highest. The minimum cutoff was 2 MGD because any flow rates lower than this would not be accommodated by the selected turbine. Any cases that do not fall within these ranges of head and flow may be deemed not feasible for the installation of this hydropower project using Toshiba Turbines.

### 5.2 Feasibility of Hypothetical Hydropower Scenarios

In order to determine the feasibility of installing hydroelectric power generation for the hypothetical cases of head and flow that were created, three steps were taken. First, potential power generation (in kWh) was calculated for all possibilities of flow and head combinations within these ranges. These values were calculated based using Equation 1 (see section 3.1). A table listing these values can be found in Appendix F. Second, the potential power generation values were translated into savings, using a retail price of \$0.10 per kWh sold to the grid. Yearly savings (rounded to the nearest dollar) for each combination of artificial head and flow cases are listed in Appendix F. Finally, the yearly savings were compared to the system installation cost of \$49,500, which was rounded up to \$50,000 for convenience. It is recognized that these costs

would vary based on site specific features. Payback periods were calculated for each of the cases. A table of the hypothetical cases and their payback periods can be found in Appendix F.

Cases that had a payback period of five years or fewer were deemed feasible, while cases with payback periods greater than five years were determined to be potentially feasible with some modification, or not feasible. One example of a modification that could be made to make the potential cases feasible includes creating pumped storage tanks to hold the effluent (see Section 1.2.3). This modification would require pumps to be used to transport the water into a holding tank at night during hours of lower electricity demand. The water would then be discharged to the turbine during the day when electricity demand is at its peak. However, the addition of pumps and a storage tank, along with other forms of modifications, would create additional costs and could potentially affect the payback period, which could in turn affect the feasibility of the project. Table 14 illustrates the feasibility of the different combinations of hypothetical flow and head cases, as well as which size of the Hydro-eKIDS turbine would be best suited for each case.

Table 14 - Feasibility Chart for Varying Hypothetical Flow and Head Cases

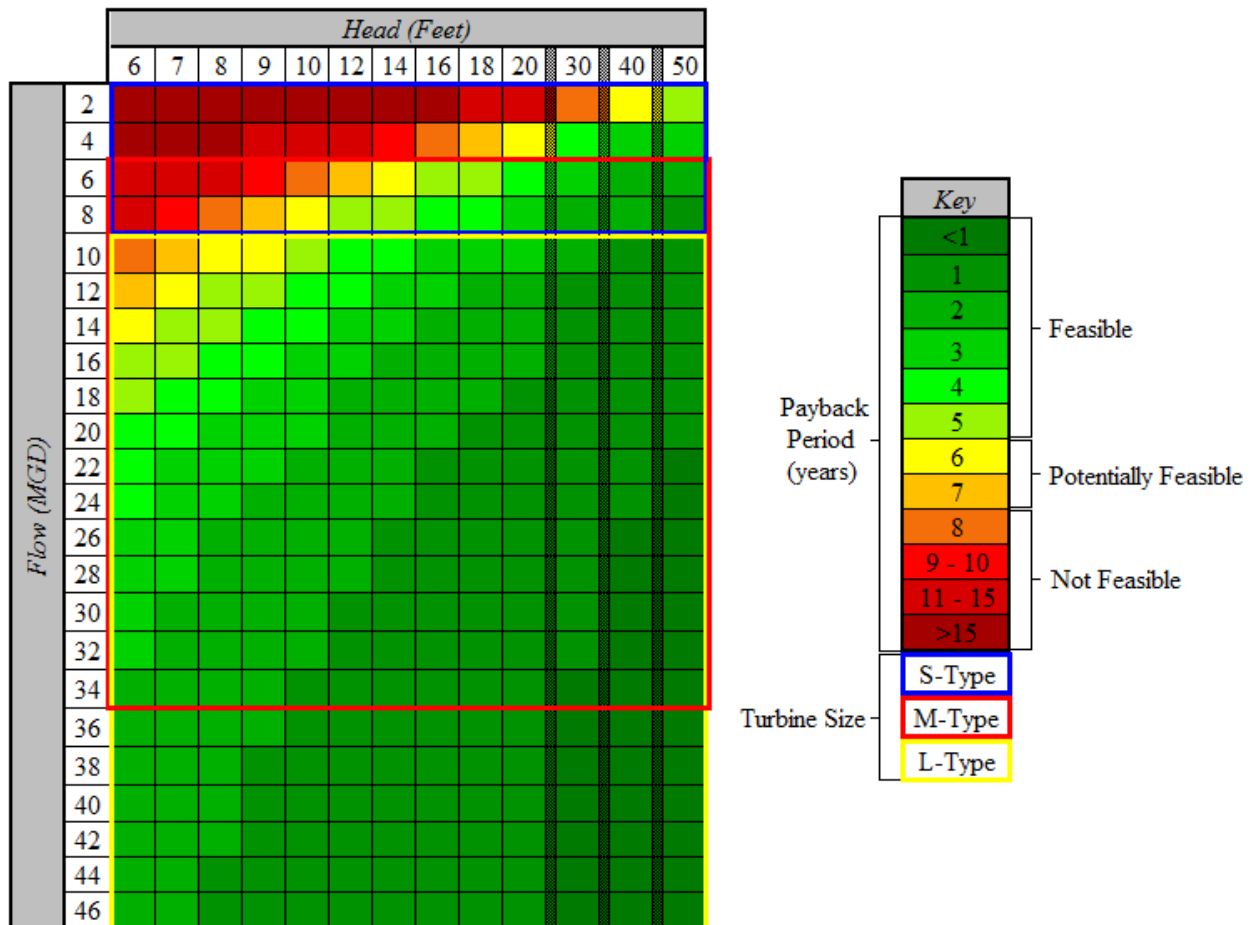

A total of 299 hypothetical cases were analyzed, with 86.3% of the cases being feasible, 4.3%

being potentially feasible with some modification, and 9.4% being not feasible. As displayed in the table, 100% of flow cases greater than or equal to 16 million gallons per day would be feasible for the implementation of this hydropower project, as long as the available head is within the range that the Hydro-eKIDS turbine accommodates. For cases with average flows less than 16 million gallons per day, 50 out of the 91 cases were feasible (54.9%), and 13 were potentially feasible with modification (14.3%). Less than a third (30.8%) of the cases with flows less than 16 million gallons per day were deemed not feasible.

### **5.3 Feasibility of Massachusetts Wastewater Treatment Facilities**

Using the chart generated from hypothetical flow and head combinations, Massachusetts wastewater treatment facilities have the ability to determine the feasibility of implementing this hydropower project by comparing real flow and head data from their facilities to the hypothetical flow and head cases.

In Massachusetts, there are nine wastewater treatment facilities with volumetric flow rates greater than 16 million gallons per day (not including Deer Island). If these nine plants each have head values in the range of 6 to 50 feet, then this hydropower project would likely be feasible for these facilities.

Out of the 110 wastewater facilities in Massachusetts, 76 of them (69.1%) accommodate flow rates that are less than 2 million gallons per day. Since the Hydro-eKIDS turbine (at any size) does not operate with flows this low, these 76 facilities were deemed not feasible.

The remaining 34 wastewater treatment plants in Massachusetts have average volumetric flow rates between 2 and 16 million gallons per day. Depending on the available head at these facilities, any of them could be deemed as either feasible or not feasible. Those with an available head between 40 and 50 feet will likely be feasible according to Table 14. However, smaller head values will decrease the likelihood of feasibility. These 34 facilities would benefit from conducting an in-depth feasibility study, much like that performed on UBWPAD in Chapters 3 and 4. This in-depth study would provide detailed information about the available head and flows, which would then assist in determining the power output and the payback period for this hydropower project.

## 6. CONCLUSIONS AND RECOMMENDATIONS

The purpose of this feasibility study was to determine if hydropower energy recovery was feasible in wastewater treatment facilities. A case study was examined for a 32-MGD treatment plant, and then the analysis was extended for hypothetical scenarios of flow and head conditions. This study examined different factors in conducting a feasibility study such as the cost of construction of a hydroelectric turbine system, laws and regulations, and the payback period.

### 6.1 Feasibility at UBWPAD

The UBWPAD is a 32-MGD facility with a chlorine contact chamber as the final process before discharge. The change in elevation from the top of the weir to the river is 5.5 feet. Using a horizontal turbine, 19.9 kW would be generated, which would be about 174,000 kWh per year. The total cost for the turbine system installation would be approximately \$49,500, but the electricity generated on site would save the facility approximately \$17,400 each year, resulting in a payback period of 2.84 years. However, the selected Toshiba turbine is rated for a minimum head of 2 meters. This facility would benefit from a more detailed analysis to determine whether or not the Toshiba turbine would function in the facility. Because this turbine's minimum head requirement just over the head available at UBWPAD, with some redesign of the effluent, there is a possibility that this project could be implemented at this facility.

### 6.2 Feasibility at Other Wastewater Treatment Plants

This feasibility study provided insight into implementing hydroelectric turbines into wastewater treatment plants to reclaim energy. This project evaluated flow ranges between 2 and 46 million gallons per day. These values cover a range of flows recorded at wastewater treatment plants across Massachusetts, excluding Deer Island and excluding plants with flows less than 2 million gallons per day. The head values of Massachusetts plants were not readily available; therefore, the head values used in this case were based off of the selected turbine specifications, between 6 feet and 50 feet. From calculations performed for 299 possible head and flow combinations, this project was able to determine potential cases that would benefit from hydropower energy recovery systems, with 86.3% of the hypothetical cases deemed feasible.

Using the table produced from the hypothetical head and flow case analysis (Table 14), Massachusetts treatment plant staff can determine an estimate of the payback period of this hydropower project at their facilities by matching the available head and average volumetric flow rate at their wastewater facility to those on this table. If the project is determined as feasible or potentially feasible, that facility may then perform a more in-depth analysis similar to that performed on UBWPAD in Chapter 3 and Chapter 4.

## **6.3 Recommendations**

Though the implementation of a hydroelectric turbine system may not be feasible for the effluent pipe of every wastewater treatment facility, there are other options for implementing renewable energy. A hydroelectric turbine alone may not be economically feasible, but the addition of other energy reclamation systems could make the investment more worthwhile. The wastewater treatment facility at Deer Island uses a combination of renewable energy technologies, and these technologies have the potential to be applied at other wastewater treatment facilities.

### 6.3.1 Deer Island Energy Reclamation

Deer Island Wastewater Treatment Plant serves the Boston area and treats approximately 365 million gallons of wastewater per day. Deer Island currently uses hydroelectric turbine technologies in the effluent stream. This technology was implemented in the early 1980s and has been generating 6,000,000 kWh annually, saving the facility about \$600,000 per year in electricity costs. Deer Island also uses other forms of renewable energy such as methane from the anaerobic digesters, wind energy, solar energy, and steam turbine generation. With all of these renewable energy technologies, along with electrical upgrades, Deer Island produces 26% of their total electricity on site (Massachusetts Water Resources Authority, 2013).

### 6.3.2 Potential for Energy Reclamation at UBWPAD

The Upper Blackstone Water Pollution Abatement District also has the potential for energy reclamation on site, other than hydropower. Solar power is in the process of being implemented to produce up to 337 kW of electricity on site (Upper Blackstone Water Pollution Abatement District, 2012). During a site visit, plant manager Mark Johnson also suggested that steam generation (STG) could be a potential source of energy production for UBWPAD. This technology could be implemented with the on-site incinerator. The incinerator is used to burn sludge after the sludge-handling process. This sludge is transported to the UBWPAD facility from across Massachusetts to be incinerated. Figure 12 shows where there is potential for other renewable technologies at UBWPAD.



*Figure 12 - Potential Energy Reclamation Systems at UBWPAD*



## BIBLIOGRAPHY

- AltaGas, Ltd. (2014). “Run-of-River Hydroelectric.” *AltaGas, Ltd.* Calgary, Alberta, Canada. Retrieved from <<http://www.altagas.ca/sites/default/files/Run-of-river.Info%20Sheet.v1.pdf>>.
- American Concrete Pipe Association. (2014). “Made of Concrete.” *American Concrete Pipe Association*. Irving, TX. Retrieved from <<http://www.concrete-pipe.org/pages/why.html>>.
- Baird. (2011). “The Epidemic of Corrosion, Part 1: Examining Pipe Life.” *American Water Works Association*. Denver, CO. Retrieved from <[http://www.agingwaterinfrastructure.org/SiteResource/Site\\_109155/Customize/Image/file/Alternative%20Materials%20and%20Project%20Delivery%20Methods/AWWA%20Dec%202011%20The%20Epidemic%20of%20Corrosion%20Part%201%20Examining%20Pipe%20Life.pdf](http://www.agingwaterinfrastructure.org/SiteResource/Site_109155/Customize/Image/file/Alternative%20Materials%20and%20Project%20Delivery%20Methods/AWWA%20Dec%202011%20The%20Epidemic%20of%20Corrosion%20Part%201%20Examining%20Pipe%20Life.pdf)>.
- Brockhouse; Wadsworth. (2010, December). “Vital Steps: A cooperative feasibility study guide.” *U.S. Department of Agriculture*. Washington, D.C. Retrieved from <<http://www.rurdev.usda.gov/rbs/pub/sr58.pdf>>.
- Canyon Hydro. (2013). “Micro-Hydro Systems.” *Canyon Hydro*. Retrieved from <<http://www.canyonhydro.com/micro/index.html>>.
- Combs. (2008, April). “Hydropower.” *Window on State Government – Texas Comptroller of Public Accounts*. Austin, Texas. Retrieved from <<http://www.window.state.tx.us/specialrpt/energy/renewable/hydro.php#4>>.
- Connecticut Department of Transportation. (2013). “2013 Cost Estimating Guidelines.” *Connecticut Department of Transportation*. Connecticut. Retrieved from <[http://www.ct.gov/dot/lib/dot/documents/aec/final\\_2013\\_guideline.pdf](http://www.ct.gov/dot/lib/dot/documents/aec/final_2013_guideline.pdf)>.
- Consumers Energy; DTE Energy. (2006, December). “Ludington Pumped Storage Plant.” *Consumers Energy; DTE Energy*. Ludington, MI. Retrieved from <<http://www.consumersenergy.com/uploadedfiles/ceweb/shared/ludingtonpumpedstorage.pdf>>.
- De Vooght. (2013, September 12). *Coast Mountain Hydro*. Email interview.
- Dean. (2014, February 6). *Massachusetts Clean Energy Center*. Email interview.

- Diagramme. (2013, November 21). "Moody Diagram." *Diagramme: Diagram Resources and Information*. Retrieved from <<http://diagramme.info/wp-content/uploads/moody-diagram-712.jpg>>.
- Energy Realities. (2013). "Years of Fossil Fuels Remaining" [Infographic]. *Energy Realities*. National Geographic Maps. Retrieved from <<http://www.energyrealities.org/chapter/energys-future/item/years-of-fossil-fuels-remaining/erp6D28994FAAECC86A>>.
- Energy Systems & Design. (2011). "LH1000 Low Head Stream Engine." *Energy Systems & Design*. Retrieved from <<http://www.microhydropower.com/our-products/low-head-stream-engine/>>.
- Federal Energy Regulatory Commission. (2013, September 30). "Licensing Processes." *Federal Energy Regulatory Commission*. Washington, D.C. Retrieved from <<https://www.ferc.gov/industries/hydropower/gen-info/licensing/licen-pro.asp>>.
- Federal Energy Regulatory Commission. (2014, February). "Pumped Storage Projects." *Federal Energy Regulatory Commission*. Washington, D.C. Retrieved from <<http://www.ferc.gov/industries/hydropower/gen-info/licensing/pump-storage.asp>>.
- Freris; Infield. (2008). *Renewable Energy in Power Systems*. West Sussex, United Kingdom. John Wiley & Sons, Ltd.
- Houghtalen; Akan; Hwang. (2010). *Fundamentals of Hydraulic Engineering Systems*. Upper Saddle River, NJ. Pearson Higher Education.
- HydroCoil Power, Inc. (2014). "HydroCoil ® Turbine for Micro Hydro Electric Power Generation." *HydroCoil Power, Inc*. Retrieved from <<http://www.hydrocoilpower.com/3technology.html>>.
- Johnson. (2013, September 9). *Upper Blackstone Pollution Abatement District*. Personal Interview.
- Massachusetts Water Resources Authority. (2014). "Appendix 10: Expected Useful Life of Capital Projects." *Massachusetts Water Resources Authority*. Boston, MA. Retrieved from <<http://www.mwra.com/finance/cip/fy14final/appendix10.pdf>>.
- Massachusetts Water Resources Authority. (2013, July). "Renewable and Sustainable Energy Initiatives at Deer Island." *Massachusetts Water Resources Authority*. Boston, MA. Retrieved from <<http://www.mwra.state.ma.us/03sewer/html/renewableenergydi.htm>>.

- O'Brien. (2013, September 25). *Massachusetts Water Resources Authority*. Email interview.
- O'Donnell. (1876). *The City of Holyoke, Its Water Power and Its Industries, Holyoke, Massachusetts, U.S.A., 1876*. Springfield, MA. Clark W. Bryan & Co. Retrieved from [http://www.holyokemass.com/hwp\\_1876/tex2.html](http://www.holyokemass.com/hwp_1876/tex2.html).
- Panchal. (2013, November 9). *Voith Siemens*. Email Interview.
- PowerPal. (2014). "PowerPal Low Head." *PowerPal*. Retrieved from <http://www.powerpal.com/lowhead.html>.
- Prakash. (2014). "Hydraulics and Hydraulic Modeling." *Jawaharlal Nehru National College of Engineering*. Shimoga, Karnataka, India . Retrieved from [http://elearning.vtu.ac.in/P6/enotes/CV44/Reac\\_Tur-MNSP.pdf](http://elearning.vtu.ac.in/P6/enotes/CV44/Reac_Tur-MNSP.pdf).
- Site Based Energy. (2014). "Hydroelectric Generation at Wastewater Treatment Plants." *Site Based Energy*. Retrieved from <http://www.sitebasedenergy.com/company/partnerships/hydrogen>.
- Solar Energy Industries Association. (2014). "Net Metering." *Solar Energy Industries Association*. Washington, D.C. Retrieved from <http://www.seia.org/policy/distributed-solar/net-metering>.
- Toshiba Corporation; Toshiba Engineering Corporation. (2014). "Hydro-eKIDS: Micro Hydro Power Generating Equipment." *Toshiba Corporation; Toshiba Engineering Corporation*. Tokyo, Japan. Retrieved from [http://www.tic.toshiba.com.au/product\\_brochures\\_and\\_reference\\_lists/ekids.pdf](http://www.tic.toshiba.com.au/product_brochures_and_reference_lists/ekids.pdf).
- U.S. Army Corps of Engineers. (2014). "Building Strong at Bonneville Lock and Dam." *U.S. Army Corps of Engineers*. Portland District, Portland, OR. Retrieved from <http://www.nwp.usace.army.mil/Locations/ColumbiaRiver/Bonneville.aspx>.
- U.S. Department of Energy. (2011, September). "History of Hydropower." *U.S. Department of Energy*. Washington, D.C. Retrieved from [http://www1.eere.energy.gov/water/hydro\\_history.html](http://www1.eere.energy.gov/water/hydro_history.html).
- U.S. Department of Energy. (2011, September). "History of Wind Energy." *U.S. Department of Energy*. Washington, D.C. Retrieved from [http://www1.eere.energy.gov/wind/wind\\_history.html](http://www1.eere.energy.gov/wind/wind_history.html).

- U.S. Department of Energy. (2014). "Types of Hydropower Turbines." *U.S. Department of Energy – Office of Energy Efficiency & Renewable Energy*. Washington, D.C. Retrieved from <<http://energy.gov/eere/water/types-hydropower-turbines>>.
- U.S. Department of Energy; Interstate Renewable Energy Council; North Carolina Solar Center. (2013, March 19). "Commonwealth Hydropower Program." Database of State Incentives for Renewables & Efficiency. *U.S. Department of Energy; Interstate Renewable Energy Council; North Carolina Solar Center*. Boston, MA. Retrieved from <[http://www.dsireusa.org/incentives/incentive.cfm?Incentive\\_Code=MA90F&re=1&ee=1](http://www.dsireusa.org/incentives/incentive.cfm?Incentive_Code=MA90F&re=1&ee=1)>.
- U.S. Department of Energy; Interstate Renewable Energy Council; North Carolina Solar Center. (2013). "Net Metering." Database of State Incentives for Renewables & Efficiency. *U.S. Department of Energy; Interstate Renewable Energy Council; North Carolina Solar Center*. North Carolina State University. Raleigh, NC. Retrieved from <[http://www.dsireusa.org/incentives/incentive.cfm?Incentive\\_Code=MA01R](http://www.dsireusa.org/incentives/incentive.cfm?Incentive_Code=MA01R)>.
- U.S. Energy Information Administration. (2013). "AEO2014 Early Release Overview." *U.S. Department of Energy*. Washington D.C. Retrieved from <[http://www.eia.gov/forecasts/aeo/er/early\\_elecgen.cfm](http://www.eia.gov/forecasts/aeo/er/early_elecgen.cfm)>.
- U.S. Energy Information Administration. (2012, September). "Annual Energy Review 2011." *U.S. Department of Energy – Office of Energy Statistics*. Washington, D.C. Retrieved from <<http://www.eia.gov/totalenergy/data/annual/pdf/aer.pdf>>.
- U.S. Energy Information Administration. (2011). "Annual Energy Review 2011: Renewable Energy as Share of Total Primary Energy Consumption, 2011." *U.S. Department of Energy*. Washington, D.C. Retrieved from <<http://www.eia.gov/totalenergy/data/annual/?src=Consumption-f6#consumption>>.
- U.S. Energy Information Administration. (2011). "Primary Energy Consumption by Source and Sector, 2011." *U.S. Department of Energy*. Washington, D.C. Retrieved from <<http://www.eia.gov/totalenergy/data/annual/?src=Consumption-f6#consumption>>.
- U.S. Environmental Protection Agency–New England. (2011, September). "Municipally Owned Wastewater Treatment Facilities In New England." *U.S. Environmental Protection Agency–New England*. Boston, MA.

- Union of Concerned Scientists. (2002, October). "The Hidden Cost of Fossil Fuels." *Union of Concerned Scientists*. Cambridge, MA. Retrieved from [http://www.ucsusa.org/clean\\_energy/our-energy-choices/coal-and-other-fossil-fuels/the-hidden-cost-of-fossil.html](http://www.ucsusa.org/clean_energy/our-energy-choices/coal-and-other-fossil-fuels/the-hidden-cost-of-fossil.html).
- United States Environmental Protection Agency. (2013, August). "Renewable Energy Fact Sheet: Low-Head Hydropower from Wastewater." *United States Environmental Protection Agency*. Washington, D.C. Retrieved from <http://water.epa.gov/scitech/wastetech/upload/Low-Head-Hydropower-from-Wastewater.pdf>.
- Upper Blackstone Water Pollution Abatement District. (2012). "Annual Report: Fiscal Year 2012." *Upper Blackstone Water Pollution Abatement District*. Millbury, MA. Retrieved from <http://www.ubwpad.org/news/Final%20signed%202012%20Report.pdf>.
- Upper Blackstone Water Pollution Abatement District. (2013). "Upper Blackstone Water Pollution Abatement District." *Upper Blackstone Water Pollution Abatement District*. Millbury, MA. Retrieved from <http://www.ubwpad.org/index.html>.
- Voith Siemens Hydro. (2008, April). "Micro tubular turbines." *Voith Siemens Hydro*. Heidenheim, Germany. Retrieved from [http://www.matec.com.ph/documents/Micro\\_Tubular\\_Turbines.pdf](http://www.matec.com.ph/documents/Micro_Tubular_Turbines.pdf).
- Waier. (2011). *Building Construction Cost Data 2011*. R.S. Means Co., Inc.

## Appendix A: Deer Island Electricity Usage

Given:

Total MWRA yearly electricity consumption: 168,500,000 kWh

Percentage of total electricity consumption used by Deer Island: 70%

Deer Island yearly hydropower generation: 6,000,000 kWh

Deer Island yearly electricity consumption:

$$P_{Deer\ Island} = Total\ MWRA\ electricity\ consumption * \% Deer\ Island\ electricity\ consumption$$

$$P_{Deer\ Island} = 168,500,000\ kWh * 70\%$$

$$P_{Deer\ Island} = 117,950,000\ kWh$$

Deer Island hydropower contribution to total MWRA consumption:

$$\% P_{hydro,MWRA} = \frac{Deer\ Island\ hydropower\ generation}{MWRA\ electricity\ consumption} * 100\%$$

$$\% P_{hydro,MWRA} = \frac{6,000,000\ kWh}{168,500,000\ kWh} * 100\%$$

$$\% P_{hydro,MWRA} = 3.6\%$$

Deer Island hydropower contribution to total Deer Island consumption:

$$\% P_{hydro,DeerIsland} = \frac{Deer\ Island\ hydropower\ generation}{Deer\ Island\ electricity\ consumption} * 100\%$$

$$\% P_{hydro,DeerIsland} = \frac{6,000,000\ kWh}{117,950,000\ kWh} * 100\%$$

$$\% P_{hydro,DeerIsland} = 5.1\%$$

Appendix B: Massachusetts Municipal Wastewater Treatment Plants



**MASSACHUSETTS MUNICIPAL WASTEWATER TREATMENT PLANTS**

NPDES Permit #	Facility Name/ address	Primary Contact/ Email Address	Treatment Process Sludge Disposal	Design/ Permitted/avg daily Flow (MGD) CSO	Receiving Water Basin	Comments/ Potential Future Upgrades
MA0100315	Adams WWTP 273 Columbia Street Adams, MA 01220 (413) 743-8370	Joseph Fijal, Supt jfijal@town.adams.ma.us	AS, Cl, DChlor Nitr, DNitr, Prem, AdvTr TR, INC	5.1 4.6 Nov- May 3.5 Jun- Oct 2	Hoosic River	Sludge to Synergro - Waterbury, CT; 7 certified operators on staff; no plans for an upgrade
			Approved Pretreatment			
MA0101745	Amesbury WWTP 19 Merrimac St Amesbury, MA 01913 (978) 388-1912	Ed Crovetti fieldg@ames.ma.gov	AS  TR, Compost Approved Pretreatment	2.4 1.9 1.6	Merrimack River	3 certified operators on staff; had an upgrade in 2009, flow increased from 1.9 to 2.4, all new equipment, 5 kW generator, odor control unit
MA0100218	Amherst WWTP 586 South Pleasant St. (mail) Amherst, MA 01002 100 Mullins Way (plant) Hadley, MA 01035 (413) 259-3055	Jim Laford lafordj@amherstma.gov	AS  TR, INC	7.1  4.2	Connecticut River	6 certified operators on staff; no plans for major upgrade; Umass campus is using reuse water, doing a study right now to do more
MA0100005	Athol WWTP 584 Main Street Room 24 Athol, MA 01331 (978) 249-7600	Kirt Reilly atholwwtp@verizon.net	AS, EA  TR, INC	1.75 1.75 0.818	Millers River	3 certified operators on staff; had a big upgrade in 2007; no planned future upgrades
MA0100595	Attleboro WWTP 27 Pond Street (plant) 77 Park Street (mail) Attleboro, MA 02703 (508) 223-2222 x1820	Paul Kennedy waterpollutionsuperintendent@cityofattleboro.us	AS, AdvTr PRem, Nitr, SFilt DChlor,  LF	8.6 4.0	Ten Mile River	7 certified operators on staff; sludge disposed in on-site landfill; upgrading to Dnitr, to be completed by August 31, 2011;

				Approved		
				Pretreatm ent		
MA0100013	Ayer WWTP Brook Street Ayer, MA 01432 (978) 772-8243	John Loomer sewer@ayer.ma.us	AS, UV AdvTr, PRem	1.79 1.2	Nashua River	Sludge hauled to Fitchburg for incineration; 4 certified operators on staff; no plans for an upgrade
			TR, INC Approved Pretreatm ent			
MA0102571	Barnstable WWTP WPCD - DPW 617 Pierces Way Hyannis, MA 02601 (508) 790-6335	Peter Doyle peter.doyle@town.barnsta ble.ma.us	AS, AdvTr Nitr, DNitr	4.2 2.0	GW discharge	8 certified operators on staff; no plans for an upgrade
			TR, INC			
MA0103152	Barre WWTP 411 Wheelwright Road  Barre, MA 01005 (978) 355-5020	Thomas R. George Chief Operator  tgeorge@townofbarre.com	AS, EA, OD, UV  TR, LF	0.30 0.3 0.18	Ware River	3 certified operators on staff but united water gives assistance when needed; no plans for an upgrade
MA0102148	Belchertown WWTP P.O. Box 306 (mail) 175 George Hannum Rd (pl) Belchertown, MA 01007 (413) 323-0449	Rollin DeWilt rdewitt@belchertown.org	SBR, AdvTr Nitr, Prem, UV  TR	1.0 1.0 0.316	Lampson Brook Connecticut River	4 certified operators on staff; no plans for an upgrade in the near future
MA0101711	Billerica WWTP 70 Letchworth Avenue  N. Billerica, MA 01862 (978) 671-0956	Lorane Sander lsander@town.billerica.ma.us	AS, DChlor AdvTr, Nitr PRem  TR	5.52 5.4 4.4	Concord River	15 certified operators on staff; had an upgrade in 2010, comage for phosphorus and aluminum
			Approved Pretreatm ent			

MA0100641	Bridgewater WWTP 100 Morris Avenue Bridgewater, MA 02324  (508) 697-0937 (508) 697-0910	Jonas Kazlauskas jkazlauskas@bridgewater ma.org	RBC, AdvTr Nitr, DChlor Compost	1.44  0.977	Town River Madfield River Taunton River	6 certified operators on staff; currently waiting for permits from EPA to make changes
MA0101010	Brockton WWTP 303 Oak Hill Way Brockton, MA 02301 (508) 580-7885	Robert Bacher, proj manager robert.bacher@veoliawater .na.com	AS, UV, Prem, AdvTr Nitr, SFilt INC, LF  Approved Pretreatm ent	18 18 17.2	Salisbury Plain River	18 certified operators on staff; has been doing 5 years of upgrades; plant operates well
MA0103101	Charlemon WWTP 20 Factory Rd P.O. Box 137 Charlemon, MA 01339  (413) 339-5767	Dawn Peters chsd@crocker.com	SFilt UV  TR, INC	0.05  .02 - .025	Deerfield River	2 certified operators on staff; last major upgrade was in 1998; put in a solar system in 2004; no plans for an upgrade
MA0102598	Charles River PCD 66 Village Street Medway, MA 02053 (508) 533-6762	Chari Cousens ccousens.crpcd@verizon.n et	AS, PT AdvTr, Sfilt, Prem, Cl, Nitr, DChlor cloth filtration TR, INC  Approved Pretreatm ent	5.7 5.7 4.5	Charles River	Sludge hauled to an incinerator by Sinagro; 6 certified operators on staff; currently doing a capital improvement plans
MA0101141	Charlton WWTP 37 Main Street (mail) 7 Worcester Rd (plant)  Charlton, MA 01507 (508) 248-4699	Sandra Dam, Supt Jody St. George, Ch Op water.sewer@townofcharlton. net	RBC, UV AdvTr, Nitr PRem  TR, INC	0.45	Cady Brook Quinebaug  River	Sludge hauled to upper Blackstone plant for incineration
MA0100021	Chatham WPCF 221 Crowell Rd Chatham, MA 02633 59 Sam Ryders Rd West Chatham, MA 02669	Michael B. Keller kellerm@wseinc.com	AS, EA AdvTr, Nitr, DNitr  TR, LF	0.25 0.15 0.11	GW discharge	3 certified operators on staff and 1 pending operator; currently going through an upgrade, flow will

(508) 945-5153

be upgraded to 1.0 MGD, also all processes are going to be upgraded

MA0101508	Chicopee WWTP 80 Medina Street Chicopee, MA 01013 (413) 594-3585	Thomas Shea tshea@chicopeema.gov	PT, AS POXF, CI  TR Approved Pretreatm ent	15.5 25 8  CSO facility	Connecticut River	Installed 15MG CSO by-pass facility w/CI & DChlo to deal with 32 CSOs in system; permitted for 25MGD to secondary treatment plus an additional 10MGD to CSO, \$1 million a month on CSO project; small pump station upgrades
MA0100404	Clinton (MWRA) WWTP 677 High Street Clinton, MA 01510 (978) 365-7024	John Riccio jriccio@mwra.state.ma.us	TFilt, AdvTr PRem, Nitr, AS, DChlor  TR, LF  Approved Pretreatm ent	3.0  2.6	South Branch of Nashua River	7 certified operators on staff; 1 new generator so now plant can run on 100% backup power; has had some plant upgrades, bubble diffuser in aerators, 2 submersive pumps into influent and intermediate net wells (can pump 3.5 million gal), 3 on influent and 3 for effluent, upgrade digesters, designing for new valves and mixing system
MA0100285	Cohasset WWTP 43 Rear Elm Street (plant) P.O. Box 253 (mail) Cohasset, MA 02025 (781) 383-1519	Joseph Hughes Proj Mng joseph.hughes@unitedwater.com Steven Cushing, sup steven.cushing@united water.com	AS, UV Mfilt, SBR Nitr, DNitr TR, INC, LF	0.4 0.3 0.22	Cohasset Harbor	Sludge hauled to Brockton and incinerated; 2 certified operators on staff and 1 part time; operates as part of united water; no plans for an upgrade
MA0100668	Concord WWTF 509 Bedford Street Concord, MA 01742	Mike Thompson Chief Operator mthompson@woodwardcu	TFilt, UV AdvTr, PRem	1.2 1.2 1.1	Concord River	Sludge hauled via Up Blackstone and inc; comage

	(978) 371-7174 (978) 371-6310 (fax)	rran.com	TR, INC			process technology for phosphorus removal; had an upgrade 2007; no plans for an upgrade
MA0101605	Dartmouth WPCF 759 Russells Mills Road  Dartmouth, MA 02748 (508) 999-0740x214	Carlos M. Cardoso ccardoso@town.dartmouth.ma.us	AS, UV  COMP	4.2  2.5	Buzzards Bay	11 certified operators on staff; currently doing a condition survey report; hired engineers for a comprehensive facility study; going to do a 3 stage plant upgrade
MA0103284	Deer Island (MWRA) WWTP 190 Tafts Avenue Winthrop, MA 02152 (617) 660-7601 (617) 660-7870	Dan O'Brien, Director & chief operator dan.obrien@mwra.state.ma.us David Duest, Mgr dave.duest@mwra.state.ma.us	AS, POxF  CI, PT, Dchlor Pelletization TR, LAPP  Approved Pretreatment	361  1270 max  365  CSO facility	MA Bay	Sludge converted to fertilizer pellet; 47 treatment ops staff and 20 process control support staff; 5 permitted CSOs in system; undergoing long term CSO plan
MA0101095	Douglas WWTP Charles Street P.O. Box 624 East Douglas, MA 01516 (508) 476-2400	Robert Sullivan rsullivan@douglasma.org	SBR  TR, INC	0.60  0.2	Mumford River Upper Blackstone River	4 certified operators on staff; no plans for an upgrade
MA0101478	Easthampton WWTP 10 Gosselin Drive Easthampton, MA 01027 (413) 529-1426	Carl Williams ewwtp@hotmail.com	AS, DChlor  TR, INC  Approved Pretreatment	3.8  1.75	Manhan River Connecticut River	POTW has 2 separate outfalls; Senegro hauls sludge to incinerator; 7 certified operators on staff; small upgrades to the plant; 10 stations by the end of 2011 will be portable generator accessible
MA0101303	Edgartown WWTP West Tisbury Road P.O. Box 1068 Edgartown, MA 02539 (508) 627-5482	Joe Alasso jalosso@comcast.net	AS, EA, OD AdvTr, Nitr DNitr, UV	0.75  0.2	GW discharge	5 certified operators on staff; currently looking at TOC upgrade

			TR, COMP			
MA0101516	Erving POTW #1 16 Public Works Boulevard Erving, MA 01344 (413) 659-3354	Arthur Pace potwerving@crocker.com	AS, UV DChlor	1.02	Millers River	Sludge hauled to Fitchburg, 100% organic sludge; 3 certified operators; upgrade complete in 2009
			TR, INC	0.18		
			Approved Pretreatm ent			
MA0101052	Erving Center WWTP 97 East Main Street Erving, MA 01344 (413) 422-2700 x299 (413) 422-2720	Peter Coleman, gen op pcoleman@erseco.com pcoleman@ervingpapermill .com	AS, EA, AL	3.15	Millers River	Sludge is hauled by Northeast Organics, sludge is composted to fiber clay and then is put in steep slopes; 7 certified operators on staff; does small upgrades
			TR, COMP	1.86		
			Approved Pretreatm ent			
MA0100765	Fairhaven WPCF 5 Arsene Street Fairhaven, MA 02719 (508) 979-4031	Linda L. Schick fairhavenwpcf@comcast.n et	AS, UV	5.0	Acushnet River	12 certified operators on staff; currently working on a sludge digester
			TR, INC	3.0		
MA0100382	Fall River Regional WWF 1979 Bay Street Fall River, MA 02724 (508) 672-4530	Marc Laferriere marc.laferriere@violawater na.com	AS, POx  DChlor	30.9	Mt. Hope Bay	19 CSOs within system; about 60% of staff is certified; pump stations are being upgraded to include SCADA; Contract Ops
			TR, INC, LF	23-24 CSO facility		
			Approved Pretreatm ent			
GW discharge permit 3-168	Falmouth WWTP (154 Blacksmithshop Road) 416 Giford St (mail) Falmouth, MA 02540 (508) 540-9437	Charles Pires, ch op cpires@falmouthmass.us	SBR, DNitr UV	1.20 0.81	GW Discharge	Sludge is hauled to Cranston, RI POTW for incineration; 6 certified operators on staff
			TR, INC	0.4		
MA0100986	Fitchburg East WWTP 718 Main Street (office)  Lanadies Lane (plant) Fitchburg, MA 01420 (978) 353-2304	Joseph Schneider jschneider@fitchburgma.gov	AS, AdvTr Nitr, PRem Cl, DChlor INC	12.4	Nashua River	22 CSOs within system; planning CSO improvements; 11 certified operators on staff; just started a chemical enhancement upgrade, construction will start at the end of
			Approved Pretreatm ent	7.7 CSO facility		

2011/ beginning of  
2012

MA0100994	Gardner WPCF 52 Plant Road Templeton, MA 01438 (508) 632-4137	John Cormier john.cormier@earthtech.com	AS, TFilt, Nitr, PRem DChlo, AdvTr TR, LF, COMP Approved Pretreatment	5.0  4.0	Otter River	Jan 2006 did a pilot with polyaluminum hydroxychlorides for a possible removal upgrade for phosphorus and copper removal
MA0100102	Gilbertville WPC (Hardwick WPC) P.O. Box 147 Old Mill Rd Gilbertville, MA 01031 (413) 477-6959	Joseph Farrell gilbertvillewpcf@netzero.net	AS, EA  TR, INC	0.2 0.243 0.23	Ware River	2 certified operators on staff; main pump station is going through an upgrade, new generator at the station; plant is old and aging and needs an upgrade in the future
MA0102430	Gilbertville- Wheelwright WPCF Pase St. P.O. Box 147  Gilbertville, MA 01031 (413) 477-6959	Joseph Farrell gilbertvillewpcf@netzero.net	SBR  TR, INC	0.043  0.016	Ware River	2 certified operators on staff; had a complete plant upgrade in 2009 to a SBR facility; Hardwick employs; possibly pump station upgrade in the future
MA0100625	Gloucester WPCF 50 Essex Avenue Gloucester, MA 01930  (978) 281-3741		PT  TR, Compost Approved Pretreatment	7.24  CSO facility	Atlantic Ocean Mass Bay	
MA0101311	Grafton WWTP 9 Depot Street South Grafton, MA 01560 (508) 839-8526	Chuck Bohaboy	AS  TR, INC	2.4  1.8	Blackstone River	5 certified operators on staff; no plans for an upgrade
MA0101524	Great Barrington WWTP 100 Bentley Road Great Barrington, MA 01230 (413) 528-0650	Timothy Drumm tdrumm@townofgb.org	AS, DChlor Cl  TR, INC	3.65  1.0	Housatonic River+F261	4 certified operators on staff; by 2017 the plant will be upgraded, will include Nitrogen and

			Approved Pretreatm ent			phosphate removal
M0100447	Greater Lawrence Sanitary District 240 Charles Street North Andover, MA 01845 (978) 685-1612	Richard S. Hogan Executive Director rhogan@glsd.org	AS CI, DChlor  TR Approved Pretreatm ent	52.0 52.0 30 CSO facility	Merrimack River	Sludge heat dried Class A biosolids; wet weather expansion to allow treatment plant to accept up to 135MGD; 5 CSOs within system, currently have projects working on CSO control; 18 certified operators on staff;
MA0101214	Greenfield WPCP 384 Deerfield Street Greenfield, MA 01301 (413) 772-1539	Cliff Bassett, Supt	TFilt, DChlor  TR, INC	3.5  3.187	Deerfield River	Sludge hauled to Fitchburg for incineration; 6 certified operators on staff; had a major upgrade in 1999, no plans for a major upgrade in future; looking into alternative sludge disposal application methods
MA0100099	Hadley WWTP 230 South Middle Street  Hadley, MA 01035 (413) 585-0460	Dennis Pipeczynski sewer@hadleyma.org	EA  TR	0.54  0.4	Connecticut River+F282	3 certified operators on staff; in future may possibly do some upgrades to a couple of pump stations
MA0101290	Hatfield WWTP 260 Main Street Hatfield, MA 01038 (413) 247-9844	Brian McGraph brianm@townofhatfield.org	RBC  TR, INC	0.5 0.38 0.18	Connecticut River	Liquid sludge is hauled to Fitchburg for incineration; 1 certified operator on staff; sewers are being extended; no plans for a future upgrade
MA0101621	Haverhill WWTP	Fred Haffty	AS	18.1	Merrimack	11 certified



	40 South Porter Street Haverhill, MA 01835 (978) 374-2382	fhaffty@haverhillwater.com	TR, LF Approved Pretreatm ent	10.0 CSO facility	River	operators on staff; no plans for an upgrade
MA0101630	Holyoke WWTP One Berkshire Street Holyoke, MA 01040 (413) 534-2222	Mike Burke	AS, POx TR, LF Approved Pretreatm ent	17.5 8.0 CSO facility	Connecticut River	13 remaining CSOs in the collection system; 7 certified operators on staff; has under gone several upgrades recently including new pumps, CSO facility, bar racks, odor control, SCADA at pump stations, and a full upgrade on one of the pump stations
MA0100510	Hoosac WQD 667 Simonds Road Williamstown, MA 01267 (413) 458-8423	Bradley Furlon hw.qd@verizon.net	AS, PRem Cl, DChlo COMP Approved Pretreatm ent	6.50 3.5	Hoosic River	6 certified operators on staff; just had an upgrade; with new phosphorous limits will need to upgrade again, but does not have funs right not to do so
MA0102202	Hopedale WWTF 154 Mendon St (plant) P.O. Box 7 (mail) Hopedale, MA 01747 (508) 634-2210	Marcel Tremblay hopedalesewer@yahoo.co m	AS, PT, ST, UV PRem, Nitr TR	0.588 0.38	Mill River	Upgrades - Grit washer, collection system I&I removal, RBCs for enhanced ammonia nitrogen removal (or other method), flow pacing of chem feed and ras rate; 3 backup ops unlicensed
MA0101788	Hudson WWTF One Municipal Drive Hudson, MA 01749 (978) 562-9333 (978) 568-9675	Anthony Marques tmarques@townofhutson.o rg mlconcheri@comcast.net	TFilt, AS, AdvTr Nitr, DNitr PRem, DChlor	3.05 3.0 2	Assabet River	4 certified operators on staff; just finished a \$161.5 million upgrade

			TR, COMP, LF			
MA0101231	Hull WWTP 1111 Nantasket Avenue  Hull, MA 02045 (781) 925-1207	Edward E Petrilak epetrilak@town.hull.ma.us	AS, Dchlor  TR, INC	3.07 3.07  1.6-1.8	Atlantic Ocean	2 grade 6 operators and a bunch of grade 3 certified operators on staff; just installed a Dchlor system; had a \$1/4 million SCADA upgrade a few years ago; some work is currently being done on the collection system
MA0101265	Huntington WWTP Route 112 PO Box 301 Huntington, MA 01050  (413) 667-3356	James Gobeille jgobe11@verizon.net	AS, EA, OD, DChlor  TR, INC	0.20 0.07	Westfield River	Sludge trucked to Westfield POTW for incineration; 3 certified operators on staff; no plans for an upgrade
MA0100609	Ipswich WWTP 20 Fowlers Lane PO Box 151 Ipswich, MA 01938 (978) 356-6642	Patrick Brennan, Sup	AS, EA, UV  TR, COMP	1.8  1.0-1.1	Greenwood Creek Ipswich River	5 certified operators on staff; no plans for an upgrade
MA0100153	Lee WWTP 379 Pleasant St Lee, MA 01238 (413) 243-5525	Alan Zerbato azerbato@town.lee.ma.us	SBR  TR, INC	1.25 0.7	Housatonic River	3 certified operators on staff; built a brand new \$20 million SBR facility; in the future they may replace generators at pump stations, currently a contractor is evaluating the pump stations generators
MA0101796	Leicester WWTP 124 Pine Street P.O. Box 86 Leicester, MA 01524	Roger Hammond roger@lwsd.net	AS, EA, AdvTr Nitr, PRem,	0.37 0.37 0.24	Rawson Brook French River	Sludge hauled to Connecticut or Woonsocket for incineration; 3

	(508) 892-8484		SFilt TR, INC			certified operators on staff; looking at process changes, aluminum problem; currently looking at increasing the amount of flow; it is an old plant and is looking to upgrade in the future, 1st upgrade would be to the headworks system, possibly in Fiscal Yr 2013 or 2014
MA0100935	Lenox Center WWTP 239 Crystal St Lenox, MA 01242 (413) 637-5547	Jeffrey White lenoxwwtp@townoflenox.com	AS Cl, PRem TR, INC	1.8 1.19 0.68 CSO facility	Housatonic River	1 CSO in system; 2 certified operators on staff; no plans for an upgrade
MA0100617	City of Leominster WPCF 436 Mechanic Street Leominster, MA 01453  (978) 537-5720	Robert Chalifaux robert.chalifaux@veoliawaterma.com	AS, AdvTr PRem, Nitr DChlor TR, INC  Approved Pretreatment	9.3  5.29	North Branch Nashua River	8 certified operators on staff; by the end of the year beginning of next year will be able to have the entire plant operate on backup power; currently going through an upgrade that includes getting a new generator at the plant
MA0100633	Lowell Regional WW Utility 451 First Street Blvd Rt 110 Lowell, MA 01850 (978) 970-4248	Mark A. Young myoung@lowellma.gov	PT, AS Cl, DChlor TR, LF INC  Approved Pretreatment	32 32 25 CSO facility	Merrimack River	8 CSOs remain; 12 certified operators on staff; there is a plant upgrade going on right now; new sludge disposal contract in October

MA0100552	Lynn Regional WF 2 Circle Avenue Lynn, MA 01905 (781) 592-7048	Alfred Waitt alfred.waitt@veoliawaterna.com Bob Teiner	POxF  INC Approved Pretreatment	25.8 25.8 20-22 CSOs	Lynn Harbor	Sludge is incinerated on-site; currently is installing a new wind turbine; Contract Ops
MA0100871	Manchester By the Sea WWTP 12 Church Street Manchester By Sea, MA 01944 (978) 526-4612	John Sibbalds sibbaldsj@manchester.ma.us	AS  TR, INC	1.2 0.67 0.469	Manchester Harbor	Sludge hauled to Upper Back Stone POTW for incineration; 4 full time certified operators on staff; last upgrade completed in 1998; no plans for future upgrade, but may at some point in the future will need to Dchlor
MA0101702	Mansfield WWTP 6 Park Row(mail) Mansfield, MA 02048 88 Hill St Norton, MA 02766 (508) 285-5746	Ken Hackett, Sup wtcf.mansfield@verizon.net	AS, Sfilt AdvTr PRem, DChlor TR  Approved Pretreatment	3.14 2.065	Three Mile River	Synergro hauls liquid sludge away; 8 certified operators on staff; currently on preliminary stage for an upgrade, waiting for permit first; talking about forming a district with Norton and Foxboro
MA0100030	Marion WWTP Marion DPW 50 Benson Brook PO Box 1058 Marion, MA 02738	Frank Cooper, Sup fcooper@marionma.gov	SBR, AL UV  On-site storage	0.588 0.588	Aucoot Cove Buzzards Bay	Sludge is pumped out to lagoon on-site; has 20 acres of 3 lagoons; had a major upgrade to

(508) 748-3540

an SBR facility in 2005; CDM contract to relevant I&I; will be room in the future for growth of loading after I&I is taken care of; no plans right now for an upgrade

MA0100498	Marlborough East WWTP 860 Boston Post Road East Marlborough, MA 01752  (508) 624-6920	Scott Rossi  srossi@marlborough-ma.gov	AS, AdvTr PRem, Nitr DChlor  Compost  TR, LF	5.5  2.8 - 3.0	Hop Brook  Sudbury River	5 certified operators on staff; currently is at 30% design for major upgrade
MA0100480	Marlborough West WWTP 303 Boundary Street Marlborough, MA 01752  (508) 624-6919	Harry Butland, Chief Op  hbutland@marlborough-ma.gov	AS, AdvTr PRem, Nitr, UV  COMP  Approved Pretreatment	2.89  2.5	Assabet River	4 certified operators on staff; is currently going through an upgrade, UV improving phosphorous; waiting for permit to see if they can increase flow
MA0101737	Marshfield WWTF P.O. Box 268 Brant Rock, MA 02020  200 Joseph Dry Beeck Way Marshfield, MA 02050 (781) 834-5521	Kevin E. Silvia, Chief Op mfldwwtf@theworld.com	AS, EA UV  TR, INC	2.1  1.4	MA Bay	5 certified operators on staff; currently going through an aeration upgrade; in the future will do an effluent pump and screening upgrade, has hired an engineer and are in the designing phase
MA0101001	Maynard WWTP 18 Pine Hill Road Maynard, MA 01754 (978) 897-1020	David Simmons dasimrun@yahoo.com	RBC, AdvTr, PRem, DChlor	1.45  1.0	Assabet River	Liquid sludge is hauled to Millbury or Greater Lawrence; 5

			TR, INC			certified operators on staff; just went through generator upgrade; comag phosphorous removal started in March 2011. 60 day phos avg 0.0959
MA0100978	Medfield WWTP 99 Old Bridge Street Medfield, MA 02052 (508) 359-4533 (508) 359-6432 (fax)	Peter Iofolla	AS, EA, PT, SFilt PRem, AdTr, UV  TR, INC	1.52  1.32	Charles River	upgrades were finished in 2003; primary tank, aeration tank, diffused air, sec clar, new sfil and UV, new pump for PRem, looking to hire 1 or 2 additional operators
MA0101150	Merrimac WWTP 50 Federal Way Merrimac, MA 01860 (978) 346-9988	Barry Theriault btmwwtf@comcast.net	AS, EA, OD  TR, Compost	0.45  0.25-0.35	Merrimack River	4 certified operators on staff
MA0101591	Middleborough WWTP  Joe Ciaglo Lane Middleborough, MA 02346 (508) 946-2485	Todd Goldman, Sup	PT, AS, SFilt PRem, Nitr, Cl AdvTr, DChlo TR, LF  Approved Pretreatm ent	2.16  2.16 1.2-1.4	Nemasket River	5 certified operators on staff and 1 in training; possible future plant upgrade
MA0100579	Milford WWTP off Route 140 (Hopedale) P.O. Box 644 Milford, MA 01757 (508) 478-0059	John Mainini milfordwastewater@milfordma.com	RBC, AdvTr, TFilt, SFilt, UV, PRem, Nitr  TR, LF	4.3  3.5	Charles River	Sludge is hauled off site; 11 certified operators on staff; no plans for an upgrade at this time
MA0100188	Monroe WWTP Ecology Dr Monroe, MA 01350 (413) 424-8237	Norman Goodermote	RBC, UV  TR, LF	0.018 0.0085	Deerfield River	Seeking grant money to upgrade entire plant
MA0100137	Montague WPCF 34 Greenfield Road Montague, MA 01351-9522 (413) 773-8865	Robert J. Trombley wpcfsupt@montague-ma.gov	AS, Cl ST  TR, INC	1.83 1.83 1.0 CSO facility	Connecticut River	Currently sludge is thickened and hauled to Franklin County; in the future big be using a new dewatering

			Approved Pretreatm ent			system, a sludge cake ferrier rotary press; 2 CSOs in system, just finishing a CSO project; 5 certified operators on staff
MA0100781	New Bedford WWTP 1000 S. Rodney French Blvd New Bedford, MA (508) 991-6164	John P. Caron john.caron@veoliawaterna.co m	AS,Cl, DChlor  TR, INC  Approved Pretreatm ent	75.0 30  24	Outer New Bedford Harbor Buzzards Bay	Sludge hauled to Woonsocket, RI for incineration; 14 certified operators on staff, back up operators from other plants under Veolia Water; waiting for new EPA limits to see if effluent limit is changed Contract Ops
MA0101427	Newburyport WWTP 157 Water Street Newburyport, MA 01950  (978) 465-4422	Joseph Dugan, Ch Op jdugan@cityofnewburyport. com	AS Cl, Dchlo  TR, COMP Approved Pretreatm ent	3.4  2.34	Estuary to Merrimack River	Sludge hauled to Ipswich for a resource; 8 certified operators on staff; currently going through phase 1 of a \$29 million upgrade, will have full backup generator capability, SCADA upgrade for the plant, liquid sodium hypochlorite is used for Cl and metabisulfite for DChlor
MA0101036	North Attleborough WPCF Cedar Rd (plant) 49 Whiting St (mailing)  North Attleboro, MA 02760 (508) 695-7872	John K. Horton  jhorton@north- attleboro.ma.us	AS, AdvTr Nitr, PRem SFilt, PT Cl, DChlo  TR  Approved Pretreatm ent	4.61  4.6 3.3-3.5	Ten Mile River	6 certified operators on staff; big upgrade coming up soon, enhanced phosphorous and nitrogen removal
MA0101061	North Brookfield WWTP PO box 236 (mailing)	Rodney S. Jenkins  nbsewer@verizon.net	AS, EA, UV AdvTr,	0.76	Forget-me- not Brook	Sludge hauled via Synagro for incineration, 4

	59 East Brookfield Rd plant North Brookfield, MA 01535 (508) 867-0211 (508) 867-8196 (fax)		Nitr TR, INC	0.375		certified operators on staff; no plans for an upgrade
MA0101818	Northampton WWTF 33 Hockanum Road Northampton, MA 01060  (413) 587-1090	George Brehm gbrehm@nohodpw.org	AS  TR, LF  Approved Pretreatm ent	8.6 8.6 4.5	Connecticut River	Plant effluent pump station upgrade
MA0100722	Northbridge WWTF 644 Providence Road 7 Main St (mail) Whitinsville, MA 01588  (508) 234-2154	Mark Kuras Superintendent mkuras@northbridgemass. org	SBR, Nitr PRem, UV TR, INC	2 2 1.2	Unnamed Brook Blackstone River	4 certified operators on staff; future sludge conditioning, new holding tanks
MA0100200	Northfield WPCF 104 Meadow Street Northfield, MA 01360 (413) 498-5116	Chuck Neveu nwwtp@mtdata.com	AS, EA  TR, INC	0.275  0.125	Connecticut River	
	Oak Bluffs WWTP Pennsylvania Avenue Oak Bluffs, MA 02557 (508) 693-0343	Joseph Alosso jalosso@comcast.net	SBR AdvTr, Nrem, UV  TR	0.37  0.1	GW discharge	4 certified operators on staff; TOC upgrades; currently adding more nutricece, 250 gal/day more
M0101940	Old Deerfield WWTF 55 Little Meadow Road (plant) Old Deerfield, MA 01342 8 Conway Street South Deerfield, MA 01373 (413) 774-4595	Donald Chappell sdwwtp@verizon.net	AS, EA  TR, INC	0.25  0.15	Deerfield River	Sludge hauled to Fitchburg for incineration; 1 certified operator on staff; no plans for an upgrade
MA0101257	Orange WWTP 295 West Main Street (plant) PO Box 267 (mail) Orange, MA 01364 (978) 544-1114	Edward Billiel Jr wwtp@townoforage.org	AS, EA Cl, PRem  TR, INC	1.1  0.9	Millers River	3 certified operators on staff; looking at plant upgrade but is waiting for new permit before starting
1-187	Tritown GWPC WWTP  (Orleans/Brewster/Easth am)	James Burgess tritownplant@verizon.net	RBC, UV  SFilt, PT	0.045  0.045	GW Discharge	Sludge is hauled to Yarmouth POTW for composting and landfill; 5



	P.O. Box 2773 (mail) 29 Overland Way (plant)  Orleans, MA 02653 (508) 255-1150		TR, COMP, LF	0.032		certified operators on staff; for a year has been doing a sewer study; by 2015 this plant will be shut down and a new site will be built to handle 60% of the towns flow
MA0100170	Oxford-Rochdale SD WPCP 28 Comins Rd (plant) PO Box 246 (mailing) Rochdale, MA 01542 (508) 892-9549	Chief Operator/Supt  Robert F. Wilson orsd@aol.com	AS, AE, AL AdvTr, SFilt Nitr, PRem Cl, DChlo TR, INC	0.5  0.5 0.253	French River	2 certified operators on staff; has redone 1 of their 2 clarifiers so they are both 45
MA0101168	Palmer WWTF One Norbell Street Three Rivers, MA 01080  (413) 283-2671	Gerald Skowronek gerrys_palmerwwtp@yahoo.com	AS, AdvTr Prem Cl, DChlo TR, INC  Approved Pretreatm ent	5.6  1.6  CSO facility	Chicopee River	All remaining CSOs have been blocked but has until Dec 16th to make sure there is no cross connection; 5 certified operators on staff; just got their permit and is waiting for nitrogen level before an upgrade
MA0100064	Pepperell WWTF P.O. Box 319 (mail) 47 Nashua Rd (plant) Pepperell, MA 01463 (978) 433-9859	Laurie Stevens lstevens@town.pepperell.ma.us	AS, EA UV, PRem  TR, COMP	1.1 1.1 0.5	Nashua River	4 certified operators on staff; some sewer work has been done; no future upgrades planned
MA0101681	Pittsfield WWTP 901 Holmes Road Pittsfield, MA 01201 (413) 499-9304	Thomas Landry, Sup tlandry@pittsfieldch.com	TFilt, AdvTr, Nitr, DChlor, PT, Cl, Prem  TR, LF  Approved Pretreatm ent	17.0 17.0 12.0	Housatonic River	Sludge hauled to Moretown, VT to landfill; 14 certified operators on staff; town is doing an I&I study; looking at new backup power to replace outdated generators; in the middle of a SCADA project;

other upcoming projects include new barracks, solar energy project, a combine heat and power project, and going to diffused air; in the long term primary basins and grit collectoin system need to be upgraded, next 3-4 years

MA0100587	Plymouth WWTF 131 Camelot Drive Plymouth, MA 02360 (508) 830-4159	Gary Frizzell gfrizzell@townhall.plymouth h.ma.us	SBR, Dchlor TR, INC Approved Pretreatm ent	3.0  1.7	Plymouth Harbor & GW discharge	Sludge in thickened onsite and the liquid sludge is then hauled to Cranston RI for incineration; 7 certified operators on staff; in the next few months is going up to bid for an additional pump station on Long Pond Rd, about 50% of the design has been completed
MA0101923	Rockland WWTP 587 R Summer Street PO Box 330 Rockland, MA 02370 (781) 878-1964	John F. Loughlin, Supt JLoughlJ@yahoo.com	AS, EA, PT, Nitr, PRem Cl, DChlo AdvTr, SIrr TR, COMP Approved Pretreatm ent	2.5 2.5 2.4	French Stream	No planned upgrade at this time but waiting for permit Contract Ops - Aquaron operating systems
MA0100145	Rockport WWTP 46 Pleasant Street Rockport, MA 01966 (978) 546-7888	Larry Wonson dpwwtp@comcast.net	AS, EA  TR, COMP	0.8  0.85	Sandy Bay Atlantic Ocean	5 certified operators on staff; 3 more generators for pump stations; has recently updated most of equipment so no plans for an upgrade
MA0100161	Royalston WPCF Blossom Street		AS, EA	0.03	Millers River	Sludge hauled to Templeton

	South Royalston, MA 01374 (978) 249-3318		TR, LF			POTW; planning installation of new generator
MA0100960	Russell Village WWTF  200 Main Street P.O. Box 131 Russell, MA 01071 (413) 862-6215	Roger Bush, chief op  rabush@russellma.net	AS, EA  UV  TR, LF	0.24  0.09	Westfield River	Sludge hauled to Westfield POTW; 2 certified operators and 1 part time operator; no definite plans for an upgrade just some maintenance; some I&I work is being done; an engineer look at the plant and come up with a design, but is too expensive
MA0102873	Salisbury WWTF 125 Elm St Salisbury, MA 01952 (978) 465-4058	Jeff Ingalls wwtp@salisburyma.gov	AL, AdvTr Nitr, UV, SFilt On-site Storage, TR	1.3 0.75	Tidal creek to Merrimack River	3 certified operators on staff; no plans for an upgrade
MA0102695	Scituate WWTF 161 Driftway Scituate, MA 02066 (781) 545-8736	Robert P. Rowland, DPW Supervisor rrowland@town.scituate.ma.us	AS, AdvTr Nitr, DNitr, UV  TR, LF	1.6 1.183	Title Ditch Herring River North River Atlantic Ocean	Sludge hauled to Borne landfill; 5 certified operators on staff; allocated money and will upgrade the remaining pump stations to SCADA system; phase 3 of an expansion of the collection system, will be completed by end of August 2011
MA0101044	Shelburne Falls WWTF  17 State Street (mail) 16 Gardener Falls Rd Shelburne Falls, MA 01370 (413) 625-2300 (413) 625-8571 (fax)	Daniel M. Fleuier  sfwwtf@crocker.com	AS, EA  COMP	0.25  0.18	Deerfield River	Sludge disposed in reed beds for composting; standby power upgrade done; 2 certified operators on staff; 2 reed beds are scheduled for emptying in 2013; had a facility upgrade a couple years ago

MA0100676	Somerset WWTF 116 Walker Street Somerset, MA 02725 (508) 646-2868	Frank D. Arnold Harold Gracia swpc@meganet.net	AS	4.2	Taunton River	No upgrades planned in near future
			DChlor  Compost	3.7		
MA0101648	South Deerfield WWTP  150 Sunderland Road (plant) 8 Conway Street (mail)  South Deerfield, MA 01373 (413) 665-2651	Donald Chappell  Chief Operator  sdwwtp@verizon.net	AS, EA, Cl	0.85	Connecticut River	Sludge is hauled to Fitchburg for incineration; 2 certified operators on staff; no plans for an upgrade
				0.5		
			TR, INC			
MA0100501	South Essex Sewerage District 50 Fort Avenue P.O. Box 989 Salem, MA 01970 (978) 744-4550	Harold G. Newhall  Executive Director hnewhall@sesd.com	AS, POx DChlor	29.71	Salem Harbor	Contract No. 04-1 upgrade wastewater treatment plant underway; residuals management and odor control facilities; facility has 6 chief operators and 14 operators
			TR, LF Approved Pretreatm ent	28.09		
MA0100455	South Hadley WWTP 2 James Street Chicopee, MA 01020 (413) 538-5040	Melissa LaBonte -WPA Compliance Manager Mike Cijka - Operations	AS, Cl	4.2	Connecticut River	3 CSOs remaining; implementing a plant and pump station upgrade which will go out to bid around March 2006
			LF Approved Pretreatm ent	2.5 CSO facility		
MA0100901	Southbridge WWTP P.O. Box 1020 (mail) 83 Dresser Hill Rd (plant) Southbridge, MA 01550  (508) 764-4927	Paul A. Krasnecky paul.krasnecky@veoliawat erna.com	AS, AdvTr	3.77	Quinebaug River	5 certified operators on staff; SCADA upgrade; currently doing a phosphorous optimization to see what the levels are because of new limits; Contract Ops
			PRem, Nitr, Cl, DChlor BFilt, PT, ST COMP Approved Pretreatm ent	2.3		
MA0100919	Spencer WWTP 69 West Main Street Spencer, MA 01562 (508) 885-7542	Mark Robidoux, Supt mrobidoux@spencerma.go v	AS, AdvTr	1.08	Cranberry Brk Seven Mile River	2 certified operators on staff; pump station upgrade, just started design, will have some kind of SCADA at the plant
			EA, UV Nitr, PRem  TR, INC	0.4		
MA0101613	Springfield WWTP		AS,	64	Connecticut	Upgrading

	Bondi's Island Route 5 Springfield, MA 01103 (413) 787-6256		AdvTr DChlor, Nitr TR, COMP Approved Pretreatm ent	CSO Facility	River	SCADA and biosolids process; installing on-line monitoring equipment to track CSOs
MA0101087	Stockbridge WWTP #1 Rt 102 Stockbridge, MA 01262  (413) 298-4067	Anthony Campetti Sr. wwtp@townofstockbridge.com	AS, EA UV, OD PRem  TR	0.48 0.3 0.18	Housatonic River	Liquid sludge in hailed to Fitchburg for incineration (back up to Millbury); 3 certified operators on staff; will upgrade in the future if they are given nitrogen limits
MA0100421	Sturbridge WPCF P.O. Box 975 New Boston Rd Extension Sturbridge, MA 01566 (508) 347-2513 or 2514	Shane Moody shane.moody@veoliawater.com	AS, EA, AdvTr UV, Nitr, PRem  TR, INC	0.75 (1.4) 0.75 0.644	Quinebaug River	Sludge hauled to Cranston WPCF for INC; now comage instead of Sfilt and bimag for aeration; 5 certified operators on staff; upgrade will be completed by May 2012; expecting NPDES for Dec 1st 2011
MA0101079	Sunderland WWTP 113 River Road Sunderland, MA 01375  (413) 665-1447	Robert J. Garby Chief Operator selectmen@townofsunderland.us	AS, EA Cl  TR, INC	0.5  0.185	Connecticut River	Sludge hauled to Fitchburg WWTP for incineration; Changing from Chlorine gas to sodium hypochlorite
MA0100897	Taunton WWTP 825 West Water Street  Taunton, MA 02780 (508) 823-3582	Darlene Domingos darlene.domingos@veoliawater.com	PT, AS, Cl, DChlor Nitr AdvTr,  TR, LF Approved Pretreatm ent	9 8.4 7.2 CSO Facility	Taunton River	1 CSO remaining; 8 certified operators on staff; currently the city is doing a comprehensive wastewater plan for their CSO; Contract Ops

MA0100340	Templeton WWTP 33 Reservoir St Baldwinville, MA 01436 (978) 939-2743	Kent Songer krsonger@verizon.net	SBR UV  LF	0.6  0.253	Otter River	5 certified operators on staff; had an upgrade in the fall of 2004; has been doing minor upgrades including pump station upgrades, currently upgrading the last one
MA0102369	Upper Blackstone WPAD 50 Route 20 Millbury, MA 01527-2199 (508) 755-1286	T. K. Walsh tkwalsh@ubwpad.org www.ubwpad.org cleanriver@upwpad.org	RBC, AdvTr Nitr, DChlor Prem INC  Approved Pretreatment	45  32  CSO Facility	Blackstone River	Been in a \$180 million upgrade since 2001, into phase 3 of 4 for construction, phase 3 will be completed by 2012; 1 CSO remains, Adv Tr is seasonal treatment; 25 certified operators on staff
MA0100196	Upton WWTP 43 Maple Avenue West Upton, MA 01568  (508) 529-3993	Ronald San Souci, Sup rsansouci@upton.ma.us	AS, EA, Cl, Dchlo AdvTr, PRem, Nitr, SFilt  TR, INC	0.4 0.4 0.187- 0.23	Unnamed Brook West River	Sludge hauled by Synegro to incinerator; 5 certified operators that run both DW & WW plants; no plans for an upgrade
MA0102440	Uxbridge WWTF 80 River Road Uxbridge, MA 01569 (508) 278-2887	William Buma uxwwtf@charter.net	AS, AdvTr Nitr, PRem  TR, INC	2.5 2.5 1.1	Blackstone River	4.5 certified operators on staff; waiting for permit before making any changes
MA0100889	Ware WWTP 30 Robbins Rd Ware, MA 01082 (413) 967-9624 Chief Operator	Scott Potter spotter@townofware.com	AS, EA, AdvTr Nitr, PRem DChlor TR, INC	1.0  0.628	Ware River	Liquid sludge is hauled away for incineration; 3 certified operators on staff; no plans for an upgrade

			Approved Pretreatm ent			
MA0101893	Wareham WPCF 6 Tony's Lane Wareham, MA 02571 (508) 295-6144	Guy Campinna, director dasimrun@yahoo.com	AS, EA, UV AdvTr, PRem Nitr, DNitr  TR, LF	1.6 1.56 1.1	Agawam River	Finished upgrade to UV, PRem and controlled Nitr; ERP plan is being updated
MA010567	Warren WWTP PO Box 104 (mail) 2527 Main St. (plant) West Warren, MA 01092 (413) 436-5796	Shawn Romanski warrenwwtp@comcast.net	RBC Cl, Dchlo  TR, INC	1.5 1.5 0.316	Quaboag River	Sludge hauled to Upper Blackstone in Newbury; 3 certified operators on staff; waiting for new permit to see if they need to upgrade; capital plan study was done
MAW052725(60-2)	Wayland/Sudbury Septage Treatment Facility 490 Boston Post Road  Wayland, MA 01778 (508) 358-7328	Leonard Leonardi	RBC, SFilt DNitr  TR, INC	0.033  0.0245	GW Discharge	Denitrification and flow increase to 33,000 gpd; comprehensive evaluation & preliminary design submitted 1/31/06
MA0100439	Webster WWTF 38 Hill Street (plant) P.O. Box 793 (mail) Webster, MA 01570- 0793 (508) 949-3865	Harlan Hilton hhilton@webster-ma.gov	AS, AdvTr Nitr, DChlor PRem TR, INC Approved Pretreat ment	6.0	French River	5 certified operators on staff; just completed an active flow for phosphorous removal upgrade
MA0100412	Westborough WWTF 238 Turnpike Road Westborough, MA 01581 (508) 366-7615	Chris Pratt	AS, EA, OD, Nitr AdvTr, SFilt, DChlor PRem  TR, INC Approved Pretreatm ent	7.7	Assabet River	Comprehensive WW management plan on-going
MA0101800	Westfield WPCP 59 Court Street	Dave Billips d.billips@mail.ci.westfield.	AS, Cl, DChlor	6.1	Westfield River	Completed \$21M upgrade and

	Westfield, MA 01085 (413) 572-6268	ma.us	PRem Nitr, DNitr	4.1		expansion 1/05
			TR, LF Approved Pretreatm ent			
MA0100862	Winchendon WPCF 109 Front Street (637 River Street) Winchendon, MA 01475 (978) 297-0536	Richard M. Pezzoles winchendonwwtp@verizon .net	AS, EA, UV	1.1 0.6	Millers River	2 certified operators on staff; had an upgrade in 2006
			TR, INC			
MA0103233	Woronoco Village WWTF 200 Main Street P.O. Box 131 Russell, MA 01071 (413) 862-6215	Roger Bush rabush@russellma.net	ST, SFilt, UV	0.021 0.003	Westfield River	Sludge hauled to Westfield POTW; 2.5 operators shared with Russell Village WWTP; Sfilt sand will be replaced soon
	Yarmouth-Dennis Septage	Dave Bernier, project manager	AS, EA, OD	0.1	GW discharge	Sludge hauled to Maine for composting; 4 certified operators on staff; upgraded treatment processes to include ozone and tercerary; possible upgrade, will be decided in Sept 2011



## Appendix C: UBWPAD Influent Flow Data

*Table 15 - UBWPAD Wastewater Influent Flow Data*

<i>Date/Time</i>	<i>Hour</i>	<i>Hourly Flow (MGD)</i>
1/1/13 1:00	1	21.93750572
1/1/13 2:00	2	19.66189194
1/1/13 3:00	3	17.82133675
1/1/13 4:00	4	18.89783859
1/1/13 5:00	5	18.48766708
1/1/13 6:00	6	16.46675682
1/1/13 7:00	7	15.47485447
1/1/13 8:00	8	18.01708221
1/1/13 9:00	9	18.87311554
1/1/13 10:00	10	19.72144318
1/1/13 11:00	11	23.760355
1/1/13 12:00	12	22.36583328
1/1/13 13:00	13	31.47485924
1/1/13 14:00	14	31.40472221
1/1/13 15:00	15	26.69984055
1/1/13 16:00	16	31.51247978
1/1/13 17:00	17	26.17496109
1/1/13 18:00	18	24.0252018
1/1/13 19:00	19	24.67366409
1/1/13 20:00	20	27.4358902
1/1/13 21:00	21	23.00626373
1/1/13 22:00	22	21.57201576
1/1/13 23:00	23	19.61362648

## Appendix D: Manufacturer Information

All information provided in this section was not altered in any way and was obtained from Toshiba's web site.

Turbine Specifications  
*Toshiba Hydro-eKIDS Product Range*

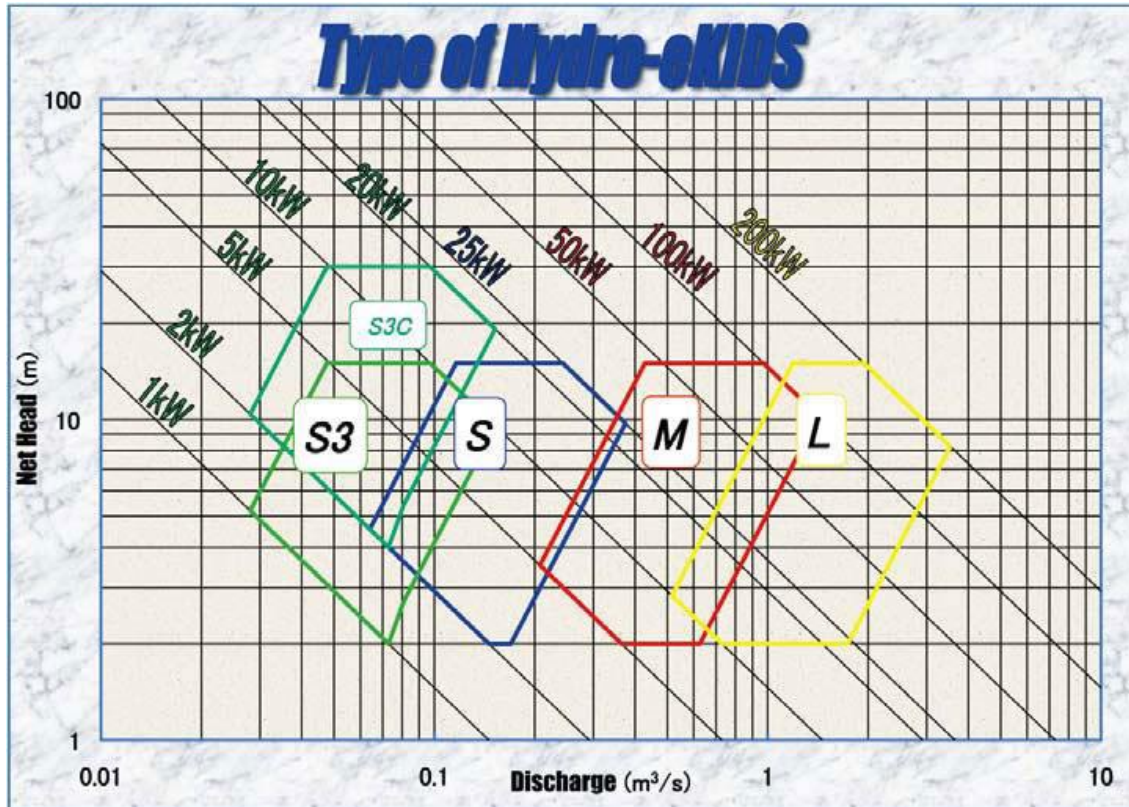

Type		L	M	S	S3	S3C
Dimension	L (mm)	4600	2050	1260	800	1200
	W (mm)	1600	1110	600	550	550
	H (mm)	2500	1700	1000	900	900
Diameter of Pipe Flange (Inflow)	A (mm)	1350	600	300	200	200
Diameter of Pipe Flange (Outflow)	A (mm)	1000	600	300	200	200
Weight (Turbine & Generator)*1	Ton	7.5	3.1	1.0	0.5	0.6

\*1: The weights will be changed dependent upon capacity, type, and rotating speed of the generators.

## Arrangements

### *Parallel Arrangement*



This arrangement uses multiple units installed in parallel for when water discharge exceeds the capacity of a single unit. Either unit can easily be started or stopped, depending on the available flow.

### *Cascade Arrangement*



Cascade arrangement uses multiple units installed in series when the available head exceeds maximum head of a single unit. Every unit in the series shares water head equally.

## Basic Installation

Since the turbine and generator are pre-set as a package, Hydro-eKIDS are easily installed on a simple foundation and require only a small space for installation and no centering-work.

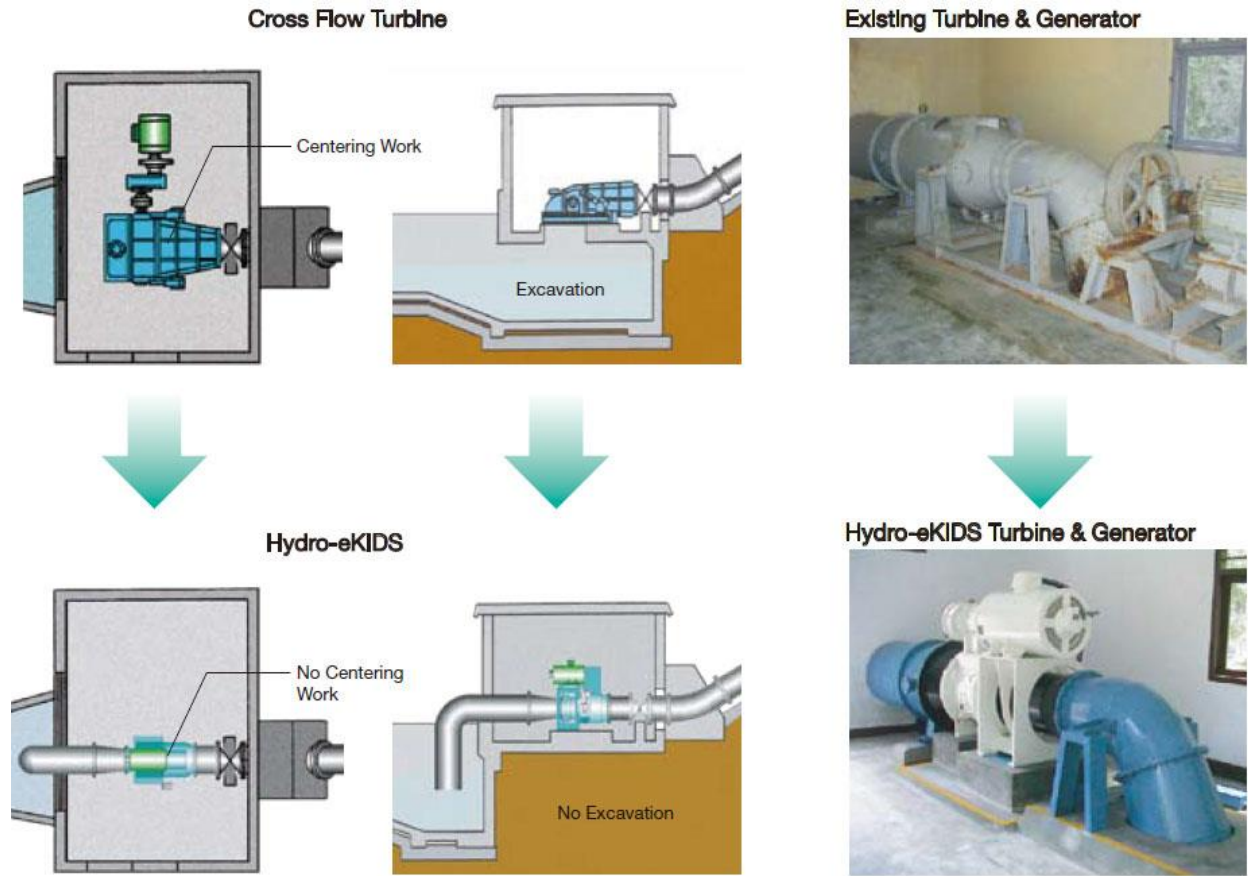

## Installation Examples

### Case 1

#### Multipurpose/Irrigation Dam

Type : Type-M  
Output : 200 kW  
Head : 30m  
Generator : Synchronous  
Voltage : 3 Phase 380V



### Case 2

#### Water Treatment Plant

Type : Type-M  
Output : 75kW  
Head : 11.76m  
Generator : Induction  
Voltage : 3 Phase 440V



### Case 3

#### Sewage Treatment Plant

Type : Type-M  
Output : 9.0kW  
Head : 2.0m  
Generator : Induction  
Voltage : 3 Phase 200V



### Case 4

#### Industrial Water

Type : Type-S3C  
Output : 9.8kW  
Head : 25m  
Generator : Induction  
Voltage : 3 Phase 420V



### Case 5

#### HVAC System

Type : Type-S3C  
Output : 4.4kW  
Head : 25m  
Generator : Alternator  
Voltage : DC 24V



## Design Features

### *Runner & Guide Vanes*

Optimum selection is selected with a number of: runner blades, adjusting runner blades and guide vanes opening depending on site conditions such as head, discharge and cavitation.

Runner blades and guide vanes are made from stainless steel castings.

### *Generator*

Optimum selection is a choice between induction and synchronous generators, depending if the Hydro-eKIDS will be connecting to or independent from the grid.

Bearings are standard roller-type and lubricated with grease.

### *Turbine shaft*

Turbine shaft is designed with vibration analysis by FEM and also static strength analysis so as to withstand runaway speed such as that in large capacity turbines.

Turbine shaft is made of stainless steel.

### *Turbine bearing*

The bearing system combines a tapered roller type which withstands axial thrust and radial load, and cylindrical roller type for radial load.

Bearing is lubricated with oil of VG-46 or equivalent.

### *Shaft seal*

Shaft seal is a mechanical type that self-lubricates with water.

Materials are ceramic or carbon.



Application & Connections

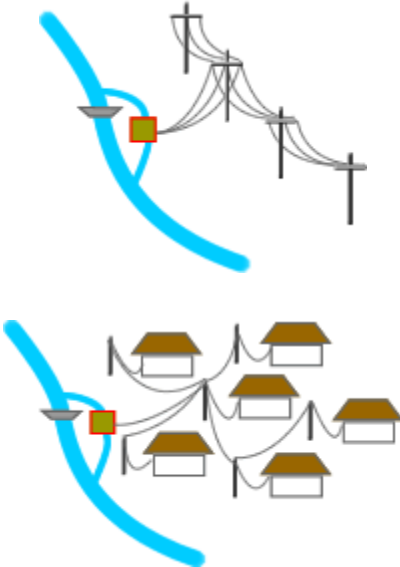

## LH1000 Low Head Stream Engine

"Home of the Stream Engine™"

*Buy directly from the inventor and manufacturer.*

The LH 1000 uses the same generator as the Stream Engine, however the water turbine component uses a low head propeller design.

This enables the machine to produce power from heads of 0.5 metres (2 feet) up to 3 metres (10 feet). At the maximum head, the output is 1 Kw.

### FEATURES:

- Axial Flow Propeller Turbine
- Adjustable output Permanent Magnet Alternator
- Non-corrosive precision made parts.
- Operates on heads of 2' -10'
- Explanatory manual and multi-meter included.
- Straightforward installation
- 1 year Warranty.

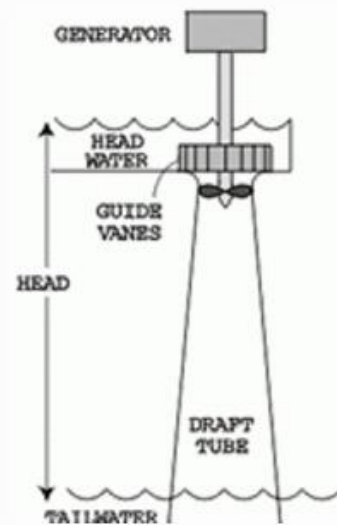

The Low Head 1000, is designed to operate in conjunction with battery based power systems, storing electrical power for use at times when consumption exceeds generation.

To gain enough head to operate the LH1000, water is channelled into a sluiceway. the turbine is mounted in a 18cm (7") diameter opening in the sluice bottom, with the draft tube extending to

the tailwater below.

The water turns the propeller, creating shaft power. This in turn powers the generator producing electricity. This machine is suited for sites that do not have much head (vertical drop) but have a lot of water (500-1000 gallons per minute).

Typically, these systems operate at 12, 24, 48 or 120 volts.

The LH1000 can be specially wound to operate at 240 volts if necessary, employing an adjustable, permanent magnet generator and reconnectable wiring.

A low volume propeller is available which will use half the water and produce half the power for any given head.



## Turbine Specifications

### PowerPal



Electricity from Water with PowerPal

Phone: 1.250.361.4348 Fax: 1.250.360.9012

Products

About Us

Contact us

Where we are

Download

Product Manuals

Site Map

Home

Micro-hydro Forum

Email

#### PowerPal Product Line

Low Head

High Head

T1 and T2 Turgo

T5 Turgo

T8 and T16 Turgo

#### PowerPal Low Head

Models MHG-200LH, MHG-500LH and MHG-1000LH

Power outputs: 200W - 1000W



A simple AC single-phase, brushless permanent magnet alternator is attached to a propeller turbine. All or part of the stream flow is diverted into an intake canal where it forms a vortex, causing the propeller to rotate as it exits through a draft tube to flow free again. All that is required is a vertical drop (head) and a sufficient rate of water flow, which are commonly obtained by installing PowerPal on a small waterfall, dam or diversion trench.

Electricity passes along a wire and into a house, where an electronic load controller (supplied) stabilizes the voltage to 110V or 220V to protect electrical appliances during use. Being lightweight and portable, installation is very simple and is explained in the Instruction Manual. Once installed there are no running costs and maintenance costs are extremely low.

	MHG-200LH	MHG-500LH	MHG-1000LH
<b>Water head</b>	<b>1.5 m</b>	<b>1.5 m</b>	<b>1.5 m</b>
<b>Water flow</b>	<b>35 l / sec</b>	<b>70 l / sec</b>	<b>130 l / sec</b>
<b>Output Power</b>	<b>200W</b>	<b>500W</b>	<b>1000W</b>

[View Low Head in Use](#)

[Download product manual](#)

## HydroCoil ® Turbine for Micro Hydro Electric Power Generation

# HydroCoil Power, Inc.



1. HOME

2. SITES & INSTALLATION

3. TECHNOLOGY

4. APPLICATIONS & BENEFITS

5. DEMONSTRATION

6. ABOUT US

7. CONTACT

### The HydroCoil design--revolutionizes low head, micro hydro.

#### Innovations used for the most consistent energy transfer:

- Varying coil angles of the HydroCoil helical turbine -->
  - to extract and incrementally convert kinetic energy of water inside this micro hydro electric turbine, which sequentially captures linear energy of water transitting the gradual to steeper coils
  - mathematical plus the practical
  - design includes key and not-so-obvious physics principles
  - NO vibration
- gravity--or pressure of flow in a pipe/ conduit/ channel-- is the energy source for HydroCoil turbines

- potential energy in head or existing elevated storage
- kinetic energy in water flow, water treatment, low head dams, cascades, tidal change.
- plus a pump? No, just for the demo. Don't need a high pressure or high velocity circuit as with some horizontal, in-pipe, high-head turbines
- outer containment cylinder:
  - to focus energy of pipe outflow/ sluiceway/ irrigation canal/ river/ ocean current
  - essentially all of the water contacts the turbine coils
- internal strength in its torsional dynamism
- root torsional bending stress is constantly distributed, which
  - helps minimize vane thickness & its concave base fillet
  - advantageous to durability and to cost factor
- side vents (optional, for variable flow conditions)
  - for early water exit from turbine if momentary pressure backup during current changes
- *this is NOT an Archimedes screw; it outperformed an Archimedes screw early-on*
- *this is NOT a modification of traditional turbines such as Kaplan, crossflow, or Pelton wheel*
- *this does NOT vibrate*

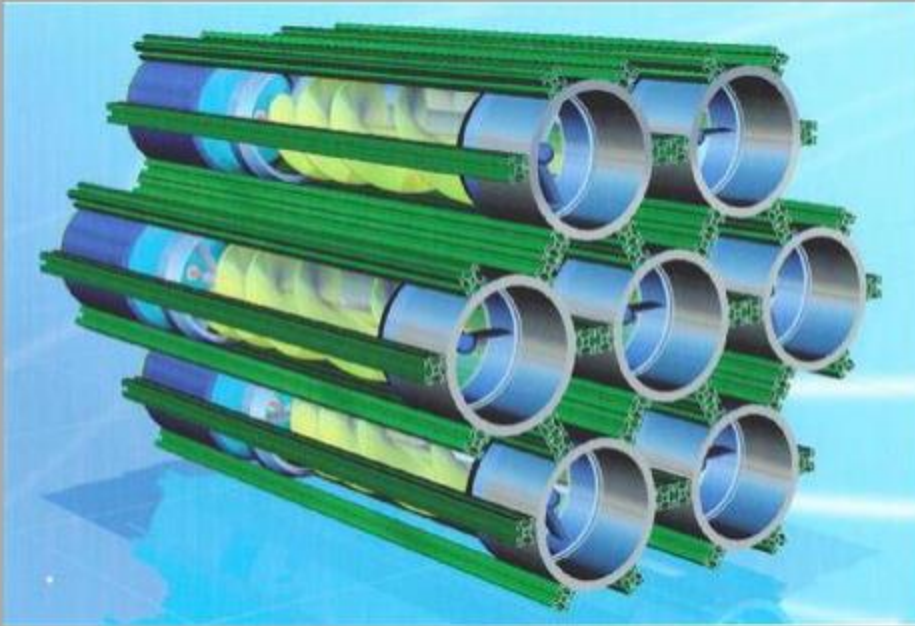

CLUSTER of 7 HydroCoil units, like a honeycomb. Turbines READILY CONNECTED SIDE-TO-SIDE. Can expand cluster, or REMOVE SINGLE UNITS for service.

### **HydroCoil Turbine development:**

#### Development, Consultation and Assessment :

HydroCoilPower the Company was founded by Dr. Rosefsky, who theorized and pioneered the HydroCoil technology. HydroCoil turbines started right here, and continue to advance with new patents.

Advice and assistance from the engineering departments at Drexel, Villanova, and Cooper Union universities, early in development. Ben Franklin Technology Partners awarded a grant.

Working with 3-D Technologies of Avondale, PA ( <http://mywebpages.comcast.net/3dtech> ), the design underwent internal improvements. Definitive demonstrations (video, p.5) and certification. Results were beyond expectations, with efficiency above the norm for low head hydro.

## Turbine Specifications

### Canyon Turbine

## Micro-Hydro Systems

### Smaller Hydropower Systems less than 100kW

*For larger Utility/IPP systems, please [click here](#).*

Canyon Hydro designs and manufactures small hydro systems ranging from 4kW to 25MW. Each system is designed and built at our manufacturing facilities in the USA.

For our customers with residential or small community projects, Canyon Hydro provides a broad selection of micro-hydro systems up to about 100kW, each delivering high efficiency, quality and reliability at a reasonable cost. If you have requirements for larger systems, please refer to Canyon Hydro [Utility/IPP Systems](#).

You can purchase a complete hydro system from Canyon Hydro, or individual components. We will be happy to work with you to determine the best approach. A typical hydro system from Canyon includes the following components:

- Water turbine and housing
- Drive system
- Generator
- Electronic Governor
- Assembly Frame

In addition, many of our systems are equipped with one or more of the following options:

- Stainless steel runner
- Variable needle nozzle
- Frequency protection jet deflector

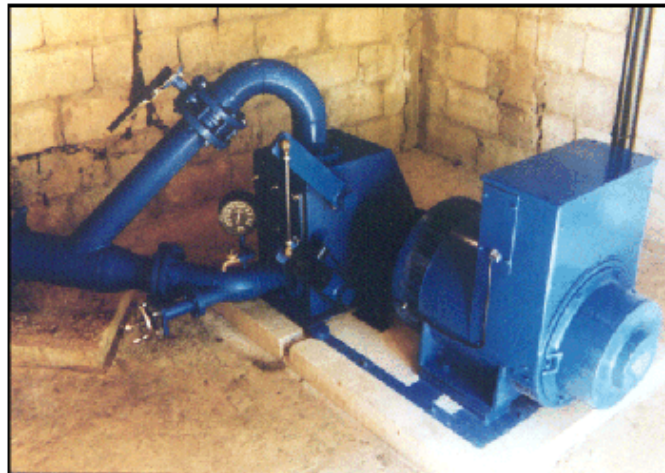

*This dual-jet system, located in Costa Rica, drives a 14kW generator, and uses a needle nozzle to allow adjustment for changing flow conditions without shutting the system down.*

## Canyon Standard Turbines

The heart of a Canyon Hydro system is the water turbine. Efficiency counts most here, and we take great care to ensure maximum power transfer. Canyon Pelton runners are all-metal, cast as a single unit. Bucket tip, splitter and exit angles maximize the transfer of hydraulic energy to the turbine shaft. Each bucket is hand-polished, with special attention directed to the rear of the bucket to minimize internal aerodynamic drag.

Similar procedures are employed for Canyon Crossflow and Francis turbines, using the highest quality materials and advanced manufacturing techniques.

Most importantly, Canyon turbines are backed by a group of experienced professionals who know hydro systems, and are dedicated to the success of your project.

---



### Canyon Will Design Your Turbine System

We strongly recommend that you let Canyon Hydro design the proper turbine system for your site, because the most efficient system involves many complex factors. **There is no charge for this service.**



*Canyon Hydro Manganese Bronze Pelton runner.*

Beginning with your measurements of HEAD and FLOW, Canyon experts will specify the right combination of turbine type, diameter, bucket or blade characteristics, nozzle sizing, shaft speed, housing dimensions, and more. We think it's important that you get the most power possible for your investment.

The most essential information we require is *accurate* HEAD and FLOW measurements. Eventually, we'll also need information about your pipeline and electrical requirements, but we can assist you with defining them once we know your HEAD and FLOW.

You can learn more about HEAD and FLOW, and how to measure it, in our [Guide to Hydro Power](#).

To get started, simply fill out our [data sheet](#) and send it to us.

### Representative Canyon Turbine Specifications

Canyon Hydro produces a wide array of turbine systems, making it possible to closely match your site characteristics for optimum efficiency. See the accompanying chart for performance [specifications](#) on five representative models.

---

## Appendix E: Solid Model Drawings

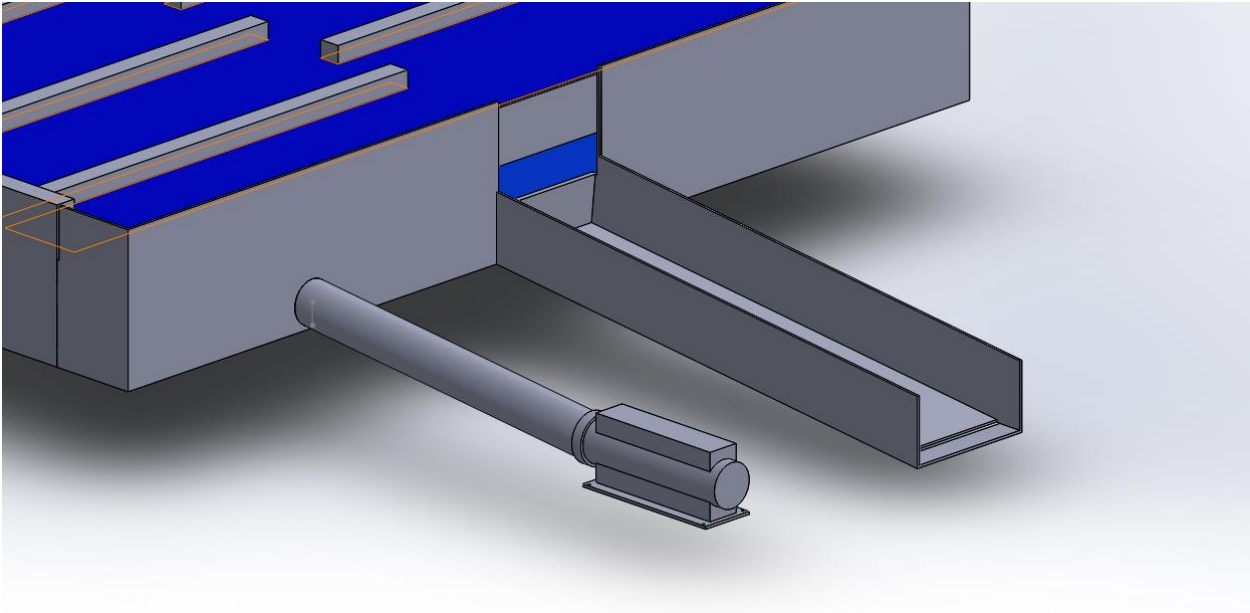
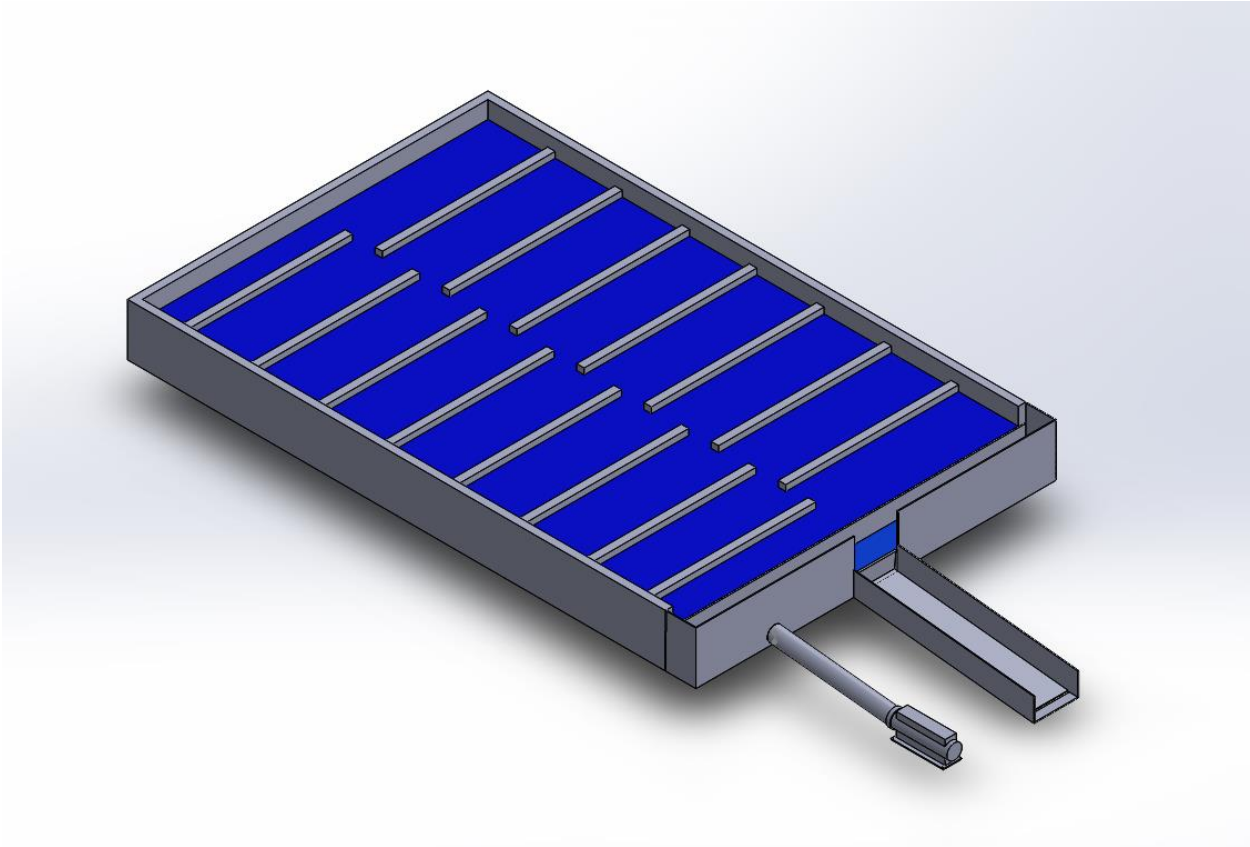

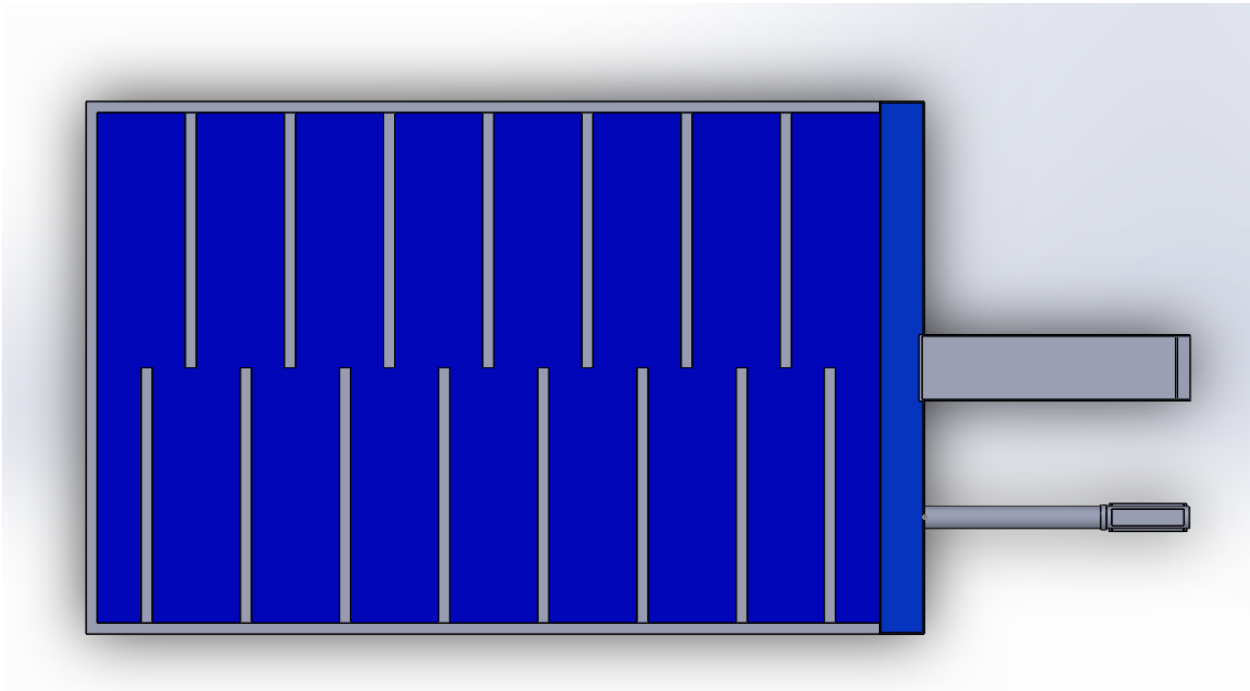

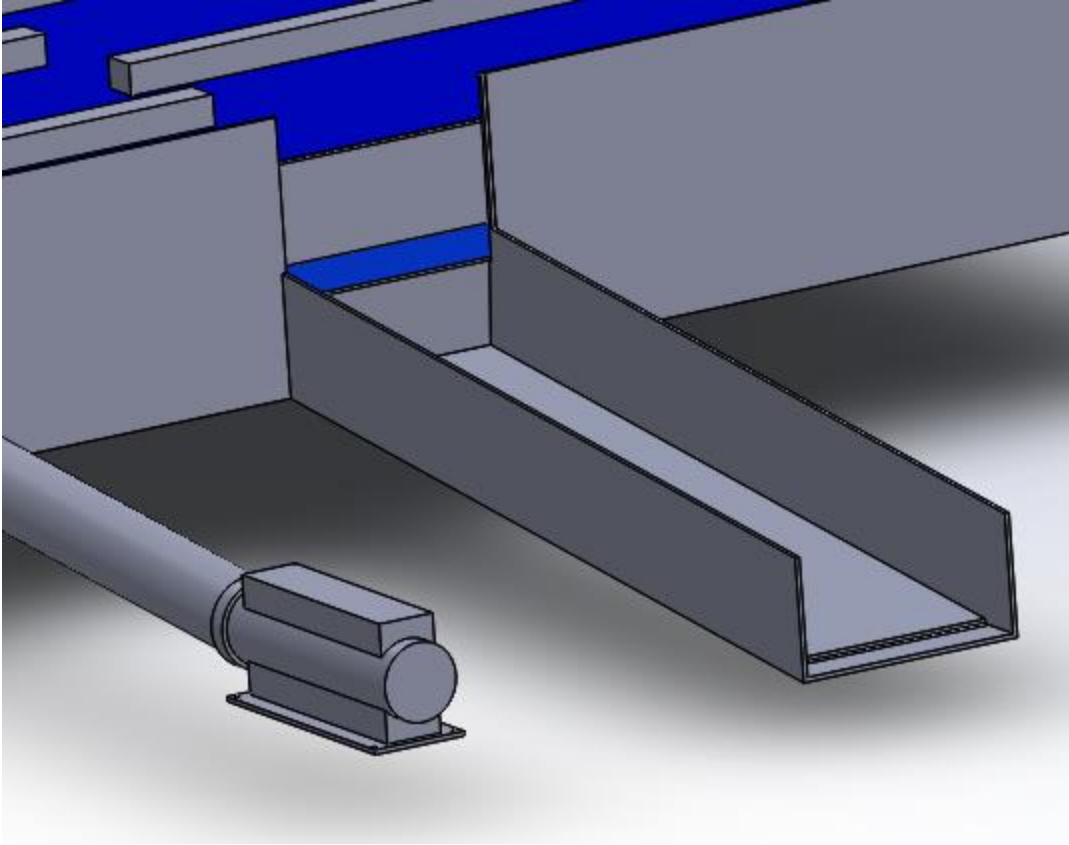

## Appendix F: Hypothetical Case Tables

Table 16 - Potential Power Generation (kWh) of Hypothetical Flow and Head Cases

Flow (MGD)	Head (Feet)														
	6	7	8	9	10	12	14	16	18	20	30	40	50		
2	1.3	1.6	1.8	2.0	2.2	2.7	3.1	3.6	4.0	4.4	6.7	8.9	11.1		
4	2.7	3.1	3.6	4.0	4.4	5.3	6.2	7.1	8.0	8.9	13.3	17.8	22.2		
6	4.0	4.7	5.3	6.0	6.7	8.0	9.3	10.7	12.0	13.3	20.0	26.6	33.3		
8	5.3	6.2	7.1	8.0	8.9	10.7	12.4	14.2	16.0	17.8	26.6	35.5	44.4		
10	6.7	7.8	8.9	10.0	11.1	13.3	15.5	17.8	20.0	22.2	33.3	44.4	55.5		
12	8.0	9.3	10.7	12.0	13.3	16.0	18.7	21.3	24.0	26.6	40.0	53.3	66.6		
14	9.3	10.9	12.4	14.0	15.5	18.7	21.8	24.9	28.0	31.1	46.6	62.2	77.7		
16	10.7	12.4	14.2	16.0	17.8	21.3	24.9	28.4	32.0	35.5	53.3	71.1	88.8		
18	12.0	14.0	16.0	18.0	20.0	24.0	28.0	32.0	36.0	40.0	60.0	79.9	99.9		
20	13.3	15.5	17.8	20.0	22.2	26.6	31.1	35.5	40.0	44.4	66.6	88.8	111.0		
22	14.7	17.1	19.5	22.0	24.4	29.3	34.2	39.1	44.0	48.8	73.3	97.7	122.1		
24	16.0	18.7	21.3	24.0	26.6	32.0	37.3	42.6	48.0	53.3	79.9	106.6	133.2		
26	17.3	20.2	23.1	26.0	28.9	34.6	40.4	46.2	52.0	57.7	86.6	115.5	144.3		
28	18.7	21.8	24.9	28.0	31.1	37.3	43.5	49.7	56.0	62.2	93.3	124.3	155.4		
30	20.0	23.3	26.6	30.0	33.3	40.0	46.6	53.3	60.0	66.6	99.9	133.2	166.5		
32	21.3	24.9	28.4	32.0	35.5	42.6	49.7	56.8	63.9	71.1	106.6	142.1	177.6		
34	22.6	26.4	30.2	34.0	37.7	45.3	52.8	60.4	67.9	75.5	113.2	151.0	188.7		
36	24.0	28.0	32.0	36.0	40.0	48.0	56.0	63.9	71.9	79.9	119.9	159.9	199.8		
38	25.3	29.5	33.8	38.0	42.2	50.6	59.1	67.5	75.9	84.4	126.6	168.8	210.9		
40	26.6	31.1	35.5	40.0	44.4	53.3	62.2	71.1	79.9	88.8	133.2	177.6	222.0		
42	28.0	32.6	37.3	42.0	46.6	56.0	65.3	74.6	83.9	93.3	139.9	186.5	233.1		
44	29.3	34.2	39.1	44.0	48.8	58.6	68.4	78.2	87.9	97.7	146.5	195.4	244.2		
46	30.6	35.7	40.9	46.0	51.1	61.3	71.5	81.7	91.9	102.1	153.2	204.3	255.3		

Table 17 - Annual Savings for Hypothetical Flow and Head Cases

Flow (MGD)	Head (Feet)												
	6	7	8	9	10	12	14	16	18	20	30	40	50
2	\$ 1,167	\$ 1,362	\$ 1,556	\$ 1,751	\$ 1,945	\$ 2,334	\$ 2,723	\$ 3,112	\$ 3,501	\$ 3,890	\$ 5,835	\$ 7,780	\$ 9,725
4	\$ 2,334	\$ 2,723	\$ 3,112	\$ 3,501	\$ 3,890	\$ 4,668	\$ 5,446	\$ 6,224	\$ 7,002	\$ 7,780	\$ 11,670	\$ 15,561	\$ 19,451
6	\$ 3,501	\$ 4,085	\$ 4,668	\$ 5,252	\$ 5,835	\$ 7,002	\$ 8,169	\$ 9,336	\$ 10,503	\$ 11,670	\$ 17,506	\$ 23,341	\$ 29,176
8	\$ 4,668	\$ 5,446	\$ 6,224	\$ 7,002	\$ 7,780	\$ 9,336	\$ 10,892	\$ 12,448	\$ 14,005	\$ 15,561	\$ 23,341	\$ 31,121	\$ 38,902
10	\$ 5,835	\$ 6,808	\$ 7,780	\$ 8,753	\$ 9,725	\$ 11,670	\$ 13,616	\$ 15,561	\$ 17,506	\$ 19,451	\$ 29,176	\$ 38,902	\$ 48,627
12	\$ 7,002	\$ 8,169	\$ 9,336	\$ 10,503	\$ 11,670	\$ 14,005	\$ 16,339	\$ 18,673	\$ 21,007	\$ 23,341	\$ 35,011	\$ 46,682	\$ 58,352
14	\$ 8,169	\$ 9,531	\$ 10,892	\$ 12,254	\$ 13,616	\$ 16,339	\$ 19,062	\$ 21,785	\$ 24,508	\$ 27,231	\$ 40,847	\$ 54,462	\$ 68,078
16	\$ 9,336	\$ 10,892	\$ 12,448	\$ 14,005	\$ 15,561	\$ 18,673	\$ 21,785	\$ 24,897	\$ 28,009	\$ 31,121	\$ 46,682	\$ 62,242	\$ 77,803
18	\$ 10,503	\$ 12,254	\$ 14,005	\$ 15,755	\$ 17,506	\$ 21,007	\$ 24,508	\$ 28,009	\$ 31,510	\$ 35,011	\$ 52,517	\$ 70,023	\$ 87,528
20	\$ 11,670	\$ 13,616	\$ 15,561	\$ 17,506	\$ 19,451	\$ 23,341	\$ 27,231	\$ 31,121	\$ 35,011	\$ 38,902	\$ 58,352	\$ 77,803	\$ 97,254
22	\$ 12,837	\$ 14,977	\$ 17,117	\$ 19,256	\$ 21,396	\$ 25,675	\$ 29,954	\$ 34,233	\$ 38,512	\$ 42,792	\$ 64,187	\$ 85,583	\$ 106,979
24	\$ 14,005	\$ 16,339	\$ 18,673	\$ 21,007	\$ 23,341	\$ 28,009	\$ 32,677	\$ 37,345	\$ 42,014	\$ 46,682	\$ 70,023	\$ 93,364	\$ 116,705
26	\$ 15,172	\$ 17,700	\$ 20,229	\$ 22,757	\$ 25,286	\$ 30,343	\$ 35,400	\$ 40,458	\$ 45,515	\$ 50,572	\$ 75,858	\$ 101,144	\$ 126,430
28	\$ 16,339	\$ 19,062	\$ 21,785	\$ 24,508	\$ 27,231	\$ 32,677	\$ 38,123	\$ 43,570	\$ 49,016	\$ 54,462	\$ 81,693	\$ 108,924	\$ 136,155
30	\$ 17,506	\$ 20,423	\$ 23,341	\$ 26,259	\$ 29,176	\$ 35,011	\$ 40,847	\$ 46,682	\$ 52,517	\$ 58,352	\$ 87,528	\$ 116,705	\$ 145,881
32	\$ 18,673	\$ 21,785	\$ 24,897	\$ 28,009	\$ 31,121	\$ 37,345	\$ 43,570	\$ 49,794	\$ 56,018	\$ 62,242	\$ 93,364	\$ 124,485	\$ 155,606
34	\$ 19,840	\$ 23,146	\$ 26,453	\$ 29,760	\$ 33,066	\$ 39,680	\$ 46,293	\$ 52,906	\$ 59,519	\$ 66,133	\$ 99,199	\$ 132,265	\$ 165,331
36	\$ 21,007	\$ 24,508	\$ 28,009	\$ 31,510	\$ 35,011	\$ 42,014	\$ 49,016	\$ 56,018	\$ 63,020	\$ 70,023	\$ 105,034	\$ 140,045	\$ 175,057
38	\$ 22,174	\$ 25,870	\$ 29,565	\$ 33,261	\$ 36,956	\$ 44,348	\$ 51,739	\$ 59,130	\$ 66,522	\$ 73,913	\$ 110,869	\$ 147,826	\$ 184,782
40	\$ 23,341	\$ 27,231	\$ 31,121	\$ 35,011	\$ 38,902	\$ 46,682	\$ 54,462	\$ 62,242	\$ 70,023	\$ 77,803	\$ 116,705	\$ 155,606	\$ 194,508
42	\$ 24,508	\$ 28,593	\$ 32,677	\$ 36,762	\$ 40,847	\$ 49,016	\$ 57,185	\$ 65,355	\$ 73,524	\$ 81,693	\$ 122,540	\$ 163,386	\$ 204,233
44	\$ 25,675	\$ 29,954	\$ 34,233	\$ 38,512	\$ 42,792	\$ 51,350	\$ 59,908	\$ 68,467	\$ 77,025	\$ 85,583	\$ 128,375	\$ 171,167	\$ 213,958
46	\$ 26,842	\$ 31,316	\$ 35,789	\$ 40,263	\$ 44,737	\$ 53,684	\$ 62,631	\$ 71,579	\$ 80,526	\$ 89,473	\$ 134,210	\$ 178,947	\$ 223,684



Table 18 - Payback Periods (Years) of Hypothetical Flow and Head Cases

Flow (MGD)	Head (Feet)														
	6	7	8	9	10	12	14	16	18	20	30	40	50		
2	42	36	32	28	25	21	18	16	14	13	8	6	5		
4	21	18	16	14	13	11	9	8	7	6	4	3	3		
6	14	12	11	9	8	7	6	5	5	4	3	2	2		
8	11	9	8	7	6	5	5	4	4	3	2	2	1		
10	8	7	6	6	5	4	4	3	3	3	2	1	1		
12	7	6	5	5	4	4	3	3	2	2	1	1	1		
14	6	5	5	4	4	3	3	2	2	2	1	1	1		
16	5	5	4	4	3	3	2	2	2	2	1	1	1		
18	5	4	4	3	3	2	2	2	2	1	1	1	1		
20	4	4	3	3	3	2	2	2	1	1	1	1	1		
22	4	3	3	3	2	2	2	1	1	1	1	1	<1		
24	4	3	3	2	2	2	2	1	1	1	1	1	<1		
26	3	3	2	2	2	2	1	1	1	1	1	<1	<1		
28	3	3	2	2	2	2	1	1	1	1	1	<1	<1		
30	3	2	2	2	2	1	1	1	1	1	1	<1	<1		
32	3	2	2	2	2	1	1	1	1	1	1	<1	<1		
34	2	2	2	2	1	1	1	1	1	1	<1	<1	<1		
36	2	2	2	2	1	1	1	1	1	1	<1	<1	<1		
38	2	2	2	1	1	1	1	1	1	1	<1	<1	<1		
40	2	2	2	1	1	1	1	1	1	1	<1	<1	<1		
42	2	2	2	1	1	1	1	1	1	1	<1	<1	<1		
44	2	2	1	1	1	1	1	1	1	1	<1	<1	<1		
46	2	2	1	1	1	1	1	1	1	1	<1	<1	<1		