



Fire Safety of Solar Photovoltaic Systems in Australia

**The Alternative Technology Association
Sponsor**

Project Centre: Melbourne, Australia D-Term 2016

Submitted by:

Alessandra Chiamonte, Austin Smith, Zachary Hood

Project Advisors:

Professor Holly Ault & Professor James Hanlan

Worcester Polytechnic Institute

Submitted to:

Mr. Damien Moyse & Mr. Andrew Reddaway

Alternative Technology Association

Date:

May 4th, 2016

This report represents the work of WPI undergraduate students submitted to the faculty as evidence of completion of a degree requirement. WPI routinely publishes these reports on its website without editorial or peer review. For more information about the projects program at WPI, please see <http://www.wpi.edu/academics/ugradstudies/project-learning.html>.

Abstract

Solar PV systems contribute to an increase in the probability of a fire occurring, primarily due to electrical risks. Through collaboration with the Alternative Technology Association, fire services personnel, solar PV installers, and other regulatory organisations, we identified fire risks associated with solar PV systems and investigated how the presence of solar PV systems can affect homeowners. An informational guide was produced for homeowners to raise public awareness and provide suggestions to mitigate fire risks associated with solar PV installations.

Executive Summary

In Australia, currently 4 million people live underneath a solar roof. Solar photovoltaic (PV) systems are a common renewable technology utilised by consumers. As of 2015, government rebates and high feed-in tariffs have led to over 1.5 million installations that cumulatively produce approximately 5,000 GigaWatt-Hours of energy annually (CEC, 2015b). In concert with the growth of the solar industry, the number of recorded solar-related fires has also increased. Solar PV installations have been proposed to increase the risk of a household fire.

The Alternative Technology Association (ATA) is non-for-profit organisation that inspires people to live sustainably in their homes and communities. The ATA has sought to understand the fire risks associated with solar PV systems through research in identifying the causes of solar-related fires, assessing Australian fire services response to solar-related fires, and analysing safety regulations for solar PV systems. As a result of these findings, the ATA was interested in raising awareness of proactive steps homeowners could perform to mitigate fire risks associated with solar PV systems.

Methodology:

To achieve our project goals, we established three main research objectives:

1. Identify Fire Risks Associated with Solar PV Components
2. Compile Firefighter Standard Operational Procedures
3. Analyse Current Safety Regulations for Solar PV Installations

Our team sought to gather information from different individuals involved with solar PV systems: accredited solar installers, Australian fire operational personnel, and product safety regulators. In addition, we retrieved aggregate data from the Australasian Fire and Emergency Service Authorities Council (AFAC) to put into perspective the risks incurred by solar PV systems. We utilised the following research methods to complete our project:

1. Retrieved aggregate data from AFAC's Fire Investigation Network
2. Conducted interviews with 48 solar accredited installers in Australia
3. Conducted interviews with informed sources at several U.S. and Australian fire services

4. Obtained current firefighter training documentation from fire services
5. Contacted an Australian product safety regulator
6. Researched Australian electrical standards and regulations for solar installations

Findings:

1. Isolators and inverters are the main causative agents in solar-related fires.

Data were collected through the Australasian Fire and Emergency Services Authorities Council (AFAC) and Fire & Rescue New South Wales (FRNSW) pertaining to solar-related fires. From 2009 to 2015, 52% of recorded solar-related fires in Western Australia and New South Wales were caused by an inverter or isolator component. Causative agents were not identified for a large percentage of the remaining recorded solar-related fires. Other causative agents of solar-related fires included electrical wiring and the main switchboard.

2. Additional risks associated with solar PV systems that can affect homeowners and firefighters include electrical shock as well as component failure and degradation.

These risks can increase after a severe storm or flood. Homeowners' lack of awareness on how to properly maintain their solar PV system can also lead to increased fire risk. Additional fire risks may hinder firefighter operation and increase safety concerns.

3. Energy storage industry will expand as prices for storage batteries decrease and feed-in tariffs decline.

Many solar installer survey respondents stated that storage batteries will become a popular addition to on-grid solar PV systems. The conclusion of 2016 will end high feed-in tariffs in multiple states, which will make selling electricity back to the grid less profitable. The decrease in feed-in tariff rates across Australian states can lead to an increase in storage battery installations.

4. There is a lack of standards and accreditation for battery storage installations to on-grid solar PV systems.

A major area of concern for solar installers is the lack of installation standards for battery storage systems. With rapidly advancing storage battery technologies, standards have not been implemented to ensure the safest and most appropriate methods to install new designs. Without written standards, faulty installations of solar batteries can increase risks to homeowners.

Recommendations:

Recommendation 1: We recommend that homeowners ensure their solar PV system complies with the current labelling standards.

A properly labelled system can help reduce the risk of electrocution. Awareness of the location of specific components can identify high voltage points. In addition, a properly labelled system can assist operational personnel during an emergency situation.

Recommendation 2: We recommend that homeowners perform a visual inspection of their solar PV system annually and monitor their solar PV system output monthly.

Proper maintenance of a solar PV system can reduce the probability of solar PV components causing a fire. Homeowners should visually inspect their systems for signs of deterioration and any build up of debris on or around the panels. Additionally, homeowners should schedule a professional inspection once every five years. Homeowners should also routinely check the Australian Consumer and Competition Commission's website or Clean Energy Council's website for product recalls on solar PV components. Products are recalled if they present an electrical safety hazard and therefore should be replaced to reduce fire risk.

Recommendation 3: We recommend that the ATA educate members and homeowners on best safety practices pertaining to solar PV systems via informational documents and/or videos.

Solar PV system designs are continuously updated with innovative features. By producing informational media, ATA can educate homeowners about new technology and can help mitigate the any additional risks. Additionally, keeping homeowners up to date on

current legislation and how homeowners can comply with the most recent standards can play a key role in mitigating risk for both the homeowner and emergency services in the event of an emergency. This proactive approach to safety will lead to fewer problems going forward with the industry.

Recommendation 4: We recommend that safety and installation standards be developed for storage battery systems.

Currently, there is a lack of installation standards for storage battery systems in Australia. The Clean Energy Council (CEC) has recently released installer guidelines for grid-connected energy systems with battery storage (CEC, 2016). However implementation of safety and install standards have not been mandated for installers. The CEC should also create a training program and accreditation process, specific to storage battery systems, for solar PV system installers.

Recommendation 5: We recommend that a project be completed on proper disposal of solar PV panels and storage batteries.

Solar PV panels and batteries contain toxic materials. Proper disposal of used or damaged panels and storage batteries can be challenging. Methods to dispose of or recycle panels and storage batteries could be beneficial to the advancing solar PV industry.

Authorship

Section	Primary Author(s)	Primary Editor(s)
Abstract	Zachary Hood	Alessandra Chiamonte
Executive Summary	Zachary Hood, Austin Smith, & Alessandra Chiamonte	All
Acknowledgements	Austin Smith	Alessandra Chiamonte
1. Introduction	Alessandra Chiamonte	Austin Smith
2. Background	Alessandra Chiamonte, Zachary Hood, & Austin Smith	Zachary Hood
3. Methodology	Alessandra Chiamonte	Austin Smith
4. Results & Discussion	Alessandra Chiamonte, Zachary Hood, & Austin Smith	Zachary Hood
5. Conclusion & Recommendations	Alessandra Chiamonte, Zachary Hood, & Austin Smith	Alessandra Chiamonte
References	All	Alessandra Chiamonte
Appendix A: Interview Consent Form	Alessandra Chiamonte	Zachary Hood
Appendix B: Interview Questions for Fire Services Personnel	Zachary Hood & Alessandra Chiamonte	Austin Smith
Appendix C: Survey Questions for Solar Installers	Zachary Hood & Austin Smith	Alessandra Chiamonte
Appendix D: Interview Questions for ACCC	Alessandra Chiamonte & Zachary Hood	Austin Smith
Appendix E: ATA Fact Sheet - Solar PV & Fire Risks	Alessandra Chiamonte, Zachary Hood & Austin Smith	All
Appendix F: ATA Fact Sheet - Battery Storage Systems	Alessandra Chiamonte, Zachary Hood & Austin Smith	All
Appendix G: ATA Fact Sheet - Support for Rooftop DC Isolator Mandate Removal	Alessandra Chiamonte	Zachary Hood & Austin Smith

Acknowledgements

We would like to recognise the following individuals and organisations for their assistance during the completion of our project in Melbourne, Australia.

- The Alternative Technology Association and its employees for creating a welcoming environment to work in.
- Mr. Damien Moyse, Mr. Andrew Reddaway, and Mr. Nick Carrazzo for their expertise, advice, resources, and assistance for our project.
- The Alternative Technology Association members for filling out our survey and sending personal emails to further expand our research.
- Dr. Jonathan Barnett for his continued support, knowledge, contacts, and collaboration with the ATA to formulate this project.
- The Worcester Fire Department and National Fire Protection Association for participating in discussions about our project while in the United States. Gaining insight on the subject matter with these two respected organisations helped to establish a basis of information.
- The Country Fire Authority, Fire & Rescue New South Wales, and the Metropolitan Fire & Emergency Service Board for allowing us to converse with them and provide us with supplemental material from other fire services.
- Mr. Rob Llewellyn, Mr. Greg Taylor, and the Australasian Fire and Emergency Service Authorities Council for providing data on solar related fires from fire services throughout Australia.
- Professors Holly Ault and Professor James Hanlan for their dedication, guidance, and advice in helping us to complete our project. Their constant feedback greatly increased the quality of our work in helping to produce a well-constructed report.
- Professor Chiarelli for preparatory guidance during ID 2050 before completing this project abroad.
- Lastly we would like to acknowledge Worcester Polytechnic Institute, for giving us the outstanding opportunity to complete an off-campus project and gain valuable experience.

Table of Contents

Abstract	i
Executive Summary	ii
Authorship.....	vi
Acknowledgements.....	vii
List of Figures	x
List of Tables	x
List of Acronyms	xi
1. Introduction	1
2. Background.....	3
2.1 What is Solar Energy?	3
2.1.1 Solar Energy in Australia	3
2.2 Introduction to Solar Photovoltaic (PV) Systems.....	6
2.2.1 Types & Configurations of Solar PV Systems.....	7
2.2.2 Advantages of Installing Solar PV Panels	9
2.2.3 Disadvantages of Installing Solar PV Panels.....	9
2.2.4 Worldwide Status on Solar PV Systems	10
2.2.5 Australia's Current Status on Solar PV Systems.....	11
2.2.6 Storage Batteries	12
2.3 Australia's Safety Regulations for Solar PV Systems.....	13
2.3.1 Solar PV Standards	14
2.3.2 Rooftop DC Isolator Mandate.....	15
2.3.3 Lack of Mandate in Other Countries.....	17
2.4 Fire Risks Attributed to Solar PV Systems.....	17
2.5 Other Risks Associated with Solar PV System Fires.....	18
2.6 Testing & Research.....	22
2.7 Project Goals.....	24
3. Methodology	25
3.1 Identify Fire Risks Associated with Solar PV System Components	25
3.2 Research Current Safety Protocols Involving Solar PV Systems.....	26
3.3 Compile Standard Operational Procedures of Fire Services.....	27
3.4 Limitations	28
4. Results & Discussion	29
4.1 Solar-Related Fires & Causative Agents	29
4.1.1 Number of Solar-Related Fires	29
4.1.2 Causes of Solar-Related Fires	31
4.1.3 Rooftop DC Isolators	36
4.2 Storage Battery Industry	37
4.3 Legislation Regarding Solar PV Systems.....	39

4.3.1 Safety Regulations on Solar PV Systems.....	39
4.3.2 Feed-In Tariffs.....	40
4.4 Firefighting Standard Operational Procedures.....	41
4.4.1 Solar PV Installation Fire Assessment.....	41
4.4.2 Firefighters & Rooftop DC Isolator.....	43
4.4.3 Additional Risks of Solar PV Systems for Firefighters.....	44
5. Conclusion & Recommendations.....	47
5.1 Summary.....	47
5.2 Recommendations.....	48
5.2.1 Recommendations for Homeowners.....	48
5.2.2 Recommendations for ATA.....	52
5.2.3 Recommendations for Other Organisations.....	53
5.2.4 Recommendations for Future Projects.....	55
Appendix A: Interview Consent Form.....	62
Appendix B: Interview Questions for Fire Services Personnel.....	63
Appendix C: Survey Questions for Solar Installers.....	64
Appendix D: Interview Questions for ACCC.....	69
Appendix E: ATA Fact Sheet - Solar PV & Fire Risks.....	70
Appendix F: ATA Fact Sheet - Battery Storage Systems.....	74
Appendix G: ATA Fact Sheet - Support for Rooftop DC Isolator Mandate Removal.....	76

List of Figures

Figure 1: Average Hours of Sunlight Daily During Worst Month of the Year	3
Figure 3: Number of Solar Installations & Installers.....	5
Figure 4: Photoelectric Effect of Semiconductors	6
Figure 5: Configuration of PV systems	8
Figure 7: Solar PV Installation (MW) and Price (\$/watt) in United States	10
Figure 8: Global Annual Solar PV Installations from 2000-2013 (MW)	11
Figure 9: Australian PV Installations Increase in kW	12
Figure 10: Required Solar System Labels	15
Figure 11: Solar PV System Configuration and Rooftop DC Isolator.....	16
Figure 12: DC Danger Zone	19
Figure 13: Spread of Fire Test Underneath Solar Panels.....	20
Figure 14: Roof Collapse Cause by Solar PV System Fire	21
Figure 15: Build Up of Debris Under Solar PV Panel.....	22
Figure 16: Underwriters Laboratories Tarp Experiment	23
Figure 17: Firefighters Applying Foam to Solar PV Panels	24
Figure 18: Solar-Related Fires in Australia from 2009-2015	30
Figure 19: Solar-Related Fires in NSW from 2011-2015	31
Figure 22: Causes of Solar-Related Fires in NSW	34
Figure 23: Causes of Solar-Related Fires Known By Installers	35
Figure 24: Effectiveness and Benefit of Rooftop DC Isolator Responses.....	36
Figure 25: Risk of Rooftop DC Isolator Results.....	37

List of Tables

Table 1: Summary of Standard Operational Procedures.....	43
--	----

List of Acronyms

AC: Alternating Current

ACCC: Australian Competition and Consumer Commission

AFAC: Australian Fire and Emergency Services Authority Council

AGM: Absorbed Glass Mat

APAC: Asia-Pacific

AS/NZS: Australian New Zealand Standards

ASTM: American Society for Testing Materials International

ATA: Alternative Technology Association

BFD: Boston Fire Department, USA

CEC: Clean Energy Council

CFA: Country Fire Authority, Victoria

DC: Direct Current

DFES: Department of Fire & Emergency Services, Western Australia

eAIRS: electronic Australian Incident Reporting System

EFI: Earth Fault Interrupter

FRNSW: Fire & Rescue New South Wales

kW: Kilowatt

MFB: Metropolitan Fire and Emergency Service Board, Victoria

MFS: Metropolitan Fire Services, South Australia

MW: MegaWatt

NFPA: National Fire Protection Association, USA

NSW: New South Wales, Australia

PJ: PetaJoules

PV: Photovoltaic

QLD: Queensland, Australia

SA: South Australia

SOPs: Standard Operational Procedures

SPD: Surge Protection Devices

TAS: Tasmania, Australia

UL: Underwriter Laboratories

UPS: Uninterrupted Power Supplies

V: Volts

VIC: Victoria, Australia

VRFB: Vanadium Redox Flow Battery

WA: Western Australia

WFD: Worcester Fire Department, USA

1. Introduction

Australia is exposed to the highest total solar radiation of any country in the world (Carson, Bradshaw, Jacques, Che, & Ball, 2010). This provides Australia with a high potential to utilise and develop renewable energies, specifically in the solar energy industry. Emerging technologies in solar photovoltaic (PV) systems allow consumers to harness solar radiation to convert the radiation into usable power. Australia has become one of the world leaders in solar PV systems with over 1.5 million installations across the continent (CEC, 2015b). The solar industry continues to grow exponentially with approximately one in every ten residential houses choosing to invest in solar energy (Mercer, 2014).

Government incentives for solar PV installations, in addition to cheaper production costs of module panels, have produced a growth in the number of low-cost manufacturers. Recently, there has been an increase in the number of solar-related fires in Australia, possibly linked to faulty systems. As of November 2014, there have been more than 167 solar-related fires in Queensland alone. Out of 1.4 million solar installations in Germany, only 120 solar-related fires have been reported over the past 20 years (Wirth, 2015). The United States National Fire Incident Reporting System has only recorded 44 incidents that involve solar PV systems (Grant, 2014). To reduce fire risks associated with solar PV systems, the Australian government and other organisations such as the Clean Energy Council and Australian Competition and Consumer Commission have produced safety standards. These safety guidelines include regulations for the installation process, electrical wiring standards, and replacement of faulty components.

The Alternative Technology Association (ATA) is a not-for-profit organisation that encourages individuals to live sustainably in their homes and communities. The ATA focuses on cost-effective sustainable resources to support Australia's renewable energy initiative (Backstrom & Dini, 2011). Additionally, this organisation values informing the public on updated governmental policies and current advances in alternative technologies through the distribution of monthly magazines, pamphlets and reports. The ATA has recently sought to understand the fire safety risks associated with solar PV system installations for homeowners (Alternative Technology Association, 2015).

The Alternative Technology Association will be able to distribute the findings of this study to its members to further increase homeowner awareness of the current solar PV system

risks, including an overview of advancements in the solar industry and the potential consequences of installing solar PV systems. Proactive steps, such as visual inspections and monitoring system output, can mitigate risks associated with solar PV systems.

2. Background

This chapter focuses on general aspects of the solar energy industry, including information on solar PV systems and its components. In addition, the background chapter discusses current standards utilised as safety guidelines for solar PV installations in Australia. Increased growth in the solar industry has raised concerns for homeowners with regards to increased outbreaks of solar-related fires. Fire risks of solar PV installations were assessed to highlight potential causes of solar-related fires. Assessment of fire risks will be utilised to raise homeowner awareness of potential safety concerns related to solar PV installations.

2.1 What is Solar Energy?

Solar energy is the production of energy by harvesting radiation from the sun. Two main types of panels can capture solar radiation: solar photovoltaic panels and solar thermal panels. Solar photovoltaic systems convert solar radiation to electricity by harvesting energy from photons of light. Solar thermal panels can produce a significant amount of heat through heat exchange (Carson et al., 2010). Both types of systems are typically mounted on the rooftops of both residential and commercial buildings.

2.1.1 Solar Energy in Australia

Australia and Africa have the highest average solar radiation in comparison to the other five continents. As shown in Figure 1, over half the continent of Australia receives on average five to seven hours of sunlight daily during the worst month of the year.

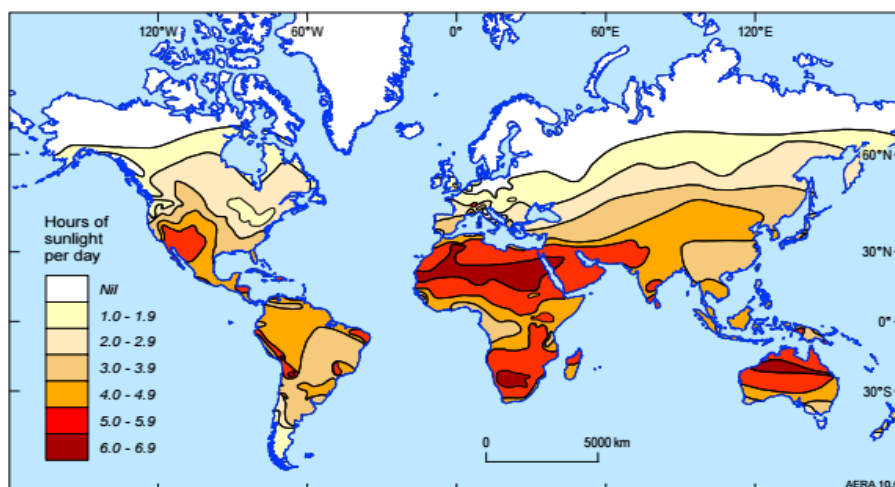

Figure 1: Average Hours of Sunlight Daily During Worst Month of the Year (Carson et al., 2010)

Australia has a high potential to adopt solar energy as its main source of power generation. In 2009, a study reported that approximately 60 million petajoules of electrical power could be generated annually from the solar radiation that penetrates Australia's surface (Carson et al., 2010). Figure 2 illustrates the average hours of sunlight the continent of Australia receives annually. Approximately half the continent can produce an average of 22-24 megaJoules of electricity per day. Although the amount of solar radiation that penetrates the atmosphere varies depending on the season and weather, Australia has the highest potential in the world for solar energy due to the tilt of the Earth's axis and average hours of daily sunlight (Carson et al., 2010).

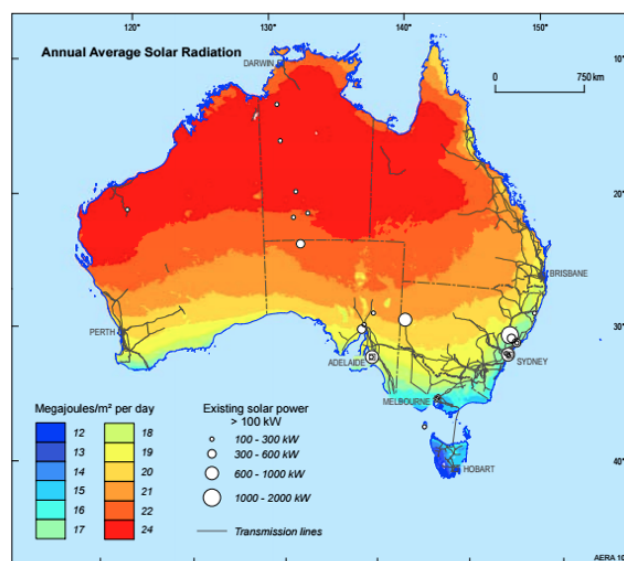

Figure 2: Annual Average Solar Radiation (Carson et al., 2010)

One drawback for Australia's potential for solar energy is due to the vast barren territories in the northwest regions of the continent that receive the highest solar radiation. A majority of these regions, specifically Northern Territory and Western Australia, remain untapped due to the low population densities in these areas. Connections to the grid system have also proven to be an issue. However, the solar radiation received in northern Queensland generates a substantial amount of power (Carson et al., 2010).

In 2000, the Renewable Energy (Electricity) Act commenced the issuing of governmental incentive programs to encourage renewable power generation and reduce the cost of installing renewable energy sources (Australian Government, 2000). Governmental rebates are granted to consumers only when the solar PV installation is performed by a Clean

Energy Council (CEC) accredited installer (CEC, 2015a). Since 1993, that accreditation process is continually updated to decrease the probability of inadequate solar installations that can increase fire safety risks of the system (CEC, 2014a). The CEC requires that solar installers must receive solar installation accreditations by participating in a series of registered training programs, providing electrical licensing credentials, and submitting a case study from an installation for review by a technical expert (CEC, 2014a). Solar accreditation must be renewed every two years and additional programs are offered through the CEC to keep solar installers updated on new advancements in the solar industry (CEC, 2014a).

As a result of the governmental incentives and the decrease initial costs of the solar PV systems, the number of solar PV systems increased significantly from 2008 to 2014. Figure 3 illustrates the annual increases in the number of both solar PV system installations and accredited solar PV system installers (SolarBusinessServices, 2014). The number of solar installations steeply increased each year from 2008 reaching an apex of over 300,000 solar installations in 2011. As shown in Figure 3, the number of annual solar installations has steadily decreased following the peak in 2011. However, the number of solar PV system accredited installers has plateaued at 4,500 installers from 2012 to 2014.

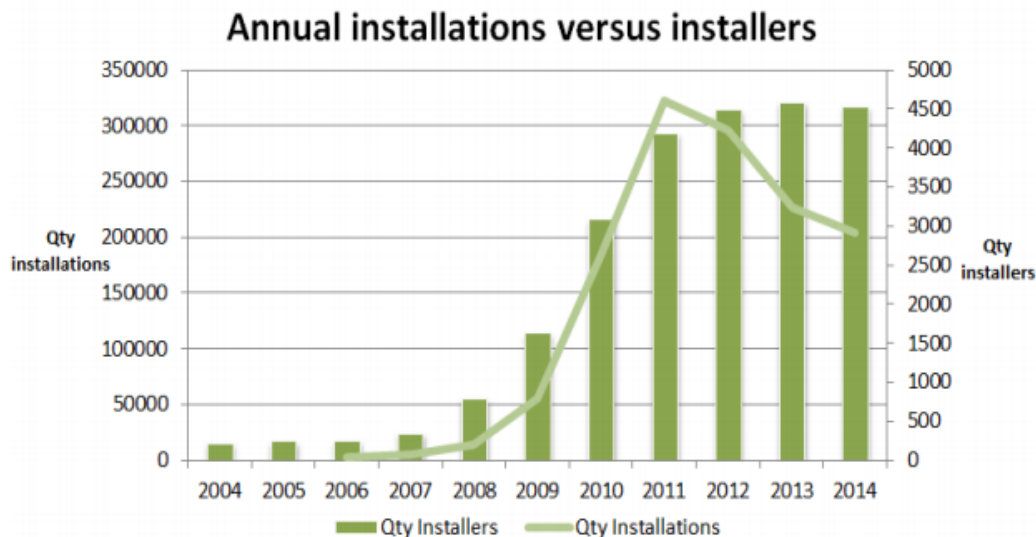

Figure 3: Number of Solar Installations & Installers (SolarBusinessService, 2014)

2.2 Introduction to Solar Photovoltaic (PV) Systems

Solar photovoltaic (PV) systems are capable of converting solar radiation directly into electricity through the photoelectric effect of semiconductors as illustrated in Figure 4. The photovoltaic effect occurs when a photon of light hits the surface of a silicon semiconductor doped with phosphorous and boron. The photons striking the surface excite the phosphorous and boron electrons. The excited electrons travel in the form of electricity towards a device in need of power, which drains the excited electrons down to a lower energy state. In this closed circuited system, the electron is returned to the semiconductor at the p/n junction to be recharged (Brooks et al., 2010).

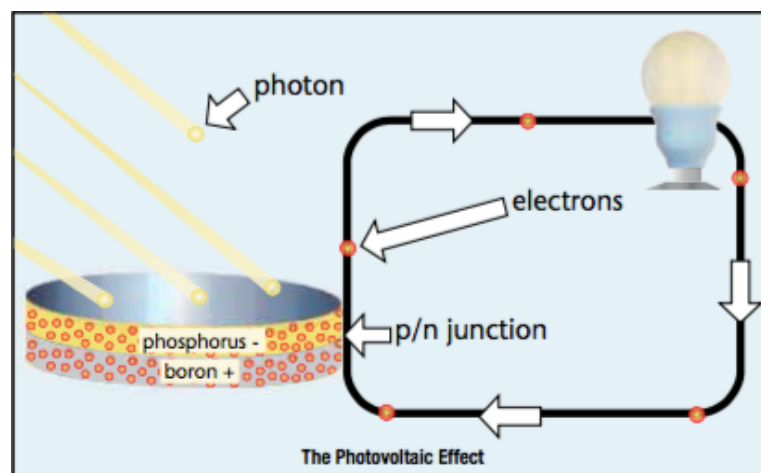

Figure 4: Photoelectric Effect of Semiconductors (Brooks et al., 2010)

PV systems are made up of panels that contain many cells performing the photoelectric effect. Each cell produces a small voltage output; however, when multiple cells are combined, higher sustainable voltages can be achieved. The voltage output produced is in the form of direct current (DC), which can be converted into alternating current (AC) by means of an inverter, thus delivering the form of electricity used inside buildings (Brooks et al., 2010). Voltage output is directly proportional to the amount of solar radiation captured by the solar PV cells (Stapleton, Neill, & Milne, 2013). However, some energy is dissipated as heat from the conversion of the voltage output into usable forms of energy (Stapleton et al., 2013).

2.2.1 Types & Configurations of Solar PV Systems

Consumers typically install panels on the roofs of residential or commercial buildings to optimise the solar radiation hitting the PV system. Although not as common, ground systems exist as well, especially in the form of “solar farms” made of up to hundreds of panels across an open piece of land such as a desert or field that receives a high concentration of solar radiation (Wilson & Laurent, 2014).

There are two main types of PV systems. Grid-dependent systems produce electricity to meet the needs of the consumer as well as feed any excess electricity back into the grid for use in other locations. This allows consumers to sell the extra electricity produced by their systems. When the PV system cannot meet household demands (e.g. at night, on cloudy days), power is pulled from the grid. A majority of solar PV systems installed are grid-dependent (Wilson & Laurent, 2014). A stand-alone system is entirely disconnected from the grid; the structure is completely reliant on the solar PV system and an on-site battery for all of its electrical needs. Any electricity not being used is stored in the battery, which provides electricity when the PV panels are not active (Wilson & Laurent, 2014). Arrays of batteries are located in close proximity to stand-alone solar PV system to optimise the voltage output of the module system (Stapleton et al., 2013).

A standard PV system is setup in the configuration of a series-parallel circuit. The connection of two or more panels to each other (in series) creates a string and two or more strings (in parallel) form an array. The combination of series-parallel provides an increased voltage (series) as well as an increased amperage (parallel). Figure 5 shows the configuration of a simple PV array labelled with the proper terminology for each component of the system. Residential systems are able to produce close to 600 volts DC through an advanced configuration of multiple strings and arrays (Wilson & Laurent, 2014).

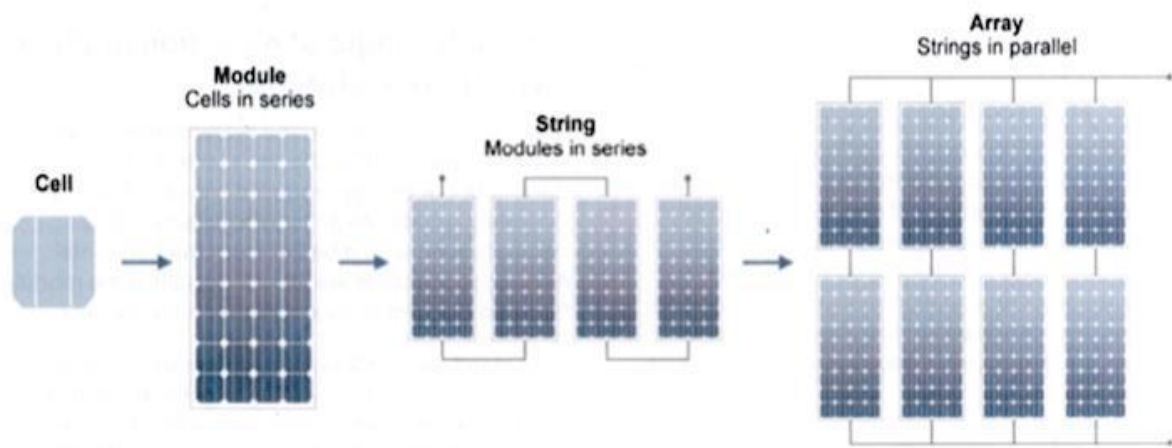

Figure 5: Configuration of PV systems (Stapleton et al., 2013)

A typical solar PV system is made of four main parts: the panel configuration, DC disconnect isolator, inverter, and AC disconnect isolator. Figure 6 displays a block diagram of the basic solar PV system setup.

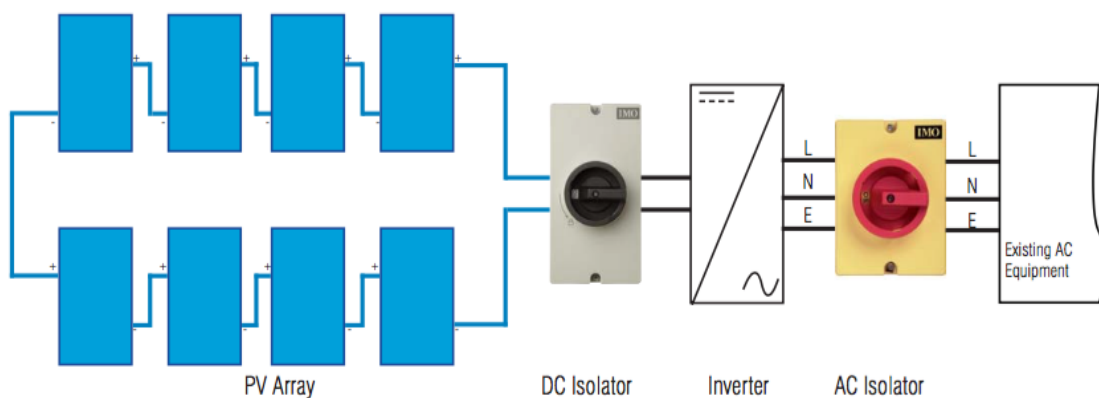

Figure 6: Block Diagram of Solar PV System (IMO, 2014)

The DC isolator is used to cut off the current flowing through the system and isolate the load voltage created by the solar panels before reaching the inverter. The inverter monitors the output of the solar system providing feedback on energy production and is equipped with an anti-islanding feature. Anti-islanding protection occurs when there is a short in the solar PV system or a blackout from the electric grid. The anti-islanding equipment isolates any voltage produced by the solar panels to prevent an overload to the main switchboard. An AC isolator performs the same action as a DC isolator switch and is

located between the inverter and main switchboard of a building. Both AC and DC isolators are required for all solar PV systems.

2.2.2 Advantages of Installing Solar PV Panels

Installation of solar PV systems offers many benefits to consumers willing to invest in the solar technology. This technology provides a renewable energy option in the field of electrical generation. Solar energy is readily available natural resource that cuts down on fumes emitted from burning fossil fuels such as coal and gas, and thus leads to a reduction in negative environmental impacts (Carson et al., 2010). Solar energy cannot be depleted and remains a constant source of available electrical energy. The solar energy industry has become a competitive industry in moving towards zero greenhouse gas emissions (Stapleton, Neill, & Milne, 2013). With respect to the consumer, solar PV systems provide an opportunity to save money through self-supplying electricity with the possibility to sell excess electricity production back to the grid. A worldwide increase in solar energy production has stimulated current advancements in solar technology to produce more efficient systems and cost reductions (Wilson & Laurent, 2014). Although a high initial investment, solar PV systems provide long-term sustainability with a lifespan in the range of 20 - 25 years with minimal maintenance (Grant, 2013).

2.2.3 Disadvantages of Installing Solar PV Panels

Although the solar industry has been advantageous in some aspects, there are some disadvantages to solar PV systems. Prices for systems have dropped over the years, but for the typical middle class family, these systems are still expensive. In addition, it takes a large amount of time to see return on the initial investment cost. A report produced by the Alternative Technology Association (ATA) shows that the payback period to cover initial cost can range from 6 to 20 years depending on household type, location, type of system, etc. (Reddaway & Moyse, 2015). Little to no production of electricity occurs during evening hours or under certain weather conditions, which decreases the efficiency of solar PV panels. Winter months and cloudy days decrease the effectiveness of solar PV panels due to the lack of sunlight. For the best efficiency and production, solar PV panels need to be placed directly in areas of unobstructed sunlight. Since the sun moves throughout the day, production of

electricity is not optimised for the duration of all daylight hours and potential electrical production can be lost. Additionally, solar PV panels are comprised of toxic metals such as silicon, mercury, lead, and cadmium, which need to be disposed of properly if panels become damaged (Kukreja, 2016).

2.2.4 Worldwide Status on Solar PV Systems

With the advancements of solar technology, solar energy has become popular in many countries including the United States, Germany, and Australia. The recent appeal of solar energy for homeowners and businesses correlates to the price drop of solar PV systems and the ability to save money by generating one’s own electricity. This has led to a rise in solar PV systems installed throughout the world. In the United States, prices for solar PV systems have dropped by a factor of three since 2005 as seen in Figure 6 (Solar Energy Industries Association, 2015). The cumulative total capacity of solar PV installations in MW since 2010 to 2014 has increased approximately six fold. Growth will continue into 2016 as another 20,000 MW of solar PV capacity are expected to be installed throughout the country, doubling the existing capacity (Solar Energy Industries Association, 2015).

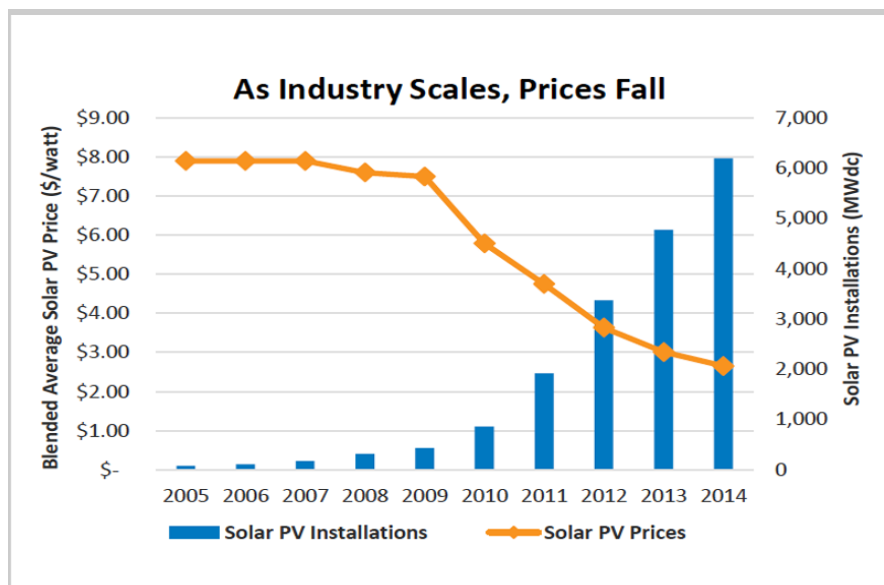
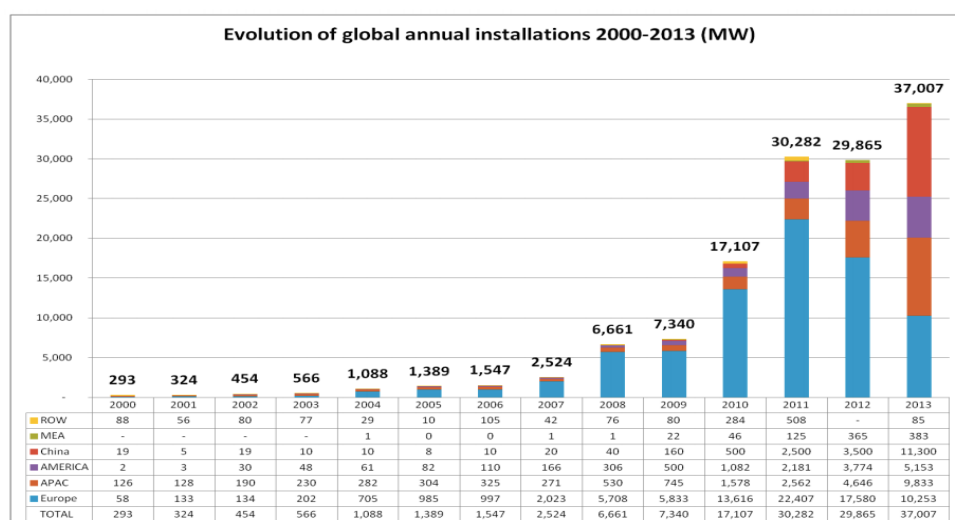

Figure 7: Solar PV Installation (MW) and Price (\$/watt) in United States
(Solar Energy Industries Association, 2015)

As shown in Figure 8, the number of solar PV installations has increased dramatically throughout the world. Installations have been increasing in Europe, China, Asia-Pacific (APAC), and the United States. Germany has over 1.4 million solar installations and the most installed PV capacity in the world (International Energy Agency, 2015). Germany's installed PV capacity stands at a total of 38.2 GW and China ranks second at 28.1 GW as of 2014 (International Energy Agency, 2015).



Source: EPIA

Figure 8: Global Annual Solar PV Installations from 2000-2013 (MW) (Shahan, 2014)

2.2.5 Australia's Current Status on Solar PV Systems

Australia has become an emerging leader in solar technology with over 1.5 million solar PV systems installed across the continent as of 2015. This is a dramatic increase from the 100,000 systems installed as of 2010 (CEC, 2015b). Figure 9 describes the increase of solar technology in total kiloWatt (kW) capacity of the PV systems installed. From October of 2010 the reported kW capacity of PV systems has increased by over 1000% from 400,000 kW to almost 5 million kW in October of 2015, producing approximately 20 million kiloWatt-hours in 2015. (Australian Renewable Energy Agency, 2015). It is projected that the annual solar energy use in Australia will continue to increase to 24 PetaJoules (PJ), which is equivalent to over 6.6 trillion kiloWatt-hours, by 2030 (Carson et al., 2010).

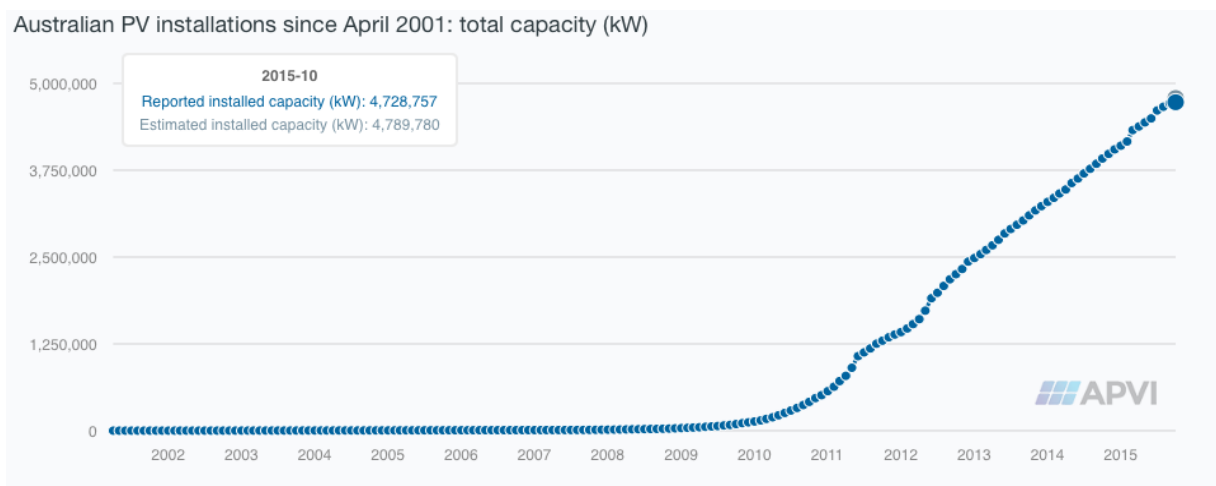

Figure 9: Australian PV Installations Increase in kW (Australian Renewable Energy Agency, 2015)

2.2.6 Storage Batteries

Worldwide growth in the solar energy industry has led to the development of alternative technologies and new designs to further improve the efficiency of solar PV systems in the past decade. One category of solar technology that is currently advancing is the battery component in stand-alone PV systems for electrical storage. Current battery designs in use for solar PV systems include lead acid batteries, lithium ion batteries, and flow batteries (Zipp, 2015).

Lead acid batteries are currently the most common batteries for solar energy storage. The absorbed glass mat (AGM) deep-cycle designs have increased the overall performance and total energy output of lead acid batteries (Zipp, 2015). The recombinant AGM batteries are able to convert hydrogen and oxygen into water, which leads to no additional maintenance for the system (Zipp, 2015). Older designs of lead acid batteries required the battery components to be refilled because the electrolyte necessary to submerge the electrodes evaporates while the battery charges. Additionally, the battery enclosure for old lead acid batteries needed ventilation to avoid the build up of hydrogen gas (Zipp, 2015). Benefits of the lead acid battery technology include relative low cost and low maintenance. Additionally, the overall design of lead acid batteries is better understood than newer battery technologies.

Lithium ion batteries are currently making a push into the solar energy battery storage market. Lithium ion batteries are designed similarly to lead acid batteries in that they possess

positive/negative electrodes surrounded by electrolyte, but the electrolyte in lithium ion batteries is solid rather than liquid electrolyte in lead acid batteries (Morris, 2014). Different chemical structures of lithium ion batteries are used for different applications (Morris, 2014). Compared to lead acid batteries, lithium ion batteries deliver more cycles during their lifespan and have higher charge/discharge efficiencies (Zipp, 2015). When idle, lithium ion batteries lose little of their original capacity, which is beneficial for the periodic usage of energy for solar applications (Zipp, 2015). Lithium ion batteries are also lighter in weight compared to lead acid batteries, which facilitates installation. In addition, continued maintenance and refills of lithium ion battery components is not necessary (Zipp, 2015).

Flow batteries are starting to develop as an alternative battery option to lithium ion and lead acid batteries for solar energy applications. Rather than storing energy in electrodes like lead acid and lithium ion batteries, flow batteries store energy in liquid electrolytes (Smith, 2016). Two types of flow batteries on the market currently are the Z-cell flow battery and the vanadium redox flow battery (VRFB). The Z-cell flow battery is an Australian product aimed at competing with the lithium ion battery, one of the dominating solar energy storage batteries on the market. The Z-cell flow battery is specifically designed so users can discharge and charge the battery daily with minimal degradation (Smith, 2016). The VRFB battery technology is currently the most mature flow battery design (Zipp, 2015). VRFB manufacturers obtain the chemical component vanadium from fly ash (a by-product of coal burning electrical plants), mining slag, oil field sludge, and other forms of environmental waste (Solar Choice, 2015). The production of these batteries from coal plant waste products can lead to a decrease in the price of VRFB batteries (Zipp, 2015). An advantage of the VRFB is that adding more electrolytes can increase the capacity of the battery and the vanadium electrolyte does not degrade over time (Zipp, 2015). Another major benefit for VRFB batteries is their ability to be charged and discharged without affecting their overall lifespan (Zipp, 2015).

2.3 Australia's Safety Regulations for Solar PV Systems

The recent increase in solar PV systems in Australia has led to the development and implementation of regulations regarding the installation and safety of solar PV panels. Standards Australia developed the standard *AS/NZS 5033: Installation and safety*

requirements for photovoltaic (PV) arrays 2012. The standards outline safety issues associated with solar PV panels and make recommendations for various solar system components to eliminate or reduce the risk of potential hazards. The potential hazards associated with solar PV panels include electric shock, overcurrent, earth faults, and overvoltage.

The Australasian Fire and Emergency Services Authority Council (AFAC) has produced guidelines to support and assist emergency agencies responding to and treating incidents involving solar PV systems (Considine, 2013). AFAC works directly with Standards Australia to create legislation relating to emergency services and land management.

2.3.1 Solar PV Standards

The *AS/NZS 5033* standard recommends, and in some cases requires, protection to combat against overcurrent, overvoltage, and earth faults. Overcurrent can occur due to short circuits in modules, junction boxes, combiner boxes, module wiring, or array wiring (Standards Australia, 2012). For a solar PV system, protection from overcurrent is to be provided when required by the manufacturers of PV modules and solar PV equipment (Standards Australia, 2012). Overcurrent protection is required for systems connected to external sources, such as batteries, to prevent more current feeding into the PV array under fault conditions (Standards Australia, 2012). Some examples of overcurrent protection devices include fuses and circuit breakers (Standards Australia, 2012).

Earth faults are faults in which inadvertent contact occurs between an energised conductor and ground or equipment (Littlefuse, 2015). Earth fault protection requirements for solar PV systems vary depending on the system. If a system is operating between 50V to 1000V AC or 120V to 1500V DC, then an earth fault interrupter (EFI) must be installed with the array (Standards Australia, 2012). The EFI can detect an earth fault, interrupt it, and indicate that a fault is occurring with an audible external alarm or light signalling when the current exceeds the set maximum (Standards Australia, 2012). Many inverters act as an earth fault indicator and display a light that indicates when an earth fault is detected (Standards Australia, 2012). If the solar PV system is operating below the voltage levels stated above, then an EFI is not required.

Overvoltage occurs when the voltage in a circuit is raised beyond its design limit, resulting in a voltage spike or a power surge that can cause damage to components in the system. The standard has a few requirements that can be used to provide protection against overvoltage: avoidance of wiring loops, installation of surge protection devices (SPD), and shielding of long cables (Standards Australia, 2012). Surge protection devices are specifically designed to limit overvoltages, mainly from lightning strikes, which is a concern for solar PV panels as they are exposed to the elements and have an increased chance of being struck by lightning.

The labelling of some components of solar PV systems, including panels, inverter, switchboard, and meter box, is required according to the standard. Most labels should be placed at the switchboard for all electricians and emergency services to see. Additional labelling should be placed on the appropriate device. Labels are shown in Figure 10 for DC voltages, notification of solar arrays on roof, and DC isolators.

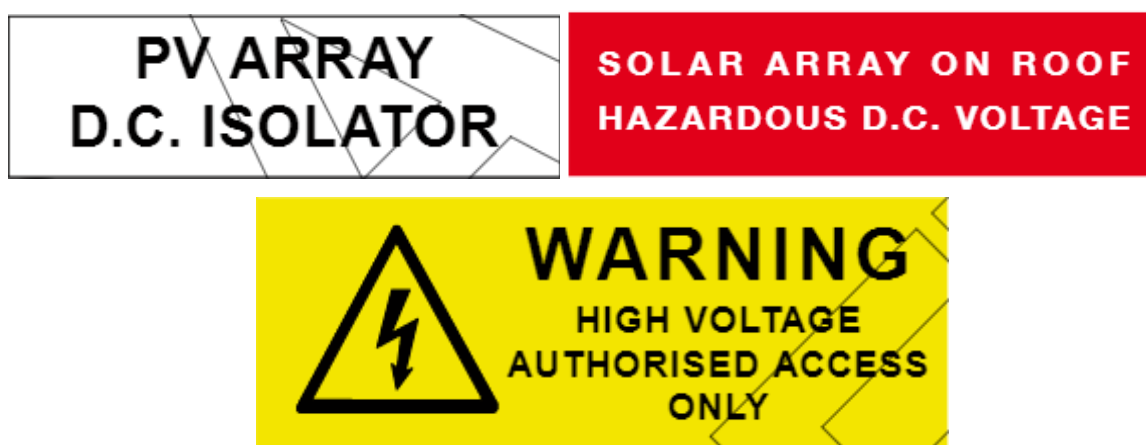

Figure 10: Required Solar System Labels (Standards Australia, 2012)

2.3.2 Rooftop DC Isolator Mandate

In 2012, the Australian government mandated the installation of DC isolators on rooftops of solar PV systems. Australia is currently the only country in the world that requires rooftop DC isolators. Rooftop DC isolators were proposed by some emergency services as a way to shut down a solar PV system closer to the point of DC current generation (Holden, 2015). This isolation switch would provide firefighters with the option to shut off electrical current from the solar panels supplied to the building, provided that the firefighters

have rooftop access. Figure 11 shows the placement of a rooftop isolator attached to a solar PV array.



Figure 11: Solar PV System Configuration and Rooftop DC Isolator (Linked Group Services, 2016)

The Queensland Government Electrical Safety Office reported there have been 209 fires incidents involving solar isolation devices and of these, 187 were related to DC isolators (Holden, 2015). The Australian Competition and Consumer Commission (ACCC) governmental agency issued recalls on several rooftop DC isolator products in response to the failure of the products to comply with safety standards. The first recall for rooftop DC isolators occurred in 2012 due to defective mechanisms and overheating, leading to a potential fire hazard. In 2014, five different brands including 19 different models were recalled (ACCC, n.d.). One brand alone accounted for at least 3,700 installations in New South Wales (ACCC, 2014). According to recall publications produced by the ACCC, four out of five of these isolators were recalled due to faults that potentially led to an increased fire risk (ACCC, n.d.).

To decrease fire risk from weathering factors, some manufacturers of the device have started to build isolators inside a weather shield casing. Water ingress into the DC isolator unit causes the isolator to short, creating a fault within the system. Water ingress is one of the most common problems due to a heavy wet season in some regions of Australia. Additionally, some experimental tests have shown that the rooftop DC isolator unit cannot withstand the pressurised water from a fire hose (Sadler, 2015).

2.3.3 Lack of Mandate in Other Countries

Apart from Australia, Germany and the United States are two leading countries in solar energy. Both Germany and the United States do not mandate that solar PV systems be installed with a rooftop DC disconnect isolator. Germany, along with other European countries, requires DC isolators to be built-in with the inverter (Projoy Electric, 2015). This eliminates an extra connection that installers must make in the solar PV system resulting in fewer failure points in the system.

The United States has never required the addition of a rooftop DC isolator to solar PV systems. Instead, disconnect switches are required for purpose of isolation with any electrical equipment that is connect to a building's electrical circuitry (Grant, 2013). The location of PV disconnecting devices should be installed at a readily accessible location either on the outside of a building or inside nearest the point of system components (NFPA 70, 2014). There have been very few incidents of fires originating from solar PV systems, however a few reports of specific events are able to give a good understanding of fires involving solar PV systems (Grant, 2013). Additionally, alternate methods of turning off the power source from the solar PV systems to the building have been investigated in the United States, especially in California (Backstrom & Dini, 2011).

2.4 Fire Risks Attributed to Solar PV Systems

Advancements in rooftop solar technology have been beneficial for power generation; however, these new technologies have raised concerns for homeowners. Solar panels are often viewed as potential hazards for firefighters (Backstrom & Dini, 2011). As the number of solar PV systems in Australia increases, the potential for the occurrence of solar-related fires also increases. The presence of solar PV systems on rooftops has been proposed to increase the probability of a building fire due to problems with electrical wiring and components necessary to install a solar PV system. In addition, the presence of a solar PV system may increase the severity of a fire regardless of its source.

The most likely cause of solar-related fires is due to electrical component failures associated with solar PV installations. For a solar PV system, additional electrical wiring components must be routed from the rooftop through the house to the inverter (Standards Australia, 2012). Although installations comply with the Australian standards, the exposed

wiring increases the probability of a fire (Standards Australia, 2012). Exposure of the electrical wiring to extreme weather conditions can cause the casing of the wiring to deteriorate. The frayed wiring can result in an exposed live current that could start a fire. The exposure of the solar PV installations to weather conditions is another potential cause of solar-related fires due to water ingress in the electrical components of the system. Moisture can affect electrical components and cause a short circuit in the solar PV system, thus causing a fire. To combat these problems, the standards recommends that wherever, possible, cables for solar PV systems should be guarded by double or reinforced insulation (Standards Australia, 2012).

2.5 Other Risks Associated with Solar PV System Fires

The presence of rooftop solar PV installations poses additional safety concerns for homeowners and individuals that work with solar PV systems, such as firefighters and solar installers. The primary danger associated with solar PV systems is electrical shock. Rooftop PV systems convert solar radiation to electricity, and are always energised under conditions with natural light. However, bright artificial light can produce a low voltage electrical current from the solar panels under darker conditions. Photovoltaic systems have been recorded to generate approximately 600 volts DC, which is lethal to anyone who accidentally comes into contact with the exposed metal of PV panels or exposed wiring of the system, including firefighters (Brooks et al., 2010).

During a house fire, the risks associated with solar PV systems increases. If the solar PV system is on fire and firefighters are attempting to extinguish the fire with a hose stream of water, the energised panels can electrify the stream of water (Backstrom & Dini, 2011). This can result in firefighters possibly being electrocuted. To avoid this risk, firefighters can apply the stream of water at a safe distance of 20 feet or more (Backstrom & Dini, 2011).

Electrical wiring routed inside a home carries an uninterrupted flow of DC current from the solar PV panels to the inverter. This is known as the DC danger zone (Figure 12), an area in which the potential risk for electric shock and fire is increased. Presently, no device can be used to detect DC current, which poses an increased risk for homeowners and firefighters during a fire incident. Unlike AC current, DC current does not generate a detectable magnetic field that can be monitored. Therefore, conductive surfaces can carry

high electrical voltages that can be dangerous to unknowing homeowners or firefighters. Ted Spooner, chair of the Australian Standards committee responsible for PV systems, produced a report in 2011 outlining the risk and suggested procedures for shutting down solar systems and increasing firefighter safety (Spooner, 2011).

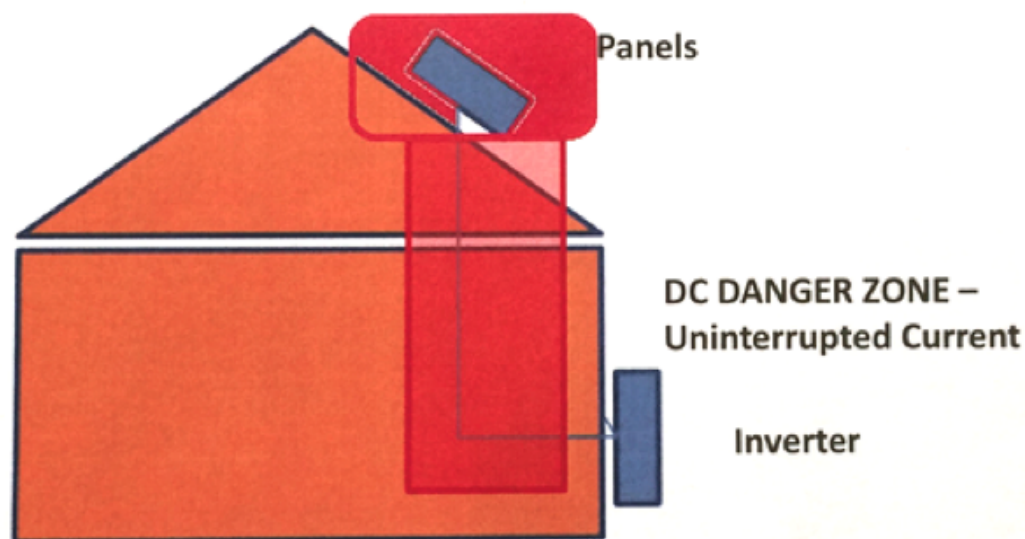

Figure 12: DC Danger Zone (Foran & Williams, n.d.)

Another safety concern for homeowners and firefighters during a house fire is the hazardous toxins that are released when a solar photovoltaic panel catches on fire. Solar PV panels are made of materials such as silicon, phosphorous, arsenic and concentrated metals. During solar panel production, a protective aluminium casing covers the materials. However, aluminium melts easily when exposed to the high temperatures of a fire. This allows the contents to escape into the air surrounding the fire. Inhalation of these chemicals can be dangerous to individuals not wearing protective breathing masks (Brooks et al., 2010).

Storage battery systems have also proven to be dangerous specifically for firefighters coming into contact with solar PV systems. Most solar PV off-grid systems rely on batteries for electrical power storage in areas where power outages are frequent. Battery systems are either lead acid or lithium based, which are dangerous for two reasons. First, toxins released by chemicals stored in the battery are dangerous when inhaled and, secondly, gases emitted from these batteries are highly flammable. In the event of a fire involving a solar PV system

with a battery storage component, released toxins from the batteries could potentially fuel the fire, which could prove to be problematic for firefighters attending the scene (Brooks et al., 2010). As technological advancements are made in solar photovoltaic systems, authorities like the Fire Protection Research Foundation have implemented training programs to assist firefighters in avoiding these hazards (Backstrom & Dini, 2011).

Solar PV installations can increase the intensity of fires through the “channelling effect”, the build up of debris, or the combustibility of rooftop materials. A majority of photovoltaic systems are mounted rooftop panels. For the installation of these panels, a gap is often left between the roof and the back of the solar panel. Recent studies have found that the gap between the panels facilitates the spread of fire across the roof surface (Sherwood et al., 2013). Solar photovoltaic systems present a hazard when fire becomes trapped between the solar panels and the roof, as shown in Figure 13.



Figure 13: Spread of Fire Test Underneath Solar Panels (Sherwood et al., 2013)

Once fire is within the gap between the panels and the roof, the temperature within the gap increases from the confined flames. Solar panel gaps do not allow the fire to dissipate outside of the area. The concentration of heat between the panels and the roof surface is known as the “channelling effect” (Sherwood et al., 2013). The “channelling effect”, coupled with the increased load placed on the roof from the solar panels, weakens the roof. This combination can lead to roof collapse, depending on the intensity of the fire (Figure 14).



Figure 14: Roof Collapse Cause by Solar PV System Fire (Shipp et al., 2013)

Biological debris can build up on or around solar PV panels as shown in Figure 15. In a research study, the accumulation of kindling and leaves on the roof next to the solar PV panels increases the probability of a fire (Wills, Milke, Royle, & Steranka, 2014). The build up of debris can increase the intensity of a fire and increase the spread of the fire across the entire roof (Wills et al., 2014). Solar PV panels themselves are not resistant to fires and are composed of combustible materials (Brooks et al., 2010). Recent studies in the United States have shown that roofing materials contribute to the spread of the fire (Wills et al., 2014).



Figure 15: Build Up of Debris Under Solar PV Panel (AGL, n.d.)

2.6 Testing & Research

Due to the increase in solar PV system installations across the world, firefighters have increasingly encountered buildings with solar panels on the roof in the event of a fire. Solar PV panels present a major hazard to firefighters. Even if power is cut off to a building, the PV panels continue to generate electricity. This poses a major risk to firefighters in emergency situations because the wires from the solar PV panels to the inverter are live. Research has been done in the United States on different methods that firefighters can use to prevent illumination from striking solar panels.

The Underwriters Laboratories (UL), located in Illinois, has conducted research and experiments on methods related to handling solar PV system components. Various experiments have been carried out to find the optimal methods to disconnect or disrupt the electricity running through the solar PV panels in the case of a fire. These tests focused on blocking illumination that enters the solar PV panels to stop the electricity running through them, thereby eliminating or reducing the risk of electric shock for firefighters in the case of a fire.

The first type of testing dealt with tarps that covered the solar PV panels. These tarps varied in thickness, length, colour, cost, and some were approved by different standards organisations such as the National Fire Protection Association (NFPA) or UL (Backstrom &

Dini, 2011). Out of testing four tarps, two were approved and deemed safe to use while the other two, if used, would result in electrocution if a person came in contact with the panel whether the tarp was covering it or not (Backstrom & Dini, 2011). Figure 16 displays the two approved tarps from the experiment. The tarp on the left in Figure 14 was the cheapest out of all of the tarps used and the tarp on the right was the second most expensive tarp and also met the NFPA 701 standard. During most emergency situations, tarps are not utilised by the fire services (Backstrom & Dini, 2011).



Figure 16: Underwriters Laboratories Tarp Experiment (Backstrom & Dini, 2011)

Another experiment pertained to foam being applied on two different solar PV systems. The purpose of the experiment was to examine the foam's ability to block illumination entering the solar PV panel (Figure 17). The two different solar PV systems used had an open circuit voltage of 136 volts DC and 63 volts DC, respectively, and under the same experimental conditions, foam was applied to completely cover the panels (Backstrom & Dini, 2011). Two minutes after the foam application, the open circuit voltage decreased marginally. After an additional ten minutes, the foam had evaporated causing the solar PV systems to be measured at the original open circuit voltage. In Figure 17 the foam can be seen being applied to one of the solar PV systems. The experiments concluded that the foam was not reliable in blocking the illumination into a solar PV panel and that some tarps can be effective in these situations (Backstrom & Dini, 2011).



Figure 17: Firefighters Applying Foam to Solar PV Panels (Backstrom & Dini, 2011)

2.7 Project Goals

The goal of this project was to analyse the fire safety risks associated with solar PV system installations by interviewing several different personnel involved with these systems. To identify the fire risks, statistical data of solar-related fires from the eAIRS database was analysed. Accredited solar PV system installers were also surveyed to assess the current advancements in the solar industry and fire risks concerning solar PV system components. Standard operational procedures from the Australian fire services were obtained to evaluate the additional risks to firefighters when solar PV systems are present. As a result of our findings, a pamphlet was distributed through ATA to raise awareness of potential safety concerns and precautionary actions for homeowners who choose to invest in solar PV systems.

3. Methodology

The overarching goal of this project was to assess fire risks associated with solar PV system installations by gathering information from the Australian fire services personnel and the solar PV panel installers. The project sought to identify the causes of solar-related fires. To achieve our project goals, the team developed the following objectives:

1. Identify fire risks associated with solar PV system installations;
2. Research current fire safety standards involving solar PV systems;
3. Evaluate operational procedures from firefighters when encountering buildings with rooftop solar PV system installations.

3.1 Identify Fire Risks Associated with Solar PV System Components

The first objective was to investigate the various causes of solar-related fires. Possible ignition factors from solar PV panel components were accumulated through data collected by Australasian Fire and Emergency Services Authorities Council (AFAC) from their Fire Investigation Network, and by FRNSW from filed incident reports in the eAIRS database. These components included electrical wiring, isolators, inverters and the solar panel arrays. The goal for this objective was to identify the causes of recent fires resulting from solar PV systems throughout Australia.

Solar installers across Australia completed a survey questionnaire to gather opinions associated with solar PV systems and their components, including the rooftop DC isolator and battery storage systems. The CEC website was searched for a list of installers in Melbourne, Victoria and throughout other Australian states. In addition, the ATA compiled a list of accredited installers. ATA members were emailed to expand an original solar installer contact directory to accumulate a broader perspective of a proposed linkage between solar-related fires and solar components. Questions from the survey elicited opinions on the quality of products, preferred brands, benefits/risks of rooftop DC isolators, and the overall effectiveness of rooftop DC isolators. At the end of the survey installers were asked if they had any experience with storage battery installs and perspective on the future of the solar storage battery industry in Australia. The phone survey for installers can be found in Appendix C: Survey Questions for Solar Installers.

A total of 82 installers across Australia were contacted and 25 solar installer surveys were completed. Out of the 25 completed installer surveys, ATA members referred 18 of the installers who participated. The remaining seven completed surveys were completed by installers non-affiliated with the ATA. From the sample of 25 surveys a selection bias formed due to the lack of surveys completed by installers non-affiliated with the ATA. The results of the installer surveys were used to determine the reliability of the rooftop DC isolator switch and other additional risks associated with solar PV system components.

Data collected from AFAC's Fire Investigation Network and the solar installer surveys were analysed to determine if solar PV installations led to an increased fire risk for homeowners with these systems. After analysing the compiled data from various sources, a fact sheet was produced to inform homeowners of proactive steps to mitigate fire risks (Appendix E: Fact Sheet for Homeowners).

3.2 Research Current Safety Protocols Involving Solar PV Systems

In the United States, specific safety protocols were obtained from the National Fire Protection Association (NFPA) was contacted to gain a further understanding of standards required for electrical wiring and installations of solar PV systems in the United States. Contacts from the NFPA staff include a Division Manager, Electrical Engineer, and Fire Protection Engineer. In Australia, safety protocols regarding solar PV installations from the Australian standard *AS/NZS 5033: Installation and safety requirements for photovoltaic (PV) arrays 2012* were obtained.

Two members of the Hazard Analysis and Management division from the Australian Competition and Consumer Commission (ACCC) were contacted to understand safety concerns that determined product recalls on rooftop DC isolators in 2014. The ACCC is responsible for issuing product recalls due to electrical hazards and failure to comply with safety guidelines. The interviewees provided documentation for product recalls. Additional information was provided regarding the notification process for product recalls. Interview questions can be found in Appendix D: Interview Questions for ACCC.

3.3 Compile Standard Operational Procedures of Fire Services

For the third objective, informed sources from the Worcester Fire Department in the United States and several Australian fire services were interviewed to gather information regarding standard operational procedures (SOPs). Research was conducted to accumulate written procedures and training documentation that fire services utilise when encountering rooftop solar PV systems.

Informed sources from the Worcester local fire department were interviewed as a convenience sample to gain a basic understanding of firefighter practices. The District Chief of the Training Division and two Lieutenants provided first-hand information on the training programs for firefighters handling fires with solar PV systems. An understanding of operational procedures when firefighters encounter solar PV systems was gained from this interview. The compilation of these interviews is not indicative of the universal practices performed by firefighters across the United States.

After networking with ATA and AFAC, contacts in the Country Fire Authority (CFA) and Fire & Rescue New South Wales (FRNSW) were acquired. Additional information regarding CFA and FRNSW SOPs were obtained from documentation provided following the interviews with their respective representatives. The purpose of interviewing informed sources from within fire services was to gain their perspective on working with solar PV systems and their components; interview questions are shown in Appendix C: Interview Questions for Fire Services Personnel. The interview responses provided a general perspective of SOPs utilised by operational personnel. Interview questions pertained to the existence of fire services training programs specifically focused on fire safety with solar PV systems. Interviews with informed sources were anonymous as stated in the Appendix A: Interview Consent Form.

Several fire districts were contacted across Australia through our informed source in the CFA. Documentation from Metropolitan Fire Service South Australia (MFS) and the Department of Fire and Emergency Services Western Australia (DFES) was obtained. Documentation included SOPs and training programs for the respective fire services. The information gathered from all sources was compiled and assessed for similarities and/or differences between safety protocols based on location.

3.4 Limitations

Potential sources of errors were recognised that could potentially affect results. The first potential source of error is found in the statistics received from AFAC. The data were presented in aggregate form and incomplete. There is potential for missing data and not all agencies responsible for keeping the information requested have contributed to data received. Statistical evidence determined that as much as 75% of fires in residential homes are unattended by fire services and therefore, remain unreported (Barnett, Bruck & Jago, 2007). Additionally, the data are also only relevant for four out of the seven states in Australia. Therefore, conclusions on solar-related fires cannot represent Australia completely.

The second source of error comes from the bias of installers who completed the survey. Out of the 25 installer surveys completed, a majority of the installers had been recommended by the ATA staff or ATA members. In addition, more than half of the respondents primarily worked in the Victoria state of Australia.

A third potential source of error is potential bias from individual representatives of the Australian fire services. The results were obtained from a limited number of interviews and documents. In total, only informed sources from two different fire services were personally interviewed in Australia. Documentation on standard operational procedures was acquired for two additional fire services.

4. Results & Discussion

The recent increase of solar PV installations in Australia has led to safety concerns for homeowners and the Australian fire services regarding solar-related fires. This chapter discusses the possible ignition factors of solar-related fires, additional safety concerns that may arise from battery storage systems, and the standard operational procedures utilised by the Australian fire services. The combination of these findings contributed to the production of a fact sheet to raise public awareness of solar PV system safety issues and the operations fire services will perform during a fire.

4.1 Solar-Related Fires & Causative Agents

Findings on the number of solar-related fires and components linked to the causative agent of these fires were identified from three sources: survey responses from solar installers, database information gathered from the Australasian Fire and Emergency Service Authorities Council (AFAC) and interviews with representatives from Fire & Rescue New South Wales (FRNSW). AFAC's Fire Investigation Network provided statistics on solar-related fires from four states. Three key informants from FRNSW provided statistics on the number of solar-related fires from 2011 to 2015 in New South Wales (NSW) and the causes of these fires.

4.1.1 Number of Solar-Related Fires

Data containing solar-related statistics for four (NSW, QLD, VIC, WA) states were provided by AFAC's Fire Investigation network. Due to privacy restrictions, data were received in aggregate form. A total of 400 fires were recorded involving solar PV arrays and associated equipment between 2009 and 2015. A majority of these fires were reported in NSW (254). Figure 18 shows the number of fires each year by state from 2009-2015.

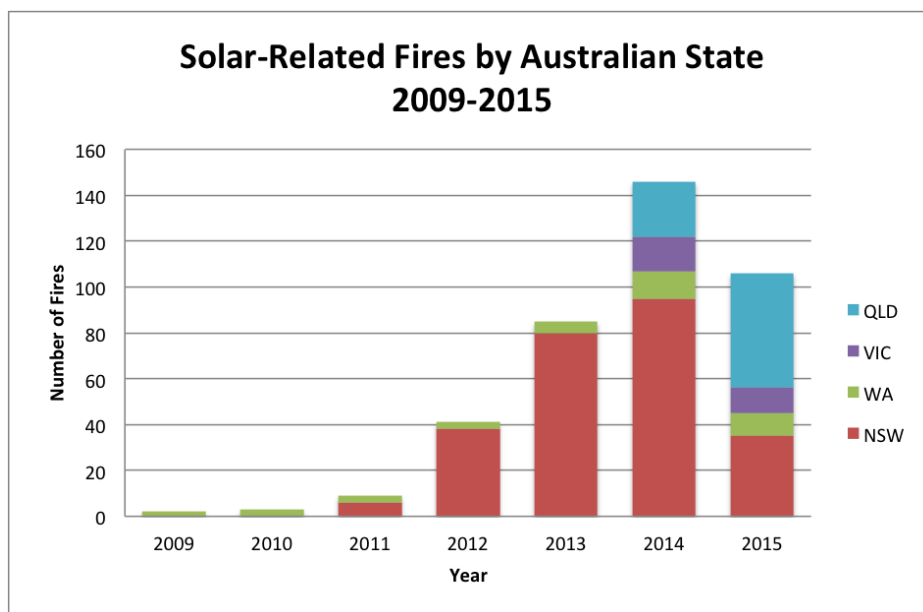

Figure 18: Solar-Related Fires in Australia from 2009-2015 (Data Source: AFAC)

Figure 18 shows a steady increase in the number of solar-related fires from 2009 to 2014. As shown in the data, the number of solar-related fires dropped from 146 in 2014 to 106 in 2015. Queensland was the only state that reported an increase in the number of recorded fires from 2014 to 2015.

Solar-related fire data were also obtained separately from FRNSW. The data retrieved from the electronic Australian Incident Reporting System (eAIRS) represents only fires to which FRNSW responded. FRNSW provides emergency services for metropolitan NSW and their data does not include solar-related fires from other regions in NSW. A total of 212 solar-related fires were reported between 2011 and 2015. Figure 19 again shows a steady increase in the number of solar-related fires reported by year, similar to AFAC's data in the number of solar-related fires. Both figures support that there was a decrease in the number of solar-related fires in 2015.

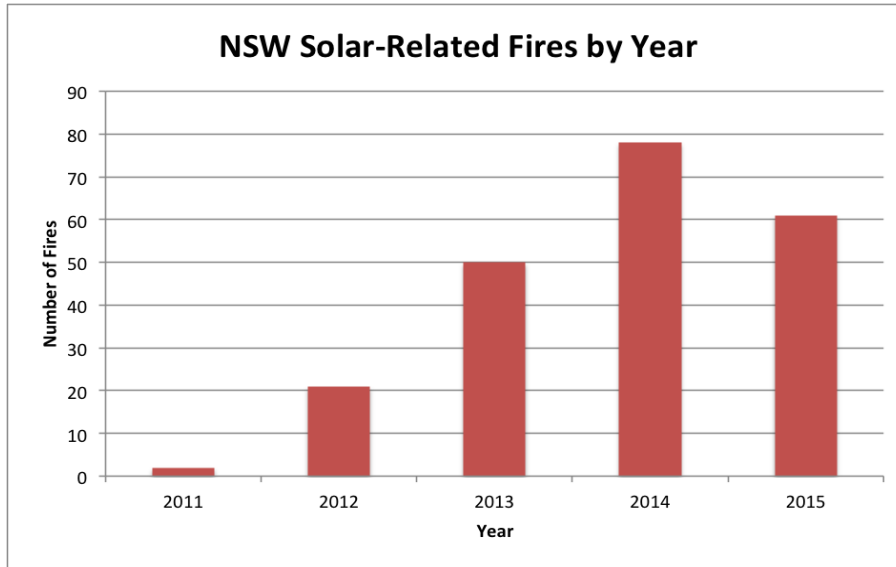

Figure 19: Solar-Related Fires in NSW from 2011-2015 (Data Source: FRNSW)

In 2015, the FRNSW switch from the AIRS reporting database to a new electronic eAIRS database. One informed source of FRNSW speculated that the number of recorded solar-related fires in 2015 could be skewed due to the transition into a new reporting database.

4.1.2 Causes of Solar-Related Fires

Data received from AFAC provided causes of solar-related for each state. The causes were categorised into 10 different types, which are shown in Figure 20.

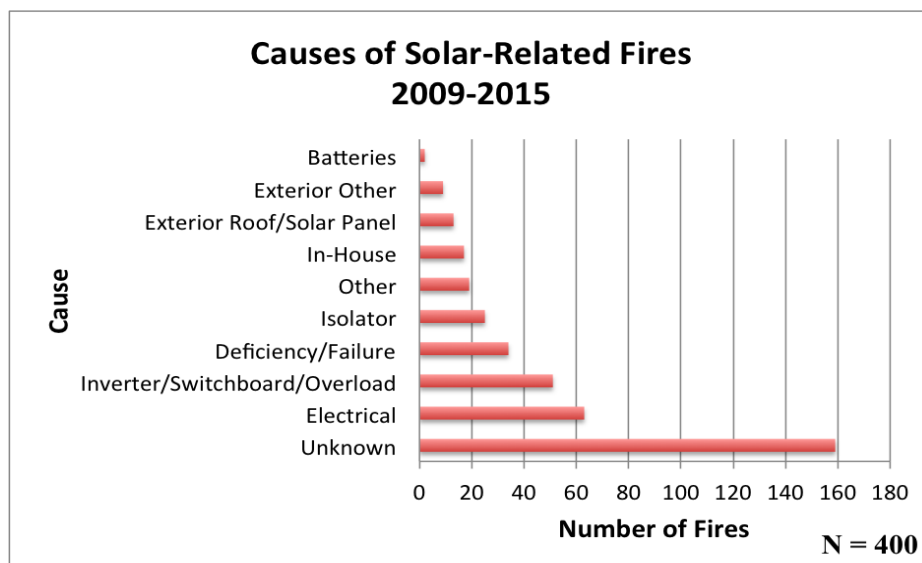

Figure 20: Causes of Solar-Related Fires in Australia (Data Source: AFAC)

Approximately 40% of the fires recorded had unknown causes. The largest known cause of solar-related fires classified the causative agent as a type of unknown electrical component, which accounted for almost 16% of the fires. Many components of a solar PV system such as the inverter, switchboard, and isolators are categorised as electrical equipment, however the data does not directly specify the cause. Therefore including the categories representing solar-related electrical equipment, approximately 35% of recorded solar-related fires were caused by solar-related electrical equipment. The deficiency/failure category (8.5%) could also overlap with solar-related electrical equipment. The in-house category consists of fires caused by ceiling fans, heating room units, receptacles and other appliances found inside a residential home where the solar PV systems was involved but was not determined to cause the fire.

Western Australia is the only state from the AFAC data with conclusive set of causes. Figure 21 shows the causes of solar-related fires for the 38 fires recorded in WA from 2009-2015.

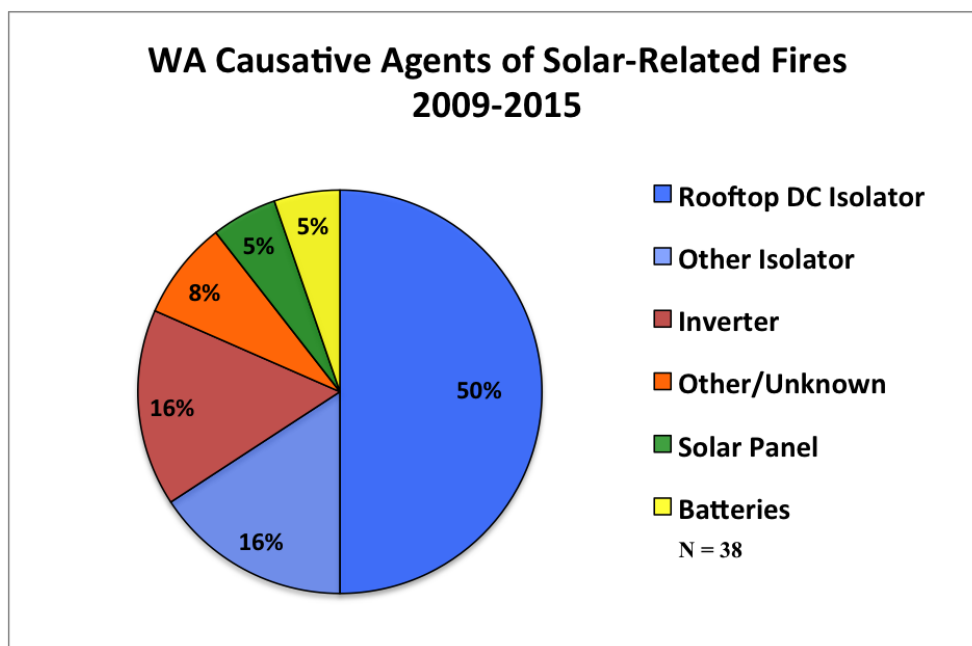

Figure 21: Causes of Solar-Related Fires in WA (Data Source: AFAC)

Two-thirds (25) of solar-related fires in Western Australia were caused by an isolator. Three isolators are used in a solar system; this includes the rooftop DC isolator, the AC isolator found near the inverter, and the DC isolator found near the inverter. The DC isolator at the inverter is not required for all solar PV systems. Nineteen of the reports specifically identified the rooftop DC isolator as being the causative agent of the fire. The inverter was ranked as the second highest causative agent at 16%, while other components such as solar panels and batteries accounted for the remainder of the data.

FRNSW data also recorded specific causes of the 221 solar-related fires from 2011 to 2015, as shown in Figure 22. Out of the 221 solar-related fires reported, more than a third (83) of the fires were caused by an isolator component of a solar PV system. An additional 31% of the solar-related fires reported had an unknown causative agent, which indicated that no specific solar component was directly linked to the ignition of the fires. According to a member of FRNSW, fires in the unknown category either spread to solar PV system components from the origin of the fire or hindered fire personnel operation due to the increased safety risk solar PV systems presented to firefighters, such as electric shock or restricted access (FRNSW-1, personal communication, 2016).

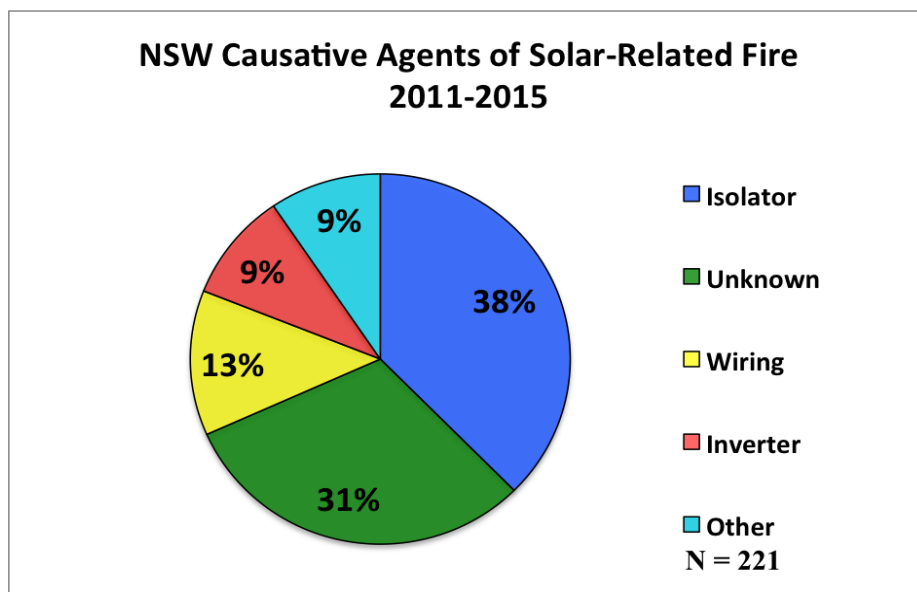

Figure 22: Causes of Solar-Related Fires in NSW (Data Source: FRNSW)

Electrical wiring and the AC inverter were causative agents of 49 of the 221 fires in NSW. Isolators, wiring, and inverters combined account for approximately 60% of all solar-related fires recorded by FRNSW. By eliminating the number of solar-related fires where the cause was unknown and not specifically linked to a solar-component (68), these three components are linked to 86% of all solar-related fires in NSW from 2011 to 2015.

To summarise, data retrieved from AFAC shows that 35% of the causative agents of solar-related fires was linked to electrical equipment of the solar PV system. Isolators, inverters, and switchboards are directly linked to 19% of the total fires. Western Australia, a sub-set of the AFAC data, specifically identifies 66% of solar-related fires to isolators and 16% to inverters. FRNSW, whose representation in unknown in the AFAC data, directly links 38% of solar-related fires to isolators and another 9% to the inverter. Due to the high number of unknown causes a specific component cannot be specifically identified as the leading causative agent of solar-related fires. However, based on known causes, solar isolators and inverters account for the majority of solar-related fires.

In addition to data obtained from AFAC and FRNSW, solar installers were asked questions pertaining to solar-related fires and their causes. Figure 23 displays survey responses received from solar installers. Over half of the survey respondents knew of at least one component that started fires within solar PV systems. Some installers made note of two

or more components within a solar PV system that could potentially be the causative agent of solar-related fires.

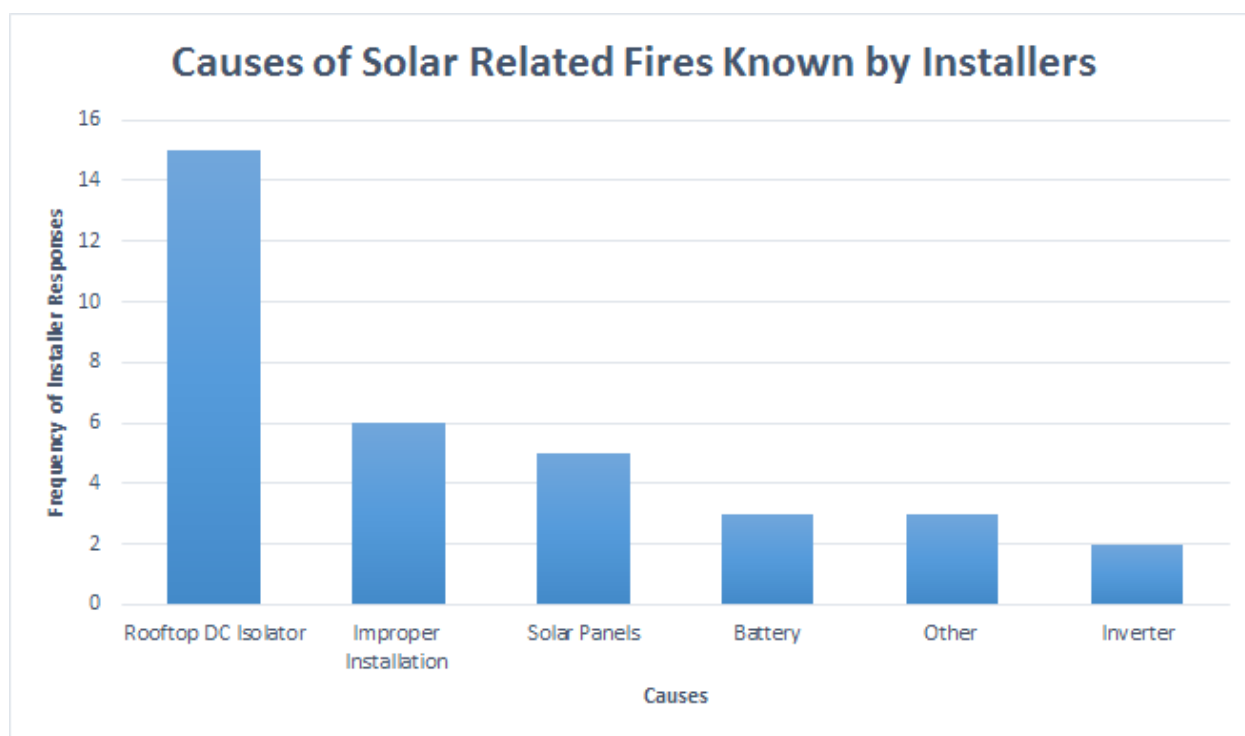

Figure 23: Causes of Solar-Related Fires Known By Installers (Data Source: WPI IQP Installer Survey)

As seen in Figure 23, installers linked the leading cause of solar-related fires to the rooftop DC isolator. The second leading cause that installers identified was improper installations of solar PV systems. Many of the installers believed that faulty installation practices are to blame for the increased fire risks with solar PV systems. One installer stated “Due to often difficult installation environment ... steep pitch, low to ground, poor footing ... it is harder for the electrician/installer to ensure all electrical connections have been adequately made...This increases the possibility of faulty installations” (WPI IQP Installer Survey, 2016). Another installer confidently stated that 80-90% of the rooftop DC isolator failures are due to poor installations. Installers also reported incidents of solar-related fires started by batteries, solar panels, and inverters.

Based on statistical data from fire services sources and anecdotal reports from solar installers, isolators are the most common causative agents of solar-related fires. A majority of these isolators are linked specifically to the rooftop DC isolator. However, solar-related wiring and inverters are also prevalent causative agents in solar-related fires. It is difficult to

determine whether faulty manufacturing of the components or faulty installations of a component by an installer is the main cause of isolators catching fire. Both factors combined offer an increased fire risk to solar PV systems.

4.1.3 Rooftop DC Isolators

Solar installers were asked to rate the overall effectiveness, benefit, and risk of the rooftop DC Isolator on a scale of 0 (lowest) to 4 (highest). The respondents were also allowed to give open-ended responses to provide an explanation for their specific rating. Figures 24 and 25 represent the results of the ratings given by installers.

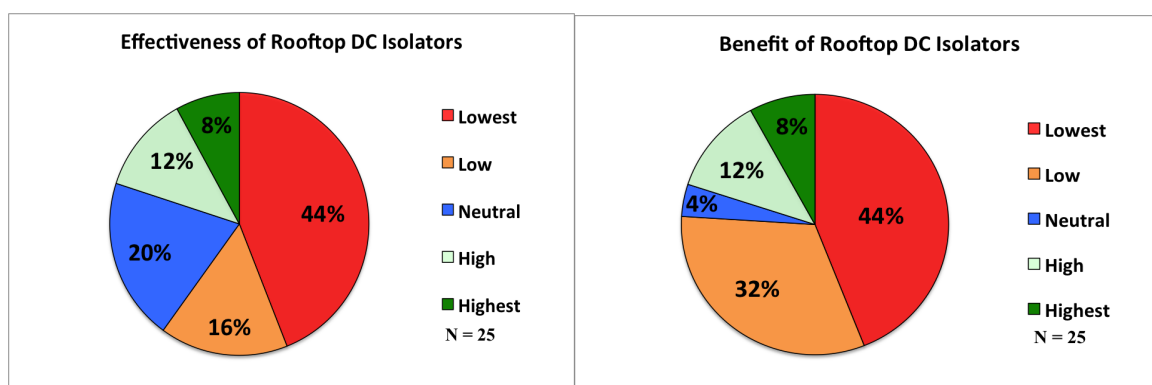

Figure 24: Effectiveness and Benefit of Rooftop DC Isolator Responses

(Data Source: WPI IQP Installer Survey)

When asked about both the overall effectiveness and benefit of rooftop isolators, over half (60%) of the respondents stated that there was little to no effectiveness of the rooftop DC isolator. Additionally, a majority (76%) of respondents stated there was little to no benefit of the rooftop DC isolator. Only one-fifth of the respondents in both questions assigned a rating of high or highest. One installer said, “I have never found a situation where the operation of a rooftop [DC] isolator has provided a safer situation” (WPI IQP Installer Survey, 2016). Other respondents pointed out the difficulties associated for firefighters to gain access to the rooftop DC isolators as well as the increased fire risk involved with this component.

Fewer than half of the respondents elaborated on benefits of the rooftop isolator. Most of the respondents referenced the additional convenience it allows for solar installers to install and maintain solar PV systems. Specifically, two solar installers noted that rooftop DC isolators are able to isolate voltage on the roof, thereby ensuring that no current flows off the

roof when an installer is working on any portion of the grounded system. In addition, if an electrician or installer needs to redo wiring, the isolator adds convenience to the process instead of physically disconnecting the wiring from the panels. One benefit to homeowners is that the rooftop DC isolator provides “peace of mind to the homeowner” (WPI IQP Installer Survey, 2016).

When asked about the safety risks associated with rooftop DC isolators, over four-fifths of the respondents claimed the devices to have a high safety risk (Figure 25). Responses were focused on the weathering and fire risks associated with devices. Factors such as harsh weather conditions lead to the breakdown of the system, which can increase the fire risk of the component. More than half of the respondents identified water ingress as one of the leading problems with DC isolators. Infiltration of water into the component can cause circuit shorts and increased fire risks. Additionally, many respondents stated that rooftop DC isolator serves no purpose for firefighters. One installer questioned, “If a device has a high rate of fire, how is it suppose to add safety and aid firefighters?” (WPI IQP Installer Survey, 2016). Others identified the device as the weakest point of failure in the solar PV system. From the installer responses, it can be inferred that installers feel that the rooftop DC isolator poses a greater risk than any added benefit, except during solar PV system installation.

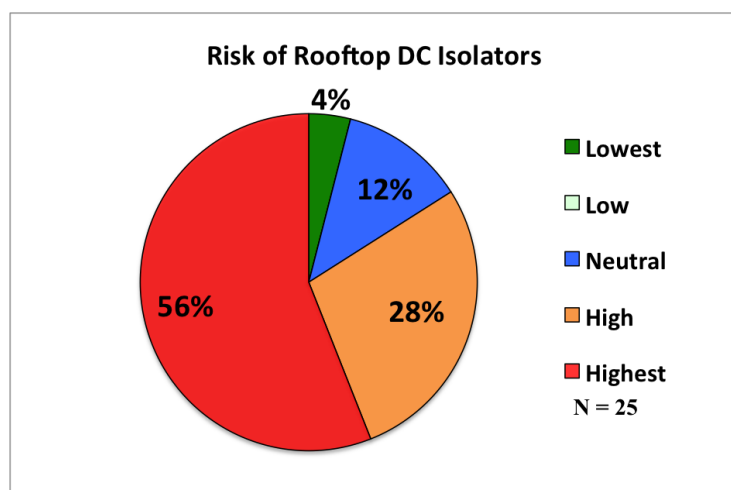

Figure 25: Risk of Rooftop DC Isolator Results (Data Source: WPI IQP Installer Survey)

4.2 Storage Battery Industry

The survey asked solar installers’ for their opinions of the solar energy storage industry. Many solar installers expressed their concerns about the safety of on-grid battery

storage systems. Although battery storage systems are a necessary component of off-grid PV systems, battery storage systems are also starting to be incorporated into on-grid solar PV systems. Solar installers' concerns addressed the lack of specific safety regulations for storage battery installations in these hybrid systems.

One installer stated that hybrid systems could become popular in Australia. A hybrid system enables solar customers to use electricity from two electrical power sources: the grid and batteries charged by their solar PV system. Any excess electricity generated is stored in the batteries and discharged later to avoid buying electricity from the grid during periods when the solar PV system is not generating sufficient power for the household. Once the battery source is depleted, power can be pulled from the grid to sustain daily usage. With high feed-in tariff schemes ending soon, hybrid systems may become a more economical option.

Some installers stated that although current Australian Standards for electrical installations are applicable to storage battery installations for PV systems, there is no specific standard that installers must follow when installing storage batteries. Consumers can purchase different types of batteries for their systems such as lead acid, lithium ion, or flow batteries. Each battery must be handled and installed appropriately due to the different chemical structures. The variation in chemical structure results in the batteries having diverse characteristics and operating parameters (Cavanagh et al., 2015). Differences in storage battery designs have created difficulties in establishing a universal training program for installers.

With the lack of definitive Australian Standards in place for the manufacturing and installation of storage batteries, some installers believe that problems in the industry will occur, such as faulty installations. One installer was quoted, "There is, however, the danger of poor workmanship with the results of failures that can lead to fires. People need to be trained up to a high standard to avoid the same hassle we had, and still have, with poorly trained and low ethical installers and sales companies." (WPI IQP Installer Survey, 2016). Although installers must be accredited by the CEC to install solar PV systems, there is currently no accreditation for on-grid storage battery installations in Australia or globally (Cavanagh et al., 2015). Without extensive training for installers, complications due to faulty installations can put the homeowners with a solar PV system at increased risk of fire.

4.3 Legislation Regarding Solar PV Systems

Legislation on solar PV systems was researched to obtain safety regulations and governmental policies set in place for solar PV systems. The ACCC was contacted to gain a greater understanding of the recent rooftop DC isolator recalls in Australia. Questions ranged from what qualify products for recalls, when a recall is initiated, the reason for product recalls, and how the recall process of the product is implemented. Current and past feed-in tariff rates across Australia were also researched to see how much homeowners benefit from excess electricity generated by their solar PV systems.

4.3.1 Safety Regulations on Solar PV Systems

As discussed in the background chapter, the *AS/NZ 5033* standard highlights electrical wiring requirements to reduce safety risks. In comparison, the National Fire Protection Association in the United States issues similar safety standards. Two codes, NFPA 1: Section 11.12 and NFPA 70: Article 690, pertain strictly to solar PV systems. NFPA 1: Section 11.12 determines the sizes of clearances and pathways for solar PV systems to aid firefighters in normal operations such as having access to necessary areas of the roof if ventilation is needed during a fire (NFPA 1, 2015). The code also provides the proper location for marking different components of the solar PV system so they are clearly identifiable (NFPA 1, 2015). NFPA 70: Article 690 is similar to *AS/NZ 5033* wherein it outlines the proper electrical safety guidelines for solar PV systems such as ground fault and overcurrent protection (NFPA 70, 2014). Though, the *AS/NZ 5033* standard does not set the exact location for marking labels on solar PV components nor does it set the sizes of clearances and pathways on the roof to allow for easier roof access.

The increase in solar-related fires has led to product recalls to ensure solar PV components are safe for consumer use. The Australian Competition and Consumer Commission (ACCC) responds to product recalls initiated by suppliers who are aware of a safety risk in their product. Usually reasons for recalls include inadequate quality of the product or lack of inspection by the producer. To date, seven recalls have been issued for the rooftop DC isolator component of solar PV systems due to electrical safety concerns (ACCC, personal communication, April 7, 2016).

Once a product recall is initiated, it is the responsibility of the supplier to inform the affected distributors of the recall. The manufacturer of the product notifies the warehouse distributor about their recalled product. The distributor contacts any solar installers who purchased the faulty product and then the installer must contact the consumer with the recalled product. Usually, the manufacturer replacing the recalled product will refund the solar installer. The ACCC monitors product recalls through the progress reports submitted by the supplier of the recalled product. For a recall to be issued, the product would be in violation of safety regulations outlined in the Australian Consumer Law (ACCC, personal communication, April 12, 2016).

The product recalls on rooftop DC isolators have caused fire service personnel to discuss the potential removal of the rooftop DC isolator mandate. “My initial reaction about removing it [the rooftop DC isolator switch] would be beneficial [to the solar PV system] ... [Although] the removal might affect a couple of applications,” stated an individual at Fire & Rescue New South Wales (FRNSW-1, personal communication, 2016). Several fire service members believe that revisions to the rooftop DC isolator mandate may be beneficial for solar PV systems.

4.3.2 Feed-In Tariffs

In Australia, most states and territories offer solar feed-in tariffs to consumers with small solar PV systems (and other renewable energy generators). Each state either mandates a minimum feed-in tariff rate or the rate is set voluntarily by electricity retailers (Martin II, 2015). Without a mandated minimum feed-in tariff rate set through legislation, electricity retailers are not obligated to provide a feed-in tariff whatsoever. However, retailers in each jurisdiction tend to offer feed-in tariffs to attract solar homeowners as customers (Martin II, 2015). When the solar industry in Australia significantly increased in scale from 2009 onwards, feed-in tariffs ranged between 44-60¢/kWh (Martin II, 2015). Today, feed-in tariffs have drastically decreased to generally range from 5-10¢/kWh (Martin II, 2015). Most feed-in tariff schemes have a termination date after which applicants are no longer accepted for the tariff; termination dates vary by state (Martin II, 2015). With grid electricity generally costing between 20-30¢/kWh in Australia, high feed-in tariffs are used to remunerate the solar home or business with the value of their exported solar electricity to the grid.

Early ‘premium’ feed-in tariffs are one of the primary reasons for the rapid growth of the solar industry in Australia between 2009 and 2012. The other is falling cost of the technology itself. Some premium feed-in tariffs are soon to be replaced by significantly lower feed-in tariffs, with some in Victoria, South Australia, and New South Wales slated to close to new customers by the end of 2016 (Martin II, 2015). Lower feed-in tariffs could possibly sway solar customers’ decisions to shift more of their consumption to the daytime; or install batteries in order to better utilise their solar energy in the evening. Thus, lower feed-in tariffs could be a factor for an increase in storage battery systems.

4.4 Firefighting Standard Operational Procedures

Australian fire services personnel were interviewed to gather a general consensus on standard operational procedures (SOPs) for solar PV systems across the country. Discussions with representatives from the different services revealed how firefighters assess the treatment of solar PV installation fires. After analysing the documentation and discussing operational procedures with fire services officials, additional risks related to solar PV systems were identified. Information regarding fire service standard operations was included in our fact sheet to inform homeowners of additional safety precautions, which would decrease property loss and aid firefighters during an emergency situation.

4.4.1 Solar PV Installation Fire Assessment

Standard operational protocols from Australian fire services classify solar-related fires as electrical fires. Standard fire safety guidelines for electrical fires requires all electrical current fed into the house to be shut off, including electricity from additional systems such as solar PV installations.

Upon arrival at the scene of a fire, the incident control officer of the respective fire service assesses the scene to determine the plan of operation. The priority for operational fire personnel is to shut off electrical power fed from the grid into the house. The presence of an alternative electrical supply to the building creates an additional SOP in which the fire personnel have to isolate the power from the source into the building. Alternative electrical supplies include solar PV installations, wind turbines, battery storage systems, or generators (FRNSW, 2012). To isolate the electrical feed from the solar PV panels into the house, fire

personnel must locate and switch off the electrical input from the grid at the main switchboard. Additionally, most firefighters will switch off the AC output at the inverter from the solar PV array, located next to the main switchboard (CFA, 2012). This ensures no additional electrical current is being fed into the house; however, the wires from the solar panels to the inverter are still potentially energised. Some fire service personnel will turn off the AC isolator next to the inverter to further isolate the system from the home (MFS, 2016).

Australian fire services follow the standard protocol outlined above, with the exception of the Department of Fire & Emergency Services Western Australia (DFES). DFES does not require personnel to turn off the inverter (DFES, n.d.). The main switch board turns off all electrical AC current feed into the house, including the electricity from the solar PV system (DFES, 2016). Turning off the inverter is an added safety precaution.

Fire services work in conjunction with the electricity distributors to ensure that electricity is not continually fed into the house. Several Australian fire services will contact the distributor for the property. In Victoria, when the distributor is not able to respond to the emergency, an accredited Country Fire Authority Victoria (CFA) member is capable of removing low voltage fuses in accordance with the SOPs (CFA, 2005). Low voltage fuses include any system that supplies a maximum of 480 volts to the building (CFA, 2005). CFA members accredited in low voltage fuse removals are required to complete a skills recognition package, which consists of a lecture, a theory assessment, and a scenario skills assessment (CFA, 2015). The CFA also notifies Energy Safe Victoria, a governmental independent technical regulator, to ensure that electrical protocols are followed correctly (CFA, 2012). Similarly, the Department of Fire & Emergency Services Western Australia notifies Western Power to assess and isolate the electrical risks on scene (DFES, 2016). Under no circumstances are fire personnel instructed to restore the electrical supply (CFA, 2005). Electricity can only be restored to the building after an inspection is completed by a licensed electrician or accredited installer (CFA, 2005).

Although the electrical power is isolated from the house's 240 volt wiring, solar panels continue to produce DC current in the wires from the solar panels to the inverter. To combat this issue, the Worcester Fire Department (WFD), DFES, and CFA utilise opaque tarpaulins to prevent light from striking the solar panels cells and generating electricity (WFD, 2014; DFES, n.d.; CFA, 2012). Safety concerns have arisen from the use of tarps on

solar PV systems. Most fire services are concerned that the research supporting the use of these tarps is indecisive on how effective the product is at eliminating the risk of electrocution (Backstrom & Dini, 2011). The Metropolitan Fire Service South Australia (MFS) and Fire & Rescue New South Wales (FRNSW) believe the risks of firefighters accessing the roof outweigh the benefits of de-energising the panels (MFS 2013; FRNSW, 2012). Standard operating procedures from MFS state, “the risks of personnel making access to a roof or other part of the structure where damaged PV arrays are present is not justified where the incident objective is loss prevention” (MFS, 2013). The standard protocols for the fire services are summarised in Table 1, however protocols can be altered for fire personnel to safely respond to an emergency situation.

Table 1: Summary of the Standard Operational Procedures

Standard Operational Procedures	WFD	CFA	FRNSW	MFS	DFES
Location	USA	VIC	NSW	SA	WA
General Assessment					
360 Walk Around	X	X	X	X	X
Isolate Electrical Power from Grid					
Contact Electrical Supplier		X	X		X
Government Independent Technical Regulator		X			X
Shut off Main Switch Board	X	X	X	X	X
Low Voltage Fuse Removal		X			
Isolate Electrical Power from Solar PV Panels					
Shut off Inverter	X	X	X	X	
Shut off AC Isolator		X	X	X	
Cover Solar Panels with Tarp	X	X			X
Shut off at Rooftop DC Isolator Switch		X (last resort)			X (last resort)
Additional Practices					
Roof Ventilation	X	X			

Interviews with fire service personnel revealed that SOPs for solar PV systems are still being updated. Current learning modules include assessment for low voltage fuse removals, electrical safety awareness, and SOPs to shut off the inverter and main switchboard. New training programs are now in progress to update current SOPs to focus specifically on operations involving solar PV systems (CFA-1, personal communication, 2016).

4.4.2 Firefighters & Rooftop DC Isolator

Although the rooftop DC isolator was proposed for firefighters to have an accessible switch to isolate the DC current between the panels and the house, the rooftop DC isolator

component is not mentioned in the SOPs for most Australian fire services (Holden, 2015). The Department of Fire and Emergency Services of Western Australia determines that isolating electrical current from the solar PV panels is only required if conditions are determined to be safe by the risk assessment officer (DFES, n.d.).

According to an informed source at the CFA, the rooftop DC isolator is not utilised. If conditions permit the firefighter to do so, then the switch can be utilised as a last resort. Conditions include that the solar panels are not damaged and all wiring from the system must be intact. In January of 2016, CFA released an incident report regarding a rooftop DC isolator switch. An operational firefighter was extinguishing a fire at the isolation switch on the roof when he received a minor electrical shock. CFA does not isolate the solar PV panels at the rooftop DC isolator switch during fire operations. Similar to the CFA, Fire & Rescue New South Wales has not utilised a rooftop DC isolator switch even though it is permitted in the SOPs. One informed source from FRNSW stated, “I have not used one [rooftop DC isolator switch] and our experience using one is very limited because we [FRNSW] do not stand above a fire” (FRNSW-1, personal communication, 2016).

Although rooftop DC isolators are not a required component of solar PV systems in the United States, rooftop disconnects do exist. In a document provided by the Worcester Fire Department (WFD), under no circumstances is the rooftop disconnect to be used for power isolation (WFD, 2014). Rooftop disconnects are primarily used for convenience during maintenance to the system.

4.4.3 Additional Risks of Solar PV Systems for Firefighters

An analysis of the documentation acquired from the Australian fire services identifies additional risks to firefighters associated with solar PV systems. During an emergency response, operational personnel have to account for various risks when a solar PV system is present. An informed source of FRNSW agreed that a residential house with a solar PV system has an increased risk of property loss resulting from a fire as compared to a residential house without a system. His explanation was that a solar PV system could hinder firefighter operations to contain the fire (FRNSW-1, personal communication, 2016). Timely operations to contain a fire within a single room or portion of a residential house can be influenced by the extra precautions firefighters need to take to ensure safety when working around a solar

PV system. These precautions include the added procedures to shutdown the system, potential failure of solar PV components and continuation of live current throughout the residential home.

Conduction of electrical current through water is also a risk when operational personnel spray the high-powered engine hose at the inverter or the components of the solar PV system (MFS, 2013). In the event of severe flooding, homeowners are responsible for calling an electrician to power down their system. If the system is not turned off and a flood occurs, the floodwater will become live (FRNSW, 2012). After a natural disaster, damaged solar panels and their cables can also come into contact with conductive building materials. Conductive materials in contact with solar panels increases the electrical safety boundary. Firefighters mark anything within an eight-meter boundary as an exclusion zone, limiting firefighter response to areas outside this zone (FRNSW, 2011).

After shutting off the electrical feed into the home, operational personnel must still be cautious of their surroundings. A few reported cases mentioned anti-islanding equipment failure (CFA, n.d.). Anti-islanding protection ensures that if a power surge occurs, the inverter shuts itself off. Problems with the anti-islanding protection can affect standard firefighter operation. Even though the inverter is turned off, anti-islanding equipment failures can cause electrical power to still be fed into the house (Country Fire Authority, n.d.) This issue can arise from a solar PV installation with an uninterruptible power supply (UPS). UPS includes battery backup systems and generators, which turn on as a backup power supply when electricity is cut from the grid (FRNSW, 2012). Some of these systems are difficult to identify and therefore electricity can be continuously supplied to the house without operational personnel being aware of the situation (FRNSW, 2011).

Storage batteries present similar problems for Australian fire services to those of solar PV systems. The interviewed fire personnel from Victoria and New South Wales expressed their concern with battery storage for on-grid systems and the potential problems that could arise. As with solar PV systems, storage batteries are an uninterrupted power source that will continue to provide power to the home even though the power from the grid has been disconnected to the building. Batteries concentrate and store energy, with the potential for large amounts of energy to be released in a short time. Firefighters are concerned with the increased risk of electrical shock when firefighters have a false sense of security believing all

power has been isolated from the house. An informed source from Fire & Rescue NSW was concerned about the lack of hazard identification and signage for storage batteries as well. He stated, "...naturally people want to conceal them [storage batteries] as much as possible, which makes it more difficult for us [fire personnel] to notice them... If you do not know about it, you cannot isolate it" (FRNSW-1, personal communication, 2016).

Issues can arise for operational personnel once they arrive on-site to a house fire with a solar PV system involved. While completing a general assessment, one problem that arises is locating the inverter box, which can delay operations for the firefighters. Currently, there are no standards for the location of the inverter on the property (CFA, 2012). The inverter can be located on the outside or inside of the house (CFA, 2012). Lack of universal standards also cause issues with the routing of wiring from the solar PV panels to the inverter box (DFES, 2016). An incident was reported in which a firefighter was using standard techniques to ventilate the building (CFA, 2016). The firefighter received a minor electrical shock and was treated on scene. After assessing the situation, the control unit determined the source of electrical shock was from DC wiring from the solar panel through the ceiling towards the inverter (CFA, 2016).

Documentation received from fire services identified additional safety risks associated with solar PV systems during operations. By being aware of SOPs performed by fire services personnel, homeowners can mitigate safety risks associated with solar PV systems. Interviews with informed sources clarified that in case of an emergency, homeowners should ensure that fire personnel have easy access to the main switchboard and inverter.

5. Conclusion & Recommendations

Solar PV installations present fire safety concerns for both homeowners and fire services. However, the risks associated with these systems can be reduced through precautionary actions. This chapter includes a summary of our research and recommendations to reduce the fire safety risks of solar PV installations.

5.1 Summary

The increase in solar PV installations over the past years has led to research in electrical and fire safety concerns of these systems. The goal of this project was to analyse the potential risks associated with solar PV systems by gathering information from fire services personnel and solar installers.

Fire services personnel interviews and solar installer surveys were collected to determine potential risks associated with solar PV systems. In addition, information was retrieved from AFAC for causes of solar-related fires across Australia. Identified risks associated with solar PV systems include faults from electrical wiring, water ingress in rooftop DC isolators, overload in the inverter switches, and moisture build up within the solar panels. Solar installers verified that faulty installation practices could increase the risk of fires in solar PV systems. It was determined that solar PV systems cause additional risks for the Australian fire services during a house fire. The presence of a solar PV system causes firefighters to take additional precautionary measures that can result in a delay of operational procedures.

A fact sheet was produced for ATA to distribute to homeowners to raise community awareness of solar PV system safety concerns. This fact sheet highlighted the risks associated with solar PV systems and suggested proactive steps homeowners can utilise to reduce fire risks. The fact sheet is shown in Appendix E: Fact Sheet for ATA - Solar PV & Fire Risks. Raising awareness of the fire risks associated with solar PV installations can motivate organisations such as the CEC and Australian Standards to update safety guidelines to benefit the safety and growth of the solar industry. In addition, a secondary fact sheet was created to raise awareness to homeowners about storage battery systems. The fact sheet is shown in Appendix F: Fact Sheet for ATA - Battery Storage Systems.

5.2 Recommendations

Based on the results from the interviews with fire services personnel, surveys with solar installers, and data collected we formulated the following recommendations. These recommendations were established for homeowners and organisations, such as the Alternative Technology Association (ATA), the Clean Energy Council (CEC), and the Australian Fire & Emergency Service Authorities Council (AFAC) for the betterment of the solar industry.

5.2.1 Recommendations for Homeowners

Homeowners with solar PV systems can reduce fire and electrical risks posed by these installed systems. By being proactive, homeowners can mitigate the risks to fire services, accredited installers, licensed electricians, and themselves.

We recommend that homeowners ensure that their solar PV system complies with the current labelling standards.

To mitigate the risk of electrocution, we suggest that the homeowners ensure that their solar PV system is properly labelled. According to the Australian standard *AS/NZS 5033: Installation and safety requirements for photovoltaic (PV) arrays 2012*, a sign must be located next to the inverter showing that a PV array is present. Instructions to turn off the electrical current from the system must also be displayed (MFS, 2013). However, some older solar PV installations do not comply with this standard (MFS, 2013).

Additionally, it is beneficial for homeowners to have a diagram next to the inverter displaying the location of DC wiring throughout the house. Fire services personnel identified the inability to detect DC current as a major risk associated with solar PV systems (CFA, n.d.). Installation standards for solar PV systems do not have specifications for the location of wiring from the solar PV system to the inverter, thus allowing hazardous DC wiring to be located throughout the walls and ceiling of the house. A diagram will reduce the risk of electrocution for fire services personnel and will also be helpful for installers or electricians performing maintenance on the solar PV system (CEC, 2014b). In addition to reducing the risk of electrocution, a properly labelled system assists operational personnel during an

emergency situation by identifying the location of additional components of the solar PV system.

We recommend that homeowners contact an accredited installer or an electrician to check their solar PV system after a natural disaster or severe storm.

Homes with solar PV installations affected by floods are a major safety concern. Even though the solar PV system may be turned off, floodwater that comes into contact with the panels can become live. To decrease risk of electrocution, the PV system should be turned off before a flood at the inverter. Following a flood, owners should contact an accredited installer or an electrician to check the system for any electrical faults (FRNSW, 2011).

After a severe storm, a homeowner should contact an installer or an electrician to assess the condition of their solar PV system. Damaged solar PV systems have increased electrical and fire hazards. If a damaged solar panel comes into contact with a conductive surface, the electrical charge can travel up to eight meters from the point of contact (FRNSW, 2011). To reconnect their PV system following a natural disaster, it is recommended that a homeowner should contact licensed electrician or accredited installer (FRNSW, 2011).

We recommend that homeowners perform a visual inspection of their solar PV system annually.

Proper maintenance of a solar PV system can reduce the probability of solar PV components causing a fire. A homeowner should visually inspect their solar PV system, if it is feasible and safe to do so, at least once every year. During the visual inspection, the homeowner should look for deterioration of the components or any loose panels. Homeowners should be aware of any debris build up on or around the panels as well. Excessive debris build up can reduce electrical output of the system and increase fire risk.

Mandatory inspections of solar PV systems vary depending on the state electrical authority (CEC, 2014b). One accredited solar installer suggested that a solar PV system should be inspected professionally once every five years (Anonymous, 2016).

We recommend that homeowners monitor their solar PV system output monthly.

In addition to conducting a visual inspection of the system, it would be beneficial for the homeowner to monitor the electrical output of their system monthly. The output of the solar PV system can be monitored from the inverter. On a sunny day, the system should be producing an electrical output of approximately 80% of its total capacity. If the system output is significantly below this threshold value on a standard sunny day, it is advised that the homeowner schedule an inspection of the system. Accredited installers stated that continuous low electrical output usually correlates to a problem in the solar PV system (Anonymous, 2016). Some installers noted that most output problems were directly related to rooftop DC isolator malfunctions (Anonymous, 2016). Monitoring the monthly output of the solar PV system may allow homeowners to identify minor issues before they develop into fire risks.

We recommend that homeowners be aware of product recalls on components of solar PV systems.

Homeowners should be aware of the brand of solar panels and components of their system. Since 2014, the ACCC has issued product recalls on seven rooftop DC isolators due to electrical safety hazards. If a product recall is issued, a solar installer should contact the consumer to remove the component. A replacement product will be installed or the consumer will receive a refund for the recalled product. As a precautionary measure, the consumer should ensure that the desired components for the solar PV system are CEC approved before installation. In addition, the ACCC and the CEC releases an updated list of recalled products. Current product recalls for solar PV systems can be found on the ACCC website (<https://www.accc.gov.au/search/accc-funnelback/rooftop%20DC%20isolator?filter=0%3ARecalls>) or the CEC website (<https://www.solaraccreditation.com.au/products/product-recalls.html>).

We recommend that homeowners look into devices that can potentially make their solar PV system safer and more efficient.

Another option to increase the efficiency of a solar PV system is the use of DC optimisers. DC optimisers are installed behind each panel in an array to maximise the overall efficiency of solar PV systems through efficient DC-to-DC conversion (Martin II, 2012). DC

optimisers use maximum power point tracker technology that tracks and maintains maximum power of each module in the array. For example, a solar PV array on a roof without DC optimisers can be hindered by a single shaded module operating at a lower voltage. The lower voltage from the shaded panel causes the whole array to operate at a low voltage. Thus, less electricity is output from the PV array.

DC optimisers hold the voltage of the string at the optimal point for DC to AC conversion. This allows each panel in an array to operate independently from the other panels in a string and remain unaffected by one shaded panel (Martin II, 2012). A solar PV array with DC optimisers can raise the total power output of the array by as much as 25% compared to the power output of a solar PV array without DC optimisers (Martin II, 2012).

The key benefits of DC optimisers include easy monitoring for homeowners and safety precautions to protect the solar PV system. DC optimisers contain wireless technology that allows homeowners to monitor their system remotely (Martin II, 2012). From a safety aspect, DC optimisers have a module-level shutdown feature and arc detection capabilities (SolarEdge, n.d.). When a building is disconnected from the electrical grid, DC optimisers switch into a safety-mode that shuts down the DC current supplied by the panel and reduces the output voltage of each panel to 1V (SolarEdge, n.d.). DC optimisers also act as module-level arc detectors. Optimisers have the ability to terminate the current by shutting off all modules in the array when an electrical arc occurs (SolarEdge, n.d.).

Two drawbacks of DC optimisers are the expense and increased probability of system failure. DC optimisers can be relatively expensive since one optimiser is installed on each panel. Installing DC optimisers on each panel also increases possible points of failure in a solar PV system. The exposure of the DC optimisers on the roof can lead to safety concerns similar to those associated with the rooftop DC isolator, however the addition safety features and benefits outweigh these risk.

Microinverters are another optional component for solar PV systems. A microinverter converts the DC electrical current produced by the solar panels into AC electrical current that is utilised by household appliances. By installing microinverters to the solar PV system, a rooftop DC isolator component is not necessary. On a typical system, microinverters are located inside the inverter, however these devices can also be installed directly on the solar panel, which provides three main advantages over rooftop DC isolators. First, they eliminate

the risk of homeowners, installers or repair personnel, and fire personnel being exposed to high DC voltages through wiring since the voltage conversion to AC is performed at the panels. Second, microinverters reduce the risk of a complete system failure that occurs in a normal string inverter. If one microinverter fails in a single solar panel, the remaining panels will still continue to produce electricity unlike a complete system failure with a normal string inverter, where the entire system stops producing electricity. Finally, microinverters also have the potential to be more productive and tend to have a longer product warranty, up to 10 to 25 years, depending on the brand, compared to the expected useful life of string inverters that can have a warranty of up to only 10 years (Martin, 2016).

Two disadvantages of microinverters include the additional installation costs to the system and additional maintenance concerns. Microinverters can range up to \$1800AUD for a 10kW system (Martin, 2016). This cost can vary significantly depending on the number of panels installed in the system and proportionally the number of microinverters needed for the system. Microinverters add a risk factor to the system because the microinverter is located within each panel. Repairs to the systems must be completed on the roof in the panel of the damaged microinverter, which incurs additional costs of repair (Martin, 2016).

5.2.2 Recommendations for ATA

The Alternative Technology Association strives to inspire and educate homeowners to live sustainably in their homes and communities. This includes educating homeowners about the risks that are associated with innovative renewable technology and informing homeowners about ways to mitigate these risks.

We recommend that the ATA educate its members and homeowners on best safety practices of solar PV systems including storage batteries via informational documents and/or videos.

Solar PV systems are constantly being introduced with innovative features. With new on-grid storage batteries being introduced, understanding solar PV systems and the complexity of those systems poses a greater challenge than ever before for the consumer. By producing informational media, ATA can educate homeowners about new technology and can help mitigate the increasing risks involved with storage battery technology. Additionally,

keeping homeowners up to date on current legislation and how homeowners can comply with the most recent standards can play a key role in mitigating risk for both the homeowner and emergency services in the event of an emergency. This proactive approach to safety will lead to fewer problems going forward with the industry.

We recommend that ATA advocate for the removal of rooftop DC Isolators in the AS/NZ 5033 standard.

A significant number of solar-related fires have been attributed to the rooftop DC isolator, mandated for all installations performed after 2012. In 2015, there was a decrease in the number of solar-related fires. As stated before, five brands of DC isolators that accounted for over 3,900 installations in Queensland were recalled in 2014, all for problems that led to increased risk of fire. Results from surveying solar installers show a bias towards increased risk over any benefit these devices add. In addition, the original rationale for the mandatory installation of rooftop DC isolators was in part to allow firefighters to have an additional isolation point near the panels. However, interviews conducted with sources from fire services reveal that most firefighters will not utilise them. The few fire services that will utilise the switch will only use it as a last resort when there is absolutely no additional risk. Therefore, it would be most beneficial to consider removing the mandate for this component (Appendix G: Support for the Rooftop DC Isolator Mandate Removal).

5.2.3 Recommendations for Other Organisations

Governing organisations relevant to solar PV systems have an important role in ensuring proper installations of solar PV systems and their components. These organisations have a direct impact in how the renewable energy market performs by releasing new safety standards and updating accreditation processes.

We recommend that safety installation standards be fully developed for storage battery systems.

Sources suggest that storage batteries will become an attractive addition to on-grid solar PV systems for homeowners. Many solar PV system installers voiced concerns about

faulty installations with storage batteries. This concern stemmed from the lack of solar PV system storage battery standards for installations in Australia (Cavanagh et al., 2015).

The CEC and relevant governing bodies should implement safety standards for the installation of storage batteries for on-grid solar PV systems. Current guidelines exist as of April 2016, however installers are not mandated to follow these guidelines (CEC, 2016). The CEC should also create a training program and accreditation process, specific to storage battery systems and different types of batteries, for solar PV system installers. Accreditation and training programs can allow for installers to be knowledgeable in the storage battery area as well as provide a high level of service for homeowners looking to invest in storage battery systems. By providing storage battery system accreditation, potential dangers of faulty installations can be minimised, thereby reducing potential risks to homeowners in Australia.

We recommend that Australian fire services & governing bodies collaborate to produce and update training for fire personnel on solar PV system storage batteries.

Through interviews conducted with Australian fire services, fire personnel expressed their concern for the future of battery storage and fire safety risks for both homeowners and fire personnel (FRNSW-1, personal communication, 2016). Emergency services have limited knowledge on the issues presented by energy storage incidents such as fire and how to control them (Cavanagh et al., 2015). Additionally there is a lack of testing on proper extinguishing methods for storage batteries in the event of a fire (Cavanagh et al., 2015).

Fire operational personnel need adequate training for situations involving storage batteries connected to on-grid solar PV systems to help reduce risk to firefighters during a fire. Updated training procedures to include on-grid solar PV storage batteries on uninterruptible power supplies (UPS) should be created to best prepare operational personnel. In addition, fire services should collaborate with research facilities to identify a proper approach to controlling energy storage system dangers, including fire, in the event of an emergency.

We recommend that Australian fire services update incident reports to include solar-related fires.

Through our analysis of data provided by AFAC and FRNSW, documentation of solar-related fires is not well recorded. Documentation of incidents involving solar PV systems should include options such as ignition factors from electrical wiring of the system, rooftop DC isolator, PV array AC isolator or any other components of the solar PV system involved on the fire incident. Notation of specific brands of the components may be beneficial to determine an increased fire risk from lower quality products. By updating the incident reporting document for the eAIRS database, trends of solar-related fires may be identified to further investigate faults associated with the solar PV systems.

5.2.4 Recommendations for Future Projects

Solar PV systems are growing in demand throughout Australia, as well as different countries such Germany, United States, Israel, and others. As more consumers decide to purchase solar PV systems, problems could potentially arise including the potential for added risk in the event of bushfires and the recycling/proper disposal of solar PV panels and storage batteries.

We recommend that a future project be completed on bushfires and solar PV systems.

A major concern brought to our attention from the NFPA and AFAC was the issue of bushfires and solar PV systems. In rural areas with a dry climate, bushfires have an increased probability of occurring. Some solar PV system installations are situated so that PV panels are installed at an angle with respect to the roof or the ground. This can lead to debris collecting under the panels that can increase risk to homeowners. In the case of a bushfire, flying embers can possibly ignite the debris that has collected underneath a solar PV panel. A research project group should determine if there is in fact an increased risk to homeowners in the event of a bushfire due to debris that can collect underneath solar PV panels.

We recommend that a project be completed on proper ways to dispose/recycle solar PV panels and storage batteries.

Solar PV panels and batteries contain toxic materials. With the solar industry growing at such a fast rate in Australia, proper disposal of used or damaged panels can be challenging. Currently most lithium-ion battery storage systems are not recycled in Australia (Cavanagh et al., 2015). Further problems may arise with the increased number of dangerous storage battery components. As systems degrade over time, disposal of panels and batteries should be monitored. Proper techniques to recycle or dispose of panels and batteries could be beneficial to the advancing solar technology industry.

References

- ACCC. (n.d.). Product safety recalls Australia. Retrieved on April 12th, 2016 from <http://www.recalls.gov.au/content/search/index.phtml?query=DC+Isolator&collection=recalls>
- ACCC. (2014). NSW: Recall of solar isolators. Retrieved from <http://www.productsafety.gov.au/content/index.phtml/itemId/1007368>
- AGL. (n.d.). The power of premium solar panels. Retrieved from <https://aglsolar.com.au/solar-power-with-agl/>
- Alternative Technology Association, Banksia Gardens Community Services, CERES Community Environment Park, CSIRO Education, Melbourne Museum - Scienceworks, & Metropolitan Emergency & Fire Service Board. (2015). *Melbourne D16 project briefs*.
- Aston, H. (2015). Solar experts claim multi-billion dollar subsidies wasted on cheap and dodgy panels. *The Sydney Morning Herald*. Retrieved from <http://www.smh.com.au/environment/solar-experts-claim-multibillion-dollar-subsidies-wasted-on-cheap-and-dodgy-panels-20150220-13kqub>
- Australian Government. (2000). Renewable Energy (Electricity) Act 2000. Report No. 174. Retrieved from <https://www.legislation.gov.au/Details/C2015C00313>.
- Australian Renewable Energy Agency. (2015). Australian PV institute solar map. Retrieved from <http://pv-map.apvi.org.au/analyses>
- Backstrom, R., & Dini, D. (2011). *Firefighter safety and photovoltaic installations research project*. Underwriters Laboratories Inc.
- Barnett, M., Bruck, D., & Jago, A. (2007). *Mean Annual Probability of Having a Residential Fire Experience Throughout a Lifetime: Development and Application of a Methodology*. International Association for Fire Safety Science. Retrieved from http://www.iafss.org/publications/aofst/7/85/view/aofst_7-85.pdf
- Brooks, B., Bunting, S., Cercos, F., Enea, D., Hostetter, J., Kateley, S., . . . French, M. (2010). *Fire operations for photovoltaic emergencies*. California: CAL FIRE - Office of the State Fire Marshal.
- Carson, L., Bradshaw, M., Jacques, L., Che, N., & Ball, A. (2010). *Chapter 10: Solar energy* Australian Energy Resource Assessment.
- Cavanagh K., Behrens S., Price C., Lim O., Haigh N., Fleming A., Oliver E., Mankad A., and

- Bhatt A. I. (2015). *Energy storage safety: Responsible installation, use and disposal of domestic and small commercial battery systems*. CSIRO report EP156209, Australia.
- Clean Energy Council. (2014a). Accreditation process. Retrieved from <https://www.solaraccreditation.com.au/installers/becoming-accredited.html>
- Clean Energy Council. (2014b). After installing solar. Retrieved from <https://www.solaraccreditation.com.au/consumers/after-installing-solar-PV.html>
- Clean Energy Council. (2015a). *Best practice regulation of the Australian solar industry*. Australia: Clean Energy Council.
- Clean Energy Council. (2015b). *Clean Energy Australia Report 2014*. Australia: Clean Energy Council. Retrieved from <https://www.cleanenergycouncil.org.au/policy-advocacy/reports.html>
- Clean Energy Council. (2016). *Grid-connected energy systems with battery storage*. Australia: Clean Energy Council.
- Considine, P. (2013). *Safety consideration for photovoltaic arrays*. Australia: Australian Fire and Emergency Service Authorities Council.
- Country Fire Authority. (2012). *Operations Bulletin 002/2010: Alternative Electrical Supplies – Photovoltaic Arrays (Solar Panels)*. Unpublished Internal Document.
- Country Fire Authority. (2016). *Safety First: Alert No. 39 Electrical Safety*. Unpublished Internal Document.
- Country Fire Authority. (2015). *skills PAK: Low voltage fuse removal*. Unpublished Internal Document.
- Country Fire Authority. (n.d.). *Solar Panels and the DC Danger Zone – Reducing Risk Factors for Fire Fighters*. Unpublished Internal Document.
- Country Fire Authority. (2005). *Standard Operating Procedure: Low Voltage Fuse Removal*. Unpublished Internal Document.
- Department of Fire & Emergency Services, Western Australia. (n.d.). *Alternative Energy Systems*. Unpublished Internal Document.
- Department of Fire & Emergency Services, Western Australia. (2016). *Directive 3.4 – Structural Fire: SOP 3.4.8 – Electrical Hazards*. Unpublished Internal Document.
- Fire & Rescue New South Wales. (2011). *Utilities SOGS (NO. 14.2 – 14.7): 5. Alternative power sources*. Unpublished Internal Document.

- Fire & Rescue New South Wales. (2012). *Utilities SOGS (NO. 14.7):14.7 Alternative Power Sources*. Unpublished Internal Document.
- Foran, J., & Williams, L. (n.d.). *PVSTOP product information*. Solar Developments.
- Grant, C. (2013). *Fire fighter safety and emergency response*. National Fire Protection Association.
- Ground fault protection. (2015). Retrieved from <http://www.littelfuse.com/products/protection-relays-and-controls/protection-relays/protection-relay-pages/ground-fault-protection.aspx>
- Holden, A. (2015). The problem with DC isolators. *Ecogeneration*. Retrieved from http://ecogeneration.com.au/news/the_problem_with_dc_isolators/99360
- IMO. (2014). *Solar isolator brochure*.
- International Energy Agency. (2015). A snapshot of global PV (1992-2014). Retrieved from http://www.iea-pvps.org/fileadmin/dam/public/report/technical/PVPS_report_-_A_Snapshot_of_Global_PV_-_1992-2014.pdf
- Kukreja, R. (2016). Disadvantages of solar energy. Retrieved from http://www.conserve-energy-future.com/Disadvantages_SolarEnergy.php
- Linked Group Services. (2016). ISO Covers. Retrieved from <http://www.linked.net.au/services/solar/linked-isocovers/>
- Martin, J. (2016). Micro inverters: Are they right for your solar system. Retrieved from <http://www.solarchoice.net.au/blog/microinverters-home-solar-systems>
- Martin II, J. (2015). When do the solar feed-in tariffs end? A state-by-state look. Retrieved from <http://www.solarchoice.net.au/blog/when-do-feed-in-tariffs-end-NSW-QLD-VIC-ACT-TAS-SA-WA-NT>
- Mercer, P. (2014). Is Australia falling out of love with solar power? *BBC News*. Retrieved from <http://www.bbc.com/news/business-25751086>.
- Metropolitan Fire Service, South Australia. (2013). *South Australian Metropolitan Fire Service Operations Bulletin 03*. Unpublished Internal Document.
- Morris, N. (2014). *Lithium what? know your lithium ion battery technologies*. Retrieved from <http://www.solarchoice.net.au/blog/lithium-what-know-your-lithium-ion-battery-technologies>

- NFPA 1: Section 11.12 Photovoltaic Systems, 2015 Edition. In *NFPA National Fire Codes Online*. Retrieved from <http://codesonline.nfpa.org>
- NFPA 70: Article 690 Solar Photovoltaic (PV) Systems, 2014 Edition. In *NFPA National Fire Codes Online*. Retrieved from <http://codesonline.nfpa.org>
- Projoy Electric. (2015). *A principle of selecting DC isolators for PV systems*. Retrieved from <http://www.projoy-electric.com/en/industry-info/18/pv-system-dc-isolator-model-selection>
- Reddaway, A., & Moyses, D. (2015). *Household battery analysis*. Alternative Technology Association.
- Sadler, L. (2015). So dodgy panels, dodgy DC isolators, dodgy installers? Retrieved from <https://www.solar-safe.com.au/dc-isolator-recall/dc-isolators-need-to-be-removed>
- Shahan, Z. (2014). World solar power capacity increased 35% in 2013. Retrieved from <http://cleantechnica.com/2014/04/13/world-solar-power-capacity-increased-35-2013-charts/>
- Sherwood, L., Backstorm, B., Sloan, D., Flueckiger, C., Brooks, B., & Rosenthal, A. (2013). *Fire classification rating testing of stand-off mounted photovoltaic modules and systems*. Solar America Board for Codes and Standards.
- Shipp, M., Holland, C., Crowder, D., Pester, S., & Holden, J. (2013). Fire safety and solar electric / photovoltaic systems. *Fire*, 107, 33.
- Smith, A. M. (2016). Redflow takes on tesla powerwall with Z-Cell home battery. Retrieved from <http://www.smh.com.au/business/energy/redflow-takes-on-tesla-powerwall-with-zcell-home-battery-20160329-gntpfi.html>
- SolarBusinessServices. (2014). *Industry report: Solar businesses in Australia*.
- Solar Choice. (2015). Imergy's vanadium flow batteries in Australia. Retrieved from <http://www.solarchoice.net.au/blog/imergy-vanadium-flow-batteries-australia>
- SolarEdge. (n.d.). *Safety risks & solutions in PV systems*. Retrieved from <http://www.solarchoice.net.au/blog/wp-content/uploads/Safety-Risks-Solutions-in-PV-Systems.pdf>
- Solar Energy Industries Association. (2015). Solar industry data. Retrieved from <http://www.seia.org/research-resources/solar-industry-data>
- Spooner, T. (2011). *Solar electric systems - safety for firefighters*. Australian PV Association.
- Standards Australia. (2012). Installation and safety requirements for photovoltaic (PV)

- arrays. Standards Australia/Standards New Zealand.
- Stapleton, G., Neill, S. & Milne, G. (2013). Photovoltaic systems. Retrieved from <http://www.yourhome.gov.au/energy/photovoltaic-systems>
- Wills, R., Milke, J., Royle, S., & Steranka, K. (2014). *Commercial roof-mounted photovoltaic system installation best practices review and all hazard assessment*. National Fire Protection Association.
- Wilson, H., & Laurent, C. (2014). *Rooftop solar PV & firefighter safety*. Meister Consultants Group.
- Wirth, Harry. (2015). *Recent Facts about Photovoltaics in Germany*. Fraunhofer ISE. Retrieved from <https://www.ise.fraunhofer.de/en/publications/veroeffentlichungen-pdf-dateien-en/studien-und-konzeptpapiere/recent-facts-about-photovoltaics-in-germany.pdf>
- Worcester Fire Department. (2014). *Solar Power Systems: Firefighter Safety and Emergency Response*. Unpublished Internal Document.
- WPI IQP Installer Survey. (2016). [Personnel survey]. Unpublished raw data.
- Zipp, K. (2015). What is the best type of battery for solar storage? Retrieved from <http://www.solarpowerworldonline.com/2015/08/what-is-the-best-type-of-battery-for-solar-storage/>

Appendix A: Interview Consent Form

INTERVIEW CONSENT FORM

We are a research team working in conjunction with the Alternative Technology Association to gather information about firefighter protocols regarding solar PV systems and the effectiveness of the rooftop DC isolator switch. We would like to ask you a few questions targeted towards your experience in encountering fires with solar PV system installations.

Please note that you are not required to answer any of these interview questions. By signing this document, you agree to be interviewed and allow consent for the information provided to be used for this research project. However, the information provided during this interview will be kept confidential and anonymous.

Participant Signature

Date

Printed Name

Appendix B: Interview Questions for Fire Services Personnel

Name:

Organisation:

Job Title:

General Experience/Practices:

What is your general experience regarding the presence of solar PV system installations on buildings?

Have you personally encountered a fire in a building equipped with solar PV systems?

What are your standard on-site procedures for building fires? What processes do you take to assess the environment? How do you isolate the electricity to the building?

What steps do you additionally take when approaching a building fire with solar panel installations? Did you handle this fire differently from a building without solar panels?

What training, either in written or video format, has been provided on how to safely handle solar PV systems during a building fire?

Have you encountered primarily on-grid/off-grid systems? Do you have any knowledge about battery storage systems?

Additional Risks of Solar PV Systems During a Fire:

Did you have any safety risks/concerns specifically related to the solar PV panels during a fire?

Are you familiar with the different components of a solar PV system? From your experience, have any of the solar PV system components been identified as a causative agent or ignition factor for fires?

Rooftop DC Isolator Component:

Are you familiar with the purpose of the rooftop DC isolator switch?

Have you ever utilised the rooftop DC isolator switch? Why or why not?

Is the use of the rooftop DC isolator switch included in your standard operating procedures?

Do you believe the rooftop DC isolator is a vital component of system PV systems? What benefits and/or risk do they add to operational personnel?

Appendix C: Survey Questions for Solar Installers

Survey for Australian Solar System Component Installers

Contact Number

Experience

- 1 to 5 years
- 6 to 10 years
- 11 to 15 years
- 15+ years

Primary Area of Installation

- Melbourne
 - Victoria
 - ACT
 - NSW
 - QLD
 - NT
 - WA
 - SA
 - TAS
-

What is your primary field of expertise?

- Residential Systems
- Commercial Systems
- Larger Systems (Solar Farms, etc.)
- Other

Rooftop DC Isolators

	0 (Lowest)	1 (Low)	2 (Neutral)	3 (High)	4 (Highest)
How effective do you believe rooftop DC isolators are?	<input type="radio"/>	<input type="radio"/>	<input type="radio"/>	<input type="radio"/>	<input type="radio"/>
How much benefit do rooftop DC isolators add?	<input type="radio"/>	<input type="radio"/>	<input type="radio"/>	<input type="radio"/>	<input type="radio"/>
How much risk do DC rooftop isolators add?	<input type="radio"/>	<input type="radio"/>	<input type="radio"/>	<input type="radio"/>	<input type="radio"/>

What benefits do rooftop DC isolators present?

What risk/safety concerns do rooftop DC isolators present?

Do you have a preferred brand of rooftopDC isolator that you have installed? If so, please elaborate

Yes

No

Have you noticed a variation of quality the rooftop DC isolators? If so, please elaborate

Yes

No

Have you had any customer complaints about rooftop DC isolators malfunctioning

Yes

No

If you answered yes to the question above, how many complaints have you heard and why types of complaints?

Are you aware of the rooftop DC isolator switch manufacturer recalls?

- Yes
- No

Beside rooftop DC Isolators, are you aware of any other components of a solar PV system known to be the ignition factor of solar related fires? If so, please elaborate.

Have you had any experience/any opinions on battery storage installs for solar systems? Do you have any comments about this technology?

Additional Notes

Powered by Qualtrics

Appendix D: Interview Questions for ACCC

ACCC Questions:

How are these regulations enforced?

What is the certification test process for the rooftop DC isolators?

How do you determine if a rooftop DC isolator brand has failed the certification test?

What factors are used to determine product recall?

What do you find to be the main reason for product recalls?

Do you have any statistical data on the number of recalls and reason for recall?

Who enforces that the products be replaced after the recall? Is this up to the individual homeowners or is this enforced by the company?

Appendix E: ATA Fact Sheet - Solar PV & Fire Risks

Introduction

With approximately 4 million Australians living under a solar roof, solar PV systems are now a common renewable technology being utilised by consumers. Although there has been a recent decrease in the number of annual installations, the solar industry is still growing.

Solar PV systems provide an alternative source of energy to support the electrical needs of a family or business. The Alternative Technology Association has collaborated with a research team from Worcester Polytechnic Institute (WPI) to assess fire risks associated with solar PV installations. Some of the risks include electrical shock, faulty installation practices, and deterioration of solar components over time. Below are suggestions of how you as a homeowner can help mitigate these fire risks.

What can I do as a homeowner to mitigate fire risks of my solar PV system?

Ensuring your solar PV system is properly maintained can reduce fire risks. You should take precautionary steps and visually inspect your solar PV installations at least once a year. However, you should not put yourself at risk to inspect your system. Visual inspection of the panels includes checking for debris build-up on or around the panels. If the roof is accessible, removing debris and cleaning the panels would be beneficial for the system.

In addition, electrical output of the system should be monitored monthly. The display unit in the inverter shows the output produced by the PV system. On a sunny day, your system should be producing an electrical output of approximately 80% of its total capacity. For example, a 5kW solar PV installation should have a solar electrical output of approximately 4 kW on a sunny day. If the system output is significantly below this threshold value on a standard sunny day, it is advised that you schedule an inspection of the system. Accredited installers note that continuous low electrical output usually correlates to a problem in the solar PV system. Monitoring monthly output may allow you to identify minor issues before the issues develop into fire risks.

Lastly, contact your accredited installer to perform professional maintenance checks once every five years. Although solar PV panels have a twenty-five year standard warranty, some components of the solar PV system have a shorter lifespan. Specifically, the rooftop DC isolator has a warranty of approximately eight years. Therefore, homeowners should look into replacing some components of their solar PV systems every five to eight years.

What options are available to manage my solar PV system and make sure it is running efficiently?

Two alternative options can increase the efficiency of your solar PV system. These components are DC optimisers and microinverters. Both Direct Current (DC) optimisers and microinverters are installed behind each panel in an array to maximise the overall efficiency of solar PV panels.

DC optimisers utilise an efficient DC-to-DC conversion by using maximum power point tracker technology. This technology tracks and maintains the maximum power of each module in the array. A solar PV array with DC optimisers can raise the total power output of the array by as much as 25%. Microinverters convert the DC electrical current produced by the solar panels into AC electrical current that is utilised by household appliances. With the use of microinverters all DC wiring in a typical solar PV system is eliminated. Both microinverters and DC optimisers allow consumers to remotely monitor their systems via their smartphones and/or laptop.

What should I do if my solar PV system catches on fire?

In the case of a fire, immediately evacuate the premises and call 000 for assistance. Once fire services personnel arrive on scene, they will perform a general assessment. Firefighters will turn off all electrical input at the main switch board to cut off the electrical supply to the house. Additionally, most standard procedures require firefighters to switch off the inverter and the AC isolator from the solar PV panels before putting out the fire.

What are some precautionary actions that I can take to lessen the risk of my solar PV system catching on fire?

Precautionary actions should be taken to avoid potential hazards interfering with firefighter operations. Labelling specific components provides emergency services personnel with important knowledge in the event of an emergency. The AS/NZ 5033 code requires that the inverter, switchboard, meter box, and low voltage fuse be properly labelled with the appropriate signage. We recommend that homeowners update the labels on their solar PV system to meet the requirements of the newest version of the standards. This allows visual awareness for homeowners and their families and greatly aids emergency services arriving on scene.

Additionally, we recommend that you ask your installer for a wiring diagram and/or information about routing of wiring throughout your home. Any wiring between your solar PV panels and the inverter carries DC current. Presently, there is no way to detect DC current with instruments. Not knowing where DC wiring is placed in your house greatly increases the

risk of electric shock to firefighters, electricians, or solar installers working with the system. A diagram of this potentially dangerous wiring can also greatly aid emergency services in the event of an emergency.

What should I do after a fire?

Schedule an appointment with your electrician or solar installer to check for potential damage to the system. A licensed electrician or accredited installer must assess the condition of the solar PV system and electrical wiring to turn on electrical power fed into the house.

What should I do in case of a flood to ensure that I am safe?

Floods are a major safety concern for homes with solar PV installations. Even though the solar PV system may be turned off, floodwater that comes into contact with the panels can transmit electrical shock. To decrease risk of electrocution, the PV system should be turned off at the inverter before a flood. Following a flood, you should contact an accredited installer or an electrician to check the system for any electrical faults.

What should I do if my panels are damaged after a severe storm?

After a severe storm, you should contact an installer or an electrician to assess the condition of your solar PV system. Damaged solar PV systems have increased electrical and fire hazards. If a damaged solar panel comes into contact with a conductive surface, the electrical charge can travel up to eight meters from the point of contact, putting unsuspecting individuals at risk. To re-connect your PV system following a natural disaster, you should contact a licensed electrician or an accredited installer.

How can I find out about product recalls for my solar PV system?

It is important to be aware of product recalls and the brands of your solar PV system components. The Australian Competition and Consumer Commission (ACCC) is a regulator of consumer products. If a product is an electrical hazard, the ACCC issues a product recall. Current product recalls for solar PV systems can be found on the ACCC website (<https://www.accc.gov.au/search/accc-funnelback/rooftop%20DC%20isolator?filter=0%3A%20Recalls>) or the Clean Energy Council website (<https://www.solaraccreditation.com.au/products/product-recalls.html>).

What should I do if the product I have is recalled?

Immediately notify your solar installer. After filing product recall paperwork, the accredited installer can remove the recalled product. You will either receive a replacement product or a refund from the manufacturer of the component.

These statements were thoroughly researched by the ATA Project team in the report, *Fire Safety of Solar Photovoltaic Systems in Australia*.



The Alternative Technology Association is a not-for-profit organisation that encourages people to live sustainably in their homes and communities.

Appendix F: ATA Fact Sheet - Battery Storage Systems

Introduction

With one in every seven households in Australia having a solar PV installation, storage batteries are expected to impact on-grid systems. Storage batteries further drive down electrical costs for homeowners. As electrical costs can be rather expensive (20-30¢/kWh) and steadily increasing, homeowners with solar PV systems can benefit from the solar energy generated from their solar PV system.

Feed-in tariffs are set by state governments to allow the public to sell any excess electricity back to the grid for profit. Current open feed-in tariffs range from 5-25¢/kWh across Australia. Some homeowners are also still taking advantage of past feed in tariffs from 2011 and 2012 that ranged between 44-60¢/kWh. At the end of 2016 feed-in tariffs in Victoria, South Australia, and New South Wales are slated to close to new applicants and be replaced by lower feed in tariffs. Lower feed-in tariffs are expected to promote purchases of storage battery systems to be integrated to on-grid systems allowing homeowners to store electricity for personal use. The Alternative Technology Association has collaborated with a research team from Worcester Polytechnic Institute (WPI) to assess risks associated with on-grid battery storage systems and suggestions for how you as a homeowners can mitigate these risks.

Things to Be Aware Of With Storage Batteries

Some storage battery designs, such as lithium ion and flow batteries, are relatively new in the solar PV industry. As a result, standards have not been issued for the different storage batteries. The CEC and Standards Australia are drafting standards for installation and training programs specifically for storage batteries as this technology becomes more prominent.

What can I do as a homeowner to mitigate risks posed by my battery storage system?

In order to reduce risks to fire personnel and yourself, in the event of a fire, make sure your battery storage system is clearly labelled, visible, and is regularly maintained by monitoring the output of the system. This allows fire services personnel to quickly identify any potential risks associated with storage batteries if a fire occurs in your home. Maintaining your system is a key element to reducing risks to yourself and your home and help you to recognise if problems are occurring with your system.

If there is something wrong with your system, contact your installer immediately to assess the issue. An ongoing problem can harm your system and elevate the risk of shock or fire.

Below are some questions to ask your installer when inquiring about storage battery systems:

Experience:

Do you have any prior experience installing battery storage on-grid systems?

If not, what is your general background with solar PV installations?

How many battery storage and solar PV installs have you completed?

How long have you been installing storage batteries with solar PV systems?

Which type of battery do you recommend? Why?

Have you received consumer feedback on these systems? If so, what has it been?

Warranties:

Are there any warranties that come with battery storage systems?

Do you provide a warranty on the system installed?

Additional Inquiries:

Where is the best location for my storage battery system?

Where will the wires connect from my battery storage unit to the solar PV system?

If problems arise with the system, what services will you provide to address them?

Is maintenance required for the system? If so, how often?

In case of an emergency, is there a manual way to turn off/disconnect the battery storage unit?

These statements were thoroughly researched by the ATA Project team in the report, *Fire Safety of Solar Photovoltaic Systems in Australia*.



The Alternative Technology Association is a not-for-profit organisation that encourages people to live sustainably in their homes and communities.

Appendix G: ATA Fact Sheet - Support for Rooftop DC Isolator Mandate Removal

Introduction

With approximately 4 million Australians living under a solar roof, solar PV systems are now a common renewable technology. Each year, approximately 1.5% of residential house fires are caused by solar PV systems (Figure 1). Some individuals have proposed that a majority of solar-related fires can be linked to the rooftop DC isolator component of the solar PV system.

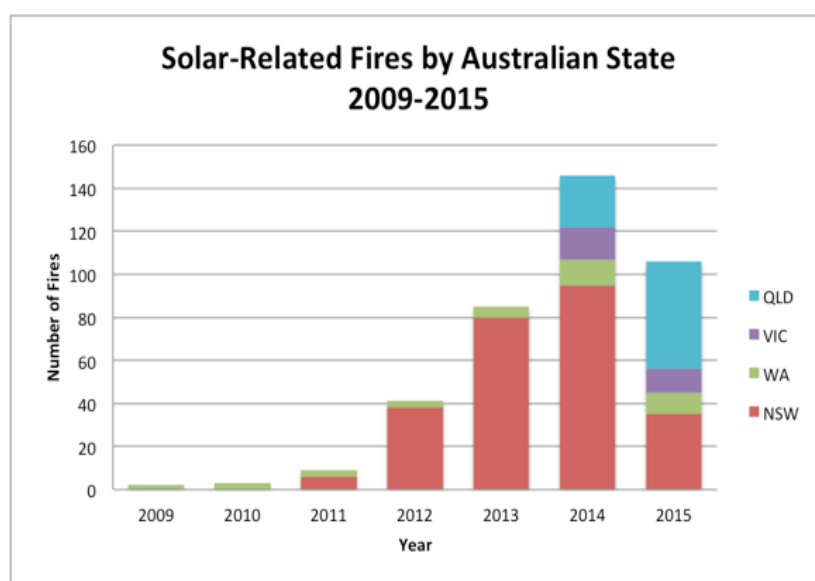

Figure 1: Solar-Related Fires in Australia from 2009-2015 (Data Source: AFAC)

Solar PV systems provide an alternative source of energy to support the electrical needs of a family or business. The Alternative Technology Association has collaborated with a research team from Worcester Polytechnic Institute (WPI) to assess the risks of the rooftop DC isolator switch.

Background

Rooftop DC isolators were proposed by some emergency services as an additional point of isolation for DC current generation on a solar PV system. This isolation switch provided an option to shut off electrical current from the solar panels supplied to the building. However, some individuals have questioned the effectiveness of the rooftop DC isolator component. Statistical data were retrieved from the Australian Incident Reporting System database. In addition, responses were collected from various informed sources involved with the rooftop DC isolator, including accredited solar installers and firefighters.

Results & Discussion

*Aggregate data from AFAC's Fire Investigation Network
Fire & Rescue New South Wales*

From the retrieved statistical data, solar-related fires account for approximately 1.5% of the average annual reported fires. Out of the recorded solar-related fires from 2009 to 2015, the highest known causative agent was determined to be an electrical component of the solar PV system. Although these data do not specifically identify the rooftop DC isolator component, 19% of solar-related fires are caused by either an isolator, inverter, or switchboard malfunction (Figure 2). Aggregated data from the causative agents in Western Australia showed that fifty percent of recorded fires were directly linked to the rooftop DC isolator, however, further research should be completed to support this claim due to the small sample size (Figure 3). In addition, solar-related fire data was collected from Fire & Rescue New South Wales (FRNSW) for metropolitan NSW (Figure 4). Out of the 221 solar-related fires responded to by FRNSW from 2011-2015, 38% of the fires were caused by an isolator. Informed sources at FRNSW attributed a majority of these isolator-related fires to rooftop DC isolators.

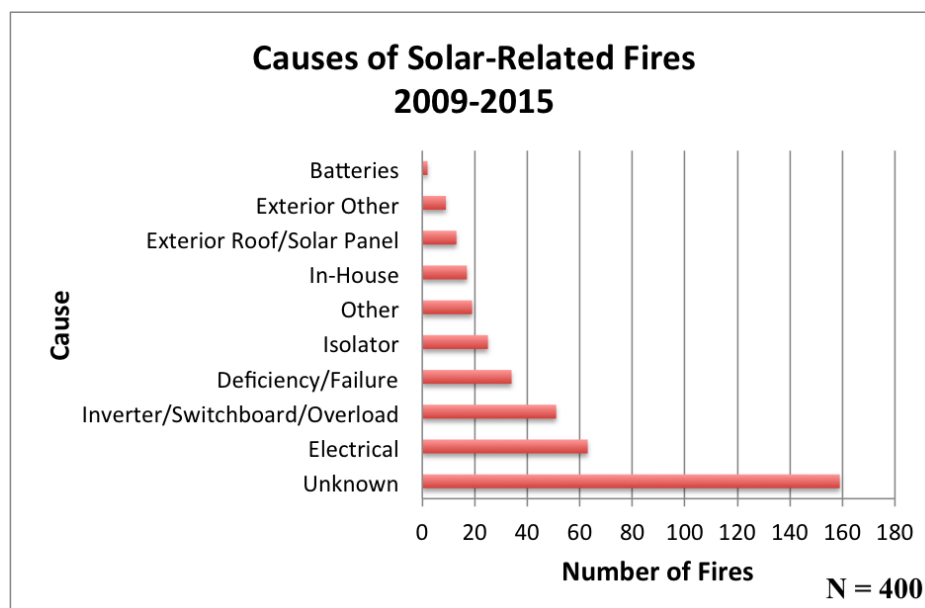

Figure 2: Causes of Solar-Related Fires in Australia (Data Source: AFAC)

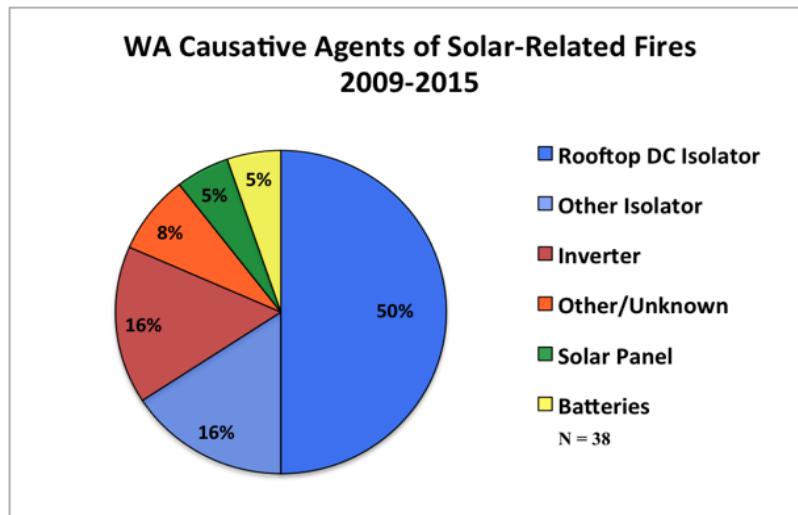

Figure 3: Causes of Solar-Related Fires in WA (Data Source: AFAC)

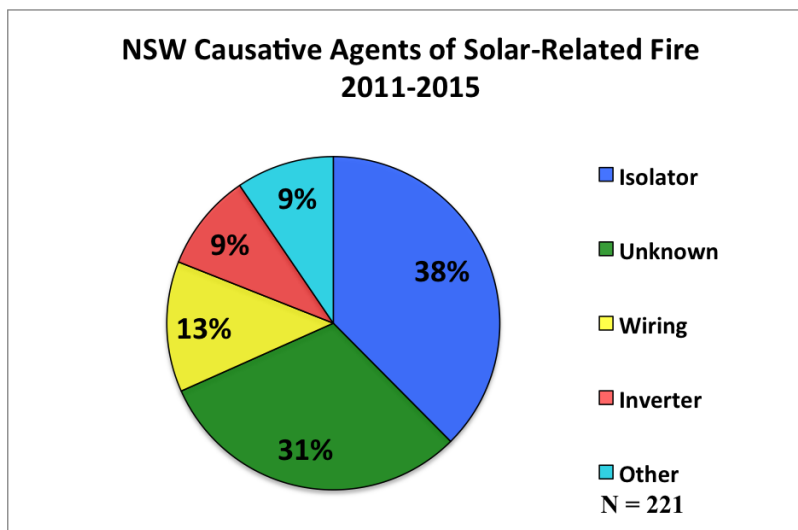

Figure 4: Causes of Solar-Related Fire in NSW (Data Source: FRNSW)

Solar Installer Survey Responses

Twenty-five surveys were completed by solar installers from across Australia. Approximately sixty percent of the solar installers surveyed indicated that rooftop DC isolators are a primary cause of solar-related fires in Australia (Figure 5).

Additionally, eighty-four percent of solar installers responded that a rooftop DC isolator contributes added risks to the solar PV system (Figure 6). Factors such as harsh weather conditions lead to the breakdown of the system, which can increase the fire risk of the component. More than half of the respondents identified water ingress as one of the leading problems with DC isolators. Infiltration of water into the component can cause circuit shorts and increased fire risks.

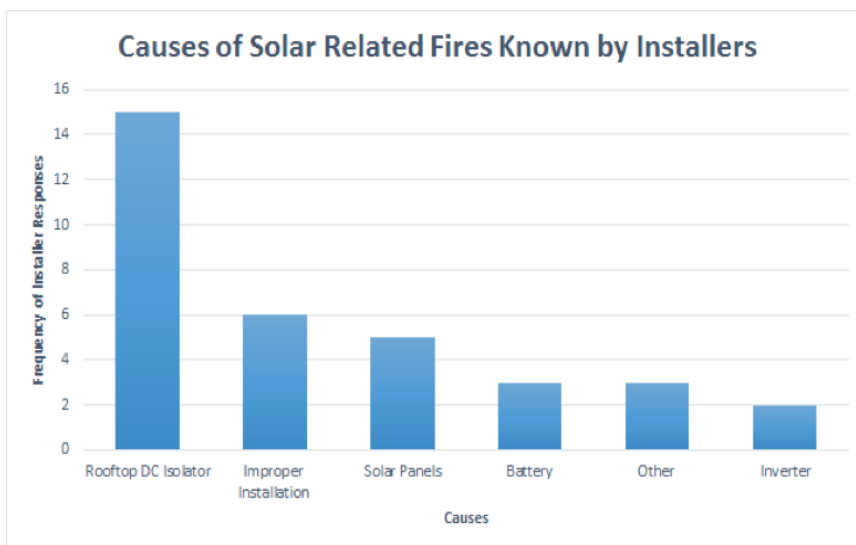

Figure 5: Causes of Solar-Related Fires Known by Installers
 (Data Source: WPI IQP Installer Survey)

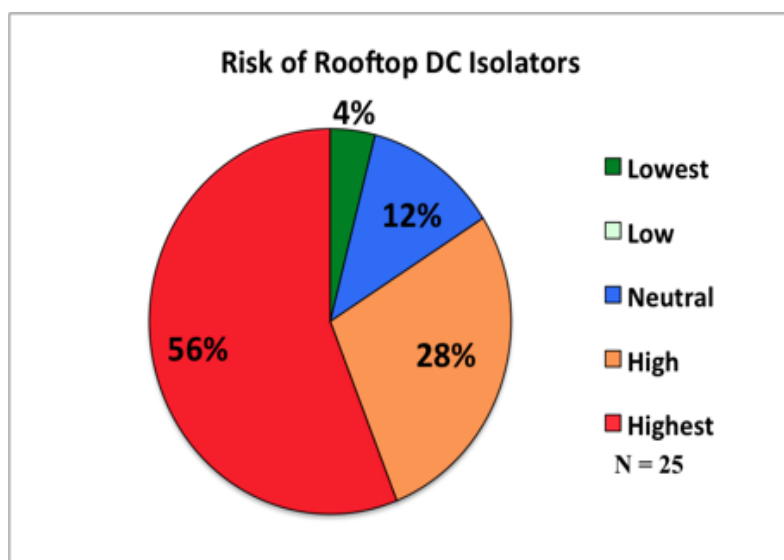

Figure 6: Risk of Rooftop DC Isolators Results
 (Data Source: WPI IQP Installer Survey)

Firefighter Standard Operational Procedures

The rooftop DC isolator was proposed for firefighters as a point of isolation of DC current from the solar panels to the inverter. Documented standard operational procedures (SOPs) were obtained from four fire services in four different Australian states. It was inferred from these SOPs that the rooftop DC isolator switch is not utilised by two fire services and two fire services' SOPs stated that the rooftop DC isolator is utilised only as a last resort.

Conclusion

From our findings, the rooftop DC isolator elevates the risks associated with solar PV installations. This component is recorded to be one of the primary causative agents of solar-related fires from the statistical data. Solar installers stated that the rooftop DC isolator adds more risks than benefits to the system. Lastly, interviews and documentation provided by firefighters disputed the use of the rooftop DC isolator as an emergency shut off switch to further isolate DC current. Based on the supporting information collected, removal of the rooftop DC isolator may reduce the risks associated with solar PV systems. In conclusion, it would be beneficial for authorities to remove the rooftop DC isolator mandate.

These statements were thoroughly researched by the ATA Project team in the report, *Fire Safety of Solar Photovoltaic Systems in Australia*.



The Alternative Technology Association is a not-for-profit organisation that encourages people to live sustainably in their homes and communities.