

**SUNBLOCKS:
DERIVING A STACKABLE SOLAR PANEL SYSTEM DESIGN
FROM HISTORIC UNDERPINNINGS**

A Major Qualifying Project Report

Submitted to the Faculty

of the

WORCESTER POLYTECHNIC INSTITUTE

In Partial Fulfillment of the Requirements for the
Degree of Bachelor of Science

By

Maximilian Theodore Kaiser

April 26, 2012

Professor M. David Samson

Professor Dominic Golding

Table of Contents

| | |
|--|----|
| What is the Major Qualifying Project?..... | 3 |
| Abstract..... | 3 |
| Acknowledgements..... | 4 |
| Chapter 1: Introduction | 5 |
| 1.1 Goals & General Tasks..... | 5 |
| 1.2 Problem Statement and Motivation | 6 |
| 1.3 Objectives & Methodology | 8 |
| 1.4 Design Tasks & Constraints | 10 |
| Chapter 2: Design..... | 11 |
| 2.1: Design Chapter Overview..... | 11 |
| 2.2: Design Description | 11 |
| 2.3: Virtual Model | 12 |
| Chapter 3: Why Was the Glass Block Chosen? | 13 |
| 3.1 The Profundity of the Glass Block Medium..... | 13 |
| 3.2 Aesthetic Lifespan of the Glass Block..... | 13 |
| 3.3 Iconicity and the Glass Block..... | 14 |
| 3.4 Drawing Public Attention Via the Glass Block..... | 15 |
| 3.5 Why Not Plastic? | 15 |
| 3.6: Functional Advantages of Using Glass Block..... | 16 |
| 3.7 Trustworthiness and Honesty Relating to Glass | 17 |
| Chapter 4: The Integration of Industrial Materials into Modern Architecture..... | 19 |
| 4.1 Research Overview..... | 19 |
| 4.2 The Rise of Industrial Materials in Aesthetic Environments: 1880-1914..... | 20 |
| 4.3 Post-War Modernism for Consumer Culture: 1919-1928..... | 40 |
| 4.4 Modernism and Mass Culture During the Depression: 1929-1945 | 46 |
| 4.5 Mass-Production in Domestic & Industrial Architecture: 1945-Present | 52 |
| SunBlocks Design Model | 63 |

What is the Major Qualifying Project?

The Major Qualifying Project, or “MQP”, is the capstone graduation requirement for all undergraduate students enrolled in four-year baccalaureate programs at Worcester Polytechnic Institute. This document is the final compilation of the work of one student completed in fulfillment of the requirements set forth by the Institution which must be completed for consideration for graduation. This particular project was designed, organized, proposed and completed by the student. It was developed specifically to complement the unique academic areas of the Industrial Design individualized major program which the student developed.

Abstract

Glass has been a favored architectural medium of modern times. Growing concern for the environment and a subsequent embracement of greener building habits has encouraged greater use of glass both as a light source and an insulator, among other applications. Rising interest in glass has evoked technological developments in glass and glass products aimed at an increasingly green contemporary society.

This paper presents a methodological theory for developing a solar cell-containing glass block which can be interlocked with other identical units to form a power-generating wall, floor or barrier in a given structure. This paper explores historical developments in industrial design and architecture after 1890 and applies these findings to the development of the glass block design.

Acknowledgements

I would firstly like to thank Dr. M. David Samson, Associate Professor of the History of the Visual Arts and Architecture at WPI, for his profound dedication to guiding me in my research efforts throughout the course of this project. I would also like to thank Professor Samson for instilling in me the enthusiasm and background necessary to gain the most from a lifelong passion for the arts.

I would also like to extend my deep gratitude to Dr. Dominic Golding, Professor of International Studies at WPI, for offering his valuable insight on the organization of my research findings. I would like to thank Professor Golding for providing me with a wise and logical perspective that enabled me to better-tailor my written thoughts into coherent, scholastic statements.

I would like to thank my close friend, Sean M. Reynolds, artist and glassworker, for teaching me about the nature and diversity of one of the most beautiful natural substances known to man. I want to thank Sean especially for encouraging me to pursue the exploration of the benefits of glass as a structural medium.

I would like to thank my loving relative Joan E. Kaiser, a leading expert and historian on the Sandwich Glass Industry, for inspiring me to probe the deep and complex nature of man's relationship with manufactured glass. I would also like to thank Joan for inspiring me to investigate the trends and inconsistencies which describe the historical character and importance of mass-produced glass artifacts in America.

Lastly, I would like to thank Professor Robert Norton, Professor M. David Samson, Professor Chris Brown and Dean Rick Vaz for supporting me in my passionate endeavor to develop an individualized major program to study the art and science of Industrial Design at WPI. I will be forever grateful for your efforts.

Chapter 1: Introduction

1.1 Goals & General Tasks

The overarching goal of this project was to gain knowledge and experience in research and design in order to improve the practical skill set necessary for enacting effective industrial design procedures in the professional setting.

Chiefly, this goal was achieved by exploring the possibility of and potential for a new product design based on knowledge and information gained through research efforts on post-1890 manufactured objects and related topics in architectural history. The test case which was developed for this project was the invention of a glass block solar panel device that would be attractive enough to serve as an integral ornament in architecture while maintaining the benefits of solar technology. The conclusions drawn from research the efforts served as a guide and as inspiration to develop a speculative outlook for the product design regarding the functional and aesthetic values of the proposed design.

The goal of the design portion of this project was to work incrementally from the incubatory stages of idea conceptualization on through to the drafting phase of the product design process while applying findings from the research and adjusting the developing design accordingly. Ultimately, a final design solution was developed which satisfied the original design criteria of creating a functional architectural ornament capable of adapting to different types of architectural styles.

1.2 Problem Statement and Motivation

A growing interest in alternative energy has resulted from a combination of rising energy costs and increasing environmental concern. Recent technological developments in green appliances have begun to make it feasible for homeowners to purchase green devices capable of generating clean power in the typical home setting. However, the high costs associated with purchasing and installing these devices deters many. This is particularly true for solar products.¹

There are very few solar options which currently appeal to typical homeowners. In addition to the high retail and installation costs of photovoltaic (PV) solar panels, there are a number of reasons for consumer discouragement. Some of these include the inadaptability of PV panels to certain building styles, their obvious and often undesirable technical appearance (which bans them in many historic locations), the unpredictability of inclement weather, and the difficulties involved in finding qualified technicians to service the panels. Another problem that plagues conventional PV panels is that there is a great deal of mystery surrounding them: most people probably could not say exactly how they work or what materials they are made of. Despite government incentives aimed at helping people finance PV panels, very few people take advantage of state and federal grants which would enable them to own solar equipment. Overall, little impact has been made on encouraging more homeowners to install solar devices. It is apparent that many people see the drawbacks of PV panels outweighing the potential benefits. The bottom line is that people see a risk in investing in solar technology.

The main problem with the current domestic solar market in the US is that there is really no such thing.² What exists is an ad hoc group of mom and pop distributors and small-time manufacturers dealing directly with homeowners, so any market base which might exist is very difficult to define. Energy experts and enthusiasts agree, however, that there is a foundation for a domestic PV market and that it has great potential.³ In seeking to expand this market base,

¹ Borenstein, Severin (January, 2008). The Market Value and cost of Photovoltaic Energy Production. *Center for Energy Studies Working Paper Series*. University of California Energy Institute; University of California, Berkeley. CSEM WP 176, pp. 1. Site: <<http://www.ucei.berkeley.edu/PDF/csemwp176.pdf>>.

² SunShot Vision Study. (February, 2012). US Department of Energy. Pp. 27. Site: <http://www1.eere.energy.gov/solar/pdfs/47927_chapter2.pdf>.

³ Reijenga, Tjerk H. "22: PV in Architecture". *Handbook of Photovoltaic Science and Engineering*. 2003 John Wiley &

manufacturers of solar panels need to increase their appeal to the homeowner audience and they must do so by creating products which are more versatile and adaptable to different styles of architecture and more appealing to different tastes and decorating preferences.

There is no solar company in existence that has created an iconic architectural product in an innovative style such that its corporate brand is synonymous with solar technology. Solar technology has been widely available to homeowners since the 1970's and with the exception of PV popularity in a handful of wealthier coastal towns, it is rare to see a row of homes with solar panels on their roofs—in fact, it is uncommon, in most parts of nation, to see PV solar panels on a roof at all. There isn't currently a company whose name is synonymous with the potential for the industry because there is not an appealing niche in the PV market to warrant branding and advertising.

There has not been enough care taken in designing solar panels that attract the interest of typical homeowners. The solar panels which are currently on the market are fashionably green and are economically smart for investors, but overall, they are not green or economical enough to widen the PV market base. If the target buying group for solar panels is going to expand, then the aesthetic of the panel needs to be changed and the renovated panel needs to be marketed accordingly—it needs to be representative of something new and innovative. Above all, this new panel needs to be symbolic of green technology that everyone can afford financially and afford to live with aesthetically. The new panel has to be an icon that says, “everyone can afford to be financially and environmentally smart”.

1.3 Objectives & Methodology

Specific objectives for this project were created to meet the goal of developing a research-based design. Accordingly, the main objective of this project was to conduct research on successful product designs and modes of architecture, applying findings to the development of a new solar product. To achieve this, a historical analysis of successful, relevant designs from the post-1890 era was conducted in order to gain inspiration for designing an effective, attractive solar product for present-day American consumers. This timeframe was chosen because it has been characterized by an increasing dependency on manmade materials and industrial objects. This is something that must be taken into consideration when designing any product aesthetic geared for the consumer market. It must be understood which materials are desirable and which are not, identifying concurrent design styles that make specific materials more desirable and versatile in the marketplace.

Specifically, research focus areas concentrated on architectural and product designs that encouraged (and in some cases discouraged) user interest and ones which caused subsequent trends and changes in culture. Landmark innovations were studied as well as the design theory aspects that were used in developing those innovations. Combined, these aspects served as a model for the project design by providing insight on specific design aspects that have made certain objects profound. Additionally, this focus was meant to aid in developing ways that the project design might be able to encourage solar education by appealing to a potential market that is uninformed about and/or cannot afford conventional, roof-top solar arrays. By gaining deeper understanding of why people have chosen to favor certain design styles and materials, it became apparent that the project design aesthetic might be able to encourage enthusiasm for solar devices by bringing accessible photovoltaic (PV) technology to a market that may not have previously had many practical or decorative outlets for it.

Technically and practically, the underlying objective for this project was to use knowledge of existing product designs and architectural styles to invent a simple photovoltaic device which the user would be capable of installing and operating. It was determined that the device should be able to demonstrate its basic internal function upon observation, thus encouraging the observer to gain more passion for and knowledge of solar technology.

Because the project design intended to target the general home-owning consumer audience, design constraints were developed to aid in concentrating on functional and aesthetic values which would cater to the lifestyle and interests of the average American, specifically homeowners in the working class. It was therefore necessary to investigate ways that a PV product design could broadcast the economic benefits of PV power-generation, and not just the environmental benefits, according to the theory that a maximum return on a small initial investment (and one which provides user satisfaction at a substantially lower cost than conventional PV arrays) could attract typical US homeowners.

The project design needed to be capable of being incorporated into diverse architectural styles and would need to be versatile and capable of being installed in a large number of locations with no modification. Above all, the project design needed to be iconic. That is, it had to stand out as a recognizable object, but still be able to be integrated into different types of structures while maintaining its outward appearance. Aiming for symbolism, the possibility of creating a unique product which would be easily identifiable to the public was explored in order to develop theory on how the project design might be able to become visually representative of money savings, environmentalism and creative, modern taste. This was presumed to be achievable through the design of a product which used a unique, but architecturally adaptable aesthetic capable of catering to different decorative preferences.

1.4 Design Tasks & Constraints

The following focus areas were laid to serve as points of consideration for the student to take into account during the research and design components of the project. The intent of these points was to aid in the refinement of the design in order to make it accessible to a maximum number of target homeowners with differing decorating tastes and user needs.

- **Aesthetic Design (based upon historical successes and failures of similar products)**
 - Marketability (based on success of products with similar design traits)
 - Architectural Integration
 - Within Homes
 - Within Businesses
 - Within Industrial Facilities
 - Business Desirability
 - Consumer Desirability

- **Design for Usability**
 - Ease of Installation
 - Ease of Reparability
 - Design for Sustainability and Recyclability

- **Design for Functionality**
 - Embracing Multiple Uses
 - As a Natural Light Source
 - As a Renewable Energy Resource
 - As a form of Alternative Insulation

- **Design for Manufacturability**
 - Intuitive Assembly
 - Optimized Assembly Procedure
 - Using Post-Consumer Waste in Manufacture

- **Design for Economic Feasibility**
 - Mitigating Manufacturer Costs
 - Minimizing Consumer Costs
 - Cost of Product
 - Cost of Installation

Chapter 2: Design

2.1: Design Chapter Overview

The following section describes the plans developed for the original Glass Block Photovoltaic innovation entitled “SunBlocks” which was developed specifically for the design portion of this project. As the project focused on the idea of using historical hindsight to develop a new design, attention was given to many variables which have influenced the design of relevant architectural components and consumer products, specifically those which have involved the integral use of industrial materials. The retrospection gained from research efforts and the according conclusions, theories and speculations drawn from the findings was the major influence for and defense of the final design.

2.2: Design Description

The SunBlocks system is comprised of a series of square, Lego®-like glass blocks which are identical in size, shape and function. The blocks are stackable and are intended to be used in architectural applications, taking the place of conventional walls and windows around the home or office. The individual units can also be laid upon the ground to form a walkway or patio, or can serve collectively to form a standalone structure such as a barrier or a self-sustaining greenhouse.

The interior frontal wall of each hollow block hosts a rectangular photovoltaic solar cell mounted in an outward-facing position. Sunlight radiates through the glass façade of the block and onto the cell inside, in turn, generating a viable amount of usable electricity. The units are intended to link to one another via an internal parallel terminal wiring system which allows the bricks to generate cooperative power; the more blocks that are linked together, the more power that can be generated. The maximum power output of each unit should be expected to fluctuate depending

on the amount of sunlight that each block is exposed to. The units are generally capable of generating a power level somewhere between one and five volts with a relatively low current.

The power produced can be used in one or more of the three following options:

1. Can be fed into the power grid infrastructure, reducing the operator's electric bill
2. Can be conditioned and stored in batteries via an intelligent regulatory system
3. Can be used as unconditioned energy to run variable-speed appliances like DC fans

2.3: Virtual Model

The following model depicts an array of six interlocked SunBlocks units. Generally, a purchaser would install many of these units stacked on top of and along side of one another in the typical fashion that architectural glass blocks are commonly arranged.



Chapter 3: Why Was the Glass Block Chosen?

3.1 The Profundity of the Glass Block Medium

Glass has long been a celebrated manufacturing medium in Western society. The specialized tasks involved with forming glass such as casting, molding, sculpting and blowing are notoriously difficult to master. Because of the difficult nature of glass working and the unique properties of glass itself, the substance has been a desirable commodity for millennia. The project design constraints implied the need for a functional architectural component which could also serve as an integral ornament in or around a building. The natural beauty of glass, combined with its durability, lent well to this concept and to the idea of using a glass block as a host for the PV panel. Additionally, the transparency of glass blocks enabled greater versatility of the project design concept because the panel would be mounted internally, lessening the restrictions on how and where the finished device could be placed. As the panel and internal components are sheltered by the thick-walled glass, the proposed design is waterproof, crushproof and scratch-resistant and is also an insulator. It can be used just as easily to build flooring as it could to construct a ceiling or a wall, a concept completely new to the photovoltaic industry. Rather than having a solar panel which is simply an ‘addition’ to an existing structure, the SunBlocks design makes the PV panel a *part of* the structure.

3.2 Aesthetic Lifespan of the Glass Block

Aside from the more obvious structural benefits that the glass block offers, it was chosen as a host for the PV panel because the glass block medium has maintained the same presence in architecture, mostly unchanged, for over a century. Because there is a high potential that SunBlocks will comprise or replace an integral part of a structure (such as a wall in a kitchen, for example), it was important to choose a design style capable of resisting stylistic trends in interior design and architecture, which inevitably change over time. Despite the drastic changes that design preferences underwent during the twentieth century in both architecture and domestic

decoration, the glass block prevailed aesthetically with little alteration to its form and function. While the glass block might not be a staple in most currently-popular design styles, it is still being employed in modern structures. This is important to the idea of permanency—no one wants to replace their kitchen wall with something that will be considered aesthetically obsolete a decade later. SunBlocks are not like wallpaper; they have to remain aesthetically acceptable over time. The glass block has proven itself to withstand the test of time in recent history, so it was a strong candidate for the task of hosting the PV panel.

3.3 Iconicity and the Glass Block

It had been determined that in order to best meet the design goals set forth for the project, the SunBlocks design would benefit from being iconic, that is, representative of ideals that the public can identify and associate specifically with the SunBlocks image. If the final design aimed to achieve notoriety and respectability among homeowners, designers and architects, then it was in the best interest to design an aesthetic which would represent the profundity of the SunBlocks innovation. The project design needed to be iconic in the sense that a single SunBlocks unit could be seen as something more than ‘just a decoration’ or ‘just a solar panel’—it needed to be interpreted as one entity capable of delivering both functional and aesthetic benefits. The SunBlocks unit needed to exhibit an environmentally-progressive attitude while being capable of contributing to the spatial rhetoric of whichever location it might be installed in.

The glass block medium helped to address the challenge of designing a product which could be more universally accepted across a spectrum of contrasting decorative tastes. Its transparent properties remind the viewer that the object is useful as a natural light source and an insulator as well as a creative, decorative, and hopefully ‘unique’ architectural ornament—all of which are traits that are commonly desirable in building design. It was presumed that if the project design was able to achieve these traits, then SunBlocks units would be more likely to gain a reputation as an industry first for being a multifunctional PV architectural device. This reputation was assumed to be a helpful aid in establishing an iconic character for SunBlocks units which could have the potential to be the *original* and *best* way to innovatively integrate PV technology into modern structures. Concurrently, it was believed that this potential could help to gain SunBlocks

a celebrity-like status in which the public identifies the signature design of the units with innovation in a progressively modern world—notably in the areas of practicality, environmentalism, money-savings and architectural creativity.

3.4 Drawing Public Attention Via the Glass Block

The glass block exhibits the rare and desirable characteristics of glass in an unconventional way, and that is why its main purpose is to serve as an alternative to common building materials. The glass block is by nature, an artifact which is intended to stimulate the visual senses. It does so through its unexpected presence. The glass block maintains the unique characteristics of glass while being simultaneously less-conventional than the building mediums like drywall and cinder blocks, which it often replaces. It draws attention either toward the block itself, or to the overall atmosphere, by adding to the spatial environment where it is installed, namely by way of altering the light which encounters it.

The glass block is not as popular today as it has been at other times in past architectural movements and it was determined that this could be advantageous to the goals of the project design, particularly regarding the ideas of teaching about PV technology and encouraging greater use of solar. It was theorized that the unusual outward appearance of the glass block and the effect which it has on the built environment would be likely to draw viewers closer as a result of curiosity. Because glass blocks are not particularly common, it was speculated that in addition to these claims, an abundance of glass blocks in a modern structure might generate additional attention, which could potentially translate into public esteem for the SunBlocks concept if the units are viewed by the public as a new, innovative solution.

3.5 Why Not Plastic?

If cared for properly, glass offers a longer lifespan and generally provides a greater level of satisfaction to the consumer than plastic does. Glass is simultaneously delicate and rugged and the owner is probably more likely to give a glass artifact special attention and take greater pride

in owning it than if it were made from a material such as acrylic. There are modern plastics with optical qualities and aesthetic characteristics nearly indistinguishable from those of glass. However, consumers and designers alike still resort to glass for most cases concerning interior decoration and architectural accent; the substance is integral to modern architectural design. Glass is known for adding presence to a room as well as to the glass object itself, regardless of its specific application as a window, lampshade, drinking vessel, or otherwise. This notion is true for glass artworks as well as for the utilitarian applications of glass such as in glass blocks.

The weight of glass gives the glass block a connotation of permanence. Because the project design is meant to exist as an installed appliance, it is important that SunBlocks are not seen by the public as a 'disposable' item. Similarly, it is important that after the novelty of the design diminishes post-installation, that there is still an appreciation for the units. SunBlocks need to be seen as beneficial contributors to the functional and aesthetic environments in which they are installed, regardless of *when* they were installed. It was theorized that the weight of glass, as opposed to plastic, would be a contributor in gaining this reputation for permanence and longevity. Additionally, the simplicity of streamlined glass products seems to offer a long lifespan for which these types of Modernistic products, such as glass blocks, are considered to be aesthetically acceptable. Also, the ability of glass to resist the elements adds to this, as it makes the material desirable when compared with many modern plastics that fade and mar over time and become less aesthetically-pleasing with age.

3.6: Functional Advantages of Using Glass Block

The use of a glass brick to house the project design's technical components offered many functional advantages to the SunBlocks concept. In terms of functionality, the rigid glass bricks are weatherproof and resistant to everyday wear as well as to unexpected traumas such as flood and fire. The sturdiness of the units allows them to be used in brutalizing applications such as integration into a patio or walkway where foot traffic would compromise the option to install non-ruggedized PV devices.

The diverse applications and variety of potential uses for the bricks give them a substantial advantage over comparably small architectural solar devices such as PV roof tiles and storm shutters, which are confined to specific locations on the home. Similarly, devices like solar roof tiles and shutters do not allow for expansion; once the roof is covered and the shutters have been converted, there is no possibility for further investment unless an extension is built on the home. One of the main key advantages to the SunBlocks design however, is the fact that a power-generating glass block can coexist with other green technologies without competing for prime location space, such as on a roof. While SunBlocks will indeed generate more power in sunnier locations, they can also go where other green appliances cannot. Unlike other small PV devices, the potential applications for SunBlocks are only limited by the homeowner's creativity.

Often times, persons interested in maximizing the power-production efficiency of their homes tend to continue upgrading and expanding upon the amount and caliber of their green devices. For many, this is as much of a hobby as it is a passion. The SunBlocks design allows for virtually infinite expandability, as units can be purchased separately and additions can be made to existing arrays. The versatile design of the blocks allows the user the option to start a new project that is separate from other arrays that might already exist. More importantly, the user does not have to put the units in or on their home if it is not desirable; they could be used to build something like a garden shed or a mailbox post, for example.

3.7 Trustworthiness and Honesty Relating to Glass

While glass has some undesirable traits, the beneficial characteristics which it does exhibit make the substance a superior choice for many applications in the domestic setting. Its reputation for permanency and reliability make glass a trustworthy material, which is an important trait for an architectural medium to have. Additionally, the transparency of glass makes the substance honest because it gives glass a connotation of truth: a clear object has nothing to hide. The transparent blocks offer observers a view into the basic wiring and functionality of a PV panel and this is something which no other solar product currently on the market does. This could

potentially encourage greater curiosity and investment into a new, user-friendly green appliance that users can understand.

In designing the SunBlocks concept, two types of rhetorical mystery were identified. The first type was the mystery of glass as an enigmatic, but desirable substance and this was considered to be greatly beneficial to the project design. The second type of mystery which was uncovered is that which seems to surround technological devices and prevent people from understanding or wanting to look at industrial devices due to the complex and often overwhelming nature of technology. This type of mystery was considered to be malignant in terms of the project design because it contrasts many common ideals regarding hospitality in domestic decoration.

It was determined that a transparent glass block might be an effective deterrent against the overwhelmingly technological presence that an opaque, textured or translucent block might impose on the overall unit. While a translucent block does reveal much more detail about the device to the viewer, it does so in a truthful fashion. The technological innards of the SunBlocks design and the aesthetic nature of the glass block itself make a SunBlock unit visually industrial, but the transparent shell removes the mystery of what is inside the device that enables it to function. The glass block provides truthfulness to the homeowner by giving an honest look at what is being brought into the home. Additionally, SunBlocks deliver this truth through the use of glass, which is something that people are already familiar with architecturally, so this too was believed to bring additional comfort to homeowners, enabling them to accept the design more readily.

Chapter 4: The Integration of Industrial Materials into Modern Architecture

4.1 Research Overview

The twentieth century is the century of the masses:...science, technology, mass locomotion, mass production and consumption, mass communication...[this era embraces] the predominance of architecture and design over the *beaux-arts*, it means the predominance of the city over the small town and the country, and it means the concentration on architecture and design for the masses and on what new materials and new techniques can do for them.

—Nikolaus Pevsner⁴

In both the business and consumer markets, aesthetics play a major role in the desirability of products. To the consumer, the appearance of an object often comes before its functionality and efficiency. This is especially true for objects which are exhibited on a daily basis and are visible in everyday life. It is therefore crucial that any new product design has enough historical relevance to accepted, existing designs so that the design aesthetic is not too overwhelming to appeal to the mass culture.⁵ At the same time, the appearance of a new design needs to be different enough from the norm so that the object has a presence and a character that make it stand apart from competing products. These are critical focus areas for the project design which has to look unique, but also be attractive. The project design has to have an industrial aesthetic that lets viewers know that the object has a utilitarian purpose, yet it also has to be appealing enough aesthetically so that people will consider putting the blocks in high-visibility locations in their homes.

⁴ Nikolaus Pevsner. The Sources of Modern Architecture and Design (1968). Reprint, 1979. Oxford University Press: New York. Pp. 7.

⁵ Tilmann Buddensieg, Henning Rogge et. al.. Industriekultur: Peter Behrens and the AEG, 1907-1914 (1979). Berlin: Gebr. Mann Verlag. 1984 English Translation by Boyd Whyte, Cambridge: MIT Press. Pp. 62.

The subsections of this chapter explore industrial materials as they became integrated into product designs and architectural forms in the post-1880 era. These sections investigate trends in modern product innovation as part of an effort to understand how industrial materials have been successfully integrated into and marketed to become popular and iconic artifacts.

4.2 The Rise of Industrial Materials in Aesthetic Environments: 1880-1914

Toward the end of the nineteenth century, industrial methods began to dominate over hand-crafted production. Automated machining lent itself to an increased use of industrial materials which were strong, practical and easy to manufacture. The introduction of efficient engines and lathes that made industrial machining processes possible also made the marketing of industrially-produced artifacts commercially feasible and economically viable. High quality objects, parts and structural components could be made in quantity; identical products could be mass produced and widely distributed. As a result, industrially produced artifacts and structures became commonplace in western cities by the early nineteen-teens.

Many experimental designs involving the use of glass and metals were created during the two decades preceding 1900, several of these are considered to be landmarks in design history. The early experimentation of industrial mediums is an important to consider concerning the project design because many of the designs which resulted from the efforts arrived with mixed opinion; the designs were not all well-received by the public. The project design aims to achieve maximum acceptance among different decorating tastes and lifestyle preferences, minimizing distaste as much as possible. It is therefore helpful to determine, when possible, which design aspects of these early industrial object designs were well-received and which aspects were not. Present-day homeowners are more inclined to decorate with industrial objects than pre-twentieth century homeowners were, but the average homeowner today would not want a house to look like a factory. Hindsight gained from examining early industrial objects can be useful to the project design to aid in deciding where the lines can be drawn for industrial aesthetics that are desirable, versus those which are not. The project design should not take-away from the 'hospitality' factor of interior decoration.

Before 1900, there was widespread rejection of the large-scale use of industrial materials. The erection of metal structures such as the Eiffel Tower (1889) contradicted the Transcendental and Romantic ideals that many adhered to during the latter nineteenth century. These ideals favored nature over industry and often kept people living in fear of a dehumanized world powered by steel, coal and grease.⁶ It took designers and architects several decades to integrate enough visually-appealing metal structures into society such that the presence of cold, hard, industrial objects would become acceptable. Early industrially-fabricated structures like designer Hector Guimard's Art Nouveau-styled Métro entryways in Paris (1899-1904) were crucial, proving that industrial materials could be beautiful if care was to be taken in deciding how they should look.⁷ This is one point that the project design needs to convey through its design aesthetic: industry can be beautiful if it can relate nature and emotion to industrial productivity in a non-aggressive way. Guimard's work did this through the use of non-linear forms and floral accents which decorated his industrially-produced art works.

In his day however, Guimard was mostly unsuccessful at getting the public to appreciate the balance between industry and nature that he was trying to convey through his works. Some critics viewed Guimard's artistic efforts to reference the natural world through decoration as little more than attempts to employ new, industrial mediums—a reoccurring view which has plagued many modern artworks since then with applied connotations of cheapness, disposability and trendy politics. The project design must strive to avoid this and do so by omitting excessive non-functional decoration which might distract from the more profound design principles which define the overall aesthetic. The project design must make it apparent that the glass block is not an *excuse* to put a PV panel in a new location, but rather the embrace of the PV panel as a productive architectural ornament. The design must be seen a functional decorative artifact that is a solution to the problem of green power production. But, it must *also* be seen as something which seems to offer multitude of other benefits in addition to solving that problem.

While there were a number of artisans working in the Art Nouveau style around the turn of the twentieth century, it is probably the work of Hector Guimard which most directly relates to the project design. In both his outdoor structures as well as in the decorative objects which the artist

⁶ Forty, Adrian. Objects of Desire: Design and Society since 1750 (1986). 2005 ed. New York: Thames & Hudson. Pp. 101.

⁷ Pevsner, Pp. 98-100.

designed, Guimard, along with many other Art Nouveau designers, fought a difficult battle to convince the public that decorative industry was beautiful. While many of Guimard's designs were functional, they were not necessarily functionally superior to those of other artists' designs which used non-industrial mediums—mediums such as wood and stone which the public accepted. Many of Guimard's critics challenged the artist's reasoning for using "ugly" industrial materials to achieve the same task that an acceptable material could achieve—these critics saw the use of industrial materials as a cheap way to avoid taking care and pride in producing something that could be called "art".⁸ This mentality which discouraged industrially-produced artworks followed the opinion of period figures like John Ruskin, who advocated that the artistic process is futile regarding mass-produced factory objects which require no enjoyable labor to produce.⁹ This is something which is very important to the project design because, like many of Guimard's designs, the blocks *will* be produced in a factory. The design aesthetic of the blocks can rely on design variables such as form, color and texture, which can aid to overpower the industrial appearance that many glass blocks and PV panels have. Using aesthetics modifiers such as these are ultimately what did convince the public that industrial objects could be beautiful.

Getting people to purchase and place (or install) industrial objects in their houses in the early twentieth century was an undertaking that took a great deal of energy. What made this achievable, however, was the development of industrially-produced objects representative of the themes that people did want in their homes, which were mainly topics reminiscent of the natural world.¹⁰ Large scale romantically-inspired industrial works of this type were showcased in World's Fairs and in installations around Europe in attempt to convince the public to step into the new age and buy modern, manmade artifacts.¹¹ What ultimately won-over consumers in the beginning however, was architecture, because its grandeur scale was difficult to ignore.

⁸ Andrew Ayers. *The Architecture of Paris: An Architectural Guide*. 2004. London: ed. Axel Menges. Pp. 382.

⁹ Rob Knowles. "Carlyle, Ruskin, Morris: *Work Across the 'River of Fire'*" (Summer, 2001). *History of Economics Review*. Special Issue (No.34). Site: <http://www.hetsa.org.au/pdf/34-A-09.pdf>. Pp. 136-37.

¹⁰ James Grady. "Nature and the Art Nouveau" (September, 1955). From *The Art Bulletin*; Vol. 37, No. 3. Electronic ed. by The College Art Association. Site: <http://www.jstor.org/stable/3047607?seq=2>. Pp. 187-188.

¹¹ Georges Vigne. *Hector Guimard: Architect Designer 1867-1942*. 2003 English Edition by Delano Greenidge Editions LLC, New York. Pp. 17.

The concept of building an artistic environment was especially important to the Art Nouveau movement which was known for balancing architectural design with interior design—both of which were heavily reliant on developing materials and manufacturing processes. This concept lends itself well to the project design, which is capable of being both an outdoor ornament and an indoor decoration when used to form a wall. More importantly, the project design is will be a major industrial component in a modernist environment—something which was very desirable in Art Nouveau design and architecture.

Early industrial materials in architecture effectively demonstrated not only the usefulness and versatility of new materials and machining applications, but also the concept that manmade substances could be turned into aesthetically pleasing artifacts by a strong designer. Historically successful integrations of new mediums in architecture are iconic because they are inspirational and represent innovative personalities and often, bold expressions. Art Nouveau epitomized this concept because it was an attempt to decorate the “undecoratable”; it aimed to produce an aesthetic that would distinguish decorative industrial objects from industrial monotony.

Art Nouveau aimed to use new industrial materials to create iconic designs which were symbolic of modernity and a ‘change in the times’ from old-world Europe into a more cooperative, productive manmade society. The Art Nouveau movement attempted to define an era iconic of industrial creativity rather than mechanized mayhem. This is precisely what the project design must achieve—it has to be symbolic of industrial creativity. If the glass block design can achieve this, then it will be representative of something much greater than simply the glass block or the PV panel alone, it will be an icon symbolic of an era of change from power-grid dependence to green living. Art Nouveau designers fought to exhume the lowbrow, utilitarian connotations from mass-produced manmade products, and they did this by breaking the rules for what were considered to be acceptable uses for industrial mediums. The project design aesthetic must do this in order to prove that even thick-walled glass and silicon chips can be an enjoyable, functional art object which has the capacity to expand creative design within architecture.

Nature is a big book from which we can draw inspiration, and it is in that book that we must look for principles, which, when found have to be defined and applied by the human mind according to human needs”

–Hector Guimard¹²

Hector Guimard’s Paris Metro kiosks are the embodiment of the designer’s desire to use the built environment as a divider between the natural and manmade worlds. The gateway entrances are very much relevant to the project design because they act as barriers between the natural world and the underground subway system which is completely man-made. They are the boundary between the blue sky, trees and grass and the efficient machines below; they are icons representing the thin line between nature and industry. This is what the glass blocks will be if used in place of a conventional opaque wall in a building. The blocks will be the differentiators between natural-world comfort and autonomous manmade industry. Just as Guimard used large sheets of textured glass in the roof-awnings fanning out over the top of his Metro entryways, the project design must use glass to act as a reminder that there is a natural world beyond the barrier. The glass blocks are not meant to be windows, but they need to share the functional aspects of a window which allow people to feel that they are not being contained by a manmade structure (such as a house), even when that is the case.

Guimard studied glass blocks and used them in some of his building designs such as the stairwell in his own Parisian home, which exhibits stairwells of stacked hexagonal translucent bricks interlaced with similar units of contrasting shape and textures.¹³ In his home, Guimard’s use of glass blocks was fundamental and sparing; he did not construct entire walls out of the objects, but rather used them as decorative accents within existing walls. He used them creatively and invented his own design schemes for how they should be arranged and organized. This idea of design adaptability applies to the project design which does not have to follow conventions as far as organization—different types or colors of the blocks could be organized according to the owner’s preference. Guimard’s most celebrated use of glass blocks, and probably the best example of his desire to arrange them creatively, was in the design of his *Castel Béranger*

¹² Guimard, Hector. “An Architect’s Opinion of L’Art Nouveau” (June, 1902). From *The Architectural Record*. Vol. XII, No. 2. Pp. 127.

¹³ Vigne, Pp. 362-63.

(1898), which employed a large number of the blocks with various embossed patterns and design styles.¹⁴

Glass blocks in the late nineteenth century were a very new concept and had not yet established a strong presence in either industrial or domestic architecture. Although there is some dispute over the exact origin of their invention and more specifically, who invented them, it seems fairly evident that the design began with the Swiss glassworker Gustave Falconnier, who developed an efficient method of blowing hexagonal and ovular “briquettes” out of lead glass in the late 1880s.¹⁵ These original units were referred to as “Falconnier Briques” (Falconnier Bricks) or “Verre Falconnier” (Falconnier Glass). They were sold, distributed and marketed by Falconnier’s Glass company and were patented in the U.S. in 1907.¹⁶ The Metropolitan Museum of Art retains several 1886 examples of Falconnier’s early-production uncolored units.¹⁷ The units which Guimard installed in Castel Béranger were Falconnier Briques.

Luxfer, a notable manufacturer of architectural glass products, arrived in the industrial building scene in the late nineteenth century as a producer of prismatic glass tiles. They could effectively diffuse natural light while offering security and rigidity with no maintenance—something which made the tiles popular in factory settings compared to standard, less-durable windows. Luxfer’s original tile designs, referred to as the “Luxfer Prism”, were the basis for the company’s thicker, more durable design which was developed at the turn of the century. These ultimately opened the industrial glass industry to new outlets and glass manufacturers. The Luxfer Prism Company filed 162 mechanical and design patents in 1897 to stake their territory in the developing market. This, among other aggressive business decisions, aroused great investment interest from shareholders and established Luxfer as the period leader in industrial architectural glass.¹⁸

¹⁴ Ian Macky. “Falconnier: *Gustave Falconnier’s Brown Glass Bricks*”. From: *Glassian*. Site: <<http://glassian.org/Falconnier/index.html#FFSBGB>>. Accessed March, 2012.

¹⁵ Macky. “Falconnier: *Gustave Falconnier’s Brown Glass Bricks*”.

¹⁶ “The History of Glass Blocks: *The Origins of Glass Blocks*” (2007). Block Lock Corporation. Site: <http://work.sitedirect.se/sites/vetro/blocklock/index.php?show=63933_SWE&&page_anchor=http://work.sitedirect.se/sites/vetro/blocklock/p63933/p63933_swe.php>. Accessed March, 2012.

¹⁷ Museum of Modern Art, New York. MoMA Collections: Department of Architecture and Design. Site: <http://www.moma.org/collection/browse_results.php?criteria=O%3ADE%3AI%3A1&page_number=66&temp_late_id=1&sort_order=1>. Accessed March, 2012.

¹⁸ Dietrich Neumann. “The Century’s Triumph in Lighting: *The Luxfer Prism Companies and Their Contribution to*

In 1907, Luxfer patented production processes for the first hollow-square glass block which was marketed as “Glass Concrete” and was intended to be used as an innovative alternative to other industrial building materials such as conventional red brick.¹⁹ “Luxfer's *Pocket Hand-Book*, which was an extensive catalogue sent to the Company’s prospective clients, marketed the Luxfer Prism as “...a "new building material" [which can] be made part of the surface decoration of a building and fight the current deterioration of architectural style”.²⁰ These Luxfer block units, sometimes referred to as “Glass Hole Stone” or “Glass Bricks” were less delicate and less decorative than Falconnier Briques. The Luxfer design became the foundation for the glass block designs popular in 20th century architecture.²¹

At the turn of the century, Luxfer had design and fabrication facilities based in Chicago, which at the time was on the forefront of progressive industrial architecture. The Luxfer Company hired Frank Lloyd Wright to develop prism designs for new glass tile products. The architect then went on to patent similar design concepts involving the use of glass among other industrial materials.²² “Luxfer's concept must have had a strong appeal for Wright, since it embodied his own sensitivity to the natural environment and his interest in new building materials and technologies.”²³

It has been noted that Wright’s forty-one completed designs for Luxfer were reminiscent of the work of the Architect’s former employer Louis Sullivan, who was famous for merging organic and geometric patterns in architecture.²⁴ Sullivan was a key figure in helping American architecture to move away from strictly utilitarian-looking buildings. Sullivan proved that even small architectural accents could humanize the appearance of a speculative office building. He was famous for adding Art Nouveau-inspired flourishes to the exteriors of his buildings and merging classicist tradition with modern refinement. The Architect employed the simultaneous use of expensive materials and inexpensive mass-produced industrial materials to make imposing

Early Modern Architecture” (March, 1995). *Journal of the Society of Architectural Historians*, Vol. 54 no. 1, Pp. 24-53. Electronic ed. by University of California Press on behalf of the Society of Architectural Historians. Site: <<http://www.jstor.org/stable/991024>>. Pp. 24.

¹⁹ “The History of Glass Blocks: *The Origins of Glass Blocks*”.

²⁰ Neumann, Pp. 28.

²¹ “The History of Glass Blocks: *The Origins of Glass Blocks*”.

²² Neumann, Pp. 26-27.

²³ Neumann, Pp. 27.

²⁴ Neumann, Pp. 27.

structures with a firm and established presence. Sullivan's decision to include these aesthetic additions to buildings made his work easily distinguishable from his American contemporaries who were mostly not known for expressing decorative styles in large-scale industrial architecture.

Historically, glass blocks have often been used in much the same way as Sullivan's industrial embellishments—they break-up concrete monotony. While Sullivan was not known for the use of the glass block medium, his use of glass in structures such as his *Gage Building* (1899) demonstrates an important change in the architectural history at the turn of the twentieth century. Glass was becoming more frequently used as a rhetorical divider to make the aesthetic of modern buildings more enticing. This is precisely why the glass block was able to gain a footing in architecture: there was nothing else completely like it at the time and it was not only a great spatial divider, but a multi-functional, long-lasting and inexpensive one.

These are critical areas concerning the project design, which needs to attempt to rejuvenate the initial appeal that glass blocks once had. In Sullivan's time, the glass block was 'not just a decorative window' and 'not just a brick'. It was a profoundly new object which offered the benefits of both a window *and* a brick, but had the added capability to be installed in a variety of locations of differing decorative styles. The project design needs to visually demonstrate that the device is 'not just a glass block' (now that the glass block is common knowledge) and 'not just a solar panel', but rather an innovative new device. The aesthetic must boldly state that the glass block is more useful than ever before and it still has the benefit of being a spatial divider and a creative, unconventional natural light source.

[The Luxfer Prism design] opens a new field to the artistic designer, and offers a wide range of possibilities to the architect who has heretofore been forced to cut his building to pieces in order to light it, and has been confined to the decoration of the meager wall surfaces around monotonous openings in the walls. When Luxfer Prisms are used as a filling for the window openings, their action and effect is totally different from that of

glass...they have an appearance of being opaque, with as rich and substantial a surface as any part of the wall of the building.²⁵

Considering the work of architects like Wright and Sullivan is pivotal to analyzing the potential design possibilities for the project design as well as in understanding how early adopters of glass blocks were able to persuade public opinion of them in non-industrial settings. Luxfer allowed both domestic architects and industrial architects alike to experiment with the new medium and while the Company had most of its assets focused on selling buildable glass products in mass quantity to factories, Luxfer also was able to pique the design interests of domestic architects. This is ultimately what broadened the appeal for the potential applications for the devices. The public had to see demonstrations of how glass blocks could be used in order to gain design inspiration for a wider, not so strictly-industrial sense of their versatility. Concerning the project design, it is important to realize that sometimes people have to be provided with inspirational design materials in order to create original designs of their own. The unconventional use of early glass blocks by prominent architects like Guimard and Wright provided this precedent for succeeding architects. It is almost comparable to product placement—like Marilyn Monroe endorsing Coca-Cola, for instance, but on a less-obvious scale.

At this point it is important to identify and differentiate between the two sides of the glass industry, “Art Glass” and industrial glass, which were becoming increasingly separate from one another around 1900. An object which falls into the art glass category places decoration and design aesthetic above functionality; an industrial glass artifact is the opposite, prioritizing function before form. If a glass object is more intended to serve as a reliable tool rather than as a decorative object, then that glass specimen falls into the industrial glass category. The great majority of Luxfer’s tiles and blocks fall into this industrial glass category. Despite the fact that some of Luxfer’s designs had non-functional aesthetic patterns, their shape and form was predominant over their appearance. Contrastingly, if a glass object was designed with the primary intention of being aesthetically pleasing (where any utilitarian purpose would be

²⁵ “Pocket Hand-Book of Electro-Glazed Luxfer Prisms Containing Useful Information and Tables Relating to Their Use” (1898). Luxfer Prism Companies. Henry Crew and Olin H. Basquin (Editors). Electronic copy courtesy of Ian Mackey of Glassian.org. Site: <<http://glassian.org/Prism/Luxfer/Handbook/page5.html>>. Accessed April, 2012. Pp. 5.

secondary, if existent at all) then that object would fall into the Art Glass category—something like a stained-glass window, compared to a plain clear-glass window for instance (which is strictly utilitarian), is considered Art Glass. A stained glass window is meant to look handsome rather than let the maximum possible amount of natural light through. Categorizing a glass object as being either an Art Glass object or an industrial glass object is all dependent upon its intended usage. The Art Nouveau Movement tried to blur or even erase this boundary through the creation of functional ornaments, which has been historically apparent in many types of glass products including some more ornate glass blocks.

Although most glass objects can be fairly easily categorized into one of these two groups based upon the object's nature and detail of ornamentation, it is important to take into account the fact that an object can fall into both categories, although it will almost fall exclusively into one more so than the other upon closer inspection. Cut-glass Waterford crystal serving bowls are one example of highly-decorative utilitarian glass. What makes some glass types difficult to define is how society reveres historical examples of certain types of glass. When the Sandwich Glass Company was operating in the 19th century in Eastern Massachusetts, many of their pressed and cut-glass products were inexpensive and utilitarian, often bearing flaws such as seam lines and air bubbles. This would imply that they were more for utilitarian, everyday-usage purposes. Today, Sandwich glass is highly collectable and original examples are viewed as Art Glass because they bore innovative and historically important designs. However, the bottom line is that many of these objects were intended to be utilitarian and were viewed as such when they were being produced.

This concept of dual-classification into the two contrasting categories applies to many examples across the glass industry, not just those specific to the Sandwich Glass Company. Considering this, it is therefore most accurate to classify glass products as either art glass or industrial glass based upon their intended usage at the time of their manufacture. The reason for this is that industrial glass can sometimes be considered art glass later in history, but art glass will always be considered art glass later in history.

The reason why the differentiation between Art Glass and industrial glass is pertinent to the project design is because the glass block industry, as it exists today, evolved because early glass tile and block designs were successful as industrial glass objects, not as art glass objects. The

vast majority of these early designs were developed mostly for industrial architecture applications and the manufacturers of these products proactively targeted buyers and markets who were mainly interested in the functional benefits of the blocks rather than the aesthetic benefits.²⁶ However, what made different block designs marketable was often aesthetic modification to the designs (the art glass component) which broadened their appeal in evolving design iterations that could better-match changing architectural styles and varying design tastes. It is difficult to say if Gustave Falconnier ultimately ceased brique production because of the inferior functional aspects of his design, but what is certain is that his strictly decorative units proved far less desirable in the marketplace than their industrial Luxfer successors. Hindsight is useful here in demonstrating that marketing a glass block has been historically successful mostly by putting functional design aspects before aesthetic considerations. However, it is equally true that attention to aesthetics can also play a major role in differentiating one design from another in the industry so these aspects clearly play a strong role as well.

Considering the “battle” between Art Glass and industrial glass in regard to the design development and architectural integration of early glass block products, it is important to take note of what the Louis Comfort Tiffany Company was doing with glass media around the turn of the twentieth century. In the early 1880's The Louis C. Tiffany Company had begun experimenting with pressed-pattern plate glass and open-mold glass casting to produce square glass tile. Production of these tiles continued on through the beginning of the twentieth century and ceased sometime around 1910. Although Tiffany made little impact on the glass block industry, the company did make an important contribution to the Art Glass tile industry, which contrasted the industrial tile industry that Luxfer had established itself in at the same time. In order to understand the full effect of industrial glass at the turn of the century, it is important to understand all aspects of the industrial glass industry. Like Luxfer, Tiffany made an enormous impact on the integration of industrial materials in the built environment but Tiffany did this through industrial beautification, Luxfer achieved this mostly through functional innovation.

Tiffany & Co. came into vogue in during the era of Art Nouveau and its product design aesthetics epitomized the natural-world themes which characterized the movement. Ultimately, this caused trouble for the Tiffany Company, which relied on the sales of intensely Art Nouveau-

²⁶ Neumann, Pp. 28.

styled objects for which the Company was best-known. Tiffany was still producing variations on their signature-styled Tiffany lamps and Favrite vases nearly two decades after the height of the movement and that proved nearly disastrous for the company.²⁷ It is possible that Tiffany's tiles fell into a similar situation after 1900, as the images of flowers and dragonflies which were embossed into them grew less desirable to the public as the progression into a more technical age caused trends in interior decoration to begin leaving these sorts of "old-world" romantic themes behind. These are important factors to consider in relation to the project design because they are demonstrative of how investment in trendy themes can be harmful to product designers if care isn't taken into developing current, or at least more art-movement-generic aesthetic designs. At the turn of the century, Tiffany was a stubborn, but innovative company which relied on its prestigious name to appeal to a wealthy demographic who wanted to boast affluence through material objects. Tiffany tiles were mainly used to decorate the insides of fireplaces and this was often done through contractual design through the Tiffany Company who dealt directly with the client. This was the case for prestigious projects such as the 1880-81 remodeling of the George Jones-William H. King "Kingscote" Mansion (Built 1839, Newport Rhode Island) where Tiffany worked with Stanford White of the McKim, Mead & White architectural firm to furnish several walls of the home with opalescent and stained glass decorative tiles.²⁸

The project design must try to avoid the utilitarian vs. art-object battle because the block design needs to be capable of mingling with different design tastes and social classes while presenting a maximum list for possible applications. It needs to demonstrate its versatility and adaptability and not be relegated to 'only patios'. Tiffany's tiles were often relegated to more industrial areas of the domestic setting such as the spaces around fireplace flues. This gave the tiles a reputation of 'still being tiles', despite their beauty. While Tiffany tiles may have been desirable to the wealthy elite, they were too expensive for typical homeowners who may have viewed the decorative potential for the tiles differently.

Appealing to different classes implies that the PV glass block needs to be symbolic of a lifestyle which is not specific to any one social class. This will broaden the creative applications for the blocks because different households will have different needs and ideas for using the devices.

²⁷ Schaeffer, Pp. 328.

²⁸ "Kingscote (George Jones-William H. King House), Newport Rhode Island" (August, 2010). From "Historic Structures". Site: <<http://www.historic-structures.com/ri/newport/kingscote.php>>. Accessed April, 2012.

The design concept is representative of a green, eco-friendly lifestyle and this is something which has achieved popularity across a wide spectrum of personality types and social classes. It is seeing how different types of people are able to use the devices that will inspire creative potential and establish iconicity for them.

While the project design is aesthetically representative of green living, the device should not be seen as an excuse for buying a greener lifestyle, but rather something which people can invest in, learn from and feel good about owning. Owners of the device should feel that the device makes their home more representative of the lifestyle that they lead; they should feel that it makes their house more descriptive of who they are as individuals. People decorate their homes to demonstrate their interests as well as their tastes so trendy things which have no deeper connection to their owners' specific passions are destined to become "decorations" rather than "accents". This was the case for the Tiffany Lamp, of which there are now only a limited number of examples because they started disappearing when Art Nouveau was out of vogue.

Accordingly, the project design must not be a decoration; it must be an icon which describes sets of ideals, priorities and tastes that others can relate to. The design can achieve this by being a functional architectural accent that improves a homeowner's opinion of the living space by describing that person's individual personality. That is what will make the PV block design timeless—if it is still representative of the owner's interest long after it is installed.

Concurrently, the design needs to attract persons that will buy it because it is something which they feel describes them and something which they see as being useful. It can't be something trendy that will experience a degrading opinion over time. While it seems fairly obvious that glass blocks are not currently a popular architectural or decorative fad, it is important to realize that the project design should not be marketed as something which is meant to be trendy. This is probably what killed Tiffany tiles and it could do the same to something like a new glass block design.

Infusing classic themes into the aesthetic design of a new product has historically been a successful move for many designers and marketers of mainstream consumer products.²⁹

However, deviation from conventional standards is often what defines a successful product and

²⁹ Vigne, 18.

this is especially true concerning aesthetics. Overtly radical design with too-few ties to tradition can be detrimental to the success of a product. This held true at the turn of the twentieth century, when there was a schism between the old world and a new age which was being driven by an increasingly machine-reliant lifestyle. The split between these two contrasting themes (essentially, transcendentalism vs. mechanization) caused a predicament for product designers:³⁰ should their products play-it safe with old-world aesthetics, or would investment in more contemporary designs prove to be a profitable risk and ultimately attract more customers? If the world can't digest the characteristics of a new design, the product will likely fail to win market acceptance.³¹

Tiffany products were successful at the turn of the twentieth century because they represented modern, industrial achievement, but they were not so different from past conventions that they were cast-off by the pop culture of their era.³² Tiffany eased its customers into modernism through gradual, incremental advancement. What killed Tiffany, however, was the refusal to step away from Art Nouveau after growing disinterest in the Movement's natural-world themes and styles became apparent around 1910 with the rise of Colonial Revival.

It is imperative that the project design is able to remain as functional and modern in style as possible throughout the duration of its lengthy lifetime. Because the glass block design is intended to have the capability of constituting a permanent wall or barrier within in a home, it is important that its owners feel that they can live with its presence decades after they purchase and install it. It should not be something like a glass Tiffany tile which gets cemented into a wall and screams "Passé Art Movement" two decades later and consequently proves to its owner that it was a regrettable investment, and worse, one which reminds the owner of that on a daily basis. Adhering to more modern, contemporary design aspects which have demonstrated their age in fewer ways than designs which involve movement-specific aesthetic details is probably the best way to ensure that the project design enjoys a longer lifespan of acceptance. The glass block design must attempt to remain representative of a man-and-machine bond that changed a culture

³⁰ Tim Putnam. "The Theory of Machine Design in the Second Industrial Age" (1988). From: *Journal of Design* (Oxford Journals: Oxford University Press on behalf of the Design History Society). Vol. 1, No. 1 (25-34). Site: <<http://www.jstor.org/stable/1315779>>. Accessed April, 2012. Pp, 25.

³¹ Scott Berkun. *The Myths of Innovation*. O'Reilly, 2007. Sebastopol, California. Pp. 48-49.

³² Schaefer, 313.

through progressive innovation. The design should aim to achieve in this order: (1) Impressiveness in the initial installation stage so the owner grows to like and appreciate it; (2) Sentimentality so that the owner enjoys the benefits of living with it over an extended period of time, and, (3) Nostalgia so that it is seen many years later as a design which is representative of much more than itself. This is what makes profound objects iconic of lifestyles and industries much more profound than the physical items themselves.

While there are a number of turn-of-the-century industrial artifacts that have managed to gain this type of timeless acceptance, it seems to be the ones which offer a level of mystery to the observer that have achieved great attention. The reason for this might be that older technologies often relied on the natural world in fundamental ways. Older technologies were more dependent on what nature could provide and the efficiency of these machines was only as productive and predictable as the natural medium which ran them, much like solar technology today. These types of machines are often mysterious to the observer because their function and application is not always apparent upon observation, yet their aesthetics describe a harmony between nature and technology on a fairly basic level. People are more comfortable around technologies which they can understand, so the project design should try to convey its functional principles through an accessible aesthetic. This will likely encourage greater interest in solar technology and potentially, a greater appreciation for the device.

Glass technological objects which adhere to this notion of intrigue via 'scientific mystery' seem to be especially strong examples of these types of aesthetically-pleasing mentally-stimulating industrial products. Glass is used less frequently in newer product designs than it was a century ago and this adds to the introspective side of observation. The present-day observer knows that glass has limited capabilities because of its fragility, so this makes it easier to guess the function of a glass object. This limits the possibilities of what an unusual glass object could be so it piques the human tendency for curiosity and makes the observe-and-guess process more enjoyable for the viewer. This is certainly something which the project design needs to take into account because the 'scientific apparatus guessing game' is likely to encourage greater interest in the PV glass block design. If this notion can be used to help develop an aesthetic which lures curious observers toward the device, then they will be more likely to take greater appreciation in the device after knowing more about how it works.

All of this relates back to the concept of nature vs. industry at the turn of the twentieth century. While Theodore Roosevelt was laying grounds for the American National Parks system, trains and other early motorized devices were providing greater opportunities for people to get closer to nature and to do it with the aid of industrially-crafted objects. The idea was that machines could not *be* nature, but they could be used as channels to make people closer *to* nature and to do it in the quickest, easiest and most enjoyable manner possible. While riding a horse down the Eastern Seaboard might have made a person physically closer to nature, the prospect of being able to take a vacation and see both coasts of the country in the same amount of time was much more appealing to Americans. In the battle of nature vs. industry, industry certainly won, but nature never lost its charm. This is one notion in particular that the project design must not lose sight of.

It is easier to see with hindsight exactly which aesthetic factors have made certain objects landmarks of the twentieth century, but it is more difficult to identify which factors will be symbolic of the present day in the decades to come. Product design has always been closely related to architecture because aesthetically-successful buildings achieve notoriety for the same reasons that iconic products do: people enjoy and appreciate them and over time, grow to respect them. However it is also true that some of the most profound examples of iconic products and structures came to popularity because they epitomized progressive ideals at a time when society was undergoing dramatic social change. There is a noticeable trend for highly controversial designs which are enjoyed by the few and dismissed by the masses, to gain extreme notoriety if and when the public majority later acknowledges the importance. Architecture defends this point particularly in the twentieth century because social, political and artistic movements changed so rapidly. This diversity was catalyzed especially by the rapidity of industrial fabrication advancements and the emergence of early Modernist design ideals which surfaced during the post-1900 years of the Second Industrial Revolution.

In order to grasp the full effect of progressive architecture in the early twentieth century, it is important to consider the work of more contemporary architects and designers who refuted delicate old-world and Art Nouveau designs in favor of more simple, bold and robust forms.³³

³³ Ross Anderson. "The Medevil Masons' Lodge as Paradigm in Peter Behrens's *Dombauhutte* in Munich, 1922"

These were the artisans who laid the foundation for contemporary design in the twentieth century and gave the world Modernism in the sense that the term is known today. These were the people that attached an aesthetic connotation to the mechanical expectancy in the word Modern. Many of the more profound figures who worked in this progressive style in the early 1900's were a part of the "Deutscher Werkbund", or "German Work Federation".

The Deutscher Werkbund was a revolutionary group of mostly Western European designers who took upon themselves the task of introducing Modernist design concepts which employed the fundamental use of industrial media. The Werkbund was dedicated to the idea of creating buildings, products and interior design concepts that functioned together as aesthetically 'cooperative' environments. Their idea was that one item should stylistically complement those around it without imposing too much attention on any single item. Concurrently, the group believed that no one item should be a distraction which forces the viewer to lose appreciation for the entire room or area, as the Werkbund held the perception of space in the highest regard. The underlying theory was to use the aesthetic contributions from rhetorically simple objects to collectively create an ideal environment. The goal was for this environment to be viewed as one cooperatively-functioning organism, rather than as a place to store and exhibit items which have varying degrees of appeal and thus distract from the appreciation of the overall space.³⁴

The Werkbund sought to prove that the space of a building was more important than the décor, which the group saw as an excuse to distract from the functional aspects of a design. The aphorism 'less is more' is very much descriptive of what the group tried to teach the world through its design elements.³⁵ In the eyes of the Werkbund, something like a chair, for instance, could not be appreciated if it was covered in furs, gemstones and carvings—it should be truthful and honest in its design so that it can be appreciated as a chair and not as an art object.

The Werkbund revered the design process itself as an art form, but saw the mass-produced objects which it yielded as objects of simple, good-taste which would contribute to a more dynamic building space. The Werkbund strove to prove that mass-produced objects should be

(September, 2008). From *The Art Bulletin*; Vol. 90, No. 3. Electronic ed. by The College Art Association. Site: <<http://www.jstor.org/stable/3047607?seq=2>>. Pp. 441.

³⁴ Frederic J. Schwartz. *The Werkbund: Design Theory & Mass Culture before the First World War*. 1996. New York: Yale University Press. Pp. 151.

³⁵ Mauro F. Guillén. "Scientific Management's Lost Aesthetic: Architecture, Organization and the Taylorized Beauty of the Mechanical" (2006). Princeton, New Jersey: Princeton University Press.

received at face-value and only appreciated for their contribution to the progressive design ideals of a developing modern society. While the Werkbund was focused on the idea of mass production and mass consumerism for industrially-crafted objects, it in some ways succeeded William Morris's nineteenth century ideal that industry *could* potentially be useful to society if sight of creative design ideals was not to be lost during the development process.

Peter Behrens, who was a prominent member of the Werkbund movement, achieved great attention for mass-consumer-oriented products which he designed for the German manufacturer A.E.G.. Most famous of all, however, was the architectural concept that the designer conceived for the A.E.G. Turbine Factory (1909), which employed the same minimalist design ideals that he employed in his product designs but applied on a large, industrial, architectural scale. Like all Werkbund advocates, Behrens held form in very high esteem, but not so much as to take away from the functional aspect(s) of whatever he was designing.

Art Nouveau mavericks designing during the early Werkbund years consistently valued form before function, even in the design of factories and public works projects where many critics argued that function should have been the primary concern.³⁶ The Werkbund philosophy on design, in most ways, embodied the polar opposite of this ideal by putting function before form. Art Nouveau designers believed that an object's beauty was a reflection of the quality and amount of effort put into decorating that item. The Werkbund believed that the beauty of an object was to be determined by how stripped it could be of decoration while still maintaining the core features that make it identifiable. The Werkbund viewed the beautification of an object as a design challenge more than as a form of individual expression: how simple and refined can this object be while still looking completely original and different from the other objects around it? If Hector Guimard and Peter Behrens were bringing wedding cakes to a bake sale, Guimard's would have been sprawling all over the serving tray and would bear a massive amount of icing decorations, numerous caverns and would be adorned with mysterious objects of various colors, shapes and patterns. Behrens's cake would probably look like a neatly-organized but strategically-arranged stack of slate slabs which would maximize space and light diffusion while

³⁶ Alastair Duncan. "Art Deco Lighting" (Spring 1986). From *The Journal of Decorative and Propaganda Arts*; Vol. 1, Iss. 1. Pub. Florida International University Board of Trustees on behalf of The Wolfsonian-FIU. Site: <<http://www.jstor.org/stable/1503901>>.

minimizing building materials. For Behrens, the decoration would be the entire object itself, not the decoration on it.

Comparing Art Nouveau design theories to those which were developed by the Werkbund is especially helpful in regard to the project design because it demonstrates the two possible extremes for designing with industrial materials. On one hand there is the attempt to coerce the public into purchasing something because it took a great deal of time to decorate, while on the other, there is the attempt to try and educate the public that the plain object which stands before them is symbolic of something much larger than itself, and that is why it is undecorated. The project design must try to incorporate aspects from both of these principles while maintaining its core functionality as a PV device. In order to better explore the possibilities for achieving this, it is important to consider Bruno Taut's Glass Pavillion.

German architect Bruno Taut constructed the "Glass House" (more commonly referred to as the "Glass Pavillion") for the 1914 Werkbund Exhibition in Cologne. Along with like-minded Werkbund Progressive Franz Hoffman, Taut set-out to in an attempt to prove that industrial materials could not only be used to craft beautiful things, but that new-age materials could be monumentally beautiful if used in monumental ways. The motivation for construction of the Glass Pavillion was twofold—firstly, to broadcast the potential for industrially-crafted objects and secondly, to showcase the modern materials donated by sponsoring manufacturers. Among several of these sponsors was "Luxfer Prismen Syndikat"—the German branch of the Luxfer Corporation who was looking to flaunt their new glass blocks, which comprised the walls substantial walls of the sizeable conical structure.

Aside from profound use of the glass block as a structural medium, there is one reason in particular that makes the Glass Pavillion a significant consideration in terms of the project design: it made use of industrial glass as a decorative medium. The Pavillion was meant to showcase the versatility of and variety of glass blocks available and to do this the building design utilized many different types of the units and employed them in various unconventional ways. Stackable, tessellating, mass-produced glass was a new territory in Western architecture and Taut's Pavillion introduced this medium in an eye-opening and inspirational way. Because the Structure was meant to advertise glass blocks to a wide audience, it broke the minimalist

conventions which Werkbund ideals adhered to in order to demonstrate the decorative potential for this progressive new industrial medium.³⁷

The building retained the fundamental Werkbund simplicity in its external appearance and floor plan but was unfaithful to the Movement's fundamentals in terms of its interior decoration. While there were very few decorative objects within the Pavillion, its interior was covered, walls, floors and ceilings, with vibrant tiles and glass block products.

The interior of the Glass Pavillion, especially the famous "cascade room", was an explosion of color and sensuous delight. It was filled not only with sober displays of information about the various sponsors' products (these were housed in a colorful "cupola room" above, under the dome) but with stained glass windows by Expressionist artists, illuminated from behind, walls of silvered glass, ceilings of brilliant glass panels, floors of colored glass mosaic, and a waterfall leading over a glowing base down to a "kaleidoscope room" at the base, illuminated with patterns of color changing every twenty seconds.³⁸

It has been theorized that Taut may not have intended for the Structure to be as intensively-focused on advertising ploys as it ultimately was, but that advertising may have been the ideal mode of communication approach for which to convey the power and potential for contemporary design and industrial media in that particular project.³⁹ This is a concept which could provide great wisdom to the project design, following the logic that a product which bears no signature logo must have identifiable characteristics if it is going to be memorable and symbolic of Modernity. Symbolism and memorability are two traits which the project design must emphasize if it is going to be iconic.

While the Glass Pavillion was not wholly reverent to the Werkbund Movement, it was an important demonstrator of what Werkbund ideals could bring to the general populous if society was willing to embrace greater use of industrial materials and processes. The Pavilion was

³⁷ Schwartz, Pp. 183.

³⁸ Schwartz, Pp. 183.

³⁹ Schwartz, Pp. 187.

iconic of fabricated beauty and although it was not the first aggressively-industrial structure built to flaunt this notion, it was indeed an early example of one which was mostly well-received by the public. The Building's individual components, colorful decorations included, functioned as one space-efficient organism according to the Werkbund belief in cooperative complementation of design components. The Glass Pavillion was an environment that people could relate to; it instilled optimism in its visitors who, potentially for the first time in history, could see that industry might be the investment that would finally lay the old-world reliance on nature to rest.

4.3 Post-War Modernism for Consumer Culture: 1919-1928

...America has struck out on new paths, is unhampered by European traditions of handicraft and applies the logic of industrial production to its forms.⁴⁰

The Art Nouveau movement had both arrived and ended with mixed opinion, but what it left the world with was an increased interest in industrial materials. In the World War I era, the idea of using industrial materials in design and architecture was showing signs becoming more of a practice than the experimental concept which it had been. The presence of industrially-crafted domestic objects was growing, and so was the demand for them. As there became a greater infrastructure for residential utilities including running water, electricity and natural gas, there became a subsequently greater demand for utilitarian devices such as faucetry, lighting apparatuses and stoves among other things. New technologies were revolutionizing the mechanical lifestyle which itself was representative of the increased liberties that could be gained from not having to depend so directly on nature. The focus of mass consumerism was changing to one which embodied efficiency and optimism rather than tradition and decoration. The Western world was prepping to embrace an age of potential and manmade accomplishment in the domestic setting.

⁴⁰ Schaefer, Pp. 313.

Despite increased potential for the industrial-domestic consumer market, designing and marketing industrial objects to Westerners in 1919 was still a difficult task. The public began to realize, however, that a step into modernity would require the acceptance of industrially-produced artifacts. What made this acceptance possible was a social change that made the switch from handcrafted to industrially-made artifacts seen as an ‘upgrade’ rather than simply a decorative statement. People could feel progressive *and* chic with their new appliances and furthermore, these objects could make homeowners feel that they were on the modern bandwagon, headed toward a brighter, more promising future. The project design will be a symbolic of this ‘optimistic material investment’ mentality because modern investment in green technologies is part of a growing social movement toward an environmentally-friendly society. This growing desire to invest domestic, eco-friendly machines is very similar to the initial adoption of domestic machines in the immediate years following World War I.

The general intellectual atmosphere of 1919 was totally changed relative to that of the prewar years. The war had plunged its survivors into material poverty and had left the people with a badly shaken currency, with privation, hunger and unemployment. The years of misguided patriotism bore fruits of political extremism...but also sobriety and a Candide-like confidence in the evolution of a better, more understanding world.⁴¹

The concept of keeping industrial materials involved in Post-WWI design and architecture relied on proactive measures because the pre-1920 public was not unanimously convinced that there could be inherent beauty in industrially manufactured artifacts. What changed this ultimately was the introduction of the automobile, and more importantly, Henry Ford’s *Model T*, which presented an affordable way for people to have their own personal locomotive facilitate interaction with society. It was a machine that was iconic of a freer lifestyle and one in which machines could offer opportunities for happiness. The *Model T* became a symbol of progression

⁴¹ Wingler, Hans M.. *The Bauhaus: Weimar, Dessau, Berlin, Chicago* (1962). Cologne: Verlag Gebr. Rasch & Co.. 1969 English ed. by The Massachusetts Institute of Technology, Cambridge. Pp. 3.

where happiness meets industry—something which the project design aesthetic needs to accomplish, precisely.

Had it not been for the dramatic technological advancements made during the nineteen-teens, the industrial aesthetic almost certainly would have undergone a much longer incubatory stage to gain acceptance than it did. Developing technologies and an increasingly competitive marketplace made industrial aesthetics a topic of growing importance and one which many manufacturers saw as worthy of investment. Because there was becoming such an abrupt influx of up-start industrial manufacturers—many of which were making identical or nearly-identical products—business in many consumer-product industrial industries was cut-throat and often purely price-based. Therefore, aesthetics proved to be an obvious and effective way to differentiate products and brands.

...American industry produced useful appliances that were not meant to “represent” anything but simply serve their designated purpose, and thus many of these anticipated the functional forms which designers in Europe began seeking only shortly before the First World War. The achievements of engineers in the field of technical, utilitarian architecture—for instance in the building of bridges, silos and warehouses—showed the way. The frank approach to technology swept away differences between “merely utilitarian” and “grand” architecture.⁴²

In 1919, a Modernist, progressive design school called the Bauhaus was founded in Weimar, Germany by the celebrated 20th century architect and designer, Walter Gropius. This was to be the first of three schools built in Germany (the other two in Dessau (1925) and Berlin (1932), respectively) which would devote great efforts to the intense study of minimalist expression and the embrace of industrial media. The Bauhaus was responsible for advancing and solidifying 20th century modern design principles which related industry to domestic products in a way that was expressive of individual style and taste. In both product design and in architecture, the

⁴² Wingler, Pp.1.

Bauhaus demonstrated to the public that aesthetically simple representations of industry are the visual representations that make industry beautiful. This is an important goal for the project design, which should aim to teach viewers about PV technology while encouraging passion for innovative, contemporary design and modern technology. If the project design seeks to achieve this, then it cannot be intimidating in its aesthetic appearance—it must be minimalist.

...the beauty of a work of art is a function of an invisible law inherent to the creative will, not of the natural beauty of a material; and that all material things are only subordinate mediating factors with whose help a higher state of the soul—the *Kunstwollen* [essentially, artistic volition]—is given material expression.⁴³

In previous decades, Gropius had been a vocal member of the Deutscher Werkbund and for the most part, his Bauhaus was the academic continuation of its core progressive ideals. What made the Bauhaus different, however, was mainly the fact that Gropius was an individualist⁴⁴ and believed that mass-produced industrial artifacts demanded variety, versatility and decorative adaptability if they were going to break the looming concept of mass-produced monotony. This is something in particular that weighs-in heavily in considering the design constraints for the project because the repetitive nature of stacked glass blocks can be discouraging to some tastes. Care must be taken in developing a design which allows the user to inject their own creativity into designing structures and barriers with the units so that the resulting product will be more representative of the owner's individual design preferences. Any undesirable, non-versatile industrial appearance has the potential to obscure the intent of the project design.

It would seem that as much as Gropius admired industry for its design potential, he lived with a fear that industrial ugliness would plague industrial artifacts unless progressive design progressed successfully. The Werkbund had focused primarily on bringing the efficiency of

⁴³ Schwartz, Pp. 21.

⁴⁴ Maciuika, John V.. "Wilhelmine Precedents for the Bauhaus: Hermann Muthesius, *The Prussian State and the German Werkbund*". From: *Bauhaus Culture: From Weimar to the Cold War*. 2006. Minneapolis: University of Minnesota Press. Pp. 20.

industry to the everyman with the idea that industrial beauty came from industrial achievement. Gropius believed that industrial beauty was a combined reflection of artistic effort, creative endeavor and unconventional innovation. While the Bauhaus mentality sought to expose the raw beauty of industrial materials, it attempted to do so through the use of creative design that would employ the materials in new ways and consequentially urge the public to see them differently while appreciating the notion of function before form. The Bauhaus became known for conceiving uniquely modern design aesthetics for mass-produced industrial objects. The industrial inspiration which the Bauhaus provided to the progressive mass culture has been critical in the evolutionary legacy of twentieth century design. This inspiration is what has allowed the glass block to continually find new applications across changing modes of domestic and industrial architecture in Post-World War I years.

Bauhaus design fundamentals were not the only thing revolutionizing modern design after World War I. The Roaring Twenties were the era of Art Deco—a massively influential and industrially-centered artistic movement which swept nearly all of America and Western Europe into the 1930's. Unlike most domestic consumer products made prior to the war, the industrial products of the post-World War I age could be made to look different in cheaper, faster and easier ways than before because of machining advancements. It was much easier to stamp a design into sheet metal than it was to gouge it out of wood by hand. Art Deco designers capitalized on this concept, incorporating industrially-crafted, machine-styled components into product designs and architecture.

The Art Deco movement relied heavily on geometry and unnatural forms. This allowed designers to explore creative paths with industrial materials and to experiment with the developing technologies which made these media available and workable. The more experimentation that occurred, the more product there was to show for it. As the appearance of industrial materials began to increase, both in decoration and in industry, the worry of disgusting the public with radical metallic designs began to lessen. Unlike the Bauhaus Movement, Art Deco employed the use of classical aesthetic themes. This too helped to ease the public into industrial acceptance through the introduction of linear abstraction (especially in geometric metalworking) with known and accepted artistic topics.

Even in the media—particularly in graphic designs on billboards and movie posters—metallic aesthetics began to establish a presence, proving that the era was representative of a cultural transition into a modern age. The people’s voice was becoming one of progressive mechanization. In many ways, Art Deco arrived in spite of the flamboyant artistic styles which preceded it, and with this, the public accepted the movement as a facilitator to escape the arduous and less productive hand-driven labor of the old world.

As the Western world advanced into the 1920’s, mechanically-dependent lifestyles were beginning to dominate over those which sought to reconnect with nature. At the same time, however, wheels and engines could provide ‘nature-on-demand’; those who embraced modernity could have the benefits of machines *and* nature. This is one notion which rings through to the present day and one which relates especially to the project design. The design must showcase an aesthetic that presents both its functional and aesthetic benefits in a way such that they simultaneously embrace nature and industry. The project design should be able to be appreciated from both a romantic, transcendental perspective and from a modern-industrial, contemporary design standpoint.

The transition to Art Deco made it clear that design experimentation involving industrial materials did not end with the death of Art Nouveau but rather, was really just beginning and on a much larger scale. Mainly, it was the Art Deco movement that encouraged a broad use of glass, concrete and metal in architecture, product innovation, interior and exterior design. More importantly, however, Art Deco associated not just the movement’s own image, but the *public image* with modernity, futurism and prosperity—achievements which it promised to deliver through the embrace of design simplicity.⁴⁵ The States were progressing beyond the heavily wood-based folk art that dominated the Country’s prior artistic movements and the Art Deco Era was making it exciting for its contributors and appreciators to abandon handcraft methods of fabrication. Like the Bauhaus Movement, Art Deco favored simplicity over complexity and in doing so, prioritized Modernist design ideals over those which had dominated design in prior movements. The United States had previously never been a lead contributor to artistic movements in Western Europe and while the United States was mostly a late-adopter of the Art Deco style, the US was a leader in the mass production of Deco consumer objects.

⁴⁵ Vigne, 17

The Art Deco Era was an all-encompassing age that affected every design challenge from women's jewelry to the creation of sky scrapers. America was advancing rapidly in terms of technological advancement and Art Deco was its freedom of expression. Although the same movement was simultaneously prominent across Western Europe, the US was unified under its optimistic outlook for machines which could offer better, easier lifestyles for its people. America was seeing prosperity proportional to the cities which were being rapidly erected and Art Deco embodied the concept of this financial and mental wealth.

[The Art Deco period was] quintessentially an era of popular modernism. Cosmetic Deco and moderne facades brought a face-lift to Main Street America by an applied architectonic skin of colorful, glazed terra-cotta, Vitrolite, ceramic or gloss metallic panels, glass brick, neon, and other Deco-era materials. At the same moment that European modernists such as Le Corbusier, Walter Gropius, and Ludwig Mies van der Rohe were defining an avant garde modern style based on lack of or minimal color, no ornament, and an emphasis of volume over mass, popular ornamentalists in America rejected the utilitarian for the visual, the intellectual for the sensual, the rational for the expressive, and the sociological for the purely decorative. Art Deco was jazzy, bright, sexy, loud, and visually appealing. If Bauhaus modernism and the International Style appeared to limit its focus to functionalism at the exclusion of emotionalism or expressionism, Art Deco found its appeal in the very color and excitement that polychromatic stylized facades, neon lighting, and zigzag profiles communicated.⁴⁶

4.4 Modernism and Mass Culture During the Depression: 1929-1945

Artistic advancements in the 1930's changed both consumer product designs and urban environments through bolder usage of industrial materials and linear forms. The technical materials and correspondingly modern design styles which employed them had quickly gained a

⁴⁶ Craig, Robert M.. "Art Deco". From: Encyclopedia of 20th Century Architecture. Sennott, R. Stephen (Editor). Vol. 1 (A-F). 2004. New York: Fitzroy Dearborn. Pp. 124.

following and a level of cross-cultural popularity that enabled the appeal of modern design to extend to different social classes.⁴⁷ Similarly, during the 1930's modern design had, for the first time in history, begun to greatly influence decorating styles within homes. One of the main reasons for this is that the middle class could afford designer objects which were made from industrial materials. Because of this, the use of industrial materials had become bolder in the 30's. The presence of machines and machine-crafted objects was becoming less disguised than it had been in previous decades—the line between the home and industry was becoming less distinguished. The integration between the western lifestyle and mechanization was becoming more fluidly integrated as modern artifacts became symbolic of progression and an independently-reliant but cooperatively constructive society.

One other reason that western society procured affection for Modern design—and a reason which relates to the project design especially—is that people had begun to realize that there were timeless elements to be appreciated in simple forms.⁴⁸ This was a notion which had previously been explored in the prior decades—notably by Adolf Loos whose 1908 essay “Ornament and Crime” highlighted the mental and financial waste resulting from investment in trendy, overtly-decorative items. Loos had been an early proponent of simple, refined forms and his opinions on spatial organization and simplification within the domestic setting inspired figures like Frank Lloyd Wright and Le Corbusier, whose impact on modern design in the 1930's (and onward) was monumental. Loos is noted for comparing modern architecture and design to the clothing industry, where women's clothing changes every season and menswear enjoys a ‘longue durée’, or, a longer time period for which it is considered to be aesthetically current.⁴⁹ His implication was that menswear is simpler in form and relies far less on evolving decoration than women's apparel, therefore it is more timeless.

Loos had been ahead of his time in this mentality, but by the 1930's, there was beginning to be an appreciation for his argument which was visible in the products coming out of the Bauhaus, Werkbund and even in the Art Deco Movement. Notably, the use of stucco in architecture became a staple in the 1930's as it forced the viewer to examine form through contrasts between

⁴⁹ Paul Overy. “Visions of the Future and the Immediate Past: The Werkbund Exhibition Paris, 1930” (2004). From *The Journal of Design History* (The Design History Society). Vol. 17, No. 4..

light and shadow. Industrial materials were pivotal in the 30's in experimental abstraction efforts. While stucco itself was not an industrial material, it saw a great revival in Deco style because it was being used in unconventional ways which gave the public new ideas for its potential applications. This concept is very much similar to what the glass block experienced during the Art Deco Era. Previously, the block had mostly been used modestly, with the exception of some extreme examples such as in the Glass Pavilion. During the Art Deco Movement, the glass block gained a stronger reputation as a Modern medium with unexplored potential, despite the fact that it had been in existence for decades prior to Art Deco. Designers were striving to create objects which would transcend future artistic movements. They were trying to make history by making things that were monumental because of profound innovation, not because of adherence to old-world tradition and historicism.

Despite the pitfalls which arose from the Depression, America in the 1930's was very much focused on investing in a new, industrial age which provided hope and promise for a brighter, more technical future. In some ways, this hope was representative of a more stable, reliable lifestyle that the middle class felt determined to invest in. For many, it was seen as a risky move to invest in business so people turned to material objects and instead invested in new-age products and home accessories—tangible things that provided immediate satisfaction.⁵⁰ Designers capitalized on this and produced products with technical appearances. These were products that made consumers feel like they were leaving the old world behind and were making a smart decision to embrace the new age of domestic industrialism.

In the 1930's, America was beginning to show signs hinting that an industrial presence was becoming something for homeowners to be proud of. Investment in modernity and time-saving domestic machines was a new concept. For many, it was an honor to be a proactive part of a society that shared the common ideal. While investment in a new industrial object gave homeowners something to show-off at dinner parties, it also gave the investor confidence in 'voting' for a more productive society. In the eyes of many, buying new technology was like paying for progress, rather than burning funds on a fad. Machines were in-style as long as they were functioning. Regarding the project design, green appliances can be viewed in a similar

⁵⁰ Lizabeth Cohen. "A Consumers' Republic: The Politics of Mass Consumption in Postwar America" (2004). *Journal of Consumer Research* (236-239). Vol. 31. Pp. 236. Electronic ed. courtesy of Harvard University Dash Repository. Site: <<http://nrs.harvard.edu/urn-3:HUL.InstRepos:4699747>>. Accessed April, 2012.

way, as they are representative of a specific type of culture, lifestyle and hope for societal progression. Green appliances are in-style as long as they are helping to make western living more environmentally friendly.

In many ways, the new industrial culture of the 1930's was reminiscent of the Marxist push for a Utopian society, where a decentralized government would put power into the hands of the people. If a job needed to be done, there were machines that could do it and take care of it quickly. The bankrupt economy emphasized the desire for and coveting of material objects that people could invest in and feel not only safe, but *proud* in owning. New products such as refrigeration units and automobiles made it easier for individuals to lead more independent lives. The machines, buildings and consumer products which sold best were those that had a refined, streamlined aesthetic reminiscent of the progressive new-age society. The 1930's defined itself as an age of abstract refinement.

For designers and architects, the 30's were fertile grounds for creative propagation. Although the decade was, in most places, and especially in America, a time of poverty, it was also a time of industrial prosperity. Wartime advancements in metallurgy and machining processes ultimately lent themselves to new innovations in both the product design and architectural worlds. From most standpoints, the 1930's represented an important time in history where the distinct entities of architecture and product design shared identifiable characteristics—a building might have had the same exterior style as a period vacuum cleaner and vice-versa.⁵¹ Modern objects looked like modern buildings and modern buildings looked like modern objects.

By the 1930's it had become acceptable, and in many cases *desirable*, to be in the presence of bare glass, concrete and metals. Where designers had previously gone to great lengths to paint or cover these materials, their natural, industrial aesthetic had become a fundamental design aspect of Modern design. The idea of showcasing the luster of polished steel on autos and building fronts and of sheet glass stacked row upon row of a skyscraper gave consumers pride in embracing the industrial age. This sudden demand for industry made artifacts and buildings from the period easily recognizable. The public wanted futuristic objects that were reminiscent of things like Ludwig Durr's *Hindenburg* zeppelin design, so domestic objects like polished

⁵¹ Vigne, 18

stainless steel wall clocks, candle sticks and barstools became desirable commodities. William Hawley Bowlus's 1930's automobile trailer concepts (which became the celebrated Airstream-branded line of campers and trailers) epitomize this consumer desire and the drive to design industrial aesthetics that would embrace the uniqueness of industrial materials and artifacts symbolic of progress and potential.

Increased interest in contemporary design and mechanized domestic devices during the 1930's was the inevitable result of the energetic progress of the Art Deco Era. While the 1920's may have been the beginning of mass consumerism, the 1930's became known as the age of mass consumption, where manufacturers and retailers dictated how and where to buy merchandise and in what quantities.⁵² People could buy bulk amounts of industrially-crafted objects which could complete tasks cheaply and efficiently. Machining became more productive and efficient and the cost of utilitarian devices had become proportionally cheaper.⁵³ Subsequently, the rise in consumer demand for industrially-made objects had continued to increase as a result.

Just as in the previous decade, there became an increase in the number of competitors in the industrial fabrication industry so the ongoing need for product differentiation was strong. Manufacturers continued to distinguish themselves from one another by focusing on design aspects. Rather than offering fancier decoration, higher-end products in the 1930's offered superior functionality or optional accessories meant to enhance the user experience and facilitate the modern lifestyle. While paying more for an object in the 30's probably would imply that its aesthetic would be different, a higher price tag would most likely mean that more time and attention was put into the design aesthetic, no necessarily how much more it was decorated or from what materials.

Even more so than in the previous decade, there became a critical need for companies to develop signature traits that would make *their* products distinct. The way that designers achieved this was by creating objects which were symbolic of modernity. In the 1920's, industrially-crafted products had been symbolic of modernity inherently because machines and manmade objects were so new that the presence of industrial objects had weight socially and culturally. By the

⁵² Jeffrey Kaplan. "The Gospel of Mass Consumption and the Better Future We Left Behind" (2008). *Orion Magazine*. Vol. May/June, 2008. Site: <<http://www.orionmagazine.org/index.php/articles/article/2962/>>. Accessed April, 2012.

⁵³ Kaplan. "The Gospel of Mass Consumption and the Better Future We Left Behind".

1930's, machines and machine-crafted object had not lost their novelty, but the public was growing more accustomed to the idea of industrialism in the domestic setting. The items which celebrated modernity through refined aesthetic were the objects which commanded consumer culture. The companies which made these types of objects included firms like Frigidaire, Maytag and Whirlpool—names that were synonymous with modernism and industrial innovation. These were the companies that demonstrated to consumers that there was great potential for mechanized autonomy. To an extent, these same companies still entice customers by the same conventions today: their brand reputations symbolize futurism.

In the latter 1930's and into the 40's, there became an even greater consumer demand emphasis for 'aerodynamic' aesthetics in domestic goods. As airplanes and automobiles rose in popularity and became staples of western culture, there was increased desire to take industry into the home—the feeling of living in and around modern accomplishment was comforting to western society.

Around this time, Art Deco was evolving into “Art Moderne”, or, more commonly, “Streamline Moderne”. This new mode of architecture and product design epitomized industrial simplification and it generally complemented Bauhaus and Werkbund beliefs in versatile, efficient buildings and artifacts capable of being rearranged without the need for redecoration.

Inspired by the aerodynamic forms and kinetic lines emerging from the drafting boards of industrial designers, a “Streamline Moderne” architectural style (dubbed “nautical moderne” when marine imagery was most explicit) evolved as one of the quintessential styles of the 1930s. In architecture, it borrowed from the streamlining evidenced in the forms of new transportation machines—planes, trains, ships, and automobiles—and streamlining was most frequently applied to buildings that served these transportation machines: air terminal buildings, bus terminals, marinas, and especially such roadside buildings as diners, gas stations, and car dealerships.⁵⁴

⁵⁴ Craig, Pp. 123-24.

It was during the era of Streamline Moderne that the glass block probably achieved its height in popularity, as it found many uses in both the domestic and industrial settings. The number of glass block manufacturers increased as the demand for the bricks did.

4.5 Mass-Production in Domestic & Industrial Architecture: 1945-Present

In the United States, the scarcity of labor combined with the low cost of materials provided a constant motivation for use of technology to develop building products that were more efficient to produce and install...Wartime demands led to the development of new technology and the refinement of existing technologies, leading to greater efficiency and a decrease in cost. The development of plastics, aluminum and pre-cast concrete systems were all advanced during the war years.⁵⁵

War efforts had prioritized the use and control of industrial materials and manufacturing facilities. There was a subsequent shortage of metal products available to western consumers at affordable prices and this was true for both the European and American consumer markets. What the war effort did not affect, however, were the machining advancements which continued to evolve during war-time efforts. By the 1950's, there were more people in the US buying homes, having children and leading independent lives than ever before and the subsequent need for affordable housing solutions was consequently high.⁵⁶

There are several key examples which make post-war affordable construction an apparent concern in the 1950's and one of these is Frank Lloyd Wright's concept of the "Usonian Automatic". Wright had been developing designs for inexpensive, easily erectable structures for

⁵⁵ Steven Avdakov and Deborah Griffin. "Common Materials". From: Representative Architectural Elements (245-293). Pub. on behalf of Heritage Architectural Associates. Electronic ed. courtesy of Ohio Historic Preservation Office (Ohio Historical Society), Columbus, Ohio and Ohio Humanities Council (National Endowment for the Humanities). Site: <http://www.ohiohistory.org/resource/histpres/toolbox/rp/rp_materials.pdf>. Accessed April, 2012. Pp. 245.

⁵⁶ Cohen, Pp. 245.

some time prior to the 50's, but it was not until after the mid-century that the Architect's concepts came to life and they did so in the form of stackable concrete blocks.

"The concrete block? The cheapest (and ugliest) thing in the building world. It lived mostly in the architectural gutter as an imitation of "rock face" stone. Why not see what could be done with that gutter-rat? Steel wedged to it cast inside the joints and the block itself brought into some broad, practical scheme of general treatment then why would it not be fit for a new phase of our modern architecture? It might be permanent, noble beautiful."⁵⁷

—*Frank Lloyd Wright*

Wright's tessellating block system consisted of interlocking bricks structurally capable of comprising the main portion of a medium-sized domestic building. The motivation behind this innovative style of construction was the Architect's belief that there could be a more efficient, affordable way to erect an aesthetically pleasing home than what the current solutions offered at the time. When placed together, the units made a mostly flat tiled surface in the form of walls and barriers which was functional and refined. The clay-like compound of which the bricks were crafted could be mixed on-site from raw materials and water, thus saving delivery costs for bringing materials to the building location.

Living within a house wherein everything is genuine and harmonious, a new sense of freedom gives one a new sense of life... The Usonian house, then, aims to be a natural performance, one that is integral to site; integral to environment; integral to the life of the inhabitants.⁵⁸

⁵⁷ Frank Lloyd Wright. From: [An Autobiography](#) (1977, Quartet Books, London). Quoted in David A. Hanks, "From the Middle West to Japan and California: 1911-1930" (111-134). Originally from: [The Decorative Designs of Frank Lloyd Wright](#) (1979). 1999 ed. by Dover Books, Don Mills, Toronto, Ontario. Electronic ed. courtesy of Courier Dover Publications and Google Books. Site:<http://books.google.com/books?id=7CXCKW3FOAgC&pg=PA139&lpg=PA139&dq=%22the+architectural+gutter+as+an+imitation+of%22&source=bl&ots=n5D_BKVVZe&sig=v5rc8MyFb5pZQB146ft0wdZmDo&hl=en&sa=X&ei=LOaXT42OEI-40QG-haSABw&ved=0CIMBEogBMAk>. Accessed March, 2012. Pp. 139.

⁵⁸ Frank Lloyd Wright. From: [The Natural House](#) (1954). New York: Horizon Press. Pp. 77.

The Usonian block system was Wright's contribution to solving the problem of practical home ownership in a changing, demanding world. This was a topic of extreme interest for many architects in Wright's era, notably those with ties to the Bauhaus Movement. Affordable housing presented the ultimate architectural challenge of sheltering a rapidly expanding population in a better-than-satisfactory manner—a problem which still has yet to be solved.

In many ways, form, function and purpose included, Wright's Usonian block system is very similar to the project design regarding the concepts of versatility and stability as they relate to the development of a functional architectural ornament. While the PV block concept is probably unlikely to be the main staple of the theoretical structures which it could be used in, the idea of creating an affordable, innovative solution to a common problem through the design of a stackable building component is the same. In both Wright's blocks and in the project design, the single buildable unit represents strength in numbers—it is nothing by itself, but is a solution when arranged in numbers. The single unit is iconic of the solution.

Wright was not the first to conceive the concept of a stackable building alternative, however. A company called Natco had developed a novel product called the "Natco Tex-Tile" in the early twentieth century which was essentially geared toward achieving the same end-goal of constructing an inexpensive and efficient fashion. In 1917 the National Fire Proofing Company had selected the hollow Tex-Tile blocks for use in an architectural competition to construct a single-story, one family home of less than 20,000 square feet.⁵⁹ It was stated that "...American Architecture has been characterized by an increasing tendency toward the use of permanent materials...[and that the]... competition had produced a number of designs of undoubted merit, showing the variety of effects that are possible with a thoroughly fireproof material, combining beauty and permanence".⁶⁰

While neither the Usonian block nor the Natco Tex-Tile was able to make a revolutionary impact on the design principles for constructing affordable homes, both designs were symbolic of an ideal much greater: inexpensive industrial materials can construct beautiful architecture. As the

⁵⁹ "The Natco Tex-Tile One-Family House: *A Selection of Designs Submitted in Competition by Architects*" (1917). Boston: Rogers and Mason Company. Pub. for The National Fireproofing Company, Pittsburg. Electronic ed. courtesy of the University of California and Google Digitization. Site: <<http://hdl.handle.net/2027/uc1.31822026927095>>. Accessed April, 2012. Pp. 5.

⁶⁰ "The Natco Tex-Tile One-Family House: *A Selection of Designs Submitted in Competition by Architects*". Pp. 5.

1950's progressed, there became an interest in 'Ornamental Concrete Block' which was a flat, mainly decorative accent that was staked on the exteriors of buildings, sometimes in front of windows, where it acted to some degree as a natural light diffuser.⁶¹ Ornamental concrete blocks were more of an architectural accessory than a buildable medium—they were not generally intended to be used as integral structural components. What is important to note about these however, is that the desire to purchase ornamental concrete blocks represented a desire to 'accessorize' architecture, and that is ultimately the direction in which the glass block would generally follow.

During the post-war 1950's, America focused intensely on the idea of homebuilding and this increased interest in domesticity emphasized the recently popular idea of buying mass produced objects to furnish a functional home. Prior to 1900, typical homeowners generally inherited, bartered-for or built the tools and furnishings which populated their homes. By the 1950's, Westerners were becoming focused on leading independent lifestyles, liberated from the ancestral bindings that bound-down previous generations of their heritage. This detachment from family meant that fewer items would be shared between individuals and this caused a great increase in the amount of consumer products which a person felt both compelled and entitled to own. Furthermore, the decade-long post-war baby boom (roughly 1947-57) encouraged the embracement of a facilitated, mechanically-dependant lifestyle. With more students attending college and an increase in the number of first-time homeowners, there became greater demand for modern industrial objects.

This concept of consumerism for the individual relates to the project design because it demonstrates the modern desire to own often unnecessary, but desirable home accessories. The idea of 'homebuilding' in America had become much less of a decorative *art* and more of a decorative *process*. In the 1950's American culture had begun to turn apparently materialistic and people had started to purchase machines for enjoyment rather than out of need—this was in part because of the economic rebound after World War II. Nevertheless, the project design, in the majority of cases in which it might be expected to be used, is not a vital machine, but one of desire. It is therefore important that the project design is not seen as a disposable accessory, but

⁶¹ Avdakov and Griffin, Pp. 248.

something which has the power to enhance a lifestyle in more ways than immediate, temporary gratification.

In most parts of the Nation, the glass block had already reached its climax in terms of popularity with the passing of the Art Deco and Moderne Movements. However, it is important to consider two facts in particular which contributed greatly to enabling the modest existence of the medium after the phasing-out of its nurturing parent-Movements.

Firstly, it is important to realize that the streamlined aesthetic, like most aesthetic styles, arrived much later in more rural areas, farther removed from the coasts. In suburban Ohio, for instance, the block was not uncommon in 1950's architecture and even in the city of Dayton it saw reasonable use during the decade.⁶² The glass block has seen large amounts of fluctuation in terms of use in America since the 1940's, but this idea of a 'delayed arrival' for the medium in some locations has probably been a key component in keeping glass block manufacturers in business during ebbs in its architectural desirability. This has almost certainly been the case concerning the time delay in the arrival of the Moderne styles in Eastern Coastal Asia and the Southern Pacific. The glass block came into vogue in China and Australia decades after its popularity peaked in America due to the rapid industrialization and architectural renovation which has occurred in the region since the 50's.

The second point to consider in regard to the continued production and application of the glass block is that the core fundamentals of the Modernist Style have not left Western architecture since their initial arrival. If anything, the principles of abstraction and refinement have only evolved since their initial conception prior to 1950. With the arrival of Postmodernism, the glass block again saw novel use in notable structures like Robinson's Equitable Tower (Saint Louis: Hellmuth, Obata & Kassabaum, 1971). Los Angeles Times Art Critic had this to say about esteemed Japanese architect Arata Isozaki's use of the glass block as it relates to Post-Modernist architecture:

Isozaki can be seen as a front runner in the new internationalization of architecture. The Miesian glass block previously represented the now-discredited "international style." It has given way to Post-Modernism. Geographically international, the new wave has also

⁶² Avdakov and Griffin, Pp. 275.

broadened its scope to sop up the historical influence of virtually all architecture from every time and place.⁶³

Throughout the 1960's, the glass block continued to find applications in various forms of architecture both in the United States and internationally while the Postmodern Movement began to gain a foothold in the architectural scene. What helped the medium greatly however, was the proactive work of figures like Jean Prouvé—a French architect and designer who dedicated great energy to investigating the aesthetic potential as well as the “economic and social applications” of industrial materials.⁶⁴ In the 1960's it was architects like Prouvé, Le Corbusier and Gropius that instilled Modernist design and habits of industrial exploration in the generation of their successors. Prouvé, has been noted for his application of “...the process of construction to the language of modern architecture...[and]...constant research into the nature of materials, production, form and design”; he epitomized the legacy of Modernism as it applies to industrial craft for the mass consumer.⁶⁵

'I noticed two things, one of these was the intense interest by technicians in the purely technical aspects of my projects, regardless of their content. The other was the equally intense interest shown by architects and users who saw in my projects an opportunity to modernise solely for appearances sake'.⁶⁶

—Jean Prouvé

Like many other notable architects of the twentieth century, Prouvé was also a designer. Prouvé stood apart, however because he was also an engineer and strove to view his design projects accordingly; he believed that good design requires a balance between rationality and

⁶³ William Wilson. “Art Review: Arata Isozaki: *A Tribute to the Master Builder*” (May 08, 1991). Electronic ed. courtesy of *Los Angeles Times*. Site: <http://articles.latimes.com/1991-05-08/entertainment/ca-1260_1_arata-isozaki>. Accessed April, 2012.

⁶⁴ Jean Prouvé: The Poetics of the Technical Object” (Media Release: 2007). Design Museum. Electronic ed. courtesy of Design Museum (Shad Thames, London). Site: <<http://designmuseum.org/media/item/72245/885/Design-Museum-Media-Release-Jean-Prouve.pdf>>.

⁶⁵ Richard Rogers, on Prouvé. From: Jean Prouvé: The Poetics of the Technical Object”.

⁶⁶ Jean Prouvé. Quoted in Remo Pedreschi: “The Innovative Lightweight Buildings and Systems of Jean Prouvé” (2008). *Advancements for Metal Buildings Congress*. University of Edinburgh, 2008. Site: <http://www.epaq.eu/db/docs/081023_07_Pedreschi.pdf>.

creativity.⁶⁷ While Prouvé was not known for working with glass blocks (his major focus was on metals), he conceived a number of structures which were designed for efficient, intuitive assembly.⁶⁸ Similar in some ways to Wright's Usonian blocks, and not far-removed from the idea of 1950's made-to-order 'kit' homes by Sears Roebuck & Co., Prouvé's ideas for component-based architecture are not so different from the basic assemblage principles of the project design concept. There is a clear relationship between the accepted, attractive, innovate products that Pouvéré designed and the balance of logic and creativity with which he used to design them. For Prouvé, this balance proved to be an effective way to understand the technicalities of his industrial mediums while not losing sight of the aesthetic design process which would make his products beautiful in the eyes of the public. This is an important lesson to keep in mind concerning the project design because an imbalance between technical rationale and design creativity could potentially make the final product either too ugly or not functional enough to be desirable.

During the 1960's the Brutalist style of building design had gained popularity in Western architecture and with it, the glass block maintained a presence in Modern architecture. Brutalism was characterized mainly by the prominent use of unornamented concrete—a medium (and aesthetic) which married easily with the glass block. One Brutalist structure which is particularly relevant to the project is Le Corbusier's Carpenter Center (1962) at Harvard University in Cambridge. True to the Architect's *five points* for creating profound Modern architecture, the building has remained a contemporary staple for decades.

In addition to showcasing a massive amount of glass blocks, the Carpenter Center exemplifies early efforts made toward developing environmentally-friendly solutions in industrial architecture. The natural light which the building is able to capture and the rooftop gardens which rest on top of it are multifunctional assets to the building. While these are reminders of the social and political changes which had begun to surface around the time that the Center was constructed, they are also symbolic of an ongoing struggle to find balance between nature and industry: they represent a timeless theme. The usefulness of natural

⁶⁷ Remo Pedreschi. "The Innovative Lightweight Buildings and Systems of Jean Prouvé" (2008). *Advancements for Metal Buildings Congress*. University of Edinburgh, 2008. Site: <http://www.epaq.eu/db/docs/081023_07_Pedreschi.pdf>. Pp. 5/58.

⁶⁸ Pedreschi, Pp. 20/58.

sunlight and the importance of environmental preservation will not only continue to be desirable points to address in architectural design, but they will be themes of growing importance. The building itself is more resistant to becoming dated because it continues to address current problems such as these through its aesthetic. Additionally, the building pads and revitalizes the reputation of the glass block medium by demonstrating its diverse benefits. The glass blocks on the Carpenter center are symbolic of cultural progress and of the importance of choosing non-disposable, eco-friendly mediums in industrial architecture. This is precisely what the project design needs to achieve through its aesthetic. Its image must supersede notions of a dated medium by demonstrating how useful it can be in terms of technological functionality, creative application and do so with a universally-decorative aesthetic.

In 1962, Rachel Carson published a book called Silent Spring (Boston: Houghton & Mifflin) which many consider to be a major instigator and the landmark beginning of the environmentalist movement in America. The Country began to become more wary of mass-produced industrial products, notably those made from 'non-descript' chemicals and manmade materials. People were becoming more concerned with what materials were considered to be safe in the domestic setting. Through the 1970's, these notions began to show varying effects on architectural design, particularly in architectural components and accessories of both decorative and functional natures. Because the glass block is made from a trusted and environmentally-inert natural substance, it was unaffected by the environmental scrutiny that examined domestic building materials from hardwood flooring to paint and insulation. The block continued to be employed in various architectural applications in various parts of the country.

In the 1970's there diversity in the off-chutes of modernism began to grow comparably similar to the way that the impressionist movement matriculated into others during the latter nineteenth century. Postmodernism continued to maintain an established presence in international architecture, but in most places, did not affect suburban domestic architecture as apparently as the Moderne Movements had. Postmodern architects like Robert Venturi and Deconstructivists such as Frank Gehry gained acclaim for advancing the evolution of the modern style through the use of industrial mediums and unconventional forms.

At this time in American architecture, the glass block went mostly into hibernation. This seems to be roughly the time when the medium began to see specifically noticeable applications, but more-so because it had lost popularity so its applications were more deliberate and obvious. It had become an unconventional medium rather than one which was ‘in the catalogue’ of common building supplies. In the international scope, however, the glass block was boasted in celebrated structures like Tadao Ando’s Glass Block House (Ishihara House: Osaka, 1977-78) and his Glass Block Wall House (Horiuchi House: Osaka, 1977-79). Ando worked in the Regionalist style of architecture, which brought some limited, but profound use of the glass block medium to parts of Asia and Western Europe.

In the latter 1970’s and early 1980’s, the Art Deco Revival Movement made a brief but punctual impact in architecture in concentrated regions in America, notably in Miami.⁶⁹ This period was a boon for the glass block and it provided a new generation of architects with the opportunity to gain an appreciation for the medium. Its use in Floridian architecture was meant to complement the dramatic sunsets and scenery of coastal architecture. It attempted to do so by offering a Modernist perspective that could provide the the chic comforts of contemporary upscale living while bringing inhabitants closer to the environment in a structurally honest and trustworthy way. This notion resounds in the design principles of Pierre Chareau as they applied to his primarily glass block Maison de la Verre (Paris, 1932).

Chareau embodied the avant-garde spirit by using industrial materials for residential construction such as...translucent glass blocks for the enclosure...[in an attempt to capture]...the dynamism of modern life by designing a kinetic architecture that could transform habitation of the space.⁷⁰

By the early 1990’s, the glass block had achieved favorability among a relatively small number of Western European architects such as Wiel Aret who made profound use of the medium in his Academy of Art and Architecture (Maastricht, 1993). It seems that the glass block was able to captivate the interest of architects who favored the Modernist Scandinavian

⁶⁹ R. Stephen Sennott (Editor). Encyclopedia of 20th-Century Architecture (2004). New York: Taylor & Francis Books, Inc. Vol. 1, A-F. Pp. 450

⁷⁰ Sennott, Pp. 121.

design principles of clean, healthy and simplistic living. The glass block agreed with the Bauhaus-inspired fundamentals that were dominating influential Scandinavian interior decoration and furniture design because it exhibited undertones of cleanliness and sterility, but did so through the natural medium of glass rather than chemicals and synthetics.

It was during this time that the glass block had essentially arrived at the plateau where it remains today. A number of European manufacturers were making glass blocks in the early 90's, many of which are still in business today and have made successful innovative attempts at encouraging the integration of the medium into (mostly) contemporary architecture. Seves S.p.A (Italian) is one notable manufacturer of craft and industrial glass blocks. Other makers like Vetro AB (Sweden) have created UV reactive luminescent blocks and have attracted the interest of niche designers while manufacturers such as Vitrablok s.r.o. (Czech) function mainly as manufacturers and distribute mostly through supply chains in mass quantity.

The technological advancements which have been made in the glass industry in recent decades have enabled greater innovation and adaptability of the glass block medium. In addition to increased aesthetic potential, modern glass blocks can provide superior “...stability and durability, as well as good insulation values, sound transmission, and fire resistance ratings”⁷¹ Additionally, the increased strength of some current glass blocks allows them to be used in load-bearing walls, which enables the construction of larger glass block structures such as Renzo Piano's 65,000 square foot Maison Hermès (Tokyo, 2001). This added strength also facilitates some design concepts for using glass blocks because they may not require the same support structures that some older, less-reliable blocks did.

Concerning the project design, it is helpful to realize that the Modernist style has historically had a platonic relationship with the glass block. It has been a bond which has proved both crucial to maintaining the presence of the medium and beneficial to furthering its development. In current architecture, it seems implied that the project design should exhibit modernist undertones because that is where the industry has proven currently successful.

⁷¹ “Designing With Glass Block: *Abundant Applications Provide Practical, Aesthetic and Green Solutions*” (October, 2007). *The Architectural Record* (October 2007) with Pittsburg Corning Corporation. Electronic ed. courtesy of Architectural Record Continuing Education Center and McGraw-Hill Companies Inc. (2012). Site: < <http://continuingeducation.construction.com/article.php?L=99&C=361&P=1>>. Accessed April, 2012.

Additionally, key timeless principles which have become associated with modernist style in the twentieth century appear to be what saved the medium because they allowed it to enjoy greater longevity of style and the ability to adapt between changing modes of architecture.

SunBlocks Design Model

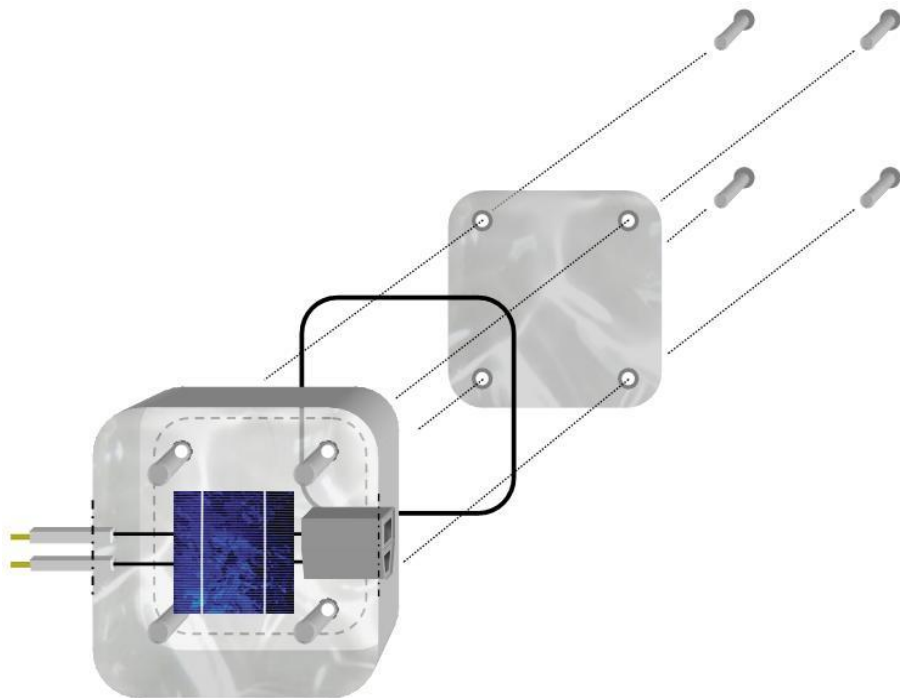

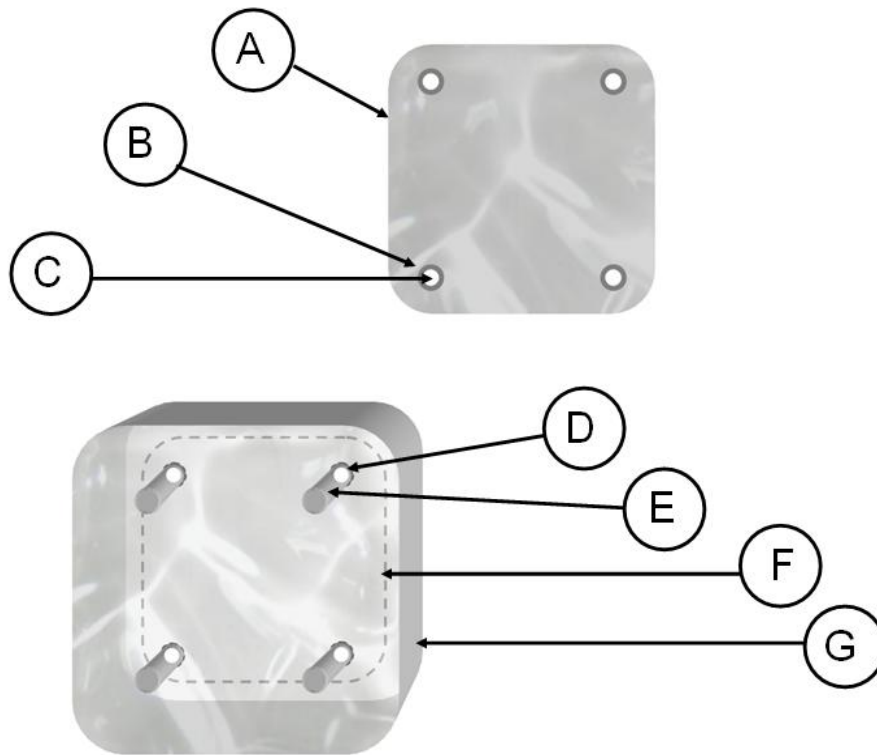

- A:** Outer back plate. Silica glass. Seals internal components inside of hollow, five-sided base-block unit which has open back.
- B:** Hole-rim gasket (x4). Neoprene. Helps to seal outer back plate onto base-block at four fastening points.
- C:** Bored hole (x4). Diamond-bit drilled through four fastening point locations on back plate. Allows fastening screws to tighten back plate to base-block.
- D:** Hole exposed in open back at end of hollow tube which is extruded from solid front façade of base-block (x4). Silica glass. Poured in graphite mould during silica casting process of base-block. Allows fastening screws to fasten back plate to base-block, sealing in internal components into base-block.
- E:** Hollow tube extruded from solid front façade of base-block (x4). Silica glass. Poured in graphite mould during silica casting process of base-block. Allows fastening screws to enter holes and fasten back plate to base-block.
- F:** Open back on five-sided base block.
- G:** Base-block. Silica Glass. Cast from graphite mould using molten silica glass. Side to have bored-through or cast-out opening to allow electrical terminals to extend beyond base-block edges.

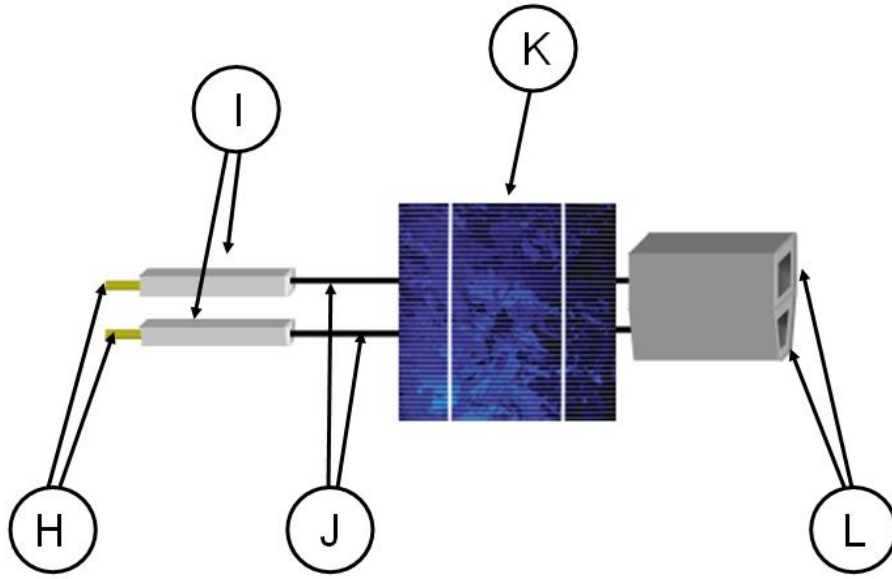

- H:** Male electronic terminal contact points (x2). Copper alloy. Tessellate inside of female counterparts, allowing power produced by PV cell to be carried through host block to other block units or termination destination(s).
- I:** Male insulating outer shells for contact points (x2). ABS plastic. Attach to base-block through holes in base-block sides. Serve to hold contact points in linear position, protruding from base-block. Prevent opposing contact points from touching/crossing polarities.
- J:** Electronic terminal wires. Copper alloy intertwined-strand core with plastic insulation shell. Carry power generated from host PV cell to sequential block or end destination(s). Parallel wired to PV cell allowing cumulative voltage between connected units.
- K:** Silicon photovoltaic solar cell. ~5.000V. Adhered to interior front façade of base-block. Generates power from collected sunlight which has radiated through front façade of base-block. Transmits generated power through attached terminal wires soldered to contact points on back of cell.
- L:** Female electronic Terminal contact points (x2). ABS plastic with copper alloy contact clips which accept male terminal contact points received from other block units or termination destination(s). Serve as the receiving, outer shell to host male outer shells for male contact points, which both tessellate internally inside of unit.

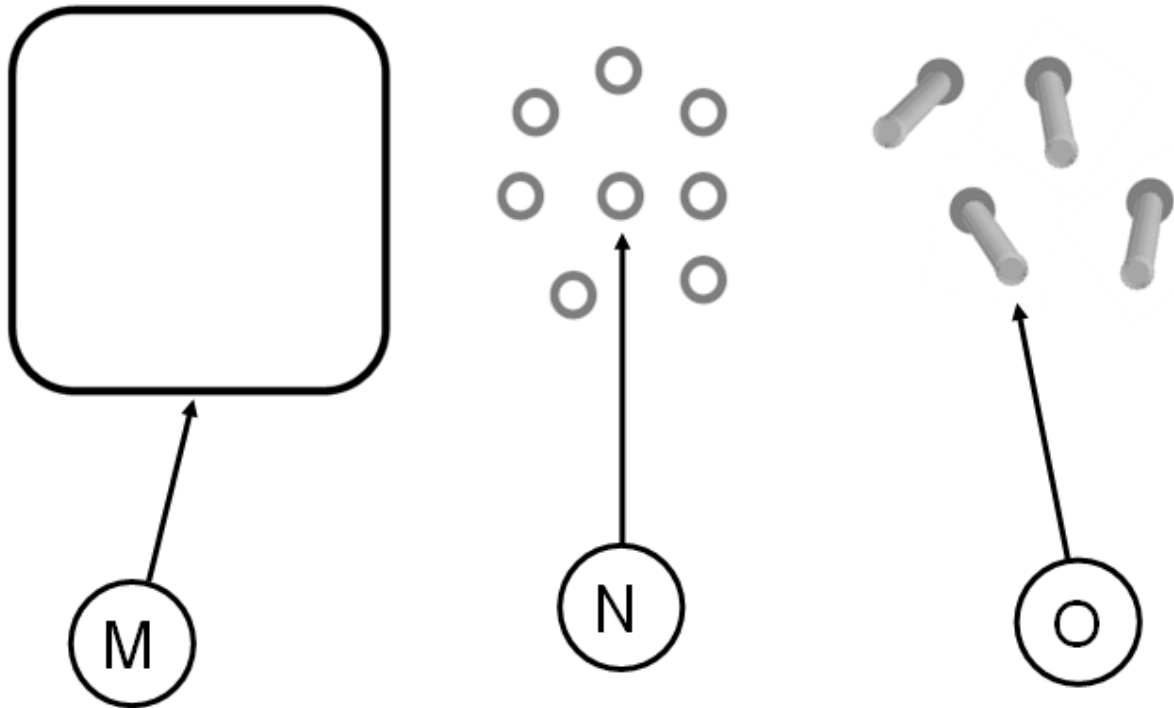

M: Sealant gasket. Neoprene. Helps to seal, fasten and secure outer back plate to five-sided, open-backed base-block. Lies along internal rim inside of base-block which is created during silica glass casting phase specifically to host sealant gasket.

N: Gasket washers (x8). Neoprene. Help to secure four fastening screws serving to secure outer back plate to open-backed five-sided base-block. Four gasket washers lie inside of four base-block at exposed-hole openings on back of hollow tubes (referenced as “hole-rim gaskets” in **B**). One gasket washer per hole-opening. Four gasket washers rest inside of bored holes (**C**) in outer back plate and serve to hold four fastening screws in place and prevent screws from exerting too much stress on outer back plate. One gasket washer per bored-hole.

O: Fastening screws. Neoprene. Secure outer back plate to hollow five-sided base-block unit which causes the entire unit and its respective internal components to function as one solid piece.



BLOCKS