

# **Walking Quadruped**

Nicole Franco, Nicoli Liedtke, Danny Lu

*Advisers*

Craig Putnam, William Michalson, Gregory Fischer

March 2019

**Worcester Polytechnic Institute**

*In partial fulfillment of the requirements for the degree*

*of*

*Bachelors of Science in Robotics Engineering*

# Contents

<b>Abstract</b>	<b>vi</b>
<b>1 Introduction</b>	<b>1</b>
<b>2 Background</b>	<b>3</b>
2.1 Robot Status . . . . .	3
2.2 Series Elastic Actuation (SEA) . . . . .	5
2.3 Robot Gait . . . . .	6
2.3.1 Crawl Gait . . . . .	6
2.3.2 Walking Gait . . . . .	7
2.4 Foot Design . . . . .	8
2.5 Stability . . . . .	9
2.6 Dynamics . . . . .	10
<b>3 Project Expectations and Time-line</b>	<b>11</b>
<b>4 Metrics of Success</b>	<b>14</b>

<b>5</b>	<b>Design Platform</b>	<b>15</b>
5.1	Code Structure . . . . .	15
5.1.1	Central Controller . . . . .	15
5.1.2	Leg Controller . . . . .	17
5.2	Gait Design . . . . .	18
5.2.1	Crawl . . . . .	18
5.2.2	Walking . . . . .	19
5.2.3	Turning . . . . .	20
5.3	Feed Forward Controller . . . . .	21
5.4	Electrical Design Overview . . . . .	22
5.5	Power Supply . . . . .	23
5.6	Mechanical Design Changes . . . . .	24
5.6.1	Foot Design . . . . .	24
5.6.2	Leg Design . . . . .	26
5.6.3	3rd Degree of Freedom . . . . .	28
5.7	Hardware Redesign . . . . .	34
5.7.1	Leg Motor Position Changes . . . . .	34
5.7.2	Series Elastic Actuation Removal/Improvements . . . . .	34
<b>6</b>	<b>Results</b>	<b>36</b>
6.1	Mechanical Analysis . . . . .	37
6.2	Crawl Gait . . . . .	38
6.3	Walk Gait . . . . .	40
6.4	Turn Gait . . . . .	41

<b>7</b>	<b>Recommendations Moving Forward</b>	<b>43</b>
7.1	Potential Improvements . . . . .	43
7.1.1	Mechanical Redesign . . . . .	43
7.1.2	Leg Redesign . . . . .	44
7.1.3	Sensors and Control . . . . .	44
7.2	Potential Future Projects . . . . .	45
7.2.1	Path Finding . . . . .	45
7.2.2	User Interface . . . . .	45
<b>8</b>	<b>Conclusion</b>	<b>47</b>
<b>9</b>	<b>Sources</b>	<b>49</b>

# List of Figures

2.1	Concepts of quadrupedal Crawl Gait . . . . .	6
2.2	Dog Leg Prosthetics . . . . .	9
5.1	System Structure . . . . .	16
5.2	Joint Angles . . . . .	17
5.3	Center of Gravity During Crawl . . . . .	18
5.4	Walk Gait Diagram . . . . .	19
5.5	Turn Gait Diagram . . . . .	20
5.6	Control Block Diagram . . . . .	21
5.7	Electronics Overview . . . . .	23
5.8	Old and New Batteries . . . . .	24
5.9	Examples of Foot Designs . . . . .	27
5.10	Foot Redesign . . . . .	28
5.11	Redesigned Legs . . . . .	28
5.12	Leg Finite Element Analysis (FEA) . . . . .	29
5.13	Third DoF Mounting Setup . . . . .	29
5.14	Torque Calculations . . . . .	30

*List of Figures*

5.15	Motor Requirements Calculations . . . . .	31
5.16	Kinematic Chain of Single Leg . . . . .	32
6.1	Walking Initial Position . . . . .	37
6.2	Quadruped Old Stance . . . . .	39
6.3	Quadruped New Stance . . . . .	40
6.4	Temporary Foot Fix . . . . .	42

# Abstract

The goal of this project is to create an independently moving quadruped. The platform for this project is a quadruped built by a previous WPI project. The platform is built as a base for attachments to enhance the use of the quadruped. The quadruped is a forty pound, four-legged robot. The project studies various walking and crawl gaits to translate the quadruped body at a stable speed. The team was able to attain unsupported walking through various hardware updates to its legs and electronics that resulted in weight reduction to improve walking. There were also significant improvements in the software structure and gait design of the quadruped.

# 1 Introduction

The following paper details the work done for a project in satisfaction with Worcester Polytechnic Institutes Major Qualifying Project for the Robotics Engineering Bachelors degree. The project was completed during the 2018-2019 school year.

The motivation for this project is to explore quadrupedal motion and the controls needed. This project builds off the quadruped built by the Quadrupedal Robotics Platform team in the 2017- 2018 academic year. During this time the team conducted extensive research to analyze what makes a successful walking quadruped. The research included the tools necessary as well as the physical motions.

Since the platform was built prior to the start of this project there are many constraints. This poses an interesting dynamic for the project as decisions made by the previous team strongly influence the decisions made for this project. Along the way the team needed to make decisions on whether to change or keep many



## *1 Introduction*

of the previously integrated design features. Each change was carefully analyzed and each solution considered.

The main task for this project will be to get the forty pound quadruped to function stably and reliably in the real world. By the completion of this project the robot will need to walk, crawl, and turn stably. This will serve to continue the original motivation of last year's team. Once the platform is fully capable of walking, crawling, and turning, future teams can make modifications to test new project ideas that require a stably walking base. While this team may not be able to produce a completed stable walking gait the team will analyze what is necessary and ensure that the robot is fully capable of doing so.

## **2 Background**

The completion of this project requires research on what the previous team has established as well as the tools available to accomplish the motion gait.

### **2.1 Robot Status**

The Quadruped Robotics Platform of the MQP from 2017-2018 created a primary platform with one-way communication so the user could control a fully built quadrupedal body. The platform was entirely designed, manufactured, and assembled with four 2-DOF (Degree Of Freedom) legs and weighed under 40 kilograms. Vex Pro 775 Motors actuated the leg joints with Vex Versaplanetary Gearboxes. The entire robot was powered by two 12V car batteries. These car batteries are not suitable as an onboard power solution.

The electrical hardware utilized by the previous MQP consisted of a series of embedded systems. A MicroZed 7010 was used as the main controller for the

## 2 Background

system. It was responsible for the highest level system control including gait control and inverse kinematics. This central controller commanded four Teensy 3.6 microcontrollers. The four Teensys are responsible for lower level control loops of their leg as well as the LCD screens for each leg. Each Teensy has two joints to control which is handled by two TalonSRX Speed Controllers. All communication between the MicroZed, Teensys and TalonSRXs is done via CAN Buses.

The previous MQP designed series elastic actuation into the quadruped legs. The series elastic actuators connect each axle to a potentiometer and motor using a series of gear chains. This gives the robot the ability to sense the torque on each joint by measuring the deflection of the potentiometer. However, this sensing was not implemented or tested on the fully assembled quadruped. The series elastic actuation assembly design required each joint to have a chain and sprocket gear train. This system also creates a large amount of slack in the motion of each joint.

The previous team also designed and manufactured foot sensors. The foot sensors were designed to fit in the casted foot for the quadruped. The sensor consisted of a 3x3 array of LPS25HB absolute pressure sensors. The sensors were tested independent of the quadruped, and a somewhat linear relationship was found between the load on the sensor and its readings. The sensors were never utilized or wired into the final built quadruped. Not enough data was collected to fully utilize the capabilities of the 3x3 array of the sensor and interpret each sensor's readings.

Through extensive testing and evaluation, the team decided to alter a few parts of last year's design before continuing with this year's core project goals. The first thing that needs redesign is the Series Elastic Actuation as it caused a lot of oscillations and slack in the legs. The batteries should also be replaced to possibly be on board the robot so it can walk independently. Lastly, the foot needs to be redesigned to ensure that each step can be stable and efficient. Research for the redesign of these parts is included in the next section.

Since the robot is now expected to run in real time it is important to account for synchronization, reaction, and cycle time. Finding the ideal timing for the robot's functions depends on the use cases.

## 2.2 Series Elastic Actuation (SEA)

Series elastic actuation is commonly used in robotic arm/leg applications to decouple the motor gearbox from the leg. It acts as a spring which reduces the impact on each leg making each leg more efficient when walking. The main advantage of using a SEA system on a robotic actuator is torque control (Hutter). When correctly implemented, it is capable of telling the robot when its leg is placed on the ground and how much pressure it is applying to the ground. The additional torque input sensing allows the robot to move through unknown terrain. This also provides cushioning through running gaits.

The addition of series elastic actuation adds another level of complexity in the robotic actuators through more chain links and sprockets between the drive motor and the leg; some of the drawbacks it has are that it makes the robotic actuation joints less stiff with a lower amount of accuracy. It also can cause unwanted oscillation when tuned with the wrong springs.

## 2.3 Robot Gait

### 2.3.1 Crawl Gait

Quadruped robots are often in the state of dynamically stable when moving, however in some cases (like the crawl gait) is constantly statically stable (Hwang, Youngil ). This creates a safer movement gait for the robots. In this gait, only one leg is lifted off the ground at a time. There are always three more points of contact on the ground.

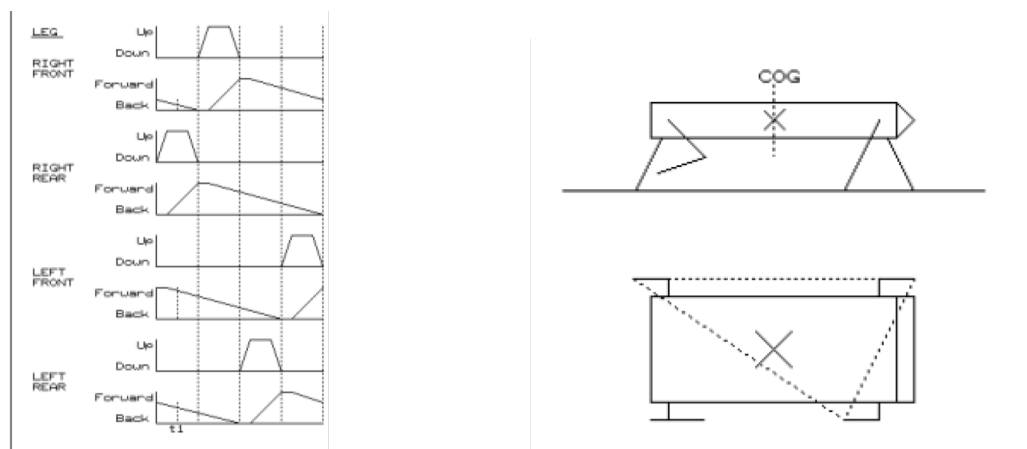

(a) Quadrupedal Crawl Gait (Liang) (b) Quadrupedal Center of Gravity (Liang)

Figure 2.1: Concepts of quadrupedal Crawl Gait

The crawl gait has movements split into four sections. In each of the sections, a different leg is lifted off the ground. Each leg picks up and moves forward during its section, and then moves backward during the other 3 sections. The overall action results in very smooth and even forward movement since all legs are in constant motion. The body remains level when translating through this gait.

The crawl gait has its stability from the tripod contact on the ground. It continually has the center of gravity of the robot within the bounds of this tripod. Many animals use its head or tail when moving to stabilize their center of gravity to be within this tripod area.

A few robots also tilt their chassis instead of keeping it level to change the position of their CG (Simplebotics). This could allow for longer strides per section in the walking cycle since the CG will be within the tripod area longer.

### **2.3.2 Walking Gait**

While the crawl gait may be more stable, a walking gait is faster and more closely mirrors the motion of a quadruped. Much like the crawl gait the movements of the walking gait are split into four motions, two motions are for stepping each set of the diagonal legs and the other two motions are for translating the robot after each step. However, a walking gait by definition needs to have two legs in the air simultaneously. The two legs then step forward. The step they take forward can be larger than the step a single leg takes in the crawl gait.

What makes this gait less stable than a walking gait is that when the two legs are raised the stable area is defined by a single line between the two feet that are making contact with the ground. To keep the robot in stable motion there are two main techniques. One is to shift the weight of the robot so that the center of gravity is in the area of stability even when the legs are raised. The other is to allow the robot to be off center and fall slightly but to catch itself when the two legs reach forward to make contact.

### 2.4 Foot Design

After running tests on the previous team's design, it became apparent that the feet needed redesigning to ensure a stable walking gait. Since the design of the foot is relatively flat and there is no ankle to compensate for the angle of contact the size of each step is very limited. The foot also needs to be compatible with a sensor that allows the robot to sense contacts with the floor. For stable motion, it is essential that the foot has sufficient contact with the floor at all possible angles of contact. Several designs could work in this situation. The foot could be designed to adapt to different terrains. The foot can also be flexible or round to make more contact. Like the dog prosthetic in the figure below(Prosthetics for Dogs and Other Pets.). There are a few sensors that could work in with these or similar designs. With springs; or some tolerance limit, switches can be placed to detect contact. Other sensors such as the silicon sensors last years team developed or gel site sensors can also be incorporated. Research, testing,

and development of the feet will be part of this project.



Figure 2.2: Dog Leg Prosthetics

## 2.5 Stability

To improve on the stability of the quadruped the team brainstormed on a few sensors. An IMU is a sensor that measures linear and angular motion, it is usually strapped down on the robot. It uses a set of three accelerometers and three gyroscopes (Xsens). This sensor can help level the quadruped through different gaits and also help keep the robot stable when in motion over unknown terrain or from external forces. Many of the motion gaits of the quadruped



requires it to be dynamically stable, meaning that the robot is only stable with constant adjustments from its motors. If the motors were to stop in the middle of a walk gait, the robot will fall over. The IMU will allow the robot to remain stable when transitioning the robot weight through its gaits.

A few different sensors can be used to determine the robots center of gravity(CG). In a quadruped walking gait, keeping the CG within the stable boundaries is crucial. Sensors such as foot sensors and Series Elastic Actuation sensors can be used to check and improve the stability of the robot.

## 2.6 Dynamics

Accounting for the dynamics of the physical robot is essential for success. Different phases of both the walking and crawl gait have different system requirements. "The main purpose of using feedback is to compensate for external disturbances and for model uncertainties" (Visioli,Zhong). For this project the external disturbances and discrepancies are caused by the reaction of the system at different points in the gaits. Slack in the joints and variation in impact angle causes excess torque to act on the motors. One method of feed forward control a simple model of prediction based on leg position. Another method is to use a proportional integral derivative controller, also known as PID. PID makes sure that the motor reacts appropriately to the system configuration to get it as close to the ideal configuration as possible.

### **3 Project Expectations and Time-line**

The goal of this year's work is to build upon the quadrupedal design built in the 2017-2018 MQP. As stated in the background the status of the robot upon starting the project called for an extended period repairing, tuning, and adjusting the physical chassis. The expectation for this project at completion is to have the quadruped walk stably, supporting its weight. This is broken up by goals for each term.

The first term of work is A term spanning from August 2018 to October 2018. The goal for this term is to evaluate the status of the robot and have it stand stably on its own. During this term preliminary movement tests were conducted on the robot. The team ran the inverse kinematics code for both joints on the leg. During these tests essential decisions about the direction and scope of the project were made. The types of design changes that had to be made were decided at this point. The communication between the various microprocessors was also explored at this point as well as potential issues. Through this process of exploring the robot, we came across many areas that needs to be improved to

### *3 Project Expectations and Time-line*

achieve stable walking. Many hardware materials need to be upgraded as well as the power transmission from the motors needed to be improved. There are a couple of complex features designed into the robot that needed simplification to reduce the amount of error to achieve walking. The combination of SEA, chain sprocket joints, and plastic 3D printed structure made the walking gaits for the robot almost impossible. These issues found in A term were then addressed in B term through different hardware and software updates.

The second term is B term where the expectation is to have the robot crawl and sense contact with the ground using the foot sensors. During this time, the team designed and manufactured a couple mechanical improvements to the quadruped and decided on more detailed directions for the robot. The constraints of the mechanical system guided changes to more detailed designs. The majority of B-term was also spent redesigning how on board controls communicate for speed and convenience. A couple of different communication methods were tested, including CAN control with only a single Teensy 3.6 micro controller, a single raspberry pi for gait and leg control, and distributed arduino CAN control.

The last term takes place in C term. Since this is the final term of the project the goal is to complete integration between walking and sensing. Sensing was made possible by simplifying the feet feedback with a single button as contact with the ground. At this stage a couple of crawl gaits and walk gaits have been tested on the ground untethered. The walk gait had to be run significantly faster than the crawl gait because it would lose balance quicker on two legs than three. Once integration is successful the team implemented the third degree of freedom

### 3 Project Expectations and Time-line

on each leg to allow for turning. The turning gait was able to rotate 90 degrees through 2 sets of steps.

Table 3.1 shows an overview of the project goals by term.

A-Term	B-Term	C-Term
Evaluate Robot Status	Re-design Foot	3rd DoF
Repair	Gait Tests	On-Board Batteries
Gait Design	Install Leg Sensors	Turning Gait
CG Calculations	Finish Crawl Gait	Walking Gait

Table 3.1: Term Goals

## 4 Metrics of Success

The success of this project is measured by the completion of features highlighted in the Project Expectations and Time-line. A successful walking gait requires the robot to have brief dynamic stability. Both the crawl gait and the walk gait should be tested and implemented to be stable control and locomotion of the quadruped. Both gaits should act as reasonable means for the quadruped to move forward. The final measure of success was through the implementation of the third degree of freedom. The implementation will be considered a success if the robot can turn at least 90 degrees in both directions without de-stabilizing. When measuring the success of the team, it is also important to account for our ability to react to decisions efficiently and effectively as well as our completion of each task in a timely manner.

# 5 Design Platform

## 5.1 Code Structure

The code structure for the quadruped is split into two sections, one is the central controller, and the other is the leg controller. The central controller uses C++ with the MicroZED FPGA. The four leg controllers use C++ as well with Teensy 3.6 microcontrollers to control motor controller and sensors.

### 5.1.1 Central Controller

The central controllers program contains all of the main movement controls for the four legs of the quadruped. It is the gait controller for each of the walking gaits. It aligns and controls the positions of each leg. All of the different movements that the robot can do are programmed into the MicroZED. The central controller also sends the initialization values to all of the leg controllers. All of

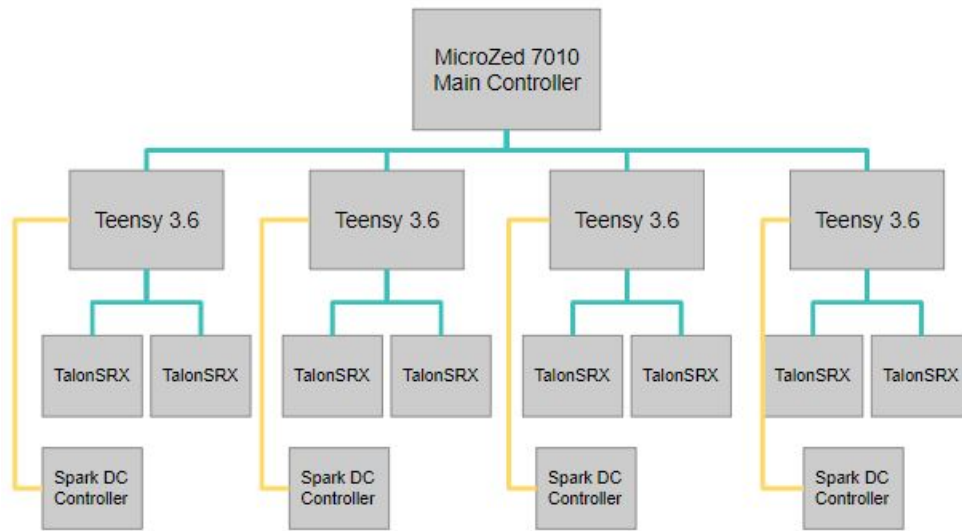

(a) System Structure

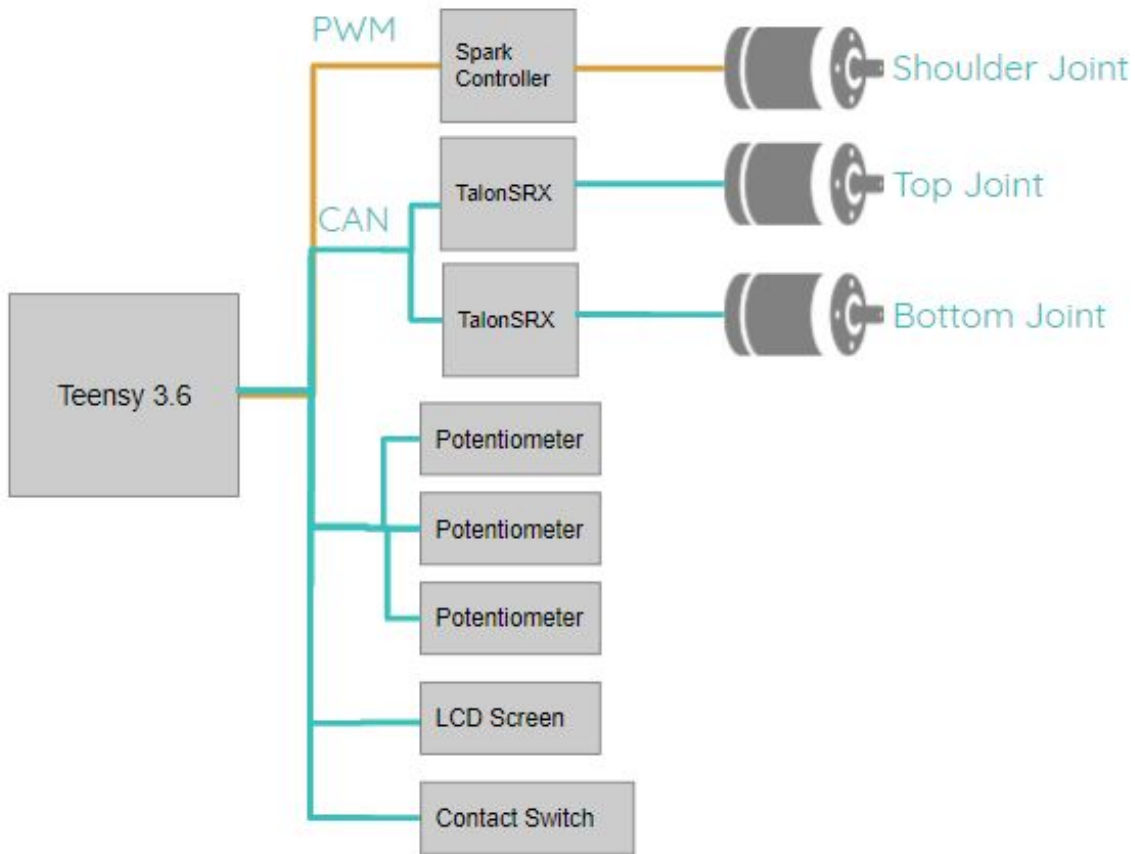

(b) Single Leg Structure

Figure 5.1: System Structure

the calibration values and PID tunings are sent to each leg controller for easier version updates to these values. To calibrate each leg, all three potentiometer readings are recorded at the 0 degree position and the 45 degree position.

Currently, the central controller controls both the crawl gait and walking gait through time intervals where positional values are sent at each set time interval to control the speed of the gait. It then uses the current position of each leg to determine the progress of each stage in the gait before it moves on to the next.

### 5.1.2 Leg Controller

Each leg needs to independently control each of the three joints. The range of motions for each joint is visible in the figure below. Joint  $\theta_0$  never moves away from the robot w

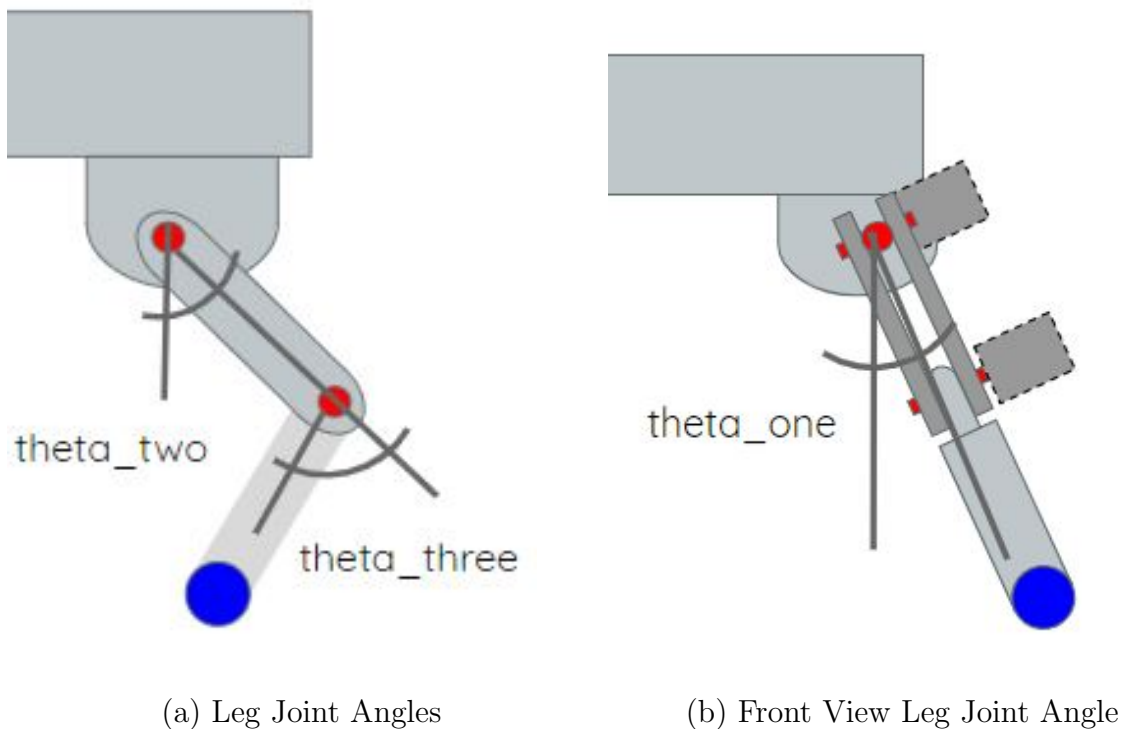

Figure 5.2: Joint Angles

The joint motion is then broken down into an array of smaller, achievable positions. Each position is then sent to the teensy where the PID controller sends voltage to each joint based on the potentiometer's position in relation to the goal



position. Each gait accounts for stability. This is done by calculating the center of gravity and shifting it at different points in the motion. The center of gravity shifts in relation to the feet positions by moving the chassis either forward or backwards. For our crawl gait the center of gravity shifts along one axis so that the side of the robot with one leg lifted bears less weight, keeping the center of gravity in the area of stability. In Figure 5.3 the crawl gait is depicted. The grey square indicate the main chassis of the quadruped that houses all the microprocessors and power supply. Each circle symbolizes a foot, when grey the foot is on the ground, when blue it is lifted.

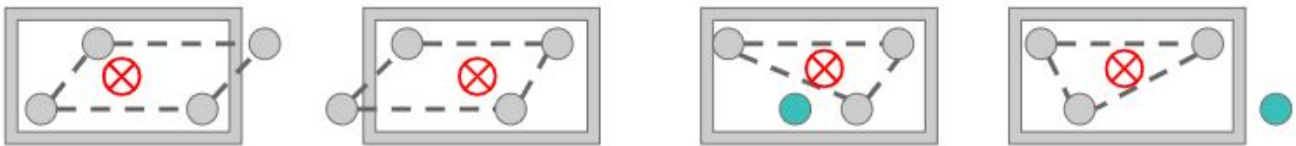

Figure 5.3: Center of Gravity During Crawl

## 5.2 Gait Design

### 5.2.1 Crawl

The first crawl gait that was accomplished on the quadruped was keeping all four legs on the ground at all times when the robot is not in motion. The robot shifts its legs forward when stationary and translates with four legs. After translating the center of gravity forwards and backwards a test was done to see if the robot could lift a leg up stably. After being able to stably lift a leg the gait shown in Figure 5.3 was implemented. The gait relies on a parallelogram, and both legs

on a side lift one after each other. By alternating sides and shifting center of gravity forwards between sides the gait can remain stable by keeping the center of gravity within the triangle support polygon of the three legs in contact with the floor. The gait should be able to take large steps while maintaining stability. A high speed of translation along with translating while stepping could allow the crawl gait to still move at a moderate pace despite only lifting one leg at a time.

### 5.2.2 Walking



Figure 5.4: Walk Gait Diagram

The walking gait has stages where the robot only has two legs on the ground. This means that the robot cannot be stable statically, it has to achieve dynamic stability or remain stable enough during quick steps. The balance of the quadruped could potentially be compensated with IMU (Inertial Measurement Unit) through its gyros and accelerometers. However, without the implementation of IMU's on the current quadruped, the approach for stability relies on lifting the two legs simultaneously as close to the balance line as possible and taking as quick of steps as possible. The walk gait was first implemented by standing in place and lifting two legs up and placing them back down. Testing showed that beyond 150 milliseconds of time lifting the legs could cause the quadruped to

tilt to far off center to an unrecoverable or unstable state. The walk gait could then be implemented with this time in mind as the maximum step duration. The basic stance for the walking gait is a trapezoid and once the legs that remain on the ground align with the center of gravity the other diagonal legs move together forward and form a new trapezoid. After translating the process can repeat with the other diagonals. The code for each complete motion is written as a state machine for each major stage of the walk.

### 5.2.3 Turning

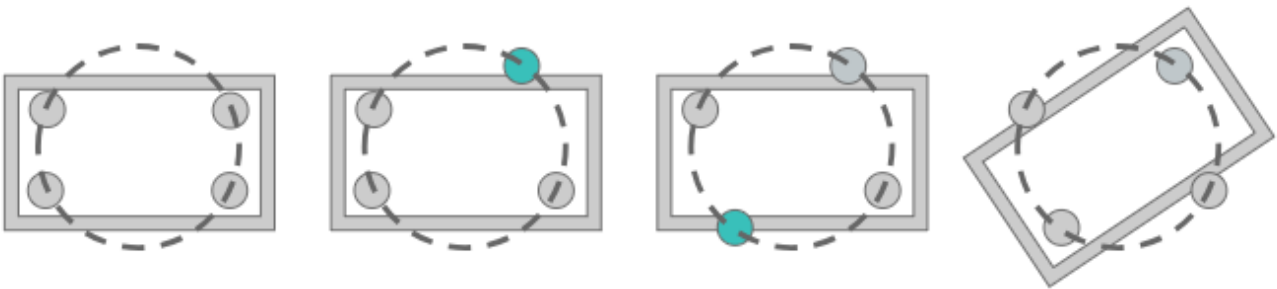

Figure 5.5: Turn Gait Diagram

A quadruped with planar two DOF legs is not meant to be able to complete a turn gait. A turn gait requires accessing a new axis and so a third DOF is necessary. There are many ways to kinematically turn a quadruped. The gait implementation developed relies on turning about a circle in the center of the entire quadruped as seen in Figure 5.5. The turn gait operates similar to the crawl gait by only lifting one leg at a time. Two diagonal legs are independently moved to equal angle offsets on the circle. Then all four legs can simultaneously complete a trajectory along the circle equal to the angle of turn. A function was developed to provide each legs position on the circle and account for the frame

transform from the center of the robot to each individual leg.

### 5.3 Feed Forward Controller

A feed forward controller was implemented to aid the control system from relying solely on a PID controller with imperfect gains. The feed forward controller aims to counteract expected forces on the joints from the weight put on each leg. New functionality on the Leg Controllers was added to provide an estimated weight on the leg controllers own leg. The leg controller takes this estimated weight and calculates torque, based on a static model, needed to maintain that weight given the current joint angles. The calculated torque is multiplied by a tuned gain to then add resulting voltage to the control of that joint. The central controller calculates the weight to send to each leg based on a model keeping track of the Center of Mass relative to each foot and which feet are contacting the ground.

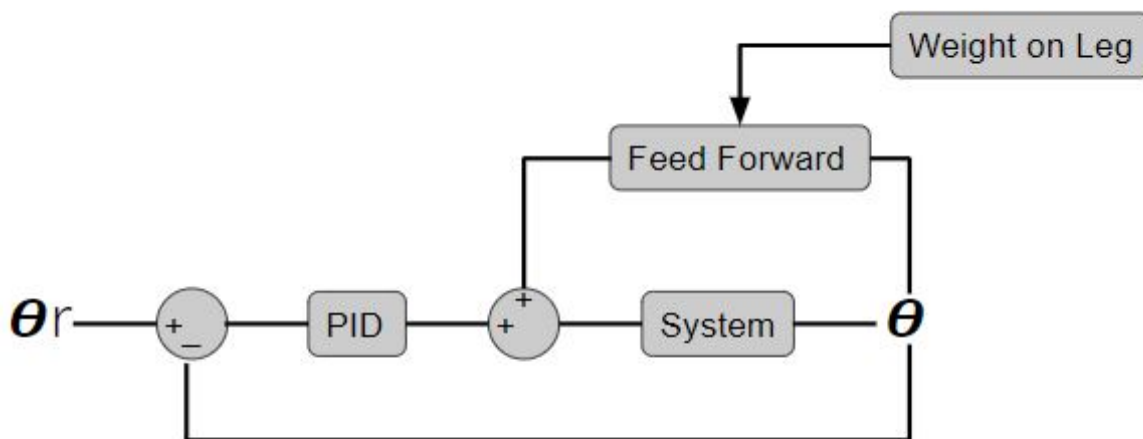

Figure 5.6: Control Block Diagram

Since the legs joint are expected to be in stall during loads that require feed

forward control there is linear relationship between output torque and voltage. This is used to create feed forward equation that increases voltage on the motor. A constant gain was used to tune the feed forward controller. The feed forward gain is denoted by  $K_f$ . The Teensy is given estimated weight from the central controller denoted by  $W$  in the equation.  $l_1$  and  $l_2$  are link lengths and  $q_1$  and  $q_2$  are joint angles. The feed forward controller calculates torque on each joint with  $W$ ,  $l$ , and  $q$ .  $K_f$  was then calculated and tuned based on motor specs to counteract the torque on each joint. The feed forward equations are expressed in equations 5.1 and 5.2.

$$F_1 = K_f * (W * (l_1 * \sin(q_1))) \quad (5.1)$$

$$F_2 = K_f * (W * (l_2 * \sin(q_1 + q_2))) \quad (5.2)$$

## 5.4 Electrical Design Overview

The main electrical interfaces between the microcontrollers is shown above. The MicroZed 7010 acts as a central controller for the whole robot. A single Teensy 3.6 controls all functionality for a single leg. Each TalonSRX is a motor controller for each joint of the legs. This allows for simpler code structure for each of the microcontrollers and more organized control for the four legs of the quadruped. All communication is done via CAN buses. Both the MicroZed 7010 and the Teensy 3.6s have two unique CAN bus lines. The MicroZed split communication for each side of the robot on their own CAN bus lines to two Teensys. Each Teensy

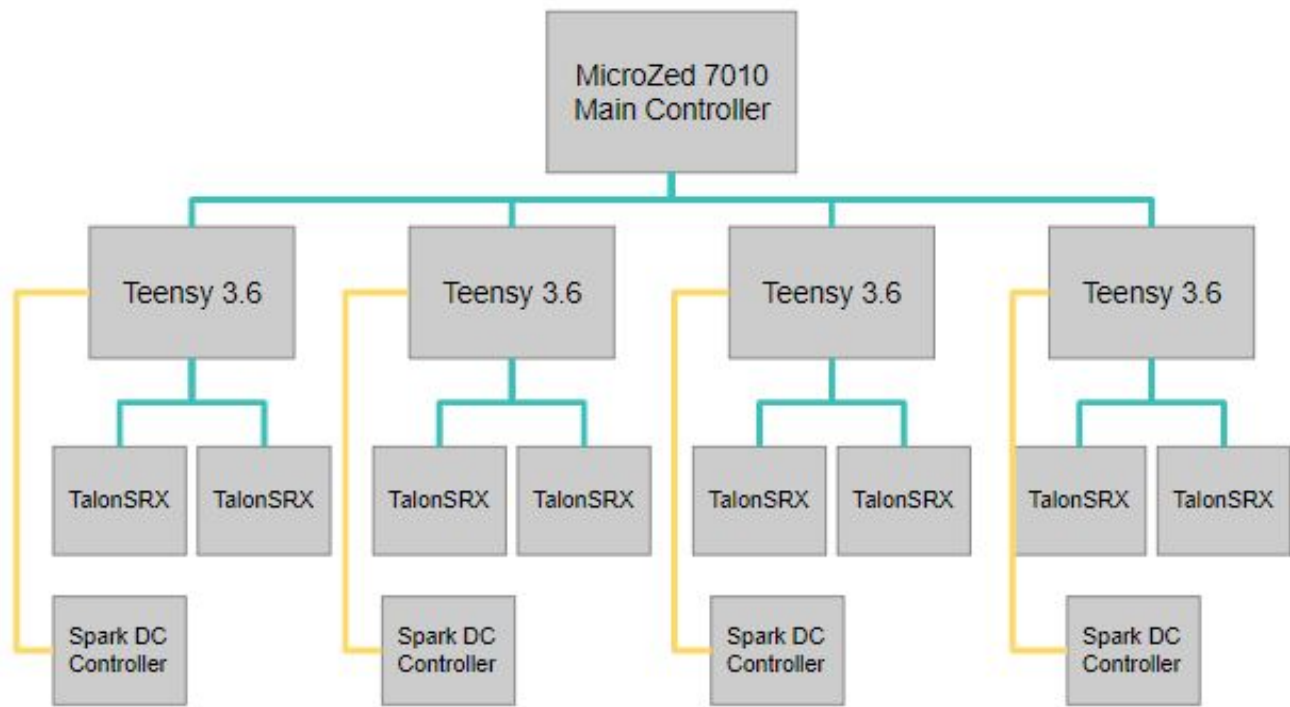

Figure 5.7: Electronics Overview

has one line to communicate with the Microzed and one line to communicate with the TalonSRX Motor Controllers.

## 5.5 Power Supply

The power supply used by the old MQP team were two lawn mower batteries weighing at 35 pounds combined. The weight of these batteries forced the team to run the quadruped tethered. These batteries had the capacity to constantly run the quadruped across 5-8 hours of constant testing. The power supply was then switched out to much higher power density lipo batteries. The quadruped was able to run off of two of these 8 Amp-hour batteries. These batteries weighed about two pounds each and was were able to be mounted on the robot. However,

the new LiPo battery packs had around a quarter the capacity of the lawn mower batteries so it is estimated around quarter of the run time from before. In Figure 5.8 the size comparison is clearly visible.



Figure 5.8: Old and New Batteries

## 5.6 Mechanical Design Changes

### 5.6.1 Foot Design

Redesign of the foot needed to allow good contact with the ground. Research showed 3 possible designs that we could implement. An ankle joint, an adaptive foot, or a rounded foot. It also needs to be able to include a method of detecting when the foot makes contact with the ground.

### Adaptive Foot:

This foot design is flexible enough to conform to the ground and has 3 toes that help with bumps. It can potentially be entirely 3D printed. In this case a switch would be attached to the bottom of the foot.

### Rounded Foot:

A rounded foot design means that whatever angle the foot makes contact with the ground has the same amount of surface contact. This would be difficult to manufacture; it can be constructed from a wheel or printed out of Thermoplastic Polyolefin (TPO). A flex sensor can be attached to the bottom.

### Ankle Joint:

This design has a spring loaded ankle that conforms to the ground much like the adaptive foot design. However, in this case the materials do not need to be flexible, the compliance takes place in the springs. The foot can be 3D printed or machined. The switch would go on the bottom of the foot.

In order to evaluate all three options a design matrix was created. Each design is rated in the six categories on a scale from one to three, with one being the worst and three the best. The design matrix can be found in table 5.1. From the design matrix the ankle joint was chosen. The feet were machined and the bottoms were 3D printed out of TPO to give it some traction.



	Durability	Cost	Manufacture	Adapt	Compatable	Utility	Total
Adaptive Foot	1	2	1	1	2	1	8
Rounded Foot	2	2	3	2	1	2	12
Ankle Joint	3	2	2	3	3	3	16

Table 5.1: Foot Design Matrix

## 5.6.2 Leg Design

The leg was also redesigned to be slimmer and stronger. Since the series elastic actuation was found to introduce so much slack it was entirely removed. The motors were rearranged to directly drive each joint. The SEA hardware was also removed due to electronics and hardware restrictions. The pots chosen for the quadruped did not have enough accuracy to properly incorporate the SEA system. The setup from the last MQP would also need different springs for the compliance as the deflection from external torques were not high enough to be measured. Without the SEA the bottom half of the leg could be slimmed when it was machined along with the leg to allow for a spring loaded ankle joint. The new bottom halves to the legs are approximately 30% of the weight of the previous bottom halves. The primary purpose of the redesign of the bottom half of the legs was just to accommodate the newly designed feet. However, the new bottom link is substantially lighter than the previous version.

The legs have all been simulated to maximize their strength to weight ratio and all have a factor of safety of three for normal operation of the quadruped in each axis with the force of the chassis.



(a) Adaptive Foot (Eckert, Peter)



(b) Rounded Foot (S. Ivaldi et al)

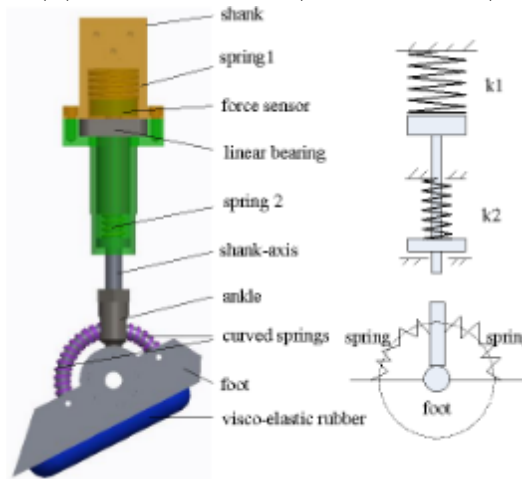

(c) Ankle Joint (Lv, M.)

Figure 5.9: Examples of Foot Designs

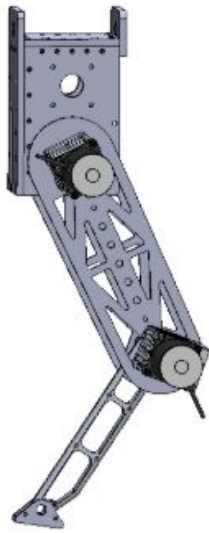

(a) Foot Redesign CAD



(b) Foot Redesign on Robot

Figure 5.10: Foot Redesign



Figure 5.11: Redesigned Legs

### 5.6.3 3rd Degree of Freedom

The 3rd degree of freedom is vital to the quadrupeds ability to turn. This 3rd degree of freedom needs to be installed on all four legs. The motors will be placed

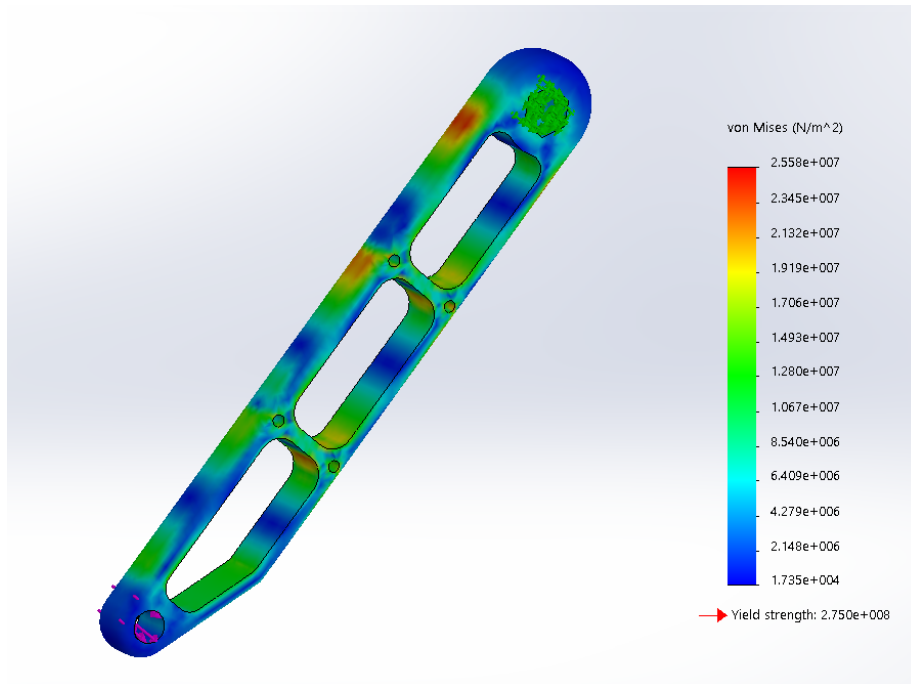

Figure 5.12: Leg Finite Element Analysis (FEA)

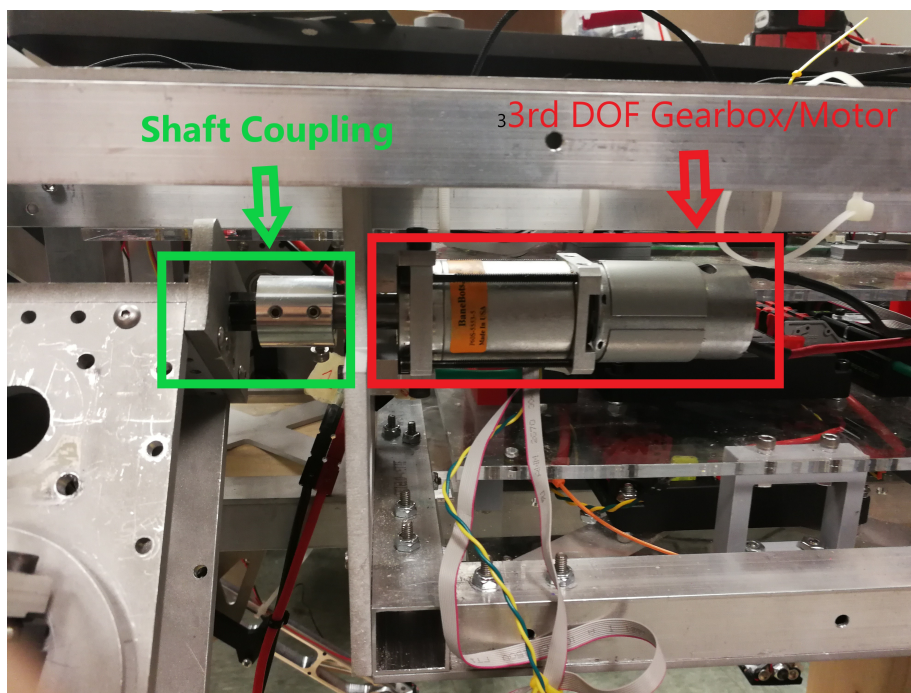
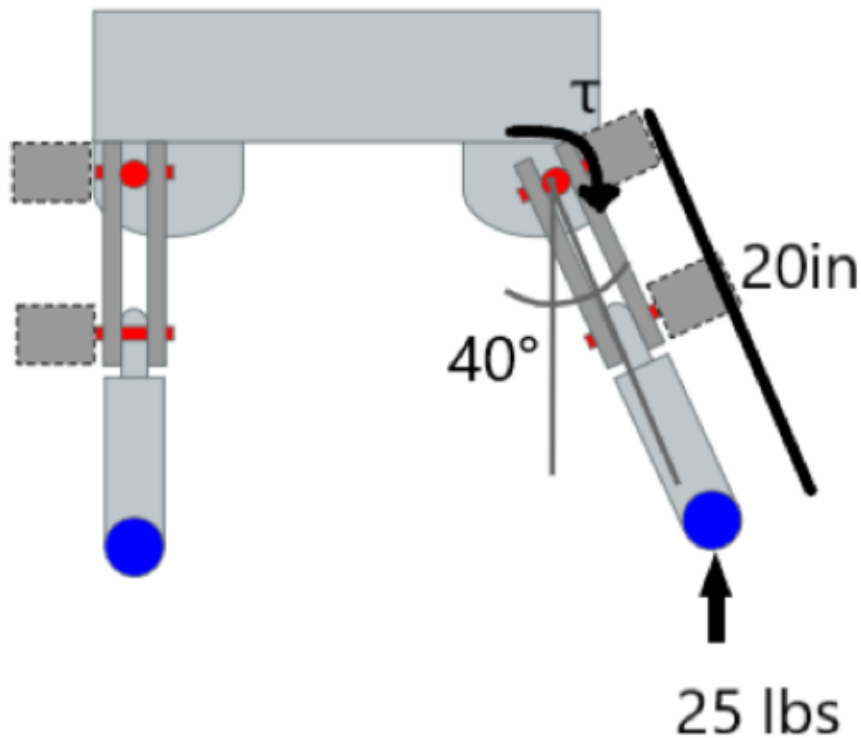

Figure 5.13: Third DoF Mounting Setup

at the shoulder joint shown in the figure. The image is a close up of the motor attached to the top of the leg. The motor, which can be seen with an orange tag, is attached directly leg via an axle. These motors need to have to be strong enough to move the legs 40 degrees.



Perpendicular distance from force:  
 $\sin(40^\circ) \cdot 20in = 12.86in$

Torque calculation from distance:  
 $25lbs \cdot 12.86in = 321.4 in \cdot lbs$

Figure 5.14: Torque Calculations

In order to calculate the torque, the diagram below was analyzed. Assuming that the maximum desired angle would be 40 degrees we calculated the torque needed at this extreme. Since the quadrupeds legs will always have a slight bend for stability the length from the motor to the ground is 20 inches. The maximum weight it would hold is half the robots weight, 25 lbs. With this in mind, the torque required is 321 lb-in using  $\tau = W * L$ . Where W is the weight on the joint and L is the length to the ground. Speed is also a factor in choosing a motor so that we are not restricted when moving.

The motor was picked to have at least 800 in\*lbs of torque. It was mounted directly on the shoulder making so the the joint is direct driven. The gearbox chosen has a 444:1 gearing ratio. The stall torque is 1940in\*lbs,which is above our requirements. With no load of max RPM is 43, which is above our desired RPM of 40. However with max load the RPM is 34. While this is below our desired RPM the team decided to still go with these specification as it provided sufficient torque with only a small sacrifice in speed.

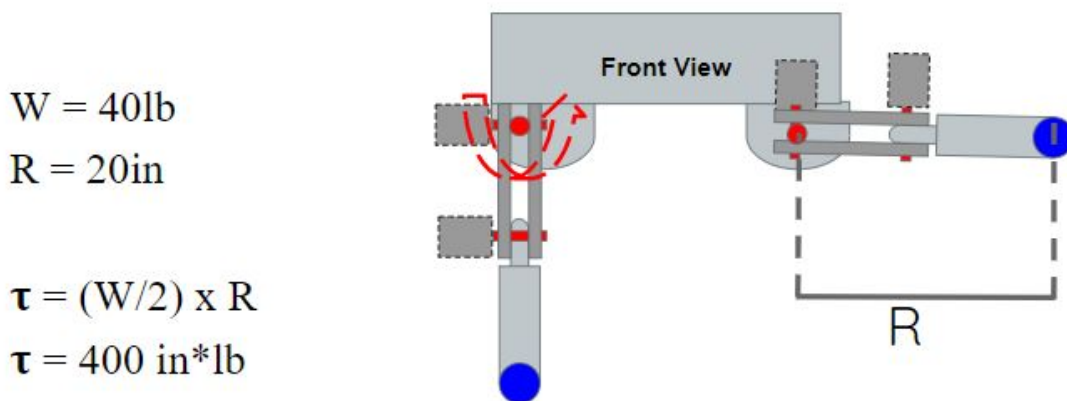

Desired  $\tau = 800 \text{ in*lb}$

Desired  $\omega = 120^\circ \text{ in } 0.5\text{sec}$   
 $= 40 \text{ rpm}$

Figure 5.15: Motor Requirements Calculations

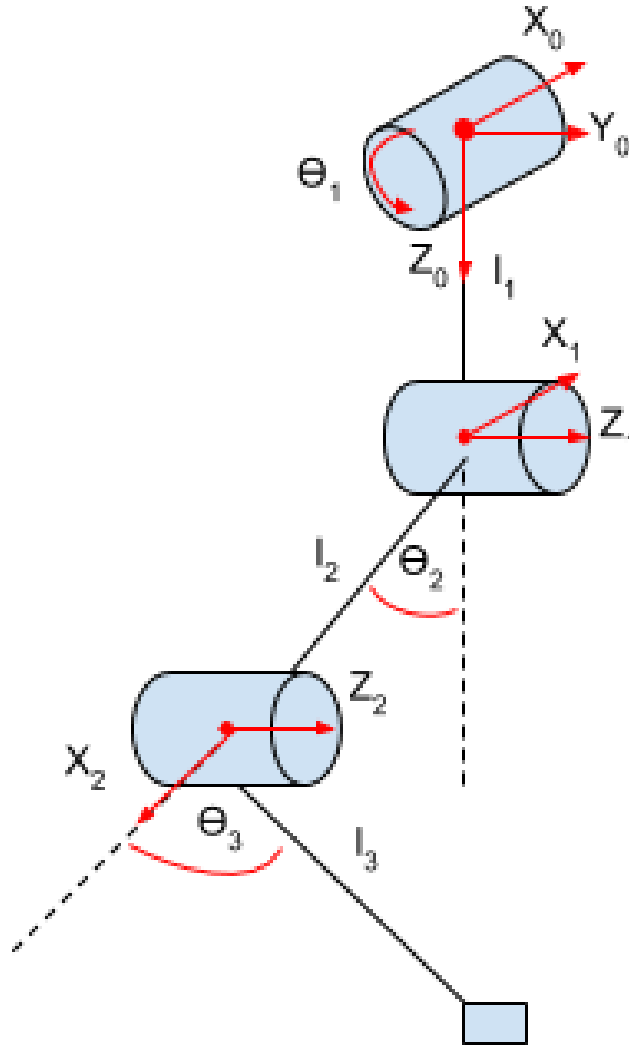

Figure 5.16: Kinematic Chain of Single Leg

$$H = \text{sqrt}(y^2 + z^2) - l_1 \quad (5.3)$$

$$\theta_1 = \text{atan2}(x, z) \quad (5.4)$$

$$\theta_3 = \text{acos}\left(\frac{x^2 + H^2 - l_2^2 - l_3^2}{2 * l_2 * l_3}\right) \quad (5.5)$$

$$\theta_2 = \text{atan2}(x, H) \pm \text{atan2}(l_2 + l_3 * \cos(\theta_3), l_3 * \sin(\theta_3)) \quad (5.6)$$

With the introduction of the 3rd degree of a new analytical solution for inverse kinematics must be derived. The new base frame for an individual leg was also moved to the newly implemented joint. The base frames z-axis is not in the direction of rotation to maintain the same orientation of the x-axis facing towards the front of the robot. The new kinematic chain and frame assignments can be seen in the figure. A standard approach for solving the inverse kinematics for the typical kinematic chain was utilized and the equations can be seen in equations 5.3 to 5.6.  $\theta_1$  is first calculated from the arctangent of the desired  $y$  and  $z$  value. The value  $H$  corresponds to the new height the last two DOF's must travel to reach the setpoint.  $\theta_3$  is calculated from the law of cosines of the triangle. Then  $\theta_2$  is calculated based on the result of  $\theta_3$ .

During testing of the walking gait a decision was made to have the front legs go the opposite direction from the back legs. This helps to maintain a more centered center of gravity with less variance in the center of gravity. The inverse kinematics remain mostly the same.  $\theta_3$  is multiplied by -1 for the front legs. and  $\theta_2$  uses the negative sign for  $\pm$ .



## 5.7 Hardware Redesign

### 5.7.1 Leg Motor Position Changes

As mentioned the legs had to be redesigned to remove the series elastic actuation. The reason behind this was to reduce the amount of chain transmissions between the leg joint and the motor. All legs were made to be direct driven reducing a lot of slop in the system. All of the chain links in the Series Elastic Actuation caused around 10 degrees of unwanted travel in the legs. A rigid leg joint was required to achieve the different walking gaits for the quadruped. In addition, the high ratio gearboxes had a large amount of backlash. These sacrifices were made because of the budget of the project as well as some undesirable tolerance in the SEA. Even if all of the slop in the system were to be accounted for through additional springs, the potentiometers used to measure the leg angles were not accurate enough to measure the amount of torque through angle changes of the SEA. However, this change allowed us to remove a few pounds from the chain used as transmission and also increase running efficiency through removal of transmission inefficiencies.

### 5.7.2 Series Elastic Actuation Removal/Improvements

The spring compliance system was removed from the robot because of a couple of reasons. The current setup of springs adds to the oscillations where the robot

is trying to stay in stability. One of the main factors is that the low tolerance in the mechanical system and low accuracy of the potentiometers used cannot measure the leg deflections in the spring causing the SEA system unusable.

## 6 Results

The goal of this project was to build upon the quadruped built last year in order to create a functioning quadruped platform for future projects. By the end of the project the robot achieved three different types of motion gaits: The crawl gait, the walking gait, and the turning gait. A user who wants to utilize one of these gaits simply has to plug in the number of steps they would like for walking or crawling, and the number of degrees for turning. All of these gaits were able to run without any tether or support and without toppling over.

All the calculations for each step are done by the robot making it intelligent. The robot uses feed-forward to adjust the amount of forces needed at different portions of the gait as well as the motion planning for each step. It uses the designed gait to predict the amount of force needed to apply to the ground. This worked very well in reducing the amount of wobble during crawl and walking gaits.

The third degree of freedom was also implemented on the robot. The team was

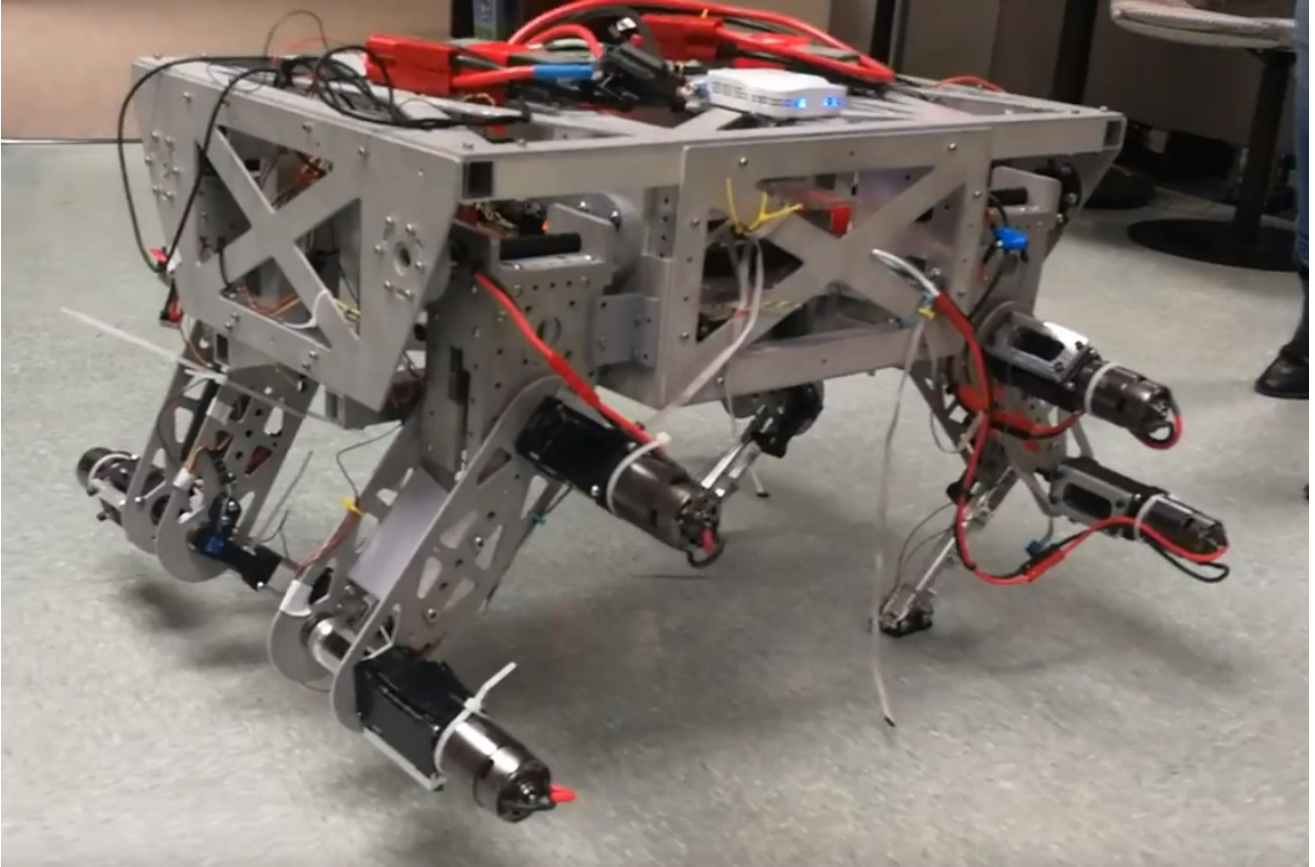

Figure 6.1: Walking Initial Position

able to achieve a fully functional three degree of freedom inverse kinematics as well as the first implementation of a turn gait. It uses a step on two legs to rotate the body of the quadruped 45 degrees without any translation.

## 6.1 Mechanical Analysis

After upgrading most of the structural 3D printed parts with machined parts, the overall chassis and leg connection became much more rigid. This allowed the programming on the gaits easier. There were still many mechanical variables that made the coding harder. A majority of the rigidity of the system was lost

through the four stage VEX Versa planetary gearboxes. It made each leg have a backlash of 3-5 degrees per joint. This rotational tolerance was also doubled through the hex bores made for the axles as they didn't have a perfect fit. Many parts of the chassis could have weight reductions without compromising strength for normal operation of the quadruped.

### 6.2 Crawl Gait

The crawl gait was developed to have all sections of the gait to be statically stable. Although slightly unstable, we were able to achieve a working crawl gait. The fastest stable crawl gait achievable was about 20 seconds per full gait. The full crawl gait moves the robot about ten inches forward. This means the average speed of the crawl gait is 150 ft per hour. The gait movement only required two degrees of freedom on the legs. It was able to move constantly with the center of gravity within the contact points of each feet.

Some of unsteadiness were due to slop in the leg assembly though both the high ratio gear box and some poorly toleranced holes. This slop caused leg placements to be inaccurate which produced some unsuitableness within the system. The slack in each joint causes error to build up over time. This error is in the actual joint position and the ideal joint position. The weight of the robot makes it difficult for the PID controller to quickly correct the error. In practice this can cause a single leg to get dragged, making the robot unstable. The instability is

## 6 Results

minimal and normalizes because of the pause between each step.

The stability of the robot was also significantly improved through changing the leg angles from bending the same direction to symmetrically bending outwards shown below.

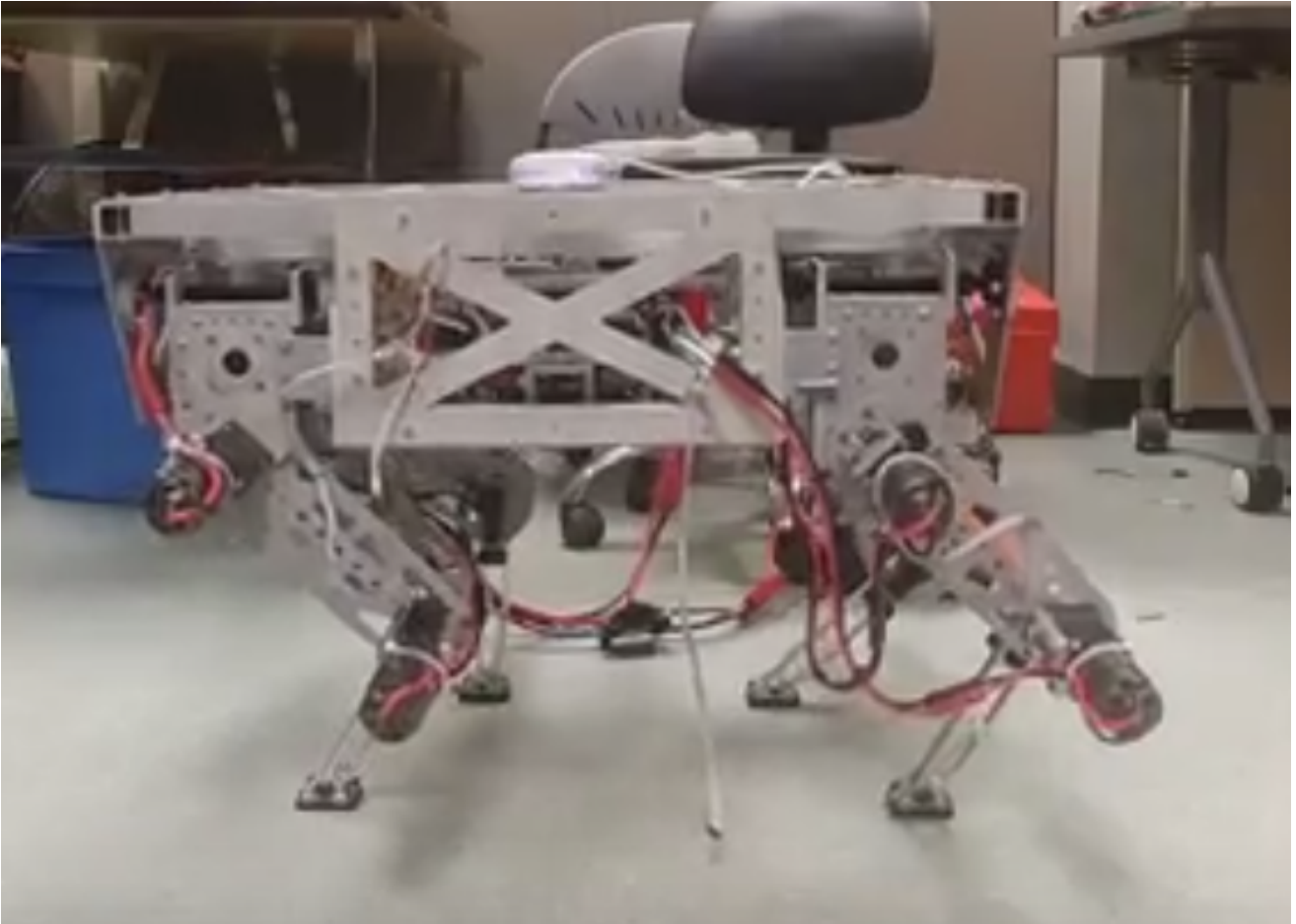

Figure 6.2: Quadruped Old Stance

This change allowed the robot to avoid most of its toggle points in the joints. The toggle points caused a lot of problems including many predicted unsteadiness because of the backlash in the gearboxes. The stance change also allowed the quadruped to make larger strides per step.

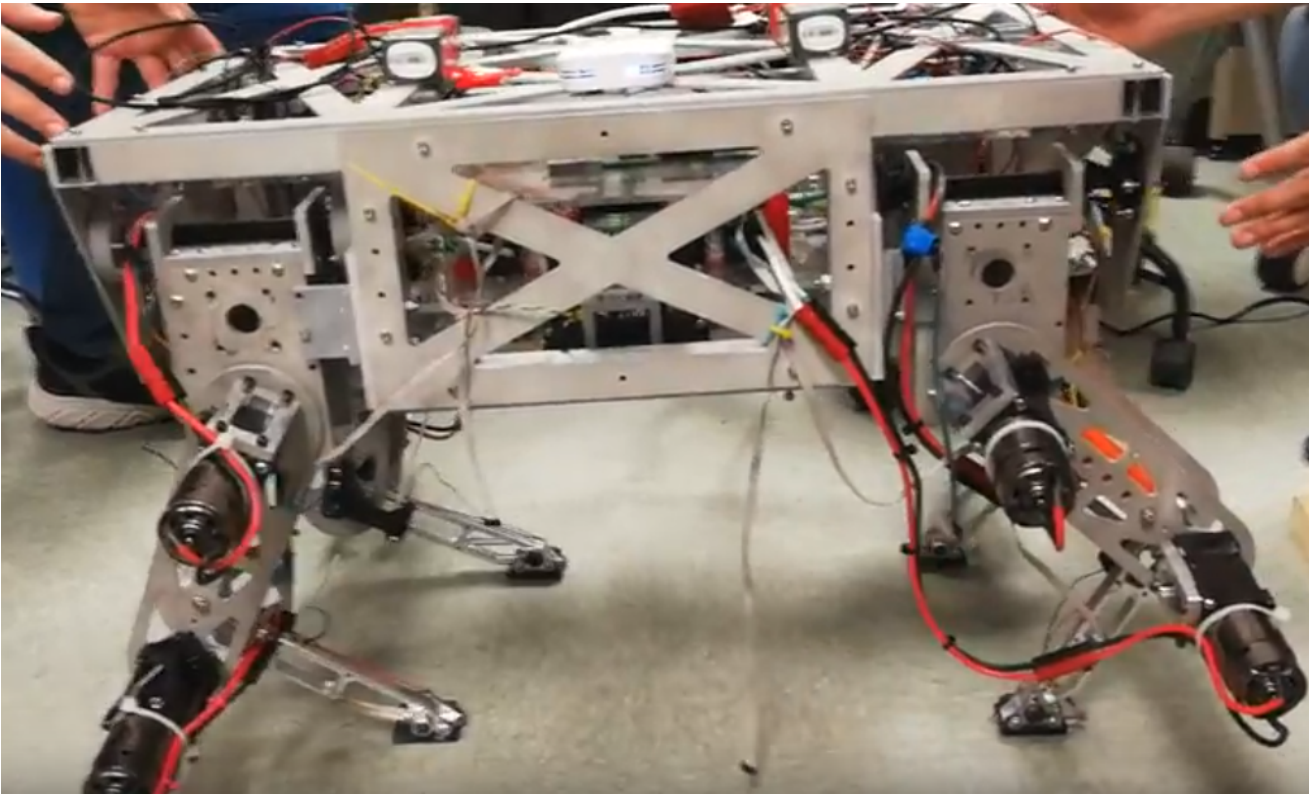

Figure 6.3: Quadruped New Stance

### 6.3 Walk Gait

The walk gait allowed the robot to have much faster transitions from start to end of the gait. This removed some of the inaccuracies shown in the crawl gait. The gait moved two legs at a time so every cycle only takes two steps instead of four from the crawl gait. The quadruped was tuned to walk small steps with a much faster pace. It kept four legs on the ground 75 percent of the cycle and had two legs on the other 25 percent. This was tested walking across the room in the common area of 85 Prescott. The issues with slop in the system in the crawl gait also posed an issue for the walking gait. Each full gait moves a smaller amount than the crawl gait but takes much less time. Using the walking gait the robot can move about 6 inches per seconds, that is 255 ft per hour.

## 6.4 Turn Gait

The turn gait was implemented after installing the third degree of freedom. The shoulder joint on the quadruped allowed the feet to move in three dimensional space. This allowed the quadruped to turn in place. Our turn gait first steps two times in place to get the legs at a good position, then turning the chassis to any degree from the starting position.

However since this gait was the last one implemented and was initially anticipated from the beginning of the project many issues were encountered. The adaptive foot designed in B-term works amazingly well when each leg had two degrees of freedom. However when the foot was designed it was unclear if the team would implement a 3rd degree. So the design is not accommodating. This is currently one of the physical factors limiting the turning gait. In response the team added a small curve to the bottom of the foot. The rounded bottom allows for more contact to be made while the foot is extended out. This is a temporary fix as the team was restricted by time.

The quadruped can in theory turn up to 45 degrees but physical restrictions limit stable turning to about 30 degrees. Since the foot was not designed with the third degree in mind the button also has issues. It is not consistently triggered once the leg is extended out 20 degrees. The third degree of freedom also meant that external forces acted on the system in a different way than initially anticipated. As a result some of the existing structure has started to bend or snap.





Figure 6.4: Temporary Foot Fix

# 7 Recommendations Moving Forward

Since the base of this project is a simple quadruped there are a multiple directions that future projects can go. Given more time and funding, this project can be continued to be improved to have more confidence in its movement gaits. These improvements could include different motor and gearbox combination choices and angular position/speed measurement device changes. Choosing these budget transmission systems and sensors created many challenges to the team. Most of these challenges were patched in software to allow for a decent movement gait.

## 7.1 Potential Improvements

### 7.1.1 Mechanical Redesign

The physical robot has a lot of room for improvements. One area of improvement that cause a lot of issues was the overall slack of the system. Each joint has at

least 3 degrees of freedom. The over-all robot chassis could be designed to be much lighter or for easy dis-assembly. These would be large scale projects that would require some time. The current robot weighs about 40 pounds and is top heavy. Making the chassis lighter would also lower the center of gravity, making the robot more stable. While making the robot easy to disassemble would make the addition and repair of features easier.

### **7.1.2 Leg Redesign**

Each leg of the robot was originally designed to have series elastic actuation. However, in order to move the project forward the team decided to remove the series elastic actuation instead of repair them. Future teams could potentially re-install the mechanisms and make it functional. Future teams could also work to redesign the feet. The team redesigned the feet to allow for adaptive surface contact along one axis. Future teams could take this further so that the feet can adapt to surfaces along any axis.

### **7.1.3 Sensors and Control**

The sensor with the most potential to over improve static and dynamic stability of the robot would be the integration of an IMU. Utilizing the accelerometers on board the IMU, a controller could be made to create dynamic stableness. The crawl gait could be greatly improved by quickly correcting any instability

introduced to the quadruped. The IMU would be even more useful for the walk gait. A controller using IMU data could potentially dynamically balance the quadruped. We are unsure a controller could be developed with just an IMU and the current hardware of the quadruped, but at the least some dynamic balancing could be implemented to create much more stable walking steps and allow longer steps to be taken.

## 7.2 Potential Future Projects

### 7.2.1 Path Finding

Currently the robot's movements have to be pre-programmed prior to running. A potential next step would be to incorporate path-finding so that given an x,y position the robot could find its way. Additional sensors, such as cameras or ultrasonic sensors, should be mounted for obstacle avoidance. An IMU could also be mounted to track movement.

### 7.2.2 User Interface

The purpose of the first MQP was to make a quadruped that could be used by future robotics project. A future project could align themselves with this goal

and focus on creating a user interface for the robot. This would be a computer science project that would require creating a graphic user interface as well as writing callable functions. A user should be able to easily command the robot to go between multiple gaits in the same run. The UI would prove as a great resource for demonstrations of quadruped gaits.

## 8 Conclusion

The project successfully reached all the goals initially set out. The team was able to accomplish unassisted walking and turning gaits without any tethers or support. The code platform was developed to allow for flat ground motion control.

However the team encountered many issues during physical tests. Instead of spending time perfecting each issue we decided to move forward to complete all the tasks set out. This was a compromise the team knowingly made. Given more time we could have fixed and perfected each motion gait. The code aspect of the project has completed gait state machines that could be incorporated into full quadruped trajectory planning. The programming for the quadruped could be improved with upgraded hardware to make the quadruped have a more stable motion. Different electronics selections could have been made to make software developments faster through not having to use Xilinx and FPGA compilers for the central controller.

## 8 *Conclusion*

Even though various hardware upgrades were made for the quadruped, the hardware aspect was still the most limiting factor for further development. The combination of less tight toleranced water jet parts and overly high geared brushed motors limited some gait developments from being perfected.

This project successfully tested and proved methods of creating stable motion gaits. There is a lot of potential for this platform and the team strongly encourages future teams to build upon it to make it valuable tool for future WPI Robotics projects.

## 9 Sources

Hwang, Heeseon, and Youngil Youm. Dynamic Crawl Gait Algorithm for Quadruped Robots. 2008 IEEE/RSJ International Conference on Intelligent Robots and Systems, 2008, doi:10.1109/iros.2008.4650779.

Visioli, Antonio, and Qingchang Zhong. Control of Integral Processes with Dead Time. Springer, 2012.

Hutter, Marco, et al. High Compliant Series Elastic Actuation For The Robotic Leg Scarleth. Field Robotics, 2011, doi:10.1142/9789814374286\_059.

Lv, M., Chen, W., Ding, X., Wang, J., Chen, X. (2014). A new designed quadruped robot with elastic joints. 2014 IEEE International Conference on Automation Science and Engineering (CASE), 1002-1007.

S. Ivaldi et al, Tools for simulating humanoid robot dynamics: A survey based on user feedback. DOI: 10.1109/HUMANOIDS.2014.7041462. (2014).



Liang, Oscar. Quadruped Robot Gait Study. Oscar Liang, 14 May 2016, [oscarliang.com/quadruped-robot-gait-study/](http://oscarliang.com/quadruped-robot-gait-study/).

Simplebotics. Guy Creates Scaled Down Version Of Boston Dynamics' Quadruped Robot. Simplebotics, 21 Apr. 2015, [www.simplebotics.com/2014/10/guy-creates-scaled-down-version-of-boston-dynamics-quadruped-robot.html](http://www.simplebotics.com/2014/10/guy-creates-scaled-down-version-of-boston-dynamics-quadruped-robot.html).

Eckert, Peter, and Auke Ijspeert. Adaptive Foot Design for Small Quadruped Robots. doi:10.3897/bdj.4.e7720.

Prosthetics for Dogs and Other Pets. Prosthetics for Dogs — Artificial Leg for Dog — Animal Prosthetics — MyPetsBrace.com, My Pets Brace, [mypetsbrace.com/prosthetics-for-dogs](http://mypetsbrace.com/prosthetics-for-dogs).

IMU Inertial Measurement Unit. Xsens 3D Motion Tracking, XSENS, [www.xsens.com/tag/imu](http://www.xsens.com/tag/imu)