

LDA-0807

PPM-0807

Morey's Dam Restoration Project  
Hydraulic and Structural Analysis of Morey's Dam with the Implementation of a Fish Passage

A Major Qualifying Project Report:

submitted to the Faculty

of the

WORCESTER POLYTECHNIC INSTITUTE

in partial fulfillment of the requirements for the

Degree of Bachelor of Science

by

---

Yisel Mantilla

---

Bethany Santangelo

---

Michael Butler

Date: December 20, 2007

Approved:

---

Professor Leonard Albano, Major Advisor

---

Professor Paul P Mathisen, Major Advisor

## **Abstract**

This project includes a design for the rehabilitation of a small dam and incorporated fish passage. It also investigates this design processes and elements that must come together for the design of a small dam with a fish passage channel. Requiring analysis in the disciplines of hydraulics, hydrology and structural engineering, the focus of this project was to create a design that specifically suited the site located at the outflow of Lake Sabbatia, on the Mill River in Taunton, Massachusetts.

## Authorship

Bethany Santangelo, Mike Butler, and Yisel Mantilla shared the writing responsibilities of the background of the report. Yisel and Bethany were primarily responsible for the writing represented in the Introduction, Results, and Conclusion sections.

Each team member focused on writing specific sections. Mike Butler was responsible for the work in 3.1 Hydrologic Analysis and 4.1 Hydrologic Analysis. Bethany Santangelo focused on 3.1.4 Fish Passage Hydrology, 3.2 Hydraulic Analysis, 4.1.4. Fish Passage Hydrology, and 4.2 Hydraulic Analysis. Yisel Mantilla focused on 3.3 Structural Analysis and 4.3 Structural Analysis. Yisel Mantilla and Bethany Santangelo shared authorship on 3.4 Cost Analysis and 4.4 Cost Analysis.

---

Yisel Mantilla

---

Bethany Santangelo

---

Michael Butler

# Contents

<b>ABSTRACT</b> .....	<b>I</b>
<b>AUTHORSHIP</b> .....	<b>II</b>
<b>CONTENTS</b> .....	<b>III</b>
<b>LIST OF FIGURES</b> .....	<b>VII</b>
<b>LIST OF TABLES</b> .....	<b>IX</b>
<b>1 INTRODUCTION</b> .....	<b>1</b>
1.1 Site Geography .....	2
1.2 Capstone Design .....	2
<b>2 BACKGROUND</b> .....	<b>4</b>
2.1 Ecology Restoration .....	4
2.2 Hydrology .....	4
2.3 Soil Characteristics.....	5
2.4 Dams .....	8
2.4.1 Types of dams.....	8
2.5 Concrete Gravity Dams .....	8
2.5.1 Forces and Stability Conditions of the Structure .....	9
2.5.2 General Design considerations for Dams .....	10
2.6 Spillway Design & Hydraulics .....	10
2.6.1 Identifying Flow Profiles .....	11
2.6.2 Fish Passage Design .....	14
2.7 Cost Estimating .....	15
2.8 Existing Conditions .....	16
2.9 Implications of Background Information.....	19
<b>3 METHODOLOGY</b> .....	<b>20</b>
3.1 Hydrologic Analysis.....	20
3.1.1 Mill River Watershed Hydrology.....	21

3.1.2	Physical Characteristics .....	22
3.1.3	Meteorological Characteristics.....	30
3.1.4	Fish Passage Hydrology .....	33
<b>3.2</b>	<b>Hydraulic Analysis.....</b>	<b>34</b>
3.2.1	Spillway Hydraulics .....	36
3.2.2	Fish Passage Hydraulics .....	38
<b>3.3</b>	<b>Structural Analysis.....</b>	<b>40</b>
3.3.1	Reinforcement Design for the Structure .....	46
3.3.2	Fish Ladder Analysis.....	48
<b>3.4</b>	<b>Cost Analysis.....</b>	<b>49</b>
<b>3.5</b>	<b>Summary of Methods .....</b>	<b>50</b>
<b>4</b>	<b>RESULTS &amp; ANALYSIS .....</b>	<b>51</b>
<b>4.1</b>	<b>Hydrologic Analysis.....</b>	<b>51</b>
4.1.1	Fish passage Hydrology .....	56
<b>4.2</b>	<b>Hydraulic Analysis.....</b>	<b>57</b>
4.2.1	Tailwater Analysis .....	58
4.2.2	Spillway Analysis.....	59
4.2.3	Fish Passage Hydraulics .....	64
<b>4.3</b>	<b>Structural Design Calculations for the Dam.....</b>	<b>66</b>
4.3.1	Load Calculations.....	66
4.3.2	Structural Analysis of the Fish Ladder .....	70
<b>4.4</b>	<b>Cost Analysis.....</b>	<b>73</b>
<b>4.5</b>	<b>Summary of Results.....</b>	<b>76</b>
<b>5</b>	<b>CONCLUSION &amp; RECOMMENDATIONS .....</b>	<b>80</b>
	<b>WORKS CITED .....</b>	<b>82</b>
	<b>APPENDIX A. HYDROLOGIC ANALYSIS. ....</b>	<b>A</b>
	<b>APPENDIX B. FISH PASSAGE HYDROLOGY.....</b>	<b>R</b>
	<b>APPENDIX C. HYDRAULIC ANALYSIS.....</b>	<b>5-Z</b>
	<b>APPENDIX D. PLANS .....</b>	<b>EE</b>
	<b>APPENDIX E. COST ESTIMATING.....</b>	<b>HH</b>

**MAJOR QUALIFYING PROJECT REPORT PROPOSAL: ..... LL**

**1 INTRODUCTION..... 1**

1.1 Capstone Design Process ..... 1

1.2 Mill River Geography ..... 2

**2 BACKGROUND ..... 3**

2.1 General Purpose of Dams. .... 3

2.1.1 Types of Dams. .... 3

2.1.2 Forces on Embankment Dams. .... 4

2.1.3 Forces in Concrete Dams. .... 4

2.1.4 Forces Combination for Structural Analysis of Dams ..... 4

2.1.5 Settlements ..... 4

2.2 Reconstruction vs. Repair of Dams. .... 5

2.3 Environmental Concerns..... 5

2.4 Fish Ladder ..... 6

2.4.1 Types of Fish Passages. .... 6

2.5 Morey’s Bridge Dam: Existing Conditions ..... 9

2.5.1 DCR Size & Hazard Classification ..... 10

2.6 Pertinent Engineering Data ..... 10

2.6.1 Drainage Area ..... 10

2.6.2 Reservoir..... 10

2.7 Constraints on Mill River Restoration Projects..... 10

**3 METHODOLOGY..... 12**

3.1 Define the Problem and Goals. .... 12

3.2 Assess and analyze existing site conditions..... 12

3.2.1 Literature review ..... 12

3.2.2 Present dam assessment ..... 13

3.2.3 Identify design constraints ..... 13

3.3 Hydraulic Design ..... 13

3.3.1 Dam & Spillway..... 13

3.3.2 Fish Passage ..... 14

3.4 Structural Design ..... 14

3.4.1 Dam & Spillway Structure ..... 14

3.4.2 Fish Passage ..... 14

3.5 Evaluate the Economic Factors. .... 15

**3.6 Write Report..... 15**

**APPENDIX A. MILL RIVER LOCATION & SOIL DATA..... I**

## List of Figures

FIGURE 1. MOREY'S BRIDGE DAM SITE RELATIVE TO TAUNTON, MA.....	2
FIGURE 2. BASIC WATER CYCLE. (UNITED STATES ENVIRONMENTAL PROTECTION AGENCY 2007) .....	5
FIGURE 3. TYPES OF SOIL PRESENTED IN THE SITE .....	6
FIGURE 4. SHASTA DAM IMPOUNDS THE SACRAMENTO RIVER IN NORTHERN CALIFORNIA (MICROSOFT ENCARTA 2007) .....	9
FIGURE 5. EQUILIBRIUM CONDITIONS.....	9
FIGURE 6. SUMMARY OF LOADS ACTING ON A BASIC GRAVITY DAM. ....	10
FIGURE 7. FLOW TYPES. A) UNIFORM FLOW; B) UNSTEADY UNIFORM FLOW; C) STEADY, UNIFORM FLOW; D) UNSTEADY, VARIED FLOW; E) UNSTEADY, VARIED. (NED H. C. HWANG 1996) .....	11
FIGURE 8. FLOW PROFILES. (NED H. C. HWANG 1996).....	12
FIGURE 9. HYDRAULIC JUMP. (STURM 2001) .....	14
FIGURE 10. DENIL FISHWAY SECTION. (QUINN 2007).....	15
FIGURE 11. CURRENT SPILLWAY CONDITION SHOWING GATE HOUSE SUPPORTS. ....	16
FIGURE 12. DEAD MUSSELS ON THE RIVER BED. ....	16
FIGURE 13. TEMPORARY COFFER DAM. ....	17
FIGURE 14. FROM BENEATH THE BRIDGE AND GATE HOUSE. PVC PIPES AND GATE HOUSE SUPPORTS.....	17
FIGURE 15. TEMPORARY COFFER DAM PLAN DRAWING. (PARE CORPORATION 2007) .....	18
FIGURE 16. HYDROLOGIC METHODOLOGY FLOWCHART .....	21
FIGURE 17. LOCATION OF MILL RIVER WATERSHED.....	23
FIGURE 18. AUTOCAD 2007 REPRESENTATION OF MILL RIVER WATERSHED OUTLINE.....	23
FIGURE 19. CN VALUES. (NATIONAL RESOURCE CONSERVATION SERVICE 2004).....	25
FIGURE 20. DIVISION OF LAND USE.....	26
FIGURE 21. HEC-HMS LAYOUT .....	31
FIGURE 22. BASIN CHARACTERISTIC TABS.....	32
FIGURE 23. METEOROLOGICAL CHARACTERISTICS TAB.....	32
FIGURE 24. CONTROL SPECIFICATION .....	32
FIGURE 25. HYDRAULIC ANALYSIS FLOWCHART. ....	35
FIGURE 26. HYDRAULIC CROSS SECTIONS, PLAN VIEW.....	36
FIGURE 27. SHARP CRESTED WEIR (A) AND OGEE SPILLWAY (B). (HWANG, FUNDAMENTALS OF HYDRAULIC ENGINEERING SYSTEMS 1989) .....	37
FIGURE 28. EXAMPLE FISHWAY. (MARYLAND DEPARTMENT OF NATURAL RESOURCES 2007) .....	39
FIGURE 29. STRUCTURAL ANALYSIS FLOWCHART A. ....	40
FIGURE 30. STRUCTURAL ANALYSIS FLOWCHART B.....	41
FIGURE 31. COFFER DAM PLAN VIEW. (PARE CORPORATION 2007) .....	42
FIGURE 32. FORCES ACTING ON DAM.....	43
FIGURE 33. SHEAR DIAGRAM. ....	47
FIGURE 34. DENIL FISHWAY DIMENSION AND HORIZONTAL BAFFLE (SPACING FOR VARIOUS FISHWAY WIDTHS). (ASCE 2003) .....	48
FIGURE 35. EXAMPLE FISHWAY. (MARYLAND DEPARTMENT OF NATURAL RESOURCES 2007) .....	49
FIGURE 36. BASIC DENIL FISHWAY DESIGN ELEMENTS. (ODEH, DISCHARGE RATING EQUATION AND HYDRAULIC CHARACTERISTICS OF STANDARD DENIL FISHWAYS 2003) .....	49
FIGURE 38. MILL RIVER WATERSHED RUNOFF HYDROGRAPH AT MOREY'S BRIDGE DAM FOR PMS .....	52
FIGURE 37. GLOBAL SUMMARY TABLE.....	52
FIGURE 39. DRAINAGE AREA VS. MAXIMUM HISTORICAL FLOWS.....	53
FIGURE 41. MAXIMUM FLOW ASSOCIATED WITH HYDRAULIC ANALYSIS.....	54
FIGURE 40. RAINFALL DATA FROM USWB TP 40 FOR TAUNTON WATERSHED. ....	54
FIGURE 42. HYDROGRAPH ASSOCIATED WITH HYDRAULIC MAXIMUM FLOW.....	55
FIGURE 43. GOOGLE EARTH IMAGE OF TAIL WATER CHANNEL.....	57
FIGURE 44. EXPANSION AND CONSTRICTION COMPARISON, LOW FLOWS. ....	62
FIGURE 45. EXPANSION AND CONSTRICTION COMPARISON, AVERAGE FLOWS. ....	63
FIGURE 46. EXPANSION AND CONSTRICTION COMPARISON, HIGH FLOWS. ....	63
FIGURE 47. DENIL FISHWAY SECTION VIEWS. (ODEH 2003) .....	65
FIGURE 48. FISHWAY HEAD AND DISCHARGE VALUES AT FIRST BAFFLE. ....	65



FIGURE 49. DEAD LOAD .....	66
FIGURE 50. UPSTREAM HYDROSTATIC LOADS.....	66
FIGURE 51. UPLIFT PRESSURE.....	67
FIGURE 52. FISHWAY CROSS SECTION. ....	71
FIGURE 53. COST DISTRIBUTION. ....	75
FIGURE 54. PROPOSED SITE PLAN.....	78
FIGURE 55. DAM REINFORCEMENT.....	79
FIGURE 56. FISH LADDER PLAN. ....	79
FIGURE 57. CURRENT USGS DATA REGARDING THE MILL RIVER AND ITS WATERSHED.....	A
FIGURE 58. LAND USAGE WITHIN THE MILL RIVER WATERSHED. ....	D
FIGURE 59. IMPERVIOUS AREA WITHIN MILL RIVER WATERSHED.....	E
FIGURE 60. HMR-51 ISOPLUVIAL MAP (COMPLETE FIGURES PROVIDED IN DATA FILES).....	F
FIGURE 61. MILL RIVER WATERSHED RUNOFF HYDROGRAPH AT MOREY'S BRIDGE DAM.....	Q
FIGURE 62. HISTORICAL DAILY MEANS DATA. (UNITED STATES GEOLOGIC SURVEY (USGS) 2007) .....	R
FIGURE 63. HDM CONTINUED .....	S
FIGURE 64. HDM CONTINUED. ....	T
FIGURE 65. HDM CONTINUED. ....	U
FIGURE 66. SPILLWAY CREST CONDITIONS, UNDER ALL ANALYZED FLOW RATES. ....	CC
FIGURE 67. SPILLWAY CREST CONDITIONS, FLOW RATES <350 CFS.....	DD
FIGURE 68. FISHWAY PLAN AND CROSS SECTIONAL VIEWS. ....	EE
FIGURE 69. PROPOSED SITE PLAN.....	FF
FIGURE 70. DAM REINFORCEMENT.....	GG
FIGURE 71. DAMS LOCATED ALONG THE MILL RIVER. ....	2
FIGURE 72. FORCES ACTING ON CONCRETE DAMS.....	4
FIGURE 73. MUSSELS DOWNSTREAM OF THE DAM. ....	6
FIGURE 74. DENIL FISHWAY .....	7
FIGURE 75: PLAN VIEW OF VERTICAL SLOW FISHWAY.....	8
FIGURE 76. MILL RIVER LOCATION. ....	9
FIGURE 77. SPILLWAY CONDITION BELOW THE GATEHOUSE. ....	9
FIGURE 78. DOWNSTREAM VIEW OF CURRENT SPILLWAY STRUCTURE. ....	10
FIGURE 79. COFFER DAM.....	11
FIGURE 80. MOREY'S BRIDGE DAM.....	I
FIGURE 81. BEDROCK GEOLOGY MAP A. (USDA SOIL CONSERVATION SERVICE 1978) .....	II
FIGURE 82. BEDROCK GEOLOGY MAP B. (USDA SOIL CONSERVATION SERVICE 1978) .....	III

## List of Tables

TABLE 1. PORTION OF TABLE 8 OF BRISTOL COUNTY SOIL SURVEY, NORTHERN PART.....	6
TABLE 2. PORTION OF TABLE 10 OF BRISTOL COUNTY SOIL SURVEY, NORTHERN PART.....	7
TABLE 3. PORTION OF TABLE 11 OF BRISTOL COUNTY SOIL SURVEY, NORTHERN PART.....	7
TABLE 4. PORTION OF TABLE 12 OF BRISTOL COUNTY SOIL SURVEY, NORTHERN PART.....	7
TABLE 5. PORTION OF TABLE 13 OF BRISTOL COUNTY SOIL SURVEY, NORTHERN PART.....	7
TABLE 6. WEIGHTED CN VALUE DETERMINATION .....	28
TABLE 7. PROBABLE MAXIMUM PRECIPITATION VALUES FOR SOUTHEASTERN MA.....	30
TABLE 8. HYDRAULIC EQUATIONS USED IN ANALYSIS.....	38
TABLE 9. SUMMARY OF STRUCTURAL EQUATIONS. ....	44
TABLE 10. AREAS, WEIGHTS, AND DIMENSIONS OF REINFORCING BARS .....	48
TABLE 11. SUMMARY OF FISHWAY DESIGN FLOWS.....	57
TABLE 12. TAIL WATER CHANNEL DATA. ....	58
TABLE 13. MANNING'S EQUATION DATA FOR TAIL WATER.....	59
TABLE 14. SPILLWAY EQUATION VALUES. ....	59
TABLE 15. MANNING'S EQUATION VALUES AT SPILLWAY TOE. ....	60
TABLE 16. HYDRAULIC JUMP CALCULATIONS.....	61
TABLE 17. VELOCITIES AND DEPTHS AT CREST. ....	64
TABLE 18. SUMMARY OF ALL THE LOADS RESULTS** .....	68
TABLE 19. SUMMARY OF THE LOADS OBTAINED FROM ANALYSIS.....	72
TABLE 20. COST ESTIMATE WORKSHEET. ....	74
TABLE 21. ARBITRARY COORDINATES FOR OUTLINE OF MILL RIVER WATERSHED.....	B
TABLE 22. FLOWS GREATER THAN 230 CFS. ....	V
TABLE 23. FLOWS GREATER THAN 350 CFS. ....	W
TABLE 24. FLOWS LESS THAN 33 CFS. ....	X
TABLE 25. FLOWS LESS THAN 15 CFS.....	Y
TABLE 26. TAIL WATER CONDITIONS .....	5-Z
TABLE 27. SPILLWAY CREST CONDITIONS, WITH SPILLWAY EQUATION.....	5-AA
TABLE 28. SPILLWAY TOE CONDITIONS. ....	BB
TABLE 29. COST WITH SIMULTANEOUS CONSTRUCTION OF FISHWAY AND DAM. CON'T ON NEXT PAGE. ....	HH
TABLE 30. COST OF DAM CONSTRUCTION.....	II
TABLE 31. COST OF FISHWAY CONSTRUCTION. ....	JJ

## 1 Introduction

Dams have been a vital structure to society, erected for reasons of both energy production and flood protection. Due to the large volumes of water that pass through river systems, large amounts of energy can be produced through hydroelectric power. Large volumes of water can also create public safety hazards through flooding. By creating a reservoir upstream with storage space, a dam enables society to protect communities along river systems against flooding, while harnessing the energy carried in the water to provide electricity to these communities.

While dams are functional and important structures, they can also impact the environment negatively. A major environmental impact of dams is the fact that they create a barrier to native anadromous fish species, who must migrate upstream to spawn and downstream to feed. Dwindling fish populations due to these migration barriers have effects on habitats up and downstream in these rivers, and impact the economy negatively through poor fishing conditions. In the past, dams were constructed with only the flood protection and energy production functions in mind, and without these types of ecological factors taken into consideration. As a result, native anadromous populations have declined. Recent dam reconstruction projects have begun to take these kinds of environmental concerns into account.

Many dams were built during the industrial revolution to provide power to factories. Communities have grown along the rivers, in the areas where flood protection is provided by these aging dams. Many of these dams are around 100 years old, and their deteriorating conditions presents serious public safety threats in the event of floods.

Many dams in Massachusetts were built during the industrial revolution and large communities have grown in the areas downstream of these dams. Massachusetts has 2,917 dams as of 2003, many of which are deemed unsafe by the Massachusetts Department of Conservation and Recreation. (Association of Dam Safety Officials 2007) These unsafe conditions create high risk situations where a flood caused by dam failure could destroy communities downstream.

Morey's Bridge Dam in Taunton, Massachusetts is an example of a dam currently in an unsafe condition with a large community downstream. Through recent dam inspection reports, it has been deemed to have a high hazard potential. (Massachusetts Department of Fish and Wildlife 2007) This dam is also an obstruction to anadromous species. Specifically, the anadromous alewife (a species of river herring) is prevented from spawning in the quiescent lacustrine habitat of Lake Sabbatia.

The goal of this project was to explore the processes and analysis required to design a small dam and fish passage at this location. The project involved studying the hydrology of the area to identify the volume of water passing through the Morey's Bridge Dam site, and designing a dam that would provide adequate flood protection to downtown Taunton. Through hydraulic and structural design, a small overflow dam was designed to fit into the site. To address the environmental concerns of alewife passage to Lake Sabbatia, a fish passage was designed to be built into the dam. Due to time constraints, this process involved making assumptions where

adequate information was not available, and creating a final design that incorporated the preliminary findings from each discipline. The final design reached through this project was sufficient based on the information available; however more detailed information on the site would allow for further refinement of the design. Areas where the design could benefit from further refinement were identified and discussed in the Conclusions and Recommendations section.

## 1.1 Site Geography

Morey's Bridge Dam is located on the southern shore of Lake Sabbatia in the city of Taunton, Bristol County, in the state of Massachusetts. The dam is in the latitude of  $41^{\circ} 56' 02.684''$  N and in the longitude of  $71^{\circ} 06' 28.348''$  W on the Taunton USGS Quadrangle. The dam's spillway is located under Morey's Bridge, which passes traffic along Bay St. In terms of the implications due to its location, the site is a primary means of traffic flow from the city of Taunton to Interstate-495. Figure 1 illustrates the location of the Morey's Bridge Dam site, located upstream of Taunton, MA.

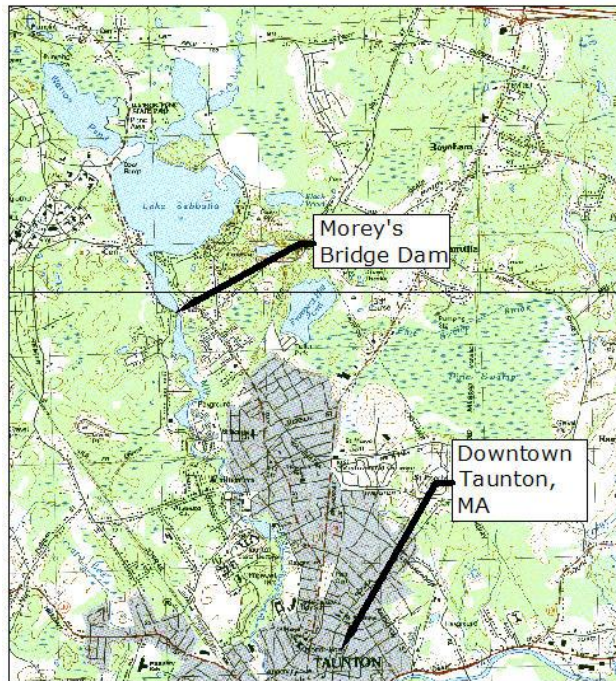

Figure 1. Morey's Bridge Dam Site Relative to Taunton, MA.

## 1.2 Capstone Design

The concept of a Capstone Design project, as defined by the American Society of Civil Engineers is one that incorporates the application of analysis and real world concerns into a final design product. This project meets the capstone design requirements by finding a solution that meets the requirements of economic constraints, public safety constraints, environmental and hydraulic requirements of the site, and constructability issues.

By applying realistic engineering design considerations (economic, environmental, sustainability, ethical, health and safety, and social concerns), the resulting design was a solution that fit into the community as more than just another piece of infrastructure.

The environmental and sustainability part of the requirements were addressed through the fish passage design and the design of the height of the dam. Controlling the water depth of Lake Sabbatia has a direct impact on the water quality of the lake. Sustainability issues were also addressed through the design of the fish passage; native populations must have access to appropriate breeding habitats to maintain healthy breeding populations. This concept addresses sustainability issues by seeking to provide native populations with the access to breeding grounds, resulting in conditions that favor healthy populations.

Health and safety issues were relevant in the hydrologic and structural stability studies. This ensured that in the case of extreme conditions, the structure could prevent massive flooding of highly developed downtown areas. This also applies to the social requirements of the project. Socially, it was very important to maintain the downtown area of Taunton, and make it a place where the population could feel safe downstream of the dam. The structure was also designed to maintain a reservoir elevation (Lake Sabbatia) that would allow the local community to enjoy the lake recreationally.

This project also fit the capstone requirements through a cost estimating model. A cost estimating model was produced to find a price for the final design based on selected materials, size, and the amount of man-hours required to produce the design. This section addresses the economic constraints by creating a base price for the design that can be either simplified to decrease cost or embellished on if there are funds exceeding the budget for the design.

Ethical concerns for the project were addressed through construction methods that would preserve the local ecosystem, and provide a dam that was both functional and welcomed by the local community.

## 2 Background

A balanced and methodical design approach incorporates elements from many different areas. This section highlights important areas of information for the design. The scope of this information ranges from broadly applied design equations to site specific elements.

### 2.1 Ecology Restoration

Restoration ecology is the scientific study of renewing or remediating a degraded or destroyed ecosystem through active human intervention. The Society for Ecological Restoration (SER 2004) defines this topic as “an intentional activity that initiates or accelerates the recovery of an ecosystem with respect to its health, integrity, and sustainability. Ecological or ecology restoration refers to the discipline of restoration ecology. In the ecological restoration field practice there are many restoration projects included; some of these projects are: reforestation, removal of non-native species of disturbed areas, reintroduction of native species, and habitat and range improvement for targeted species. Natural ecosystems provide human society with food, fuel, and timber, but their services also involve environment safety and conservation activities such as air and water purification, climate regulation, regeneration of soil fertility, and conservation of existing viable habitat and restoration of degraded or affected habitats.

Restoration of degraded habitats is different from the conservation of an existing viable habitat. The conservation of an existing viable habitat refers to the effort made to keep the habitat in the actual or similar condition without any disturbance; it also deals with the prevention of species extinction on the existing ecosystem. On the contrary, restoration of degraded habitats implies a jump start to a natural recuperative process of the ecosystem. This reparation process starts with a target that is usually the state that needs to be strived on the site. The Morey’s Bridge Dam project is one that seeks to restore this recuperative process of the area by repairing the current dam such that it incorporates a fishway which will allow the native species to restore their habitat naturally.

### 2.2 Hydrology

Hydrological analysis on a given site investigates the manner in which the natural water cycle process can effect construction of structures such as dams. Hydrologic analysis incorporates concerns such as possible storm events, rainfall accumulation, and the manner of upstream flow contributions. Figure 2 shows how the water cycle proceeds in a systematic fashion.

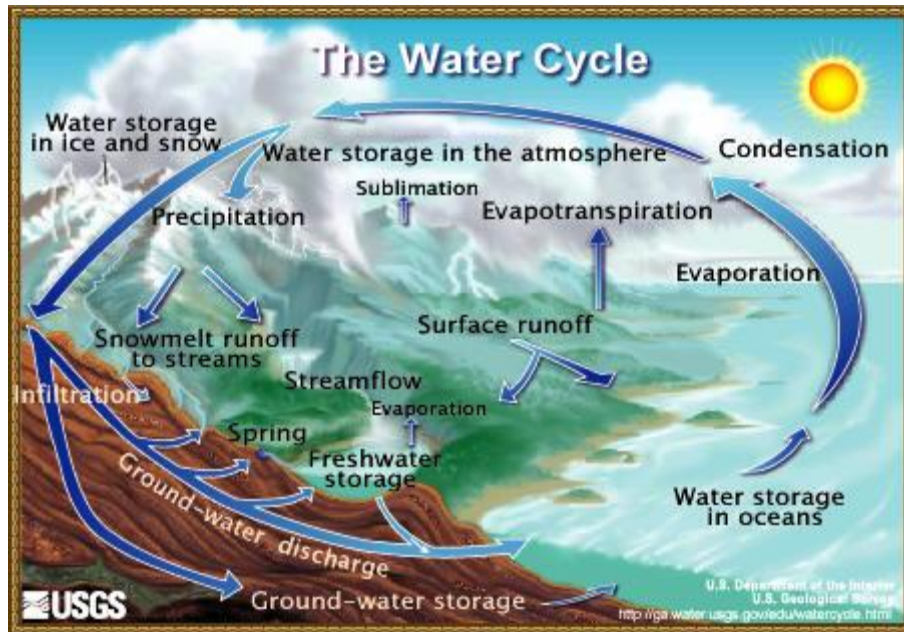

Figure 2. Basic Water Cycle. (United States Environmental Protection Agency 2007)

## 2.3 Soil Characteristics

The soil characteristics of the site were found in the soil survey of the northern side of Bristol County, Massachusetts(1978), provided by the United States Department of Agriculture, Soil Conservation Service, in cooperation with Massachusetts Agricultural Experiment Station.

For our project, sheets 12 and 13 of the maps section of this soil survey were used to identify the type of soil presented in the site. According to this information Table 8-Building Site Development, Table 10-Construction Materials, Table 11-Water Management, Table 12-Recreational Development, Table 13-Wildlife Habitat Potentials, Table 14- Engineering Properties and Classification, and Table 15-Physical and Chemical Properties of Soils were used. Highlights from these tables are shown in the following abbreviated tables.



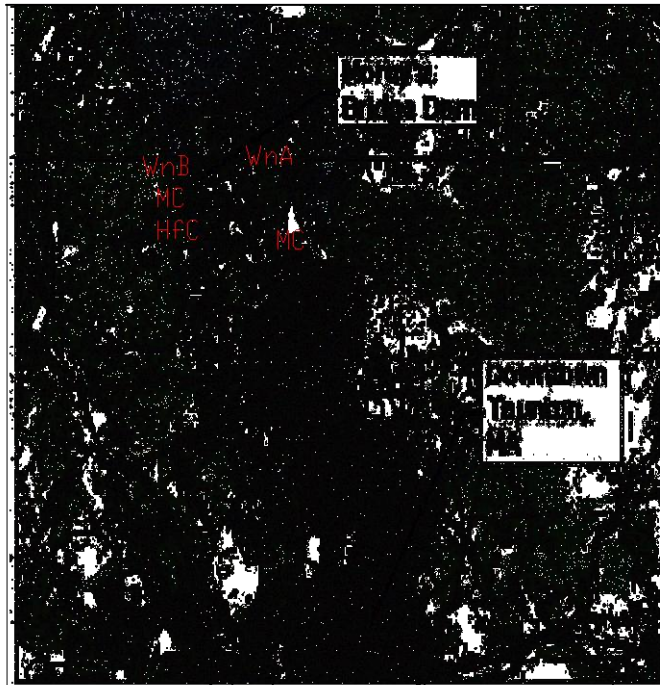

Figure 3. Types of Soil Presented in the site

Table 1. Portion of Table 8 of Bristol County Soil Survey, northern part

Soil Name and Map Symbol	Shallow Excavations	Dwellings without Basements	Dwellings with Basements	Small Commercial Buildings	Local Roads and Streets	Lawns and Landscaping
Hinckley-HfC	Severe: small stones, cutbanks cave	Moderate: slope	Moderate: slope	Severe: slope	Moderate: slope	Moderate: slope
Medisaprists-MC	Severe: small stones, cutbanks cave	Moderate: slope	Moderate: slope	Severe: slope	Moderate: slope	Moderate: slope
Windsor-WnA	Severe: cutbanks cave	Slight	Slight	slight	Slight	Severe: too sandy,drougthy
Windsor-WnB	Severe: cutbanks cave	Slight	Slight	Moderate: slope	slight	Severe: too sandy,drougthy



**Table 2. Portion of Table 10 of Bristol County Soil Survey, northern part.**

Soil Name and Map Symbol	Road fill	Sand	Gravel	Topsoil
Hinckley-HfA, HfB, HfC	Good	Good	Good	Poor: too sandy, Area reclaim
Medisaprists- MC	Fair: large stones.	Good	Good	Poor: large stones, too sandy.
Windsor-WnA, WnB	Good	Good	Poor: excess fines	Poor: too sandy.

**Table 3. Portion of Table 11 of Bristol County Soil Survey, northern part**

Soil Name and Map Symbol	Pond reservoir areas	Aquifer-fed excavated ponds	Drainage	Irrigation	Terraces and diversions	Grassed waterways
Hinckley-HfA, HfB, HfC	Slope, seepage	No water	Not needed	Slope, droughty, fast intake	Slope, too sandy	Slope, droughty
Windsor-WnA, WnB	Seepage, slope	No water	Not needed	Slope, droughty, fast intake	Piping, slope, too sandy.	Droughty, slope.

**Table 4. Portion of Table 12 of Bristol County Soil Survey, northern part**

Soil name and map symbol	Camp areas	Picnic areas	Playgrounds	Paths and Trails	Golf fairways
Hinckley-HfC	Moderate: slope	Moderate: slope	Moderate: slope	Slight	Moderate: slope
Windsor-WnA, WnB	Moderate: too sandy	Moderate: too sandy	Severe: too sandy	Moderate: too sandy	Severe: too sandy, droughty

**Table 5. Portion of Table 13 of Bristol County Soil Survey, northern part**

Soil Name and map symbol	Grain and seed crops	Grasses and Legumes	Wild herbaceous plants	Hardwood trees	Coniferous plants	Wetland plants	Shallow water areas	Openland wildlife	Woodland wildlife	Wetland wildlife
Hinckley-HfC	Poor	Poor	Fair	Poor	Poor	Very poor	Very poor	Poor	Poor	Very poor
Medisaprists- MC	Poor	Poor	Fair	Poor	Poor	Very poor	Very poor	Poor	Poor	Very poor
Windsor-WnA, WnB	Poor	Poor	Fair	Poor	Poor	Very poor	Very poor	Poor	Poor	Very poor

## **2.4 Dams**

Dams are concrete or earth barriers built across a drainage course to impound water that creates lakes called reservoirs. They provide flood control, fresh water storage, and hydroelectric power between other benefits. Dams are grounded on abutments, right abutment on the right side of the dam and left abutment on the left side, and are supported by foundations, which may be pervious or impervious depending on the type of dam used.

### **2.4.1 Types of dams**

Once the required height of the dam has been set by the hydrologic and hydraulic analysis, the dam type can be selected. As mentioned before a dam can be classified as a concrete dam or an earth dam. A concrete dam consists of a cast in place massive concrete structure between the two abutments. There are three principal types of concrete dams; they are: concrete gravity dams, concrete arch dams, and concrete buttress dams. The gravity or mass concrete dams require a site where there is hard rock at or near the surface, the depth of soft material above the rock should not exceed 20 ft, and the rock should be able to support 8 to 10 tons per square foot. Gravity dams are particularly well suited where the length of the crest of the dam is at least five times its maximum height. This type of dams is used where a height of less than 40 ft is required. These characteristics made the concrete gravity dam a feasible selection for Morey's Bridge Dam's restoration project

## **2.5 Concrete Gravity Dams**

Gravity dams are classified as solid, hollow, overflow or non-overflow. The selection of the type of dam for a specific project depends on the conditions. Hydrostatic pressures from the reservoir and tail water loads, nappe forces in case there is an overflow spillway, and uplift pressures and loads from the soil, foundation or earthquake effects are all taken into consideration when selecting the type of dam. A gravity dam's stability is secured by designing its shape and size such that it resists overturning, sliding and crushing at the toe. Gravity dams are considered one of the most confident as far as they are situated in a suitable site and over a carefully designed foundation. For this type of dam, an impervious foundation with high bearing strength is recommended. The type of material used for the dam also depends on the loads that have to be resisted by the structure; the material has to provide the strength needed to resist the forces applied. There exist gravity dams constructed out of wood, earth, and concrete. However, concrete gravity dams have proved to be more stable, and secure than the rest. An example of a concrete gravity dam is shown in Figure 4.

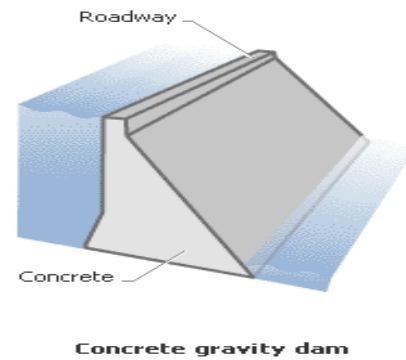

Figure 4. Shasta Dam impounds the Sacramento River in northern California (Microsoft Encarta 2007)

Concrete gravity dams usually have a triangular shape; however the design of a concrete gravity dam depends on the purpose of the structure and the configuration of the site where the structure will be placed. The design of a concrete dam involves an extensive range of disciplines and technical professionals such as geologists, environmental engineers, seismologists, geotechnical engineers, hydraulic engineers, computer analysts, cost analysts, and mechanical and electrical engineers. The overall design of the structure is made in a team composed by all these professionals, whom interchange data and analysis with each other to get a final and unique design that meets the requirements and purposes stated at the beginning of a project.

### 2.5.1 Forces and Stability Conditions of the Structure

Forces acting on a structure are usually classified as internal and external forces. Internal forces such as stress exist within the member because molecular resistance of the material. External forces act at the boundary of the member's structure, such as hydrostatic forces, weight supported by the structure, nappe forces, earthquake and wind forces or loads, and any other force applied to the structure.

In any structural analysis of a member the first step after the calculation of the forces acting on the structure would be the stability or equilibrium analysis of the structure. Through a stability analysis, the structure is determined to be stable or unstable. In order for a structure to be stable, the external forces applied to the members have to meet the six equilibrium conditions listed below in Figure 5. A representation of the forces acting on a dam's structure is shown below in Figure 6.

$\sum F_x = 0$
$\sum F_y = 0$
$\sum F_z = 0$
$\sum M_x = 0$
$\sum M_y = 0$
$\sum M_z = 0$

Figure 5. Equilibrium conditions.

Although a structural design meeting these conditions is considered to be in equilibrium, its stability must be checked according to engineering design codes and regulations. In this design, the American Concrete Institute Code (ACI), and the Army Corp of Engineers design standards were used for the stability analysis of the structure.

## 2.5.2 General Design considerations for Dams

In the design of a dam structure stability criteria for a particular loading combination depend upon the foundation of the structure, site geology, and the method of analysis used. This design is also based on a series of assumptions, which have been used on previous similar structures under similar loading conditions. The basic requirement for the stability analysis of the structure subjected to static loads is that force and moment equilibrium be maintained without exceeding the limits of concrete and concrete/foundation interference. This means that the allowable unit stresses for concrete and foundation materials should not be exceeded.

Through the design of the dam considerations regarding internal stresses in concrete should be taken. In the majority of the cases the stresses on the body of a gravity dam are relatively low, but in cases where stress is a concern it is necessary to follow the codes, requirements and considerations to be included in the design. For example, ACI 318 specifies that the ultimate shear strength of concrete along a pre-existing crack in monolithically cast concrete is 1.4 times the normal stress on the crack, and that shear failure of intact concrete is governed by the tensile strength of concrete normal to the plane of maximum principal axis tension. Another example is the Reinforcement Design Standards of the Army Corps of Engineers, USACE EM 1110-2-2104.

In this type of structure (concrete gravity dam), it is always expected that earthquakes will induced stresses that will exceed the strength of the materials. For this reason, earthquake analysis should be included in the static and dynamic analysis of the structure.

According to the Army Corp of Engineer, in the design of a concrete gravity dam the tensile strength of rock- concrete interface should be assumed to be zero. Small gravity dams are usually constructed on impervious soil foundations. Pervious foundations consists of sands, gravels and alluvial deposits, which increases the under seepage effects and the any force caused by the seepage. In hydro electric dams under seepage may result economic, but on gravity dams under seepage affects the stability of the structure. This is the reason why is recommended an impervious foundation for this relatively small hydraulic structures.

## 2.6 Spillway Design & Hydraulics

There are many types of spillway structures, most involving either a gate to control the discharge and elevation of both the reservoir and tail water. On large reservoirs, the gate

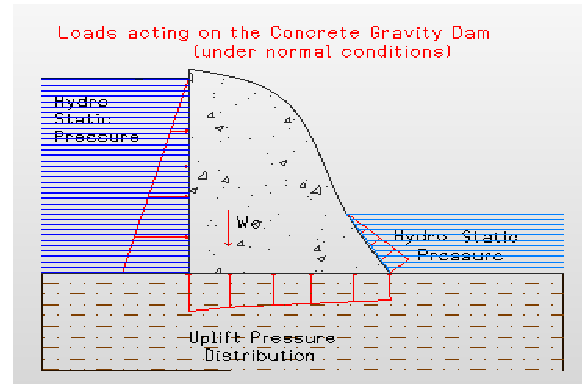

Figure 6. Summary of loads acting on a basic gravity dam.

structure is most common for the spillway, as the gate offers the most control on discharge flow rates, and can be adjusted to handle high or low flow situations.

The overflow spillway, which is a spillway design typical to the Northeast, is essentially a large weir that spans a river. The height of this weir dictates the upstream elevation of the reservoir. This type of spillway not only fits well into the landscape of the site, it is also the most inexpensive option, requiring no power or gate apparatus.

Open channel hydraulic analysis is based on analyzing characteristics of water flow such as depth, velocity, and flow rate, and the relationships among these parameters through given cross sections of the channel. Relationships are analyzed through equations such as Manning's Equation, Froude number, and energy balances. Through identifying relationships between the depth, velocity, flow rate, and cross sectional area, flow profiles can be assigned to each cross section to identify the nature of the flow through that cross section. This is the basis of predicting whether a flow will be rapid and shallow (termed supercritical flow) or slow and deep (termed subcritical flow). Incorporating barriers such as weirs and channel constrictions and expansions have impacts on the flow through the changes in cross sectional areas.

### 2.6.1 Identifying Flow Profiles

Flow conditions can be identified through uniform flow, gradually varied flow, or rapidly varied flow. Figure 7 shows different types of flow, and how they can be characterized. In an application such as a spillway, flow type C fits the profile. Flow type B would characterize flow travelling down the spillway structure and through the tail water channel, and flow type E would characterize a hydraulic jump, which typically occurs somewhere near the toe of spillway structures.

Cross Sectional area, velocity, and flow rate are all related through the following equation.

$$Q = VA$$

The cross sectional dimensions of a channel have a great impact on the velocity and depth of the water passing through it. Though flow rate remains constant throughout a channel, velocity and cross sectional area of the water varies. As one increases, the other will decrease.

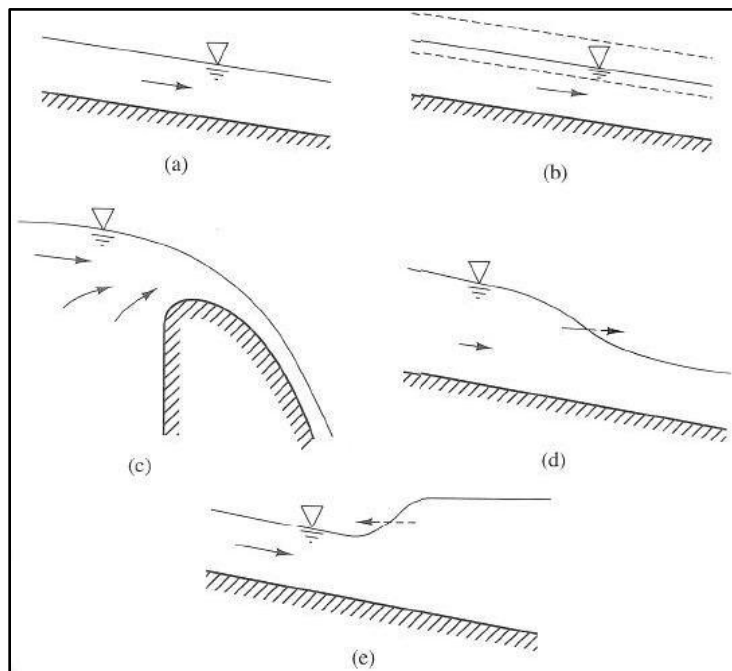

Figure 7. Flow Types. a) uniform flow; b) unsteady uniform flow; c) steady, uniform flow; d) unsteady, varied flow; e) unsteady, varied. (Ned H. C. Hwang 1996)

Figure 7 is a rough guide to characterizing flow types. More accurate analysis of flow depths and velocities will yield flow profiles, as shown in Figure 8. These profiles characterize how the surface elevation of an open water channel fluctuates as the flow changes from one regime to another. Changes between flow regimes are identified through the application of a series of equations. Values of Manning's Equation, Froude number, and critical depth are all found to put the flow into a profile type.

### Manning's Equation and Normal Depth

$$Q = \frac{1.49}{n} R^{2/3} S_0^{1/2}$$

Normal depth is the depth that would be expected in a channel under uniform flow conditions. This equation is used to relate the flow rate (Q), cross sectional area, and channel slope. The variable R is used to express the ratio of the wetted perimeter and cross sectional area of the water, which takes the water depth and channel base width parameters into consideration. The normal depth found through this equation is compared to the critical depth to characterize whether the normal water surface elevation is above or below the critical water surface elevation. This is the first step towards identifying whether the flow is in a state of sub or supercritical flow. Manning's equation also takes head losses into account through the n, the Manning's roughness coefficient. This value is based on experimentally determined head loss factors based on the materials of the channel boundaries. For example, a channel constructed of concrete would have a different n value than a channel of natural pebbles, grasses, or silt. The n values also vary with the condition of the channel material: good, fair or poor. Materials in poor condition have greater n values than those in good condition.

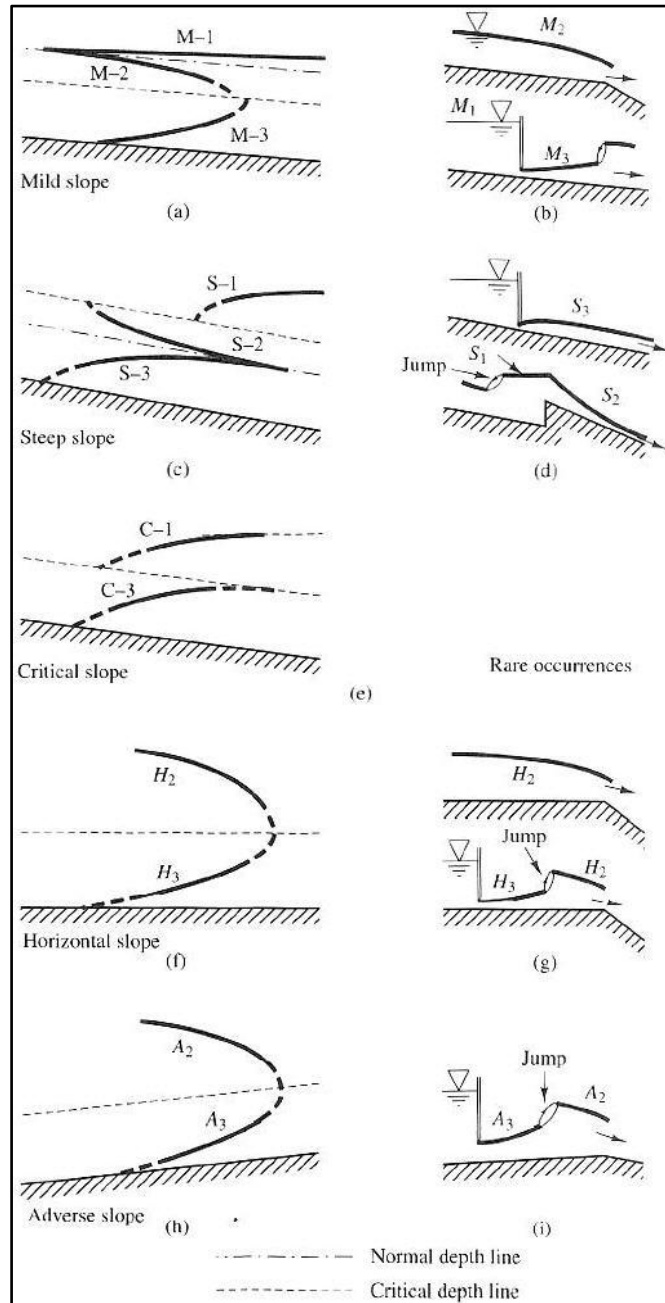

Figure 8. Flow Profiles. (Ned H. C. Hwang 1996)

### Critical Depth

$$y_c = \sqrt[3]{\frac{q^2}{g}}$$

Critical depth is the water surface elevation that acts as the boundary between slow, deep water and shallow, fast flow. This calculation is a function of the flow rate and the channel base width, expressed through  $q$ , which is the unit flow rate, and of gravity which is expressed as  $g$ .

### Froude Number

$$F_r = \frac{V}{\sqrt{gy}}$$

The Froude number is an expression of the momentum versus the force of gravity. A Froude number less than unity ( $F_r < 1$ ) expressed subcritical flow, where the forces of gravity dominate the flow regime. A Froude value greater than unity ( $F_r > 1$ ) expresses supercritical flow, where the velocity and momentum of the water create a flow regime where the flow is shallow and fast. A Froude value of 1 is an unstable, uniform flow condition. Froude values are the basis of analysis for much of the spillway flow, where flow regimes are expected at certain cross sections of the channel, and Froude values are used to find flow velocities and depths that can satisfy regime requirements.

### Energy Balance

$$V_2 = \sqrt{\frac{\left(2g \left[\frac{V^2}{2g} + y_1 - y_2 + z_1 - z_2\right] + CV_1^2\right)}{(1 + C)}}$$

The energy balance is used to identify flows where the channel characteristics have a significant influence on the flows through head loss. This equation is an adaptation of the conservation of energy, where energy in the approaching flow is either carried through to the tail water in a different form (perhaps through varied depths or velocities) or some of it is dissipated through head loss due to friction.

### Hydraulic Jump

$$d_2 = \frac{1}{2}d_1\sqrt{1 + 8F_r^2} - 1$$

The hydraulic jump is a rapid regime change from supercritical to subcritical flow, where much energy is dissipated through turbulence in the transition. Frequently, hydraulic jumps occur near the toe of a spillway, where the energy of the supercritical discharge coming down the spillway is rapidly changed to subcritical flow. This is largely a factor of the change in slope, from the steep slope of the spillway face to the gradual slope of the tail water channel. The above equation was developed using a ratio of initial ( $y_1$ ) and subsequent ( $y_2$ ) depths. This equation, however, does not prove that a hydraulic jump occurs. If tail water conditions inhibit



the natural transition, the subsequent depth and location of the hydraulic jump can be inaccurate. The hydraulic jump subsequent depth must be compared to tail water conditions determined through Manning's equation or the energy equation to accurately predict the location of the jump. Figure 9 shows the transition from initial to subsequent depth with energy dissipation.

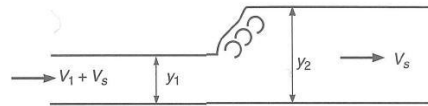

Figure 9. Hydraulic Jump. (Sturm 2001)

## 2.6.2 Fish Passage Design

Fish passage structures are designed to allow species to pass barriers such as dams or areas of turbulent flow, so that they can migrate upstream to spawn. This is accomplished by providing a channel where water velocities are low enough that the target species is able to swim upstream. The water is slowed by a series of obstructions within the fishway channel. These structures are installed at sites such as dams because the velocities and slope at the spillway are too high for native species to pass. As such, these structures are designed with dimensions and flow characteristics unique to the target species to be passed.

A common setup of fishway channels is a channel with a gentle slope where the flow is slowed by obstructions in the channel. These obstructions vary with the type of fishway. Different obstruction patterns are best applied in certain flow scenarios. One technique is pool and weir, which is similar to the lock system used to pass large ships and barges through channels such as the Panama Canal. Another type is a slot fishway, where the obstructions create a maze through the channel. A Denil fishway uses a baffle that obstructs the flow from the bottom and sides of the channel. The Alaskan steep pass fishway is similar to the Denil fishway, but the slope of the channel is greater, the baffles are configured differently along the base of the channel, and it is the only fishway that is commonly pre-constructed and placed on site. Pool and weir fishways and Denil fishways are the most common designs.



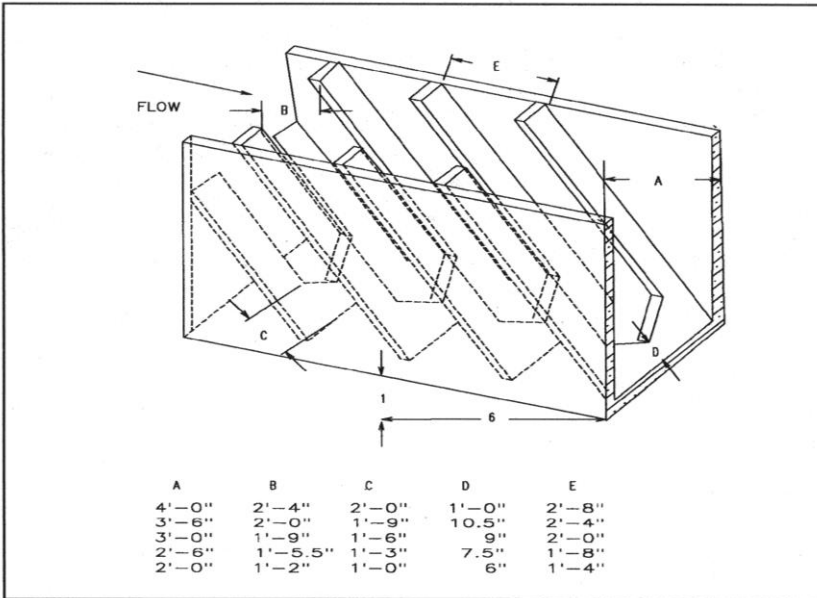

Figure 10. Denil fishway section. (Quinn 2007)

The Denil type fishway is best for variable flow patterns. Figure 15 shows the cross section and dimensions of the Denil fishway. This type of fishway is commonly designed and built on site, so it can be applied to the specific to the needs of the target species. (Quinn 2007) This type of fishway is also the most appropriate fishway for the Morey's Bridge Dam site. This design is the most effective because of the dimensions of the site (approximately 25 feet

between the dam structure and a downstream bridge), and the water depths that can be achieved from one pool to the next.

Pool and weir fishways are a common type of fishway, but would not be appropriate for the site because of the spatial constraints, and the large capacity of the pool and weir fishways is unnecessary for the seasonal flow rates characteristics of the Northeast. These types of fishways are more appropriate for the West Coast, where seasonal fluctuation in flow rates is high.

### Target Species

The target species in the Mill River are alewife, a type of river herring, who spawn in lake environments. (Bigelow and Schroeder 2002) These particular fish seek the spawning environment of Lake Sabbatia. These river herring are a swimming species, meaning that they cannot leap out of the water from pool to pool. This necessitates a design like the Denil fishway, where a deep stream of water spilling over each baffle is characteristic. Adult alewife have been observed swimming at speeds of 4.9 ft/s. (Haro, et al. 2004) This parameter requires that the velocity of the water in the fish passage channel not exceed 5 ft/s.

## 2.7 Cost Estimating

In civil engineering projects, cost estimating is one of the most important issues. It plays an important role in the decision making process between two or more project's alternatives. At the beginning of the project rough overall estimates of the project is made just for the purpose of this comparison. However, more detailed estimates involving quantities and unit costs are also needed for the completion of a feasible report. Estimates for dams and reservoirs should also include construction costs of the dam or any auxiliary structure such as temporary coffer dams, permitting costs, costs involved in clearing the reservoir areas, costs of relocation of

public highways or other properties, engineering design costs, and administrative costs for the entire project.

## 2.8 Existing Conditions

The Morey's Bridge Dam project site is being considered for rehabilitation. The poor condition of the site was the main cause of habitat destruction of the zone. According to the city's conservation agent, it was important to keep the lake at a certain level to minimize flooding of the surrounding community's septic systems, but also remain high enough to maintain the surrounding wells. The main purpose of Morey's Bridge Dam currently is to control the quantity of water flowing from Lake Sabbatia to Mill River. The spillway is in poor condition. Figure 11 shows the existing condition of these supports. The previous spillway was a gate across the area shown.



Figure 11. Current spillway condition showing gate house supports.

Contamination released when the spillway is fully open, and high seasonal variation in the Mill River water depth has caused death to many of the species inhabiting the river near the dam such as mussels, and algae. Figure 12 shows dead mussels found downstream of the current dam structure.



Figure 12. Dead mussels on the river bed.

The orientation of the spillway (directly under the gate house) was one of the reasons why it was necessary the introduction of a temporary coffer dam to the site. This approach retains the water coming from the reservoir without affecting the gate house support, which were built into the deteriorating spillway. Figure 13 shows the current coffer dam, designed by Pare Corporation, and its proximity to the gatehouse. Figure 15 shows the limited area of the site

for rehabilitation construction. There is approximately 25 feet between the current cofferdam and the gatehouse.



Figure 13. Temporary Cofferdam.

However, the temporary structure had some negative consequences, specifically the dry out of the Mill River. As a quick solution, some polyethylene pipes were added to increase the amount of flow going over the coffer dam. These pipes are shown in Figure 14. Currently, these pipes are not meeting the expectations either since they are (getting stuck) with debris from the site contamination. Morey's Bridge dam's site has been classified as a high hazard zone.



Figure 14. From beneath the bridge and gate house. PVC Pipes and gate house supports.



## **2.9 Implications of Background Information**

A wide variety of information was taken under consideration while designing the dam and fishway structures. Environmental conditions at the site are of concern to define parameters for the design in areas of structural stability. Soils information, meteorological information, site geometry, and the characteristics of the target species for the fish passage had to be researched to reach a design that catered to the specific needs of the site. As time was a limiting factor in the analysis, it was important to use background information to eliminate certain designs. For example, due to the limited area for construction on site, certain types of dams and fishways were immediately eliminated. The overflow spillway concrete gravity dam was a relatively compact design which could fit well into the existing boundaries of the site, and allow space for a fishway. The Denil fishway was selected for reasons of seasonal flow variation and a baffle design which was conducive to the swimming capabilities of the target species.

The following section explains the approach taken after certain designs were eliminated from consideration. The Hydrologic study completed on the area using produced flow values that were used to estimate the conditions that could be expected on site under Probable Maximum Flow conditions. This was applied through the hydraulic and structural analysis to design a structure that would keep the town of Taunton safe under the highest flow conditions expected on site. The Hydraulic analysis was applied through the structural design to create a structure that could withstand the forces of the flow passing through the Mill River at the site, while keeping constructability issues in mind. Cost and constructability issues were also addressed through a cost analysis and constructability plan, where the expected materials and time for construction were used to come up with a final cost for the project, and a plan was made for location of construction materials and activities was made.



### **3 Methodology**

The approach to the problem started with the hydrologic characteristics of the area. This entailed a detailed analysis of the soils characteristics, weather patterns, and topography of the watershed surrounding the site. Next, a hydraulic analysis was needed to take the flow values found through the hydrologic analysis and apply them to the geometry of the site. This involved looking into the shape and characteristics of a spillway and fish passage that would fit the needs of the geometry of the site, ensuring that major flooding could be avoided to protect the surrounding community. Lastly, the structural analysis took the information found through the hydrologic and hydraulic analysis to find a design solution where the dam and fish passage could be constructed out of a material that was appropriate for the site and followed design guidelines of the ACI and USACE.

#### **3.1 Hydrologic Analysis**

When looking at the reconstruction or replacement of structure along a water body, the design requires proper analysis of different fields of study that characterize the surrounding areas of the proposed site. In doing so, certain pieces of information were needed to be determined in an orderly fashion to progress to a final design. Once those aspects are taken into account, a justifiable design can begin to be formulated. For the Morey's Bridge Dam, it was necessary to take such steps. Figure 16 below follows the process in a condensed and organized fashion.

Hydrologic aspects of the upstream area are of great concern when performing site work along a water body. Within this analysis various techniques were implemented to ensure that the information used for the analysis had the closest characteristics to the Mill River and its surrounding watershed as possible.

To present the hydrologic analysis of the site effectively, there were certain considerations taken into account. These considerations influenced the character of the storm water flow rates used for the design of the dam. Physical characteristics of the Mill River Watershed basin were of great importance. These physical features both upstream and downstream greatly influenced the manner of certain design flow rates and velocities of the water. Another consideration was the meteorology and precipitation associated with the southeastern Massachusetts and the watershed itself. Again, this data allowed us to understand the influences of the design flow rates. In order to obtain results of these flow rates, the information gathered was then utilized in certain computer programs dealing with storm water analysis. This section provides information gathered regarding these vital considerations.

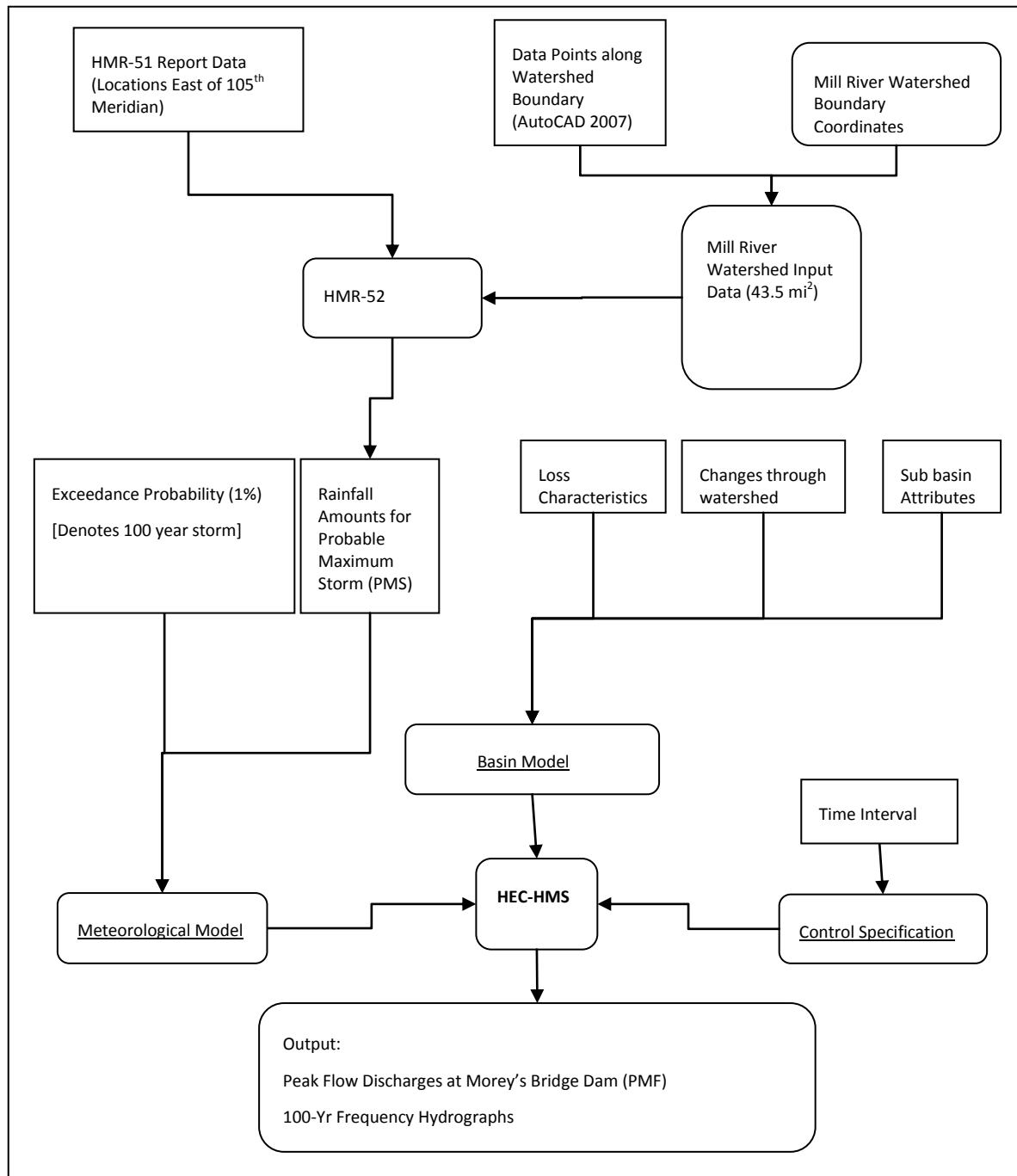

Figure 16. Hydrologic Methodology Flowchart

The main computer program used for the hydrologic analysis was HEC-HMS v. 3.1.0. The program, created by the United States Army Corps of Engineers, allowed the user to produce results that "simulate precipitation-runoff processes of dendritic watershed systems." (United States Army Corps of Engineers 2006) These results included hydrographs for different types of storm events and flow rate patterns throughout the storm. By incorporating hydrological characteristics associated with the Morey's Bridge Dam site into the HEC-HMS program, design flow rates could be determined in an effective manner.

The first flow that was needed was the Probable Maximum Flood (PMF) flow rate. Establishing this flow rate allowed structural features of the proposed dam to be designed. The main structural feature that incorporated this maximum flow rate is the outlet works of the dam. Ensuring that a proper PMF is calculated enables the design of the dam to be designed safely and effectively.

A high population exists in close proximity to the Mill River downstream of the Morey's Bridge Dam. Furthermore, historical occurrences surrounding the Mill River and the series of dams along it have shown the problems that the site could pose. Due to the situation, this is the Inflow Design Flood that was used for this site. Using the PMF as the Inflow Design Flood will also imply that average annual storm flows will be properly controlled.

The second type of flow that was needed to be determined was a maximum flow for a hydraulic analysis. This maximum flow used for this type of analysis would ensure that the structure would be able to withstand a high flow situation in terms of passing the water flow from Lake Sabbatia to the Mill River. This would include protection of the structure, its surroundings, and public safety in proximity to the site area. For analysis, this flow rate will be applied to equation's that look at discharge volumes, spillway design, and water levels at certain points through the system.

Ensuring the structure to be structurally and hydraulically sound is extremely important when redesigning, reconstructing, or analyzing a structure that establishes societal protection against naturally occurring situations. As stated, the manner in which these maximum flows were determined account for safety as much as functionality.

### *Basin Characteristics*

#### **3.1.2 Physical Characteristics**

To begin our analysis, physical characteristics were needed from the Mill River Watershed Basin. Once acquired, they were used to advance the process of determining the runoff and the precipitation characteristics. The information included the watershed outline, soil type associated with the watershed, and its land use characteristics. These watershed attributes were key factors in determining these characteristics of the watershed, which in turn could allow a PMF to be associated with the Morey's Bridge Dam site.

The outline of the watershed was the first piece of information that was determined. The total drainage area was known, however, the area relative to the profile of the drainage area was needed. This outline was needed to understand the precipitation values for the Mill River Watershed.

To understand the shape of the watershed, the first step was to acquire a map of the sub-basins within the Taunton Watershed. Multiple smaller watersheds, such as the Mill River Watershed, are located within this larger watershed. Figure 17 illustrates the location of both the Taunton Watershed Basin and the Mill River Watershed within it.



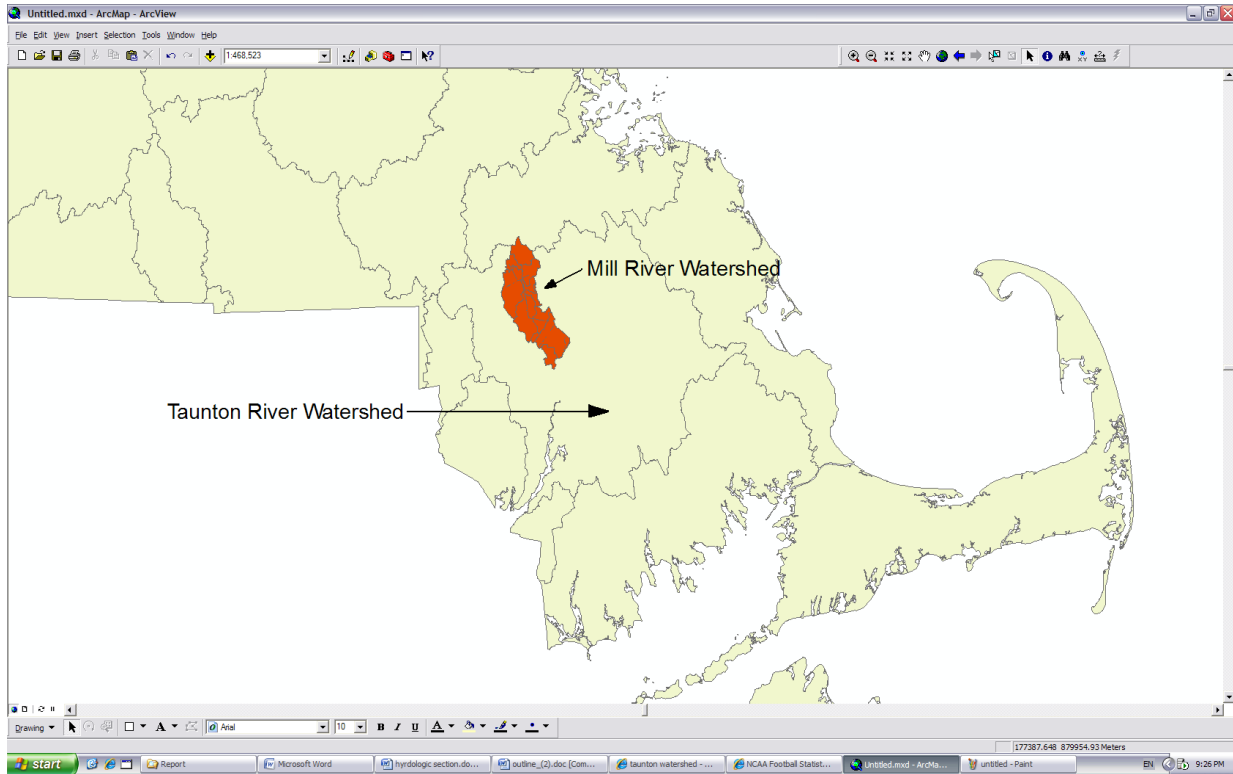

Figure 17. Location of Mill River Watershed.

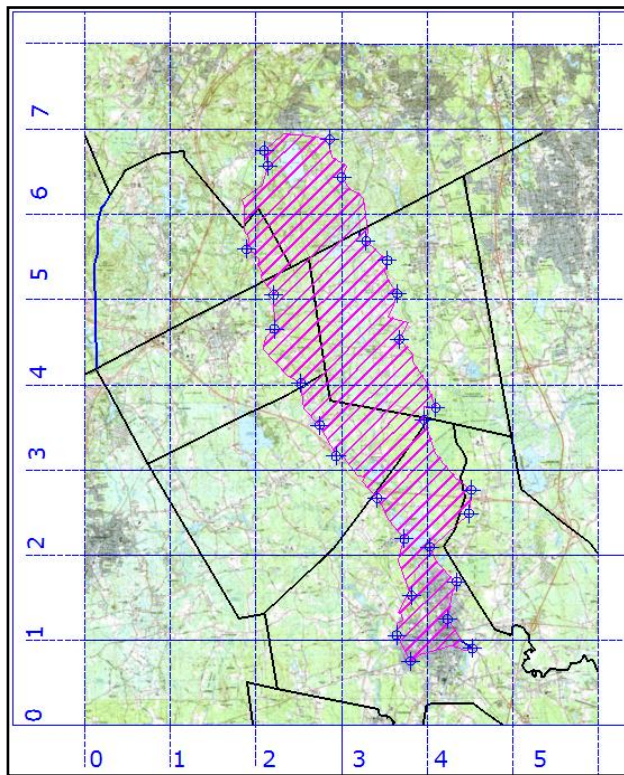

Figure 18. AutoCAD 2007 Representation of Mill River Watershed Outline.

Once the profile was found, the outline of the watershed needed arbitrary (X, Y) coordinates that were relative to the Mill River Watershed. These were needed so that a set of data points could be input into the Hydrometeorological Report No. 52 (HMR52), which will be discussed more in depth in the meteorological section. This set of coordinates allowed for the program to represent the watershed. In order to obtain these coordinates, AutoCAD 2007 was utilized to determine these coordinates along the watershed boundary.

The view of the watershed was transposed onto enough Mass GIS orthographic quadrangles so that they encompassed the entire Mill River Watershed. Upon transposing the outline to the quadrangles, the outline was traced onto the quadrangle images relative the delineation of the towns that the Mill River Watershed fell within. These quadrangles were acquired from the Mass GIS website. (Massachusetts Geographical

Information System 2007) When the outline was completed, the area of the watershed was determined in the AutoCAD 2007 program to verify that the drainage area matched up with the drainage area that the United States Geographical System (USGS) had calculated (Appendix A).

Once the watershed was delineated, the coordinates were applied to the delineation. An arbitrary origin was created at the base of the set of Mass GIS quadrangles. Points were placed along the outline. Figure 18 shows the delineation of the watershed boundary and the points associated with it. The coordinates associated with the watershed (Appendix A) were now established for input into the HMR52 computer program.

### Loss Method

Once the outline of the watershed was determined, the next step was to obtain information that allowed us to represent the flow losses associated with the watershed. There is a certain method of determining the amount of water that will be retained by the land and will not contribute to the overall flow regime. The method that was chosen to find these losses was the SCS (Soil Conservation Service) Curve Number method.

Other theoretical methods include the Initial and Constant Loss method, Soil Moisture Accounting, and the Green and Ampt method. The SCS Curve Number method is a widely accepted method when looking at a single storm event such as this analysis. This method is also able to represent a wide variety of situations, especially surrounding large areas of interest, such as basic watershed analyses. (Purdue University Research Foundation 2004)

There were certain reasons that the other methods were not utilized in determining the runoff characteristics of the watershed. For instance, when applying the Green and Ampt method, there is an important assumption made in that for a given watershed, the soil is primarily dry. This method was not used due to the upstream conditions of Lake Sabbatia and the fact that the site location was within New England, a geographical area with varied weather conditions. (Alan A. Smith Inc. 2007) Another popular runoff method that was deemed unfeasible was the Initial and Constant method. For this method, the continual loss associated with the system only ended up occurring when the system was already saturated. This would require a more specific piece of information on the watershed than was available. This piece of information was the constant rate at which the rainfall is lost throughout the watershed after the soil is totally saturated. This was unavailable due to fact that extremely accurate soil data was needed. It is for these reasons that the SCS Curve Number method was used for the runoff loss. (Texas University Research Foundation 2001)

When applying this method to the HEC-HMS program, there are three key pieces of information are needed for input in order for the program to run effectively. They include the determined Curve Number (CN), Initial Abstraction, and the Percentage of Impervious Area. For this theoretical method, it can be assumed that the initial loss coefficient is 0.1 for developed land and 0.2 for undeveloped land. (A. Osman Akan 2003) For the Mill River Watershed, a value of 0.15 was used. The reason by which this value was used is that the ratio of developed land to undeveloped land was relatively equal throughout the watershed.

The first piece of information, the CN value of the entire watershed, was needed. Due to the many different types of soil and different land uses, a certain technique to obtain a weighted

value of the entire area was used. This value is calculated by incorporating the soil type and land use throughout the entire watershed.

In order to represent the entire watershed effectively, a weighted CN value needed to be determined. The first step was to determine a CN value for each land usage. The land uses were applied as close as possible to the given land uses in Figure 19. The soil type associated with a land use was coupled with the land use to obtain a CN value for a certain land use within the watershed. The weighted CN value for the entire watershed could now be determined by applying an equation that would proportionally integrate each land use's CN value:

$$CN_{Watershed} = \frac{[CN_1(A_1) + CN_2(A_2) + \dots + CN_n(A_n)]}{A_{tot}}$$

Where:

$CN_{watershed}$  = CN value for entire watershed

$CN_1, CN_2, CN_n$  = CN values for various land uses

$A_1, A_2, A_n$  = Total areas for respective land uses

$A_{tot}$  = Total area of incorporated land uses

Chapter 9 Hydrologic Soil-Cover Complexes		Part 630 National Engineering Handbook			
<b>Table 9-5</b> Runoff curve numbers for urban areas <sup>1/</sup>					
Cover description cover type and hydrologic condition	Average percent impervious area <sup>2/</sup>	-- CN for hydrologic soil group --			
		A	B	C	D
<b>Fully developed urban areas (vegetation established)</b>					
Open space (lawns, parks, golf courses, cemeteries, etc.) <sup>3/</sup>					
Poor condition (grass cover < 50%)		68	79	86	89
Fair condition (grass cover 50% to 75%)		49	69	79	84
Good condition (grass cover > 75%)		39	61	74	80
<b>Impervious areas:</b>					
Paved parking lots, roofs, driveways, etc. (excluding right-of-way)					
		98	98	98	98
Streets and roads:					
Paved, curbs and storm sewers (excluding right-of-way)					
		98	98	98	98
Paved, open ditches (including right-of-way)					
		83	89	92	93
Gravel (including right-of-way)					
		76	85	89	91
Dirt (including right-of-way)					
		72	82	87	89
<b>Western desert urban areas:</b>					
Natural desert landscaping (pervious areas only) <sup>4/</sup>					
		63	77	85	88
Artificial desert landscaping (impervious weed barrier, desert shrub with 1- to 2-inch sand or gravel mulch and basin borders)					
		96	96	96	96
<b>Urban districts:</b>					
Commercial and business					
	85	89	92	94	95
Industrial					
	72	81	88	91	93
<b>Residential districts by average lot size:</b>					
1/8 acre or less (town houses)					
	65	77	85	90	92
1/4 acre					
	38	61	75	83	87
1/3 acre					
	30	57	72	81	86
1/2 acre					
	25	54	70	80	85
1 acre					
	20	51	68	79	84
2 acres					
	12	46	65	77	82
<b>Developing urban areas</b>					
Newly graded areas (pervious areas only, no vegetation)					
		77	86	91	94
<sup>1/</sup> Average runoff condition, and $I_p = 0.25$ .					
<sup>2/</sup> The average percent impervious area shown was used to develop the composite CNs. Other assumptions are as follows: impervious areas are directly connected to the drainage system, impervious areas have a CN of 98, and pervious areas are considered equivalent to open space in good hydrologic condition.					
<sup>3/</sup> CNs shown are equivalent to those of pasture. Composite CNs may be computed for other combinations of open space type.					
<sup>4/</sup> Composite CNs for natural desert landscaping should be computed using figures 9-2 or 9-4 based on the impervious area percentage (CN=68) and the pervious area CN. The pervious area CNs are assumed equivalent to desert shrub in poor hydrologic condition.					

Figure 19. CN Values. (National Resource Conservation Service 2004)

In order to obtain the information on the soil and land use of the Mill River Watershed, Mass GIS data layers were needed. For a reference point, layers such as sub basin areas and town boundaries were downloaded and uploaded onto ArcGIS v. 9.2. (Figure 18)

Once the watershed was located, land use and soil type data layers were transposed over the watershed and were clipped to determine the land use and soil types within the Mill River Watershed. Appendix A illustrates the land use within the watershed and Appendix A illustrates the soil types throughout the watershed.

These data layers were all found within the Mass GIS website. (Massachusetts Geographical Information System 2007) Due to the complexity of the process for analyzing data within the ArcGIS program, the attributes associated with these new layers were exported into Microsoft Excel 2007 where the data could then be examined in a workable

fashion. Percentages of land usage within the watershed were determined by calculating the amount of land area taken up by each respective land use.

The next step in the process for finding the CN value was to take the data acquired from the GIS process and transfer it to data that can be compared to similar land uses and soil types to determine CN values (Figure 19). The land uses that were found from the GIS data layers were matched as best as possible with similar land uses from Figure 19. To determine what soil type each land use was, the soils data layers were cut and joined to fit within the watershed boundary. (USDA Soil Conservation Service, 2004) . Figure 20 below shows a pie chart that related the different land uses within the Mill River Watershed as well as the actual area for each land use in acres.

Area (Acres)	Land Use
505.18	Cropland
430.23	Pasture
20504.76	Forest
685.49	Wetland
67.05	Mining
551.10	Open Land
51.56	Participation Recreation
4.82	Water Based Recreation
215.01	Residential
137.72	Residential
2306.06	Residential
3105.17	Residential
84.63	Commercial
370.19	Industrial
406.28	Urban Open
402.53	Transportation
5.83	Waste Disposal
765.27	Water
271.35	Woody Perennial

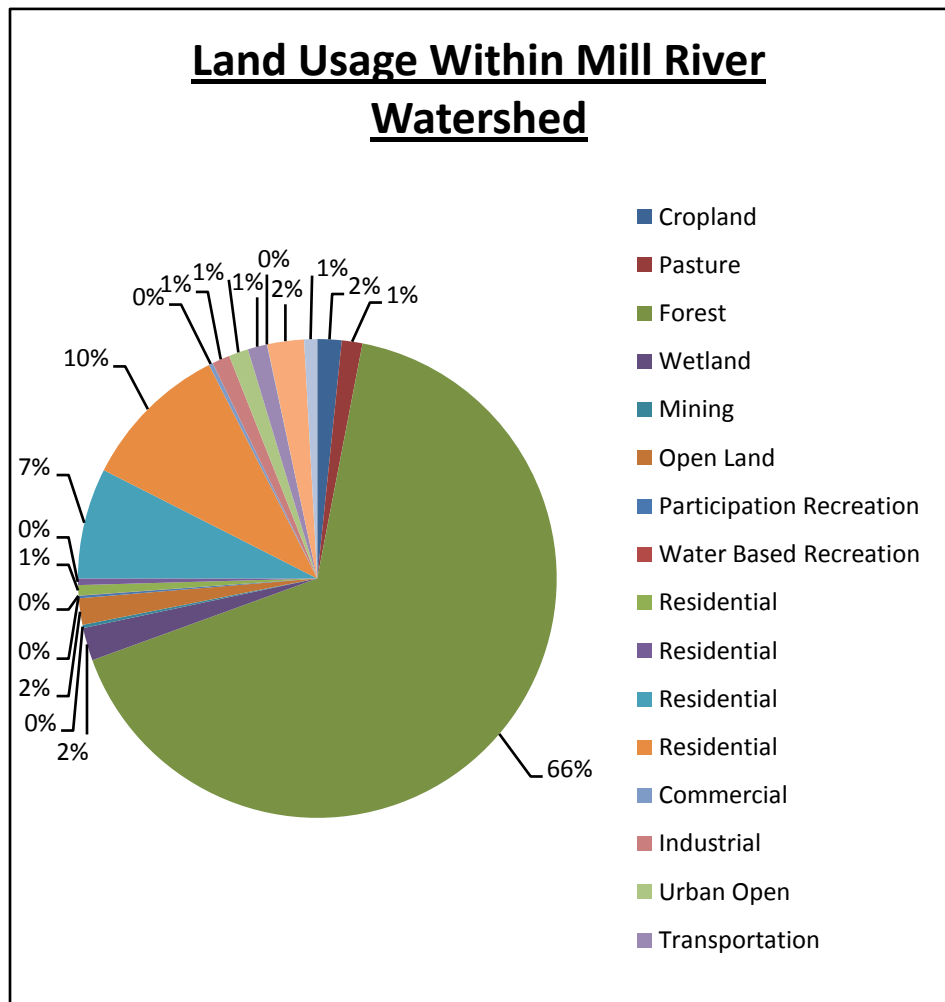

Figure 20. Division of Land Use.

Due to the nature of the watershed, some of the land uses were simplified and condensed to ensure that the CN values could be represented effectively over the watershed. All residential uses were combined into one total area and allocated as 1/3 acre lots. This was due to the fact that data on the size of residential lots throughout the

watershed could not be specifically determined. Therefore, the lot size was set at an average lot size. Another way the data was altered to determine CN values was to combine woody perennial and forest uses. Incorporating these two into the forest land allowed for the woody perennial land to be represented, rather than totally omitting it.

It was determined that the soil type to be used for the hydrologic analysis within the Mill River Watershed was all Type C soil. By using ArcGIS, there was a substantial area within the watershed where the actual soil types were in fact determined. However, the nature of this incomplete data lied in concentrated areas. Due to this, accurate data reflective of the watershed could not be obtained.

Due to this, the soil characteristics were considered on a much broader scale. In terms of the watershed overall, Lake Sabbatia lies within a sizeable section of the watershed. There are also various locations of wetland areas that lie along the forested areas. Also, the slope of the watershed is relatively small, at approximately 1%. From the basic layout of the Mill River watershed, it was deduced that the water table has the opportunity of being quite high. The Hydrologic Soil Group (HSG) is not solely based on the makeup of the soil, but also on other factors such as water table elevation and saturation rates. In understanding this idea, regardless of what exactly the soil consists of, it was applied to distinguishing between soil types. (National Resource Conservation Service 2004) The soil type that best represented the watershed as a whole was type C soil, with a CN value of 73.99. Table 6 below illustrates the difference in weighted CN values from type B soil and Type C soil. As you can see, the difference in CN value is substantial due to the range of values available. It should also be noted that the "CN Value (B)/(C)" represents the portion of the total CN value that accounts for each individual land use.

Table 6. Weighted CN Value Determination

	% AREA	CN	SOIL TYPE	CN Value(B)	CN	Soil Type	CN Value(C )
Cropland	2%	72	B	1.44	79	C	1.58
Pasture	1%	61	B	0.61	74	C	0.74
Forest	66%	60	B	39.6	73	C	48.18
Wetland	2%	58	B	1.16	85	C	1.7
Mining	0%	-	B	-	-	C	-
Open Land	2%	69	B	1.38	79	C	1.58
Participation Recreation	0%	-	B	-	-	C	-
Water Based Recreation	0%	-	B	-	-	C	-
Residential	18%	72	B	12.96	81	C	14.58
Commercial	0%	-	B	-	-	C	-
Industrial	1%	88	B	0.88	91	C	0.91
Urban Open	1%	69	B	0.69	79	C	0.79
Transportation	1%	98	B	0.98	98	C	0.98
Waste Disposal	0%	-	B	-	-	C	-
Water	2%	-	B	-	-	C	-
Woody Perennial	1%	60	B	0.6	73	C	0.73
	97%			62.16			73.99

Weighted CN value for Type B Soil

Weighted CN value for Type C Soil

Once the weighted CN value of the watershed was determined, the next piece of information needed was the initial abstraction, or the loss associated prior to runoff beginning. For our case, this outlet was the Morey’s Bridge Dam site. Once this was determined, the information needed for the “loss” tab within HEC-HMS would be complete. The initial abstraction was calculated by applying the weighted CN value of the watershed. The next equation yields the total potential abstraction of the watershed:

$$S = \frac{1000}{CN} - 10$$

By taking 20% of the value (S), (Alan A. Smith Inc. 2007) the initial abstraction was determined to be 0.703.

The last piece of information that was to establish the percent that was impervious throughout the entire watershed. This was needed for input into HEC-HMS. Again, ArcGIS was used to determine this number. Appendix A illustrates the impervious area within the Mill River Watershed. The percent impervious was estimated to be 10%.

The aspects of loss associated with the watershed that were needed for the HEC-HMS program were now available. These three pieces of information were then entered into the loss tab associated with the basin characteristics of the watershed.

### Transform Method

The next calculation was in determining the response time for the flow within the watershed to reach a given site, which in our case is the Morey's Bridge Dam site. This response time is known as the standard lag time. The standard lag time is needed to represent the flow intensity at given times in the single storm event. This lag time was determined using the SCS Lag Time Equation, expresses in the equation below.

$$T_{LAG} = L^{0.8} \frac{(S+1)^{0.7}}{1900\sqrt{Y}}$$

Where:

$T_{lag}$  = Standard Lag time (hrs).

L = Hydraulic length of watershed (ft).

S = Maximum retention in the watershed in inches as defined by:

$$S = \frac{1000}{CN} - 10$$

Y = Watershed slope (%).

CN = SCS curve number for the watershed (determined in the *Loss Method* section).

To determine the hydraulic length of the watershed, the ruler tool on ArcGIS was used. This allowed us to find a length of approximately 77,257 feet. Once this was determined, the only other unknown variable was Y. This value is the calculation of the watershed's overall slope. It was determined by taking the elevation change over a known length that appropriately exemplified the watershed. These values were then calculated to determine the slope. A slope of 0.07% was calculated. A factor of safety was included, which increased the slope variable to become 1%. This was done to ensure that the overall slope of the watershed was within the calculated percentage, as well as allowing for steep areas within the watershed to be accounted for.



By applying information obtained in the previous paragraph,  $T_{lag}$  was determined to be 12.29 hours. This value was entered into the HEC-HMS software.

### Base Flow Considerations

The Mill River Watershed model, which will be run in HEC-HMS, will not incorporate a base flow condition. There are two main reasons for this. The first reason is for simplicity to simplify the HEC-HMS program. The second reason is in the nature of the watershed. Upstream of the Morey’s Bridge Dam site, the water characteristics are more static in the sense that the flow entering Lake Sabbatia is minimal. (Shaw 1994)

### 3.1.3 Meteorological Characteristics

At this point, the physical characteristics of the Mill River Watershed had been analyzed effectively. Once the watershed’s physical characteristics were investigating, the meteorological traits then needed to be determined. It should be noted that the physical components of the watershed are not dependent on the meteorological data needed for the hydrologic analysis.

#### *Precipitation Characteristics*

Table 7. Probable Maximum Precipitation values for Southeastern MA.

PMP From HMR51					
AREA	DURATION				
(SQ. MI.)	6-HR	12-HR	24-HR	48-HR	72-HR
10	25	29	32	36	38
200	17	20.5	23.5	27	28.2
1000	12	15.5	19.5	23	23.5
5000	7.5	11	14	17.5	18.5
10000	5.8	9.1	12	15	16.1
20000	4.2	7.2	9.9	13.1	14.1

There are a few different methods by which the HEC-HMS program accounts for the precipitation characteristics of a storm event. These methods include the standards project storm method, the SCS hypothetical storm method, the user-specified hyetograph method, and the frequency storm method. The frequency storm method was chosen due to the fact that the design flow called for a 100-year PMF, and the frequency storm method includes an exceedance probability which the group could utilize. (United States Army Corps of Engineers 1994) Also, the weighted CN value was needed as

part of the input. These pieces of information from the frequency storm method better exemplifies the characteristics of the Mill River Watershed.

Along with the watershed coordinates, data from the Hydrometeorological Report No. 51 was needed to produce an input that determined the maximum precipitation amounts for a single storm event. The data from this report consisted of isopluvial maps that estimate the probable



maximum precipitation (PMP) in inches that would fall within a certain area over a certain time period. The precipitation amounts were estimated from the graphs in Appendix E. The values that were determined to be suitable for southeastern Massachusetts are listed in the Table below.

The next step was to enter certain pieces of information into the HMR52 program such that rainfall amounts from the probable maximum storm could be determined. The two key pieces of information that were input into the program were the data from the HMR51 and the coordinates of the watershed that were determined.

Another piece of information that was needed for the program to successfully run was what the storm area would be. In this case, because we were designing for “worst case scenario,” the total drainage area of the watershed (44.3 mi<sup>2</sup>) was used. Appendix A shows the data that was entered for the program to successfully run.

In order to use the program efficiently, The United States Army Corps of Engineers created a basic tutorial that explains the basic steps to run the program successfully. Appendix F presents the tutorial in depth.

The output data consisted of the precipitation amounts over a three day period for every six hours. This data can be seen in the later section of Appendix A. The data generated from this program was then inserted into the precipitation characteristics HEC-HMS. Because a three day storm with six hour intervals could not be entered into the precipitation table in HEC-HMS, the data up until a two day storm was used. This limitation was determined to not be an issue due to the fact that the dramatic increase in rainfall occurred prior to 24:00 on the second day of the storm. Therefore, total rainfall accumulation on the last day (day three) was no more than two inches, with the accumulation occurring at a steady rate. This enabled the values up through day two to be sufficient.

### *Hydrologic Engineering Center-Hydrological Modeling System (HEC-HMS)*

The analysis was performed using the *HEC-HMS v. 3.1.0*, which had been discussed in previous sections. Figure 21 illustrates the interface layout of the program.

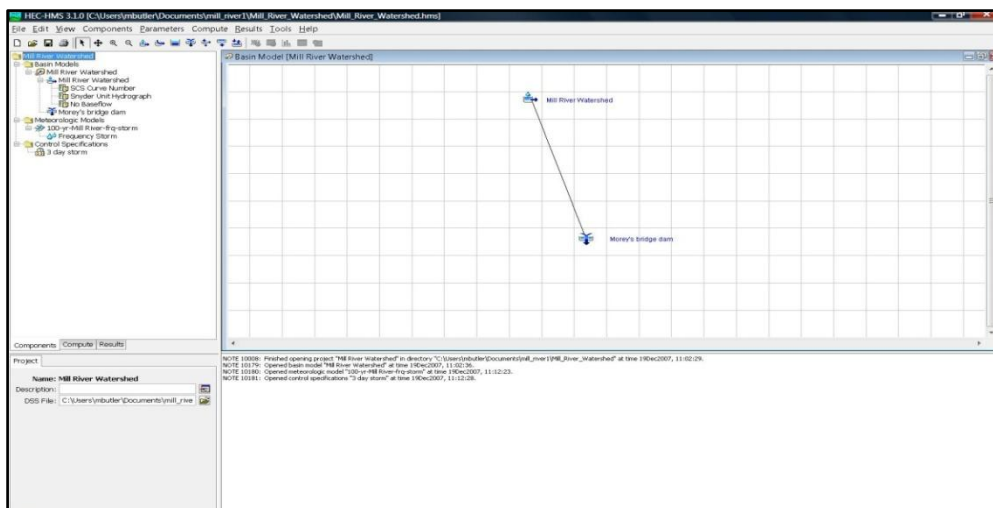

Figure 21. HEC-HMS Layout

The pieces of information determined for the program to run both successfully and sufficiently were entered. Proper data of the basin characteristics and the nature of the basins meteorology were determined for such input. Figure 22 and Figure 23 below list the input data for the basin characteristics in tab format, as it appears within the program.

Figure 22. Basin Characteristic Tabs.

Figure 23. Meteorological Characteristics Tab.

Once this critical data was input into the HEC-HMS program, the program model was run using all the characteristics previously entered. The program required a control specification for the model to run successfully. The HMR52 output data gave precipitation amounts over a 3 day period with 6 hour intervals. These parameters were used to control the Mill River watershed basin model, which were inserted into HEC-HMS under the control specification tab. The tab, along with what was inserted can be seen in Figure 24.

Figure 24. Control Specification

### 3.1.4 Fish Passage Hydrology

The hydrologic approach for the fish passage was based on recommendations from Dick Quinn, Hydraulic Engineer for the U.S. Fish & Wildlife Service (Quinn, Intro to Fishway Hydrology & Hydraulics -FERC Fish Passage Training Course 2007). The hydrologic design of the fish way differs from the design of the spillway significantly in that the flows of concern were only the flows within the migration period of the target species, alewife. The main migration month is April, but many individual fish may pass earlier or later for unknown reasons, so the migration period to be applied here was determined to be the months of April and May. This period was extended by 10 days into March and June, to allow for individual fish that may pass early or late. Data were found through the USGS website, under Massachusetts Surface Water Data (United States Geologic Survey (USGS) 2007).

It was necessary to determine maximum, minimum and average (day-to-day) flows to find a hydraulic operating range for the ladder. It was important to use as many years of stream gauging data as possible to correct flow patterns from year to year. The Wading River, located in Norton, Massachusetts, is a nearby river of similar size to the Mill River in both drainage basin area and streamflow statistics. Wading River flow data was used because data from the Mill River only went back only 6 years and the Wading River had 17 years of recorded daily flow data. These maximum and minimum flows of operations were determined through statistical analysis of the last 17 years of gauge data within the migration period. Considering the 3 day window of passage, it is important that under extreme high or low flow conditions that may occur within 15-20 years are taken into account. These extreme conditions may persist for an excess of 3 days. These flows may represent an unusually wet year (rain and snow) or an unusually dry year. If fish are not able to pass under these conditions, it could result in a dramatic reduction in the population counts for the following years.

The operating flows were established based on the Wading River data from 1990-2007. The primary flow calculations were based on the month of April only. Then, these numbers were compared to the entire period of interest, March 10 through June 20 of each year 1990-2007.

Establishing the average flow conditions, which is a flow rate that would be expected on an average day in a season of typical temperatures and precipitation, involved calculating the mean of the mean daily flows for March 20- June 10, and the highest median for April.

Establishing the maximum flows, which is a flow rate that would be expected during a rainy or snowy year, involved calculating the annual mean flow and multiplying it by 3. This was a recommendation of Mr. Quinn to get a basic maximum flow rate that was compared later on in the analysis to actual daily flow data.

The minimum design flows were determined by finding the 99% flow (99<sup>th</sup> percentile) for the latest month on record (May 2006). Similar to the maximum flow procedure, the minimum flow procedure started with establishing a low flow and then comparing it to collected daily data. (Quinn 2007)

Since the fishway must be passable for individual fish within three days of entering the passage, the daily data were checked for periods where the minimum or maximum design flows were exceeded for 3 or more days. This involved a process of elimination, where the first minimum

or maximum flow was compared to the daily data, and flows that exceeded the flow were crossed out. A period of more than 3 days was counted as an impassable flow period, and the number of these periods was counted. If the number of impassable events in the last 17 year exceeded 3, the boundary value has to be changed to reflect these flows. (Quinn 2007) In this way, the maximum and minimum flows were established, until flow values were reached such that they were not exceeded more than 3 times. Tables showing USGS data and analysis of this data can be found in Appendix A.

### **3.2 Hydraulic Analysis**

The analysis for the nature of the flows travelling over the spillway were calculated using a series of hydraulic equations found from the USACE hydraulic design manual, Hwang's *Fundamentals of Engineering Hydraulics*, and Sturm's *Open Channel Hydraulics*. Flow data used to estimate high, low, and average design flows stems from the Hydrologic Analysis. The approach for estimating these flows involved statistical analysis of gage station data. Estimation of the probable maximum flood incorporated the USACE HMR51 and HMR52 programs. Figure 25 shows the steps that were taken to analyze the section hydraulically, after the design flows were determined through the Wading River historical data and hydrologic analysis. First, hydrologic data was collected from the Wading River and compared to current hydrologic data from the Mill River. Next, Google Earth was used to obtain measurements of the Mill River's length and width characteristics through the tail water channel and the site location.

The flow data from the hydrologic analysis and the dimension data from Google Earth were used to start the analysis. This data was analyzed through a series of hydraulic equations. These equations are explained in Table 8. These equations (Manning's Equation, Froude Number, and critical depth) were applied and compared to identify the flow profile of the channel. These equations were applied to all sections of the channel between the spillway and the next dam downstream.

The spillway dimensions were found next to analyze the nature of the flow down the spillway. This was based primarily on the reservoir level that had to be maintained, and the flow volume that was expected during high, low, and average flow conditions. The Spillway Equation was applied here, as well as Manning's Equation, Froude number, and critical depth.

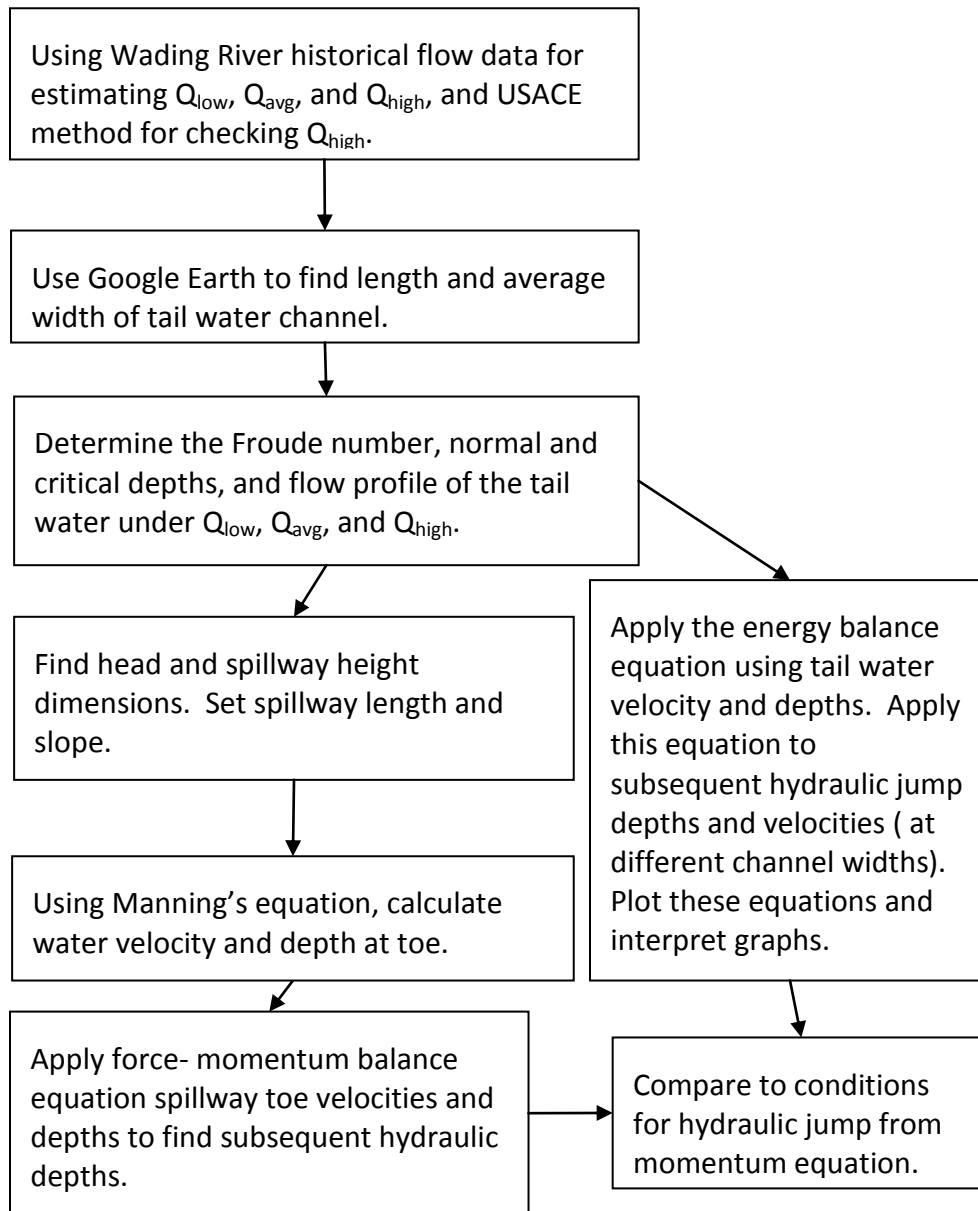

Figure 25. Hydraulic Analysis Flowchart.

To locate expected changes in the flow profile between the toe of the spillway and the bridge channel, a momentum balance was applied and the results were used to generate a graph for the possible flow conditions as the flow entered the bridge channel (constriction). This plot was compared to another plot of the flow conditions as the flow exited the bridge channel (expansion). This plot was generated using tail water flow values. These plots were compared to predict flow conditions through the bridge channel.

The first step in the hydraulic analysis was to segment the channel of water between Morey's Bridge dam and the next dam on the river into sections for analysis. This was necessary to apply the correct hydraulic equations to each section to predict the flow profiles at each section. Next hydraulic design equations were applied.

### 3.2.1 Spillway Hydraulics

The tail water channel dimensions were measured using Google Earth. The length and the width were used to model channel dimensions. The channel, though somewhat winding, was modeled as a straight channel for simplification purposes. Next, Manning's equation was applied, Froude numbers were found, and critical depths were identified in the tail water channel. Equations used to calculate water depths, velocities, etc. are explained in Table 7.

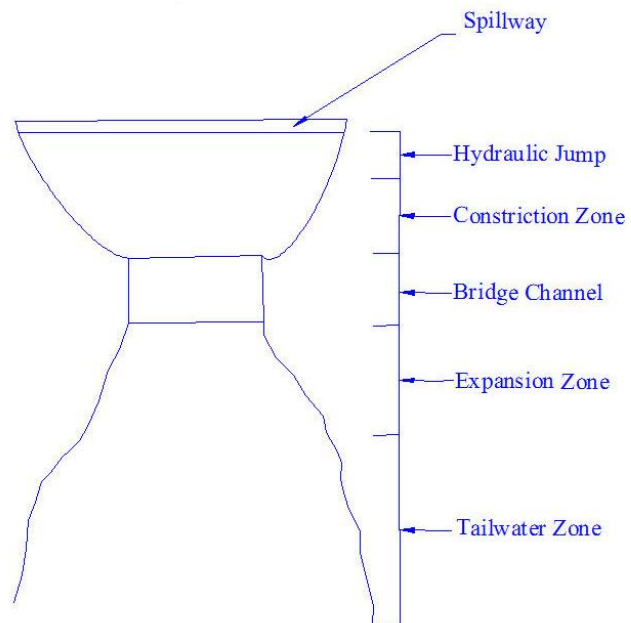

Figure 26. Hydraulic cross sections, plan view.

Dimensions closer to the site were estimated based on plan drawings for the temporary cofferdam that was built on the site. The dimensions shown on the plans included some elevations of the bridge and current cofferdam structure, the widths of the channel on the head and tail water sided of the bridge, and the distance between the coffer dam and the bridge.

Next, the spillway velocities and depths were found. The spillway calculations were based on the shape of the spillway structure. This particular spillway was modeled as a sharp crested weir, or an ogee spillway. This means that the nappe of the tail water travelling over the crest of the spillway has a similar shape to free discharge over a sharp crested weir. This is illustrated by Figure 27. A calculation to estimate the flows over this type of spillway was found in Fundamentals of Hydraulic Engineering. (Hwang 1989)

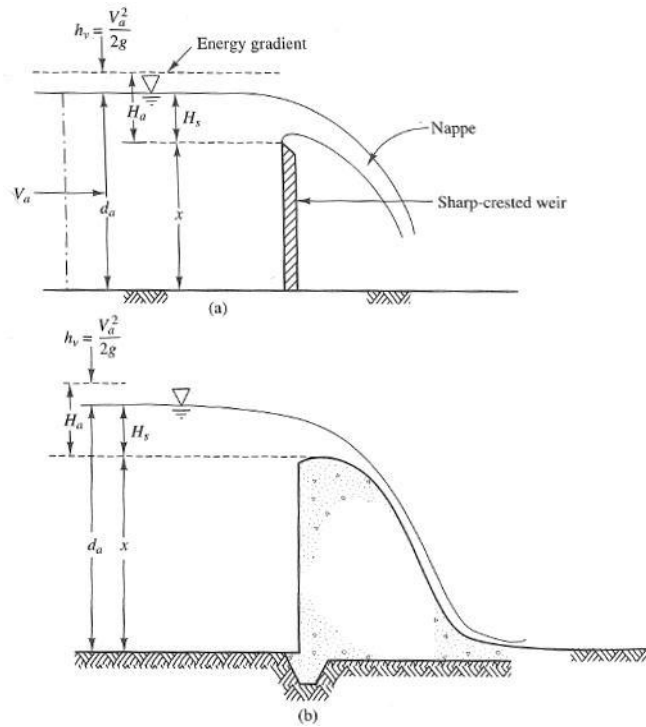

Figure 27. Sharp crested Weir (a) and Ogee Spillway (b). (Hwang, Fundamentals of Hydraulic Engineering Systems 1989)

After velocities and depths were established at the toe of the spillway and in the tail water section, the hydraulic jump section, and constriction/ expansion sections were analyzed. First, it was assumed that the hydraulic jump occurred near the toe of the spillway, or between the spillway and the bridge. The initial and subsequent depths of the jump were found through application of a force-momentum balance applied to the water depths and velocities calculated at the toe of the spillway. Next, the subsequent depths were used in an energy balance to determine possible flow conditions in the channel passing under the bridge. This channel occurs after the constriction. The possible depths and velocities here were plotted and compared to the possible depths and velocities of the tail water section, also plotted using the energy balance. Comparing these two plots

established where the hydraulic jump can be expected to occur, and what depths and velocities can be expected in the channel passing under the bridge.

Table 8. Hydraulic Equations used in Analysis

EQUATION:	PURPOSE:	APPLIED TO:	SOURCE:
Manning's equation $Q = \frac{1.49}{n} R^{2/3} S_0^{1/2}$	Relates normal depth, flow rate, cross sectional area, and channel slope.	Spillway Tail water	(Hwang 1989)
Critical depth $y_c = \sqrt[3]{\frac{q^2}{g}}$	Finds the depth where transition from sub to supercritical flow occurs.	All analyzed sections.	(Hwang 1989)
Froude number $F_r = \frac{V}{\sqrt{gy}}$	Ratio between forces of velocity and gravity. Determines whether flow is sub or supercritical.	All analyzed sections.	(Hwang 1989)
Force/ Momentum Balance $d_2 = \frac{1}{2} d_1 \sqrt{1 + 8F_r^2} - 1$	Given initial depths, finds subsequent depths through hydraulic jumps.	Spillway toe, entering constricted flow energy balance.	(Hwang 1989)
Spillway Equation $Q = C_d L H_a$ $C_d = 3.22 + 0.40 \left[ \frac{H}{P} \right]$	Relates spillway height, shape, head, frictional losses, and velocities to find head at spillway crest.	Spillway crest.	(Hwang 1989)
Energy Equation $V_2 = \sqrt{\frac{2g \left[ \frac{V_1^2}{2g} + y_1 - y_2 + z_1 - z_2 \right] + C V_1^2}{(1 + C)}}$	Sum of energy in potential and kinetic form. Also takes head loss into consideration. Used to plot & compared bridge channel conditions.	Constriction/ expansion section.	(Foronda 2004)
Fishway Discharge Rating Equation $Q = C_d h_u^{1.75} b^{0.75} \sqrt{g s_0}$	Relates flow rate, passage slope, baffle opening, and head losses due to baffles throughout fishway channel to establish depth at first baffle.	Fish passage channel.	(Odeh 2003)

### 3.2.2 Fish Passage Hydraulics

Hydraulic analysis in the fish passage section was similar to the hydraulic analysis of the spillway. However, the passage was analyzed at the target design flows, which were different



than those specified for the spillway. This was because the fishway was designed for optimal operation under migration period flows. The process for calculating design flow rates and depths for the fishway was based on the design that the fishway channel would essentially be incorporated into the spillway, but separated by a wall.

Important areas of concern for the fish passage were the entrance conditions, water velocity and depths through the passage channel, and exit conditions.



Figure 28. Example Fishway. (Maryland Department of Natural Resources 2007)

Under the flows that could be expected during the migration period the velocities in the passage channel were checked to make sure that the conditions were passable for the target species. To check the depth of water traveling through the passage, dimensions and flow rates were calculated using the flow discharge equation developed by Mufeed Odeh in the *Journal of Hydraulic Engineering* (Odeh 2003). Incorporating the fish passage into the spillway by setting it in and separating the fish passage channel from the spillway

channel by a tall wall, Odeh's flow rate calculation was used to find the depths of water passing through the channel. As flow rates and water depths at the crest of

the spillway can fluctuate, a graphical approach was used to approximate the water depths at different flow rates. This approach was based on comparing velocities and depths possible for a given flow rate to Froude numbers that were expected at the exit channel. Appendix C shows these plots of depths versus velocities for different flow rates, compared to Froude numbers of 0.9 and 0.1. Since it was assumed that flows at the crest of the spillway (immediately before the flow starts to accelerate down the spillway) is in a subcritical state, depth and velocities near the intersection of the 0.9 Froude number plot were used in the analysis. Since the baffles are incorporated into the fishway channel to decrease the velocity of the flow, the depths through the fishway can be expected to increase as the flow approaches the entrance channel. This equation is shown in Table 8.

The entrance jets were of concern because the velocity of the water exiting the fish passage had to be greater than the velocity of the water discharge over the spillway. A target value for this jet was set at greater than 5 fps. This high velocity jet is what attracts fish to pass through the fish way channel, instead of continuing towards the dam. The flow conditions throughout the passage were important because the target species (alewife) is a swimming species, not a jumping species. Therefore, the depth of the water passing over each of the baffles had to be deep enough for the fish to swim. The exit channel is upstream of the spillway structure. These conditions had to be analyzed to find the flow conditions in the fish way channel.

Figure 28 is an example of what the Morey's Bridge Dam Fishway may look like. The entrance channel is labeled in the figure. This is the area where the flow velocity must be high enough to attract alewife towards the passage channel.

The flow velocity travelling across the first baffle (near the exit channel) will be the highest velocity through the entire passage. This velocity was checked and compared to velocities that alewife were capable of swimming through. If this velocity was too high for alewife to pass, none would be able to pass through the fishway. The target velocities for the passage were between 3-5 feet per second (Maine Department of Transportation 2004).

### 3.3 Structural Analysis

The structural design of the concrete gravity dam and the incorporation of the fish ladder were based on the hydrologic and hydraulic analyses that were performed in previous sections. With the determination of design flows and flow characteristics the height of the dam was stated and then the structural analysis was performed. As stated in the background section, once the required height of the dam was set, the dam type could be selected.

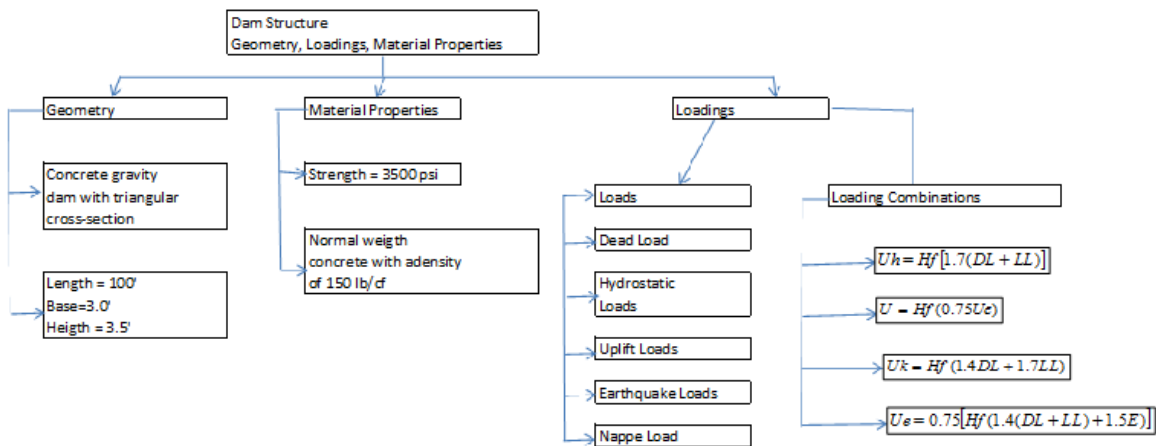

Figure 29. Structural Analysis Flowchart A.

Since gravity concrete dams require a site where there is hard rock at or near the surface, the depth of soft material above the rock should not exceed 20 ft, the rock should be able to support 8 to 10 tons per square foot, and they are well suited where the length of the crest of the dam is at least five times its maximum height, this type of dams is was a good choice for Morey's Bridge Dam's restoration project. A concrete gravity dam was chosen over a roller compacted concrete dam or an embankment dam mainly because of the characteristics of the spillway, the future incorporation of a fish passage to the site, and the space needed for construction process. The spillway used in this project was an overflow spillway, which produces nappe forces that act against the structure, affecting its stability. The weight of the water flowing over the crest of the dam and the nappe forces are not resisted by embankment dams as well as by concrete gravity dams. The functions and strengths of roller compacted concrete gravity dams are similar to those of concrete gravity dams. However, concrete gravity dams can be precast or cast in place while roller compacted concrete dams can be only constructed in the site. This option offers a benefit through the cost of construction. Roller compacted concrete dam's construction might be faster than the concrete gravity dam's

construction, but it is usually used in big sites since the amount of equipment and transportation used for the construction of roller compacted concrete dam would not fit comfortably in a small site like the one under consideration. Although precast materials often can be less expensive, cast in place is usually used when the structures are relatively small. One of the main advantages of precast materials, such as beams is that it accelerates the construction process of a project. If the project involves a multistory building this would be a good consideration, but since the concrete dam designed in this project was a very small structure that requires a relatively short construction period, the cost difference between cast in place and precast process is not relevant. These reasons made the gravity concrete dam the most feasible solution for the design.

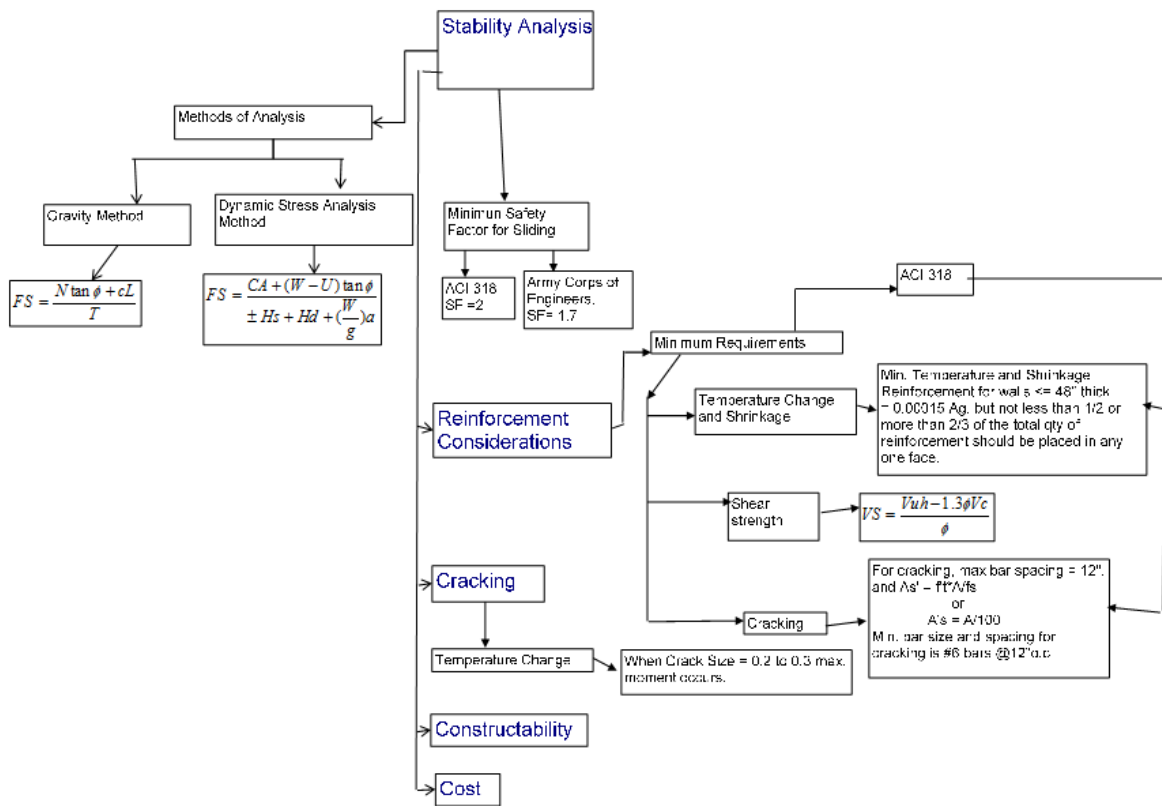

Figure 30. Structural Analysis Flowchart B.

The structural design for the structure of the dam was made assuming that there was not a fish ladder included. According to the hydraulic analysis results for the spillway design, the downstream face of the dam needed to be sloped at 0.85 %, which is still under the maximum base/ height ratio limit of 1.0, stated by the Army Corp of Engineers. Taking into consideration the site elevations provided by the Cofferdam plan drawings shown in Figure 15 on page 18, the height of the structure had to be at least 3.5 ft to maintain an adequate depth for well recharge, while minimizing the chance of flooding septic systems surrounding the lake. The length of the dam for the design is considered to be 100 ft; this value is taken from the site plan and taking the existing temporary coffer dam as a second reference. All these dimensions are

involved in the geometry of the dam. The other important consideration in the design was the properties of the material, in this case concrete. For this design, it was assumed normal weight concrete with a density of 150 lb/cfs and strength of 3500 psi would be used to construct the dam.

The overall design of the dam was based on the purpose of the structure, site characteristics, and a detailed hydrologic analysis. The purpose of Morey's Bridge Dam is to control the water flow from the reservoir to the river. However, it also acts as a barrier in case of a flood in the area. The site and soil characteristics (abbreviated form can be found in the background section) were the source of an overall view of the site and its surrounding areas. Through the data collection phase, the site plan of the existing conditions at the site was obtained, which included a topographic survey made by PARE Corporation. The following figure is a reproduction of this plan at a smaller scale (a bigger scale plan is included in the background section of the report).

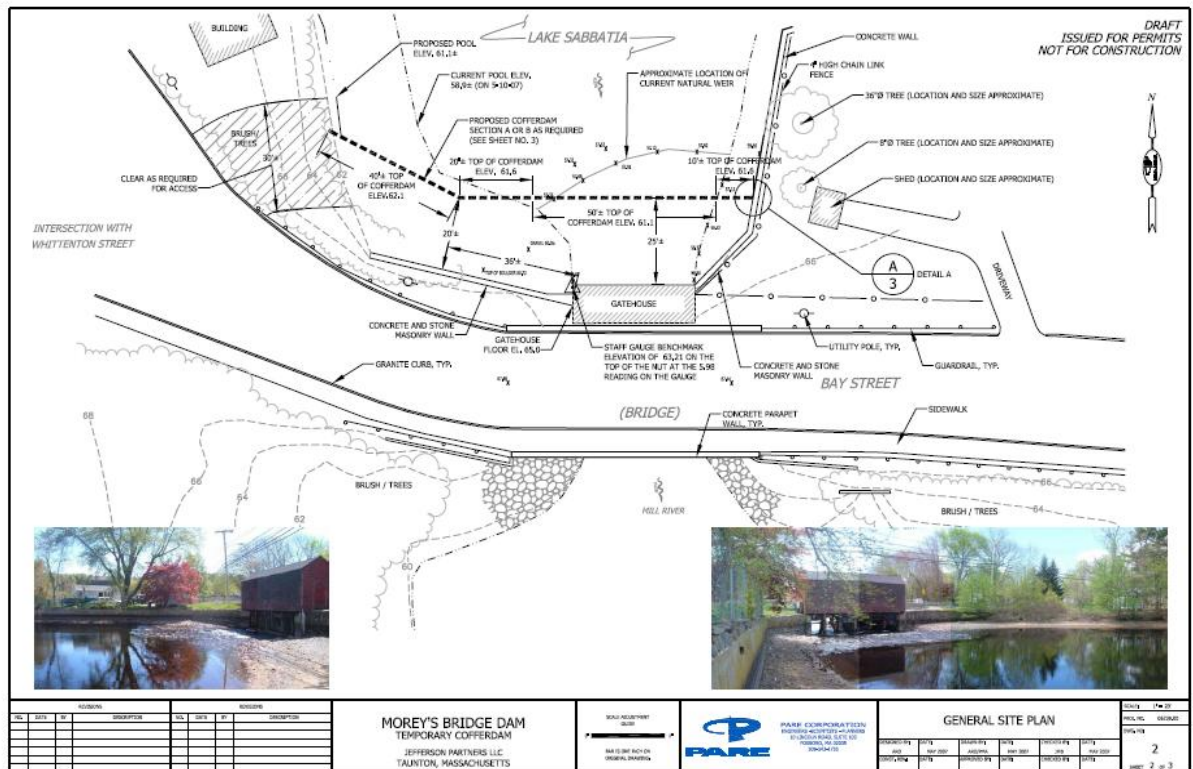

Figure 31. Cofferd Dam plan view. (Pare Corporation 2007)

This plan provided the spot elevations of the site. Some of the elevations used for the design were the pool elevation, the top of the temporary coffer dam elevation, and the existing elevation of the gravel section located between the temporary structure and the gatehouse. According to Dick Quinn the actual pool elevation, which is 58.9 feet, is 3.4 feet below the normal pool elevation. However, the actual pool elevation was considered for the design. The top of the coffer dam elevation was approximately 61.6 feet, while the elevation of the gravel section was about 60 feet. The difference between the current pool and the gravel section was about 1 foot and the height of the coffer dam was about 3 feet. These values served as a guide



Table 9. Summary of Structural Equations.

Load Description	Equation
Dead Load	Equation 1 $DL = \frac{BH}{2} * 150lb/cf$
Hydro Static Load	Equation 2 $HsLoad = \gamma_w * H$
Uplift Load	Equation 3 $U1 = \gamma_w * H1$ $U2 = \gamma_w * H2$ $U3 = (1 - e)(U1 - U4) * \frac{L2}{L1 + L2} + U4$
Nappe Load	Equation 4 $F = \rho \Delta Q \Delta V$
Earthquake	Equation 5 $E = \frac{ae}{g} \gamma_c * B * \frac{H}{2}$

After all these forces were calculated, the stability analysis of the structure could be started.

For the stability analysis, the gravity Analysis Method using basic loadings was used, for which the minimum sliding safety factor (SF) was considered to be 2.0. The Army Corps of Engineers uses a sliding safety factor of 1.6 but ACI code suggests a value of 2.0 or greater. For the purposes of this project, it was decided to be more conservative and use a safety factor of 2.0 or greater.

#### Gravity Method Analysis using Basic Loadings

The gravity method analysis using basic loadings was based on all the loadings calculated before. The sum of all moments divided by the sum of all vertical forces would yield the resultant location of the force at the base of the dam. In Table 4-1 of EM 1110-2-2200 from Army Corps of Engineers there are stability and stress criteria for the analysis. In this case, there was an unusual loading condition, where the resultant location at the base is “middle ½”, which means that the resultant must remain within the middle half of the base for overturning stability. The sliding factor of safety related to failure is the ratio between the shear strength and the applied shear stress along the failure planes of the specimen; this is the same as the following equation from EM1110-2-2200 from Army Corp of Engineers.

Equation 6. Sliding Factor related to failure

$$FS = \frac{N \tan \phi + cL}{T}$$

The Equation 7 was used for stability factor of safety was:

Equation 7. Sliding factor equation based on vertical and horizontal loads

$$FS = \frac{\Sigma Fy * \tan(\phi + \alpha)}{\Sigma Fx}$$

Where  $\alpha = 0$ , and  $\phi = 45^\circ$

And the thirdly, Equation 8 was used to check the sliding safety factor:

Equation 8. Sliding factor equation based on hydrostatic and hydrodynamic loads

$$FS = \frac{CA + (W - UI \tan \Phi)}{\pm Hs + Hd + \left(\frac{W}{g}\right)a}$$

If the sliding factor of safety is 2.0 or greater, the dam is stable; if not, other considerations such as changing the dimensions of the dam have to be taken.

Figure 29 and Figure 30 illustrate the approach involved in applying the hydrologic and hydraulic considerations to the structural analysis and design.

### Unfactored Loading

According to the Army Corps of Engineers, the stability analysis of hydraulic structures must be performed using unfactored loads in accordance with EM 2101 Stability Analysis of Hydraulic Structures. With these unfactored loads, the unfactored moments and shears could be found at the most critical sections of the structure. These unfactored loads are then multiplied by load factors and hydraulic factors to determine the required nominal strength of the section. The required minimum design strength shall resist the dead loads and live loads acting on the structure. In this case they were the weight of the structure and the nappe forces respectively. The hydraulic factor was used for the determination of the required design strength for all axial load combinations and shears and moments combination. The difference between the hydraulic factored ultimate shear force and the shear strength provided by the concrete would give the excess shear, for which the shear reinforcement should be designed.

The design shear for reinforcement is  $V_s$ , which is given by the following equation:

Equation 9

$$V_s \geq \frac{V_{uh} - 1.3\Phi V_c}{\Phi}$$



For the loading combinations we combined dead load and live load using the single load factor of 1.7 for both, as shown below

Equation 10

$$U_h = H_f [ 1.7(DL + LL) ]$$

Here  $H_f$  is the hydraulic factor considered to be 1.3 and  $U_h$  is the factored load for the hydraulic structure.

For hydraulic structure where earthquake loads are present, this equation becomes

Equation 11

$$U = H_f(0.75U_e)$$

The other loading combination equation is using more than one load factor, in this case we use a load factor of 1.4 for dead load and a load factor of 1.7 for live load. The Hydraulic factor is also included in this equation.

Equation 12

$$U_k = H_f(1.4DL + 1.7LL)$$

The fourth loading equation is considered for operational basis earthquake, and is:

Equation 13

$$U_e = 0.75[H_f(1.4(DL + LL) + 1.5E)]$$

### 3.3.1 Reinforcement Design for the Structure

The design for reinforcement was based on ACI 318 code for building structures, and ACI 350 code for environmental engineering structures. However, the specifications of ACI 350 include the ACI 318 reinforcement specifications. This is the reason why there is reference to both sections of the ACI manuals.

ASTM Grade 60 Reinforcement for the structure was assumed, which has yield strength of 60 ksi. Considering temperature changes and shrinkage, the minimum reinforcement for walls 48 " thick or less is  $0.00015A_g$ , but not less than  $\frac{1}{2}$  or more than  $\frac{2}{3}$  of the total quantity of reinforcement should be placed in any one face.

For cracking, the required area of steel is  $f'_t * A / f_s$ . When considering reinforcement for cracking the minimum bar size and spacing is #6 at 12" on center. To design reinforcement for maximum tension, the recommendations by Army Corps of Engineers, EM 1110-2-2104, Aug 2003 were followed. These are: "for singly reinforced flexural members and for members subject to combined flexure and compressive axial load when the axial load strength is  $\Phi P_n$  is less than the smaller of  $0.1 * f'_c * A_g$  or  $\Phi P_b$ ". The ratio of tension reinforcement should meet the following requirements:

Recommended Limit = 0.25  $\rho_b$

Maximum permitted upper limit not requiring special study or investigation = 0.375  $\rho_b$



Maximum permitted upper limit when excessive deflections are not predicted when using the method specified in ACI 318 is 0.50 pb

For the reinforcement design, we used ultimate moment at the structure and Equation 14.

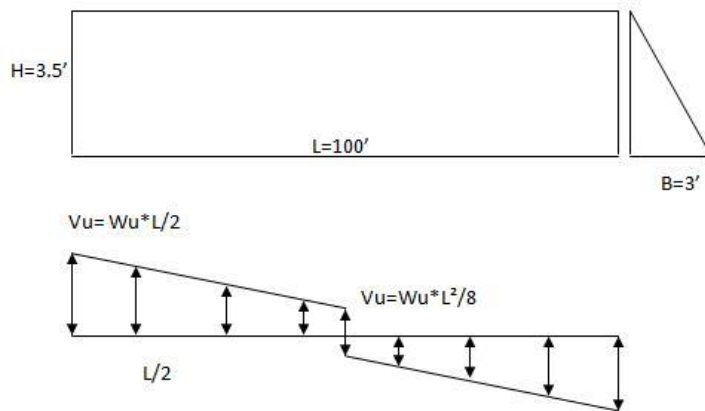

Figure 33. Shear diagram.

Figure 33 represents the shear distribution throughout the beam.

This shear diagram for the beam is using unfactored load combinations, and it shows the maximum shear at the two ends of the span and at midspan, which is very low.

The ultimate moment is found by the following equation:

Equation 14

$$Mu = \frac{Wu * l * l}{8}$$

With this value, the total area of steel needed for the structure could be found using Equation 15. However, the reinforcement of a concrete gravity dam is divided into horizontal and vertical reinforcement and its design is considering the structure as a wall. The minimum vertical and horizontal reinforcement ratios can be written in terms of the maximum spacing between the reinforcement bars. According to ACI code sections 14.3.2 and 14.3.3 the maximum horizontal and vertical reinforcement spacing is  $s(h) = Av / (0.0012t)$  for horizontal reinforcement and  $s(v) = Ah / (0.0020Q)$  for vertical reinforcement.

The required minimum areas are 0.0012 Ag and 0.0020 Ag for vertical and horizontal reinforcement respectively. The reinforcement bars can be chosen from Table 10.

Equation 15

$$As = \frac{Mu}{\phi * fy * jd}, \text{ where } \phi = 0.9, fy = 60ksi, jd = 2.8$$

This area of steel is used to find the size and number of the steel bars to be used in the structure. For this step, Table 9 was used.

Table 10. Areas, Weights, and Dimensions of Reinforcing Bars

Bar size designation No	Grades	Weight (lb/ft)	Diameter(in)	Cross-sectional Area (in <sup>2</sup> )
3	40,60	0.376	0.375	0.11
8	60,75	2.67	1.000	0.79
9	60,75	3.40	1.128	1.00
10	60,75	4.30	1.270	1.27
11	60,75	5.31	1.410	1.56

### Cracking Considerations

Crack length and width was also checked for the stability analysis, part of these calculations were done in the gravity method analysis. It was important to know that when the crack size is 0.2\* Height of the structure, the maximum moment can occurs and the structure could suffer an overturning moment, which would also affect the stability of the structure.

### 3.3.2 Fish Ladder Analysis

The steps for the stability analysis of the fish ladder were the same as the one used for the dam; the only difference were the loads acting on the fish ladder. In this analysis, the fish ladder was considered to be a concrete channel with a length of 12 ft and a height (exterior walls) of 5 ft. according to the hydraulic design, the height of the pool had to be 2 ft. One end of the structure will be located at the top of the dam and it will expand 12 ft at a slope of 6 to 1. However, this structure was analyzed individually from the dam.

$W$ (m)	$b$ (m)	$c$ (m)	$c'$ (m)	Baffle spacing ( $S$ ) (m)
1.22	0.71	0.61	0.30	0.76 <sub>a</sub>
1.07	0.61	0.53	0.27	0.71
0.91	0.53	0.46	0.23	0.61
0.76	0.44	0.38	0.19	0.56
0.61	0.36	0.30	0.15	0.41
0.46	0.35	0.30	0.15	0.30

Note:  $W$ ,  $b=7/12 W$ ;  $c=1/2 W$ ;  $c'=1/4 W$ ; and baffle spacing  $S=2/3 W$  are shown in Fig. 16-b. Values herein were based on baffle design recommended by committee on fish passes (19420).

Figure 34. Denil Fishway Dimension and Horizontal Baffle (Spacing for Various Fishway Widths). (ASCE 2003)

The fish ladder structure was designed independently from the dam's structure. The fish ladder was not found on the base of the channel, it spans from the dam, much like a ramp. This would influence the cost of the structure since there is less concrete used for the walls without affecting the safety of the structure. An example of a similar structure is shown in Figure 35.

The concrete channel has wooden slats, which are supported by steel plates connected to the walls of the channel.

These wood slats were not designed in this project. However, the force transferred from them

to the plates and then to the concrete walls should be considered in further analysis of the structure. The connections should be also considered in this design.

For the reinforcement design, we separated the channel in three sections, the two exterior walls and the bottom of the channel, and then found the area of steel needed for each section. The figure below shows the basic characteristics of our channel. The process is the same used for the dam.

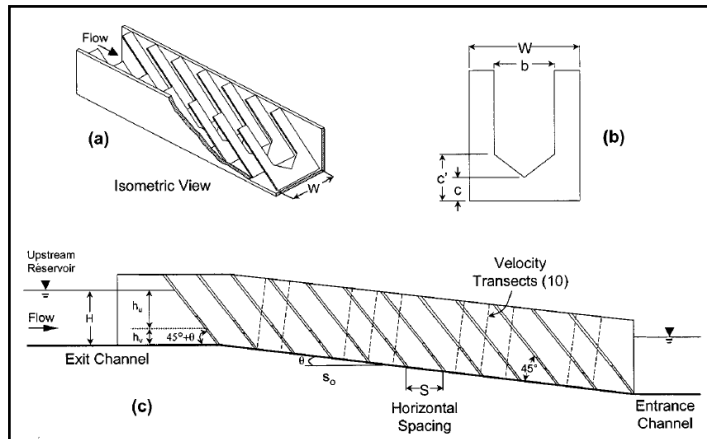

Figure 36. Basic Denil fishway design elements. (Odeh, Discharge Rating Equation and Hydraulic Characteristics of Standard Denil Fishways 2003)



Figure 35. Example Fishway. (Maryland Department of Natural Resources 2007)

### 3.4 Cost Analysis

The cost analysis for this project involved general requirements costs, site construction costs, concrete costs and reinforcement costs. The general requirements costs included the overhead and profit, which according to the RS Means 2007 manual for heavy construction is 25 percent of the total quantity costs. Scheduling cost is about 1 percent of these costs while cost control represents 0.08 percent of this total; these values are also from the RS Means 2007 manual for heavy construction. All the costs used in our cost estimate were obtained from this manual. However, the final cost of each element included in our cost estimate depended on the number of units, such as days, hours, weeks, linear foot, and cubic yards, for each of them. The number of units was estimated according to the type and size of construction. Some elements such as temporary fencing and signs number of units were estimated according to the size of the site. The structural elements such as concrete and steel's costs were based on the final structure's design and requirements. The cost of each element included in the analysis was found by multiplying the cost per unit of the specific element by the number of units of the same element.

After all the numbers of units or quantities were established, an excel spreadsheet including all these elements, their costs per unit and the number of units, was created. This spreadsheet facilitated the calculation of the total cost of the project including the general requirement costs of the project.

The cost analysis included two structures, the dam and the fish ladder. The analysis was used to show the price difference of constructing only one of the elements at a time.

### **3.5 Summary of Methods**

The methodology presented the approach of the project. It was important that the hydrologic analysis be completed first because the hydraulic and structural components of the project depended on the high flow values estimated under the Probable Maximum Flood (PMF) calculations.

The Hydrologic approach to estimate the PMF was based on the methods of the USACE and the HMR-51 and HMR-52 reports. The approach for the fish passage hydrology was primarily based on the presentations of Dick Quinn, however the hydraulic approach for the channel incorporated these presentations with studies focused on the swimming abilities of adult alewife. The hydrologic estimates for the required flowrates in the fishway channel were based on statistical analysis of seasonal and annual flow data collected through the USGS gauging stations. The spillway hydraulic approach was focused on the application of a series of related hydraulic equations. These equations were found in hydraulic textbooks and applied to low and high flows estimated through the USGS gage station data. The PMF flow was analyzed with the hydraulic equations to find water velocity, and depth information critical for structural analysis and design. The structural method was based on design codes, ACI codes design codes for environmental engineering and structures (ACI 350) and the USACE design standards for gravity dams. This analysis incorporated the results of the hydraulic analysis and the spatial limits of the site. A cost estimate was completed to compare the costs of building both the fish passage and dam at the same time, or building one before the other. The next chapter presents the calculations and results of the project.

## 4 Results & Analysis

Following the approach presented in the Methodology chapter, the preliminary results of the analysis are presented in this chapter. An overflow spillway was designed for the site based on a combination of background information collected on the site and analysis through the methodology of the design approach. Locating the dam was the first and most important step in the design. It was critical that the dam be in a location that had the potential to allow room for both the fishway channel and for the PMF flows that were calculated through the hydrologic analysis. The PMF flow data used to calculate safety factors for the dam was the priority design information. Flows estimated for the fishway analysis were important to the design, but secondary to the overall design where public safety was the most important aspect.

The results presented in this chapter include hydrologic analysis, hydraulic analysis, and structural analysis. A plan view and elevations are presented in section 4.5 and shown in Figure 54. The resulting dam was sited at the maximum distance from the gatehouse that was allowed by the existing coffer dam, approximately 25 feet from the bridge. Although this location may constrict to construction activities, it offered the best area for overflow volumes over the spillway, and adequate room to site the fishway channel on the east side of the dam.

The fishway channel was designed to be set 1.5 feet into the dam, allowing adequate depths of water to travel over the first baffle in the spillway, even under low flow conditions. The fishway, in turn, was also designed to withstand the forces of flood waters in the event of the PMF.

Since the fishway and dam were considered to be the two separate structures that were incorporated through this design, cost estimates were completed comparing the construction costs of installing both structures simultaneously, or completing one and then completing the second at a later time. It was found to be most cost effective to construct both structures at the same time. According to estimates, this would save approximately \$ 86,500.

### 4.1 Hydrologic Analysis

#### *HEC-HMS Output Data*

Once the model was run, provided there were no issues with incorrect parameters, a “Global Summary Table” was produced. This table listed the peak discharge (cfs) for the given conditions. The Global Summary Table also lists the time at which this peak discharge took place throughout the simulated storm. Figure 37 captures this information.

This information, primarily the peak flow that results from this analysis, can now be utilized in the hydraulic and structural analysis and design. As shown below, the final peak flow determined by the HEC-HMS software was calculated to be 6,211 cfs.

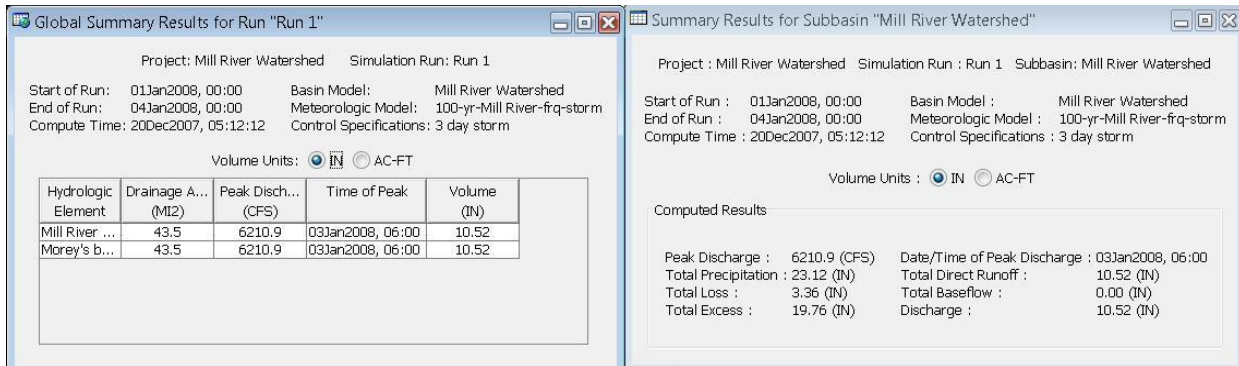

Figure 37. Global Summary Table.

By running the HEC-HMS model, a unit hydrograph was produced that represents the flow patterns associated throughout the Probable Maximum Storm. (PMS) The figure below illustrates the maximum flow associated with the Probable Maximum Storm.

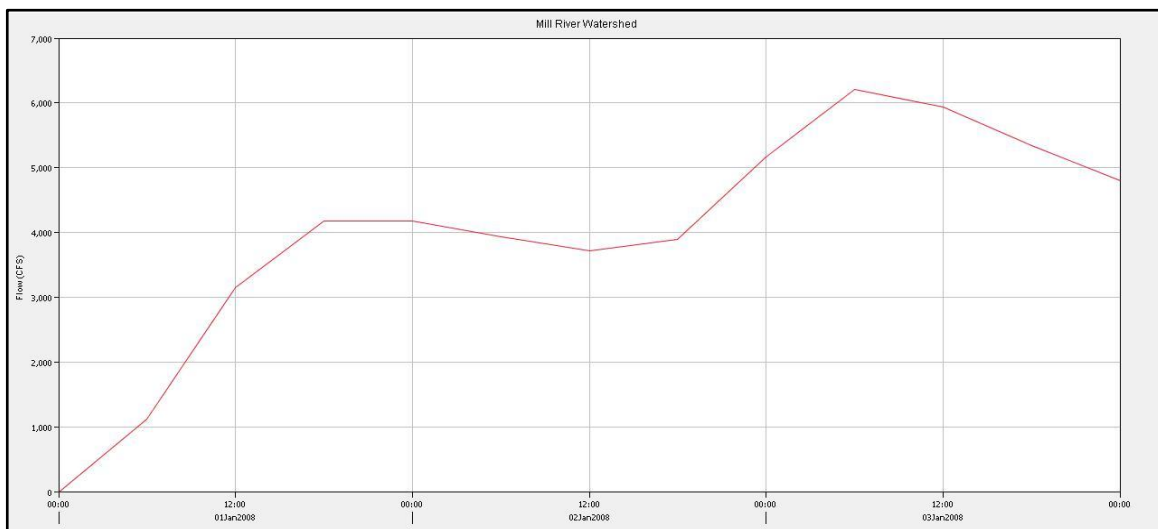

Figure 38. Mill River Watershed Runoff Hydrograph at Morey's Bridge Dam for PMS

The hydrograph shows that the peak discharge for the PMS over the Mill River Watershed occurs at approximately 06:00 on day 3 of the storm. Initially, the peak flow is increasing at a steady rate due to the fact that less and less rainfall is retained by the watershed. Upon reaching its first peak at 18:00 on Day 1, it can be seen that there is a slight decrease as the storm enters day 2. One possible reason for this is that the storm intensity decreased slightly. If the intensity had stayed the same or decreased, the peak flow would have continued to stay the same for a longer period of time, and decreased as the storm was ending. However, due to the dramatic increase in rainfall on Day 2, the flow again began to increase. Once the intensity had subsided, the peak flow at the Morey's Bridge Dam site began to decrease as there was less and less rainfall for the watershed to retain.

This flow is a reasonable value in terms of designing for a Probable Maximum Flow (PMF). Historical data of the nearby Wading River, which has similar characteristics, does not have a daily maximum flow above 2,000. However, compared to other historical floods along other gauged stations, this value is relatively low. Figure 39 below illustrates the historical maximum flow conditions along certain rivers in the northeastern United States. By plotting these flow values with respect to the drainage area, a maximum flow over a certain drainage area can be estimated. The maximum flow of 6,211 cfs with the given drainage area that determined for the Mill River Watershed by HEC-HMS is relatively low. It was concluded that this value is represented effectively given the historical data and the conditions represented throughout the Mill River Watershed. (United States Geologic Survey (USGS) 2007)

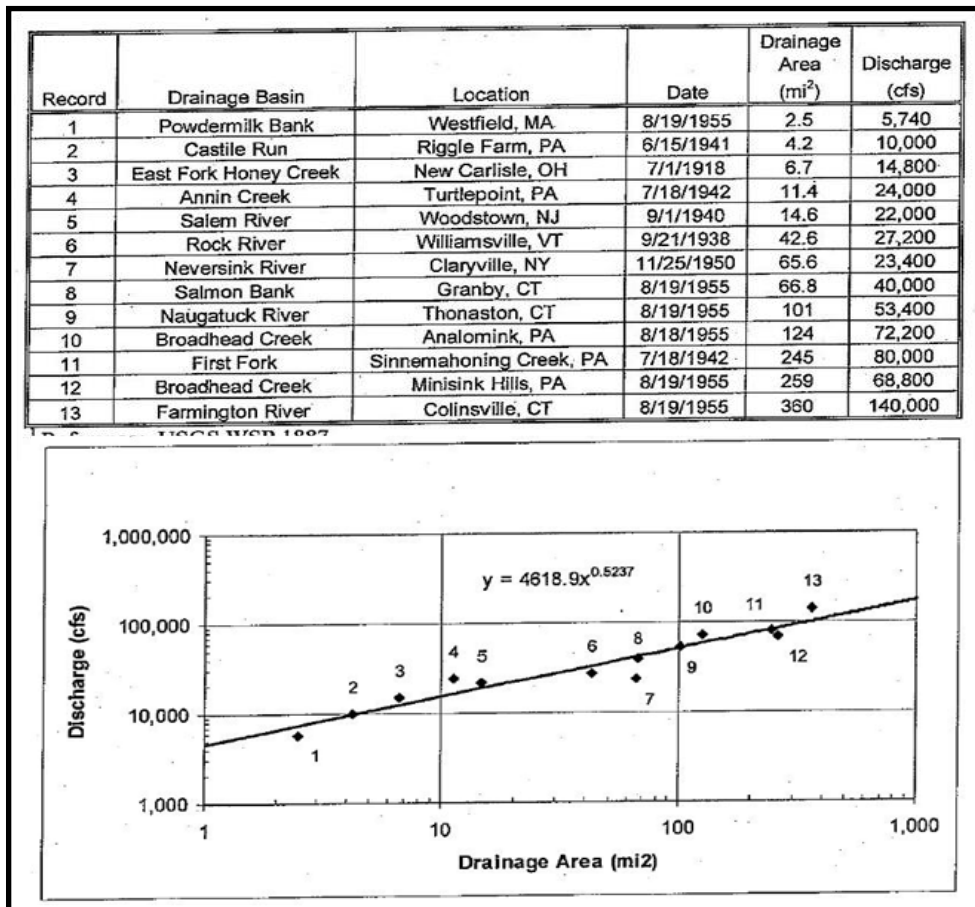

Figure 39. Drainage Area vs. Maximum Historical Flows



The subsequent maximum flow that needed to be determined was the maximum flow in order for the hydraulic design of the dam to function properly. Through historical maps, a flow of 2000 cfs was initially used when analyzing the dam hydraulically. Using historical rainfall data

Precipitation

**Name: 100-yr-Mill River-frq-storm**

Probability: 1 Percent

Output Type: Annual Duration

Intensity Duration: 1 Hour

Storm Duration: 4 Days

Intensity Position: 50 Percent

Storm Area (MI2) 44.0

5 Minutes (IN)

15 Minutes (IN)

1 Hour (IN) 2.8000

2 Hours (IN) 3.5000

3 Hours (IN) 3.9000

6 Hours (IN) 4.9000

12 Hours (IN) 6.0000

1 day (IN) 7.0000

2 Days (IN) 9.0000

4 Days (IN) 10.0000

7 Days (IN)

10 Days (IN)

Figure 40. Rainfall data from USWB TP 40 for Taunton Watershed.

from a technical paper produced by the United States Weather Bureau, frequency rainfall amounts of the Taunton Watershed were input into HEC-HMS to determine what the peak flow at the Morey's Bridge Dam site would be given this rainfall data. This data was entered rather than taking the data obtained from the HMR52 software. When the model was executed, both the basin characteristics and control specifications remained the same. Figure 40 shows the rainfall data entered into HEC-HMS.

The model was run in HEC-HMS and a summary table and hydrograph was produced with the peak flow being 2051 cfs. Figure 41 shows the summary table of from the HEC-HMS model. Figure 42 illustrates the hydrograph produced from the running the model. This flow of 2051 cfs is reasonable when looking at historical data from the Wading River gauge station. Analyzing the site in terms of this maximum flowrate will ensure that the dam will safely and effectively pass flows under normal high flow rates.

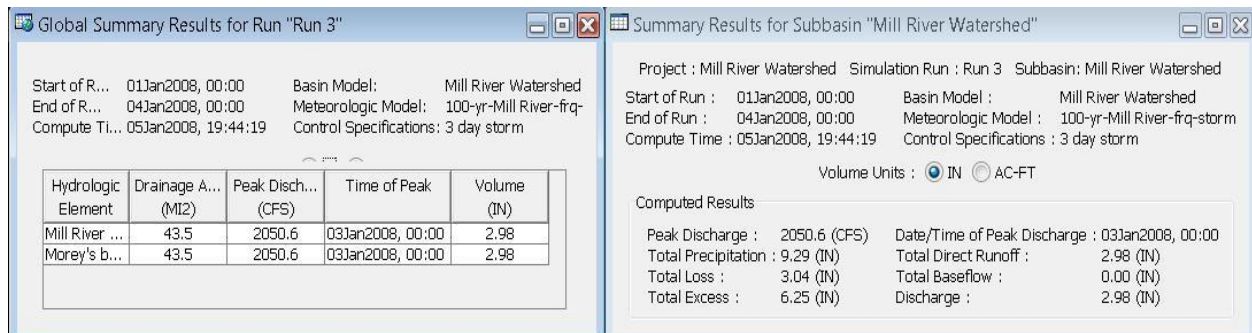

Figure 41. Maximum Flow Associated with Hydraulic Analysis



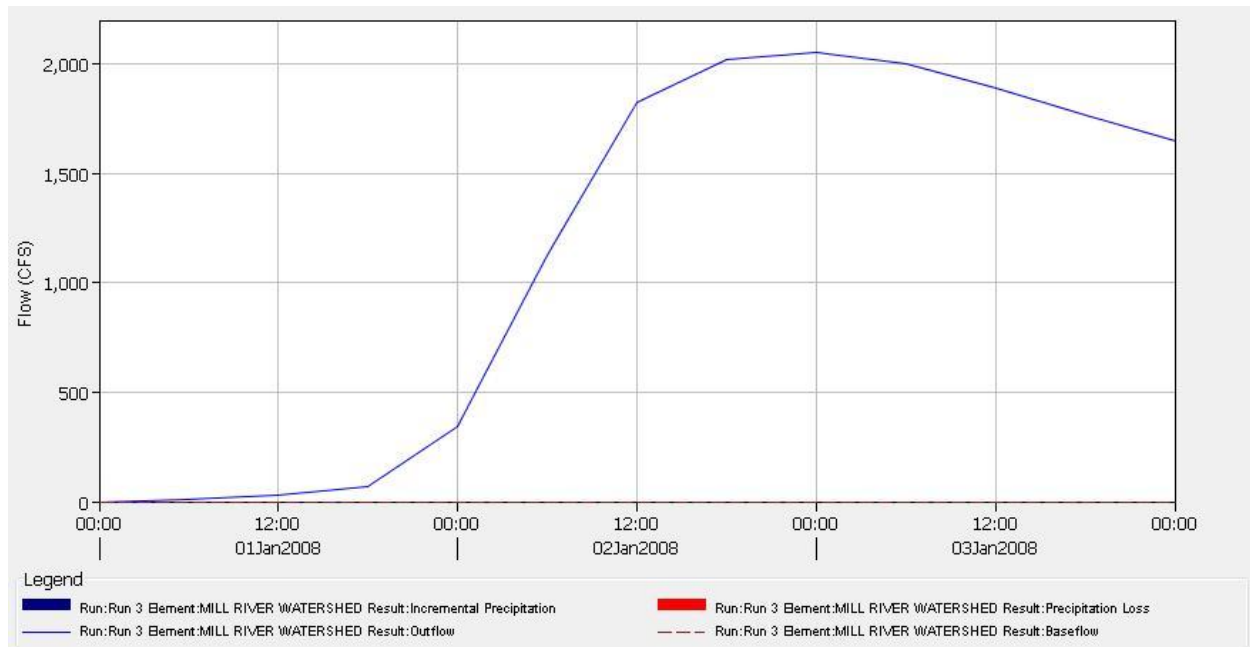

Figure 42. Hydrograph Associated with Hydraulic Maximum Flow

From the graph, it can be seen that the peak flow occurs around the same time as the Probable Maximum Storm flow rates. Although the peak flow is considerably lower than the flow for the PMS, the rate at which the flow increases is initially slower than that of the PMS flow. The reason for this is that the intensity of the rainfall occurs at a much steadier rate than during the PMS.

The rainfall values that were produced from the HMR-52 software were relatively high. The average amount of total precipitation for Massachusetts is 43.84 inches per year. (The World Almanac 1988) The total precipitation produced is almost half of this value. This high value is possibly correlates to the values entered from the HMR-51 isopluvial maps. This value may be high due to the fact that the majority of the HMR-51 rainfall values represent too large of areas seen in Table 7. On the other hand, the calculated peak flow of the PMS is a reasonable value. So although these initial precipitation values seem extremely high, it may still be a fair representation of the Probable Maximum Precipitation during a high intensity storm such as the PMS.

It should also be noted that in both hydrographs, the flow decreases at a much slower rate than it was when it was increasing. The reason for this is that the watershed is saturated. Therefore, the rainfall has nowhere to go other than into the system and to the point of discharge. Over time, the flow rate will decrease and eventually return to its normal condition once the watershed is able to retain the rainfall as it was able to prior to the storm condition.

In addition, the starting date of January 1 and the ending date of January 3 are only reflective of the time that elapsed during the storm. It is not indicative of the weather characteristics surrounding this time.

The CN value of 74 used for the HEC-HMS model included all the land uses containing a Type C soil. The model was run a second time, using the CN value determined from all land uses with Type B soil. Keeping all other factors the same, the peak flow decreases from 6,221 cfs to 5,784 cfs. It can be deduced from the explanation in the methodology, that Type C and Type B soil effects the peak flow enough to alter the peak flow by about 430 cfs for the Morey's Bridge Dam site. Further investigation could follow to determine a more exact value regarding a better understanding of the soil type. For our design, the higher peak flow was used due to the uncertainty of the actual soil type within each land use.

By having justifiable hydrogeological characteristics regarding the Morey's Bridge Dam site, the next steps can be addressed in terms of design criteria, planning, and so on. Additionally, the information obtained through the hydrologic analysis allows for a better understanding of the surrounding area of the site.

#### **4.1.1 Fish passage Hydrology**

Differing from the hydrologic approach to estimate the PMF for the safe design of the dam, the fish passage hydrology was based primarily on flow data from the migration period of the target species. Data were taken from daily, monthly, and annual flow averages of the last 17 years (between 1990- 2006) at the Wading River Stream gauging site near Norton, MA. This data is accessible through the USGS.gov website, where many other stream gauge data can be found and compared to the stream analyzed in this project. An abbreviated form of these flow data can be found in Appendix B, where dates that are not of interest are crossed out in red.

Maximum, minimum and normal flow was determined to define an operating range of flows for the ladder. These flows define the boundaries of the flows under which fish should be able to pass the ladder. Considering the 3 day window of passage, it is important that under extreme high or low flow conditions that may occur within ranging from 15 to 20 years are taken into account. These extreme conditions may persist for an excess of 3 days. These flows may represent an unusually snowy or rainy year, or at the other extreme may represent an unusually dry year. If fish are not able to pass under these conditions, it could result in a dramatic reduction in the population counts for the following years.

Preliminary maximum flows were determined by multiplying the annual average flow by 3. This preliminary high flow value ( $Q_{max}$ ) was compared to the daily flow records for the last 17 years, and days where  $Q_{max}$  is exceeded were noted. These data are recorded in Appendix A. Periods of more than one day were of specific interest, because a high frequency of the preliminary  $Q_{max}$  meant that  $Q_{max}$  was too low. The goal was to have a final  $Q_{max}$  for design that would allow fish to pass regardless of average storm events. After reviewing the recorded high flow data,  $Q_{max}$  was set at 350 cfs. At this flow rate, the data collected from the past 17 years show two periods of time longer than 3 days for which the flows exceed 350 cfs.

Likewise, preliminary minimum flows were determined by taking the minimum (99<sup>th</sup> percentile) flows for the last month of the latest migration period analyzed, or May 2006. This preliminary minimum flow value ( $Q_{min}$ ) was compared to the last 17 years of daily flow records, similar to the analytical method of determining an accurate  $Q_{max}$ . Tables showing the process of elimination to determine  $Q_{min}$  can also be found in Appendix A.  $Q_{min}$  was set at 15 cfs.

While maximum and minimum flows were found to define the operating boundaries of the fishway, an average flow value ( $Q_{avg}$ ) was defined to find the average operating conditions for the passage. These were the flows that are primarily designed for, under the assumption that these flows are the closest to day-to-day flows that fish will have to be passed through. These flows were also intended to model the most common migration time period, so calculations for  $Q_{avg}$  were based only on flow records for the month of April. Average operating flows were determined by taking the average of April's average daily means and highest median for the last 17 years of daily flows. By taking the mean of April daily medians for the years between 1990 and 2006,  $Q_{avg}$  was determined to be 140 cfs.

Table 11. Summary of fishway design flows.

$Q_{min}$	15 cfs
$Q_{avg}$	140 cfs
$Q_{high}$	350 cfs

It is important to note that the fishway design flows differ from the approach and values of the dam design flows and PMF. These flows were intended to find the design flowrate for only the migration period of the target species and not for year round flows or unusually high flows (such as the PMF).

## 4.2 Hydraulic Analysis

Hydraulic analysis involved applying the design equations to find depths and velocities of the water at different sections of the channel under different flow scenarios. For the dam design, this consisted of a low flow of 10 cfs, and average flow of 100 cfs, a high flow of 2000 cfs, and a PMF flow of 8000 cfs. The equations from Table 8 were applied through a spreadsheet in Microsoft Excel. Detailed calculations through this spreadsheet can be found in Appendix C.

The tail water section was analyzed first because the heights and flow conditions of the tail water have an effect on the conditions at the spillway. Key information to find was the low, average, and high flows for this section. These flows were estimated by reviewing gauge station data along the Wading River. USACE HMR-51 and HMR-52 were used to estimate Probable Maximum Flows. The maximum flow data can be found in Section 3.1 of this report.

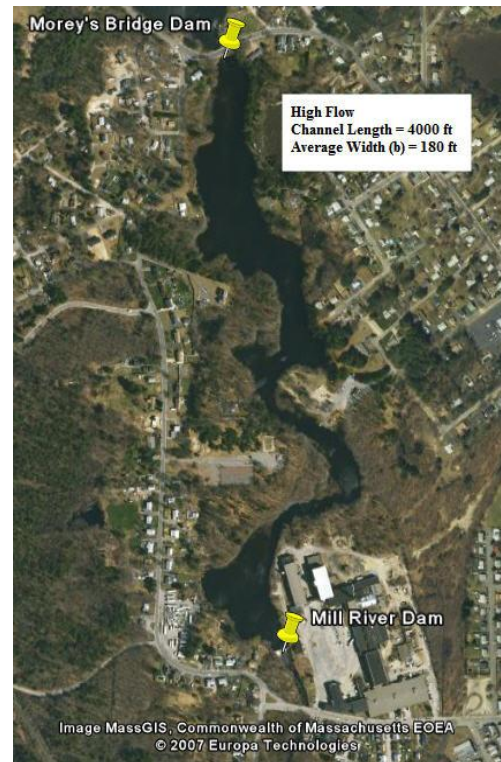

Figure 43. Google Earth Image of tail water channel.

### 4.2.1 Tailwater Analysis

The tail water channel cross section was measured using Google Earth. The length was measured to be roughly 4000 feet, and the width averaged at 180 feet under high flows, were used to model channel dimensions. The Google Earth images were not dated, therefore the flow condition was estimated to be at high flow, based on observations of water elevations made at the site under low flow conditions. The channel, though somewhat winding, was modeled as a straight channel for simplification purposes.

Table 12 shows a summary of data for the tail water. The critical depth was calculated based solely on the flow rate, channel width, and the force of gravity. Water velocity was also determined by channel dimensions and flow rate.

Table 12. Tail water Channel Data.

Tail water Data				
	Low Flow	Average Flow	High Flow	PMF Flow
Channel width (b) (ft)=	20	100	180	280
Channel length (ft)=	4000	4000	4000	4000
Flow rate (Q) (cfs)=	10	100	2000	8000
Unit flow rate (q)=	0.5	1	11.1	28.57
Critical depth ( $y_c$ ) (ft)=	0.198	0.314	1.565	2.937
Velocity (V) (ft/s)=	1.98	2.63	6.86	9.99

Next, Manning’s equation was applied and Froude numbers were calculated for the tail water channel using Excel. Manning’s equation was applied to find the normal depth of the water. The Froude number was found to determine whether the depth was sub or supercritical. The comparison of Froude number, normal depth, and critical depth yield and estimate of the flow profile, and whether it is slow deep flow (subcritical) or fast shallow flow (supercritical).

The slope of the channel was estimated based on readings from a topographic map and the length measurement from Google Earth. The topographic map showed a maximum elevation difference between Morey’s Bridge dam, and the Mill River Dam (both highlighted in Figure 43) to be 3 meters, converted to 9.68 feet. Using this elevation difference and a channel length of 4000 feet, the average channel slope was calculated as 0.00246 ft/ft. This average slope was used for all hydraulic calculations except for the spillway calculations. The roughness coefficient was found from Manning’s Roughness Coefficient tables (Hwang 1996). The roughness was based on a natural channel, with pebbles, sand, and some grass. The unit flow rate is simply a value of flow rate per unit width of the channel. The channel was modeled as rectangular. These findings for all three flow conditions are summarized in the following table.

Table 13. Manning's Equation Data for Tail water.

Manning's Equation Data for Tail water				
	Low Flow	Average Flow	High Flow	PMF Flow
Unit flow rate (q)=	0.504	1.002	11.115	28.572
Roughness coefficient (n)=	0.04	0.04	0.04	0.04
Normal depth ( $y_n$ ) (ft)=	0.254	0.381	1.621	2.859
Slope ( $S_0$ )=	0.00246	0.00246	0.00246	0.00246
Flow rate (Q) (cfs)=	10	100	2000	8000
Froude Number ( $F_r$ )=	0.492	0.463	0.362	0.329

#### 4.2.2 Spillway Analysis

Next, the spillway conditions were calculated. These calculations were based on the dimensions of the spillway structure. Design information found in the Sturm text (Sturm 2001), was used to model the spillway was modeled as a sharp crested weir. This translates into the slope of this spillway following the nappe of the discharge, termed an ogee spillway. This design information will be used in the Structural analysis. Using this spillway model, the discharge conditions calculated at the crest of the spillway were applied to Manning's Equation to find the flow conditions at the toe of the spillway. Table 14 shows the head conditions calculated with the spillway equation. Head values shown for low, average, and high flows were calculated assuming a negligible approach velocity at the crest of the spillway. Considering that during the probable maximum flood, it is unreasonable to consider the approach velocity to be zero, it was set at a value between 15 fs and 20 fs to allow for fluctuations in the velocity. This change in approach velocity increased the  $H_a$  but the actual height of water traveling over the dam is more likely to be closer to 3 feet, which is used in the structural calculations.

Table 14. Spillway Equation Values.

Spillway Equation Data (sharp crested weir/ ogee spillway)				
	Low Flow	Average Flow	High Flow	PMF Flow
Head ( $H_a$ ) (ft)=	0.1	0.45	3.166	7.97
Coefficient of Discharge ( $C_d$ )=	3.23	3.27	3.55	3.56
Length of crest (ft)=	100	100	100	100

Using the flow values from the spillway equation, Manning’s Equation was applied to find normal depths and velocities under all three flows, and compared to the critical depths calculated for this section. The steps for applying Manning’s Equation to find the normal depth, and calculating the Froude number and critical depths is similar to the process described for the tail water analysis. The slope for the spillway was set at 0.85. The value of 0.85 was initially set during the hydraulic analysis, and checking the value against structural design guidelines specifying that the ratio of dam height to base width must be between 0.75 and 0.95, the spillway slope of 0.85 is a reasonable value. (For purposes of this analysis, the spillway slope was simplified as straight, and not exactly following the curved nappe that can be expected with a free discharge.) A spillway of this slope has a 3.5 foot elevation from the base to the crest, and a base that is approximately 4 feet wide. Other specific spillway characteristics are described in the Structural Analysis section. Table 15 shows calculated values for the toe of the spillway under all three flow conditions.

**Table 15. Manning's Equation Values at Spillway Toe.**

Manning’s Equation Applied at Toe of Spillway				
	Low Flow	Average Flow	High Flow	PMF Flow
Unit flow rate (q)=	0.10	1.00	20.05	80.25
Roughness coefficient (n)=	0.013	0.013	0.013	0.013
Normal depth ( $y_n$ ) (ft)=	0.015	0.06	0.364	0.839
Slope ( $S_0$ )=	0.85	0.85	0.85	0.85
Flow rate (Q) (cfs)=	10	100	2000	8000
Velocity (V) (ft/s)=	6.6	16.63	55.08	95.51
Froude Number ( $F_r$ )=	3.697	2.934	2.168	1.880
Critical Depth ( $y_c$ ) (ft)=	0.069	0.312	2.316	5.848

### **Calculation of Hydraulic Jump Location**

As the width of the channel passing under the bridge presented a constriction on the channel, it was necessary to calculate flow conditions underneath the bridge. The width of the spillway is 100 ft and the width of the channel passing underneath the bridge is 40 feet.

The depth of the water flowing beneath the bridge was calculated using plots showing the depths and velocities calculated using the energy equation from downstream and upstream. The constriction depths and velocities were graphed, using the subsequent hydraulic jump depth, and the expansion depths and velocities were calculated and compared on the same plot. These two curves would intersect at the conditions expected under the bridge, as long as

the subsequent hydraulic jump depths were correct. The intersection of curves in Figure 44 is an example where the subsequent hydraulic depth yielded an accurate representation of the flow profile of the channel. This plot indicates that the depth of the flow under the bridge can be expected to be 0.275 ft. The constriction curves differ by the location of the hydraulic jump. Intersection between curves in these plots indicates that the method used to model the hydraulic jump was correct. Lack of intersection among these curves indicates that the subsequent hydraulic depth is greater than calculated through the force/ momentum equation. The location of the hydraulic jump is specified in Figure 44, Figure 45, and Figure 46 by the width of the channel where they occur. For example, a hydraulic jump occurring at 70 ft occurs where the channel is 70 feet wide, between the toe of the spillway and the bridge. Using a force and momentum balance, the hydraulic jump subsequent depths and water velocities were calculated, assuming that the jump occurred in a location between the spillway toe and the bridge. The initial depth was assumed to be the depth at the toe of the spillway. Since the Froude Number is part of the Hydraulic Jump Equation, the channel width has an impact of subsequent depths. Curves were plotted for channel widths of 100 feet, 90 feet, 70 feet, 60 feet, and 50 feet, depending on the flow rate. Table 16 shows subsequent depths for hydraulic jumps occurring at a point where the channel width is 70 feet (approximately halfway between the spillway toe and the bridge channel). These were the starting values for the hydraulic jump analysis.

Table 16. Hydraulic Jump Calculations

Hydraulic Jump Depths and Froude Numbers				
	Low Flow	Average Flow	High Flow	PMF Flow
Initial depth ( $d_1$ ) (ft)=	0.015	0.06	0.364	0.839
Subsequent depth ( $d_2$ ) (ft)=	0.071	0.221	0.949	1.850
Froude Number ( $F_r$ )	3.697	2.934	2.168	1.880

Using the subsequent depths and velocities, plots were made to compare these values to the Froude values were applied to predict the flow conditions for the channel underneath the bridge. These values were applied to the constricted side of the channel, utilizing a constriction coefficient of 0.5 for head loss. On the tail water side, the energy equation was applied utilizing the expansion head loss coefficient on 1.0. These values differ from the head loss coefficient values found in the USACE hydraulic guidelines of  $C_c=0.1$  and  $C_e=0.2$  because it was suspected that the flow could be more accurately modeled by increasing these values. However, setting  $C_e=1.0$  is still twice the head loss that is experienced through the constriction ( $C_c=0.5$ ). These two balances were plotted on the same chart (per flow rate) and compared.



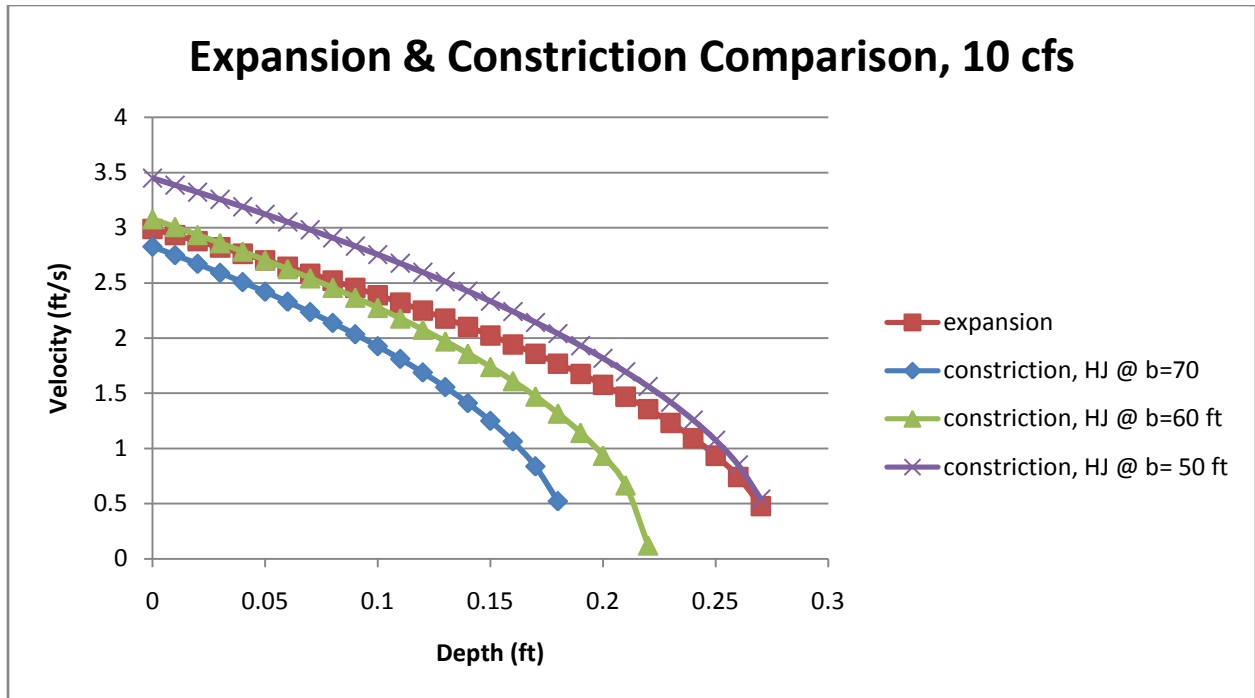

Figure 44. Expansion and Constriction Comparison, low flows.

As shown by the intersection of the expansion and constriction curves in Figure 44, it was most likely that the hydraulic jump occurred where the channel is 50-60 feet wide, before the bridge. This was interpreted through the intersection of the expansion curve with the constriction curves calculated with the subsequent hydraulic jump depths at locations where the channel is 50 feet wide and 60 feet wide, at a depth of approximately 0.275. Under low flow conditions, the conditions in the channel passing underneath the bridge can be expected to be under 0.3 feet deep, with velocities under 3 ft/s.

Using the same procedure, Figure 45 and Figure 46 can be interpreted in a similar manner to deduce the location of the hydraulic jump. Figure 45 and Figure 46 show the comparison of depths and velocities under high and average flow conditions.

The fact that these curves do not intersect as they did under low flow conditions suggests that it is likely that a hydraulic jump does not occur with a subsequent depth as modeled with the force momentum equation, and the spillway discharges into a channel with the water backed up in it.

Under these conditions, there is still a high energy dissipation at the toe of the of the spillway before the flow reaches the bridge, however it cannot be modeled with the force/ momentum balance applied because the energy dissipation does not occur through a hydraulic jump where force and momentum energies balance. This energy dissipation can be modeled more accurately by free discharge, where much energy is lost where the discharge stream meets the pool of water below it, and there is a more gradual transition to the tailwater conditions.



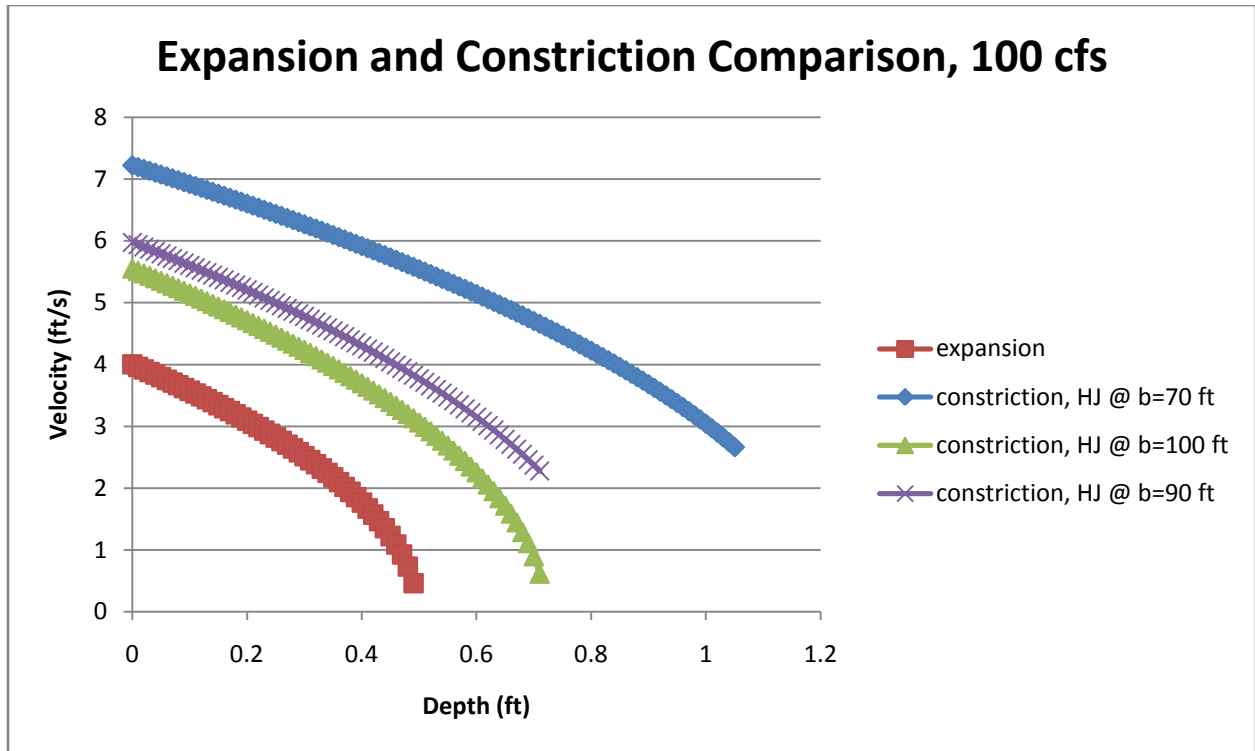

Figure 45. Expansion and Constriction Comparison, average flows.



Figure 46. Expansion and Constriction Comparison, high flows.

### 4.2.3 Fish Passage Hydraulics

Critical flows to analyze in fishway design are the head at the entrance and exit of the fishway channel. These values are important to compare to the depths and velocities that the target species is capable of swimming.

The first value to be established was the head at the exit channel. Values shown in Table 17 were selected from Figure 67 (located in Appendix C), approximately halfway between the plots for Froude number 0.9 and Froude number 0.1. These Froude values were selected as a basis for estimating flow conditions under a subcritical flow. As these conditions can vary significantly, these values for depth and velocity were selected as a starting point for analysis. The resulting depths from this analysis would be used to design how far the fishway would be set into the dam.

These depths would occur in the fishway channel if the floor of the channel were set flush with the crest of the spillway. By setting the channel deeper into the spillway, greater depths can be achieved in the exit channel. This significantly impacts design because alewife are primarily a swimming species, not a jumping species, and the depths flowing through the fishway channel must compliment the alewives' swimming capabilities.

Letting the width of the fishway channel equal 4 feet sets the flow travelling through this channel at approximately 4 percent of the total flow travelling over the spillway. Thus, at flow rates of concern, namely 15 cfs, 140 cfs, and 350 cfs, the flows expected in the fishway channel are 0.45 cfs, 4.2 cfs, and 10.45 cfs, respectively. Reading these values from Figure 48, expected depths ( $h_u$ ) at the fishway exit are 0.3 feet, 1.85 feet, and 2.25 feet, respectively. These depths are summarized in Table 17.

Table 17. Velocities and Depths at Crest.

Likely Depths at Crest of Spillway and Fishway Entrance					
Flow (ft <sup>3</sup> /s)	Velocity (ft/s)	Depth at crest (ft)	$H_u$ values from flow rate equation (ft)	Depth with set in of 1.5 feet	Velocity at first baffle (f/s)
15	0.6	0.2	0.3	1.7	1.3
140	1.6	0.8	1.1	2.3	2.2
350	2.7	1.2	1.85	2.7	2.6

Setting the channel 1.5 feet into the spillway structure (from the crest) results in greater depths at the fishway exit. These depths will become greater at the base of the fishway channel, where energy dissipation will have occurred through the series of baffles set into the channel.

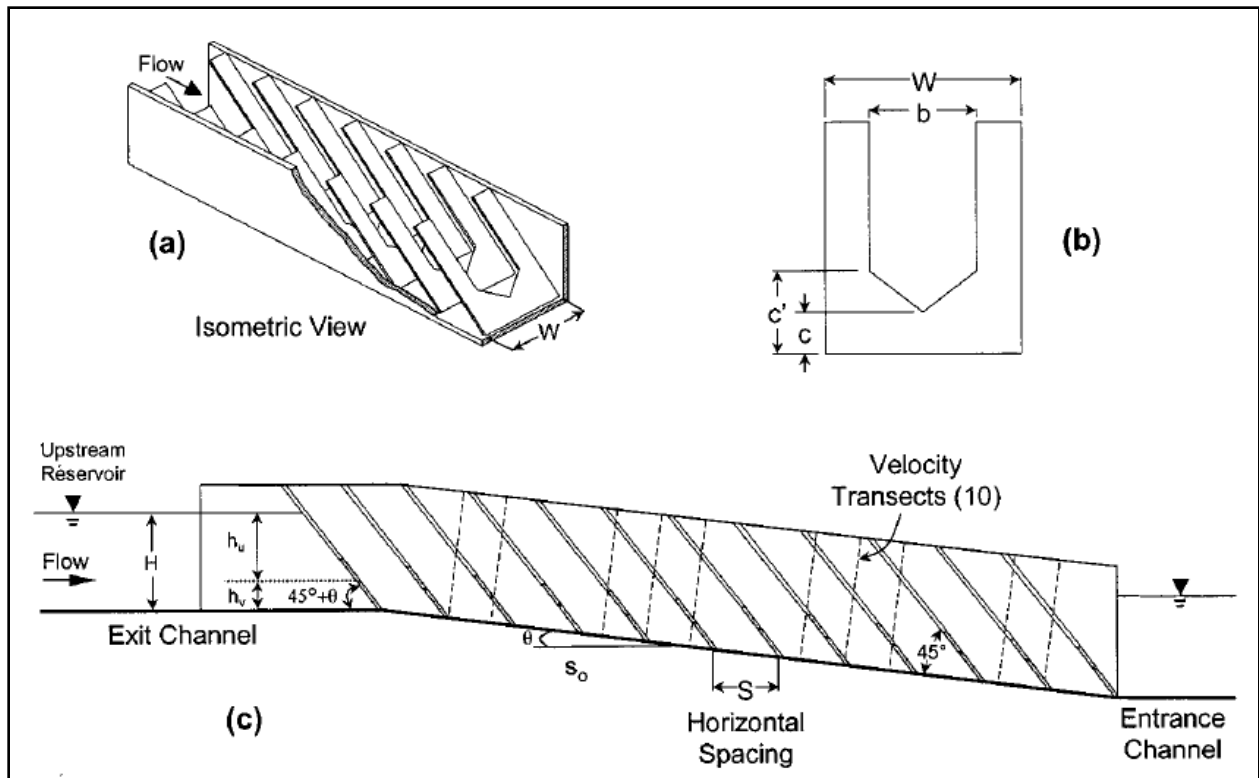

Figure 47. Denil fishway section views. (Odeh 2003)

The velocity of the water flowing over the first baffle was of concern. Figure 48 was plotted based on the flow rate equation (Odeh 2003) where the flow rate values were plotted versus the head over the baffle, denoted as  $h_u$  in Figure 47. Since it can be expected that the flow travelling through the fishway will be a fraction of the flow travelling over the entire spillway, and this ratio can be found by finding the percent of the width of the fishway out of the span of

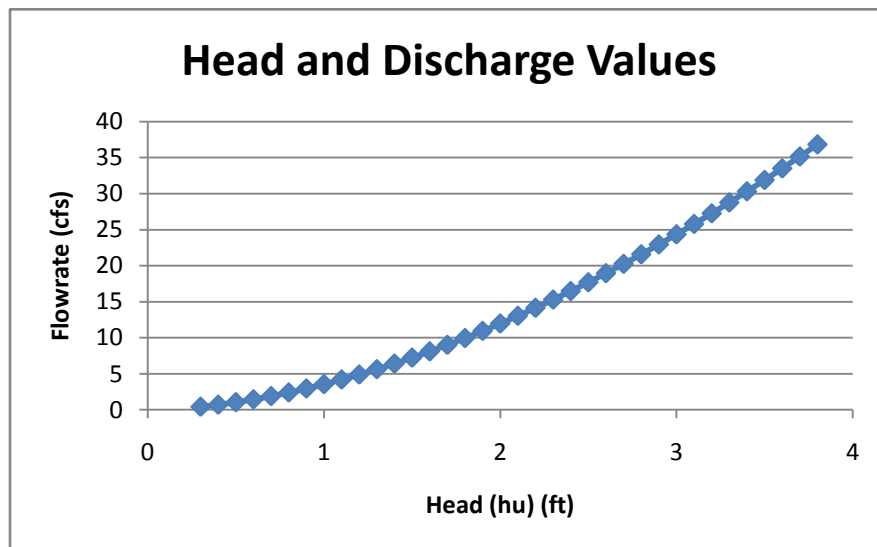

Figure 48. Fishway Head and Discharge Values at first baffle.

the entire spillway, that portion of the flow will be searched for on the chart to find the corresponding head over the v-notch of the first baffle ( $h_u$ ).

The velocities of the water in the fishway channel will be highest at the first baffle. Using the flow equation, these values can be calculated.

By reading the plot, the flowrate at a head of 1.7 ft is approximately 7 cfs. This had a velocity traveling through the fishway of 1.3 feet per

second. The velocities at the first baffle under the other two flowrates of concern were 2.2 ft/s and 2.6 ft/s. As these are the highest velocities throughout the fishway, it was not a concern that the alewife would be able to travel through the fishway because the species is capable of traveling through water up to 5 ft/s.

### 4.3 Structural Design Calculations for the Dam

The structural analysis of the dam and fish passage structures was based on the results of the hydrologic and hydraulic analysis, as well as the guidelines presented through ACI and USACE. Although some information was available through the coffer dam drawings, some assumptions had to be made to complete the structural design analysis. These assumptions are:

- The structure is supported by an impervious foundation
- The structure is a concrete gravity dam with an overflow spillway
- Dam structure is assumed to be triangular for design
- Concrete density is 150 lb/cf
- Concrete strength is 3500 psi
- Water density is 62.4 lb/cf or
- Velocity is uniform over the entire 100' length
- Slope of the base of the dam = 0
- Height of water flowing over the crest of the dam is 3 ft ( for MPF)

Maximum Probable Flood (from hydrologic analysis) = 8000 cfs

#### 4.3.1 Load Calculations

After all these assumptions were taken into consideration, we calculated all the loads.

##### Dead Load

$$DL = \frac{BH}{2} * 150 \text{ lb/cf} = 788 \text{ lb/ft}$$

##### Hydrostatic Loads

Upstream

$$P1 = 62.4 \text{ lb/cf} * 3 \text{ ft} = 188 \text{ lb/sf}$$

$$P2 = 62.4 \text{ lb/cf} * 6.5 \text{ ft} = 405.6 \text{ lb/ft}$$

$$F1 = 188 \text{ lb/sf} * 3.5 \text{ ft} = 655 \text{ lb/ft}$$

$$F2 = (405 - 188) * 3.5 \text{ ft} / 2 = 382.2 \text{ lb/ft}$$

$$F1 + F2 = 1037.4 \text{ lb/ft}$$

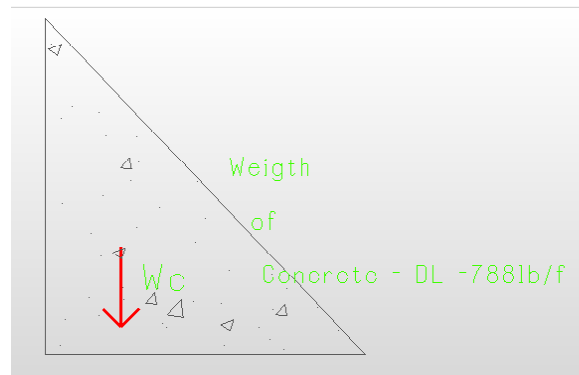

Figure 49. Dead load.

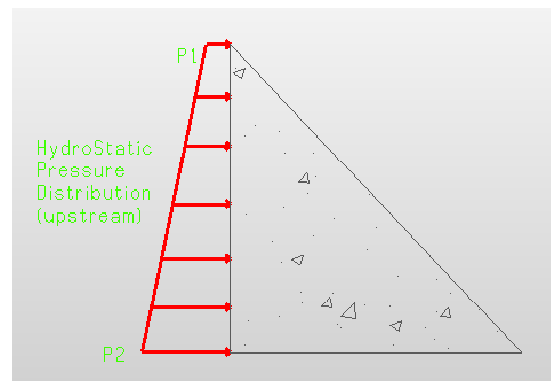

Figure 50. Upstream hydrostatic loads

## Downstream

$$P=175 \text{ lb/sf}$$

$$F=245 \text{ lb/ft}$$

## Uplift Loads

$$U1 = \gamma_w * H1 = 405.6 \text{ lb/sf}$$

$$F1 = 228.4 * 1 = 228.4 \text{ lb/ft}$$

$$U2 = \gamma_w * H2 = 174.7 \text{ lb/sf}$$

$$F2 = (405.6 - 228.4) * 1 = 177.2 \text{ lb/ft}$$

$$U4 = \text{larger of } U2 \text{ and } 72.4 \text{ lb/sf}$$

$$F3 = 174.7 * 2 = 355.4 \text{ lb/ft} ; F4 = 53.7 \text{ lb/ft}$$

$$U3 = 0.7(405.6 - 174.7) * \frac{1}{3} + 174.7$$

Assuming  $e = 30\%$

$$F1 + F2 + F3 + F4 = 814.7 \text{ lb/ft}$$

## Nappe Force

For the nappe force, the velocity of the water flowing over the top of the dam had to be considered, but taking into account that the velocity at 3ft over the crest of the dam is not the same as the one right at the crest. The nappe force is a momentum force based on upstream and downstream conditions. For this calculation the flow  $Q=8000\text{cfs}$ , which was the maximum probably flood obtained in the hydraulic analysis, was divided by the cross sectional area of  $300\text{sf}$ , which was based on the 100 ft length times the 3 ft of water flowing over the structure. This gave us a velocity of 26 ft/s at 3ft over the crest. The velocity throughout the entire height of the dam is 0 since the structure acts as a retaining wall.

To calculate the nappe force on the structure, it was necessary to apply the momentum principle. The following equation is the momentum principle. With this condition, the velocity difference was found and then the hydraulic equation for the nappe force could be used.

$$F1 - F2 - F_x = \rho Q \Delta V \quad (\text{hydraulic equation for nappe force using momentum principle})$$

$F1$ = upstream hydrostatic pressure

$F2$ =downstream hydrostatic pressure

$F_x$ = force of the structure on water

## Momentum Principle

$$H1V1 = H2V2 = 6.5 \text{ ft} * 26 \text{ ft/s} = 2.8 \text{ ft} * V2; \text{ so } V2 = 60 \text{ ft/s}, \text{ and } \Delta V = 34 \text{ ft/s}$$

Using the hydraulic equation for nappe force:

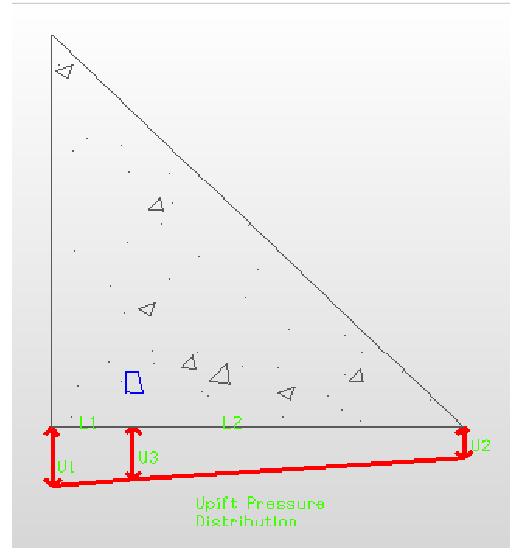

Figure 51. Uplift pressure.

$$F1 - F2 - Fx = \rho Q \Delta V = 1037 \text{ lb/ft} - 245 \text{ lb/ft} - Fx$$

$Fx = 266 \text{ lb/ft}$ , so the nappe force is equal to  $-266 \text{ lb/ft}$ . The nappe force can be considered as a live load.

Earthquake Load (E)

The ground acceleration for the earthquake loads is  $a=0.1g$

The Earthquake pressure is 
$$Pe = \frac{a}{g} * \gamma c * B$$
;

And the earthquake load is 
$$E = Pe * \frac{H}{2}$$

In this case  $E = 78.75 \text{ lb/ft}$  acting at  $0.1\text{ft}$  up from the heel of the dam.

Table 18. Summary of all the loads results\*\*

Force Description	X-direction(lb/ft)	Distance(ft)	Y-direction(lb/ft)	Distance(ft)	Moment@0,0 Lb-ft
Dead Load			-788	101	-79588
Reservoir Load	1037	101.1			-104841
Tailwater	-245	101.4			-24843
Uplift			814	101.2	-82377
Nappe	-266			103.5	-21321
Earthquake	78.75	100.1			7882.88

\*\* Heel of the dam is at 100,100 intercept

### Gravity Method Analysis (Sliding factor of Safety)

$$FS = \frac{\sum Fy \tan(\phi + \alpha)}{\sum Fx}$$
 ; where  $\alpha$  is the slip plane angle and  $\phi$  is the internal friction angle for the foundation. The Army Corps of Engineers recommends to use  $\alpha=0$  and  $\phi=45^\circ$  for stability analysis of gravity dams. (United States Army Copr of Engineers 2005)

$$FS = \frac{1602}{606} = 2.64 > 2.0$$
 ; this shows that the structure is stable.

The total momentum acting in the upstream direction (negative momentum) is greater than the total momentum acting in the opposite direction (downstream direction), which means that the structure is stable against overturning.

When the FS equation that considers earthquake loadings was applied,

$$FS = \frac{CA + (W - U) \tan(\phi)}{\pm Hs + Hd + \left(\frac{W}{g}\right) * a}$$
, with  $C=0$ , and  $\phi=0$ ,  $FS= 8.01$  was calculated. This also shows that

the structure is stable.

### **Unfactored Loading Combinations**

Using equations 16 to 19, the unfactored loads were calculated to choose the combination that controls the design.

**Equation 16**

$$U = 1.3 * 1.7(DL + LL) = 2022.15 \text{ lb/ ft}$$

**Equation 17**

$$U = 1.3 * 1.7 * E = 174 \text{ lb/ ft}$$

**Equation 18**

$$U = 1.3(1.4DL + 1.7LL) = 1714 \text{ lb/ ft}$$

**Equation 19**

$$U = 0.75(1.3(1.4(DL + LL)) + 1.5E) = 1337.6 \text{ lb/ ft}$$

The loading combination that controls the design is the equation 10, with 2000.15 lb/ft; this value is used for the reinforcement design.

For the design, the ultimate moment was  $Wu * L^2 / 8$ , and the area of steel required is:

**Equation 20**

$$As = \frac{Mu}{\phi f_y j d}$$

The ultimate strength  $Vu$  has to be less than or equal to the nominal shear strength  $Vn$  times the reduction factor  $\Phi = 0.75$ , and  $\Phi Vn$  has to be less than or equal to shear strength of concrete divided by 2.

$$Mu = \frac{Wu * l * l}{8} = \frac{2022 * 100 * 100}{8} = 2527.5 \text{ lb - ft}$$

$$As = \frac{Mu}{\phi f_y j d} = \frac{2527.5}{0.9 * 60 * 144 * 2.8} = 0.12 \text{ sf} = 16.72 \text{ in}^2$$

Considering the structure as a wall, vertical and horizontal reinforcement is designed.

The required minimum areas for these reinforcements are 0.0012  $A_g$  and 0.0020  $A_g$  for vertical and horizontal reinforcement respectively. The minimum thickness for the wall is 1/25 of the shorter of the unsupported height or the length, so the minimum thickness for this design is

$\frac{1}{25} * 3.5 \text{ ft} * 12 \text{ in} \approx 2''$ , but because the minimum thickness given by ACI section 14.5.3.1 is 8", the design is governed by this thickness.

According to Army Corps of Engineers, EM 1110-2-2104, Aug 2003, when considering reinforcement for cracking the minimum bar size and spacing is #6 at 12" on center, so Number 6 steel bars are chosen for reinforcement.

Assuming that vertical reinforcement is placed in a single layer of vertical No 6 bars,

$A_v = 0.44 \text{ in}^2$ , and the spacing is  $s(v) = Ah / (0.0020t) = 0.44 \text{ in}^2 / (0.0012 * 8 \text{ in}) = 27.5 \text{ in}$ , and  $s(h) = A_v / (0.0012t) = 45.8 \text{ in}$ .

If we try a smaller size bar, like No 4 bars,  $A_v = 0.20 \text{ in}^2$  and the spacing is  $s(v) = Ah / (0.0020t) = 0.20 \text{ in}^2 / (0.0020 * 8 \text{ in}) = 20.8 \text{ in}$ , and  $s(h) = A_v / (0.0012t) = 0.20 \text{ in}^2 / (0.0012 * 8 \text{ in}) = 12.5 \text{ in}$  on center.

The gross area of the wall ( $A_g$ ) is  $5.25 \text{ ft}^2$  and  $0.01A_g$  is  $7.56 \text{ in}^2$ , so the area of vertical steel ( $A_v = 0.20 \text{ in}^2$ ) is less than  $0.01 A_g$ , which means that the steel provided has an area of :

$A_s = 0.20 \text{ in}^2 / (8 \text{ in} * 18 \text{ in}) = 0.0014$  times the gross area of the wall, so it is a good idea to provide a No. 5 bar vertically at each end of each curtain of wall steel.

The concrete gravity dam structure was designed to be supported by an impervious foundation, which means that the structure won't be affected by seepage. If seepage effects are negligible, the uplift pressure on the structure won't be influenced by seepage effects and the forces created under the structure. According to the Army Corp of Engineers' Gravity Dams Design's standards, in relatively small concrete gravity dams impervious foundations with high bearing strength are essential to prevent the structure from stability failure, that's why we chose this type of foundation for our dam. If the dam's foundation is designed to be impervious the design done in this project won't be affected.

### 4.3.2 Structural Analysis of the Fish Ladder

The fish ladder starts at the top of the dam (crest) and ends at 11.5 ft from the heel of the dam, which is the same as 8.5 ft from the dam's toe. It is at a slope of 6 to 1, and it is being considered as a continuous singly supported beam or channel in this case. The following is the sketch of the structure.

Max. Q going through the fishway plus Q going through the spillway = 350cfs

Max. Q going through the fishway plus Q going through the spillway = 10.5cfs



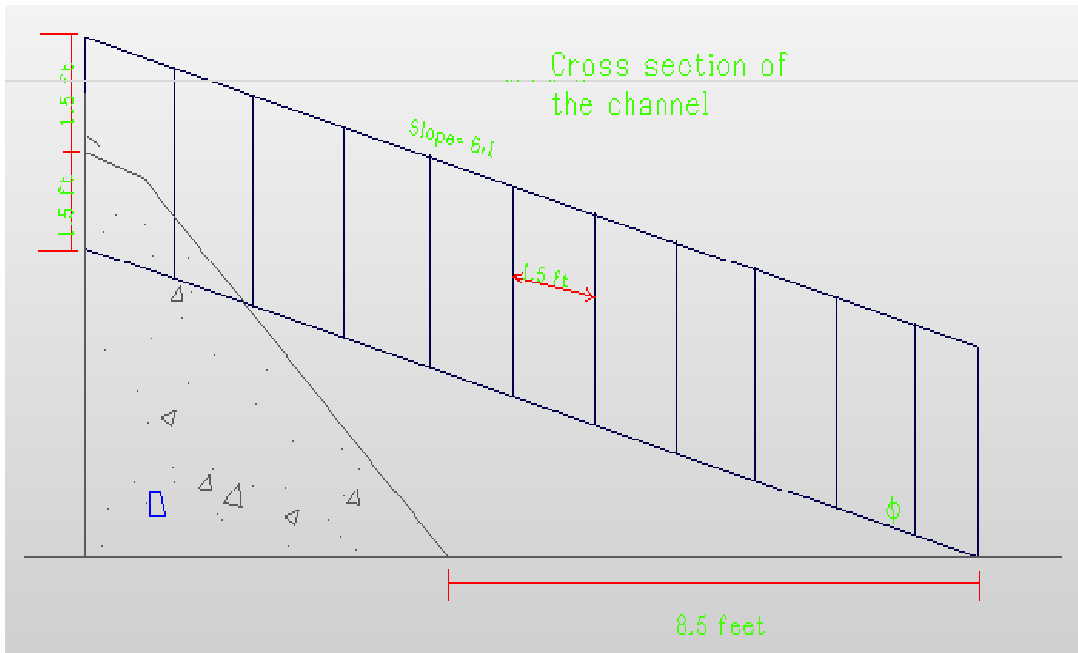
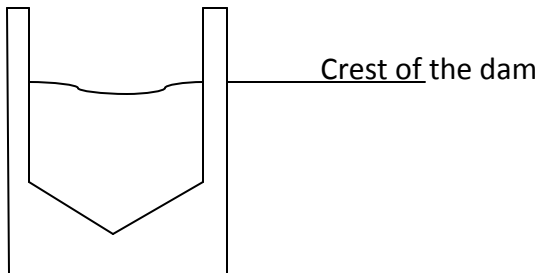

Figure 52. Fishway cross section.



The dimensions for this cross-section were based on the equations provided in the Figure 34 from ASCE (included in the methodology section).

$$b = \frac{7}{12} W; c = \frac{1}{2} W; c' = \frac{1}{4} W; s = \frac{2}{3} W$$

The fish way is 4 ft wide, so  $W=4$  = 4 % of the spillway span, so  $b=2.3$  ft,  $c= 2$  ft,  $c'= 1$  ft.

As in the analysis for the dam, the first step was to determine the loads. In this concrete channel the loads are as follows;

#### Dead Load

$$DL = (W * H) - (b * (H - c')) - \left(\frac{(c' - c) * b}{4}\right) * 150b / cf = 1533b / ft$$

#### Hydrostatic Pressure

Hydrostatic pressure on the walls of the channel

$H_{\text{pressure}} = \gamma_w * H$ , in this case  $H=1.5$  ft and the hydrostatic pressure on the walls of the structure is  $62.4\text{lb/cf} * 1.5\text{ft} = 93.6\text{lb/sf}$ , which yields a load of  $93.6$  lb/ft since analysis is based on a unit (1ft) strip of the channel.

The hydrostatic pressure at the bottom of the channel is  $71.76$  lb/sf, and the hydrostatic load is  $71.76\text{lb/ft}$ . This load is decomposed into x and y components, yielding  $50.74\text{lb/ft}$  in the negative x direction and  $50.74\text{lb/ft}$  in the negative y direction.

Table 19. Summary of the Loads obtained from Analysis

Load Description	X-direction(lb/ft)	Y-direction(lb/ft)
Dead Load		-1533
Hydrostatic Load@wall1	-93.6	
Hydrostatic Load@wall2	93.6	
Hydrostatic Load@bottom1	-50.74	-50.74
Hydrostatic Load@bottom2	50.74	-50.74
$\Sigma F$	0	-1634

The sum of the forces in the x-direction was zero, and the weight of the structure is greater than the sum of the rest of the forces acting on the y-axis, which indicates that the structure is equilibrium. The structure is also stable because it spans from the dam to the channel foundation.

Since the structure is an open channel, it is recommended that bracing be installed at the top of the channel to hold the two walls together. The force needed to hold each wall is  $94$  lb/ft.

### Nappe Force

This is the most important load for this analysis since uplift forces and earthquake loads are not a big concern when the structure is considered a continuous simply supported beam.

For the nappe forces, the momentum principle was also applied and the maximum flow of  $350$  cfs was used, which gives a velocity of  $19.44$  ft/s at the top of the structure.

The velocity difference was  $40.5$  ft/s, which produces a nappe force of  $27.5$  lb/ft

After all these loads are found, the structure can be checked against the sliding; this is done using the sliding safety factor equation (Equation 7 in the structural analysis methodology)

For the reinforcement analysis, the channel was divided into three sections, the two walls and the bottom of the channel. For this section, the unfactored loading equations used in the previous analysis were considered.

Since the main forces are Dead load, Live Load, and Hydrostatic Loads, are only using Equation 21 and Equation 22.

Equation 21

$$U = 1.3 * 1.7(842) = 1860.8lb / ft$$

Equation 22

$$U = 1.3((1.4 * 1533) + (1.7 * 132)) = 3728lb / ft$$

In this case, Equation 21 controls again, and Mu= 37.7 kips.

The area of steel required is :

$$As = \frac{Mu}{\phi yjd} = \frac{37.7}{0.9 * 60 * 144 * 2.04} = 0.0024sf = 0.3si$$

Referencing Table 10 from the structural analysis methodology, three #3 bars are appropriate for each wall.

For the bottom of the channel, there is a dead load of 710 since it carries the load of the walls and the live load at the bottom of the channel is  $(10cfs / (1.5 * 12)) = 0.6$  ft/s; this results in a nappe force at the bottom of the channel of 0.11lb/ft

$$U = 1.3((1.4 * (1533 + 50.74)) + (1.7 * 0.11)) = 2882lb / ft$$

Since Mu was used at the end of the span for the reinforcement of the wall and the end of wall is connected to the end of this section, Mu=33.5kips is used.

$$As = \frac{Mu}{\phi yjd} = \frac{37.7}{0.9 * 60 * 144 * 0.96} = 0.005sf = 0.7si$$

For the bottom section of the channel six #3 bars would be appropriate, aligned in one row.

The total reinforcement area for the channel is  $1.4 \text{ in}^2 + 0.3 \text{ in}^2 = 1.7 \text{ in}^2$ . Three #3 bars in each wall and six No. 6 bars at the bottom could be used. This results in a total of twelve No. 3 bars for the entire channel.

Since this analysis was made independently from the dam analysis, it is recommended that a more detailed analysis combining the two structures together to see the implications.

## 4.4 Cost Analysis

For the cost analysis, some values were estimated, such as the time that each activity would take during construction phase. The cost for the general requirements division was based on a percentage of the total cost. Overhead and Profit were assumed to be 25 % of the total cost, progress and documentation was assumed to be 1% while cost control costs were based on a 0.08% of the total. Under this division were other elements considered such as Inspections, equipment rentals, barriers and enclosure and signs that were also estimated according to the number of days that each element would be utilized on the site.

The second division was site construction. All the elements included in this section were based on experience in this field. A list of all the activities required to complete this type of project was generated, and the time that each activity would take was estimated. The time that each activity would take, multiplied by the cost/ time value given in the RS Means manual gave the total cost per activity. Other elements such as excavation, grading and fill were evaluated based on volume quantities and the cost per unit volume.

The last two divisions, concrete and steel, were estimated according to volume and linear foot respectively.

A summary of all those values is revealed in the following table.

Table 20. Cost Estimate worksheet.

DIVISIONS	COST/UNIT	No. of Units	Unit	TOTAL
<b>DIVISION 1: GENERAL REQUIREMENTS</b>				
<b>SUBDIVISION</b>				
<b>1310 PROJCT MANAGEMENT/ COORDINATION</b>				
620 Overhead & Profit(25%)				\$25,649.67
700 Field Personnel	4935	8	weekly	\$39,480.00
<b>1320 PROGRESS DOCUMENTATION</b>				
200 Scheduling	1%			\$1,025.99
200 Cost Control	0.08%			\$820.79
<b>1321 CONSTRUCTION PHOTOS</b>				
500 Photograph	250	1		\$250.00
<b>1450 QUALITY CONTROL</b>				
500 Testing & Inspectional Service	1,868	1		\$1,868.00
<b>1590 EQUIPMENT RENTAL</b>				\$0.00
100 Restrooms	159	45	per day	\$7,155.00
100 Concrete pump	200	2	per day	\$400.00
100 Manual Gas For Concrete	35	2	day	\$70.00
100 Vibrators	10.65	2	day	\$21.30
100 Concrete Batch Truck	670	2	day	\$1,340.00
200 Earthwork Equipment Rental	1,200	1		\$1,200.00
400 General Equipment	500	45	day	\$22,500.00
<b>1560 BARRIERS &amp; ENCLOSURES</b>				
250 Temporary Fencing	6.75	250	Linear ft	\$1,687.50
<b>1580 PROJECT SIGNS</b>				
700 Signs	16.4	30	sf	\$492.00
<b>DIVISION 2: SITE CONSTRUCTION</b>				
<b>SUBDIVISION</b>				

<b>2110 HAZARD REMOVAL &amp; HANDLING</b>				
300 Heavy Sludge or Dry Vacuumable Material	100	72	hr	\$7,200.00
<b>2240 DEWATERING</b>				
500 Dewatering	7.85	111	cy	\$871.35
<b>2260 EXCAVATION SUPPORT/ PROTECTION</b>				
200 Cofferdams	19.8	350	sf	\$6,930.00
<b>2310 GRADING</b>				
100 Finish Grading	2.37	2400.03	sy	\$5,688.07
<b>2315 EXCAVATION &amp; FILL</b>				
110 Backfill, General	15.25		l.c.y	
<b>DIVISION 3 CONCRETE</b>				
Mass concrete			cy	
Fish Ladder	75	4.7300591		\$354.75
Dam	75	1050.0131		\$78,750.98
<b>DIVISION Metals</b>				
Reinforcement			lb	\$0.00
Fish Ladder	0.45	450		\$202.50
Dam	0.45	5780		\$2,601.00
<b>Total</b>				
				\$206,558.90

The cost distribution chart is as follows:

### Cost Distribution Chart

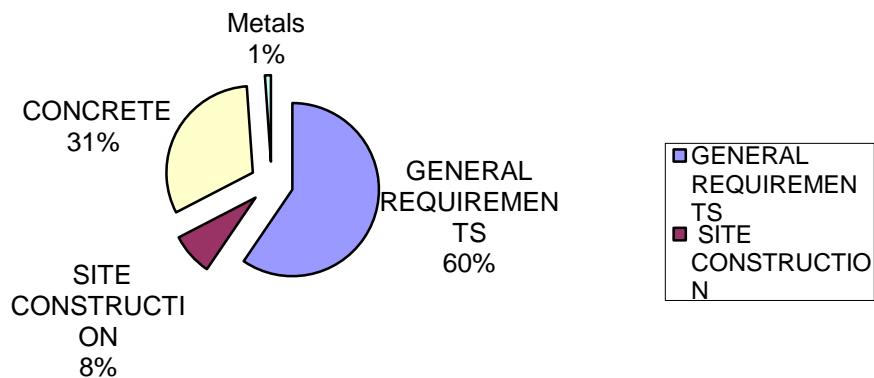

Figure 53. Cost distribution.

The total cost of the project is assuming that both, the fish ladder and the dam are being constructed at the same time. This would save money to the owner since it would only have to pay to general requirements and site construction once.

This cost estimate is also based on the assumption that the location of the current coffer dam leaves sufficient space for construction of the new dam and fishway structures. It is likely that a new coffer dam will be needed to provide more space for dam construction. This step would increase the cost significantly.

## **4.5 Summary of Results**

This section summarizes provides a summary of drawing specifications, strength, stability, durability and service life, and cost. The main disciplines involved in this project were Hydrology, Hydraulics, and Structural Engineering. Determination of the ideal spillway and dam configuration were deduced through background research, where the spatial constraints of the site were taken under consideration. The ideal location for the dam was as close to the coffer dam as possible to allow for utilization of this temporary structure in the construction of the new dam and fishway. Determination of the fishway location and type was deduced in a similar manner, through researching requirements of the target species (alewife) and appropriate conditions for certain types.

It was concluded that an overflow spillway spanning 100 feet with an incorporated Denil fishway would be optimal for the site.

Analysis in the Hydrology of the area was conducted first, to determine the PMF flow that would have to be designed for in the structural analysis for public safety factors. The hydrologic study took into account factors such as the watershed basin area and soil characteristics of the watershed to determine runoff volumes and flooding potential. This value was also used through the Hydraulic analysis to find the velocities and depths of water around the dam under PMF conditions. The value applied though Hydraulic and Structural analysis was 8000 cfs. Hydrologic analysis data can be found in detail in Appendices A and B.

A different hydrologic approach was used to find the design flows for the fishway. This approach involved statistical analysis of the flow rates during only the migration period of alewife. Low, average, and high flows were determined to be 15 cfs, 140 cfs, and 350 cfs, respectively. A similar approach was used in combination with the PMF value to determine normal operating conditions of the dam structure. Annual estimates of low, average, and high flows were made to estimate these conditions that can be observed more often at the dam structure. These low, average, and high operating flows were determined to be 10 cfs, 100 cfs, and 2000 cfs. It should be noted that 4 flows were taken under consideration in the Hydraulic analysis. Based on this analysis, the optimal height of the dam was determined to be 3.5 feet, and the fishway would measure 4 feet wide, and be set into the dam structure 1.5 feet. Hydraulic data can be found in Appendix C.

Through the Structural Analysis, all of the loads and forces acting on the structure were found, which were used to determine the sliding and overturning stability of the structure. The reinforcement needed to support shear forces in the structural was also designed.

As a final design, the proposed structure consists of 3.5 feet high concrete gravity dam, with an overflow spillway with 0.85 slope. The concrete used to construct the structure should be normal weight concrete, with a strength of 3500 psi and a density of 150 lbs/cf.

The stability of the structure depends on the maximum upstream and downstream hydrostatic loads of 1037 lb/ft and 1062 lb/ft, respectively. The water velocity difference between upstream and downstream of 34 ft/s, and a ground acceleration of 0.1 times the three foot base of the structure. If, however, these values are altered, the stability of the structure may not meet the factor of safety required by ACI 350, Environmental Structure Engineering, of 2.0.

The structure proposed would have to include No. 4 vertical Grade 60 bars spaced at 18 inches on center and No. 4 horizontal Grade 60 bars spaced at 12 inches on center for the shear reinforcement of the structure. These values also meet the minimum crack reinforcement of No. 6 Grade 60 bars spaced at 12 inches on center, as stated in ACI 350. It is also recommended that one No. 5 Grade 60 vertical bar to be added at each end of the structure.

The structure is proposed to be supported by an impervious foundation to avoid the forces caused by underseepage under the structure. The type of foundation was also determined based on the size, type, weight of the structure, and loads supported by it.

This project also included the implementation of a fish passage to the site. For the analysis of the structure, the target species were essential to find the type and dimensions of the structure. For this structure, it is proposed that concrete Denil fish ladder 5 feet high, with a pool depth of 3 feet inside the channel for the fish passage. These dimensions also depended on the maximum and low flows found through the hydrologic analysis. The fish ladder was also determined to be stable, and it must include a total reinforcement area of 1.7 in<sup>2</sup> of steel, 0.7 in<sup>2</sup> of steel in each wall and 0.3 in<sup>2</sup> of steel at the bottom section of the channel.

The durability and service life of the concrete depends on the concrete mix design, which includes aggregate type, proportions, mix, place, and cure. After the aggregate and the proportions are designed, they should be mixed thoroughly, transported and placed without segregation, and cured to minimize cracking and optimize long term strength and durability of the concrete. The environmental conditions of the site that the concrete will be used are also important. For example, exposure to freezing, thawing, sulfates, acids, and variation of moisture should also be considered in the mix design. The service life of the concrete used in the structure depends majorly on these design elements, which were not within the scope of this design. However, the strength of the concrete under this design is considered to be 3500 psi.

Through the cost estimates, it was found that when the structures were built independently, the total cost was higher than if the structures were built at the same time. This increase in cost can be attributed to the repetition of some construction elements, such as site cleaning, dewatering, transportation of materials, renting facilities, and excavation. Built independently, the total cost would be \$293,086, while built together the cost would be \$206,559. The cost savings where the structures are built simultaneously is approximately \$90,000. Because of the large savings, it is recommended that the structures are built at the same time.

The following figures show the site plan including the proposed structures, cross section of the structures, and reinforcement for the dam structure. It should be noted that the fish ladder is located on the western side of the channel, as concrete connected to the dam.

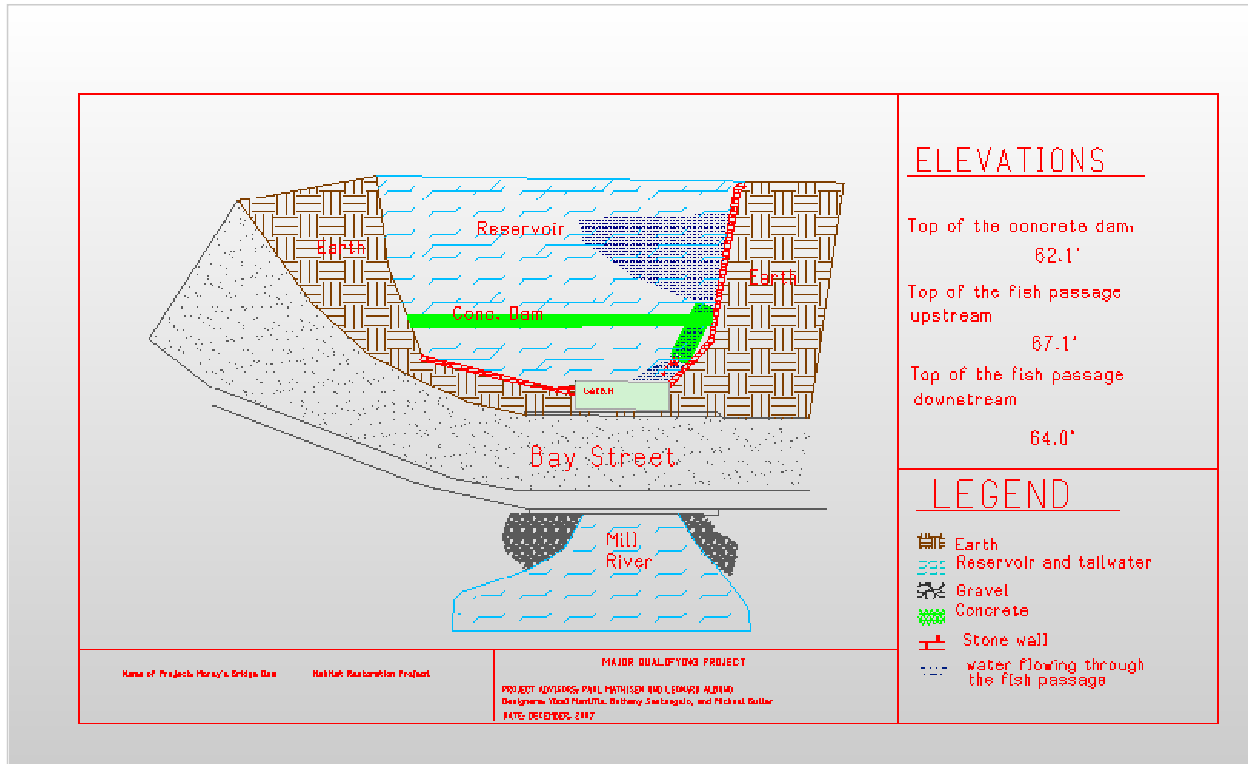

Figure 54. Proposed site plan.



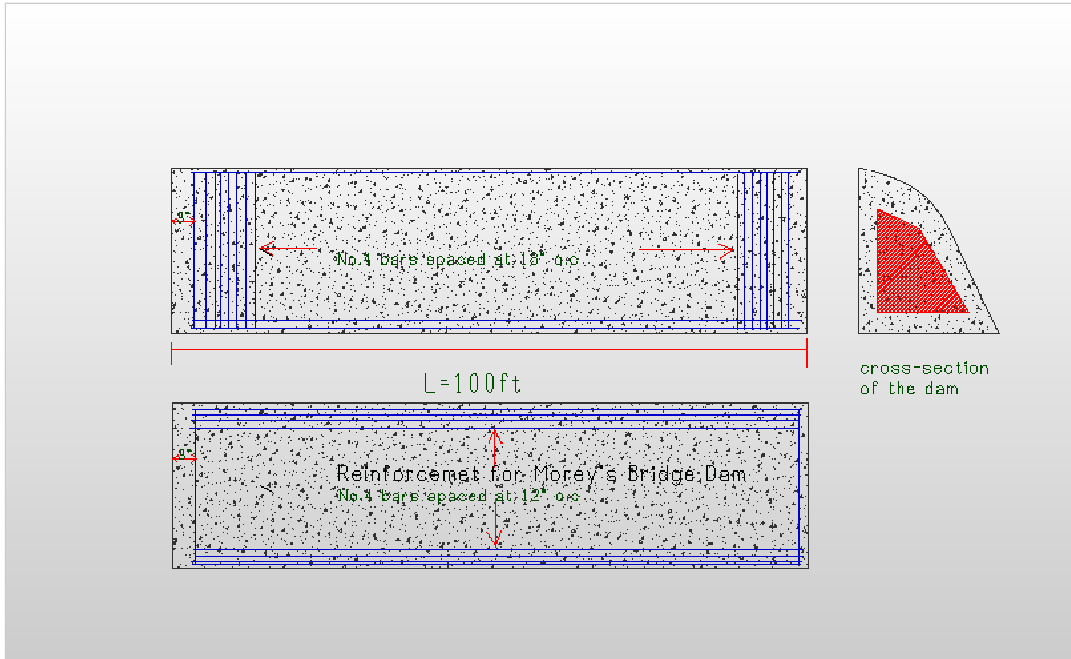

Figure 55. Dam reinforcement.

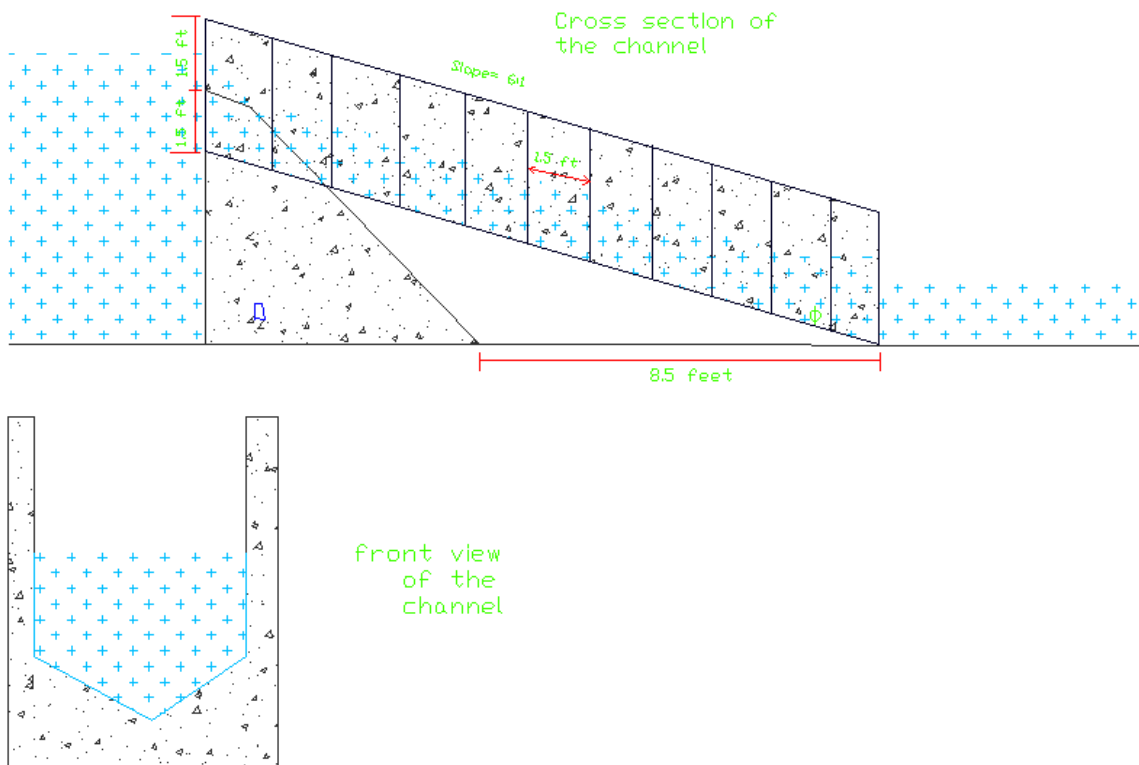

Figure 56. Fish ladder plan.

## 5 Conclusion & Recommendations

In summary, this project included the design of a small dam and Denil fish ladder to replace the deteriorating dam at Morey's Bridge Dam in Taunton, Massachusetts. The dam was designed through a hydrologic study of the area to estimate Probable Maximum Flood volumes that the dam would be exposed to, hydraulic analysis of the site to determine optimal dimensions of the dam and fishway, and structural analysis to determine public safety factors and structural stability.

The hydrology of the area was analyzed using techniques of the USACE HMR-51, HMR-52, and HEC-1 programs. These methods are iterative. Due to time constraints, the value expressed through the hydrologic analysis as the PMF is less than the value used in the hydraulic and structural analysis. The hydraulic and structural analysis were made based on preliminary hydrologic data, with a PMF equal to 8000 cfs. Considering that the final PMF value was 6200 cfs, this design is conservative.

The hydraulics of the site was analyzed using common hydraulic modeling techniques and equations. Principal factors in the fish passage design were adapted from presentations and information generously provided by Dick Quinn, a Hydraulic Engineer from the U.S. Fish and Wildlife Service.

The hydraulics analysis of the site concluded with calculated depths and velocities for the flows expected under low, average, normal, and PMF conditions. This led to the design of the dam structure to meet the sliding and overturning stability requirements. Since historical flow data for the site was limited, historical USGS flow data was used from an analogous river (Wading River) to estimate seasonal flows.

The constriction of the bridge abutments on the channel is of concern under PMF conditions. Despite efforts to design a dam structure that meet public safety requirements, the current condition of the bridge abutments suggest that they may not be structurally stable under PMF flows. Reconstruction of this bridge is beyond the scope of this project. However, upon reconstruction of this bridge, expansion of the bridge abutments should be considered to remove the constriction and expansion section of the channel. This would allow for greater flood protection and public safety in the area immediately downstream.

A key difference between suggested design techniques and the one used in this design is the orientation of the fishway channel. This channel could be termed a "straight shot", and under the spatial constraints presented by the landscape of the site, it seemed the best option. Other orientations for the fishway, relative to the channel, may be more effective in moving fish over the barrier. It is recommended that more flow measurements be made seasonally at the site for more accurate modeling. In addition to more frequent flow measurements, more accurate seasonal channel dimensions would be beneficial in producing a more accurate model.

Time was a significant constraint in this design. The constraints for the hydraulic design of the dam's spillway and fish passage, such as time and limited flow data, influenced the structural design of the structures, since this design was based on the results obtained in the hydraulic design. Detailed gauging data and revisitation of the hydraulic parts of this analysis may yield

more accurate results for the site at hand. At the very least, more detailed streamflow data from the project site would reinforce the conclusions of the hydraulic analysis. In particular, revisitation of the hydraulic analysis utilizing a hydraulic modeling program would improve the accuracy of tailwater depth calculations. As the tailwater channel was modeled as a straight, uniform channel in this analysis, modeling the channel with more detailed characteristics of elevations, channel path, and floodplain areas would improve the accuracy of predicted water depths at design flows. Physical modeling of the fishway is always the most accurate way to test the design, so it would be beneficial to create a physical model of this passage to insure effective passing of native alewife.

The goals expressed in the scope of this project were reached. The dam and fishway structures were designed following Capstone Design guidelines to meet the needs of the community and the target species. A cost evaluation was also completed to conclude that there is a significant financial benefit in constructing both the dam and fishway structures at the same time.

## Works Cited

- A. Osman Akan, Robert J. Houghtalen. *Urban Hydrology, Hydraulics, and Stormwater Quality: Engineering Applications and Computer Modeling*. John Wiley and Sons, 2003.
- Alan A. Smith Inc. *Hydrological Theory*. 2007. <http://www.miduss.com/theory-Calculating-Effective-Rainfall-The-Green-Ampt-Method.htm> (accessed 12 18, 2008).
- ASCE. "Fishway design ." *The Journal of Hydraulic Engineering*, 2003.
- Association of Dam Safety Officials. *Association of State Dam Safety Officials*. 2007. <http://www.damsafety.org/map/state.aspx?s=21> (accessed December 18, 2007).
- Bigelow, Henry B., and William C. Schroeder. "Alewife." *Fishes of the Gulf of Maine*. 2002. [http://www.gma.org/fogm/Pomolobus\\_pseudoharengus.htm](http://www.gma.org/fogm/Pomolobus_pseudoharengus.htm) (accessed October 30, 2007).
- Calvert, J. B. *Open Channel Flow*. June 6, 2007. <http://mysite.du.edu/~etuttle/tech/opench.htm> (accessed September 30, 2007).
- Castro-Santos, Theodore. "Optimal swim speeds for traversing velocity barriers: an analysis of volitional high-speed swimming behavior of migratory fishes." *Journal of Experimental Biology* (The Company of Biologists), 2005: 421-432.
- Chow, Ven Te. *Open Channel Hydraulics*. York, PA: McGraw-Hill, Inc., 1959.
- Engineers, Army Corps of. *Gravity Dams*. Army Corps of Engineers, 2002.
- Foronda, Erna. "Archived Hydraulic Engineering Topics." *Flood Control Division Resources and Management Department, Oroange County, California*. 2004. <http://www.ocflood.com/> (accessed November 11, 2007).
- Gilbert, R.I. "Shrinkage, cracking and deflection- serviceability of concrete structures." *Electronic Journal of Structural Engineering*, 2001.
- Haro, Alex, Theodore Castro-Santos, John Noreika, and Mufeed Odeh. "Swimming performance of upstream migrant fishes in open-channel flow: a new approach to predicting passage through velocity barriers." *Canadian Journal of Fisheries and Aquatic Science* (NRC Canada), 2004: 1590-1601.
- Hotchkiss, Rollin H., Eric R. Rowland, and Michael E. Barber. *Modeling Hydrology for Fish Passage*. Research Report, Pullman, WA: Washington State University, 2002.
- Hwang, Ned H. C. *Fundamentals of Hydraulic Engineering Systems*. Englewood Cliffs, NJ: Prentice Hall, 1989.
- . *Fundamentals of Hydraulic Engineering Systems*. Englewood Cliffs, NJ: Prentice Hall, 1996.
- Institute, American Concrete. "ACI Manual of Concrete Practice 2005." Part1, Part 3, Part4. Farmington Hills, MI: Rebecca A. Hartford.
- Janes, La Londe and. *Concrete Engineering Handbook*. New York: McGraw-Hill, Inc, 1961.
- Lotfi, Vahid. "seismic analysis of concrete gravity dams by decoupled modal approach in time domain." *Electronic Journal of Structural Engineering*, 2003.

MacGregor, James G. *Reinforced Concrete Mechanics and Design*. Upper Saddle River: Pearson Education, Inc, 2005.

Maggenti, Ric. "Mass Concrete Report." 2001.

Maine Department of Transportation. *Fish Passage Policy and Design Guide*. Design Guide, Augusta, ME: Maine Department of Transportation, 2004.

Maryland Department of Natural Resources. *Maryland's Rivers and Streams Fish Passage*. April 7, 2007. [http://www.dnr.state.md.us/streams/freshwater\\_fisheries.html](http://www.dnr.state.md.us/streams/freshwater_fisheries.html) (accessed December 10, 2007).

Massachusetts Department of Fish and Wildlife. *Riverways Program: Program and Projects*. April 2007. <http://www.mass.gov/dfwele/river/programs/priorityprojects/millriver.htm> (accessed August 30, 2007).

Massachusetts Geographical Information System. *The Commonwealth's Office of Geographical and Environmental Information*. 12 18, 2007. <http://www.mass.gov/mgis/> (accessed 12 18, 2008).

Microsoft Encarta. *Concrete Gravity Dam*. 2007. [http://encarta.msn.com/media\\_461551342/Concrete\\_Gravity\\_Dam.html](http://encarta.msn.com/media_461551342/Concrete_Gravity_Dam.html) (accessed January 9, 2008).

Mikhelson, Ilya. *Structural Engineering formulas*. New York: RR Donnelley, 2004.

National Resource Conservation Service . "NRCS." *National Engineering Handbook Section 4: Hydrology*. 2004. <http://www.info.usda.gov/CED/Default.cfm?xSbj=59&xAud=24> (accessed 12 18, 2008).

Ned H. C. Hwang, Robert J. Houghtalen. *Hwang's Fundamentals of Hydraulic Engineering Systems*. Third Edition. Prentice Hall, 1996.

Odeh, Mufeed. "discharge Rating equation and Hydraulic Characteristics of standard denil fishways." *Journal of Hydraulic Engineering*, 2003.

Odeh, Mufeed. "Discharge Rating Equation and Hydraulic Characteristics of Standard Denil Fishways." *Journal of Hydraulic Engineering* 129, no. 5 (May 2003): 341-348.

Pare Corporation. "Morey's Bridge Dam Temporary Cofferdam." May 2007.

Pippard, Alfred John Sutton. *The analysis of engineering structures*. New York: Longmans, Green and Co, 1936.

Plizzari, Giovanni. "Centrifuge Modeling and Analysis of Concrete Gravity Dams." *Journal of Structural Engineering*, 1995: 1471-1479.

Purdue University Research Foundation. "SCS Curve Number Method." 2004. <http://www.ecn.purdue.edu/runoff/documentation/scs.htm> (accessed 12 16, 2008).

Quinn, Dick. *Intro to Fishway Design -Denil Fishways (.ppt presentation)*. February 16, 2007.

Quinn, Dick. *Intro to Fishway Hydrology & Hydraulics -FERC Fish Passage Training Course*. January 25, 2007.

- Reclamation, United States Bureau of. *Design of small dams*. Washington, 1977.
- Shaw, Elizabeth M. *Hydrology in Practice*. Taylor & Francis, 1994.
- Sturm, Terry W. *Open Channel Hydraulics*. New York, NY: McGraw-Hill Companies, Inc., 2001.
- Texas University Research Foundation. *Subbasin Loss Methods*. 2001.  
<http://www.ce.utexas.edu/prof/maidment/gradhydro2001/soilwater/HMS.ppt>. (accessed 12 18, 2008).
- The World Almanac. *Annual Rainfall for U.S. States*. 1988.
- United States Army Corp of Engineers. *Stability Analysis of Concrete Structures*. December 1, 2005. <http://www.usace.army.mil/publications/eng-manuals/em1110-2-2100/toc.htm> (accessed January 9, 2008).
- United States Army Corps of Engineers. "EM 1110-2-1601 (1 July 1991/30 June 1994)." *United States Army Corps of Engineers Engineer Manuals*. June 30, 1994.  
<http://www.usace.army.mil/publications> (accessed October 8, 2007).
- . "Hydrologic Engineering Center." *Hydrologic Engineering Center*. 2006.  
<http://www.hec.usace.army.mil/> (accessed 12 16, 2008).
- United States Environmental Protection Agency. *Water Resources*. December 20, 2007.  
<http://www.epa.gov/climatechange/effects/water/cycle.html> (accessed January 9, 2008).
- United States Geologic Survey (USGS). *USGS Real-Time Data for Massachusetts\_ Streamflow*. September 27, 2007. <http://waterdata.usgs.gov/ma/nwis/current?> (accessed September 27, 2007).
- Walters, Rupert Cavendish Skyring. *Dam Geology*. London: Butterworths, 1962.

# Appendix A. Hydrologic Analysis.

**USGS**
National Water Information System: Web Interface

---

Water Resources

News: [Available Now in NWISWeb](#)

## USGS 01108410 MILL RIVER AT SPRING STREET AT TAUNTON, MA

### PROVISIONAL DATA SUBJECT TO REVISION

Available data for this site
Time-series: Real-time data
GO

**LOCATION** --Lat 41°53'59", long 71°05'24", Bristol County, Hydrologic Unit 01090004, on left bank, 20 ft upstream from Spring Street bridge in Taunton, and about 0.8 mi upstream from mouth at Taunton River.  
**DRAINAGE AREA** --43.5 mi<sup>2</sup>.  
**PERIOD OF RECORD** --Discharge: December 2005 to current year.  
**GAGE** --Water-stage recorder with satellite telemeter. Datum of gage is 15 ft above National Geodetic Vertical Datum of 1929, from topographic map.  
**REMARKS** --Flow may be regulated at times from upstream ponds and dams. Stage and discharge records may be affected by daily or more frequent backwater from tide. Periods of tidal influence are removed from the recorded data prior to the computation of daily mean discharge.  
**COOPERATION BY:** [City of Taunton](#).

Available Parameters	Output format	Days
<input type="checkbox"/> All 2 Available Parameters for this site	<input checked="" type="radio"/> Graph	7
<input checked="" type="checkbox"/> 00065 Gage height	<input type="radio"/> Graph w/ stats	(1-31)
<input checked="" type="checkbox"/> 00060 Discharge	<input type="radio"/> Graph w/o stats	<input type="button" value="GO"/>
	<input type="radio"/> Table	
	<input type="radio"/> Tab-separated	

[Summary of additional data for this site](#)

**Gage height, feet**  
 Most recent instantaneous value: 3.19 12-09-2007 21:00

USGS 01108410 MILL RIVER AT SPRING STREET AT TAUNTON, MA

----- Provisional Data Subject to Revision -----

Parameter 00065; DD 01

[Create presentation-quality graph](#)

**Discharge, cubic feet per second**  
 Most recent instantaneous value: 15 12-09-2007 21:00

USGS 01108410 MILL RIVER AT SPRING STREET AT TAUNTON, MA

----- Provisional Data Subject to Revision -----

Parameter 00060; DD 02

[Create presentation-quality graph](#)

Figure 57. CURRENT USGS DATA REGARDING THE MILL RIVER AND ITS WATERSHED

Table 21. ARBITRARY COORDINATES FOR OUTLINE OF MILL RIVER WATERSHED

x	y
5.4	17.5
7.4	17.9
7.8	16.9
8.6	14.8
9.2	14.2
9.5	13.2
9.6	11.8
10.7	9.7
10.3	9.4
11.8	7.2
11.7	6.5
11.3	4.4
11	3.3
11.8	2.4
9.9	2
9.5	2.8
9.9	4
9.7	5.7
8.9	6.9
7.6	8.3

Basin Area = 44.8 Square Miles

Centroid Coordinates = (8.4, 10.7)



7.2	9.2
6.6	10.5
5.8	12.1
5.7	13.2
4.9	14.5
5.6	17.1

# Land Usage Within Mill River Watershed

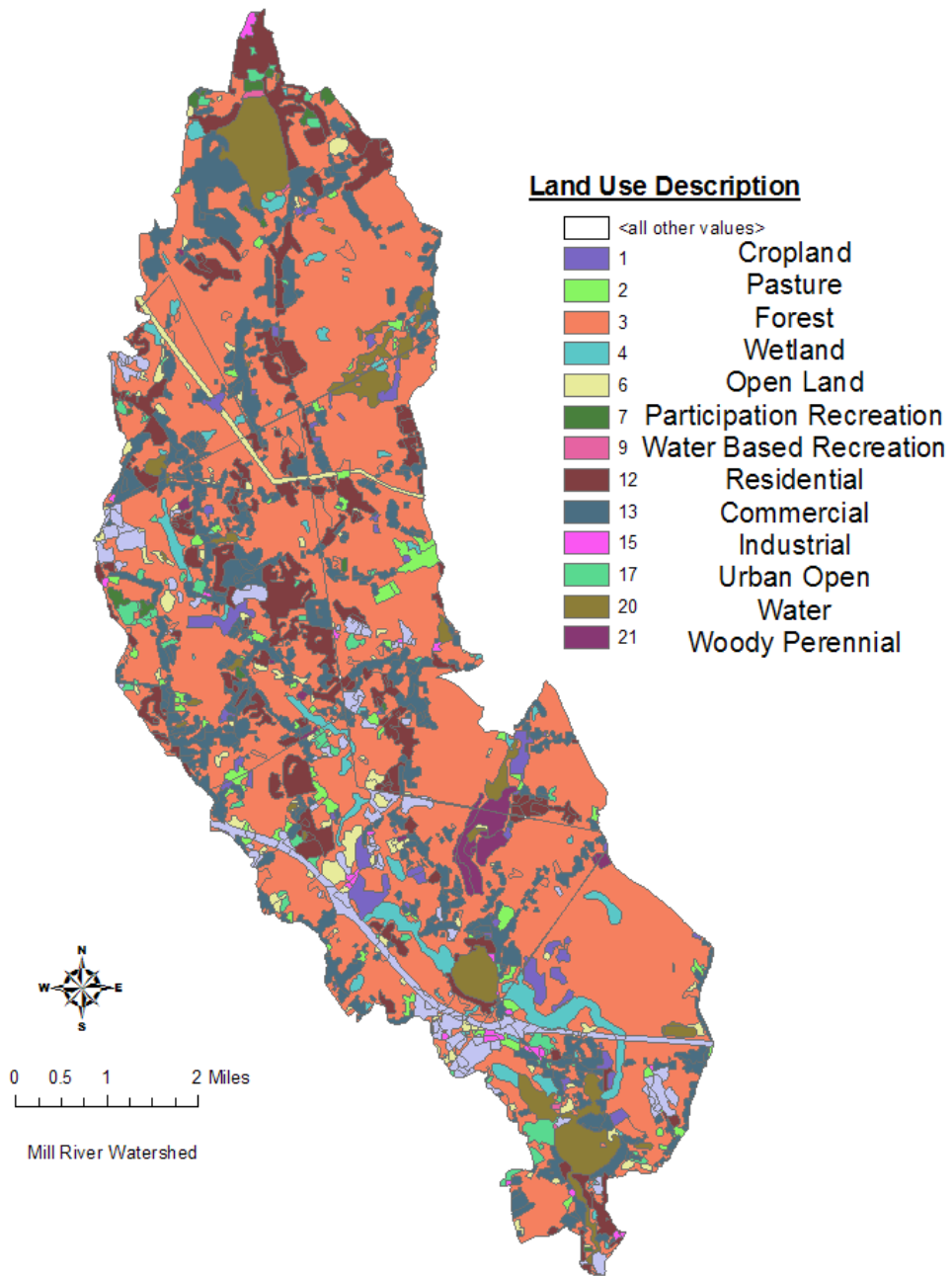

Figure 58. Land usage within the Mill River Watershed.

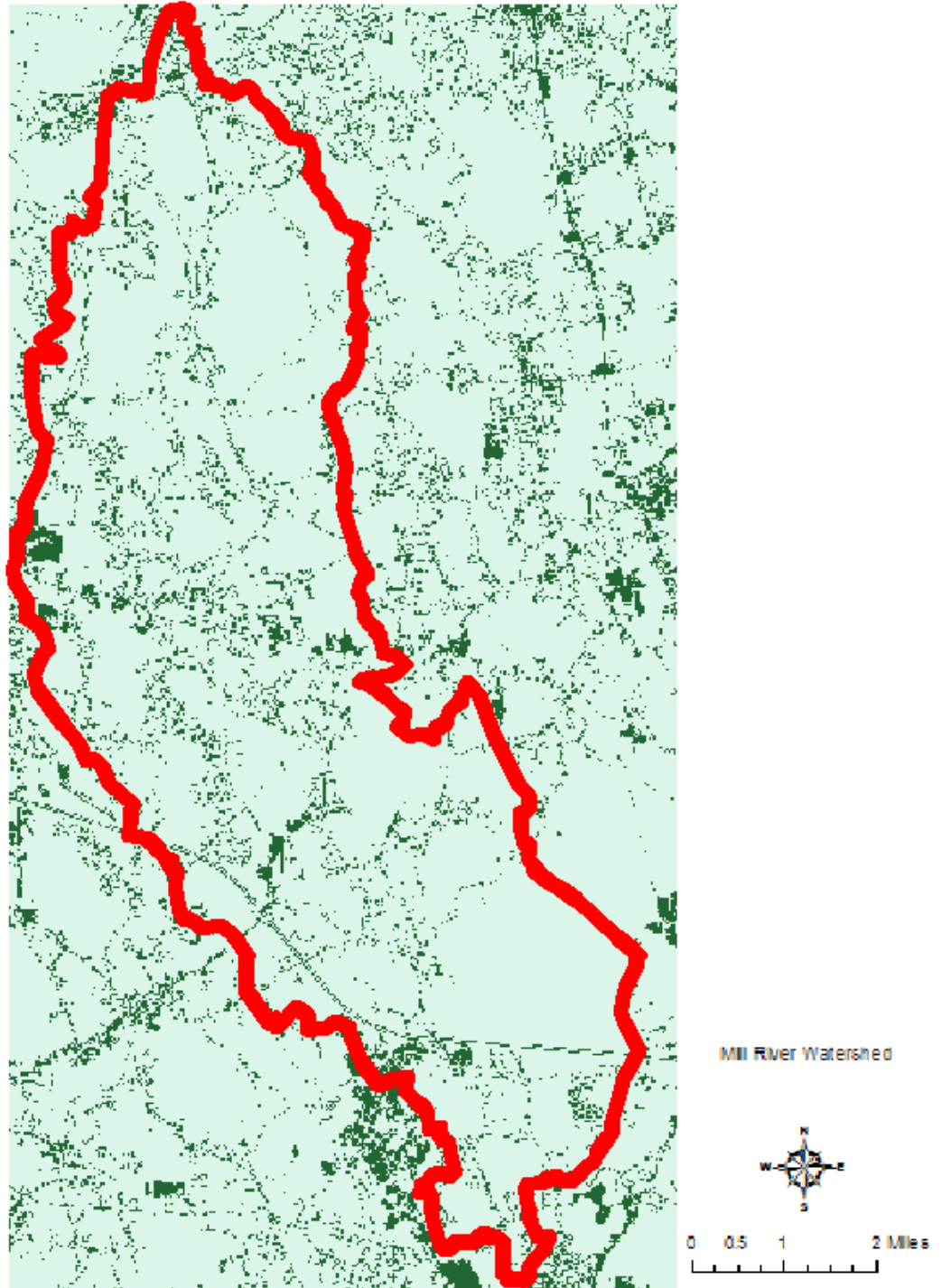

Figure 59. Impervious Area within Mill River Watershed

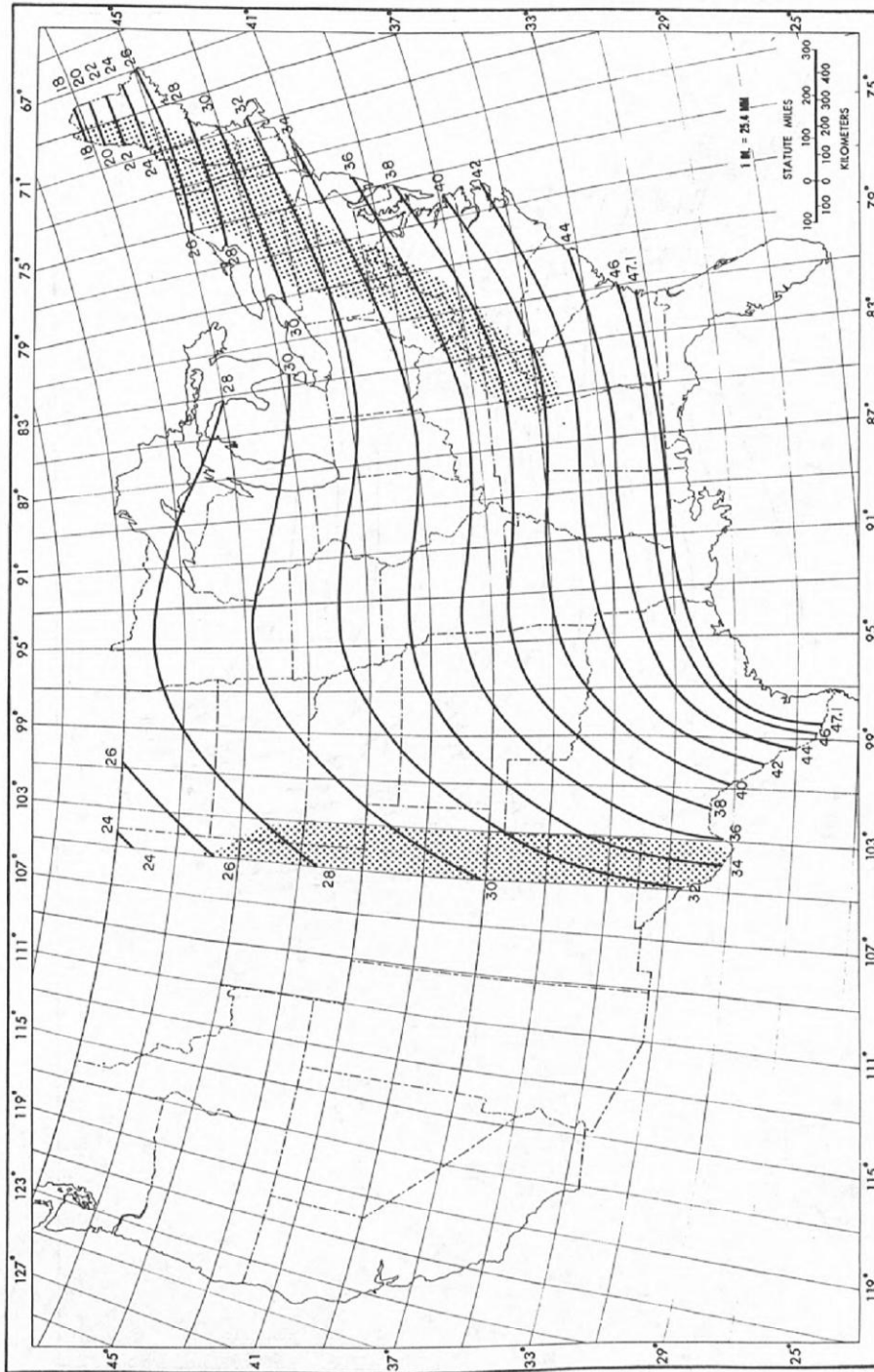

Figure 20. ---All-season PMP (in.) for 24 hr 10 mi<sup>2</sup> (26 km<sup>2</sup>).

Figure 60. HMR-51 ISOPLUVIAL MAP (COMPLETE FIGURES PROVIDED IN DATA FILES)

The Hydrologic Engineering Center

10 February 1988

INSTALLATION INSTRUCTIONS OR  
MICROCOMPUTER VERSION OF  
HMR52

This version of HMR52 (April 1987) will run  
on an IBM or

compatible microcomputer that has the  
following:

- \* 256 Kilobytes (KB) of Random Access  
Memory (RAM)
- \* MS DOS 2.1 or greater
- \* One 5 1/4 inch floppy diskette drive (360  
KB or 1.2 MB)
- \* A 10 Megabyte (or larger) hard disk is  
recommended
- \* A math coprocessor (8087, 80287, or  
80387) is highly  
recommended, but not required. The math  
coprocessor  
will greatly reduce the execution time of  
the program  
(increases computational speed by a factor  
of 5 to 10).

I. PROGRAM INSTALLATION

A. Contents of the HMR52 Diskette

The HMR52 computer program, example  
input data, and

example output are provided on a 5 1/4  
inch double-

sided 360 KB floppy diskette as follows:

HMR52 DISKETTE: HMR52.EXE

JONES.DAT

LEON.DAT

HMR52T.DAT

WASH.DAT

JONES.OUT

LEON.OUT

WASH.OUT

README.DOC

Explanation of Files Included on the HMR52  
Package

Diskette

HMR52.EXE: The HMR52 program in an  
executable form.

HMR52T.DAT: HMR52 table file, which  
contains Hydromet Report No. 51  
in tabular form (this is  
necessary for execution of the  
program).

JONES.DAT: HMR52 example input data.

LEON.DAT: HMR52 example input data.

WASH.DAT: HMR52 example input data.

JONES.OUT: example output file for  
JONES.DAT.

LEON.OUT: example output file for  
LEON.DAT.

WASH.OUT: example output file for

WASH.DAT.

README.DOC: file containing this implementation guide.

#### B. Installation on a Hard Disk System

The following set of instructions will allow the user to run the HMR52 program from any of the user's data directories.

1. You will need to create three directories. One

of the directories should be labeled \HECEXE.

This directory will be used to store all of the HEC executable programs. A second directory

should be labeled \HECEXE\SUP. This directory

will be used to store all of the supplemental files required by the executable programs. A

third directory should be created to store data

files. This dat directory can be given any name. You may want this data directory to represent a specific project, person, or program. For this example, let's assume that

you are going to label the data directory \HMR52. To accomplish these tasks do the following:

\* Go to the drive (e.g. C:) in which you would like to install the software.

\* Type MD\HMR52 then press the <ENTER> key.

\* Type MD\HECEXE then press the <ENTER> key.

\* Type MD\HECEXE\SUP then press the <ENTER>

key.

2. Place the HMR52 diskette into the A drive.

3. The next step will be to copy the HMR52 input

and output files. If you do not want these files copied to your hard disk, go to step 4.

If you would like these files copied to your hard disk, do the following:

\* Type CD HMR52 then press the <ENTER> key.

\* Type COPY A:\*.DAT C: then press the <ENTER>

key.

\* Type COPY A:\*.OUT C: then press the <ENTER>

key.

4. The next step will be to copy the HMR52 program. The file is named HMR52.EXE. Use the

following commands to do so:

\* Type CD \HECEXE then press the <ENTER> key.

\* Type COPY A:\*.EXE C: then press the <ENTER>

key.

\* Type CD \ then press the <ENTER> key.

5. To allow access of the executable programs from

any directory, it will be necessary to edit the

AUTOEXEC.BAT file to include a path to the \HECEXE directory. The AUTOEXEC.BAT file should be in your root (C:\) directory. The following is an example PATH command that would

allow access to the \HECEXE directory as well

as the root (C:\) directory:

```
PATH C:\;C:\HECEXE
```

-- You may want to include a path to other directories on your system. If so, just add the names of the directories to this command.

For more information on the PATH command and

the AUTOEXEC.BAT file, consult your DOS manual.

6. The final step will be to modify your CONFIG.SYS file. Many HEC programs require the capability to open more than eight (8) files at any one time. Because eight is the system default, you will need to modify your CONFIG.SYS file to include the following two lines:

```
FILES=20
```

```
BUFFERS=20
```

For more information concerning the CONFIG.SYS

file, consult your DOS manual.

### C. Installation on a Two-Floppy-Diskette System

There is no installation for a two-floppy diskette system.

## II. PROGRAM EXECUTION

A. To run HMR52 from the hard disk do the following

commands:

\* Go to the directory in which your data are stored (e.g. \HMR52).

\* Type HMR52 then press the <ENTER> key. The

program then will prompt you for input filename, output filename, etc.

OR

\* Type HMR52 INPUT=filename OUTPUT=filename then

press the <ENTER> key; where:

INPUT=filename: the filename where the HMR52 input data resides.

OUTPUT=filename: the filename where the output data will be written. If the user wishes the output to go directly to the screen or printer, the commands CON (screen)

or LPT1 (printer) can be used in place of the output filename.

B. To run HMR52 from a floppy diskette do the following commands:

\* Place the diskette containing the HMR52 program

on it in drive A

\* Type A:HMR52 then press the <ENTER> key. The

program then will prompt you for input filename, output filename, etc.

OR

\* Type HMR52 INPUT=filename OUTPUT=filename then

press the <ENTER> key; where:

INPUT=filename: the filename where the HMR52 input data resides.

OUTPUT=filename: the filename where the output data will be

written. If the user wishes the output to

go directly to the screen or printer, the

commands CON (screen)

or LPT1 (printer) can

be used in place of

the output filename.

### III. PROGRAM VERIFICATION

Using the above example, you can execute the HMR52

program by using one of the example data files

provided to you. At this point you should compare

your output file (HMR52.ANS, for example) with the one

provided to you (LEON.OUT, JONES.OUT, WASH.OUT).

Comparing the two output files can be accomplished by

using the DOS compare command (COMP). Check your

results to insure that they are the same, except for

execution date and time, as to what we provided to

you. This will insure that the program is working

correctly on your computer system.

### IV. PROGRAM PROBLEMS

If any errors are encountered which indicate potential

problems in this HMR52 package, please contact the

HEC.

U.S. Army Corps of Engineers

The Hydrologic Engineering Center

609 Second Street

Davis, CA 95616

USA

(916) 551-1748



```

1*****
*****
*
*          *          *          *
*  PROBABLE MAXIMUM STORM (HMR52) *          *  U.S. ARMY
CORPS OF ENGINEERS *
*    NOVEMBER 1982      *          *  THE HYDROLOGIC
ENGINEERING CENTER *
*    REVISED APRIL 91   *          *  609 SECOND STREET      *
*          *          *          *  DAVIS, CALIFORNIA 95616   *
* RUN DATE 10/04/2007  TIME 16:44:41 *          *  (916) 551-1748 OR
(FTS) 460-1748 *
*          *          *          *
*****
*****

```

```

H H M M RRRRRR 555555 22222
H H MM MM R R 5 2 2
H H MMMM R R 5 2
HHHHHHH M M M RRRRRR 55555 2
H H M M R R 5 2
H H M M R R 5 5 2
H H M M R R 55555 2222222

```

1 HEC PROBABLE MAXIMUM STORM (HMR52) INPUT DATA  
PAGE 1

LINE	ID.....1.....2.....3.....4.....5.....6.....7.....8.....9.....10
1	ID HMR52 INPUT DATA FOR butler PMF CALCULATION
2	BN TOTAL
3	BS 1
4	BX 5.44 7.43 7.80 8.55 9.20 9.49 9.57 10.66 10.31 11.76

5 BX 11.68 11.31 11.04 11.78 9.92 9.49 9.92 9.72 8.90 7.63  
 6 BX 7.16 6.56 5.77 5.74 4.92 5.57  
 7 BY 17.55 17.90 16.88 14.79 14.22 13.20 11.78 9.72 9.35 7.18  
 8 BY 6.49 4.40 3.26 2.36 1.99 2.76 3.98 5.72 6.93 8.25  
 9 BY 9.20 10.46 12.13 13.17 14.54 17.10  
 10 PL 2  
 11 ID Hydrogeologic Data From HMR-51  
 12 HO 208  
 13 HP 10 25 29 32 36 38  
 14 HP 200 17.0 20.5 23.5 27.0 28.2  
 15 HP 1000 12.0 15.5 19.5 23.0 23.5  
 16 HP 5000 7.5 11.0 14.0 17.5 18.5  
 17 HP 10000 5.8 9.1 12.0 15.0 16.1  
 18 HP 20000 4.2 7.2 9.9 13.1 14.1  
 19 ID Storm Specifications  
 20 SA 20.31 0  
 21 ST 360 .3  
 22 ZZ

1\*\*\*\*\*  
 \*\*\*\*\*

\* \* \* \* \*  
 \* PROBABLE MAXIMUM STORM (HMR52) \* \* U.S. ARMY  
 CORPS OF ENGINEERS \*  
 \* NOVEMBER 1982 \* \* THE HYDROLOGIC  
 ENGINEERING CENTER \*  
 \* REVISED APRIL 91 \* \* 609 SECOND STREET \*  
 \* \* \* \* \* DAVIS, CALIFORNIA 95616 \*  
 \* RUN DATE 10/04/2007 TIME 16:44:41 \* \* (916) 551-1748 OR  
 (FTS) 460-1748 \*  
 \* \* \* \* \*

\*\*\*\*\*  
 \*\*\*\*\*

HMR52 INPUT DATA FOR butler PMF CALCULATION

Hydrogeologic Data From HMR-51

Storm Specifications

PMP DEPTHS FROM HMR 51

AREA (SQ. MI.)	DURATION				
	6-HR	12-HR	24-HR	48-HR	72-HR
10.	25.00	29.00	32.00	36.00	38.00
200.	17.00	20.50	23.50	27.00	28.20
1000.	12.00	15.50	19.50	23.00	23.50
5000.	7.50	11.00	14.00	17.50	18.50
10000.	5.80	9.10	12.00	15.00	16.10
20000.	4.20	7.20	9.90	13.10	14.10

STORM AREA	PMP DEPTHS FOR 6-HOUR INCREMENTS											
	25.02	3.68	2.12	1.49	1.16	.94	.80	.69	.61	.54	.49	.45
10.	25.02	3.68	2.12	1.49	1.16	.94	.80	.69	.61	.54	.49	.45
25.	23.13	3.63	2.06	1.45	1.12	.91	.77	.66	.58	.52	.47	.43
50.	21.56	3.61	2.02	1.41	1.08	.88	.74	.64	.56	.50	.45	.41
100.	19.25	3.57	1.95	1.35	1.03	.84	.70	.61	.53	.48	.43	.39
175.	17.39	3.52	1.89	1.30	1.00	.81	.68	.58	.51	.46	.41	.38
300.	15.66	3.65	1.91	1.31	.99	.80	.67	.58	.51	.45	.41	.37
450.	14.37	3.79	1.95	1.32	1.00	.80	.67	.58	.51	.45	.41	.37
700.	12.97	3.93	1.98	1.33	1.01	.81	.68	.58	.51	.45	.41	.37
1000.	11.84	4.05	2.01	1.34	1.01	.81	.68	.58	.51	.45	.41	.37
1500.	10.73	3.93	1.97	1.32	1.00	.80	.67	.58	.51	.45	.41	.37
2150.	9.74	3.83	1.94	1.31	.99	.79	.66	.57	.50	.45	.40	.37
3000.	8.84	3.71	1.91	1.29	.98	.79	.66	.57	.50	.44	.40	.36
4500.	7.73	3.59	1.87	1.27	.97	.78	.65	.56	.49	.44	.40	.36
6500.	6.79	3.49	1.81	1.23	.93	.75	.63	.54	.48	.42	.38	.35
10000.	5.74	3.39	1.73	1.17	.89	.71	.60	.51	.45	.40	.36	.33
15000.	4.80	3.19	1.70	1.16	.89	.72	.60	.52	.45	.40	.37	.33
20000.	4.14	3.05	1.67	1.16	.88	.72	.60	.52	.46	.41	.37	.34

BOUNDARY COORDINATES FOR TOTAL

X 5.4 7.4 7.8 8.6 9.2 9.5 9.6 10.7 10.3 11.8  
 Y 17.5 17.9 16.9 14.8 14.2 13.2 11.8 9.7 9.4 7.2

X 11.7 11.3 11.0 11.8 9.9 9.5 9.9 9.7 8.9 7.6  
 Y 6.5 4.4 3.3 2.4 2.0 2.8 4.0 5.7 6.9 8.3

X 7.2 6.6 5.8 5.7 4.9 5.6  
 Y 9.2 10.5 12.1 13.2 14.5 17.1

SCALE = 1.0000 MILES PER COORDINATE UNIT

BASIN AREA = 44.8 SQ. MI.

BASIN CENTROID COORDINATES, X = 8.4, Y = 10.7

PROBABLE MAXIMUM STORM FOR TOTAL

STORM AREA = 20. SQ. MI., ORIENTATION =\*\*\*\*\*, PREFERRED ORIENTATION = 208.

STORM CENTER COORDINATES, X = 8.4, Y = 10.7

AREA

ISOHYET WITHIN

AREA (SQ.MI.)	BASIN (SQ.MI.)	DEPTHS (INCHES) FOR 6-HOUR INCREMENTS OF PMS											
		1	2	3	4	5	6	7	8	9	10	11	12
A 10.	10.	23.93	3.73	2.09	1.46	1.13	.92	.77	.67	.59	.53	.48	.43
B 25.	17.	20.09	3.22	1.87	1.32	1.02	.83	.70	.60	.53	.48	.43	.39
C 50.	24.	14.58	2.39	1.41	.99	.76	.62	.52	.45	.40	.36	.32	.29
D 100.	33.	11.45	1.96	1.14	.80	.62	.50	.42	.37	.32	.29	.26	.24
E 175.	43.	9.33	1.58	.91	.64	.49	.40	.34	.29	.26	.23	.21	.19
F 300.	45.	7.48	1.27	.75	.52	.40	.33	.28	.24	.21	.19	.17	.16
G 450.	45.	6.06	1.07	.63	.44	.34	.28	.23	.20	.18	.16	.14	.13
H 700.	45.	4.78	.83	.49	.34	.26	.22	.18	.16	.14	.12	.11	.10

I 1000.	45.	3.60	.63	.39	.27	.21	.17	.14	.12	.11	.10	.09	.08
J 1500.	45.	2.42	.49	.30	.21	.16	.13	.11	.09	.08	.07	.07	.06
K 2150.	45.	1.38	.31	.19	.13	.10	.08	.07	.06	.05	.05	.04	.04
L 3000.	45.	.43	.11	.06	.03	.03	.02	.02	.02	.01	.01	.01	.01
M 4500.	45.	.00	.00	.00	.00	.00	.00	.00	.00	.00	.00	.00	.00
N 6500.	45.	.00	.00	.00	.00	.00	.00	.00	.00	.00	.00	.00	.00
O 10000.	45.	.00	.00	.00	.00	.00	.00	.00	.00	.00	.00	.00	.00
P 15000.	45.	.00	.00	.00	.00	.00	.00	.00	.00	.00	.00	.00	.00
Q 25000.	45.	.00	.00	.00	.00	.00	.00	.00	.00	.00	.00	.00	.00
R 40000.	45.	.00	.00	.00	.00	.00	.00	.00	.00	.00	.00	.00	.00
S 60000.	45.	.00	.00	.00	.00	.00	.00	.00	.00	.00	.00	.00	.00

AVERAGE DEPTH      16.68   2.69   1.55   1.09   .84   .68   .58   .50   .44   .39   .36   .32

PROBABLE MAXIMUM STORM (PMS) FOR TOTAL

DAY 1

TIME PRECIPITATION	TIME PRECIPITATION	TIME PRECIPITATION	TIME PRECIPITATION
INCR TOTAL	INCR TOTAL	INCR TOTAL	INCR TOTAL
0600 .32 .32	1200 .39 .72	1800 .50 1.22	2400 .68 1.90

DAY 2

TIME PRECIPITATION	TIME PRECIPITATION	TIME PRECIPITATION	TIME PRECIPITATION
INCR TOTAL	INCR TOTAL	INCR TOTAL	INCR TOTAL
0600 1.09 2.99	1200 2.69 5.69	1800 16.68 22.37	2400 1.55 23.91

DAY 3

TIME PRECIPITATION	TIME PRECIPITATION	TIME PRECIPITATION	TIME PRECIPITATION
PRECIPITATION	PRECIPITATION	PRECIPITATION	PRECIPITATION
INCR TOTAL	INCR TOTAL	INCR TOTAL	INCR TOTAL
0600 .84 24.75	1200 .58 25.33	1800 .44 25.77	2400 .36 26.1

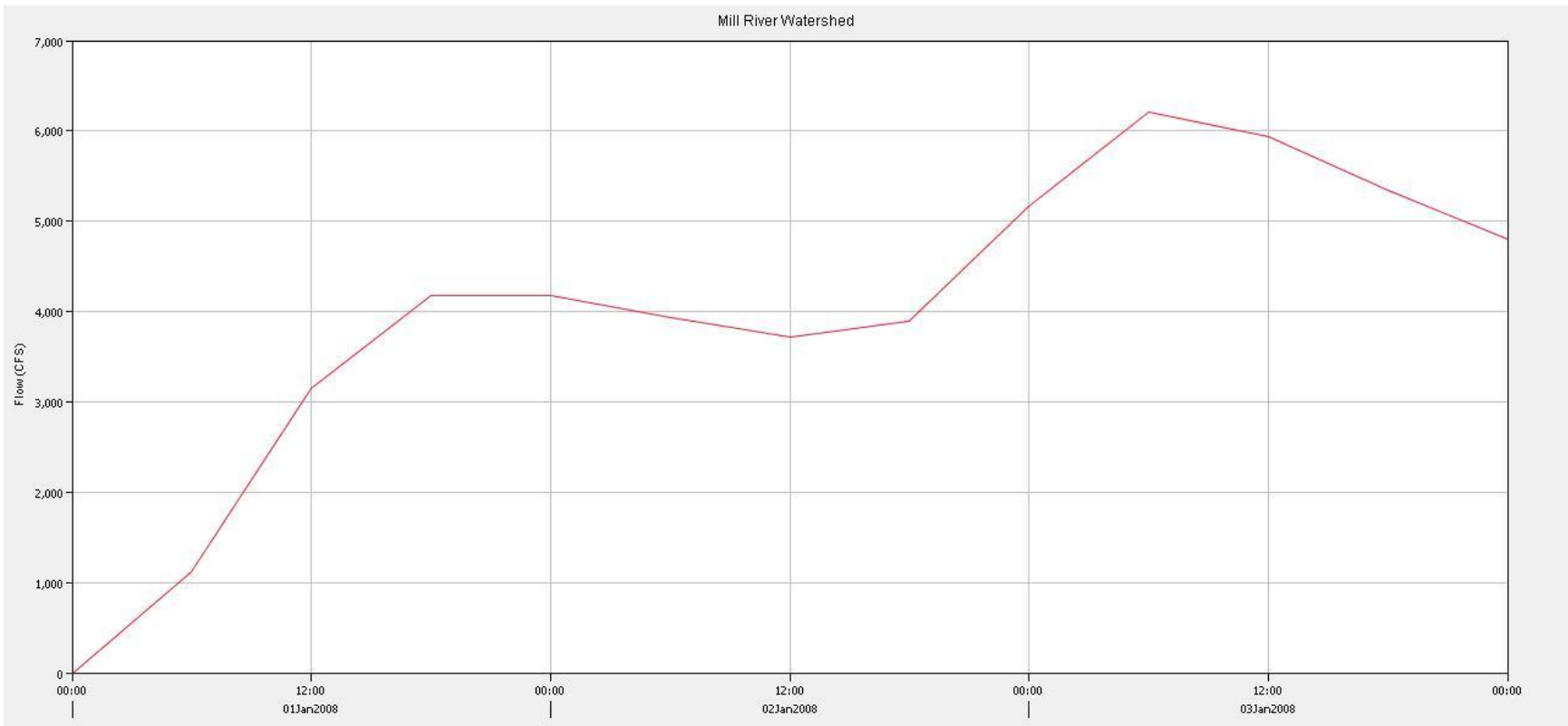

Figure 61. Mill River Watershed Runoff Hydrograph at Morey's Bridge Dam

## Appendix B. Fish Passage Hydrology

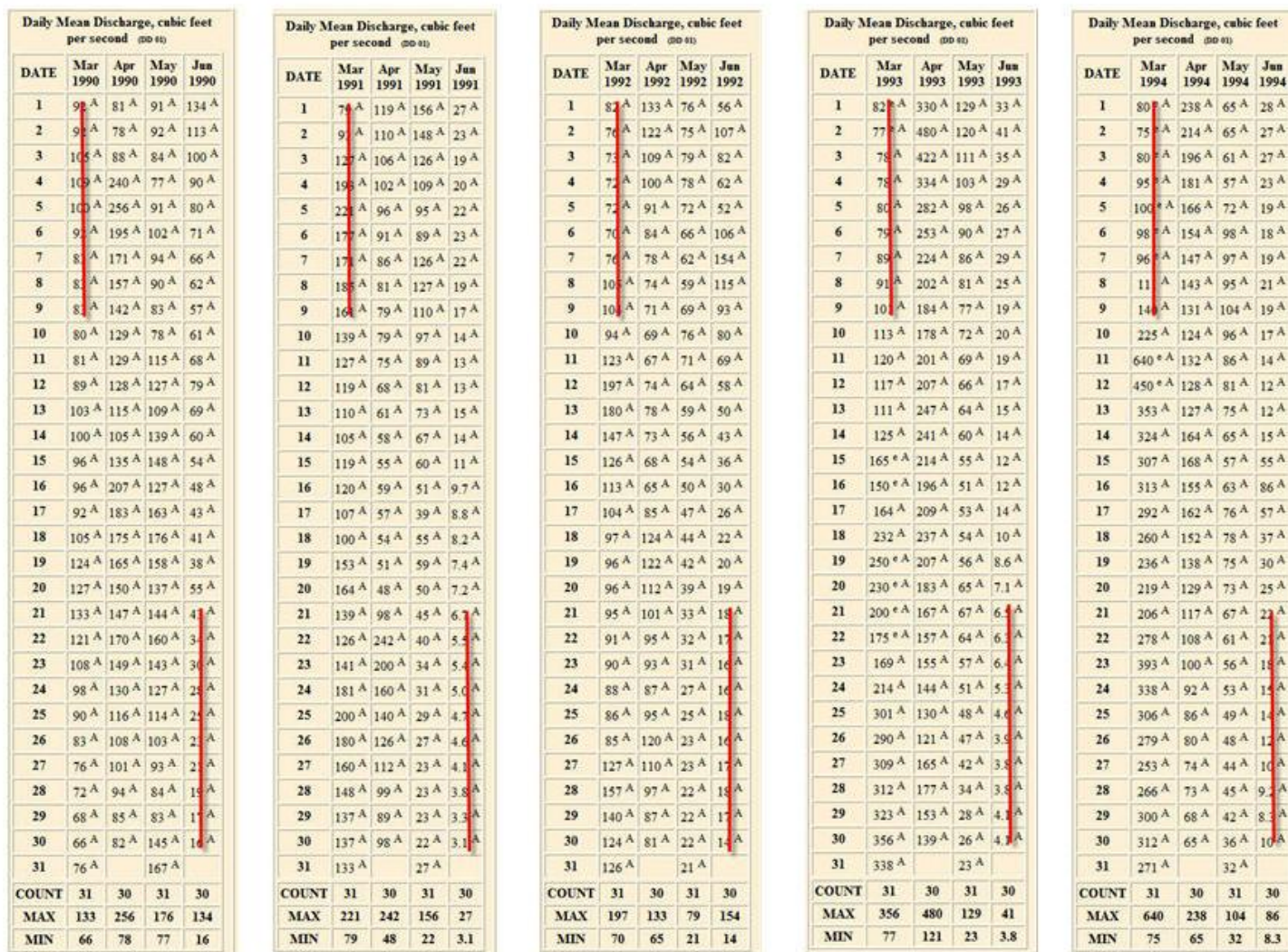

Figure 62. Historical Daily Means Data. (United States Geologic Survey (USGS) 2007)



Daily Mean Discharge, cubic feet per second (cfs)				
DATE	Mar 1995	Apr 1995	May 1995	Jun 1995
1	12 <sup>A</sup>	57 <sup>A</sup>	61 <sup>A</sup>	23 <sup>A</sup>
2	12 <sup>A</sup>	55 <sup>A</sup>	78 <sup>A</sup>	21 <sup>A</sup>
3	10 <sup>A</sup>	52 <sup>A</sup>	69 <sup>A</sup>	17 <sup>A</sup>
4	9 <sup>A</sup>	53 <sup>A</sup>	61 <sup>A</sup>	18 <sup>A</sup>
5	9 <sup>A</sup>	58 <sup>A</sup>	55 <sup>A</sup>	17 <sup>A</sup>
6	9 <sup>A</sup>	54 <sup>A</sup>	48 <sup>A</sup>	15 <sup>A</sup>
7	9 <sup>A</sup>	51 <sup>A</sup>	41 <sup>A</sup>	25 <sup>A</sup>
8	9 <sup>A</sup>	50 <sup>A</sup>	35 <sup>A</sup>	59 <sup>A</sup>
9	13 <sup>A</sup>	50 <sup>A</sup>	33 <sup>A</sup>	108 <sup>A</sup>
10	160 <sup>A</sup>	56 <sup>A</sup>	32 <sup>A</sup>	91 <sup>A</sup>
11	136 <sup>A</sup>	56 <sup>A</sup>	32 <sup>A</sup>	71 <sup>A</sup>
12	119 <sup>A</sup>	52 <sup>A</sup>	37 <sup>A</sup>	70 <sup>A</sup>
13	108 <sup>A</sup>	66 <sup>A</sup>	38 <sup>A</sup>	79 <sup>A</sup>
14	103 <sup>A</sup>	77 <sup>A</sup>	36 <sup>A</sup>	83 <sup>A</sup>
15	98 <sup>A</sup>	71 <sup>A</sup>	39 <sup>A</sup>	74 <sup>A</sup>
16	91 <sup>A</sup>	64 <sup>A</sup>	46 <sup>A</sup>	60 <sup>A</sup>
17	99 <sup>A</sup>	58 <sup>A</sup>	47 <sup>A</sup>	49 <sup>A</sup>
18	125 <sup>A</sup>	55 <sup>A</sup>	51 <sup>A</sup>	39 <sup>A</sup>
19	116 <sup>A</sup>	60 <sup>A</sup>	53 <sup>A</sup>	33 <sup>A</sup>
20	91 <sup>A</sup>	80 <sup>A</sup>	52 <sup>A</sup>	29 <sup>A</sup>
21	80 <sup>A</sup>	77 <sup>A</sup>	48 <sup>A</sup>	24 <sup>A</sup>
22	89 <sup>A</sup>	72 <sup>A</sup>	43 <sup>A</sup>	20 <sup>A</sup>
23	93 <sup>A</sup>	68 <sup>A</sup>	38 <sup>A</sup>	16 <sup>A</sup>
24	87 <sup>A</sup>	62 <sup>A</sup>	37 <sup>A</sup>	15 <sup>A</sup>
25	78 <sup>A</sup>	58 <sup>A</sup>	39 <sup>A</sup>	14 <sup>A</sup>
26	72 <sup>A</sup>	55 <sup>A</sup>	37 <sup>A</sup>	13 <sup>A</sup>
27	67 <sup>A</sup>	51 <sup>A</sup>	29 <sup>A</sup>	12 <sup>A</sup>
28	62 <sup>A</sup>	50 <sup>A</sup>	22 <sup>A</sup>	10 <sup>A</sup>
29	60 <sup>A</sup>	51 <sup>A</sup>	20 <sup>A</sup>	9 <sup>A</sup>
30	58 <sup>A</sup>	50 <sup>A</sup>	24 <sup>A</sup>	8.5 <sup>A</sup>
31	57 <sup>A</sup>		26 <sup>A</sup>	
COUNT	31	30	31	30
MAX	160	80	78	108
MIN	57	50	20	8.5

Daily Mean Discharge, cubic feet per second (cfs)				
DATE	Mar 1996	Apr 1996	May 1996	Jun 1996
1	14 <sup>A</sup>	83 <sup>A</sup>	155 <sup>A</sup>	76 <sup>A</sup>
2	12 <sup>A</sup>	91 <sup>A</sup>	151 <sup>A</sup>	64 <sup>A</sup>
3	12 <sup>A</sup>	98 <sup>A</sup>	136 <sup>A</sup>	57 <sup>A</sup>
4	11 <sup>A</sup>	92 <sup>A</sup>	130 <sup>A</sup>	60 <sup>A</sup>
5	11 <sup>A</sup>	86 <sup>A</sup>	125 <sup>A</sup>	62 <sup>A</sup>
6	13 <sup>A</sup>	81 <sup>A</sup>	120 <sup>A</sup>	59 <sup>A</sup>
7	15 <sup>A</sup>	79 <sup>A</sup>	124 <sup>A</sup>	54 <sup>A</sup>
8	13 <sup>A</sup>	92 <sup>A</sup>	121 <sup>A</sup>	51 <sup>A</sup>
9	135 <sup>A</sup>	112 <sup>A</sup>	116 <sup>A</sup>	46 <sup>A</sup>
10	130 <sup>A</sup>	139 <sup>A</sup>	109 <sup>A</sup>	43 <sup>A</sup>
11	120 <sup>A</sup>	175 <sup>A</sup>	106 <sup>A</sup>	43 <sup>A</sup>
12	117 <sup>A</sup>	201 <sup>A</sup>	125 <sup>A</sup>	36 <sup>A</sup>
13	118 <sup>A</sup>	191 <sup>A</sup>	137 <sup>A</sup>	34 <sup>A</sup>
14	124 <sup>A</sup>	173 <sup>A</sup>	117 <sup>A</sup>	31 <sup>A</sup>
15	137 <sup>A</sup>	163 <sup>A</sup>	103 <sup>A</sup>	27 <sup>A</sup>
16	157 <sup>A</sup>	188 <sup>A</sup>	94 <sup>A</sup>	24 <sup>A</sup>
17	157 <sup>A</sup>	345 <sup>A</sup>	115 <sup>A</sup>	22 <sup>A</sup>
18	150 <sup>A</sup>	308 <sup>A</sup>	133 <sup>A</sup>	20 <sup>A</sup>
19	145 <sup>A</sup>	254 <sup>A</sup>	121 <sup>A</sup>	17 <sup>A</sup>
20	154 <sup>A</sup>	229 <sup>A</sup>	109 <sup>A</sup>	17 <sup>A</sup>
21	161 <sup>A</sup>	209 <sup>A</sup>	100 <sup>A</sup>	20 <sup>A</sup>
22	150 <sup>A</sup>	190 <sup>A</sup>	97 <sup>A</sup>	2 <sup>A</sup>
23	139 <sup>A</sup>	173 <sup>A</sup>	92 <sup>A</sup>	2 <sup>A</sup>
24	132 <sup>A</sup>	159 <sup>A</sup>	83 <sup>A</sup>	18 <sup>A</sup>
25	131 <sup>A</sup>	147 <sup>A</sup>	74 <sup>A</sup>	30 <sup>A</sup>
26	124 <sup>A</sup>	136 <sup>A</sup>	63 <sup>A</sup>	42 <sup>A</sup>
27	113 <sup>A</sup>	128 <sup>A</sup>	55 <sup>A</sup>	32 <sup>A</sup>
28	104 <sup>A</sup>	118 <sup>A</sup>	50 <sup>A</sup>	26 <sup>A</sup>
29	96 <sup>A</sup>	111 <sup>A</sup>	47 <sup>A</sup>	21 <sup>A</sup>
30	90 <sup>A</sup>	131 <sup>A</sup>	55 <sup>A</sup>	17 <sup>A</sup>
31	87 <sup>A</sup>		78 <sup>A</sup>	
COUNT	31	30	31	30
MAX	161	345	155	76
MIN	87	79	47	17

Daily Mean Discharge, cubic feet per second (cfs)				
DATE	Mar 1997	Apr 1997	May 1997	Jun 1997
1	74 <sup>A</sup>	214 <sup>A</sup>	101 <sup>A</sup>	38 <sup>A</sup>
2	8 <sup>A</sup>	256 <sup>A</sup>	105 <sup>A</sup>	36 <sup>A</sup>
3	9 <sup>A</sup>	332 <sup>A</sup>	94 <sup>A</sup>	33 <sup>A</sup>
4	9 <sup>A</sup>	351 <sup>A</sup>	92 <sup>A</sup>	30 <sup>A</sup>
5	85 <sup>A</sup>	430 <sup>A</sup>	85 <sup>A</sup>	28 <sup>A</sup>
6	96 <sup>A</sup>	419 <sup>A</sup>	76 <sup>A</sup>	26 <sup>A</sup>
7	99 <sup>A</sup>	382 <sup>A</sup>	72 <sup>A</sup>	24 <sup>A</sup>
8	90 <sup>A</sup>	344 <sup>A</sup>	65 <sup>A</sup>	23 <sup>A</sup>
9	83 <sup>A</sup>	291 <sup>A</sup>	61 <sup>A</sup>	21 <sup>A</sup>
10	82 <sup>A</sup>	247 <sup>A</sup>	59 <sup>A</sup>	20 <sup>A</sup>
11	88 <sup>A</sup>	218 <sup>A</sup>	56 <sup>A</sup>	18 <sup>A</sup>
12	89 <sup>A</sup>	197 <sup>A</sup>	53 <sup>A</sup>	17 <sup>A</sup>
13	81 <sup>A</sup>	258 <sup>A</sup>	49 <sup>A</sup>	15 <sup>A</sup>
14	75 <sup>A</sup>	287 <sup>A</sup>	51 <sup>A</sup>	15 <sup>A</sup>
15	142 <sup>A</sup>	233 <sup>A</sup>	48 <sup>A</sup>	13 <sup>A</sup>
16	179 <sup>A</sup>	194 <sup>A</sup>	51 <sup>A</sup>	12 <sup>A</sup>
17	153 <sup>A</sup>	167 <sup>A</sup>	51 <sup>A</sup>	11 <sup>A</sup>
18	135 <sup>A</sup>	196 <sup>A</sup>	46 <sup>A</sup>	10 <sup>A</sup>
19	125 <sup>A</sup>	334 <sup>A</sup>	53 <sup>A</sup>	11 <sup>A</sup>
20	119 <sup>A</sup>	413 <sup>A</sup>	79 <sup>A</sup>	11 <sup>A</sup>
21	111 <sup>A</sup>	328 <sup>A</sup>	83 <sup>A</sup>	11 <sup>A</sup>
22	107 <sup>A</sup>	266 <sup>A</sup>	72 <sup>A</sup>	11 <sup>A</sup>
23	104 <sup>A</sup>	227 <sup>A</sup>	62 <sup>A</sup>	15 <sup>A</sup>
24	94 <sup>A</sup>	199 <sup>A</sup>	54 <sup>A</sup>	11 <sup>A</sup>
25	89 <sup>A</sup>	173 <sup>A</sup>	60 <sup>A</sup>	9 <sup>A</sup>
26	99 <sup>A</sup>	147 <sup>A</sup>	90 <sup>A</sup>	8 <sup>A</sup>
27	110 <sup>A</sup>	124 <sup>A</sup>	77 <sup>A</sup>	8 <sup>A</sup>
28	102 <sup>A</sup>	121 <sup>A</sup>	62 <sup>A</sup>	7 <sup>A</sup>
29	98 <sup>A</sup>	144 <sup>A</sup>	52 <sup>A</sup>	7 <sup>A</sup>
30	123 <sup>A</sup>	124 <sup>A</sup>	43 <sup>A</sup>	6.7 <sup>A</sup>
31	131 <sup>A</sup>		41 <sup>A</sup>	
COUNT	31	30	31	30
MAX	179	430	105	38
MIN	74	121	41	6.7

Daily Mean Discharge, cubic feet per second (cfs)				
DATE	Mar 1998	Apr 1998	May 1998	Jun 1998
1	285 <sup>A</sup>	104 <sup>A</sup>	93 <sup>A</sup>	52 <sup>A</sup>
2	287 <sup>A</sup>	143 <sup>A</sup>	110 <sup>A</sup>	54 <sup>A</sup>
3	268 <sup>A</sup>	173 <sup>A</sup>	129 <sup>A</sup>	57 <sup>A</sup>
4	235 <sup>A</sup>	151 <sup>A</sup>	114 <sup>A</sup>	56 <sup>A</sup>
5	21 <sup>A</sup>	132 <sup>A</sup>	116 <sup>A</sup>	48 <sup>A</sup>
6	19 <sup>A</sup>	117 <sup>A</sup>	177 <sup>A</sup>	41 <sup>A</sup>
7	16 <sup>A</sup>	105 <sup>A</sup>	277 <sup>A</sup>	36 <sup>A</sup>
8	14 <sup>A</sup>	95 <sup>A</sup>	268 <sup>A</sup>	37 <sup>A</sup>
9	22 <sup>A</sup>	87 <sup>A</sup>	226 <sup>A</sup>	39 <sup>A</sup>
10	621 <sup>A</sup>	123 <sup>A</sup>	293 <sup>A</sup>	38 <sup>A</sup>
11	551 <sup>A</sup>	145 <sup>A</sup>	440 <sup>A</sup>	35 <sup>A</sup>
12	422 <sup>A</sup>	129 <sup>A</sup>	399 <sup>A</sup>	32 <sup>A</sup>
13	348 <sup>A</sup>	111 <sup>A</sup>	329 <sup>A</sup>	156 <sup>A</sup>
14	306 <sup>A</sup>	97 <sup>A</sup>	284 <sup>A</sup>	1,070 <sup>A</sup>
15	283 <sup>A</sup>	84 <sup>A</sup>	245 <sup>A</sup>	1,110 <sup>A</sup>
16	247 <sup>A</sup>	80 <sup>A</sup>	210 <sup>A</sup>	1,050 <sup>A</sup>
17	216 <sup>A</sup>	100 <sup>A</sup>	182 <sup>A</sup>	818 <sup>A</sup>
18	194 <sup>A</sup>	202 <sup>A</sup>	158 <sup>A</sup>	614 <sup>A</sup>
19	232 <sup>A</sup>	183 <sup>A</sup>	133 <sup>A</sup>	514 <sup>A</sup>
20	320 <sup>A</sup>	177 <sup>A</sup>	110 <sup>A</sup>	450 <sup>A</sup>
21	296 <sup>A</sup>	191 <sup>A</sup>	99 <sup>A</sup>	315 <sup>A</sup>
22	279 <sup>A</sup>	162 <sup>A</sup>	87 <sup>A</sup>	316 <sup>A</sup>
23	264 <sup>A</sup>	145 <sup>A</sup>	73 <sup>A</sup>	268 <sup>A</sup>
24	244 <sup>A</sup>	185 <sup>A</sup>	64 <sup>A</sup>	227 <sup>A</sup>
25	217 <sup>A</sup>	189 <sup>A</sup>	59 <sup>A</sup>	204 <sup>A</sup>
26	194 <sup>A</sup>	162 <sup>A</sup>	55 <sup>A</sup>	173 <sup>A</sup>
27	177 <sup>A</sup>	149 <sup>A</sup>	51 <sup>A</sup>	142 <sup>A</sup>
28	161 <sup>A</sup>	134 <sup>A</sup>	47 <sup>A</sup>	124 <sup>A</sup>
29	147 <sup>A</sup>	117 <sup>A</sup>	43 <sup>A</sup>	114 <sup>A</sup>
30	130 <sup>A</sup>	103 <sup>A</sup>	40 <sup>A</sup>	268 <sup>A</sup>
31	114 <sup>A</sup>		40 <sup>A</sup>	
COUNT	31	30	31	30
MAX	621	202	440	1,110
MIN	114	80	40	32

Daily Mean Discharge, cubic feet per second (cfs)				
DATE	Mar 1999	Apr 1999	May 1999	Jun 1999
1	265 <sup>A</sup>	107 <sup>A</sup>	39 <sup>A</sup>	37 <sup>A</sup>
2	319 <sup>A</sup>	101 <sup>A</sup>	37 <sup>A</sup>	31 <sup>A</sup>
3	247 <sup>A</sup>	95 <sup>A</sup>	35 <sup>A</sup>	27 <sup>A</sup>
4	240 <sup>A</sup>	89 <sup>A</sup>	37 <sup>A</sup>	24 <sup>A</sup>
5	250 <sup>A</sup>	83 <sup>A</sup>	48 <sup>A</sup>	21 <sup>A</sup>
6	215 <sup>A</sup>	79 <sup>A</sup>	53 <sup>A</sup>	18 <sup>A</sup>
7	210 <sup>A</sup>	75 <sup>A</sup>	50 <sup>A</sup>	17 <sup>A</sup>
8	190 <sup>A</sup>	71 <sup>A</sup>	49 <sup>A</sup>	15 <sup>A</sup>
9	170 <sup>A</sup>	68 <sup>A</sup>	59 <sup>A</sup>	13 <sup>A</sup>
10	159 <sup>A</sup>	67 <sup>A</sup>	53 <sup>A</sup>	11 <sup>A</sup>
11	142 <sup>A</sup>	65 <sup>A</sup>	45 <sup>A</sup>	10 <sup>A</sup>
12	134 <sup>A</sup>	63 <sup>A</sup>	37 <sup>A</sup>	9.0 <sup>A</sup>
13	130 <sup>A</sup>	61 <sup>A</sup>	28 <sup>A</sup>	8.4 <sup>A</sup>
14	126 <sup>A</sup>	57 <sup>A</sup>	27 <sup>A</sup>	7.9 <sup>A</sup>
15	126 <sup>A</sup>	55 <sup>A</sup>	27 <sup>A</sup>	7.5 <sup>A</sup>
16	133 <sup>A</sup>	52 <sup>A</sup>	25 <sup>A</sup>	7.5 <sup>A</sup>
17	136 <sup>A</sup>	60 <sup>A</sup>	23 <sup>A</sup>	6.8 <sup>A</sup>
18	160 <sup>A</sup>	67 <sup>A</sup>	22 <sup>A</sup>	6.6 <sup>A</sup>
19	148 <sup>A</sup>	63 <sup>A</sup>	22 <sup>A</sup>	6.1 <sup>A</sup>
20	134 <sup>A</sup>	58 <sup>A</sup>	30 <sup>A</sup>	5.5 <sup>A</sup>
21	121 <sup>A</sup>	55 <sup>A</sup>	37 <sup>A</sup>	5.0 <sup>A</sup>
22	124 <sup>A</sup>	53 <sup>A</sup>	32 <sup>A</sup>	4.7 <sup>A</sup>
23	136 <sup>A</sup>	54 <sup>A</sup>	28 <sup>A</sup>	4.2 <sup>A</sup>
24	131 <sup>A</sup>	62 <sup>A</sup>	66 <sup>A</sup>	3.7 <sup>A</sup>
25	140 <sup>A</sup>	61 <sup>A</sup>	124 <sup>A</sup>	3.1 <sup>A</sup>
26	135 <sup>A</sup>	55 <sup>A</sup>	112 <sup>A</sup>	2.8 <sup>A</sup>
27	125 <sup>A</sup>	51 <sup>A</sup>	89 <sup>A</sup>	2.7 <sup>A</sup>
28	130 <sup>A</sup>	48 <sup>A</sup>	74 <sup>A</sup>	2.5 <sup>A</sup>
29	146 <sup>A</sup>	45 <sup>A</sup>	65 <sup>A</sup>	2.5 <sup>A</sup>
30	131 <sup>A</sup>	42 <sup>A</sup>	54 <sup>A</sup>	2.5 <sup>A</sup>
31	115 <sup>A</sup>		45 <sup>A</sup>	
COUNT	31	30	31	30
MAX	319	107	124	37
MIN	115	42	22	2.5

Figure 63. HDM continued



Daily Mean Discharge, cubic feet per second (cfs)				
DATE	Mar 2000	Apr 2000	May 2000	Jun 2000
1	167 <sup>A</sup>	159 <sup>A</sup>	159 <sup>A</sup>	56 <sup>A</sup>
2	151 <sup>A</sup>	145 <sup>A</sup>	144 <sup>A</sup>	54 <sup>A</sup>
3	134 <sup>A</sup>	133 <sup>A</sup>	133 <sup>A</sup>	63 <sup>A</sup>
4	121 <sup>A</sup>	125 <sup>A</sup>	120 <sup>A</sup>	63 <sup>A</sup>
5	111 <sup>A</sup>	129 <sup>A</sup>	110 <sup>A</sup>	54 <sup>A</sup>
6	95 <sup>A</sup>	121 <sup>A</sup>	101 <sup>A</sup>	62 <sup>A</sup>
7	92 <sup>A</sup>	108 <sup>A</sup>	96 <sup>A</sup>	149 <sup>A</sup>
8	83 <sup>A</sup>	97 <sup>A</sup>	90 <sup>A</sup>	189 <sup>A</sup>
9	75 <sup>A</sup>	106 <sup>A</sup>	98 <sup>A</sup>	152 <sup>A</sup>
10	76 <sup>A</sup>	117 <sup>A</sup>	96 <sup>A</sup>	131 <sup>A</sup>
11	77 <sup>A</sup>	110 <sup>A</sup>	133 <sup>A</sup>	114 <sup>A</sup>
12	160 <sup>A</sup>	103 <sup>A</sup>	134 <sup>A</sup>	104 <sup>A</sup>
13	214 <sup>A</sup>	96 <sup>A</sup>	116 <sup>A</sup>	96 <sup>A</sup>
14	180 <sup>A</sup>	88 <sup>A</sup>	112 <sup>A</sup>	83 <sup>A</sup>
15	153 <sup>A</sup>	81 <sup>A</sup>	106 <sup>A</sup>	75 <sup>A</sup>
16	139 <sup>A</sup>	85 <sup>A</sup>	93 <sup>A</sup>	69 <sup>A</sup>
17	180 <sup>A</sup>	92 <sup>A</sup>	81 <sup>A</sup>	66 <sup>A</sup>
18	211 <sup>A</sup>	87 <sup>A</sup>	72 <sup>A</sup>	65 <sup>A</sup>
19	188 <sup>A</sup>	101 <sup>A</sup>	85 <sup>A</sup>	62 <sup>A</sup>
20	168 <sup>A</sup>	110 <sup>A</sup>	112 <sup>A</sup>	55 <sup>A</sup>
21	153 <sup>A</sup>	103 <sup>A</sup>	104 <sup>A</sup>	48 <sup>A</sup>
22	140 <sup>A</sup>	278 <sup>A</sup>	91 <sup>A</sup>	42 <sup>A</sup>
23	129 <sup>A</sup>	443 <sup>A</sup>	99 <sup>A</sup>	38 <sup>A</sup>
24	119 <sup>A</sup>	348 <sup>A</sup>	122 <sup>A</sup>	34 <sup>A</sup>
25	109 <sup>A</sup>	287 <sup>A</sup>	157 <sup>A</sup>	29 <sup>A</sup>
26	101 <sup>A</sup>	250 <sup>A</sup>	137 <sup>A</sup>	26 <sup>A</sup>
27	95 <sup>A</sup>	254 <sup>A</sup>	113 <sup>A</sup>	27 <sup>A</sup>
28	140 <sup>A</sup>	228 <sup>A</sup>	95 <sup>A</sup>	35 <sup>A</sup>
29	224 <sup>A</sup>	200 <sup>A</sup>	83 <sup>A</sup>	34 <sup>A</sup>
30	207 <sup>A</sup>	176 <sup>A</sup>	74 <sup>A</sup>	32 <sup>A</sup>
31	178 <sup>A</sup>		67 <sup>A</sup>	
COUNT	31	30	31	30
MAX	224	443	159	189
MIN	76	81	67	26

Daily Mean Discharge, cubic feet per second (cfs)				
DATE	Mar 2001	Apr 2001	May 2001	Jun 2001
1	81 <sup>A</sup>	504 <sup>A</sup>	57 <sup>A</sup>	54 <sup>A</sup>
2	78 <sup>A</sup>	396 <sup>A</sup>	55 <sup>A</sup>	70 <sup>A</sup>
3	74 <sup>A</sup>	334 <sup>A</sup>	52 <sup>A</sup>	140 <sup>A</sup>
4	72 <sup>A</sup>	288 <sup>A</sup>	48 <sup>A</sup>	123 <sup>A</sup>
5	70 <sup>A</sup>	248 <sup>A</sup>	44 <sup>A</sup>	98 <sup>A</sup>
6	82 <sup>A</sup>	218 <sup>A</sup>	40 <sup>A</sup>	80 <sup>A</sup>
7	103 <sup>A</sup>	206 <sup>A</sup>	37 <sup>A</sup>	66 <sup>A</sup>
8	113 <sup>A</sup>	215 <sup>A</sup>	34 <sup>A</sup>	55 <sup>A</sup>
9	105 <sup>A</sup>	237 <sup>A</sup>	32 <sup>A</sup>	46 <sup>A</sup>
10	102 <sup>A</sup>	214 <sup>A</sup>	30 <sup>A</sup>	39 <sup>A</sup>
11	108 <sup>A</sup>	187 <sup>A</sup>	29 <sup>A</sup>	33 <sup>A</sup>
12	112 <sup>A</sup>	176 <sup>A</sup>	27 <sup>A</sup>	42 <sup>A</sup>
13	140 <sup>A</sup>	177 <sup>A</sup>	25 <sup>A</sup>	43 <sup>A</sup>
14	191 <sup>A</sup>	167 <sup>A</sup>	24 <sup>A</sup>	39 <sup>A</sup>
15	196 <sup>A</sup>	151 <sup>A</sup>	23 <sup>A</sup>	31 <sup>A</sup>
16	194 <sup>A</sup>	139 <sup>A</sup>	22 <sup>A</sup>	26 <sup>A</sup>
17	197 <sup>A</sup>	129 <sup>A</sup>	22 <sup>A</sup>	64 <sup>A</sup>
18	200 <sup>A</sup>	122 <sup>A</sup>	22 <sup>A</sup>	269 <sup>A</sup>
19	194 <sup>A</sup>	122 <sup>A</sup>	22 <sup>A</sup>	253 <sup>A</sup>
20	185 <sup>A</sup>	114 <sup>A</sup>	21 <sup>A</sup>	167 <sup>A</sup>
21	176 <sup>A</sup>	105 <sup>A</sup>	20 <sup>A</sup>	117 <sup>A</sup>
22	409 <sup>A</sup>	101 <sup>A</sup>	21 <sup>A</sup>	10 <sup>A</sup>
23	648 <sup>A</sup>	95 <sup>A</sup>	28 <sup>A</sup>	10 <sup>A</sup>
24	501 <sup>A</sup>	84 <sup>A</sup>	71 <sup>A</sup>	84 <sup>A</sup>
25	413 <sup>A</sup>	81 <sup>A</sup>	117 <sup>A</sup>	73 <sup>A</sup>
26	349 <sup>A</sup>	76 <sup>A</sup>	93 <sup>A</sup>	60 <sup>A</sup>
27	308 <sup>A</sup>	72 <sup>A</sup>	79 <sup>A</sup>	47 <sup>A</sup>
28	276 <sup>A</sup>	68 <sup>A</sup>	78 <sup>A</sup>	38 <sup>A</sup>
29	245 <sup>A</sup>	64 <sup>A</sup>	76 <sup>A</sup>	30 <sup>A</sup>
30	335 <sup>A</sup>	60 <sup>A</sup>	76 <sup>A</sup>	24 <sup>A</sup>
31	645 <sup>A</sup>		67 <sup>A</sup>	
COUNT	31	30	31	30
MAX	648	504	117	269
MIN	70	60	20	24

Daily Mean Discharge, cubic feet per second (cfs)				
DATE	Mar 2002	Apr 2002	May 2002	Jun 2002
1	45 <sup>A</sup>	136 <sup>A</sup>	70 <sup>A</sup>	61 <sup>A</sup>
2	44 <sup>A</sup>	163 <sup>A</sup>	65 <sup>A</sup>	57 <sup>A</sup>
3	70 <sup>A</sup>	140 <sup>A</sup>	92 <sup>A</sup>	51 <sup>A</sup>
4	118 <sup>A</sup>	125 <sup>A</sup>	116 <sup>A</sup>	44 <sup>A</sup>
5	103 <sup>A</sup>	112 <sup>A</sup>	94 <sup>A</sup>	40 <sup>A</sup>
6	85 <sup>A</sup>	101 <sup>A</sup>	78 <sup>A</sup>	58 <sup>A</sup>
7	72 <sup>A</sup>	92 <sup>A</sup>	70 <sup>A</sup>	118 <sup>A</sup>
8	65 <sup>A</sup>	83 <sup>A</sup>	64 <sup>A</sup>	147 <sup>A</sup>
9	60 <sup>A</sup>	77 <sup>A</sup>	58 <sup>A</sup>	123 <sup>A</sup>
10	67 <sup>A</sup>	74 <sup>A</sup>	62 <sup>A</sup>	103 <sup>A</sup>
11	78 <sup>A</sup>	69 <sup>A</sup>	59 <sup>A</sup>	84 <sup>A</sup>
12	70 <sup>A</sup>	66 <sup>A</sup>	52 <sup>A</sup>	73 <sup>A</sup>
13	63 <sup>A</sup>	62 <sup>A</sup>	74 <sup>A</sup>	65 <sup>A</sup>
14	59 <sup>A</sup>	60 <sup>A</sup>	201 <sup>A</sup>	58 <sup>A</sup>
15	55 <sup>A</sup>	57 <sup>A</sup>	228 <sup>A</sup>	61 <sup>A</sup>
16	55 <sup>A</sup>	55 <sup>A</sup>	179 <sup>A</sup>	70 <sup>A</sup>
17	55 <sup>A</sup>	52 <sup>A</sup>	155 <sup>A</sup>	65 <sup>A</sup>
18	53 <sup>A</sup>	50 <sup>A</sup>	169 <sup>A</sup>	57 <sup>A</sup>
19	56 <sup>A</sup>	47 <sup>A</sup>	227 <sup>A</sup>	48 <sup>A</sup>
20	63 <sup>A</sup>	44 <sup>A</sup>	190 <sup>A</sup>	42 <sup>A</sup>
21	88 <sup>A</sup>	41 <sup>A</sup>	160 <sup>A</sup>	38 <sup>A</sup>
22	101 <sup>A</sup>	40 <sup>A</sup>	141 <sup>A</sup>	33 <sup>A</sup>
23	89 <sup>A</sup>	41 <sup>A</sup>	124 <sup>A</sup>	29 <sup>A</sup>
24	79 <sup>A</sup>	41 <sup>A</sup>	106 <sup>A</sup>	27 <sup>A</sup>
25	72 <sup>A</sup>	41 <sup>A</sup>	90 <sup>A</sup>	24 <sup>A</sup>
26	68 <sup>A</sup>	61 <sup>A</sup>	80 <sup>A</sup>	23 <sup>A</sup>
27	115 <sup>A</sup>	67 <sup>A</sup>	73 <sup>A</sup>	23 <sup>A</sup>
28	136 <sup>A</sup>	62 <sup>A</sup>	67 <sup>A</sup>	22 <sup>A</sup>
29	118 <sup>A</sup>	72 <sup>A</sup>	64 <sup>A</sup>	20 <sup>A</sup>
30	106 <sup>A</sup>	74 <sup>A</sup>	63 <sup>A</sup>	16 <sup>A</sup>
31	100 <sup>A</sup>		57 <sup>A</sup>	
COUNT	31	30	31	30
MAX	136	163	228	147
MIN	40	40	52	16

Daily Mean Discharge, cubic feet per second (cfs)				
DATE	Mar 2003	Apr 2003	May 2003	Jun 2003
1	111 <sup>A</sup>	304 <sup>A</sup>	121 <sup>A</sup>	120 <sup>A</sup>
2	125 <sup>A</sup>	259 <sup>A</sup>	112 <sup>A</sup>	169 <sup>A</sup>
3	200 <sup>A</sup>	230 <sup>A</sup>	103 <sup>A</sup>	152 <sup>A</sup>
4	210 <sup>A</sup>	219 <sup>A</sup>	96 <sup>A</sup>	125 <sup>A</sup>
5	163 <sup>A</sup>	206 <sup>A</sup>	88 <sup>A</sup>	119 <sup>A</sup>
6	159 <sup>A</sup>	191 <sup>A</sup>	83 <sup>A</sup>	116 <sup>A</sup>
7	143 <sup>A</sup>	172 <sup>A</sup>	107 <sup>A</sup>	106 <sup>A</sup>
8	132 <sup>A</sup>	161 <sup>A</sup>	72 <sup>A</sup>	112 <sup>A</sup>
9	133 <sup>A</sup>	159 <sup>A</sup>	68 <sup>A</sup>	110 <sup>A</sup>
10	127 <sup>A</sup>	164 <sup>A</sup>	64 <sup>A</sup>	99 <sup>A</sup>
11	122 <sup>A</sup>	170 <sup>A</sup>	61 <sup>A</sup>	83 <sup>A</sup>
12	120 <sup>A</sup>	304 <sup>A</sup>	64 <sup>A</sup>	77 <sup>A</sup>
13	127 <sup>A</sup>	314 <sup>A</sup>	67 <sup>A</sup>	83 <sup>A</sup>
14	117 <sup>A</sup>	260 <sup>A</sup>	66 <sup>A</sup>	99 <sup>A</sup>
15	110 <sup>A</sup>	222 <sup>A</sup>	62 <sup>A</sup>	105 <sup>A</sup>
16	113 <sup>A</sup>	199 <sup>A</sup>	55 <sup>A</sup>	93 <sup>A</sup>
17	134 <sup>A</sup>	174 <sup>A</sup>	53 <sup>A</sup>	79 <sup>A</sup>
18	164 <sup>A</sup>	154 <sup>A</sup>	50 <sup>A</sup>	71 <sup>A</sup>
19	169 <sup>A</sup>	139 <sup>A</sup>	46 <sup>A</sup>	77 <sup>A</sup>
20	160 <sup>A</sup>	128 <sup>A</sup>	43 <sup>A</sup>	72 <sup>A</sup>
21	192 <sup>A</sup>	117 <sup>A</sup>	41 <sup>A</sup>	61 <sup>A</sup>
22	232 <sup>A</sup>	121 <sup>A</sup>	42 <sup>A</sup>	102 <sup>A</sup>
23	212 <sup>A</sup>	151 <sup>A</sup>	47 <sup>A</sup>	248 <sup>A</sup>
24	192 <sup>A</sup>	144 <sup>A</sup>	54 <sup>A</sup>	253 <sup>A</sup>
25	174 <sup>A</sup>	129 <sup>A</sup>	60 <sup>A</sup>	209 <sup>A</sup>
26	161 <sup>A</sup>	127 <sup>A</sup>	72 <sup>A</sup>	177 <sup>A</sup>
27	152 <sup>A</sup>	178 <sup>A</sup>	151 <sup>A</sup>	147 <sup>A</sup>
28	140 <sup>A</sup>	172 <sup>A</sup>	155 <sup>A</sup>	111 <sup>A</sup>
29	129 <sup>A</sup>	151 <sup>A</sup>	134 <sup>A</sup>	95 <sup>A</sup>
30	229 <sup>A</sup>	135 <sup>A</sup>	120 <sup>A</sup>	86 <sup>A</sup>
31	371 <sup>A</sup>		107 <sup>A</sup>	
COUNT	31	30	31	30
MAX	371	314	155	252
MIN	110	117	41	65

Daily Mean Discharge, cubic feet per second (cfs)				
DATE	Mar 2004	Apr 2004	May 2004	Jun 2004
1	38 <sup>A</sup>	183 <sup>A</sup>	144 <sup>A</sup>	63 <sup>A</sup>
2	48 <sup>A</sup>	349 <sup>A</sup>	131 <sup>A</sup>	66 <sup>A</sup>
3	58 <sup>A</sup>	305 <sup>A</sup>	125 <sup>A</sup>	73 <sup>A</sup>
4	60 <sup>A</sup>	266 <sup>A</sup>	148 <sup>A</sup>	68 <sup>A</sup>
5	68 <sup>A</sup>	274 <sup>A</sup>	153 <sup>A</sup>	59 <sup>A</sup>
6	73 <sup>A</sup>	235 <sup>A</sup>	136 <sup>A</sup>	53 <sup>A</sup>
7	91 <sup>A</sup>	194 <sup>A</sup>	122 <sup>A</sup>	54 <sup>A</sup>
8	83 <sup>A</sup>	168 <sup>A</sup>	109 <sup>A</sup>	51 <sup>A</sup>
9	80 <sup>A</sup>	150 <sup>A</sup>	101 <sup>A</sup>	44 <sup>A</sup>
10	76 <sup>A</sup>	133 <sup>A</sup>	106 <sup>A</sup>	39 <sup>A</sup>
11	72 <sup>A</sup>	117 <sup>A</sup>	100 <sup>A</sup>	37 <sup>A</sup>
12	67 <sup>A</sup>	106 <sup>A</sup>	93 <sup>A</sup>	32 <sup>A</sup>
13	61 <sup>A</sup>	132 <sup>A</sup>	84 <sup>A</sup>	28 <sup>A</sup>
14	56 <sup>A</sup>	427 <sup>A</sup>	76 <sup>A</sup>	25 <sup>A</sup>
15	53 <sup>A</sup>	476 <sup>A</sup>	71 <sup>A</sup>	23 <sup>A</sup>
16	51 <sup>A</sup>	376 <sup>A</sup>	67 <sup>A</sup>	21 <sup>A</sup>
17	50 <sup>A</sup>	319 <sup>A</sup>	62 <sup>A</sup>	20 <sup>A</sup>
18	49 <sup>A</sup>	254 <sup>A</sup>	58 <sup>A</sup>	16 <sup>A</sup>
19	48 <sup>A</sup>	215 <sup>A</sup>	58 <sup>A</sup>	17 <sup>A</sup>
20	47 <sup>A</sup>	186 <sup>A</sup>	58 <sup>A</sup>	20 <sup>A</sup>
21	71 <sup>A</sup>	164 <sup>A</sup>	56 <sup>A</sup>	20 <sup>A</sup>
22	98 <sup>A</sup>	146 <sup>A</sup>	52 <sup>A</sup>	16 <sup>A</sup>
23	90 <sup>A</sup>	142 <sup>A</sup>	52 <sup>A</sup>	16 <sup>A</sup>
24	80 <sup>A</sup>	162 <sup>A</sup>	51 <sup>A</sup>	17 <sup>A</sup>
25	75 <sup>A</sup>	151 <sup>A</sup>	52 <sup>A</sup>	15 <sup>A</sup>
26	72 <sup>A</sup>	145 <sup>A</sup>	53 <sup>A</sup>	12 <sup>A</sup>
27	74 <sup>A</sup>	203 <sup>A</sup>	65 <sup>A</sup>	12 <sup>A</sup>
28	76 <sup>A</sup>	208 <sup>A</sup>	80 <sup>A</sup>	12 <sup>A</sup>
29	73 <sup>A</sup>	179 <sup>A</sup>	94 <sup>A</sup>	11 <sup>A</sup>
30	67 <sup>A</sup>	159 <sup>A</sup>	81 <sup>A</sup>	10 <sup>A</sup>
31	68 <sup>A</sup>		68 <sup>A</sup>	
COUNT	31	30	31	30
MAX	98	476	153	73
MIN	38	106	51	10

Figure 64. HDM continued.

Daily Mean Discharge, cubic feet per second (cfs)				
DATE	Mar 2005	Apr 2005	May 2005	Jun 2005
1	81 <sup>A</sup>	327 <sup>A</sup>	156 <sup>A</sup>	127 <sup>A</sup>
2	91 <sup>A</sup>	366 <sup>A</sup>	156 <sup>A</sup>	110 <sup>A</sup>
3	90 <sup>A</sup>	481 <sup>A</sup>	137 <sup>A</sup>	95 <sup>A</sup>
4	81 <sup>A</sup>	433 <sup>A</sup>	121 <sup>A</sup>	85 <sup>A</sup>
5	80 <sup>A</sup>	313 <sup>A</sup>	108 <sup>A</sup>	74 <sup>A</sup>
6	75 <sup>A</sup>	307 <sup>A</sup>	99 <sup>A</sup>	64 <sup>A</sup>
7	75 <sup>A</sup>	251 <sup>A</sup>	109 <sup>A</sup>	58 <sup>A</sup>
8	101 <sup>A</sup>	247 <sup>A</sup>	145 <sup>A</sup>	53 <sup>A</sup>
9	132 <sup>A</sup>	230 <sup>A</sup>	139 <sup>A</sup>	49 <sup>A</sup>
10	138 <sup>A</sup>	183 <sup>A</sup>	125 <sup>A</sup>	44 <sup>A</sup>
11	124 <sup>A</sup>	164 <sup>A</sup>	115 <sup>A</sup>	40 <sup>A</sup>
12	120 <sup>A</sup>	149 <sup>A</sup>	103 <sup>A</sup>	37 <sup>A</sup>
13	128 <sup>A</sup>	143 <sup>A</sup>	92 <sup>A</sup>	34 <sup>A</sup>
14	137 <sup>A</sup>	133 <sup>A</sup>	84 <sup>A</sup>	32 <sup>A</sup>
15	131 <sup>A</sup>	123 <sup>A</sup>	80 <sup>A</sup>	31 <sup>A</sup>
16	127 <sup>A</sup>	111 <sup>A</sup>	77 <sup>A</sup>	31 <sup>A</sup>
17	126 <sup>A</sup>	105 <sup>A</sup>	73 <sup>A</sup>	31 <sup>A</sup>
18	125 <sup>A</sup>	96 <sup>A</sup>	69 <sup>A</sup>	30 <sup>A</sup>
19	126 <sup>A</sup>	92 <sup>A</sup>	66 <sup>A</sup>	30 <sup>A</sup>
20	126 <sup>A</sup>	86 <sup>A</sup>	62 <sup>A</sup>	28 <sup>A</sup>
21	126 <sup>A</sup>	83 <sup>A</sup>	57 <sup>A</sup>	26 <sup>A</sup>
22	125 <sup>A</sup>	81 <sup>A</sup>	54 <sup>A</sup>	24 <sup>A</sup>
23	125 <sup>A</sup>	81 <sup>A</sup>	52 <sup>A</sup>	23 <sup>A</sup>
24	130 <sup>A</sup>	112 <sup>A</sup>	54 <sup>A</sup>	22 <sup>A</sup>
25	146 <sup>A</sup>	144 <sup>A</sup>	95 <sup>A</sup>	19 <sup>A</sup>
26	142 <sup>A</sup>	130 <sup>A</sup>	209 <sup>A</sup>	18 <sup>A</sup>
27	134 <sup>A</sup>	125 <sup>A</sup>	225 <sup>A</sup>	16 <sup>A</sup>
28	187 <sup>A</sup>	155 <sup>A</sup>	194 <sup>A</sup>	15 <sup>A</sup>
29	711 <sup>A</sup>	146 <sup>A</sup>	171 <sup>A</sup>	14 <sup>A</sup>
30	558 <sup>A</sup>	129 <sup>A</sup>	163 <sup>A</sup>	14 <sup>A</sup>
31	380 <sup>A</sup>		145 <sup>A</sup>	
COUNT	31	30	31	30
MAX	711	481	225	127
MIN	78	81	52	14

Daily Mean Discharge, cubic feet per second (cfs)				
DATE	Mar 2006	Apr 2006	May 2006	Jun 2006
1	60 <sup>A</sup>	32 <sup>A</sup>	33 <sup>A</sup>	64 <sup>A</sup>
2	58 <sup>A</sup>	31 <sup>A</sup>	40 <sup>A</sup>	61 <sup>A</sup>
3	56 <sup>A</sup>	27 <sup>A</sup>	79 <sup>A</sup>	100 <sup>A</sup>
4	55 <sup>A</sup>	32 <sup>A</sup>	95 <sup>A</sup>	248 <sup>A</sup>
5	56 <sup>A</sup>	46 <sup>A</sup>	85 <sup>A</sup>	274 <sup>A</sup>
6	55 <sup>A</sup>	50 <sup>A</sup>	75 <sup>A</sup>	228 <sup>A</sup>
7	54 <sup>A</sup>	48 <sup>A</sup>	65 <sup>A</sup>	460 <sup>A</sup>
8	57 <sup>A</sup>	50 <sup>A</sup>	56 <sup>A</sup>	853 <sup>A</sup>
9	59 <sup>A</sup>	58 <sup>A</sup>	50 <sup>A</sup>	622 <sup>A</sup>
10	60 <sup>A</sup>	56 <sup>A</sup>	56 <sup>A</sup>	490 <sup>A</sup>
11	63 <sup>A</sup>	48 <sup>A</sup>	56 <sup>A</sup>	430 <sup>A</sup>
12	62 <sup>A</sup>	45 <sup>A</sup>	55 <sup>A</sup>	356 <sup>A</sup>
13	60 <sup>A</sup>	43 <sup>A</sup>	111 <sup>A</sup>	296 <sup>A</sup>
14	62 <sup>A</sup>	40 <sup>A</sup>	276 <sup>A</sup>	234 <sup>A</sup>
15	63 <sup>A</sup>	38 <sup>A</sup>	369 <sup>A</sup>	188 <sup>A</sup>
16	59 <sup>A</sup>	36 <sup>A</sup>	324 <sup>A</sup>	169 <sup>A</sup>
17	55 <sup>A</sup>	33 <sup>A</sup>	297 <sup>A</sup>	147 <sup>A</sup>
18	52 <sup>A</sup>	30 <sup>A</sup>	241 <sup>A</sup>	135 <sup>A</sup>
19	50 <sup>A</sup>	28 <sup>A</sup>	200 <sup>A</sup>	121 <sup>A</sup>
20	48 <sup>A</sup>	25 <sup>A</sup>	216 <sup>A</sup>	105 <sup>A</sup>
21	45 <sup>A</sup>	23 <sup>A</sup>	195 <sup>A</sup>	94 <sup>A</sup>
22	43 <sup>A</sup>	22 <sup>A</sup>	173 <sup>A</sup>	90 <sup>A</sup>
23	41 <sup>A</sup>	23 <sup>A</sup>	153 <sup>A</sup>	82 <sup>A</sup>
24	40 <sup>A</sup>	60 <sup>A</sup>	138 <sup>A</sup>	13 <sup>A</sup>
25	39 <sup>A</sup>	71 <sup>A</sup>	121 <sup>A</sup>	50 <sup>A</sup>
26	38 <sup>A</sup>	57 <sup>A</sup>	110 <sup>A</sup>	54 <sup>A</sup>
27	38 <sup>A</sup>	50 <sup>A</sup>	106 <sup>A</sup>	38 <sup>A</sup>
28	36 <sup>A</sup>	47 <sup>A</sup>	99 <sup>A</sup>	30 <sup>A</sup>
29	35 <sup>A</sup>	42 <sup>A</sup>	88 <sup>A</sup>	26 <sup>A</sup>
30	34 <sup>A</sup>	38 <sup>A</sup>	79 <sup>A</sup>	23 <sup>A</sup>
31	33 <sup>A</sup>		69 <sup>A</sup>	
COUNT	31	30	31	30
MAX	63	71	369	853
MIN	33	22	33	61

Daily Mean Discharge, cubic feet per second (cfs)				
DATE	Mar 2007	Apr 2007	May 2007	Jun 2007
1	57 <sup>P</sup>	146 <sup>P</sup>	172 <sup>P</sup>	44 <sup>P</sup>
2	172 <sup>P</sup>	148 <sup>P</sup>	157 <sup>P</sup>	42 <sup>P</sup>
3	386 <sup>P</sup>	159 <sup>P</sup>	143 <sup>P</sup>	54 <sup>P</sup>
4	282 <sup>P</sup>	152 <sup>P</sup>	128 <sup>P</sup>	104 <sup>P</sup>
5	232 <sup>P</sup>	222 <sup>P</sup>	116 <sup>P</sup>	185 <sup>P</sup>
6	189 <sup>P</sup>	235 <sup>P</sup>	107 <sup>P</sup>	152 <sup>P</sup>
7	147 <sup>P</sup>	199 <sup>P</sup>	99 <sup>P</sup>	126 <sup>P</sup>
8	117 <sup>P</sup>	179 <sup>P</sup>	93 <sup>P</sup>	109 <sup>P</sup>
9	94 <sup>P</sup>	163 <sup>P</sup>	81 <sup>P</sup>	94 <sup>P</sup>
10	91 <sup>P</sup>	150 <sup>P</sup>	73 <sup>P</sup>	83 <sup>P</sup>
11	94 <sup>P</sup>	139 <sup>P</sup>	72 <sup>P</sup>	73 <sup>P</sup>
12	103 <sup>P</sup>	138 <sup>P</sup>	69 <sup>P</sup>	64 <sup>P</sup>
13	103 <sup>P</sup>	187 <sup>P</sup>	66 <sup>P</sup>	57 <sup>P</sup>
14	102 <sup>P</sup>	183 <sup>P</sup>	62 <sup>P</sup>	52 <sup>P</sup>
15	104 <sup>P</sup>	177 <sup>P</sup>	57 <sup>P</sup>	47 <sup>P</sup>
16	110 <sup>P</sup>	479 <sup>P</sup>	55 <sup>P</sup>	42 <sup>P</sup>
17	188 <sup>P</sup>	520 <sup>P</sup>	63 <sup>P</sup>	37 <sup>P</sup>
18	282 <sup>P</sup>	425 <sup>P</sup>	81 <sup>P</sup>	37 <sup>P</sup>
19	248 <sup>P</sup>	394 <sup>P</sup>	162 <sup>P</sup>	35 <sup>P</sup>
20	225 <sup>P</sup>	338 <sup>P</sup>	193 <sup>P</sup>	30 <sup>P</sup>
21	222 <sup>P</sup>	290 <sup>P</sup>	185 <sup>P</sup>	31 <sup>P</sup>
22	203 <sup>P</sup>	248 <sup>P</sup>	167 <sup>P</sup>	31 <sup>P</sup>
23	209 <sup>P</sup>	210 <sup>P</sup>	146 <sup>P</sup>	31 <sup>P</sup>
24	208 <sup>P</sup>	180 <sup>P</sup>	130 <sup>P</sup>	27 <sup>P</sup>
25	202 <sup>P</sup>	158 <sup>P</sup>	112 <sup>P</sup>	27 <sup>P</sup>
26	202 <sup>P</sup>	153 <sup>P</sup>	92 <sup>P</sup>	19 <sup>P</sup>
27	218 <sup>P</sup>	178 <sup>P</sup>	75 <sup>P</sup>	16 <sup>P</sup>
28	213 <sup>P</sup>	242 <sup>P</sup>	62 <sup>P</sup>	15 <sup>P</sup>
29	189 <sup>P</sup>	216 <sup>P</sup>	57 <sup>P</sup>	14 <sup>P</sup>
30	169 <sup>P</sup>	192 <sup>P</sup>	53 <sup>P</sup>	13 <sup>P</sup>
31	156 <sup>P</sup>		49 <sup>P</sup>	
COUNT	31	30	31	30
MAX	386	520	193	185
MIN	57	138	49	13

Figure 65. HDM continued.



Table 22. Flows Greater than 230 cfs.

Flows greater than 230 cfs																							
1990		1993		1994		1996		1997		1998		2000		2001		2003		2004		2005		2006	
dates	flows	dates	flows	dates	flows	dates	flows	dates	flows	dates	flows	dates	flows	dates	flows	dates	flows	dates	flows	dates	flows	dates	flows
4-Apr	240	18-Mar	232	11-Mar	640	17-Apr	345	2-Apr	256	10-Mar	621	22-Apr	278	22-Mar	409	31-Mar	371	2-Apr	349	29-Mar	711	14-May	276
5-Apr	256	19-Mar	250	12-Mar	450	18-Apr	308	3-Apr	332	11-Mar	551	23-Apr	443	23-Mar	648	1-Apr	304	3-Apr	305	30-Mar	558	15-May	369
				13-Mar	353	19-Apr	254	4-Apr	351	12-Mar	422	24-Apr	348	24-Mar	501	2-Apr	259	4-Apr	266	31-Mar	380	16-May	324
		25-Mar	301	14-Mar	324			5-Apr	430	13-Mar	348	25-Apr	287	25-Mar	413			5-Apr	274	1-Apr	327	17-May	297
		26-Mar	290	15-Mar	307			6-Apr	419	14-Mar	306	26-Apr	250	26-Mar	349	12-Apr	304	6-Apr	235	2-Apr	366	18-May	241
		27-Mar	309	16-Mar	313			7-Apr	382	15-Mar	283	27-Apr	254	27-Mar	308	13-Apr	314			3-Apr	481		
		28-Mar	312	17-Mar	292			8-Apr	344	16-Mar	247			28-Mar	276	14-Apr	260	14-Apr	427	4-Apr	433	7-Jun	460
		29-Mar	323	18-Mar	260			9-Apr	291					29-Mar	245			15-Apr	476	5-Apr	313	8-Jun	853
		30-Mar	356	19-Mar	236			10-Apr	247	19-Mar	232			30-Mar	335			16-Apr	376	6-Apr	307	9-Jun	622
		31-Mar	338							20-Mar	320			31-Mar	645			17-Apr	319	7-Apr	251	10-Jun	490
		1-Apr	330	22-Mar	278			13-Apr	258	21-Mar	296			1-Apr	504			18-Apr	254	8-Apr	247	11-Jun	430
		2-Apr	480	23-Mar	393			14-Apr	287	22-Mar	279			2-Apr	396							12-Jun	356
		3-Apr	422	24-Mar	338			15-Apr	233	23-Mar	264			3-Apr	334							13-Jun	296
		4-Apr	334	25-Mar	306					24-Mar	244			4-Apr	288							14-Jun	234
		5-Apr	282	26-Mar	279			19-Apr	334					5-Apr	248								
		6-Apr	253	27-Mar	253			20-Apr	413	7-May	277			6-Apr	218								
				28-Mar	266			21-Apr	328	8-May	268			7-Apr	206								
		13-Apr	247	29-Mar	300			22-Apr	266	9-May	226			8-Apr	215								
		14-Apr	241	30-Mar	312					10-May	293			9-Apr	237								
				31-Mar	271					11-May	440												
				1-Apr	238					12-May	399			18-Jun	269								
										13-May	329			19-Jun	253								
										14-May	284												
										15-May	245												
										14-Jun	1070												
										15-Jun	1110												
										16-Jun	1050												
										17-Jun	818												
										18-Jun	614												
										19-Jun	514												
										20-Jun	450												

Table 23. Flows greater than 350 cfs.

Flows greater than 350 cfs (highlighted)																							
1990		1993		1994		1996		1997		1998		2000		2001		2003		2004		2005		2006	
dates	flows	dates	flows	dates	flows	dates	flows	dates	flows	dates	flows	dates	flows	dates	flows	dates	flows	dates	flows	dates	flows	dates	flows
4-Apr	240	18-Mar	232	11-Mar	640	17-Apr	345	2-Apr	256	10-Mar	621	22-Apr	278	22-Mar	409	31-Mar	371	2-Apr	349	29-Mar	711	14-May	276
5-Apr	256	19-Mar	250	12-Mar	450	18-Apr	308	3-Apr	332	11-Mar	551	23-Apr	443	23-Mar	648	1-Apr	304	3-Apr	305	30-Mar	558	15-May	369
				13-Mar	353	19-Apr	254	4-Apr	351	12-Mar	422	24-Apr	348	24-Mar	501	2-Apr	259	4-Apr	266	31-Mar	380	16-May	324
		25-Mar	301	14-Mar	324			5-Apr	430	13-Mar	348	25-Apr	287	25-Mar	413			5-Apr	274	1-Apr	327	17-May	297
		26-Mar	290	15-Mar	307			6-Apr	419	14-Mar	306	26-Apr	250	26-Mar	349	12-Apr	304	6-Apr	235	2-Apr	366	18-May	241
		27-Mar	309	16-Mar	313			7-Apr	382	15-Mar	283	27-Apr	254	27-Mar	308	13-Apr	314			3-Apr	481		
		28-Mar	312	17-Mar	292			8-Apr	344	16-Mar	247			28-Mar	276	14-Apr	260	14-Apr	427	4-Apr	433	7-Jun	460
		29-Mar	323	18-Mar	260			9-Apr	291					29-Mar	245			15-Apr	476	5-Apr	313	8-Jun	853
		30-Mar	356	19-Mar	236			10-Apr	247	19-Mar	232			30-Mar	335			16-Apr	376	6-Apr	307	9-Jun	622
		31-Mar	338							20-Mar	320			31-Mar	645			17-Apr	319	7-Apr	251	10-Jun	490
		1-Apr	330	22-Mar	278			13-Apr	258	21-Mar	296			1-Apr	504			18-Apr	254	8-Apr	247	11-Jun	430
		2-Apr	480	23-Mar	393			14-Apr	287	22-Mar	279			2-Apr	396							12-Jun	356
		3-Apr	422	24-Mar	338			15-Apr	233	23-Mar	264			3-Apr	334							13-Jun	296
		4-Apr	334	25-Mar	306					24-Mar	244			4-Apr	288							14-Jun	234
		5-Apr	282	26-Mar	279			19-Apr	334					5-Apr	248								
		6-Apr	253	27-Mar	253			20-Apr	413	7-May	277			6-Apr	218								
				28-Mar	266			21-Apr	328	8-May	268			7-Apr	206								
		13-Apr	247	29-Mar	300			22-Apr	266	9-May	226			8-Apr	215								
		14-Apr	241	30-Mar	312					10-May	293			9-Apr	237								
				31-Mar	271					11-May	440												
				1-Apr	238					12-May	399			18-Jun	269								
										13-May	329			19-Jun	253								
										14-May	284												
										15-May	245												
										14-Jun	1070												
										15-Jun	1110												
										16-Jun	1050												
										17-Jun	818												
										18-Jun	614												
										19-Jun	514												
										20-Jun	450												

Table 24. Flows less than 33 cfs.

Flows less than 33 cfs.																							
1991		1992		1993		1994		1995		1996		1997		1998		2001		2004		2005		2006	
date	flow	date	flow	date	flow	date	flow	date	flow	date	flow	date	flow	date	flow	date	flow	date	flow	date	flow	date	flow
25-May	26	24-May	27	29-May	26	1-Jun	26	27-May	29	15-Jun	27	5-Jun	26	13-May	26	11-May	26	13-Jun	26	20-Jun	26	3-Apr	27
26-May	27	25-May	25	30-May	26	2-Jun	27	28-May	22	16-Jun	24	6-Jun	26	14-May	27	12-May	27	14-Jun	25			14-Jun	25
27-May	23	26-May	23	31-May	23	3-Jun	27	29-May	20	17-Jun	22	7-Jun	24	15-May	27	13-May	25	15-Jun	23			19-Apr	25
28-May	23	27-May	23			4-Jun	23	30-May	24	18-Jun	20	8-Jun	23	16-May	28	14-May	24	16-Jun	21			20-Apr	25
29-May	23	28-May	22	4-Jun	29	5-Jun	19	31-May	26	19-Jun	17	9-Jun	21	17-May	23	15-May	23	17-Jun	20			21-Apr	23
30-May	22	29-May	22	5-Jun	26	6-Jun	18	1-Jun	23	20-Jun	17	10-Jun	20	18-May	22	16-May	22	18-Jun	18			22-Apr	22
31-May	27	30-May	22	6-Jun	27	7-Jun	19	2-Jun	21			11-Jun	18	19-May	22	17-May	22	19-Jun	17			23-Apr	23
1-Jun	27	31-May	21	7-Jun	29	8-Jun	21	3-Jun	17			12-Jun	17			18-May	22	20-Jun	20				
2-Jun	23			8-Jun	25	9-Jun	19	4-Jun	18			13-Jun	15	3-Jun	27	19-May	22						
3-Jun	19	17-Jun	26	9-Jun	19	10-Jun	17	5-Jun	17			14-Jun	15	4-Jun	24	20-May	21						
4-Jun	20	18-Jun	22	10-Jun	20	11-Jun	14	6-Jun	15			15-Jun	13	5-Jun	21	21-May	20						
5-Jun	22	19-Jun	20	11-Jun	19	12-Jun	12	7-Jun	25			16-Jun	12	6-Jun	18	22-May	21						
6-Jun	23	20-Jun	19	12-Jun	17	13-Jun	12					17-Jun	11	7-Jun	17	23-May	25						
7-Jun	22			13-Jun	15	14-Jun	15	20-Jun	29			18-Jun	10	8-Jun	15								
8-Jun	19			14-Jun	14							19-Jun	11	9-Jun	13	18-Jun	26						
9-Jun	17			15-Jun	12	20-Jun	25					20-Jun	11	10-Jun	11								
10-Jun	14			16-Jun	12									11-Jun	10								
11-Jun	12			17-Jun	14									12-Jun	9								
12-Jun	12			18-Jun	10									13-Jun	8.4								
13-Jun	15			19-Jun	8.8									14-Jun	7.9								
14-Jun	14			20-Jun	7.1									15-Jun	7.5								
15-Jun	11													16-Jun	7.5								
16-Jun	9.7													17-Jun	6.8								
17-Jun	8.8													18-Jun	6.6								
18-Jun	8.2													19-Jun	6.1								
19-Jun	7.4													20-Jun	5.5								
20-Jun	7.2																						

Table 25. Flows Less than 15 cfs.

Flows less than 15 cfs (highlighted)																							
1991		1992		1993		1994		1995		1996		1997		1998		2001		2004		2005		2006	
date	flow	date	flow	date	flow	date	flow	date	flow	date	flow	date	flow	date	flow	date	flow	date	flow	date	flow	date	flow
25-May	29	24-May	27	29-May	28	1-Jun	28	27-May	29	15-Jun	27	5-Jun	28	13-May	28	11-May	29	13-Jun	28	20-Jun	28	3-Apr	27
26-May	27	25-May	25	30-May	28	2-Jun	27	28-May	22	16-Jun	24	6-Jun	28	14-May	27	12-May	27	14-Jun	28				
27-May	23	28-May	23	31-May	23	3-Jun	27	29-May	20	17-Jun	22	7-Jun	24	15-May	27	13-May	25	15-Jun	23			19-Apr	25
28-May	23	27-May	23			4-Jun	23	30-May	24	18-Jun	20	8-Jun	23	16-May	28	14-May	24	16-Jun	21			20-Apr	25
29-May	23	25-May	22	4-Jun	29	5-Jun	19	31-May	28	19-Jun	17	9-Jun	21	17-May	23	15-May	23	17-Jun	20			21-Apr	23
30-May	22	29-May	22	5-Jun	26	6-Jun	18	1-Jun	23	20-Jun	17	10-Jun	20	18-May	22	16-May	22	18-Jun	18			22-Apr	22
31-May	27	30-May	22	6-Jun	27	7-Jun	19	2-Jun	21			11-Jun	18	19-May	22	17-May	22	19-Jun	17			23-Apr	23
1-Jun	27	31-May	21	7-Jun	29	8-Jun	21	3-Jun	17			12-Jun	17			18-May	22	20-Jun	20				
2-Jun	23			8-Jun	25	9-Jun	19	4-Jun	18			13-Jun	18	2-Jun	27	19-May	22						
3-Jun	19	17-Jun	28	9-Jun	19	10-Jun	17	5-Jun	17			14-Jun	18	4-Jun	24	20-May	21						
4-Jun	20	18-Jun	22	10-Jun	20	11-Jun	14	6-Jun	18			15-Jun	13	5-Jun	21	21-May	20						
5-Jun	22	19-Jun	20	11-Jun	19	12-Jun	12	7-Jun	25			16-Jun	12	6-Jun	18	22-May	21						
6-Jun	23	20-Jun	19	12-Jun	17	13-Jun	12					17-Jun	11	7-Jun	17	23-May	28						
7-Jun	22			13-Jun	18	14-Jun	15	20-Jun	29			18-Jun	10	8-Jun	18								
8-Jun	19			14-Jun	14							19-Jun	11	9-Jun	13	16-Jun	28						
9-Jun	17			15-Jun	12	20-Jun	25					20-Jun	11	10-Jun	11								
10-Jun	14			16-Jun	12									11-Jun	10								
11-Jun	13			17-Jun	14									12-Jun	9								
12-Jun	13			18-Jun	10									13-Jun	8.4								
13-Jun	15			19-Jun	8.8									14-Jun	7.9								
14-Jun	14			20-Jun	7.1									15-Jun	7.5								
15-Jun	11													16-Jun	7.5								
16-Jun	9.7													17-Jun	6.8								
17-Jun	8.8													18-Jun	6.8								
18-Jun	8.2													19-Jun	6.1								
19-Jun	7.4													20-Jun	5.8								
20-Jun	7.2																						



## Appendix C. Hydraulic Analysis.

Table 26. Tail water conditions

<b>Q low (10 cfs)</b>	<b>Q average (100 cfs)</b>	<b>Q high (2000 cfs)</b>	<b>Q PMF (8000 cfs)</b>
channel width (b)= 20	channel width (b)= 100	channel width (b)= 180	channel width (b)= 280
channel length = 4000	channel length = 4000	channel length = 4000	channel length = 4000
let Q low = 10 cfs 10	let Q avg = 100 cfs 100	let Q high = 2000 cfs 2000	let Q high = 2000 cfs 8000
flow per unit width, q 0.5	flow per unit width, q 1	flow per unit width, q 11.11111	flow per unit width, q 28.57143
<b>critical depth, yc= 0.198013</b>	<b>critical depth, yc= 0.314327</b>	<b>critical depth, yc= 1.565139</b>	<b>critical depth, yc= 2.937668</b>
velocity v= 1.983345	velocity v= 2.629401	velocity v= 6.856855	velocity v= 9.993732
<b><u>Manning EQN</u></b>	<b><u>Manning EQN</u></b>	<b><u>Manning EQN</u></b>	<b><u>Manning EQN</u></b>
q= 0.50377	q= 1.001802	q= 11.11496	q= 28.57208
n= 0.04	n= 0.04	n= 0.04	n= 0.04
<b>yn= 0.254</b>	<b>yn= 0.381</b>	<b>yn= 1.621</b>	<b>yn= 2.859</b>
S0= 0.00246	S0= 0.00246	S0= 0.00246	S0= 0.00246
Q= 10.07539	Q= 100.1802	Q= 2000.693	Q= 8000.182
<b><u>Froude # (Fr)</u></b>	<b><u>Froude # (Fr)</u></b>	<b><u>Froude # (Fr)</u></b>	<b><u>Froude # (Fr)</u></b>
0.492441	0.462954	0.362446	0.32948
<b><u>Flow Profile</u></b>	<b><u>Flow Profile</u></b>	<b><u>Flow Profile</u></b>	<b><u>Flow Profile</u></b>
mild channel (yn>yc)	mild channel (yn>yc)	mild channel (yn>yc)	mild channel (yn>yc)
subcritical flow (Fr>1)	subcritical flow (Fr>1)	subcritical flow (Fr>1)	subcritical flow (Fr>1)
M1 or M2 curve	M1 or M2 curve	M1 or M2 curve	M1 or M2 curve



Table 27. Spillway Crest Conditions, with Spillway Equation.

CONDITIONS AT CREST			
<u>Q average</u>	<u>Q high</u>	<u>Q low</u>	<u>Q PMF</u>
Ha=Hs (ft) 0.45	Ha=Hs (ft) 3.166	Ha=Hs (ft) 0.1	Ha=Hs (ft) 7.975311
Cd= 3.271429	Cd= 3.551429	Cd= 3.231429	Cd= 3.562857
L= 100	L= 100	L= 100	L= 100
Q= <b>98.75435</b>	Q= <b>2000.642</b>	Q= <b>10.21867</b>	Q= <b>8024.534</b>
			approach velocity 17.9
H (ft)= 0.45	H (ft)= 2.9	H (ft)= 0.1	H (ft)= 3
p (ft)= 3.5	p (ft)= 3.5	p (ft)= 3.5	p (ft)= 3.5
p/H= 7.77778	p/H= 1.105496	p/H= 35	p/H= 0.438854

Table 28. Spillway Toe Conditions.

CONDITIONS AT TOE							
Q average		Q high		Q low		Q PMF	
channel width (b)= 100 ft	100	channel width (b)= 100 ft	100	channel width (b)= 100 ft	100	channel width (b)= 100 ft	100
channel length = 40ft	4	channel length = 40ft	4	channel length = 40ft	4	channel length = 40ft	4
Q (cfs)=	98.75435	Q (cfs)=	2000.642	Q (cfs)=	10.21867	Q (cfs)=	8024.534
flow per unit width, q =	0.987543	flow per unit width, q =	20.00642	flow per unit width, q =	0.102187	flow per unit width, q =	80.24534
critical depth, yc=	0.311711	critical depth, yc=	2.316475	critical depth, yc=	0.068703	critical depth, yc=	5.847828
<u>Manning Equation</u>		<u>Manning Equation</u>		<u>Manning Equation</u>		<u>Manning Equation</u>	
q=	0.997595	q=	20.05017	q=	0.099033	q=	80.13726
n=	0.013	n=	0.013	n=	0.013	n=	0.013
yn=	0.06	yn=	0.364	yn=	0.015	yn=	.839
S0=	0.85	S0=	0.85	S0=	0.85	S0=	0.85
Q=	99.75946	Q=	2005.017	Q=	9.903328	Q=	8013.726
V=	16.62658	V=	55.08288	V=	6.602218	V=	95.51521
<u>Froude # (Fr)</u>		<u>Froude # (Fr)</u>		<u>Froude # (Fr)</u>		<u>Froude # (Fr)</u>	
2.933579		2.167852		3.697187		1.880301	
<u>Flow Profile</u>		<u>Flow Profile</u>		<u>Flow Profile</u>		<u>Flow Profile</u>	
steep channel (yn<yc)		steep channel (yn<yc)		steep channel (yn<yc)		steep channel (yn<yc)	
supercritical (Fr>1)		supercritical (Fr>1)		supercritical (Fr>1)		supercritical (Fr>1)	

## Spillway Crest Conditions Under All Analyzed Flowrates

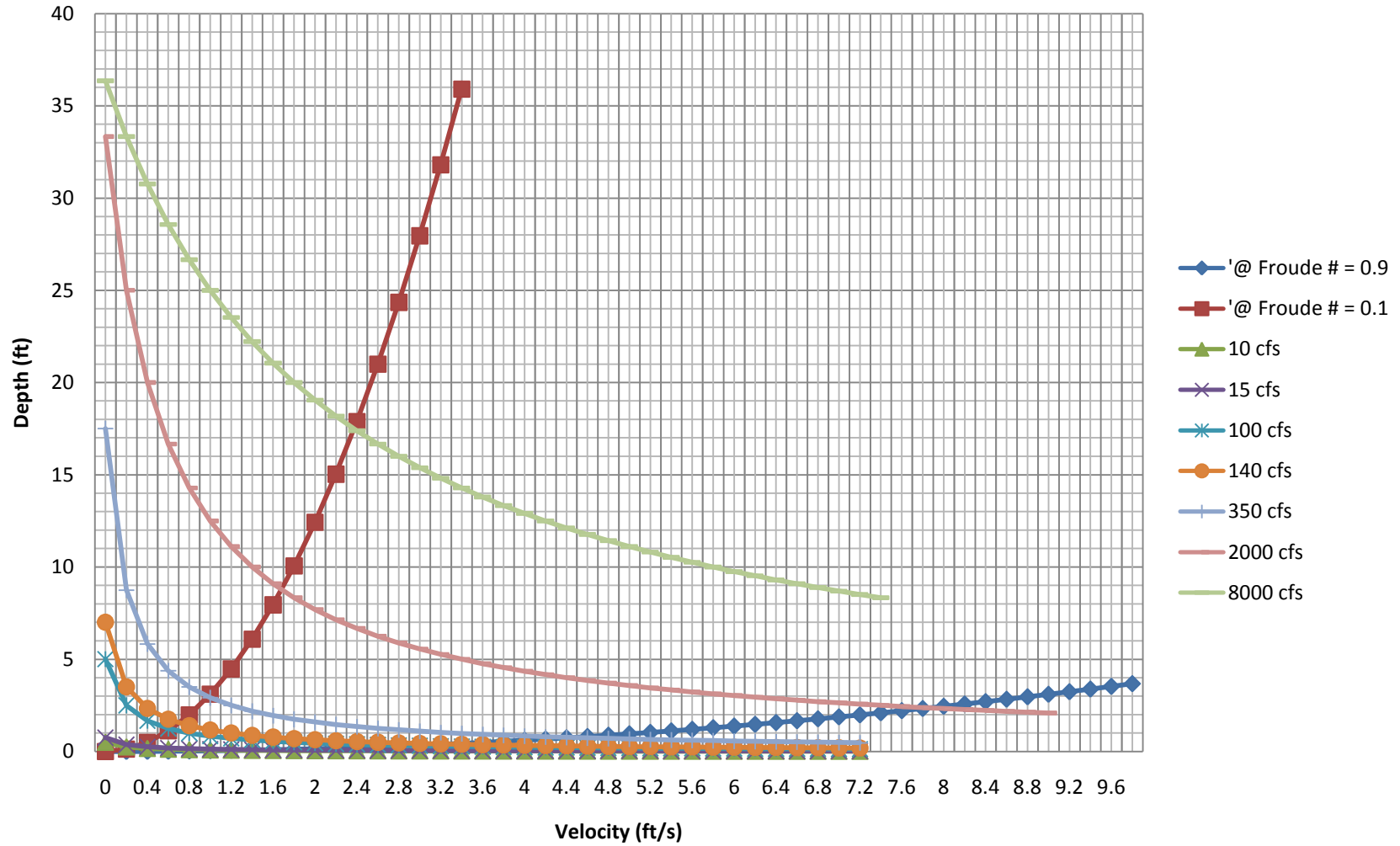

Figure 66. Spillway Crest Conditions, under all analyzed flow rates.

## Spillway Crest Conditions Under Analyzed Flowrates <350 cfs

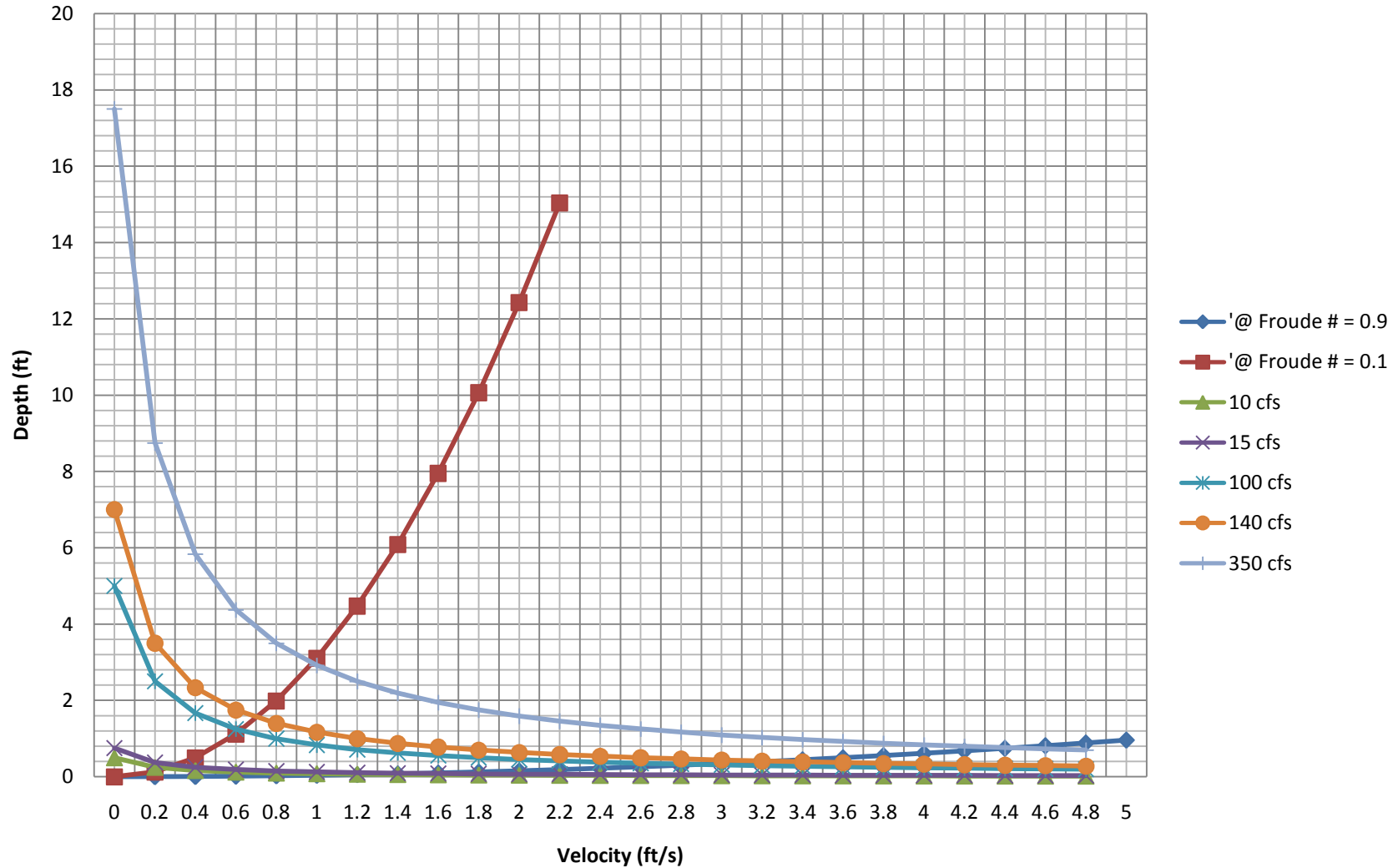

Figure 67. Spillway Crest Conditions, flow rates <350 cfs

## Appendix D. Plans

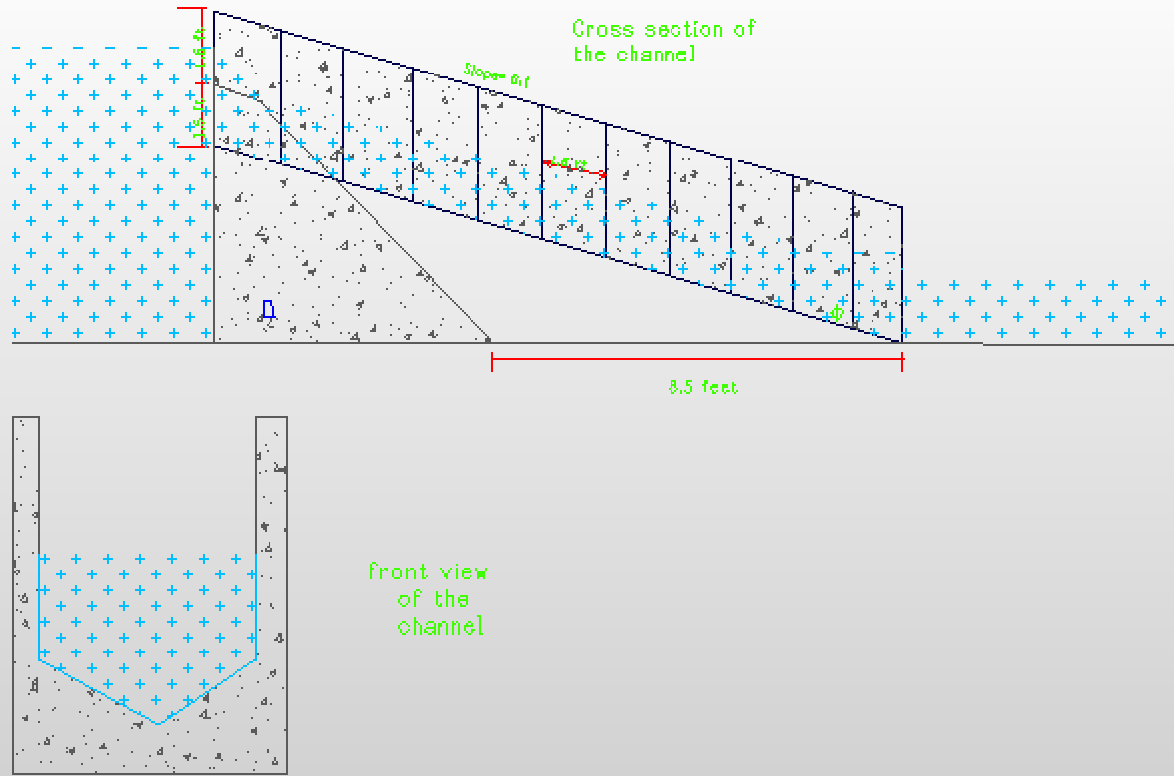

Figure 68. Fishway plan and cross sectional views.

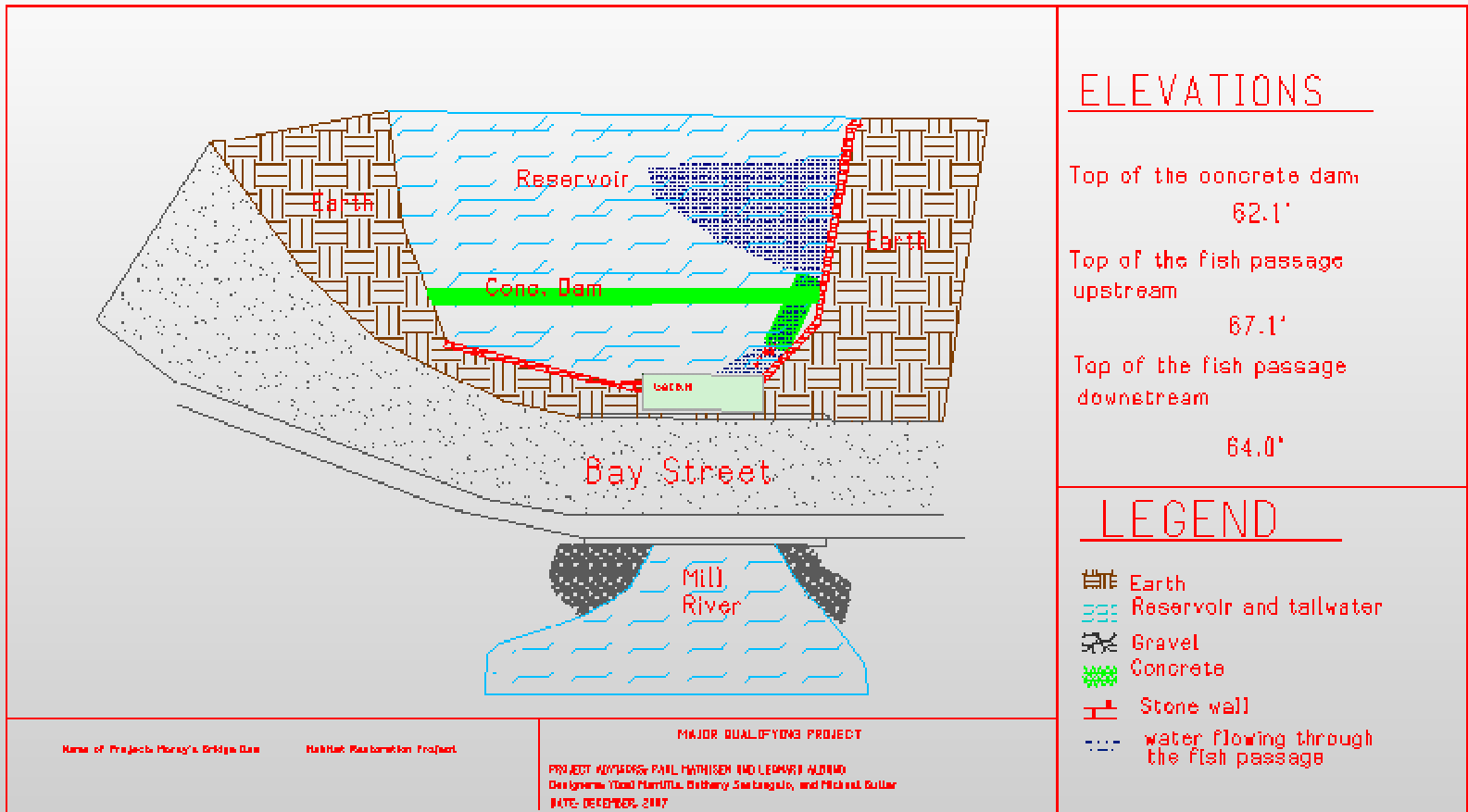
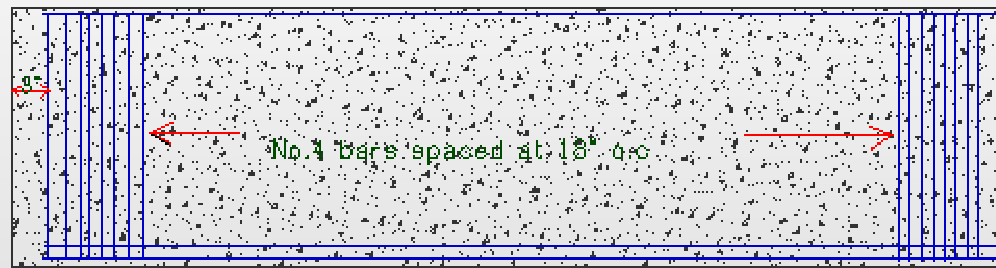
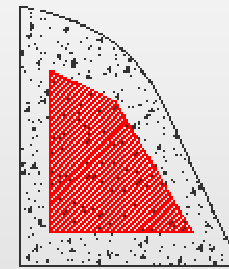

Figure 69. Proposed Site Plan.



L=100ft



cross-section  
of the dam

Figure 70. Dam reinforcement.

## Appendix E. Cost Estimating

Table 29. Cost with simultaneous construction of Fishway and Dam. Con't on next page.

DIVISIONS	COST/UNIT	No. of Units	Unit	TOTAL
<b>DIVISION 1:GENERAL REQUIREMENTS</b>				
<b>SUBDIVISION</b>				
<b>1310 PROJCT MANAGEMENT/ COORDINATION</b>				
620 Overhead & Profit(25%)				\$25,649.67
700 Field Personnel	4935	8	weekly	\$39,480.00
<b>1320 PROGRESS DOCUMENTATION</b>				
200 Scheduling	1%			\$1,025.99
200 Cost Control	0.08%			\$820.79
<b>1321 CONSTRUCTION PHOTOS</b>				
500 Photograph	250	1		\$250.00
<b>1450 QUALITY CONTROL</b>				
500 Testing & Inspectional Service	1,868	1		\$1,868.00
<b>1590 EQUIPMENT RENTAL</b>				\$0.00
100 Restrooms	159	45	per day	\$7,155.00
100 Concrete pump	200	2	per day	\$400.00
100 Manual Gas For Concrete	35	2	day	\$70.00
100 Vibrators	10.65	2	day	\$21.30
100 Concrete Batch Truck	670	2	day	\$1,340.00
200 Earthwork Equipment Rental	1,200	1		\$1,200.00
400 General Equipment	500	45	day	\$22,500.00
<b>1560 BARRIERS &amp; ENCLOSURES</b>				
250 Temporary Fencing	6.75	250	Linear ft	\$1,687.50
<b>1580 PROJECT SIGNS</b>				
700 Signs	16.4	30	sf	\$492.00
<b>DIVISION 2: SITE CONSTRUCTION</b>				
<b>SUBDIVISION</b>				
<b>2110 HAZARD REMOVAL &amp; HANDLING</b>				
300 Heavy Sludge or Dry Vacuumable Material	100	72	hr	\$7,200.00
<b>2240 DEWATERING</b>				
500 Dewatering	7.85	111	cy	\$871.35
<b>2260 EXCAVATION SUPPORT/ PROTECTION</b>				
200 Coffe Dams	19.8	350	sf	\$6,930.00
<b>2310 GRADING</b>				



100 Finish Grading	2.37	2400.03	sy	\$5,688.07
<b>2315 EXCAVATION &amp; FILL</b>				
110 Backfill, General	15.25		l.c.y	
<b>DIVISION 3 CONCRETE</b>				
Mass concrete			cy	
Fish Ladder	75	4.7300591		\$354.75
Dam	75	1050.0131		\$78,750.98
<b>DIVISION Metals</b>				\$0.00
Reinforcement			lb	\$0.00
Fish Ladder	0.45	450		\$202.50
Dam	0.45	5780		\$2,601.00
<b>Total</b>				<b>\$206,558.90</b>

Table 30. Cost of Dam Construction.

DIVISIONS	COST/UNIT	No of Units	Unit	TOTAL
<b>DIVISION 1: GENERAL REQUIREMENTS</b>				
<b>SUBDIVISION</b>				
<b>1310 PROJCT MANAGEMENT/ COORDINATION</b>				
620 Overhead & Profit(25%)				25559.389
700 Field Personel	4935	6	weekly	29610
<b>1320 PROGRESS DOCUMENTATION</b>				
200 Scheduling	1%			1022.3756
200 Cost Control	0.08%			817.90045
<b>1321 CONSTRUCTION PHOTOS</b>				
500 Photograph	250	1		250
<b>1450 QUALITY CONTROL</b>				
500 Testing & Inspectional Servise	1,868	1		1868
<b>1590 EQUIPMENT RENTAL</b>				
100 Restrooms	159	45	per day	7155
100 Concrete pump	200	2	per day	400
100 Manual Gas For Concrete	35	2	day	70
100 Vibrators	10.65	2	day	21.3
100 Concrete Batch Truck	670	2	day	1340
200 Earthwork Equipment Rental	1,200			0
400 General Equipment	500	45	day	22500

<b>1560 BARRIERS &amp; ENCLOSURES</b>				0
250 Temporary Fencing	6.75	250	Linear ft	1687.5
<b>1580 PROJECT SIGNS</b>				0
700 Signs	16.4	30	sf	492
<b>DIVISION 2: SITE CONSTRUCTION</b>				0
<b>SUBDIVISION</b>				0
<b>2110 HAZARD REMOVAL &amp; HANDLING</b>				0
300 Heavy Sludge or Dry Vacuumable Material	100	72	hr	7200
<b>2240 DEWATERING</b>				0
500 Dewatering	7.85		cy	0
<b>2260 EXCAVATION SUPPORT/ PROTECTION</b>				0
200 Cofferdams	19.8	350	sf	6930
<b>2310 GRADING</b>				0
100 Finish Grading	2.37	2400.03	sy	5688.0711
<b>2315 EXCAVATION &amp; FILL</b>				
110 Backfill, General	15.25	70	l.c.y	1067.5
<b>DIVISION 3 CONCRETE</b>				
mass concrete				
Dam	75	1050.0131	cy	78750.985
<b>DIVISION Metals</b>				
reinforcement				
Dam	0.45	5780	lb	2601
<b>Total</b>				195031.02

Table 31. Cost of Fishway Construction.

DIVISIONS	COST/UNIT	No of Units	Unit	TOTAL
<b>DIVISION 1: GENERAL REQUIREMENTS</b>				
<b>SUBDIVISION</b>				
<b>1310 PROJCT MANAGEMENT/ COORDINATION</b>				
620 Overhead & Profit(25%)	0			13077.181
700 Field Personnel	4935	6	weekly	29610
<b>1320 PROGRESS DOCUMENTATION</b>				
200 Scheduling	1%			523.08725
200 Cost Control	0.80%			418.4698
<b>1321 CONSTRUCTION PHOTOS</b>				

500 Photograph	250	1		250
<b>1450 QUALITY CONTROL</b>				
500 Testing & Inspectional Service	1,868	1		1868
<b>1590 EQUIPMENT RENTAL</b>				
100 Restrooms	159	30	per day	4770
200 Earthwork Equipment Rental	1,200	7	days	8400
400 General Equipment	500	45	day	22500
<b>1560 BARRIERS &amp; ENCLOSURES</b>				
250 Temporary Fencing	6.75	250	Linear ft	1687.5
<b>1580 PROJECT SIGNS</b>				
700 Signs	16.4	30	sf	492
<b>DIVISION 2: SITE CONSTRUCTION</b>				
<b>SUBDIVISION</b>				
<b>2110 HAZARD REMOVAL &amp; HANDLING</b>				
300 Heavy Sludge or Dry Vacuumable Material	100	72	hr	7200
<b>2240 DEWATERING</b>				
500 Dewatering	7.85	111	cy	871.35
<b>2260 EXCAVATION SUPPORT/ PROTECTION</b>				
<b>2310 GRADING</b>				
100 Finish Grading	2.37	2400.03	sy	5688.0711
<b>2315 EXCAVATION &amp; FILL</b>				
110 Backfill, General	15.25	14	l.c.y	213.5
<b>DIVISION 3 CONCRETE</b>				
pre cast Fish Ladder	60	4.7300591	cy	283.80355
<b>DIVISION Metals</b>				
reinforcement Fish Ladder	0.45	450	lb	202.5
Dam				
<b>Total</b>				98055.463

LDA-0807

PPM-0807

**Major Qualifying Project Report Proposal:**

submitted to the Faculty

of the

WORCESTER POLYTECHNIC INSTITUTE

in partial fulfillment of the requirements for the

Degree of Bachelor of Science

by

---

Yisel Mantilla

---

Bethany Santangelo

---

Michael Butler

Date: December 20, 2007

Approved:

---

Professor Leonard Albano, Major Advisor

---

Professor Paul P Mathisen, Major Advisor

# 1 INTRODUCTION

Lakes, rivers and streams have been extremely important in the civil engineering field; they are all interrelated, impacting the ecology and the economy of the society in a very direct manner. The health of river systems has a direct impact on the surrounding communities economically, socially, and in a public safety sense. Many communities are founded on river ways acting as navigational routes or fishing as a livelihood. Socially, healthy river and lake systems can also provide the communities with recreational activities, food, transportation, and the threat of flooding. Rivers can also provide society with energy, as is the case with hydroelectric dams.

As a consequence of the great importance of rivers, lakes and streams; engineers, scientists and governmental agencies such as Massachusetts Department of Fish and Wildlife have been paying special attention to restoration projects with the goals of habitat improvement, water quality, hydrological purposes, and recreational interests; all of them contributing to the economy.

Some of the most relevant river or stream projects include dams, which act as barriers to the flow of rivers. This barrier can provide energy through turbines, flood protection by creating storage space upstream for excess water in wet seasons, and can also act as barriers to the continuity of natural habitats.

Many dams were constructed for energy purposes during the industrial revolution. These dams are currently aging, and the failure of any of these dams could have negative consequences downstream such as water contamination, flooding and degradation of the zone's ecology. Of course, the failure of any of these dams could also restore continuity to the surrounding aquatic habitats. In the case of an aging dam close to failure, a restoration project is necessary to restore the public safety value of the dam in its ability to hold back flood waters, and install a structure to allow native aquatic species to pass.

One example of this type of project is Mill River Habitat Restoration Project, which includes Reed and Barton Dams, Whittenton Dam and Morey's Bridge Dam restoration at Taunton city in Massachusetts. The fundamental goal of this restoration project is to restore 37 miles of riverine and lake habitat and to provide a safe environment to the city of Taunton. The Whittenton Dam failure in 2005 and its consequences called national attention and gave place to a feasibility study for this restoration project in the Spring of 2007. The restoration project is divided in three subprojects consisting of the feasibility of removing Reed and Barton and Whittenton Dams to increase fish passage, and to improve the safety of Morey's Bridge Dam while incorporating a fish passage structure into the restoration design.

## 1.1 Capstone Design Process

This project focuses on the reconstruction of Morey's Bridge Dam, with a fish passage designed to be built into the dam. Environmental and structural design analysis of the existing conditions at the site will be completed to reach a design that addressed the needs of the project as stated by the Capstone Design requirements of the American Society of Civil Engineers. The capstone design process requires that the final design has attributes that appeal to the economic, social,

and environmental needs of the community, while considering the impact of engineering ethics, constructability, and costs of the project.

This project will meet the requirements of the capstone design process by analyzing existing environmental and structural conditions of the site, applying hydrologic and hydraulic analysis to define the maximum design requirements, and creating a structure that fits those requirements. A cost estimate and constructability issues will be addressed to create a design that is functional and reasonable for the requirements of the site.

## 1.2 Mill River Geography

Mill River contains a muddy shoreline of about 37 miles and runs from the 266- acre Lake Sabbatia to The Taunton River close to the Weir Village. It connects with Winneconne Pond and The Snake River, which is connected with the largest freshwater wetland in Massachusetts, Hock mock Swamp. Mill River contains four dams, Taunton State Hospital Dam, Whittenton Mill Dam, Reed and Barton Dam and Morey's Bridge Dam. All these dams had gained special and national attention after the Whittenton Mill Dam failure in 2005. The wooded Whittenton Mill Dam was 173 years old at the time of failure, the same age of the other three dams. According to the feasibility study started in spring of 2007, the Taunton State Hospital and Reed and Barton Dams are no longer serving as barriers for fish passage, Whittenton Dam condition ranges from fair to poor and it remains as a barrier for fish passage, and Morey's Bridge Dam, which is the one included in our project, was classified as a high hazard due to the condition of the spillway gates. Although all these dams are part of Mill River restoration project, we will emphasize on the analysis and designs of the Morey's Bridge Dam, its spillway and a correspondent fish passage.

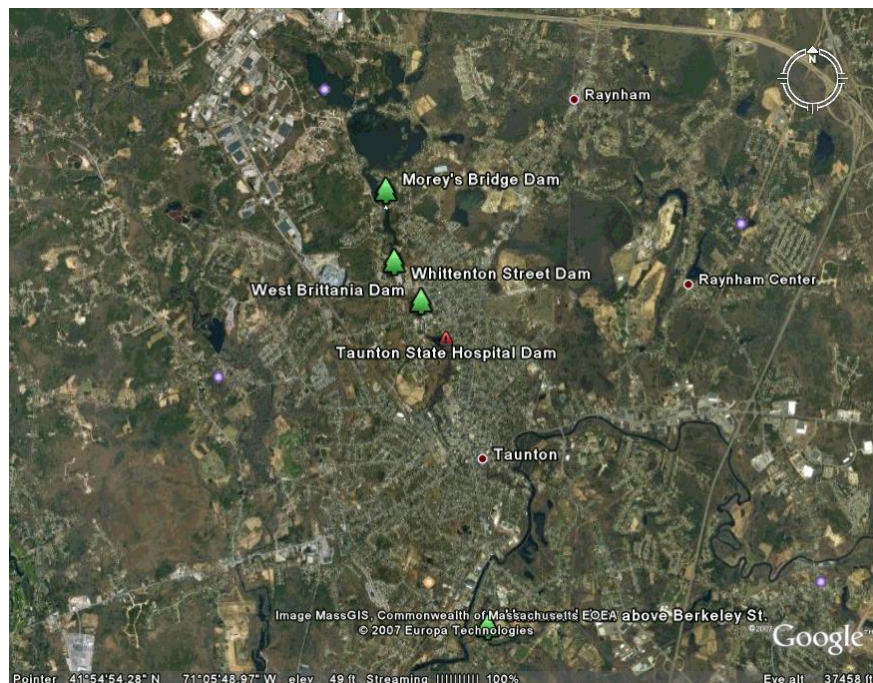

Figure 71. Dams located along the Mill River.

## **2 BACKGROUND**

A review of the purposes of dam structures, and the environmental implications of these structures is a starting point for the analysis. It is necessary to complete a review of dam structures to find a structure that fits the spatial limitations of the site, the economic limitations of the community, and the environmental limitations of the surrounding ecosystem and geography.

### **2.1 General Purpose of Dams.**

The construction of a dam is usually considered in rivers to provide a water supply for cities, towns, mining sites, or irrigation of crops, to generate electricity, and to control or moderate floods. The most typical design of a dam consists of a solid wall across the river to block the flow of water and form a reservoir upstream to provide both drinking water for later use and storage space in the event of a flood. Since the main purpose of this wall is to retain water, it should be impermeable as well as its foundation to avoid the water leakage downstream.

As any other structure, dams should be stable. They should be designed to sufficiently support their own weight, the water pressure from upstream, earthquake forces, and sediment loads. They must also contain a way of releasing water in controlled quantities. Depending on the specific characteristics and purposes of the dam, the water may be released into pipelines or into the river downstream by outlet valves. However, most of the times these outlet valves are not sufficient to release the large volume of flood water that can be held back by a dam, thus it is necessary to install a spillway, which is usually an open channel to carry the flood water around the dam. Small dams may not have outlet works. These dams commonly have a spillway at a set elevation, where a small amount of water is to pass through the spillway naturally, but have sufficient space to pass volumes of water under flood conditions.

#### **2.1.1 Types of Dams.**

There exist a diverse number of dams, each type with one or more specific function and structural characteristics. Examples of the different types of dam are: earthen embankment, buttress dams, diverse arch dams, rock fill dams, hydraulic fill dams, and barrages Dams. For our project, we will focus in concrete dams with the possibility of some earthen embankment. This is because of the limited area of the site and the small scale of this project.

Embankment dams can be made of rock, earth, or both. Spillways in these types of dams have to be separate from the dam structure to prevent erosion. This type of dam is one of the most suitable for soft variable sedimentary strata. Concrete dams are made out of concrete. Spillways on concrete dams can be part of the dam structure, where either a gate controls the volume of water passing through the spillway, or the spillway is set at a certain elevation and water is constantly flowing over the dam and downstream. This type of design has limited flood control, but fits well into small sites and is suitable for site where floodplain downstream has storage space to be used during flood events.

## 2.1.2 Forces on Embankment Dams.

The most important force acting on an embankment dam is the force of the water and uplift forces and its own weight, which will vary according to the type of soil or material used. However, there are some other forces acting on the structure such as internal hydrostatic pressure, silt pressure, ice and wave loads in the upstream sides, earthquake loads, settlement, and the weight of any other structure on top of the dam.

## 2.1.3 Forces in Concrete Dams.

Similarly as in embankment dams, the main forces acting on the concrete dam are the pressure of water, which will be greater the deeper the water is, the weight on the concrete, and the uplift forces. In this case we also have some other forces like the ones we mentioned previously. The following figure illustrates the forces acting on a gravity concrete dam.

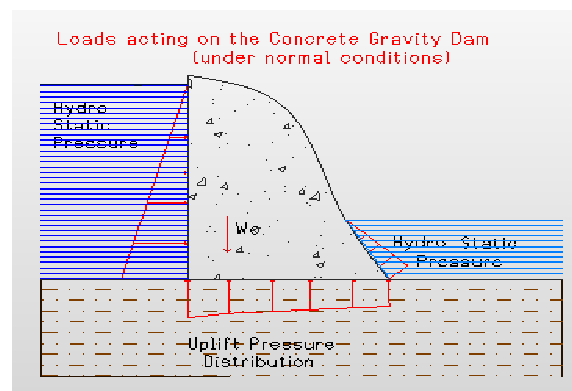

Figure 72. Forces acting on concrete dams.

## 2.1.4 Forces Combination for Structural Analysis of Dams

There are some important loads combination involved in the structural analysis of a structure such dams. The major combinations of these loadings are:

Case 1: Dead Loads effects + temperature changes effects+ shrinkage in concrete effect.

Case 2: Water pressure effect + reservoir load on the valley floor

Case 3: Case 1 or Case 2 + Earthquake Effects.

## 2.1.5 Settlements

For structural design considerations only the highest section of the dam is considered in settlement analysis and calculations. Settlement depends on the fill and consolidation stages for the entire height of the structure.

### Consolidation Settlement

Consolidation settlement occurs when the soils particles are pressed together increasing the effective stress of the soil. For this analysis, we considered the soil to be 100% saturated.

### Consolidation Status in the field



This classification is made comparing the pre-consolidation stress with the initial vertical effective stress of the specific soil.

**Normally Consolidated Soils:** if the pre-consolidation stress value is very approximate or equal to the initial vertical effective stress value of the specific soil.

**Over consolidated Soils:** if the pre-consolidation stress value is greater than the initial vertical effective stress value of the specific soil.

**Under consolidated Soils:** if the pre-consolidation stress value is less than to the initial vertical effective stress value of the specific soil.

Depending on the classification of the soil, the consolidation settlement can be found or predicted.

#### Distortion Settlement

Distortion settlement occurs when big loads are applied over a small area of the soils provoking the soil to deform laterally. This type of settlement is usually smaller than consolidation settlement.

#### Structure Loads in Soils

Structure loads are transferred to the ground producing compressive and shear stresses in the soil. Sometimes, the shear stress can be enough to cause a failure on the soil and furthermore the collapse of the structure.

## 2.2 Reconstruction vs. Repair of Dams.

The decision whether or not to remove a dam is based on a detailed analysis of the existing condition of the dam, and the positive and negative consequences of removal and reconstruction. There are some relevant independent variables affecting the decision taken, they are: safety condition, habitat/environmental impacts, historical value, owner, regulations and cost.

As mentioned previously, removal of a dam, partially or complete, is applied according to the actual characteristics of the dam structure and all these independent variables. During this process, there are some other aspects/data to take in consideration such as a stipulation of in stream structural enhancements to support fish passage and river habitat, watershed hydrology, changes in hydraulic conditions at bridge crossings, base and storm flows alterations, sediment loads, the influence of machinery involved in the removal and construction of the dam, and urban reactions to the situation.

## 2.3 Environmental Concerns.

A dam has many environmental impacts on the surrounding ecosystem. The dam changes the flow patterns of a brook or river, from highly oxygenated and low temperature to little dissolved oxygen and higher temperatures. This has impacts on the surrounding flora and fauna, where species that thrive in a location because of its temperature and/or oxygen values will experience a large decrease in population due to the change in habitat. For example,

species of mussels rely on spawning fish to transport their larvae upstream. With a barrier in place, more species than anadromous fish suffer from the inability to spawn in different environments.



Figure 73. Mussels downstream of the dam.

Dams also have environmental safety issues, the majority of which pertain to public safety and the ability of the dam to hold back flood waters.

## 2.4 Fish Ladder

In the past, ecological impacts were not taken into account when a dam was being designed or constructed. Migratory fish species were one major example of this ecological impact. For years, fish species had migrated through river systems to spawn and live according to temporal changes. Upon dam construction, these fish were unable to successfully migrate to needed locations for spawning. Subsequently, fish species populations have declined dramatically over the years.

To combat this problem, dam removal is not a feasible option for most areas, especially in the northeast. The reason this option is rarely feasible is due to the fact that many cities and towns have inhabited areas surrounding the water ways both upstream and downstream. In order to maintain a balance between social tolerance and the ability for fish species to travel throughout the river system, fish passages have been devised.

Fish passages have become prevalent in all areas of the world. As ecological importance becomes more and more of an issue in the area of civil engineering as a whole, fish passage incorporation is becoming an increased concern to dam construction and rehabilitation.

### 2.4.1 Types of Fish Passages.

Past dams were construction with different design criteria and constraints. It is because of this that fish passage design can go in many directions. Main goals in the design include, but are not limited to, to allow recognized fish species to pass effectively back and forth through the

system, to ensure feasible construction costs, and to maintain social tolerance. Different strategies have been created over the years to best fit these criteria. Although the following types of fish passages explain basic design, fish passage design can change considerably depending on the specific needs and constraints of the proposed site.

### *Pool and Weir*

A pool and weir design is the oldest of the fish passage designs. A pool weir design incorporates a series of small dams or “steps” by which fish have time to rest in pooled off areas before traversing the next barrier known as a weir.

### *Denil Fishway*

This type of fish passage contains symmetrical closely spaced baffles on the sidewall and floor. The fishway is usually sloped between 1:5 and 1:8. (Quinn 1990). The reason for these baffles is so that the velocity of the water flowing downstream decreases considerably by altering the direction of the flow. (Kamula, et al 2001). To decrease the velocity of the water, different flow directions are involved. The first flow direction is the apparent downstream flow. The baffles create other lateral flows. This process enables the velocity of the water to decrease. Figure 75 below shows the cut-out of a denil fishway.

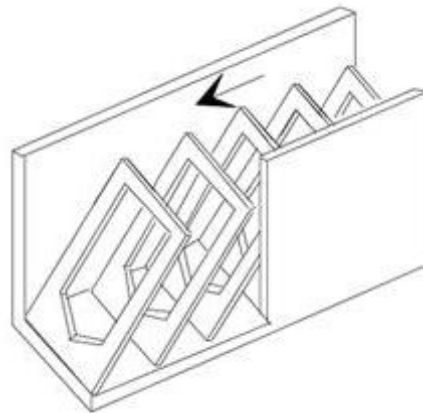

Figure 74. Denil Fishway

The following equation was formulated by studies at the University of Alberta, Canada since the 1984 that have been accepted for design features of a Denil fishway passage:

$$Q_* = \alpha \left( \frac{y_o}{b_o} \right)^\beta$$

Where  $\alpha$  and  $\beta$  are constants depending on the structure geometry of the fishway,  $Y_0$  is the water depth in the flume, and  $b_0$  is the width of the free opening, and in Equation 2

$$Q_* = \frac{Q}{\sqrt{gS_o b_o^5}}$$

where  $S_0$  is equal to the bottom slope of the fishway.

### Vertical Slot Fishway

Another common type of fish passage is the vertical slot fishway. This type of fishway consists of a number of pools of equal lengths. Vertical slot fishways can have a rectangular channel with a sloping floor or pool weir type “steps.” Narrow slots are evenly placed along one or both sides of the sidewalls for the water to pass, where the fish climb to each pooled off area. Vertical slot fishways are functional in the sense that the depth of the water at each pass varies so that the fish can pass upstream at the preferred depth. This type of fish passage may or may not have pool weir characteristics, where there are levels or “steps” to each pool.

Taken from Rajaratnam *et al.* (1992), the design equation for a vertical slot fishway is

$$Q^* = \alpha^* y_0 / b_0 \pm \gamma,$$

where  $\gamma = -1.11$  when  $(y_0/b_0) \leq 10$ , and  $\gamma = -1.62$  when  $(y_0/b_0) \geq 10$ .

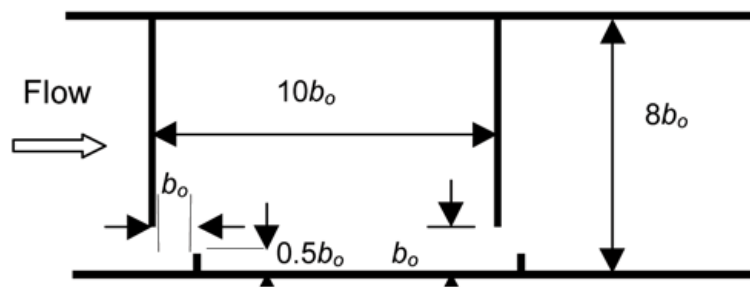

Figure 75: Plan View of Vertical Slot Fishway

Regardless on the type of passage chosen for the proposed site, the pool volume is sized in the same manner. The final pool volume is determined by taking the peak rate of fish passing through the passage (fish per minute) and multiplying that by the minutes allowed for the fish to stay in each pool. A common value for this is 3-5 minutes. This value is multiplied by the pool volume per fish. This calculation is based on the amount of fish that would run during the peak time of migration. The type of fish is also a concern. Common values are described below; each determined based each fish needing 0.5 FT<sup>3</sup> per pound that they weigh.

American Shad @ 4lbs.	2 FT <sup>3</sup> /fish
Atlantic Salmon @ 8lbs.	4 FT <sup>3</sup> /fish
River Herring @ 0.5 lbs.	0.25 FT <sup>3</sup> /fish

After this pool volume is determined, a factor of safety is added to allow for other species of fish and difference in seasonal water levels. This factor is usually between 10 and 15% more than the calculated pool volume.

## 2.5 Morey's Bridge Dam: Existing Conditions

Morey's Bridge Dam is located on the northern shore of Sabbatia Lake in the city of Taunton, Bristol County, in the state of Massachusetts. The dam is in the latitude of  $41^{\circ} 56' 02.684''$  N and in the longitude of  $71^{\circ} 06' 28.348''$  W on the Taunton USGS Quadrangle. The dam's spillway is located under Morey's Bridge. The main purpose of Morey's Bridge Dam is to control the quantity of water flowing from Lake Sabbatia to Mill River.

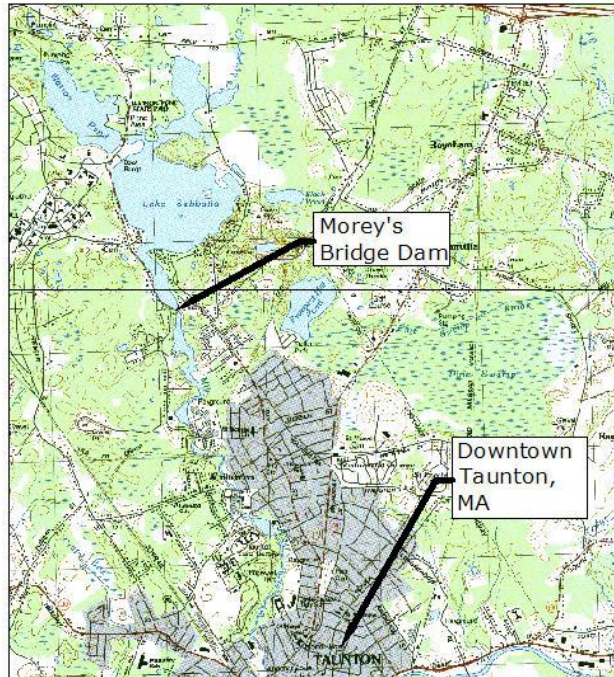

Figure 76. Mill River location.

The following figure shows the poor condition of the current spillway. This spillway is located directly under the gatehouse.



Figure 77. Spillway condition below the gatehouse.



## 2.5.1 DCR Size & Hazard Classification

Morey's Bridge Dam has been classified as a small sized structure, according to the Department of Conservation and Recreation Office of Dam Safety classification in the state of Massachusetts. Morey's Bridge Dam had been classified as high hazard zone. Oil from the spillway gates has spilled all over the river causing death to most of the living species, such as mussels, and algae.

## 2.6 Pertinent Engineering Data

### 2.6.1 Drainage Area

Information on the drainage area and flow rates was found using the USGS Stream Stats program which uses information from stream gauging stations and geographic data to calculate these values.

### 2.6.2 Reservoir

According to the city's conservation agent, the current level of the lake must stay high to maintain a water table depth that will charge some of the surrounding wells. The level that the lake is at in a dry season (late summer) may be used as the target water level for the dam design.



Figure 78. Downstream view of current spillway structure.

## 2.7 Constraints on Mill River Restoration Projects.

The main design constraint on this project is the placement of a temporary coffer dam between Lake Sabbatia and the Mill River. As a consequence of this temporary structure Mill River has been drying out causing death to the aquatic species and vegetation. The placement of the coffer dam is a significant spatial constraint on the project, because such a structure would be

necessary to construct the new dam and using the coffer dam in place would decrease the construction cost significantly. The figure below shows the space between the temporary coffer dam currently in place, and the gate house of Morey's bridge dam. It is favorable to place the new structure in between the coffer dam and the gatehouse.



Figure 79. Coffier Dam.

### **3 METHODOLOGY**

The goal is to build a new dam that can hold back flood waters, such as those observed during 2005 and 1996 in Taunton, while allowing the target species (alewife) to pass the barrier. It will take a series of well-planned steps to collect and analyze the information required to create a design that will satisfy the technical and aesthetic requirements of the site. The steps include assessing the current conditions, reviewing pertinent literature and reference materials to gain background information and technical references, designing the hydraulic and structural aspects of the dam and passage, and assessing the costs of different construction techniques.

#### **3.1 Define the Problem and Goals.**

The deteriorating dam presents a problem, with ecological and public safety implications. By creating a barrier to aquatic species that travel upstream/ downstream to spawn, the current dam structure disrupts the natural cycles of the species inhabiting this section of the Mill River. In its deteriorating state, the structure is also a threat to public safety because it may not be structurally capable of withholding flood waters in the near future. The community surrounding Lake Sabbatia would like to see the water elevations rise. An elevation in the water levels, however, may lead to water quality issues concerning septic system and well locations.

The goal is to find a solution that satisfies the ecological, structural, and social requirements of the site. Structural rehabilitation of the dam is necessary to be sure it can withstand the seasonal fluctuations in water level and river flows. Passage must be provided for the aquatic species to travel past the dam. Water level of Lake Sabbatia must be considered, to find elevations that are both environmentally safe, do not lead to septic-related pollution problems, and satisfy the community surrounding the lake.

#### **3.2 Assess and analyze existing site conditions**

One of the first topics to be explored for the project is the volume of water passing through the site. Expected flow rates and seasonal fluctuations are important to both the hydraulic and structural designs of the project. The values used in this analysis are estimates made by taking into account reliable resources of information and data collected. Hydraulic aspects such as present flows and drainage conditions must be analyzed to design a dam that is structurally able to withhold the force of seasonally varying flows, and a fish passage that will successfully pass alewife.

##### **3.2.1 Literature review**

Techniques involved in dam replacement were researched to find common ways that dams are removed and replaced. As the site already has a temporary cofferdam in place, the issue of holding back the waters of Lake Sabbatia while the dam is replaced will not be researched.

Possibilities for the design of the incorporation of passages into dams will be researched by both reading literature, reports, and meeting with a local expert on retrofitting dams with fish



ways. While the site under analysis will have a dam designed to incorporate the fish way (no retrofitting necessary) this is a way for the team to explore many placement and orientation options for the fish way, which will lead to flexibility in the design process.

As a dam drastically changes the landscape and ecosystem around it, the environmental impacts of dam replacement will be researched. The release of sediments trapped by the dam structure may become an environmental issue downstream after the dam is constructed.

### **3.2.2 Present dam assessment**

Optimally, the dam inspection reports for Morey's Bridge Dam will be accessible to the team to collect data about the existing conditions of the site. It is however likely that the inspection reports will not be accessible. In this case, the team will work from a base of assumptions, made by a site visit and investigation, and also from drawings obtained from the plans for the current coffer dam on the site. These drawings can provide the team with information such as site dimensions and elevation data. Any assumptions made will be clearly defined and explained throughout the analysis.

### **3.2.3 Identify design constraints**

Early identification of the constraints that the current site conditions place on the structural and hydraulic designs is important to the design process. This can help eliminate many options sooner rather than later, and allow the team to focus the analysis on viable options. Regulations for public safety and the construction of dams will be taken into consideration first, along with spatial and hydraulic constraints.

## **3.3 Hydraulic Design**

Both the spillway and fish way will be hydraulically analyzed as open channel flows. Back water curves, hydraulic profiles, velocities, turbulence, and flow volumes will be calculated and used to make recommendations for the structural requirements of the site. USGS has stream gauging sites placed throughout the United States. These sites monitor the flow in various streams daily, and the team will use this data to determine design flows for the spillway and fish passage. Incorporating this data, along with the analysis method recommended by Dick Quinn, and Probable Maximum Flood (PMF) and Probable Maximum Precipitation (PMP) using HMR-51, HMR-52, and HEC-1 from the USACE, flow volumes will be determined for the design of the passage, spillway, and dam elevation.

### **3.3.1 Dam & Spillway**

Hydraulic analysis of the spillway will start with the analysis of the PMP and PMF volumes. PMF and PMP volumes will also be used to determine the maximum design requirements for the dam by determining the maximum force of potential flood waters on the dam. Using guidelines set by the USACE, the spillway will be designed to accommodate approximately half of the PMF flow. The hydraulic characteristics of the spillway outflow will be analyzed to avoid high velocities and turbulence.

### **3.3.2 Fish Passage**

The target species, alewife, has characteristics that need to be accommodated through both the structural and hydraulic designs. One aspect of this design is the combination of the flows and depths that these fish need to swim through, and the structure that will allow these flows and depths to be achieved. Recommendations for the depth, velocity, and allowable waiting time for these fish will be taken from Dick Quinn and applied to the site. For example, alewife are primarily a swimming species, not a jumping species. Therefore, there must be adequate overflow from one section of the fish way to the next for these fish to swim and not have to jump over a weir.

The types of fluctuations in the flow during the migration season will determine what type of fish way is most appropriate for the site. After design flows are established, the fish way designs that seem most appropriate for the site will be analyzed in further detail.

After hydrologic analysis of the seasonal flows on the site, the structural and hydraulic designs of the passage will be closely intertwined. The structure of the passage defined the profile of the water flowing through it. Therefore, a series of trial and error calculations will most likely lead to the final design. Basic hydraulic design equations utilizing cross sectional area, flow volume, and structural characteristics will be used to design a passage that is passable for these fish.

## **3.4 Structural Design**

Structural design will focus on designing a dam that can safely control flood water and maintain favorable water elevations on Lake Sabbatia, and designing a passable fish way to maximize alewife passage during the migratory season.

### **3.4.1 Dam & Spillway Structure**

Using the information obtained in the dam inspection reports, or assumed in the absence of the inspection report, an appropriate technical design for a new dam structure will be determined. Viable options for the dam design will be identified, taking into account the constraints of the site. Structural design elements of the spillway may involve both the aspect of the design, and the hydraulic qualities of the spillway structure. Depending on the amount of energy that needs to be dissipated from the water flowing over the spillway structure, baffles may be incorporated into the design.

The USGS soils profiles of the area will be used in determining the foundation of the structure. The seasonal flow volumes will be analyzed to determine the structural requirements for the dam. The materials and form of the structure will be designed after the hydraulic forces have been analyzed also. The options determined to be most appropriate for the site will be analyzed in detail.

### **3.4.2 Fish Passage**

Structure of the fish passage will be determined using the hydraulic analysis of the USGS stream gauge data. The structure and orientation will be designed under the spatial constraints of the

site and using the recommendations of Dick Quinn. Some of these recommendations include keeping the passage within a certain distance of the spillway outlet. The fish way may incorporate designs from the pool and weir style, or the denil fishway. Specific dimensions of the passage will be specific to passing Alewife within the migration months.

### **3.5 Evaluate the Economic Factors.**

The economic feasibility of the design is just as important as its hydraulic and structural feasibility. Estimate for the costs involved in this design will be made using values found in the ENR Construction and Materials Cost Indexes. As these values may fluctuate during the design process, prices will be presented close to the end of the design period in an attempt to make the estimates as close as possible to reality. This cost breakdown will be visually presented in the final report.

### **3.6 Write Report**

A final report will be presented to both summarize and explain in detail the process used to create a design fulfilling the goals of the project. This report will include detailed analysis and design of the final dam, spillway and fish passage structures.

## Works Cited

- Walters, R.C.S. *Dam Geology*. London: Butterworth's. 1962
- Commonwealth of Massachusetts Riverways Program.  
<http://www.mass.gov/dfwele/river/programs/priorityprojects/millriver.htm> (accessed September 8, 2007).
- Delaware River Foundation. "Let it Flow -Newsletter of the Delaware River Foundation." Vol.4 Issue 2. <http://delawareriverfoundation.org/Nov%202004%20Newsletter.pdf>. (accessed September 13, 2007)
- Golzè, Alfred R., Ed. *Handbook of Dam Engineering*. New York: Litton Educational Publishing, 1977.
- Herzog, Max A.M. *Practical Dam Analysis*. London: Thomas Telford Publishers, 1999.
- Houghtalen, Robert J., and Ned Hwang. *Fundamentals of Hydraulic Engineering Systems*. Upper Saddle River: Prentice Hall, 1996.
- John Muir Institute of the Environment. "Natural Fish Passage Structures in Urban Streams (Part 2: Hydrologic design and analysis).  
<http://repositories.cdlib.org/cgi/viewcontent.cgi?article=1007&context=jmie/roadeco> (accessed September 10, 2007).
- Massachusetts Department of Fish & Wildlife. "Lake Sabbatia."  
<http://www.mass.gov/dfwele/dfw/habitat/maps/ponds/pdf/dfwsabbi.pdf>. (accessed September 13, 2007).
- Nyman, David C. "Restoration for an Urban River: Some Lessons Learned." ENSR International.  
<http://www.ucowr.siu.edu/proceedings/2005%20Proceedings/Conference%20Proceedings/07-12-05%20Tuesday%20PM2/Session%2010/10.3.Nyman.pdf> (accessed September 10, 2007).
- River and Stream Continuity Project. "Massachusetts River and Stream Crossing Standards."  
<http://www.nae.usace.army.mil/reg/MAStreamCrossingGuidelines.pdf> (accessed September 10, 2007).
- Transportation Association of Canada. *Guide to Bridge Hydraulics*. London: Thomas Telford Publishing, 2004.
- U.S. Department of Agriculture Soil Conservation Service, Massachusetts Agricultural Experiment Station. *Soil Survey of Bristol County, Massachusetts, Northern Part*. 1978.
- U.S. Department of the Interior Bureau of Reclamation. *Design of Small Dams*. Second ed. 1977.

## Appendix A. Mill River Location & Soil Data



Figure 80. Morey's Bridge Dam.

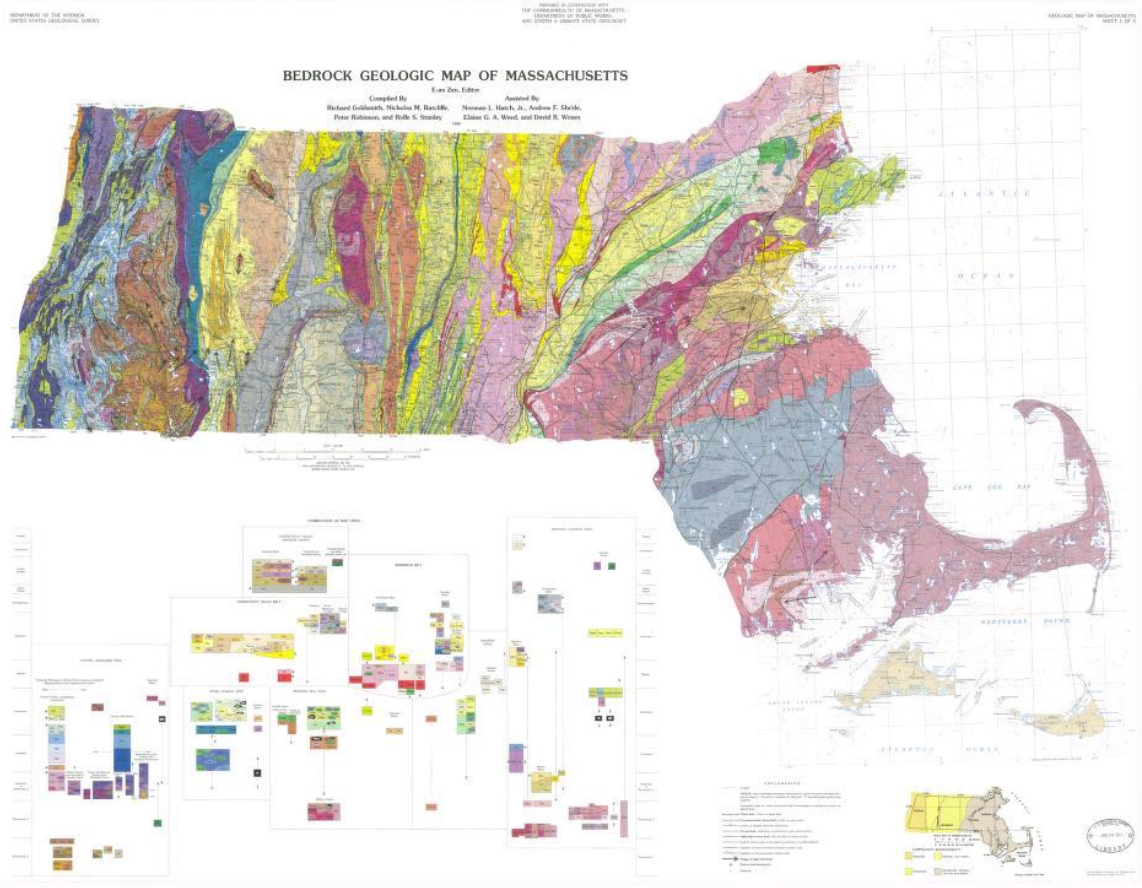

Figure 81. Bedrock Geology Map A. (USDA Soil Conservation Service 1978)

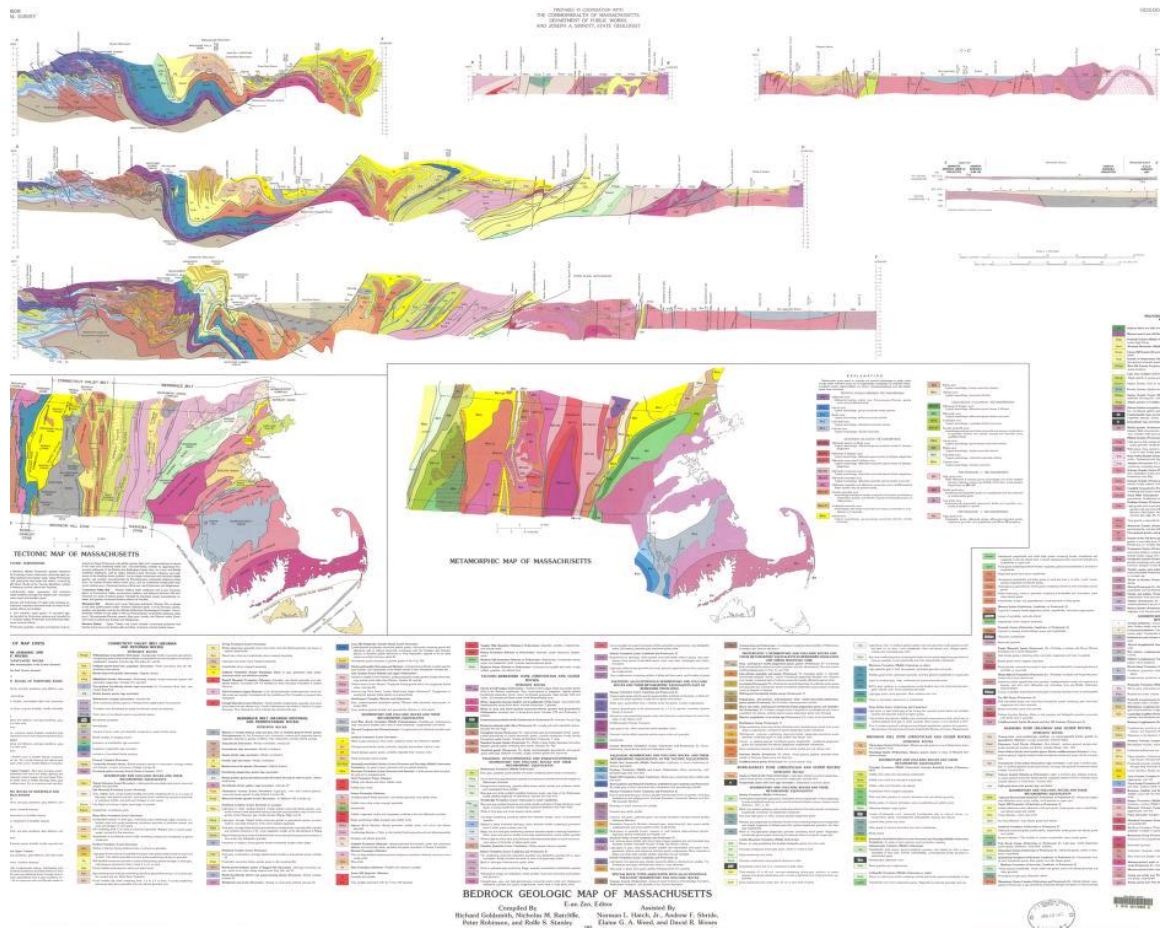

Figure 82. Bedrock Geology Map B. (USDA Soil Conservation Service 1978)