

STRUCTURE-PROPERTY RELATIONSHIPS IN ANGIOPLASTY BALLOONS

by

Samantha Garramone

A Thesis

Submitted to the Faculty

of the

WORCESTER POLYTECHNIC INSTITUTE

in partial fulfillment of the requirements for the

Degree of Master of Science

in

Materials Science and Engineering

by

May 2001

APPROVED:

Satya S. Shivkumar, Advisor

Richard D. Sisson, Jr., Materials Science and Engineering Program Head

Abstract

Balloon angioplasty, used to clear clogged blood vessels, is the most common medical intervention in the world. In an effort to improve on an angioplasty balloon currently on the market, extruded tubes were designed that were comprised of different numbers of layers of an 80/20 ratio of polyethylene terephthalate (PET) to a thermoplastic elastomer. Balloons were fabricated from these tubes, and tested for burst strength, puncture resistance, and compliance. Lastly, these properties were correlated to the material configuration of the balloons. It was found that, although the burst strength and compliance of the balloons was not significantly effected, increasing the number of layers while keeping the ratio of materials constant lead to a linear increase in the puncture resistance and toughness of the balloons. This is important because it shows that one of the angioplasty balloons currently sold can be improved simply by changing the configuration of the materials, instead of having to research new medical grade polymers and how to process them.

Acknowledgements

I would like to thank Dr. Ron Sahatjian, head of Corporate Technology at the Boston Scientific Corporation, and Prof. Satya Shivkumar, my advisor, for allowing me to complete this thesis using their joint resources. I would also like to thank Dave Vafiades and everyone else at Boston Scientific who helped me along the way, especially the Extrusion Department for making all of the tubes that I needed to fabricate my angioplasty balloons.

Table of Contents

1.0 Introduction	1
2.0 Background	2
2.1 The Angioplasty Procedure	2
2.2 Ideal Balloon Properties	3
2.2.1 Mechanisms of Balloon Angioplasty	4
2.3 Balloon Materials	7
2.3.1 Compliance	7
2.3.2 Current Materials Used	9
2.4 Mechanics of Balloon Fabrication	11
2.4.1 Tube Design	12
2.4.2 Tube Crystallization	13
2.4.3 Free-Blowing of Balloon	15
2.4.4 Balloon Heat-setting	16
2.5 Mechanisms of Failure in Polymers	18
2.5.1 Stress Models and Yielding Behavior	19
2.5.2 Effect of Polymer Crystallinity on Fracture Resistance	22
2.5.3 Effect of Polymer Orientation on Fracture Resistance	23
2.5.4 Effect of Polymer Thickness on Fracture Resistance	24
2.5.5 Effect of Layering on Fracture Resistance	24
2.6 Objectives	30
3.0 Materials and Methods	30
3.1 Materials	30
3.2 Tube Configurations	31
3.3 Balloon Fabrication	32
3.3.1 Tube Crystallization	33
3.3.2 Free-Blowing of the Balloon	33
3.3.3 Heat-Setting of the Balloon	34
3.4 Balloon Verification	34
3.5 Testing of Balloon Properties	36
3.5.1 Puncture Test	36
3.5.2 Compliance Test	37
4.0 Results and Discussion	37
4.1 Ideal Stretch Ratio Determination for Twelve-layer Balloons	38
4.1.1 Additional Stretch Ratio Manipulation	41
4.1.2 Failure of Tubes with New Stretch Ratios	43
4.1.3 Selection of the Ideal Stretch Ratio for Multilayer Balloons	45
4.2 Twenty-layer Balloons	45
4.2.1 Effect of Extrusion Parameters on Balloon Characteristics	46
4.2.2 Effect of Tube Orientation on Balloon Properties	47
4.3 Effect of Multilayer Structure on Balloon Properties	49
4.3.1 Burst Strength	49
4.3.2 Puncture Resistance	52
4.3.3 Compliance	56
5.0 Conclusions and Recommendations	56
6.0 References	59

1.0 Introduction

Material and processing considerations are very important in the fabrication of an angioplasty balloon. During its use in the human body, the balloon is subjected to many harsh conditions that could cause it to fail. The prevention of this failure is especially important because a human life is involved.

There are many angioplasty balloon catheter systems on the market today that are all required to perform the same basic tasks, whether in the coronary or peripheral areas of the body. The balloon must open the vessel lumen in such a way that it stays open and no harmful debris is created, while not injuring the vessel wall structure.

These tasks can be achieved through the careful selection of the materials that comprise the angioplasty balloon and the process used to fabricate the balloon. Boston Scientific Corporation, a world leader in the angioplasty market, currently manufactures balloons that contain a polyethylene terephthalate (PET) core layer with an outer layer of a polyester-based thermoplastic elastomer. While these materials have proved sufficient for the achievement of some necessary properties of the balloon, it is possible that the two-layer structure is not maximizing their full potential.

This investigation was concerned with determining if angioplasty balloons comprised of the same ratio of PET to a polyester-based thermoplastic elastomer have different properties if the initial tube used to fabricate the balloon is extruded in several different multilayer configurations. This was done by designing different tube configurations, then fabricating the balloons and testing them for various key properties.

2.0 Background

2.1 The Angioplasty Procedure

At one time, if a person had coronary artery disease, a blockage of one or more of the arteries that feed the heart, the only option was bypass surgery, an expensive major operation requiring weeks or months of recuperation. That changed when, in 1977, Dr. Andreas Gruentzig performed the first percutaneous transluminal coronary angioplasty (PTCA) on a human. (He had also performed the first peripheral angioplasty in 1974.) Since 1980, when the first 1000 angioplasties were performed worldwide, the popularity of PTCA has grown exponentially. In 1997, over 1 million angioplasties were performed, making it the most common medical intervention in the world. That number continues to increase.¹

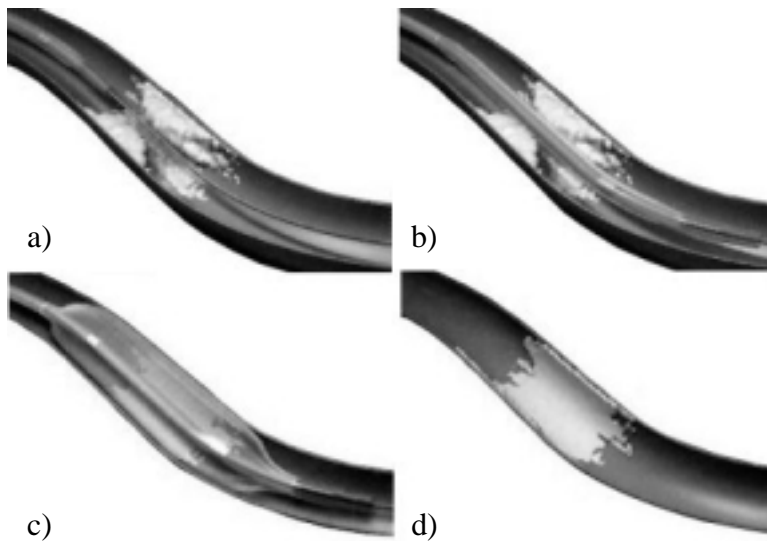

Figure 2.1 An angioplasty procedure being performed; a) illustrates a guidewire traversing a blockage in a blood vessel, in b) the angioplasty balloon can then be passed through the blockage and c) inflated, with the final result that d) the balloon is deflated and withdrawn, leaving a widened vessel lumen.²

Unlike bypass surgery, angioplasty is comparatively inexpensive, and requires only a few days of recuperation. During the procedure, a balloon-tipped catheter is inserted into a leg vein, and then threaded up to the site of blockage in an artery. First, a guidewire is passed through the blockage, making a path for the balloon. The balloon can then be inserted through the blockage and inflated, compressing the plaque and enlarging the inner diameter of the blood vessel so blood can flow more easily. The balloon is then deflated and the catheter removed (Fig. 2.1). Additionally, after the blockage is cleared, a balloon can be used to place a small, metallic stent (Fig. 2.2) into the artery to help keep the vessel open.

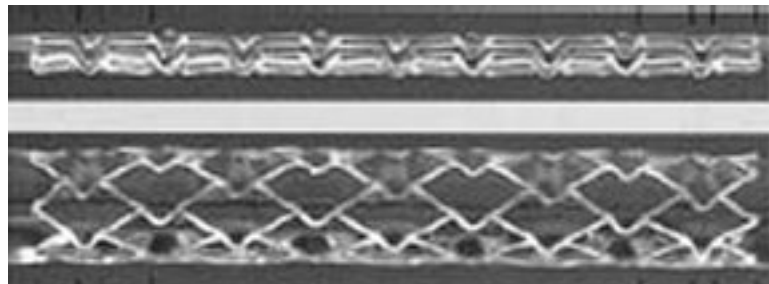

Figure 2.2 A NIR[®] stent before (top) and after (bottom) expansion.³

2.2 Ideal Balloon Properties

The ideal angioplasty balloon must have many, often conflicting, properties in order to achieve the goals of the procedure in the least invasive and most effective way possible. Foremost, a smooth outer shape and surface of the balloon is necessary so as not to harm the vessel wall while inside of it. In addition, the balloon must be durable and strong so that the environment that it is subjected to does not harm it. If the balloon does fail under excessive pressure or applied force, it will tear, and it is necessary that it

do so in a longitudinal manner because radial failure could lead to a piece of the balloon becoming detached from the catheter altogether and lodging in the blood stream (Fig. 2.3).⁴ All of these properties can be controlled through materials selection and processing and are related to the mechanisms of balloon angioplasty.

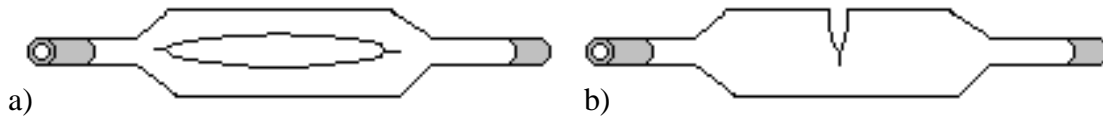

Figure 2.3 Illustration of a) longitudinal versus b) radial failure of an angioplasty balloon.

2.2.1 Mechanisms of Balloon Angioplasty

Since the introduction of the procedure, there have been many potential mechanisms put forth to explain the effectiveness of balloon angioplasty in opening vessels clogged with atherosclerotic plaque. After the balloon is inserted through the plaque, it is inflated, applying stress to the vessel wall, and the plaque inside of it as it expands (Fig. 2.4). The affect that this stress has on ameliorating the clinical symptoms of the patient with the clogged vessel has not always been fully understood.

Traditionally, it was thought that this stress actually caused the plaque to compress, as snow is compressed in a footprint. This implies that the volume of the atheroma is reduced, thus widening the lumen available for blood flow.⁵ This mechanism was subsequently disproved through clinical observations in favor of another mechanism involving the redistributive remodeling of the plaque.

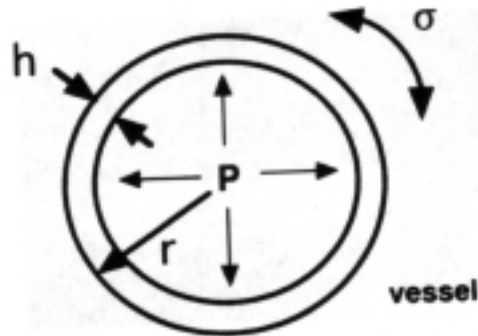

Figure 2.4 Mechanics of balloon inflation in an atherosclerotic blood vessel. As pressure (P) is applied inside the vessel, stress (σ) is produced in the vessel wall in relation to the thickness of the plaque (h) and the vessel radius (r) such that $\sigma = (Pr/h)$.⁶

Because Poiseuille's law states that resistance is directly proportional to the length of the stenosis, but inversely proportional to the fourth power of the radius, it is unnecessary to reduce the volume of the plaque to alleviate the patient's symptoms.* It is possible that simply redistributing volume from the center of the plaque to the length of the lesion is sufficient to reduce the hemodynamic resistance of a stenosis and increase blood flow. This redistribution has been observed in many patients.⁷

Another mechanism of vessel dilation has also been observed. Not only is the plaque redistributed, but the vessel wall is also deformed. When the balloon is inflated within the stenosis, two different things can occur as the plaque is pressed outward; either the plaque will be pushed against the vessel wall, or the plaque will fracture, allowing the

* Poiseuille's law describes the resistance to flow through a pipe as $R = (8\mu L/\pi r^4)$, where μ is the coefficient of viscosity (a constant for any given fluid), L is the length of the pipe, and r is the radius of the pipe. This is derived from simple fluid mechanics.

balloon to continue expanding (Fig. 2.5). In either case, there is a permanent increase in the overall vessel diameter, allowing blood flow to be restored.⁸

The exact mechanism of vessel dilation is dependent on the nature of the stenosis and the type of angioplasty balloon used. Typical balloon sizes produced range from 2mm wide and 2cm long to 10mm wide and 10cm long. The diameter of the balloon during use will vary depending on the materials that it is made out of.

Plaque has been observed in a range of characteristics, from hard and brittle, to soft and ductile, depending on the patient. In addition, balloons are manufactured with a range of different characteristics, each suited to a different type of stenosis. It is the surgeon's decision as to what mechanism of dilation he wishes to promote by observing the plaque and selecting a balloon catheter to use in the angioplasty.⁹

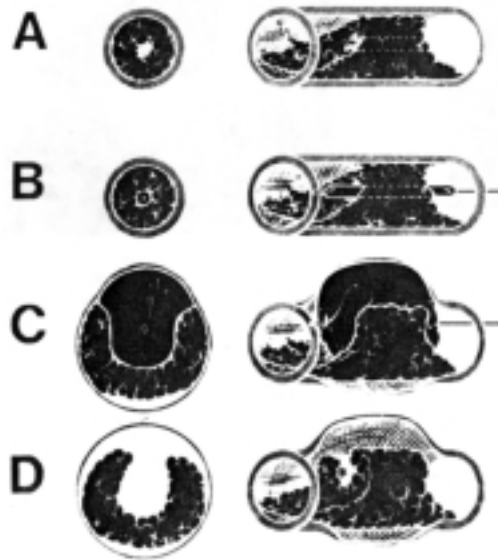

Figure 2.5 Opening of the vessel lumen through balloon angioplasty. (A) Cross-section and side-view of an artery clogged with plaque. (B) A balloon has been placed through the narrowed lumen of the vessel. (C) Upon inflation of the balloon, the plaque ruptures and the vessel wall expands. (D) Deformed vessel after removal of the balloon.¹⁰

2.3 Balloon Materials

The materials that an angioplasty balloon is fabricated from have a great affect on the final properties of the balloon. The first angioplasty balloons were fabricated out of polyvinyl chloride (PVC). These balloons were thick walled, and designed for low pressures. In the mid-1980's PVC was replaced with crosslinked polyethylene (PE), and polyethylene terephthalate (PET), both able to withstand higher pressures. The newest materials to be introduced into the angioplasty balloon market were polyurethanes (PU) and nylons. A comparison of the properties of these materials can be seen in Table 2.1.

Table 2.1 Comparison of materials used to fabricate angioplasty balloons for PTCA. Compliance is the percent change in diameter over a given range of inflation pressures, and max. rated pressure is the maximum pressure the balloon can be inflated to before there is a danger of it bursting.¹¹

Material	Tensile Strength (psi)	Compliance (%)	Max. Rated Pressure (atm)
PET	>40,000	<5	20
Nylon	20,000-40,000	5-10	16
PE	<10,000	>10	10
PU	10,000-20,000	5-10	10
PVC	<10,000	>10	6-8

2.3.1 Compliance

Balloons are generally classified according to their compliance, or the percentage that their diameter expands over a given range of inflation pressures, which correlates to the materials that they were made of. Noncompliant balloons, such as those composed of

PET, expand less than 5% over their original radius. Semi-compliant balloons, such as those comprised of certain polyurethanes, expand from approximately 5 to 10%, and compliant balloons, such as those composed of PVC, can expand more than 10% over their original diameter during use.

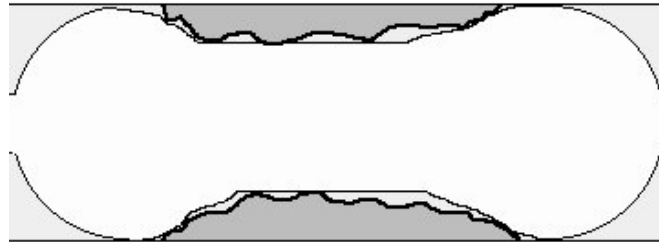

Figure 2.6 A compliant angioplasty balloon in a sclerotic blood vessel exhibiting “dog-boning”, or overexpanding in the regions beyond the plaque.

There has been some controversy as to which class of materials is the best for angioplasty balloons. Advantages to using compliant balloons include greater flexibility for appropriate sizing and the additional expansion that is available if an insufficient result is obtained at nominal pressure. Noncompliant balloons will not “dog-bone”, or overexpand in the regions beyond the stenosis, possibly injuring the vessel (Fig. 2.6). In fact, they can be carefully sized so as not to exceed the diameter of the vessel at all, thus not deforming it. Noncompliant balloons also tend to have a higher burst pressure for a given profile, making them better able to crack hard plaque without rupturing.¹² Many clinical studies have been conducted in order to determine if there is a higher rate of arterial dissection when one class of balloons is used versus the other, but no difference has been found.^{13 14 15} Surgeons must use their best judgment when deciding what type of balloon to use when performing an angioplasty, taking into account the type of lesion, and which level of compliance they are most comfortable with.

2.3.2 Current Materials Used

As discussed earlier, no one set of properties is desirable for all angioplasty balloon applications. Currently, most balloons are fabricated from either PET or nylon. While PET offers the advantages of higher tensile strength and ability to withstand pressure, nylon is softer and more easily refolded to be withdrawn from the body. PET does have one major advantage over all other balloon materials available today; the ability to maintain a low profile while being inflated to high pressures without bursting. While there are sufficient balloons currently available, continuing efforts are being made in the angioplasty balloon industry to explore new materials and different blends of materials to accommodate the growing market. New advances in angioplasty techniques, such as the use of stents, and even small metal blades to actually cut into plaque, require balloons to be more puncture resistant than ever before to ensure the safety of the patient. In addition, companies are always striving to achieve the lowest balloon profile possible to make the procedure the least invasive possible. Higher burst strengths allow for the balloon walls to be thinned and still receive the same pressure ratings as thicker balloons.

A novel balloon that Boston Scientific has on the market today has two layers of materials, each of these layers being a blend of two other materials (Fig. 2.7). The inner layer is the thicker, load-bearing layer and it is PET based. The outer layer is much thinner, but adds durability. It is comprised of a polyester-based thermoplastic elastomer called Hytrel[®]. A balloon consisting solely of PET would have a higher burst strength than one consisting solely of Hytrel[®], and a Hytrel[®] balloon would have a higher puncture resistance than a PET balloon, but it would have a much lower burst strength.

The use of PET and Hytrel[®] as separate layers in one balloon allows the desirable properties of both materials to be maintained, while canceling out their weaknesses.

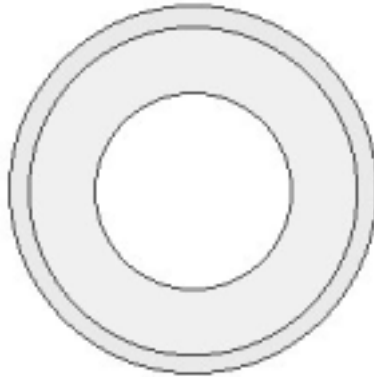

Figure 2.7 Cross-section of an extruded tube used to fabricate a two-layered angioplasty balloon. The inner layer is PET, and the outer layer is Hytrel[®].

This combination of strength and durability from the PET and Hytrel[®] is advantageous, but problems necessitated the addition of other materials into the two-layered balloon. PET tends to stick to itself when exposed to compression, moisture, or heat (which it undoubtedly would be when folded onto a catheter and sterilized) so a small amount of a toughened homopolymer polyester was added to the PET layer to alleviate this problem. In addition, the grade of Hytrel[®] with the desired properties would not adhere to the PET, so it was blended with a small amount of another grade with less desirable properties, but better adhesion.¹⁶

2.4 Mechanics of Balloon Fabrication

Angioplasty balloons, such as those described above, are fabricated by first designing a tube that is extruded in certain dimensions. This tube is then crystallized so that only a small length is left amorphous, and then the tube is free-blown into a balloon in a machine designed for that purpose. Lastly, the balloon is heat-set. All of these processes are carefully controlled in order to achieve a balloon that meets the necessary standards. An illustrated flowchart of the entire balloon fabrication process can be seen in Fig. 2.8.

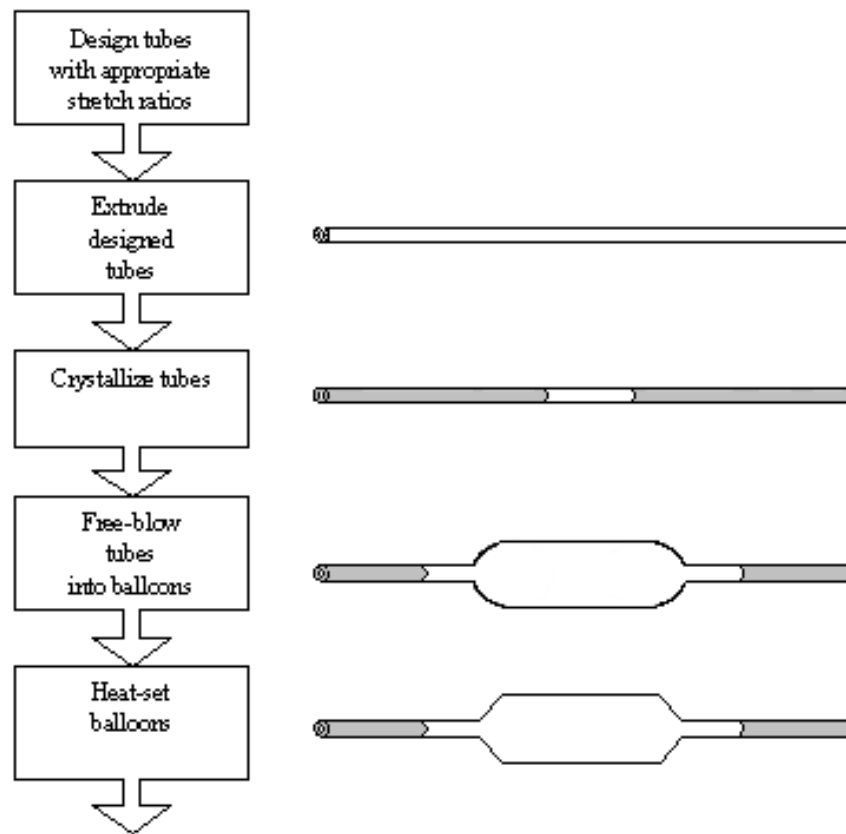

Figure 2.8 Illustrated flowchart of the processes involved in the fabrication and testing of balloons.

2.4.1 Tube Design

The design of the extruded tube is important because it dictates the final dimensions of the angioplasty balloon and its failure mode. Stretch ratio calculations are employed in order to predict these characteristics. Different size balloons are necessary for different applications, and all of these balloons have a required length (L), double wall thickness (Tc), and inner (ID) and outer (OD) diameter. These are the basic parameters used for the stretch ratio calculation. The two calculations involved in the determination of the stretch ratio are the circumferential growth (CIRG) and the longitudinal volume distribution factor (LVDF). They are calculated in the following manner (with V = volume, and A = cross sectional area):

$$LVDF = \frac{(V/L)_{tube}}{(V/L)_{balloon}} = \frac{A_{tube}}{A_{balloon}} = \frac{\left(\left(\frac{OD}{2}\right)^2_{tube} - \left(\frac{ID}{2}\right)^2_{tube}\right)}{\left(\left(\frac{OD}{2}\right)^2_{balloon} - \left(\frac{ID}{2}\right)^2_{balloon}\right)} \quad (1)$$

$$CIRG = \frac{(OD/2)_{balloon}}{(ID/2)_{tube}} \quad (2)$$

The stretch ratio is expressed as (CIRG/Q) where Q is the ratio of CIRG to LVDF.¹⁷ The ideal stretch ratio for a standard 5mm wide by 4cm long balloon has been accepted as approximately 8/2. Additionally, it has been found that a Q value of no more than 2.4 corresponds to a favorable mode of balloon failure.¹⁸ The tube ID and OD that will lead to the desired stretch ratio are determined by entering possible choices into a spreadsheet that calculates the stretch ratio, along with the desired OD and Tc of the final

balloon (in order to calculate the balloon ID). Once the correct tube ID and OD are found, the tubes can be extruded to those dimensions.

2.4.2 Tube Crystallization

After extrusion, tubes with a specific inner and outer diameter are obtained. For a 5mm balloon, the tube wall is approximately 0.020” thick. The tubes are then crystallized except for a small segment in the center. Placing the tubes on a heated block with a gap in the center allows them to crystallize except for the section above the gap. This amorphous section is the only part of the tube that will expand during the free-blowing procedure. Its length can be manipulated in order to influence the dimensions of the balloon. For PET, the temperature of the heating block and the amount of time used are related to the known melting and glass transition temperature of the material as determined by Golike and Cobbs, in Eq. 3.¹⁹

$$\log \frac{1}{t_{1/2}} = b_0 - \frac{b_1}{T - T_g} - b_2 \left[\left(\frac{1}{T} \right) \left(\frac{T_m}{T_m - T} \right)^2 \right] \quad (3)$$

Where the variables are defined as follows:

$t_{1/2}$ = the total time between the start of heating and the halfway point of crystallization

T = the temperature the polymer is being heated at

T_g = the glass transition temperature of the polymer (~70°C for PET)

T_m = the melting temperature of the polymer (~265 °C for PET)

$b_0 = 1.97$ $b_1 = 137$ $b_2 = 1.03$ (constants derived for PET)

Using this equation, a plot of the half time crystallization rate versus temperature for PET can be made so as to determine a sufficient amount of time to heat the polymer at a chosen temperature to achieve maximum crystallinity (Fig. 2.9).

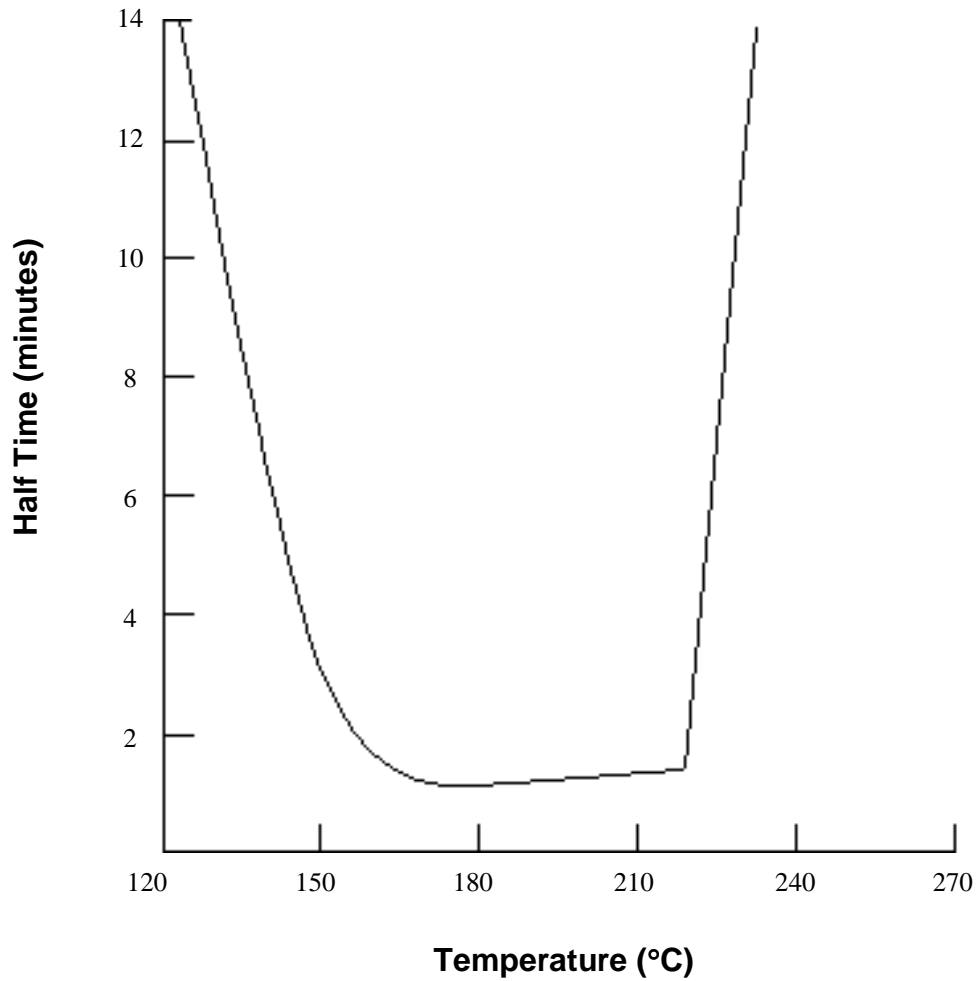

Figure 2.9 Half time crystallization rate versus temperature for PET.²⁰

2.4.3 Free-Blowing of Balloon

Following crystallization, the extruded tubes are ready to be free-blown into balloons. There are specially designed machines (henceforth referred to as “balloon machines”) in order to do this (Fig. 2.10). The extruded tube is threaded between two movable grippers and one end is sealed off. The other end is connected to pressurized nitrogen. The tube is then submerged in a bath of glycerin, inflated, and drawn. All of these steps influence the final size and shape of the balloon.

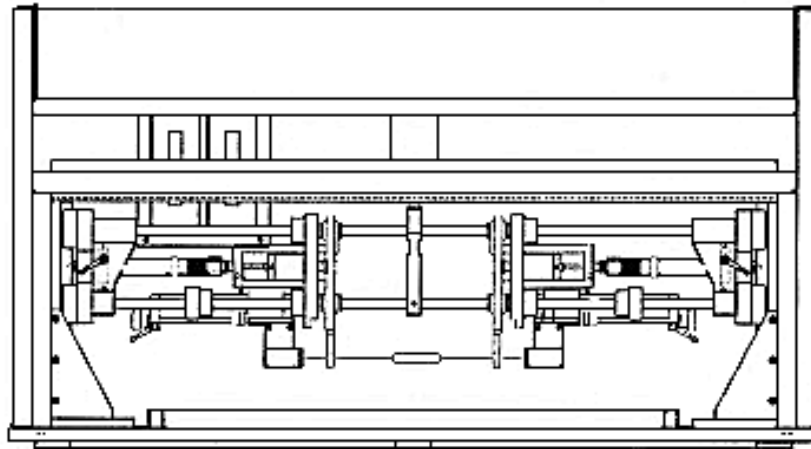

Figure 2.10 A typical machine used to free-blow angioplasty balloons. The balloon has been blown from a tube threaded between two grippers that was lowered into a glycerin bath and pressurized.²¹

Foremost, the temperature of the bath and the length of time that the tube is subjected to it are important. Glycerin is used because it has beneficial heat transfer properties at the temperatures required. Heat is transferred through the wall of the extruded tube through convection and conduction. The tube will not inflate until the surface of the inner diameter (ID) has reached the glass transition temperature of the

material. The ID is the coolest part of the tube, and also the part that orients the most when blown.

Inflation of the balloon is related to its longitudinal and hoop stress. Because the hoop stress is twice the longitudinal stress, the inflation pressure and length of inflation time will tend to control the diameter of the balloon more than its length. When force is applied to the tube wall, the molecules begin to stretch. Because some chains of molecules are shorter than others, they reach their maximum length sooner. The molecules are also intermingled, and the interference between them will lead to a resistance in stretching in the direction of the applied forces. The stretch of the material is limited when molecular motion stops because the resistance overcomes the force. At this time, the tube will have expanded into a balloon with thin, oriented walls. For a 5mm balloon, these walls are approximately 0.001” thick. The greatest amount of orientation is in the hoop direction, with about half as much orientation in the longitudinal direction.

The addition of a pullout force during drawing can increase longitudinal orientation. Because this leads to less radial orientation, a balloon with a slightly smaller diameter is produced. Drawing is also used to form the tapered sleeves necessary for the ideal balloon shape.²²

2.4.4 Balloon Heat-setting

After a repeatable free-blow process is determined, and balloons of the correct size and shape are fabricated, the balloons must be subjected to a final, heat -setting procedure. This procedure is necessary to anneal the balloon and to relax it so as to

alleviate any shrinking that may occur during sterilization. In order to do this, the balloon must be exposed to a temperature higher than the sterilization temperature, but lower than its melting temperature because of the ability of many polymers to remember their heat history. For PET, the ideal temperature is the end of the crystallization peak of the material (Fig. 2.11). This is well between the two temperatures delineated above.

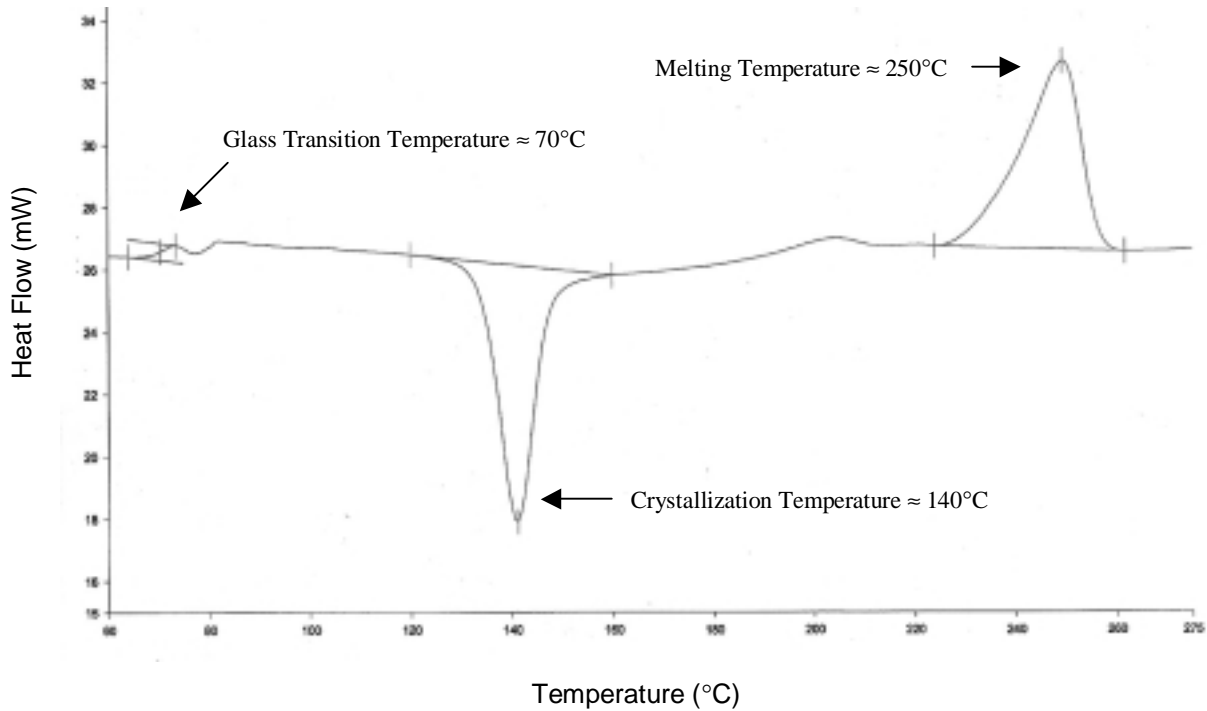

Figure 2.11 A Differential Scanning Calorimeter plot of an 80/20 PET/Hytrel[®] extruded tube used in this investigation, with the PET transitions labeled. The tube was heated from 0 to 300 °C at 20 °C/min in a Perkin-Elmer DSC7.

At this temperature, the balloon is crystallized as efficiently as possible so that it is the most stable and has the highest modulus.²³ In practice, PET cannot be 100% crystalline. The percent crystallinity is calculated by applying values determined by a DSC to the following equation:²⁴

$$\% Crystallinity = \left(\frac{\Delta H_m - \Delta H_c}{\Delta H_m^o} \right) \times 100 \quad (4)$$

With the variables defined as follows:

ΔH_m = the heat of melting (J/g)

ΔH_c = the heat of cold crystallization (J/g)

ΔH_m^o = reference value of the heat of melting if the material were 100% crystalline

(140 J/g for PET)²⁵

The increase in crystallinity of a PET angioplasty balloon is evident if the material is run through a DSC at each step in the process and the percent crystallinity is calculated. It can be seen that there is a marked difference in crystallinity from the beginning to the end of the process (Table 2.2).

Table 2.2 Percent crystallinity during each step of the PET balloon fabrication process, as calculated by Eq. 4. Each percent is the average from values taken from three DSC runs.

Processing Step	Percent Crystallinity
Extruded tube	~1%
Free-blown balloon	~30%
Heat-set balloon	~36%

2.5 Mechanisms of Failure in Polymers

After angioplasty balloons are fabricated, they are put through a series of tests to evaluate their various possible modes of failure. Any time that a balloon fails it is due to

the polymer fracturing, either as a result of a puncture, or stress from the pressure of the fluid filling the balloon. In the past, much research has been done to determine the mechanisms behind the fracture of polymers and the influence of different material properties on their toughness (or fracture resistance).

2.5.1 Stress Models and Yielding Behavior

For the purpose of stress analysis, an angioplasty balloon can be approximated as a cylindrical thin-walled pressure vessel because the thickness of its wall is less than one tenth of its diameter. Figure 2.12 illustrates the stresses acting on such a vessel. Only normal stresses are present because the conditions of symmetry exclude the existence of any shearing stresses in the planes of the sections, as shearing stresses would cause an incompatible distortion of the vessel.

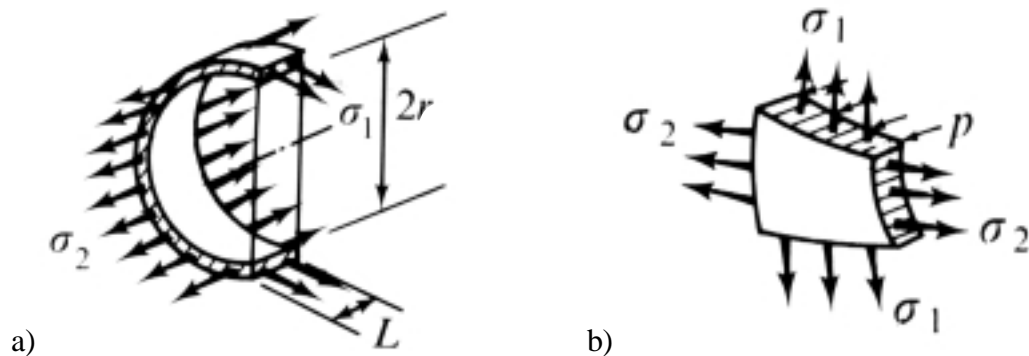

Figure 2.12 Applied stresses on a cylindrical thin-walled pressure vessel, where a) is a segment isolated from the vessel and b) is an element of the vessel wall in a state of biaxial stress. The normal stresses are σ_1 and σ_2 , p is the internal pressure of the vessel, r is the inside radius of the vessel, and L is the length of a longitudinal section of the vessel.²⁶

An equation for the circumferential, or hoop, stress can be derived by summing the forces in the radial direction and setting them equal to 0, as seen in Equation 5.

$$\sigma_1 = \frac{pr}{t} \quad (5)$$

In addition, the equation for the longitudinal stress is found by equating the force developed by the internal pressure and the force developed by the longitudinal stress in the walls, resulting in Equation 6.

$$\sigma_2 = \frac{pr}{2t} \quad (6)$$

In both Equation 5 and 6, p is the internal pressure of the vessel (created by a contained gas or fluid), r is the inner radius of the vessel, and t is the thickness of the wall. The hoop and longitudinal stresses are assumed to be constant throughout the wall of the vessel.²⁷

These stresses can be compared to calculated yield stresses in order to predict if the vessel will yield under given pressures at given thicknesses. Yield criterion developed by both von Mises and Tresca both propose to calculate these stresses using different methods. While the Tresca criterion predicts more conservative values, the von Mises criterion has been shown to be more accurate for states of biaxial stress, such as those experienced by an angioplasty balloon.²⁸ Because of this, the von Mises criterion was used for this investigation.

The von Mises yield criterion is based upon the Maximum Energy Failure Theory, which states that failure is caused by the component of strain energy that results in a change in shape, rather than the component that causes a change in volume. This theory is based on the observation that materials can be loaded with extremely high

hydrostatic pressure, even exceeding their apparent strength, without failure.²⁹ The equation for the von Mises yield criterion is as follows:

$$Y = \frac{1}{\sqrt{2}} \left[(\sigma_1 - \sigma_2)^2 + (\sigma_2 - \sigma_3)^2 + (\sigma_3 - \sigma_1)^2 \right]^{1/2} \quad (7)$$

Where Y is the tensile yield strength, and σ_1 , σ_2 , and σ_3 are the principle stresses. For a cylindrical thin-walled pressure vessel, such as an angioplasty balloon, combining Equation 7 with Equations 5 and 6, and knowing that $\sigma_3 = 0$, gives the following simplified equation (with all variables previously defined):

$$Y = \frac{\sqrt{3}}{2} \sigma_1 \quad \text{or} \quad Y = \left(\frac{\sqrt{3}}{2} \right) \left(\frac{pr}{t} \right) \quad (8)$$

In a polymeric material, yielding occurs when, under an applied stress, the chemical bonds within the polymer are stressed. As the stress increases, the bonds begin to break and small microcracks form, which coalesce into larger cracks. After these cracks are initiated, they propagate to failure. The way that these cracks form is related to the mechanisms by which the polymer must dissipate the energy of the applied stress, which is a function of the geometry, mode of loading, and material properties of the polymer, such as crystallinity and orientation.³⁰

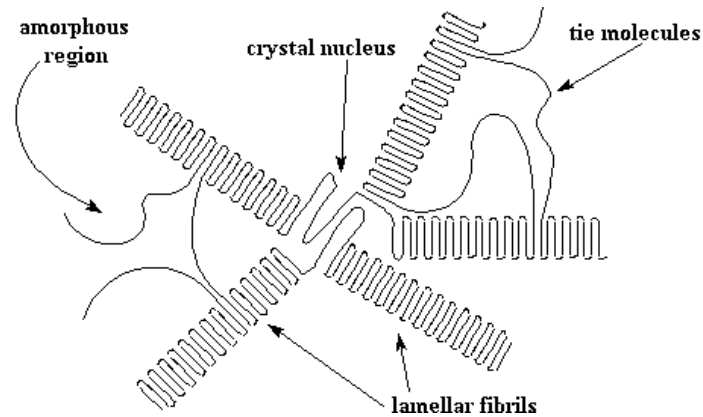

Figure 2.13 A polymeric spherulite composed of long molecules.³¹

2.5.2 Effect of Polymer Crystallinity on Fracture Resistance

Under favorable conditions, some polymers cooled from melt can organize into regular crystalline structures. High thermal energy favors a large number of conformations in the melt state, but upon cooling, the lower-energy conformations are favored, and the polymer chains can become organized. One of the ways that polymer chains can organize is into spherulites, which consist of crystalline lamellae or fibrils radiating from a common center (Fig. 2.13).³² The size and number of these spherulites have a great effect on the fracture resistance of the polymer. Many studies have shown that impact resistance is inversely related to spherulite size.³³ Failure sites are found at boundary surfaces of lamellae in spherulites; single large failure sites where fracture energy is concentrated promote much more microcrack initiation than does a distribution of many small sites where energy dissipation occurs in a larger volume of material. Within limitations, spherulite size can be controlled through processing conditions in order to obtain the desired properties. Stretch-blow molding is a common method of processing polyethylene terephthalate (PET) that allows the fracture resistance of the

material to be maximized. If the melt is cooled slowly, large spherulites form, but if the cooled solid is reheated to above its glass transition temperature (95-100°C for PET) and then stretched, stress induced lamellar crystals form instead of spherulites. The material is then much stronger than either the amorphous or the spherulitic crystalline forms (Table 2.3).³⁴

Table 2.3 Effects of varying crystallinity in PET.

Process	Crystallinity	Tensile Strength (MPa)
Quench	Amorphous	55
Cool Slowly	Large Spherulites	170
Biaxially Stretch	Lamellar Crystals	350

2.5.3 Effect of Polymer Orientation on Fracture Resistance

In addition to imparting a type of crystalline structure, stretching a polymer at a temperature just above its glass transition will also cause the chains to orient, or align to be more parallel with the axis of dominant tension. At this temperature, the free energy barrier is favorable for chain segment alignment. Covalent bonds require greater energy to cause scission than chain disentanglement does, thus orientation results in specific planar directions where fracture is more favorable.³⁵ Polymer films are often biaxially oriented in order to gain a measure of fracture resistance along more than one axis.

2.5.4 Effect of Polymer Thickness on Fracture Resistance

Once the material properties of a polymer have been maximized, the geometry of the end product can also be altered in order to affect the fracture resistance of the system. A recent study has shown that there is a strong dependence of the specific essential work of fracture value (the work required to fracture the polymer in its process zone) on specimen thickness for specimens of acrylonitrile-butadiene-styrene (ABS) less than 5mm thick. It was found that as the thickness increased (up to 5mm), the fracture toughness decreased.³⁶ A possible explanation for this is that there was an improvement in the energy absorbing capability of the polymer resulting from fundamental changes in the micro-mechanical deformation modes resulting from the decreased layer thickness.³⁷

2.5.5 Effect of Layering on Fracture Resistance

One way to achieve the effects of this decreased layer thickness without changing the dimensions of the overall part is to have multiple layers. Layered structures with enhanced properties can be seen both in nature and in synthetic materials. The fracture toughness of the nacre covering the inside of an oyster shell is substantial due to its layered structure. Similarly, the Japanese have fabricated laminated steels for centuries for use in their traditional swords. These swords are strong in compression and tough enough to absorb the energy of blows without breaking.³⁸

The application of layered structures to polymers can be achieved through a coextrusion process. Many layers of either the same, or different polymers can be extruded into one sheet or tube. It has been reported that coextrusion of the same material in all layers can increase tear and dart properties by 10%.³⁹ Layering ductile and hard

polymers can also have very positive effects. The impact resistance is increased due to the inhibition of crack propagation in the ductile component, while the strength of the hard component increases due to the thinness of its layers (compared to a single layer system of the same overall dimensions.)⁴⁰

The mechanical properties of layered composites, such as those described above, are defined by an appropriate average of the properties of the individual materials comprising the structure. These averages can be derived by referring to Fig. 2.14. In the figure, the composite consists of N layers of materials α and β of thicknesses l_α and l_β , respectively. The entire structure, with a length and width of L , is subjected to a tensile force of F . The volume fractions (V_α and V_β) of the two materials are:

$$V_\alpha = \frac{l_\alpha}{(l_\alpha + l_\beta)} \quad V_\beta = \frac{l_\beta}{(l_\alpha + l_\beta)} \quad (9)$$

When the tensile force is applied normal to the broad faces of the layers, as in Fig. 2.14a, each layer experiences the same stress (F/L^2) as the composite, but different strain. Conversely, if the tensile force is applied as in Fig. 2.14b, each layer experiences the same strain as the composite, but different stress. In this case, the sum of the forces on the individual layers ($F_\alpha + F_\beta$) is equal to the total external force, F . The composite stress, σ_c , can then be derived by obtaining the stress on each α and β layer (σ_α and σ_β), adding them, and substituting in Equation 9.

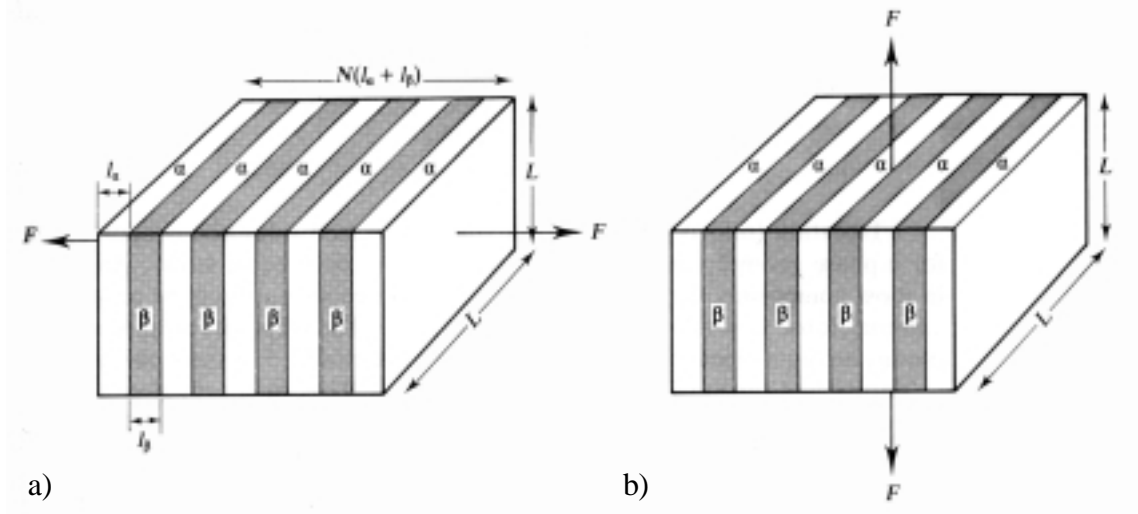

Figure 2.14 Composite structure having layers of two different materials (α and β). A tensile force (F) is applied normal to the broad faces of the layers in a) and perpendicular to them in b).⁴¹

The resulting equation for the total stress on a composite subjected to a tensile force perpendicular to the broad face of its layers is:

$$\sigma_c = \sigma_\alpha V_\alpha + \sigma_\beta V_\beta \quad (10)$$

Thus, the properties of a layered composite are highly dependent on the location of the applied stress. The geometry of the composite is also important. In this investigation, the geometry used was a thin-walled, multilayered cylinder. As seen in Fig. 2.15, both of the principle stresses experienced by a thin-walled cylinder, such as an angioplasty balloon, are applied perpendicular to the broad faces of the layers, like those in Fig. 2.14b.

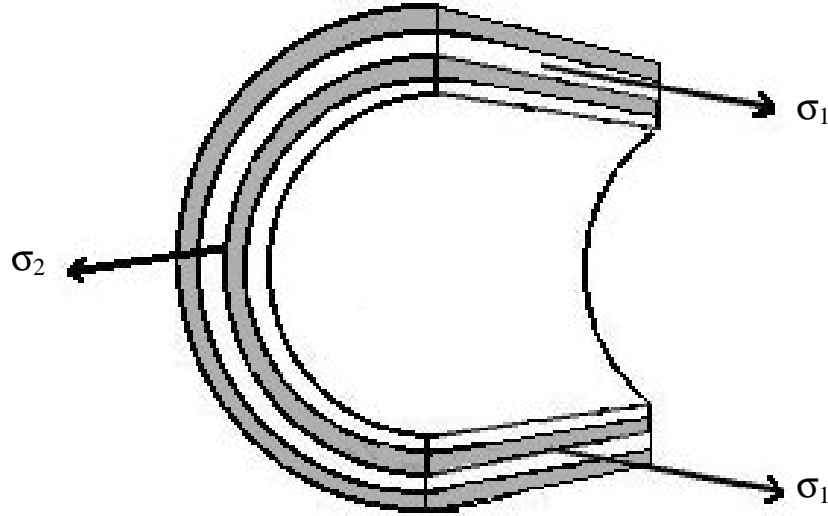

Figure 2.15 Sectional view of a multilayered, thin-walled cylinder experiencing circumferential (σ_1) and longitudinal (σ_2) stresses perpendicular to the broad faces of its layers.

Hence, the combination of equations 5, or 6, and 10 will result in the total circumferential, or longitudinal, stress experienced by a cylindrical, multilayer, thin-walled vessel, respectively (Eq. 11 and 12).

$$\sigma_1 = \sum_{a=1}^q \left[\left(\frac{pr_a}{t_a} \right)_{\alpha} \right] V_{\alpha} + \sum_{b=1}^n \left[\left(\frac{pr_b}{t_b} \right)_{\beta} \right] V_{\beta} \quad (11)$$

$$\sigma_2 = \sum_{a=1}^q \left[\left(\frac{pr_a}{2t_a} \right)_{\alpha} \right] V_{\alpha} + \sum_{b=1}^n \left[\left(\frac{pr_b}{2t_b} \right)_{\beta} \right] V_{\beta} \quad (12)$$

With the variables defined as follows:

σ_1 = circumferential stress

σ_2 = longitudinal stress

a = the number of layers of α material

q = the last layer of α material

b = the number of layers of β material

n = the last layer of β material

t = the thickness of layer a or b

r = the inner radius of layer a or b

V = volume fraction of α or β

p = the internal pressure of the vessel

Likewise, the yield stresses of a thin-walled, multilayer cylinder can also be predicted. The combination of Eq. 8 and Eq. 11 (with the variables all as previously defined) results in the following equation for the yield stress in a thin-walled, multilayer cylinder:

$$Y = \left(\frac{\sqrt{3}}{2} \right) \left\{ \sum_{a=1}^q \left[\left(\frac{pr_a}{t_a} \right)_{\alpha} \right] V_{\alpha} + \sum_{b=1}^n \left[\left(\frac{pr_b}{t_b} \right)_{\beta} \right] V_{\beta} \right\} \quad (13)$$

This equation can be used to predict the affect that increasing the number of layers has on the yield stress of an angioplasty balloon. Table 2.4 shows theoretical yield stress values for the balloons used in this investigation. All balloons had an 80/20 ratio of PET to Hytrel[®] (the alpha, and beta layers, respectively), and all had the same overall inner and outer diameters. It can be seen that the yield stress is expected to increase as the number of layers increases. This increase in yield stress corresponds to an increase in puncture resistance, as the balloon can withstand a higher load before fracturing.

Table 2.4 Calculated theoretical yield stress values for 80/20 PET/Hytrel[®] angioplasty balloons built to the same overall dimensional specifications and inflated to 370psi.

Number of Layers	Thickness of Alpha Layers (in)	Thickness of Beta Layers (in)	Yield Stress (psi)
2	0.0164	0.0041	2900
12	0.0040	0.0007	17000
20	0.0016	0.0004	27000

It should be noted that the contribution of the interfaces between the layers was not considered in the previous stress analysis of multilayered materials. Classical lamination theory (CLT) only allows for stresses in the plane of the laminate, and does not take interlaminar stresses into account.⁴² This neglect was not a concern of this

investigation for two reasons. The first reason was that interlaminar stresses contribute to the failure of multilayer materials mainly through free-edge delamination. The geometry of an angioplasty balloon does not lend itself to this sort of failure because there are no free edges in the region subjected to stress. Secondly, because the coextrusion process requires stringent laminar flow and short processing times, two miscible polymers, such as PET and Hytrel[®], are subject to minimal mixing. There is a small amount of diffusion of the macromolecules of the polymers when they do come in contact, thus preventing failure through delamination of the layers, but a significant interlaminar region does not develop due to the short processing times.⁴³ Thus, as interlaminar stresses are not believed to contribute to the failure of the materials used in this investigation, and there is no development of a significant interlaminar region, the contribution of the interfaces in this investigation will not be taken into account.

Because of its yielding behavior, and other desirable properties available through the combination of dissimilar polymers into one end product, multilayer technology is used widely today in the food industry for items such as ketchup bottles and packaging films. It has not been employed to great extent in the medical device industry, though its potential is promising.

2.6 Objectives

The objectives of this investigation were to:

- Design tubes that result in several different configurations of angioplasty balloons comprised of the same ratio of PET to a Hytrel[®]
- Fabricate balloons from these tubes
- Test these balloons for burst strength, puncture resistance, and compliance
- Correlate the balloon properties to the material configuration

3.0 Materials and Methods

3.1 Materials

All of the balloons fabricated in this investigation were comprised of the same materials. There was an 80/20 wall thickness ratio with the 80% being comprised of 95% Shell Cleartuf[™] 8006 Polyethylene terephthalate (PET) (Fig. 3.1) and 5% Dupont Selar PT4234, a toughened homopolymer polyester.

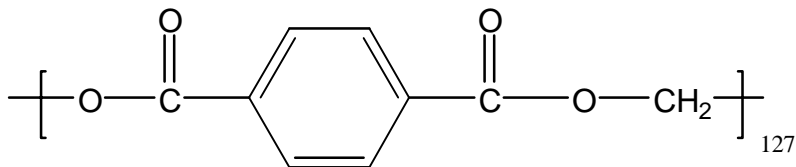

Figure 3.0.1 Chemical structure of Shell Cleartuf™ 8006

The 20% was comprised of 80% Dupont Hytrel® 5556 and 20% Dupont Hytrel® 7246. All grades of Hytrel® are block copolymers, consisting of a hard segment of polybutylene terephthalate and a soft segment based on long-chain polyether glycols. Each grade has specific properties determined by the ratio of soft to hard segments and by the make-up of the segments (Table 3.1). All of these materials are currently used by Boston Scientific, as discussed previously. For that reason, adhesion of the layers comprising the multilayer balloons in this investigation was not an issue.

Table 3.0.1 Properties of the materials used in this investigation, from Dupont and Shell product literature. The Cleartuf properties are for the amorphous state.

Property	Hytrel 5556	Hytrel 7246	Cleartuf
Melting Point	201°C	217°C	255°C
Yield Strength	250 psi	500 psi	8600 psi
Ultimate Elongation	560%	420%	450%

3.2 Tube Configurations

Three different balloon tube configurations were employed. The control had two layers (like a product currently on the market) and there was also a twenty-layer, and a twelve-layer composition (Fig. 3.2). Tubes were designed by employing the spreadsheet

calculations discussed in the Background section of this paper. Because it was not known if the 8/2 stretch ratio is ideal for balloons of more than two layers, initially five different tube dimensions with twelve layers were used; two with the top number of the stretch ratio (CIRG) varied, two with the bottom number of the stretch ratio (Q) varied, and one as the control.

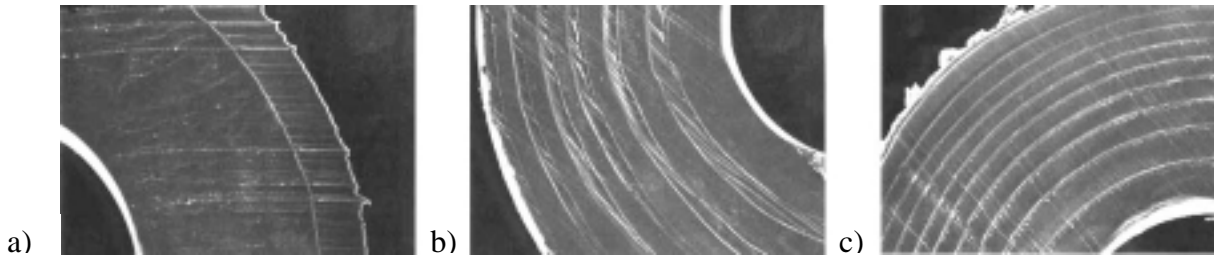

Figure 3.0.2 SEM micrographs of cross-sections of a) two-layer, b) twelve-layer, and c) twenty-layer 80/20 PET/Hytrel[®] 5mm balloon tubes (150x)

The tubes were designed to produce 5-4/5 (5mm wide by 4cm long) balloons. These balloons should have a double wall thickness of 1.6-2.5mils and an outer diameter of approximately 0.197in while holding 125psi.

3.3 Balloon Fabrication

After the tubes were obtained, balloons were fabricated through the process of tube crystallization, free-blowing, and heat setting of balloons. Because the ideal procedure for the two-layer balloons is known, that was used as the basis for the other two configurations. Adjustments were necessary in order to achieve balloons of the correct dimensions and thickness.

3.3.1 Tube Crystallization

Tube crystallization began by threading steel mandrels into the tubes so that they would not collapse. The tubes were then placed on blocks heated to 160°C (their crystallization temperature) for approximately 180s. These blocks had a gap of approximately 0.8in. At the end of the process, the tubes were sufficiently crystalline that they would not expand, except for the small amorphous segment left in the center. The mandrels were then removed.

3.3.2 Free-Blowing of the Balloon

Once the tubes were crystallized, they could be free-blown into balloons. The balloon machine was initially set with the parameters seen in Table 3.2 and then adjusted until acceptable balloons of each different tube configuration could be made repeatedly.

Table 3.0.2 Initial balloon machine parameters used to fabricate multilayer balloons.

Machine Parameters		N2 Pressures	
Bath Temperature	95C	INFL 1	185psi
Gripper Pressure	60psi	INFL 2	30psi
Pump Speed	40%	Move Speeds	
Cone Distance	2.45in	Move 1, Left	1.5 in/s
Timing Delays		Move 1, Right	1.5 in/s
Soak Time	10s	Move 2, Left	5 in/s
Move 1	.8s	Move 2, Right	4 in/s
Move 2	1s	Move Distances	
INFL 1	0s	L Move 1	.2 in
INFL 2	1.4s	R Move 1	.2 in
		L Move 2	1.05 in
		R move 2	1 in

3.3.3 Heat-Setting of the Balloon

After balloons could be free-blown in a repeatable manner, they had to be heat-set. The mold heat-set parameters used are seen in Table 3.3.

Table 3.0.3 Heat-set machine parameters used to fabricate multilayer balloons.

Low Draw	3 psi
High Draw	13 psi
Inflation A	35 psi
Inflation B	150 psi
Inflation C	150 psi
Inflation D	150 psi
Temp. Set Point	170C
Heat Time	30s

3.4 Balloon Verification

Once a number of balloons were heat-set, they were put through an initial verification process to ensure that they met some base criteria. First, the thickness of 10 balloons was measured with a micrometer to ensure that they were within the acceptable range of 1.6-2.5mil (double wall.) Next, one end of the balloon was heat-sealed and the other end attached securely to a pressurized nitrogen source. The balloons were then placed in a water bath at 37°C and inflated to 125psi (Fig. 3.3). Once at this pressure, the outer diameter of each balloon was measured with a laser micrometer to ensure that it was approximately 0.197in.

The last test in the verification process is for burst pressure. Following the outer diameter check, each balloon was inflated at 20psi/s until it burst, and that pressure was noted. An acceptable burst pressure was approximately 350psi.

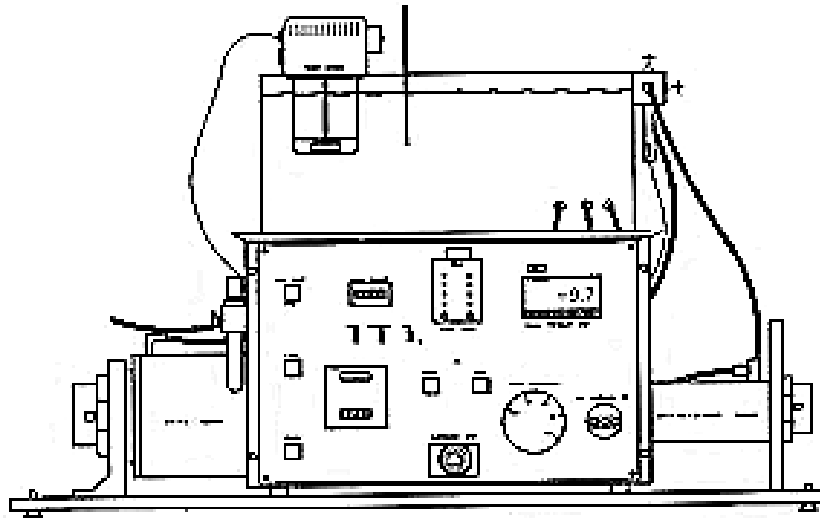

Figure 3.0.3 Heated water bath with pressurized lines to attach angioplasty balloons to for verification tests.⁴⁴

These steps were first done with the 80/20 twelve-layer extrusion with the control stretch ratio. Twelve-layer groups with other stretch ratios were then used to determine which stretch ratio gives the highest burst pressure and puncture resistance. Twenty-layer tubes were then designed with that stretch ratio, and balloons fabricated. Two-layer tubes were fabricated as controls for each set of tubes.

3.5 Testing of Balloon Properties

After a particular group of balloons passed verification, at least 15 more balloons were fabricated. Ten of those balloons were used to test for puncture resistance, and five were used to test the compliance of the balloon.

3.5.1 Puncture Test

In order to be tested for puncture resistance, one end of each of ten balloons was heat-sealed. An Instron Tension/Compression Tester was set up with a 10lb load cell and the Puncture Test Fixture was attached to the Instron (Fig. 3.4). This fixture was set up according to the standard procedure used at Boston Scientific. This same procedure was referenced in the actual testing of the balloons.⁴⁵ Load versus displacement was plotted, the maximum load and displacement were recorded, and the toughness (the area under the curve) was calculated.

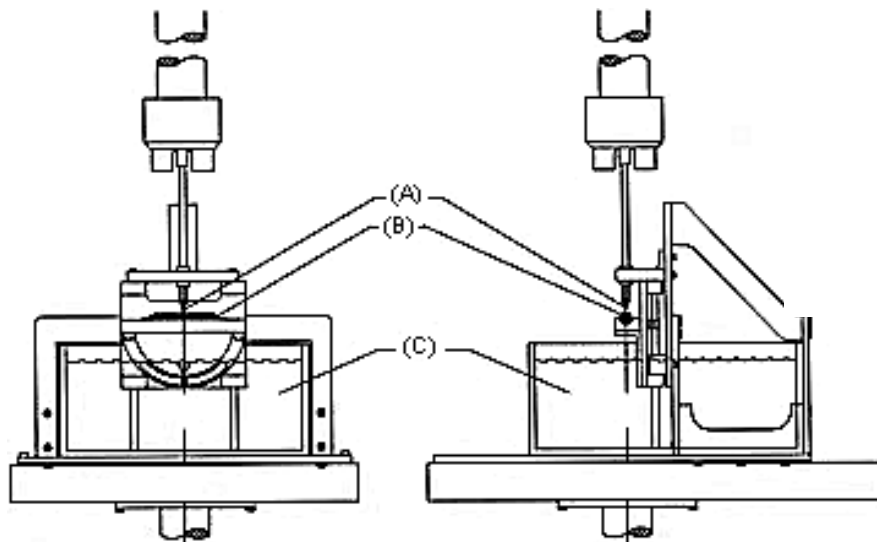

Figure 3.0.4 Fixture used with an Instron for puncture testing with (A) puncture tip, (B) balloon, and (C) heated water bath.³⁷

3.5.2 Compliance Test

Compliance testing was also carried out with balloons with one end heat-sealed. Each of five balloons, in turn, was securely attached to a pressurized nitrogen source and placed in a 37°C water bath (as seen in Fig. 3.3). They were then pressurized from four to twelve atmospheres. The outer diameter (OD) of the balloon was measured with a laser micrometer at each atmosphere and all of the values were recorded. The average percent change in OD was calculated as:

$$\%OD = \frac{(OD_{\max} - OD_{\min})}{OD_{\min}} * 100 \quad (14)$$

4.0 Results and Discussion

This investigation proceeded by using the ratio and materials previously discussed to first design and fabricate tubes, and then balloons, of twelve layers. These balloons were thoroughly tested in order to determine whether a different tube configuration than that traditionally used is necessary to optimize the properties of balloons with more than two layers. Following the selection of that tube configuration, twenty-layer tubes, and then balloons, were designed and fabricated based on the previous results. These balloons were also tested and compared with both twelve-layer and two-layer balloons. Conclusions were made based on the progression of events leading to the fabrication of an optimized twenty-layer balloon, and the analysis of how the balloon properties changed when the number of layers was increased.

Several outcomes were expected from this investigation. Because the PET is the load-bearing layer, it seemed that the burst pressure of the multilayer balloons would be decreased from that of the two-layer because there was not as much PET close to the core of the balloon, where the pressure is. Conversely, the puncture resistance of the multilayer balloon was expected to improve because the resistant Hytrel[®] layers were broken up by PET and would not be punctured all at once, thus dissipating the energy of crack propagation. It was not known whether there would be a measurable difference between the twelve and twenty-layer balloons.

4.1 Ideal Stretch Ratio Determination for Twelve-layer Balloons

Initially, 5 different lots of 80/20 PET/Hytrel[®] twelve-layer 5mm balloon tubes were extruded. Each lot had a different stretch ratio (Table 4.1). These stretch ratios were chosen by starting with the ratio of the control, and varying either the top or bottom number of the ratio slightly. Balloons were fabricated out of all of these lots, and these balloons were characterized by thickness, burst pressure, and puncture resistance. A lot of two-layer control tubes was also completed.

Table 4.1 Stretch ratios used in the fabrication of twelve-layer balloons, along with lot numbers identifying groups of tubes, and tube inner and outer diameters (ID and OD) in thousandths of an inch (mils).

Lot #	Tube ID	Tube OD	Stretch Ratio
1	0.063	0.027	7.22/1.82
2	0.065	0.024	8.12/1.82
3	0.056	0.027	7.22/2.46
4	0.052	0.027	7.22/2.99
5	0.068	0.024	8.12/1.82
control	0.063	0.027	7.22/1.82

The results of all of these tests were analyzed in order to determine the best stretch ratio for the twelve-layer tubes. Ideally, one lot would have an improved puncture resistance with comparable burst strength to the control. This was not entirely true. The first observation concerned the double wall thickness (Tc) of the balloons. The specification for the type of balloon being made for this project is 1.6-2.5mil. This was the first criterion to be met in the fabrication of all balloons (Table 4.2). While all lots did yield balloons within the specification, it was extremely difficult to accomplish with lots 4 and 5. (5 also had high standard deviations and was excluded from further consideration.) This fact corresponds to limitations in the stretch ratios that can be used for this size balloon.

Table 4.2 Average double wall thickness (Tc) of twelve-layer balloons in thousandths of an inch (mils), along with lot numbers identifying groups of tubes. Each Tc value corresponds to the average from 10 balloons tested.

Lot #	Tc
1	2.06
2	2.13
3	1.67
4	1.64
5	2.35

Burst pressures and puncture resistances of all of the balloons fabricated were analyzed (including the use of t-tests to determine significant differences.) It can be seen that, of all of the lots that could be accurately compared, 2 exhibited the best properties (Table 4.3). This is probably due only to the fact that 2 was the lot with the highest Tc, but because each Tc is unique to each lot, and all were within the acceptable range, it is valid to make conclusions about which lot has the best properties.

Table 4.3 Properties of balloons fabricated from twelve-layer tubes. Each value is the average from 10 balloons tested.

Lot #	Burst (psi)	Toughness (lb*in)	Puncture (lbf)
1	319.0	0.1540	3.903
2	355.0	0.1460	3.843
3	255.2	0.0831	2.524
4	290.2	0.0680	2.376

4.1.1 Additional Stretch Ratio Manipulation

It was decided that the next step would be to try to manipulate the stretch ratio further to obtain even better properties. The first consideration in this was to design tubes that would lead to balloons that fell in the center of the Tc specification. It was determined that there is a direct correlation between the wall thickness of the initial tube and the Tc of the resulting balloon (Fig. 4.1).

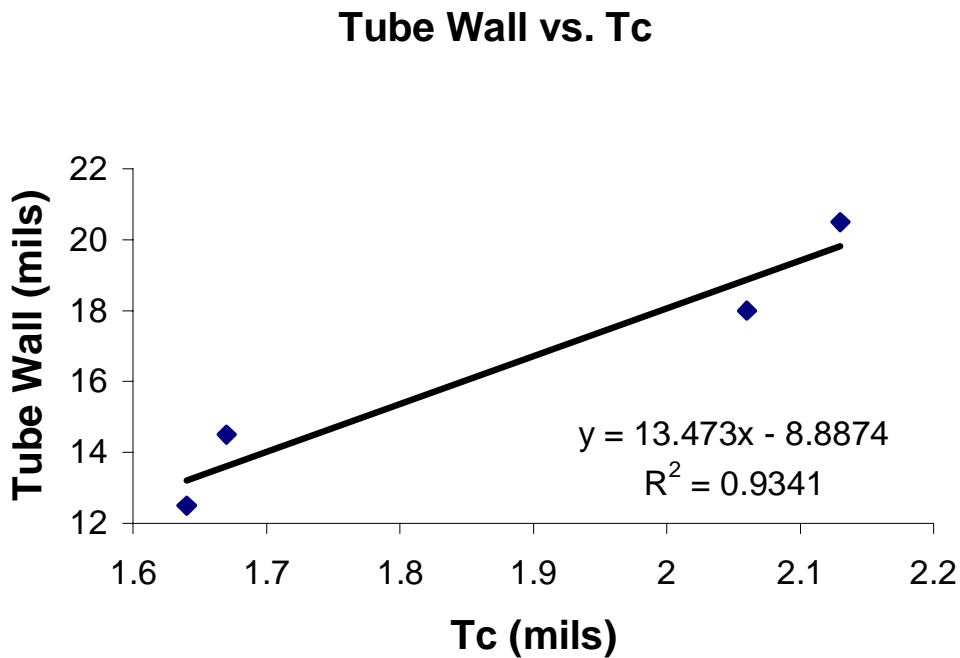

Figure 4.1 Thickness of tube wall versus double wall thickness (Tc) of the resulting balloon. Data used was obtained from twelve-layer balloons previously fabricated.

The equation of the resulting line was used to make an approximation of Tcs for balloons fabricated from tubes designed with more drastic deviations in the stretch ratio. New tube designs were examined that had a decreased inner diameter (ID), while keeping

a tube wall thickness approximately the same as lot 2 (which would lead to the desired Tc.) A decrease in the inner diameter of the tube leads to an increase in the top number of the stretch ratio (CIRG), which seemed desirable, based on the data already obtained. Figures 4.2 and 4.3 show that Tc is not related to CIRG, but as Tc increases, Q (the bottom number of the stretch ratio) also must increase slightly. For that reason, the new tubes that were designed had not only the desired increase in CIRG, but also a slight increase in Q (both with respect to the control and the ratios already experimented upon.)

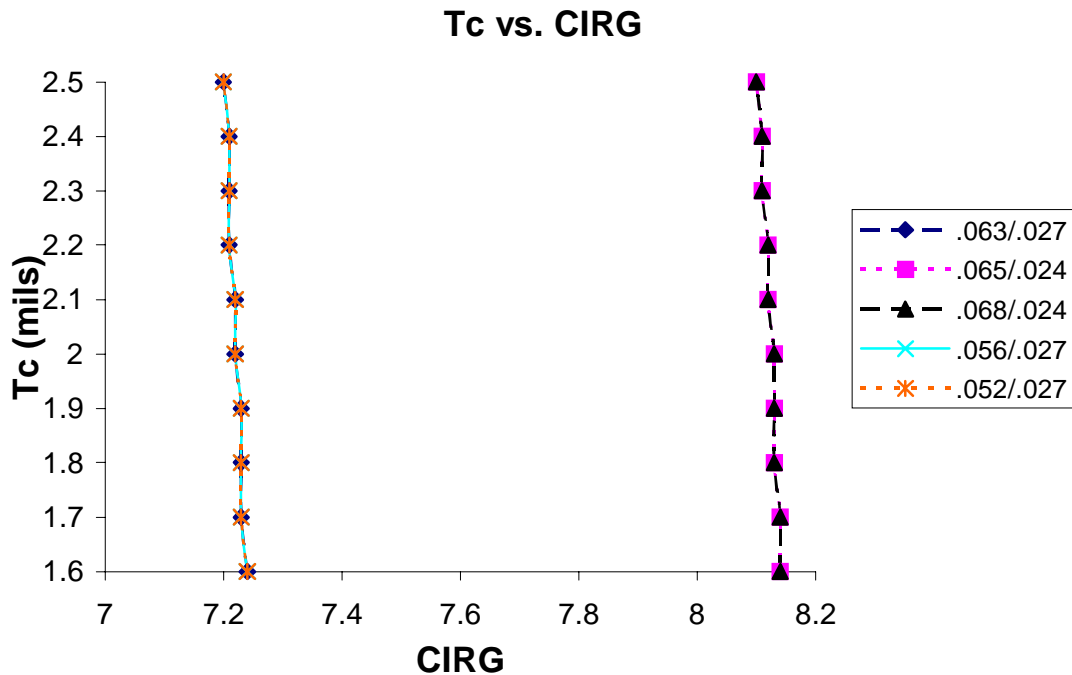

Figure 4.2 Double wall thickness of balloons (Tc) versus the top number of their corresponding stretch ratio (CIRG). Data were calculated for theoretical Tcs within the accepted 5mm balloon specification with tube dimensions previously used for twelve-layer tubes.

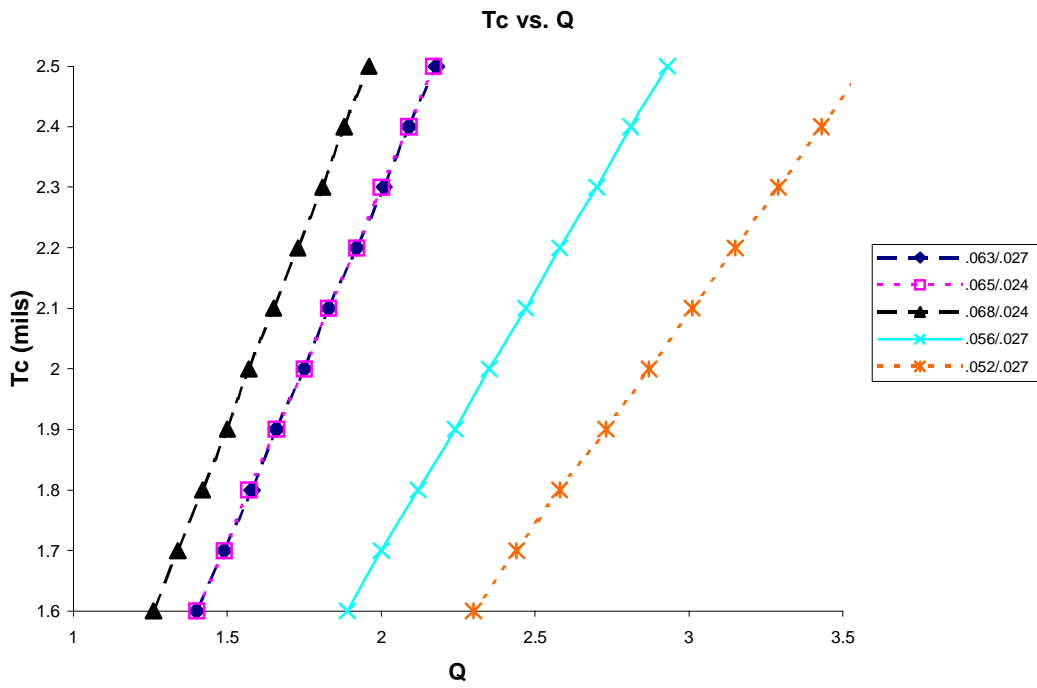

Figure 4.3 Double wall thickness of balloons (T_c) versus the bottom number of their corresponding stretch ratio (Q). Data were calculated for theoretical T_c s within the accepted 5mm balloon specification with tube dimensions previously used for twelve-layer tubes.

4.1.2 Failure of Tubes with New Stretch Ratios

Three new lots of twelve-layer balloon tubes were designed and extruded according to the guidelines defined above (Table 4.4).

Table 4.4 Stretch ratios used in the fabrication of additional twelve-layer balloons, along with lot numbers identifying groups of tubes, and tube inner and outer diameters (ID and OD) in inches. Approximate Tc is the double wall thickness of the balloons (in mils) calculated during the design of the tubes.

Lot #	Tube OD	Tube ID	Stretch Ratio	Approx. Tc
6	63	23	8.47/2.03	2.2
7	60	21	9.28/2.42	2.1
8	58	19	10.26/2.81	2.1

Several problems arose when attempts were made to fabricate balloons from these tubes. The first lot, 6, yielded balloons with slightly lower diameters than desired, and lot 7 resulted in balloons with a smaller than desired diameter that began to have layer separation during heatsetting. Some balloons entirely delaminated in the heatset, resulting in what appeared to be a balloon within a balloon. All balloons fabricated from the third lot, 8, split during heatsetting.

An attempt was made to determine the cause of this phenomenon. The first step was to examine the balloons and tubes under low magnification. Nothing abnormal could be seen in the balloon film, or in the tubes. It was concluded that the inability to radially expand significantly enough due to the extreme stretch ratios contributed to the splitting of the balloons. Burst strength and puncture resistance results were obtained for lots 6 and 7, but were discounted due to high standard deviations and difficulty in balloon fabrication.

4.1.3 Selection of the Ideal Stretch Ratio for Multilayer Balloons

The results obtained from experimentation with 8 lots of twelve-layer balloon tubes with differing stretch ratios were examined. The desired characteristics were an improvement in puncture resistance without a loss of burst strength, while staying within the dimensional specifications for a 5mm balloon. While no new ratio showed outstanding improvement over the standard 7.22/1.82, the 8.12/1.82 of lot 2 was slightly better in terms of yielding balloons consistently within the dimensional specifications, with high burst strength and puncture resistance values. All subsequent multilayer tubes were to be extruded with that new stretch ratio.

4.2 Twenty-layer Balloons

After the completion of the twelve-layer stage of the multilayer balloon experimentation, twenty-layer tubes were designed with the desired stretch ratio, as described above. It was expected that these tubes could be processed much the same as their twelve-layer predecessors, and so attempts were made at balloon fabrication starting with the previously used balloon machine set-up. All attempts to manipulate the set-up failed to result in any expansion of the balloon tube. This was surprising, as the materials and ratio of materials had not been changed, and, in fact, had been used by Boston Scientific for many years without problem.

4.2.1 Effect of Extrusion Parameters on Balloon Characteristics

In order to determine the cause of this inability to expand, the extrusion run parameters from previous lots of multilayer tubes were examined. It was found that the main differences in the lots were in the line speed. The slower line speed of the new lot of tubes suggests that they would not expand because they became too oriented during the extrusion process. The slower the line speed, the more time it takes the hot material to get from the extruder to the quenching water bath, and the more oriented it can become. As a result of this realization, three new lots of twenty-layer 80/20 tubes were extruded to observe how extrusion parameters affect balloon properties (Table 4.5).

Table 4.5 Lot numbers of tubes extruded with variations in extrusion parameters. Line speed is in feet per minute, and head temperature is in degrees Fahrenheit. Lot 9 is the initial lot of tubes that would not expand during balloon fabrication.

Lot #	Line Speed	Head Temp.
9	38	500
10	72	500
11	72	530
12	55	530

Balloons with comparable Tcs were made of all of the new lots of tubes; test results are as follows:

Table 4.6 *Properties of balloons fabricated from twenty-layer tubes with varying extrusion parameters. Each value is the average from 10 balloons tested.*

Lot #	Burst (psi)	Toughness (lb*in)	Puncture (lbf)	Compliance (%)
10	401.3	0.153	3.94	2.44
11	387.5	0.151	3.91	2.45
12	368.0	0.177	4.29	2.42

It can be seen that extrusion parameters do affect balloon properties. Tube lots 10, 11, and 12 were all made with the same ratio of the same materials, and the same number of layers, and used with the same balloon machine set-up. They resulted in balloons of the same wall thickness and diameter, but with different properties. The fact that the properties of lots 10 and 11 were not statistically different from each other (according to a Students t-test), but were different from lot 12 (except for compliance) suggests that the variation in line speed, and not the variation in temperature at the head of the extruder, is the cause of the observed differences in burst strength and puncture resistance.

4.2.2 Effect of Tube Orientation on Balloon Properties

As stated earlier, the main effect that this variation in line speed had on the resulting tubes was to orient them in the machine direction. The slower the line speed, the more the tubes become oriented. Because lot 12 was run at a slower line speed than the other two lots, it became more oriented. The increase in orientation is directly related to both the decrease in burst strength, and the increase in puncture resistance observed here. A 1999 study by Sauerteig and Giese indirectly related the distance between the cooling bath and the extrusion tooling (at a constant line speed) to the maximum burst pressure of

an angioplasty balloon.⁴⁶ Keeping the speed constant and changing the distance that the tubes travel before being quenched is essentially the same as changing the speed and keeping the distance constant, as this study has done. Sauertig and Geise found that shorter distances (less orientation) resulted in higher flexural strengths of the tubing, which, in turn, resulted in balloons with higher burst strengths. This agrees with the present study. The explanation for this phenomenon is related to the fracture mechanics of the oriented material, which also explains the observed increase in puncture resistance. When a balloon bursts, it generally does so longitudinally (in the machine direction), whereas when it punctures, small radial tears are observed. Studies have shown that orienting molecular chains perpendicularly to the crack path can enhance the toughness, or fracture resistance, of a material.⁴⁷ Because the orientation of the tubes in this study (and the resulting balloons) was increased in the machine direction by the change in extrusion line speed, the type of crack propagation seen during puncture was increasingly inhibited, but that seen during burst was not. Because all of the balloons had approximately the same T_c , thickness was not a factor in the experiment.⁴⁸

Although it is apparently very important, extrusion line speed has not been carefully observed at Boston Scientific in the past, as long as tubes of the correct dimensions were formed. It is possible that the polymer tubes are more sensitive to the orientation imparted to them by the changing line speed when they have an increased number of layers. The thinner the layers are, the easier it is for them to orient, and as the number of layers increases, each layer becomes thinner if the overall tube dimensions are kept constant. Because the tubes in this study were among the first extruded in a

multilayer configuration at Boston Scientific, the variation in balloon properties due to changes in the extrusion parameters may not have been previously noticed.

After all of the lots were tested, the properties of lot 12 were deemed the most desirable because they had the highest puncture resistance without significantly losing burst strength. All subsequent tubes were to be extruded with the line speed used for that lot.

4.3 Effect of Multilayer Structure on Balloon Properties

Once the processing of the multilayer balloons had been optimized, it was possible to compare test results of two, twelve, and twenty-layer balloons. Overall, test results have shown that increasing the number of layers in a PET/Hytrel[®] balloon while maintaining the same ratio of materials yields a greater puncture resistance while not significantly affecting the other desirable properties of the PET/Hytrel[®] balloon system.

4.3.1 Burst Strength

As stated earlier, a desired result of this investigation was that increasing the number of layers in the balloons would not adversely affect their burst strength. It was thought that the burst strength might decrease as the number of layers increased because less of the load bearing PET would be near the center of the balloon, where the stress was applied. Equation 13 (from section 2.5.5), along with yield stress values from the manufacturers of the polymers, (Table 3.1) was used to predict the pressure at which the balloons would yield during burst testing (Table 4.7).

Table 4.7 Predicted pressures at which 80/20 PET/Hytrel[®] balloons with different numbers of layers would yield during burst testing.

Number of Layers	Thickness of PET Layers (in)	Thickness of Hytrel Layers (in)	Pressure at Yield (psi)
2	0.0164	0.0041	321
12	0.0040	0.0007	217
20	0.0016	0.0004	132

It was predicted that as the number of layers increased, the pressure at which the balloons would yield decreased. Although the burst test done in this investigation reports only the pressure at which the balloons fail, and not the pressure at which they yield, the predicted values are still useful because all of the balloons must yield before they fail. If the pressure at which a balloon yields is lowered, than it is expected that the pressure at which it bursts is also lowered. Only a trend, and not precise pressure values could be predicted because the many different processes the polymers were subjected to greatly affected their orientation, which would affect their strength. While orientation was not taken into account in Eq. 13, it is directly related to the number of layers, and would not affect the predicted trend. In addition, the yield stress numbers used from the product literature were for amorphous polymers, while the actual polymers were biaxially oriented. This also would not affect the predicted trend because biaxial orientation would only increase all of the yield stress values.

In order to test the hypothesis that balloons with increasing numbers of layers would have lower burst strengths, two, twelve, and twenty-layer balloons of approximately the same wall thicknesses were tested to determine the maximum amount of pressure that they could hold without bursting (using the procedure discussed in

Section 3.4). Figure 4.4 shows the results of these tests. All balloons tested had comparable burst strengths that were sufficiently high enough to not be problematic in clinical use.

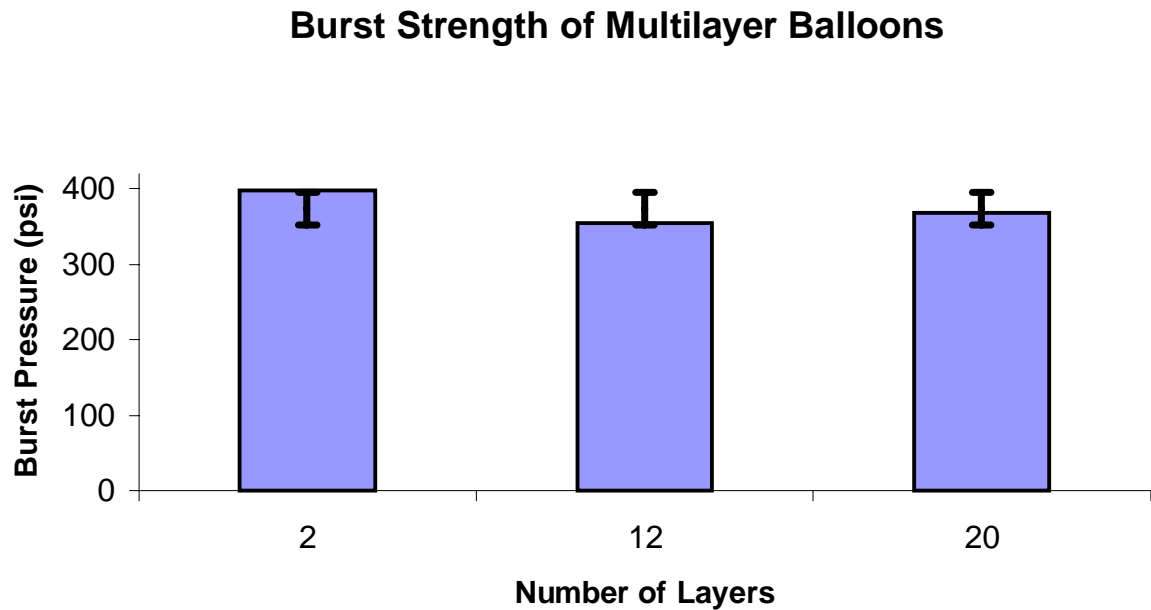

Figure 4.4 Burst strengths of 5mm 80/20 PET/Hytrel[®] balloons with an increasing number of layers. Each value is the average of 10 balloons tested. Error bars signify one standard deviation.

The predicted decrease in burst strength with an increasing number of layers was incorrect. A slight decrease was observed, but it was not statistically significant. It is possible that a decrease in yield strength does not directly correlate to a decrease in burst strength for the polymers used in this investigation. The fact that burst strength was not significantly affected by an increase in the number of layers of the balloons is probably due to the fact that there was the same amount of PET in all of the balloons and the interspersed layers of Hytrel[®] did not contribute to the impedance of crack propagation

during burst. This is corroborated by an earlier Boston Scientific investigation that found that a twelve-layer balloon containing only PET had approximately the same burst strength as a two-layer control balloon containing PET and Hytrel[®].⁴⁹ In addition, thinning out the layers of PET by increasing their number also did not have an effect on the strength, as has been known to happen with other materials.⁵⁰ It is probable that the amount of layering done in this investigation was not on the order necessary to cause the changes in micro-mechanical deformation modes that would affect the burst strength.

4.3.2 Puncture Resistance

While layering did not significantly affect the burst strength of the balloons fabricated, it did affect the puncture resistance and toughness. It was hypothesized that increasing the number of layers would increase the puncture resistance and toughness of the balloons because the resistant Hytrel[®] layers are broken up by the PET and would not be punctured all at once.

Two, twelve, and twenty-layer balloons of approximately the same wall thicknesses were tested to determine the maximum load that they could be impacted with before puncturing (using the procedure discussed in Section 3.5.1). It can be seen in Figs. 4.5 and 4.6 that the puncture resistance and toughness of the balloons increased linearly as the number of layers increased.

Puncture Resistance of Multilayer Balloons

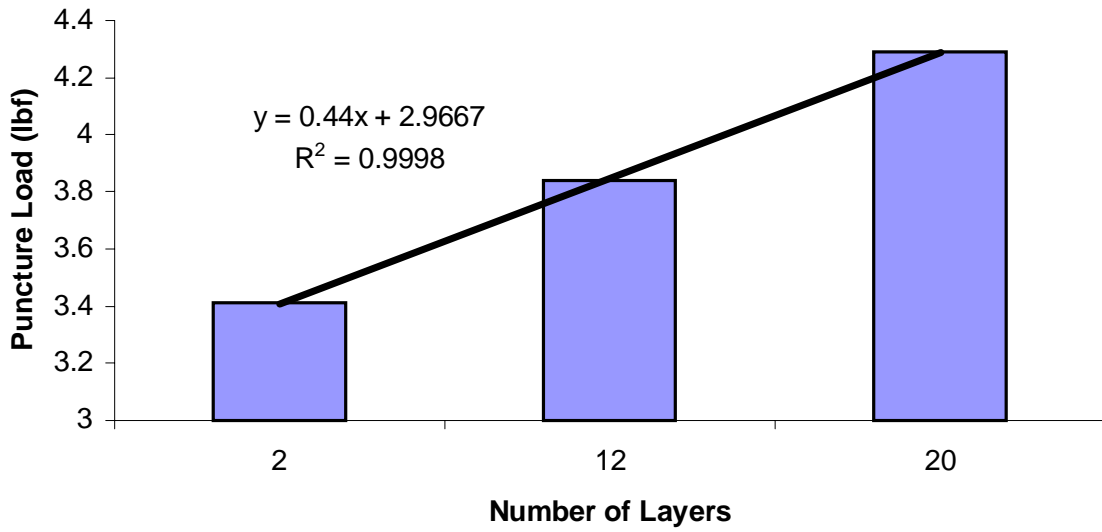

Figure 4.5 Puncture resistances of 5mm 80/20 PET/Hytrel[®] balloons with an increasing number of layers. Each value is the average of 10 balloons tested.

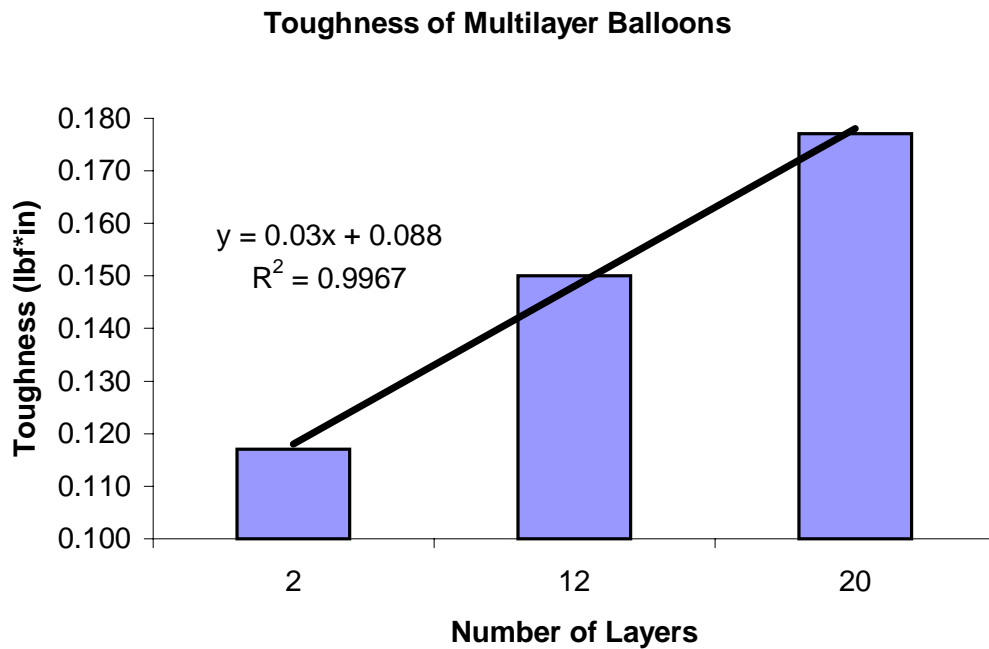

Figure 4.6 Toughnesses of 5mm 80/20 PET/Hytrel[®] balloons with an increasing number of layers. Each value is the average of 10 balloons tested.

This observation leads to the conclusion that, for this material system, the increase in the number of layers leads to an increase in the ability of the balloon to dissipate the energy of crack propagation during impact. It was hypothesized that this occurs because the ductile Hytrel[®] layers are interspersed with the hard PET layers, impeding any crack that travels through the PET at multiple intervals. The significance of the toughness value of the balloons is that not only does the increase in the number of layers lead to an increase in the load that the balloon can be impacted with before puncturing, but it also shows an increase in the deflection of the balloon wall before that puncture. This suggests that the thinning out of the layers increased their ductility, a phenomenon that has been observed in other polymer systems.⁵¹

There are many reasons why increasing the number of layers in the balloons may have led to an increase in their puncture resistance and toughness. The increase in toughness suggests that there was an increase in the non-essential work of fracture associated with the plastic deformation of the specimen, rather than solely an increase in the essential work of fracture associated with the actual tearing of the material. This is consistent with the given hypothesis as to the relationship between the layering and the observed properties of the balloons. As a load is imparted onto the balloon during puncture testing, microcracks begin to form in the material. In order for fracture to occur, these cracks must grow and lead to an actual rupture in the material and the creation of a new surface area at the site of the rupture. Crack growth must proceed through both the ductile and hard layers of the balloons, but because the layers are separate, though joined at interfaces, a crack cannot simply travel straight through the balloon wall. Instead, the energy of crack propagation is discontinuously dissipated by the different materials.

This phenomenon has been observed in previous studies in systems composed of multiple layers of polycarbonate (PC) and styrene-acrylonitrile copolymer (SAN). As a craze traveled through the layers, the plastic zone and elastic stress concentration of the craze tip would extend from the SAN layers into the ductile PC layers. This cooperative behavior would change the deformation mechanisms to help prevent brittle fracture and was dependant on the thickness of the layers.⁵² As in this investigation, as the number of layers increases, the amount of the ductile component of the system farther away from the initial impact increases. This leads to more dissipation of crack propagation energy throughout the entire thickness of the balloon because the ductile layers are the most responsible for retarding the fracture.

In addition, it is possible that the decrease in the thickness of the layers contributes to changes in the micro-mechanical deformation modes that allow for the increase in the essential work of fracture of the material. The increasing thinness of the layers leads to their becoming more oriented, and because the main direction of orientation of the balloons is in the direction perpendicular to the observed failure mode during puncture, an increase in orientation would lead to an increase in puncture resistance.

4.3.3 Compliance

Unlike puncture resistance and toughness, the compliance of balloons with an increasing number of layers was unchanged. Two, twelve, and twenty-layer balloons of approximately the same wall thickness were tested for the percent that they expand over a typical range of inflation pressures (using the procedure discussed in Section 3.5.2). All balloons expanded approximately 2.5%, which is normal for an unsterilized 5mm 80/20 PET/Hytrel[®] balloon. The fact that balloon compliance was unaffected by an increasing number of layers was expected because the balloons were not brought to failure, thus not necessitating the increased crack propagation impedance that layering imparts on the material system.

5.0 Conclusions and Recommendations

The objectives of this investigation were to design tubes that would result in several different configurations of angioplasty balloons comprised of the same ratio of

polyethylene terephthalate (PET) to Hytrel[®], fabricate balloons from these tubes, test the balloons for burst strength, puncture resistance and compliance, and correlate these properties to the material configuration of the balloons. Initially, tubes of 80/20 PET/Hytrel[®] with twelve layers were designed in order to determine the stretch ratio that would result in the balloons with the best properties. After balloons were fabricated and tested, it was found that a stretch ratio of 8.12/1.82 (circumferential growth/the ratio of circumferential growth to the longitudinal volume displacement factor) resulted in a higher puncture resistance and toughness, while maintaining a sufficient burst strength in comparison to balloons with the standard 7.22/1.82 stretch ratio.

Next, tubes of 80/20 PET/Hytrel[®] with twenty layers were extruded with the optimized stretch ratio and it became necessary to also optimize the extrusion parameters used in the fabrication of the tubes. After experimenting with different extrusion head temperatures and line speeds, it was determined that slower line speeds result in balloons with higher puncture resistance values because of the increase in orientation of the tubes. Optimized twenty-layer tubes were extruded, and balloons were fabricated.

Lastly, the properties of these twenty-layer balloons were compared with those of the optimized twelve-layer balloons, and two-layer balloons (the control). It was found that, although the burst strength and compliance of the balloons was not significantly effected, increasing the number of layers while keeping the ratio of materials constant lead to a linear increase in the puncture resistance and toughness of the balloons. This can be attributed to changes in the micro-mechanical deformation modes of the materials due to their increasing thinness as the number of layers increased, and also to the increased

distribution of the ductile component of the system that dispersed the energy of crack propagation.

Although the number of layers used in this investigation was limited by the extrusion equipment available, the linearity of the puncture resistance and toughness values obtained suggests that a further increase in the number of layers would result in angioplasty balloons with even higher values for these properties. Medical device companies are always looking for new ways to strengthen their balloons in the expanding market, especially with the trend towards stenting vessels inciting the need for increased puncture resistance, not only because of the possibility of calcified lesions rupturing the balloons, but also the ends of the metal stents pressing into the balloon as it expands.

This investigation shows that the Boston Scientific Corporation can improve one of the angioplasty balloons that it currently sells simply by changing the configuration of the materials, instead of having to research new medical grade polymers and how to process them. In the future, this multilayering technique should be investigated with other material systems that are also currently used. Improving the properties of angioplasty balloons is not only advantageous to the manufacturer, but also to the doctor that uses the balloons, and the patient that the balloons are used in.

6.0 References

- ¹ American Heart Association, 2001 Heart and Stroke Statistical Update, Dallas, Texas: American Heart Association, 2000.
- ² http://www.guidant.com/consumer/condition/coronary_angio.shtml (2001)
- ³ <http://www.hgcardio.com/ptca.htm> <http://www.hgcardio.com/ptca.htm> (2000)
- ⁴ Abele, J. *Balloon Catheters and Transluminal Dilatation: Technical Considerations*, American Journal of Radiology (1980) 901-906
- ⁵ Castaneda-Zuniga, W.R., et al., *The Pathologic Basis of Angioplasty*, Angiology **35** (1984) 195-205
- ⁶ Hodgson, John McB., *Focal Angioplasty: Theory and Clinical Application*, Catheterization and Cardiovascular Diagnosis **42** (1997) 445-451
- ⁷ Wolf, Gerald L., et al., *Potential Mechanisms of Angioplasty*, Cardiovascular and Interventional Radiology **7** (1984) 11-17
- ⁸ Oh, S., et al., *Finite-element Analysis of Balloon Angioplasty*, Medical and Biological Engineering and Computing **32** (1994) S108-S114
- ⁹ Hubner, Peter J.B., Guide to Coronary Angioplasty and Stenting, Harwood Academic Publishers: Amsterdam, 1998.
- ¹⁰ Castaneda-Zuniga, W.R., et al., *The Pathologic Basis of Angioplasty*, Angiology **35** (1984) 195-205
- ¹¹ Saab, Mark A., *Applications of High-Pressure Balloons in the Medical Device Industry*, Medical Device and Diagnostic Industry Magazine, September 2000, 86-96
- ¹² Pepine, Carl J., ed., Diagnostic and Therapeutic Cardiac Catherization, Third Edition, Williams and Wilkins: Baltimore, 1998.
- ¹³ Bach, Richard G., et al., *Effects of Percutaneous Transluminal Coronary Angioplasty Balloon Compliance on Angiographic and Clinical Outcomes* The American Journal of Cardiology **72** (1993) 904-907
- ¹⁴ Raymenants, E., et al., *The Impact of Balloon Material and Lesion Characteristics on the Incidence of Angiographic and Clinical Complications of Coronary Angioplasty* Catheterization and Cardiovascular Diagnosis **32** (1994) 303-309
- ¹⁵ Desmet, Walter J., et al., *Comparison of Clinical Complications, Angiographic Results, and Device Usage of Coronary Angioplasty Using Low- and High-Compliance Balloons*, Catheterization and Cardiovascular Diagnosis **41** (1997) 5-11
- ¹⁶ Hamilton, Bruce, et al., *Final Report for Colossal PTA Balloon Catheter™, Medi-Tech®, Balloon Material Choice*, Boston Scientific Corporation Corporate Technology Development Document #00241 (1997)
- ¹⁷ Noddin, R. *Blue Max Balloons: New Diameter Development*, Medi-tech Technical Note #M2000779 (1986)

-
- ¹⁸ Graham, L., and Kalashian, D. *PET Balloon Stretch Ratio Experiment*, Boston Scientific Corporation Technical Report #00180 (1997)
- ¹⁹ Golike, R.C., and Cobbs, Jr., W.H. *Crystallization of Copolymers of Ethylene Glycol and Diethylene Glycol Terephthalate*, Journal of Polymer Science **54** (1961) 277-285
- ²⁰ *Ibid.*
- ²¹ *Balloon Forming Machine*, Boston Scientific Drawing R840033-01 (1996)
- ²² Noddin, R. *Balloon Machine Setup*, Medi-tech Technical Note #M2000779 (1986)
- ²³ Buckley, C.P., and Salem, D.R., *High-Temperature Viscoelasticity and Heat-Setting of Poly(ethylene Terephthalate)* Polymer **28** (1987) 69-85
- ²⁴ Sichina, W.J. *DSC as a Problem Solving Tool: Measurement of Percent Crystallinity of Thermoplastics*, Perkin Elmer Thermal Analysis Application Note, 2000.
- ²⁵ Mehta, A., et al. *Equilibrium Melting Parameters of Poly(ethylene terephthalate)*, Journal of Polymer Science, Polymer Physics Ed. **16** (1978) 289
- ²⁶ Popov, E. P., Mechanics of Materials, Second Edition, Prentice-Hall, Inc.: New Jersey, 1976.
- ²⁷ Hibbeler, R.C., Mechanics of Materials, Third Edition, Prentice Hall, Inc.: New Jersey, 1997.
- ²⁸ Courtney, T.H., Mechanical Behavior of Materials, McGraw-Hill, Inc.: New York, 1990.
- ²⁹ Ragab, A., and Bayoumi, S.E., Engineering Solid Mechanics Fundamentals and Applications, CRC Press: London, 1999.
- ³⁰ Perkins, W.G. *Polymer Toughness and Impact Resistance*, Polymer Engineering and Science **39** (1999) 2445-2460
- ³¹ Odian, G. Principles of Polymerization, 3rd Ed. John Wiley & Sons: New York, 1991.
- ³² Freid, J.R., Polymer Science and Technology Prentice Hall Ptr: New Jersey, 1995.
- ³³ Perkins, W.G. *Polymer Toughness and Impact Resistance*, Polymer Engineering and Science **39** (1999) 2445-2460
- ³⁴ Morton-Jones, D.H., Polymer Processing, Chapman and Hall: London, 1989.
- ³⁵ Kubisiak, M.P., and Quesnel, D.J. *Interaction of Process Variables With the Fracture Behavior of Amorphous Polystyrene During Attrition*, Polymer Engineering and Science **36** (1996) 2253-2259
- ³⁶ Fasce, L., et al., *On the Impact Essential Work of Fracture of Ductile Polymers*, Polymer Science and Engineering **41** (2001) 1-14
- ³⁷ Mueller, C., et al., *Microlayer Coextrusion: Processing and Applications*, Polymer Process Engineering (1997) 95-103
- ³⁸ Baer, E., et al., *Microlayer Coextrusion Technology*, SPE ANTEC (2000)
- ³⁹ Taylor, J., and Baik, J. *Benefits of Coextruded LLDPE/LDPE Film Versus Blended LLDPE/LDPE Film*, SPE ANTEC (2000)

-
- ⁴⁰ Maiboroda, V.P., et al., *Mechanical Properties of Multilayer Materials*, Translated from Poroshkovaya Metallurgiya **5** (1982) 70-74
- ⁴¹ Courtney, T.H., *Mechanical Behavior of Materials*, McGraw-Hill, Inc.: New York, 1990.
- ⁴² Jones, R.M., *Mechanics of Composite Materials, Second Edition*, Taylor & Francis, Inc.: Pennsylvania, 1999.
- ⁴³ Cheng, J.F. *Mechanical Properties of Polyether-Polyamide Block Copolymers in Multilayer Tubing Structures*, Masters Thesis, MIT (2000)
- ⁴⁴ *Multi-Inflation Machine*, Boston Scientific Drawing E840042-00 (1996)
- ⁴⁵ Berry, M. *Puncture Test Fixture and Procedure*, Boston Scientific Machine Operation Specification Dwg. No. R841573-01 (1997)
- ⁴⁶ Sauerteig, K., and Giese, M. *The Effect of Extrusion and Blow Molding Parameters on Angioplasty Balloon Production*, Journal of Applied Medical Polymers **3** (1999) 11-14
- ⁴⁷ Karger-Kocsis, J., and Czigany, T. *On the Essential and Non-essential Work of Fracture of Biaxial – Oriented Filled PET Film*, Polymer **37** (1996) 2433-2438
- ⁴⁸ Maspoch, M., et al. *Essential Work of Fracture on PET Films: Influence of the Thickness and the Orientation*, Polymer Testing **19** (2000) 559-568
- ⁴⁹ Gibbs, K. *12 Layer Balloon Performance Summary*, Boston Scientific Internal Data (1999)
- ⁵⁰ Taylor, J., and Baik, J. *Benefits of Coextruded LLDPE/LDPE Film Versus Blended LLDPE/LDPE Film*, SPE ANTEC (2000)
- ⁵¹ Baer, E., et al. *Relationship of Hierarchical Structure to Mechanical Properties*, Macromolecular Symposium **147** (1999) 37-61
- ⁵² *Ibid.*