

**THE IMPACT OF USING AN OBSTACLE SENSING SYSTEM IN THE POWER
WHEELCHAIR TRAINING OF CHILDREN WITH DISABILITIES**

A Thesis

Submitted to the Faculty

of the

WORCESTER POLYTECHNIC INSTITUTE

in partial fulfillment of the requirements for the

Degree of Master of Science

in

Biomedical Engineering

by

Lisette Manrique

April 2005

APPROVED:

Allen Hoffman, Ph.D., Major Advisor
Professor
Mechanical Engineering, WPI

Kristen Billiar, Ph.D., Committee Member
Assistant Professor
Biomedical Engineering, WPI

Gary Rabideau, Committee Member
Director of Rehabilitation Engineering
Massachusetts Hospital School

Geoffrey Reinhold, Committee Member
Occupational Therapist
Massachusetts Hospital School

Abstract

Pediatric powered mobility training teaches a child useful skills to become effectively mobile with the aid of their powered wheelchair. The staff at the Massachusetts Hospital School (MHS) desired a powered mobility training protocol that could be used for training children who were considered to be marginal wheelchair drivers with respect to basic maneuvering skills. The primary objective of the protocol was to reduce the subject's reliance on verbal cuing and replace this dependence by external cues provided by the environment.

The specific aim of this pilot study was to investigate the use of a ranging device mounted on a powered wheelchair to provide an auditory feedback to the subject when an obstacle within its range was detected.

The first goal of this study was to verify that the ranging device was capable of providing useful auditory feedback to the MHS patients that had met criteria to be candidates for the study.

The second goal was to determine to what extent the device was beneficial in improving the subject's everyday mobility skills.

The final goal was to observe if there was an internalization of the ranging device cues such that the subject's mobility skills improved upon removal of the device.

Three subjects participated in this study. Each subject participated in pre-training, training and post-training evaluations through which the improvement of their mobility skills was measured.

The results of this pilot study demonstrated that the use of a ranging device, with auditory feedback, can potentially be used effectively in the powered mobility training of children with disabilities. Further, it appeared that marginal wheelchair drivers were able to internalize some of the ranging device's auditory cues such that their performance improved when the sensing device was removed from their wheelchair.

Recommendations for improving this study include using a more appropriate ranging device, redefining criteria for qualified candidates participating in the study, and eliminating variations in data between different evaluators.

Acknowledgements

I would like to offer my sincere thanks and appreciation to everyone who has helped and supported me throughout this project. First I would like to acknowledge all of the occupational and physical therapists of MHS who sacrificed their time to assist in collecting data for this study. Their genuine interest in investigating new ways to treat their patients is inspirational. Many thanks to the faculty, staff, and my fellow students of the Biomedical Engineering Department who have encouraged and motivated me along the way. Finally, a special thanks to the following people:

Prof. Allen Hoffman for mentoring me in being a better engineer and teacher, and for introducing me to the world of assistive technology.

Gary Rabideau and Geoff Reinhold for their constant support, smiles, and tireless efforts to make this project work. Thank you for taking the time to teach me about the clinical side of rehabilitation engineering.

Subjects 1, 2, and 3 for their patience, determination and willingness to be a part of this study.

Prof. Kris Billiar for joining my committee with only 2-weeks notice.

Jerry Potter, Director of Engineering at Rostra Precision Controls Inc., for generously donating sensing systems for use in this study. Thank you for having faith in a complete stranger and sharing a common desire to help people with disabilities.

And last, but not least, to all of my family and friends. Especially to my parents, my brothers, and Tejal for pushing me to get this far in the first place. Thank you for enduring the late-night typing and my borrowing of digital cameras for months at a time. I love you all.

Table of Contents

Abstract	i
Acknowledgements	ii
List of Figures	v
List of Tables.....	vi
Introduction	1
Background	3
The Value of Powered Mobility.....	3
Current Powered Mobility Training at Massachusetts Hospital School	4
Existing Wheelchair Mobility Training Protocols as Described in Published Literature.....	5
‘Smart’ Wheelchairs.....	12
Commercially Available Sensing Devices	14
Methodology	18
Study Participants and Qualifying Criteria	18
Selected Sensing Device: Rostra Obstacle Sensing System	20
Sensing Device Modifications for Use in Powered Mobility Training.....	22
Development of the Powered Mobility Training Protocol.....	27
Determination of Evaluation Paths	27
Stages of Powered Mobility Training and Data Collection Sheets.....	30
Pre-Training Evaluation	32
Powered Mobility Training Sessions	34
Post-Training Evaluations	36
Timeline of Case Study	37
Results	39
Case Study Results for Subject 1:	39
Case Study Results for Subject 2:	42
Case Study Results for Subject 3:	45
Discussion of Case Studies	49
Case Study Discussion for Subject 1:	50
Case Study Discussion for Subject 2:	53
Case Study Discussion for Subject 3:	55
Discussion	62
Discussion of the Powered Mobility Protocol and its Use.....	62
Conclusions	66
Recommendations for Future Work.....	68
Appendix A: Private Correspondence to the MHS Committee for Human Studies	72
Appendix B: Parental Consent Form	75
Appendix C: Private Correspondence to MHS Clinical Staff.....	78
Appendix D: Janeschild’s Student Information Form.....	81
Appendix E: Rostra Obstacle Sensing System Operating Manual	82
Appendix F: Student Information Forms for Subjects 1, 2 and 3	88
Appendix G: Wheelchair Skills Evaluation Forms	94
Appendix H: Completed Evaluation Sheets.....	98
Subject 1	98
Subject 2.....	109

Subject 3.....	118
References	128

List of Figures

Figure 1: WSTP Training Session Diagram	9
Figure 2: Wheelchair Skills Training Evaluation Scores for Control and WSTP Groups	11
Figure 3: ROSS setup on an automobile and detection zones.....	21
Figure 4: Outdoor walkway (pergola) at MHS lined with metal railings	23
Figure 5: ROSS sensor and metal shields	24
Figure 6: Portable sensing device, shown upside down.....	25
Figure 7: Functional orientation of sensing device mounted under a lap tray	26
Figure 8: Pre and Post-training Evaluation Path	28
Figure 9: Training Session Evaluation Paths	29
Figure 10: Subject 1, Time Comparison for Completion of Pre- & Post-Training Evaluation Path	41
Figure 11: Subject 2, Time Comparison for Completion of Pre- & Post-Training Evaluation Path	45
Figure 12: Subject 3, Time Comparison for Completion of Pre- & Post-Training Evaluation Path	48
Figure 13: MHS walkways lined with wooden panels during the winter months	57

List of Tables

Table 1: Commercially available reverse-sensing systems.....	15
Table 2: Key Issues for Reverse Sensing Systems.....	15
Table 3: Detection Zone Alerts	22
Table 4: Subject 1’s Wheelchair Skills Evaluation Form Results	40
Table 5: Subject 2’s Wheelchair Skills Evaluation Form Results	43
Table 6: Subject 3’s Wheelchair Skills Evaluation Form Results	47

Chapter 1

Introduction

Pediatric powered mobility training entails teaching a child useful skills to become effectively mobile with the aid of their powered wheelchair. At Massachusetts Hospital School (MHS), a residential school for children with disabilities, many patients rely on powered wheelchairs to be independently mobile. Each patient is taught how to use their powered wheelchair by a powered mobility training team that consists of the occupational and physical therapists that treat them. The training protocols that the therapists use are generally not standardized and instead are based upon common sense and intuition, rather than proven techniques (Appendix A). Training a child in cognitive vigilance and attention to task, which are necessary for safe and consistent driving, has proven to be a particularly difficult task. A common primary objective of MHS therapists is to reduce their patients' reliance on verbal cuing from an attendant and in its place to depend on external environmental cues. The patients can then utilize these external cues to alert themselves to obstacles and to refocus their attention on the driving task when they begin to stray from the intended path.

The specific aim of this pilot study is to investigate a technique through which a ranging device mounted on a powered wheelchair could be used in powered mobility training to provide an auditory feedback to the subject when an obstacle within its range is detected. Ideally, as the subject becomes more familiar with the manner in which the ranging device functions, the external cues produced by the device could potentially become more internalized and allow the subject to ultimately be more independent in driving.

The preliminary goal of this investigation is to verify that the ranging device is capable of providing useful auditory feedback to the MHS patients that have met criteria to be good candidates for the study. The broad population of patients at MHS has a primary diagnosis of physical disability, yet the subgroup of this population having neuromotor disabilities are of particular interest for this pilot study. Since the type and level of neuromotor disability vary significantly within this subgroup this precludes establishing a control group and instead a case study approach was used. By exploring the effect of using a ranging device in powered mobility training, the staff at MHS will learn to what extent the device was beneficial to the users in improving their everyday mobility skills. Each of the three case studies conducted begins with a pre-training evaluation of the subject's current mobility skills, followed by a period of training with the ranging/sensing device, and is concluded with a post-training evaluation to measure improvement. In addition, by post testing the subjects both with and without the ranging device, one can observe if there occurred an internalization of any benefits such that the subject's mobility skills improve upon removal of the device. If this study shows beneficial results, the MHS therapists may then be able to recommend such a device, appropriate for this application, to aid in powered mobility training at their facility.

Chapter 2

Background

Several areas need to be discussed in order to better understand the issues surrounding pediatric powered mobility and the use of ranging devices with powered wheelchairs. These include: the value of powered mobility, current powered mobility training at MHS, existing wheelchair mobility training protocols, ‘smart’ wheelchairs: NavChair & the Smart Wheelchair Component System, as well as commercially available sensing devices.

The Value of Powered Mobility

Before examining the methods used in powered mobility training, it is essential to understand the effects that powered mobility has on children with disabilities. The actual benefits of pediatric powered mobility are undeniable and have been documented in several studies. According to Tefft et al’s “Pediatric Powered Mobility: Influential Cognitive Skills,” these advantages include improvements in psychosocial and developmental skills as well as increases in general activity level. In this article, the authors discuss a study performed by Paulsson & Christofferson in 1984, which found that children who use powered mobility devices “became less dependent on controlling their environment through verbal commands, more interested in all mobility skills (including ambulation), more interactive with peers, and more responsible for daily chores” (Tefft et al, 1997). Another study discussed in this article, conducted by Butler

in 1986, reported that the children exhibited increased interaction with objects and a general improvement in communication skills.

Current Powered Mobility Training at Massachusetts Hospital School

The current style of powered mobility training at MHS is generally unstructured and relies on the individual therapist's common sense and intuition to be carried out properly (Appendix A). In speaking with Gary Rabideau, the Director of Rehabilitation Engineering at MHS, he describes the powered mobility training at MHS as "free exploration"; being very objective-oriented, but not using a formal checklist of goals. For example, an occupational or physical therapist would walk alongside or behind a new powered wheelchair user while he or she is navigating through the MHS campus. The therapist may use verbal cues to help guide the driver to maintain a direct path and avoid veering into walls or sweeping the corner walls during turns. The powered mobility trainers also aid in specific tasks such as driving up or down an inclined plane and maneuvering over small curbs. Aside from using verbal cues, the therapists may also use a person or a landmark as a target for the driver to aim towards. Physical cues, such as redirecting or stopping the wheelchair are typically used as last resorts to avoid creating an unsafe situation for either the driver or people in the surrounding environment. Although this approach has been successful in training many powered wheelchair users residing at MHS in the past, the staff members responsible for mobility training are curious to learn about the techniques used by other organizations for training mobility skills. The therapists at MHS also want to gain a greater ability to quantify the progress

and impact of powered mobility training. Several training methods were researched and are discussed here.

Existing Wheelchair Mobility Training Protocols as Described in Published Literature

In the “Clinical Assessment and Training Strategies for the Child’s Mastery of Independent Powered Mobility” Karen Kangas writes about the significant difference between teaching a child mobility as opposed to driving (Kangas, 1997). She explains that these two concepts are often mistaken to be the same goal, yet should be looked at as two separate entities. Mobility entails controlled ambulation, which can be expressed in forms such as running, jumping or even sitting. When an able-bodied person learns to drive a car (typically at about age 16) they have already amassed a great knowledge and skill of mobility. Yet a child learning to use a powered wheelchair has exceedingly limited experience with mobility, and therefore must process this new information while they learn driving skills that will help them get around more efficiently. In regards to this learning curve, Kangas suggests that mobility training be conducted in short sessions for new powered wheelchair users, and that duration of the sessions and complexity of driving tasks should increase with time.

Another idea that is crucial to Kangas’ philosophy on pediatric powered mobility is that the child’s desire to be mobile is of utmost importance (Kangas, 1997). The author claims that mobility, and the desire to be mobile, is “an inherent characteristic of being human” pg 34. Kangas suggests that it then becomes the therapist’s responsibility to

encourage the child to express his or her desire to be mobile, and to allow the child to choose how to begin a training session or what they want to accomplish that day. In this way the child remains motivated and excited about learning mobility in order to become more independent.

In another article called, “Early Power Mobility: Evaluation and Training Guidelines” the author, Miranda Janeschild, describes three stages through which powered mobility should be taught to a child (Janeschild, 1997). These include:

Stage I: Exploratory

Stage II: Directive

Stage III: Purposeful

The Exploratory stage is much like the mobility training described by Kangas and involves using an activity or target to motivate the child to continue with the exercise. Janeschild also touches upon the fact that as the child learns mobility, through each novel experience in the powered wheelchair, his or her knowledge of visual, spatial and depth perception will grow. With this will also come the understanding of the child’s impact on his or her immediate environment and the ability to control this movement to reach a desired outcome. In order to avoid confusion during this initial stage of training, Janeschild suggests that verbal feedback given by the trainer is kept to a minimum (Janeschild, 1997). By doing this, the child is forced to discover solutions to direct the wheelchair in the desired manner independent of outside assistance.

In the second stage of Janeschild's training guidelines, the Directive stage, the exploration of Stage I is continued, but the skills of the child are developed such that he or she requires less time to determine how to use the powered device, and basic driving skills (like turning and driving in a straight line) have improved (Janeschild, 1997). Verbal commands, which correspond to primary skills learned in the first stage of training, are now integrated into the child's training sessions.

The Purposeful stage (Stage III), as its name implies, is meant to carry the skills learned in a controlled environment to a "normal contained environment" such as home or school (Janeschild, 1997). In this stage the child learns how to manage the specific constraints found in the environments in which they perform their every day activities.

In her article, Janeschild also includes examples of data collection sheets, which could be used during powered mobility training by following her three-stage process. Although most of the sheets are far too involved to be used in the study being conducted here, the sheet entitled, "Early Power Mobility: Evaluation and Training for the Severely Involved Client" did serve as an excellent guide for the Student Information sheet used in this study to collect general background information about the student participants (Appendix F).

Another interesting mobility training protocol was reported in MacPhee et al "Wheelchair Skills Training Program: A Randomized Clinical Trial of Wheelchair Users Undergoing Initial Rehabilitation." The authors claim that the purpose of their study was to "develop

and evaluate a safe, practical, and effective wheelchair skills training protocol that incorporated some commonly used motor-learning principles into a rehabilitation setting” (MacPhee et al, 2004). Although this recently published study takes into account similar goals as the study being conducted here, the wheelchair skills training discussed in the MacPhee et al article refers to use of manual wheelchairs, rather than powered mobility devices. Despite this difference, the manual wheelchair training protocol still provides useful information regarding the organization of the training protocol and the skills which need to be developed to become independently mobile. Similar to supporters of powered mobility training, the authors of this article claim that training independent manual wheelchair skills will result in improvements in independence, freedom of movement and quality of life (MacPhee et al, 2004).

The design of MacPhee et al’s Wheelchair Skills Training Program (WSTP) involved a control group and a trained group (referred to as the WSTP group), each containing mixed diagnostic groups including persons with neurological and musculoskeletal disorders. The control group was given the conventional training offered at the rehabilitation center at which the study was conducted, which consisted on average of about 15 hours of training, over a 5-week period. Approximately 9 of those 15 hours were used to teach transferring techniques, or methods of moving into or out of the manual wheelchair to another location, such as a bed or a stationary chair. The WSTP group was given training according to the protocol that the authors developed. This entailed learning wheelchair skills in a series of four levels. Level 1: Basic Skills, included adjusting the footrests and armrests, using the brakes, as well as propelling the

chair forward and backward. Level 2: Wheelchair maneuvering and daily living skills consisted of turns, parallel parking, reaching for objects, transferring and folding and opening the wheelchair. Level 3: Obstacle-negotiating skills involved maneuvering through doorways, driving on an incline, and ascending and descending low curbs. Level 4: Advanced wheelchair skills challenged the driver to do wheelies both in place and while moving, as well as to ascend and descend high curbs. Unlike the conventional training being provided to the control group, the WSTP group was taught through structured training sessions which began with Level 1 skills and advanced as the user learned each skill (MacPhee et al, 2004). The diagram in Figure 1 is a flow chart created to summarize the article's narrative describing how the WSTP training sessions were conducted:

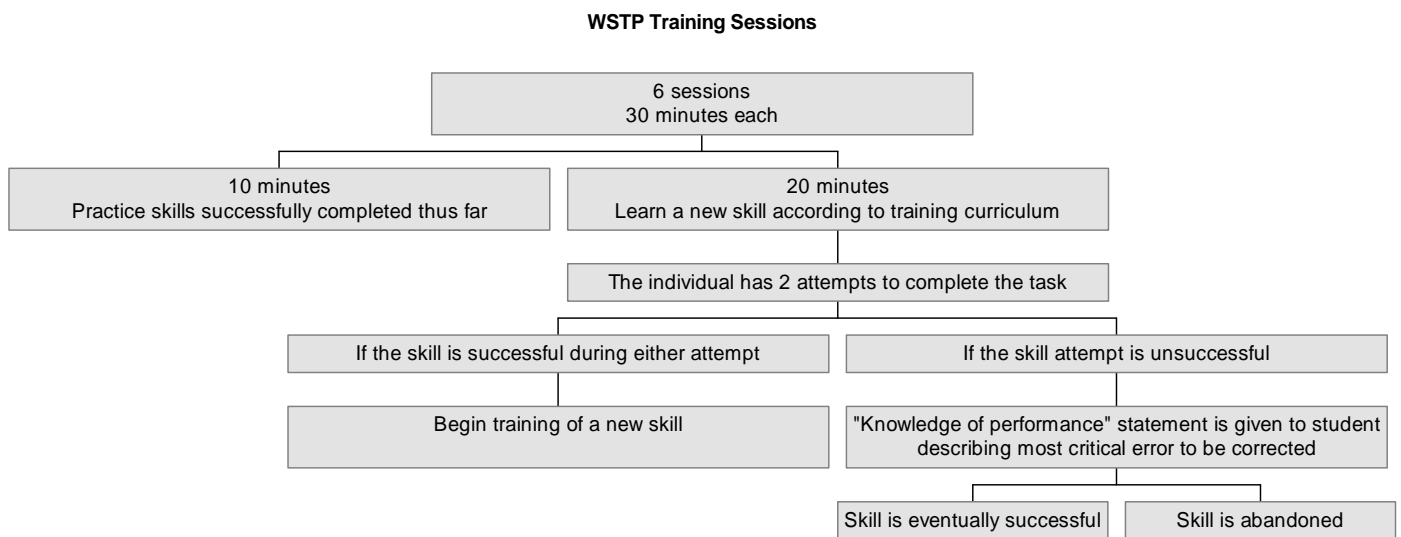

Figure 1: WSTP Training Session Diagram

As shown in Figure 1, the WSTP group is given 10 minutes to review the skills they have already mastered, and then trained for 20 minutes in performing a new skill. After that half hour, the wheelchair user is allowed 2 attempts to perform the new skill successfully. If they are successful, the trainer moves onto the next appropriate skill; if the attempt is unsuccessful then a “knowledge of performance” statement is given to the wheelchair user describing the most critical error that needs to be corrected (MacPhee et al, 2004). The skill is either eventually successful, or abandoned based on the recommendation of the trainer.

Both the control and WSTP groups were then evaluated and given scores based on the number of skills that they had performed successfully. Scores were presented in the form of percentages based on the following equation:

$$\frac{\text{Total \# of skills passed}}{\text{Total possible score} - \text{number of skills not applicable}} * 100$$

The skills that were not applicable referred to those that involved wheelchair parts that were missing from some wheelchairs (for example, footrests). The resulting scores for each group are shown in chart form in Figure 2.

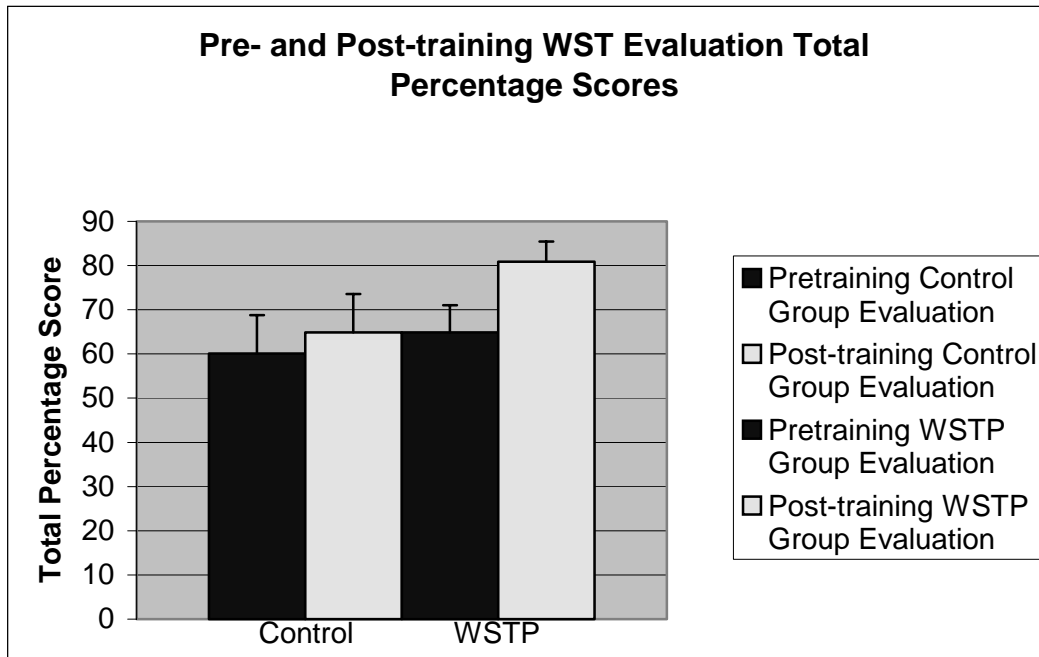

Figure 2: Wheelchair Skills Training Evaluation Scores for Control and WSTP Groups (after MacPhee et al, 2004)

The control group improved 8% during their training process, relative to their pre-training score of 60.1% +/- 14.4% and their post-training score of 64.9% +/- 13.3%. The WSTP group had a pre-training score of 64.9% +/- 9.4%, and a post-training score of 80.9% +/- 5.6%, giving the experimental group a 25% increase relative to these scores. MacPhee et al claim that statistically the WSTP group's improvement was "significantly greater than the control group's, as indicated by the interaction of evaluation and group" (MacPhee et al, 2004). When comparing the time taken to train each group, the WSTP group was trained on average for only 2 hours longer than the control group. Based on the percent improvement of each group, the authors concluded that the formalized period of training "is safe and results in significantly greater improvements in wheelchair skills than a rehabilitation program that does not include such training" (MacPhee et al, 2004).

'Smart' Wheelchairs

While researching pre-existing systems using sensing devices on wheelchairs, two powered wheelchair control systems were of particular interest. The first, the NavChair control system uses ultrasonic transducers, a computer and other necessary interface circuits to “increase the mobility of severely handicapped individuals by providing navigation assistance for a power wheelchair” (Simpson et al, 1991). The system functions by simultaneously processing the control commands given by the user as well as the feedback provided by the ultrasonic sensors to determine the final control signals to be sent to the power module. If the user gives a control command which will put him/herself in danger of colliding with an obstacle or the wall, then the final signal sent to the power module will cause an alteration in steering direction and/or a reduction of forward speed. The researchers involved with the NavChair Control System have displayed success in using a “shared control” method to allow a human and machine to interactively control a task (Simpson et al, 1991). Although the technology being applied in the NavChair research can be considered in relation to the study being reported here, the philosophy through which the technology is applied for the NavChair system is contrary to the objective of the staff at MHS. While the NavChair researchers look to supplement the user’s abilities with the computerized system, the staff at MHS want to use similar technology as a means through which to train the user to be more independent.

The second powered wheelchair control system that was of interest here was the Smart Wheelchair Component System (SWCS). Much like the NavChair system, the SWCS was designed using technologies originally developed for use in autonomous mobile robots. The authors of “The Smart Wheelchair Component System” refer to any standard powered wheelchair which has been modified with a computer and collection of sensors as a ‘smart wheelchair’ (Simpson et al, 2004). The SWCS itself consists of the sensors and processing portion of the smart wheelchair, and is capable of being added onto a variety of commercial power wheelchairs with minimal modification. The types of sensors used in the system include sonar, infrared and bump sensors which provide redundancy within the system and balance each other’s different strengths and weaknesses. When using the SWCS on a powered wheelchair, the user’s original joystick signal is sent to a laptop computer with navigation assistance software. The software then uses the input signals from the sensors to check that the user’s joystick signal will not result in a collision or other unsafe maneuver. The software processor then sends a revised joystick signal to the wheelchair controller to determine the final movement of the wheelchair. If the original user’s joystick signal and the sensors indication are in conflict, the wheelchair response can vary from limiting wheelchair speed to preventing movement or turning away from an obstacle, as seen in example cases in Table 2 of the article (Simpson et al, 2004). The SWCS is also comparable to the NavChair system in that its purpose is to “reduce the physical, perceptual, and cognitive skills necessary to operate a power wheelchair” (Simpson et al, 2004). Again this demonstrates the important difference between designing a system upon which a user

becomes dependent, rather than a learning tool through which the user can develop skills to become more independent.

Commercially Available Sensing Devices

The smart wheelchair systems remove responsibility and therefore independence, from the wheelchair driver. Since the objective at MHS is to use a sensing device as a tool for training independent powered mobility it was found that a less complex system would be better for the purpose of this project. As a result, obstacle sensing systems which provide auditory feedback were of particular interest. In order to maintain the focus of the project on the mobility training protocol itself, the use of a commercially available device was considered to be ideal. It is expected that even if this device is not specifically designed for this particular application, it will demonstrate whether or not the use of such a system is beneficial to a powered wheelchair user.

Obstacle sensing systems that provide auditory feedback when activated are readily available for applications such as reverse sensing in automobiles. They are typically marketed as tools for aiding in backing up in parking lots, or during parallel parking, and only function while the car is in reverse. When the sensors (usually radar, ultrasonic or Doppler) detect an object behind the vehicle, the system activates and a beeping sound warns the driver to stop before colliding with the object. Some of the reverse sensing systems that were researched are listed in Table 1:

Sensor Type	Company Name	Sensor Name
Ultrasonic	Shoreline Associates, Inc	Ultrasonic Reverse Sensing System with Hidden Sensors and LED
	American Road Products	ReverseGUARD
Radar	Delphi	Forewarn® Dual Beam Radar Back-up Aid
	Echomaster™	EM-PV Reverse Sensing System
Doppler	Sense Technologies, Inc	Guardian Alert®
Microwave Motion	Rostra Precision Controls Inc	Rostra Obstacle Sensing System

Table 1: Commercially available reverse-sensing systems

The reverse sensing systems in Table 1 rely on several types of sensors for obstacle detection, and each sensor type offers a different level of performance depending on environmental conditions. The Sense Technologies, Inc website summarized the key issues for most types of reverse sensing systems in a chart (Table 2).

	Cross view mirrors	Camera & monitor	Ultrasonic	Presence radar	Doppler radar
Light levels	Problem	Problem	OK	OK	OK
Dirt / mud	Problem	Problem	Problem	OK	OK
Precipitation	Problem	Problem	OK	OK	OK
Condensation	Problem	Problem	OK	OK	OK
Active / passive	Passive	Passive	Active	Active	Active
Bump / knock	Problem	Problem	Problem	OK	OK
Coverage to pavement	YES	YES	NO	NO	YES

Table 2: Key Issues for Reverse Sensing Systems (www.sensetech.com/guardianalert.htm, 2004)

The sensor types in Table 2, the Presence (Infrared) and Doppler radars are clearly the best choices for reverse sensing systems in automobiles, since it is nearly impossible to ensure that no dirt/mud will come in contact with the sensor's surface or that the driving surface will be free of bumps. Yet the microwave motion sensor, listed as the sensor in the Rostra Obstacle Sensing System, is not described or compared in the chart developed by Sense Technologies. A description of this sensor was included on the Rostra Precisions Controls, Inc website claiming that the microwave sensors do not need to be cleaned and that they "can see through snow, mud, ice even a plastic bumper" (www.rostra.com/rostra-obstacle.htm, 2004).

Each of these companies was contacted for further information regarding their reverse sensing system. Several companies responded via email, though only one offered to supply a working prototype of their system for use in this study. Rostra Precision Controls, Inc donated two different versions of their Rostra Obstacle Sensing System (ROSS) to be used toward this research. Specifications describing ROSS' performance are discussed in its operating manual, included in Appendix E. The contribution of this device allowed for the initial development of the mobility training tool to begin.

The literature review conducted helped to identify each of the issues that significantly effect pediatric powered mobility. A powered mobility training protocol could then be developed in order to meet the needs of the staff at MHS. The main goals, which became apparent through the literature search, included the need to train mobility rather than

driving, and also to examine a technique which would increase a child's independence through mobility.

Chapter 3

Methodology

The overall goal of this pilot study is to investigate a technique through which a ranging device could be used in powered mobility training to provide an auditory feedback to the subject when an obstacle within its range is detected. Prior to developing a protocol for powered mobility training, the subjects involved in the study and the obstacle-sensing (ranging) device to be used must first be identified.

Study Participants and Qualifying Criteria

There were two main qualifying criteria for subjects who participated in this study.

These criteria were formed by the recommendations of Gary Rabideau, the MHS Director of Rehabilitation Engineering, and Geoffrey Reinhold, the Occupational Therapist most involved with the design of the study. The first criterion was that subjects had to own their own power wheelchair and must have been deemed able to drive it without any physical assistance. Some level of supervision needed to maintain safety and direction was considered acceptable. The second qualifying criterion stated that subjects must have some documented history of power mobility challenges, foremost due to cognitive or perceptual impairments such as delayed initiation, distractibility or diminished cognitive vigilance (Appendix C). This second criteria limited the possible subjects from the broader student population at MHS whose primary diagnosis is being physically disabled. Those students with neuromotor disabilities which cause cognitive or perceptual impairments are a smaller sub-group of the whole MHS student population.

The subjects considered to be optimal for this study were those who were generally responsive to verbal cuing for redirection and who have shown the capability of integrating new learning.

Three students from MHS were identified to be qualified candidates for participation in the study:

Subject 1, was a young girl of age 13, with a diagnosis of Cerebral Palsy. The indications of this diagnosis for subject 1 include perceptual difficulties in vision and motor skills, as well as both visual and auditory distractibility. Subject 1 also displayed an impaired response time to stimuli, making her an interesting subject for this study involving auditory cuing.

Subject 2 was a male young adult of age 18, also with a diagnosis of Cerebral Palsy. His power mobility challenges are self-admittedly in relation to driving forward into objects or persons in front of him. Subject 2 would also become distracted by other people in his path of travel causing him to look away from the direction in which he was moving.

Subject 3 was another young girl of age 13, with a diagnosis of Cerebral Palsy. Her motor performance is considered to be athetoid, or unsteady and lacking muscular control, which causes difficulty in planned movement. Her distractibility was significantly greater than the other two subjects involved in the study and she requires

close supervision during driving. Subject 3's power wheelchair was also limited to a slower range of speeds due to her diminished cognitive vigilance.

A parental consent form was distributed to and signed by each of the participant's parent/guardian prior to their participation in the study. This form (found in Appendix B) provided the parent or guardian with a description of the study's procedure, the risks and potential benefits involved, as well as confidentiality information and the conditions of participation. A Student Information Form describing each subject's diagnosis and wheelchair setup is included in Appendix F.

Also proper measures were taken to gain approval for this study from the MHS Committee on Human Studies. A summary of the purpose and methods of the study was written by Gary Rabideau, the Director of Rehabilitation Engineering, and submitted to the committee for review (Appendix A). The study was then approved by the MHS Committee on Human Studies after careful review and discussion.

Selected Sensing Device: Rostra Obstacle Sensing System

The sensing device chosen for use in this study was the Rostra Obstacle Sensing System (ROSS), which is a commercially available device that is marketed as a reverse sensing system to be used in automobiles. The ROSS device was selected for its ability to perform under various weather conditions and also for its sophisticated auditory alert system. Other obstacle sensing systems that had comparable capabilities used ultrasonic

or radar sensors but were not feasible alternatives due to their high costs. The ROSS device used in this study was acquired via a donation made by Rostra Precision Controls Inc.

Jerry Potter, Director of Engineering at Rostra Precision Controls Inc, was helpful in providing detailed information about the ROSS device that could not be found in the operating manual. The ROSS device functions with technology known as duplex Doppler, which is a microwave sensor that activates only when there is relative motion between its affixed location and the obstacle in its path. During correspondence Mr. Potter did forewarn that generally microwave types of devices do not have the resolution or accuracy of ultrasonic devices. The detection zones in which the ROSS device activates are the Alert Zone at approximately 12 ft, the Hazard Zone at 8 ft, and the Danger Zone at 2-3 ft. The angles in which the device is activated are about +/- 45° horizontally and +/- 30° vertically. The standard setup of the device on an automobile and a visual representation of the sensor's detection zones are shown in Figure 3.

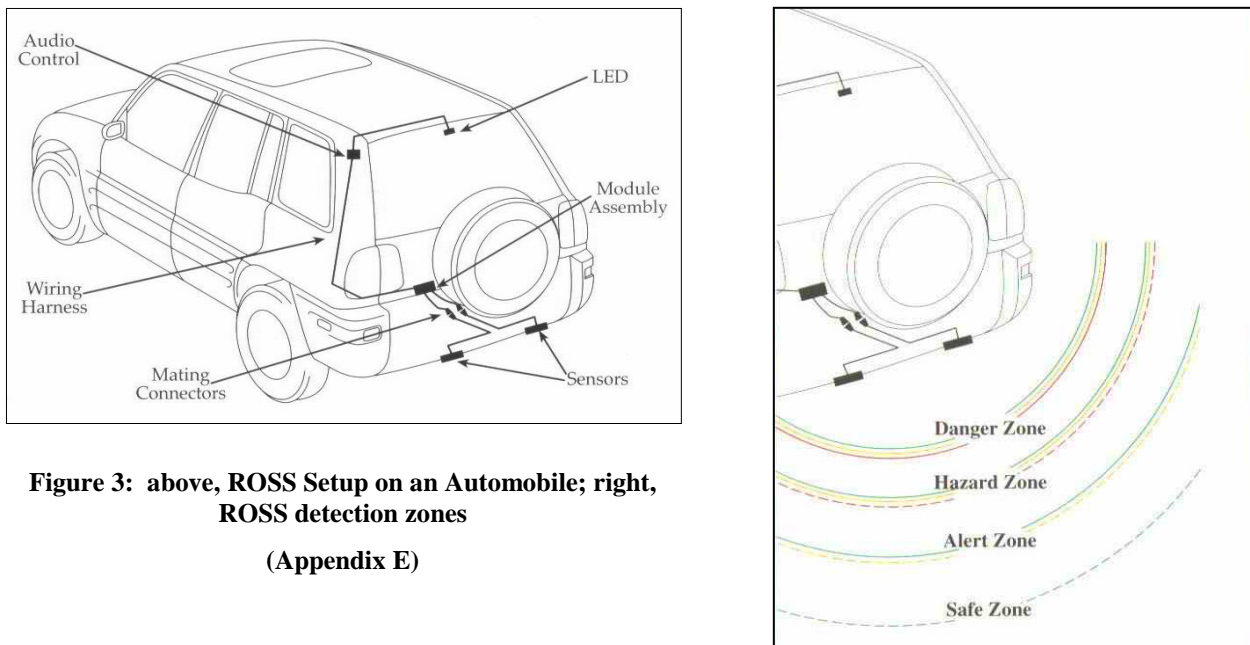

Figure 3: above, ROSS Setup on an Automobile; right, ROSS detection zones
(Appendix E)

Activations of the ROSS device within each detection zone have a corresponding auditory alert. As the obstacle detected passes from the outer Alert Zone to the inner Danger Zone the frequency of beeping increases. The LED, which acts as a visual tool for the automobile driver, also lights up according to the zone in which the obstacle is detected. The detection zones and their corresponding auditory alerts and LED indications are summarized in Table 3.

Detection Zone Alerts				
Detection Zone	LED Indication			Audio Alert
	Green Light	Yellow Light	Red Light	
Safe zone	Flashing	None	None	None
Alert zone	Solid	Flashing	None	Slow beeping
Hazard Zone	Solid	Solid	Flashing	Fast beeping
Danger Zone	Solid	Solid	Solid	Continuous tone

Table 3: Detection Zone Alerts (Appendix E)

Sensing Device Modifications for Use in Powered Mobility Training

In order to use the ROSS device for powered mobility training within the MHS campus, the device had to be modified for use on a power wheelchair. The first method used for controlling the sensitivity of the device was to limit the horizontal angular range of the

device so that the wheelchair user could drive on the paved outdoor walkways that are lined with metal railings on either side (Figure 4). The width of the walkway ranges from approximately 6.5 to 8 feet. The majority of the paved walkway is covered by a wooden roof and is therefore referred to as a pergola by some of the MHS staff.



Figure 4: Outdoor walkway (pergola) at MHS lined with metal railings

The horizontal angular range of the device was reduced by using only one sensor, rather than two sensors placed about 2 feet from one another, as seen on the car bumper in Figure 4a. The installation instructions provided on Rostra's website (www.rostra.com/rostra-obstacle.htm, 2004) indicate that the proper location for each sensor is at 1/3 increments on the bumper. By centering a single sensor and mounting it to a wheelchair, preliminary testing showed that the wheelchair could travel parallel to the metal railings without activating the device, except when the railings were approached very closely (within about 6-8 inches). When approaching the railings at angles roughly between 20-45° the device typically activated when it was within a foot of the object. When traveling perpendicular to the railings, heading directly toward them, the device characteristically activated between 3 to 4 feet from the railing, and the

auditory tone switched from intermittent beeps to a solid tone within the last 2 feet from the railing. This detection range was considered to be functional for powered mobility through the walkways of the MHS campus since it would allow for movement within the walkway, but not for an actual collision with the railings.

The second modification made to the sensing system was using a metal shield to restrict the sensor's detection capabilities. Two types of metal shields were formed: one to cover the lower half of the sensor during use, and the other to shield the perimeter in an attempt to further reduce the horizontal angular range. Each shield was formed from aluminum flat bar and attached to the sensor by Velcro so that it could be easily removed. Figure 5 shows the sensor with and without the shields.



Figure 5: ROSS unshielded sensor (left), ROSS sensor with metal shield across bottom half (center), ROSS sensor with metal perimeter shield (right)

The metal perimeter shield covered a ½ inch of the sensor's width on each edge of the sensor. This shield was used during the case study conducted with Subject 1, because initial use of the unshielded sensor was resulting in large numbers of false activations. The metal shield covering the bottom half of the sensor was only implemented for the case study involving Subject 2, in an attempt to avoid any false activations due to movement of the subject's legs relative to the sensor or detection of the ground when

traveling on upward inclines. The case study with Subject 3 was conducted only with the unshielded sensor.

Once the ROSS device was modified for this study's needs, a method for mounting the device onto the wheelchair was then developed. The sensor and its module assembly (consisting of its processing components) were first mounted onto a piece of ABS plastic with the use of Velcro. The power wires for the sensor were attached to connectors so that they could be plugged into a power source extending from the wheelchair's battery. Figure 6 is a photograph of the portable sensing device, shown upside down from its functional orientation.

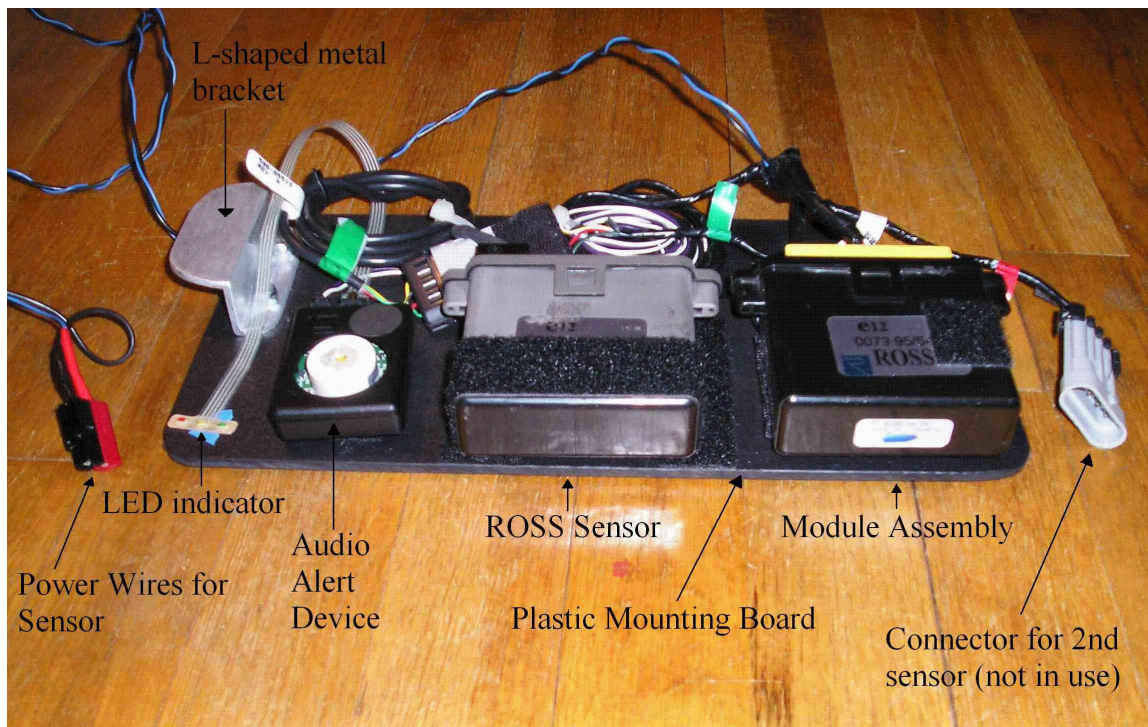

Figure 6: Portable sensing device, shown upside down

Three strips of Velcro were glued to the top of the mounting board for easy attachment to the bottom of each subjects' lap tray. Conversely, this also makes the entire sensing

device easy to remove. The lap tray is then secured onto the subject's wheelchair by sliding it onto the armrests and pushing it toward the wheelchair until its inner rim just reaches the driver. Figure 7 is a photograph of the device mounted onto a lap tray in its functional orientation; here the sensor is shown with the metal shield covering the lower half. The L-shaped metal bracket that is attached to the plastic board was used as a handle for attaching and detaching the portable sensing device to and from the lap tray.

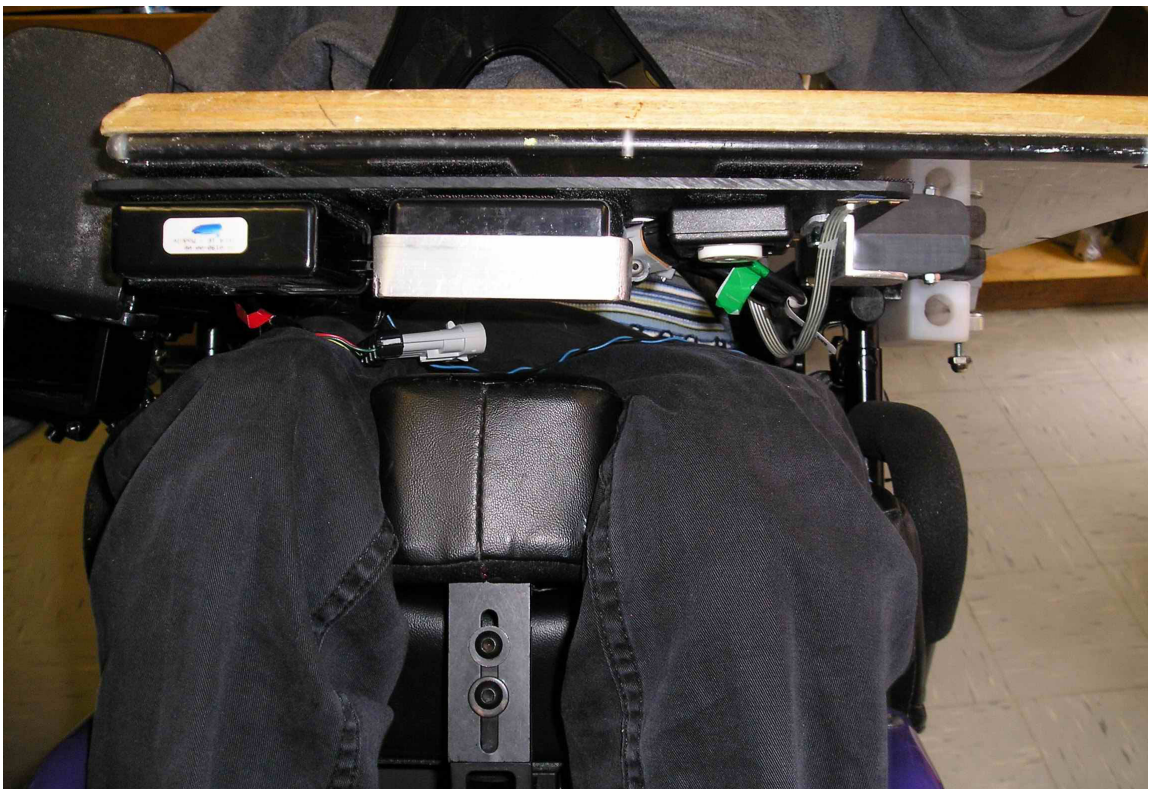

Figure 7: Functional orientation of sensing device mounted under a lap tray.

Mounting the sensing device under the lap tray isolates the device from the wheelchair driver so that they cannot see the LED flash or light up, but can still hear the auditory alert clearly. The LED was intentionally concealed in an effort to reduce the overall sensory stimulation and isolate feedback to an auditory cue. The height of the sensor is in the range of 27 to 29 inches above the ground, which is well above the 14 inches

recommended for the ROSS device when it is mounted onto a car bumper (Appendix E). Placing the sensor at this height ensures that the device will not detect movement between itself and the ground, which would cause false activations.

Development of the Powered Mobility Training Protocol

Determination of Evaluation Paths

Once the sensing device setup had been determined, development of the powered mobility training protocol could then begin. The training protocol was designed to specifically address some of the issues brought to light in the Background chapter of this report. First in order to evaluate the subjects at an appropriate mobility skill level, four basic skills were chosen to be integrated into the training protocol. These skills were: driving forward parallel to a wall (or railing), a 90° turn to the right, a 90° turn to the left, and approaching an obstacle and stopping prior to reaching it. A walkway through the MHS campus was then identified for use as an evaluation path, which would combine all of the basic maneuvering skills of interest. This path stretches from Bradford, a patient care unit, to the Elementary School on campus (Figure 8).

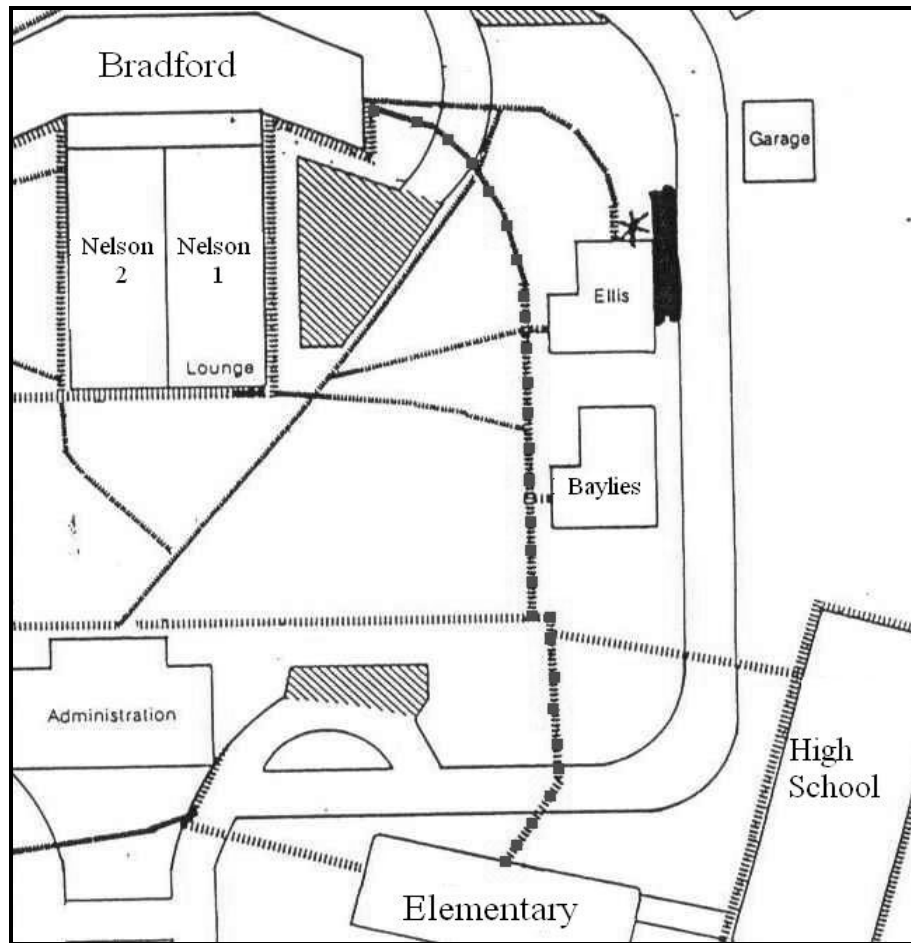

Figure 8: Pre and Post-training Evaluation Path, from Bradford to the Elementary School

The entire pathway is lined with metal railings on either side and incorporates both 90° turns as the subject passes under the clock tower, which was used as a landmark for a midpoint of the evaluation path. The approach and stop mobility skill was included in the path as the subject comes to the end of the path and must pass through an automated handicap swinging door and stop once inside the Elementary School. This particular evaluation path, from Bradford to the Elementary School, was intended to be used as a control for the pre-training and post-training evaluations. The walkways that the subjects used for their training sessions began at their dorms (Nelson 2 and Baylies) and ended at

the high school, these paths are highlighted in Figure 9. The ‘x’ markings show the path for Subjects 1 & 3, and the ‘o’ markings follow the path for Subject 2. The training session paths were deliberately designed to reduce overlap with the pre- and post-training evaluation path, which resulted in a roundabout path from the Baylies dorm to the high school.

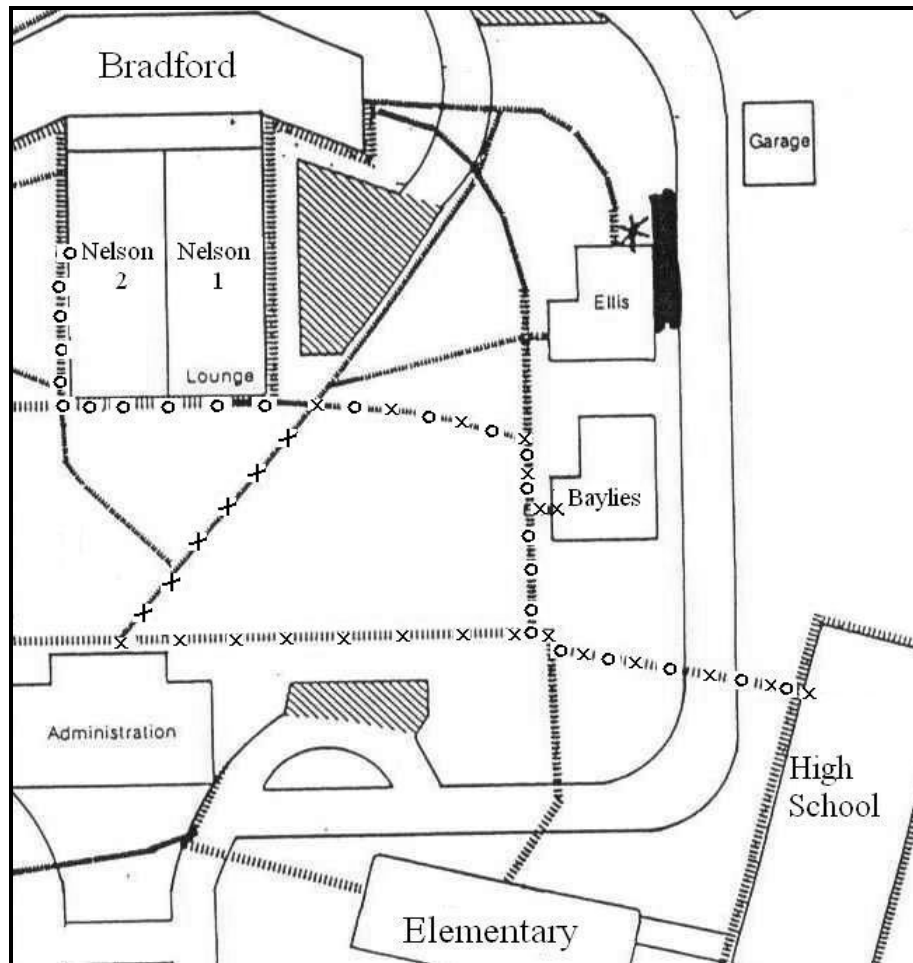

Figure 9: Training Session Evaluation Paths, from dorms to high school. The ‘x’ markings show the path for Subjects 1 & 3, and the ‘o’ markings follow the path for Subject 2.

Outside walkways were chosen for both the evaluation and training paths to reduce the number of activations due to other pedestrians and obstacles within the school’s hallways. The pre-training and post-training evaluations were conducted during class-

time to avoid additional traffic on the walkway. Since the training sessions were typically conducted during trips to and from school, it was more difficult to create a sterile environment for data collection.

Also, the issue of motivating the subject to be mobile was specifically addressed during development of the mobility training protocol. The evaluation and training paths were intentionally chosen so that each subject could complete the path, from start to finish, in a relatively short amount of time. Limiting the time that the subjects used the sensing device to 10 or 15-minute sessions made it less likely that they would become physically fatigued or frustrated with the device. During the pre-training and post-training evaluations, each subject was instructed to move toward a person that walked ahead of them in the pathway toward the school, so that they had a target to focus on while completing the task.

Stages of Powered Mobility Training and Data Collection Sheets

In order to record the progress of each subject from his or her pre-training evaluation, through training sessions, to the post-training evaluations, data collection forms were created for each stage of the study. It was originally thought that a data collection packet should be organized such that each mobility skill (approach and stop, or 90° turns) would be evaluated on its own data sheet. Each sheet would then include fields for recording: The total number of cues required to complete the task, the number of contacts made with surrounding obstacles and the number of attempts made before the skill was successful.

This data collection packet would also allow the evaluator to rank the subject's performance of each skill on a scale from 1-5 (1 = needs significant improvement, 5 = highly skilled).

The proposed data collection packet was trimmed down to a single sheet in order to make the data collection process more straightforward and easier for the evaluators to carry out. These one-page data collection sheets, labeled 'Wheelchair Skills Evaluation Forms', consisted of a map of the evaluation path and fields for recording the time required to complete the path, the number of contacts made with obstacles, the number of sensing device activations, and the evaluator's comments.

Rather than recording the total number of cues (evaluator cues and sensing device cues) required to successfully achieve a skill, only the cues provided by the sensing device should be included on the data collection sheet. Correspondingly, the evaluators were instructed to refrain from giving verbal cues during the data collection process of each stage. The variation in verbal cuing styles between evaluators therefore would not become a factor in affecting the subject's performance.

By using the evaluation paths that integrated the basic maneuvering skills of interest, the subject could then attempt each skill at least once while traveling the path. This was considered to be a natural setting in which to conduct mobility training, instead of instructing the subject to attempt the same skill, such as a right-hand turn, repeatedly until

it was successful. Repeated unsuccessful attempts could also heighten the subject's frustration toward performing a specific skill.

Finally, instead of using the evaluator's subjective ranking to characterize the subject's performance of each skill, the objective measures used were the amount of time needed to complete the task, the number of contacts made with obstacles during travel and the number of device activations. By marking the location of contacts and device activations on the map, one can gain a sense of the maneuvering skills that challenge the subject the most. The evaluator's comments also act as a narrative to explain any circumstances that were specific to that data collection session, such as pedestrians on the path or daily weather conditions.

The Wheelchair Skills Evaluation Forms used for each stage of the study can be found in Appendix G. The form used for the pre-training evaluation was marked 'Pre-evaluation without device' in the upper right-hand corner. Correspondingly, the forms used in the following stages were marked 'Training Session', 'Post-evaluation with device' and 'Post-evaluation without device'. The purpose of each stage of the study and the data collection sheet corresponding to that stage are described here:

Pre-Training Evaluation

Gary Rabideau and Geoff Reinhold acted as the evaluators for all of the pre-training and post-training evaluations. Note that Geoff was able to participate in collecting data for the pre- and post-training evaluations because none of the subjects participating in the

study were his patients. Neither Gary or Geoff were involved in the training stage of the study in order to keep them blind from the outcome of training sessions while conducting the post-training evaluations.

The function of the pre-training evaluation was to serve as a baseline measurement of the initial mobility skill level of the subject. The subject was asked by the evaluators to begin at the start of the evaluation path (exiting Bradford) and travel up the walkway until they entered the Elementary School. I acted as the motivational target by initially standing at the halfway point of the evaluation path and moving toward the end of the path as the subject approached me. Before beginning the evaluation, the evaluators explained to the subject that they would not verbally communicate with him or her until they reached the end of the path. The evaluators also followed behind the subject to avoid providing any physical cues during travel.

The data collection form for the pre-training evaluation, found in Appendix G, consists of fields to record the following: evaluator name, student name, date and time (AM or PM), wheelchair gear/drive speed, as well as the amount of time required to complete the evaluation path and the number of contacts made with objects during travel.

The wheelchair gear/drive speed is an indication of the percentage of the maximum speed capability of the wheelchair. Each of the subjects' wheelchairs had a maximum speed of 6.25 mph, and gears (or drives) ranging from 1-4, slowest to fastest. The affect of the

gear selection on the speed of the wheelchair is investigated further in the Discussion Chapter of this report.

The time was recorded at the starting point, midway point (designated by the clock tower) and the end point of the evaluation path. Any physical contact ranging from brushing against a surface to an obvious impact was considered a contact made during travel. These two metrics, time and number of contacts, were used to quantify the subject's performance in order to draw conclusions about potential improvements over the course of the study. It was extremely important to use objective measurements such as these in order to eliminate any discrepancies or bias resulting from using data gathered by several different evaluators.

A map of the evaluation path was included on the left-hand side of the page to allow the evaluator to mark directly on the map when a contact was made with the railings. The evaluation path that was selected for the pre-training evaluation, connecting Bradford to the Elementary School, was also used for both post-training evaluations for the purpose of consistency. Several blank lines designated for evaluator's comments were included just below the map.

Powered Mobility Training Sessions

The purpose of the training sessions was to allow the occupational (OT) and physical therapist (PT) team to assist the subject in learning the meaning of the auditory alert and

how to integrate that feedback in order to redirect them or keep them on task during powered mobility driving. Each therapist was provided with a memo outlining the purpose of the study and the expectations for them, as participating clinicians (Appendix C). Training sessions were structured so that the OT or PT met the subject at his or her dorm and mounted the sensing device onto the subject's chair via the lap tray. All training sessions then began with orienting the subject to the device and the manner in which it operates. The therapist was allowed to provide verbal and physical cues to show the subject how the device activates when the wheelchair approaches an object. Verbal and physical cues were restricted to only the first 1/3 of the training path, after which the subject was expected to rely on the cuing of the sensing device for the remainder of travel to the high school. The therapists, acting as evaluators, were asked to record data only for the last 2/3 of the path when they were not providing verbal or physical cues to the subject to aid in driving. Unlike the pre- and post-training evaluations, training sessions were conducted on the training path in both directions, from the dorm to the high school and vice versa. When the subject reached the endpoint of the path the sensing device was removed from the wheelchair by the therapist.

The data collection sheets used for the training sessions were very similar to those used in the pre-training evaluation (Appendix G). The main difference was that during the training sessions the number of device activations was also recorded in addition to the amount of time taken to complete the path and the number of contacts made with objects during travel. The number of sensing device activations were reported as the total number of activations, as well as the total number of solid light/sound activations. Since

the ROSS sensor activated an auditory alert that corresponded to the proximity of the object being detected, as the wheelchair got closer to the object the auditory alert increased frequency of beeping until a continuous tone was heard, and the red LED light became solid. The total number of solid light/sound activations was then defined as when the auditory alert became a continuous tone. The total number of sensing device activations included the number of solid light/sound activations as well as activations that resulted in momentary beeping.

The other characteristics specific to the training sessions' data collection sheets were that the maps were used for displaying the location of contacts and sensing device activations. The location of the first 1/3 of the path, in both directions of travel, was specifically marked to act as a reminder to the therapists to stop providing verbal and physical cues to the subject. Also, there existed a box in the upper right-hand corner of the sheet for the therapist to use to indicate which number training session was underway.

Post-Training Evaluations

The first post-training evaluation, without the sensing device, was conducted exactly as the pre-training evaluation and serves as a direct comparison between the two. This may be able to show that the subject has internalized some of the environmental cues previously provided by the sensing device. The second post-training evaluation is the same as the pre-training evaluation, but using the sensing device on the wheelchair to provide cues to the subject. The post-training evaluation with the sensing device can be compared to the pre-training evaluation to determine if the sensing device aids the subject

in avoiding contacts with objects and in achieving efficient mobility during travel. Signs of more efficient mobility could be completing the path in less time, or the evaluator noting that the subject traveled more directly rather than zigzagging or veering to either side. Yet the comparisons between pre- and post-training evaluations must consider the factor that the subjects had been specifically practicing mobility during training sessions.

The two post-training evaluations can be compared to determine the difference in improvement between when the subjects can rely on the sensing device cues and when they must be self-reliant for environmental feedback. By conducting the post-training evaluations on the same day, one can attribute any difference in performance directly to the use of the sensor, excluding the factor of practicing mobility over time.

The post-training evaluation data collection sheets (Appendix G) were identical to the training session sheets, except that the map included the path from Bradford to the high school, as in the pre-evaluation sheets. The box in the upper right-hand corner of the sheet was checked to signify whether the data corresponded to the evaluation with or without the sensing device.

Timeline of Case Study

The intended timeline for each case study was to begin with the pre-training evaluation on a Friday. Training session would begin the following Monday and would be performed over the next nine business days (to the following Thursday). It was suggested that during the training stage the therapists perform anywhere from six to ten

training sessions over the nine day period. This structure would allow for a morning and afternoon session to be completed in a given day, if necessary. Finally, the subject would have their post-training evaluations on the Friday that fell on the 10th business day (2 weeks from the initial pre-training evaluation). The intention of conducting each case study in a 2-week period was to give the subjects enough time to learn the meaning of the sensing device auditory cues and to potentially internalize this feedback to use when the device was removed. The limited time period was also a means for controlling the variables in the subject's wheelchair setup and general health, which could vary significantly over long periods of time.

Finally, informal interviews were set up with the OT/PT teams for reflection on each subject's mobility after study had concluded. Each therapy team was asked: 1) if and how their patient's participation in the study was beneficial, 2) were there visible changes in their patients behavior or attitude regarding powered mobility, 3) how the sensing device itself could be improved and 4) how the training sessions could be improved. Results from each stage of the mobility training protocol as well as the therapists' comments recorded from the short interviews are included in the following chapter.

Chapter 4

Results

Each of the subjects has two sets of data reported for the pre- and post-training evaluations reflecting the evaluations conducted by both Gary Rabideau and Geoffrey Reinhold. Either the occupational or physical therapist for each subject completed a data sheet during the training sessions, so only one set of data will be reported for the training session evaluations. The actual completed data sheets can be found in their original form in Appendix H.

Case Study Results for Subject 1:

Subject 1 was enthusiastic about participating in the study and seemed to learn the meaning of the auditory feedback given by the sensing device very quickly. Despite any perceptual difficulties, she displayed confidence in regards to her wheelchair driving capabilities during her pre-training evaluation. Subject 1 did complete her pre-training, training and post-training evaluations within the allotted two-week period intended for her case study. The training sessions and the post-training evaluations were conducted with the metal perimeter shield attached to the ROSS sensor, which limited its horizontal range. This subject's occupational therapist was Donna, and her physical therapist was Faith. The results from each stage of her powered mobility training are summarized in Table 4:

Evaluation	Evaluator	Wheelchair Gear/Drive Speed	Time at midpoint (min:sec)	Total Time (min:sec)	# of Contacts	Total # of activations	# of Solid Light/Sound Activations	Comments
Pre-training	Gary	4	1:41	2:49	0	n/a	n/a	none
	Geoff	4	1:40	2:50	0	n/a	n/a	Ranged w/in 2.5 ft of left side for Bradford -> Clock Tower. Came close to front end contact before stopping for right turn, w/in 12-16 inches.
Training Session #								
1/5	Donna	4	1:50	3:03	0	>80	1	Beeped the entire time when in the pergola despite good driving.
2/5	Donna	4	1:10	2:15	0	>60	3	Constant beeping in pergola!
3/5	Faith	4	1:26	3:15	0	27	3	Patient told to stop driving at beeping. Able to follow through 9/10 times.
4/5	Faith	4	1:10	4:29	0	24	1	Although it only beeped 25x, the duration of noise lasted throughout the time in the pergolas. It was 24x of starting & stopping.
5/5	Donna	4	2:17	4:41	0	25	2	Decreased volume of beeping - near constant beeping in pergola
Post-training								
without sensing device	Gary	4	1:41	2:46	0	n/a	n/a	Held to the middle of the path
	Geoff	4	1:42	2:47	0	n/a	n/a	2.5 - 3 ft from left rail from Bradford to Ellis. :) Clean right turn, she slowed!
with sensing device	Gary	4	2:47	3:55	0	---	---	Periodic activations throughout
	Geoff	4	---	3:55	0	---	---	Map showed periodic beeping throughout, sustained tone only when another pedestrian approached the wheelchair. Subject 1 stopped the chair and waited for the person to pass. Subject 1 also stopped frequently after sensor activation (10-15 times)

Note: --- indicates the field on the form was left blank.

Table 4: Subject 1's Wheelchair Skills Evaluation Form Results

Figure 10 compares the time needed for subject 1 to complete the pre- and post-training evaluation path.

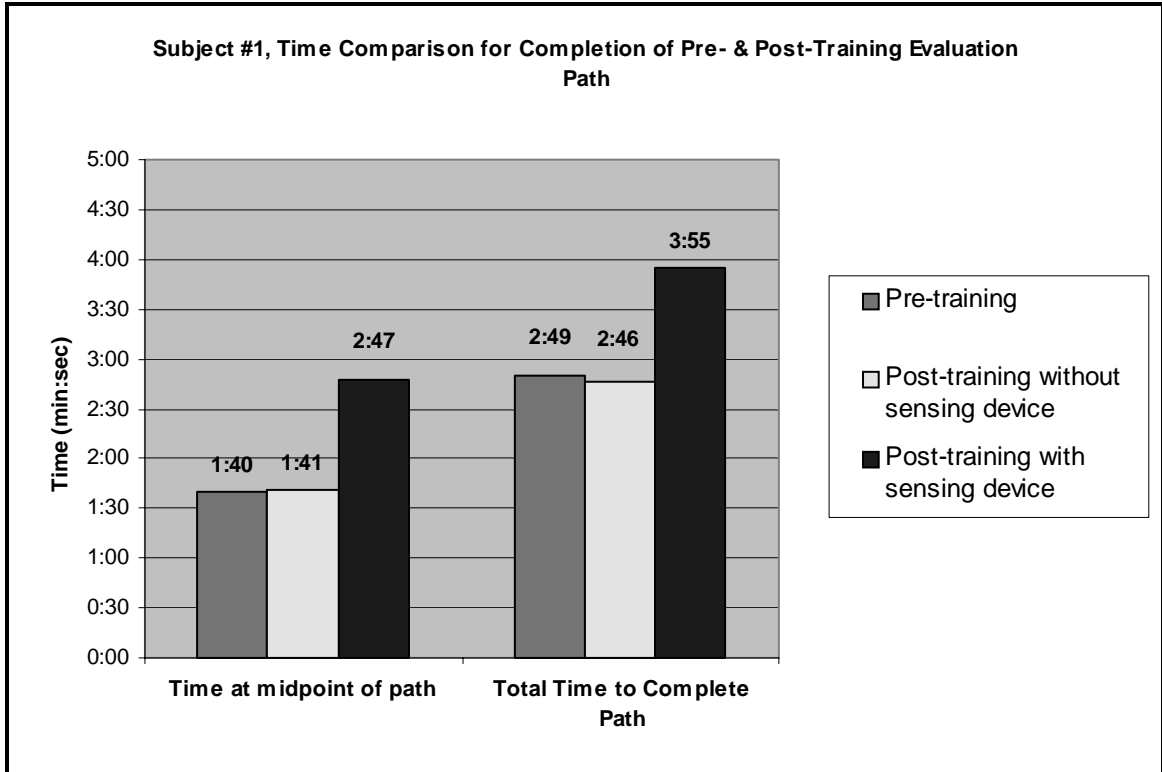

Figure 10: Subject 1, Time Comparison for Completion of Pre- & Post-Training Evaluation Path

The values reported as the time at the midpoint and the time to complete the path are averages of the measurements provided by Gary and Geoff during the pre- and post-training evaluations. This is the case for each of the time comparison figures in this chapter.

When Faith was interviewed after the completion of Subject 1’s post-training evaluation she stated that there were no visible changes in Subject 1’s behavior or attitude regarding powered mobility. When asked about how the sensing device could be improved, Faith

suggested reducing the hyperactivity. In regards to the training sessions, Faith wanted to determine a consistent time to conduct the evaluations in order to reduce the number of people passing by, or to record the number of people who passed by during the evaluation.

Case Study Results for Subject 2:

Subject 2 was also happy to offer his time to participate in the study. He seemed very self-aware of the areas of improvement in which he could become a safer driver and how an auditory feedback could help bring his attention to task. The training sessions and the post-training evaluations were conducted with the ROSS sensor and metal shield that blocked the lower half of the sensor from detecting obstacles. The case study for Subject 2 was performed over a 4-week period, since the shield modification made to the sensor was developed after the pre-training evaluation in order to begin the training sessions. This subject's occupational therapist was Bill, and his physical therapist was Michelle. The results from each stage of his powered mobility training are summarized in Table 5:

Evaluation	Evaluator	Wheelchair Gear/Drive Speed	Time at midpoint (min:sec)	Total Time (min:sec)	# of Contacts	Total # of activations	# of Solid Light/Sound Activations	Comments
Pre-training	Gary	3	1:53	3:23	---	n/a	n/a	Veering across midline in path between Bradford and Baylies. Near contact on right of bridge by Elementary School
	Geoff	3	2:05	3:24	0	n/a	n/a	Subject 2 quote "Sometimes I'm driving next to my friend and I'll accidentally bump into her. But that's me."
Training Session #								
1/3	Bill	3	7:00	11:00	0	4	*n/a	Seemed to correct direction x2 when activation occurred. I even question why other 2 activations occurred.
2/3	Bill	3	2:00	6:30	0	18	*n/a	Generally corrected at signal activation. Most occurred to the left side. Patient became very frustrated at repeat activations/inconsistency
3/3	Bill	---	5:00	7:00	0	10	*n/a	Frustration noted. Corrected most of the time. "Why is it going off?" Map shows: of 10 activations, 9 on the left, and one caused by a person passing by.
Post-training								
without sensing device	Gary	3	2:09	3:41	0	n/a	n/a	Map showed: Slight veer after Bradford. U Turn after clock tower. Near contact over bridge.
	Geoff	3	2:09	3:30	0	n/a	n/a	Some confusion at fork between H.S. and Elementary. Needed verbal reminder, delay approx. 5 seconds. Temporarily stopped to scratch nose at beginning of path.
with sensing device	Gary	3	2:46	4:24	0	15	*n/a	Veering to left at the end of the path.
	Geoff	3	2:45	4:17	0	13	*n/a	Three solid tones when subject was very close to wall (< 8 inches). Frequent activations - seemingly at highest cruising speeds. Subject 2 tended to drive on the left side for most of the trip (from 1/4 to the end).

Note: --- indicates the field on the form was left blank.

* There was no field included for recording the # of Solid Light/Sound Activations on the training session & post-training evaluation sheets.

Table 5: Subject 2's Wheelchair Skills Evaluation Form Results

When Subject 2's OT/PT team was interviewed after post-training evaluation, both therapists stated that he would learn with cuing and that the device is a good idea to focus his attention to location in space. When asked if Subject 2 had displayed visible changes in behavior or attitude regarding powered mobility, Bill stated that there were no visible changes since Subject 2 was a long-time driver with established mobility. Michelle suggested there were no visible changes in Subject 2's behavior or attitude because the sensing device was too hyperactive. Bill recommended that the sensing device be improved by making it more consistent and addressing the issue of people walking in front of the device. Michelle advised to lessen the sensing device's hyperactivity and also to use a different auditory prompt, rather than the current beeping noise. Bill stated that the training sessions could be improved by separating the activations according to which obstacle cause it, otherwise eliminating false activations completely.

Figure 11 compares the time needed for the subject 2 to complete the pre- and post-training evaluation path.

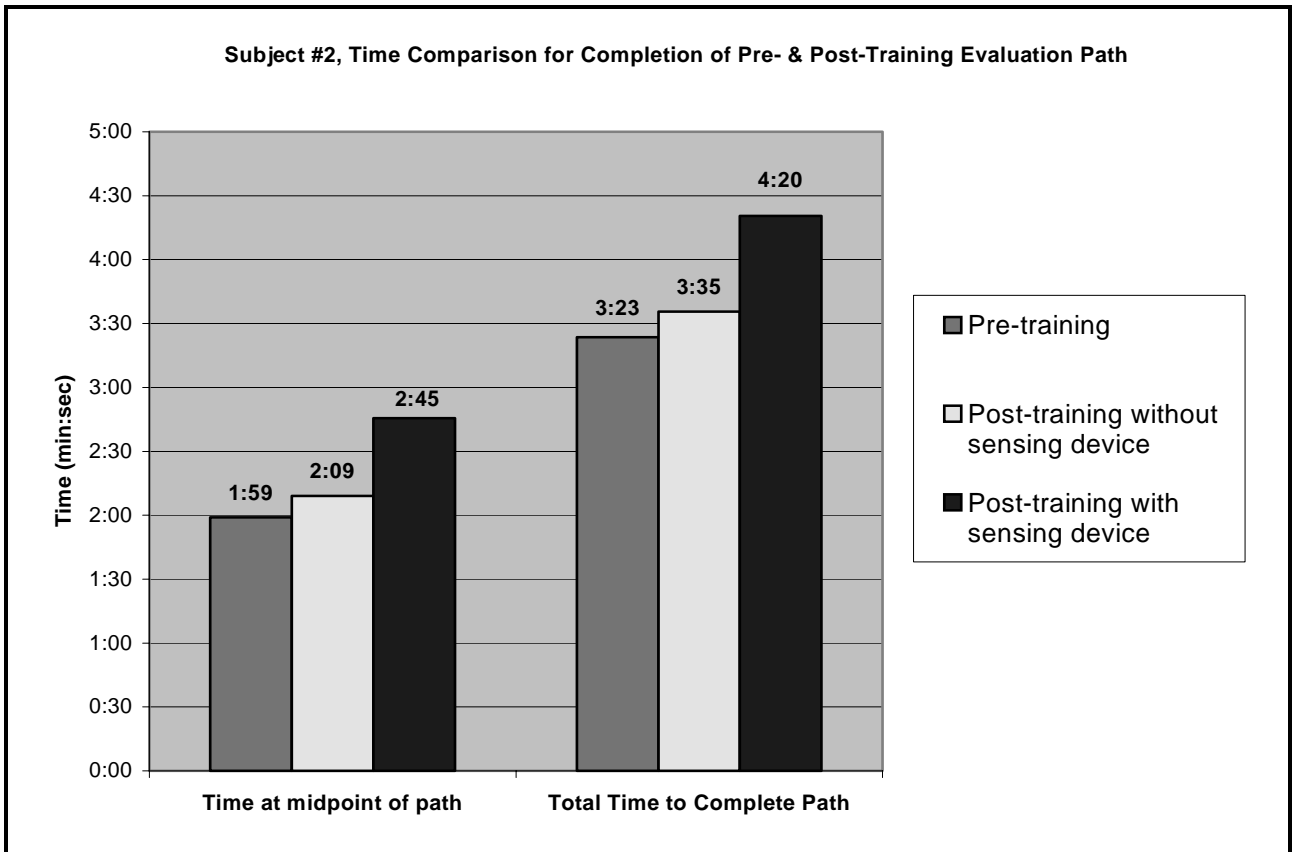

Figure 11: Subject 2, Time Comparison for Completion of Pre- & Post-Training Evaluation Path

Case Study Results for Subject 3:

Subject 3 was very cooperative and willing to participate in the study. At the time of the pre-training evaluation, she did not have a lap tray set up for use on her wheelchair, which delayed the beginning of the training sessions. During this time there were also complications with the performance of her wheelchair in that it was nonfunctional and could not be used. For these reasons, about three weeks passed between the pre-training evaluation and the first training session. The training sessions were conducted about once weekly over a 4-week period, after which the post-training evaluation was completed. Both the training sessions and the post-training evaluations were performed

with the unshielded sensor, since the subject's wheelchair was restricted to a slow drive speed on account of her diminished cognitive vigilance. Trial runs with the sensing device on Subject 3's wheelchair showed that it provided the most appropriate response when left unshielded. The subject stopped to rest and tilt her wheelchair during the pre-training and post-training (with sensing device) evaluations. This subject's occupational therapist was Donna, and her physical therapist was Faith. The results from each stage of her powered mobility training are summarized in Table 6:

Evaluation	Evaluator	Wheelchair Gear/Drive Speed	Time at midpoint (min:sec)	Total Time (min:sec)	# of Contacts	Total # of activations	# of Solid Light/Sound Activations	Comments
Pre-training	Gary	1	7:50	13:15	---	n/a	n/a	Near contact on left while veering between Bradford and Ellis. Stated she was tired at the clock tower. Close to railing on right hand turn. Stopped to rest while on bridge, stating that her hand was tired.
	Geoff	1	7:45	12:55	1	n/a	n/a	At contact touched rail, had drift to left, moving very slowly. Stopped for 40 seconds. Subject 3 quoted, "Have to rest my back", "my hand hurts", "I'm tired".
Training Session #								
1/4	Faith	---	1:56	5:45	0	8	0	Did not beep at all appropriate times.
2/4	Faith	---	---	7:00	0	5	1	None
3/4	Faith	---	3:45	5:30	0	7	1	1x sounded due to 2° athetoid movement. Several times did not sound appropriately.
4/4	Faith	---	2:07	5:55	0	14	3	At first, seemed very sensitive. Then it seemed more appropriate.

Evaluation	Evaluator	Wheelchair Gear/Drive Speed	Time at midpoint (min:sec)	Total Time (min:sec)	# of Contacts	Total # of activations	# of Solid Light/Sound Activations	Comments
Post-training								
without sensing device	Gary	1	6:18	10:42	1	n/a	n/a	Veering through entire path, self-corrected after contact.
	Geoff	1	6:13	10:33	1	n/a	n/a	Made contact, stopped, corrected & centered then continued. Though centered, frequent adjustments through the right turn, no contacts at that point.
with sensing device	Gary	1	7:10	11:45	0	2	---	Drift was smoother than "veer" of post eval without device. Movement off course and self correction was less severe. Her overall attention to task seemed greater for this post eval than other. Map showed activation at beginning of path, due to drift. Second activation at end of path when automatic door swung open. Device did not activate during veering through left and right turns.
	Geoff	1	7:09	11:33	0	1	---	More centered on path - made stops to adjust hair/gloves due to wind and cold. Tilted chair at this point for 10 secs. Seemed <u>more</u> controlled. Map showed activation at beginning of path.

Note: --- indicates the field on the form was left blank.

Table 6: Subject 3's Wheelchair Skills Evaluation Form Results

Figure 12 compares the time needed for the subject 3 to complete the pre- and post-training evaluation path.

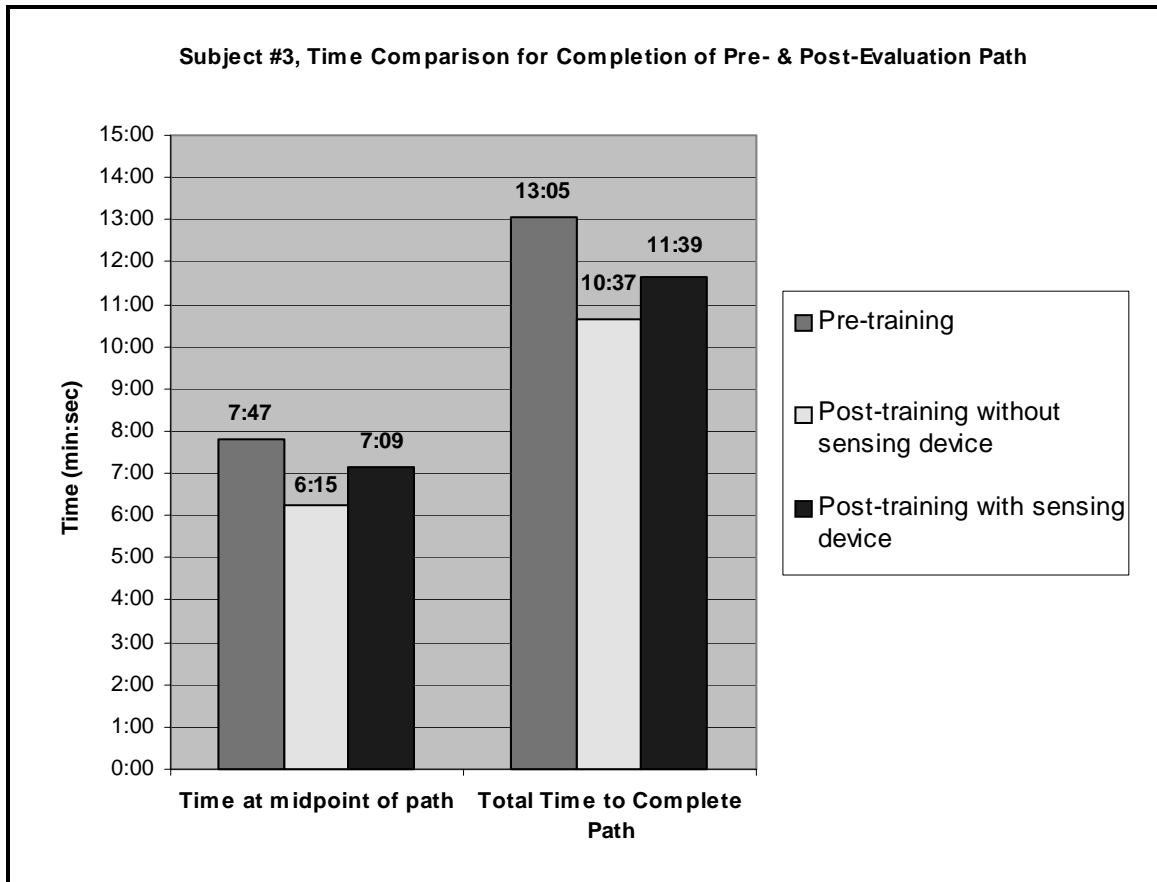

Figure 12: Subject 3, Time Comparison for Completion of Pre- & Post-Training Evaluation Path

When Faith was interviewed after the completion of Subject 3’s post-training evaluation she stated that Subject 3 did show an overall improvement in driving. Faith believed that the subject did integrate the beeping of the sensing device with its distance/ranging capabilities in obstacle detection. Donna commented that Subject 3 began driving better and was staying on the right of the path more often. When asked about visible changes in the subject’s behavior or attitude toward mobility, Faith stated that Subject 3 did not display a change since she had always been independent-minded. The OT/PT team suggested that the sensitivity of the sensing device was generally hypoactive. Yet when Subject 3 hit the lap tray due to athetoid movements in her arms, the device would activate. Faith suggested that the training sessions could be improved by marking the

halfway point on the sheets. As in the interview to discuss Subject 1's results, Faith wanted to determine a consistent time to conduct the evaluations in order to reduce the number of people passing by, or to record the number of people who passed by during the evaluation.

Discussion of Case Studies

The main factors that affected the results for each subject were: the subject's individual skill level in powered mobility, the conditions of the sensor (shielded or unshielded), and the speed at which the wheelchair was traveling. Since all participating subjects used a Ranger X Storm Series powered wheelchair, the matter of wheelchair speed will be discussed first.

The performance adjustments available on the Ranger X Storm Series (the wheelchair used by all of the subjects) are investigated in order to better understand the indication of the gear/drive level (1-4) on the wheelchair's speed of travel. According to Gary Rabideau (Director of Rehabilitation Engineering at MHS), the manufacturer's specification for maximum wheelchair speed is 6.25 mph, and can be adjusted using independent gears (or drives) ranging from 1-4. For the subjects involved in the case studies discussed here, the drives were programmed so that generally drive 1 was the slowest and drive 4 was the fastest. Yet drives were programmed on a case-by-case basis for each subject and each drive was independent of the others. Each drive level is programmed into the wheelchair by specifying percent values for each of the following

performance functions: forward speed, turning speed, acceleration, sensitivity, braking, reverse speed, torque and power level. Slower drive levels, 1 or 2, are typically programmed so that the combined performance functions allow for safe and effective indoor driving to maneuver through busy hallways and classrooms. The faster drive levels, 3 and 4, are adjusted for efficient performance in traveling across campus, and can be used only by students who are capable of driving safely at fast speeds. It is very difficult to assign a numerical value for the maximum speed of each drive level because of the many performance functions that define it. Since each subject acts as its own control for this study and comparisons between case studies will not be made, it is sufficient to state that the drive levels, 1 through 4, are indications that the maximum speed of the wheelchair was some percent of 6.25 mph, with drive 1 being the slowest and drive 4 being the fastest. Since the original application of the ROSS sensor was for reverse sensing in automobiles, speeds in the range of 0 - 6.25 mph are assumed to be reasonable reversing speeds within which the sensor could perform.

The effects of each of the remaining factors are discussed here for each subject:

Case Study Discussion for Subject 1:

Subject 1's basic maneuvering skills proved to be good during her pre-training evaluation. Yet her fast pace (Gear 4) made safe maneuvering through the clock tower more difficult causing her to come to a full stop before completing the 90° right-hand turn toward the Elementary School.

The sensing device was introduced during the first training session with the ROSS sensor partially blocked using the metal perimeter shield. This metal shield restricted the face of the sensor by a half inch on either side, as shown in Figure 5. While this may have limited the horizontal range of the sensor's detection zone, it seemed to extend the sensor's detection capabilities in the forward direction causing intermittent activations when obstacles were outside of the 4-foot detection zone that is expected when using a single sensor. The large number of intermittent activations, noted by the therapists during the training sessions, was most likely a direct result of the extension of the sensor's detection capabilities caused by the perimeter shield. The therapists' comments support this theory since the device was generally hyperactive when traveling through the 'pergola' portion of the path, which was a covered walkway lined with railings on either side. Therefore if the subject's wheelchair were directed slightly to the left or right side of the path, the sensor would activate due to the railing being detected. The low number of solid device activations was a clear indication that Subject 1 only approached the railings or other obstacles within a range of 6-8 inches a few times. The constant intermittent beeping was both confusing and frustrating for the subject and the therapy team because the sensing device feedback was not useful in redirecting the subject.

The time taken to complete the evaluation path was essentially the same between the pre-training evaluation and post-training evaluation without the sensing device. The post-training evaluation with the device took approximately 1.4 times longer to complete

because the subject's OT/PT team had instructed her to stop briefly when the device activated, so she continued to do so during the post-training evaluation (Figure 10).

The number of contacts measured was not a good metric for improvement of wheelchair skills for Subject 1 since she never made contact with the railings or other obstacles in her path during any of the stages of the study. Yet the comments from her post-training evaluation without the sensing device showed that she slowed down when taking the right-hand turn, which was an improvement from her pre-training evaluation when she had to come to a complete stop to avoid sweeping (or scraping) the railing when turning.

Overall, the metal perimeter shielding combined with a relatively fast wheelchair speed (drive 4) created a very hyperactive response from the sensing device for the case study involving Subject 1. In an attempt to minimize the number of device activations, Subject 1 did slow down when using the device, which led to safer maneuvering in turns. During the post-training evaluation without the device the subject was self-reliant in slowing down before the right-hand turn. Still, it is more likely that Subject 1's performance improved on account of her explicitly practicing mobility rather than as a result of internalizing the cues provided by the sensing device, since they occurred so often. Subject 1's powered wheelchair mobility skills were well developed for performance on the chosen pre- & post-training evaluation path, so although she met the criteria for the study, her mobility challenges could not be well addressed through the use of this particular sensing device setup. She did however seem to become more aware of her role as a driver through participation in the study. Also the self-reliance she displayed in her

post-evaluation without the device suggests that she did become somewhat more independent in driving.

Case Study Discussion for Subject 2:

Subject 2 drove in gear 3 during each stage of the study and only experienced two near contacts with the railing while traveling on the footbridge toward the Elementary School. These near contacts occurred during the pre-training evaluation and the post-training evaluation without the sensing device. In the post-training evaluation with the sensing device there were no near contacts reported, but three solid device activations occurring within 8 inches of the wall, which resulted from the same veering behavior that was observed during the pre-training evaluation. Since there were no actual contacts made with the railings or other obstacles, no assumptions can be made in regards to improvements in avoiding collisions by using the sensing device. It did seem from the evaluation comments that the subject was still veering while driving during the post-evaluations, as was noted in the pre-training evaluation.

Although Subject 2's OT, Bill, had stated that the subject was a long-time driver with established mobility, he did feel that the sensing device would help in focusing the subject's attention to his location in space. The sensing device used with Subject 2 was the ROSS sensor with metal shield blocking the lower half of the sensor, as seen in Figure 5. This sensing device setup seemed to reduce the number of intermittent activations in comparison with using the perimeter shield used for Subject 1. The total

number of device activations ranged from 4 to 18 during the training sessions.

Interestingly, the more time it took for Subject 2 to complete the training path, the less activations occurred, implying that when the subject drove more slowly and carefully he was driving better. Bill commented that most of the activations occurred to the left side and that the subject became frustrated at repeat activations. If the device was hyperactive despite the subject's performance in driving, the subject may have become frustrated and rushed through the path to complete the task. On the other hand, the subject may have provoked the sensing device activations by driving at a faster speed. During the post-training evaluation with the sensing device, Geoff noted that the frequent activations seemed to occur at the highest cruising speeds. Being that Subject 2's maximum cruising speed (in drive 3) was most likely around 4 or 5 mph it was not anticipated that the sensor would become significantly more sensitive in activating at this speed. False activations may have been avoided by restricting the subject's drive gear to 1 or 2 while conducting training and evaluations with the sensing device. Unfortunately, this was not considered at the beginning of Subject 2's case study because he was already accustomed to using drive 3 while traveling outside and it would not have been practical to conduct the study in an alternate drive.

The time taken to complete the evaluation path was barely longer for the post-training evaluation without the sensing device in comparison to the pre-training evaluation. This short delay was due to the confusion that occurred at the fork between the high school and elementary school, when the subject had to do a U-turn to get back on track. The post-training evaluation with the device took approximately 1.3 times longer to complete

than the pre-training evaluation. The increase in time needed to complete the path may have been due to the subject's attempt to minimize the number of sensing device activations, or simply from taking the time to redirect the wheelchair after each device activation (Figure 12).

In general, the sensing device feedback provided to Subject 2 proved to be ineffective in redirecting him, but useful in bringing his attention to task. The half shielded sensor and drive 3 combination resulted in intermittent beeping throughout the path leading to the subject's frustration and confusion. Due to the hyperactivity of the sensing device, Subject 2 did not show proof of internalizing cues provided by the device since when he was post-tested without it he repeatedly veered close to the railings just like in his pre-training evaluation. Subject 2's independence in driving appeared to be unaffected by the mobility training protocol.

Case Study Discussion for Subject 3:

Subject 3 required verbal motivation throughout the entire pre-training evaluation and therefore was repeatedly told to move toward the Elementary school and to follow the person, myself, acting as a target ahead of her on the path. I walked backwards on the path, facing the subject, yet did not provide any verbal cues during the evaluation. When the subject did stop to rest or when she was complaining of pain in her back and her hand, verbal responses were only given by Gary or Geoff.

Subject 3 used drive 1 for both the pre-training and post-training evaluations (the drive level was not recorded on the training session evaluation sheets). The sensing device setup used was the ROSS sensor with no shielding. This was considered to be appropriate because the wheelchair speed was relatively slow and therefore any false sensing device activations related to faster drive speeds would be eliminated.

An additional factor in Subject 3's results was that the training sessions and post-training evaluations were conducted in late November through early December, at which time the outdoor pathways at MHS are lined with wooden panels to help block the wind and make traveling outside more comfortable. Figure 13 shows the wooden panels lining only the left side of the walkway, while the right side remains with just the metal railings.



Figure 13: MHS walkways lined with wooden panels during the winter months

The addition of wooden paneling to the walkway railings was not expected to increase the sensor's sensitivity because the wooden panels are of relatively low-density in relation to the metal railings. In the operating manual of the Rostra Obstacle Sensing System the manufacturer states that low-density objects are first detected when closer to the sensor than the outermost detection zones (Appendix E). It can then be assumed that the higher density material would be detected first, so activations would occur similarly when the railing on the right or left side was detected. According to the comments made during the training sessions and post-training evaluations, the wooden panels did not cause the sensor to be more or less sensitive toward the railing with the paneling.

Subject 3 made one contact with the railings during both the pre-training evaluation and the post-training evaluation without the sensing device. During the pre-training evaluation, the subject made contact with the railing on the left side while veering to the left. The evaluators commented that she was moving very slowly. When Subject 3 contacted the railing during the post-training evaluation without the sensing device, she was veering to the right side of the path. After contacting the railing on the right, she stopped, corrected her direction, centered the wheelchair on the path then continued driving. Although she was centered on the path, she still required frequent adjustments particularly through the right turn. Seven weeks passed between the pre-training and post-training evaluations, yet training sessions were only conducted within the last four weeks of that period. During the post-training evaluation without the sensing device Subject 3 corrected her direction on the path in a more organized and concise manner than during the pre-training evaluation. The improvement in her reaction to the contact may have resulted from either general practice in mobility during the seven weeks between evaluations, or an awareness of location in space developed by using the sensing device during training sessions, or most likely a combination of both. Although Subject 3 was not able to avoid the contact entirely when not using the sensing device during the post-training evaluation, it was significant that she was able to use the physical cue of the contact to bring her attention to task and interpret it to redirect herself on the appropriate course.

When using the sensing device during the training sessions Faith (Subject 3's PT) stated that the sensor seemed hypoactive at times, not sounding when expected. It did beep however when the subject hit her lap tray due to an athetoid movement in her arms. There was no obvious trend in the relation between the time needed to complete the training path and the number of device activations recorded. During three of the four training sessions there were one or more solid light/sound activations from the sensor, showing that Subject 3 was approaching the railings closely at least once throughout the training path. Despite any veering toward the railings no contacts were made during the training sessions.

During the post-training evaluation with the sensing device, Subject 3 made no contacts with the railings, and only caused the device to activate twice: once during drift and again at the end of the path when the automatic door swung toward her while opening. The evaluators described her driving as being more centered on the path and stated that the drift seen in the post-evaluation with the device was smoother than the veer observed in the post-evaluation without the sensing device. The sensing device seemed to be successful in bringing Subject 3's attention to task, since her overall mobility was said to be more controlled and movement off course as well as self-correction were less severe.

When investigating the difference in time needed to complete the evaluation path, both post-training evaluations proved shorter than the pre-training evaluation (Figure 12). The post-training evaluation without the sensing device took about 20% less time to complete

than the pre-training evaluation. And the post-training evaluation with the sensing device took approximately 10% less time than the pre-training evaluation.

The reduction in time needed to complete the path could have been affected by a combination of factors including: general practice in mobility between evaluations resulted in more efficient driving, and also that the weather was considerably colder during the post-training evaluation and could have motivated the subject to get inside of the school more quickly. The post-training evaluation with the sensing device may have taken more time than the evaluation without the device because the subject needed to stop to adjust her hair and gloves and also to tilt her chair to rest. The post-training evaluation with the sensing device was conducted just after that without the device, making it more likely that Subject 3 would experience fatigue during the second run.

In summary, the unshielded sensing device setup, paired with a slow wheelchair driving speed (drive 1) seemed to produce the most useful feedback for the driver. Subject 3 showed greater attention to task and deviated less from the center of the path when the device was mounted on her wheelchair. This suggests that the sensing device had a direct influence in the improvement of her mobility, since comparing the two post-evaluations excludes the factor of practicing mobility over time. Although the subject was unable to avoid contact during the post-training evaluation when the device was removed from her chair, she used the physical cue of the railing contact to redirect herself to the center of the path. It appeared that her performance improved through internalization of external cues, in comparison with her pre-training evaluation when she slowly veered back on

course after making contact with the railing. Subject 3 did show increased independence in driving by her overall improvement in mobility and also by staying on the right side of the path more often (as noted by her OT, Donna). Her ability to remain to the right during driving is ideal for better flow of traffic when a pedestrian approaches from the opposite direction.

Chapter 5

Discussion

Discussion of the Powered Mobility Protocol and its Use

Overall, the powered mobility protocol functioned well in measuring the subjects' performance during each stage of the pilot study. Filling out the single-page data sheet was easy and ensured that all of the evaluator's observations were recorded in one place. The evaluators' comments proved to be most useful in analyzing the results. However, the objective measures of the number of contacts made and amount of time taken to complete the path were problematic in evaluating the effect of mobility training. The sterile environment in which the evaluations were conducted also affected the outcome of the results.

The three subjects that participated in the case studies were considered to be challenged drivers, with difficulty in processing increasingly complex information. Since the evaluation paths were designed to reduce both visual and auditory distractions, this allowed the subjects to perform at higher-than-expected levels. It was initially anticipated that the number of contacts made with obstacles along the evaluation path would be higher for drivers struggling with basic maneuvering skills. Yet only Subject 3 actually made contact while driving and even then it was only once throughout the entire path. As a result, this metric was not as telling as expected. The amount of time taken to complete the path varied depending on the subject's endurance, distractibility, and level

of performance during each evaluation. It was necessary to use the explanations provided by the evaluators' comments in order to understand the significance of the objective measurements.

Although most of the evaluators' comments were helpful in describing the data collection sessions, there seemed to be a trend during the training sessions for the evaluators to comment more so on the performance of the device than the subject's driving ability or their response to the device. This made it difficult to establish how the subject performed in mobility during the training sessions, but helped in determining how the sensing device could be improved.

Another observation made from the data was that the total number of device activations varied significantly between evaluators. For example, for Subject 1 the total number of activations decreased from greater 80 for training session 1 to 27 for training session 3 (Table 4). Although the activations may have decreased as the subject learned how to respond to the sensing device cues, it is unlikely that the activations would be reduced by approximately 1/3 within the first three training sessions. There may have been initial confusion about how the ranging device functioned. As obstacles are first approached the activation of the device results in intermittent beeps rather than a solid continuous tone. It is probable that a single device activation resulted in multiple beeps from the auditory alert. As a result, while the evaluators were first becoming familiar with how the device functioned, they may have recorded the total number of beeps, rather than the total number of activations. It was clear that distinguishing between activations during

motion was difficult because Subject 1's OT/PT team attempted to combat this by asking the subject to stop each time the device activated. This may have been the reason for the reduction in the total number of device activations recorded for the last three training sessions.

The sensing device used in this study provided the most useful feedback when the sensor was unshielded and used at slower speeds. A similar sensing device, more appropriate for the range needed for this application, could potentially aid in powered mobility training at MHS by providing a tool for the driver to help them stay on task and learn how to redirect their position in space to continue on the correct course of travel. The detection range for a sensing device used in powered mobility should be limited to about 0-3 feet. This would allow the wheelchair driver to maneuver through the path but not to veer into obstacles alongside or in front of them. Also since some of the subjects being trained in powered mobility may knock their lap tray during training, it is also important that the sensing device being used is unaffected by being bumped. Although Doppler sensors are supposed to function well under these circumstances (Table 2) the ROSS sensor did activate due to an athetoid movement during training. Infrared sensors could be a viable alternative to Doppler sensors.

Also, increasing the length of time over which the training sessions are conducted may aid in allowing the subject to internalize the auditory cues given by the sensing device. Although unintentional, Subject 3's training sessions were conducted over a four-week period while both the other subjects completed training within two weeks. It is possible

that Subject 3's improvement in mobility was most obvious because she had a longer amount of time to learn the meaning of the sensing device cues and to use that knowledge when driving without the device.

Chapter 6

Conclusions

The results of this pilot study have shown that the pre-training, training, and post-training organization of the study was an effective structure for the mobility training protocol.

The method of data collection for each stage was simple and efficient. However, the objective metrics chosen for determining improvement in mobility proved to be insufficient considering the skill level of the subjects involved. Comments provided by the evaluators were the most useful measurement of progress made in mobility skills.

It appears that a ranging device, which provides useful auditory feedback, can potentially be effectively used in the powered mobility training of children with disabilities.

Although the obstacle-sensing device used in this study did not have an ideal functional range for this application, it was able to be modified to provide useful feedback to Subject 3 and served as a tool for increasing attention to task for both Subjects 1 and 2.

Marginal wheelchair drivers who struggle with basic mobility skills can potentially benefit from the type of feedback provided by a ranging device, since it often acts as the necessary reminder to redirect travel but is not as descriptive as a verbal command that might specify direction. It is probable that marginal wheelchair drivers are able to internalize some of the sensing device cues such that their performance improves when the sensing device is removed from their wheelchair.

Defining the evaluation path to reflect the ability of the study's participants is crucial in fairly evaluating their mobility performance. The evaluation path used in this pilot study was effective for measuring performance of basic wheelchair skills and did not require complex maneuvering skills for the participants to successfully complete the path. Rather, the path was simple in layout and was controlled to minimize auditory and visual stimulation other than the cues provided by the sensing device. There are indications that for Subjects 1 and 2 the path may not have been challenging enough to reveal effects due to mobility training. Since the number of distractions along the path was reduced significantly, Subjects 1 and 2 generally performed at higher-than-expected levels with greater attention to task.

Also, when testing performance in mobility with and without the sensing device after just two weeks of training, performance with the sensing device is expected to be better as long as the sensing device is providing useful feedback to the driver. It is hypothesized that a more longitudinal study, extending the training period to 4-6 weeks, would potentially allow the subject's performance without the device to approach the performance with the device over time. In this way, removal of the device would not result in a regression of driving skills.

Suggestions for improving the structure and methods of this study are discussed in the following chapter.

Chapter 7

Recommendations for Future Work

There are several modifications that can be made to this pilot study to improve the method of data collection and the value of the results. The changes mentioned here include using an alternate sensing device, redefining criteria for qualified candidates participating in the study, and eliminating variations in data between different evaluators.

An appropriate sensing device for use in powered mobility training at MHS should activate within a relatively small detection zone: 0 to approximately 3 feet, depending on the location of the object relative to the centerline of the sensor. Ideally when traveling parallel to an obstacle (for example a wall) the sensor should not activate until the wheelchair approaches the obstacle within 6-8 inches, to allow for maneuvering on the path but to deter veering. Likewise if the obstacle is directly in front of the sensor, it should activate when the obstacle is detected about 3 feet away, allowing the driver time to stop and redirect their course. Rather than beeping as the object is approached, only a solid tone should result from the sensor detecting an object. It is expected that users will perceive this type of feedback as being more consistent. This would also better define the number of activations so that there would not be confusion between the number of beeps heard and the number of times the sensor activated when an obstacle was detected.

Since each of the reverse-sensing systems initially researched (Chapter 2) have detection ranges that extend farther than 3 feet, two other sensing devices were researched as possible alternatives for use in future mobility training. Infrared sensors are of particular

interest since they are supposed to function properly regardless of being bumped or knocked (Table 2) which is an important feature for use of the device with subjects that experience uncontrolled (athetoid) movements in the upper extremities. The two infrared sensors discussed here were not designed for use in reverse-sensing systems and therefore have a more appropriate detection range for use in powered mobility training.

A commercially available device which has similar characteristics is the Hand Guide™ device, designed for use in as a mobility aid for the blind (www.guideline-technologies.com, 2005). This device uses infrared sensors to detect objects within a range of 4 feet. The horizontal angular range is not defined by the manufacturer, but it can be assumed that it is fairly narrow since the website suggests sweeping the device back and forth in the direction of travel to detect objects. Although this device has a more appropriate range for this application, it is difficult to tell if the linear motion of the wheelchair would be sufficient for activating the sensor. The ‘features’ link on the Guideline™ Technologies website states that the device can alert the user of obstacles with an audio mode that uses pitch variation as distance changes, or a vibration mode(www.guideline-technologies.com, 2005). The auditory alert is described as a chirp which may cause the same difficulties in distinguishing between activations, as seen with the ROSS device.

If it were feasible to create a ranging device, the Sharp GP2D12 infrared sensor could potentially be used in designing a ranging device that is appropriate for powered mobility training. This is an infrared distance sensor which takes a “continuous distance reading

and reports the distance as an analog voltage with a distance range of 10cm (~4") to 80cm (~30")" (www.acroname.com/robotics/parts/R48-IR12.html, 2005). The benefit of building the sensing device is that it can be designed so that the sensor's voltage output can activate an auditory alert device at the distance of interest for this application. If the Sharp GP2D12 sensor is used, the maximum range at 30" would cause an analog output voltage of about 0.4 V (according to the sensor's data sheet on the website) so the auditory alert device would have to be adjusted to sound at that input voltage.

The use of such a sensing device would be best for training students who are challenged by the basic maneuvering skills investigated in this study: traveling parallel to a wall (or railing), 90° right and left turns, and approaching an obstacle and stopping before reaching it. More complex powered mobility skills, such as maneuvering over a curb, would be difficult to teach using cues only from a ranging/sensing device because more specific directions from the mobility trainer may be required. The criteria for qualified candidates should therefore state that the powered mobility challenges experienced by the participant must pertain to basic maneuvering skills and that the feedback of the sensing device may be helpful in improving that skill or task. In other words, the sensing device cues might provide the necessary cognitive assistance in alerting the subject to the task at hand which would aid the subject in performing basic maneuvering skills better.

The data collection and training methods used in this study could be continued. It would be interesting to determine if lengthening the time period of the training sessions from two to four weeks would aid in the subject's internalization of the cues provided by the

sensing device. Of course this would make the selection of qualified candidates more complex since the subjects placed in the 2-week training group would have to be otherwise comparable to those in the 4-week group to be able to draw conclusions between them. Conducting a more longitudinal study would be valuable to determine the necessary length of the training sessions for the subject to achieve a maximum performance without the use of the device.

Finally, another suggestion for altering the data collection procedure would be to utilize one person, experienced in powered mobility, to record data for all of the subjects through each stage of the study so as to eliminate variations in measurements between different evaluators. The intention would be that the subject's OT/PT team would still conduct the pre-training, training, and post-training evaluations, but the data collection sheets would always be completed by the same evaluator. Unfortunately this would become very time-intensive for a single evaluator. An alternative for eliminating variations would be to specifically define the metric (number of contacts, number of device activations, amount of time) directly on the data collection sheet to act as a constant reminder for each evaluator. For example, if the sensing device activation results in a continuous tone, then one 3-second beep would be equivalent to one activation. This would ensure that the total number of device activations are counted in the same way by each evaluator. Outlining the expectations of the evaluators in a larger document that describes the study as a whole (as in Appendix C) is also necessary, but does not suffice as instructions for everyday data collection.

Appendix A: Private Correspondence to the MHS Committee for Human Studies

The following proposal was written by Gary Rabideau, the MHS Internal Sponsor, and submitted to the MHS Committee for Human Studies for review and approval:

1. Introduction:

A number of patients are currently being trained by MHS clinical staff to improve their skills towards driving a power wheelchair with greater independence. While power wheelchair driving is an important skill set for the MHS patient population, there is little empirical research documented in the literature which examines driver training techniques and strategies. Many MHS therapists are providing power mobility training to their patients. However, the protocols are generally not standardized and many of the techniques used are intuitive with few tested approaches to rely upon. One integrated driving skill that is difficult to teach is the cognitive vigilance and attention to task which is necessary for safe and consistent driving. One of the principal goals for MHS patients learning to drive is to reduce their reliance on verbal cuing from an attendant and to rely more on external environmental cues which would alert them to obstacles in their path and refocus their attention on the driving task. The Worcester Polytechnic Institute (WPI) research team proposes to investigate a technique whereby an auditory/visual feedback device (an obstacle sensing system which emits a signal as the WC approaches an object within 4-5 feet) is attached to a power wheelchair and used in the training process. The device would provide trainees with a cue that could potentially become internalized and allow the user to be more self-reliant in driving. The feedback device is a commercially available product that has been thoroughly tested and patented in the automobile industry. The Rehabilitation Engineering Dept. staff will assist in the adaptation of this device for use on a wheelchair. A small sample of MHS patients would be identified to use this device in closely supervised training sessions with their primary therapy teams to determine if it ultimately improves their driving ability and safety.

2. Specific Aims:

The goals of this study are to:

- Identify the ability of the obstacle sensing device to provide an MHS patient with effective, useable feedback during power mobility training.
- The study is designed to post test the individual both with and without the device following training to determine if:
a) use of the device has improved a driver's skill set and b) if there is carryover/internalization of the benefits of this device, such that a user demonstrates improved skills once the device is removed.

3. Experimental Protocol:
The experimental protocol will adhere to the following sequence:
 - I. Subjects will be supervised and graded by trained MHS clinicians in the driving of their power wheelchairs over a common standardized course on the MHS campus. Target behaviors to be monitored will be such variables as # of contacts with objects in their environment, # of verbal cues required to prevent contact and correct for deviations, and # of maneuvers to complete 90 degree turns successfully.
 - II. The subjects will then participate in structured therapy sessions dedicated to power mobility training using the ranging device for feedback. These sessions will all be conducted on the Massachusetts Hospital School grounds by a patient's primary therapist (in the context of their standard treatment sessions). The period of training will last approximately two weeks for each patient.
 - III. The subjects will then be re-assessed on their driving performance along the same standardized evaluation route using the original assessment tool. They will be graded on their performance during two post training trials, one using the ranging device and the other with the ranging device removed from their power wheelchair.
4. Interpretation of Data:
The data will be interpreted by the principal investigator in consideration of multiple single case study designs whereby each subject will serve as their own control. While the ability to generalize results from the study will be limited, the trends or insights gained from the individual case studies will lend to further investigation.
5. Risks:
Each subject's participation will take place under close supervision by the MHS therapist assigned to that patient. The procedures are deemed totally non-invasive and present only the standard risks currently faced by all participants in a typical power mobility training session performed at MHS. All technical applications and setups of the device will be performed and monitored by members of the MHS Rehabilitation Engineering Dept. (qualified to provide adequate safety and performance oversight).

6. Potential Benefits:

The potential benefits for participants in this study and to the future efficacy of MHS power mobility training programs is significant, while the risks to these individuals is minimal. The potential benefits would include, but not necessarily be limited to:

- Participants may gain a new sense of responsibility and enrichment from participating in a structured, novel experience such as this study.
- Participants may potentially improve skill sets in power mobility as a result of using this device and therefore be more self-reliant and less dependent on others for safe functional mobility.
- MHS therapists may derive new insights and training strategies from use of this device which would be beneficial towards future power mobility training of MHS patients.
- The Rehabilitation Engineering Dept. will gain experience in the use of this sophisticated technology and may develop strategies for modifying and applying this type of equipment to benefit future power mobility trainees.

5. Informed Consent:

The attached informed consent document will be presented and explained to the parents/guardians of all potential participants in the study. Only those patients with a signed informed consent will be eligible to participate.

Appendix B: Parental Consent Form

INFORMED CONSENT FOR PARTICIPATION IN THE STUDY TITLED:

“THE IMPACT OF USING AN OBSTACLE SENSING SYSTEM IN THE POWER WHEELCHAIR TRAINING OF DISABLED CHILDREN”

I. Description and explanation of procedure

The Massachusetts Hospital School's (MHS) Rehabilitation Engineering Department (directed by Gary Rabideau) is collaborating with a Masters Degree graduate student (Lisette Manrique) from Worcester Polytechnic Institute (WPI) to test a strategy for teaching power wheelchair mobility skills to new learners. The project team has researched a simple electronic device which attaches to standard power wheelchairs. This device can detect obstacles in a wheelchair users' environment and will give them feedback if the obstacles are approached closely. The team plans to identify approximately five patients at MHS who face challenges driving their power wheelchair (such as limited attention span or perceptual impairments) and who could potentially benefit from mobility training using this device. The research team will work closely with patients' primary therapists to evaluate the current driving skills of these subjects. The patients would then use the obstacle sensors under close supervision while undergoing mobility training with their therapists. After a brief period of training the patient would then be re-evaluated for his/her driving abilities to determine if there has been a change in their skills (primarily their ability to drive more alertly and directly from one location to another).

The testing and training phases will take place within a seven to ten day period. During this phase the sensing device will be temporarily mounted to the wheelchair. After this period the device will be completely removed and the participant's wheelchair will be unaltered and unaffected from its original condition.

II. Risk and discomforts

The potential risks or discomforts to participants in this study are deemed very minimal. The evaluation and training phases of device use by the participant will be closely supervised by trained therapists who will monitor the patient's safety and response. The few remote risks to be considered would be:

- 1) A participant may find the feedback from the device confusing or disorienting and consequently demonstrate decreased driving ability or attention. In these instances the monitoring therapist would judge whether to discontinue or change the structure of the training sessions.
- 2) The sensing device could malfunction and fail misleading the patient regarding obstacles in his/her surroundings. Again, this will be closely monitored by the trainers and possible interventions would include: explaining the equipment status/failure to the participant, potentially discontinuing the session or modifying/repairing the device.
- 3) Participants would be clearly informed that at the end of the final evaluation the device would be removed from their wheelchair. All efforts

will be made to minimize disappointments if the device is found desirable to the patient and yet must be discontinued. Considerations for future provision of such a device will be given to those situations where it is deemed particularly beneficial.

III. Potential benefits

Participation in this study may result in benefits for the individual as well as the broader population of challenged power wheelchair users. Individuals involved in the study may improve their power wheelchair driving skills (attention to the task; alertness while driving in their environment) that could carry over into everyday functional mobility. As well, therapists participating in the study may learn strategies and techniques that will enhance their ability to train other power wheelchair users toward greater independence and self-reliance. The results of the study will be analyzed and compiled in a Masters Thesis (all participants' personal information will be kept in strict confidence) which would be available for other professionals who wish to further develop these training approaches.

IV. Alternatives

There are various approaches for power mobility training that therapists can choose to assist new or challenged drivers. This study analyzes the application of one such approach which has not been extensively explored in the literature. There are variations of sensing devices that could be utilized. This device is one which is commercially available on the market place (typical application is for motor vehicle use), relatively economical and can be readily mounted/interfaced with a power wheelchair. The study is designed to explore the concept of using a sensing device in this application; future studies could examine alternative sensing devices and training strategies.

V. Confidentiality

The names and personal identification data for all participants in this study will be held in strict confidence by the investigators and the MHS staff involved. No participants' names or personal identification information will be published in the final Masters Thesis document.

VI. Resources for informing subjects

Gary Rabideau, Director of the Rehabilitation Engineering Department is the sponsoring investigator for the Massachusetts Hospital School on this project. He is familiar with and has provided equipment services to each participant in the study while at MHS. He can be contacted directly by phone to provide more information or answer any questions regarding this study. Mr. Rabideau is collaborating with the principle investigator Lisette Manrique, a biomedical graduate student from the Mechanical Engineering Department at Worcester Polytechnic Institute. Her faculty advisor is Professor Allen Hoffman of WPI. They can be reached through Mr. Rabideau to address any additional issues or concerns.

VII. Conditions of participation

Participation in this study is strictly voluntary and any refusal to participate will in no way affect the extent or quality of services provided to the individual at the Massachusetts Hospital School. The participant will be fully informed of all aspects and phases of the

study throughout their period of involvement and they may choose to cease participation at any time in the process without penalty or consequences whatsoever.

VIII. Other Considerations

Participants in the study will continue to receive the full complement of therapies and MHS services during and after the study as outlined in their Plan of Care. Results of participating in the study may vary considerably on an individual basis. The Plan of Care Teams will consider how outcomes from this study might be applied to improve driver training on an individual basis.

IX. Consent

I have fully explained to _____ the nature and purpose of the above-described procedure and the risks involved in its performance. I have answered and will answer all questions to the best of my ability. I will inform the participants of any changes in the procedure or the risks and benefits if they should occur during or after the course of the study.

Gary Rabideau, MS, OTR/L
Director of Rehabilitation Engineering
Massachusetts Hospital School

I have been satisfactorily informed of the above-described procedure with its possible risks and benefits. I give permission for my child's participation in this study. I know that Gary Rabideau and his associates will be available to answer any questions I may have. If I feel my questions have not been adequately addressed, I may request to speak to a member of the Massachusetts Hospital School Ethics Committee. I understand that I am free to withdraw this consent and discontinue participation in this project at any time, even after signing this form, but it will not affect my child's care. I have been offered a copy of this form.

Name of Participant _____ Date _____

Signature of Participant's Parent/Guardian _____ Date _____

Witness to Signatures _____ Date _____

Appendix C: Private Correspondence to MHS Clinical Staff

The following summary of the mobility study reported here was written by Gary Rabideau and distributed to the clinical staff that participated in data collection:

“Thank you for your interest in supporting the Power Mobility Training Study being done at MHS in collaboration with a Worcester Polytechnic Institute graduate student, Lisette Manrique. Lisette has worked with us to develop a multiple single case study design for testing the impact of using an obstacle-sensing device on power mobility training with disabled children. The study has been reviewed and approved by the MHS Ethics Committee (see attached Protocol for more detail). We believe that this study has significant potential benefits for all parties involved. Participating patients have the potential to acquire new power mobility skills which may increase their function, safety and independence. Therapists may develop new strategies and training techniques to facilitate this patient benefit. The original groundwork and literature review performed by Lisette has already reaped useful information for developing power mobility training protocols.

A general outline of the study and the expectations for participating clinicians are outlined below. We greatly appreciate any effort to integrate the procedures of the study into your treatment plan/ therapy sessions for your patient. After review of this general outline, we would like to meet with you prior to the participation of your patient in the study. Please feel free to contact us directly at any time for more information.

I. Research Design:

Four to five MHS patients have been identified as qualifying for participation in this study. Each subject will be pre-tested, trained and then post tested on a power wheelchair mobility task. The individual case studies will be done sequentially with each subject participating in a two-week process. The pre-test evaluation will be conducted by Gary, Geoff and Lisette. The patient will then participate in a series of structured power mobility training exercises/sessions with his/her primary therapist(s) using a commercially available feedback device mounted to the wheelchair by the Rehabilitation Engineering Dept. This device provides auditory and visual feedback when a user approaches obstacles closely in his/her environment. After the training series, Gary, Geoff and Lisette will post-test the patient to determine the impact of training with the device on the performance of a specific mobility task.

II. Subjects:

Some of the qualifying criteria for subjects participating in this study are
1) subjects must own their own power wheelchair and be deemed able to drive the WC without physical assistance (some level of supervision may

be required for safety and direction) 2) subjects must have some documented history of power mobility challenges, foremost (for purposes of this study) due to cognitive or perceptual impairments such as delayed initiation, distractibility or diminished cognitive vigilance. Subjects who are generally responsive to verbal cuing for redirection and have shown the capability of integrating new learning are deemed optimal for this study.

III. Timeline of Study:

Participants will be pre-tested on a Friday. Trainings will begin the following Monday and be performed over the subsequent nine business days through the following Thursday. Ideally subjects will participate in six to ten training sessions over the course of these nine days (the training structure may lend to two sessions in a given day). The subject will then be post-tested on the Friday after the last Thursday training. On that same day the next subject in the sequence will be pre-tested and then follow the same protocol as the first subject. The target date for the first pre-test is Friday, September 17th. Subsequently, the post-test for that subject will be Friday, October 1st which would also be the pre-test for the second subject and so on. The study will be completed approximately mid November after four to five subjects have been processed.

IV. Training Structure/Protocols:

We are requesting that MHS Plan of Care therapy teams participate in the training of their patients who are subjects in the study. During the training phase therapists may conduct six to ten training sessions over a period of approximately nine business days. The sessions should last approximately thirty minutes each and would structured as follows:

- 1) Therapists will place the ranging device on the patient's wheelchair in a predetermined location and plug it into an existing power supply.
- 2) All training sessions should then begin with orienting a patient to the device and the way it operates. The therapist can demonstrate or use verbal + physical cues to show the patient how the device activates when the wheelchair approaches an object.
- 3) The training session will consist of having the patient drive a pre-determined route from point A (the patient's unit) to point B (the school). This will be the route when training is done in the morning. When training is done in the afternoon after school, the predetermined route will be from point A (the school) to point B (the dorm). Over the first one-third of the

distance of the route (to a designated point) the therapist would conduct an active training session where he/she provides verbal feedback and direction to the patient to reinforce the association between the signal from the device and its meaning (close approach to an object). The therapist may use whatever style and strategies they deem helpful to facilitate the use of the device as a beneficial tool for the patient. For the later two thirds of the predetermined training path the therapist will not provide any intervention to the patient as they proceed to point B. The therapist will explain where the patient is to go and then monitor the progress of the patient while recording some simple data on a collection form. The only intervention that a therapist should provide during this phase is if necessary to ensure the safety of the patient. In this instance, verbal or physical intervention can (and should!) be provided. The training session ends when the patient has reached his/her destination at point B. At that time the therapist would remove the sensing device from the power wheelchair and have it available for use in the next training session.

The goal of the training sessions is to assist the patient in learning the meaning of the feedback signal and to integrate this information in a way that will redirect them or keep them on task during power mobility driving. We welcome your comments and feedback at any point in this process. We anticipate that some patients may initially be confused or startled by use of this device, but it is our hope that the system will eventually become more acceptable and useful to the patient over the course of the trainings. If not, this too is very useful information. Thank you again very much for your support on this project.”

Appendix D: Janeschild's Student Information Form

**Early Power Mobility: Evaluation and Training
for the Severely Involved Client**

Name: _____
Diagnosis: _____
Date of Birth: _____
People working on Power Mobility w/ client: _____
(identify name, profession & phone number) _____
Date Program Initiated: _____
Picture/s taken of: Seating & Positioning Y N
Access & Control set-up Y N
Review Dates: _____

Identifying Information

Positioning

Power Wheelchair: _____
Seating & Positioning: _____

Placement of Joystick : R L N/A _____

Placement of Control Switch(es) } ^{date}
 1) _____
 2) _____
 3) _____
 4) _____

Drawings: (for positioning of seating, joystick or switches)

Movement and Control to operate wheelchair: (describe)

Communication:(e.g., devices, yes/no, communication boards?)

Vision: _____

Hearing: _____

Endurance: _____ Optimum Energy Time: am pm

Appendix E: Rostra Obstacle Sensing System Operating Manual

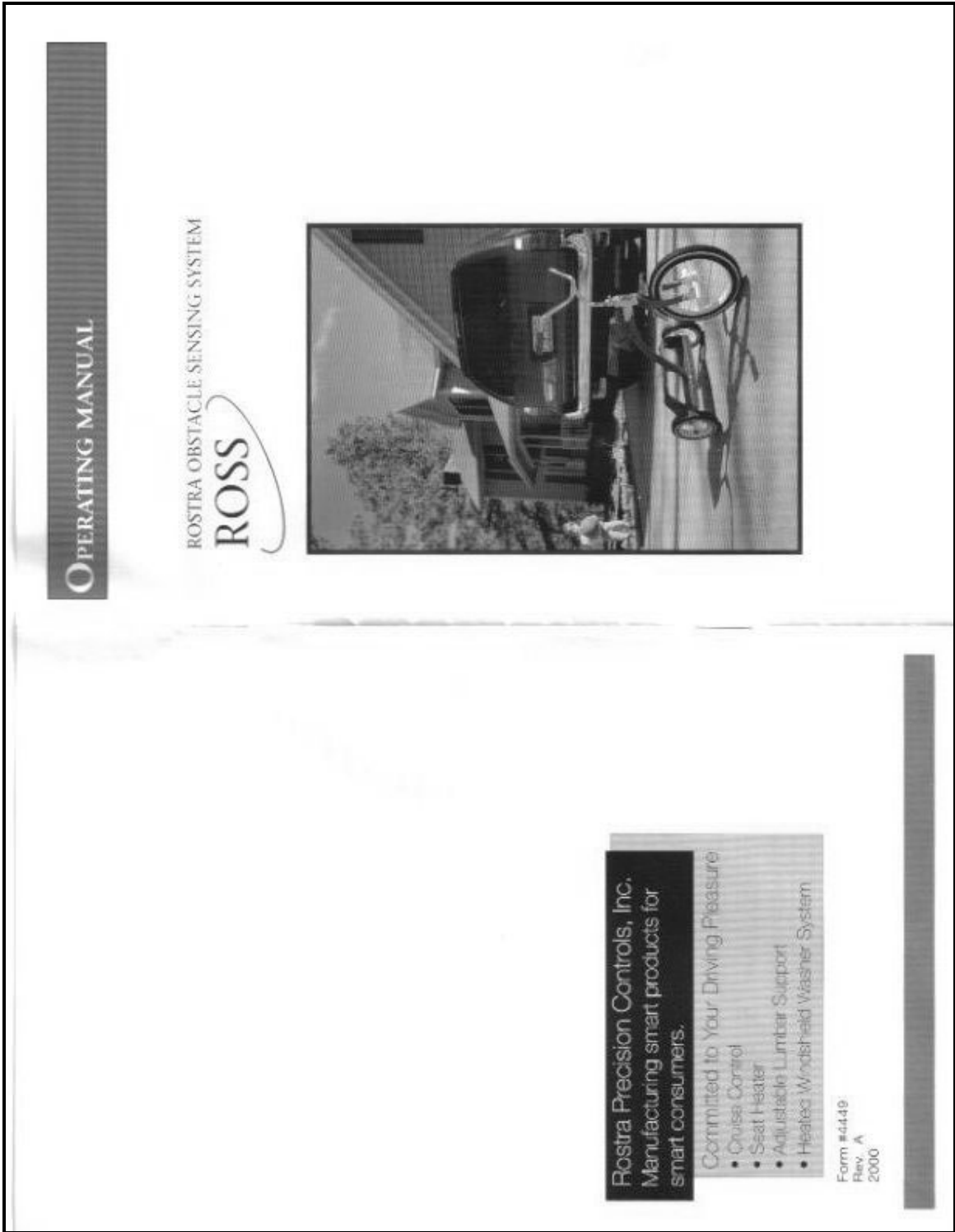

ROSTRA OBSTACLE SENSING SYSTEM



R Rostra
Precision
Controls, Inc.
2519 Dana Drive, Laurinburg, NC 28352 USA
Telephone: (910) 276-4853 • Fax: (910) 276-1354
www.rostra.com

Rostra is a Certified
QS9000 / ISO9001
Manufacturer



TABLE OF CONTENTS

System Overview	1
General Operating Instructions	2
Precautions	6
Troubleshooting Guide	7
Owner's Warranty	8

SYSTEM OVERVIEW

The Rostra Obstacle Sensing System (ROSS) is a state of the art obstacle detection system designed to alert drivers to obstacles to the rear and laterally to the left and right of their vehicle bumpers. The system uses a microwave signal to detect obstacles in your vehicle's "blind spots".

When an obstruction is detected in the sensor's coverage area, the sensor determines the distance to the obstacle. This information is then instantaneously converted into a tricolor display and an audible alert. The ROSS is not affected by adverse weather conditions such as extreme heat or cold, rain, sleet, snow, hail, mist, or fog.

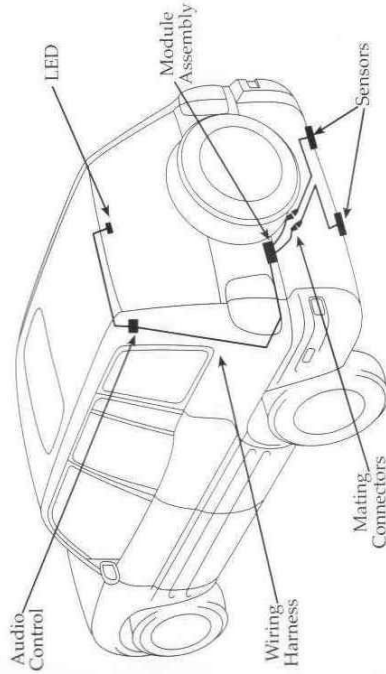

1

GENERAL OPERATING INSTRUCTIONS

Obstacle Detection

The ROSS detects obstacles up to 12 feet behind your vehicle and can also sense objects next to the rear end of the vehicle. Before the ROSS can provide obstacle alerts, the following must occur:

- The vehicle ignition must be in the "on" position.
- The vehicle must be in reverse gear.
- The vehicle or the obstacle must be moving.

The ROSS will detect obstacles within the sensor coverage area including trees, posts, buildings, animals, children's toys, plastic products, people, and other vehicles. However, obstacle density and moisture content of the object will affect the sensitivity of the ROSS sensors. For this reason, some objects may not be detected until they are closer to the rear bumper of the vehicle than the outermost detection zone. (Please see the section entitled Detection Zones.)

For example, a relatively low-density object such as a utility pole, sign, or fence post may not be detected when it is located in the Safe Zone, but may be detected in the Alert Zone. In addition, in some cases, small objects such as a ball or a small shrub may not be detected in the Danger Zone, but will be detected in the Hazard Zone. Regardless of density or moisture content, objects will be detected in either the Hazard Zone or the Danger Zone whether or not they are also detected further away from the vehicle. When an obstacle is detected in the Hazard Zone or the Danger Zone, stop your vehicle immediately.

WARNING

The ROSS system is designed to supplement other safety practices by enhancing driver awareness of difficult-to-see areas. The ROSS system does not take any automatic action to prevent accidents. Responsibility for safe operation of the vehicle remains with the driver. Failure to operate the ROSS in the manner specified in this manual could result in personal injury, property damage, or possibly death.

2

Detection Zones

The ROSS sensor coverage area is divided into four zones as shown in Figure 1.

Figure 1

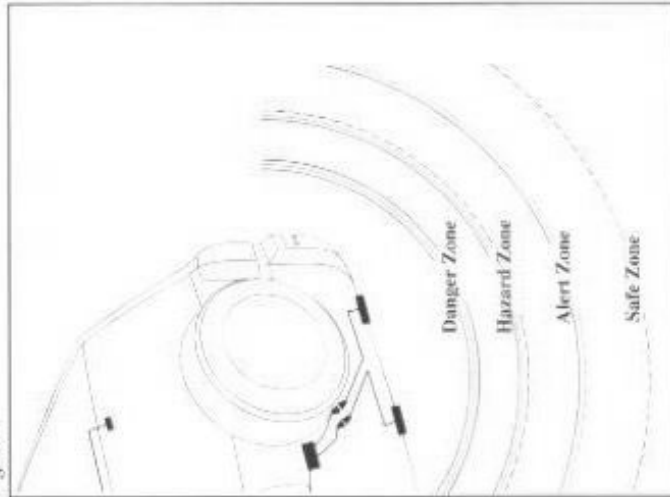

Driver Alerts

Table 1 (below) shows the types of visual and audio alerts provided by the ROSS when an obstacle is detected within each detection zone. Should obstacles be located in more than one zone, the ROSS will provide alerts for the closest one.

TABLE 1
Detection Zone Alerts

Detection Zone	LED Indication			Audio Alert
	Green Light	Yellow Light	Red Light	
Safe zone	Flashing	None	None	None
Alert zone	Solid	Flashing	None	Slow beeping
Hazard Zone	Solid	Solid	Flashing	Fast beeping
Danger Zone	Solid	Solid	Solid	Continuous tone

Operation When No Obstacles are Detected

When no obstacles are detected, the visual display unit will show a solid green light indicating that the ROSS is turned on and that no obstacles are detected.

Cleaning and Care

The ROSS does not require cleaning or special care.

Getting Started

After your ROSS has been professionally installed in your vehicle and you have thoroughly reviewed the Operating Manual, take a few moments to familiarize yourself with the ROSS by following these steps:

1. To ensure proper installation and operation of your ROSS, have another individual stand outside of the car to verify proper obstacle clearance and traffic avoidance while you become familiar with the operation of the ROSS.
2. In your driveway or in a quiet parking lot, identify an obstacle, such as a parked vehicle or a building.
3. Park your vehicle such that the rear bumper is approximately 20 feet from the obstacle.
4. With your vehicle still in "Park" and the vehicle ignition turned on, the visual display should not show any lights, nor should the ROSS sound any alerts.
5. With the brakes applied, place your vehicle in reverse gear. The visual display should show a solid green light.
6. Slowly release the brakes and begin to back your vehicle toward the obstacle.
7. As you back your vehicle closer to the selected obstacle, you should receive the audio and visual alerts outlined in Table 1. Continue backing toward the obstacle until you receive the alerts for the Hazard Zone or the Danger Zone. **Be advised that the obstacle may not appear in both of these zones** [see "Obstacle Detection"]. Once the obstacle is detected in the Danger Zone or the Hazard Zone, place your vehicle in "Park". Have the individual assisting you estimate the distance between the vehicle bumper and the obstacle.
8. Repeat this entire procedure using other obstacles. Because of differences in obstacle moisture content and density, the ROSS will detect some obstacles further away from the vehicle bumper than others. [see "Obstacle Detection"]

Please remember that the ROSS is a driver's aid. Safe operation of the vehicle is the driver's responsibility.

PRECAUTIONS

To ensure proper operation of your new ROSS, the following precautions must be considered at all times:

- The ROSS operates only while the vehicle is in reverse gear. In addition, either the vehicle or an obstacle must be moving for the driver alerts to function.
- The system sensors are affected by tall grass and may not provide proper obstacle sensing if the vehicle is located in an unmowed area such as a meadow or other off-road situations.
- The system will not detect obstacles properly if you are towing a trailer behind the vehicle in which the ROSS is installed.
- The ROSS will not work on vehicles with bumpers that are lower than 14" above the ground.
- Detection ranges may vary according to the size and material composition of various obstacles.
- The ROSS does not provide accurate obstacle detection on vehicles more than seven feet wide.
- **The ROSS will not detect obstacles under the bumper. Always inspect behind and below your vehicle prior to backing up to eliminate the possibility of property damage and bodily injury.**

Troubleshooting Guide

PROBLEM	CHECK THE FOLLOWING
LED does not display any lights	<ul style="list-style-type: none"> • Make sure that the vehicle reverse light bulbs are working properly. • Verify that the vehicle ignition is either "on" or in "accessory" mode.
LED is working properly, but system is not detecting obstacles	<ul style="list-style-type: none"> • Make sure that the vehicle is in reverse gear and either the vehicle or an obstacle within the sensor range is moving. • Confirm that the vehicle is not parked in tall grass.
Audio alert sounds, but is barely audible	<ul style="list-style-type: none"> • Check the volume control knob on the audio control unit.
Audio alert sounds but LED display is not working	<ul style="list-style-type: none"> • Check the LED harness connections to audio control unit.
Red or yellow LED light is illuminated and/or audio alert sounds, but no obstacle is present within 8 feet of the rear bumper	<ul style="list-style-type: none"> • Verify that no obstacles are located within the detection zone. • If the car is parked on a hill with the rear end of the car pointed down the hill this may be a normal condition.

If you continue to have difficulties with the operation of your ROSS, please contact our Technical Assistance Hotline at (910) 277 - 1828 between the hours of 8 AM and 5 PM (EST), Monday through Friday.

36 MONTH/ 36,000 MILE LIMITED WARRANTY

Restra Precision Controls, Inc. (the Company) warrants to the original retail purchaser of this product that should this product (or any part thereof) under normal use and conditions, be proven to have defective material or workmanship within 36 months or 36,000 miles of the original purchase, which ever first occurs, such defects will be repaired or replaced (at the Company's option) without charge for the parts. This warranty does not apply to batteries or normal wear and tear associated with the product.

To obtain repair or replacement with the terms of this warranty, the product is to be delivered with proof of warranty coverage (e.g. dated bill of sale), specification of defects, transportation prepaid, to the installing dealer and/or retailer.

This warranty does not cover costs incurred for the removal or reinstallation of the product, and / or related components, and/or damage to the vehicle's electrical system or components.

This warranty does not apply to any product or part thereof which in the opinion of the Company has been damaged through alteration, improper installation, misuse, neglect, accident, or customer abuse.

This warranty is in lieu of all other express warranties or liabilities. ANY IMPLIED WARRANTIES, INCLUDING ANY IMPLIED WARRANTY OF MERCHANTABILITY, SHALL BE LIMITED TO THE DURATION OF THIS WRITTEN WARRANTY. ANY ACTION FOR BREACH OF ANY WARRANTY HEREUNDER INCLUDING ANY IMPLIED WARRANTY OF MERCHANTABILITY MUST BE BROUGHT WITHIN A PERIOD OF 42 MONTHS FROM DATE OF ORIGINAL PURCHASE. IN NO CASE SHALL THE COMPANY BE LIABLE FOR ANY CONSEQUENTIAL OR INCIDENTAL DAMAGES FOR BREACH OF THIS OR ANY OTHER WARRANTY, EXPRESS OR IMPLIED WHATSOEVER. No person or representative is authorized to assume for the Company any liability other than expressed herein in connection with the sale of this product.

THE EXTENT OF THE COMPANY'S LIABILITY UNDER THIS WARRANTY IS LIMITED TO THE REPAIR OR REPLACEMENT PROVIDED ABOVE AND IN NO EVENT, SHALL THE COMPANY'S LIABILITY EXCEED THE PURCHASE PRICE PAID BY THE PURCHASER FOR THE PRODUCT. Some states do not allow limitations on how long an implied warranty lasts or the exclusion or limitation of incidental or consequential damage so the above limitations or exclusions may not apply to you. This warranty gives you specific legal rights and you may also have other rights, which vary, from state to state.

Customer's Name: _____
 Address: _____
 City: _____ State: _____ Zip: _____
 Dealer Name: _____
 Dealer Address: _____
 City: _____ State: _____ Zip: _____
 Date Purchased: _____ Date Installed: _____
 Make & Year of Car: _____
 Mileage at Installation: _____

Appendix F: Student Information Forms for Subjects 1, 2 and 3

Student Information Form	
Name: <u>Subject 1</u>	
Diagnosis: <u>Cerebral Palsy</u>	
Date of Birth: <u>5/5/1991</u>	
People working on Power Mobility with student: (identify name, profession & phone number)	<u>Donna, OT</u> <u>Faith, PT</u>
Picture(s) taken of:	
Seating & Positioning	<input checked="" type="checkbox"/> Y <input type="checkbox"/> N
Access & Control set-up	<input checked="" type="checkbox"/> Y <input type="checkbox"/> N
Evaluation Dates:	
Pre-evaluation <u>9/17/04</u>	Training lesson 7 <u>n/a</u>
Training lesson 1 <u>9/22/04 AM</u>	Training lesson 8 <u>n/a</u>
Training lesson 2 <u>9/24/04 AM</u>	Training lesson 9 <u>n/a</u>
Training lesson 3 <u>9/24/04 PM</u>	Training lesson 10 <u>n/a</u>
Training lesson 4 <u>9/27/04 PM</u>	Post-evaluation with device <u>10/1/04</u>
Training lesson 5 <u>9/30/04 PM</u>	Post-evaluation w/out device <u>10/1/04</u>
Training lesson 6 <u>n/a bad weather</u>	
<u>Positioning</u>	
Power Wheelchair: <u>Ranger X Storm Series 2GT</u>	
Seating & Positioning: <u>Tilt of chair is in downward-most position, flat & level with ground</u>	
Placement of Joystick: R <input checked="" type="checkbox"/> L N/A <u>Invacare (Gears 1-4)</u>	
Drawings: (for positioning of seating, joystick or switches) See photos	
Movement and Control to operate wheelchair: (describe) Just left hand on joystick	
Communication: (e.g., devices or communication boards) yes/ <input type="checkbox"/> no	
Vision: <u>glasses – nearsighted (myopia)</u>	
Hearing: <u>functional acuity for the sake of testing</u>	
Endurance: <u>functional</u>	Optimum Energy Time: <u>none specified</u>

Subject 1: Seating & Positioning and Joystick Photos



Subject 1 seated in her wheelchair, using her typical lap tray setup.



Subject 1 using the ROSS sensor with the perimeter shield.



Isometric view showing Subject 1's joystick setup on her left and the sensing device mounted underneath her lap tray.

Student Information Form

Name: Subject 2

Diagnosis: Cerebral Palsy

Date of Birth: 7/15/1986

People working on Power Mobility with student: Bill, OT

(identify name, profession & phone number) Michelle, PT

Picture(s) taken of: Seating & Positioning Y N

Access & Control set-up Y N

Evaluation Dates:

Pre-evaluation 10/1/04 Training lesson 7 n/a

Training lesson 1 10/26/04 PM Training lesson 8 n/a

Training lesson 2 10/28/04 AM Training lesson 9 n/a

Training lesson 3 10/28/04 PM Training lesson 10 n/a

Training lesson 4 n/a Post-evaluation with device 10/29/04

Training lesson 5 n/a Post-evaluation w/out device 10/29/04

Training lesson 6 n/a

Positioning

Power Wheelchair: Ranger X Storm Series

Seating & Positioning: see photos

Placement of Joystick: R L N/A Invacare

Drawings: (for positioning of seating, joystick or switches)

See photos

Movement and Control to operate wheelchair: (describe)

Right hand on joystick

Communication: (e.g., devices or communication boards) yes/ no

Vision: glasses – near and farsightedness

Hearing: functional acuity for the sake of testing

Endurance: functional Optimum Energy Time: none specified

Subject 2: Seating & Positioning and Joystick Photos



Front view of Subject 2 in his wheelchair, using his typical lap tray setup.



Close-up of sensing device with shield on lower half, mounted under Subject 2's lap tray.



Front view of sensing device setup used in mobility training for Subject 2.

Student Information Form

Name: Subject # 3

Diagnosis: Cerebral Palsy

Date of Birth: 6/10/1991

People working on Power Mobility with student: Donna, OT

(identify name, profession & phone number) Faith, PT

Picture(s) taken of:	Seating & Positioning	<input checked="" type="checkbox"/>	N
	Access & Control set-up	<input checked="" type="checkbox"/>	N

Evaluation Dates:

Pre-evaluation	<u>10/29/04</u>	Training lesson 7	<u>n/a</u>
Training lesson 1	<u>11/17/04 AM</u>	Training lesson 8	<u>n/a</u>
Training lesson 2	<u>no date</u>	Training lesson 9	<u>n/a</u>
Training lesson 3	<u>12/09/04 PM</u>	Training lesson 10	<u>n/a</u>
Training lesson 4	<u>12/16/04 PM</u>	Post-evaluation with device	<u>12/17/04</u>
Training lesson 5	<u>n/a</u>	Post-evaluation w/out device	<u>12/17/04</u>
Training lesson 6	<u>n/a</u>		

Note: The data collection sheet dated 12/16/04 PM was labeled by the evaluator as training session 5/10, although no data collection sheet was turned in for the training session 4/10, so the 12/16/04 session was treated as the fourth session.

Positioning

Power Wheelchair: Ranger X Storm Series

Seating & Positioning: see photos

Placement of Joystick: R L N/A Invacare, quadrant setup, not 360° range in joystick.

Drawings: (for positioning of seating, joystick or switches)

See photos

Movement and Control to operate wheelchair: (describe)

Right hand on joystick

Communication: (e.g., devices or communication boards) yes/no

Disarthric causing oral motor challenge. No communication board was used during any part of testing.

Vision: functional

Hearing: functional

Endurance: compromised cognitive vigilance and physical fatigue

Optimum Energy Time: none specified, potentially AM for less chance of fatigue

Subject 3: Seating & Positioning and Joystick Photos

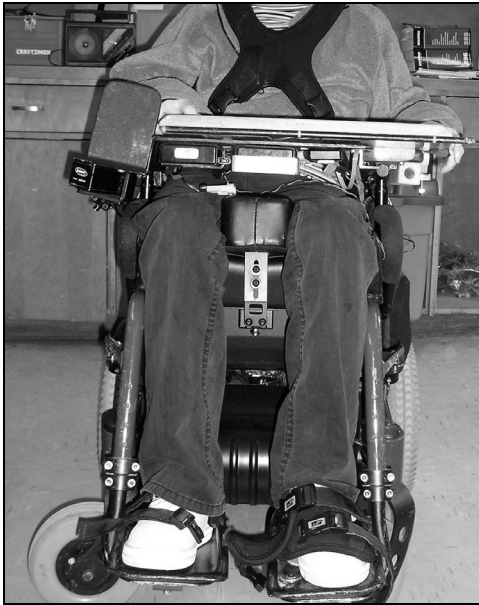

Front view of Subject 3 in her wheelchair using the lap tray designed for use in this study.



Close-up of sensing device mounted under Subject 3's lap tray. The actual device setup used in training was the unshielded sensor.



Subject 3 is shown in a tilted position in her wheelchair. This was how Subject 3 rested her back when she paused along the evaluation path.

Appendix G: Wheelchair Skills Evaluation Forms
 Pre-training Evaluation Data Collection Form

Wheelchair Skills Evaluation Form

Evaluator name: _____

Student name: _____

Date: _____

Circle one: AM or PM

Pre-evaluation
without device

Map Legend: X - Contact Point*

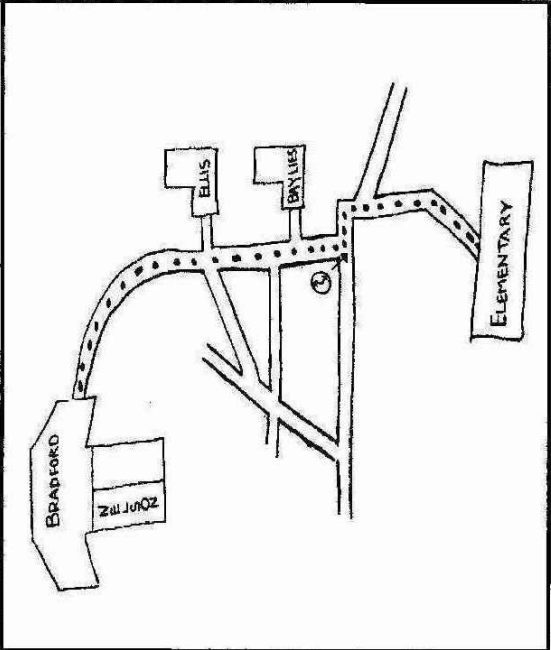

Time of start		
Time of midway point		
Time of finish		
Total # of contacts*		

* # of contacts should include physical interventions to avoid contact
 In the case of an intervention, please describe the event here:

Please indicate the direction of travel on the map.

Comments: _____

Please note if a specific source of motivation was used during evaluation. For example, if there is a person or object that the student is trying to reach or avoid.

Training Session Evaluation Form for Subjects 1 & 3

Wheelchair Skills Evaluation Form

Please check one: Training Session

Evaluator name: _____

Student name: _____

Date: _____

Circle one: AM or PM

- 1/10 O
- 2/10 O
- 3/10 O
- 4/10 O
- 5/10 O
- 6/10 O
- 7/10 O
- 8/10 O
- 9/10 O
- 10/10 O

REMEMBER TO AVOID VERBAL CUES AFTER THE FIRST 1/3 OF THE PATH

Map Legend: X - Contact Point*
O - Activation of Device

Time of start	_____
Time of midway point	_____
Time of finish	_____

Total # of contacts*

* # of contacts should include physical interventions to avoid contact

Total # of device activations

(ALL)

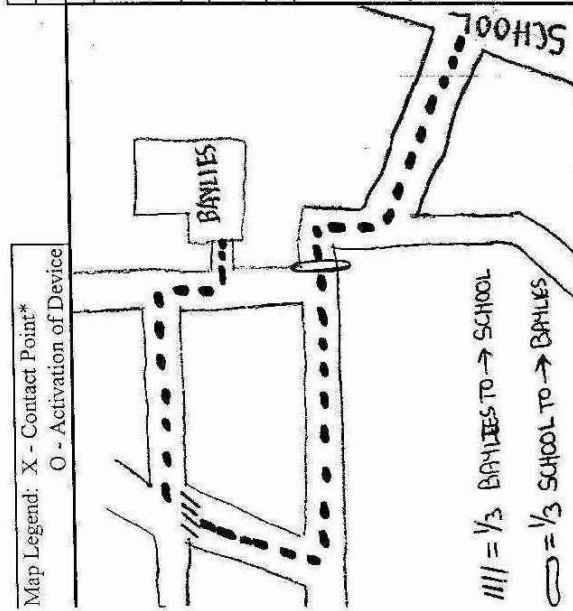

||| = 1/3 BAYLIES TO → SCHOOL

○ = 1/3 SCHOOL TO → BAYLIES

TOTAL # OF SOLID LIGHT/SOUND ACTIVATIONS: _____

Please indicate the direction of travel on the map.

Comments: _____

Please note if a specific source of motivation was used during evaluation. For example, if there is a person or object that the student is trying to reach or avoid.

Training Session Data Collection Form for Subject 2

Wheelchair Skills Evaluation Form

Please check one: Training Session

- 1/10 O
- 2/10 O
- 3/10 O
- 4/10 O
- 5/10 O
- 6/10 O
- 7/10 O
- 8/10 O
- 9/10 O
- 10/10 O

Evaluator name: _____
 Student name: _____
 Date: _____
 Circle one: AM or PM

REMEMBER TO AVOID VERBAL CUES AFTER THE FIRST 1/3 OF THE PATH

Wheelchair Gear Drive/Speed: _____

Map Legend: X - Contact Point*
 O - Activation of Device

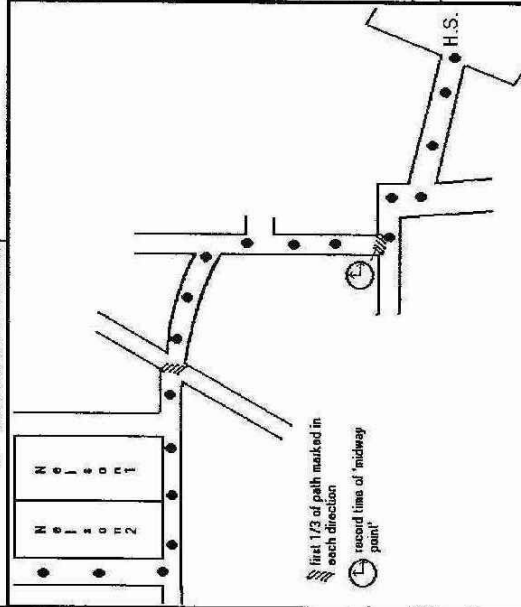

Time of start: _____
 Time of midway point: _____
 Time of finish: _____

Total # of contacts* _____
 * # of contacts should include physical interventions to avoid contact
 In the case of an intervention, please describe the event here:

Total # of device activations _____

PLEASE INDICATE THE DIRECTION OF TRAVEL ON THE MAP.

Comments: _____

Please note if a specific source of motivation was used during evaluation. For example, if there is a person or object that the student is trying to reach or avoid.

Post-training Evaluation Data Collection Form

Wheelchair Skills Evaluation Form

Evaluator name: _____

Student name: _____

Date: _____

Circle one: AM or PM

Post-evaluation
with device O
without device O

Map Legend: X - Contact Point*
O - Activation of Device

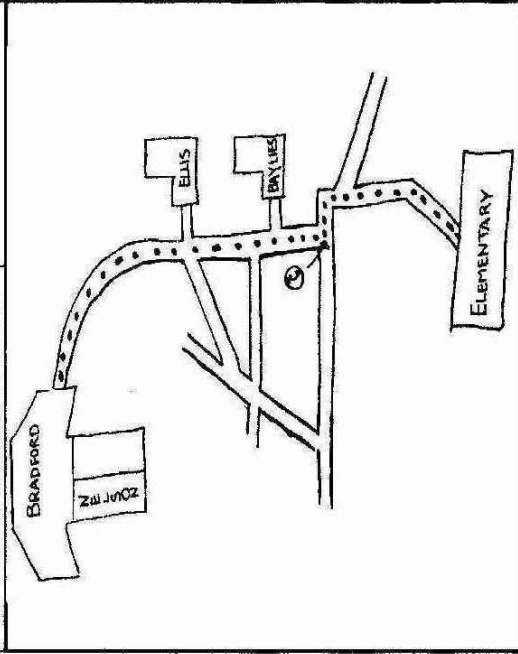

Time of start	
Time of midway point	
Time of finish	

Total # of contacts*

* # of contacts should include physical interventions to avoid contact
In the case of an intervention, please describe the event here:

Total # of device activations

Please indicate the direction of travel on the map.

Comments:

Please note if a specific source of motivation was used during evaluation. For example, if there is a person or object that the student is trying to reach or avoid.

Appendix H: Completed Evaluation Sheets
 Subject 1

Pre-evaluation without device

Wheelchair Skills Evaluation Form

Evaluator name: Gary
 Student name: [REDACTED]

Date: 9/19/04
 Circle one: AM or PM

Time of start	0
Time midway point	1:41
Time of finish	2:49

Total # of contacts* 0
 * # of contacts should include physical interventions to avoid contact

DRIVE 4 FOR ENTIRE ROUTE

Map Legend: X - Contact Point*

Please indicate the direction of travel on the map.

Comments:

Please note if a specific source of motivation was used during evaluation. For example, if there is a person or object that the student is trying to reach or avoid.

Pre-evaluation without device

Wheelchair Skills Evaluation Form

Evaluator name: Scott Renford
Student name: [Redacted]

Date: 7/17/04
Circle one: AM or PM

Time of start	0
Time of midway point	1:40
Time of finish	2:50
Total # of contacts*	0

* # of contacts should include physical interventions to avoid contact

*18.41:10 } WAS IN
12.42:50 } DRIVE 4
11.44:00 } gear T/O
 } course*

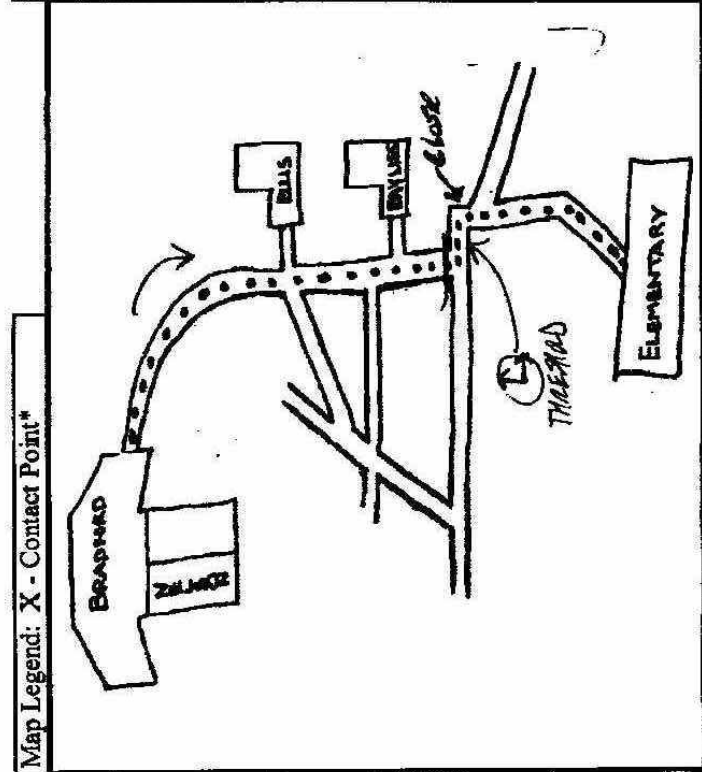

Please indicate the direction of travel on the map.

Comments: RANGED W/IN 2 1/2 FT OF LEFT SIDE FOR ROADPAD -> CHECK TOWER.
CABLE CLOSE TO FRONT END CONTACT GETTING STOPPING FOR RIGHT TURN.
W/IN 12-INCHES.

Please note if a specific source of motivation was used during evaluation. For example, if there is a person or object that the student is trying to reach or avoid.

Please check one: Training Session

1/10	<input checked="" type="radio"/>
2/10	<input type="radio"/>
3/10	<input type="radio"/>
4/10	<input type="radio"/>
5/10	<input type="radio"/>
6/10	<input type="radio"/>
7/10	<input type="radio"/>
8/10	<input type="radio"/>
9/10	<input type="radio"/>
10/10	<input type="radio"/>

Wheelchair Skills Evaluation Form

Evaluator name: DMVA McCree

Date: 9/22/04

Circle one: AM or PM

REMEMBER TO AVOID VERBAL CUES AFTER THE FIRST 1/3 OF THE PATH

Map Legend: X - Contact Point*
O - Activation of Device

Time of start	<u>0</u>
Time of midway point	<u>1:50</u>
Time of finish	<u>3:03</u>

Total # of contacts*	<u>0</u>
* # of contacts should include physical interventions to avoid contact	
Total # of device activations	<u>> 80</u>
(ALL) ?	

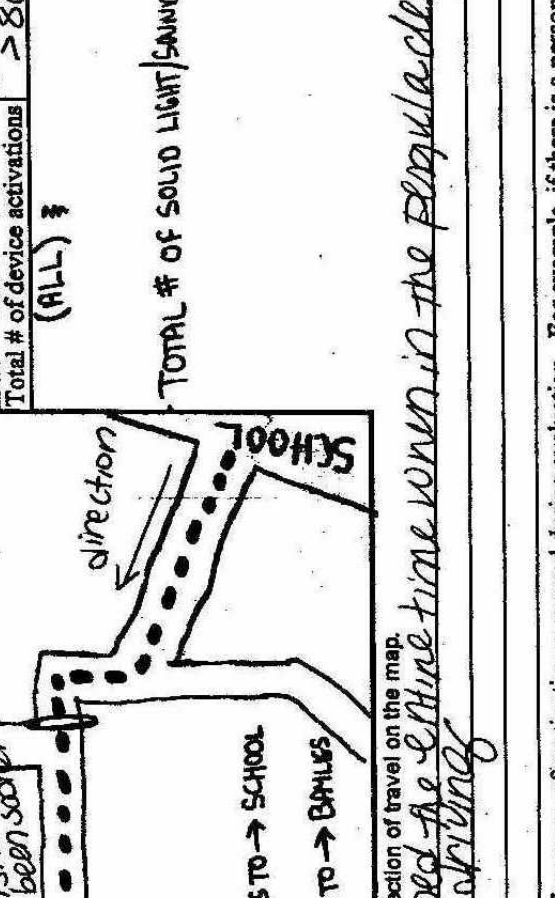

TOTAL # OF SOLID LIGHT/SOUND ACTIVATIONS: 1

Please indicate the direction of travel on the map.

Comments: Helped the entire time when in the playground despite good driving

Please note if a specific source of motivation was used during evaluation. For example, if there is a person or object that the student is trying to reach or avoid.

Please check one: Training Session

- 1/10
- 2/10
- 3/10
- 4/10
- 5/10
- 6/10
- 7/10
- 8/10
- 9/10
- 10/10

Wheelchair Skills Evaluation Form

Evaluator name: Diana McCarter
 Student name: [REDACTED]
 Date: 9/24/04
 Circle one: AM or PM

REMEMBER TO AVOID VERBAL CUES AFTER THE FIRST 1/3 OF THE PATH

Map Legend: X - Contact Point*
 O - Activation of Device

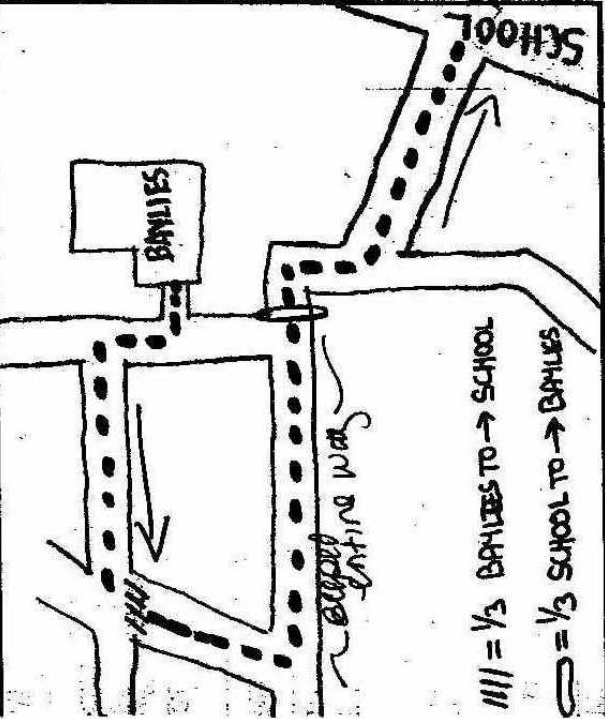

Time of start	9
Time of midway point	1:10
Time of finish	2:15

Total # of contacts* DM > 60
 * # of contacts should include physical interventions to avoid contact

Total # of device activations > 60
 (ALL)

TOTAL # OF SOLID LIGHT/SOUND ACTIVATIONS: 5

Please indicate the direction of travel on the map.

Comments: STARTER CAN STAY BEHIND IN BEYOND

Please note if a specific source of motivation was used during evaluation. For example, if there is a person or object that the student is trying to reach or avoid.

Please check one: Training Session

1/10	<input type="radio"/>
2/10	<input type="radio"/>
3/10	<input checked="" type="radio"/>
4/10	<input type="radio"/>
5/10	<input type="radio"/>
6/10	<input type="radio"/>
7/10	<input type="radio"/>
8/10	<input type="radio"/>
9/10	<input type="radio"/>
10/10	<input type="radio"/>

Wheelchair Skills Evaluation Form

Evaluator name: Funk
 Student name: [REDACTED]
 Date: 9/24/04
 Circle one: AM or PM

REMEMBER TO AVOID VERBAL CUES AFTER THE FIRST 1/3 OF THE PATH

Time of start	0:00
Time of midway point	1:26
Time of finish	3:18

Map Legend: X - Contact Point*
 O - Activation of Device

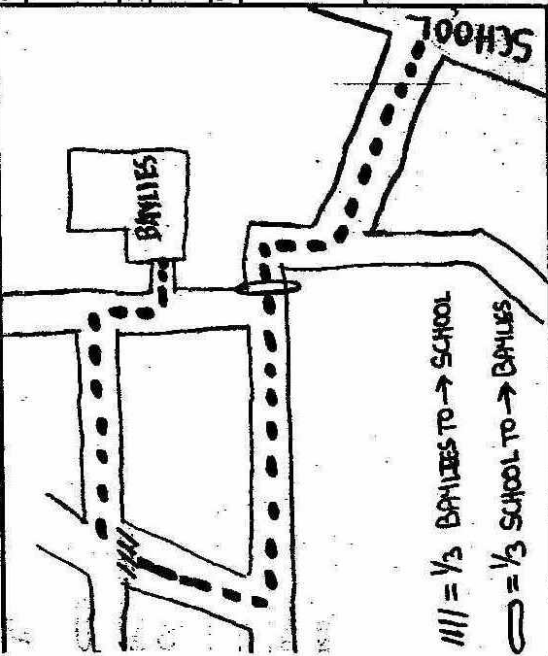

Total # of contacts* 0

* # of contacts should include physical interventions to avoid contact

Total # of device activations 27

(ALL)

TOTAL # OF SOLID LIGHT/SOUND ACTIVATIONS: 13

||| = 1/3 BANKS TO → SCHOOL

— = 1/3 SCHOOL TO → BANKS

Please indicate the direction of travel on the map.

Comments: PT told to stop driving & help to follow through 9/10 time

Please note if a specific source of motivation was used during evaluation. For example, if there is a person or object that the student is trying to reach or avoid.

Wheelchair Skills Evaluation Form

Please check one: Training Session

- 1/10
- 2/10
- 3/10
- 4/10
- 5/10
- 6/10
- 7/10
- 8/10
- 9/10
- 10/10

Evaluator name: F. V. H.
 Student name: [REDACTED]
 Date: 7/27/07
 Circle one: AM or **PM**

REMEMBER TO AVOID VERBAL CUES AFTER THE FIRST 1/3 OF THE PATH

Map Legend: X - Contact Point*
 O - Activation of Device

Time of start	0
Time of midway point	1:10
Time of finish	3:42

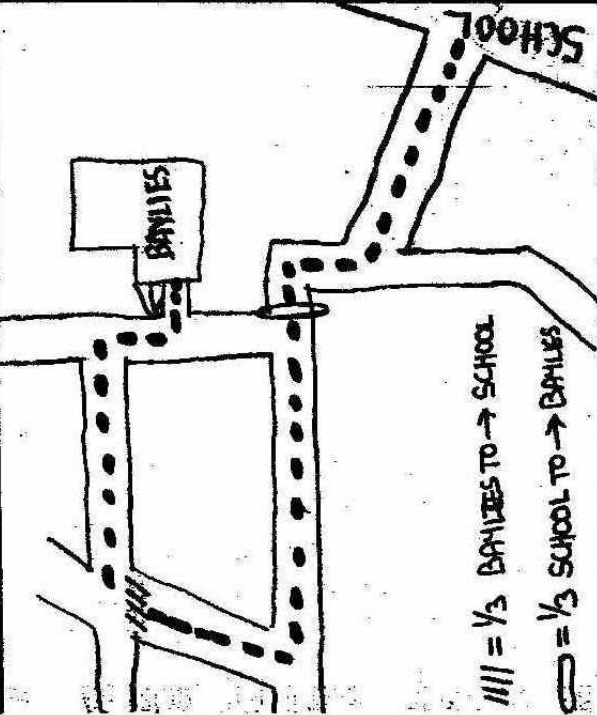

/// = 1/3 BAYLIES TO → SCHOOL
 ○ = 1/3 SCHOOL TO → BAYLIES

Total # of contacts* 0
 * # of contacts should include physical interventions to avoid contact

Total # of device activations 24
 (ALL)

TOTAL # OF SOLID LIGHT/SOUND ACTIVATIONS: 1

Please indicate the direction of travel on the map.

Comments: although it only beeped 25x, the duration of noise lasted throughout the time in purples. It was 24x of starting + stopping

Please note if a specific source of motivation was used during evaluation. For example, if there is a person or object that the student is trying to reach or avoid.

Wheelchair Skills Evaluation Form

Please check one: Training Session

1/10	<input type="radio"/>
2/10	<input type="radio"/>
3/10	<input type="radio"/>
4/10	<input type="radio"/>
5/10	<input checked="" type="radio"/>
6/10	<input type="radio"/>
7/10	<input type="radio"/>
8/10	<input type="radio"/>
9/10	<input type="radio"/>
10/10	<input type="radio"/>

Evaluator name: [Redacted] Date: 9/30/04
 Student name: [Redacted] Circle one: AM or PM

REMEMBER TO AVOID VERBAL CUES AFTER THE FIRST 1/3 OF THE PATH

Map Legend: X - Contact Point*
 O - Activation of Device

Time of start	<u>0</u>
Time of midway point	<u>2:17</u>
Time of finish	<u>4:07</u>

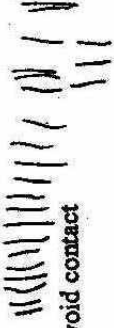
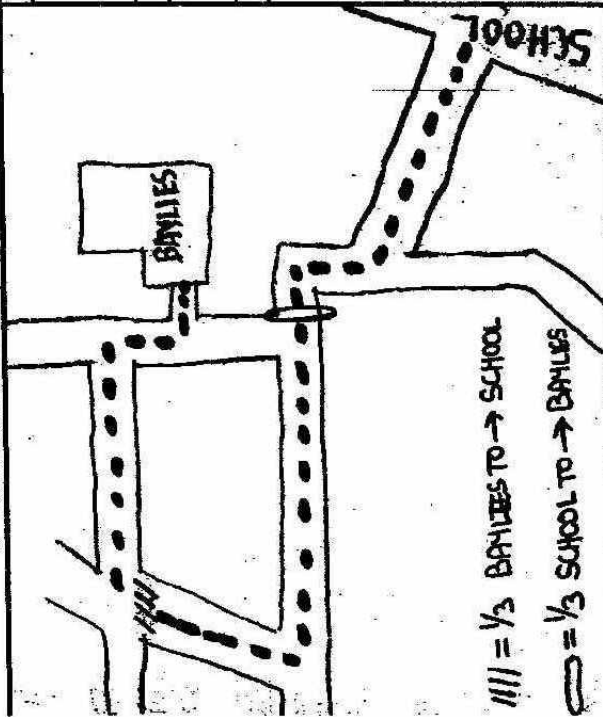

Total # of contacts*	<u>0</u>
* # of contacts should include physical interventions to avoid contact	
Total # of device activations	<u>25</u>

(ALL)

TOTAL # OF SOLID LIGHT/SOUND ACTIVATIONS: 2

Please indicate the direction of travel on the map.

Comments: decreased volume of beeping - near constant beeping in
pitigula

Please note if a specific source of motivation was used during evaluation. For example, if there is a person or object that the student is trying to reach or avoid.

Wheelchair Skills Evaluation Form

Post-evaluation
with device
without device

Evaluator name: Gray
Student name: [Redacted]

Date: 10/1/04
Circle one: AM or PM

Wheelchair Gear Drive/Speed: 4

Map Legend: X - Contact Point*
O - Activation of Device

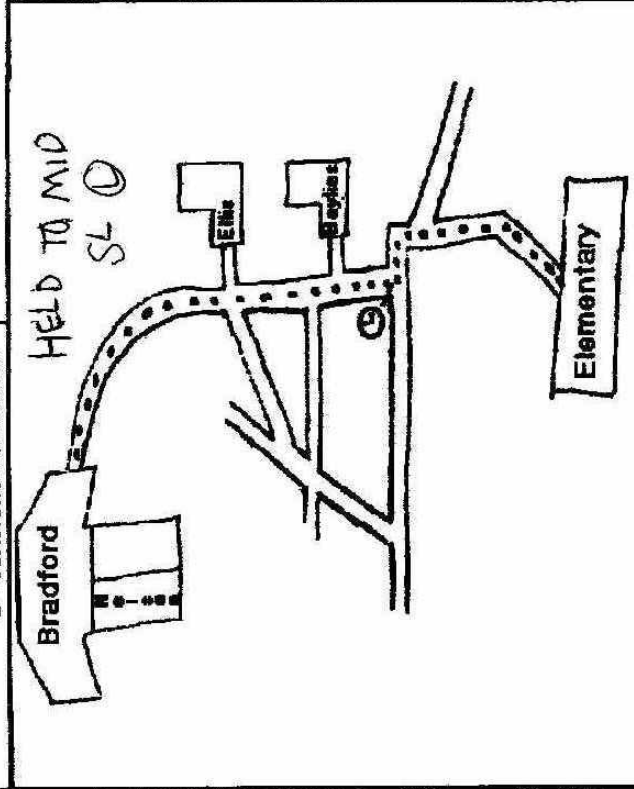

Time of start	1:19
Time of midway point	1:47
Time of finish	2:46

Total # of contacts*

* # of contacts should include physical interventions to avoid contact
In the case of an intervention, please describe the event here:

Total # of device activations

CONSTANT ACTIVATIONS:

PLEASE INDICATE THE DIRECTION OF TRAVEL ON THE MAP.

Comments:

Please note if a specific source of motivation was used during evaluation. For example, if there is a person or object that the

Wheelchair Skills Evaluation Form

Post-evaluation with device without device

Evaluator name: Geoff Reinhold Date: 10.1.04
 Student name: [redacted] Circle one: AM or PM

Wheelchair Gear/Drive/Speed: 4

	Clock Time	WATPSED TIME
Time of start	11:01:00	→ 0:00
Time of midway point	11:02:42	→ 1:42
Time of finish	11:03:47	→ 2:47

Map Legend: X - Contact Point*
 O - Activation of Device

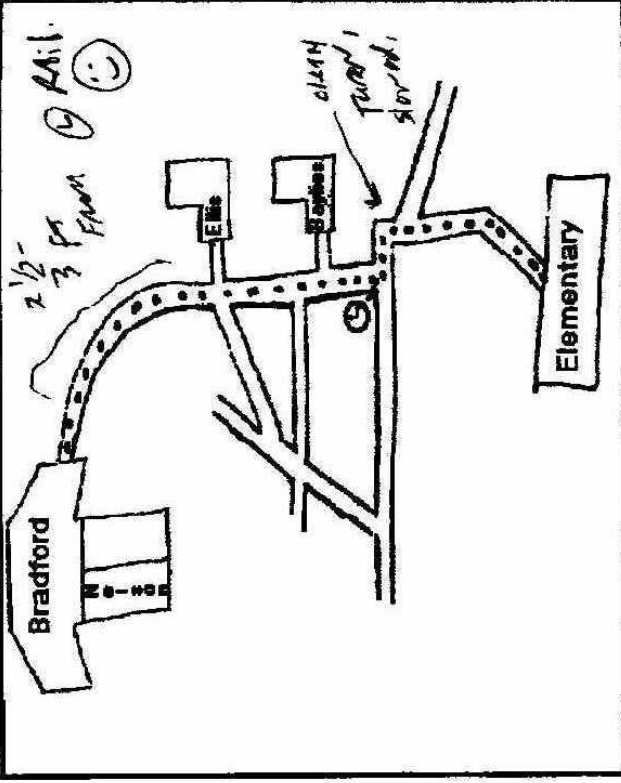

Total # of contacts* 0

* # of contacts should include physical interventions to avoid contact
 In the case of an intervention, please describe the event here:

Total # of device activations

PLEASE INDICATE THE DIRECTION OF TRAVEL ON THE MAP.

Comments:

Please note if a specific source of motivation was used during evaluation. For example, if there is a person or object that the student is trying to reach or avoid

Wheelchair Skills Evaluation Form

Post-evaluation
with device
without device

Evaluator name: Gary
Student name: [REDACTED]
Date: 10/1/07
Circle one: AM or PM

Wheelchair Gear Drive/Speed: 4

Map Legend: X - Contact Point*
O - Activation of Device

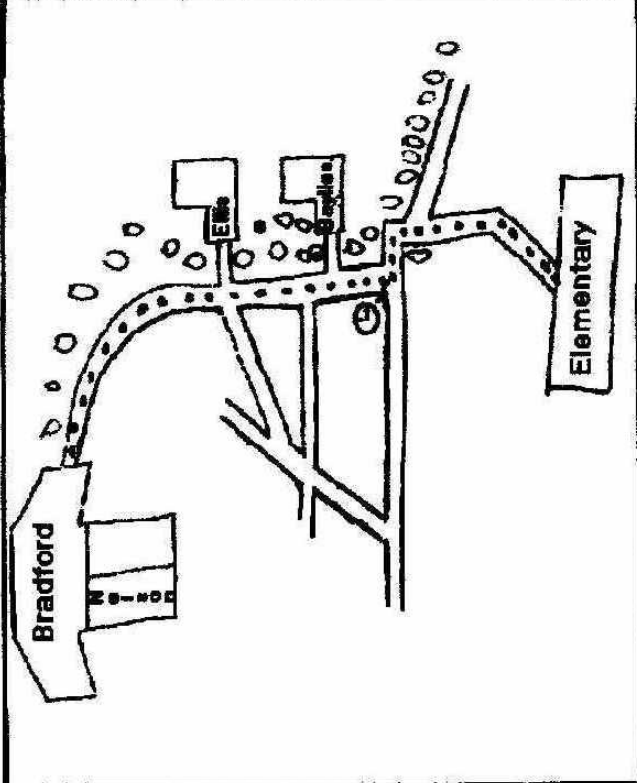

Time of start	<input type="radio"/>
Time of midway point	2:47
Time of finish	3:55

Total # of contacts*

* # of contacts should include physical interventions to avoid contact
In the case of an intervention, please describe the event here:

Total # of device activations

CONSTANT ACTIVATIONS

PLEASE INDICATE THE DIRECTION OF TRAVEL ON THE MAP.

Comments:

Please note if a specific source of motivation was used during evaluation. For example, if there is a person or object that the

Wheelchair Skills Evaluation Form

Post-evaluation with device without device

Date: 10.1.04
Circle one: AM or PM

Evaluator name: Griff
Student name: [Redacted]

Wheelchair Gear Drive/Speed: 4 NO T/T

Map Legend: X - Contact Point*
O - Activation of Device

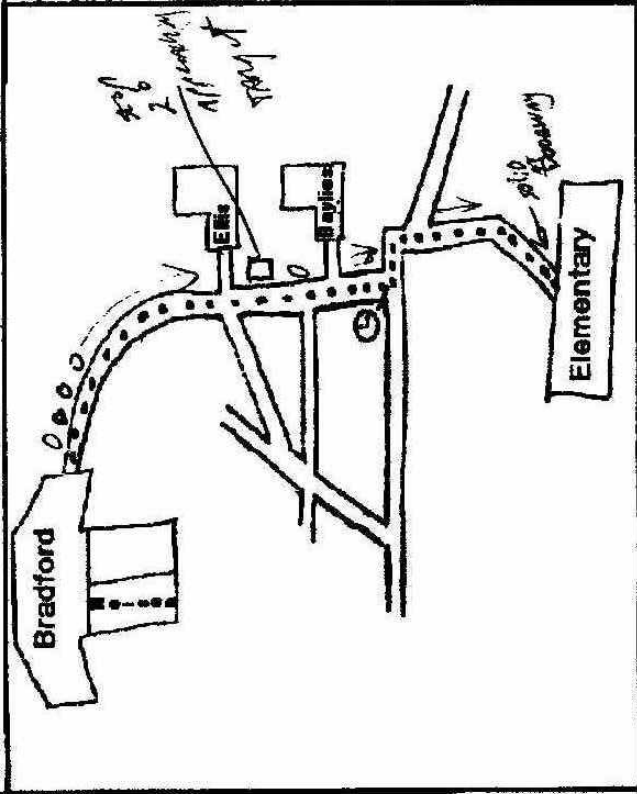

Time of start	11:18:15
Time of midway point	
Time of finish	11:20:16

Total # of contacts* 0

* # of contacts should include physical interventions to avoid contact
In the case of an intervention, please describe the event here:

Total # of device activations

PLEASE INDICATE THE DIRECTION OF TRAVEL ON THE MAP.

Comments: - STUDENT/STAFF MEMBER APPROACHED FROM FRONT.
stopped & waited for them to pass.
SHE ALSO STOPPED FREQUENTLY AFTER SUCCESSFUL ACTIVATION (estimate 10-15 times)

Please note if a specific source of motivation was used during evaluation. For example, if there is a person or object that the

Pre-evaluation without device

Wheelchair Skills Evaluation Form

Evaluator name: [REDACTED] Date: 12:15

Student name: GARY Circle one: AM or **PM**

Wheelchair Gear Drive/Speed: 3

Time of start	<u>0</u>
Time of midway point	<u>153</u>
Time of finish	<u>323</u>

Total # of contacts*

* # of contacts should include physical interventions to avoid contact
In the case of an intervention, please describe the event here:

Map Legend: X - Contact Point*

PLEASE INDICATE THE DIRECTION OF TRAVEL ON THE MAP.

Comments:

Please note if a specific source of motivation was used during evaluation. For example, if there is a person or object that the student is trained to reach or avoid

Run #2

Wheelchair Skills Evaluation Form

Pre-evaluation without device

Evaluator name: Geoff
Student name: [Redacted]

Date: 10/1/04
Circle one: AM or PM

Map Legend: X - Contact Point*

Wheelchair Gear Drive/Speed: 3

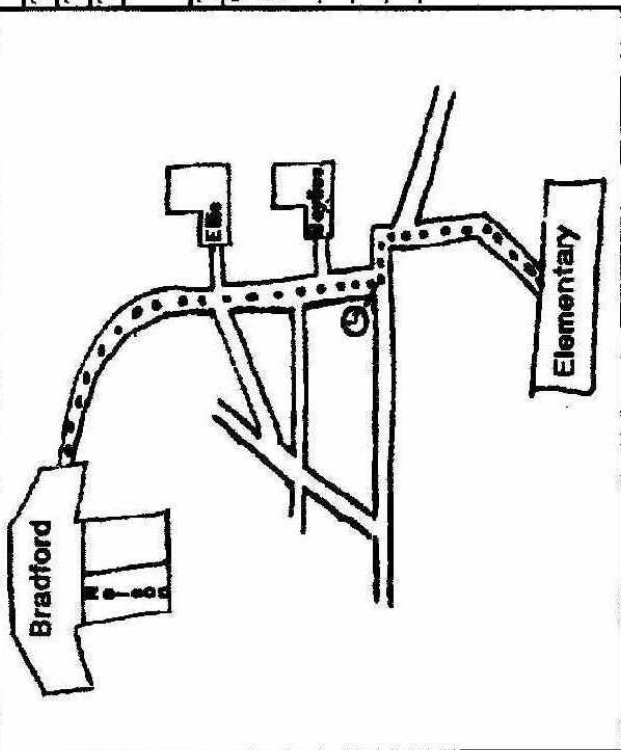

Time of start	12:19:10
Time of midway point	12:21:15
Time of finish	12:22:34

Total # of contacts* 0

* # of contacts should include physical interventions to avoid contact in the case of an intervention, please describe the event here:

PLEASE INDICATE THE DIRECTION OF TRAVEL ON THE MAP.

Comments: "sarcasm I'm doing this in my hand, and I'll suddenly
I may not be, but that's me."

Please note if a specific source of motivation was used during evaluation. For example, if there is a person or object that the student is trying to reach or avoid

- 1/10
- 2/10
- 3/10
- 4/10
- 5/10
- 6/10
- 7/10
- 8/10
- 9/10
- 10/10

Wheelchair Skills Evaluation Form

Evaluator name: Bill Brady

Date: 10/2/01

Circle one: AM or PM

REMEMBER TO AVOID VERBAL CUES AFTER THE FIRST 1/3 OF THE PATH

Wheelchair Gear Drive/Speed: 3

Map Legend: X - Contact Point*
O - Activation of Device

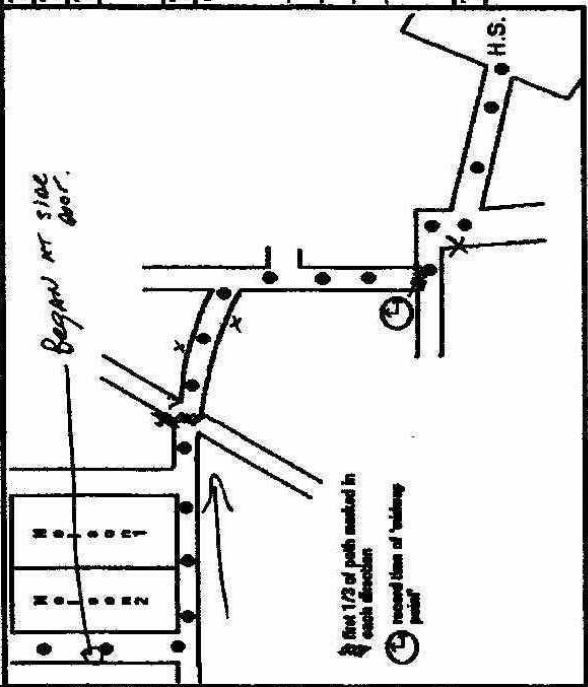

Time of start	1:00
Time of midway point	1:07 Approx
Time of finish	1:11 Approx

Total # of contacts* 0

* # of contacts should include physical interventions to avoid contact
In the case of an intervention, please describe the event here:

Total # of device activations 4

PLEASE INDICATE THE DIRECTION OF TRAVEL ON THE MAP.

Comments: Seemed to contact direction on X2 when activation occurred.
I even ? why other 2 activations occurred.

Please note if a specific source of motivation was used during evaluation. For example, if there is a person or object that the student is trying to reach or avoid.

- 1/10
- 2/10
- 3/10
- 4/10
- 5/10
- 6/10
- 7/10
- 8/10
- 9/10
- 10/10

Evaluator name: BRADY
 Student name: [REDACTED]
 Date: 10/23/04
 Circle one: AM or PM

REMEMBER TO AVOID VERBAL CUES AFTER THE FIRST 1/3 OF THE PATH

Wheelchair Gear Drive/Speed: 3

Time of start	<u>9:27</u>
Time of midway point	<u>9:29</u>
Time of finish	<u>9:33 (1.30secs)</u>

Total # of contacts* 0

* # of contacts should include physical interventions to avoid contact
 In the case of an intervention, please describe the event here:

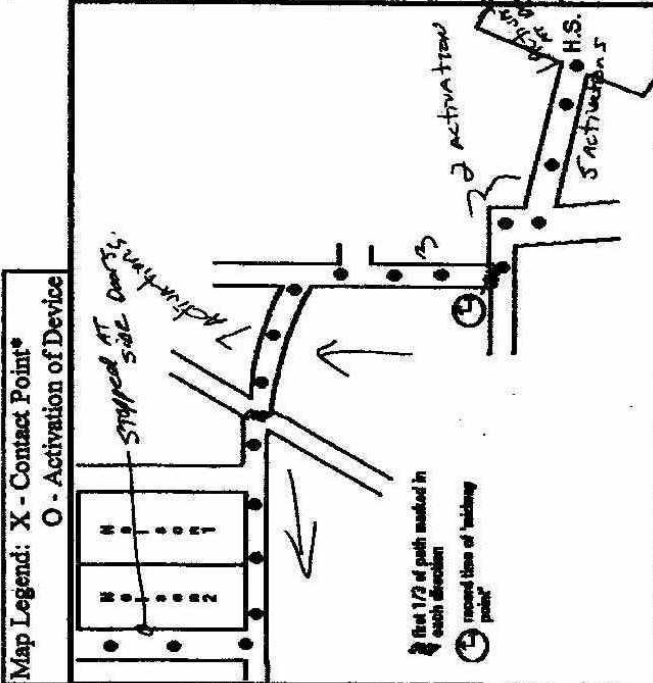

Total # of device activations 18

PLEASE INDICATE THE DIRECTION OF TRAVEL ON THE MAP.

Comments: Generally corrected a signal activation.
Most occurred to left side.
It became very frustrated; repeat activations/inconsistency.

Please note if a specific source of motivation was used during evaluation. For example, if there is a person or object that the student is trying to reach or avoid.

Evaluator name: BRADY

Student name: [REDACTED]

Date: 10/26/04

Circle one: AM or PM PM

REMEMBER TO AVOID VERBAL CUES AFTER THE FIRST 1/3 OF THE PATH

Map Legend: X - Contact Point*

O - Activation of Device

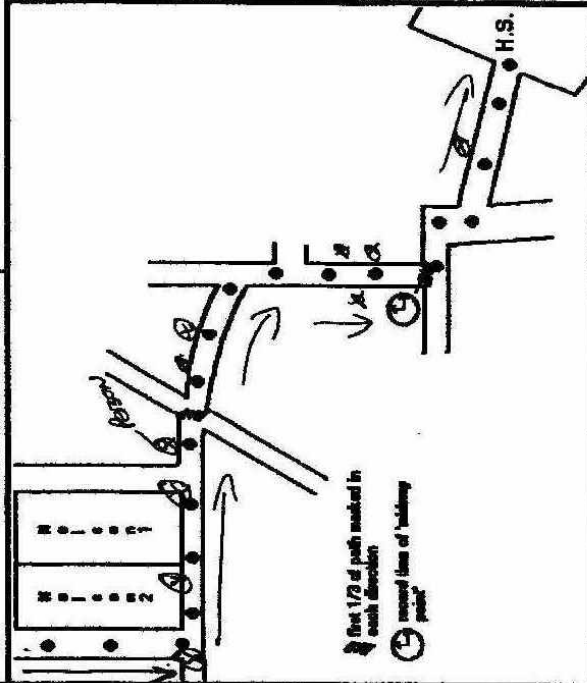

Wheelchair Gear Drive/Speed: _____

Time of start	1:21
Time of midway point	1:36
Time of finish	1:58

Total # of contacts* 0

* # of contacts should include physical interventions to avoid contact in the case of an intervention, please describe the event here:

Total # of device activations 0

PLEASE INDICATE THE DIRECTION OF TRAVEL ON THE MAP

Comments: FRUSTRATION NOTED. CORRECTED MOST OF TIME. "Why is it going off?"

Please note if a specific source of motivation was used during evaluation. For example, if there is a person or object that the student is trying to reach or avoid.

Wheelchair Skills Evaluation Form

Post-evaluation
with device
without device

Evaluator name: GARY
Student name: [REDACTED]
Date: 10/22/04
Circle one: AM or PM

Wheelchair Gear Drive/Speed: 3

Map Legend: X - Contact Point*
O - Activation of Device

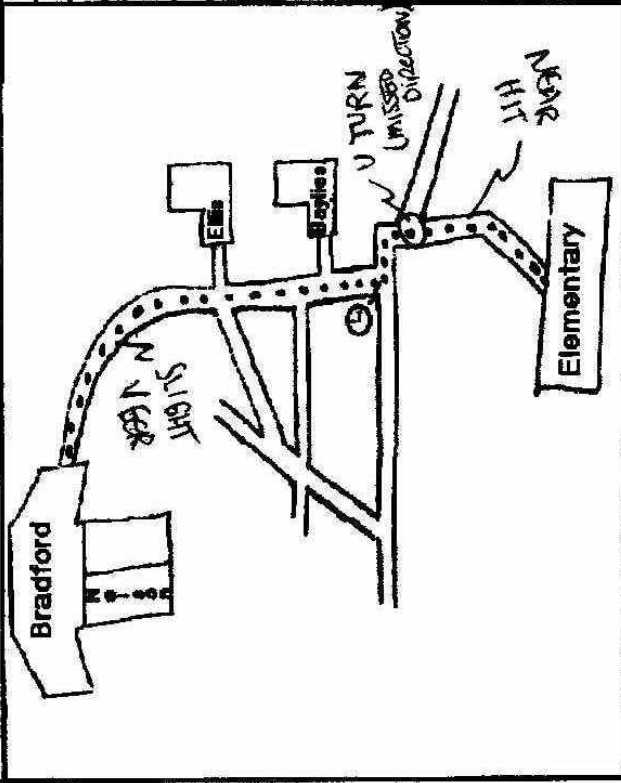

Time of start	<input type="radio"/>
Time of midway point	3:09
Time of finish	3:41

Total # of contacts*

* # of contacts should include physical interventions to avoid contact
In the case of an intervention, please describe the event here:

Total # of device activations

PLEASE INDICATE THE DIRECTION OF TRAVEL ON THE MAP.

Comments:

Please note if a specific source of motivation was used during evaluation. For example, if there is a person or object that the student is trying to reach or avoid

Wheechair Skills Evaluation Form

Post-evaluation with device without device

Evaluator name: Scott Reinhold
 Student name: [redacted]
 Date: 10/29/04
 Circle one: AM or PM

Wheechair Gear Drive/Speed: 3

Map Legend: X - Contact Point*
 O - Activation of Device

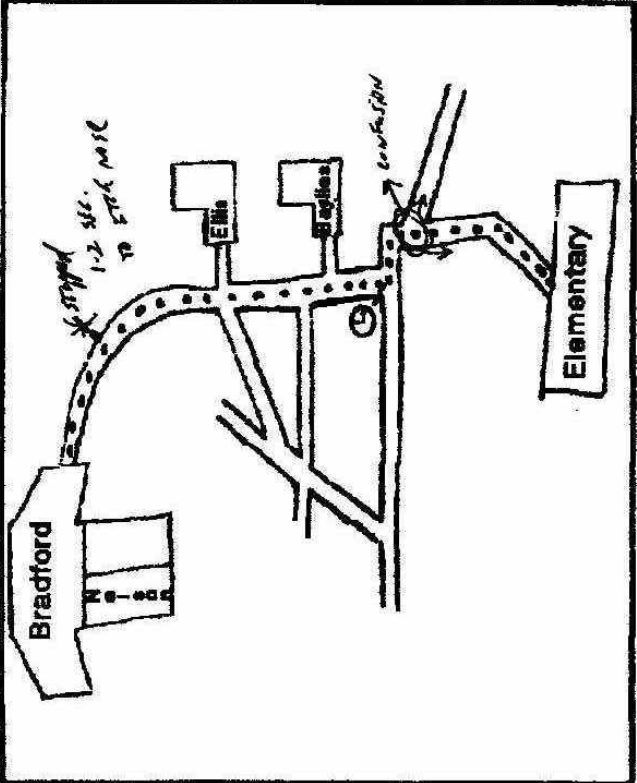

Time of start	10:44:30
Time of midway point	10:46:30
Time of finish	10:48:00

Total # of contacts* 0

* # of contacts should include physical interventions to avoid contact
 In the case of an intervention, please describe the event here:

Total # of device activations

PLEASE INDICATE THE DIRECTION OF TRAVEL ON THE MAP.

Comments: One contact at gas Peter. A.S. + ELEMENT. No hand signals received. Delay approx 5 sec.
& repeatedly stopped to read dial. (1/2-2 sec.)

Please note if a specific source of motivation was used during evaluation. For example, if there is a person or object that the student is training to reach or avoid

Wheelchair Skills Evaluation Form

Post-evaluation
with device ●
without device ○

Evaluator name: Sally
Student name: [Redacted]

Date: 10/27/04
Circle one: AM or PM

Wheelchair Gear Drive/Speed: 3

Map Legend: X - Contact Point*
O - Activation of Device

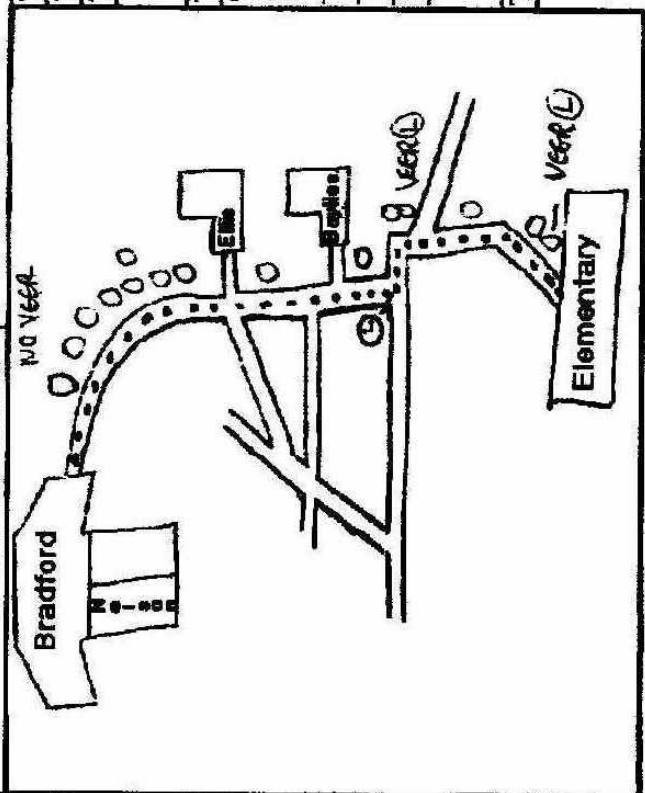

Time of start	0
Time of midway point	2:46
Time of finish	4:24

Total # of contacts*

* # of contacts should include physical interventions to avoid contact
In the case of an intervention, please describe the event here:

Total # of device activations

PLEASE INDICATE THE DIRECTION OF TRAVEL ON THE MAP.

Comments:

Please note if a specific source of motivation was used during evaluation. For example, if there is a person or object that the student is trained to reach or avoid.

Wheelchair Skills Evaluation Form

Post-evaluation
with device
without device

Evaluator name: Geoff Reinhold
Student name: [Redacted]

Date: 10/29/94
Circle one: AM or PM

Wheelchair Gear Drive/Speed: 3

Map Legend: X - Contact Point*
O - Activation of Device

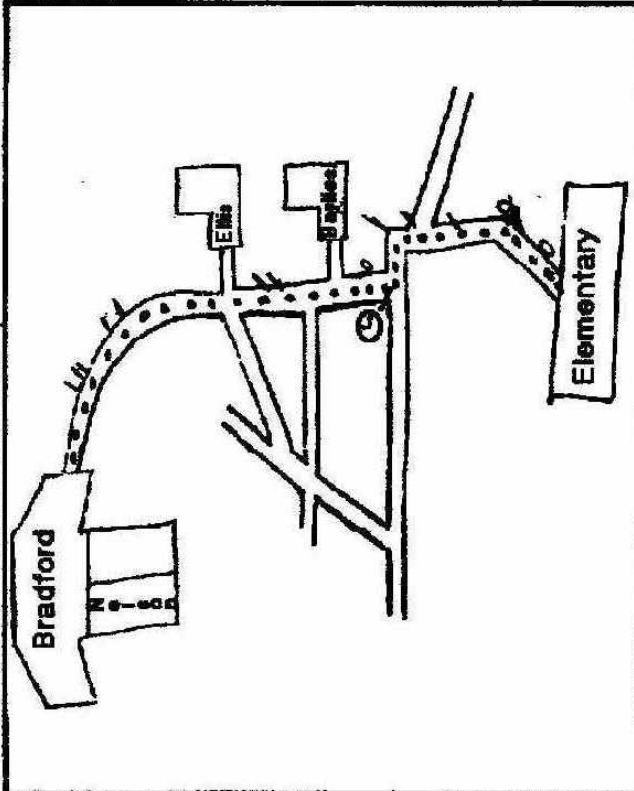

Time of start	10:58:45
Time of midway point	1:01:20
Time of finish	1:02:12

Total # of contacts*
* # of contacts should include physical interventions to avoid contact
In the case of an intervention, please describe the event here:

Total # of device activations

PLEASE INDICATE THE DIRECTION OF TRAVEL ON THE MAP.

Comments: 3 solid turns when [Redacted] was very close to wall (less than 8 inches)
several activations - seemingly lot of contact causing people
[Redacted] unable to drive past 1st left side for most of the trip
(Floor 14 noisy in EMD)

Please note if a specific source of motivation was used during evaluation. For example, if there is a person or object that the

Wheelchair Skills Evaluation Form

Evaluator name: W. M. M. Date: 10/21/08 Pre-evaluation without device

Student name: [REDACTED] Circle one: AM or PM

Wheelchair Gear Drive/Speed: 1

Time of start	000
Time of midway point	1:50
Time of finish	13:15

Total # of contacts*

* # of contacts should include physical interventions to avoid contact
 In the case of an intervention, please describe the event here:

Map Legend: X - Contact Point*

PLEASE INDICATE THE DIRECTION OF TRAVEL ON THE MAP.

Comments:

Please note if a specific source of motivation was used during evaluation. For example, if there is a person or object that the student is trying to reach or avoid.

Wheelchair Skills Evaluation Form

Pre-evaluation without device

Evaluator name: Geoff Reynolds
 Student name: [Redacted]
 Date: 10/29/09
 Circle one: AM or PM

Wheelchair Gear Drive/Speed: 1

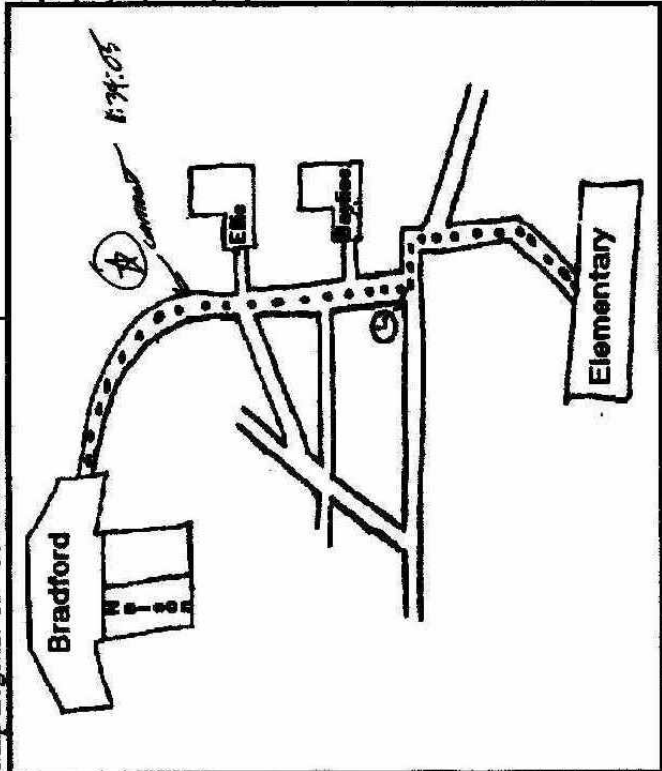

Time of start	11:31:15
Time of midway point	11:39:00
Time of finish	11:44:10

Stopped @ 11:41:30 → 11:42:10
*had to rest my back
my mind wasn't in it
I'm tired"

Total # of contacts* 1

* # of contacts should include physical interventions to avoid contact
 In the case of an intervention, please describe the event here:

Touched Rail, had to stop to get away
Very slowly

PLEASE INDICATE THE DIRECTION OF TRAVEL ON THE MAP.

Comments: _____

Please note if a specific source of motivation was used during evaluation. For example, if there is a person or object that the student is trying to reach or avoid.

Wheelchair Skills Evaluation Form

Please check one: Training Session

1/10	<input type="radio"/>
2/10	<input type="radio"/>
3/10	<input type="radio"/>
4/10	<input type="radio"/>
5/10	<input type="radio"/>
6/10	<input type="radio"/>
7/10	<input type="radio"/>
8/10	<input type="radio"/>
9/10	<input type="radio"/>
10/10	<input type="radio"/>

Evaluator name: John
 Student name: [Redacted]
 Date: 11/7/04
 Circle one: AM or PM AM

REMEMBER TO AVOID VERBAL CUES AFTER THE FIRST 1/3 OF THE PATH

Map Legend: X - Contact Point*
 O - Activation of Device

Time of start	<u>0</u>
Time of midway point	<u>156</u>
Time of finish	<u>5:45</u>

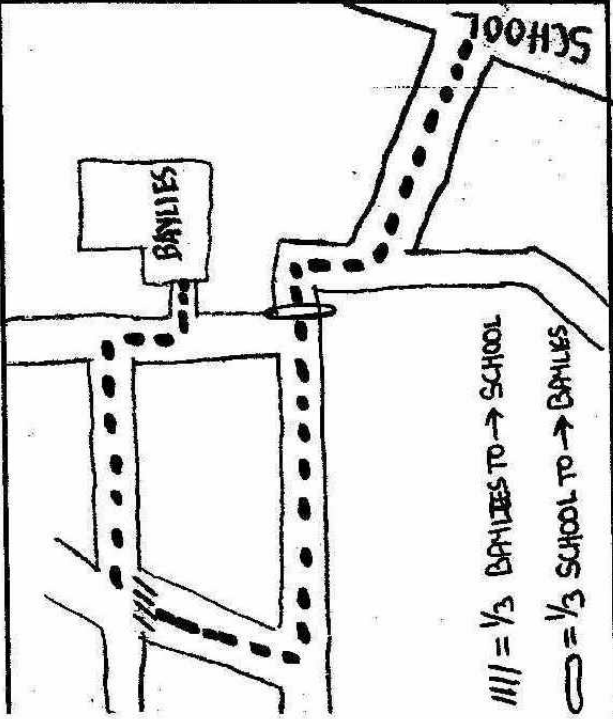

Total # of contacts* 0
 * # of contacts should include physical interventions to avoid contact

Total # of device activations 6
 (ALL)

TOTAL # OF SOLID LIGHT/SOUND ACTIVATIONS: 0

Please indicate the direction of travel on the map.

Comments: Did not beep at all appropriate times

Please note if a specific source of motivation was used during evaluation. For example, if there is a person or object that the student is trying to reach or avoid.

Wheelchair Skills Evaluation Form

Please check one: Training Session
 1/10 2/10 3/10 4/10 5/10 6/10 7/10 8/10 9/10 10/10

Evaluator name: Tom
 Student name: [Redacted]
 Date: _____
 Circle one: AM or PM

REMEMBER TO AVOID VERBAL CUES AFTER THE FIRST 1/3 OF THE PATH

Map Legend: X - Contact Point*
 O - Activation of Device

Time of start	
Time of midway point	
Time of finish	7

Total # of contacts* 0
 * # of contacts should include physical interventions to avoid contact

Total # of device activations 5
 (ALL)

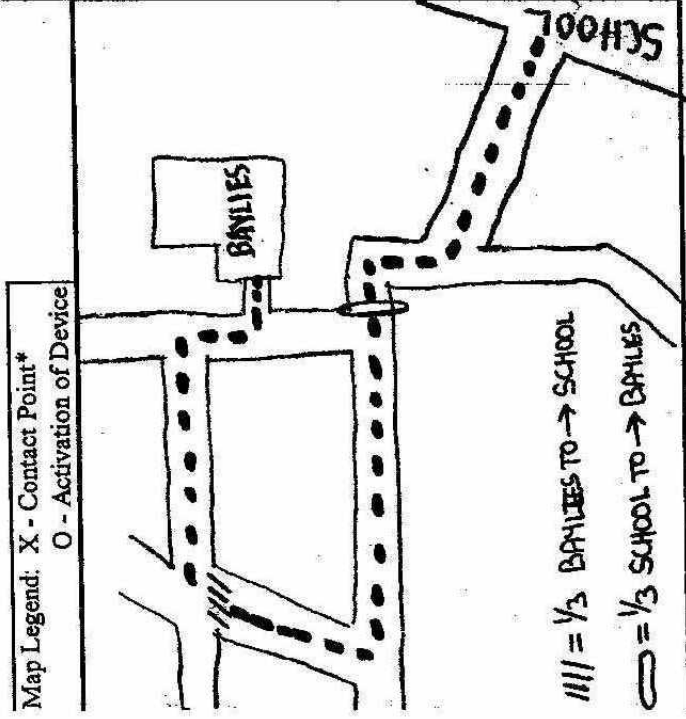

/// = 1/3 BATHS TO → SCHOOL
 — = 1/3 SCHOOL TO → BATHS

TOTAL # OF SOLID LIGHT/SOUND ACTIVATIONS: 1

Please indicate the direction of travel on the map.

Comments: _____

Please note if a specific source of motivation was used during evaluation. For example, if there is a person or object that the student is trying to reach or avoid.

Wheelchair Skills Evaluation Form

Please check one: Training Session
 1/10 2/10 3/10 4/10 5/10 6/10 7/10 8/10 9/10 10/10

Evaluator name: Falk
 Student name: [Redacted]
 Date: 12/9/04
 Circle one: AM or PM

REMEMBER TO AVOID VERBAL CUES AFTER THE FIRST 1/3 OF THE PATH

Map Legend: X - Contact Point*
 O - Activation of Device

Time of start	<u>9</u>
Time of midway point	<u>3:45</u>
Time of finish	<u>5:30</u>

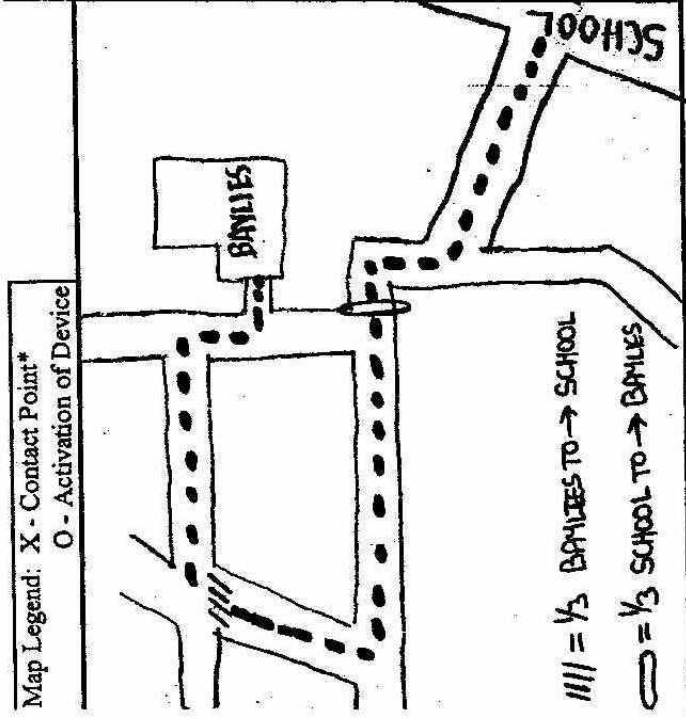

Total # of contacts* 0
 * # of contacts should include physical interventions to avoid contact

Total # of device activations 7
 (ALL)

TOTAL # OF SOLID LIGHT/SOUND ACTIVATIONS: 1

||| = 1/3 BAYLIES TO → SCHOOL
 --- = 1/3 SCHOOL TO → BAYLIES

Please indicate the direction of travel on the map.

Comments: 1 X Scored at extended count
Several times did not sand appropriately

Please note if a specific source of motivation was used during evaluation. For example, if there is a person or object that the student is trying to reach or avoid.

Wheelchair Skills Evaluation Form

Please check one: Training Session

- 1/10
- 2/10
- 3/10
- 4/10
- 5/10
- 6/10
- 7/10
- 8/10
- 9/10
- 10/10

Evaluator name: Faith
 Student name: [REDACTED]
 Date: 12/16/04
 Circle one: AM or **PM**

REMEMBER TO AVOID VERBAL CUES AFTER THE FIRST 1/3 OF THE PATH

Map Legend: X - Contact Point*
 O - Activation of Device

Time of start	0
Time of midway point	2:07
Time of finish	3:55

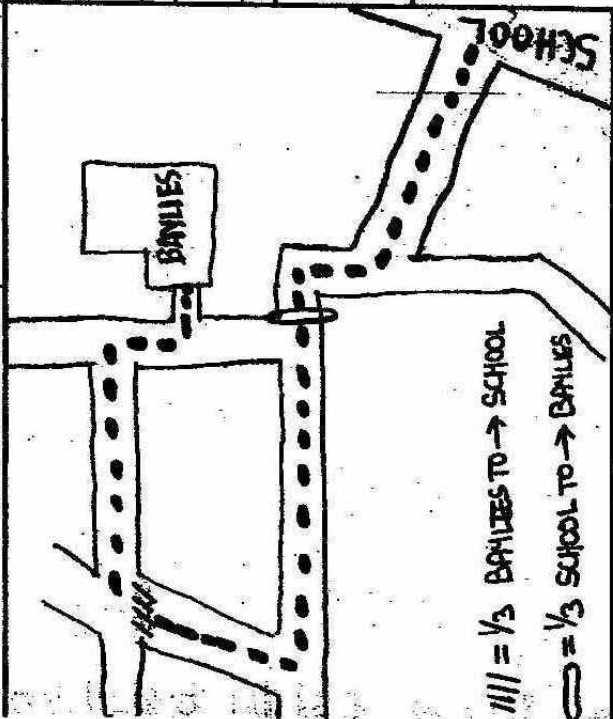

Total # of contacts* 4
 * # of contacts should include physical interventions to avoid contact
 Total # of device activations 4
 (ALL)

TOTAL # OF SOLID LIGHT/SOUND ACTIVATIONS: 3

/// = 1/3 BAYLIES TO → SCHOOL
 — = 1/3 SCHOOL TO → BAYLIES

Please indicate the direction of travel on the map.

Comments: At first seemed very sensitive. Then it seemed more appropriate

Please note if a specific source of motivation was used during evaluation. For example, if there is a person or object that the student is trying to reach or avoid.

Wheelchair Skills Evaluation Form

Post-evaluation
with device
without device

Evaluator name: GARY RABINSON
Student name: [REDACTED]

Date: 12/17/04
Circle one: (AM) or PM

Wheelchair Gear Drive/Speed: _____

Time of start	<u>0</u>
Time of midway point	<u>6:18</u>
Time of finish	<u>10:42</u>

Total # of contacts* _____

* # of contacts should include physical interventions to avoid contact
In the case of an intervention, please describe the event here:

Total # of device activations _____

Map Legend: X - Contact Point*
O - Activation of Device

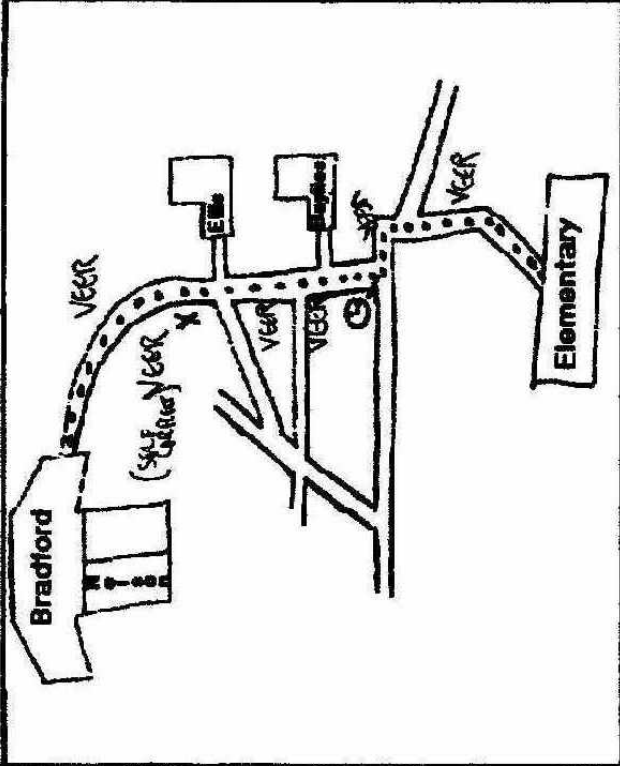

PLEASE INDICATE THE DIRECTION OF TRAVEL ON THE MAP.

Comments: _____

Please note if a specific source of motivation was used during evaluation. For example, if there is a person or object that the student is trying to reach or avoid.

William ...

Wheelchair Skills Evaluation Form

Evaluator name: Geoff Kinchell
Student name: [Redacted]

Date: 12/17/04
Circle one: AM of PM

Post-evaluation with device
without device

Wheelchair Gear Drive/Speed: 0

Map Legend: X - Contact Point*
O - Activation of Device

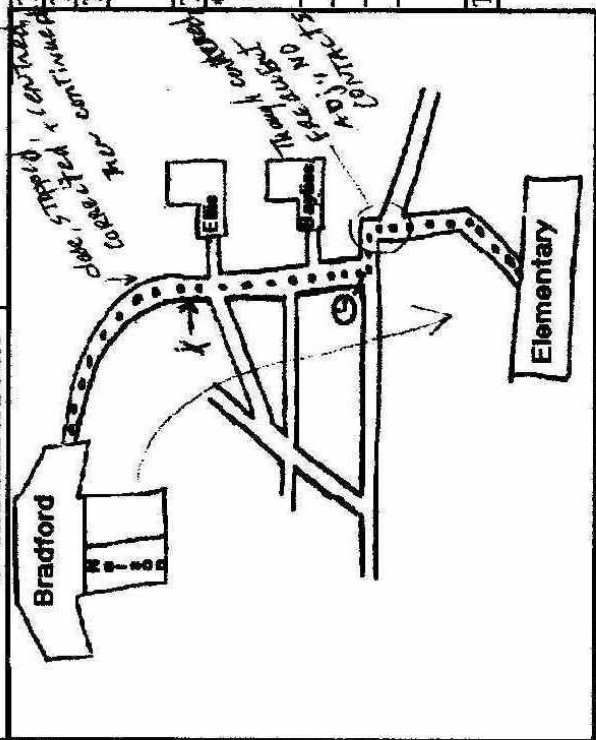

Time of start	
Time of midway point	6:13
Time of finish	10:33

Total # of contacts* 1

* # of contacts should include physical interventions to avoid contact
In the case of an intervention, please describe the event here:

Total # of device activations 1

PLEASE INDICATE THE DIRECTION OF TRAVEL ON THE MAP.

Comments:

ONE contact w/ railing,

Please note if a specific source of motivation was used during evaluation. For example, if there is a person or object that the student is trying to reach or avoid.

Wheelchair Skills Evaluation Form

Post-evaluation with device ● without device ○

Evaluator name: GARY BARTON
 Student name: [REDACTED]
 Date: 12/17/04
 Circle one: AM or PM

Wheelchair Gear Drive/Speed: 1

Map Legend: X - Contact Point*
 O - Activation of Device

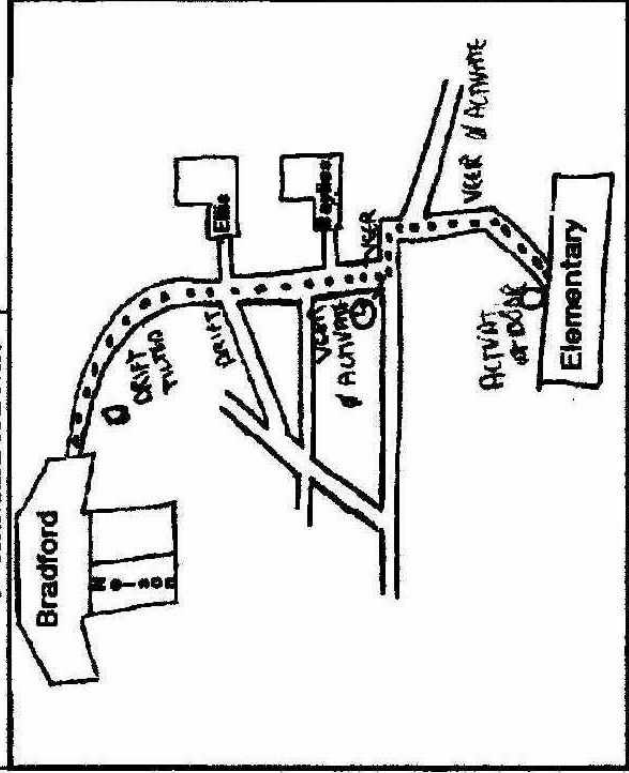

Time of start	0
Time of midway point	7:10
Time of finish	7:45

Total # of contacts*

* # of contacts should include physical interventions to avoid contact in the case of an intervention, please describe the event here:

Total # of device activations

PLEASE INDICATE THE DIRECTION OF TRAVEL ON THE MAP.

Comments: Didn't use manual when user of Post of device. Movement off course - self correction was less than 1/2 in. By small distance to back several quarters for this post and then still.

Please note if a specific source of motivation was used during evaluation. For example, if there is a person or object that the student is trying to reach or avoid.

Wheelchair Skills Evaluation Form

Post-evaluation
with device
without device

Evaluator name: Griff
Student name: [Redacted]

Date: 12/17/04
Circle one: AM or PM

Wheelchair Gear Drive/Speed: 1

Map Legend: X - Contact Point*
O - Activation of Device

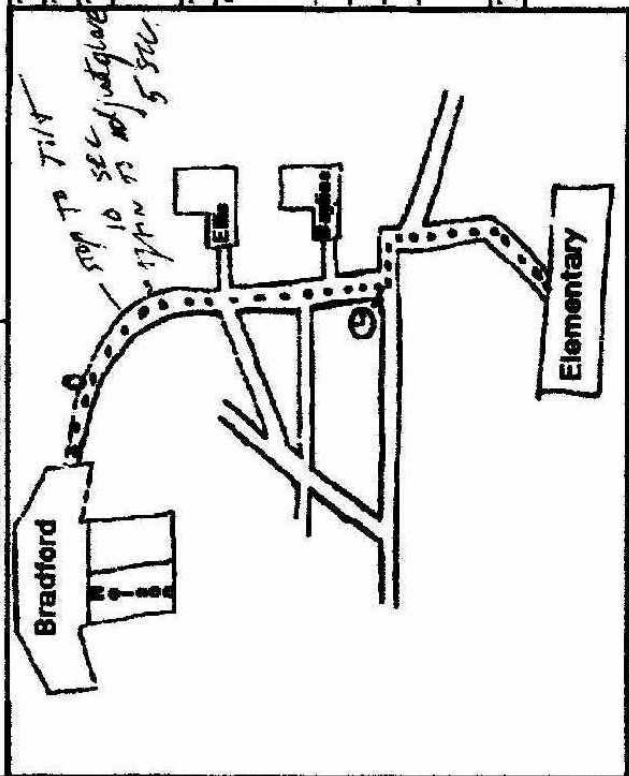

Time of start	
Time of midway point	7:09
Time of finish	11:33

7:09
11:33

Total # of contacts* 0

* # of contacts should include physical interventions to avoid contact
In the case of an intervention, please describe the event here:

Total # of device activations 1

PLEASE INDICATE THE DIRECTION OF TRAVEL ON THE MAP.

Comments: MORE CENTERED ON PATH - MADE STOPS TO ADJUST TILT/BLADES
DUO TO WIND & COLD.
SEEMED MORE CONTROLLED.

Please note if a specific source of motivation was used during evaluation. For example, if there is a person or object that the student is trying to reach or avoid.

References

“EM-PV Reverse Sensing System” 2005. Echomaster Obstacle Avoidance Systems. 6 Apr. 2004 <<http://www.echomaster.com/products.htm>>

“Hand Guide from Guideline” 2005. Guideline Technologies. 19 May 2004 <www.guideline-technologies.com>

Janeschild, Miranda. “Early Power Mobility: Evaluation and Training Guidelines”. Pediatric Powered Mobility: Developmental Perspectives, Technical Issues, Clinical Approaches. Ed. Jan Furumasu. Arlington, VA: RESNA, 1997. 48-57.

Kangas, Karen. “Clinical Assessment and Training Strategies for the Child’s Mastery of Independent Powered Mobility”. Pediatric Powered Mobility: Developmental Perspectives, Technical Issues, Clinical Approaches. Ed. Jan Furumasu. Arlington, VA: RESNA, 1997. 33-47.

MacPhee, A., R.L. Kirby, A. Coolen, C. Smith, D. MacLeod, Dand D. Dupuis. “Wheelchair Skills Training Program: A Randomized Clinical Trial of Wheelchair Users Undergoing Initial Rehabilitation”. Archives of Physical Medicine and Rehabilitation, 85 (2004): 41-50.

“ReverseGuard” 2005. American Road Products, Inc. 6 Apr. 2004 <<http://americanroadproductsinc.com/>>

“Rostra Obstacle Sensing System” 2002. Rostra Precision Controls, Inc. 16 Nov. 2004 <<http://www.rostra.com/rostra-obstacle.htm>>

“Sense Technologies Guardian Alert Doppler Awareness System” 2005. Sense Technologies, Inc. 7 Apr. 2004 <<http://www.sensetech.com/guardianalert.htm>>

“Sharp GP2D12 Detector Package” 2005. Acroname Easier Robotics. 16 Nov. 2004 <www.acroname.com/robotics/parts/R48-IR12.html>

Simpson, R., S. Levine, D. Bell, Y. Koren, J. Borenstein and L. Jarosi. “The NavChair Assistive Navigation System”. IEEE Transactions on Rehabilitation Engineering. 7.4 (1991): 443-451.

Simpson, R., E. LoPresti, S. Hayashi, I. Nourbakhsh and D. Miller. “The Smart Wheelchair Component System”. Journal of Rehabilitation Research and Development. 41.3B (2004): 429-442.

Tefft, D., J. Furumasu, and P. Guerrette. "Pediatric Powered Mobility: Influential Cognitive Skills". Pediatric Powered Mobility: Developmental Perspectives, Technical Issues, Clinical Approaches. Ed. Jan Furumasu. Arlington, VA: RESNA, 1997. 70-93

"Ultrasonic Reverse Sensing System" 2005. Shoreline Associates, Inc. 6 Apr. 2004
<www.childautosafety.com/catalog.0.html.0.html>