

Retainable Rack Design for Large Fabrication Parts

A Major Qualifying Project Report
Submitted to the faculty of
WORCESTER POLYTECHNIC INSTITUTE
In partial fulfillment of the requirements
For the degree of Bachelor of Science by:

Ryan Anderson

Melissa Chung

Richard Nazzaro

In collaboration with:

Shanghai University
Caterpillar Inc.
Xiao (Leo) Huang
Li (Lee) Simin Zhuang
(Jack) Yunfeng

December 9, 2011

Approved: _____

Professor Kevin Rong, Advisor



This report represents the work of three WPI undergraduate students submitted to the faculty as evidence of completion of a degree requirement. WPI routinely publishes these reports on its web site without editorial or peer review.

Abstract

This project, in collaboration with Shanghai University, established a new rack design to help transport large fabrication parts for Caterpillar Suzhou, China. This project was completed by first gathering necessary information from Caterpillar to allow for design criteria to be established. Using the design criteria, a convergent design process was followed to narrow down three initial designs to one final optimum design. The most optimum design was then validated before being offered to Caterpillar for future use.

Acknowledgements

Our team would like to thank our project sponsor Caterpillar Inc for providing us with the opportunity to work on a real world project. The project itself could not have existed without the managers and engineers at Caterpillar Inc: Paul Watts, Steven Xie and Michael Liu. They have helped us throughout the project by giving us tours of the manufacturing facility in Suzhou, necessary information relating to the current rack design, CAD models and feedback on our designs.

We would also like to recognize two professors for providing much in way of insight and guidance throughout the duration of the project, Professors Rong and Zhang. Finally we would like to acknowledge Shanghai University for acting as our host and providing accommodations during our stay in China.

Table of Contents

Abstract.....	1
Acknowledgements.....	3
List of Figures	6
List of Tables	7
1 Introduction:	8
2 Background Information	9
2.1 Company Profile.....	9
2.2 The Suzhou Company.....	9
2.3 The Motor Grader Group	10
3 Research Methodology	12
3.1 Understand the Inadequacies of the Current Design	12
3.2 Develop Alternative Designs	13
3.2.1 Determine Most Optimum Design.....	13
3.4 Validate Most Optimum Design.....	14
4 Design Considerations:	16
4.1 Design Priorities	17
5 Design Process	17
5.1 Design Phase One.....	18
5.2 Design Phase Two	22
6 Results	25
6.1 Final Rack Features	26
6.2 Final Rack Dimensions.....	28
6.3 Material Selection	30
7 Validation:	30
7.1 Safety	31
7.2 Quality:.....	32
7.3 Transportation:	34
8 Cost Analysis	35
8.1 Truck Efficiency	35
9 Conclusions and Recommendations:	36
Appendix A- Project Brief from Caterpillar	37

Appendix B- Risk when braking.....	39
Appendix C-Risk at an angled slope	40
Appendix D- Risk if Rack tips over.....	41
Appendix E- Mathcad Calculations.	42
Bibliography:	43

List of Figures

Figure 1. Caterpillar Motor Graders.....	10
Figure 2. Bolster shown on motor grader.....	10
Figure 3. Bolster resting on current rack design.....	11
Figure 4. Methodology used in the design process.....	12
Figure 5. Truck Dimensions.....	16
Figure 6. Forklift Dimensions.....	17
Figure 7. Caterpillar Design Priorities.....	17
Figure 8. Design Alternatives of Phase I.....	18
Figure 9. Isometric and Bottom View of Design Alternative 1.....	18
Figure 10. Isometric and Bottom View of Design Alternative 2.....	19
Figure 11. Isometric and Bottom View of Design Alternative 3.....	19
Figure 12. Maximum Von Mises Stresses of Design Alternatives 1,2 and 3.....	21
Figure 14. Non-foldable and Foldable Racks from design phase 2.....	22
Figure 15. Interaction between male and female parts of leg, forklift access of Rack 2 is too wide.....	25
Figure 16. Isometric View of final rack design and when it is stacked 3 level high.....	25
Figure 17. Bottom Structure of Final Rack.....	26
Figure 18. Removable Bar to prevent bolsters from falling forward and backward.....	27
Figure 19. Final Rack Design with 2 forklift access.....	27
Figure 20. Leg of rack or "hoof".....	27
Figure 21. Clearance between each bolster.....	28
Figure 22. Parts Explosion of Final Rack Design.....	28
Figure 23. Side View of Current Rack.....	32
Figure 24. Solidworks FEM analysis of rack.....	33
Figure 25. Loading of bolsters on rack.....	34
Figure 26. Using forklift to stack the racks.....	34
Figure 27. Unloading of Bolsters from rack with cranes.....	34
Figure 28. Arrangement of racks on truck.....	35

List of Tables

Table 1. Physical Dimensions of Bolster. 16

Table 2. Physical Properties of the design alternatives 1,2 and 3. 19

Table 3. Loads applied to design alternative 1,2 and 3. 20

Table 4. Data from ALGOR analyses..... 21

Table 5. Physical Dimensions of Phase 2 Rack..... 23

Table 6. FEM analysis of rack with and without plate. 24

Table 7. Physical Dimensions of Final Rack..... 25

Table 8. Rack Parts and Dimensions. 29

Table 9. Physical Properties of GB 10. 30

Table 10.Solidworks FEM results. 33

Table 11. Cost estimation of racks..... 35

1 Introduction:

Caterpillar Inc. originally Caterpillar Tractor Co. was founded in California in 1925 (Bloomberg Business Week). It is now a global company that produces and sells construction, mining equipment, diesel and natural gas engines, industrial gas turbines, and diesel-electric locomotives. Its three main operating lines include machinery, engines and financial products.

Caterpillar sold its first products in China in 1975 and then opened the first office in Beijing in 1978. Caterpillar currently owns and operates 13 production enterprises throughout China. These facilities manufacture hydraulic excavators, compactors, diesel motors, and many other products.

Suzhou industrial park was established in 2006 and was officially put into production in January of 2009. Caterpillar Suzhou Company Limited specializes in manufacturing world-class medium wheel loaders and motor grader which is sold in Eastern Asia, Russia and other foreign locations. In March of 2010 Suzhou Company Limited met LEED (Leadership in Energy and Environmental Design) gold standards.

One inherent problem that the Suzhou division of Caterpillar is facing is an inadequate transporting system for the bolster of the motor grader. The current transporting system includes a metal rack that is much like a pallet used in warehouses; it is non-stackable, dangerous, and inefficient for transportation.

The goal of this project was to focus on the design aspects of a new rack to help aid in the transportation of a bolster for the Motor Grader Group from Caterpillar's supplier to the assembly facility in Suzhou. To achieve this goal, we first began with understanding the inadequacies of the current rack design. We then developed alternative designs for a new rack that meet the needs of the customer. Following that, we developed the most optimum design based off of our alternative designs. The final goal for this project was the validation phase where we proved the effectiveness of our most optimum design.

2 Background Information

The goal of this section is to provide adequate background information to understand Caterpillar Inc. as a company. By looking at the company's profile, a better understanding of how the Motor Grader group works and how it fits in with the rest of the organization can be obtained. From here, the specific products that the Suzhou branch produces will be addressed. This chapter is concluded by addressing the specific project that is being focused on for the Motor Grader Group at the Suzhou branch.

2.1 Company Profile

Caterpillar Inc. originally Caterpillar Tractor Co. was founded in California in 1925 (Bloomberg BusinessWeek). It is now a global company that produces and sells construction and mining equipment, diesel and natural gas engines, industrial gas turbines and diesel-electric locomotives. Its three main operating lines include machinery, engines and financial products.

The company's products are sold under the brand names: "CAT", "Caterpillar", "Solar Turbines", "MaK", "Perkins", "FG Wilson", "Olympian" and "Progress Rail". The brand CAT is the biggest and most respected family products and services in the earth moving industries across the world (Caterpillar Inc, ; *Caterpillar products*.;). The company has plants all over the world and sells equipment via 3500 offices in some 180 countries (Hoovers).

Caterpillar (China) Investment Co. Ltd. was established in China in 1996 and since then the company has increased its business and business development activities in China. Thirteen production facilities have been opened and the products manufactured include: hydraulic excavators, compactors, diesel motors, crawler units, castings, driven graders, crawler dozers, wheel loaders, remanufactured engineering machinery parts, and power generators.

2.2 The Suzhou Company

This project was sponsored by Caterpillar Suzhou Company Limited which was established in Suzhou Industrial Park in 2006, and was officially put into production in 2009. Caterpillar Suzhou is a branch of Caterpillar which specializes in manufacturing world-class medium wheel loaders and motor graders for markets in Asia Pacific, Russia, CIS, Africa, Middle East and South America (Caterpillar Inc).

A wheel loader is a heavy machine which as its name indicates, loads materials such as asphalt, rocks, soil, sand, gravel and logs from one place and briefly transports the materials to a large truck. The other piece of equipment that the Suzhou Company manufactures are the motor graders which are machines with long blades used to create a flat or inclined surface. The blade is the grader and is either controlled mechanically or hydraulically. Motor graders are generally used in construction, road maintenance and sometimes even snow removal.



Figure 1. Caterpillar Motor Graders.

2.3 The Motor Grader Group

The focus of this project was on motor graders. The Motor Grader Product Group in Suzhou currently makes four different models of graders: 12K, 120K, 140K, and 160K. The major differences between these models include the engine, overall size, and blade specifications. The main parts of the motor graders are transported from the supplier to the facility in Suzhou where they are assembled.



Figure 2. Bolster shown on motor grader.

One inherent problem that the Suzhou division of Caterpillar was facing was an inadequate transportation system for the bolster of the motor grader. The current transporting system includes a metal rack that is similar to the pallet used in warehouses. Figure 2, shows the bolsters sitting on the current rack design.



Figure 3. Bolster resting on current rack design.

The specific problems of the current rack design include the following:

- Potential dangers while shipping
- Inefficient storage of fabricated parts
- Difficulties while transporting or moving

3 Research Methodology

The goal of this project was to design a rack to help aid in the transportation of a bolster for the Motor Grader Group from Caterpillar’s supplier to the facility in Suzhou. The following four goals were created in order to achieve the goals of this project:

- Understanding the inadequacies of the current rack design for the bolster
- Develop preliminary iterations that meets the need of the customer
- Determine most adequate rack design
- Validate most optimum design

These four objectives were prioritized in their sequential order. For each objective, an organized plan was made in order to come up with the most appropriate conclusions. Both qualitative and quantitative research methods were used to acquire the needed information.

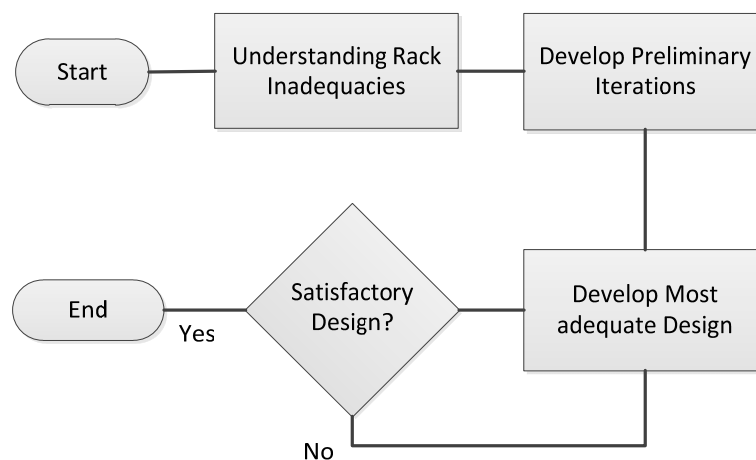

Figure 4. Methodology used in the design process.

3.1 Understand the Inadequacies of the Current Design

Understanding the current inadequacies of the current rack design was the leading objective of our project. From the project description provided by the Motor Grader Group we were able to learn that the current rack moves around during transportation which made it very dangerous. Space was also wasted in the shipping process since it is not stackable. It was essential to create a safer and more cost effective rack for the bolster; the best way to do this was by designing a new rack.

Certain specifications were needed in order to come up a new design. These specifications included: understanding safety issues, shipping information, current material used, handling and

loading procedures. In order to obtain this information, qualitative key informant interviews with our liaisons from the Caterpillar Company were conducted. This was an effective way of gathering data since the liaisons work directly with the bolster and they are familiar with the way the rack is shipped and handled. A plant tour was also needed for questions that arose in understanding the problems with the current rack.

Understanding the current inadequacies was prioritized as the first objective because without the analysis part, no enhancements could be made. In addition to analyzing the current rack used in the Motor Grader Group, other racks used by the Caterpillar Company were explored.

3.2 Develop Alternative Designs

Developing alternative designs which meet the needs for Caterpillar was prioritized as the second objective. Designing a number of different racks was the best way to narrow down the best choice for the project. All current rack inadequacies needed to be taken into consideration when designing different racks.

A plant tour and key informant interviews were the first steps in brainstorming different designs. Research of different racks currently used in industry was able help in designing the best rack for the Bolster. By investigating other racks used in industry, an insight was gained about how to create the most optimal design. Learning from what others have done either in the past or currently use in the present also improved the chances of designing something that would not only meet expectations but surpass them.

Being able to develop a variety of alternative designs helped lead to creating one final rack design to present to the Motor Grader Group. But without a full understanding of the current problems the rack is having now, a new enhanced design would have been unachievable. Researching racks currently used on the market today would only help to improve preliminary designs.

3.2.1 Determine Most Optimum Design

Conducting interviews with Caterpillar liaisons were important after preliminary designs were developed. Insight was gained by discussing preliminary designs with the engineers of the Motor Grader Group.

In order to conduct interviews with liaisons from Caterpillar a series of questions was made which were discussed per presented design. A series of set questions was formulated to ensure that all iterations were being viewed, inspected, and reviewed the same way. If a set of formulated questions wasn't used, bias could have played a factor instead of true structural soundness. From these conducted interviews insight into narrowing down design for more in-depth analysis was hoped to be accomplished.

Not only would interviews help narrow down a plethora of alternative designs, but it also helped to ensure that our project was still headed toward the common goal. Design considerations provided by The Motor Grader Group during the interviews helped to funnel down our designs as part of a convergent design process which helped create the final rack the CAT was able to approve.

3.4 Validate Most Optimum Design

Demonstrating the validity of the final design was the very last step to be completed and was equally important as the other steps. This step proved the feasibility and effectiveness of the design. Proving the design was conducted by four means that ranged from stress analysis to statistical analysis, but followed hierarchy of design priorities given by caterpillar.

The first step in proving the validity of our final design was to make sure that the rack was safe for every foreseeable situation. To prove Safety three possible situations were determined relating to sliding of the bolster on the rack, sliding of the bolster on the rack while the rack was inclined, and finally tipping of the rack depending on rack orientation and varying center points of gyration.

The second proving point was quality of the rack. We defined quality as a rack that could adequately support the loads it would see in operation without causing excessive stress, strain, or deformation values. To aid in determining of quality phase, we used the Finite Element Method invested in commercially available software, mainly SolidWorks simulation, ANSYS, and Autodesk's Algor. The main results that were looked within each analysis were Von Mises Stress and strain, and maximum deflection. These values were then compared to limits of the selected material, such as the yield strength for steel.

The third proving point was Transportation. In this step we sought out opportunities to visually show how our rack could easily be transported, and how bolsters could easily be loaded on to and off the rack. We also took consideration to the orientation of the rack based on results from the safety proving step. SolidWorks animation was utilized to allow for moving pictures to be generated.

The final proving step was validation the cost of this particular rack, Caterpillar's last and of less importance priority. To do this, we developed cost criteria based on manufacturability, shipment, and labor. We were able to determine an estimated cost for the final rack design based on all three of the prior inputs.

The final proving step was validation the cost and ergonomics of this particular rack, Caterpillar's last and of less importance priority. Proper ergonomic design is necessary in order to prevent repetitive strain injuries which can develop over time by improper handling of the rack. Cost effectiveness was determined by comparing the transportation fees associated with shipping the bolster using the current rack and the new rack design.

4 Design Considerations:

In the beginning of this project we received a list of design considerations directly from CAT. These considerations were accounted for throughout the entire project. These specifications and considerations included shipping four bolsters per rack, being able to stack the rack when loaded/unloaded with bolsters, establish safe handling during transportation, and finally part orientation of the bolster on the rack.

Firstly, in order to calculate the dimensions of the rack, the dimensions of the bolster were taken into consideration. According to Caterpillar's specifications, four bolsters had to fit on a rack.

Table 1. Physical Dimensions of Bolster.

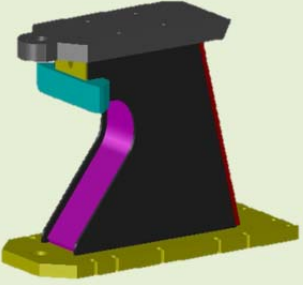
Bolster Dimensions		
	Mass	166.2 kg
	Length	872.5 mm
	Width	350 mm
	Height	517 mm

Secondly, since the racks are transported by truck from the supplier to the assembly facility in Suzhou, the truck dimensions were also important to consider. As we realized we could not control the dimensions of the truck we used them as a general guide to build our rack. Table 1 above shows the truck dimension heights used to build our rack.

Our last final consideration was the forklift dimensions. They had to be taken into account since

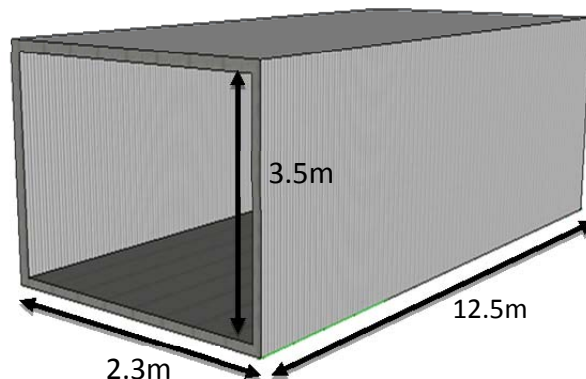

Figure 5. Truck Dimensions.

forklifts are used to move the racks from the trucks in and out of the manufacturing facility. The dimensions of the forklift were obtained during our visit at Caterpillar Suzhou.

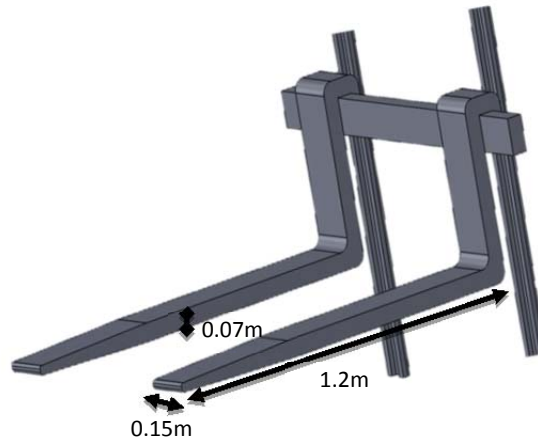

Figure 6. Forklift Dimensions.

4.1 Design Priorities

We were also asked by the engineers at Caterpillar Suzhou to consider the factors shown in Fig. 7 in our design process. Safety comes first to their company followed by quality, transportation and cost.

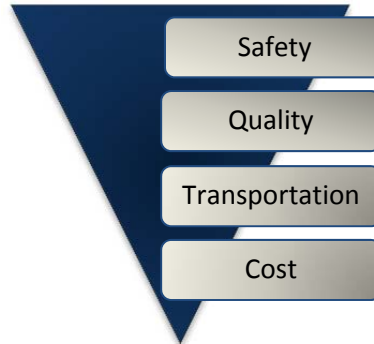

Figure 7. Caterpillar Design Priorities.

5 Design Process

From this information we were able to start our convergent design process. A convergent design process was the best way to create the best product for Caterpillar. With this idea we started with three alternative designs, which were reviewed, analyzed, and was then shown to Caterpillar for their input.

5.1 Design Phase One

In phase one of our convergent design process we started with three alternative designs. Our designs were held with specific design considerations given to by us by Caterpillar as mentioned above. Each of the three racks can accommodate four bolsters and can be stacked three levels high. All the three racks also have a bar on the side to prevent the bolsters from falling sideways. As each of our designs met the given requirements, each rack did it in its own unique way. Fig.8 below, shows the isometric view of each design.

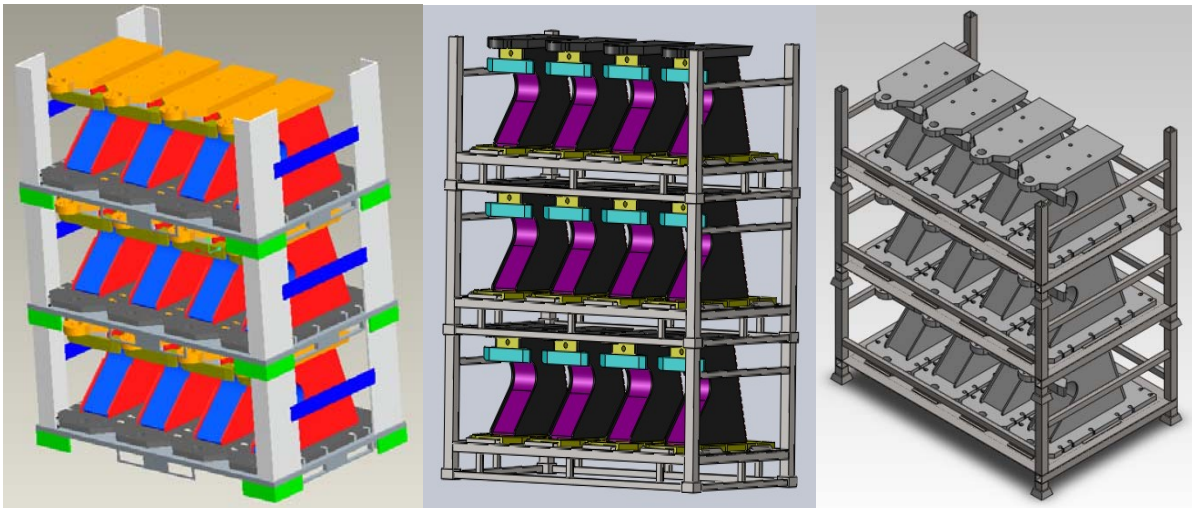

Figure 8. Design Alternatives of Phase I.

From these figures you can see the comparison of the three designs. The first rack idea used an “L” shape foot design to help limit the overall length and width of the rack for more adequate shipping. In design one, no solid plate was used in order to reduce the amount of material used and also to make the rack as light as possible.

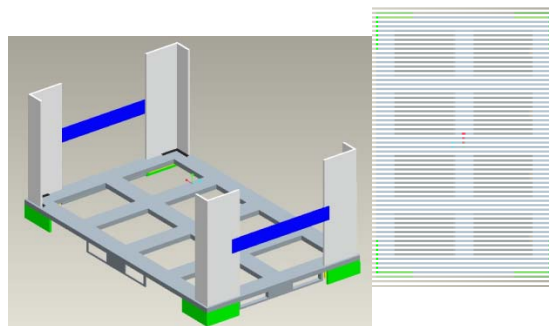

Figure 9. Isometric and Bottom View of Design Alternative 1.

Design two allowed a variety of spots for the forklift driver to pick up the rack while design three helped with ease of stacking in the warehouse for Caterpillar. Small metal pieces were welded to the solid plate to separate the bolsters and to prevent them from sliding forward or backward. The feet of rack two were hollow square tubes which allow the racks to fit on top of each other.

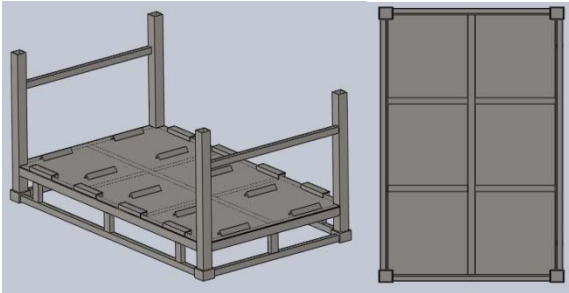

Figure 10. Isometric and Bottom View of Design Alternative 2.

The main distinguishing feature of design 3 was the foot design. It has a “hoof” structure or wide legs which allow the racks to be stacked. The forklift access was like channels and its bottom structure involved more cross members than design two.

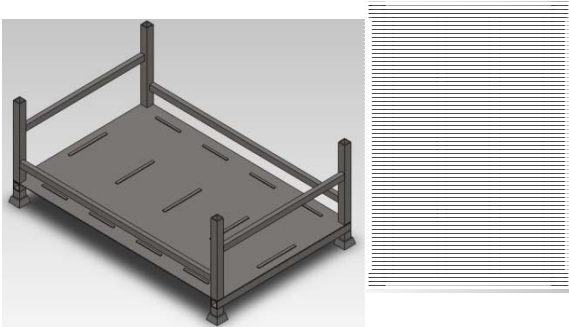

Figure 11. Isometric and Bottom View of Design Alternative 3.

After the three alternative rack designs were created we then were able to compare the physical properties of each design. Table 2 shown below compares each design.

Table 2. Physical Properties of the design alternatives 1,2 and 3.

	Rack #1	Rack #2	Rack #3
Mass of rack with 12 bolsters (kg)	2751	2449	2591
Mass of Rack (kg)	238	151	186

Height (Three stacked, mm)	1897	1993	1948
Rack Length (mm)	1472	1740	1636
Rack Width (mm)	945	1020	1086

From this table we were able to compare the mass of the rack loaded and unloaded with bolsters, the height of three racks stacked, and the rack length and width. One thing to notice from this table is that with the “L” shaped legs we were able to save a significant amount of space compared to rack two and three. One disadvantage with rack one was the mass of the rack being the highest at 238 kg while rack design two and three were both under 200 kg. From this table we were able to compare the physical pro’s and con’s of each rack alternative.

The next step in phase one involved running an ALGOR analysis on each rack design to determine the deflection, Von-Mises, maximum principle stress, and the strain the rack experiences. During this step we calculated the Pressure that each rack would specifically experience from the load of four bolsters, and the load the legs of the rack with experience with two loaded racks stacked on top. The calculations are shown in Appendix D. Table 3 below shows the different loads applied to each rack design specifically.

Table 3. Loads applied to design alternative 1,2 and 3.

	Rack #1	Rack #2	Rack #3
Upper Leg (MPa)	1.289	3.634	4.032
Lower Leg (MPa)	1.436	3.990	2.361
Bolster Load Applied (N/m²)	8918.37	4549.28	3511.27

After these loads where calculated we loaded the rack into ALGOR and was able to apply the specific loads in order to see the racks deformation. Fig.12 below shows each rack’s max Von-Mises Stress, indicated by the red flag.

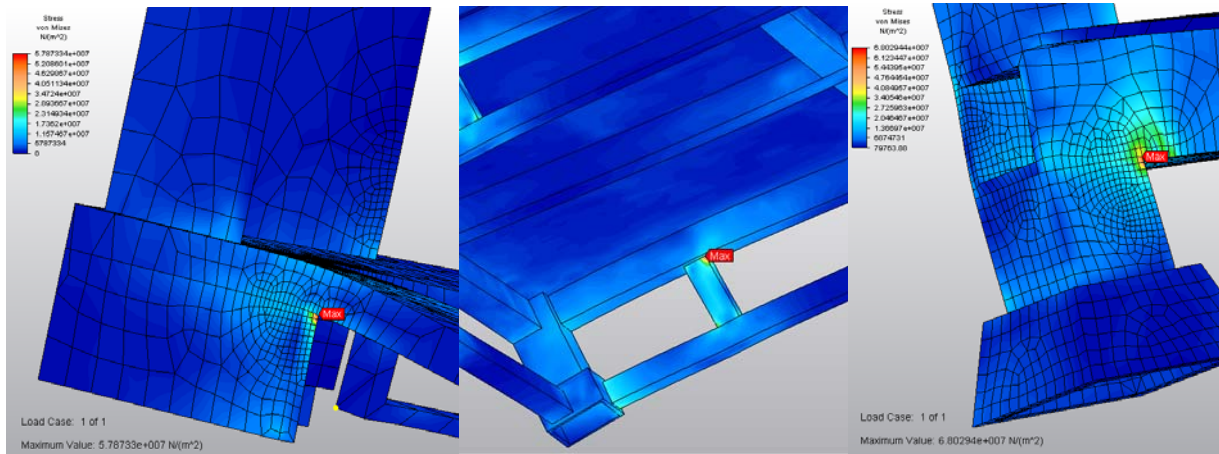

Figure 12. Maximum Von Mises Stresses of Design Alternatives 1,2 and 3.

Table 4 below represents the data gathered after running these ALGOR analyses.

Table 4. Data from ALGOR analyses.

	Rack #1	Rack #2	Rack #3
Deflection (mm)	0.221	0.254	0.248
Von-Mises Stress (MPa)	57.9	49.4	68
Maximum Principle Stress (MPa)	83.2	71.7	83.6
Strain (%)	0.04	0.03	0.04

From these values we were able to compare how each rack handled not only the load of four bolsters but the load of two racks stacked on top of it with bolsters loaded. We also were able to determine that, between each rack, the deflection was negligible, and this was confirmed through the maximum stress being so low compared to the yield strength of metal, specifically steel.

After all of this information was gathered we were able to go to Caterpillar and discuss our three different design alternatives with them.

Feedback from Caterpillar proved to be helpful for the convergent design process. From key informant interviews we were able to learn things that appealed to Caterpillar and things that did not. Feedback included; making fork access point on all four sides, as to not restrict

transportation of the rack, the hoof foot structure would be preferred since partially already in use, investigate the possibility of a foldable rack, decrease the clearance between each bolster, and finally make sure the rack can be balanced with any number of bolsters loaded onto it. This feedback from Caterpillar helped to lead us to our ultimate design.

5.2 Design Phase Two

From the first phase of the convergent design process we were able to take the feedback received from Caterpillar and come up with two new racks. (Insert next sentence)

With the design considerations given to us from Caterpillar we were also able to understand how they had prioritized these considerations. Caterpillar stated that safety was the most important feature in any rack designed, next quality, then transportation, and finally cost. With all of this in mind we were able to proceed with the design phase of two new racks.

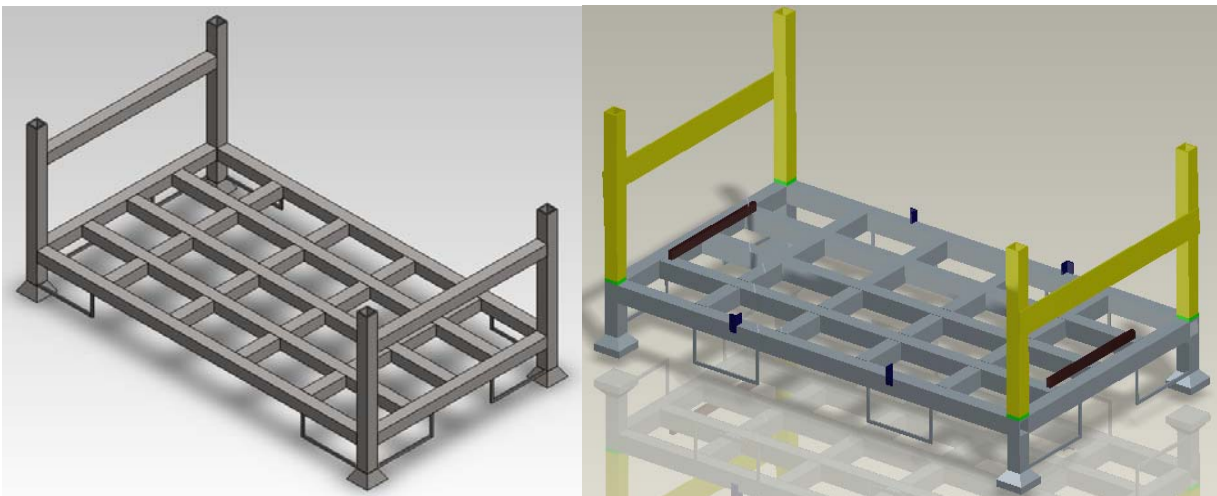

Figure 13. Non-foldable and Foldable Racks from design phase 2

From Fig.14 above you can see two new rack designs. Also you will notice the similarities in both racks. After the meeting with Caterpillar a new set of design considerations were developed.

- ❖ Investigate the necessity of a plate
- ❖ Consider the possibility of a foldable rack

With these new considerations the new racks were developed. The two main differences focused on these designs involved incorporating a foldable option. The design on the left above incorporates a solid piece leg design while the one on the right has two pieces for the leg; one is secured on the rack while the yellow legs lift off for a space saving design during transportation, 517 mm were able to be saved.

Table 5. Physical Dimensions of Phase 2 Rack.

Physical Property	Value
Mass per rack + 4 bolsters (kg)	797.7
Mass per rack (kg)	120.5
Rack Height (mm)	712
Rack Length (mm)	1700
Rack Width (mm)	972

Table 5 above shows the basic size and weight dimensions which were implemented in both of the alternative rack designs. We decided that these basic size dimensions were something that should stay constant throughout the rest of the project.

By keeping the dimensions the same we were able to focus on the core structure of the rack along with investigating other rack improvements. We were able to determine that having a physical plate for which the bolster to rest was unnecessary. This was done by the Finite Element Analysis software in Solid Works. Table 6 below shows the displacement of each rack, with and without a plate.

Table 6. FEM analysis of rack with and without plate.

	Rack with plate	Rack without plate
Deflection (mm)	0.221	0.468
Weight (kg)	149.53	120.40
Von-Mises Stress (MPa)	18.9	38.4
Strain (%)	0.006	0.013

From this table you can see the comparison of a rack with and without a plate on the core structure. A difference of 0.247 mm was calculated after both analyses was completed. From the small deflection change we were able to determine that the added weight of the plate does not benefit the change in deflection. Without the plate we also learned that the Von-Mises Stress does increase but only by 19.5 MPa which is far from the tensile strength of steel. From performing these analyses we were able to determine a solid plate was not a necessity for our final rack design.

Once both new rack designs were 3D modeled and tested we were able to discuss with Caterpillar the rack designs and get feedback back for the final rack design. Their feedback included the following comments:

- They were concerned about the interaction fit between the male and the female parts of the foldable rack
- The distance between the forklift access points was too wide

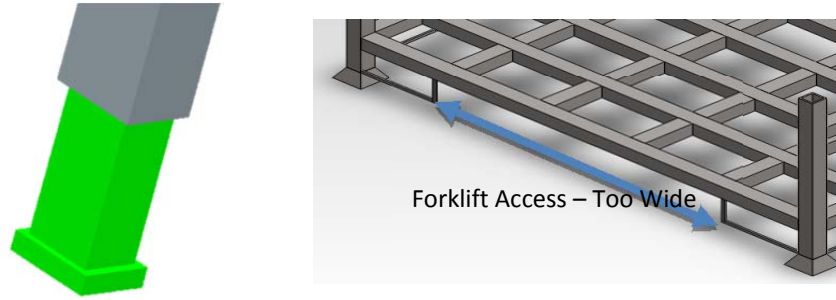

Figure 14. Interaction between male and female parts of leg, forklift access of Rack 2 is too wide.

From this feedback we were able to continue our convergent design process.

6 Results

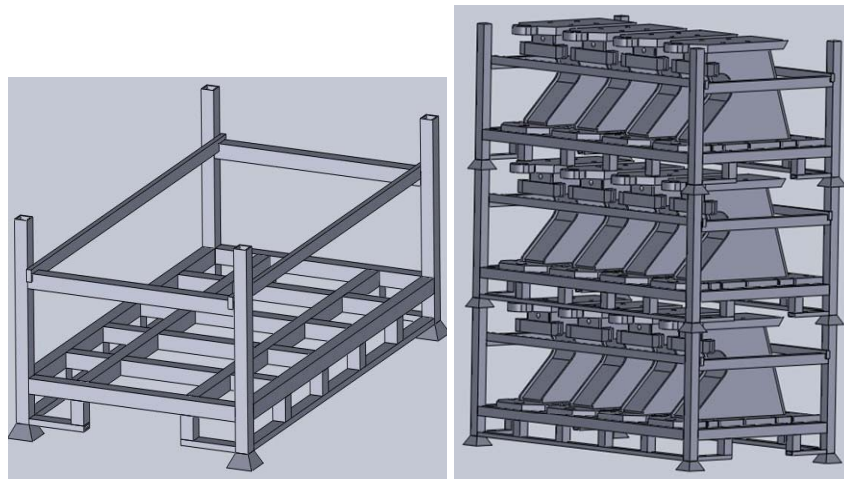

Figure 15. Isometric View of final rack design and when it is stacked 3 level high.

Using Caterpillar's design requirements and feedback, the final rack design was developed. In comparison to the previous racks developed, the final rack was the lightest and it weighs 146.1 kg. Table 7 shows the physical properties of the final rack design.

Table 7. Physical Dimensions of Final Rack.

Physical Property	Value
Mass per rack	146.1 kg
Mass per rack + 4 bolsters	824 kg
Height of 3 racks stacked	2061 mm