

Hydroponic Farming in Mahasarakham: Integrating Hydroponics into the Agricultural Curriculum While Promoting Entrepreneurial Skills



By: Aubrey Ortiz, Hilary Rotatori, Liz Schreiber, George von Roth

This report represents the work of one or more WPI undergraduate students submitted to the faculty as evidence of completion of a degree requirement. WPI routinely publishes these reports on its web site without editorial or peer review.

Hydroponic Farming in Mahasarakham:

Integrating Hydroponics into the Agricultural Curriculum While Promoting Entrepreneurial Skills

An Interactive Qualifying Project Report
submitted to the Faculty of
WORCESTER POLYTECHNIC INSTITUTE
in partial fulfillment of the requirements for the
Degree of Bachelor of Science
by

Aubrey Ortiz
Hilary Rotatori
Elizabeth Schreiber
George von Roth

Date: March 5, 2009

Report Submitted to:

Professor Richard Vaz
Professor Chrysanthe Demetry
Mahasarakham University Students in Free Enterprise Chapter

This report represents the work of one or more WPI undergraduate students submitted to the faculty as evidence of completion of a degree requirement. WPI routinely publishes these reports on its web site without editorial or peer review.

ABSTRACT

In Northeast Thailand, dependence on agricultural productivity and geographical conditions contribute to underdevelopment and poverty. These factors can be alleviated by alternative farming techniques such as hydroponics. The goal of our project was to design and construct a hydroponic system for the MSU Demonstration School that can be integrated into the agricultural curriculum while introducing business skills. This report includes recommendations for our sponsor, the MSU SIFE team, to assess the operation and educational use of the hydroponic system.

ACKNOWLEDGEMENTS

Our team would like to thank the many people who helped us throughout this project.

First, we would like to thank our project sponsor, Ajarn Andrew Cottam, for his help and dedication throughout the project and for providing us with housing and transportation in Mahasarakham.

We would also like to thank Ajarn Pongsatorn Tantrabundit for his time and effort spent as a valuable translator during interviews and purchasing materials.

We would like to thank the Mahasarakham University SIFE team for their hospitality and help with the construction of the hydroponic system.

We would like to thank Dr. Yuji Niino and Hiroshi Kodama of the Food and Agriculture Organization who took time to meet with us and provide us with information on hydroponics.

We would like to thank Worcester Polytechnic Institute and Chulalongkorn University for allowing us the opportunity to come to Thailand to complete this project.

Finally, we would like to thank our Worcester Polytechnic Institute project advisors, Professor Chrysanthe Demetry and Professor Richard Vaz for their generous advice and unrelenting support throughout this entire project. We would also like to thank Professor Dominic Golding for his contributions in helping us prepare for this project.

EXECUTIVE SUMMARY

Rural poverty is a major problem in the underdeveloped areas of Thailand. One of the poorest regions in Thailand is the Northeast. In 2002, there were 3.8 million poor living in the Northeast compared to 2.3 million in the rest of the country combined (Thailand's National Economic and Social Development Board [NESDB] & World Bank, 2005). A major reason for poverty in the Northeast region is the lack of agricultural productivity. Northeast Thailand comprises a total land area of about 66,000 square miles. However, only 59% is capable of being farmed (Rigg, 1985) due to high salinity, a lack of natural resources, and the use of unsustainable farming methods that have stripped the soil of its nutrients (Thailand's NESDB & World Bank, 2005).

His Majesty the King, the Thai government, and other organizations have taken initiatives to address the problem of poverty due to a lack of agricultural production in Thailand. These efforts have aimed for overall community development, the improvement of the quality of land, and the introduction of alternative farming methods as a stimulus for economic growth. One such plan is the "New Theory" which was created by His Majesty the King following the economic crisis of 1997 and aims to promote a self-reliant economy (Gypmantasiri, 2001). Another plan is the 10th National Economic and Social Development Plan, which aims to create or adapt a self-sufficient economy, so as to increase the profits of various businesses (Assawin, 2007). A project was created in 2003 by a government agency, which attempted to increase the fertility of poor soil by irrigating the soil with water from surrounding areas (Molle & Floch, 2008). In addition, the Food and Agriculture Organization (FAO) started a project in 2003 that introduced hydroponic as a way to help farmers in the south who were affected by the tsunami (Wild Life Fund Thailand and Food and Drug Organization, 2006).

Since efforts to reduce rural poverty and increase agricultural production in Thailand have only had moderate success, other ways of solving the problem can be introduced. Alternative farming methods have emerged as a potential solution to this problem. A promising technique is hydroponic farming, in which plants are grown in a nutrient solution without the presence of soil. Hydroponic farming has the potential to increase agricultural production in the Northeast because it does not involve the use of the infertile soil in this area and has been used in Thailand before in the FAO project as mentioned above.

Case studies suggest that hydroponics can be effectively taught in the classroom, which may be helpful in promoting the idea of hydroponics to students in rural areas of Thailand. A non-profit organization, called Students in Free Enterprise (SIFE), has been involved in implementing hydroponics at schools in Northeast Thailand. The goal of SIFE is to promote business through the principles of free enterprise and community outreach projects. The SIFE chapter at Mahasarakham University designed and constructed a hydroponic farming system in the rural village of Ban Ma Kok in 2008; however, the system was destroyed in a storm later that year. In addition to the structural problems which were identified following the storm, the SIFE team also determined that the students at the village school were not fully engaged with the system and therefore neglected it. The SIFE team wanted to try to

implement a hydroponic system at the Maharakham University Demonstration School which is a more promising site for implementation because the system can be integrated into the school's agricultural curriculum. We were contacted by the MSU SIFE team to help them design and construct a new hydroponic system and aid them in their efforts to implement the system at the Demonstration School.

The goal of our project was to design and construct a hydroponic system for the Maharakham University Demonstration School that could be integrated into the agricultural curriculum while introducing business skills to the students. We accomplished this goal by completing the following objectives:

1. Understanding the needs and goals of the MSU SIFE team and assessing the previous hydroponic system.
2. Designing the hydroponic system.
3. Constructing the selected hydroponic system.
4. Developing educational materials on agriculture and the use of hydroponics.
5. Recommending interactive and engaging activities for the students introducing entrepreneurial skills.

To complete these objectives, we traveled to Maharakham where we gathered information about the previous system and user requirements in order to develop the design criteria used when choosing a design for the structure. We selected the type of hydroponic technique, frame shape, and materials to build the system, based on the user requirements and design criteria determined from our interviews and assessments of the previous hydroponic system.

As a basis to create a teaching manual that is intended to help integrate the hydroponic system into the agricultural curriculum, our group gathered information about the overall structure of the teacher's classroom, the current curriculum on hydroponics and agriculture, and what the teacher thought about our ideas on teaching hydroponics.

In order to create business activities for the MSU SIFE team, we used our ideas, information from relevant case studies, and information gathered from discussions with the SIFE team to give the SIFE team a recommendation for engaging business activities for the MSU Demonstration School students. We intend for our recommendation to serve as a foundation for the SIFE team to create their own activities to implement at the school.

We created design criteria by drawing upon the user requirements, successes and failures of the previous hydroponic system, and research on existing hydroponic systems. The criteria identified were:

- Durable structure
- Modular
- Replicable

- Easy to operate and maintain
- Suitable for healthy vegetable growth
- Low cost

We chose a hydroponic system design based on which of our preliminary designs best satisfied these design criteria. From our knowledge about the previous system and the information gathered from the Food and Agriculture Organization (FAO), we chose the dynamic root floating technique (DRFT) because it is the most cost effective technique, has several methods to manage and reduce heat in the system, and was used by the MSU SIFE team in their previous system. We chose a semi-Quonset design frame that is made of steel for the hydroponic system, which is modular allowing for disassembly and transport if needed. The hydroponic bed measures one and a half meters wide by six meters long and can support and grow approximately 730 plants in one harvest. It was designed to be replicable by using locally available materials because if the system is successful at the school then SIFE will replicate and implement the system in other areas of Thailand. The design is shown in Figure 1 and a photograph of the constructed hydroponic system is shown in Figure 2.

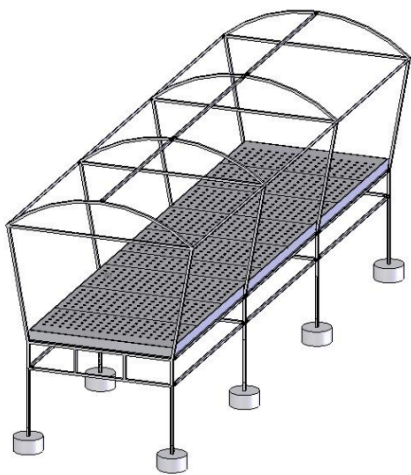

Figure 1: The Semi-Quonset Design (Left)
 Figure 2: Constructed Hydroponic System (Right)

As suggested by case studies, when hydroponics is integrated into the science and agricultural curriculum, students are more likely to be engaged in academic activities. We created a teaching manual for the agricultural teacher at the Mahasarakham Demonstration School to help integrate the hydroponic system into his curriculum. The teaching manual contains suggested topics on plant biology, the science and history of hydroponics, and maintenance of the hydroponic system. We included four individual and team activities that correspond with the suggested topics and are intended to be an engaging way to reinforce the lesson learned.

Our group also developed three business activities for the MSU SIFE team. These activities are the hydroponic vegetable business fair, the hydroponic vegetable stock market, and owner and vendor role playing. The SIFE team can use our activities or adapt our ideas to create activities of their own. The business activities are intended to accomplish the mission

statement of SIFE of promoting business practices, entrepreneurship, free enterprise, and environmental sustainability while being fun and engaging.

If the hydroponic system is a success at the MSU Demonstration School, the SIFE team would like to replicate and integrate the system into other school curricula in Northeast Thailand. In order for SIFE to determine whether or not the system is successful, we recommend that SIFE assess the overall performance of the system and the system as an educational tool.

To monitor the performance of the hydroponic system, we recommend that the SIFE team perform assessments on the following:

How well is the system operating?

The SIFE team can determine if the system is currently in operation by speaking with Ajarn Aathit. If the system is currently being used, then the SIFE students can gather Ajarn Aathit's opinions on its operation. If the system is not in use, then the SIFE team can determine the reasons why. Finding this information would be helpful to the SIFE team because they can investigate possible ways to re-implement or relocate the system to another school if they feel it is the best option.

How well is the system being maintained?

In order to determine if the system is being properly maintained, the SIFE team can speak with Ajarn Aathit about any problems that he has had with the maintenance of the system and also observe the class during activities that involve the operation of the system. The SIFE team can assess the maintenance of the system and determine if they need to reinstruct the teacher and students in accordance with the operation manual. This assessment is valuable to the SIFE team because the results will allow them to see if the operation manual provides enough information on the maintenance of the system and if not, they can make adjustments to fit their needs.

How efficiently has the system been growing vegetables?

The SIFE team can monitor the efficiency of the system in growing healthy vegetables by keeping a record of observations of the plant growth in the hydroponic system. Similar to the observation journal activity in the teaching manual, the SIFE team can record information such as the number and sizes of plants, how healthy they appear to be, and if there have been any pests or diseases detected. This assessment can be beneficial to SIFE because they can determine important information about the efficiency and productivity of the system which can be helpful in the future if they chose to use it to make a profit.

How does the actual yield of the system compare with the expected yield?

From the information gathered from the previous assessment, SIFE can also compare the actual yield of the system with the expected yield by counting the number of plants successfully harvested. This number can be compared to the maximum yield of approximately 730 plants per harvest. As with the previous assessment, SIFE can use this

assessment to determine how productive and efficient the system has been to see if they should investigate the possibility of replicating the system to grow plants for a profit.

To assess the hydroponic system as an educational tool, we recommend that SIFE assess the following:

Is the system being used by the teacher in the classroom?

The SIFE team can determine if the system is being used in the classroom by talking with the teacher and students about how they have used the hydroponic system. If the teacher is using the system in his curriculum, then the SIFE team could explore exactly how it is being used. However, if the system is not being used then the SIFE team should identify why. Also, it would be beneficial to know what has worked well with the system and what has not, so the SIFE team can make changes or adjustments for future projects.

Are the teaching materials being used by teacher in the classroom?

It is also important for the SIFE team to determine if the teacher is using the teaching materials in the classroom by speaking with him about what specific information or activities he used. Again, similar to the hydroponic system, it would be beneficial to learn what material he found useful and what was not.

Are there students interested in the hydroponic system outside of the classroom?

By identifying if the students have expressed interest in the system outside the classroom, the SIFE team can assess how engaging and interesting the students found the curriculum, activities, and the hydroponic system. The SIFE team can speak with the teacher to see if any students have expressed outside interest or they can speak with the students directly themselves. If the students are interested, the SIFE team can look into the possible options of replicating the system at other schools or creating more extracurricular activities for the students.

Has SIFE been able to use the system to achieve their goals?

The SIFE team can evaluate how well the system has helped them achieve their goals. They can assess whether or not the students learned about business and entrepreneurial skills and the environmental impacts and benefits of hydroponics. The SIFE team can speak with the teacher and the students to see if these learning outcomes were achieved.

Throughout the course of this project, we were able to gain valuable knowledge about Thai culture, teamwork, and ourselves. We hope that the hydroponic system and educational materials produced over the course of this project will be helpful to the SIFE team and the MSU Demonstration School and perhaps others in the future. If the system proves to be effective as an educational tool, we hope that it could be readily replicated elsewhere in Northeast Thailand and have a positive impact on other educational programs and communities.

CONTRIBUTIONS

Aubrey Ortiz

Aubrey was our primary researcher on the technical aspects of hydroponics. He was active in the preliminary design process for the hydroponic system and in the procurement of materials for construction. Aubrey contributed to the content of the teaching, operation, and fabrication manuals. He created many of the diagrams and pictures found in these manuals. Aubrey was also responsible for content in the preliminary drafts of the Background, Methodology, Findings, and Recommendations sections of the report. In addition, he helped with the editing of the final draft of the report.

Hilary Rotatori

With Elizabeth, Hilary was a primary writer and editor for all sections of the report. She was responsible for drafts and finalization of the Executive Summary and Reflections sections of the report. Hilary co-authored the Introduction of the report along with Elizabeth. She took the main responsibility of determining the structure of the teaching manual and explaining the activities included in the manual. Hilary was also the primary author of the chapter introductions and summaries throughout the report. In addition, Hilary was the primary researcher on poverty and underdevelopment in Thailand and the SIFE organization. With Elizabeth, Hilary researched material on educational hydroponics.

Elizabeth Schreiber

With Hilary, Elizabeth was a primary writer and editor for all sections of the report. She contributed to the draft and finalization of the Abstract of the project along with George. Elizabeth was responsible for the formatting of the report and manuals. She also co-authored the Introduction of the report along with Hilary. Elizabeth also had the main responsibility of presenting and writing explanations of the business activities that will be given to the MSU SIFE team. In addition, Elizabeth was the primary researcher on the hydroponic system previously built by the MSU SIFE team and agricultural policies in Thailand. With Hilary, Elizabeth researched material on educational hydroponics.

George von Roth

George served as the main liaison between our team and our project advisor and MSU students. George also conducted most of the research on simplified hydroponics. He was responsible for a majority of the technical drawings used in the design and construction of the system. He was active in the procurement of materials for the hydroponic system. George contributed to the draft and finalization of the Abstract of the project along with Elizabeth. George was also responsible for content in the preliminary drafts of the Background, Methodology, Findings, and Recommendations sections of the report. In addition, he helped with the editing of the final draft of the report.

Team

All team members equally participated in interviews, the construction of the hydroponic system, and the creation of presentation materials.

TABLE OF CONTENTS

Abstract.....	i
Acknowledgements.....	ii
Executive Summary.....	iii
Contributions.....	viii
Table of Contents.....	ix
List of Figures.....	xii
List of Tables.....	xiii
Introduction.....	1
Background.....	3
Poverty and Underdevelopment in Northeast Thailand.....	3
Efforts to Reduce Poverty in Thailand by Increasing Agricultural Production.....	5
Policies in Thailand.....	5
Initiatives of the Food and Agriculture Organization.....	6
Basics of Hydroponic Technology.....	6
Plant Physiology.....	7
The Nutrient Solution.....	8
Hydroponics vs. Traditional Farming.....	8
Types of Hydroponic Techniques.....	9
Building and Operating Hydroponic Systems in Low Resource Areas.....	11
Hydroponics in Education.....	13
Case Study 1: Uruguay Kindergarten Hydroponic Education Program.....	13
Case Study 2: Alaskan High School Hydroponic Educational Program.....	14
MSU SIFE Team and Their Hydroponic System.....	15
Methodology.....	18
Objective 1: Understand the Needs and Goals of the MSU SIFE Team and Assess the Previous Hydroponic System.....	18
Objective 2: Design the Hydroponic System.....	19
Objective 3: Construct the Selected Hydroponic System.....	21
Objective 4: Develop Educational Materials on Agriculture and the Use of Hydroponics.....	22
Objective 5: Recommend Interactive and Engaging Activities for the Students Introducing Entrepreneurial Skills.....	23
A Hydroponic System for the MSU Demonstration School.....	25

Design Criteria for the Hydroponic System.....	25
Choice of Hydroponic Technique	26
Choice of the Hydroponic System Frame	27
Materials to Build the Hydroponic System.....	29
Construction of the Hydroponic System	30
Educational Materials	32
Teaching Manual.....	32
Business Activities	36
Summary, Recommendations, and Reflections	39
Summary of Project Outcomes	39
Hydroponic System	39
Teaching Manual	40
Business Activities	40
Recommendations for Future Work.....	41
Monitoring the Hydroponic System	41
Evaluating the Educational Uses of the System	42
Reflections.....	43
References.....	45
Appendix A: Interview Guides and Summaries	48
Email Questions: MSU SIFE Team	49
Email Summary: MSU SIFE Team.....	50
Interview Guide: MSU SIFE Team Advisor.....	52
Interview Summary: MSU SIFE Team Advisor	53
Interview Guide: FAO in Bangkok	54
Interview Summary: FAO in Bangkok	55
Interview Guide: MSU Demonstration School Teacher	57
Interview Summary: MSU Demonstration School Teacher	58
Appendix B: Information on Constructing a Hydroponic System.....	61
Frame Fabrication Manual	61
Additional Information on Constructing a Hydroponic System	71
Appendix C: Pair-Wise Comparison Chart.....	77
Appendix D: Summative Teamwork Assessment	78
Appendix E: Team Members' Cultural Essays.....	84

Appendix F: Educational Materials: Teaching Manual, Operation Manual, and Business
Activities91

LIST OF FIGURES

Figure 1: The Semi-Quonset Design (Left).....	v
Figure 2: Constructed Hydroponic System (Right).....	v
Figure 3: Regional Number of Poor in Urban and Rural Areas in Thailand, 2002.....	4
Figure 4: Regional Map of Thailand	4
Figure 5: Nutrient Film Technique.....	9
Figure 6: Ridged Culture Bed of a DRFT System	10
Figure 7: Concave Panels under Styrofoam in DRFT System.....	10
Figure 8: Water Culture Method	11
Figure 9: Ebb and Flow System	11
Figure 10: Vegetables in Styrofoam Sheets in MSU SIFE Team Hydroponic System (Left)	16
Figure 11: Channels Constructed Using Plywood in MSU SIFE Team Hydroponic System (Right).....	16
Figure 12: Lining of the Channels with Polyethylene Plastic in the MSU SIFE Team Hydroponic System (Left)	16
Figure 13: Plastic Sheeting for Roof and Mosquito Nets on the Sides in the MSU SIFE Team Hydroponic System (Right)	16
Figure 14: Development of Design Criteria	19
Figure 15: Generic Pair-Wise Comparison Chart	20
Figure 16: Quonset Frame Design.....	27
Figure 17: A-Frame Design.....	27
Figure 18: Semi-Quonset Frame Design	28
Figure 19: Semi-Quonset Frame Partially Deconstructed for Transportation.....	28
Figure 20: Fabrication of the Frame	30
Figure 21: Construction of the System.....	31
Figure 22: Ridges of DRFT	31
Figure 23: Hydroponic System.....	39

LIST OF TABLES

Table 1: Percent Concentrations of Essential Nutrients in Dry Tissue of Plants	7
--	---

INTRODUCTION

Poverty and economic underdevelopment are major problems in rural areas of developing countries. There are 900 million impoverished people living in rural areas around the world (IFAD, 2001). Ideally, a rural community would be able to support itself through agricultural production to meet basic needs while also growing a surplus to sell in local and regional markets. Unfortunately, many parts of Thailand lack the necessary resources to produce sufficient foodstuffs for both local consumption and sale. The soil conditions of Northeast Thailand, also known as Isan, limit the range of agricultural practices that can be pursued. Of the 66,000 square miles of land in the Northeast, only 59% is capable of being farmed (Rigg, 1985) due to the high salinity of the soil, deforestation of the land and the use of unsustainable farming methods (Thailand's National Economic and Social Development Board & World Bank, 2005).

In response to the issues of poverty and underdevelopment in rural areas, His Majesty the King and the Thai government developed two major policies called the "New Theory" (Gypmantasiri, 2001) and the 10th National Economic and Social Development Plan (Jirapaet, 2007). Two desired outcomes of these plans are to increase the production of food and develop self-sufficient communities in order to decrease poverty. In addition to these policies, the Thai administration initiated a project in 2003 to improve the fertility of the poor soil in the Northeast by irrigating it with water from surrounding areas. However, this project was abandoned due to existing problems with the saline soil, low profitability, and cost effectiveness (Molle & Floch, 2008).

Since efforts to improve the quality of the soil have been unsuccessful, other methods of increasing agricultural production, such as the use of alternative farming techniques, may be more feasible. One farming technique that has been used in Thailand is hydroponics, a method of growing plants using mineral nutrient water without soil. In southern Thailand in 2004, a project was started by the Food and Agriculture Organization (FAO) using hydroponics as an alternative farming method to provide additional income to farmers affected by the tsunami (Wildlife Fund Thailand and FAO, 2006). This project showed that hydroponics has the potential to increase agricultural production. In addition, there been several successful large scale commercial hydroponic farms in other areas of Thailand.

Since hydroponics is an unconventional and unfamiliar farming technique, incorporating hydroponics into rural areas of Thailand may be difficult. Several case studies suggest that a hydroponic system can be integrated into the agricultural curriculum at schools in order to teach the students about hydroponics and promote its use to the younger generation. In addition to helping students understand this farming technique, another benefit is that a hydroponics curriculum can cover a variety of topics such as science, math, history, and business skills.

One non-profit organization, called Students in Free Enterprise (SIFE), has been involved in implementing hydroponics in Northeast Thailand. Their mission is to promote and educate

business and entrepreneurial skills through the principles of free enterprise. The SIFE chapter at Mahasarakham University designed and constructed a hydroponic farming system in the rural village of Ban Ma Kok in 2008. Their goal was to produce vegetables for the school lunch as well as provide additional income for the community. Unfortunately, the hydroponic system was destroyed in a storm later that year. Although the system yielded some vegetables before the storm, its structural design could not withstand the heavy rainfall and intense heat of the region. Another problem identified by the MSU SIFE team was that the system was not properly integrated into the teaching curriculum and student activities, causing the system to be neglected. Since the hydroponic system was not successful in the village of Ban Ma Kok, the MSU SIFE team decided to implement a pilot program at the Mahasarakham University Demonstration School.

The goal of our project was to design and construct a hydroponic system for the Mahasarakham University Demonstration School that could be integrated into the agricultural curriculum while introducing business skills to the students. We accomplished this goal by completing the following objectives:

1. Understanding the needs and goals of the MSU SIFE team and assessing the previous hydroponic system.
2. Designing the hydroponic system.
3. Constructing the selected hydroponic system.
4. Developing educational materials on agriculture and the use of hydroponics.
5. Recommending interactive and engaging activities for the students introducing entrepreneurial skills.

We believe that integrating hydroponics education into the agricultural curriculum, while introducing entrepreneurial activities, may benefit the students' education and encourage them to use these skills to their advantage in the future. We hope that our project will aid the MSU SIFE team in their efforts to expand the use and knowledge of hydroponics as an alternative farming method, in rural Thailand. We further hope that this project will eventually have a positive impact on the agricultural economy and promote a reduction in poverty in Northeast Thailand.

BACKGROUND

Over the past few decades, Thailand has experienced an overall decrease in poverty rates throughout the country due to national economic policies, developing technology, and increased involvement in the international market. While these efforts have been beneficial to urban areas, little success has been seen in rural areas in the Northeast. Several reasons contribute to the presence of poverty in this area of the country including the characteristics of the population and dependence on agriculture in the region. In addition to these factors, the soil in this region has become unsuitable for traditional farming methods, introducing the need for the implementation of sustainable farming techniques. One way of promoting the use of these techniques is to integrate hydroponics into the education system. This chapter focuses on the causes and efforts to reduce rural poverty in Thailand, the possibility of hydroponic farming as a sustainable farming solution, and case studies involving the use of hydroponics in education.

POVERTY AND UNDERDEVELOPMENT IN NORTHEAST THAILAND

According to the International Fund for Agricultural Development (IFAD), over 1.2 billion people around the world are in “extreme consumption poverty”, which means they live on less than one dollar per day. Of these 1.2 billion people, seventy-five percent of them live in underdeveloped rural areas. They are forced to spend 70-80% of their total income on food staples alone and most often do not receive the essential nutrients required to live a healthy life. While efforts have been made to reduce rural poverty, the progress has slowed significantly in the past ten years (IFAD, 2001).

Over two-thirds of people classified as living in “extreme consumption poverty” live in Asia making it an area of focus for poverty reduction efforts (IFAD, 2001). In Thailand, the poverty rate declined 17.2% from 1990 to 2002 (United Nations, 2008). Despite this progress, the poverty rate in rural areas is still 60% higher than in urban areas. In 2002, there were approximately 6.1 million poor living in Thailand, 800,000 of whom were in urban areas and 5.3 million of whom were in rural areas. Figure 3 presents urban and rural poverty statistics, showing the number of poor people per region in Thailand. These regions can be seen in the map in Figure 4. The Northeast region, also known as Isan, is the most inhabited and poorest region of Thailand. In 2002, there were 3.8 million poor living in the Northeast compared to 2.3 million in the rest of the country combined (Thailand’s NESDB & World Bank, 2005).

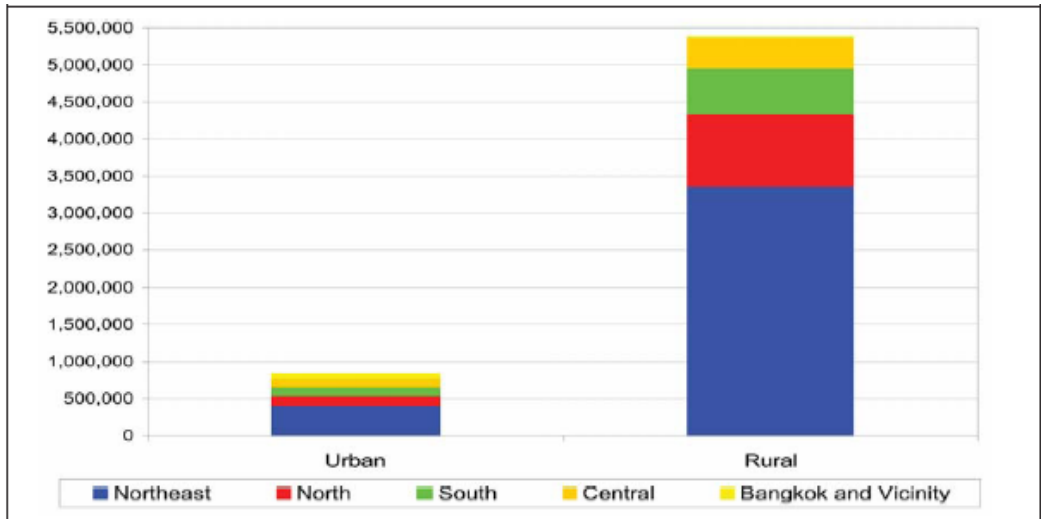

Figure 3: Regional Number of Poor in Urban and Rural Areas in Thailand, 2002
 Source: Thailand Northeast Economic Development Report (2005)



Figure 4: Regional Map of Thailand
 Source: www.thailandmapxl.com/political-map.html

Dependence on agricultural productivity in Northeast Thailand contributes to the poverty crisis. Despite the fact that Isan contains over half of the farms and two-fifths of the agricultural land in Thailand, it only accounts for one-fifth of the gross domestic product (Thailand’s National Economic and Social Development Board [NESDB] & World Bank,

2005). The lack of agricultural productivity is due to the geography of the region. Northeast Thailand is situated on a large plateau and comprises a total land area of about 66,000 square miles. Of this land, only 59% is capable of being farmed (Rigg, 1985). The land is not very fertile because of a lack of natural resources and the use of unsustainable farming methods that have stripped the soil of its nutrients. There is also considerable soil erosion due to deforestation and over one-third of the soil has elevated levels of salt (Thailand's NESDB & World Bank, 2005). A monsoon season spans from April to September and a dry season follows making it difficult for agricultural practices (Rigg, 1985).

In addition to geographical challenges, the education level of the people of Northeast Thailand does not allow many of them to stray from their traditional farming occupations. In 2004, 70% of workers in the Northeast were found to have less than a primary level of education (Thailand's NESDB & World Bank, 2005). With little opportunity to leave the area and receive higher levels of education, many people in Isan are unable to find well-paying jobs to support their families, which further contributes to poverty in this region.

EFFORTS TO REDUCE POVERTY IN THAILAND BY INCREASING AGRICULTURAL PRODUCTION

The Thai government and other organizations have developed several policies in an attempt to reduce poverty levels and increase agricultural production in Thailand. These efforts have aimed for overall community development, the improvement of the quality of land, and the introduction of alternative farming methods as a stimulus for economic growth.

POLICIES IN THAILAND

His Majesty the King formulated a plan called the "New Theory" in response to the economic crisis of 1997. This plan promotes a self-reliant economy and is comprised of three stages. The first stage is the promotion of self-reliant production systems; the second stage is the development of community independence; and the third stage is the creation of interdependency among private sectors and communities (Gypmantasiri, 2001). The New Plan has been adopted by various government agencies. Through the progression of these steps, the production of food should increase and the poverty in the country would subsequently decrease.

The Thai government also created a series of policies called the National Economic and Social Development Plans. The government revised these policies about every four years, beginning in 1961 (Assawin, 2007), to accommodate changes in the vision statements, the problems identified, and development strategies. The 10th Plan is for the years 2007-2011 and is still in the early stages of implementation (Jirapaet, 2007). A key strategy is "the serious adaptation and implementation of the 'Self-sufficiency Economy', to ensure more saving, frugality, self-dependency, fiscal disciplines, optimal investment, and good governance" (Assawin, 2007). This strategy aims to create or adapt a self-sufficient economy, so as to

increase the profits of various businesses and to ultimately decrease the amount of poverty in Thailand.

The Thai government has also tried to increase agricultural production and decrease poverty by improving the quality of the land available for agriculture, specifically in the Northeast region of Thailand. The main idea was to increase fertility of the poor soil by irrigating the soil with water from surrounding areas. One project, which began in 2003, aimed to interconnect man-made reservoirs and basins that would be used to transport the water to the irrigable land in order to increase agricultural production in the area and alleviate the poverty of the region. In 2006, the project was questioned by many experts who were concerned about the existing problems with saline soil and the profitability and cost effectiveness of the project. The project was intended to increase agricultural production and reduce poverty, but the problems became insurmountable and the project was abandoned (Molle & Floch, 2008).

INITIATIVES OF THE FOOD AND AGRICULTURE ORGANIZATION

After the 2004 tsunami hit southern Thailand, many organizations took initiatives to aid the millions of people affected. The Food and Agriculture Organization (FAO) helped by starting a project in 2006 which used hydroponics as an alternative farming method to provide additional income to farmers affected by the tsunami. This project implemented 80 hydroponic units in the Phang-Nga province and was completed in collaboration with the Wildlife Fund Thailand (WFT). The units were leased to farmers in villages and schools affected by the tsunami and were supplied with the startup and maintenance costs by the FAO. Since many people were in need of financial support in the years following the tsunami, the FAO focused on improving agricultural production as a way to provide additional income and stimulate the economy. The farmers were broken into groups and the production of the systems was monitored.

In the time period from July to November 2006, the farmers' income increased an average of 1,000 to 1,200 Baht for each harvest and expenses due to cultivation decreased.

Unfortunately, the FAO found that if the farmers had to pay for the cost of the hydroponic systems and maintenance themselves, they would most likely not make a profit. However, decreasing startup and maintenance costs would make it feasible for the farmers to make a profit. Although the farmers relied on the FAO for startup costs, this project showed that hydroponics has the potential to increase agricultural production in the Northeast as it has in the south (Wild Life Fund Thailand and Food and Agriculture Organization, 2006).

BASICS OF HYDROPONIC TECHNOLOGY

Hydroponics is a method of growing plants using mineral nutrient water instead of soil. Hydroponics, also known as soilless culture, has been around for thousands of years, dating back to the hanging gardens of Babylon and the floating gardens of the Aztecs. The first modern use of hydroponics was in the early 1930's by W. F. Gericke from the University of California. Gericke used a water culture method to grow plants such as tomatoes, beets,

carrots, potatoes, fruits, flowers, and more. In the 1940's, the United States Air Force used hydroponic systems to grow fresh vegetables for troops stationed on small islands in the Pacific. Currently hydroponic systems are used all over the world including areas with non-arable soil such as Mexico and the Middle East (Resh, 1997). Almost all terrestrial plants can be grown using hydroponics; however, high value crops are usually planted to offset the high startup cost. One way to improve the success of a hydroponic system is to understand the science behind it (Resh, 1997).

In order to explain the science behind hydroponics, this section will begin with a discussion of plant physiology and the nutrients a plant needs to survive. Next, we discuss the similarities and differences of hydroponic farming versus traditional farming, which leads into a description of several different kinds of hydroponic techniques. This section concludes with information on how to build and operate a hydroponic system in low resource areas.

PLANT PHYSIOLOGY

On average, plants are made of 80-95% water. The rest of the plant material, otherwise known as dry matter, composes 5-20% of the plant. Of this dry matter, 90% is made of carbon, oxygen and hydrogen. Plants receive these essential elements from carbon dioxide and water. The plant must take up the other 10% of the nutrients and minerals (about 1.5% of the dry weight) from the soil as dissolved ions in the water. Currently, there are 16 elements identified by biologists that are essential to plant life. These include nitrogen (6% of dry weight), potassium (1.5%), calcium (1.0%), and magnesium (0.5%) (Resh 1997). Table 1 shows the full list of essential elements and their percent concentration in the dry tissue of the plant.

Table 1: Percent Concentrations of Essential Nutrients in Dry Tissue of Plants
Source: Resh, 1997

Element	Symbol	Concentration in dry tissue (%)
Hydrogen	H	6
Carbon	C	45
Oxygen	O	45
Macronutrients		
Nitrogen	N	1.5
Potassium	K	1.0
Calcium	Ca	0.5
Magnesium	Mg	0.2
Phosphorus	P	0.2
Sulfur	S	0.1
Micronutrients		
Chlorine	Cl	0.01
Boron	B	0.002
Iron	Fe	0.01
Manganese	Mn	0.005
Zinc	Zn	0.002
Copper	Cu	0.0006
Molybdenum	Mo	0.00001

The process of ion absorption is not exactly understood; however, there are two main methods. The first method is passive where ions flow into the roots, usually driven by a concentration gradient. The second method is active where the plant has to expend energy to take in ions from the water. The plants obtain this energy from the process called “respiration” (Jones, 1997). This is important because if the plant roots cannot obtain enough oxygen, they will essentially starve to death. Packing the dirt too tightly, overwatering, or high temperatures, which lower the solubility of oxygen in water, may also lead to starvation.

Hydroponics replaces the functions of soil in traditional farming. Soil is a combination of inorganic and organic material. The organic material is called humus and is very important in soil fertility because it acts as a reservoir of essential nutrients and minerals, especially nitrogen. There are four major functions of soil, which include acting as a reservoir for minerals and nutrients, supplying water to the plant, supporting the plant root system, and supplying the plant with oxygen. Hydroponics can replace soil by providing the plant with these needs. An inert medium can be used to support the plant root system or the plant stem can simply be supported by itself. Essential nutrients and minerals can be readily dissolved in the water for plant uptake and oxygen can be supplied using an air bubbler or having a large surface area to volume ratio for the nutrient solution (Resh, 1997).

THE NUTRIENT SOLUTION

One way of supplying nutrient solution is by purchasing individual solid fertilizer salts. The salts must be dissolved in water using the correct concentrations, which requires knowledge of the nutritional needs of plants, but allows for the creation of nutrient solutions specific to each plant species. This option also allows nutrient deficiencies or toxicities to be corrected more easily (Food and Agricultural Organization [FAO], 1993). Instead of combining individual minerals for the solution, a blend of solid salts can be used. Also, premixed, highly concentrated nutrient solution can be used. The solution contains the correct balance of nutrients, but must be diluted before use. These premixed nutrient solutions are mostly marketed towards small home garden projects.

Nutrient solution can also be made from locally available resources. The nutrients can consist of compost, manure, worm castings, wood and bone ashes, bat guano, seaweed, and iron. The necessary nutrition can be extracted from the sources and mixed with water to produce an appropriate nutrient solution (Bradley, 2000b; Marulanda, 1993).

HYDROPONICS VS. TRADITIONAL FARMING

Hydroponic farming offers many advantages when compared to conventional farming. One of the main advantages is that crops can be grown in places with barren or contaminated land. Hydroponically grown plants are also more resistant to water with a high salt content. Another advantage includes not having insects, animals, and diseases such as fungi already present in the growing medium. Labor intensive work such as tilling, cultivating, fumigation, and watering is not required for hydroponic farming (Jones, 1997). If the system is automated using pumps or even computers, labor costs will decrease dramatically.

Hydroponic systems are very efficient. In general, hydroponic plants only use one-tenth of the amount of water used by plants grown in soil because in traditional farming a majority of the water passes through the root layer quickly. The nutrient solution, required for hydroponic farming, only contains 25% of the amount of essential elements found in solid fertilizers. Since plants do not have to compete for surrounding soil space for nutrient reserves, more plants can be grown using less space in a hydroponic system. Spacing is only limited by the amount of available light. Plants also grow much faster and bigger in hydroponic systems. Therefore, hydroponic systems have higher yields per unit area when compared to traditional farming (Turner, 2008).

The main disadvantage of hydroponic systems is that the initial startup cost is rather high. Also, diseases in hydroponic systems can spread very quickly to all beds sharing the same nutrient tank so daily inspection is required (Resh, 1997). Some types of hydroponic systems also require a continuous and reliable power supply, as plant roots can dry out quickly if pumps or sprays fail. Many people assume that hydroponic systems require a lot of scientific knowledge; however, the process is actually very simple and pre-mixed nutrient solutions can be purchased. In addition, higher yields and less intensive labor can make hydroponic systems very marketable (Turner, 2008).

TYPES OF HYDROPONIC TECHNIQUES

There are many different hydroponic techniques used throughout the world. Four of the main types are: nutrient film technique, dynamic root floating technique, water culture technique, and ebb and flow method. The accompanying diagrams for each system can be found in Figures 5-9.

The nutrient film technique (NFT), shown in Figure 5, is one of the most popular systems. Channels are built out of plastic or wood and are lined with polyethylene plastic. A pump is used to circulate water throughout the channel. Plants are suspended above solution with the roots dangling down into the solution. The channels are slightly sloped and the water is collected and reused by pumping it back to the holding tank. Plants with large root systems that can effectively reach down into the water can be grown using this technique (Turner, 2008). Occasionally, overgrown roots can block the channel and water must be filtered for debris before returning to the holding tank (Court, 1998).



Figure 5: Nutrient Film Technique
Source: www.dbcourt.co.uk/hydroponics

The dynamic root floating technique (DRFT) is a hybrid of several hydroponic systems. In Taiwan, The Taichung District Agricultural Improvement Station developed the DRFT in

1986. A diagram of the DRFT system is shown in Figure 6. Nutrient solution is pumped through one end and allowed to circulate through all the channels before being collected back into the tank reservoir. Instead of a continuously circulating nutrient solution system like in the NFT, the water pump is constantly turned on and off to alter the depth of the water. Alternatively, the pump can remain on at all times and a drainage system can be installed to vary the depth. One feature of the DRFT is the concave panels underneath the floating boards, which is shown in Figure 7. This extra space allows roots called “aeroroots” to grow above the nutrient solution and therefore receive more oxygen. Also, various techniques are used to control the temperature of the nutrient solution. When temperatures reach above 30⁰C, semi-transparent polyethylene sheets are hung over the roof to block out some sunlight. Additionally, the DRFT channels are lined with insulating material to impede heat transfer from the immediate surroundings. The main advantage of the DRFT is that it can maintain the temperature of the nutrient solution. Since oxygen is less soluble in warm water, the DRFT is well-suited for hydroponic farming in tropical and subtropical climates such as those found in Thailand (Kao, 1991).

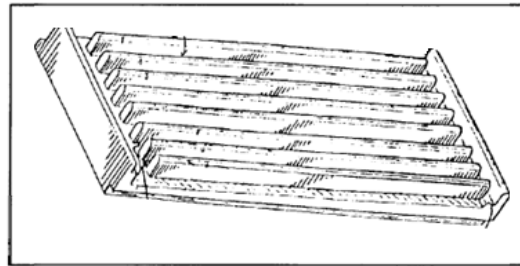

Figure 6: Ridged Culture Bed of a DRFT System
Source: Kao T, 1999

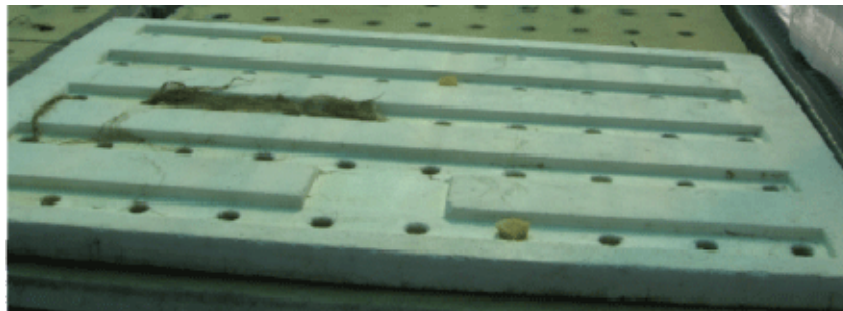

Figure 7: Concave Panels under Styrofoam in DRFT System

In the water culture technique, plants are supported on top of the nutrient solution as shown in Figure 8. This differs from the NFT and the DRFT systems because the roots hang freely into the nutrient solution. Root aeration can be a major problem when water is left to stand, so an air bubbler can be used to oxygenate the water. Alternately, pumps can be used to circulate the water and baffles located at the end of each bed will oxygenate the water as it returns to the reservoir. Roots should remain in complete darkness to ward off the growth of nutrient-consuming algae. The plant stems are supported on trays that float on top of the solution (Resh, 1997). This method is effective for plants such as lettuce, but not for larger plants or those that take a long time to grow such as tomatoes or cucumbers (Court, 1998).

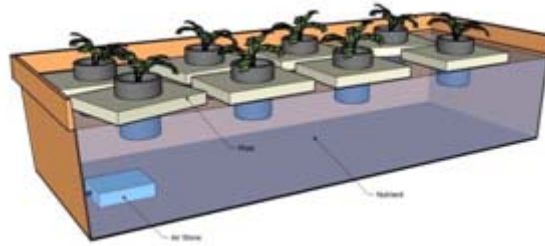

Figure 8: Water Culture Method
Source: www.dbcourt.co.uk/hydroponics

In the ebb and flow method, shown below in Figure 9, water is pumped into the tank and then allowed to gradually drain. This differs from the water culture method because as the water drains, the roots are exposed and receive more oxygen. Also, cycling the water ensures that the water is less stagnate and will contain more oxygen. Careful attention must be given to the pumps because if the pumps fail, the plant roots can dry out quickly, especially in hot climates (Court, 1998). Ebb and flow systems work best with small plants such as basil or parsley (Turner, 2008).



Figure 9: Ebb and Flow System
Source: www.dbcourt.co.uk/hydroponics

BUILDING AND OPERATING HYDROPONIC SYSTEMS IN LOW RESOURCE AREAS

In a low resource area, it is advantageous to use simplified hydroponics because it is low cost, uses commonly available resources, and does not require much technical expertise. Peggy Bradley, César Marulanda, and Juan Izquierdo, experts on hydroponics, have written several publications on implementing simplified hydroponics in developing countries. Bradley and Marulanda suggest that simplified hydroponic systems require small startup costs, which can make hydroponics affordable for a wider range of people. Also, materials such as fish aquarium tanks, ceramic pots, and aluminum cans can be used. In addition, other commonly used materials include custom made plastic channels, Styrofoam, wood lined with polyethylene plastic, and bed channels dug into the ground and cemented with concrete or lined with polyethylene plastic. Generally simplified hydroponic systems require less technical expertise than other methods, which makes the maintenance and operation of the system less complicated and easier to perform.

Marulanda also suggests that when selecting the type of hydroponic system to use, factors such as resources, budget, local climate, and operators' experience should be considered. The availability of resources, like electricity, will affect the choice of the hydroponic system, as well as the amount of money that is available to construct and operate the system. Also, the

climate of the area in which the hydroponic system will be located should be considered in order to increase the likelihood that the proper type of system and materials are chosen. (Marulanda, 1993). Lastly, the technical expertise of the operator will affect the type of hydroponic system selected.

Marulanda and Izquierdo state that it is common to set up the system with many separate growing beds. The platform of these beds can be constructed of recycled wood pallets. If pallets are unavailable, the beds can be constructed from any available lumber, bamboo, or other building materials and covered in a thick black plastic that will hold various media. These wooden beds are then elevated about three to four feet off the ground which reduces infestation of ground-based pests, makes routine maintenance easier, and allows for runoff water to be collected and reused (Marulanda and Izquierdo, 1993). Bradley and Marulanda have found that a simplified system consisting of 18 two square-meter growing beds can produce approximately nine to ten pounds of vegetables per day, which is enough to provide 25% of a family of four's dietary requirement (Bradley and Marulanda, 2000a).

Once the system is ready to be used, the seeds need to mature and grow roots. This process is known as germination and requires the proper amount of humidity, airflow, and light (Bradley and Marulanda, 2000c). To begin the process, the seeds should be planted in a substrate-based system. When the roots are long enough, they can be transplanted to another bed where they will have more space to grow and develop until harvest (Marulanda and Izquierdo, 1993).

The hydroponic beds need to be properly maintained in order to keep the system running efficiently. One area of maintenance is pruning, as some plants will grow out of control. For example, cucumbers, squashes, and other vine crops can grow as much as one foot per day. Once the plant is pruned, the size of the vegetables will increase because the plant will put more energy into producing the desired vegetable and less into the excess vegetation (Bradley and Marulanda, 2000c).

Another maintenance issue is pest control. There are many different types of pests that can adversely affect a hydroponic system. These pests can be pathogens, insects, animals, pets, or even people (Marulanda and Izquierdo, 1993). Pests can lead to poor results and can cause frustration (Bradley and Marulanda, 2000c). It is important to focus more on the prevention of pests than on the elimination. Marulanda and Izquierdo suggest that physical barriers, sprays, and traps can control bugs and different sprays can control and prevent certain pathogens. Since insects prefer undisturbed places, the most effective way of controlling pests is the frequent inspection of the vegetables (Marulanda and Izquierdo, 1993).

The more efficient systems will have a continued harvest because if timed correctly, the system can be a year-round source of fresh vegetables that can be harvested daily. There are three different ways to harvest vegetables: *whole harvest*, *fruit harvest*, and *partial harvest plants*. A vegetable where the entire plant is harvested is a whole harvest plant. A vegetable that produces fruit is a fruit harvest plant, which can be harvested frequently. Lastly, there are

partial harvest plants, where some of the produce can be taken without damaging the plant. An example of a partial harvest plant is a lettuce plant that is harvested by cutting off the outside leaves and allowing the center to continue to grow. Compared to a plant pulled in a whole harvest, a partial harvest plant can produce eight times the number of leaves. This shows that choosing the most suitable harvesting technique is important in order to maximize plant yield (Bradley and Marulanda, 2000c).

Simplified hydroponics is an example of how an alternative farming technique may be an effective way of maximizing farming efficiency. In agriculturally-based areas it is important for people to know of these alternative farming techniques. If alternative farming techniques, such as hydroponics, are introduced to students through their school curricula, they will learn how to utilize techniques that may be more effective than traditional farming.

HYDROPONICS IN EDUCATION

Hydroponic farming can be taught in the classroom not only to promote and expand its use, but also to be applied as an educational tool. Case studies show that hydroponic systems have been used as learning tool at various education levels from kindergarten to graduate school. While students can read about these topics in a textbook, operating a hydroponic system provides students with a visual and hands-on learning experience. Students may become more engaged when they are given the responsibility of growing their own plants. A benefit of a curriculum based upon hydroponics is that it can cover a variety of topics including science, math, history, and business skills. The following case studies are examples of successful implementations of educational hydroponics at different education levels.

CASE STUDY 1: URUGUAY KINDERGARTEN HYDROPONIC EDUCATION PROGRAM

In 2004, M.C. Stajano, president of the Uruguayan Hydroponics Society and the principal of AquaFood, described how hydroponics was used as an educational tool to stimulate learning among the children at the Kindergarten of the British Schools, in Uruguay. Traditional soil gardening was first used in the school as an education tool, but was unsuccessful due to limited space, the large number of children participating, and complex watering. In addition, the crop was not worth harvesting after the effort made by such a big group. In order to understand other agricultural methods, the teachers attended AquaFood, a program where teachers and children are taught through visuals and hands-on experiences about different agricultural methods including hydroponics. Following this program, in 1999, the teachers decided to use hydroponics as a teaching aid in the school.

Stajano explains that hydroponics does not require a large amount of space and that students, even in large numbers, can individually and directly participate. Other advantages of using hydroponics versus traditional farming are that the students are able to observe the plant's roots while still keeping the plant in its environment. Also, the plants grow fast enough so that the children stay interested and engaged. By the end of the project, the teachers wanted

the children to understand the life cycle and functions of the plants, to develop healthy eating habits and teamwork abilities, and to learn respect and values for nature. The main elements of the unit on plants covered the different parts of the plant, growing requirements, functions, life cycle, and edible parts of the plant.

Stajano describes how each student was given a plant and was able to monitor its growth with the help of a teacher. The students were also responsible for making sure that their containers had enough nutrient solution and could refill their containers with the solution made by the teacher. In addition, mid-way through the program, the school hosted a discussion with the parents, family, and members of the school about how the experience was related to the education of the children. Photographs and discussions were used to help the families understand what their child was involved in and what they were learning. Once the plants were harvested, the children could sample all the various vegetables to see which ones they liked. They were able to experience the taste of new vegetables, expand their range of nutrition, and take the rest of the vegetables home to share with their families.

From this program, the children were able to directly observe plant development and understand the various parts and functions of plants. The children were also able to develop their healthy eating habits, and increase their self-esteem by growing their own vegetables. According to Stajano, it is seen from this case study that hydroponics can be a valuable tool used in education as it promotes interactive learning (Stajano, 2004).

CASE STUDY 2: ALASKAN HIGH SCHOOL HYDROPONIC EDUCATIONAL PROGRAM

In 2008 in Fairbanks, Alaska, a Future Farmers of America (FFA) advisor, Marilyn Krause, and University of Alaska Fairbanks horticulture professors and researchers, Jeff Werner and Meriam Karlsson, started a project involving the educational use of hydroponic farming. Krause and Karlsson have conducted research on hydroponics while Werner has had previous experience in commercial hydroponics projects. Krause, Werner, and Karlsson advised nine high school students who helped with the project by working 32 hours per week to maintain the system. The project was conducted as part of an educational program that partners schools with local businesses in the farming industry. Programs such as these have become increasingly popular due to recent challenging growing seasons and rising energy and food prices. Environmental conditions in Alaska limit the area's ability to produce food on a regular basis, which is why greenhouse hydroponics was introduced, according to Krause.

The system was situated in a greenhouse and used several different types of hydroponic systems including a drip system, deep-water culture, and nutrient film technique, requiring the students to learn how to operate each one. Krause explained that the students were able to see the differences between the types of systems and conduct horticulture experiments. Being able to experiment with different variables was an effective way to keep the students active and interested. Another aspect of the students' jobs was to give public tours of the system.

Vegetables grown using the hydroponic system were served at a local restaurant. The students successfully grew a variety of vegetables including tomatoes, cucumbers, strawberries, and lettuce. In addition to benefiting the local community by providing food, the program served as an innovative learning tool in which the students were able to experiment with many different types of systems and plants.

Krause suggested that while enhancing their background in agriculture, the students were also able to improve their management, marketing, and communication skills. In terms of management skills, students with more experience in farming were given more responsibility with scheduling and overall maintenance. The students gained marketing skills because they were in charge of selling the vegetables to the local restaurant as well as advertising the greenhouse to the public. They improved their communication skills by giving tours to the public and explaining the process of hydroponics.

This program illustrates how educational hydroponics can provide many benefits to the students involved. The students were able to expand their scientific knowledge and gain some practical business skills in the process. These skills would help them once they enter the work force, especially if they are considering a career in agriculture. Krause noted that allowing the students to create their own experiments makes them more likely to be interested and motivated to work with the hydroponic system. This case study suggests that it is effective to have the students as active as possible in the operation of the system because it will help them better understand the overall process (Goff, 2008).

MSU SIFE TEAM AND THEIR HYDROPONIC SYSTEM

Another group that is investigating the use of educational hydroponics is the Mahasarakham University chapter of Students in Free Enterprise (MSU SIFE). SIFE is a non-profit network of business executives, educators, and students who create and perform community outreach projects. SIFE teams are established on university campuses around the world and there are currently active chapters in 40 countries. Their mission is “[t]o provide college and university students the best opportunity to make a difference and to develop leadership, teamwork and communication skills through learning, practicing and teaching the principles of free enterprise” (SIFE, 2008). SIFE teams use their knowledge of micro-enterprise to educate communities so that they can become more self-sufficient. In an attempt to improve the economic conditions of the rural villages in the area, the MSU SIFE team designed and constructed a hydroponic system in 2008 with the produce serving as both a source of food and income. Although the system was destroyed by a storm later that year, hydroponic farming remains a promising agricultural option for Northeast Thailand since it allows for the production of high quality, high value agricultural products regardless of the soil conditions.

As mentioned previously, the MSU SIFE team constructed a hydroponic system in the village of Ban Ma Kok. The hydroponic system was designed to produce vegetables for the school lunch as well as provide additional income for the community. The system was built using the dynamic root floating technique (DRFT), which is described earlier in the chapter. Figure

10 shows the plants floating on top of the nutrient-rich water. The MSU SIFE team constructed the pillars and support structure out of eucalyptus wood. They used plywood and Styrofoam to create the channels shown in Figure 11, that were lined with polyethylene plastic to make them water resistant; this can be seen in Figure 12. The roof of the system was covered with semi-transparent plastic sheeting to protect the system from rainwater while the sides of the system were covered by mosquito nets to keep out pests as shown in Figure 13. Other materials used in the construction of the system include nails, glue, rubber tubing, and Styrofoam.

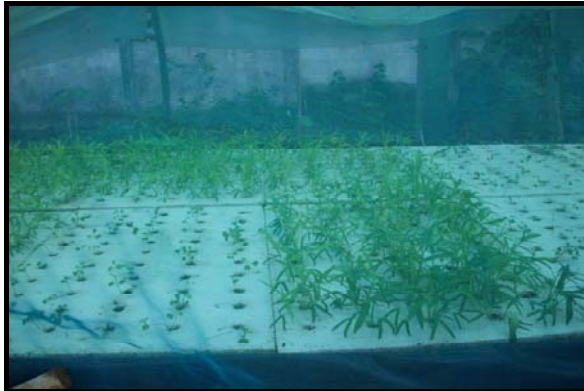

Figure 10: Vegetables in Styrofoam Sheets in MSU SIFE Team Hydroponic System (Left)
 Figure 11: Channels Constructed Using Plywood in MSU SIFE Team Hydroponic System (Right)
 Source: Kid-Arn (2008)



Figure 12: Lining of the Channels with Polyethylene Plastic in the MSU SIFE Team Hydroponic System (Left)
 Figure 13: Plastic Sheeting for Roof and Mosquito Nets on the Sides in the MSU SIFE Team Hydroponic System (Right)
 Source: Kid-Arn (2008)

While in Ban Ma Kok, the MSU SIFE team educated the students on the hydroponic system by holding a series of educational events. The students were encouraged to participate in this project by helping build and maintain the system. Due to the combined efforts of the MSU SIFE team and the students of the village of Ban Ma Kok, they were able to grow and sell some vegetables (SIFE Mahasarakham University Original Packet).

Although the MSU SIFE team was able to successfully grow and sell some vegetables, they eventually encountered a number of major problems and the project was unable to continue. One problem that the team encountered once the system was running was the effect of the

high temperatures on the plants. In Northeast Thailand, the temperatures can be very high causing the plants to wilt and die. The MSU SIFE team believed that the plastic sheeting used on the roof was increasing the temperature in the hydroponic system. In order to solve this problem, they placed a temperature reducing material over the roof. Unfortunately, this material blocked too much sunlight and reduced the growth of the vegetables.

After a severe storm passed through the village and the hydroponic system was destroyed the SIFE team was able to identify a major design problem with the roof of the system shown in Figure 13 above. The pitched roof was constructed using eucalyptus wood and plastic. The storm produced a large amount of rainwater that was unable to properly drain off the roof causing the water to collect on the plastic and rip it. The water fell directly on top of the vegetables and they were destroyed (Kid-Arn, 2008).

The cost of building the system was very high which made it difficult for the system to be profitable for the school. While the estimated cost for an industry standard hydroponic system is about 50,000 Baht (1,400 USD), the MSU team only spent about 5,000 Baht (140 USD) in construction materials. Although the team decreased the construction cost, the money made from selling the vegetables was not enough to recoup the cost of the system in a reasonable amount of time. (Kid-Arn, 2008).

The last major challenge with this project was that the school children were not fully engaged and interested in the project. According to the SIFE team, this was due in part to the fact that the system was not properly integrated into the teaching curriculum and student activities. The students were not rewarded or graded for the work they put into the system. Thus, the students lacked motivation and concern to maintain the system, causing it to be neglected.

Although there were many complications with this system, there are ways the system can be improved. One improvement is to redesign the system's roof to better satisfy the environmental conditions of the area. The materials for the system should be as inexpensive as possible to reduce startup costs. In addition, if the hydroponic system was properly integrated into the curriculum, it would be more likely to be successful. With these lessons learned, the MSU SIFE team decided to implement a pilot program at the Mahasarakham University Demonstration School. The SIFE team has asked for our help with designing, constructing, and integrating a new hydroponic system into the agricultural curriculum at the MSU Demonstration School. If this program is proven successful, SIFE intends to use the hydroponic system as a platform to promote the use of hydroponics in other areas of Thailand.

METHODOLOGY

The goal of our project was to design and construct a hydroponic system for the Maharakham University Demonstration School that could be integrated into the agricultural curriculum while introducing business skills to the students. Our team established five objectives that helped us achieve this goal:

1. Understand the needs and goals of the MSU SIFE team and assess the previous hydroponic system.
2. Design the hydroponic system.
3. Construct the selected hydroponic system.
4. Develop educational materials on agriculture and the use of hydroponics.
5. Recommend interactive and engaging activities for the students introducing entrepreneurial skills.

In this chapter, for each objective we will describe the purpose, information needed, how we obtained this information, and how it was used to achieve our goal.

OBJECTIVE 1: UNDERSTAND THE NEEDS AND GOALS OF THE MSU SIFE TEAM AND ASSESS THE PREVIOUS HYDROPONIC SYSTEM

We wanted to identify the needs, goals, and constraints of the MSU SIFE team and the strengths and weaknesses of the previous hydroponic system as a basis for defining user requirements for the new hydroponic system. We intended to learn about the following topics:

- The design of the system, the materials used, and reasons why these were chosen;
- What the MSU SIFE team would have done differently with the project;
- The startup cost of the system;
- Which vegetables grew well, which didn't, and the price they sold for at the market; and,
- The strengths and weaknesses of the previous hydroponic system.

We gathered this information by corresponding through emails with the MSU SIFE team and conducting a number of interviews with Mr. Andrew Cottam, the SIFE team advisor and also the sponsor of our project. We communicated with student members of the MSU SIFE team through email prior to our arrival in Thailand (the questions included in the email are given in Appendix A). This was the easiest way for us to communicate with the team before we arrived in Bangkok and it helped to clarify details on our project. We would have preferred to have a conference call with the MSU SIFE students and our sponsor; however, the mutual language barrier prevented this type of communication from being effective and feasible. If this was possible, we could have asked more questions that were prompted from their answers, rather than only asking a predetermined set of questions. This may have given us more information earlier into our project.

Once we arrived in Maharakham, we conducted interviews with Mr. Andrew Cottam. We chose in-depth, qualitative, and semi-structured because we wanted to foster informal discussions with a combination of questions and prompts. Also, this style of interview allowed us to ask additional questions in order to clarify a response or obtain more details. Our purpose was to obtain a first-hand account of his experiences with the past system, so that we could identify the needs and constraints of the MSU SIFE team and the strengths and weaknesses of the previous system. A complete list of the interview questions for the Mr. Andrew Cottam can be seen in Appendix A. In addition to these interviews, we were able to visit the previous hydroponic system in the village in order to see the system and confirm what we learned about it from the SIFE team.

Although these interviews were helpful, it would also have been beneficial to interview the MSU SIFE students in person. If we had interviewed them, we would have been able to understand their opinions and experiences with the previous system. Unfortunately, due to time constraints and the MSU SIFE students' commitments to class and homework, we were not able to conduct these interviews.

Once this information was gathered, we used it to define the design criteria for the hydroponic system. In order to do this, we created a list of user requirements formed from the needs and goals of the MSU SIFE team. We used these requirements along with the information we gained from the previous system and our background research to develop a set of design criteria. A representation of the process to develop the design criteria can be shown below in Figure 14. With the design criteria established, we began the design process for the hydroponic system.

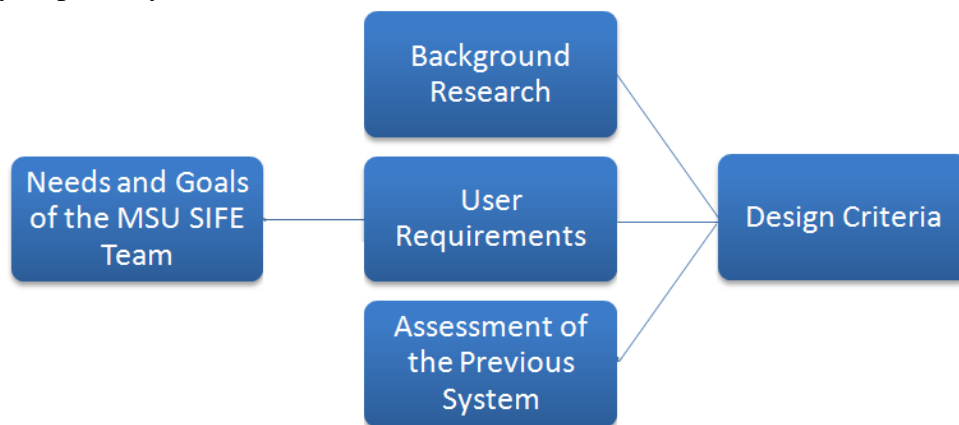

Figure 14: Development of Design Criteria

OBJECTIVE 2: DESIGN THE HYDROPONIC SYSTEM

We designed the hydroponic system by using the design criteria. We were able to start the design process by gathering the following information:

- What hydroponic technique was used in the previous hydroponic system;
- What hydroponic projects are currently active in Thailand;
- What vegetables are primarily grown in Thai hydroponic systems; and,

- What design criteria are of highest importance?

In order to create preliminary designs of the structure, we determined what type of hydroponic technique to use. The interview with the MSU SIFE team helped us understand the type of hydroponic technique that was used previously and how successful it was. In addition, our group used information gathered from an interview with two hydroponic experts from the Food and Agriculture Organization (FAO), as well as visits to two hydroponic farms. This interview was in-depth, qualitative, and semi-structured as described in Objective 1. A complete list of the questions can be seen in Appendix A.

We also examined the different types of hydroponic systems that were located at the ACK Hydro Farm, the largest commercial hydroponic farm in Thailand. The FAO recommended that we visit this farm in order to gain more information for our project. Even though many of their systems utilized expensive technology that was not feasible for our project, we learned how the different hydroponic systems worked. In addition, we visited the local hydroponic demonstration farm that was supported by the government in Mahasarakham. Through this visit, we learned how their hydroponic systems worked and obtained detailed procedures for maintenance as well as specifications on the dimensions of the system. These visits were a helpful way to collect information as we could see the systems for ourselves and also ask the operators questions. Through research on different types of hydroponic systems and information gathered from the interviews and visits, we identified what type of hydroponic technique to use.

We used a pair-wise comparison chart to identify the most important design criteria for the overall hydroponic system. An example of a pair-wise comparison chart is shown below in Figure 15. In this method, competing design criteria are evaluated against each other and rated in terms of importance (Dym & Little, 2004). The ratings from the pair-wise comparison chart gave our team a clearer idea on which design criteria to focus on when developing the designs. One limitation of using a pair-wise comparison chart is its lack of accuracy. Since design criteria can only be scored using three possible choices of 0, 1/2, or 1, human error or bias can significantly skew results. In a pair-wise comparison chart, small differences in ratings should not be considered. Therefore, our team clustered the design criteria into groups with similar rankings. Using the pair-wise comparison chart, we identified the important objectives of the hydroponic system. We developed multiple preliminary designs of the frame based on several popular types of roofing structures. To select the most suitable design, we determined which frame best satisfied the design criteria while remaining within the design constraints.

	Objective 1	Objective 2	Objective 3	Total
Objective 1	X	1	1	2
Objective 2	0	X	1/2	0.5
Objective 3	0	1/2	X	0.5

Figure 15: Generic Pair-Wise Comparison Chart
Source: Dym & Little (2004)

We chose the materials for the hydroponic system based on how well they satisfied the design criteria. We discussed with our sponsor and another professor at MSU about the materials to build the hydroponic system. This information, along with the information gathered about simplified hydroponics, provided us with information on how well the materials met the design criteria. Thus, we were able to choose the materials for the hydroponic system.

OBJECTIVE 3: CONSTRUCT THE SELECTED HYDROPONIC SYSTEM

We constructed the hydroponic system to help the SIFE team achieve their goal of using hydroponics as an educational tool. Being able to present the SIFE team with a physical system increased the likelihood of SIFE implementing the system into the MSU Demonstration School's curriculum. In order to complete the construction, we sought to gather the following information:

- Where will the materials be purchased;
- Who will be fabricating the frame;
- Where will the frame be fabricated; and,
- Where will hydroponic system be located?

Working with our sponsor and other professors at the university, we selected a material supplier located in Mahasarakham to buy materials for the frame. Through a connection between a faculty member and the supplier, we received a discount on our purchase. The supplier agreed to cut the material to length before purchase, saving us time and effort. We performed a final check of all lengths to confirm we had the correct materials required to fabricate the frame. When purchasing materials we were assisted by a professor who spoke Thai and had knowledge of the area.

With the materials gathered, we aimed to find the most efficient way to assemble the frame. Our sponsor informed us that there was a fabricator affiliated with the university. We decided to work with this fabricator because it was convenient to construct the frame on campus and he was experienced in this type of work. Also, working with a university employee was less expensive than hiring an outside fabricator and it allowed us to work on other aspects of the project simultaneously. We created a simple construction manual for the fabricator, included in Appendix B, and described the process to him in order to ensure that he understood the design. We chose the steps for fabrication in an order that would minimize errors and time needed for construction. As a result, the fabricator was able to construct the frame on schedule.

While the frame was being fabricated, we continued to work on gathering materials for rest of the hydroponic system. Due to the variety of materials required, we had to purchase the components of the hydroponic system at several stores. This delayed the construction of the system because of the limited availability of translators and proper transportation. We required a vehicle capable of transporting large materials and a translator to assist us with the

purchases. Our sponsor provided us with his truck for transportation and Thai speaking professors from Maharakham University helped us communicate with the shop owners. Finding a time where both of these needs were met was difficult. We also gathered the salvageable materials from the previous system to save money.

With all the materials gathered, a location for the hydroponic system was determined. The school was unable to prepare the final site for the hydroponic system in time for us to begin construction there. A nearby location had adequate space for the system and the Demonstration School notified us that we would begin construction there.

OBJECTIVE 4: DEVELOP EDUCATIONAL MATERIALS ON AGRICULTURE AND THE USE OF HYDROPONICS

As mentioned earlier, the MSU SIFE team found that the hydroponic system in the village of Ban Ma Kok was neglected by the students at the school due to a lack of interest in the project. Case studies suggest that when hydroponics is integrated into the science and agricultural curriculum, students are more likely to be engaged in academic activities. Therefore, if the students are engaged in the activities involving the hydroponic system it may increase their dedication to the system. To improve the chances that the hydroponic system would be successfully integrated into the agricultural curriculum at the Maharakham University Demonstration School, we wanted to involve the science teacher as much as possible in the creation of the teaching manual. We worked closely with the teacher and considered his input so that he would be more likely to use the manual in his teaching.

Our group wanted to learn more about the overall structure of the teacher's classroom, the current curriculum on hydroponics and agriculture, and what the teacher thought about our ideas on teaching hydroponics as a basis to create a teaching manual that is intended to help integrate the hydroponic system into the agricultural curriculum. We sought to learn the following information:

- The topics covered in the current agricultural curriculum;
- The different class sizes and grade levels of the students;
- The amount of time the teacher is able to devote to teaching agriculture and hydroponics;
- What the teacher would like his students to learn from using the hydroponic system;
- The kind of materials we can give to the teacher that will help him integrate the hydroponic system and educational information into his curriculum; and,
- The teacher's opinion on the content of the teaching manual.

We collected this information by conducting several interviews with the teacher, which were in-depth, qualitative, and semi-structured. The interview questions and summaries can be found in Appendix A. From the information gathered from our first interview, we created an outline for the teaching manual. We met with the teacher to review the outline and receive his

opinions on our ideas. By combining the teacher's input with our research of educational hydroponics, we were able to devise a list of guidelines for the teaching manual. We used the guidelines to create a manual that was intended to help integrate the hydroponic system into the agricultural curriculum. Since a translator was used for the interviews, our team took into account that our questions or the teacher's answers may have been misinterpreted, which could have affected the information we gathered. In addition, we wrote the manual in English and the SIFE team agreed to translate the manual into Thai before the start of the semester in June 2009. Similar to the interviews, there is a possibility that translating the teaching manual may introduce errors or confusion, which may cause it to lose some of its educational value. Given this limitation, we were cautious when creating the manual.

OBJECTIVE 5: RECOMMEND INTERACTIVE AND ENGAGING ACTIVITIES FOR THE STUDENTS INTRODUCING ENTREPRENEURIAL SKILLS

We created a recommendation for interactive and engaging business activities involving the hydroponic system for the MSU SIFE team to carry out with the students. The purpose for this recommendation was to allow the SIFE team to use both the activities and the hydroponic system to fulfill their mission statement of teaching the principles of free enterprise. Similar to the development of the teaching manual, we sought to involve SIFE as much as possible with the creation of entrepreneurial activities so that they will be more enthusiastic about its implementation.

In order to create a recommendation that would be useful to SIFE and would be fun and engaging, we gathered information on the following:

- What important topics and specific business skills did the SIFE team want to incorporate into the business activities;
- How much time the SIFE team would be able to devote to explaining the activities and working with the kids; and,
- What types of activities the SIFE team and the science teacher believed the students would enjoy the most?

We obtained a majority of this information from SIFE through discussions with the team during our stay in Mahasarakham. However, email correspondence was used as a means of communication once we returned to Bangkok. The desired learning outcomes and availability of the SIFE team helped us to determine the structure and nature of the activities.

To create interactive and engaging activities, we spoke with both the SIFE team and the science teacher at the school to find out which types of activities they believed the students would enjoy the most. We gathered this information through discussions with the SIFE team and through interviews with the school teacher. The opinions of the SIFE team were useful because most of them were students in the Thai education system. The teacher's input was also helpful because he works with the students on a daily basis and knows their interests. Ideally, we would have spoken to the students to get their suggestions for fun activities.

However, due to time constraints and language barriers, we were unable to hear the students' input.

In order to create the recommendation, we identified guidelines for the activities to follow. From the information gathered from the case studies on hydroponics in education and the input from the SIFE team and the teacher, we brainstormed ideas for different types of activities involving the hydroponic system that were both fun and educational. We wanted to review these ideas with the SIFE team before continuing with the design of the activities, but time limitations did not allow us to do so. We used our ideas, information from the case studies, and information gathered from discussions with the SIFE team to give them a recommendation for engaging activities for the MSU Demonstration School students. This recommendation will serve as a foundation for the SIFE team to create their own activities to implement at the school.

A HYDROPONIC SYSTEM FOR THE MSU DEMONSTRATION SCHOOL

From the information gathered through our interviews and assessment of the previous system, we designed and constructed a hydroponic system for the MSU Demonstration School. This chapter begins with a presentation of the design criteria that we developed for the system and reasons why we chose them. Next, we discuss the type of hydroponic technique that we chose for the system. We then present the preliminary designs considered for the frame of the system, including a description of the advantages of the chosen design. The final section of this chapter provides a description of the materials chosen to build the system.

DESIGN CRITERIA FOR THE HYDROPONIC SYSTEM

We created design criteria using the user requirements, successes and failures of the previous hydroponic system, and research on existing hydroponic systems. The criteria identified were:

Durable

A durable structure was identified as a requirement for the system because of the previous system's structural failure. Through our correspondence with SIFE and visiting the previous system, we determined that the system's roof design was not robust enough to withstand the local weather conditions. The roof failed during a storm and was a major reason the project was unable to continue.

Modular

One of the MSU SIFE team's goals for their new project was to have a hydroponic system that could be easily transported. This would allow them to move the system to another school and try to implement it there if the system was unsuccessful.

Replicable

Another goal of the MSU SIFE team was to be able to replicate the system at other schools and villages if it was successful. This fits within SIFE's mission to promote sustainable business practices and work towards self-sufficient communities. In order for the SIFE team to have the option of replicating the system, the materials used in construction should be locally available. Using local materials makes replacing materials easier and minimizes delivery services.

Easy to operate and maintain

The system will be operated and maintained by the agricultural teacher and his students at the MSU Demonstration School. Since many hydroponic techniques require advanced technical equipment and experience, a simple hydroponic technique should be chosen. The teacher should be able to understand how to operate and maintain the hydroponic system with the help of the MSU SIFE students and by using an operation manual. Since

we wanted the system to be used by the teacher and students, we chose one of the design criteria to be ease of operation and maintenance.

Suitable for healthy vegetable growth

The system should be able to withstand the climate of the region and produce healthy vegetables. Some problems that can arise from the climate in Thailand are intense heat and periods of heavy rain and drought. Therefore, in order for the hydroponic system to be successful, the system should produce healthy vegetable growth under the conditions of the region.

Low cost

The last design criteria we determined for the system was that it should be low cost. The MSU SIFE team was constrained by a budget of 15,000 Baht, so we had to make sure the overall cost of the system was under that figure. Also, in terms of replicating the system, the cost to build the system should be as low as possible while still achieving the required design criteria. By constructing a low cost system, more schools or villages with smaller budgets will be able to invest in a hydroponic system.

We used a pair-wise comparison chart, as mentioned in the methodology, to identify the most important design criteria for the hydroponic system. We determined, by clustering the design criteria into groups that the most important criteria were: durable and suitable for healthy vegetable growth. The complete chart can be seen in Appendix C. Although these were the two most important criteria in making key decisions, we considered the other design criteria as well.

CHOICE OF HYDROPONIC TECHNIQUE

From our knowledge about the previous system and the information gathered from the Food and Agriculture Organization (FAO) and ACK Hydro Farm, we determined that the dynamic root floating technique (DRFT), described in the background chapter, was the most suitable hydroponic technique for the system in Mahasarakham. We learned from the operators at ACK Hydro Farm, located in Bangkok, that hydroponics is not very successful in the Northeast due to the intense heat of the region. The DRFT has several features that manage and reduce heat in the system making it suitable for the climate of the region. One of these features is a tank that can be installed under the system or underground, protecting it from the sun. Also, the volume of the nutrient solution in the channels is larger than other techniques and therefore will remain cooler for a longer period of time. Additional methods, such as temperature reducing material, can be used in combination with the DRFT to reduce the temperature within the system. We also learned from our interview with the FAO that the DRFT was the most cost effective method to be used in rural Thailand in areas such as Mahasarakham. In addition, we found that the previous hydroponic system, created by the SIFE team, used the DRFT and successfully produced vegetables. Since the SIFE team was already familiar with this technique, it would be easier for them to implement the hydroponic system at the Demonstration School. Electricity was available at the school making the DRFT

an appropriate option. We chose to use the DRFT because it is suitable for healthy vegetable growth as it includes features to withstand the intense heat of the region, is cost effective, and was previously used by the MSU SIFE team.

CHOICE OF THE HYDROPONIC SYSTEM FRAME

We considered three roof structures to create the preliminary designs, which were: Quonset, A-frame, and semi-Quonset. These structure types are commonly used to construct greenhouses. The Quonset design, shown in Figure 16, is constructed of PVC pipe supported by reinforcing bars or rebar. The rebar would be placed vertically in the ground in two rows and PVC pipe would be placed over the rebar forming the shape of an arch and connecting to the other side. Polyethylene sheeting is draped over multiple arches creating a tent or small greenhouse over the hydroponic beds. The arch shape allows the rainwater to flow off the roof in order to increase drainage and avoid ripping the plastic.

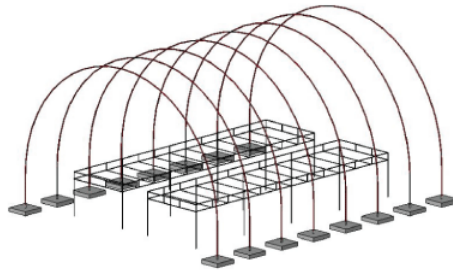

Figure 16: Quonset Frame Design

The second design is an A-frame structure as shown in Figure 17. Like the Quonset arch, the A-frame is a free-standing structure that acts as a greenhouse for the hydroponic system. The A-frame can be easily made from straight segments of PVC or steel, and would require fairly little fabrication except some welding. Polyethylene sheeting is draped over multiple frames and the sharp angles would let rain water flow off the sides. Although the A-frame is rather tall compared to its width, the extra space near the top would allow hot air to rise.

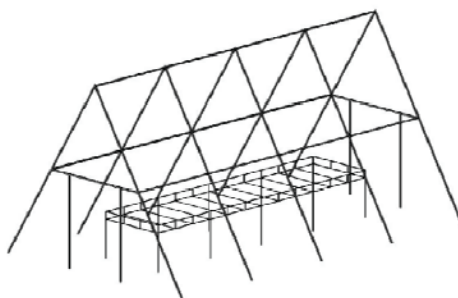

Figure 17: A-Frame Design

The last design is semi-Quonset, made of steel, with an integrated hydroponic bed as shown in Figure 18. This design consists of multiple roof frames connected together through cross braces. The supporting posts between the bed and the roof slope outwards to increase the roof area that covers the hydroponic beds. Polyethylene sheeting is draped over the top and is clipped to the metal structure to protect the system from rain. The lower part of the structure acts as a table that supports the channels. The hydroponic bed is made of plywood and is

fastened to the metal structure with nuts and bolts. The semi-Quonset design consists of a hydroponic bed that measures one and a half meters wide by six meters long and can support and grow approximately 730 plants in one harvest.

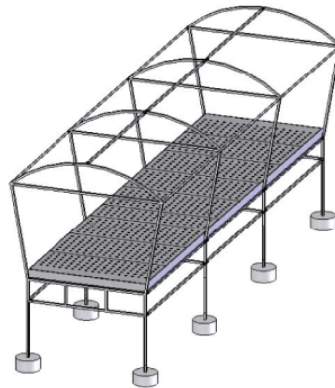

Figure 18: Semi-Quonset Frame Design

We chose the semi-Quonset frame as the design for the hydroponic frame. Compared to the other designs, the semi-Quonset frame best satisfies the design criteria while also being within the budget. The most important design criteria, durable and suitable for healthy vegetable growth, are equally satisfied by all three designs. However, both the Quonset arch and the A-frame structures are difficult to transport. The Quonset arch requires rebar to be permanently placed in the ground and the A-frame structure is large. However, the semi-Quonset design is modular because it can be separated into several pieces, as seen in Figure 19. Since the semi-Quonset design integrates the hydroponic bed into the frame, it saves material and decreases cost, whereas the other two designs separate these two parts. Also, this design uses steel, which is less expensive than PVC, making it more affordable than the Quonset frame. Overall, the semi-Quonset design would be less expensive than the other two designs because it uses fewer materials and is low cost. In addition, the semi-Quonset design is durable because it uses welded steel and concrete footings. It is also made from locally available material and can be constructed by a local fabricator.

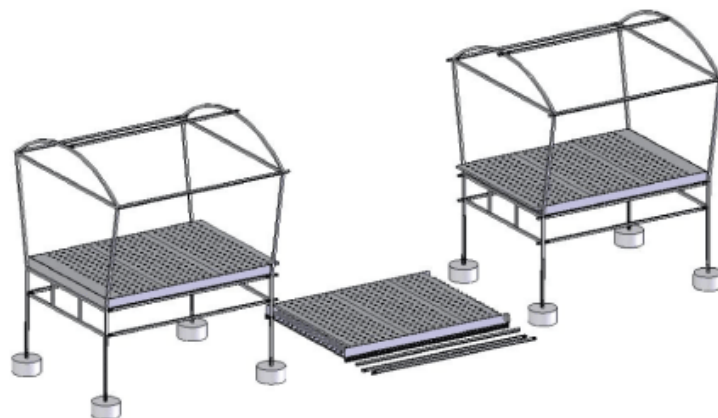

Figure 19: Semi-Quonset Frame Partially Deconstructed for Transportation

MATERIALS TO BUILD THE HYDROPONIC SYSTEM

We chose materials based on the design criteria, constraints, and research on low cost techniques. We chose to use plywood for the construction of the bottom and sidewalls of the hydroponic bed. Plywood is locally available at several construction shops and is a common building material. It is also less expensive and easier to work with than other alternatives, such as sheet metal. We considered salvaging plywood from the previous system; however, due to time constraints and the condition of the plywood we decided to purchase new plywood. Bolts are used to secure the plywood to the cross braces of the frame, which can be removed if the system needs to be transported.

We decided to use Styrofoam to construct the ridges and boards of the DRFT system. Styrofoam can be easily cut to size and it is affordable and durable enough to be used for the ridges or as boards. It is also light enough to float on top of the water, but heavy enough to not blow away with the additional weight of the plants and sponges.

We chose black plastic to line the ridges and channels and semi-transparent plastic for the roof. The black color will absorb any light that may come into the system, therefore reducing the growth of algae. Semi-transparent plastic is transparent enough to allow sunlight into the system, but durable enough to protect the system from wind or rain. The plastic sheeting is low cost, locally available, and can easily be replaced if damaged. Both the liner and the roofing are held down with metal clips and we chose them because they are durable, locally available, and low cost.

We chose to re-use some of the materials from the past system to decrease the cost. The materials we gathered from the previous system were the PVC piping used for the plumbing of the system, mosquito netting, and temperature reducing plastic netting for the roof. Although we obtained these materials from the previous system, they can be found locally and are inexpensive to buy.

We estimated that the hydroponic bed requires a 500 liter water tank. We used a 150 liter water tank to test the system and a larger tank will be ordered and purchased before the start of the next semester in June 2009. We purchased an aquarium pump with a filter and an air bubbler to pump the water from the tank into the system. The school has electricity that can be used for the system, so we decided to use a 1.3-meter pump. This pump was the least expensive pump available that would have the adequate amount of power needed for the system's operation. Also, the filter and air bubbler were important aspects because they filtered and aerated the water.

The SIFE team will need to purchase additional materials to grow the plants including seeds, sponges, and liquid fertilizer. Solid fertilizer salts are inexpensive and can be used; however, they are also more complicated to mix. A seedling tray is required to germinate the seedlings. Additionally, pH buffers, a pH meter or pH paper strips (litmus) are necessary to adjust to the correct levels. An electrical conductivity (EC) meter is not required, but is recommended to

test the level of nutrients in the water. Since the plants will not be grown until the start of the semester, a few months after we completed our project, we did not purchase these materials. Therefore, these materials were not factored in the total cost of the system.

An estimate of the total cost of the materials for the construction of the system including the fabrication of the frame is about 9,500 Baht. This was below the initial budget of 15,000 Baht. A list of the materials used for the system is shown in Appendix B. We were not able to include the specific prices of each material because we were unable to obtain the information. Due to time limitations, we were unable to estimate the exact cost of the system with the salvaged materials and the purchased materials for vegetable growth, but by using market prices obtained from the FAO case study and the Mahasarakham local market, we estimated the cost of all materials to be about 12,000 Baht. The estimated prices for the extra materials can be seen in Appendix B.

CONSTRUCTION OF THE HYDROPONIC SYSTEM

The construction of the hydroponic system involved gathering and assembling materials. We purchased all materials locally and constructed the system during our month long stay in Mahasarakham. The steel for the frame of the system was bought at a local supplier and was fabricated on the Mahasarakham University campus. Upon completion of the fabrication of the system, we inspected it at the fabricator's workshop, as seen in Figure 20, and moved it to another location on campus to attach the concrete feet. The frame was then transported to the MSU Demonstration School. There was a designated spot for the system; however, other materials were being stored there and a temporary location for the system was chosen for construction.



Figure 20: Fabrication of the Frame

We purchased materials from several different stores because of the variety of the materials needed. Due to the difficulties of gathering the materials, the amount of time spent gathering materials took longer than expected, which reduced the time allotted for the construction of the hydroponic system to two days. A short period of time for construction was a major limitation because any difficulties encountered while constructing the system had to be solved quickly on site. By the end of our final day, we had finished constructing the frame of the system and the hydroponic bed as seen in Figure 21. The roofing was not attached and the black plastic lining was not completely secured due to a lack of metal clips. Once the SIFE

team received the metal clips, they were able to attach the semi-transparent plastic to the roof and secure the black plastic lining and mosquito netting. The pump and tank assembly were also left for the SIFE students to complete after we left. We explained the assembly to the SIFE team members and they assured us that they understood the steps required to finish the system.



Figure 21: Construction of the System

We also were not able to bore all the holes in the Styrofoam boards. Since the SIFE team members had experience in doing this task for the previous system, we only had to specify the placement of the holes. In order for the DRFT to function efficiently, the holes in the boards need to be aligned with the ridges in the bed shown in Figure 22. In addition, the hydroponic system should be placed on level ground when it is moved to its final location, which will ensure that the water depths are constant throughout the system and the vegetables grow evenly.

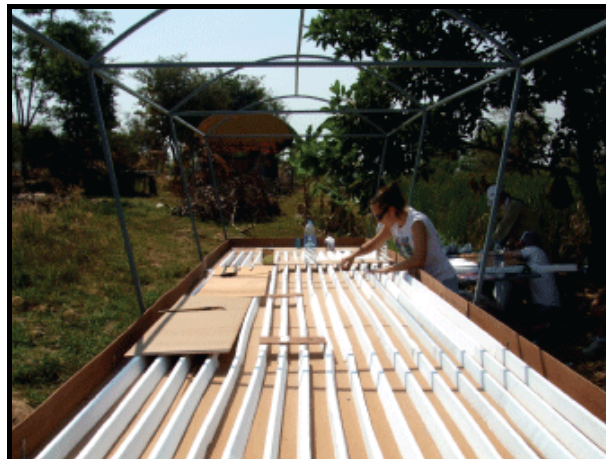

Figure 22: Ridges of DRFT

EDUCATIONAL MATERIALS

We created a teaching manual for the teacher at the MSU Demonstration School, Ajarn Aathit, and business activities for the MSU SIFE team by drawing on the information gathered during our interviews and our research on educational hydroponics. This chapter begins with a summary of information gathered in the interviews with Ajarn Aathit, a description of the content of the teaching manual, and the benefits of and reasoning for each section of the manual. This chapter concludes with an explanation of three business activities produced for the MSU SIFE team and the learning benefits of each.

TEACHING MANUAL

Through conversations with our sponsor, we learned that the SIFE team approached the principal of the MSU Demonstration School about implementing their hydroponic system at the school. Ajarn Aathit, a science and agriculture teacher at the school, decided to help with the implementation after being asked by the principal due to his experience and current use of hydroponics in the classroom. Our group created a teaching manual for Ajarn Aathit in order to help him integrate the hydroponic system into his current curriculum.

To help us define guidelines for the manual, we used the information gathered during our interviews with Ajarn Aathit. These interviews helped us to obtain information about the sizes and education levels of his classes and the amount of time he spends teaching to better our understanding of the structure of his current curriculum. We found that he teaches a total of 230 second-year junior high school students and first-year high school students which are divided into either five or six classes depending on the semester. Each student has approximately 70 minutes of science class per week. We also learned that Ajarn Aathit currently spends about two hours per semester teaching each class about hydroponics, but that he was willing to increase this time to six hours per class per semester to accommodate the hydroponic system and its activities.

In terms of Ajarn Aathit's current curriculum, we found that he teaches three units: agriculture, animal life, and working skills. In the agricultural unit, he mostly focuses on growing and caring for plants, but does not teach much about plant biology, a topic that is often included in curricula involving hydroponics. As mentioned before, we also found that he had used a small hydroponic model in the classroom for demonstration in the past, which showed us that Ajarn Aathit has some knowledge of hydroponics and has experience operating a system. However, he requested that we include information on how to operate the system in the manual.

Our team also discovered that Ajarn Aathit currently uses hands-on farming activities in his curriculum. We found that the younger students grow plants in the soil using traditional farming and the older students cut tree limbs and re-plant them into the soil. However, Ajarn Aathit explained that he finds the students can get bored when they are outside and supported the idea of creating activities or games to increase the involvement of the students. We found

that his main desired learning outcome for the students was for them to be able to have fun while successfully growing plants and learning how to use the hydroponic system.

Through the analysis of the interviews and our research on educational hydroponics, we developed the following guidelines for the teaching manual:

Useful and adaptable- We chose this as a guideline for the teaching manual because we wanted the content of the manual to be useful in that it reflects the specific needs of the teacher, but includes general enough topics so that the manual would be adaptable for other school curricula if SIFE decides to move or replicate the system elsewhere in the future.

Easy to translate- Since the SIFE team has offered to translate the manual into Thai; we used straightforward English to avoid confusion. We also limited the amount of material in the manual to increase the chances of it being translated.

Contains many diagrams and figures- We used supporting figures and diagrams wherever possible to clarify information in the manual to make it easier to understand and to eliminate text to reduce the amount of translation.

Suggests engaging activities that will fit class sizes and times- Since the teacher informed us that the students often get bored when they are outside, we intended to create fun activities for the students to do with the hydroponic system. Each class has about 45 students, which helped us determine if the activities should be done individually or as a group. In addition, we considered that the classes only meet 70 minutes per week and chose activities that could be completed during the class time.

Explains the operation and maintenance of the system- Since the teacher requested more information on the operation and maintenance of the system, we decided that the manual should include detailed descriptions on how the hydroponic system functions.

In order to determine the content and organization of the teaching manual, we drew on relevant case studies, adapting ideas that suited Ajarn Aathit's needs, making sure they were appropriate for the curriculum, the hydroponic system, and for the age of his students. The manual includes the following five sections:

Introduction- This section provides a description of the content and the purpose of the manual. We explained the reasoning behind each section of the manual and emphasized that the teacher has the freedom to modify the manual to better fit his curriculum.

Background knowledge- We considered two relevant case studies and information obtained about Ajarn Aathit's current curriculum and desired learning outcomes when choosing the following three major topics to be discussed in the manual:

Plant biology- This was chosen due to its educational importance in understanding the life cycle, scientific processes, and structure of plants. The Uruguay hydroponics education case study suggested that hydroponics was an effective way of teaching plant structure because all parts of the plant are visible, including the roots. In addition, students can directly observe plant development and understand the various parts and functions of plants (Stajano, 2004). Since most of the students have learned the basics of plant biology, we did not include specific information, but rather a list of general topics that the students should have previously learned.

The science and history of hydroponics- This section is intended to teach the students what hydroponics is and how it works. Other benefits of this section are that the advantages and disadvantages of hydroponics can be presented along with a comparison of hydroponics to traditional farming. This information can be very useful for helping the students understand why the hydroponic system is being implemented at their school as an alternative farming method. We included a small section on the history of hydroponics in the manual to give the teacher the option of incorporating another subject into his teaching. This section is intended to help the students understand how and where hydroponics started.

Maintaining the hydroponic system- This material will be useful to both the teacher and the students because they will need to know how to maintain the system in order to use it for classroom activities. It also involves a hands-on learning approach and allows the students to be active in the operation of the system which is suggested by the Alaskan educational hydroponics case study as an effective way to help students understand the overall process of hydroponic farming (Goff, 2008).

Suggested activities- As suggested by Stajano in the Uruguayan case study, hydroponics provides students, either as individuals or in groups, with the opportunity to directly participate in class activities (Stajano, 2004). This section includes descriptions of activities that correspond with the previously mentioned topics and are intended to be an engaging way to reinforce the lessons learned. We created four interactive activities that will be likely to engage and motivate the students to help with the system, which are listed and described below:

Plant development journal- We intend for the students to complete this activity on an individual basis. The journal would require the students to reflect upon the plant in terms of the size, color, number of leaves, pH levels, or any pests found. The students would also have to include weekly drawings of the plant, which will help them understand the structure and life cycle of the plant and promote creativity. Since the students will be recording the size of the plant in each journal entry, this will allow them to create a growth chart at the end of the semester. In addition, inspecting the plants for pests will not only help their observation skills, but will also allow for the detection and removal of pests from the plant beds which has been suggested as an effective method of pest control (Marulanda and Izquierdo, 1993).

Comparing hydroponic and traditional farming- This is a team activity in which the students will be divided into three groups. The first group will be responsible for monitoring the growth of plants in the soil using traditional farming. The second group will be responsible for growing plants hydroponically. The third group will begin with hydroponic vegetables and then remove the plants just after the seedling stage to replant into the soil. Similar to the Alaskan case study, this activity will allow the students to develop their teamwork skills by working together to grow the plants (Goff, 2004). When the plants are ready to be harvested, the students will compare the final plants on similar criteria to the observation journal. This will allow the students to identify similarities and differences between traditional and hydroponic farming as well as noting the advantages and disadvantages of each.

Cleaning the hydroponic system- As suggested by the FAO, the hydroponic system needs to be thoroughly cleaned after each harvest. Therefore, having the class clean the hydroponic system after its first cultivation would not only satisfy this need, but it would provide the students with educational benefits. Cleaning the system will give the students more hands-on experience working with the system and they will learn this portion of the maintenance if needed in the future. In addition, this activity would help foster teamwork and communication skills among the students.

Making a simple hydroponic system- This activity was modeled from a project done in a middle school in California (National Gardening Association, 2009). This activity includes instructions on how to create a small-scale hydroponic system in order to have the students grow vegetables on their own. The students would use their knowledge of hydroponics to care for the plant and present it to the class at the end of the semester. This activity would be beneficial to the students because they will be applying the knowledge that they gained throughout the semester. It is also promoting the use of hydroponics outside of the classroom which is consistent with SIFE's goals of spreading the idea of hydroponics to other areas.

Expected learning outcomes- The purpose of the learning outcomes portion of the manual is to show Ajarn Aathit the benefits of teaching each topic and activity allowing him to choose the lessons based on what he wants the students to learn and determine if the topics or activities are effective.

Operation manual- An operation manual is included with the teaching manual and will provide the teacher with detailed directions on how to operate and maintain the system in order to keep it functioning properly.

A full version of the Teaching and Operation Manuals can be found in Appendix F.

Although we chose the content of the teaching manual based on the information gathered from Ajarn Aathit, there are still limitations. Due to the language barrier, we may not have

been able to accurately gather information about Ajarn Aathit's needs for the teaching manual. Thus, the manual may be limited because it may not contain all of the information Ajarn Aathit tried to communicate to us. In addition, Ajarn Aathit did not have many ideas or input during the process of creating the manual, which limited our ability to assess and meet his needs.

BUSINESS ACTIVITIES

Our group developed three business activities for the MSU SIFE team that they can use as a model or adapt into their own activity that will better suit their needs. These activities will begin in the second semester of the 2009-2010 academic year and are aimed to be completed outside the classroom as an extracurricular activity. We created the activities based upon the topics the SIFE team wanted to focus on while also considering that the members only have a limited amount of time to devote to the organization and that some of their efforts will be spent preparing for the national SIFE competition. Through our correspondence with the SIFE team, we found that they wanted the students to learn about entrepreneurship, market economics, environmental sustainability, and finance. In addition to learning about these subjects, we also wanted the activities to be engaging, interactive, and easy to implement. These guidelines and the topics were incorporated into three different activities, which were developed by our group. This would provide the SIFE team with different options to choose from and provide them with several ideas that they could use to create their own activity. A complete description of these activities is shown in Appendix F. The activities are:

The Hydroponic Vegetable Business Fair

This activity involves small groups of students creating their own businesses and selling vegetables at a business fair. This fair would be at the school and teachers, parents, and other community members would be invited to attend and buy the hydroponic vegetables. The students would create their own business names and slogans and would have a booth at the fair where they could sell their vegetables. Each team would have to promote their business and the benefits of hydroponics along with determining a price to sell the vegetables. This activity includes a competition during the fair for the students during which the SIFE team would judge the students on various criteria including how well they promoted their particular business and the benefits of hydroponic vegetables, the level of their overall creativity, interaction with the customers, and how much money they made. The top groups in the competition will receive prizes.

This activity would teach the students about entrepreneurship by allowing them to have their own businesses. In addition, the activity would introduce marketing and advertisement techniques since the students are competing against other companies. The students would also learn about finance by pricing their vegetables high enough to make a profit, but low enough to be within the competitors' prices. Lastly, the students would understand the benefits of growing hydroponic vegetables while creating posters and advertisements. This activity, on a larger scale, is beneficial to

the development and promotion of the use of hydroponic vegetables because the fair is open to the teachers, parents, and community members who would learn about these benefits by either seeing the advertisements or attending the fair.

The Hydroponic Vegetable Stock Market

This is an activity that introduces the students to the principles and concepts of the stock market. Each student would be given the same amount of credit, which they could use to buy pretend stocks in the different rows of the hydroponic system. The SIFE students would determine the starting value of each row and adjust them based on the performance of the plants twice a week. For example, all the rows could have the same stock price and then based on how well the vegetables grow the SIFE students would increase or decrease the price. The students would be able to sell or buy stocks with their money twice a week at a specified time. When the vegetables have finished growing, each student would sell their stocks, collect their money, and see how much money they either gained or lost. The students whose strategies yielded the greatest profit would receive prizes. If two or more different vegetables could be grown in the hydroponic system, stocks could be of the different vegetables instead of the different rows.

This activity exposes the students to the stock market, which is an important part of national and international business economics. They would be directly involved in the buying and selling of their stocks and managing their money, teaching them about finance. This hands-on style of learning reinforces the ideas and principles of the stock market.

Owner and Vendor Role Playing

The last activity is a role playing game where half of the students are owners of a hydroponic system and the other half are vendors selling vegetables. Both the owners and vendors are randomly given profiles, which are created by the SIFE team. The profiles would include information such as how much money they have to spend on either producing vegetables or purchasing them to sell. The owners would be told how much money they spent on producing vegetables. They would have to find a vendor who is willing to buy their vegetables and agree upon an amount based on market value. Once everyone has either sold or bought their vegetables, the vendors would then be told how much money their vegetables were sold for. The owners and vendors would then calculate how much money they made and the winners of both categories would be rewarded. This activity would allow the students to have a part in the business of buying and selling goods. They are able to learn how to bargain for prices in order to make a profit which introduces market economics and finance.

Each activity is intended to be fun and engaging in order to spark the interest of the students, causing them to want to participate more. This would teach the students about entrepreneurship and environmental sustainability. Also, these activities could be explained and monitored by the SIFE students. This may require some planning

and coordination for the SIFE team and if the proper amount of effort is not put forth, then the students may not fully achieve the learning outcomes.

SUMMARY, RECOMMENDATIONS, AND REFLECTIONS

This chapter begins with a summary of our project outcomes regarding the hydroponic system and the educational materials. This is followed by our recommendations for the MSU SIFE team for ways to assess the hydroponic system. The chapter concludes with reflections about our project experience including challenges and limitations we faced in the process and the lessons we learned.

SUMMARY OF PROJECT OUTCOMES

Over the course of our project, we were able to produce three main project outcomes which include the hydroponic system, teaching manual, and business activities. The system and educational materials will be presented to the MSU SIFE team, the MSU Demonstration School, and Ajarn Aathit to be used in June 2009. They are designed to enhance the agricultural curriculum at the school and introduce business skills to the students.

HYDROPONIC SYSTEM

We designed a hydroponic system and constructed a majority of the system with the assistance of the MSU SIFE team at the MSU Demonstration School. We chose the deep root floating technique for the hydroponic system. We designed a low cost and economical system constructed of locally available materials which can be seen in Figure 23. The system and frame are modular, allowing it to be disassembled for transport. The system is designed to grow a variety of vegetables and provide approximately 730 plants per harvest. Also, the structure of the system will provide the plants with protection against the natural environment including pests, intense heat, and rain. In addition, this hydroponic system was designed to be easily replicated if successful at the school and implemented elsewhere in Northeast Thailand in other schools or communities.



Figure 23: Hydroponic System

TEACHING MANUAL

The teaching manual was designed to facilitate the integration of the hydroponic system into the existing agricultural curriculum. The manual includes the following five sections:

Introduction- The manual begins with an introduction that provides the teacher with the purpose of each section of the manual.

Background knowledge- We included a list of background topics that Ajarn Aathit can review with the students before moving on to the activities. Based on the information obtained about the teacher's current curriculum, desired learning outcomes, and suggestions from the two case studies, we chose the three main topics: plant biology, the history and science of hydroponics, and maintaining the hydroponic system.

Suggested activities- We included a description of four interactive activities involving the hydroponic system that reinforce the background topics on hydroponics.

Expected learning outcomes- We included learning outcomes for each topic and activity to allow Ajarn Aathit to choose which topics to teach based on what he wants his students to learn.

Operation manual- The final section of the teaching manual is an operation manual for the system, which includes instructions for the maintenance of the system.

In the creation of the teaching manual, we worked closely with the teacher, Ajarn Aathit, in order to increase the likelihood of the system and manual being accepted into the curriculum. The manual will not be useful until it is translated from English to Thai by the MSU SIFE team.

BUSINESS ACTIVITIES

Our group developed three business activities for the MSU SIFE team which include:

- The hydroponic vegetable business fair
- The hydroponic vegetable stock market
- Owner and vendor role playing

The SIFE team can use these activities as a model to develop their own activity that will better suit their needs. These business activities are intended to help the SIFE team accomplish their mission statement of promoting businesses practices, entrepreneurship, free enterprise, and environmental sustainability while being fun and engaging.

RECOMMENDATIONS FOR FUTURE WORK

Since we were only able to help in the construction of the hydroponic system during our stay in Mahasarakham and unable to assess its operation or integration into the curriculum, we developed recommendations to assess the system. We created two categories of assessments, one to monitor the performance of the system and the other to assess the educational uses of the system. These recommendations were designed for the benefit of the SIFE team and future researchers.

MONITORING THE HYDROPONIC SYSTEM

We recommend that the SIFE team monitor the operation of the hydroponic system. In order for the MSU SIFE team to be able to meet their goals by using the hydroponic system as a platform of business education, the system must be performing adequately. The aspects of operation that can be monitored are:

How well is the system operating?

The SIFE team can determine if the system is currently in operation by speaking with Ajarn Aathit. If the system is currently being used, then the SIFE students can gather Ajarn Aathit's opinions on its operation. If the system is not in use, then the SIFE team can determine the reasons why. Finding this information would be helpful to the SIFE team because they can investigate possible ways to re-implement or relocate the system to another school if they feel it is the best option.

How well is the system being maintained?

In order to determine if the system is being properly maintained, the SIFE team can speak with Ajarn Aathit about any problems that he has had with the maintenance of the system and also observe the class during activities that involve the operation of the system. The SIFE team can assess the maintenance of the system and determine if they need to reinstruct the teacher and students in accordance with the operation manual. This assessment is valuable to the SIFE team because the results will allow them to see if the operation manual provides enough information on the maintenance of the system and if not, they can make adjustments to fit their needs.

How efficiently has the system been growing vegetables?

The SIFE team can monitor the efficiency of the system in growing healthy vegetables by keeping a record of observations of the plant growth in the hydroponic system. Similar to the observation journal activity in the teaching manual, the SIFE team can record information such as the number and sizes of plants, how healthy they appear to be, and if there have been any pests or diseases detected. This assessment can be beneficial to SIFE because they can determine important information about the efficiency and productivity of the system which can be helpful in the future if they chose to use it to make a profit.

How does the actual yield of the system compare with the expected yield?

From the information gathered from the previous assessment, SIFE can also compare the actual yield of the system with the expected yield by counting the number of plants successfully harvested. This number can be compared to the maximum yield of approximately 730 plants per harvest. As with the previous assessment, SIFE can use this assessment to determine how productive and efficient the system has been to see if they should investigate the possibility of replicating the system to grow plants for a profit.

EVALUATING THE EDUCATIONAL USES OF THE SYSTEM

We recommend that the SIFE team assess the success of the hydroponic system in the classroom and for SIFE's own use. This will help the SIFE team assess the effectiveness of the system in the curriculum and to help them determine what they can do in the future. The system can be assessed by the following evaluations:

Is the system being used by the teacher in the classroom?

The SIFE team can determine if the system is being used in the classroom by talking with the teacher and students about how they have used the hydroponic system. If the teacher is using the system in his curriculum, then the SIFE team could explore exactly how it is being used. However, if the system is not being used then the SIFE team should identify why. Also, it would be beneficial to know what has worked well with the system and what has not, so the SIFE team can make changes or adjustments for future projects.

Are the teaching materials being used by teacher in the classroom?

It is also important for the SIFE team to determine if Ajarn Aathit is using the teaching materials in the classroom by speaking with him about what specific information or activities he used. Again, similar to the hydroponic system, it would be beneficial to learn what material he found useful and what was not.

Are there students interested in the hydroponic system outside of the classroom?

By identifying if the students have expressed interest in the system outside the classroom, the SIFE team can assess how engaging and interesting the students found the curriculum, activities, and the hydroponic system. The SIFE team can speak with the teacher to see if any students have expressed outside interest or they can speak with the students directly themselves. If the students are interested, the SIFE team can look into the possible options of replicating the system at other schools or creating more extracurricular activities for the students.

Has SIFE been able to use the system to achieve their goals?

The SIFE team can evaluate how well the system has helped them achieve their goals. They can assess whether or not the students learned about business and entrepreneurial skills and the environmental impacts and benefits of hydroponics. The SIFE team can speak with the teacher and the students to see if these learning outcomes were achieved.

REFLECTIONS

Over the course of our project, our team has gained some valuable knowledge about Thai culture, teamwork, and living in a new environment. Although the hydroponic system and educational materials are now out of our hands, it can be helpful to discuss the challenges and limitations we faced during our project work and to reflect upon the key lessons we learned from our project experience.

We tried to include aspects throughout our project that would increase the likelihood of the hydroponic system being used. However, we realize that we will not be there for the actual implementation of the hydroponic system and that there will be some key factors which will affect the likelihood of its implementation. The fact that the teacher, Ajarn Aathit, has past experience with hydroponics may increase the chances that he will know how to operate and be excited to use the new system in his curriculum. Another factor that may help its integration into the school's curriculum is the SIFE team's involvement with the system. Since we tried to include them as much as possible in the design and construction of the system, we hope that they will be excited and have a feeling of ownership for the system. We also hope that they will be motivated by the possibility of doing well in their national SIFE competition by including the hydroponic system in their project.

Alternatively, we realize that there is a chance that the SIFE team may not be able to dedicate the time necessary either to ensure that the system is implemented properly or to translate the teaching manual. In addition, we recognize that the teacher did not seek this project for his classroom, but rather he was sought by the principal to be involved with the project due to his prior knowledge of hydroponics. This may affect his ability to dedicate time to the maintenance of the system or to integrating the teaching manual into his curriculum.

Although we were able to construct a hydroponic system and produce educational materials, we encountered some challenges and limitations. As outsiders in Thailand, and more specifically in Mahasarakham, our lack of Thai language skills and cultural knowledge limited our ability to accomplish tasks related to our project and to our everyday lives. This affected our ability in tasks such as speaking with the science teacher for our interviews, finding local transportation to search for materials for our project, or just traveling around town. Our team had to adjust to these limitations which required us to depend on other people more than we were accustomed to.

We worked on this project with the MSU SIFE team; however, this organization is an extra-curricular activity and the students were often busy and involved in their schoolwork. The SIFE team's availability was particularly limited due to the fact that our stay in Mahasarakham was between their mid-term and final exams. This posed a challenge for us in finding time for discussion, which limited their involvement in the development of the hydroponic system. Also, SIFE is a new organization at MSU and has not had enough time to fully develop. During our stay in Mahasarakham, the SIFE team was restructuring their

organization after attending a national SIFE conference in Bangkok. Since they were still developing as an organization, it was hard for us to get them involved in the project.

Through this experience, we have learned a number of lessons that will help us in the future. We realized early on that difficulties may arise because of cultural barriers. We found that Thai beliefs about time and commitment are generally different from ours. In Thai culture, it is not uncommon for people to be late or reschedule plans, even in a professional setting. This taught us to be patient, flexible, and prepared for unexpected changes. We also learned that we had to emphasize the importance of meetings and deadlines related to our project to our sponsor and the SIFE team.

We also realized that it is helpful and beneficial to build relationships and trust early when working on a project, especially in collaboration with people from another culture. We felt that once we became close with the SIFE team, our project work and stay in Mahasarakham was more efficient and enjoyable. Unfortunately, by the time we were able to develop this relationship, it was near the end of our visit. We feel that it would have been beneficial for us and our project work to foster these relationships sooner, allowing us to collaborate more closely with the SIFE team during the project or in a social setting.

We learned some valuable lessons about teamwork during our stay in Mahasarakham. We quickly realized that it was important to delegate tasks to use our time effectively. This usually meant that some group members would stay in the office while others were performing project-related tasks with either our sponsor or a Thai student. As a result, keeping open communication between the team was crucial because we had to ensure that we were all updated with the current status of our project. We also learned that although team members may be drawn to the project-related tasks that interest them the most, it is beneficial to experience all aspects of the project and step outside of our “comfort zones” once in a while. Thus, we alternated the combinations of team members who would perform certain tasks.

Overall, this project was a positive learning experience for our entire group. We were able to gain valuable knowledge about Thai culture, teamwork, and ourselves. We hope that the hydroponic system and educational materials produced over the course of this project will be helpful to the SIFE team and the MSU Demonstration School and perhaps others in the future. If the system proves to be effective as an educational tool, we hope that it could be readily replicated elsewhere in Northeast Thailand and have a positive impact on other educational programs and communities.

REFERENCES

- Assawin, W. (2007). Dr. Sumet Tantivejkul: The philosophy of sufficiency economy for the world. *Thailand Illustrated*, 24(1)
- Bradley, P., & Marulanda, C. (2000a). Building by design: Hydroponics in developing countries, part 1. *The Growing Edge*, 11
- Bradley, P., & Marulanda, C. (2000b). Building by design: Hydroponics in developing countries, part 2. *The Growing Edge*, 11
- Bradley, P., & Marulanda, C. (2000c). Building by design: Hydroponics in developing countries, part 3. *The Growing Edge*, 12
- Court, D (1997). *Types of Hydroponic Systems*. Retrieved November 18, 2008, from Dave's hydroponic experiments from http://www.dbcourt.co.uk/hydroponics/System%20_types.html
- Doyle, J. K. (2008). Handbook for IQP Advisors and Students. *Worcester Polytechnic Institute, IGSD*.
- Dym, C, & Little, P (2004). *Engineering design: A project-based introduction*. John Wiley & Sons, INC
- Food and Agricultural Organization of the United Nations. (1993). *Technical manual: Popular hydroponic gardens*. Santiago, Chile:
- Gypmantasiri, P., Sriboonchitta, S., & Wiboonpongse, A. (2001). *Policies for agricultural sustainability in northern thailand* New York: International Institute for Environment & Development.
- International Fund for Agricultural Development. (2001). *Rural poverty report 2001: The challenge of ending rural poverty*. New York.
- Jirapaet, K. (2007). *The tenth national and social development economic plan*. Retrieved November 17, 2008, from <http://www.itd.or.th/en/node/256>
- Jones, J (1997). *Practical Guide for the Soilless Grower*. Boca Raton, FL: St. Lucie Press.
- Kao, T (1991).The Dynamic Root Floating Hydroponic Technique. Retrieved December 2, 2008, from <http://www.agnet.org/library/eb/330/>
- Kid-Arn, Sirinapa. "Joint Project Between Mahasarakham University SIFE Team and Worcester Polytechnic Institute SIFE Team in Mahasarakham, Thailand." E-mail to the author. 30 Nov. 2008.

- Klausner, William J. (n.d.) *Reflections on Thai Culture*. Bangkok, Thailand: The Siam Society Under Royal Patronage, 1993: 335.
- Marulanda, C., & Izquierdo, J. (1993). *Technical manual: Popular hydroponic gardens : Audiovisual course*. Santiago: FAO Regional Office for Latin America and the Caribbean.
- Molle, F., & Floch, P. (2008). Megaprojects and social and environmental changes: The case of the thai “Water grid”. *AMBIO: A Journal of the Human Environment*, 37(3), 199-204.
- National Economic and Social Development Board, & World Bank. (2005). *Thailand Northeast Economic Development Report*. from http://siteresources.worldbank.org/INTTHAILAND/Resources/333200-1097667766090/need_report-2005-eng.pdf
- National Gardening Association. (2009). *Floating Gardens in Soda Bottles*. from <http://www.kidsgardening.com/hydroponicsguide/hydro7-3.asp>
- Parnwell, M., & Bryant, R. L. (1996). *Environmental change in south-east asia: People, politics and sustainable development* Routledge.
- Resh, H (1997). *Hydroponic Food Production*. Santa Barbara, California: Woodbridge Press Publishing Company.
- Rigg, J. (1985). The role of the environment in limited in the adoption of new rice technology in Northeastern thailand. *Transactions of the Institute of British Geographers*, 10, 483. Retrieved from <http://www.jstor.org/stable/621893>
- Rigg, J. (1987). Forces and influences behind the development of upland cash cropping in north-east thailand. *The Geographical Journal*, 153(3), 370-382. Retrieved from <http://www.jstor.org/stable/633674>
- Students in Free Enterprise (2008) *SIFE Thailand*. Retrieved November, 2008, from <http://www.sifethailand.org>
- Stajano, M. C. (2004, Jan/Feb). Simplified Hydroponics for Kindergartners. *Practical Hydroponics & Greenhouses* (74), pp. 49-57.
- Turner, B. (2008). *How Hydroponics Work*. Retrieved November 18, 2008, from <http://home.howstuffworks.com/hydroponics.htm>
- United Nations Thailand. (2008). *Thailand Population*. Retrieved November, 2008, from <http://www.un.or.th/thailand/index.htm>

Voland, G. (2004). *Engineering by Design*. (2nd ed.). Upper Saddle River, NJ: Pearson Educations, Inc.

Wildlife Fund Thailand under the Royal Patronage of HM the Queen and Food and Agricultural Organization Regional Office for Asia and the Pacific. (2006). *Emergency Assistance to the Affected Farmers to Restart Agricultural Production in Southern Thailand*. Food and Agriculture Organization.

APPENDIX A: INTERVIEW GUIDES AND SUMMARIES

Contents:

- Email Questions: MSU SIFE Team
- Email Summary: MSU SIFE Team
- Interview Guide: MSU SIFE Team Advisor
- Interview Summary: MSU SIFE Team Advisor
- Interview Guide: FAO in Bangkok
- Interview Summary FAO in Bangkok
- Interview Guide: MSU Demonstration Teacher
- Interview Summary: MSU Demonstration School Teacher

EMAIL QUESTIONS: MSU SIFE TEAM

- Details about the storm that destroyed the previous hydroponic system and how did it destroy the system? Did the storm blow the system over, or was the system flooded?
- How much did it cost to build and maintain the hydroponic system?
- What was the market price of the vegetables?
- What materials were used to construct the hydroponic system?
- What type of hydroponic system was used? If you have any design plans please include them.
- What vegetables were grown in the past?
- How much food does the school need?
- Is there a specific budget for the future hydroponic system?

EMAIL SUMMARY: MSU SIFE TEAM

Date: November 29, 2008

Time: 5:00 pm

Note: These are answers taken directly from the SIFE student's reply to our email. All of our questions were not answered, but there was some additional information included which is given at the end of this summary.

- Details about the storm that destroyed the previous hydroponic system and how did it destroy the system? Did the storm blow the system over, or was the system flooded?
 - The roof that we previously used had the problem when it rained water could not drain out so it gathered in the space between the roof. The plastic that we used to cover it could not support the heavy load of rainwater so the plastic gave way and the rainwater destroyed the vegetables.
- How much did it cost to build and maintain the hydroponic system?
 - The actual cost use for an industry standard hydroponics tank is 50,000 Baht (1,418.84 USD*) but we decreased the cost from 50,000 Baht (1,418.84 USD*) to 5,000 Baht (141.88 USD*)
- What was the market price of the vegetables?
 - The price of vegetables in the market they sell 50-80 Baht per kilogram depending on the kind of vegetable, if we sell Chinese Kale the price for this is 50 Baht/kilo, for Chinese mustard it 80 Baht/kilo.
- What materials were used to construct the hydroponic system?
 - Materials that we used are:
 - mosquito wire screen,
 - black plastic,
 - blue screen,
 - clear plastics to be a roof,
 - wood to support the building,
 - plywood,
 - sheet foam to make gully,
 - rubber tube,
 - nails,
 - glue,
 - sponge (used for growing plants)
- What type of hydroponic system was used? If you have any design plans please include them.
 - We used DRFT hydroponic system.
- Additional Information
 - From the beginning we instructed the school students in Ban Ma Kok School how to build and take care of the hydroponics platform. We built it by ourselves with the help of an expert from local government in the process to

make hydroponics vegetable. The first stage was building the frame using eucalyptus wood to make pillars, structure, and support building. We then used plywood for the floor, and black plastic sheeting to create the hydroponic water tank. Green plastic mesh sheeting and clear plastic waterproof sheeting was used for the roof and blue plastic mesh as an insect screen around the sides of the tank and polystyrene sheets were used to provide the growth cycle support for the plants.

- Another problem is the temperature in N.E. Thailand has increased more than previous years, so the temperature in the hydroponics platform increased and make vegetable wilt and die. We tried to solve the problem by covering the roof with Temperature reducing material (villagers use it to make roof like a cottage) because we thought the heat problem was from the plastic sheeting that we were used. However, this blocked out the light reducing the growth of the plants. This resulted in any profit that we had growing vegetables in hydroponics did not increase and we had to shelve the project until a viable solution could be found.
- With WPI offering technical expertise, we decided to move this project to be our next project in 2008/9. The main problem is that N.E. Thailand has unstable temperatures, for instance we mean 3 days very hot, after three days very heavy rain and after that it become hot again, so it make vegetables that we grow cannot adjust itself within the low cost structure we can build which does not control the temperature.

INTERVIEW GUIDE: MSU SIFE TEAM ADVISOR

Past Hydroponic System Construction

- 1) Was a pump used in the previous system?
- 2) How did you determine the size of the system and structure?

Past Hydroponic System Operation and Maintenance

- 1) How much did it cost maintain the hydroponic system (per day, month, etc)?
- 2) What vegetables were grown in the past system and how did you choose them? Were there any vegetables that failed to grow or any that grew particularly well?

Information for Future Hydroponic System

- 1) Do you have any specific suggestions or improvements for the system we will be building?
- 2) Is there a specific budget for the future hydroponic system?

Information on Educational Program

- 1) Why do you want to create a hydroponic system in the demonstration school?

INTERVIEW SUMMARY: MSU SIFE TEAM ADVISOR

Date: January 19, 2009

Location: Maharakham University

Past Hydroponic System Construction

- 1) A pump was used in the previous system.
- 2) The size of the system and structure was based on the size of the materials available.

Past Hydroponic System Operation and Maintenance

- 1) Information was unknown on the cost to maintain the system
- 2) Chinese Kale was grown in the previous system and there was no specific information on what kinds of vegetables failed to grow or grew well

Information for Future Hydroponic System

- 1) The SIFE team wanted the system to be modular, robust enough to with stand the weather conditions, and easy and accessible for school children to operator
- 2) The SIFE team had about 15,000 Baht in their budget

Information on Educational Program

- 1) The hydroponic system at the school would serve as a pilot program for the SIFE team so they could see that a hydroponic system could be successful and they could use this system as a model to integrate in other schools and villages.

This was the project summary we sent to the FAO prior to our interview:

The goal of our project is to design and implement a low-cost, low-maintenance, robust hydroponic system in the rural village of Ban Ma Kok, Thailand that can be easily replicated to provide nutrition and income in other rural areas. A previous system was constructed last year by the Mahasarakham University SIFE team. The system was built to provide vegetables for lunch at the local school and to sell the surplus in local markets. This system was destroyed when a storm produced large amounts of rain that was unable to drain off the roof and the plastic ripped open and flooded the system. Other problems that were encountered were the intense heat of the region and the low profitability of the system. The system was a dynamic root floating technique, where the plants float on top of nutrient-rich water. We are being asked to re-design or modify the previous design in order to solve these problems. We have about 80 square meters to build the system in and we have a limited budget. The previous system was built using eucalyptus wood for the pillars and support structure. Plywood was used to make the channels which were then covered with polyethylene plastic. The roof was covered with transparent plastic sheathing and the sides were covered with mosquito nets.

These were our interview questions:

- Do you think it is becoming more popular? Why or why not?
- Is hydroponics used frequently in Thailand? If so where?
- What kinds of vegetables are being grown in the systems?
- What type of system is used?
- Do you have any information on case studies in Thailand that involve the use of hydroponics?
- Do you have any information on any incentive programs, policies, low interest loans, or grants for hydroponic systems?
- Do you have information on the vegetables consumed in the region?
- Do you have any other useful information that could help us?
- Do you know anyone else we could talk to about this?

INTERVIEW SUMMARY: FAO IN BANGKOK

Date: January 14, 2009

Time: 10:00am

Location: FAO Headquarters, Bangkok, Thailand

The interview was done in an informal manner with some questions as well as open discussion between two hydroponic experts from the FAO and our project group. The topics were based upon the FAO Interview Guide on the previous page.

When asked about the use of hydroponics in Thailand, the representatives explained that they had funded over eighty hydroponic units in southern Thailand to help farmers after the tsunami. They noted that commercial hydroponics is popular in Bangkok and smaller farms can be found in southern tourist areas where they use or sell the vegetables at resorts and restaurants. When asked how the farmers sold their vegetables, the representatives explained that the farmers would transport their own goods to the market if they had transportation otherwise they would sell them to a “middleman” who would pay them for the goods.

The representatives said that they did not currently have any hydroponics projects in northern Thailand because the main consumers are the local people and there is not much opportunity to grow and sell vegetables for a profit. Some challenges they mentioned related to hydroponics in the Northeast were the environmental conditions such as intense heat and erratic rainfall during the rainy season. The rainfall can damage the system’s roof or enter through the sides of the structure if it is windy. They also said that since the water is highly saline, the water used for the system may need to be treated beforehand, increasing costs and labor. During the dry season, there needs to be a source of water for the system such as stored rainwater from the rainy season.

The representatives told us some of the vegetables that they have successfully grown using hydroponics including cabbage, morning glory, kale, and a variety of Thai vegetables. They noted that tomatoes and eggplants have a good market value, but are significantly harder to grow.

Regarding the type of system to use, they said that the Nutrient Film Technique (NFT) would be the best, but maintenance is difficult and the plants would die quickly if the flow was not continuous. The FAO hydroponic systems that they implemented in the south used the Dynamic Root Floating Technique (DRFT) system which they explained was easy to maintain and had the best value.

In terms of the overall maintenance of the system, the representatives suggested that the entire system be cleaned after each cultivation. They noted that liquid fertilizer requires less maintenance, but buying the nutrients separately and then mixing them ourselves would be much more cost effective. They also advised against growing several different plants

simultaneously in the same system because that would increase the chances for disease in the plants.

The representatives provided us with the name and address of a nearby hydroponic farm as well as the name of its supplier for the frame and equipment of their hydroponic systems.

INTERVIEW GUIDE: MSU DEMONSTRATION SCHOOL TEACHER

Interview 1:

- 1) What grades do you teach?
- 2) Do you teach one subject or do you teach a few different ones? (Depending on answer ask about classes)
- 3) What is the teacher's schedule?
- 4) What curriculum do you have on plant growth, etc. do you have?
- 5) Where does our project fit into the current curriculum?
- 6) Are there other agricultural programs being used now? If so how are the programs run? How are the students involved, etc?
- 7) Are there any current incentive/motivation/reward system used in the classroom?
- 8) What would you like the students to learn from using the hydroponic system?
- 9) How many children will be working with the system?
- 10) How long will the "unit" on the hydroponic system last?
- 11) How much time will the students have to work on the project? Will time be given to the students during the school day to work on the project?
- 12) What do you want to do with the vegetables once they are grown? What has been done?

Interview 2:

- 1) What does the National Curriculum suggest that the second year junior high students should learn about agriculture? What agricultural topics do you teach these students?
- 2) What does the National Curriculum suggest that the first year high school students should learn about agriculture? What agricultural topics do you teach these students?
- 3) We would like to create a manual to help you work the system into your current teaching as easily as possible. Do you have any lesson plans for your agriculture classes that we could have to help us do this?
- 4) What school activities do you find the children enjoy doing the most? Do you have any suggestions for types of activities for us to create such as games, competitions, or projects?
- 5) Is there any information or resources that we can give you that would make it easier to include the hydroponic system in your lessons?
- 6) We have made an outline of the topics that we can include in the manual. Could you please rank the topics in order of importance? Is there anything that you would like to add to the outline?
- 7) Along with the MSU SIFE Team, we would like to create an activity with the hydroponic system that introduces the students to business skills. Do you have any ideas of where this could fit into your curriculum?
- 8) Do you know of any after-school programs or clubs at the school that may be interested in working with the SIFE team and the hydroponic system on business activities?
- 9) Would you like your students to be involved in the construction of the system?

INTERVIEW SUMMARY: MSU DEMONSTRATION SCHOOL TEACHER

Interview 1:

Date: January 26, 2009

Time: 10:00 am

Location: Maharakham University Demonstration School

For this interview one of the Professors translated our questions into Thai and asked the teacher for his answers. The Professor recorded the responses in Thai and after the interview the Professor translated the responses to the questions into English for us to record.

- 1) What grades do you teach?
 - The teacher teaches 2nd year junior high students, classes 2-1 to 2-5 for the first semester. In the second semester he teaches 1st year high school students, classes 4-1 to 4-5 and 4-7. All classes have about 45 students.
- 2) Do you teach one subject or do you teach a few different ones? (Depending on answer ask about classes)
 - The teacher teaches three subjects in one semester: agriculture, animal and working skills.
- 3) What is the teacher's schedule?
 - Monday 2pm-4pm
 - Tuesday is free
 - Wednesday 1pm-4:20pm
 - Thursday 10am-12am
 - Friday 8:30am-10am
- 4) What curriculum do you have on plant growth, etc. do you have?
 - The 2nd year junior high students grow plants in the soil. The 1st year high school students re-root trees.
- 5) Where does our project fit into the current curriculum?
 - The teacher teaches hydroponics to both classes for 2 hours, but with new system will now expand it to 6 hours.
- 6) Are there other agricultural programs being used now? If so how are the programs run? How are the students involved, etc?
 - The students have to grow their own plants for 2 months and can either take it home or re-plant it on campus afterwards.
- 7) Are there any current incentive/motivation/reward system used in the classroom?
 - The students receive a good grade if their plants successfully grow.
- 8) What would you like the students to learn from using the hydroponic system?
 - That the students will be able to grow plants. (Note: Unsure of this answer)
- 9) How many children will be working with the system?
 - About 230 per semester.
- 10) How long will the "unit" on the hydroponic system last?
 - About 6 hours (Note: Unsure about this answer)

- 11) How much time will the students have to work on the project? Will time be given to the students during the school day to work on the project?
 - In school day they have about 70 minutes a week.
- 12) What do you want to do with the vegetables once they are grown? What has been done?
 - The plants are usually taken home to be eaten or sold to the teachers at the school
 - Currently the teacher only teaches the “growing up” of the plant
 - During the break between semesters there is a gardener who can look after the plants/system

Interview 2:

Date: February 5, 2009

Time: 10:00 am

Location: Maharakham University Demonstration School

For this interview one of the Professors and one of the SIFE students translated our questions into Thai and asked the teacher for his answers. They then translated the responses into English for us to record.

1. What does the National Curriculum suggest that the second year junior high students should learn about agriculture? What agricultural topics do you teach these students?
 - Regarding agricultural topics, the teacher only teaches how to plant vegetables using soil. He does not teach much plant biology– only how to take care of the plant (watering, growing). The teacher mentioned he doesn’t like to use chemical fertilizers
2. What does the National Curriculum suggest that the first year high school students should learn about agriculture? What agricultural topics do you teach these students?
 - For the 10th grade. The teacher teaches how to propagate branches using grafting and how to raise animals. These topics are under the national curriculum.
3. We would like to create a manual to help you work the system into your current teaching as easily as possible. Do you have any lesson plans for your agriculture classes that we could have to help us do this?
 - The teacher agreed that a manual to help integrate the system into his lesson plans would be helpful. He would like to know the amounts of nutrients each vegetable requires. He mentioned two vegetables they grow: “kanon” and Chinese leaf and would like more information on their nutrient needs.
4. What school activities do you find the children enjoy doing the most? Do you have any suggestions for types of activities for us to create such as games, competitions, or projects?
 - Normally, when the teacher takes students outside they become very bored. The teacher wants us to create activities or games to make children more involved and have fun as well.
5. Is there any information or resources that we can give you that would make it easier to include the hydroponic system in your lessons?







- The teacher would like us to include information on how to use the hydroponic system.
- 6. We have made an outline of the topics that we can include in the manual. Could you please rank the topics in order of importance? Is there anything that you would like to add to the outline?
 - The teacher likes the outline. When asked if he would like anything added or removed, he said no.
- 7. Along with the MSU SIFE Team, we would like to create an activity with the hydroponic system that introduces the students to business skills. Do you have any ideas of where this could fit into your curriculum?
 - Any activities we create can be implemented during the next semester which is in the middle of May/June.
- 8. Do you know of any after-school programs or clubs at the school that may be interested in working with the SIFE team and the hydroponic system on business activities?
 - The teacher mentioned that he was unsure if the environmental club was still active and that he is in charge of the fishing club.
- 9. Would you like your students to be involved in the construction of the system?
 - The teacher would like his students to work with us during construction. He gave us a schedule with times of the classes he teaches.

APPENDIX B: INFORMATION ON CONSTRUCTING A HYDROPONIC SYSTEM

FRAME FABRICATION MANUAL

Directions for Fabrication

Materials

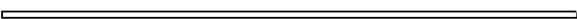
	<i>3/4" (1.905 cm)</i>
13 cm (42 bars)	
32 cm (8 bars)	
	<i>1" (2.54 cm)</i>
25 cm (8 bars)	
105 cm (8 bars)	
120 cm (8 bars)	
150 cm (17 bars)	
200 cm (25 bars)	
220 cm (4 bars)	

Drilling

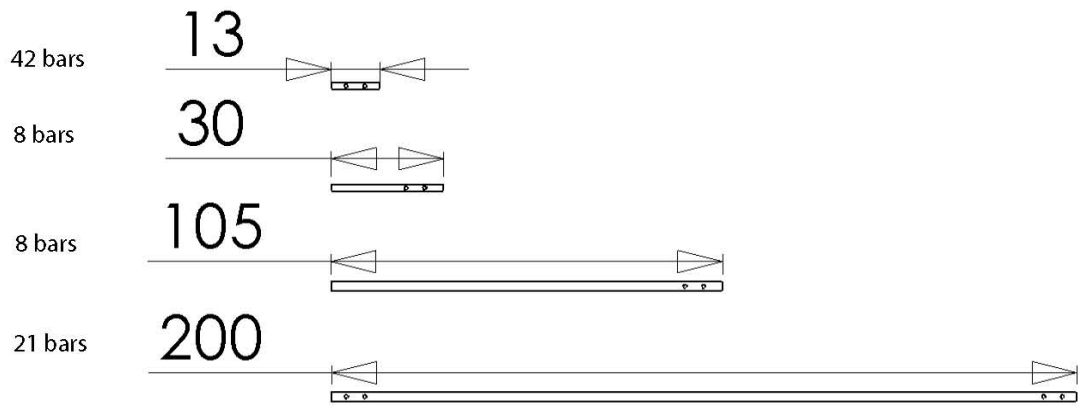

13 cm bar

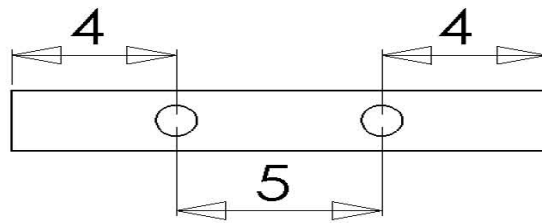

30 cm bar

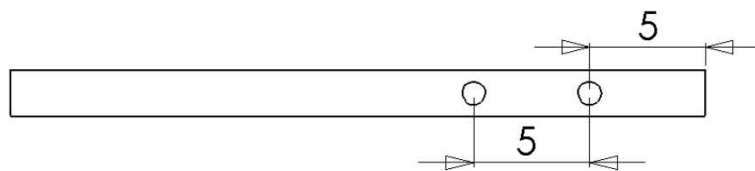

Drilling

105 cm bar

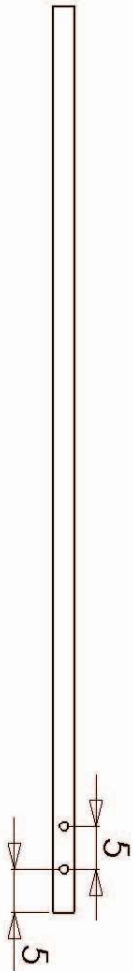

200 cm bar

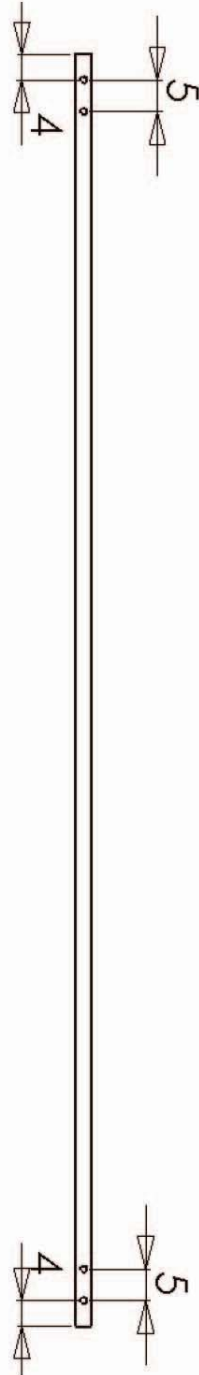

Bending 220 cm (4 bars)

Arc radius 150 cm
End to End 200 cm

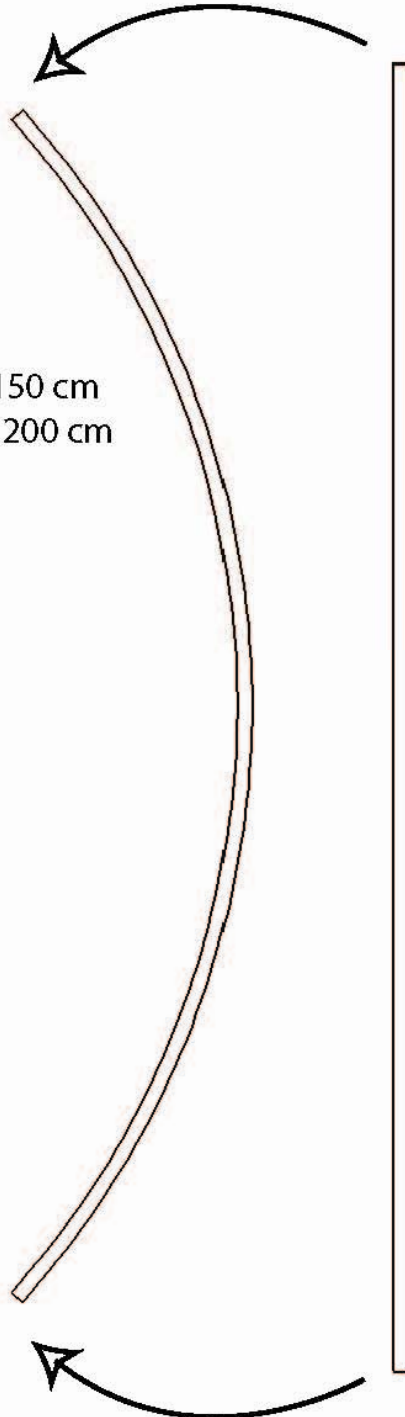

Middle X 2

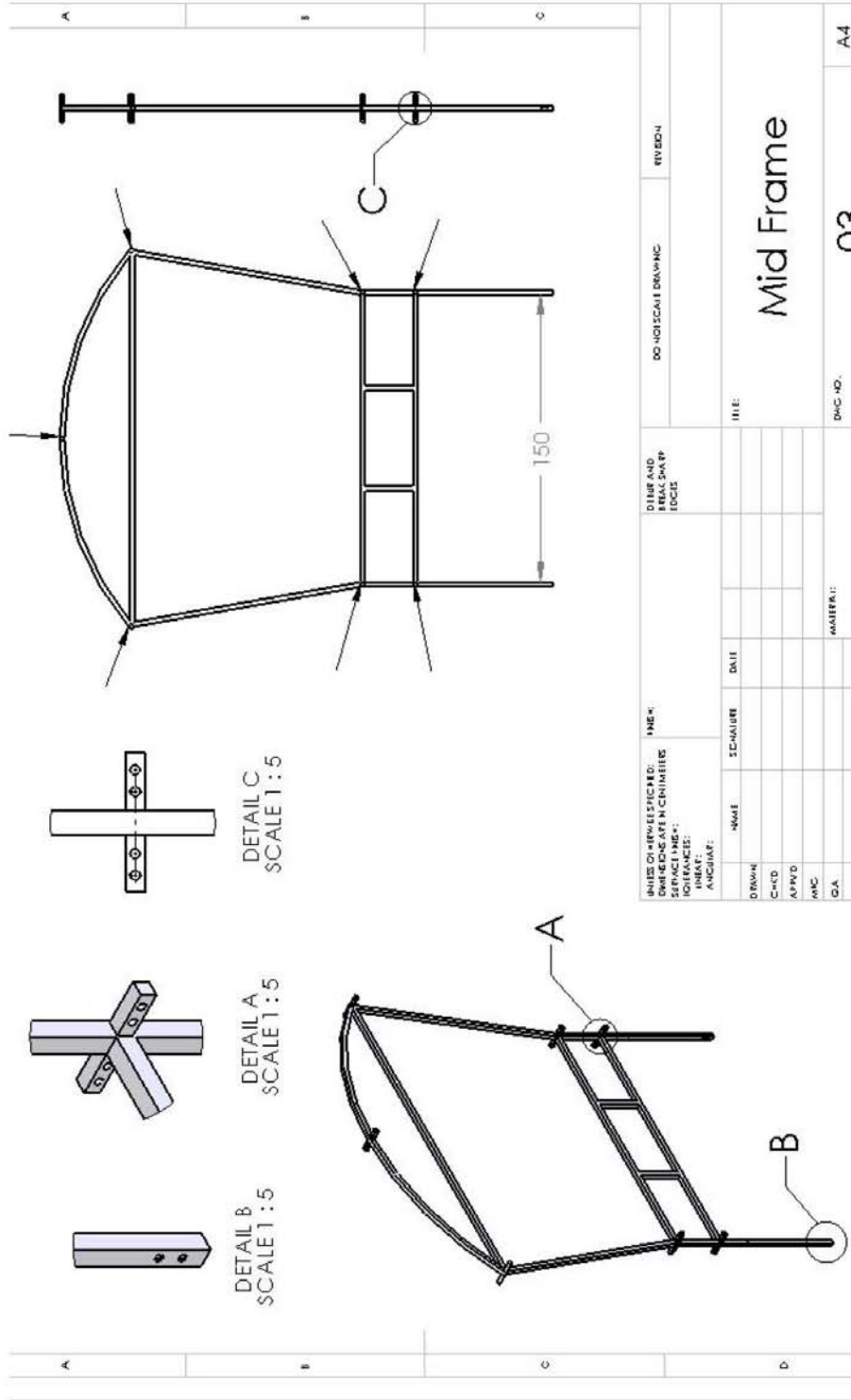

Support Assembly X 3

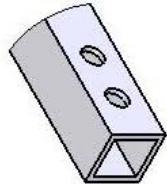
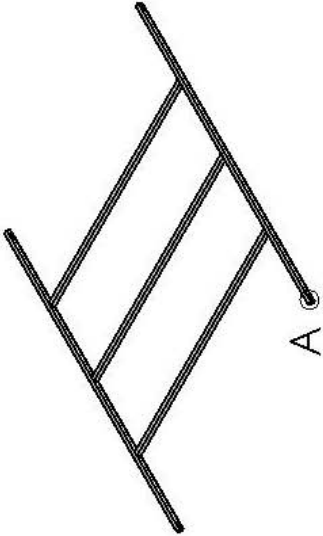
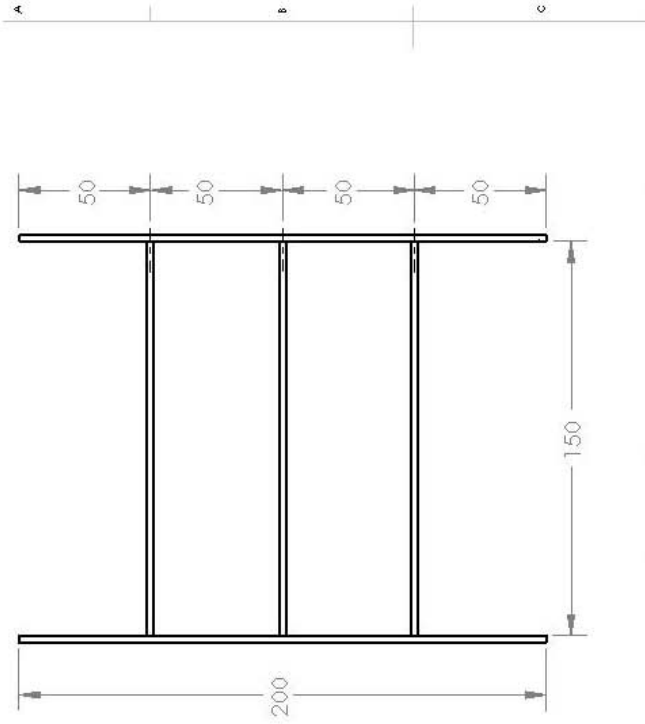

DETAIL A
SCALE 1 : 2

UNLESS OTHERWISE SPECIFIED: DIMENSIONS ARE IN CM		INCHES:		REVISION	
SURFACE FINISH:		TOLERANCES:		DO NOT SCALE DRAWING	
FINISH:		ANGLE:		REVISION	
NAME	SCHEMATIC	DATE	TITLE:		
DESIGN			Support		
CHECK					
APPROVED					
MFC					
D.A.					
MATERIAL:			DWG. NO. 07		
			A4		

Joint Assembly

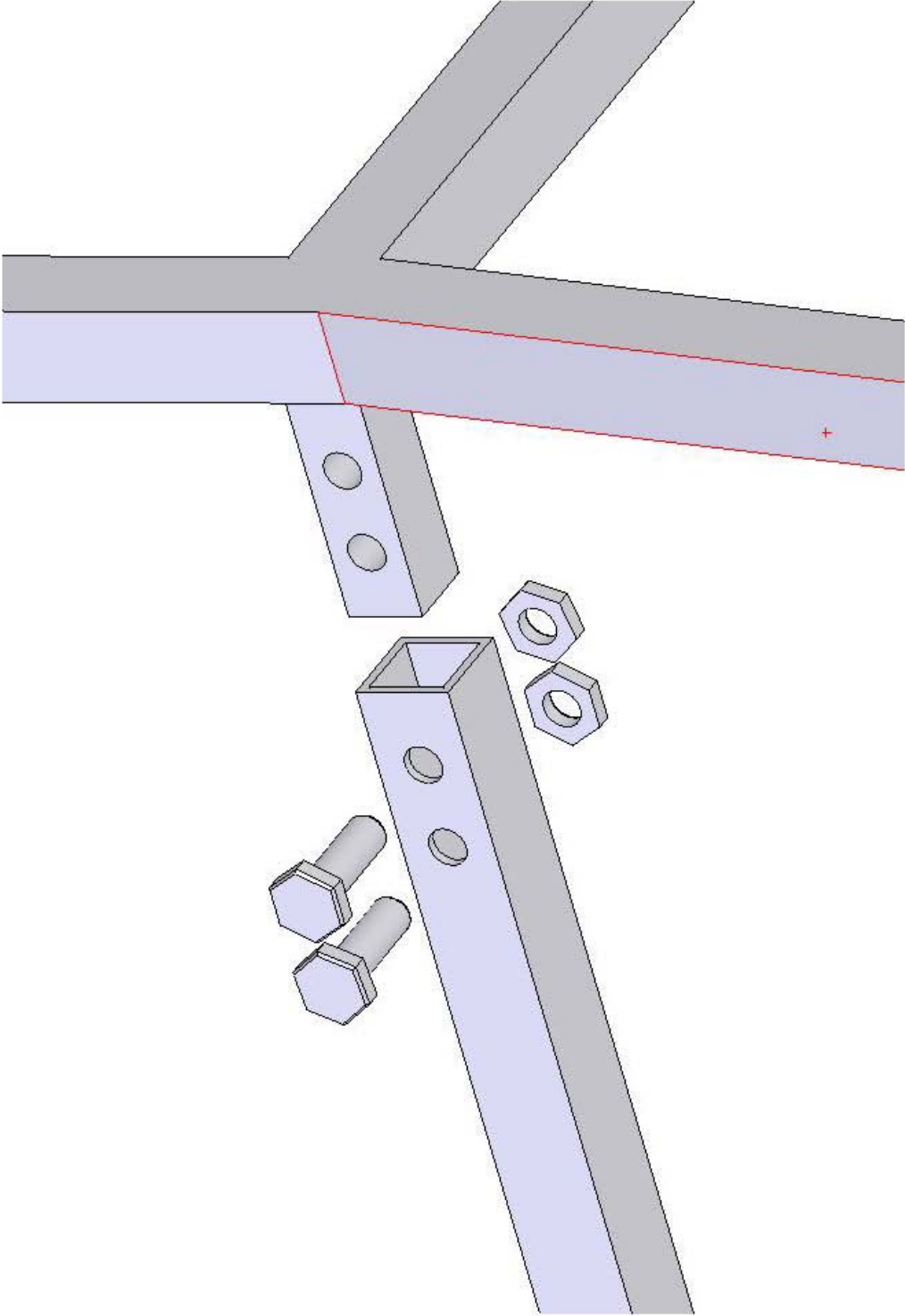

Base Assembly

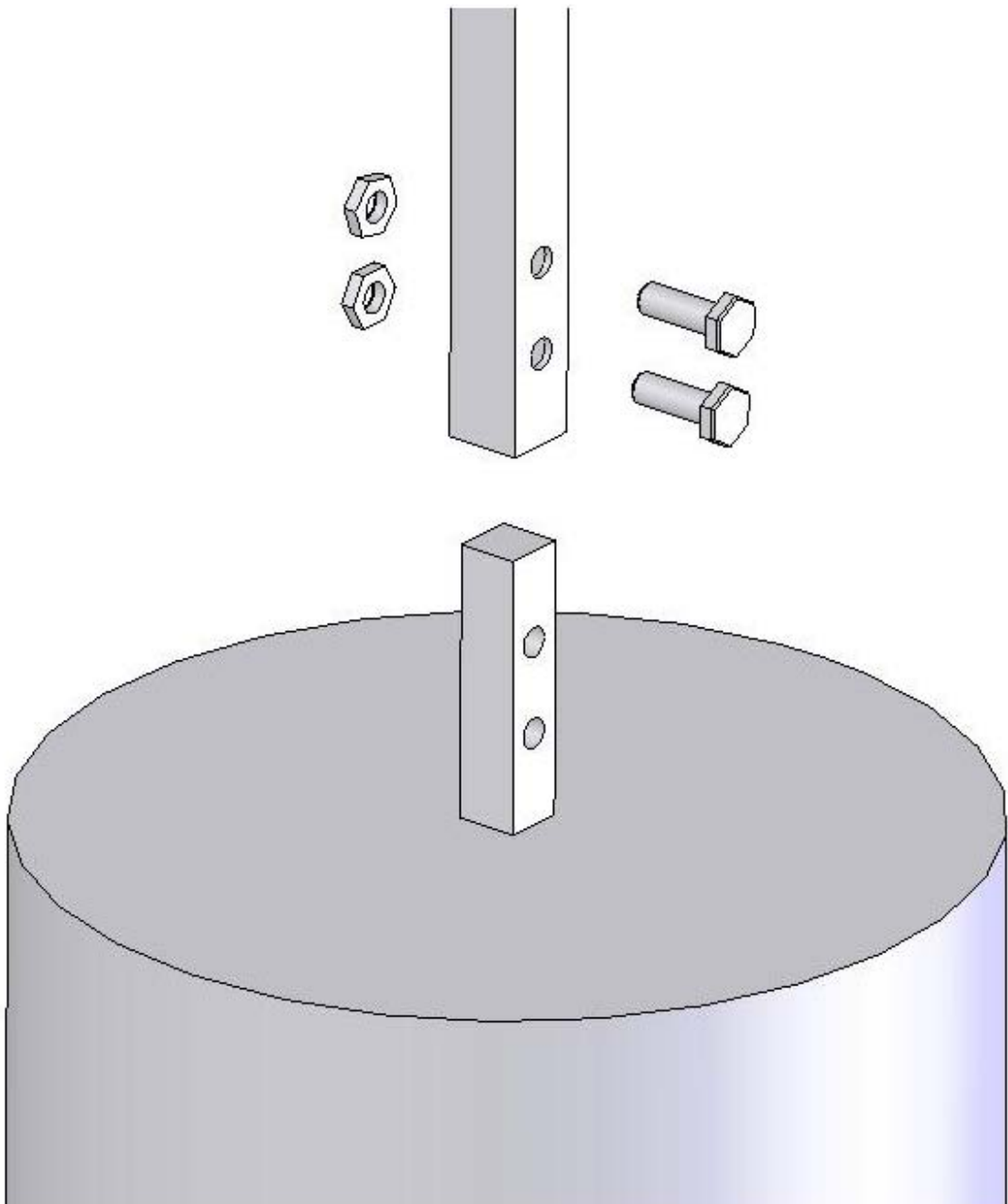

ADDITIONAL INFORMATION ON CONSTRUCTING A HYDROPONIC SYSTEM

The following information provides design specifications and a list of materials for the construction of a hydroponic system. All dimensions in the CAD drawings are given in centimeters. The next three CAD drawings show the dimensions for the hydroponic system's frame.

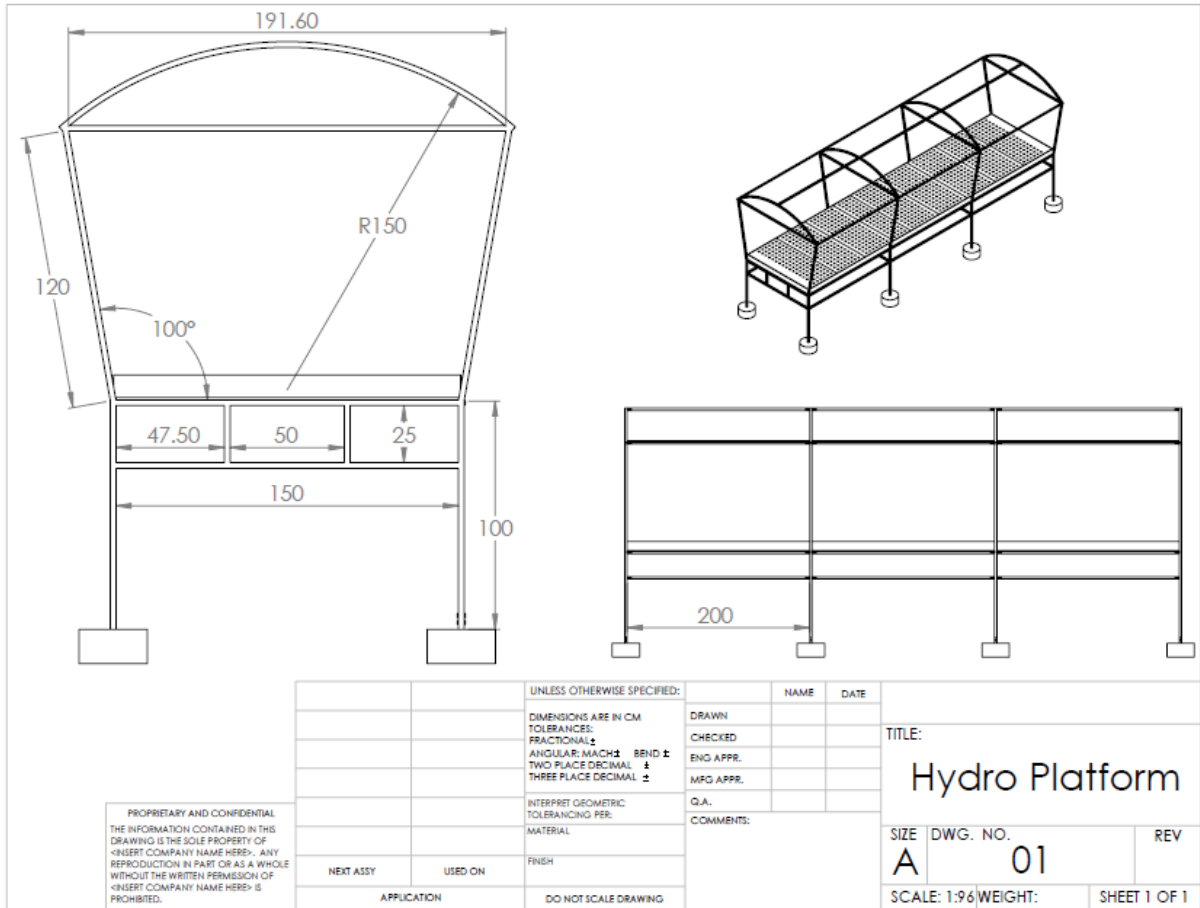

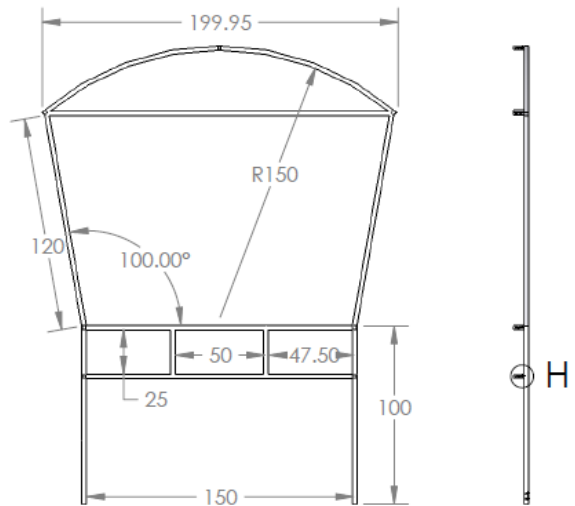
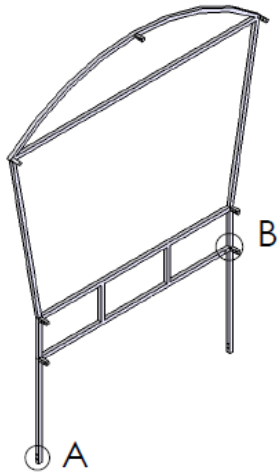
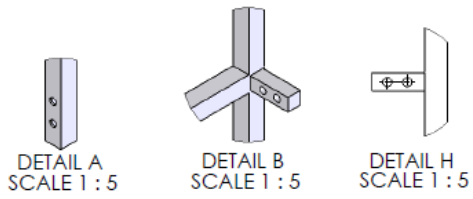

UNLESS OTHERWISE SPECIFIED: DIMENSIONS ARE IN CENTIMETERS SURFACE FINISH: TOLERANCES: LINEAR: ANGULAR:				FINISH:	DEBUR AND BREAK SHARP EDGES	DO NOT SCALE DRAWING	REVISION
DRAWN	NAME	SIGNATURE	DATE			TITLE:	
CHK'D						Frame Ends	
APP'VD						DWG NO.	04
MFG					MATERIAL:		
Q.A							

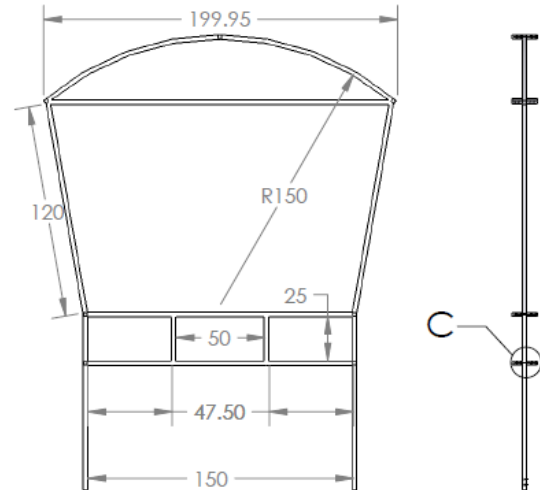
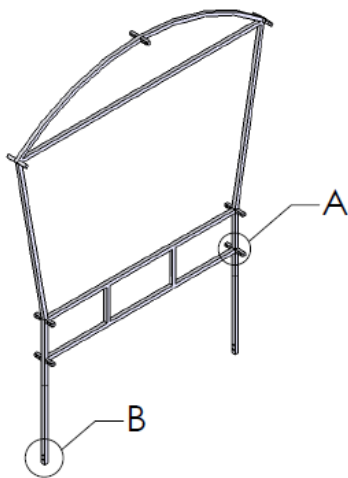
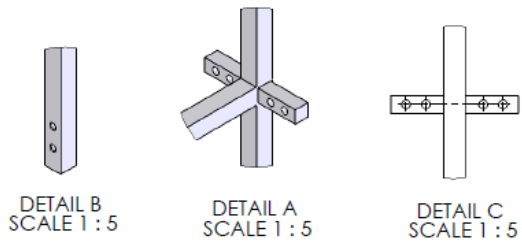

UNLESS OTHERWISE SPECIFIED: DIMENSIONS ARE IN CENTIMETERS SURFACE FINISH: TOLERANCES: LINEAR: ANGULAR:				FINISH:	DEBUR AND BREAK SHARP EDGES	DO NOT SCALE DRAWING	REVISION
DRAWN	NAME	SIGNATURE	DATE			TITLE:	
CHK'D						Mid Frame	
APP'VD						DWG NO.	03
MFG					MATERIAL:		
Q.A							

The CAD drawing shown below instructs how to cut a 2 inch thick Styrofoam board into the ridges which are used to create the channels of the hydroponic bed.

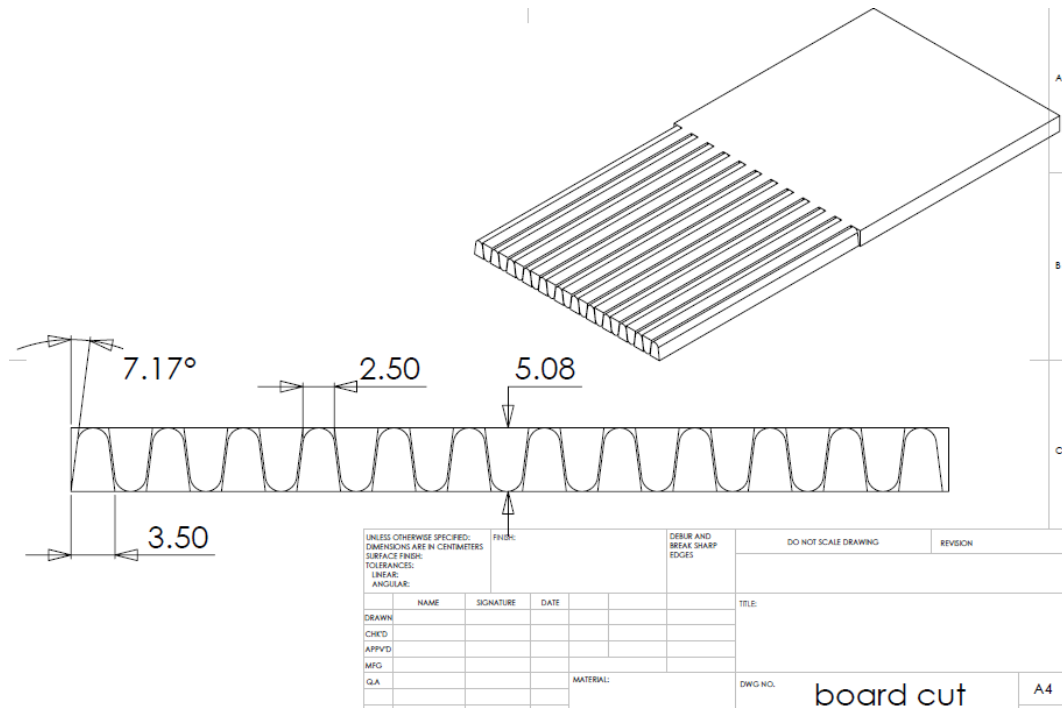

This CAD drawing dimensions the layout of the ridges in the hydroponic bed.

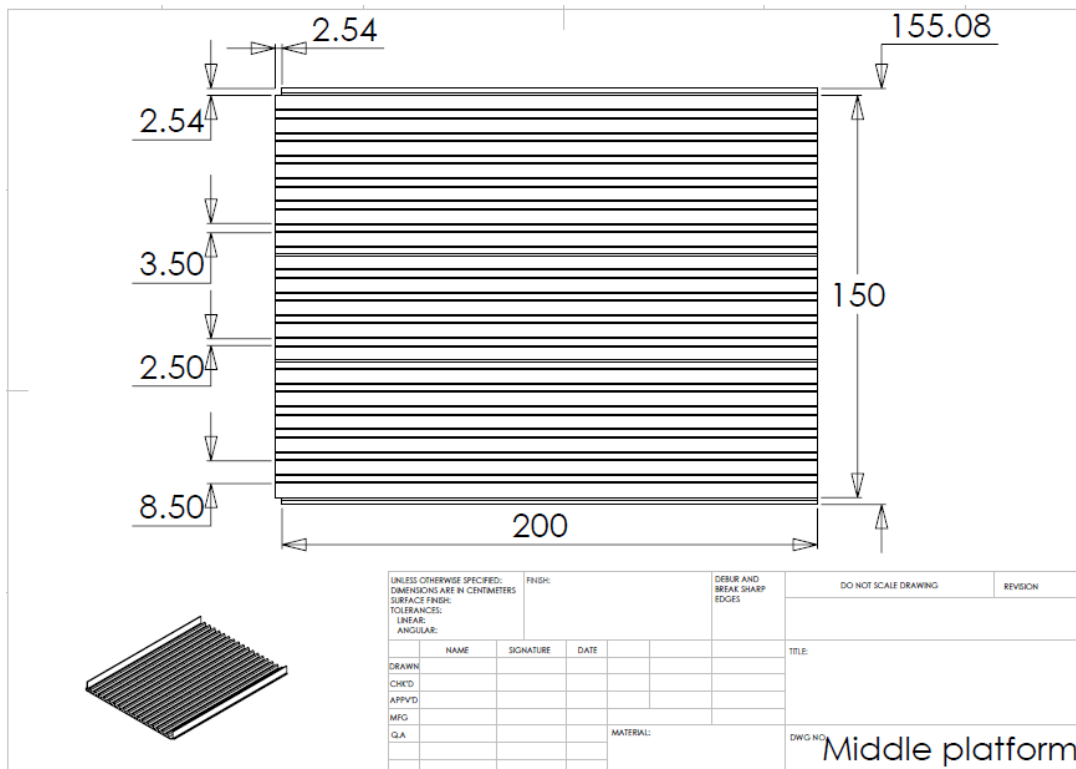

The CAD drawing below shows how the hydroponic bed was cut to make the system modular.

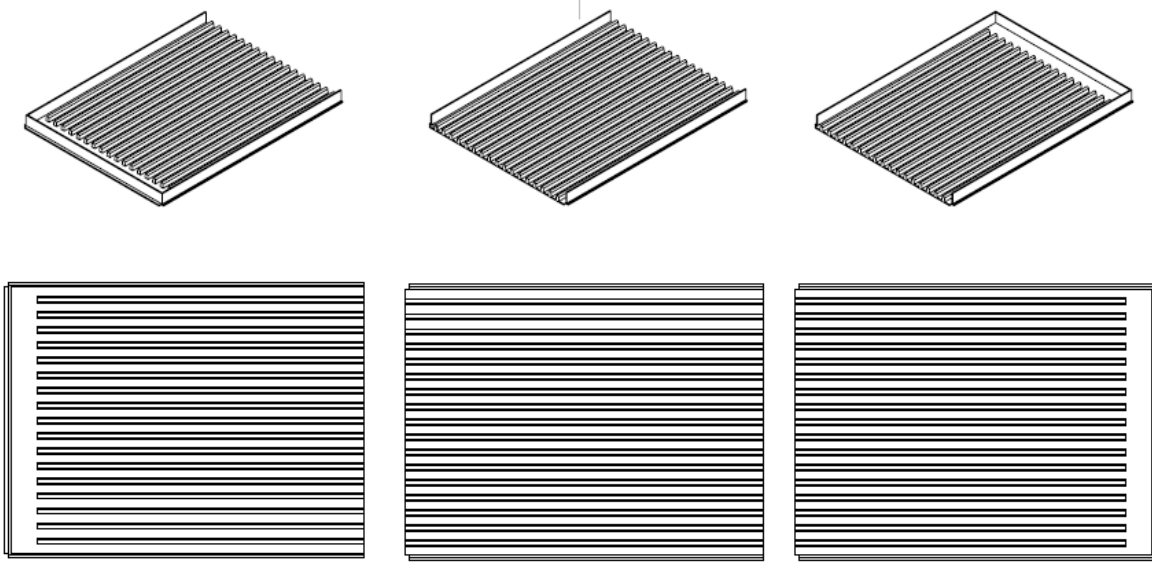

UNLESS OTHERWISE SPECIFIED: DIMENSIONS ARE IN CENTIMETERS SURFACE FINISH: TOLERANCES: LINEAR: ANGULAR:				FINISH:		DEBUR AND BREAK SHARP EDGES		DO NOT SCALE DRAWING		REVISION	
								TITLE:			
DRAWN	NAME		SIGNATURE		DATE						
CHK'D											
APP'VD											
MFG											
Q.A							MATERIAL:		DWG NO.		
									platforms		

The list of materials given below includes the materials used for our project while also including the estimated quantities or amounts.

Materials	Quantity/Amount Needed
1" Square Steel Tubing (1/8 " wall thickness)	108m
3/4" Square Steel Tubing	10m
Nuts, bolts, washers	50 +
Concrete feet	4 units
Rust Resistant Paint Primer	1 unit
Plywood	10.5 m ² minimum
Styrofoam Boards 1" thickness	11 boards (120cm X 70cm)
Styrofoam Boards 2" thickness	4 boards (120cm X 70 cm)
Polyethylene Transparent Sheeting	(3 X 7)m
Polyethylene Black Sheeting	(2 X 14) m
Mosquito Netting	(2 X 15)m
Plastic sheeting to block some sunlight	(3 X 7)m
Clip locks to attach plastic to frame	50
PVC Pipes	8m
Plaster to seal drains/pipes	1 tube
Adjustable Length Drainage Pipe	1 pipe
Water Tank (needs capacity of 500 L)	1
Aquarium pump with filter and air bubbler	1
L-Brackets and Screws	16

Additional materials needed for growing of the vegetables are:

- Seedling tray
- Sponge
- Seeds
- Liquid fertilizer (two types)
- Measuring container
- ph test kit (litmus or meter)
- Water concentration test kit (EC meter)
- pH buffers

Prices for materials not purchased for this project.

Item	Price (Baht) per unit	Quantity	Total price
Estimates from Mahasarakham Local Market			
Temperature Reducing Material	270	1	270
Mosquito Netting	40	15	600
PVC Piping	29	8	232
Market Price Obtained from ACK International and FAO/WTF Case Study			
Sponge	0.1	700	70
Seedling Tray	60	4	240
litmus	295	1	295
Seeds	0.1	800	80
pH buffer	325	1	325
Fertilizer	140	2	280
Total			2392

APPENDIX C: PAIR-WISE COMPARISON CHART

Pair-Wise Comparison Chart

	Low Cost	Durable	Easy to Operate and Maintain	Replicable	Modularity	Suitable for Healthy Vegetable Growth	Total
Low Cost	X	0	0	1	0	0	1
Durable	1	X	1	1	1	0.5	4.5
Easy to Operate and Maintain	1	0	X	1	1	0	3
Replicable	0	0	0	X	1	0	1
Modularity	1	0	0	0	X	0	1
Suitable for Healthy Vegetable Growth	1	0.5	1	1	1	X	4.5

APPENDIX D: SUMMATIVE TEAMWORK ASSESSMENT

Throughout the course of this project, our group completed three formative teamwork assessments. These assessments required each team member to identify a strength, an area for improvement, and suggestions on how to improve upon this area. Each team member did this for themselves, the other members of the team, and for the team as a whole. Initially, we were also completing a qualitative rubric as part of the assessment to further evaluate our work, but we found that it was not very effective and decided not to continue with it. We would complete the team assessments on our own time and then regroup to discuss our thoughts. We found that our teamwork assessments were a very effective way of sharing our ideas and feelings of how to make our project run more smoothly and efficiently. This section includes a review of our team as a whole, followed by individual self-assessments, and finally a group summary of each individual's contributions.

Team Assessment

Over the course of our project work and through our team assessments, we have been able to identify areas of strength for our team. One area of strength that we identified was that we were able to keep a positive attitude towards our project despite any setbacks that we encountered. We also believe that we communicated effectively and respected each other's opinions during team discussions. In addition, we feel that we found an effective way to edit our drafts. Typically, we would individually read through each draft and make comments and regroup to review the draft together. We found that this was an efficient way to hear everyone's feedback and to find any errors in the report.

In addition to identifying our team's strengths we also determined our weaknesses as a team and as a result, made adjustments to help our team function more efficiently. On the first team assessment, we determined that one of the teams' weaknesses was that we were having difficulty staying on task throughout the day. As a result, our team worked to motivate each other if we noticed that one of our group members was losing focus. We also decided that an effective way to keep the group focused throughout the day was to create a list of tasks that needed to be accomplished at the beginning of the day. This way, if a group member needed something to do or was stuck on a part of the project, they could refer to the list and find something that they could do.

Another example of how we used the feedback from our team assessments to improve our group dynamic was when we identified that we sometimes tended to only do parts of the project that we were comfortable with such as writing or gathering materials. Through our team discussion, we all agreed that it would be beneficial to the team if we switched up who stayed in the office and who went out to purchase materials more often. After this team assessment, we all spent more time going outside of our "comfort zones" and switching up the combinations of people who would stay in the office and who would leave. By doing this, our team was able to experience and better understand different aspects of our project.

Our group also faced the challenges of teamwork at times throughout our project. For example, when approaching deadlines such as our first draft of the final report, we sometimes did not have the time to be able to discuss everyone's writing in as much detail as usual. In these situations, the stronger writers had to take more control in the team and others were more productive in tasks such as peer editing and formatting. While this imbalance may not have been able to allow for even contributions, it was necessary to meet the deadlines. After crunch time, the balance of our team and our effective process of reviewing and communicating returned.

Another challenge that we faced during our project work was that we had to spend four weeks with just our team in Mahasarakham for field work. In Mahasarakham, there were not many other westerners so often times our only interaction outside of work would be amongst ourselves. We were put in a position where conflicts could have easily presented themselves within the group which could have been detrimental to our project work. Instead, we kept a professional attitude and were able to work as a team to separate our work lives and personal lives. We did this by appreciating the time we spent together both during and outside of work, but also giving each other our personal space when we needed to.

Throughout the course of the project, our team gained some very valuable knowledge about team dynamics. We learned that it is important to communicate with group members and to consider the opinions of others before taking action. Our team assessments helped our group to work more effectively and respectfully together. We were able to provide each other with constructive criticism and suggest ways to improve. This contributed to our group's ability to address and overcome challenges in order to successfully complete our project.

Individual Self-Assessments

Aubrey Ortiz

I believe that I am a reliable team mate as I am almost never late to group meetings unless there has been a misunderstanding on meeting times. I also never missed a day of work due to reasons under my own control. I almost always have my work finished on time, and when I finish my work early I try to find new things to do for the project.

Whenever any my teammates identify an issue with me, I am never defensive and do not get angry at them. I use their suggestions and try to improve myself. For example, when one of my team mates said I need to be more vocal about my opinion in the group, I became more persistent with my opinion and argue if my team members don't agree. If I cannot convince my team mates on a disagreement and have a strong opinion on something such saying if we were "from WPI and Chula, or just from Chula" during the presentation introduction, I am willing to go to an advisor to settle the disagreement. Another example was when a teammate said I needed to pay attention more during group editing sessions; I improved by following along with the group during editing sessions and not reading ahead or behind them.

I believe I can critically analyze my strengths and weaknesses as a team member from the perspective of others. When I wrote myself assessments, it is always very similar to what my team mates have written about me.

I regularly share my feelings and opinions during team assessments. Whenever I give feedback to a team member, I try to identify a specific example included with the team member's general characteristic in order to help them understand where my constructive criticism is coming from. I also always give suggestions on how to improve and give them feedback on how they performed compared to the previous team assessment. I support my team member's efforts to improve and I never become too upset with my team members and blow up.

Hilary Rotatori

I feel that throughout the course of this project I have proved myself to be a reliable team member by being consistently prepared and on time for all team meetings and presentations. I put forth my best effort in my writing for the report and I think this is reflected in the quality of my work. I think I have demonstrated my dedication to the project by putting in extra hours on many occasions and volunteering to do additional parts of the project such as compiling and summarizing the formative team assessments. I feel that I have put my best effort into editing our report so that quality drafts are submitted to the advisors.

I feel that one of my strengths as a team member is my ability to take constructive criticism and act upon it. Throughout our teamwork assessments, I have genuinely considered the input of my group members and taken specific actions to improve. For example, during our field work in Mahasarakham, our group conducted a team assessment that suggested that I should be more active in the procurement of materials and construction of the system. Following that assessment, I was more active in leaving the office to gather materials for the system and also played a very active role in the construction of the hydroponic system. After the team discussion, I was able to recognize this weakness and as a result, I took action to resolve this problem. Another example of how I have considered my strengths and weaknesses from the perspective of others is when it was suggested in a team assessment that I sometimes tend to be a "last minute worker". In order to address this issue, I worked throughout the project to have things done beforehand to allow myself time to do other things such as edit my own work or the work of other group members. My teammates also determined that sometimes I have difficulties getting started on a task. I have tried to resolve this issue by identifying when I am stuck on a task and either starting a new one and returning to it later or asking for a teammate's help to get me started. I have found that this is effective because I can efficiently complete the task once I get a good start on it.

In a group setting, I feel that I am able to effectively convey my opinions and elicit those of others. I focus on giving constructive, actionable feedback to my team members and suggest specific ways to improve. For example, if a group member was having trouble focusing

during the day, I would suggest that the group member communicate this to the group and perhaps take a five minute break. In addition to providing constructive feedback to my group members, I feel that I am a good listener during team discussions and assessments. By paying close attention to the opinions of my group members during team assessments and during our project work, I have been able to identify areas of improvement for myself, my project partners, and the group as a whole.

Elizabeth Schreiber

Throughout this project I feel that I have grown as an individual and as a team member. I have demonstrated the characteristics of a good team member and have also worked to improve the team's overall improvement. Over the course of the project, I have consistently been a reliable group member. I consistently finished my individual work for the project at the time our group specified, as well as arriving on time and being prepared and ready to work at 100 percent. In addition, I have also been able to motivate myself and the group by outlining the necessary tasks to be done and making sure they are being completed.

As an individual I have been able to recognize my own strengths and weaknesses and accept what others have to say about me. I have been open to discussion about my strength and weakness and was willing to try and find a solution to improve myself. In the first formative teamwork assessment the team determined that I could improve on my presentation skills. I identified that in order to improve upon this I would have to practice more to become more comfortable and I would need to try to be more relaxed and confident. I feel that I accomplished this because in the subsequent presentations and especially the final presentation I knew my material well and was confident and relaxed. Also the group decided that I could improve on being more comfortable with outside people. Instead of continuing to be shy, I did the opposite in the next few weeks and in the next formative teamwork assessment the team identified that one of my strengths was asking the right questions of people to clarify our project or the report. Lastly, I became active in the construction of the system after I had previously been staying in the office most days writing the report. Overall, I think that I positively responded to comments made on my strengths and weaknesses by identifying specific ways of improvement and following through with them.

During our group work I would communicate with the group about my feelings or opinions. I would always share my thoughts and then listen to those of my group members. If a conflict arose, I felt that I equally was able to support my opinion and also listen to others. I also was able to give my group members constructive criticism while including at least one specific suggestion on how to improve. I would try and help my group members improve by encouraging positive actions and congratulating them when I noticed an improvement.

I think overall I have grown and developed into a strong individual and group member who can recognize their strengths and weaknesses and take action to improve while also supporting my group members. This was something I have been able to focus and work on

throughout this project and I intend to use this kind of strategy in future teams that I will be in.

George von Roth

Personally there have been some very challenging parts of this IQP that I believe have tested and strengthened my teamwork skills. In the beginning of the project, when we had many design and construction goals I was very much in an area where I felt comfortable and productive. I have learned through many daily struggles that one of my strengths is the ability to find solutions on the spot. We were put in many positions where we needed to solve a problem but lacked the time or resources to do it thoroughly. An example of this was on the second to last day of construction we realize we had inadequate tools to cut the foam. With a few minutes of brainstorming with the group I was able to implement a crude jig that would allow someone to cut the foam accurately with just a hacksaw blade. I have never had to come up with solutions on the spot like we were required to during our IQP. This is an important skill I've discovered that I feel will always be useful.

During the weeks in Bangkok, our project was much more report oriented. Writing report style papers was not a strength of mine. While I feel I am very good at communicating ideas, writing them down in a format not my own in collaboration with other people's work can be very challenging. In order to be productive during this part of the project I had to adapt my ways of writing in a way that would make them work in a team environment. When writing alone I outline the entire report and keep adding to the outline until all information is there and it needs to be converted to sentence form. However, in a project this size, this method cannot be done. To adapt my style I would confer with team members on which parts I would be responsible for writing. I would then begin my outline on that section covering the main points discussed with the team. This would allow me to write in my own style without attempting to tackle too much information or begin work on parts I do not fully understand or someone else could do better. Stepping out of my comfort zone of design engineering and working my best at contributing my share in writing the report was personally the hardest part of the project.

I also became more comfortable in discussing problems within the team. Due to WPI's schedule most team project work is over within 7 weeks. It is often the case that any problems that arise are ignored and avoided because the project will be over so soon. With the IQP lasting for 2 terms it would be devastating to ignore problems as they arose. In the beginning of the project I feel that I was able to bring up concerns through the team assessments, however as the time passed I felt that the team and myself grew to a point where we could address problems more openly without confrontation. When criticized I would do my best to explain if I had an alternative view and then work with the team on a method to address the issue. During the project I have developed a way to confront people on issues that are non-critical, I try to frame the issue in a way that allows me to hear their opinion before voicing my own concern. Working this way as a group allows us to feel more comfortable and less likely to get defensive over issues encountered.

Team Summary of Contributions and Roles

In addition to the writing of the report and other aspects of the project, each individual in the group used their strengths to help them establish roles in the group that helped us to work together more effectively.

Aubrey Ortiz

Along with George, Aubrey took a major role in knowing the technical aspects of the project. He was the most knowledgeable about hydroponic techniques and therefore took the lead in designing the hydroponic bed. Aubrey was a hard worker and became more confident with voicing his opinion within the group over the course of the project.

Hilary Rotatori

Along with Elizabeth, Hilary took a lead role in the writing of the report. She took the responsibility of evenly dividing up the work to be completed. It was identified that Hilary is a good person to bounce ideas off of because she thinks out loud and is good at communicating with the group. Hilary was good at organizing her thoughts on paper and connecting key ideas in the report to help it flow better. She was also good at editing the report to make it more concise.

Elizabeth Schreiber

Along with Hilary, Elizabeth took a lead role in the writing of the report. She also took the role of outlining main writing objectives that our team needed to achieve. Elizabeth was very effective in getting the group to re-focus if anyone was not on task. She was responsible for keeping the most recent versions of the report updated. Elizabeth was also helpful during discussions with the advisors by asking the right questions to help our team.

George von Roth

Along with Aubrey, George took major roles in the technical aspects of the project. He also used his experience in design engineering to help him in the role as head designer of the hydroponic frame. George is also a good team member to brainstorm with because he can give other team members ideas from another viewpoint.

APPENDIX E: TEAM MEMBERS' CULTURAL ESSAYS

Aubrey Ortiz

The situation being described occurred on Thursday night January 22, 2009. Our sponsor, Ajarn Andrew, thought it would be a good idea for our team to socialize with the Thai SIFE students, so he set up a night for us to go bowling with the students and his two children. Earlier that morning, Ajarn Andrew convinced another professor, Ajarn Deaw, to also come bowling with us. Ajarn Deaw lived in the same residence as us and he agreed to pick us up at 6:30 PM because we had no easy mode of transportation to the bowling alley.

Hilary, Liz and I dressed up and sat outside the condo at 6:30 PM and waited to be picked up by Ajarn Deaw. We waited until 6:50 before we decided to call Ajarn Andrew, as we did not have Ajarn Deaw's number. Ajarn Andrew picked up and told us he would call Ajarn Deaw to see what was wrong. We thought that perhaps Ajarn Deaw said he was going to pick us up at 7:00 and that we misunderstood. However, Ajarn Andrew called us back to explain that Ajarn Deaw was at a school meeting with the Dean and was just leaving to pick us up. 7:00 rolled by and there was still no sign of Ajarn Deaw. Finally a few minutes later, Ajarn Andrew called us to say that the students cancelled on us because they had no way of getting to the bowling alley.

According to William J. Klausner from "Reflections on Thai Culture", many Thai people don't perceive time the same way as Americans do. Instead, many Thai's view time as polychronic, or view time as an unlimited good. Therefore, being exactly on time or on schedule is not very important. For Ajarn Deaw, it wasn't imperative that he had to be on time to pick us up or let us know he was going to be a little late. After all, we were going to the bowling alley for fun instead of needing an emergency ride to the hospital.

Our Thai language and culture teacher, Aj, Sumalee explained that Thai people rarely say "no". In Thai culture, saying outright "no" is considered rude and inconsiderate. In order to not appear rude, some Thai people will say "yes" if asked a question such as being invited to an event. However, saying "yes" to somebody is not a full promise that they will come. I believe this might explain why the Thai SIFE students agreed to go bowling with us when asked by Ajarn Andrew and then later not show up. Since Ajarn Andrew is their professor they might have felt pressured to agree even though they didn't want to or were too busy to come. Instead, they did not show up and made some poor excuse such as all of them not having transportation to the bowling alley. The students most likely did not want to be rude to Ajarn Andrew so they agreed to come even if they had no intention of doing so.

Although I was a little bit annoyed that Ajarn Deaw had not showed up, I understand that my perception of time is different from many Thai's perception of time. In Thai culture, it is not uncommon for people to be late or reschedule plans, even in a professional setting. Therefore if I were Thai it wouldn't really mind if someone showed up late or did not call in advance.

When I heard that the bowling event was cancelled, I was disappointed as I was looking forward to socializing with the Thai students out of an academic setting. However, I can understand that the Thai students possibly did not want to show disrespect to their teacher. If I was Thai I would not want to be rude to my teacher either, especially since teachers are held in very high regard in Thailand. If I ever invite a Thai person to an event, I will keep in mind Ajarn Sumalee's suggestion to be persistent yet polite until I receive a definite confirmation.

Hilary Rotatori

As an American immersed in Thai culture, it is easy to misinterpret even simple interactions or situations with the Thai people. In order to try to understand the reasons behind the traditions of Thai culture, it is important to reflect upon and learn from these situations. One way to do this is by using the Describe-Interpret-Evaluate (D-I-E) model introduced in the text *Maximizing Study Abroad*. This method can help us to better understand these situations and the cultural reasons behind them. The first step is to describe the situation, followed by the formulation of different interpretations of what was experienced, and finally an evaluation of your feelings and how those feelings would change if you were a member of the opposite culture.

I encountered a situation while my group was doing our field work in Mahasarakham. Our group decided that it would be beneficial to meet with the president of the Mahasarakham University SIFE chapter regarding our project. We wanted to speak with her first before scheduling a meeting with the rest of the SIFE team. One of our group members called the president, a Thai student from MSU, to arrange a meeting time. She volunteered to meet with us the next morning at ten o'clock to discuss the design of our hydroponic system and other details related to our project. Later on that day, one of my teammates saw her around campus and she told him that she was unable to make the meeting because she had class at that time. Since this occurred near the end of our stay in Mahasarakham, we were unable to reschedule the meeting with her or formally speak with the SIFE team about the design before beginning construction.

There are a few different ways that this situation can be interpreted. One explanation is that the Thai student felt obligated to schedule a meeting with us even though she knew that she could not make it. In the collection of essays written by cultural expert William J. Klausner entitled *Reflections on Thai Culture*, Klausner explains that in general, Thai people try to avoid personal confrontations. He gave the example in his essay called "Work Ethic" that a servant may tell his employer that he is only leaving for a few days when in actuality, the servant has no intention of returning. This is because the servant does not want to cause a conflict by telling his employer that he is leaving his job. Similarly, the Thai student may have been too nervous to tell us that she was busy and to avoid conflict, she said she was available. In addition, during our Thai language class, Ajarn Sumalee mentioned a few times that when asking Thai people for directions, they may give you an answer even if they are not sure that it is correct. She explained that in general, Thais will feel obliged to try to help you or make commitments that they know they are unable to make in order to avoid disappointing

others. These reasons help to justify why the Thai student was hesitant to tell us that she was not available to meet with us and better explains why she may have scheduled a meeting she could not make.

An additional interpretation of this situation is that the Thai student was just trying to be a good host for our group. We have been told by Ajarn Sumalee and our advisors Ajarns Rick and Chrys that the Thais are usually very welcoming hosts and will do anything to ensure that you are happy and comfortable. Since we were guests at MSU, the Thai student may have just been trying to be a good host and make us happy by agreeing to a meeting time that was inconvenient for her.

Another explanation for the Thai student's actions may have been that her class was rescheduled during the time period between when we decided on a meeting time and when she saw my group partner on campus. We were told by both the SIFE students and our project sponsor that classes at MSU and other Thai universities are often rescheduled on short notice due to religious holidays. Another cultural reason for this occurrence could be that since the Thai student and my group partner met for only a brief amount of time, she was unable to fully explain that her class time had been changed. While she did speak fairly good English, she may have felt that it was too complicated to try to explain the full situation to my group partner in passing.

A fourth interpretation for this encounter was that the Thai student simply forgot that she had class when she scheduled the meeting with us. We learned through our interactions with the SIFE students that they are very dedicated to their schoolwork. In addition, we were staying in Maharakham during their mid-term and finals period which is a very stressful time and the president of the SIFE team may have been so busy with her schoolwork that she agreed on a meeting time before checking her schedule.

In order to evaluate the situation better, I analyzed my feelings at the time of the incident. When this first occurred, I had negative feelings because I felt that meeting with her was very important to the progress of our project. The situation also made me wonder that if she had not coincidentally seen my group partner that she may have waited until the last minute or maybe not tell us at all about not being able to make the meeting. I did not understand why she would have scheduled a meeting for a time when she was unavailable. I also felt upset and felt that perhaps she did not value our meeting as much as I did.

After evaluating the situation, I realize that these feelings might have been different if I were Thai and held the dominant values of their culture. If I were a Thai student hosting a group of international students, that I would feel obligated to make every effort to meet their needs, even if it may not be possible. Whether she realized that she had class or not, she may have just scheduled a meeting with us because we asked her to and she was afraid to deny us help. Additionally, if I were Thai, I would know that sometimes classes are rescheduled on short notice due to religious holidays and I would understand the importance of attending class to a Thai student. From this experience, I have learned that it is important to keep an open mind

and not jump to conclusions, especially when you are experiencing a new culture. The Thai student had good intentions by trying her best to accommodate our group even though she may have been very busy. By analyzing similar situations and considering all the perspectives involved, I feel that I have increased my level of cultural self-awareness and learned much more about the Thai culture during my stay in Thailand.

Elizabeth Schreiber

Living in a different and new culture can be a very challenging experience. In one culture a situation or action may mean one thing, but in another culture means something completely different. This is all due in part to the fact that each person grows up in their own culture that is normal to them. One person who has tried to understand another culture that is not the same from the one he grew-up in is William J. Klausner. Born in New York, Klausner spent 30 years in Thailand and became very knowledgeable about the Thai culture. He wrote a collection of writings about the various aspects of the Thai people from his various experiences. I myself am trying to understand a different culture and have tried to do so through one specific example.

Description

During my project work in Mahasarakham, Thailand, a situation occurred between my project group and a few Thai students from an extracurricular organization that we were working with. Our group decided that we wanted to meet with some of the students to discuss some of our ideas and to hear their opinions on the project. We called the president of the organization, who we had been in regular contact with since the beginning of the project, to set up a meeting. We spoke with her about her availability and assured her that we could meet anytime of the day. In the end, we agreed that we would meet with a small group of students from the organization at 10 am the next morning. Later that afternoon, one of my group partners was walking in one of the buildings and saw the president of the organization. In conversation she mentioned that she and the other Thai students had class at 10 am in the morning and would not be able to meet us. No other mentioning of rescheduling the meeting was discussed. Once I had heard this news I was confused to why they had chosen that time and why they had not told us they could not make it. Since we were busy finishing up our project in the days following this incident, we were unable to meet with the Thai students from the organization. Thus, we did not have a chance to talk with them in person about our ideas and their opinions for our project.

Interpretation

From my general understanding of Thai culture and using the literature from William J. Klausner, I have developed a few interpretations to why I think this situation occurred. The situation I believe could be explained at two different parts, either when the president was originally talking on the phone or when she did not inform us that they would not be able to make the meeting.

For the first part of the situation, I think that one interpretation is that when the president scheduled the meeting on the phone she was not prepared to try and figure out a time to meet us. She might not have wanted to let us down and not show her hospitality for us, so she agreed to a time before thinking about whether or not she was actually available. I believe this is a possibility from what my Thai language Ajarn told us before we came to Thailand. She had said that generally most Thai people are extremely friendly and welcoming to their guests and do not like to feel like they cannot help or provide from them. For this reason, I think that the president may have felt pressured into giving us an answer on the spot, in order to help us and meet our need, before she had thought about her schedule for the next day.

A second suggestion, that is more generally, is that the class was re-scheduled and she either had not known or had forgotten. This is possible because the class schedule at the Thai University is complicated and I did not thoroughly understand it. Although this is a common mistake people can make in any culture it usually does not follow by someone also not informing the other person that they cannot make it.

For the second part of the situation I think there are two different interpretations. One is that when the president realized that they could not come to the meeting they did not want to have to tell us that. This could be because they did not want to let us down or they did not want to confront us. I interpreted this because Klausner suggests that many Thai people will avoid confrontation and thus will usually let something go rather than addressing the problem. From this, it could be interpreted that the president was going to just not show up the next morning in order to avoid telling us she could not come.

Another reason for not telling us could be that the president did not feel a need to have to tell us. From Klausner's experiences, he has found that most Thai people are not overly concerned if they are late or do not show up for a meeting because something else came up. Also, this same idea was repeated to me from my Ajarn and my sponsor. This could have been the case with the president and was the reason why she did not call us as soon as she found out that they could not make the meeting.

Evaluation

It is from this situation that I have been able to think about and understand a number of different cultural aspects of Thai culture that are different from my own. Originally, I felt that the president should have agreed on a time she knew she could make and if she realized that she could not make it then to tell us soon afterwards. Now after analyzing this situation I think that I better understand the Thai values of confrontation, time and hospitality. I understand that if I were the president I would want to be able to help us and if I could not I would not want to have to confront us. Next time I am approached with a situation in another culture I will try and analyze it from the point of view.

George von Roth

Description of Event:

Today we go to the village of Ban Ma Kok to get specific details of an old hydroponic system. We're prepared to leave but discover we have no tape measure. This should not be a problem; Ajarn Andrew will just go ask for one downstairs. However, the person to ask is not around. We decide to ask a woman sitting at a neighboring desk. She says that the person who has one is not in yet and she calls to see when we can get the tape measure. A short Thai conversation later and we are told that the man we need will be at the office in one hour (eleven o'clock) and we should come back to receive the tape measure then. We give our thanks and head back upstairs to work for the hour.

After the hour has passed, Ajarn Andrew calls down to check if the person has arrived. He has not, but he will be in shortly and they will call us once he arrives. Twenty minutes later, with no phone call we decide to call down again. This time we are told again that he will be arriving in twenty minutes. We still have work that can be done so we are able to be productive for the next twenty minutes. Once the time has passed with no phone calls, we decide to go down ourselves. When we find the woman, she tells us that he still has not arrived and will be here within half an hour. At this point we decide that the 34 baht for a new tape measure would be a minimal expense and allow us to leave for the village. We are then told enthusiastically to "Wait! Wait!" because he *will* be here soon. Fearing this may not be true, we thank her and leave to purchase our own tape measure and continue on to the village.

Interpret:

After some thought about what happened I feel there are several ways to interpret what happened that morning. My first explanation is based off of Klausner's opinion on the Thai's regard for time. According to Klausner, being on time is not as much of a concern to many Thais as it is to many Westerners. Perhaps the man with the tape measure really was planning on arriving around 11, however something came up and being somewhat late is not of great concern and he can explain when he arrives.

Another possible reason for the multiple delays that's not due to differences on the value of time could instead be an issue of trying to be helpful. Our Thai language and culture teacher, Ajarn Sumalee, explained that in Thai culture many people do not want to disappoint and will even make up information to try and be helpful. It is possible that the woman was not sure when the man was going to arrive and when we asked how long she made a guess that it would be within an hour. Possibly this man usually arrives at eleven, but today was different, and instead of answering our questions with the awkward and unhelpful 'I don't know' the woman felt giving an answer would be better.

A different interpretation is derived from our sponsor, Ajarn Andrew's description of the local awareness of others. Speaking from experience in the culture, Ajarn Andrew feels that it is common for Thais to not consider how their actions may be affecting others. The tape measuring man may very well have been on his way and arriving at eleven, however when something came up he did not think of how it would affect others and this unanticipated tape measure request was no reason to notify anyone that he would now be late. Also, the woman

in the office may not have considered that if her estimate of arrival was incorrect what implications it would have on our schedule for the day.

My last interpretation is a combination of all three. The woman downstairs calls and finds out that the man with the tape measure will be arriving at eleven. However, something does come up and the man is unable to keep his time commitment. At this point he knows he is going to be late, however he does not call to inform anyone. He can explain when he arrives and calling to say he will be late will only disappoint and won't get him there any faster. At eleven when we call the lady back to see if he has arrived she is unaware he will be late and tells us twenty minutes in order to be helpful. The combination of these three cultural differences; not as concerned with time, feeling need to help, and the level of awareness of how one's actions affect another's plans make for a situation that can confuse and frustrate us as foreigners.

Evaluate:

I view time as an invaluable source in which everything happens. I've been raised in a culture where 'time is money.' Personally, I feel it can be used, it can be wasted, it is almost always a limitation, and it's hard to ignore. It is this that can cause some frustration here in Thailand when things don't happen exactly on time. When thinking about how a Thai person views this issue I can understand that some foreigners may seem impatient and hypersensitive to time.

The second issue of being helpful and not wanting to say 'I don't know' stems only from good intentions, however, it can cause some misunderstandings later on. Ajarn Sumalee had told us it is very uncomfortable for many Thais to be put on the spot with a question and making up an answer is an easier way out of the spot than admitting a lack of knowledge. This confuses me because in my cultural background it is acceptable to admit being uninformed and admitting it is often more helpful than a guess. Conflicts arise when a foreigner feels lied to and misled. When confronted about it, it must be very uncomfortable for the Thai person because they feel they have helped the best they could and any answer is better than 'I don't know.'

Lastly, a common cultural difference I've encountered on my trip is the seemingly lack of consideration of how one's actions affect others plans. While I am unsure if this was the cause of our morning's frustrations, it is possible the tape measuring man did not think of how the plan of our day may be dependent on when he arrives. While this is a very different way of thinking than I have been accustomed to, I have to try and not get frustrated about changing plans and not being 'in the loop.' It is very hard for me not to compare what happens here with how it would happen back in the United States. However, I think that I have somewhat adopted the D.I.E. process whenever I feel I am in a foreign situation. I try to step back and do my best to not judge the situation but instead try to explain what is happening through several interpretations based on what I've been told about Thai culture and also what I've experienced so far on my trip in Thailand.

**APPENDIX F: EDUCATIONAL MATERIALS: TEACHING
MANUAL, OPERATION MANUAL, AND BUSINESS ACTIVITIES**

Hydroponic System Teaching Manual
Designed for Maharashtra University Demonstration School



Aubrey Ortiz, Hilary Rotatori, Liz Schreiber, George von Roth
Worcester Polytechnic Institute

Created February 2009

TABLE OF CONTENTS

List of Figures	ii
Introduction.....	1
Necessary Background Information	1
Plant Biology.....	1
Suggested Activity: Plant Development Journal.....	1
Hydroponics	2
What is Hydroponics?	2
How Does Hydroponics Work?.....	2
Why Use Hydroponics?.....	3
The History of Hydroponics	3
Suggested Activity: Comparing Traditional and Hydroponic Farming.....	4
Maintaining a Hydroponic System.....	5
Pest and Disease Control	5
Cleaning the System	6
Check PH and Nutrient Concentration Levels	6
Light Control	7
Suggested Activity: Cleaning the Hydroponics System	8
Suggested Activity: Small-Scale Hydroponic System.....	8
Expected Learning Outcomes	9
Plant Biology	9
Science and History of Hydroponics	9
Maintaining the Hydroponic System.....	9
Sources.....	10

LIST OF FIGURES

Figure 1: Styrofoam Boards.....	2
Figure 2: Hydroponic Channels.....	2
Figure 3: “V” Shaped Roots.....	3
Figure 4: Hanging Gardens of Babylon.....	4
Figure 5: Traditional Farming (Left).....	5
Figure 6: Hydroponic Farming (Right).....	5
Figure 9: pH Test Strips.....	7
Figure 10: Algae in the Hydroponic System.....	7
Figure 11: Inverted Soda Bottle.....	8

INTRODUCTION

This teaching manual was created to help integrate the hydroponic system into the agricultural curriculum at the Maharakham University Demonstration School. The first section of this manual includes background topics and knowledge that you may want to teach your students before or during their use of the hydroponic system. Throughout the manual, there are suggested activities for the students using the hydroponic system. There are directions on how to do these activities following each activity description. The activities are intended to be fun and engaging and should help the students learn about the hydroponic system. For each topic and activity there is an expected learning outcome listed towards the end of the manual. The topics and activities can be chosen based on what you want the students to learn. There is also an operation manual included with the teaching manual which explains the operation and maintenance of the hydroponic system.

NECESSARY BACKGROUND INFORMATION

PLANT BIOLOGY

Stages of Plant Life: Germination, Seedling, Plant

Parts of the Plant and their Functions: Roots, Stems, Leaves

Role of Nutrients in Plant Growth

SUGGESTED ACTIVITY: PLANT DEVELOPMENT JOURNAL

This activity will help the students understand the structure and life cycle of plants. The students will be able to see the plants grow and even observe the roots. They will also be inspecting the plants for pests. Each student will be given a plant to monitor during its growth. The students will record information on the plant at least once a week. Here is a sample journal entry:

Date:

Height of Plant:

Diameter of Plant:

Number of Leaves:

Color of Plant:

pH Level:

Pests Found (yes or no):

Additional Observations:

At the end of the semester the students can create a graph that shows the progression of the plant's height through the stages of life. The graph will plot the date of measurement versus the plant's height. A chart of the plants diameter and number of leaves can also be made.

HYDROPONICS

WHAT IS HYDROPONICS?

Hydroponics is a way of growing plants in water with nutrients without using soil. If the vitamins and nutrients are put directly into water the soil is not necessary.

HOW DOES HYDROPONICS WORK?

There are many different methods for using hydroponics to grow plants. One successful hydroponic method used in Thailand is called the Dynamic Root Floating Technique (DRFT). The hydroponic system used at the school is the DRFT.

In the DRFT, plants are grown in holes made in Styrofoam boards as shown in Figure 1. The Styrofoam boards are placed on top of the channels shown on Figure 2. Nutrient water is pumped into the channels and the Styrofoam boards float on top of the water. The holes on the Styrofoam boards line up with the "ridges" on the channels. When the roots grow they will have a "V" shape as shown in Figure 3. This is beneficial because it gives the roots more air space to obtain oxygen.



Figure 1: Styrofoam Boards
Source: Kao, T (1991)

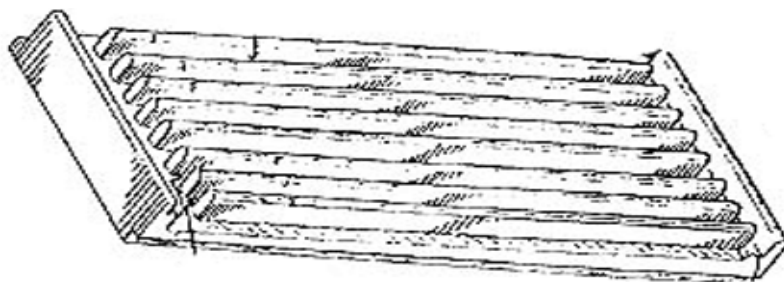

Figure 2: Hydroponic Channels
Source: Kao, T (1991)



Figure 3: “V” Shaped Roots
Source: Kao, T (1991)

WHY USE HYDROPONICS?

Hydroponics has many advantages compared to soil farming. Some of the advantages are:

- Hydroponics is a good way to grow plants if the soil is unsuitable for farming.
- Less water is used when using hydroponics because the water is recycled. Also, less water is lost through evaporation because the water is covered.
- Hydroponic plants can survive with more salty water than soil plants.
- Hydroponic plants grow larger than soil plants because they receive all the nutrients they need.
- The right amount of nutrients can be given to the plants without wasting fertilizer.
- Hydroponic plants grow faster than soil plants. This means there is a shorter harvest cycle, so more can be harvested per year.
- More plants can be grown in an area compared to soil farming.
- Hydroponic farming is easier to maintain and requires less work because the soil does not have to be tilled or weeds removed.
- Because the hydroponic system is elevated above the ground and protected, there are no soil based pests like insects and small animals.
- Hydroponic plants can be grown organically without pesticides. Organic plants are healthier and can be sold for more money than non organic plants. “Super Fresh” is a Thai company based in Bangkok that sells hydroponic vegetables.

The disadvantages for hydroponics are:

- Hydroponic systems can be expensive to create or buy.
- When trying to make a profit only high value vegetables should be grown.
- Hydroponics requires more knowledge than soil farming.
- Disease can spread quickly because all the plants are close to each other and share the same water.
- Some hydroponic systems require constant electricity for the pumps or the plants will dry out.

THE HISTORY OF HYDROPONICS

Hydroponics has been used to grow plants for thousands of years. One of the first recorded uses of hydroponics was the hanging gardens of Babylon in 600 BC, which can be seen in Figure 4. In ancient Egypt, hieroglyphs showed plants being grown in water without soil. The

Aztecs also used hydroponics on their floating gardens known as chinampas in the 1150's. Marco Polo wrote of floating hydroponic gardens in China during his travels (1275-1292).



Figure 4: Hanging Gardens of Babylon

Source: http://en.wikipedia.org/wiki/File:Hanging_Gardens_of_Babylon.jpg

The first modern use of hydroponics was by W.F. Gericke from the University of California during the 1930's. Gericke used hydroponics to grow tomatoes, beets, carrots, potatoes, fruits, flowers and more. During World War II, the United States Air Force used hydroponic systems to grow fresh vegetables for troops stationed on small islands in the Pacific.

During 1945-1960, the use of hydroponics expanded rapidly. Countries such as Holland, Spain, France, England, Germany, Sweden, the USSR, and Israel began to experiment with hydroponics. Hydroponics was found to be a suitable farming method for countries with little rainfall and poor soil.

In the 1970's-1980's, new technology such as high-tech plastics and pumps allowed commercial hydroponic systems to be successful.

Today, hydroponic systems are used all over the world. They are used in areas with unsuitable soil such as Mexico, Middle East, and parts of Thailand. Almost any plant can be grown using hydroponics.

SUGGESTED ACTIVITY: COMPARING TRADITIONAL AND HYDROPONIC FARMING

This activity compares traditional farming to hydroponic farming. The teams will be divided into three groups. The first group will be responsible for monitoring the growth of plants in the soil using traditional farming, shown in Figure 5. The second group will be responsible for growing plants hydroponically, shown in Figure 6. The third group will begin with hydroponic vegetables and then remove the plants just after the seedling stage to replant into the soil. When the plants are ready to be harvested, the students will compare the final plants on similar criteria to the observation journal. This will allow the students to identify similarities and differences between traditional and hydroponic farming as well as noting the advantages and disadvantages of each.



Figure 5: Traditional Farming (Left)

Figure 6: Hydroponic Farming (Right)

Source: <http://www.vegetable-garden-guide.com/images/lettuce-little-gem2a.jpg>

Source: http://www.umassvegetable.org/images/soils_crops_pest_mgt/disease/lettuce_septoria_blight.jpg

MAINTAINING A HYDROPONIC SYSTEM

PEST AND DISEASE CONTROL

Pests can be one of the most damaging problems in a hydroponic system. Pests can include insects, birds, or other animals. The hydroponic system is a very good place for these pests to live because it provides a protected area that has lots of food. Mosquito netting is put around the system to prevent the pests from getting in; however, some pests may still get into the system. The best way to keep pests away is by looking for them. Every day the entire system should be inspected for any insects, caterpillars, slugs, and snails. They like to hide in corners and on the bottoms of leaves. If pests are found it is very important to remove them from the system. Removing them will interrupt their natural life cycle and create an undesirable environment for the pests to live in. Aphids, common pests in Thailand can be seen in Figure 7.



Figure 7: Leaf infested with Aphids

Source <http://pikul.lib.ku.ac.th/>

Disease, shown in Figure 8 can be a major problem in hydroponic systems. Because all the plants share the same water, the disease can spread very quickly and infect the other plants. Good cleaning practices, explained below, will reduce the risk of disease.



Figure 8: Lettuce affected by Blight

Source http://www.umassvegetable.org/images/soils_crops_pest_mgt/disease/lettuce_septoria_blight.jpg

Not all insects are pests. There are some insects that do not feed on the plants but on other insects instead. These insects are beneficial because they will eat other pests' eggs and help keep the hydroponic system healthy. These bugs include dragonflies, wasps, ladybugs, and praying mantises. These insects do not need to be removed and will not damage the plants. Pesticides should not be used because they are harmful for people's health and it reduces the value of the plants.

CLEANING THE SYSTEM

After each crop is harvested, the system should be cleaned in order to keep the next crop of plants healthy. Starting with a clean system will help prevent disease and algae from being a problem. When no plants are being grown in the system, a mixture of bleach and water can be used to clean and disinfect the system. Gentle scrubbing can remove any build up of algae or other material from the plastic sheeting in the hydroponic bed. After using any cleaning materials the system should be thoroughly rinsed and allowed to dry before new plants are to be grown. The pump's filter and all pipes should be regularly checked to make sure there are no clogs.

CHECK PH AND NUTRIENT CONCENTRATION LEVELS

Measuring the pH will show how acidic or basic a solution is. The pH scale goes from 1 to 14. A pH of 1 is the most acidic and a pH of 14 is the most basic. A pH of seven is neither acidic nor basic and is called neutral. Plants can only grow if they are in an environment with a favorable pH level. This makes it very important for the pH levels of a hydroponic system to be closely monitored. pH can be measured using pH test strips, as shown in Figure 9, or an electric pH meter. A standard pH level to keep the nutrient solution in the hydroponic system is between 5.5 and 6.

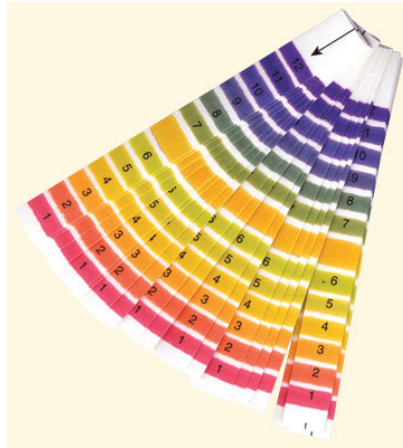

Figure 9: pH Test Strips

Source: <http://www.brupaks.com/images/products/PH-STRIPS.jpg>

The concentration of nutrients in the water must be maintained in the hydroponic system. This can be measured using an electrical conductivity meter. An electrical conductivity meter measures the amount of impurities in water. This can measure the amount of nutrients in measurements of electrical conductance per centimeter or mmho/cm. The directions on the fertilizer packet will recommend an electrical conductance level for the nutrient solution. If the concentration is lower than this, then more nutrients must be added and if the concentration is higher more water must be added. Throughout the growth of the plants, the concentration must be checked and corrected regularly.

LIGHT CONTROL

The nutrient solution is an ideal mixture to grow plant life in. This is beneficial for the plants you are growing. It also is a perfect place for algae to grow, as seen in Figure 10. If it grows enough it can clog pipes and stop water-flow through the channels. Algae require nutrient to grow, so as it grows it will absorb the nutrients that are supposed to be for the plants in the system. Algae require light to grow. Therefore if light is kept out of the nutrient solution it will decrease the chance of algae growth. While the system is in operation, as much light as possible should be blocked from the solution. Foam boards should cover the entire surface of the solution and the tank must be kept closed.



Figure 10: Algae in the Hydroponic System

Source: Kid-Arn (2008)

SUGGESTED ACTIVITY: CLEANING THE HYDROPONIC SYSTEM

This activity involves the students cleaning the hydroponic system together as a class. This will be done after the vegetables have been harvested. The students will gently scrub the channels and remove any build up of algae or other material. This will give the students more hands-on experience working with the system and they will learn this portion of the maintenance if needed in the future.

SUGGESTED ACTIVITY: SMALL-SCALE HYDROPONIC SYSTEM

Another activity we developed is a project involving a do-it-yourself hydroponic system at home. The students will create a small-scale hydroponic system at their houses or in the classroom. The project would have to start early in the semester to allow for time to grow the plants. The activity would involve:

- Start a seedling bed as described in operation manual
- Cut in two pieces $\frac{1}{2}$ to $\frac{1}{3}$ from the top of the soda bottle
- Drill $\frac{1}{4}$ inch hole in the cap
- Cut a 1 by 10 inch strip from a cotton shirt
- Invert the top section and put it in the bottom of the soda bottle as shown below in Figure 11.

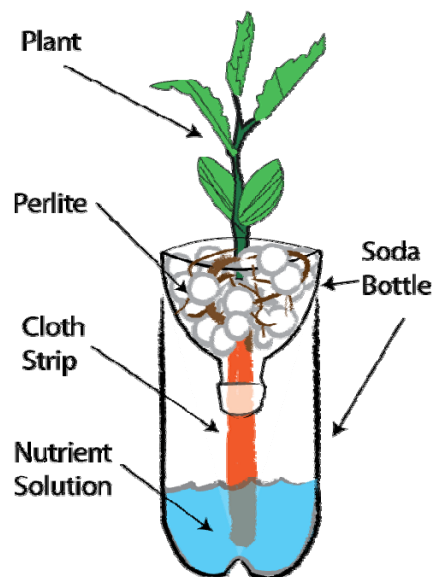

Figure 11: Inverted Soda Bottle

Place the shirt piece through the cap and into the inverted top to make it a wick for that water
Fill the inside of the top half with perlite or another hydroponic medium
Once the seed has matured in a seedling bed place it in the perlite or another hydroponic medium

The students can then use their knowledge of hydroponics to care for the plant and present it to the class at the end of the semester.

EXPECTED LEARNING OUTCOMES

PLANT BIOLOGY

Students should know the basics of plant biology. They should understand the stages of plant life, parts of the plant and their functions, and the role of nutrients in plant growth.

Activity: Plant Development Journal

Students will analyze and see all the stages of plant life. They will monitor a plant and keep detailed records of its growth. Students will also participate in maintaining the system by checking for pests.

Science and History of Hydroponics

Students will understand how hydroponics works. They will see firsthand and understand how the dynamic root floating technique (DRFT) works. The students will learn about the basic parts of a hydroponic system and its functions. The students will learn the advantages and disadvantages of hydroponics. They will also learn about the history of hydroponics.

Activity: Comparing Traditional and Hydroponic Farming

The students will compare the similarities and differences between traditional and hydroponic farming. In addition, they will evaluate the advantages and disadvantages of each farming method.

Maintaining the Hydroponic System

Activity: Cleaning the Hydroponic System

Students will understand how to maintain a DRFT hydroponic system. They will learn about pests and understand that not all insects are pests. Students will be taught how to clean a hydroponic system. They will understand that algae are pests and will grow if there is light in the nutrient solution. Students will also check the pH of the nutrient solution and will learn how to adjust it. If an electrical conductivity (EC) meter is available, they will learn how to check the concentration of nutrients in the water and how to maintain it.

Activity: Small-Scale Hydroponic System

Students will create their own small hydroponic system at home or in the classroom. This activity is meant to include all the topics listed above. In addition, if done at home it promotes the use of hydroponics outside the classroom.

Addition information can be found at <http://www.hydroponicsonline.com/lessons/table-of-contents.htm>

SOURCES

Bradley, P., & Marulanda, C. (2000a). Building by design: Hydroponics in developing countries, part 1. *The Growing Edge*, 11

Marulanda, C., & Izquierdo, J. (1993). *Technical manual: Popular hydroponic gardens: Audiovisual course*. Santiago: FAO Regional Office for Latin America and the Caribbean.

Hydroponics Online. (2006). *Hydroponics Online School*.
<http://www.hydroponicsonline.com/lessons/table-of-contents.htm>

National Gardening Association. (2009). *Floating Gardens in Soda Bottles*.
<http://www.kidsgardening.com/hydroponicsguide/hydro7-3.asp>

Operation Manual for the MSU Demonstration School Teacher



Aubrey Ortiz, Hilary Rotatori, Liz Schreiber, George von Roth
Worcester Polytechnic Institute

Created February 2009

TABLE OF CONTENTS

List of Figures.....	ii
Operation Manual.....	1
Structural Maintenance and Assembly.....	1
Styrofoam Boards.....	5
Nutrient Solution.....	5
Growing and Germinating Seeds in Sponges.....	7
Pest Control and Disease.....	9
Temperature Control.....	10
Pump and Water Levels.....	10
Harvesting.....	11
Cleaning.....	11
Daily Maintenance Tasks.....	11

LIST OF FIGURES

Figure 1: Parts of the Hydroponic Frame	1
Figure 2: Hydroponic Frame with Plywood and Foam Ridges	2
Figure 3: Black Polyethylene Sheet Covering the Channels	3
Figure 4: Clear Polyethylene Sheet and Mosquito Netting	4
Figure 5: Styrofoam Board	5
Figure 6: Liquid Fertilizers	5
Figure 7: Premixed Solid Fertilizer Salts	6
Figure 8: pH Test Strips	6
Figure 9: Sponge with Cuts.....	7
Figure 10: Seedling Tray	7
Figure 11: Seedling Tray with Sponge and Nutrient Solution.....	8
Figure 12: Seedling Ready to be transplanted	8
Figure 13: Seedlings Transplanted into Styrofoam Board.....	9
Figure 14: Leaf Infested with Aphids Source: http://pikul.lib.ku.ac.th	9
Figure 15: Algae in the Hydroponic System.....	10
Figure 16: Lettuce Affected with Blight.....	10
Figure 17: Adjustable Drainage Pipe	11

OPERATION MANUAL

STRUCTURAL MAINTENANCE AND ASSEMBLY

This hydroponic system was designed to be easily taken apart and moved. Diagrams of the different parts of the hydroponic system are shown in Figure 1. There are two outer roof frames (red) and two inner roof frames (green). These are connected together using supporting beams and cross braces (blue). Nuts and bolts attach all the pieces to each other. All the bars and parts should be labeled with numbers because the drill holes for the bars are not the same. Bury the concrete feet into the ground to keep the hydroponic system level and stable.

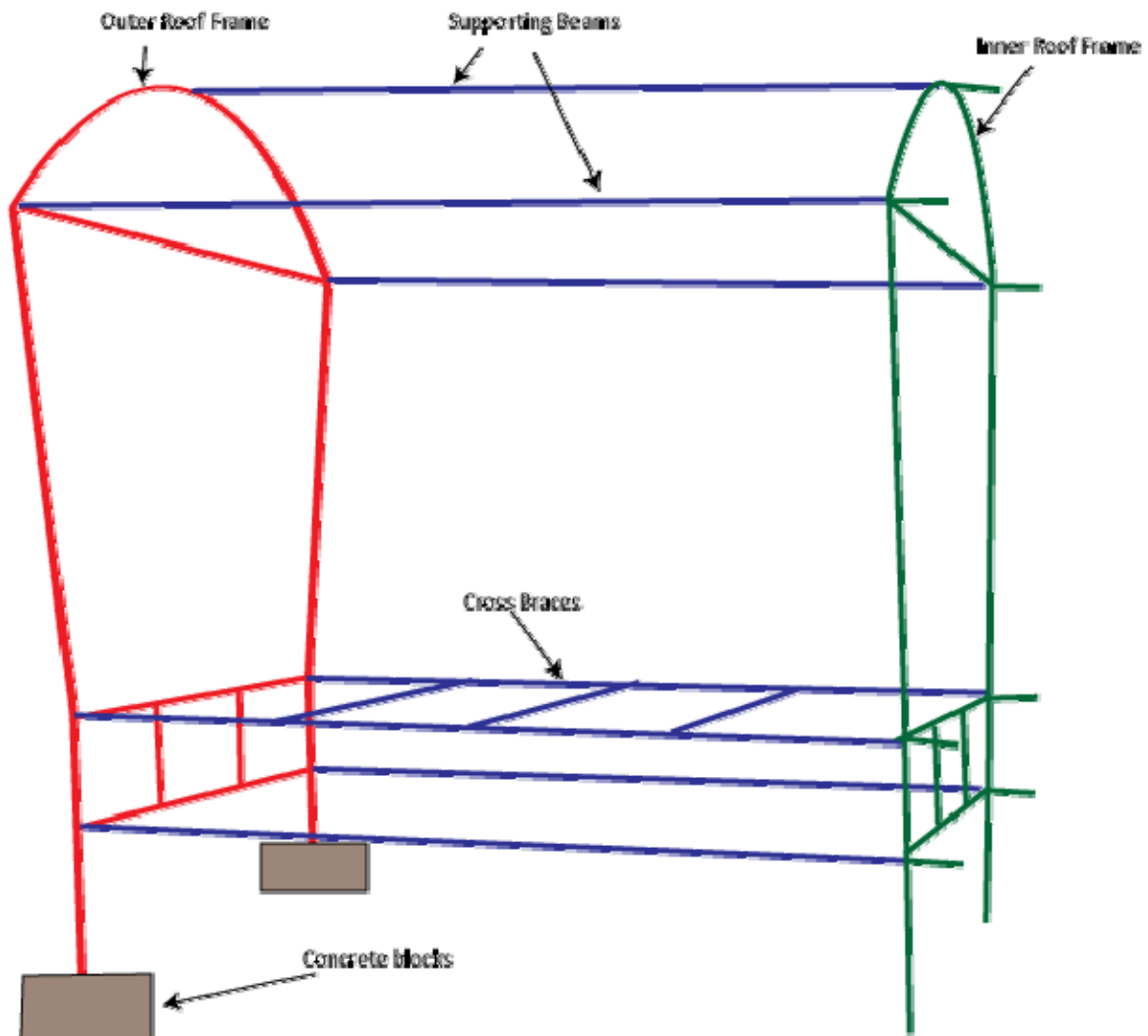

Figure 1: Parts of the Hydroponic Frame

The plywood is attached to the frame using nuts and bolts and can easily be removed or assembled, this can be seen in Figure 2. The “ridges” on the channels are made of cut Styrofoam and should be firmly glued to the plywood. The ridges should be aligned to each other and spaced 8.5 cm away from each other from top to top.

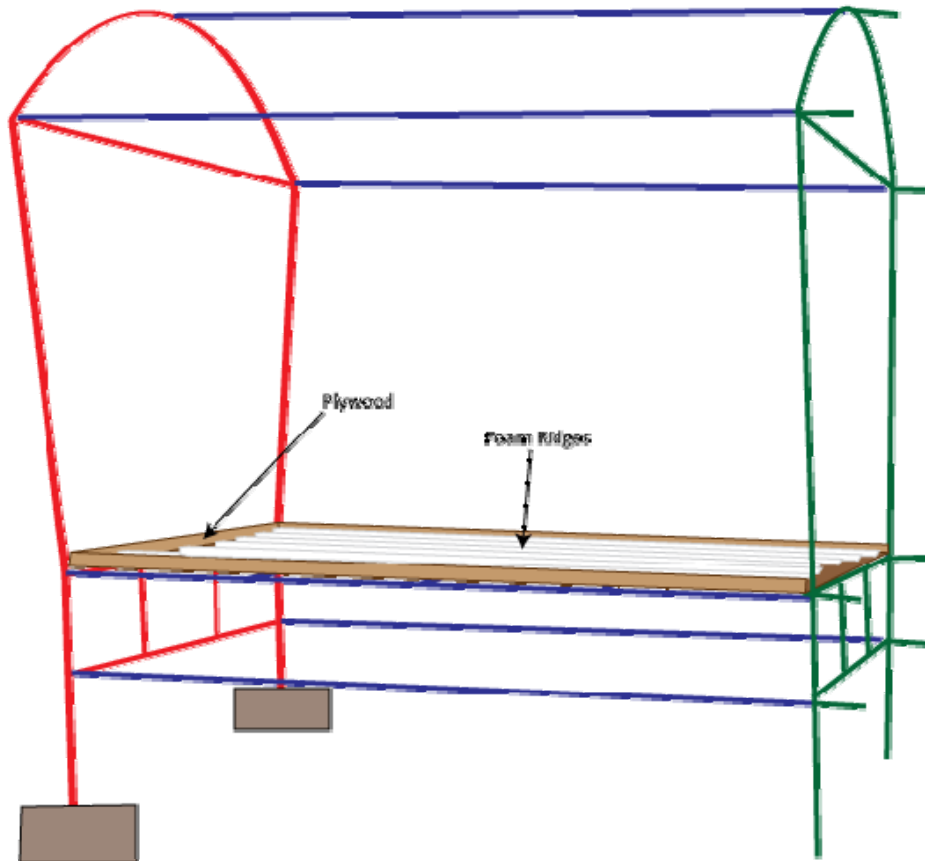

Figure 2: Hydroponic Frame with Plywood and Foam Ridges

Black plastic sheeting shown in Figure 3 covers the plywood and foam and is secured to the frame using clips. Make sure the black plastic sheeting contours the “ridges” in order to make the channels.

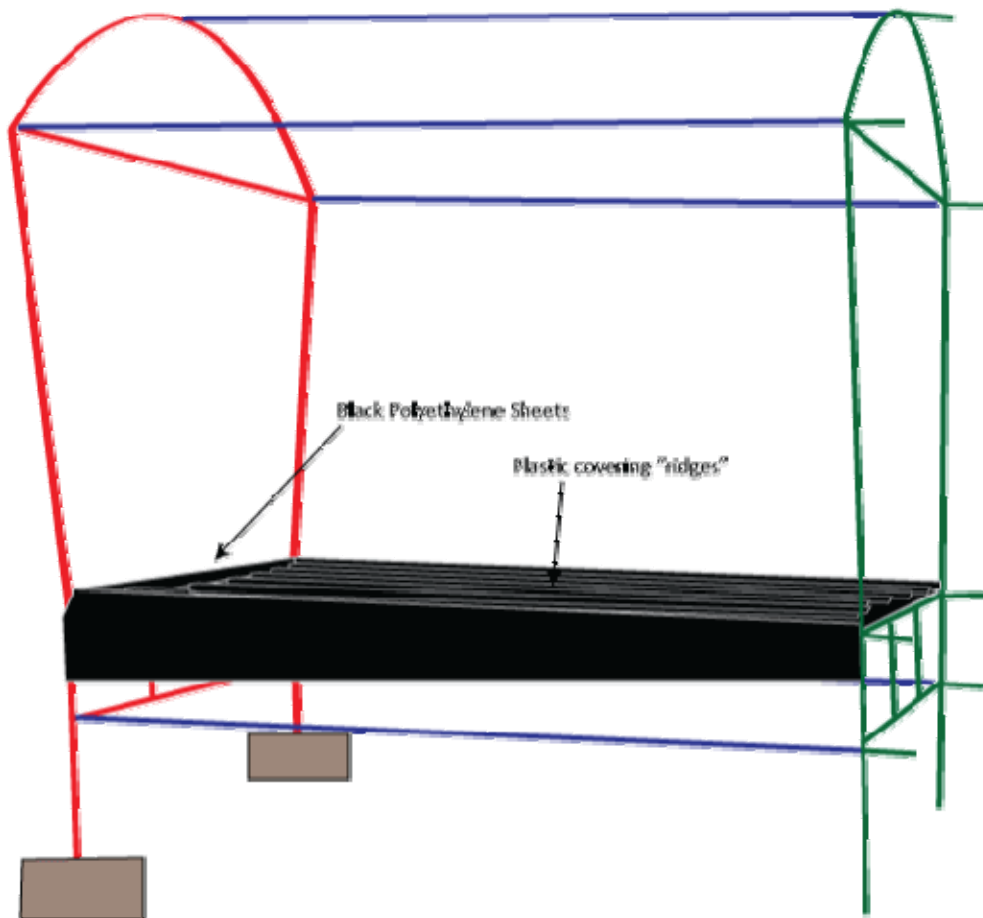

Figure 3: Black Polyethylene Sheet Covering the Channels

The transparent plastic sheet goes over the top of the system and is held tight by metal clips. The sheeting protects the system from weather conditions. Insect netting is attached around the sides using metal clips to prevent pests from getting into the system as shown in Figure 4.

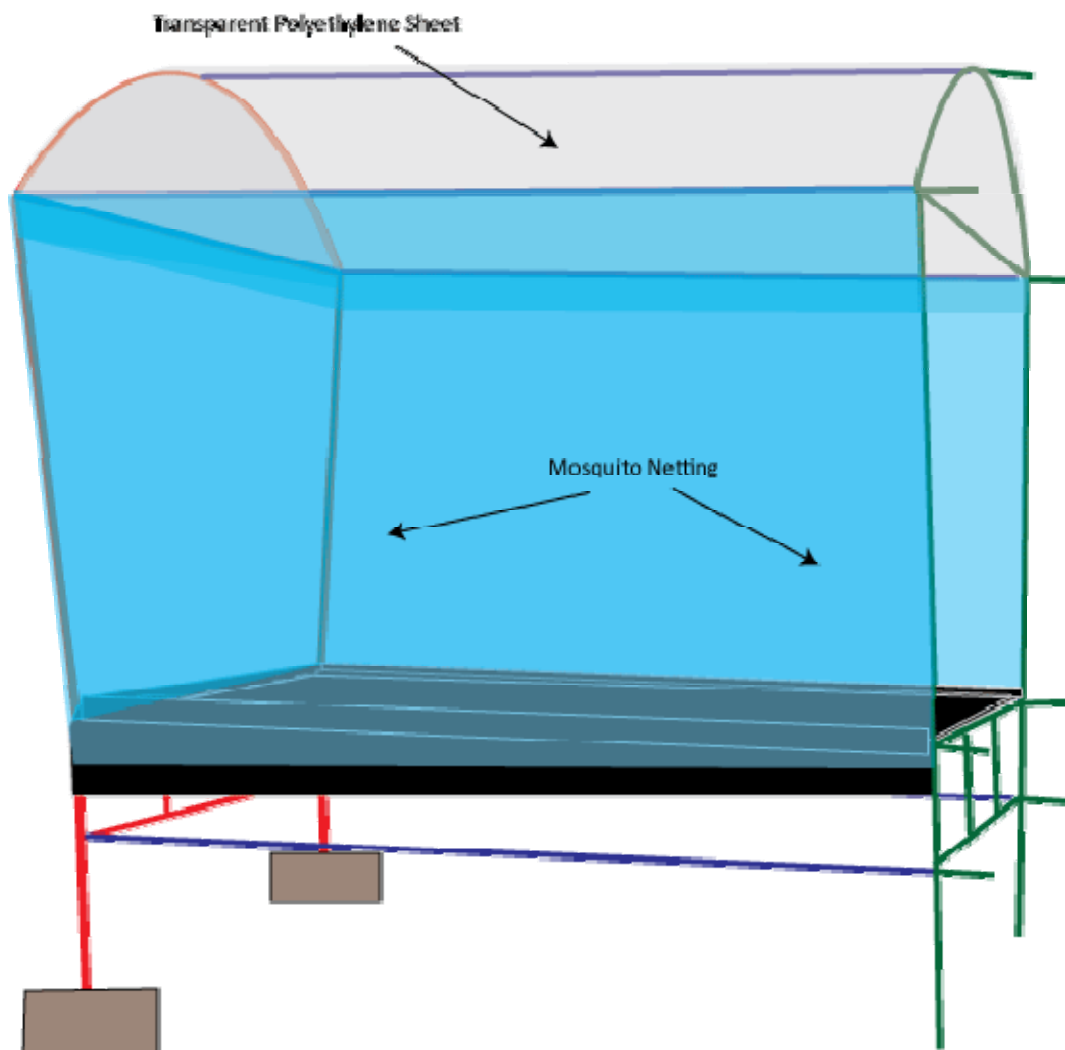

Figure 4: Clear Polyethylene Sheet and Mosquito Netting

When the water temperature is above 30°C, the green plastic netting should be placed over the roof to block out some sunlight and lower the temperature. This is also held in place with the metal clips.

Position the tank of the system underneath the drain of the hydroponic bed. The drain is connected directly to the tank with the flexible hosing. The pump is placed into the tank and is connected to the PVC tubing that goes underneath the system to the other end and pours water into the channels.

The metal frame should always be adequately painted to keep it from rusting.

STYROFOAM BOARDS

Styrofoam boards floating above the hydroponic channels will support the plants. Dimensions of the Styrofoam boards are shown in Figure 5. Two pieces of Styrofoam boards, one 120cm by 70cm, and another 30cm by 70cm span the width of the bed and 2.5 cm holes are cut to the specifications below. There are 17 holes across and 5 holes down the length of each board. Approximately 9 boards will be used to cover the entire hydroponic bed. The holes should line up exactly with the “ridges”

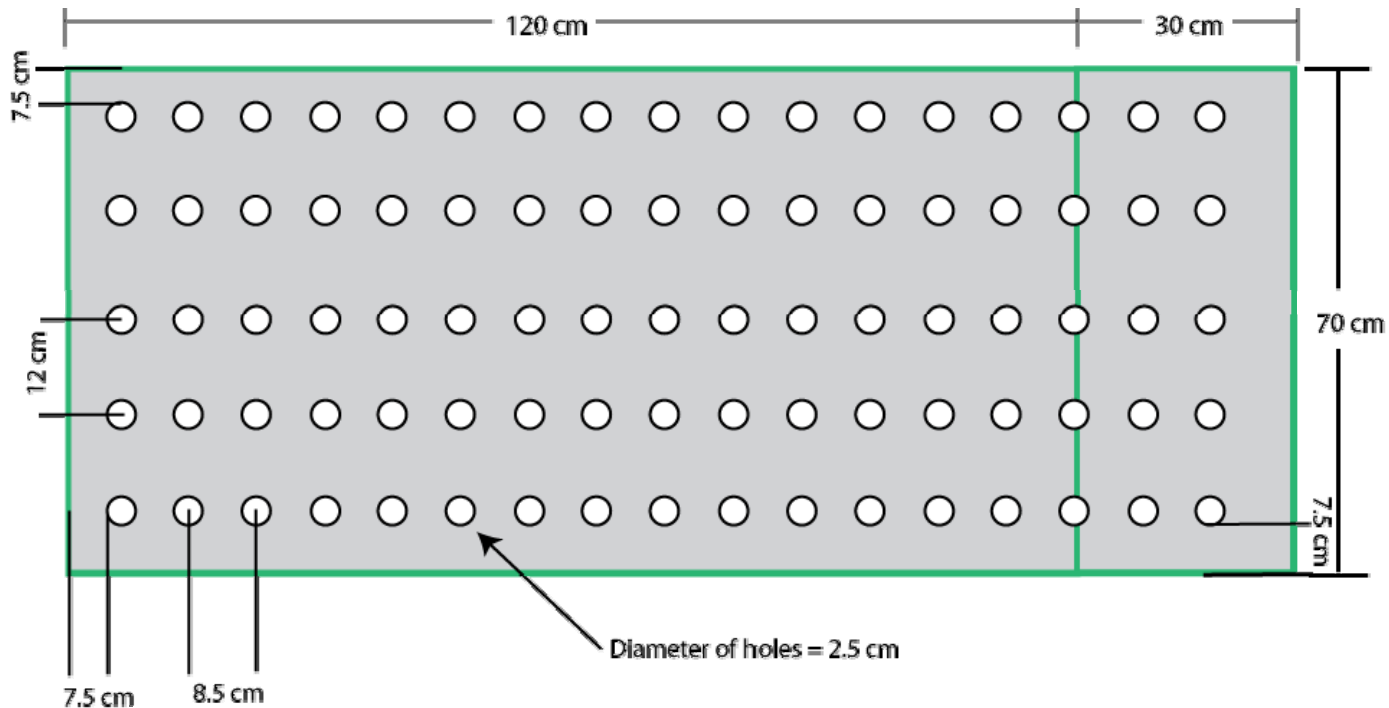

Figure 5: Styrofoam Board

NUTRIENT SOLUTION

It is recommended to buy and use hydroponic fertilizer specially formulated for the crops you are growing. If you are growing kale or lettuce, buy fertilizer for leafy vegetables. If you are growing tomatoes or cucumber, buy fertilizer for fruity vegetables. Either liquid fertilizer or premixed solid fertilizer salts can be used. Liquid fertilizers are more expensive but easier to mix. Liquid fertilizers usually come in two bottles shown below in Figure 6.



Figure 6: Liquid Fertilizers

Source: http://en.bangsalagro.com/images/product_nutrient_solution_7.jpg

Solid fertilizers are less expensive and harder to mix, but also give you more control. Solid fertilizer salts usually come premixed, typically in 2-3 packages shown in Figure 7. You can

also buy the individual nutrients in many small packages. If your plants have a nutrient deficiency, it is easy to fix just by adding the correct solid fertilizer.



Figure 7: Premixed Solid Fertilizer Salts

Source: http://en.bangsalagro.com/images/product_nutrient_solution_7.jpg

Follow the mixing procedure on the package of your fertilizer. A general rule is that fertilizers should be diluted in water before they are mixed together. If you mix them in high concentrations, they can chemically react and become ineffective.

Test the pH of the nutrient solution every 1-2 days using pH meters or pH test strips (litmus), like the ones seen in Figure 8. The pH should always be kept between **5.5 – 6**. pH buffers can be used to change the solution's pH level.



Figure 8: pH Test Strips

Source: <http://www.brupaks.com/images/products/PH-STRIPS.jpg>

Buying an electrical conductivity (EC) meter is recommended but not required. EC meters check the level of nutrients in the water. If you have an EC meter check the water every 2 days. Find the recommended levels for nutrient concentration in (mmho/cm) from the directions of your fertilizer. If the concentration is lower than the recommended level then more nutrients must be added. If the concentration is higher than the recommended level then more water must be added

When the drainage is at the high setting of 7 cm, the hydroponic system can hold 450L. When the drainage is at the low setting of 3 cm, the hydroponic system can hold 92L. The water tank must always have extra solution and it should be constantly circulating water.

GROWING AND GERMINATING SEEDS IN SPONGES

The sponge should be cut into squares (3.5 cm by 3.5cm) to fit into the holes (2.5cm diameter) of the Styrofoam board. The pieces of square sponges should be slit all the way through to allow the seed to fit inside and for the roots to grow out the bottom. A diagram of the sponges is shown in Figure 9.

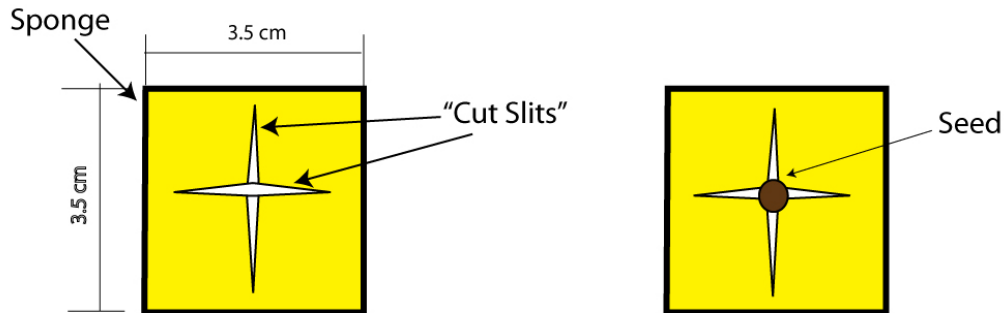

Figure 9: Sponge with Cuts

Insert seeds into the sponge. The sponge squares should be put in the seedling tray shown in Figure 10.



Figure 10: Seedling Tray

Put the cut sponge squares into the seedling tray and add nutrient solution as shown in Figure 11.

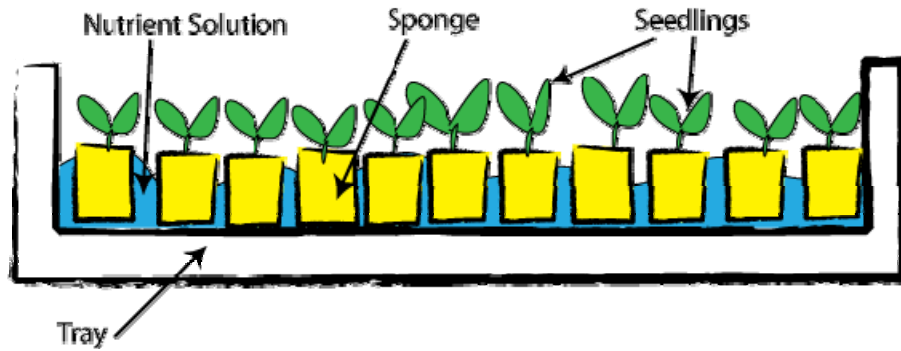

Figure 11: Seedling Tray with Sponge and Nutrient Solution

The seedlings are ready to be moved into the hydroponic system when their roots are 3-5 cm long or when the primary leaf is well developed shown in Figure 12.

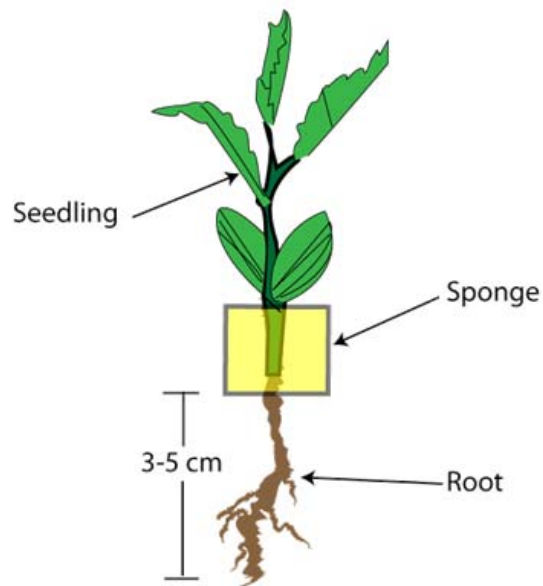

Figure 12: Seedling Ready to be transplanted

Put the seedlings and sponges securely into the Styrofoam board as shown in Figure 13. One board can hold 85 plants.

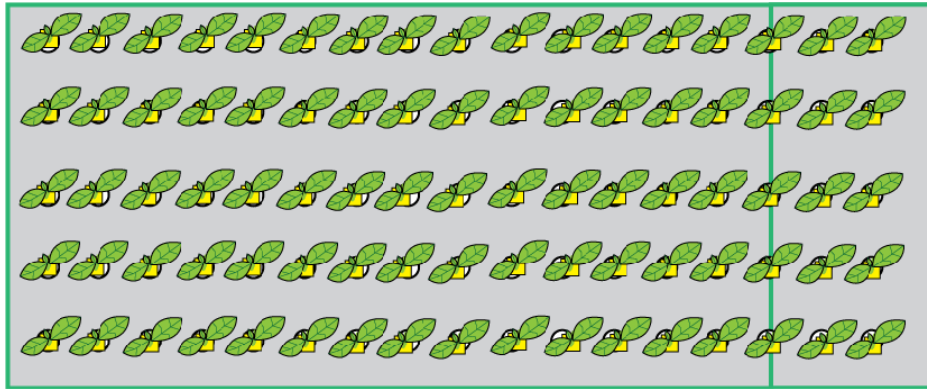

Figure 13: Seedlings Transplanted into Styrofoam Board

PEST CONTROL AND DISEASE

The mosquito net should be clamped tightly on the structure to prevent insects from getting inside. The plants should be thoroughly inspected every day for pests. Insects like to hide in the corners or behind leaves. Any pests found should be picked off by hand immediately. Aphids, shown in Figure 14, are a common pest found in Thailand and should be removed immediately. Pesticide is not recommended because it is not healthy to eat and reduces the value of the vegetables.



Figure 14: Leaf Infested with Aphids

Source: <http://pikul.lib.ku.ac.th>

Algae, shown in Figure 15, will grow if there is light shining into the solution. Any gaps or spaces that allow light into the solution should be blocked off completely. The Styrofoam boards should fit tightly on the channels and block out any sunlight. Gaps or spaces can be sealed with tape to block out light.



Figure 15: Algae in the Hydroponic System
Source: Kid-Arn (2008)

If any plants show signs of disease, like in Figure 16, remove the plants immediately to stop the disease from spreading to the other plants. Disease can spread quickly because all the plants share the same water.



Figure 16: Lettuce Affected with Blight
Source http://www.umassvegetable.org/images/soils_crops_pest_mgt/disease/lettuce_septoria_blight.jpg

TEMPERATURE CONTROL

Try to keep the temperature of the system below 35°C. When the temperature of the water is above 30°C, cover the roof of the system with temperature reducing material to reduce sunlight. When the water temperature is below 27°C, remove the material to give the plants more sunlight.

PUMP AND WATER LEVELS

Keep the pump submerged under water when it is turned on. The air hose end must be above the water so it can take in air. Continuously run the pump to circulate the water and keep it oxygenated. The filter must be in place so the pump does not get clogged. Check the pump for clogs everyday so that it always running.

The water level can be adjusted to a height of 3 cm or 7 cm with the adjustable drainage pipe shown in Figure 17. When the plants are still small and young, keep the height of the water at 7 cm.

Once the plants become older and their roots reach the bottom, adjust the water height to 3 cm by twisting the upper pipe. This will give the plants more air to receive oxygen.

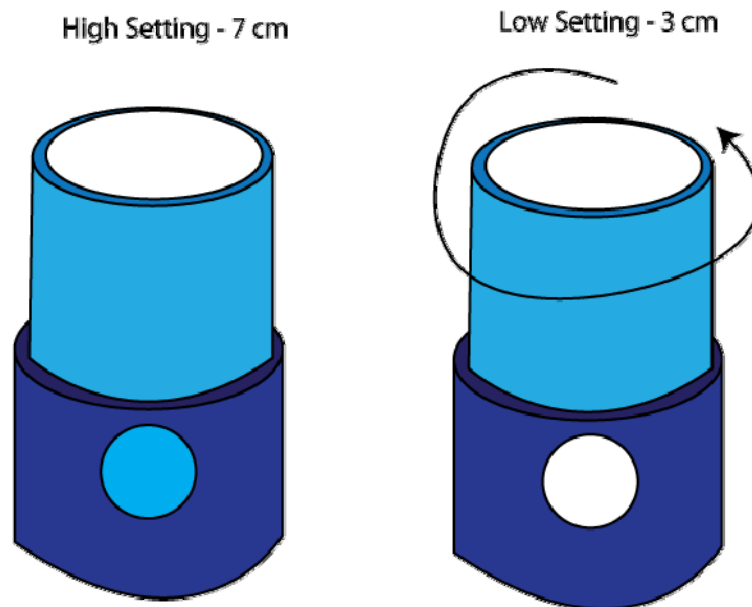

Figure 17: Adjustable Drainage Pipe

HARVESTING

The harvest times vary depending on the kind of vegetable grown. However, hydroponic plants grow much quicker than traditional farming and more crops can be grown per year.

CLEANING

After every crop the system should be cleaned to prevent disease and algae. Use a mixture of bleach and water to clean the system. Gentle scrubbing can remove any buildup of algae or plant roots. Be gentle so you do not rip the plastic sheeting. After cleaning, the system should be thoroughly rinsed and dried before any new plants are grown.

DAILY MAINTENANCE TASKS

- Make sure the pump is working correctly. Ensure there is enough water in the tank and it is circulating water. Check the pump for any clogs and remove any debris from the filter. The air hose end must be above the water to receive air.
- Inspect all the plants for pests. Any pests found should be picked off by hand immediately.
- Inspect all the plants for disease. If found, remove any diseased plant immediately to stop the disease from spreading.
- Check the pH every 1 – 2 days. The pH should always be kept between **5.5 – 6**. Use pH buffers to adjust the pH level.

- If you have an EC meter, check the concentration levels of the nutrient solution every 2 days. Follow the directions of your fertilizer for the recommended concentration level. If the concentration is lower, then more nutrients must be added. If the concentration is higher, then more water must be added.
- When the temperature of the water is above 30°C, cover the roof of the system with temperature reducing netting to reduce sunlight. When the water temperature is below 27°C, remove the temperature reducing netting to give the plants more sunlight.

Business Activities for the MSU SIFE Team



Aubrey Ortiz, Hilary Rotatori, Liz Schreiber, George von Roth
Worcester Polytechnic Institute

Created February 2009

BUSINESS ACTIVITIES FOR THE MSU SIFE TEAM

HYDROPONICS VEGETABLE BUSINESS FAIR

This activity involves small groups of students creating their own businesses and selling vegetables at a business fair. This fair would be at the school and teachers, parents, and other community members would be invited to attend and buy the hydroponic vegetables.

- Separate the students into groups
- Each group has their own section of the hydroponic unit
- SIFE team will organize a fair at the after harvesting the vegetables
- The students will have to advertise for this event, in community, school, university (target professors)
- At the fair the students will have a stand where they can sell their vegetables
- They will make posters that will promote hydroponics, give the benefits of it in terms of health and environmental anything that will help them sell their produce
- They can make a business name and slogan song
- They can set prices for their vegetables or barter
- There will be a competition at this event monitored by the SIFE students
- They SIFE students will judge each group of students based on who well they achieve certain criteria.
 - Creativity of posters and stands
 - How well they promoted hydroponics and its benefits
 - How well they “performed” in the business with selling and prices
- The groups will be scored and ranked and winners will get prizes (donated by SIFE?)
- Posters could stay around the school to promote hydroponics

This activity would teach the students about entrepreneurship by giving them their own businesses to manage. The activity would introduce marketing and advertisement techniques since the students are competing against other companies. The students would also learn about finance by pricing their vegetables high enough to make a profit, but low enough to be within the competitors’ prices. Lastly, the students would understand the benefits of growing hydroponic vegetables while creating posters and advertisements. This activity, on a larger scale, is beneficial to the development and promotion of the use of hydroponic vegetables because the fair is open to the teachers, parents, and community members who would learn about these benefits by either seeing the advertisements or attending the fair.

HYDROPONIC VEGETABLE STOCK MARKET

This is an activity that introduces the students to the principles and concepts of the stock market.

- Each student will have the same amount of fake money which they can use to buy shares of the two different vegetables being grown
- The vegetables can have the same stock price in the beginning, but based on how well they do in the hydroponic system the price can go up or down
- The SIFE team will have to monitor the growth of the plants and adjust the stock price depending on how the plants are growing
- The students will be able to buy or sell their stocks once or twice a week
- In the end the students will sell all their stock and see how much profit they, if any, made
- The students will be ranked and the ones who make the most profit will win a prize

This activity exposes the students to the stock market, which is an important part of national and international business economics. They would be directly involved in the buying and selling of their stocks and managing their money, teaching them about finance. This hands-on style of learning reinforces the ideas and principles of the stock market.

OWNER AND VENDOR ROLE PLAYING

This activity is a role playing game where half of the students are owners of a hydroponic system and the other half are vendors selling vegetables and they have to work together to buy and sell vegetables.

- Split the class into 2 groups
- One will be owners and one vendors
- The owners and vendors will be given profiles including how much money they have to spend on these system
- The owners will have to pay a certain amount of money (all the same) to construct and maintenance their system
- The owners will have to find a vendor that will be willing to buy his plants to sell
- They will have to decide on a price or find someone else to partner with
- The seller will then randomly be told how money they were able to make from selling the vegetables
- Whoever has the most money in the end will be the winner and a prize can be rewarded

Each activity is intended to be fun and engaging in order to spark the interest of the students, causing them to want to participate more. This would indirectly teach the students about entrepreneurship and environmental sustainability.