

# Expanding the Outreach of the Cape Town Museum of Childhood through Mobile Exhibits

By

Trevor Faber

Grace McCarthy

Patrick McKenna

Grace Solod



# Expanding the Outreach of the Cape Town Museum of Childhood through Mobile Exhibits

An Interactive Qualifying Project Report  
Submitted to the Faculty of  
WORCESTER POLYTECHNIC INSTITUTE  
in partial fulfillment of the requirements for the  
Degree of Bachelor of Science

By  
Trevor Faber  
Grace McCarthy  
Patrick McKenna  
Grace Solod

Date  
14 December 2022

Report Submitted to:

Sarah Atmore,  
Cape Town Museum of Childhood

Professors Gbetonmasse Somasse and Thidinalei Tshiguvho,  
Worcester Polytechnic Institute



## ABSTRACT

Due to economic and geographic barriers in Cape Town, only a limited population can benefit from the educational experiences offered by the Museum of Childhood. We collaborated with the museum to develop a mobile exhibit which will share their message of celebrating childhood with communities outside their reach. Utilizing results from surveys and interviews, we developed an exhibit message, designed immersive storytelling booths, and created a virtual tour, which would allow the museum's overall message to reach a larger audience.



## ACKNOWLEDGEMENTS

We would like to thank our sponsor, Sarah Atmore, and the Museum of Childhood for guidance as well as their patience, hospitality, and support. We would also like to thank the staff of Centre for Early Childhood Development for meeting with us, giving insight, and providing a welcoming work environment. We would like to thank our advisors, Gbetonmasse Somasse and Thidinalei Tshiguvho for meeting with us and providing feedback. We would like to thank Professor Ingrid Shockey for her guidance through ID2050. With her help, we developed the basic skills needed to complete this project and were able to flourish as a team. Finally, we would like to thank anyone who took the time to fill out a survey or speak with us during an interview. Your thoughts were crucial to the completion of this project.



*Project Team (from left to right): Sarah Atmore, Patrick McKenna, Grace Solod, Bomikazi Nomzanga, Grace McCarthy, Trevor Faber, Navarne Weeder, and Eric Atmore.*

## EXECUTIVE SUMMARY

### A MUSEUM TO CELEBRATE CHILDHOOD IN A DIVERSE CITY

Established in 1852, Cape Town is known for its vibrant arts, culture, and community that enriches the lives of its residents. One of the many cultural opportunities available to them is the Cape Town Museum of Childhood, which is dedicated to the exploration and celebration of childhood. The museum focuses on educating its visitors about the importance of supporting and celebrating childhood, children’s rights, and the safety of children. The space itself is designed for people of all ages to explore their creativity and learn about the importance of childhood in a fun and engaging way.

Easy access to the exhibits is limited to more affluent residents living near the museum. The city of Cape Town experiences significant economic and geographic disparities which isolate less privileged populations and limit their access to certain resources like the Museum of Childhood. The Cape Town Museum of Childhood looks to address this reality by providing opportunities for engagement with the museum’s programs.

### EXPANDING THE MUSEUM’S OUTREACH THROUGH A MOBILE EXHIBIT

The goal of this project was to collaborate with the Museum of Childhood in developing a mobile exhibit platform to share the museum’s message of celebrating childhood with communities outside their reach. We achieved this goal by addressing the following objectives:

1. Assess the community’s interest in a mobile exhibit platform
2. Identify the potential message of the mobile exhibit
3. Design a mobile exhibit prototype with the potential to provide new learning opportunities for community members across the city of Cape Town

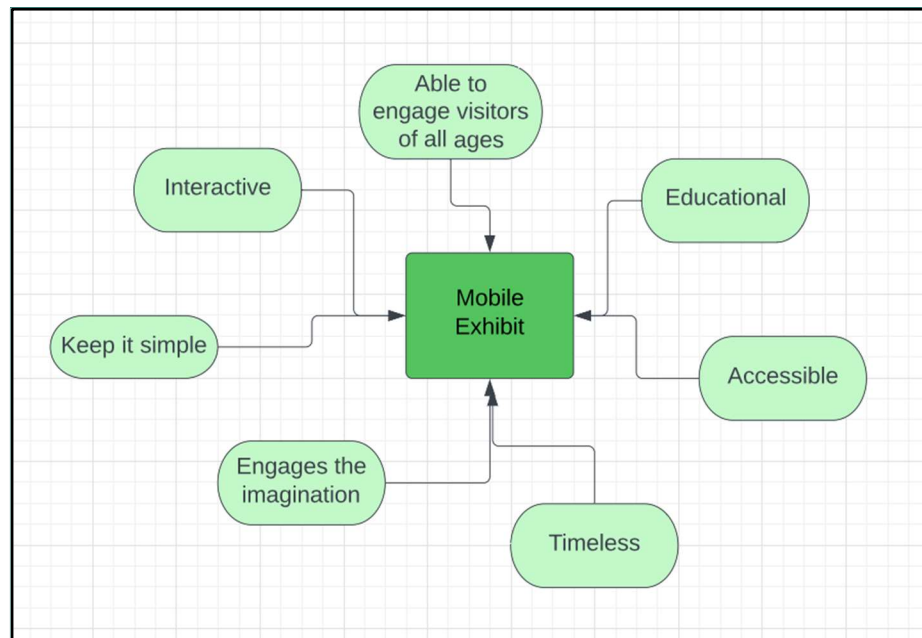
To achieve these objectives, we gathered survey responses from museum visitors to identify what was currently working and which exhibits were more favorable than others. We interviewed representatives from the Parent Centre (who work directly with parents in townships and other low-income communities), libraries, and schools to gather perspectives from the target audience. These interviews, as well as interviews with staff from the Museum of Childhood (MOC) and the Center for Early Childhood Development (CECD), helped to identify potential messages for the mobile exhibit. We analyzed the collected data and perspectives from all stakeholders and used it to inform the themes and message of the exhibit, as well as to design the template. This tool helped us develop the ideas and blueprint for a final product.

### FINDINGS

Overall, the surveys showed that the most common favorite rooms in the museum were the three most interactive exhibits, which were the “100 Years of Toys” room, the “Arts and Crafts” room and the “Story Room”. Surveys also showed that people spent the most amount of time in the most interactive rooms with a focus on *storytelling* or *hands-on activities*.

The target audience interviews provided new and useful perspectives on important issues impacting the lives of children in Cape Town and highlighted a few key points. These included addressing the importance of *the relationship between a parent and their child*, and the importance of including an *interactive element* to the exhibit to keep the visitors engaged with the content.

The interviews with staff members from the Museum of Childhood and the CECD covered content ranging from the potential message of the museum to how the mobile exhibit might work, logistically. The idea that *childhood is a lifelong experience*, not limited by age, and the importance *in highlighting diverse experiences* were mentioned repeatedly. Both messages were incorporated into the final deliverable. Our interviews with the Museum and CECD staff did not show any conclusive preferences in terms of physical and logistical aspects of the design, namely, exhibit staffing, ideal visitor engagement time, and how long the exhibit should remain in one location. From the staff interviews, we identified important elements to consider when building a mobile exhibit (*Figure E1*). Given the lack of clear preference for logistical and physical aspects, our approach was to focus on developing the exhibit around the message as opposed to the other way around.



**Figure E1.** Concept Map of Staff Interviews.

Finally, utilizing the designer template used by the Museum of Childhood for past exhibit developments allowed us to expand upon ideas and themes brought up in our findings to develop a central message for the exhibit. The collaborative process culminated in the following final message: *Celebrating diverse childhood stories*. Within this message, we developed the following key learning goals for the exhibit:

1. I want the visitors to learn how to be aware of different childhood experiences.

2. I want the visitors to learn how to be understanding of different childhood experiences.
3. I want the visitors to learn how to be empathetic towards others, especially children.

After developing the message and learning goals, we were able to develop the two main deliverables outlined below: A guide to developing immersive storytelling booths and a virtual tour of the museum.

#### IMMERSIVE STORYTELLING BOOTHS

Based on the described findings, we created a detailed plan for the implementation of a mobile exhibit for the museum, contained in *Appendix I*. The exhibit utilizes four total booths. Three main small booths each provide a unique, immersive experience focused on different childhood stories. A fourth booth then acts as an interactive activity in which visitors can incorporate their own stories into the exhibit. The booth design is seen below in *Figure E2*.



**Figure E2.** Proposed Immersive Storytelling Booth CAD Rendering

#### VIRTUAL TOUR

The second deliverable produced was the virtual tour of the museum, linked in *Appendix J*. This tour allows people who do not have the physical or financial means of getting to the museum to experience what the museum has to offer. While not a complete replacement to an in person visit, the virtual tour allows the “visitor” to see each room in three dimensions and explore the layout of the museum. The virtual tour can also be included with the mobile exhibit

via a QR code. The QR codes can be placed on the sides of the booth so anyone visiting the booths will be able to have access to the museum itself. The virtual tour will provide an opportunity for the museum to connect with a larger audience, addressing the bigger picture of the project. A reference image of the virtual tour can be seen in *Figure E3*.

Overall, the goal of this project was to develop a mechanism by which the Museum of Childhood can reach a broader audience to further spread their message and raise awareness on important topics relating to children. By increasing the number of people who understand the importance of childhood and childhood safety, the Museum of Childhood can support the development of a safer and more inclusive childhood experience for young people across the city of Cape Town, and potentially beyond. We were able to design a mobile platform prototype that will benefit the Cape Town Museum of Childhood and increase their outreach.



*Figure E3. Still Image of the Arts and Crafts Exhibit from the Virtual Tour*

## RECOMMENDATIONS

Based on our findings and the status of the deliverable, we recommend that the following actions be taken to contribute towards the development of the mobile exhibit:

1. Secure funding to support the development and construction of the story booths
2. Determine whose childhood stories will be told in each booth
3. Collect the multimedia elements to support each story
4. Contact contractors and graphic designers to carry out the construction and interior design of the booths.

If funding cannot be secured within a reasonable timeframe, it is also possible to create a pilot exhibit which utilizes the overall message and exhibit structure outlined in the exhibit description and construction guide.

To utilize the virtual tour to its full potential, we recommend the software is implemented in the following areas:

1. The museum website
2. The museum's social media platforms (Instagram, Facebook, etc.)
3. Within the mobile exhibit (and future mobile exhibits and outreach programs) using QR codes



## AUTHORSHIP

<b>Chapter</b>	<b>Primary Author</b>	<b>Secondary Author</b>	<b>Primary Editor</b>	<b>Secondary Editor</b>
Abstract	Grace McCarthy	N/A	Grace Solod	Patrick McKenna
Executive Summary	Grace McCarthy	N/A	Grace Solod	Patrick McKenna
Introduction	ALL	ALL	ALL	ALL
Overview of Museum Access and Outreach	ALL	ALL	ALL	ALL
Methodology	ALL	ALL	Grace Solod	Patrick McKenna
Findings and Deliverables	Grace Solod Trevor Faber	Grace McCarthy Patrick McKenna	Grace McCarthy	Grace Solod
Conclusion and Recommendations	Grace Solod Grace McCarthy	Patrick McKenna	Trevor Faber	Grace Solod
Immersive Storytelling Booth Guide	Trevor Faber Grace Solod	Grace McCarthy	ALL	ALL
CAD Designs	Trevor Faber	N/A	N/A	N/A

# TABLE OF CONTENTS

ABSTRACT .....	I
ACKNOWLEDGEMENTS.....	II
EXECUTIVE SUMMARY .....	III
A MUSEUM TO CELEBRATE CHILDHOOD IN A DIVERSE CITY.....	III
EXPANDING THE MUSEUM’S OUTREACH THROUGH A MOBILE EXHIBIT.....	III
FINDINGS.....	III
IMMERSIVE STORYTELLING BOOTHS.....	V
VIRTUAL TOUR .....	V
RECOMMENDATIONS.....	VI
AUTHORSHIP .....	VII
TABLE OF CONTENTS .....	VIII
TABLE OF FIGURES .....	X
TABLE OF TABLES .....	XI
<b>1 INTRODUCTION .....</b>	<b>1</b>
<b>2 OVERVIEW OF MUSEUM ACCESS AND OUTREACH .....</b>	<b>3</b>
2.1 PROMOTING EQUAL OPPORTUNITIES AFTER APARTHEID ERA .....	3
2.2 EXPANDING THE EDUCATIONAL REACH OF THE MUSEUM OF CHILDHOOD.....	4
2.3 EDUCATION OUTSIDE OF THE CLASSROOM.....	5
2.4 CONSIDERATIONS FOR CREATING A MOBILE MUSEUM .....	6
2.5 RELEVANT CASE STUDIES IN MOBILE MUSEUM EDUCATION PILOTS.....	6
2.5.1 <i>Case Study on Impact of Traveling Museum Exhibition on Students from Low-Income Homes</i> .....	6
2.5.2 <i>Family-Friendly Mobile Exhibit for Worcester Historical Museum</i> .....	7
2.6 SUMMARY .....	9
<b>3 METHODOLOGY .....</b>	<b>10</b>
3.1 ASSESS THE COMMUNITY’S INTEREST IN A MOBILE EXHIBIT PLATFORM .....	10
3.2 IDENTIFY THE POTENTIAL MESSAGE OF THE MOBILE EXHIBIT .....	11
3.3 DESIGN A MOBILE EXHIBIT PROTOTYPE .....	11
<b>4 FINDINGS AND DELIVERABLES.....</b>	<b>13</b>
4.1 COMMUNITY’S INTEREST IN A MOBILE EXHIBIT PLATFORM.....	13
4.1.1 <i>Visitors’ Favorite Exhibits</i> .....	13
4.1.2 <i>Additional Visitors’ Experiences</i> .....	15
4.1.3 <i>Fostering Conversations Between Parent and Child</i> .....	17
4.2 MESSAGE OF THE MOBILE EXHIBIT .....	17
4.3 DESIGNING A MOBILE EXHIBIT PROTOTYPE .....	18
4.3.1 <i>Immersive Storytelling Booth</i> .....	19
4.3.2 <i>Expanding Access to the Museum through a Virtual Tour</i> .....	20
<b>5 CONCLUSION AND RECOMMENDATIONS .....</b>	<b>22</b>
KEY FINDINGS AND DELIVERABLES .....	22

LIMITATIONS .....	22
RECOMMENDATIONS ON NEXT STEPS .....	23
<b>6 REFERENCES .....</b>	<b>25</b>
<b>APPENDIX A: PRE-EXISTING MUSEUM FEEDBACK SURVEY (REPRODUCED WITH PERMISSION) .....</b>	<b>27</b>
<b>APPENDIX B: MUSEUM VISITOR HELPFUL FEEDBACK SURVEY .....</b>	<b>28</b>
<b>APPENDIX C: LIST OF INTERVIEWEES .....</b>	<b>29</b>
<b>APPENDIX D: PARENT CENTRE INTERVIEW QUESTIONS.....</b>	<b>30</b>
<b>APPENDIX E: LIBRARIAN INTERVIEW QUESTIONS .....</b>	<b>31</b>
<b>APPENDIX F: SCHOOL PRINCIPAL INTERVIEW QUESTIONS.....</b>	<b>32</b>
<b>APPENDIX G: MUSEUM STAFF INTERVIEW QUESTIONS.....</b>	<b>33</b>
<b>APPENDIX H: DESIGNER TEMPLATE EXAMPLE PAGES (REPRODUCED WITH PERMISSION).....</b>	<b>34</b>
<b>APPENDIX I: IMMERSIVE STORYTELLING BOOTH GUIDE .....</b>	<b>35</b>
INTRODUCTION.....	36
MESSAGE .....	36
STRUCTURE.....	36
<i>Blueprints</i> .....	38
INTERIOR/CONTENTS OF THE BOOTHS: .....	63
INTERACTIVE ELEMENT: .....	63
RECOMMENDATIONS ON NEXT STEPS .....	64
<b>APPENDIX J: VIRTUAL TOUR .....</b>	<b>66</b>

## TABLE OF FIGURES

<b>Figure 1.</b> Cape Town Museum of Childhood Celebrates Women's Month with 20 Young Children (World, n.d.).....	1
<b>Figure 2.</b> SDG Goal Number 4: Quality Education (The 17 Goals, n.d.).....	2
<b>Figure 3.</b> A Street View Image of the Museum of Childhood in Rondebosch (Google, 2022). ....	4
<b>Figure 4.</b> Concept Design of the Smiley Cart (Calcagni, 2021).....	9
<b>Figure 5.</b> Total Population's Favorite Room; Pre-Existing Helpful Feedback Form; Oct 2021 to Oct 2022 (n=98). Red represents The Red Cross Children's Hospital room and cyan (more vibrant blue) represents the From Rights to Reality room. ....	14
<b>Figure 6.</b> Favorite Exhibit Results from Helpful Feedback Survey (n=18). Red represents The Red Cross Children's Hospital room.....	15
<b>Figure 7.</b> Most Utilized Exhibit from Helpful Feedback Survey (n=18). Red represents The Red Cross Children's Hospital room.....	16
<b>Figure 8.</b> Most Informative Exhibit from Helpful Feedback Survey (n=17).....	16
<b>Figure 9.</b> Concept Map of Interview Findings.....	18
<b>Figure 10.</b> Immersive Story Booth CAD Rendering.....	20
<b>Figure 11.</b> Main Page of the Virtual Tour (Reproduced with permission). ....	21
<b>Figure 12.</b> Immersive story booth below out rendering, showcasing the five sections of the mobile exhibit .....	37
<b>Figure 13.</b> Still Image of the Mandela and Children Exhibit from the Virtual Tour.....	66



## TABLE OF TABLES

<b>Table 1.</b> Combined Characteristics of an Effective Family-Friendly Exhibit (Calcagni, 2021).....	8
<b>Table 2.</b> Estimated Material Cost (wood cost were projected based on Somerset Timbers price catalog)	39

# 1 INTRODUCTION

Established in 1852, Cape Town is seen as the mother city of South Africa, and the second largest city in the country. It is known for its vibrant arts, culture, and community that enriches the lives of its nearly 4 million residents (Statistics South Africa, 2011). One of the many cultural opportunities available to city residents is the Cape Town Museum of Childhood. Opening in October of 2021, the museum provides new and exciting learning opportunities for young individuals in the region. The space is designed for people of all ages to explore their creativity and to learn about the importance of childhood in a fun and engaging way. The museum has a focus on culture and heritage, as well as maintaining stories passed down through generations (see *Figure 1*).



**Figure 1.** Cape Town Museum of Childhood Celebrates Women's Month with 20 Young Children (World, n.d.).

Having a physical location for visitors in Rondebosch has allowed the museum to reach a larger audience. That being said, easy access to the exhibits is limited to more affluent residents living in close proximity to the museum. The city of Cape Town experiences significant economic and geographic divisions which isolate less privileged populations and limit their access to certain resources like the Museum of Childhood. These divisions are in part due to the

history of apartheid in South Africa. It is important for the Museum of Childhood to reach communities where remnants of apartheid are still prevalent and create disparities in educational opportunities, such as in District Six, which lost 60,000 inhabitants to forcible removal. Through outreach programs, the museum has been able to increase the scope of their audience, but gaps in accessibility still exist. The Cape Town Museum of Childhood looks to address this painful reality by providing opportunities for engagement with the museum’s programs. Therefore, the goal of the project was to collaborate with the Museum of Childhood in developing a mobile exhibit platform to share the museum’s message of celebrating childhood with communities outside their reach.

To meet this goal, we identified the following objectives:

- assess the community’s interest in a mobile exhibit platform
- identify the potential message of the mobile exhibit
- design a mobile exhibit prototype with the potential to provide new learning opportunities for community members across the city of Cape Town

The project goals also align with the UN Sustainable Development Goal of achieving quality education, which aims “to promote lifelong learning opportunities for all” (Goal, n.d.).



**Figure 2.** SDG Goal Number 4: Quality Education (The 17 Goals, n.d.).

To achieve the first objective, we gathered survey responses from museum visitors to analyze what was currently working, and we interviewed representatives from the Parent Centre to gather perspectives from the target audience. These interviews, as well as CECD staff interviews, were used to help identify potential messages for the mobile exhibit. All the collected data and perspectives were analyzed as a unit to develop the blueprint for a cohesive and relevant final product. By following these methods to achieve the three objectives, we were able to create a mobile platform prototype that benefited the Cape Town Museum of Childhood and increased their outreach.

## 2 OVERVIEW OF MUSEUM ACCESS AND OUTREACH

This chapter provides an in-depth overview of critical research that has been conducted on relevant topics to the project. First, we discuss the educational and socioeconomic benefits the project can address in target communities and highlight key stakeholders of the museum initiative. The next sections address areas of research important to understanding the project's goal of providing access to interactive experiences. Finally, two case studies will again highlight the importance of interactivity as well as provide a set of important mobile platform "criteria" which can be applied to this project.

### 2.1 PROMOTING EQUAL OPPORTUNITIES AFTER APARTHEID ERA

Cape Town is known for its rich and diverse communities. Still evident today though, are the violence and social disparities which emanated from the country's history. The colonization of Cape Town divided communities and forced segregation from the early 19th Century. Using "Public Health" as an excuse, racist forces pushed Black and Colored populations out of their homes. Infamously, District Six saw inhabitants forcibly removed, marking the beginning of displacement in the 20th Century (*Cape Town the Segregated City*, n.d.). In 1966, the Group Areas Act even proclaimed District Six a "white only" area with local residences destroyed by bulldozers. These atrocities continued into the mid 20th Century. It was only by the early 1990s that pressure from within South Africa as well as economic divestment and outcry from the international community led to the dismantling of the apartheid state, but repercussions have remained for residents 25 years later (Lemanski, 2006).

One effect of apartheid is the significant wealth disparity across Cape Town and the country as a whole. According to the World Inequality Report in 2021, the wealthiest top 10 percent of people in South Africa own 86 percent of the country's total wealth, while the bottom 50 percent own a negative amount of the total wealth, meaning they have more debt than resources (Heywood, 2021). Economic resources are a key factor in determining the range of opportunities available to a person. A study performed in five low- and middle-income countries found that children from low socioeconomic status (SES) backgrounds who placed in the 80th percentile of a standardized test at the age of 12 completed similar years of schooling as children from high SES backgrounds who placed in the 20th percentile of the same test (Das et al., 2022). These findings demonstrate that children from families with low SES have educational and opportunistic limitations, even if they initially perform better than their wealthier classmates. For this reason, providing opportunities for low-income families to access the same resources and experiences for their children is of utmost importance.

In addition to tangible repercussions, apartheid left behind a legacy of significant generational trauma. A study conducted by Jené Pretorius analyzes a series of interviews with South African caregivers who were alive during apartheid. The participants were diverse, but the researchers noted two common themes throughout the conversations: race was a key determinant of a person's experience with trauma and violence, and younger generations do not have the same historical perception of race as generations who experienced apartheid (Pretorius et al., 2021). There is significant generational trauma which many experienced during their childhood growing up into the apartheid era. Even though today's children are not directly affected by the consequences of apartheid, it is integrated into their lives through the social and economic



disparities present across the country, which pose a variety of new threats to childhood and children. For this reason, working to promote equal access to cultural experiences and opportunities and informing children about their rights and their importance is a crucial task which the Museum of Childhood hopes to work towards.

## 2.2 EXPANDING THE EDUCATIONAL REACH OF THE MUSEUM OF CHILDHOOD

The Cape Town Museum of Childhood is dedicated to the exploration and celebration of childhood. Specifically, the founding mission for the organization is to “provide an institution for the heritage, documentation, memory, oral history, research, and interpretation of childhood” (Home, n.d.). The museum focuses on educating its guests about the importance of supporting childhood, children’s rights, and the safety of children.

The Museum of Childhood has occupied its physical location in Rondebosch since October of 2021, after first operating as a mobile museum for five years. While early traveling exhibits were successful for the organization, the museum board hoped to gain more traction in the community with the development of a permanent location, which was acquired in 2015 (see *Figure 3*) (“Museum of Childhood to Launch,” 2015). The venue has been a success since its opening, attracting a multitude of visitors and reaching a larger population than expected by the CECD (Viljoen, 2021). The museum strives to offer a fun and educational experience for any visitor who walks through their doors.



**Figure 3.** A Street View Image of the Museum of Childhood in Rondebosch (Google, 2022).

Even given the overarching success of the physical space, the museum’s Project Manager, Sarah Atmore, and the other leadership recognize that they are not reaching critical populations. Physical and financial barriers prevent those who live farther away or who live in poorer communities from experiencing what the Cape Town Museum of Childhood has to offer.

The development of a mobile museum exhibit could bridge these gaps. While museum entry is free, the cost and time of transportation to and from the museum can be limiting factors for many families. A mobile unit could share key highlights of the museum, which include the heritage of childhood, childhood's role in society, and awareness on childhood hardships across the city and the world (Home, n.d.), The mobile exhibit also has the potential for drawing in new visitors who otherwise might not have known about the museum's physical space. Children from across the city have a lot to gain from the development of mobile museum exhibits which can provide fun and engaging activities. In the long term, this can promote joy for learning and a deeper connection to cultural enrichment offered by the museum.

A successful outreach program can draw attention to new areas of the city as well as to the physical museum in Rondebosch. In the long term, the exhibits can become a source of cultural and educational information that honors and celebrates childhood.

### 2.3 EDUCATION OUTSIDE OF THE CLASSROOM

Discovering effective modes of education is an important and ever-growing field of study. Keeping children engaged is a critical challenge for effective teaching both inside and outside the classroom. One common understanding is that students cannot fully engage with educational material presented in an unappealing way. A study completed by Alison Gopnik, confirmed that children learn more effectively when presented with interesting and interactive teaching techniques. In her experiment, children were tasked with remembering details of a bedtime story. Some in the group were presented with pictures to accompany the story while others just listened. The results showed that the children who listened to the story with images remembered more and were generally more interested in the topic than the children who did not see the images (Goddu et al., 2020). Gopnik's experiment proves that the more effective way of learning is to engage with the children in effective ways. This way of thinking is also adopted by the Early Language and Literary Initiative (ELLI) which is located in the Stepping Stones Museum for Children in Norwalk, CT. Making interactive and easily accessible exhibits that promote the students' curriculum has the benefit of substantially boosting a child's knowledge on a subject, as well as their passion for learning (Raynolds et al., 2019). These studies on the importance of interactivity will be utilized when designing and creating our mobile platform in Cape Town.

Developing a healthy relationship between children and learning at a young age is key to their growth. Interactive museums allow for this relationship to progress and spark interest in different career paths for children. The book, *Challenging the Classroom Standard with Museums*, touches on the Fleet Science Center, who incorporated paper airplanes to teach the history of aircrafts (Pumpian et al., 141). Children are more able to take an interest in specific subjects such as aircraft when exposed at a young age in an interactive way. A study done by Maria Marcus and Catherine Haden proves that having an interactive museum experience helps children adhere to specific subjects (Marcus et al., 2017). Marcus and Haden state that, "children who spend time in science-related museum exhibits tend to show more interest in STEM[...]" (Marcus et al., 2017). Children having an interest in specific fields provides the building blocks needed for later in life. This way of learning allows children to come to their own conclusions, which is important for early education (Pumpian et al., 140). Marcus and Pumpian both applaud the interactive approach to learning. These two examples provide useful perspectives to consider

when developing the mobile exhibit. They show that interactive learning is effective, museums are great producers of this interactivity, and such learning can open career paths for children.

## 2.4 CONSIDERATIONS FOR CREATING A MOBILE MUSEUM

In the past, most traveling museums have been implemented on a larger scale than what we are proposing to the Cape Town Museum of Childhood. Often taken on by bigger museums or non-profits, mobile exhibits feature tours across continents and large exhibits (Barge et al., 305). Despite this, there is still much to learn from what has been implemented by other organizations.

Traveling exhibits are designed to meet specific considerations. Exhibits frequently use materials that can be transported by trailer, only relying on space and electricity to be provided. Exhibits also tend to depend heavily on images and graphics as language barriers become more prominent as the reach of an exhibit expands. Any writing often takes the form of short paragraphs on posters to relay information in a portable format (Chamberlin, 2010).

An exhibit being mobile also gives it some unforeseen advantages. The traveling aspect of the exhibit presents the ability to fact check certain information by bringing the museum directly to the appropriate communities whose experiences are represented. In an example from Chamberlin, the exhibit on the Native Nations of Louisiana was brought to local tribes to request feedback. In one instance, cultural representative Linda Langley corrected the museum on misinformation about effigy baskets (Chamberlain, 2010). To validate the mobile exhibit, it can travel around to local experts to inspect any information that is going to be presented on local culture or history. Our exhibit will take all of these considerations into account when designing and utilizing our mobile platform in Cape Town.

## 2.5 RELEVANT CASE STUDIES IN MOBILE MUSEUM EDUCATION PILOTS

Mobile and interactive exhibits can take on a lot of different shapes and sizes. Museums from all over are trying to take a more interactive approach to exhibits to help visitors learn and stay more engaged. When designing new exhibits and exploring new ideas, we can learn from exhibits and design processes that have been tested (Chamberlin, 2010). Specifically, looking at aspects that have been successful and are being implemented in other museums. The following case studies provide specific criteria and level of interactivity for designing a mobile exhibit.

### 2.5.1 CASE STUDY ON IMPACT OF TRAVELING MUSEUM EXHIBITION ON STUDENTS FROM LOW-INCOME HOMES

Museums and schools are both institutions for learning. It is becoming more apparent that school field trips allow rural students to make real-life connections with their school curriculum, giving them the opportunity to make deeper connections and understand more difficult topics. Created in 2013 by the United States Holocaust Memorial Museum (USHMM), the exhibit, *Fighting the Fires of Hate: America and the Nazi Book Burnings*, explored the event surrounding May 10th 1933, where university students in Germany burned thousands of books, becoming a symbol of America's battle against Nazism. This exhibition included themes such as freedom of expression, democracy, citizenship, and Holocaust education (Badger & Harker, 2016). A great

deal of thought and planning went into the creation of this exhibition, with four goals in mind: to use history as a starting point for thinking about the nature about both Nazi dictatorship and American democracy, to challenge students to think about ‘big picture’ consequences, to confront students with the consequences of indifference, and to motivate students to think critically about the democratic society in which they live in (Badger & Harker, 2016). This study’s objective was to explore the impact of the exhibition on students from poor, rural backgrounds, discussing how it helped them to engage with the themes presented. Students from five different middle schools in the United States responded to this traveling museum exhibition hosted at a non-museum site (Badger & Harker, 2016).

This study raised two questions: “How did middle school students’ experience on the field trip impact their teachers’ perceptions of their learning?” and “What is the educational impact of the USHMM traveling exhibition on the middle school students?” (Badger & Harker, 2016). It was ultimately found that a culturally engaging exhibition at a rural, non-museum host site can have a positive impact on teachers’ perceptions of their students’ abilities. It also provides opportunities for learning which go beyond the school curriculum. The students walked through the exhibition, were given a short tour, and then visited a “Writing Wall” where they responded to a question on an index card. More than 1,100 students from five public middle schools and 1 high school visited the USHMM exhibition (Badger & Harker, 2016). Through surveying the participants, the authors suggested that students connected content learned from this exhibition to contemporary, real-world issues. A recurring theme in their responses was that one of their favorite children's books had been either banned or burned, allowing them to personally connect to the history.

This was a successful case study showing that participation in culturally enriching experiences, like field trips, can have a very positive impact on a students’ academic achievement. As this example shows, it can also spark an interest in learning more about the Holocaust or other issues presented in the mobile exhibit. The role of a traveling exhibition is not to replace a visit to a museum, it is to expand its geographical and educational outreach and to inspire interest in learning more (Badger & Harker, 2016). Museums can remain relevant by responding to an increasingly diverse society by developing relationships with various ethnic, cultural, and economic communities. Traveling exhibits have the potential to reach underserved communities and to provide an educational and cultural experience for students from poor, rural backgrounds (Badger & Harker, 2016).

### 2.5.2 FAMILY-FRIENDLY MOBILE EXHIBIT FOR WORCESTER HISTORICAL MUSEUM

The objective of this case study was to design a family-friendly, interactive, mobile exhibit called *Smiley Cart* with the goal to distribute smiley buttons to educate the public about the *Harvey Ball*, a charity function held annually in Worcester, MA. The Worcester Historical Museum wanted to address the lack of knowledge surrounding the Harvey Ball and Smiley Face design, along with the lack of awareness about local history in the area (Calcagni, 2021). Very similar to what we plan to do, this museum initiative achieved its goal by exploring past museum exhibits, design processes, and the local area and history.

There are many characteristics that help define a successful exhibit. According to this study, there are seven characteristics of a family-friendly exhibit defined by Philadelphia/Camden Informal Science Education Collaborative (PISEC). These include multi-sided, multi-user, accessible, multimodal, readable, and relevant (Calcagni, 2021). These

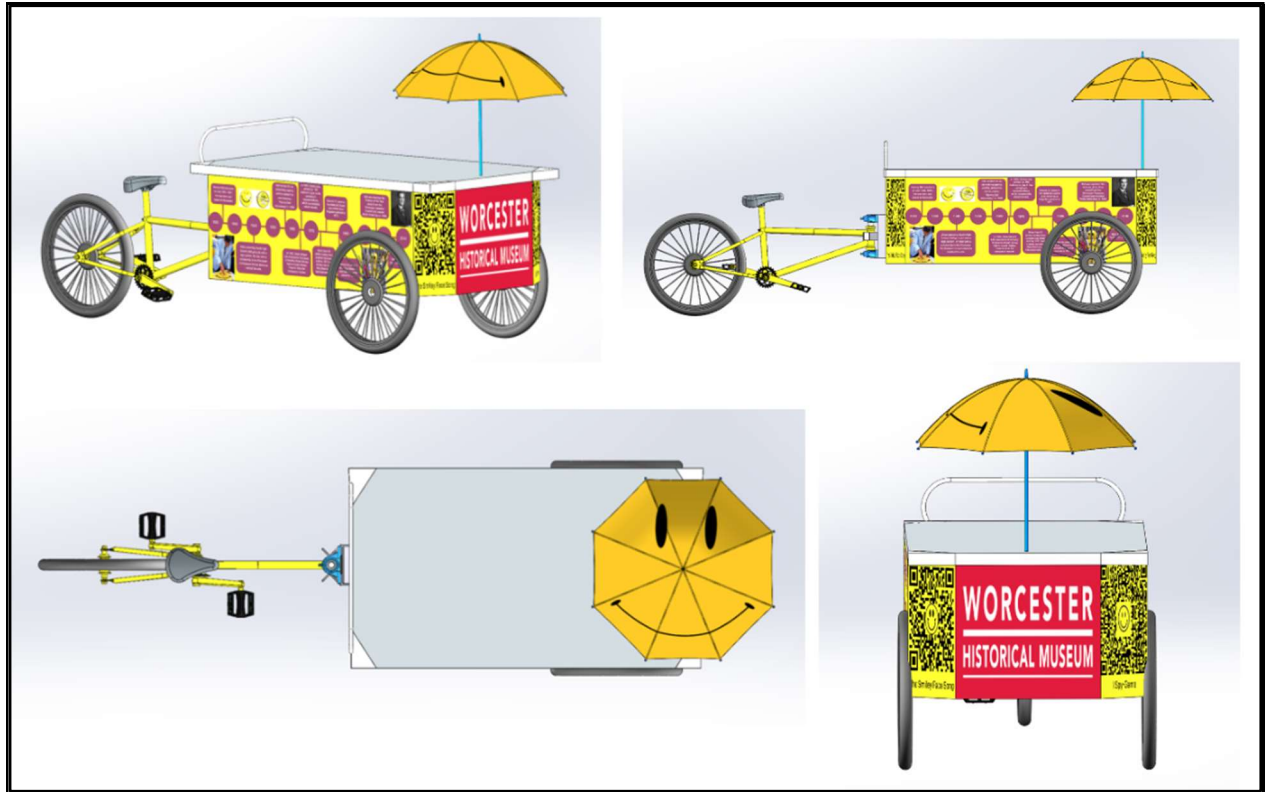


characters represent the goals of all family-friendly exhibits, but not all family-friendly exhibits are effective. Table 1 shows a set of combined characteristics that this research group derived for creating an effective, family-friendly exhibit.

**Table 1.** Combined Characteristics of an Effective Family-Friendly Exhibit (Calcagni, 2021).

Combined Characteristics	Description
Multi-sided	"family can cluster around the exhibit"
Multi-user	"interaction allows for several sets of hands (or bodies)"
Accessible	"comfortably used by children and adults"
Multi-modal	"appeals to different learning styles and levels of knowledge"
Readable	"text is arranged in easily-understood segments"
Relevant	"provides cognitive links to visitors' existing knowledge and experience"
Curiosity	Visitors want to engage with the materials presented
Challenge	Brings out strong reactions, emotions, or provokes thought
Participation	Intrigues both physically and dialogically
Narrative	Story is told in a way that the audience can be invested in and learn from

The team developed a Computer Aided Design of the *Smiley Cart* and family-friendly activities to be used with the mobile cart, combining both entertainment and educational aspects. *Figure 4* (below) shows the final designs of the cart, featuring a Smiley Face umbrella, Harvey Ball timeline, and QR codes for the Smiley Face song and I-Spy game. The vehicle design allows the Worcester Historical Museum to be impactful and accessible in daily Worcester activities, easily increasing its presence and outreach in the city. The structure of the cart has also been carefully planned, considering both cost and convenience. One of the main takeaways from this case is that the goal for all exhibits is to make the audience feel welcomed and comfortable. Research shows that having an inviting and approachable exhibit will make visitors feel at home and they will be comfortable to explore the exhibit to their liking (Calcagni, 2021).



**Figure 4.** Concept Design of the Smiley Cart (Calcagni, 2021).

## 2.6 SUMMARY

Synthesizing the information on the location, the museum, and the current state of research in museum education, there are a few important takeaways which will guide the development of our mobile exhibit. Firstly, it is evident that our success will be dependent on our ability to assess the specific wants and needs of both the target populations and the sponsor. The project must benefit both parties involved while minimizing the risks involved for all participants. The exhibit should also consider the social context in which it will be placed to maximize its effectiveness. Another key takeaway is that to be as effective as possible, the exhibit should be mostly, if not completely, interactive. As outlined throughout the proposal, children are more receptive to and engaged with new information when it is presented in non-traditional ways. To capitalize on the resources and energy put into the mobile platform, it will need to be developed in a way that has interactivity at its core. Overall, the research demonstrates that a successful mobile exhibit will be culturally and socially aware, therefore our project aims to adopt all these characteristics.

### 3 METHODOLOGY

The goal of the project was to collaborate with the Museum of Childhood in developing a mobile exhibit platform to share the museum's message of celebrating childhood with communities outside their current reach.

To meet this goal, we identified the following objectives:

- assess the community's interest in a mobile exhibit platform
- identify the potential message of the mobile exhibit
- design a mobile exhibit prototype with the potential to provide new learning opportunities for community members across the city of Cape Town

This chapter provides an overview of the methods we used to achieve each objective.

#### 3.1 ASSESS THE COMMUNITY'S INTEREST IN A MOBILE EXHIBIT PLATFORM

The first objective for meeting the project goal included assessing the specific interests of the mobile exhibit's audience. Doing so was a multistep endeavor evaluating the interests of both the museum's current audience and the museum's potential audience. Understanding the values of current visitors helped us determine what parts of the museum were most interesting and engaging. These visitors were not the target audience of our mobile exhibit though, so gaining an understanding of what children and parents in harder to reach communities are interested in was also crucial to the project's success.

Evaluating the interest in current museum exhibits provided us with a starting point from which we could base the mobile exhibit. From the literature review, we determined that the most successful mobile museum platforms involve high levels of engagement through interactivity (Badger & Harker, 2016). Assessing which exhibits visitors found most captivating aided in choosing a successful mobile experience.

The museum already utilized feedback forms and visitor surveys, which provided a baseline idea of what the most popular rooms were in the museum. These forms ask for the visitor's name and age and ask them to draw their favorite part of the museum. An example of this form is included in *Appendix A*. To develop the mobile exhibit platform though, a greater range of information about current visitor experiences was needed. The first way we collected this data was through a voluntary survey of museum visitors, or "helpful feedback forms." This survey still included asking visitors about their favorite exhibit, but it also provided information about which exhibits each visitor found most engaging and most informative. The survey was available to visitors while at the museum and asked them questions about their experience. The survey was also posted on the museum's social media sites to collect more responses. Data from this survey provided a baseline for how different age groups of visitors perceive the museum and its exhibits. *Appendix B* contains a link and QR code to the museum visitor online survey.

It was also important for us to recognize exactly what the potential audience might want out of a mobile exhibit. The sponsor helped identify specific points of contact within the following target audience populations: The Parent Centre (an organization which supports healthy parenting and caregiving in low-income communities), librarians, and teachers/principals who are not already involved in outreach programs. After introductions from the sponsor, informational interviews were performed with each identified individual. A full list of interviewees is given in *Appendix C*, and the utilized interview questions can be found in

*Appendix D* (Parent Centre), *Appendix E* (librarian), and *Appendix F* (principal). The conversations focused on each person's unique perspectives and understanding of the people (especially the children) in communities they work with. Interviews with these individuals allowed us to gain a better understanding of the target communities and provided us with a link to the target population. Overall, this collection of interviews provided context as to what the potential recipients of the mobile museum platform would like to see and what would be most beneficial to them, which helped direct the development of the mobile exhibit prototype.

### 3.2 IDENTIFY THE POTENTIAL MESSAGE OF THE MOBILE EXHIBIT

As part of the message development, we conducted a baseline assessment of the museum's assets for this project. We determined what types of messages already existed within the museum and what resources were available to respect the museum's time and resources. Once the assessment was complete, we transitioned into identifying new ideas for a mobile exhibit message.

To better understand our sponsor's preferences on the message of the mobile exhibit and define how the platform will develop, we conducted interviews with key staff who work at the museum and with the CECD. These conversations helped us learn from the curators and educational staff who have experience with the process of bringing the message of celebrating childhood into the community. Our interviews included questions about the museum's educational mission and about how to reach community members as effectively as possible. We conducted open-ended free narrative interviews with the museum employees. This means that we provided the participants with questions, that they are free to answer in whatever way they see fit (Cochrane, 2014). *Appendix G* includes the list of questions that we used to guide these conversations. Part of our assessment was determining what story should be told, to accomplish this we talked with employees specifically about their experience with the museum's current and past outreach programs. As the museum used to operate solely on a mobile platform, these individuals had important insight on what it takes to bring the museum's message of celebrating childhood to various communities.

### 3.3 DESIGN A MOBILE EXHIBIT PROTOTYPE

To design the mobile exhibit, we first analyzed the results of all collected surveys and interviews. This involved combining survey data into a series of tables and charts and coding the interviews to pick out common themes and patterns throughout participant responses. The results of these analyses were used furthermore to inform the development of the mobile exhibit.

The Cape Town Museum of Childhood is already home to a successful outreach initiative where they partner with other organizations and schools to provide programming. Part of the design process for these programs, as well as for new exhibits, includes answering a set of thought-provoking questions provided in a Designer Template. We used this template to brainstorm and eventually refine the mobile exhibit's main message and physical concept. Because this template was used in the design of most rooms and programs present in the museum, it allowed us to ensure the design process and results were developed to be consistent with the existing exhibits. *Appendix H* includes examples of filled out pages in the Designer Template.

As an additional element to the project, we also developed a virtual tour of the museum. With the assistance of a 360 GoPro camera, we were able to capture each exhibit within the Museum of Childhood. Using an online platform called Kuula, these photographs, as well as with close up, 2D images of posters throughout the exhibit, were stitched together to create an interactive virtual tour of the museum. This resource could be linked to the mobile exhibit through a QR Code that can be accessed through any modern phone. Along with being able to share the main message of the children's museum to anyone with access to the internet, the virtual tour can act as a preview for the museum, building interest within the community.

## 4 FINDINGS AND DELIVERABLES

Through various data collection and analysis methods, we were able to compile a set of important findings which informed the development of our final project deliverables. This chapter provides an overview of our findings and the final product. We will first present information about the popularity of each existing room in the museum, and the most informative and engaging exhibits for different age groups. We will then introduce our findings on the limitations of pre-existing projects, the potential mobile exhibit messages, and the ideas for its implementation which were found from staff interviews. Finally, we will detail the process of compiling all collected data which allowed us to develop a set of concepts that transformed into a detailed plan for exhibit execution.

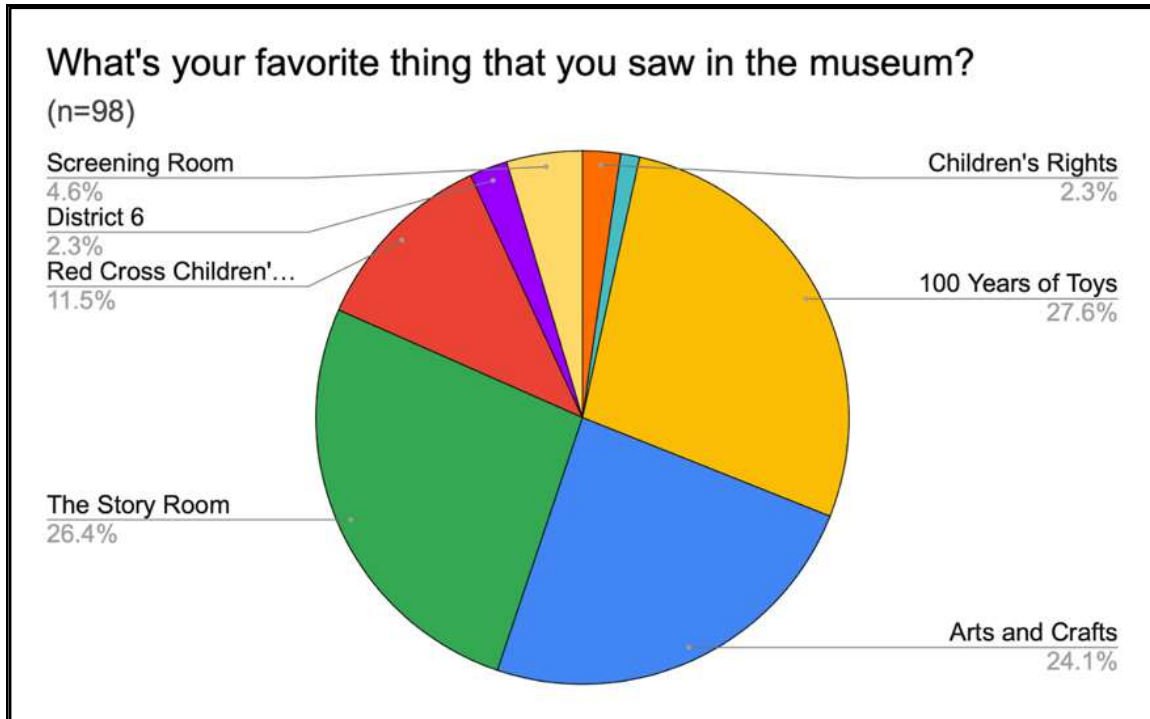
### 4.1 COMMUNITY'S INTEREST IN A MOBILE EXHIBIT PLATFORM

Before developing and designing the mobile exhibit, it was crucial for us to understand the museum's audience. This involved assessing what current visitors enjoy about the museum through feedback surveys as well as assessing what the target audience would like to see in the exhibit.

#### 4.1.1 VISITORS' FAVORITE EXHIBITS

Upon arrival at the museum, it was important for us to find out which rooms in the museum were the most enjoyed by visitors, as this information provided insight on what exhibits were most successful and what types of activities were more likely to draw attention. The Museum of Childhood already had a pre-existing survey, found in *Appendix A*, which they distributed to visitors. This simple survey asked visitors (specifically the children) for their age, their favorite color, and some of their interests. The museum received 98 completed surveys from October 2021 to October 2022. We then analyzed the data collected and found there was one question that asked each child to draw their favorite exhibit which proved to be particularly useful. We interpreted the drawings from the 98 visitor surveys and compiled the data into the pie chart shown in *Figure 5* below.

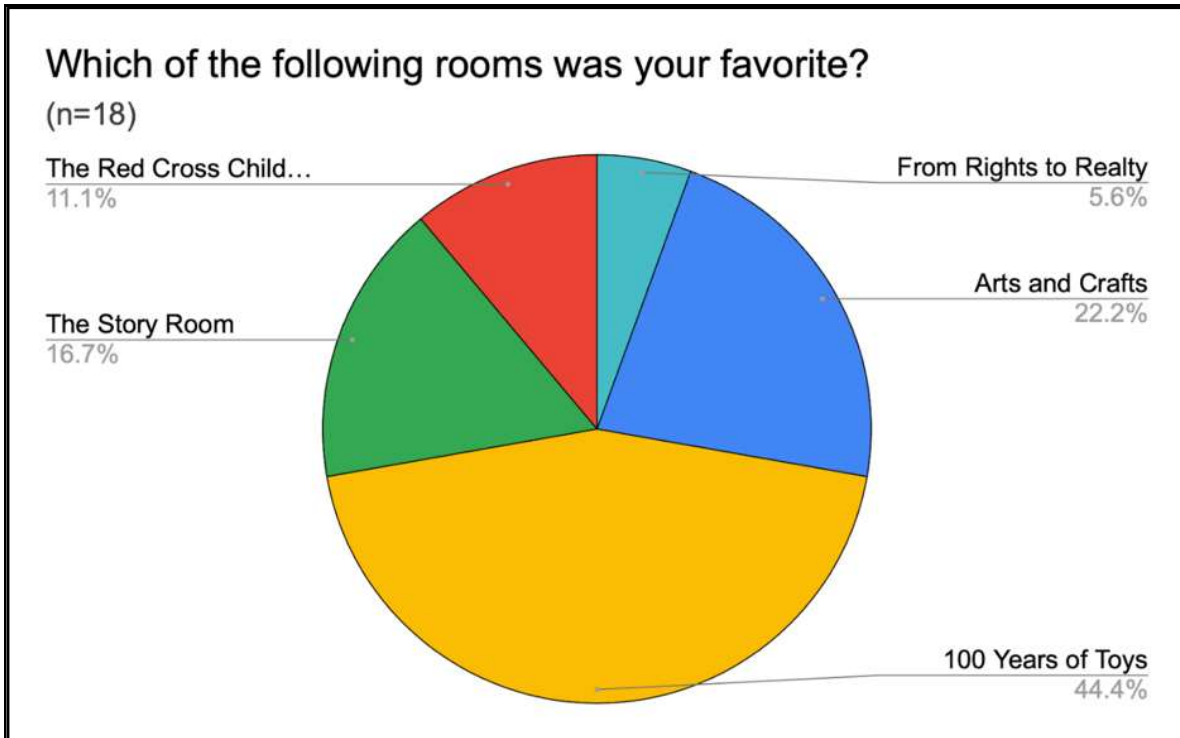




**Figure 5.** Total Population’s Favorite Room; Pre-Existing Helpful Feedback Form; Oct 2021 to Oct 2022 (n=98). Red represents The Red Cross Children’s Hospital room and cyan (more vibrant blue) represents the From Rights to Reality room.

The results shown in *Figure 5* cover a wide variety of ages ranging from two to eighty-three. The overall favorite room for all visitors who filled out the survey was the “100 Years of Toys” room, with 27.6% of votes. This was followed closely by the “Story Room” (26.4%) and the “Arts and Crafts” room (24.1%). It is important to note that, of these responses, 72.4% were between the ages of 4 and 12. Because most of the survey results were from young children, the conclusions drawn from these statistics favor that age range. The responses from visitors outside this age range still mainly favored the three exhibits mentioned above. From this data, we concluded that exhibits which involve physical interaction from the visitor are most well-liked by the museum’s audience.

The results of the pre-existing survey were useful, but we had additional clarifying questions to ask the current audience. Within the new Helpful Feedback Form (see *Appendix B*), we included questions about each visitor’s favorite. The results from our survey are shown in *Figure 6*.

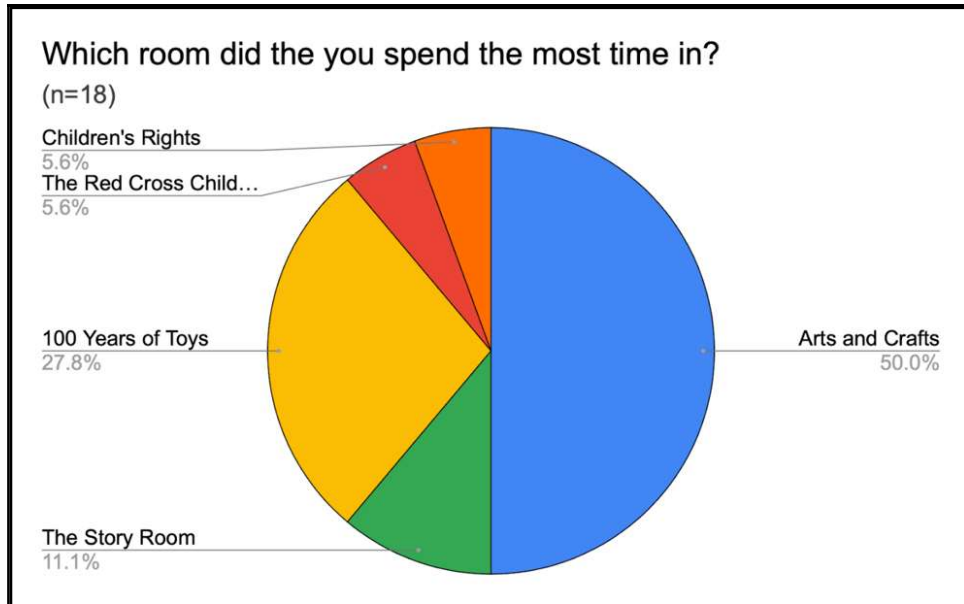


**Figure 6.** Favorite Exhibit Results from Helpful Feedback Survey (n=18). Red represents The Red Cross Children’s Hospital room.

The data represented in *Figure 6*, which was collected between October 31st and November 19th, supplemented the results from the Pre-Existing Helpful Feedback Form. Of the 18 responses collected, the most popular exhibit was the “100 Years of Toys” room (44.4%), followed by the “Arts and Crafts” room (22.2%), and the “Story Room” (16.7%). The most popular exhibit was the same between the two surveys, and the second and third most popular exhibits were switched. Though there is slight variation between the two survey responses, the three most popular exhibits overall remained the same. These three exhibits are the most interactive rooms in the museum, providing proof that interactive elements draw visitors in. Knowing which types of exhibits were most popular among visitors proved to be very insightful when brainstorming designs for the mobile exhibit that could attract and engage visitors of all ages.

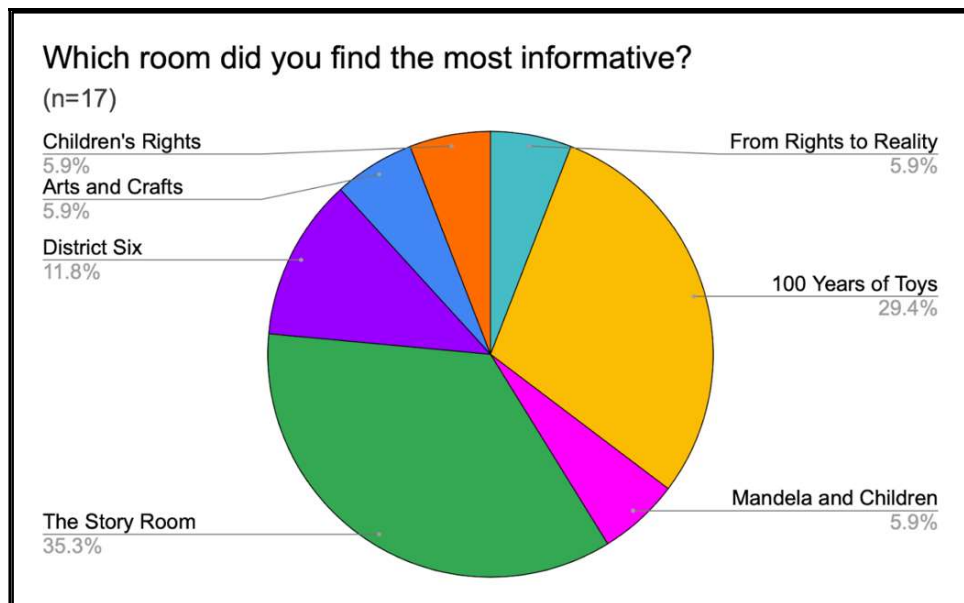
#### 4.1.2 ADDITIONAL VISITORS’ EXPERIENCES

The survey we implemented also provided information on which rooms the visitors spent most of their time in, and which rooms they thought were most informative. The results from these survey questions are shown in *Figure 7* and *Figure 8* below.



**Figure 7.** Most Utilized Exhibit from Helpful Feedback Survey (n=18). Red represents The Red Cross Children’s Hospital room.

Figure 7 shows which exhibits the respondents spent the most amount of time in. Of the 18 surveyed visitors, 50% spent the most time in the “Arts and Crafts” room. The next most popular exhibit was the “100 Years of Toys” room (27.8%). Combined, these two exhibits account for over 75% of the polled audience. Overall, the results show that exhibits which allow the visitor to perform some sort of hands-on activity are able to engage visitors for longer periods of time. This again supports the previously made conclusion that successful exhibits incorporate physical interaction.



**Figure 8.** Most Informative Exhibit from Helpful Feedback Survey (n=17)

*Figure 8* shows the survey results for what room the visitors believed was most informative. Of the 17 responses, the most popular answer was “The Story Room” (35.3%), followed by the “100 Years of Toys” room (29.4%). These results show that visitors feel they learn most when information is presented as a story. This led to the conclusion that storytelling can be an effective way to engage visitors of all ages and is an important element to include in the design of a mobile exhibit.

#### 4.1.3 FOSTERING CONVERSATIONS BETWEEN PARENT AND CHILD

From the Parent Centre interviews, one important issue addressed was the disconnect between parents and their children, especially among young parents. This issue was reinforced during our interview with Benita Cornelius, principal of Christian David Moravian, who stated that a major issue facing many of her students has been dealing with household dysfunction. Each of these interviewees emphasized that, as time progresses, the disconnect between parent and child can grow and cause deeper rooted issues for both parties. For this reason, it is important to create opportunities for connection and increased understanding between parents and their children. Both Benita and the Parent Centre representatives emphasized the idea that children should not be alone, and that they should be aware that there are people who love them. We hope that, through fostering conversations about important issues, this project has the potential to increase the amount of understanding between family members.

During the interview process, we also spoke with Margaux Bergman, a librarian at Pinewoods Public Library in Cape Town. Her perspective was valuable, as libraries were identified as a potential site for the mobile exhibit. Bergman had experience working with museums in the past, both as a museum staff member and as a point of contact for the libraries she has worked at. This gave her a unique and extremely useful perspective for the project. She explained what outreach programs usually look like within a library setting and informed us that these types of programs usually consist of a 30-minute guided program. Benita Cornelius also mentioned in her interview that children love to interact and spend time with exhibits when given the opportunity, whether that be a guided interaction or not.

Based on these interviews, we concluded that it would be useful to incorporate some form of activity within our mobile exhibit. Because of the nature of mobile exhibits, the activity should not be too complex in nature to require significant explanations. Atmore (Project Director of CTMoC) also spoke to the importance of the mobile exhibit being able to stand alone to account for staffing concerns. To address the insights from Bergman, Cornelius and Atmore, the mobile exhibit was developed to allow for an interactive activity that is not reliant on the presence of museum staff members.

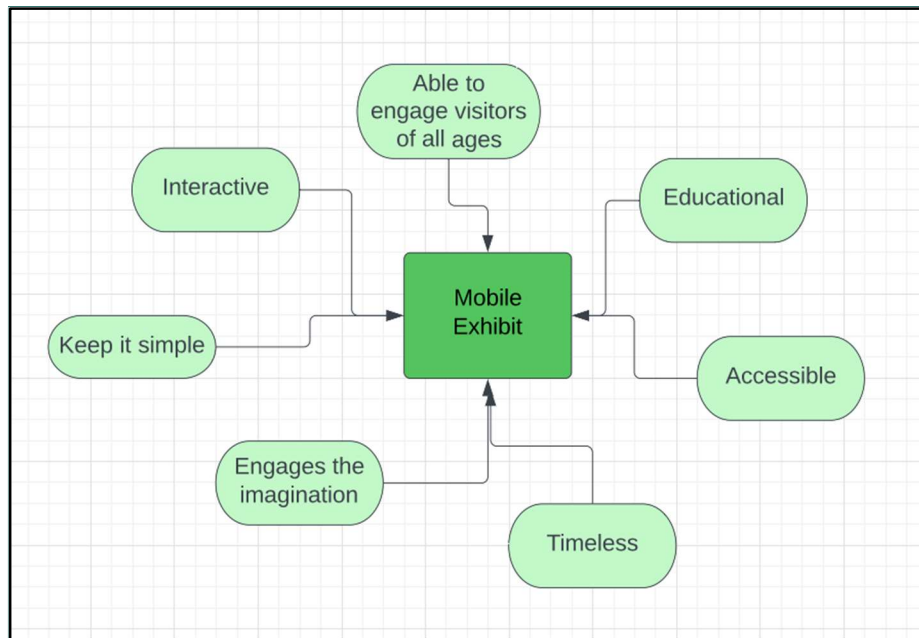
Overall, the target audience interviews provided us with an understanding of the importance of fostering the parent-child relationship and highlighted the need for interactivity within the mobile exhibit.

## 4.2 MESSAGE OF THE MOBILE EXHIBIT

In analyzing the interview data, there were a few common themes presented multiple times across our conversations with staff. Firstly, there was the idea that childhood is a lifelong experience. As brought up during multiple interviews, the museum wants to enforce that childhood lasts from ages zero to one hundred, meaning, no matter a person’s age, they can still

experience the joy of being a child. Multiple interviewees also brought up the importance of showing how people of various generations and backgrounds can be similar while also celebrating their differences. Other themes included celebrating childhood, understanding the scope and importance of childhood rights and safety, and inequality. While we may not have incorporated all the addressed themes into the final product, discussing them helped inform our design process and gave a greater understanding of the museum as a whole.

In addition to speaking about potential messages and themes for the mobile exhibit, we asked participants more specific questions about what the exhibit should look like. The responses to these questions were not as cohesive across participants, but there were a few key takeaways, shown in *Figure 9*. In the opinions of the staff, the exhibit should engage visitors of all ages (specifically children and their parents) as well as engage multiple senses, it should incorporate some combination of education and play, and it should be simple enough in design so that it can be easily constructed and transported. Each of these responses represent key attributes of the ideal exhibit and were taken into consideration in the design of the mobile exhibit.



**Figure 9.** Concept Map of Interview Findings

The final category of questions addressed in the interview had to do with logistic considerations for the mobile exhibit. We discussed whether or not the exhibit should be staffed, how much time the exhibit should engage visitors, and how long the exhibit should remain at each location. The only discernable pattern among the responses for these questions was that the answers are dependent on what the goal of the exhibit will be. Because of this, we were unable to obtain significant data from these responses, but the lack of patterns placed an emphasis on developing the exhibit message before beginning the design process.

### 4.3 DESIGNING A MOBILE EXHIBIT PROTOTYPE

After reviewing all the interviews and surveys discussed above in conjunction with prior research outlined in the background chapter, we settled upon the following main message: ***Celebrating diverse childhood stories***. This message encompasses the themes of celebrating and maintaining childhood, and it creates an opportunity for celebrating cultural differences within Cape Town by incorporating stories from different generations as well as communities. The message was contrived to provoke thought about an individual's own relationship with childhood. The exhibit will be successful if it can start a conversation about childhood between a parent and their child. For example, this could be as simple as a father opening up about certain hardships as a child or a mother sharing an impactful story from her childhood, giving adults a chance to reminisce while the child strengthens their relationship with their parents.

After speaking with Michaela Ashley-Cooper and Bridget Kahts, who were involved with the museum's original traveling exhibitions, we understood the importance of simplicity. Given the current resources at the Museum of Childhood, a complicated exhibit design runs the risk of never being implemented. In their eyes, an exhibit must have minimal set up, be capable of being transported in a medium size vehicle, be made from accessible materials, and be unstaffed when necessary.

We have developed the following ways to represent the messages discussed above, given the physical restrictions: a take on an immersive storytelling booth and a virtual tour. The beauty of storytelling is that it puts the observer in the shoes of the people represented in the exhibit, curating an experience where visitors are especially receptive to the stories being told.

#### 4.3.1 IMMERSIVE STORYTELLING BOOTH

Through the back-and-forth use of the designer template, we eventually settled on the idea of using immersive storytelling booths (pictured in *Figure 10*) to address the chosen message. A complete construction guide and exhibit description is included in *Appendix I*. In summary, the exhibit will consist of four small, enclosed booths. Each booth will be small and compact enough to be easily managed, but still sturdy in structure. Three of the four booths will each highlight a different childhood story or experience from people living in Cape Town. These stories will be aimed to showcase childhood experiences that are representative of the majority of children within specific communities at certain periods in time. We will stray away from celebrities or other stories that are not representative of average experiences within each community. To present these stories the interior of the booth will combine visual, textual, and audio media to create a multi-sensory and completely immersive experience that allows the visitor to truly "step-into" the childhood experiences of another person.

After experiencing the three story booths, the visitors will have the chance to tell their own story in a fourth booth containing an interactive activity. Inside this fourth booth will be a mirror with a message asking people to leave behind their own childhood stories. These individuals will then either draw or write their story on a table outside the booth before proceeding to hang it on the walls of the booth with a clothespin system. At its core, the exhibit focuses on storytelling, both by the booths' subjects and the visitors themselves. Through the immersive experience, the exhibit will address its goal of making its visitors aware of, understanding towards, and empathetic to the diverse childhood experiences of others.



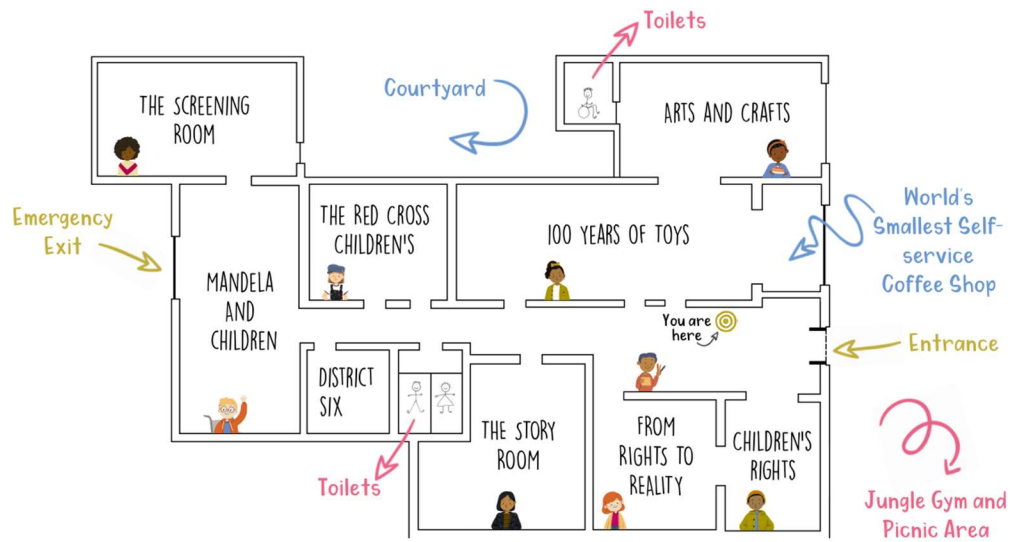


**Figure 10.** Immersive Story Booth CAD Rendering.

#### 4.3.2 EXPANDING ACCESS TO THE MUSEUM THROUGH A VIRTUAL TOUR

During our interview with Eric Atmore, director of the CECD, he noted how valuable it would be for the mobile exhibit platform to somehow connect directly back to the museum. In order to accomplish this, we developed a virtual tour of the museum which can be linked to the mobile exhibit through the use of QR codes. In this tour, the “visitor” opens the link to a map (shown in *Figure 11*) and has the ability to click through all of the rooms to see what the museum has to offer, as well as look closely at certain important posters and artifacts. The tour is not a complete replacement to an in person visit, it provides a way for the museum to reach a much greater audience. *Appendix J* includes a QR code for access to the virtual tour.

WELKOM, WAMKELEKILE, WELCOME, TO THE  
 CAPE TOWN MUSEUM OF CHILDHOOD



**Figure 11.** Main Page of the Virtual Tour (Reproduced with permission).

## 5 CONCLUSION AND RECOMMENDATIONS

This project focused on developing a mobile exhibit with the Cape Town Museum of Childhood with the goal of providing the museum the ability to spread their message within previously unreachable populations. By increasing the number of people who understand the importance of childhood and childhood safety, as well as the number of children who understand their rights, the Museum of Childhood has the opportunity to support the development of a safer and more inclusive childhood experience for young people. To achieve this, we performed a set of surveys and interviews with the current museum audience as well as representatives from the target audience to establish visitor preferences and collect ideas for important messages. We also interviewed staff from the Museum of Childhood and the Center for Early Childhood Development (CECD) to learn about past outreach programs and understand their perspective on how the project might manifest. Using this collected information alongside design tools provided by the sponsor, we developed two main platforms to share the message of *celebrating diverse childhood stories*: immersive storytelling booths and a virtual museum tour. Through implementing these plans, the Museum of Childhood will provide new communities with the ability to experience their organization and celebrate childhood in new and exciting ways.

### KEY FINDINGS AND DELIVERABLES

Using two visitor surveys, we determined that successful and favorable exhibits include elements of physical interaction and storytelling. Interviews with representatives from the mobile exhibit's target audience reinforced the importance of including interactive elements, and also brought about the importance of encouraging connections between parents and their children. The museum and CECD staff interviews covered a range of topics surrounding the contents and design of the mobile exhibit. *Figure 9* provides an overview of the key takeaways from these conversations. Utilizing all the collected data, we were able to use an exhibit designer template to develop the central message of our exhibit: *Celebrating diverse childhood stories*. From here, we were able to develop the deliverables outlined in the sections below.

Two main deliverables were produced from the synthesis of our findings with the purpose of achieving the project goals and conveying the determined exhibit message:

1. A complete mobile exhibit description and construction guide (*Appendix I*)
2. A virtual museum tour (*Appendix J*)

Mobile exhibits and virtual tours are not unique to the Museum of Childhood, but according to museum staff, there are few other museums in Cape Town with these types of resources, especially those that specifically focus on childhood. The local uniqueness of these deliverables will hopefully contribute to their ability to reach a large audience.

### LIMITATIONS

We recognize that we are limited by our knowledge of the culture present in communities both within reach of the museum and the potential locations for the mobile exhibit. Throughout the seven weeks we were here, we gained knowledge of the area and the people within, but we are nowhere near being considered experts. We understood that we are not qualified to talk about what childhood looks like from different backgrounds, so we designed the booth and came up

with the general concept for what should be included within, but not the specific stories themselves. The museum will decide which stories from diverse backgrounds will be told by the mobile exhibit.

We also recognize that our surveying and design results may not be reflective of the thoughts and feelings of every individual residing in locations in or around Cape Town. We interviewed and surveyed a decent portion of children and adults, but the thoughts of these individuals do not necessarily reflect those of the entire community. Within our short time in Cape Town, we were unable to travel to neighboring cities and townships as we would have liked.

Our survey results were considered when coming up with designs for the mobile exhibit, however, they were not the deciding factor for what exactly the exhibit should include or look like. This is due to the relatively small sample size of responses. The small sample size affects the reliability of the survey's results, as it creates a higher chance of bias. To collect this data we kindly approached visitors, explaining who we were and what we were doing. We then presented them with a QR code to fill out the survey. By approaching the visitors, we had a much higher chance of getting responses than if we were to have simply just posted the QR code on the exit door or next to the sign-in book. Unfortunately, there were only a few families or groups of people who visited the museum, and many of the guardians brought the younger children daily, so there was not a wide variety of responses. To expand our range of responses beyond the few visitors, the survey link was also posted on the Museum of Childhood's social media pages.

Another limitation was that the interviews conducted for gathering information on the target population were with liaisons as opposed to direct members. For example, Benita Cornelius was a principal from a school who provided her thoughts on what would be successful and what the children may be interested in, but we did not speak with the children themselves. The same goes for the interviews with the Parent Centre. The three workers who were interviewed all work closely with mothers of the target population and were able to answer questions on their behalf. We did get some valuable information, as all three of the interviewees are mothers and were able to answer questions for themselves.

## RECOMMENDATIONS ON NEXT STEPS

Based on our findings and the status of the deliverable, ***we recommend that the following actions be taken to contribute towards the development of the mobile exhibit:***

- *Secure funding to support the development and construction of the story booths.* Included in the exhibit description and construction guide is a cost estimate for build materials, but additional costs will include hiring a contractor to follow through with the design process as well as hiring a graphic designer to put together the designs for the interior walls.
- *Determine whose childhood stories will be told in each booth.* This will involve identifying potential story themes, identifying subjects within the community willing to share their stories, performing interviews with each subject, and narrowing down the participant pool to contain a small number of diverse stories.
- *Collect the multimedia elements to support each story.* This will include finding photographs from the subject's childhood (or from people with similar childhood experiences), creating audio recordings of the subject's story, developing graphics to accompany the stories, and collecting the supporting background information to provide sufficient historical and geographic context to the story.

- *Contact and hire contractors and graphic designers to carry out the construction and interior design of the booths.* The blueprints provided within the construction guide should allow for a seamless transition of ideas.

If funding cannot be secured within a reasonable timeframe, it is also possible to ***create a pilot exhibit which utilizes the overall message and exhibit structure*** outlined in the exhibit description and construction guide. A similar experience to what the booth offers can be achieved through less expensive means if the interior of the booths are displayed as large posters. The “Tell Your Story” activity could then be located at a table at the center of these posters, keeping the interactive element intact. In this iteration, the exhibit loses the sense of complete immersion into the life of another, but still allows for the visitor to learn about and picture the lives of those whose childhood experiences differ from theirs.

There is also an opportunity for ***long term expansion of this exhibit***, given it is determined to be a useful resource for the museum after its implementation. The current model for the exhibit calls for three storytelling booths. If the museum decides that the project has been successful though, the exhibit could easily be expanded to contain more booths, and therefore more examples of diverse childhood stories.

In order to utilize the virtual tour to its full potential, ***we recommend the software is implemented in the following areas:***

- The museum website
- The museum’s social media platforms (Instagram, Facebook, etc.)
- In the mobile exhibit (and future mobile exhibits and outreach programs) through the use of QR codes

## 6 REFERENCES

- Badger, J., & Harker, R. J. W. (2016). The impact of a museum traveling exhibition on middle school teachers and students from rural, low-income homes. *International Review of Education*, 62(3), 355–374. <https://doi.org/10.1007/s11159-016-9566-5>
- Barge, Pulschen, A. A., Emygdio, A. P. M., Congreve, C., Kishimoto, D. E., Bendia, A. G., de Morais M. Teles, A., DeMarines, J., & Stoupin, D. (2013). Life, the Universe, and Everything: An Education Outreach Proposal to Build a Traveling Astrobiology Exhibit. *Astrobiology*, 13(3), 33–308. <https://doi.org/10.1089/ast.2012.0834>
- Calcagni, A., Dollins, C., Pham, B., & Krigsman, J. (2021). *Designing an Interactive Smiley Face Cart as a Family-Friendly Mobile Exhibit*. Worcester Polytechnic Institute.
- Cape Town the Segregated city*. (n.d.). South African History Online. <https://www.sahistory.org.za/article/cape-town-segregated-city>
- Chamberlain, C. (2010). Interpreting Native American History at Public History Institutions: The Louisiana State Museum's New Traveling Exhibit as a Case Study. *Native South* 3, 125-132. doi:10.1353/nso.2010.0008.
- Cochrane, A. (2014). Interviews. In K. Ward (Ed.). *Researching the City* (pp.38-53). ISBN 13: 978-1-4462-0210-4.
- Das, J., Singh, A., & Yi Chang, A. (2022). Test scores and educational opportunities: Panel evidence from five low- and middle-income countries. *Journal of Public Economics*, 206, 104570. <https://doi.org/10.1016/j.jpubeco.2021.104570>
- Department of Statistics. (2011). Improving Lives Through Data Ecosystems. *Statistics South Africa*. [https://www.statssa.gov.za/?page\\_id=4286&id=331](https://www.statssa.gov.za/?page_id=4286&id=331)
- Goal 4 | department of economic and social affairs. (n.d.). Retrieved 4 October 2022, from <https://sdgs.un.org/goals/goal4>
- Goddu, M. K., Lombrozo, T., & Gopnik, A. (2020). Transformations and Transfer: Preschool Children Understand Abstract Relations and Reason Analogically in a Causal Task. *Child Development*, 91(6), 1898–1915. <https://doi.org/10.1111/cdev.13412>
- Google Maps, 2022. *Cape Town Museum of Childhood*. Google Maps [online] Available through: <https://www.google.com/maps/@-33.9557455,18.4859809,3a,75y,82.97h,86.92t/data=!3m6!1e1!3m4!1sq3UWC4bAPONBFvWKMNyOjQ!2e0!7i16384!8i8192>.
- Heywood, M. (2021). *World inequality report shows global wealth disparity has reached record levels*. Daily Maverick.
- Home. (n.d.). Museum-of-Childhood. <https://www.museumofchildhood.org.za>
- Lemanski, C. (2006). Residential responses to fear (of crime plus) in two Cape Town suburbs: Implications for the post-apartheid city. *Journal of International Development*, 18(6), 787–802. <https://doi.org/10.1002/jid.1314>
- Marcus, M., Haden, C. A., & Uttal, D. H. (2017). STEM Learning and Transfer in a Children's Museum and Beyond. *Merrill-Palmer Quarterly*, 63(2), 155–180. <https://doi.org/10.13110/merrpalmquar1982.63.2.0155>
- Museum of Childhood to launch. (2015). *Bolander (Strand-Somerset West, South Africa)*, 12. Access World News.
- Penny, P., Marco, B., Rafael, M., & Martin, K. (2002). Texture and memory—The urbanism of District Six. Cape Technikon.
- Pretorius, J., Petersen, C. A. L., & Pedro, A. (2021). The socio-ecology of childcare in



- Apartheid South Africa: Retrospective experiences of a sample of caregivers. *Journal of Psychology in Africa*, 31(1), 98–101. <https://doi.org/10.1080/14330237.2020.1871248>
- Raynolds, L. B., Gillis, M. B., Matos, C., & Carpini, K. D. (2019). Equalizing Opportunities to Learn: A Collaborative Approach to Language and Literacy Development in Preschool. *YC Young Children*, 74(1), 22–29. *Statistics South Africa*. (2011). {Main Place | Statistics South Africa}. [https://www.statssa.gov.za/?page\\_id=4286](https://www.statssa.gov.za/?page_id=4286)
- The 17 goals | sustainable development*. (n.d.). Retrieved 6 October 2022, from <https://sdgs.un.org/goals>
- Viljoen, N. (2021). A safe space for the young and old. News24. <https://www.news24.com/news24/community-newspaper/peoples-post/a-safe-space-for-the-young-and-old-20210927>
- World read aloud day. (n.d.). Museum-of-Childhood. Retrieved 20 September 2022, from <https://www.museumofchildhood.org.za/world-read-aloud-day>

# APPENDIX A: PRE-EXISTING MUSEUM FEEDBACK SURVEY (REPRODUCED WITH PERMISSION)

**Your chance to WIN!**

You are welcome to keep this book and take it home, but we also want to remember you! So this is your chance to leave your mark! You can enter our competition by submitting this sheet, completed by you, in the box at the welcome desk. Every month one lucky visitor will receive a prize!

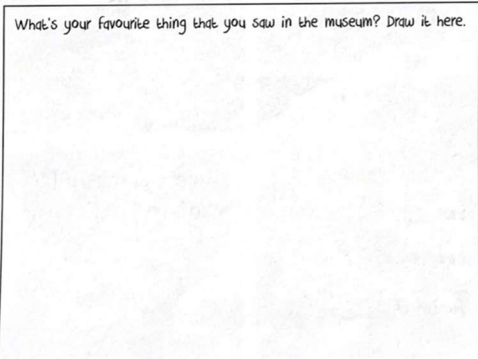
Your name and surname: \_\_\_\_\_

Email address: \_\_\_\_\_

Contact Number: \_\_\_\_\_

Do you want to join our mailing list, to find out about events, and news happening at the Cape Town Museum of Childhood? (please circle) YES NO

What's your favourite thing that you saw in the museum? Draw it here.



All about.....(Name)

I am.....years old.

My favourite things to do are...

I live with....

I am good at...

My favourite

Colour:.....

Food:.....

Game:.....

Animal:.....

When I grow up I want to....

## APPENDIX B: MUSEUM VISITOR HELPFUL FEEDBACK SURVEY

[https://docs.google.com/forms/d/1O0MyILh\\_bQsp2AYV5un3aJ3uZ9GGHDJYjHYYQbZlipI/edit](https://docs.google.com/forms/d/1O0MyILh_bQsp2AYV5un3aJ3uZ9GGHDJYjHYYQbZlipI/edit)



## APPENDIX C: LIST OF INTERVIEWEES

<b>Interviewee</b>	<b>Position/ Title</b>	<b>Date Interviewed</b>
Boniswa Gquma-Lisa		10/27/22
Claire Pearce	Program Assistant	10/27/22
Zara Nanji	Fundraising for CECD	10/27/22
Bomikazi Nomzanga		11/01/22
Eric Atmore	Director; Centre for Early Childhood Development	11/01/22
Navarne Weeder	Visitor Experience Officer	11/01/22
Bridget Kahts		11/03/22
Michaela Ashley-Cooper		11/03/22
Sarah Atmore	Project Manager	11/03/22
Alice	Parent Center Employee	11/08/22
Babalwa	Parent Center Employee	11/08/22
Lucy	Parent Center Employee	11/08/22
Margaux Bergman	Librarian; Pinewoods Public Library	11/14/22
Benita Cornelius	Principal; Christian David Moravian School	11/28/22

## APPENDIX D: PARENT CENTRE INTERVIEW QUESTIONS

1. Can you provide us with some background on your role in the Parent Centre and the Parent Centre Program as a whole?
2. Do you have children of your own? If yes, how many children and what are their ages?
3. From what you have seen, what is the biggest problem that children are facing today?
4. What is the most important message to show children in disadvantaged communities throughout Cape Town?
5. What is the most important lesson for children in your community? What is the most important lesson for parents in your community?
6. Any other thoughts or ideas?

## APPENDIX E: LIBRARIAN INTERVIEW QUESTIONS

1. Have you heard of the Cape Town Museum of Childhood? Have you ever visited?
2. Have you ever seen or visited a mobile museum exhibit, or anything similar? How was that experience?
3. Is a mobile exhibit something that, in your experience, libraries would potentially house?
4. What would be the ideal amount of time you expect visitors to stop and interact with an exhibit?
5. Should the exhibit be staffed or unstaffed?
6. Do you think the library patrons would benefit from having a mobile museum platform here?
7. Any other thoughts or ideas?



## APPENDIX F: SCHOOL PRINCIPAL INTERVIEW QUESTIONS

1. Can you tell us a little about your background and experience?
2. What are the most pressing issues you see facing the children at your school?
3. What is the most important message the children of Cape Town and South Africa need to hear?
4. What is your experience with museum visits and outreach programs in your school?
5. What types of activities and “exhibits” keep the kids at your school engaged?
6. What types of stories would be most effective at presenting themes of childhood differences within the story without making the story about childhood differences
7. Any other thoughts or ideas?

## APPENDIX G: MUSEUM STAFF INTERVIEW QUESTIONS

*Interviewing staff members at the Museum of Childhood to receive feedback and ideas on the approach to the mobile exhibit with the purpose of narrowing down ideas for the exhibit.*

1. How would you define the message of the museum?
2. What do you think is the most important thing that CTMOC can do for children in South Africa?
3. Which of the exhibits is your personal favorite and why?
4. Which of these ideas are your favorite/ do you think would be the best fit for a mobile exhibit: poster, interactive table, guided arts and crafts activity? Should we combine multiple of these or is there a different set up that you think could work?
5. What age range do you think the exhibit should focus on? Should we try to connect more with the 7-10 age range or younger/older?
6. FOR ANYONE WHO WAS AROUND FOR MUSEUM'S DEVELOPMENT: Can you describe what the exhibit development process looked like for CTMOC?
7. Do you think the mobile exhibit should be designed to be staffed or self-operated? What do you foresee as pros and cons of either one?
8. How long would you foresee the exhibit being able to keep visitors engaged and entertained? Do you picture the exhibit taking up a quick five minutes or providing a half an hour worth of information and entertainment?
9. In your opinion what would an ideal amount of time be for the exhibit to stay in one place? Should it be a day activity/something that can be taken into a classroom or is it something that will be there for a week or longer?
10. Any other thoughts or ideas?

# APPENDIX H: DESIGNER TEMPLATE EXAMPLE PAGES (REPRODUCED WITH PERMISSION)

S/6

→ generation - opportunity  
 → location - physical  
 → race →

Dear Designer of the Cape Town Museum of Childhood,

We created this template to help us understand your design approach, purpose and impact better. We will use it to structure our conversation during our upcoming meeting. Please feel free to have a look at it upfront to start reflecting and taking notes regarding your room design.

Please note the name of your room and describe its main message. The message should be ambitious, inspiring, and one sentence long.

**ROOM NAME:**  
 \*Example: Fantasy room

**MAIN MESSAGE:**  
 \*Example: There is magic in everything.  
 Celebrating the stages of childhood through generations

→ play  
 → childhood memories  
 → parental involvement

diverse childhood stories.  
 different experiences of childhood.  
 Through different generations and in different contexts.

Please describe the overall learning goals of the room. What you would like visiting children to learn? You may have 1 or more learning goals.

**LEARNING GOAL**  
 \*Example: I want the children to learn how to be open to the magic in the unexpected. This is why I want to help them see things from different perspectives, so that they have a richer, more joyful and open way of dealing with their lives and environments.

I want the children to learn how to be visitors aware of different childhood experiences ..... (attitude in context).

This is why I want to help them gain a better understanding of/appreciation for different people's childhood .....  
 (new skill or inspiration that helps them to fulfill the desired attitude), so that they can learn to be their most compassionate, empathetic, and accepting selves ..... (why may that be valuable for them/not in their lives yet).

Visualize how your ideas are connected into an overall room concept. Illustrate it like a story or adventure that the children will experience. Try to be as specific as you can.

What could go on the front?

- 3D or sensory pieces that kids can touch
- illustrations of ppl in story room? → headphones attached to back so you can listen to stories as you go
- famous or important (historically/socially) kids from each generation → show how kids can do cool and important things

boards w/ questions sorted into age stacky note w/ answers  
 favorite childhood memories, what does childhood mean to you

→ responses depend on area of exhibit, so this would have to be accompanied by something else to include more diverse group

# Construction Guide and Design Proposal for a Mobile Exhibit



Prepared for

The Cape Town Museum of Childhood

Date

16 December 2022

## INTRODUCTION

The purpose of this guide is to provide a complete overview of the work completed and ideas suggested by the team composed of Trevor Faber, Grace McCarthy, Patrick McKenna, and Grace Solod from the Worcester Polytechnic Institute. The document presents the proposed message, structure, and contents of the mobile exhibit, as well as CAD designs, blueprints, and cost estimates to make the transition of this exhibit from idea to reality as smooth as possible.

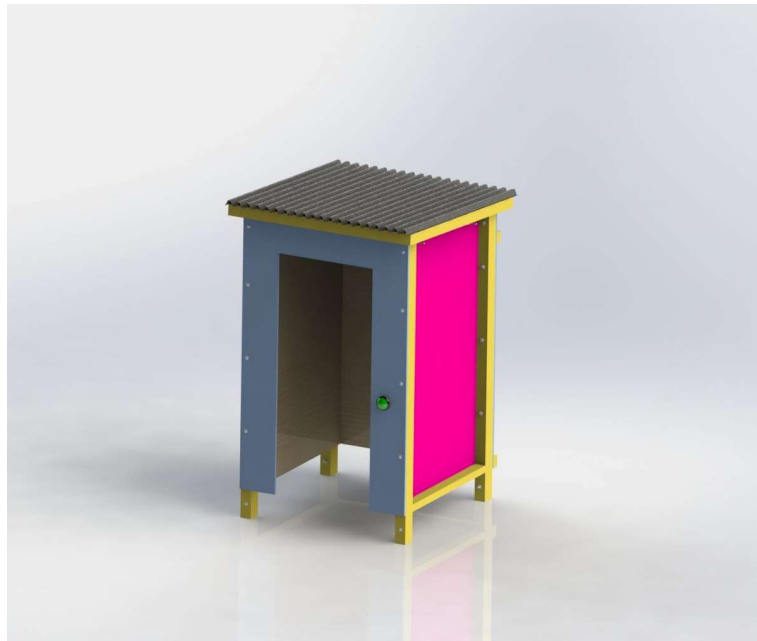
## MESSAGE

Through the analysis of survey data, assessment of interview responses, and multiple brainstorming sessions with various groups, we settled on the following message for the mobile exhibit: ***Celebrating diverse childhood stories***. The concept of diversity is broad and multi-faceted, and can address differences between people such as age, race, location, gender, and ability, among many other characteristics. Within this message, we developed the following three learning goals for the exhibit to address:

1. I want the visitors to learn how to be aware of different childhood experiences.
2. I want the visitors to learn how to be understanding of different childhood experiences.
3. I want the visitors to learn how to be empathetic towards others, especially children.

If successful in achieving its goals, the exhibit will act as a resource for people of all ages to become aware of and develop an understanding of the diverse range of childhood experiences. In the bigger picture, this level of understanding, when adopted by a majority of the population, can create a safer world for children.

## STRUCTURE



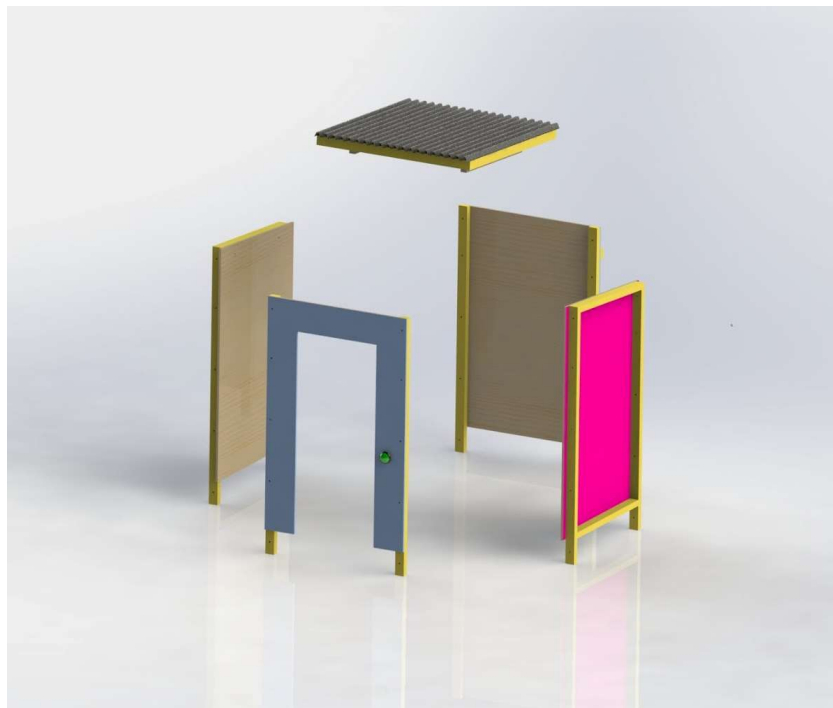
**Figure 10.** Immersive Story Booth CAD Rendering.

Our design plans for a total of four immersive booths. The booths were designed with the following design parameters in mind:

- Portable
- Easy to assemble
- Immersive
- Striking
- Structurally sound
- Ability to stand alone

To booth consist of the following to address these design parameters.

Each booth will be created out of five sub sections, a front panel, two side panel, rear panel and a roof. The panels and roof will be bolted together with 24 carriage bolts, washers and nuts at the joint of the structural frame of each panel. The bolts can be easily installed and uninstalled with minimal tools, a simple wrench and mallet will allow for the exhibit to be assembled anywhere. As each panel comes together the structural frame combines to create four posts to support the booth. This bolt design allows for a booth that can be transportable and structurally sound while still allowing each booth to be assembled by two people in under 20 minutes. The implementation of an impact drill would further reduce the assembly time. To visualize the construction process, we created the following video which shows exactly how each part comes together to form the final product: <https://youtu.be/2eYHhbzCuc8>.



**Figure 12.** Immersive story booth below out rendering, showcasing the five sections of the mobile exhibit

The five sections make the booths easy to transport, all sides of the booth can be carefully stacked and placed in the back of a bakkie (pick-up truck). Separating each panel with a blanket will ensure safe transportation without damaging any of the interior work or exterior paint. Besides the panels the only other aspects of the exhibit that need to be transported are the hardware, and any arts and crafts material associated with the fourth booth.

The five-section design also opens up the possibility to easily change the contents of the interior of the booths. Using a wallpaper method would allow for new interiors to be rolled onto each side individually.

The booth has been designed to account for a slight roof slant causing the entrance of the booth to have a height of 2.1 meters and the rear 2 meters. This slant serves the purpose of allowing any rainwater to run off the roof without pooling up. Each booth will have an open bottom to allow for ventilation and air circulation on hot days. The interior of the booth has basic dimensions of 1 meter wide, 1.2 meters deep and 2 meter high. These dimensions were derived from two factors, available building material and creating an experience that can be shared between a parent and their child. Plywood comes in 1.22-meter-wide sections so for the sake of simplicity the booth was designed to use the plywood sheets without the need of cutting down their width or using more than one sheet per side. These dimensions also allow for a space that can accommodate an adult and two small children, curating an immersive experience with enough room for it to be shared between an adult and a child.

To continue to encourage an immersive experience the interior walls of the exhibit have been designed to be uninterrupted, meaning the interior post of beams, allow for a seamless flow of ideas from wall to wall. The doorway to the booth will be covered by a curtain, making the booth its own room. A battery powered motion light mounted to the roof of the booth will light up to exhibit, further changing the atmosphere. It will be important for the light to be mounted directly above therefore not casting any shadows obstructing the interior. Speakers on either side wall of the exhibit, creating a surround sound feel. It is important that the speakers are also battery powered allowing the booths to operate without relying on access to electricity.

All the materials for the booths can be sourced locally from South African vendors, Somerset Timbers has all the wood available to build each booth. The frame of each panel is made from 50mm x 76mm structural pine, the roof incorporates 76mm x 114mm structural pine along with 36mm x 50mm structural pine runners. The walls are made from 18mm exterior plywood although it should be noted that the booth could be built out of slightly thinner plywood with the same blueprints to save money. The roof will be made from corrugated sheet metal.

To protect against weathering all structural wood should be treated to H2 standard. A further coat of clear polyurethane will be beneficial in further protecting the frame and any exterior paint. While moving the booths to a new spot the ground they are being placed on must be considered. If placed in dirt concrete footing will help protect the post against rot.

The final consideration is connecting the storytelling booths back to the museum of childhood. This can be done two ways, using the museum's color scheme and including a QR code for the virtual tour within the mobile exhibit.

## *BLUEPRINTS*

In an effort to make it as easy as possible for the museum to capitalize on the physical design of the Story Booth a series of blueprints have been developed. The blueprints start with a

full assembly view and then break down into each subassembly (each of the five sections) and then further breaks down into each individual part of each sub assembly. The table of parts on each assembly drawing allows the viewer to establish which parts correlate to the parts within each sub assembly.

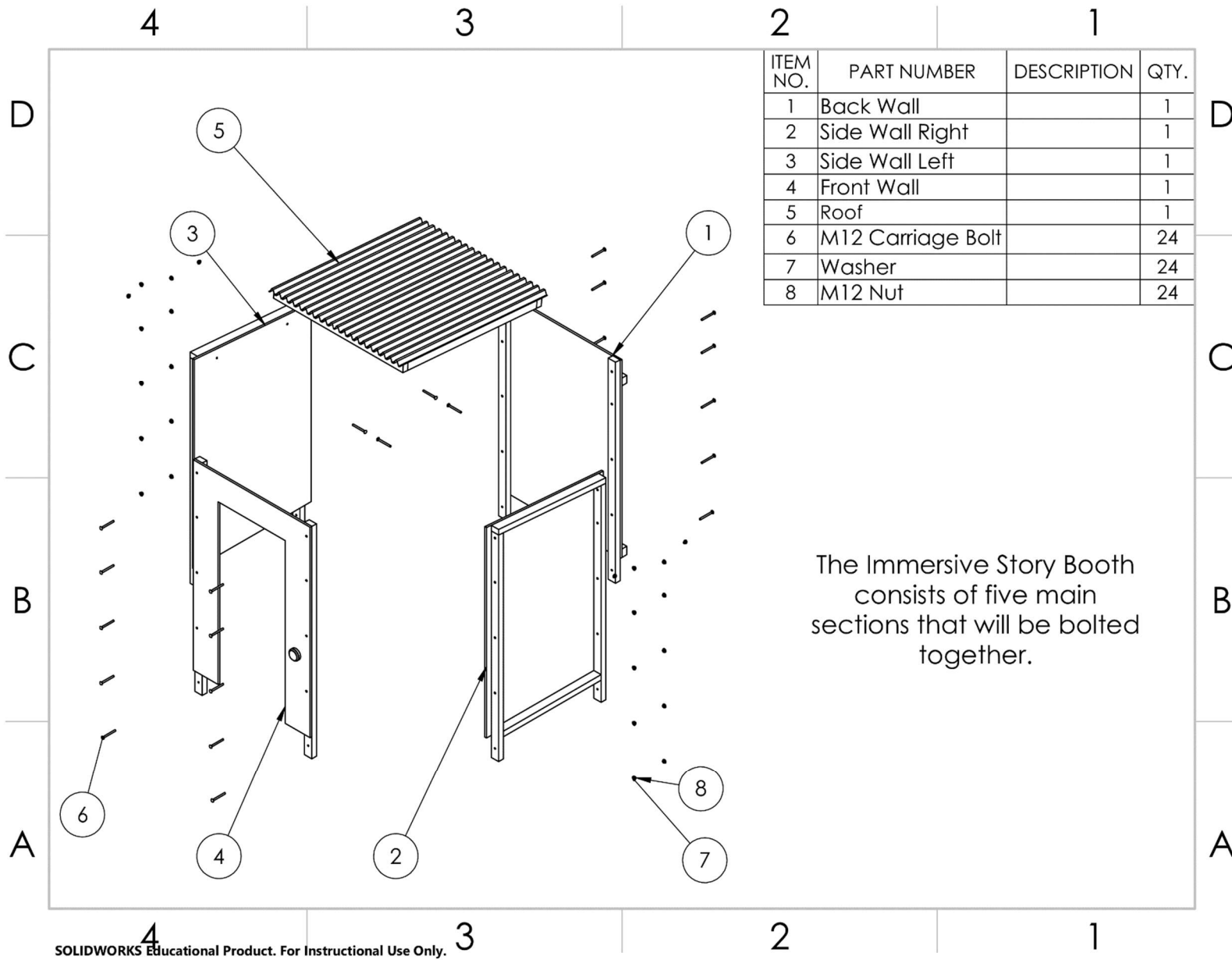
**Table 2.** Estimated Material Cost (wood cost were projected based on Somerset Timbers price catalog)

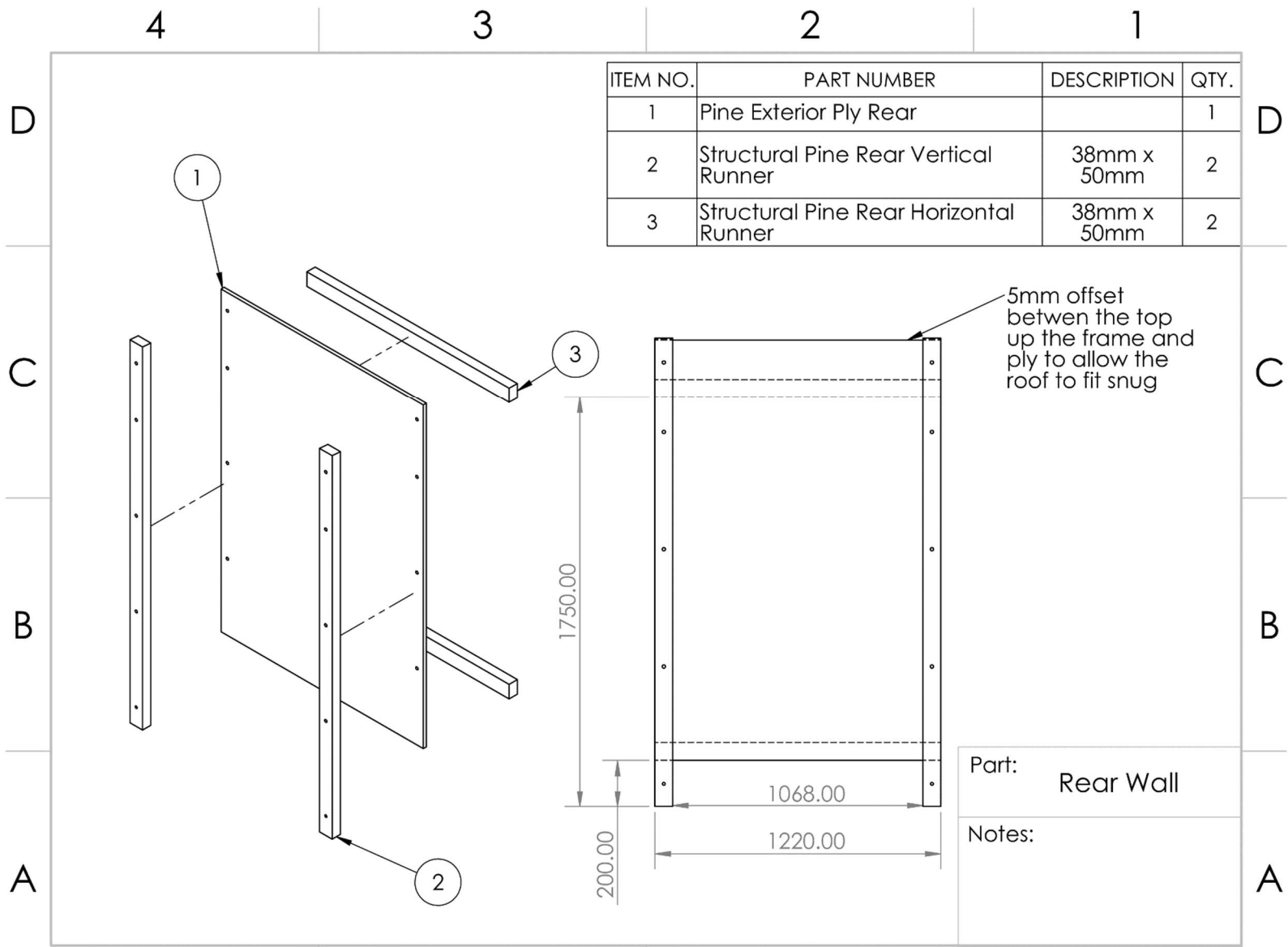
ITEM NO.	PART NUMBER	QTY.	Estimated Length of Material (meters)	Cost per Meter	Cost per Unit	Total Cost
1	Pine Exterior Ply Rear	1			931.99	931.99
2	Structural Pine Rear Vertical Runner	2	2.01	35.22	70.7922	141.5844
3	Structural Pine Rear Horizontal Runner	2	1.22	35.22	42.9684	85.9368
4	Pine Exterior Ply Side	2			931.99	1863.98
5	Structural Pine Side Vertical Front Runner	2	2.05	35.22	72.201	144.402
6	Structural Pine Side Vertical Rear Runner	2	2.01	35.22	70.7922	141.5844
7	Structural Pine Side Horizontal Top Runner	2	1.13	35.22	39.7986	79.5972
8	Structural Pine Side Horizontal Bottom Runner	2	1.02	35.22	35.9244	71.8488
10	Pine Exterior Ply Front	1			931.99	931.99
11	Structural Pine Front Runner	2	2.1	35.22	73.962	147.924
18	Structural Pine Roof Front Beam	2	1.35	35.22	47.547	95.094



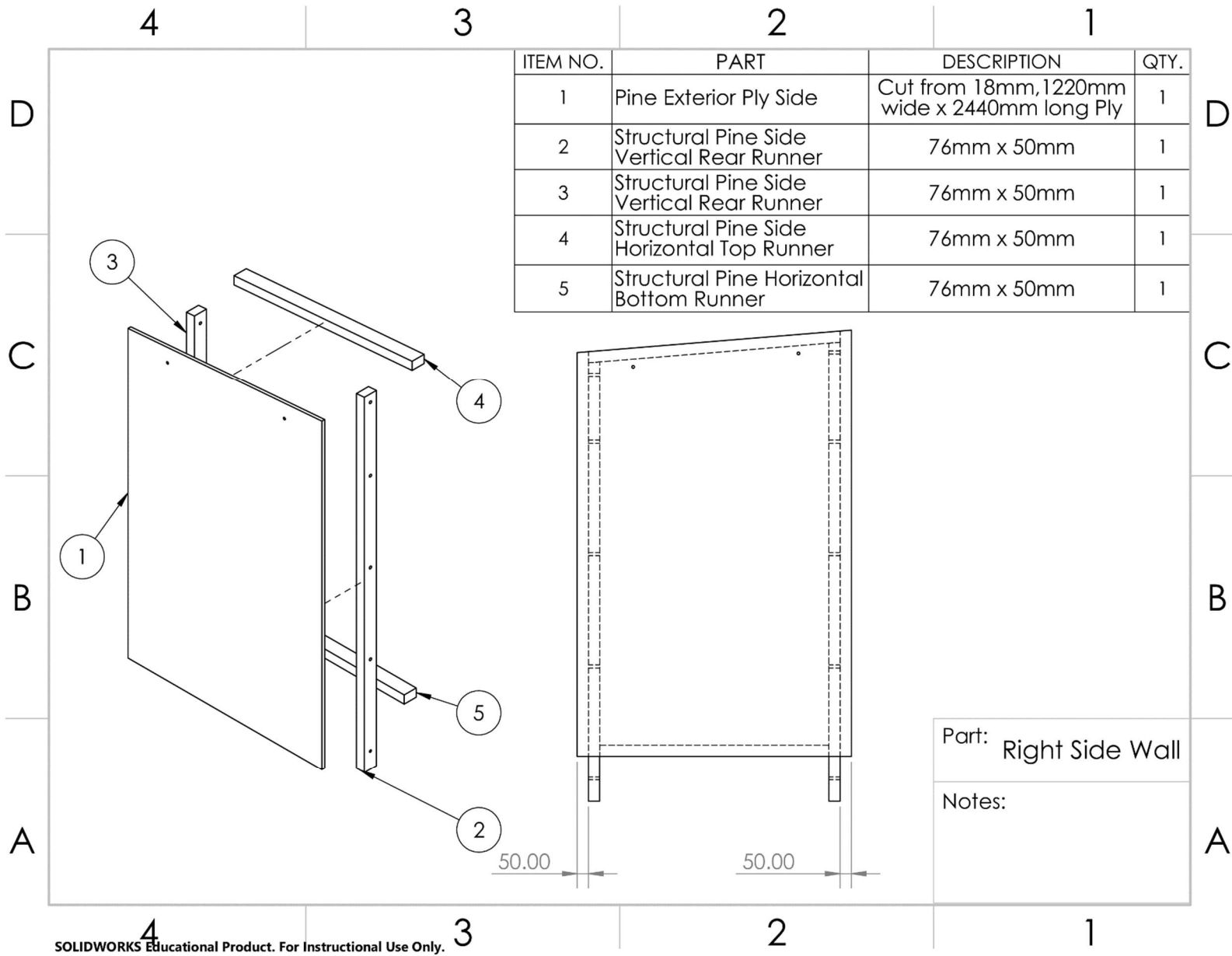
19	Structural Pine Roof Side Beam	2	1.35	35.22	47.547	95.094
20	Structural Pine Roof Attachment Runner	2	0.94	55	51.7	103.4
21	Structural Pine Roof Runner	5	1.25	35.22	44.025	220.125
22	Sheetmetal	2				500
23	M12 Carriage Bolt	24				500
24	Washer	24				0
25	M12 Nut	24				0
<b>Total</b>						
<b>R</b>						6054.5506



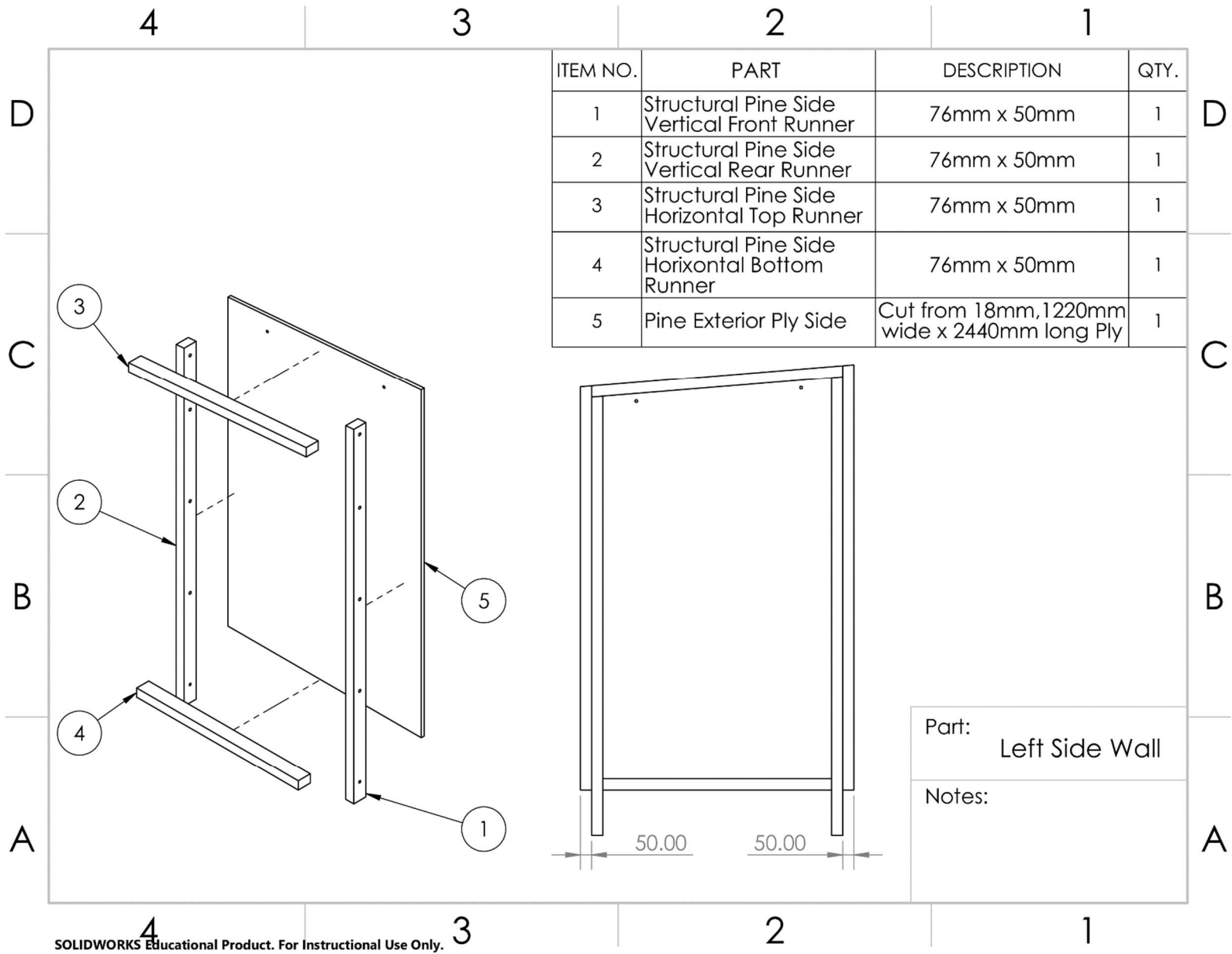




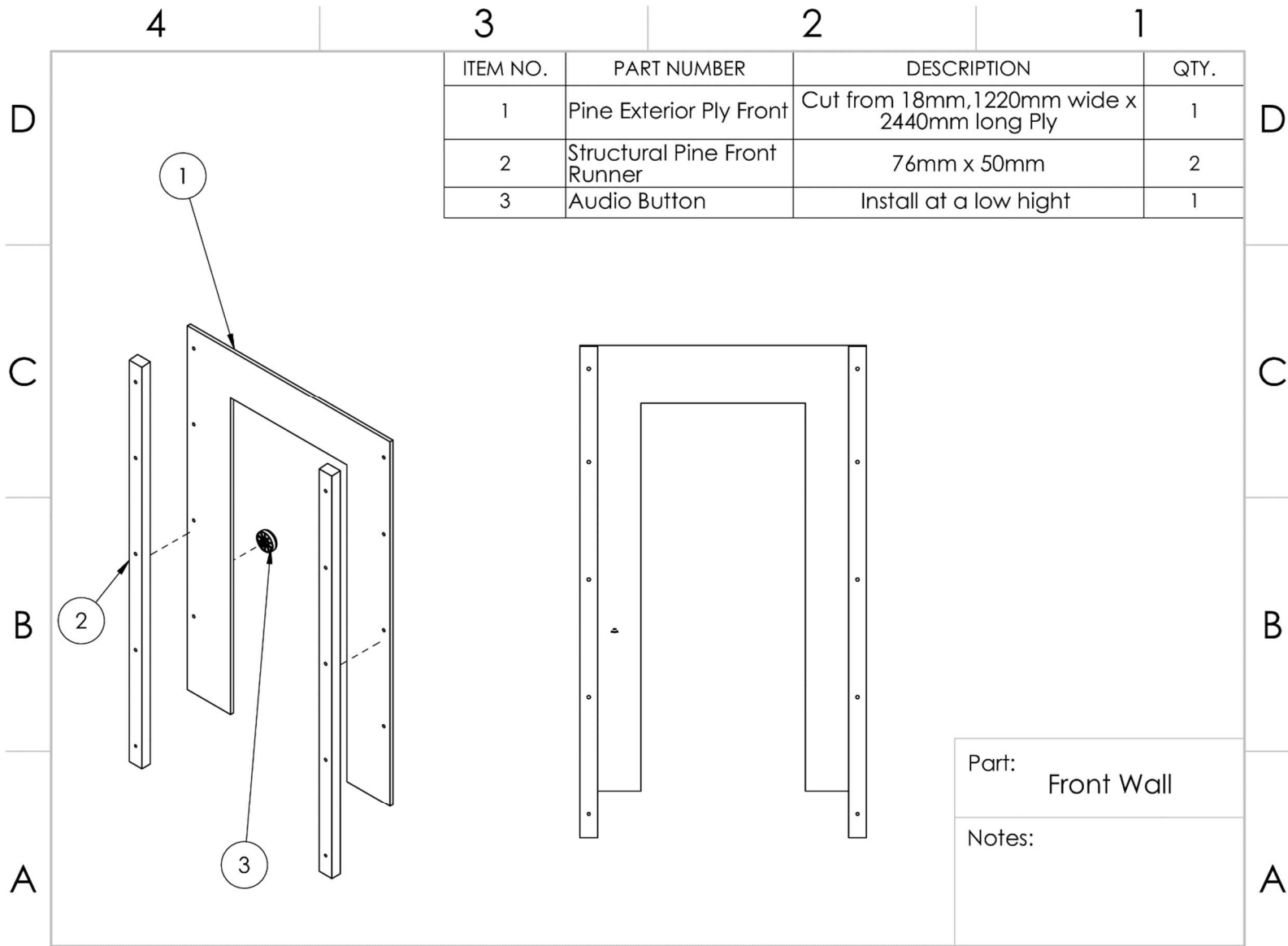
SOLIDWORKS Educational Product. For Instructional Use Only.



SOLIDWORKS Educational Product. For Instructional Use Only.



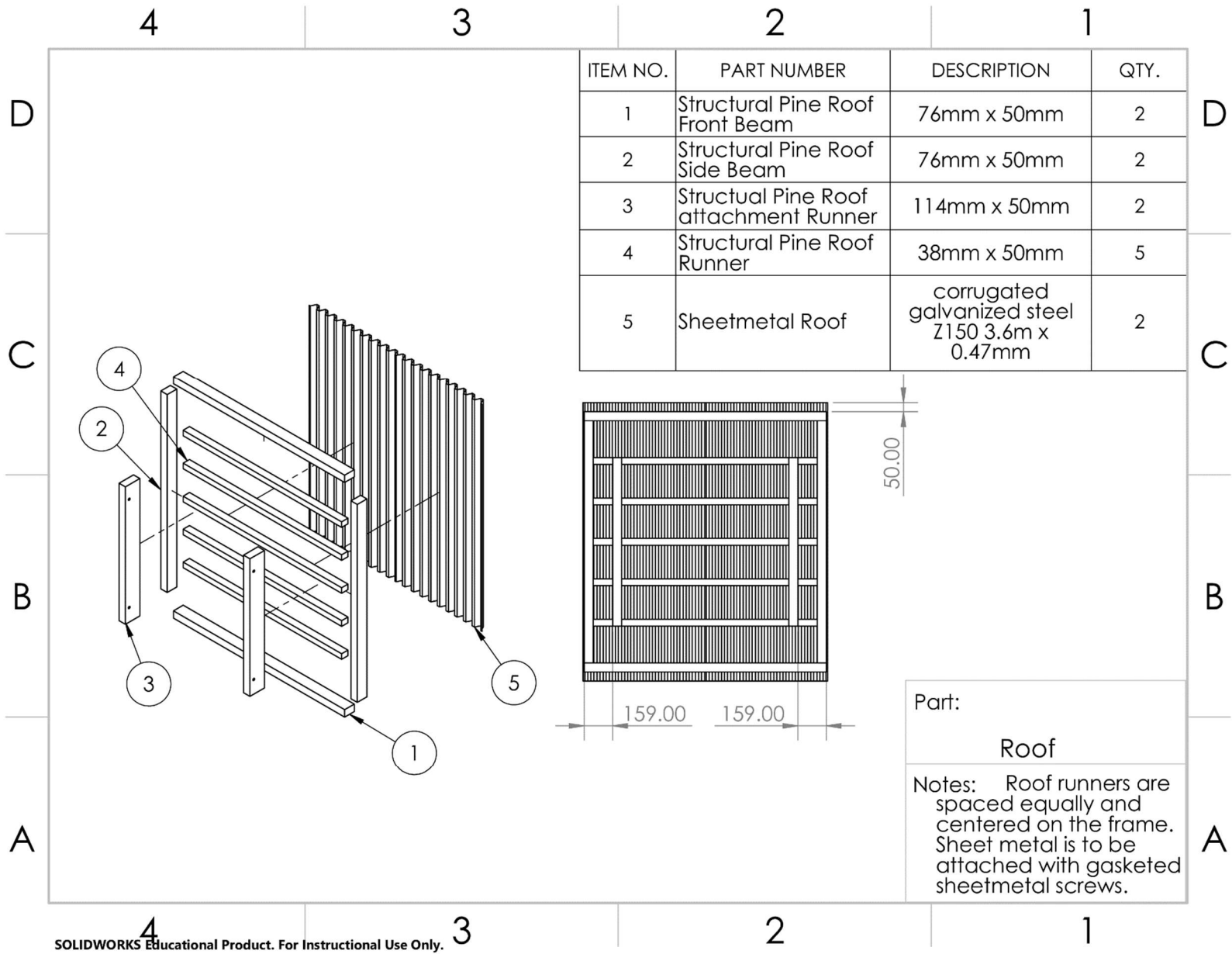
SOLIDWORKS Educational Product. For Instructional Use Only.



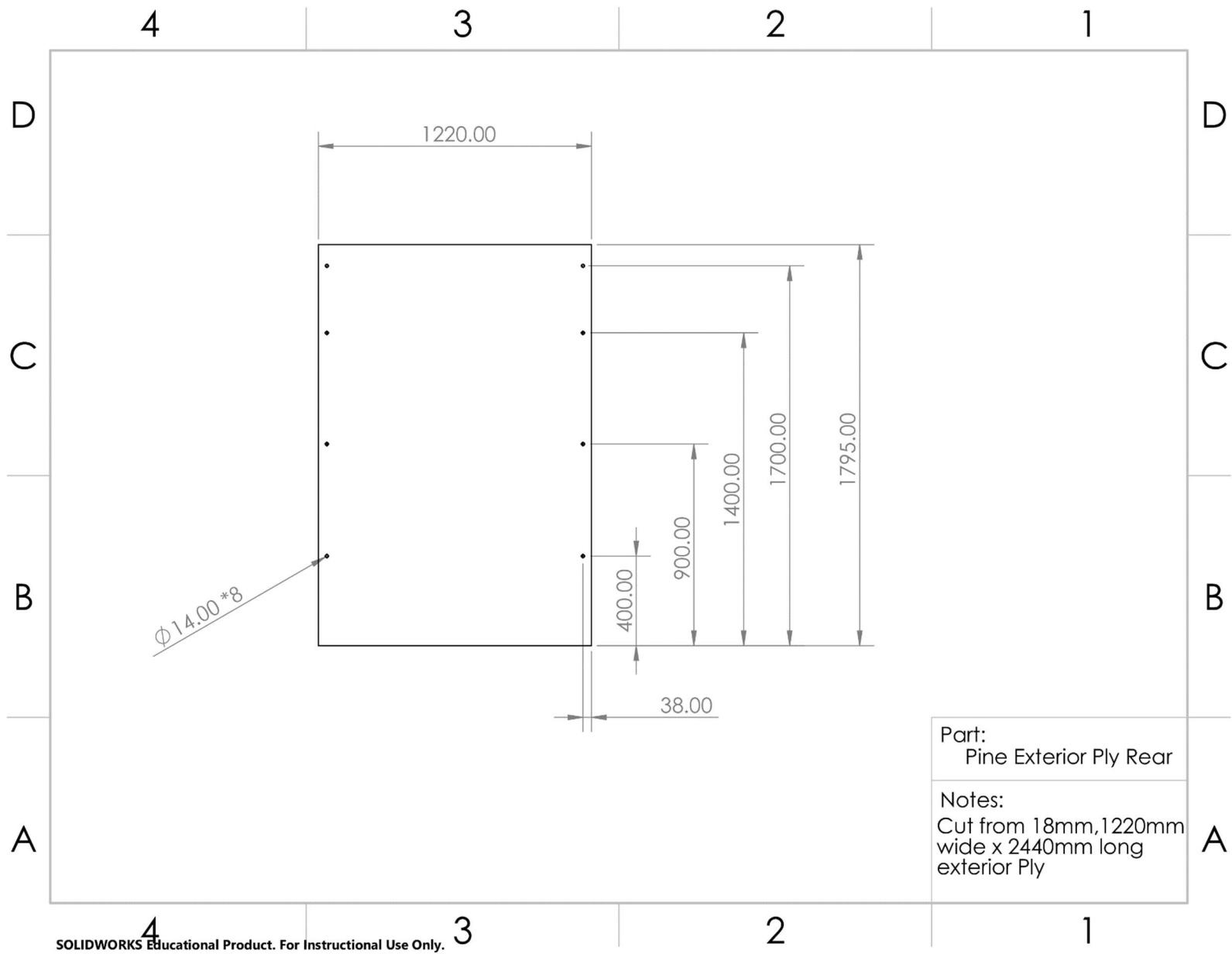
ITEM NO.	PART NUMBER	DESCRIPTION	QTY.
1	Pine Exterior Ply Front	Cut from 18mm, 1220mm wide x 2440mm long Ply	1
2	Structural Pine Front Runner	76mm x 50mm	2
3	Audio Button	Install at a low height	1

Part: Front Wall

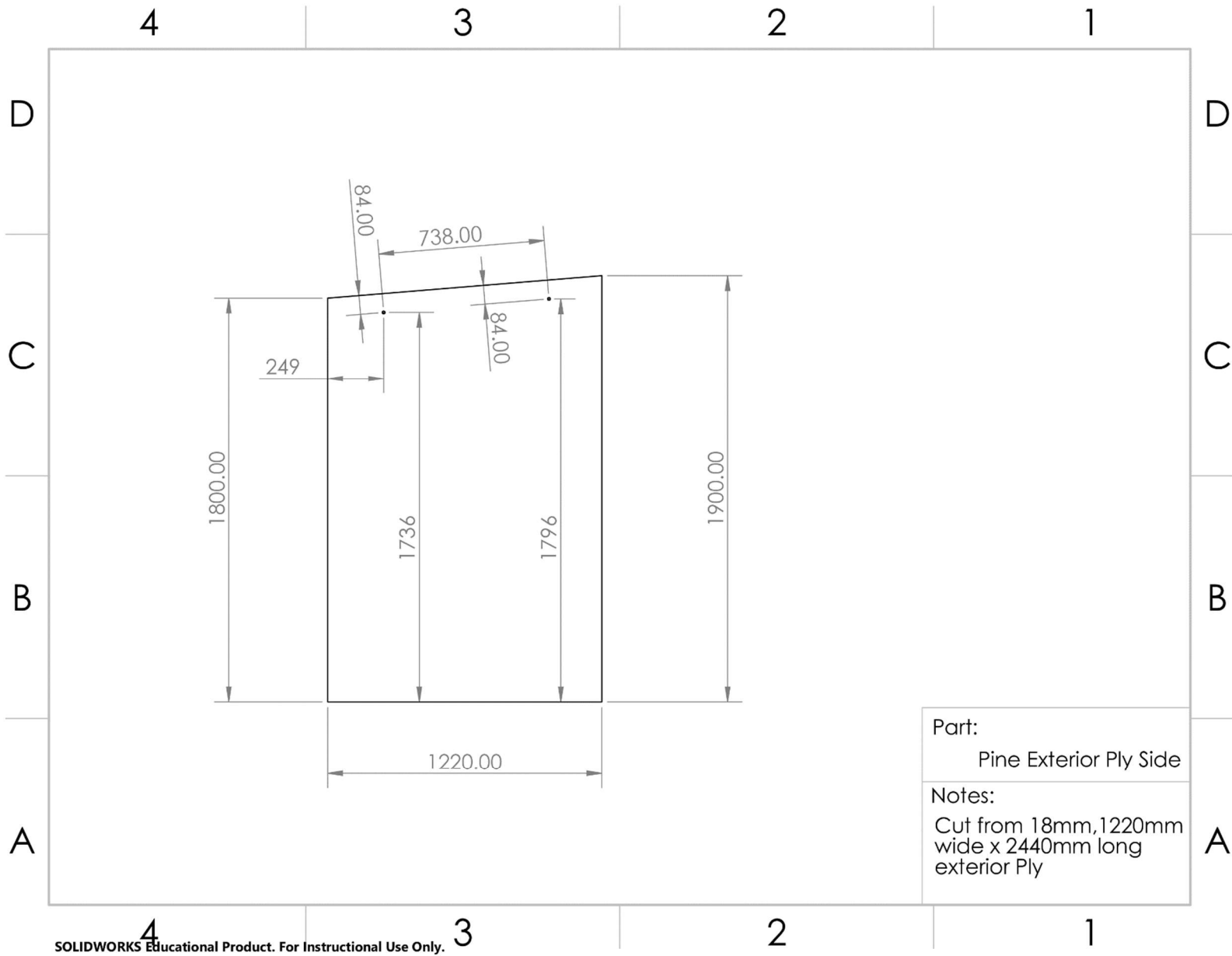
Notes:



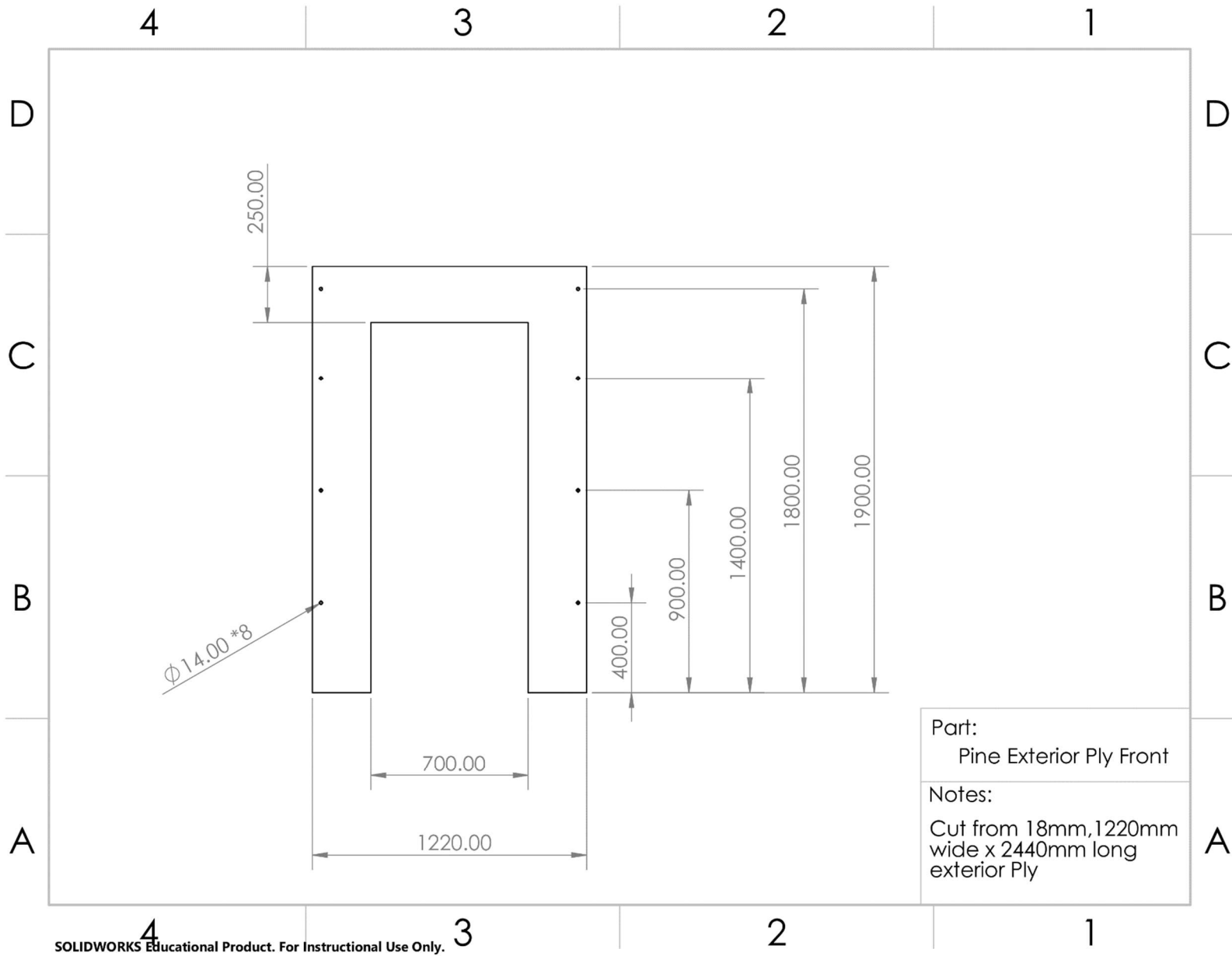


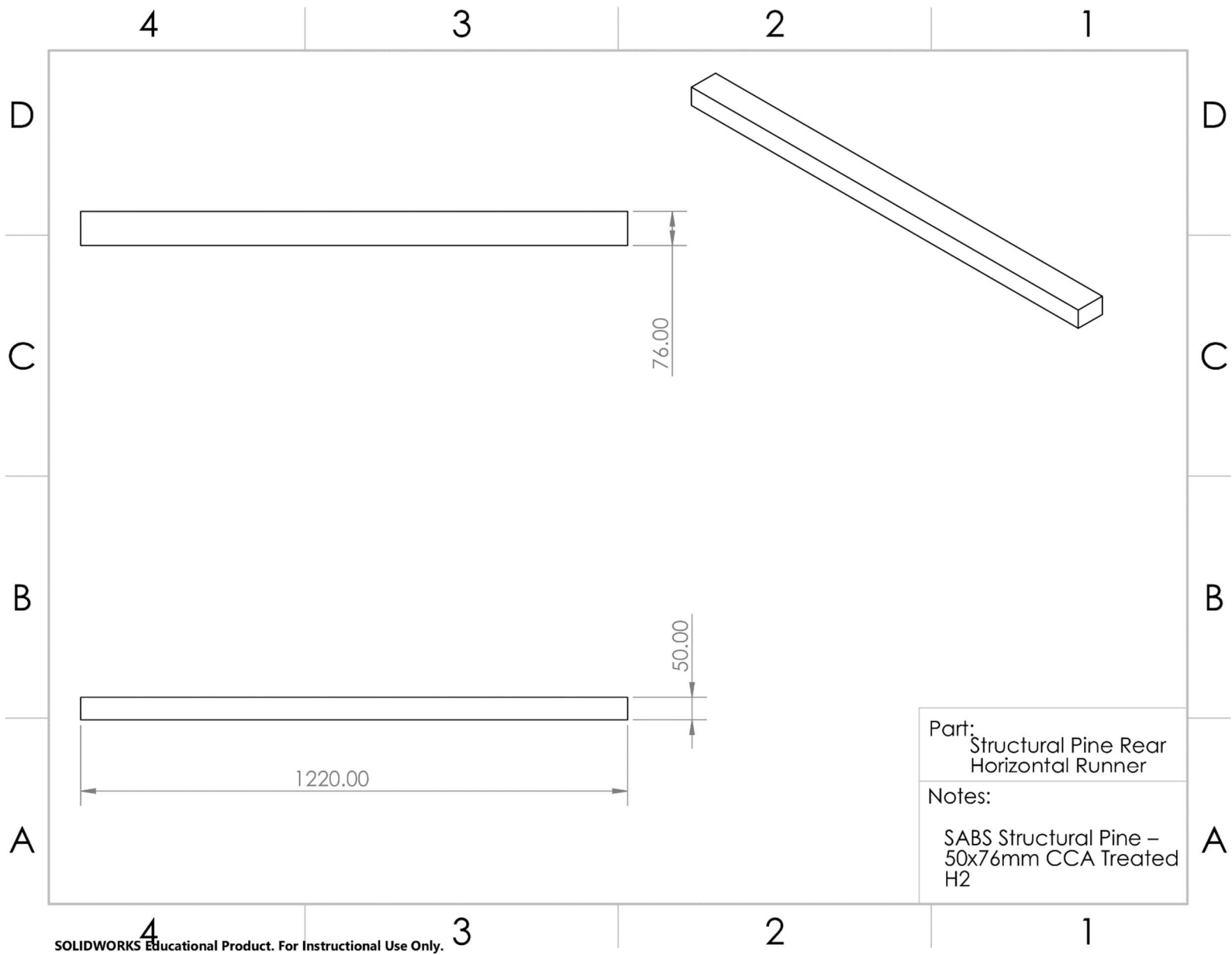


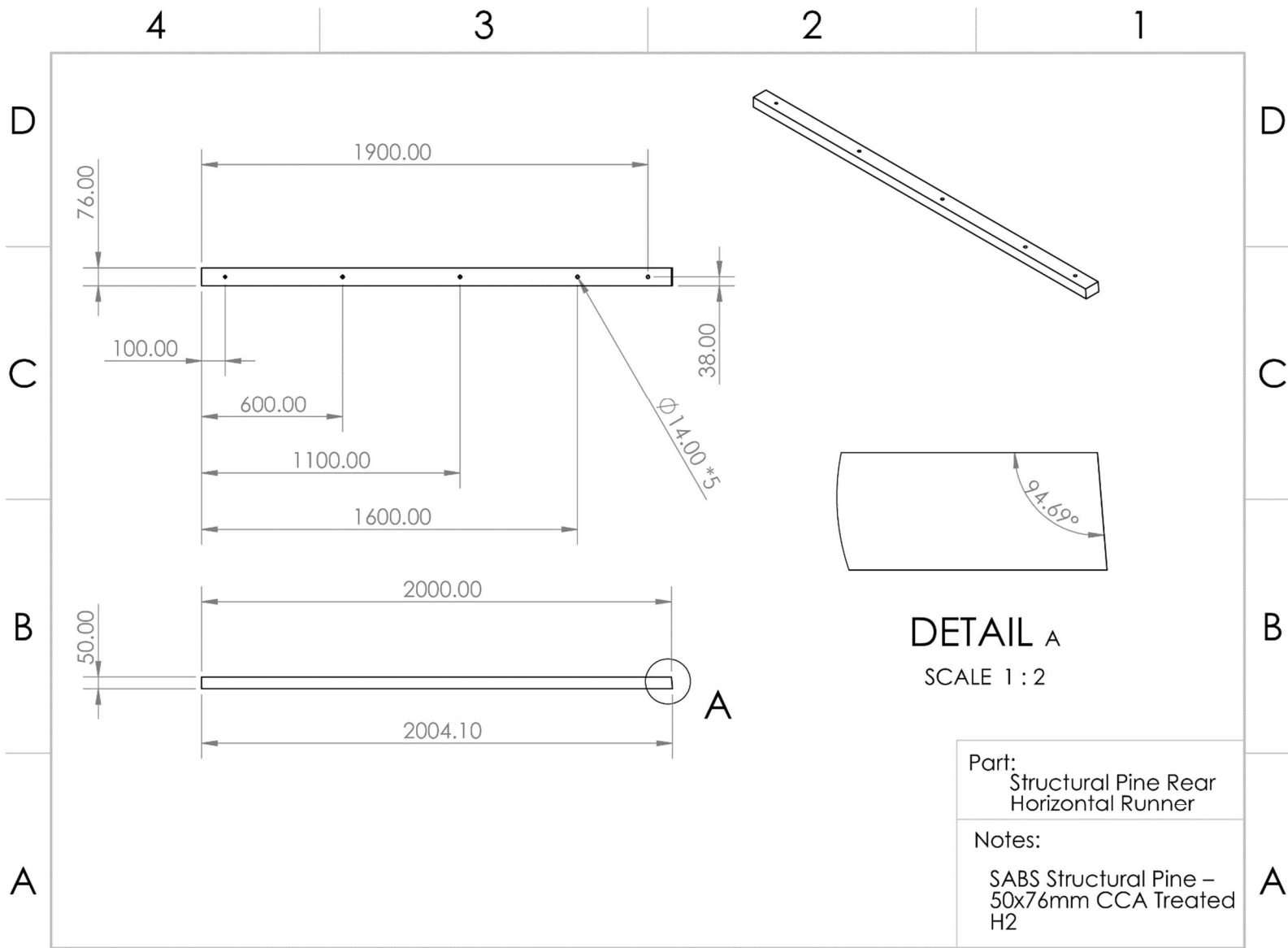
SOLIDWORKS Educational Product. For Instructional Use Only.



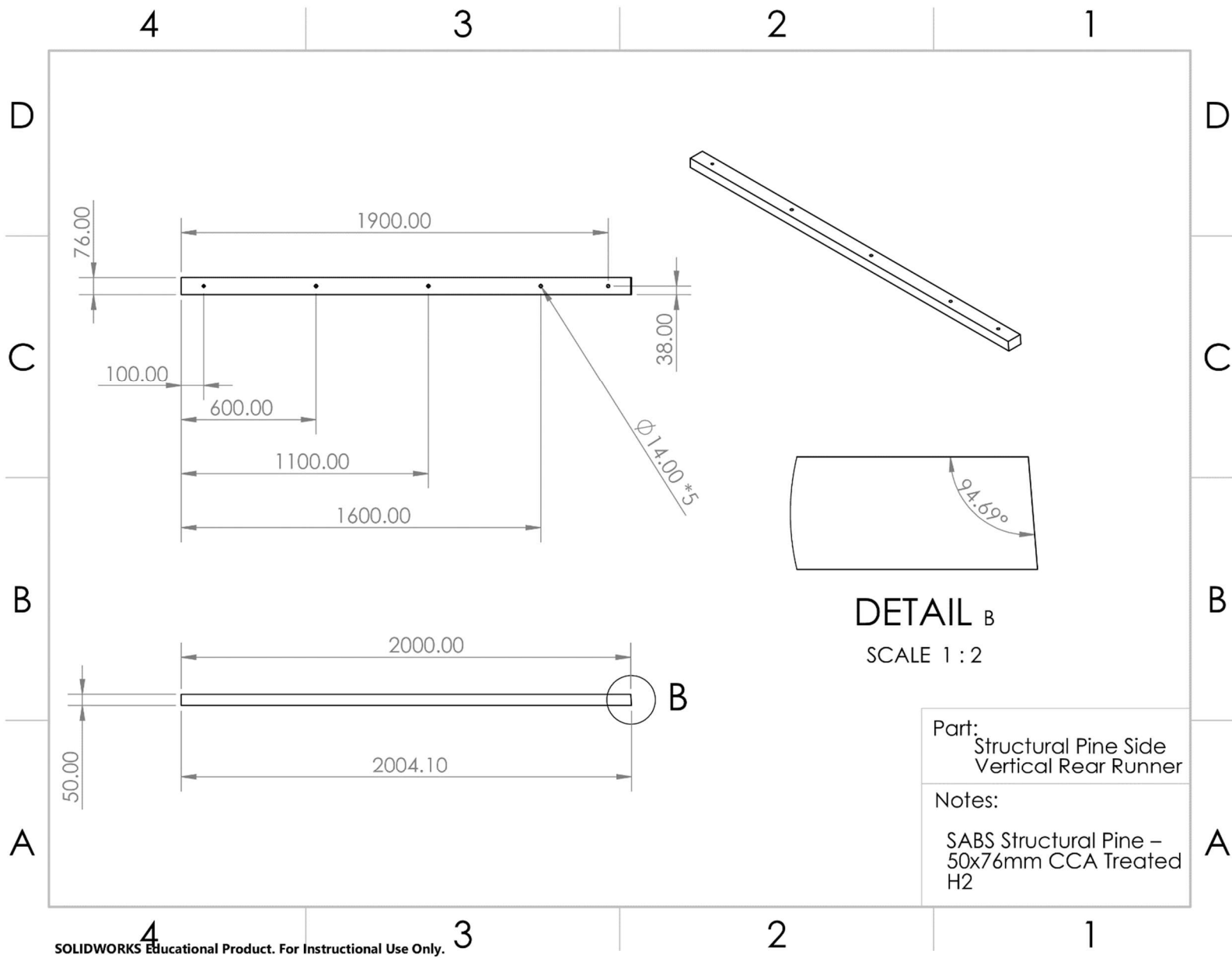
SOLIDWORKS Educational Product. For Instructional Use Only.

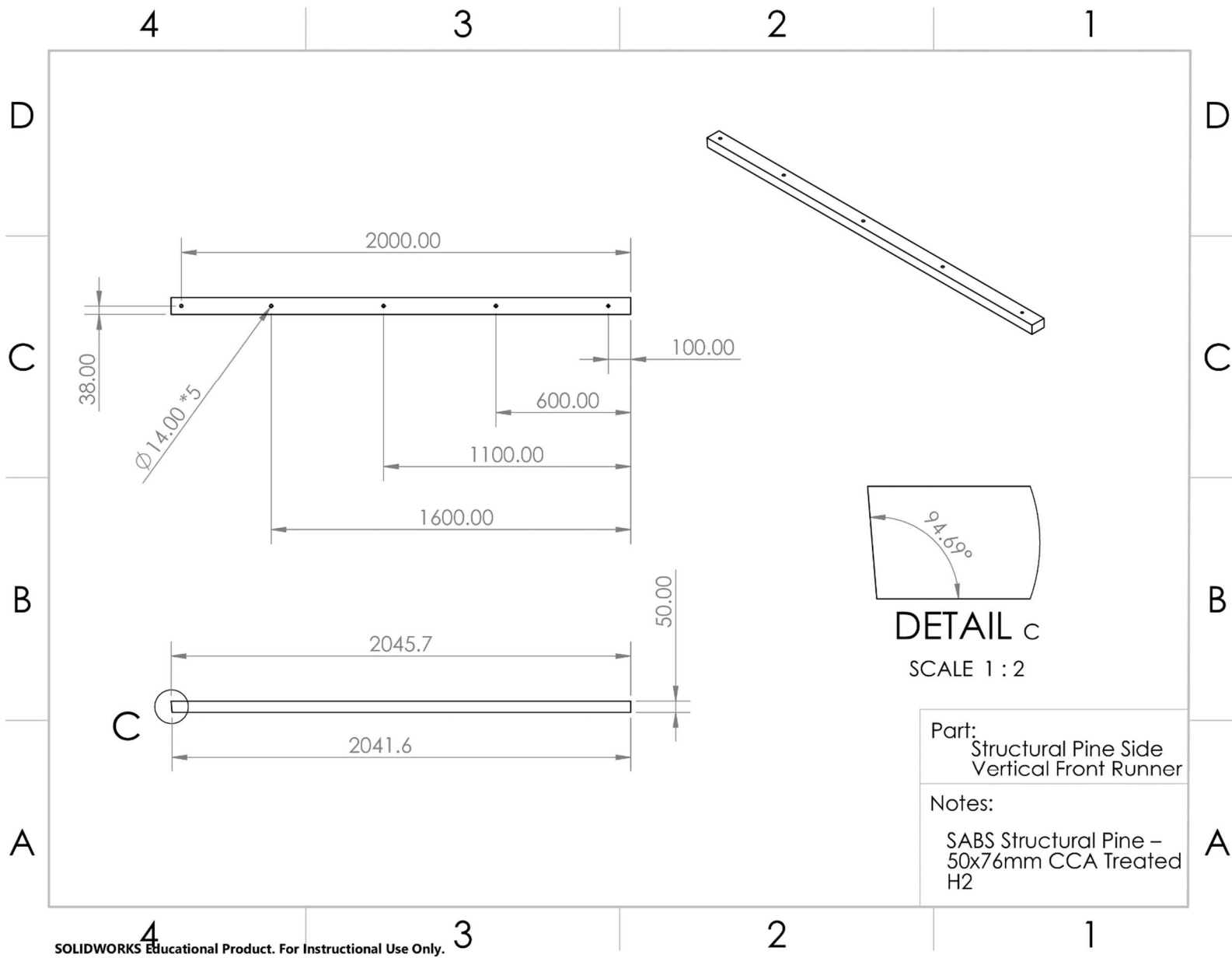




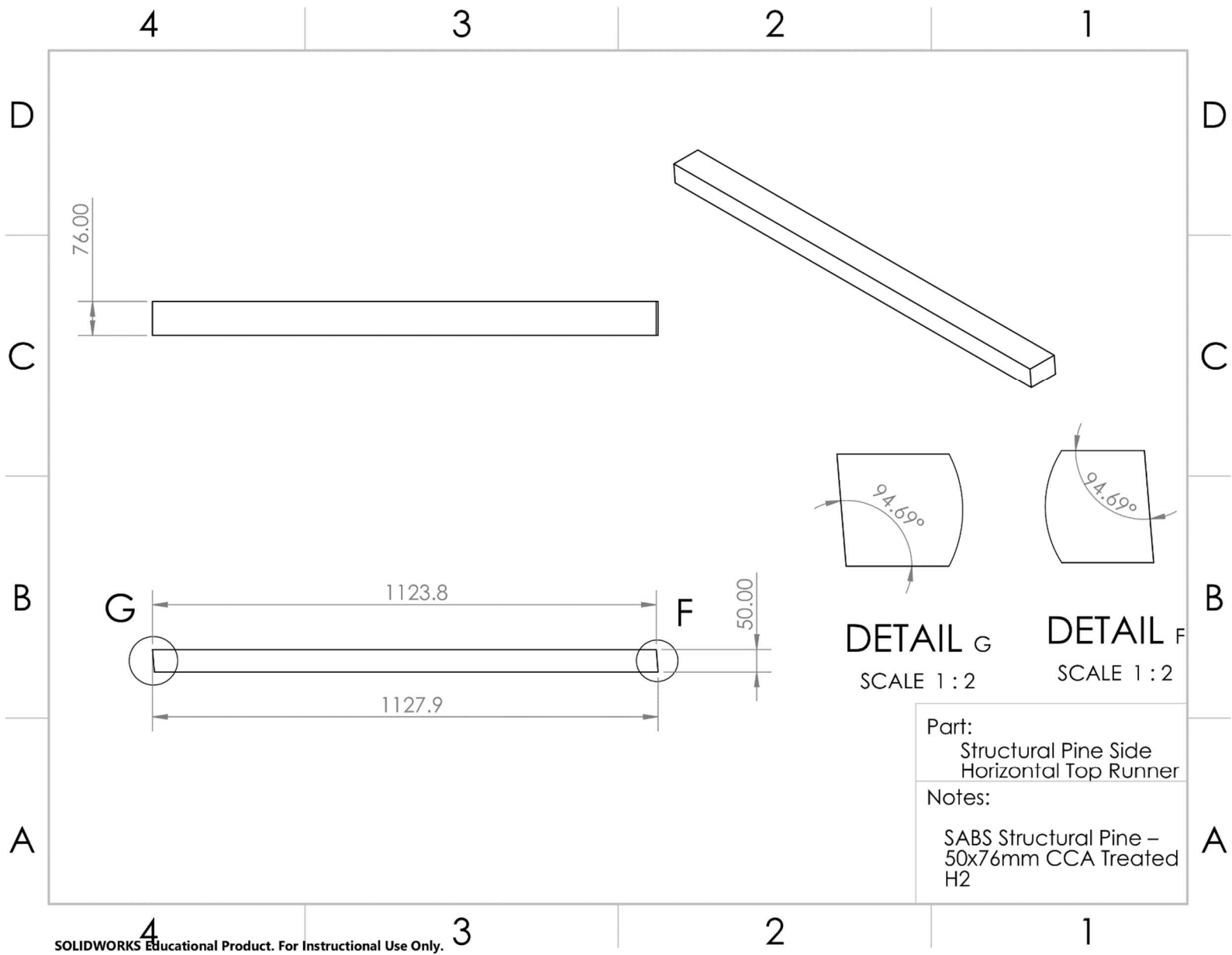


SOLIDWORKS Educational Product. For Instructional Use Only.



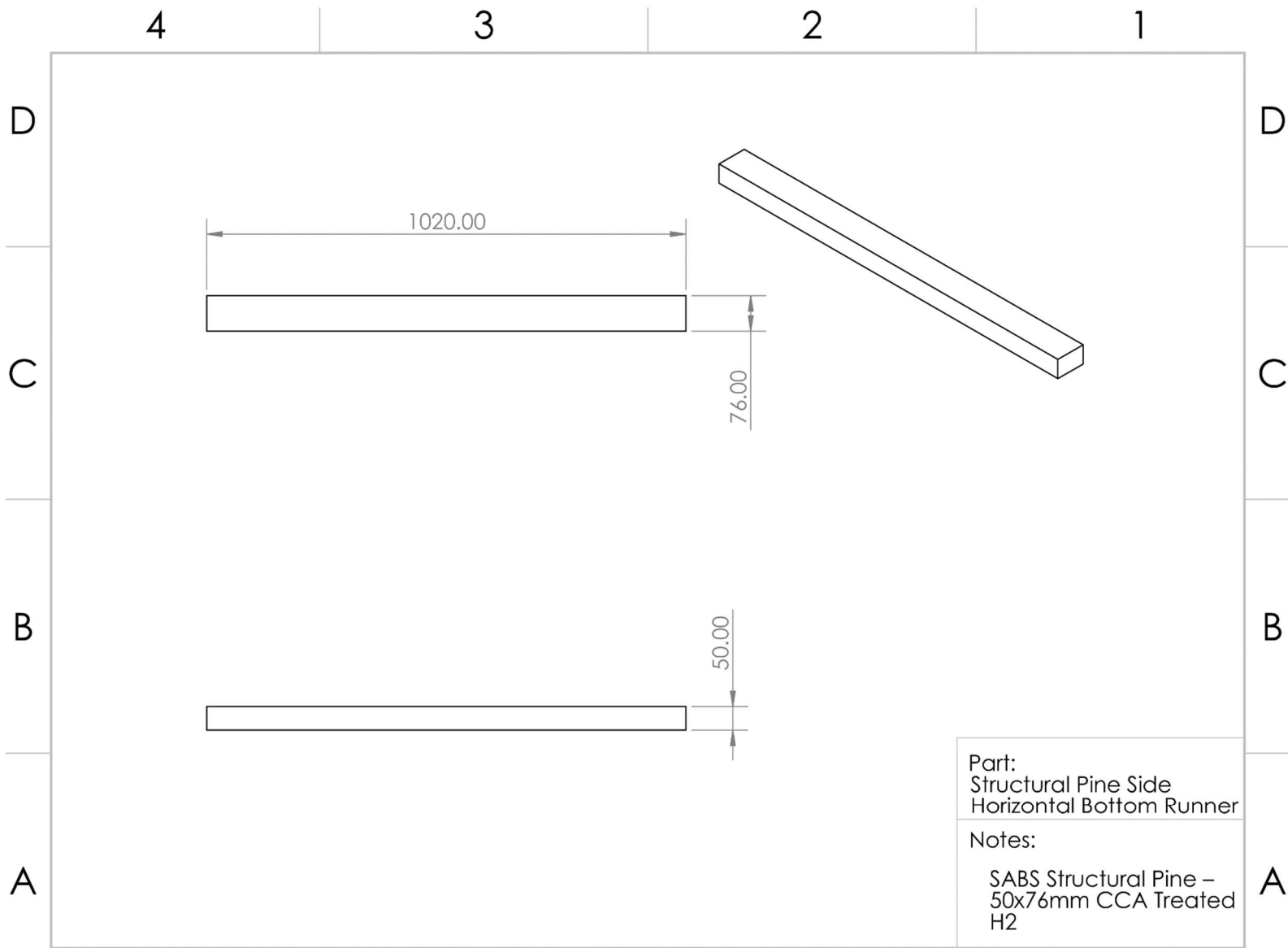


SOLIDWORKS Educational Product. For Instructional Use Only.

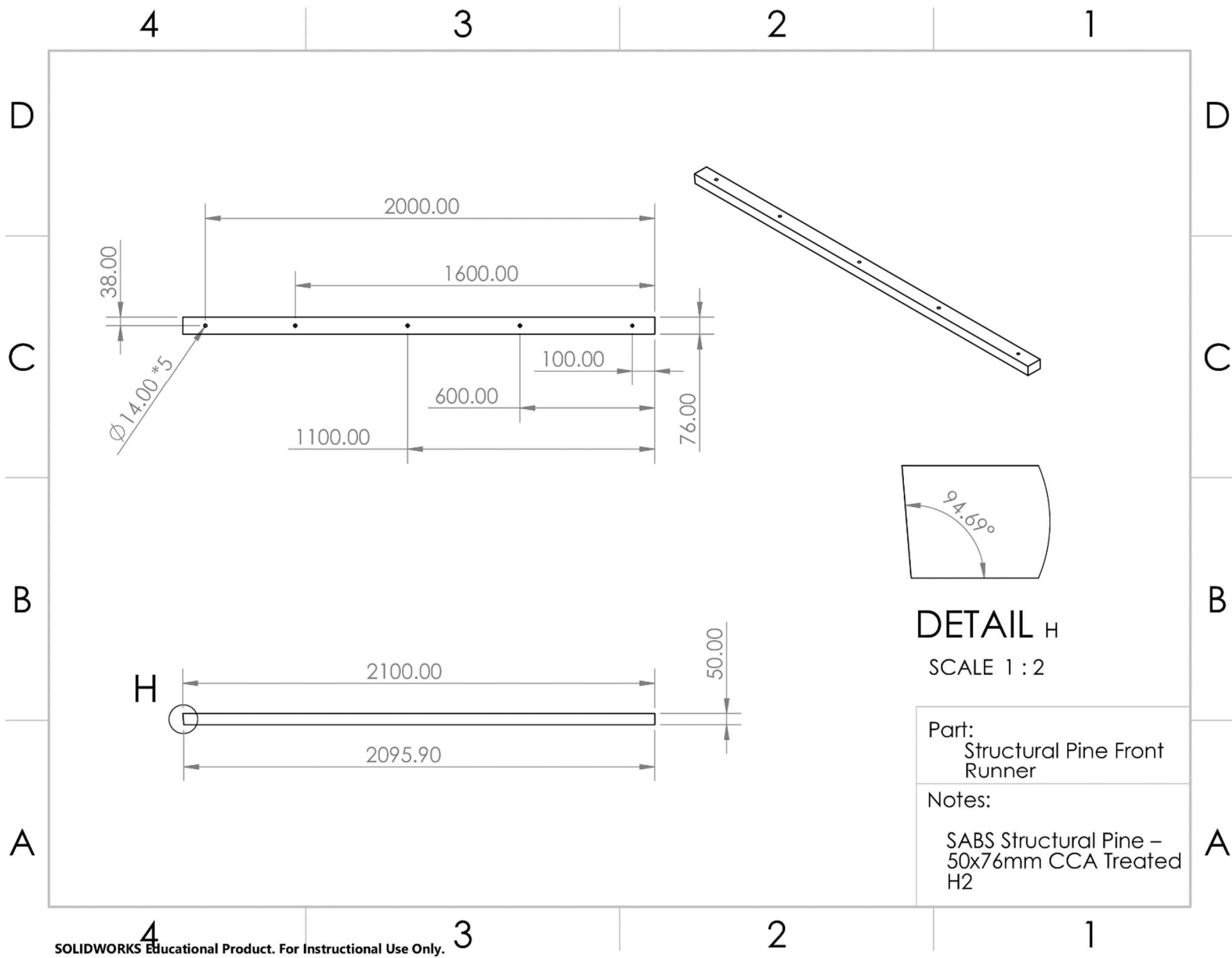


SOLIDWORKS Educational Product. For Instructional Use Only.

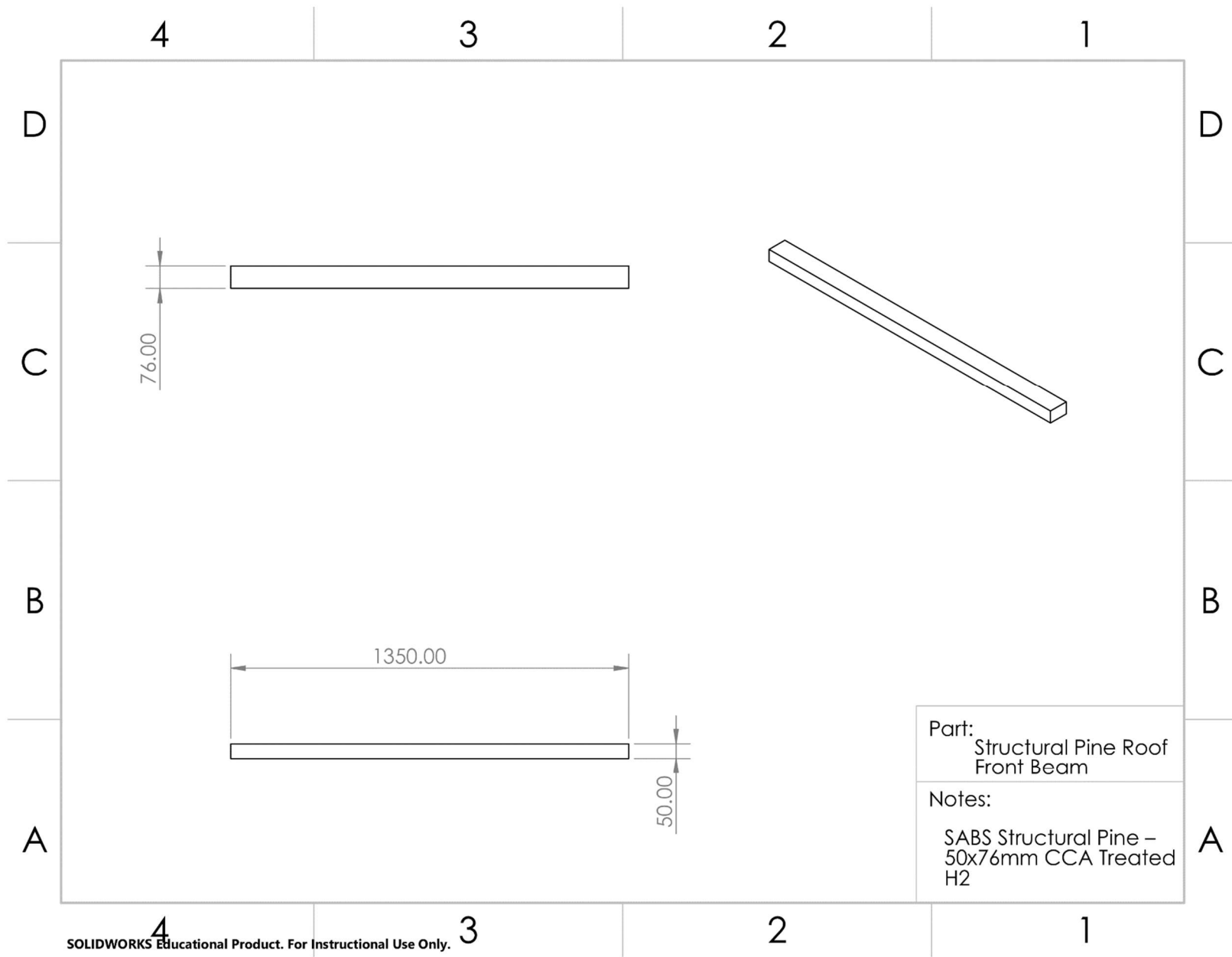




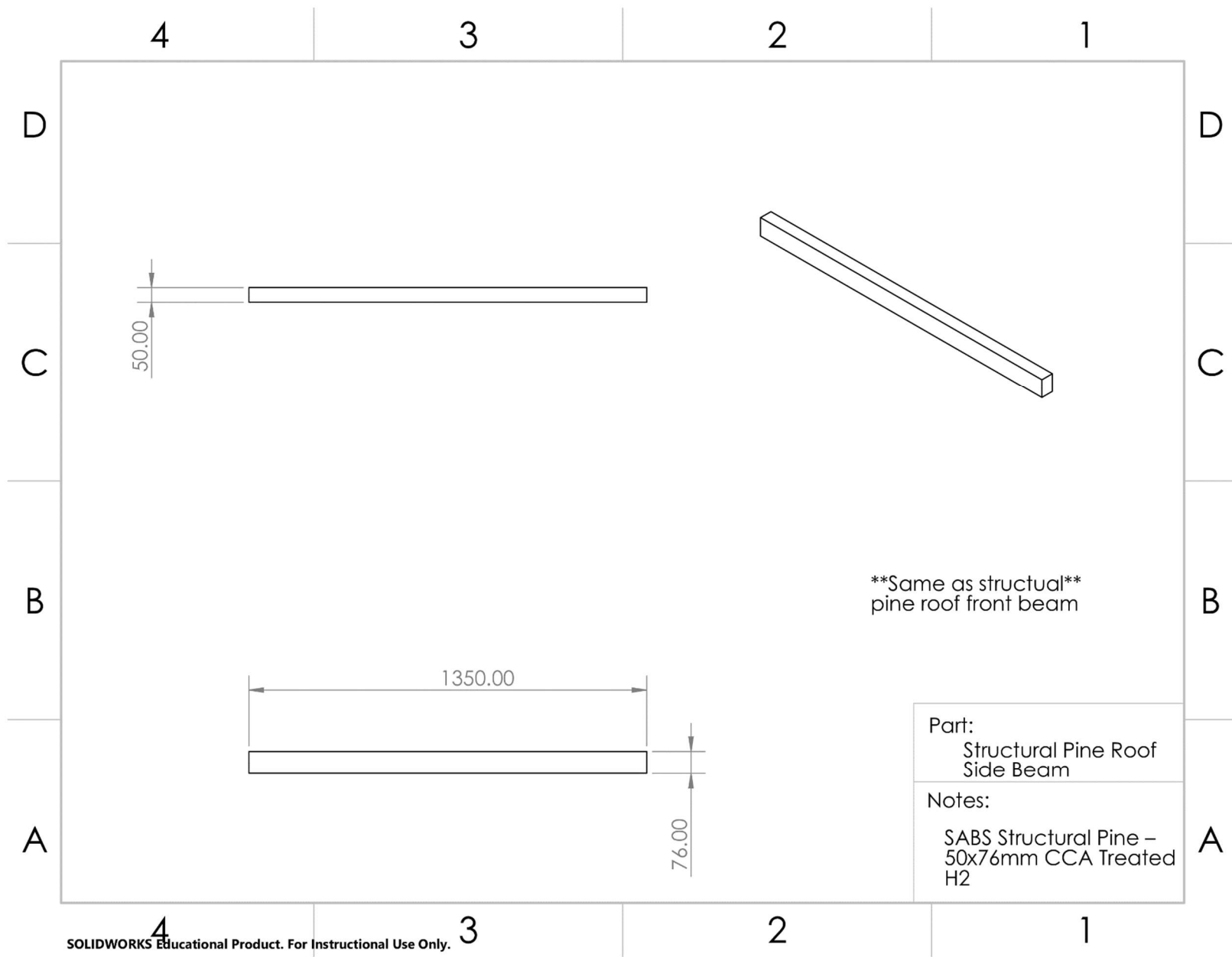
SOLIDWORKS Educational Product. For Instructional Use Only.

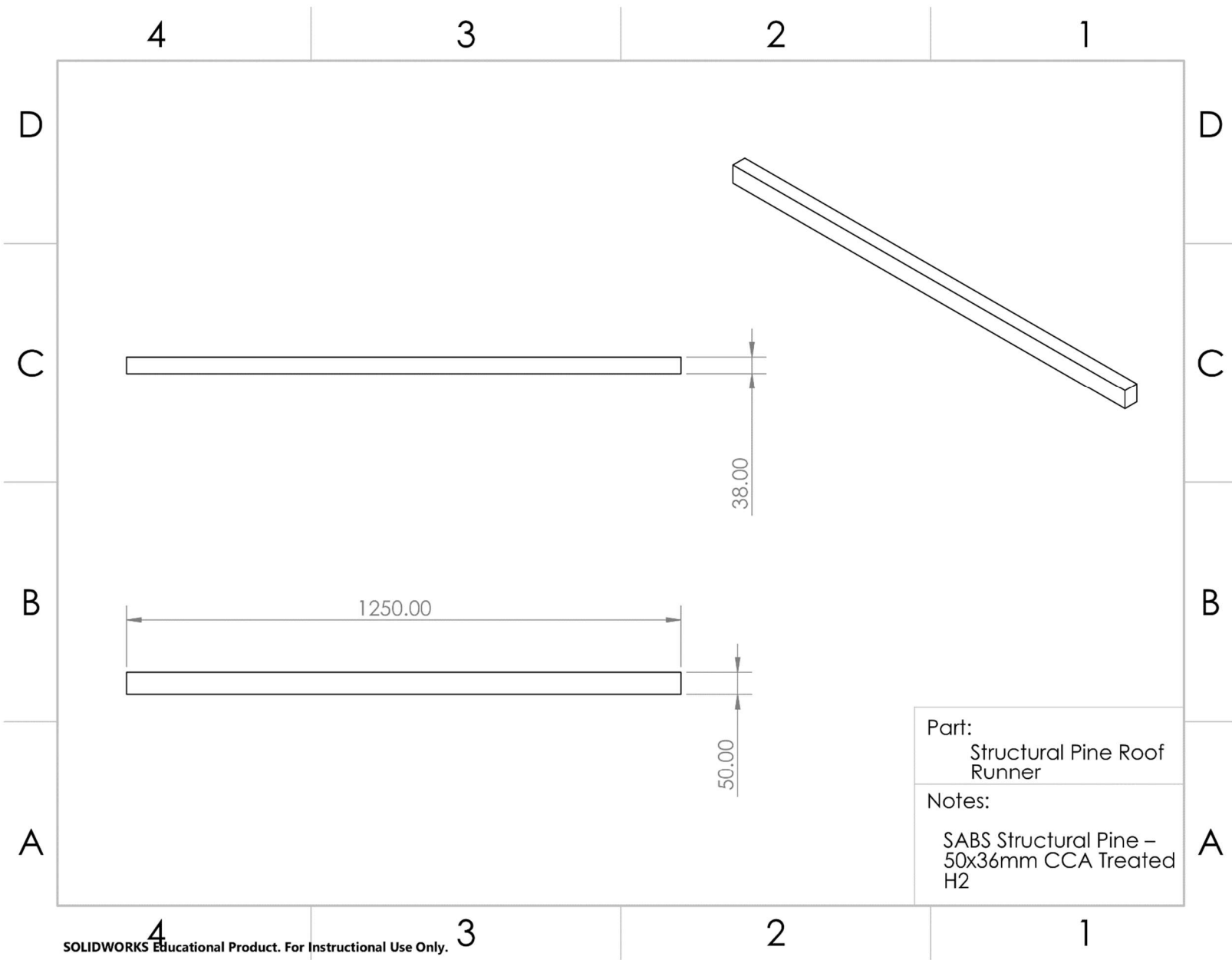


SOLIDWORKS Educational Product. For Instructional Use Only.

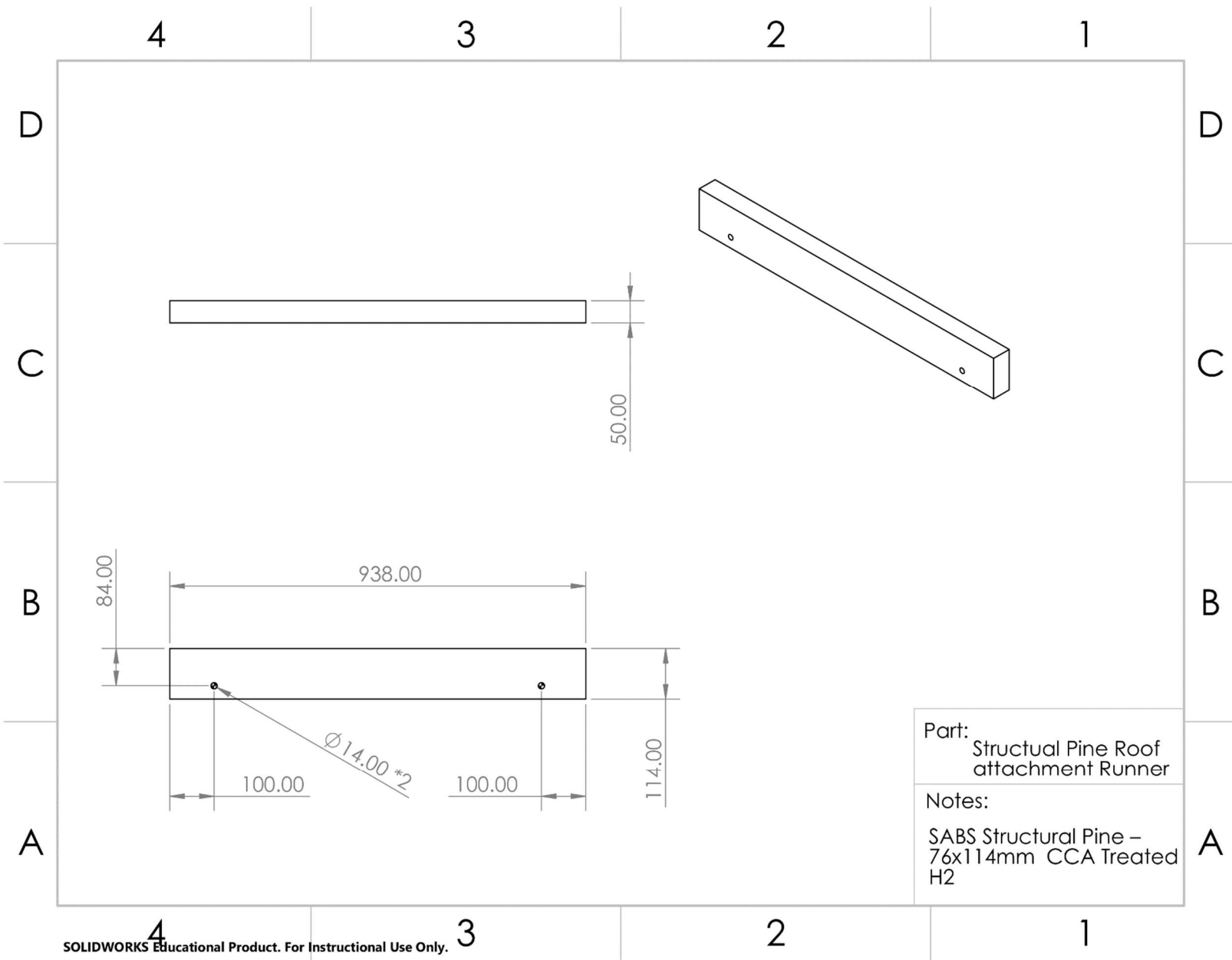


SOLIDWORKS Educational Product. For Instructional Use Only.

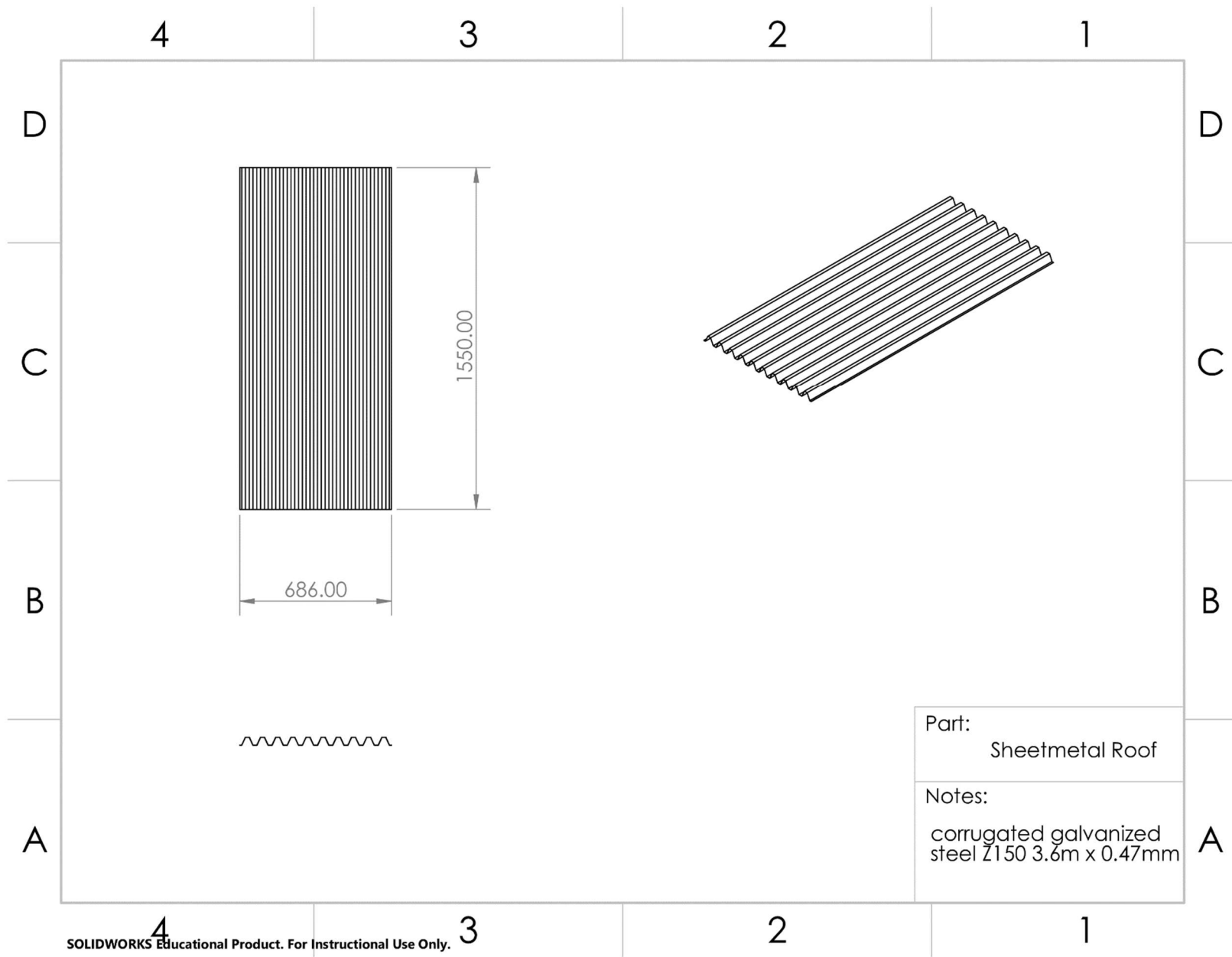




SOLIDWORKS Educational Product. For Instructional Use Only.



SOLIDWORKS Educational Product. For Instructional Use Only.



SOLIDWORKS Educational Product. For Instructional Use Only.

## INTERIOR/CONTENTS OF THE BOOTHS:

Overall, the exhibit should consist of three main booths, each with a different story. Each story should highlight a different childhood experience of growing up in South Africa. The choice of what stories should be included and the development of how they should be presented will be a process beyond our project's reach, but in order to address the message of celebrating diverse childhood experiences, it is important that they cover as broad a range as possible.

The interior of each exhibit will contain a multi-faceted, sensory experience. Before entering the booth, the visitor will press a button, starting the chosen audio recording which will play throughout their visit. There are two main options for the audio component of the exhibit. The visitor could either listen to a recording of the room subject's story (similar to the story room) or they could listen to background noise and music that fits with the theme and time period of the story. Either way, the recording will enhance the visit by adding an additional sensory component and further immersing the visitor into the story being told. Upon walking into the booth, the first thing the visitor will see (on the wall opposite the door) is an image of the room's subject. This will take up a large portion of the center of the wall and will be the focal point for someone first entering the room. Surrounding this image will be a collage of other images from the subject's childhood or images that reflect their experience. These images can be collected directly from the subject and other members of their community. The collage wall will also contain short pieces of text or quotes to complement the imagery. Each of the two side walls will add to the story. One wall will show the story's setting, most likely by depicting the neighborhood the subject grew up in, or one similar to their own. This imagery might consist of a combination of drawings/cartoons (similar to the District Six room walls), real images, and text. The opposite wall will consist of a few more themes. Firstly, to provide context to the story, the exhibit wall should include background on geographic and historic information that might be important in understanding the subject's point of view. On this wall, it would also be useful to incorporate more specific information and facts about the person, such as their childhood favorite games, meals, music, etc., so the visitor can understand some of the ways they might be similar or different than the person who the room is about.

The final element to the booths will be the inclusion of prompting questions. This is an important aspect of all the current rooms at the museum that should be included in the mobile exhibit as well. The questions can be incorporated throughout all three main walls. They should prompt visitors to think deeply about the stories they are experiencing and aid them in developing a deeper understanding of the importance of diverse experiences. It is also important that they provide the opportunity for conversation, especially between adults and children. Some sample questions include the following:

- How can you relate to [name of subject]?
- How do you feel about [name of subject] story?

While the questions should not be so deep so as to confuse younger visitors, they should be thought provoking enough to spark interest and understanding in all who experience the exhibit.

## INTERACTIVE ELEMENT:

The fourth booth will be almost structurally identical to the other three, but the content will be different. It will house an interactive activity which allows visitors to connect the stories of the other three booths with their own story. After walking through the first three booths, the visitors would enter the fourth booth, in which they would have the opportunity to tell their own



story. Instead of a picture of the room's subject on the wall opposite the door, there will be a mirror and a message reading "*Tell Your Story*". Across the rest of the wall will be prompting questions that appeal to a range of ages and address themes from each of the previous booths. These questions are different from the questions contained within the three other booths. The first three booths have questions that ask the visitor to think critically about the stories being told, whereas the fourth booth asks them to think critically about their own story. Some sample questions include:

- What is your favorite game to play?
- What does your home look like?
- *Specific questions based on presented stories.*

One of the side walls will contain a small table or desk with paper, markers, pencils, and other arts and craft supplies. The rest of the blank walls would be filled with clotheslines and clothespins, on which visitors would be able to leave their responses. The visitors would be able to enter the room, think about the questions, draw or write their own response, and either take their response with them or hang it on the wall for other visitors to see in the future. A similar type of "leave-your-mark" activity was successfully used by the United States Holocaust Memorial Museum in their traveling exhibit, *Fighting the Fires of Hate: America and the Nazi Book Burnings* (Badger & Harker, 2016).

Though the fourth booth would be an ideal situation for the interactive element, restraints on time, size, and finances might make it less feasible. Another option for increasing interaction with the exhibit would be to have a table outside the three story booths. This would still allow for visitors to have the opportunity to draw or write their own story without the cost of building and transporting an entire fourth booth. While this option is more cost effective, it loses the sense of cohesion and fluidity that the fourth booth would bring to the exhibit.

#### RECOMMENDATIONS ON NEXT STEPS

Based on our findings and the status of the deliverable, we recommend that the following actions be taken to contribute towards the development of the mobile exhibit:

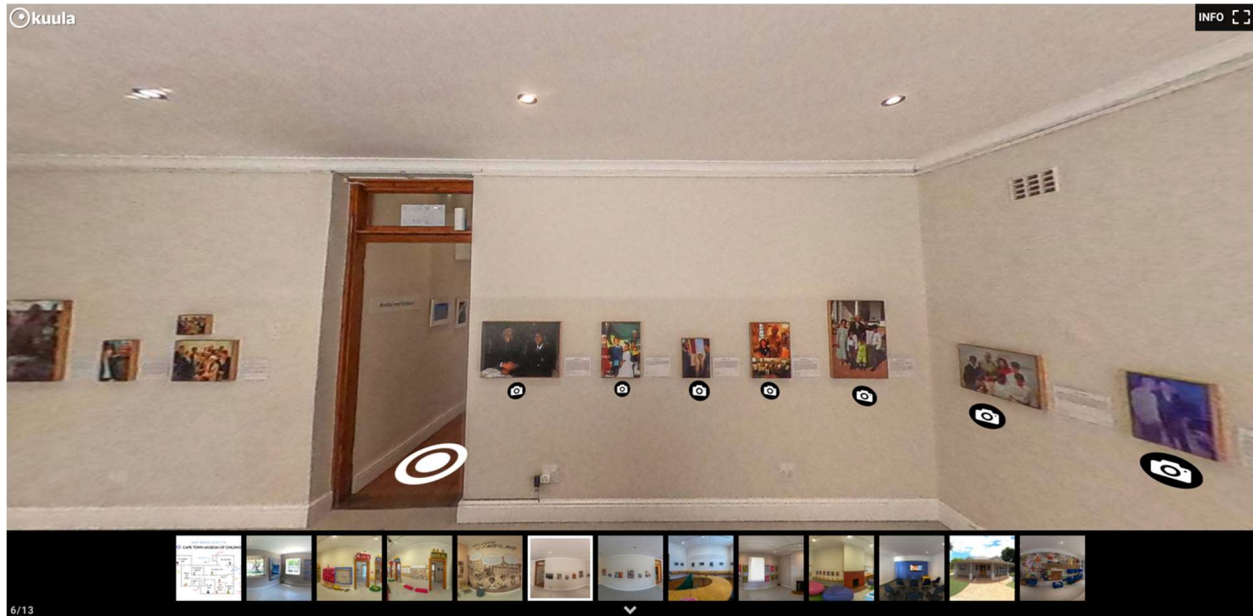
- *Secure funding to support the development and construction of the story booths.* Included in the exhibit description and construction guide is a cost estimate for build materials, but additional costs will include hiring a contractor to follow through with the design process as well as hiring a graphic designer to put together the designs for the interior walls.
- *Determine whose childhood stories will be told in each booth.* This will involve identifying potential story themes, identifying subjects within the community willing to share their stories, performing interviews with each subject, and narrowing down the participant pool to contain a small number of diverse stories.
- *Collect the multimedia elements to support each story.* This will include finding photographs from the subject's childhood (or from people with similar childhood experiences), creating audio recordings of the subject's story, developing graphics to accompany the stories, and collecting the supporting background information to provide sufficient historical and geographic context to the story.
- *Contact and hire contractors and graphic designers to carry out the construction and interior design of the booths.* The blueprints provided within the construction guide should allow for a seamless transition of ideas.

If funding cannot be secured within a reasonable timeframe, it is also possible to create a pilot exhibit which utilizes the overall message and exhibit structure outlined in the exhibit

description and construction guide. A similar experience to what the booth offers can be achieved through less expensive means if the interior of the booths is displayed as large posters. The “Tell Your Story” activity could then be located at a table at the center of these posters, keeping the interactive element intact. In this iteration, the exhibit loses the sense of complete immersion into the life of another, but still allows for the visitor to learn about and picture the lives of those whose childhood experiences differ from theirs.

There is also an opportunity for long term expansion of this exhibit, given it is determined to be a useful resource for the museum after its implementation. The current model for the exhibit calls for three storytelling booths. If the museum decides that the project has been successful though, the exhibit could easily be expanded to contain more booths, and therefore more examples of diverse childhood stories.

## APPENDIX J: VIRTUAL TOUR



*Figure 13. Still Image of the Mandela and Children Exhibit from the Virtual Tour*

Link to virtual tour:

<https://kuula.co/share/collection/79nmM?logo=1&info=1&fs=1&vr=0&sd=1&thumbs=1>

QR Code for Virtual Tour:

