

**A STUDY OF CASE BASED REASONING APPLIED TO WELDING COMPUTER AIDED  
FIXTURE DESIGN**

by

Shaun Price

A Thesis

Submitted to the Faculty

of the

**WORCESTER POLYTECHNIC INSTITUTE**

In partial fulfillment of the requirements for the

Degree of Master of Science

in

Mechanical Engineering

by

---

May 2009

APPROVED:

---

Dr. Yiming (Kevin) Rong, Advisor

---

Dr. Mustapha Fofana, Thesis Committee Member

---

Dr. Richard Sisson, Thesis Committee Member

---

Dr. Cosme Furlong, Graduate Committee Representative

## **Abstract**

This thesis focuses on the application of case based reasoning (CBR) to welding fixtures in a computer aided design (CAD) environment. Modular fixtures have become more popular in previous years due to the creation of flexible manufacturing systems. Modular fixtures, since they are composed of many standardized parts, require much iteration to produce a full fixture design. This process is made more complicated when it is applied to more complex parts such as welding assemblies. In an effort to simplify fixture design for such complicated parts, researchers have been working on integrating fixture design into CAD packages. These efforts, generally known as computer aided fixture design (CAFD), do not focus on the transition of experience from more experienced designers but only provide a structure and a virtual environment to create fixtures. The research presented in this thesis will apply to this area.

Case based reasoning (CBR) is a method of using previous cases to help aid the development of solutions to new problems. Applied to CAFD, this method is reduced to the application of a database and a retrieval and adaptation system. Current research on CAFD and CBR is limited to only proposing systems for machining fixtures. This thesis presents a methodology of a CAFD and CBR system that is dedicated to welding assemblies and fixtures. The focus is on creating an indexing system that adequately represents the workpiece and fixture, a retrieval system that accurately recovers the previous cases, and a method that integrates designer feedback in each process. The results of this thesis will be shown in a case study using an automobile muffler fixture assembly to define each idea of the methodology and to provide an example.

## Acknowledgements

*I would like to thank Professor Yiming Rong for his ceaseless efforts to help make my unusual five year B.S./M.S. thesis possible. I would not have been able to even fathom the possibility of completing my thesis without his guidance and encouragement. I would also like to thank him for his advice during my undergraduate years and suggesting that I pursue the B.S./M.S. program.*

*I am very grateful and would like to thank Dr. Hua Li for his aid and help during my early thesis work. I learned very much under his tutelage and, without his belief in me and my ideas, I would have not have had the confidence I have now.*

*I would also like to express my gratitude to Dr. Hui Wang for allowing me to build off of his previous research, and for his guidance in shaping my ideas and strengthening them with his expertise. I would also like to thank him for going above and beyond what was needed to help and sincerely making sure that I understand the ideas he was proposing, and providing a critical ear to my suggestions.*

*I thank all the members of my thesis committee, Professor Cosme Furlong, Professor Mustafa Fofana, and Professor Richard Sisson for their time and assistance in this process.*

*Finally, I would like to thank Barbara Edilberti for all her help throughout the 5 year B.S./M.S. process and for working very hard and quickly to make sure that everything was all set concerning my graduation requirements.*

# Table of Contents

Abstract.....	i
Acknowledgements.....	ii
List of Figures .....	v
1. Introduction .....	1
1.1. Background .....	2
1.1.1. Flexible Fixturing .....	3
1.1.2. Modular Assembly Fixtures.....	4
1.1.3. Fixture Design.....	5
1.2. Current Research and Trends.....	8
1.3. Thesis Objective .....	8
1.4. Thesis Contents .....	9
2. Literature Review .....	10
2.1. Computer Aided Fixture Design .....	10
2.1.1. Optimizing fixture locations .....	11
2.1.2. Verification.....	12
2.2. Intelligent Methods.....	14
2.2.1. Case based Reasoning .....	14
2.2.2. Current Research on Case Based Reasoning.....	16
2.3. Summary of Problem and Current research .....	17
3. Proposed Methodology.....	19
4. Case Representation and Retrieval.....	24
4.1. Fixture Design Case Information Modeling.....	24
4.1.1. Conceptual Design .....	25
4.1.2. Workpiece-fixture system.....	26
4.1.3. XML representation .....	31
4.2. Fixture Design Case Retrieval.....	32
4.2.1. Similarity Analysis.....	33
4.2.2. Weighting.....	33
4.3. Retrieval System.....	34
4.4. Interface .....	35

5. Case Studies .....	40
5.1. Muffler Case .....	40
5.1.1. Case Information .....	42
5.2. Indexing .....	47
5.3. Retrieval and Modification .....	50
6. Conclusion and Recommendations .....	55
Bibliography .....	56
Appendix A. XML representation of a sample fixturing solution .....	59

## List of Figures

Fig. 1. Bluco modular welding fixture components (Ellig, 2008). .....	4
Fig. 2. Fixture Design Process (Wang & Rong, 2008). .....	6
Fig. 3. 3-2-1 Locating Scheme example. (Carr Lane Manufacturing Co., 2008). .....	7
Fig. 4. Computer Aided Fixture Design Verification system (Kang & Rong, 2001).....	13
Fig. 5. Flow chart of interpretive and problem solving CBR. (Leake, 1996). .....	15
Fig. 6. A general idea of the proposed methodology.....	20
Fig. 7. – Case Retrieval Flowchart. ....	22
Fig. 8. Information modeling and representation flow chart. ....	24
Fig. 9. Indexing Decomposition Structure.....	27
Fig. 10. Varying fixture configurations for the four main types of workpieces (Bluco Co., 2008). .....	28
Fig. 11. Example of a Supergraph (Wang & Rong, 2008). .....	29
Fig. 12. Example of a visual supergraph.....	30
Fig. 13. Single Function, Multiple Function, and Locator/Clamp Fixture Units respectively (Caterpillar, Inc.). .....	31
Fig. 14. XML Script for Fixture Setup.....	32
Fig. 15. Search dialogue box.....	36
Fig. 16. First stage of CBR dialogue box .....	37
Fig. 17. Supergraph import dialogue.....	38
Fig. 18. Second stage of CBR dialogue box.....	39
Fig. 19. Thrush welded muffler case (HSPN news, 2007). .....	40
Fig. 20. First example of a dedicated muffler welding fixture (Peterson Jig and Fixture, 2007). .....	41
Fig. 21. Second example of a dedicated muffler welding fixture (Peterson Jig and Fixture, 2007).....	42
Fig. 22. Case 1 – Flowmaster 60 series Cross Flow muffler (Flowmaster, Inc., 2009). .....	43
Fig. 23. Case 2 – Flowmaster brand 40 series muffler (Flowmaster, Inc., 2009). .....	43
Fig. 24. Case 2 Supergraph. ....	44
Fig. 25. Case 2 Fixturing Solution. ....	45
Fig. 26. Case 3 Flowmaster 80 series Cross Flow muffler (Flowmaster, Inc., 2009). .....	45
Fig. 27. Supergraph of Case 3.....	46
Fig. 28. Case 3 Fixturing Solution. ....	47
Fig. 29. 1 <sup>ST</sup> level case retrieval (by workpiece information).....	50
Fig. 30. 2 <sup>nd</sup> level case retrieval (matching supergraph of fixturing configuration). .....	52
Fig. 31. The new workpiece’s supergraph.....	52
Fig. 32. The supergraph of matched case (case 2).....	53
Fig. 33. Final fixturing solution for new workpiece.....	54

# 1. Introduction

In these troubling economic times, companies are trying to find methods to optimize the production and utilization of their assets. Now more than ever, companies are trying to manufacture and fabricate their goods as cheaply as possible by maintaining high production variability and sustaining low error counts. Additionally, companies are asking younger, less experienced workers to manage projects that are typically selected for more experienced engineers to maintain the knowledge, while reducing the number of workers. The sudden shift in industry has caused additional focus on cost cutting devices and tools that facilitate the acquisition of and maintenance of company specific knowledge and experience from engineer to engineer.

An example of a cost cutting device is a fixture. A fixture is a tool that is used to accurately locate and hold a workpiece in a manufacturing or fabrication process. Fixtures can have applications in machining, assembly, and turning. Fixtures are made for easy loading and unloading and guarantee that a workpiece can be held in the same location repeatedly with minimal variation. The time needed for the fabrication process is reduced and costs are lowered by diminishing the need of potential rework on parts. The focus of this thesis is on welding fixtures which are a type of assembly fixture. These fixtures are made specifically to hold multiple parts together, allow adequate tool passage, resist high heat and sputter, permit passage of weld runoff, and in some cases conduct electricity and provide grounding.

Fixture design has much to do with experience, which the younger engineers generally have been unable to acquire. It can take engineers many years to learn the nuances of the craft. Fixture design can be divided into four major steps, setup planning, fixture planning, fixture unit design and verification. These steps can be generalized as analyze the part, define suitable locating and clamping points, identify tooling and environmental requirements, and create a fixture to satisfy criteria. These steps can be highly subjective and can require an exhaustive trial and error approach until experience is

gained. Fixture design can require weeks to months depending on the experience of the designer. When mistakes are made more time is required and the resulting large number of iterations means higher cost.

Computers have dramatically reduced the design process time. The application of computers to fixture design is called computer aided fixture design (CAFD). By using a computer, designers are able to design in a virtual atmosphere. This helps the designers identify potential problems and undertake different ideas without actually physically creating the fixture. These programs have the added benefit of keeping a designer from missing steps while designing, and by avoiding mistakes time and costs can be kept low.

While there have been many advances in the field of CAFD there are still some fields that need development. For example, there is currently no standard system for welding fixture design that contains an active memory that can suggest solutions to problems. A system that is capable of learning from mistakes and successes, i.e. adaptable; or that goes beyond the simple verification functions that is able to judge a design's quality. This thesis will focus on the research area that has the potential to solve these problems, case based reasoning.

In the following sections an overview of fixtures and their design, CAFD and case based reasoning will be presented. This will lead to a discussion of the literature reviewed which will follow in section 2.

## **1.1. Background**

Fixtures are tools that are used to hold a workpiece in place while it undergoes a machining or assembly process. Fixtures are used to ensure high quality and low variability in parts. Fixtures can be used in low or high volume fabrication operations. Originally the vast majority of fixtures were dedicated fixtures since they were only created for one workpiece. These fixtures have many benefits due to the



high rigidity and the high tolerances that could be achieved but they are also very costly. With the advent of flexible manufacturing systems, setups that are able to change depending on the type of product required to be created, and fixtures that are able to adapt with the changes are the most desirable.

### **1.1.1. Flexible Fixturing**

Flexible manufacturing systems (FMS) by a combination of software and hardware allow manufacturers to produce an extensive collection of products efficiently and effectively. Blending software prediction and planning with hardware variability, FMS's adapt to changes quickly. This is based on the ability of the software to predict and adjust depending on the part needs and the hardware's ability to be re-configurable to the point where they can accommodate a wide array of product needs. Depending on the batch size and required precision and accuracy, fixtures can ensure high production speeds while reducing the amount of rework required. This in turn lowers production costs.

Dedicated fixtures, previously the common standard, were not able to adequately satisfy the desired levels of variability while still keeping production costs low. Dedicated fixtures are fixtures that are produced for one specific workpiece and one setup. Dedicated fixtures have the benefit of high stiffness and are generally used for high batch sizes because they are created to perfectly locate and clamp a workpiece. Flexible manufacturing systems depend on fixtures that are not specific to only one workpiece. They must be able to be reused and changed to accommodate workpiece variations. These variations can include but are not limited to similar parts with different dimensions and odd shaped parts. Modular fixturing systems were looked at as a possible solution due to the high variability and standard set of parts they contained.

### 1.1.2. Modular Assembly Fixtures

Modular fixtures are some of the most widely used fixtures designs (Rong & Zhu, 1999). They are composed of a base with highly movable extensions that allow quick configuration changes. These fixtures can be made quickly using computer aided fixture design tools, and have the benefit of being reusable in multiple configurations. They are also produced to very tight tolerances and can ensure there are few errors in the final product. Modular fixtures can also be standardized to aid in the location of reference points, and have substantial applications in manufacturing processes. Another benefit is ease of storage of modular fixture parts. Small scaled versions can be stored in a cabinet and taken out whenever they are needed.

Fixture components play a major role in the use of a modular Fixture. The designs that are in use now were based on the needs of dedicated fixtures and have been adapted to be adjustable (Rong & Zhu, 1999). Fixture components are made specifically for each type of base plate, but they are generally grouped into the categories: base plate, supports, locators, clamps, and accessories. Components that are produced specifically for the T-slot base plates include the additional categories: guiding components, fastening components, and combined units (Rong & Zhu, 1999). An image of the Bluco Corporation welding components can be seen in Fig. 1.



**Fig. 1. Bluco modular welding fixture components (Ellig, 2008).**

Modular assembly fixtures have different requirements than the standard modular machining fixtures. The fixtures are used specifically to hold multiple parts together so that a joining operation can occur. This requirement is different than machining fixtures since the focus is on resisting the high forces and providing adequate paths for coolant and chips. Welding fixtures focus on providing some rigidity while allowing high loading/unloading cycles. These fixtures must be able to conduct and ground electrical charges in some cases, and resist high heat and sputter. Also, welding fixtures usually have less accuracy requirements than machining fixtures.

While modular assembly fixtures and modular machining fixtures do have different requirements, the method of designing them is relatively standard. The art of designing fixtures requires extensive previous experience and trial and error. This has caused much interest and research in methods to streamline the process and to explain the steps involved.

### **1.1.3. Fixture Design**

Fixture design can be divided into four separate steps, setup planning, fixture planning, fixture unit design, and verification (Rong & Zhu, 1999). A chart of these steps in more detail is shown below in Fig. 2. Before fixture design can be started there are a few preliminary steps. The first is to analyze the workpiece to determine the part design information. This is an analysis of the part to identify the part features and the importance of each feature. This helps in the creation of setups and the order for fabrication. The second step is to create a manufacturing plan. This is more specific information on the tools, speeds and feeds, and the forces exerted on the workpiece. After all these steps are completed then the design of a fixture can be commenced. While some of the previous steps could be considered setup planning, this stage also includes the designation of primary datum and locating features.

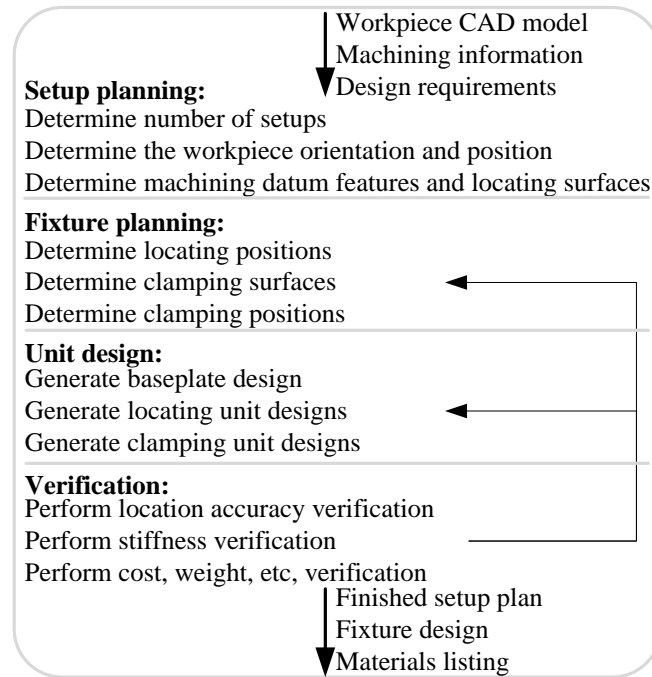

**Fig. 2. Fixture Design Process (Wang & Rong, 2008).**

The next step is fixture planning. This includes the identification of the locating positions, the clamping surfaces and positions. The Six-Point locating principle is the generally accepted locating scheme. It is based on an analysis of the kinematics principle that states that six different points must be in contact with a part in order for it to be fully constrained. Locating is generally split into two methods. The first is the 3-2-1 principle which states that three points must be in contact with the primary datum, two in contact with the secondary, and one contacting the tertiary. This method is used mainly for rectangular shaped parts and is the more used of the two methods. An image of this method is shown in Fig. 3. The second method is the 4-2-1 principle where four points are in contact with the primary datum, two in contact with the secondary, and one in contact with the tertiary. This method is most suitable for cylindrical objects, since more stability is required (Rong & Zhu, 1999).

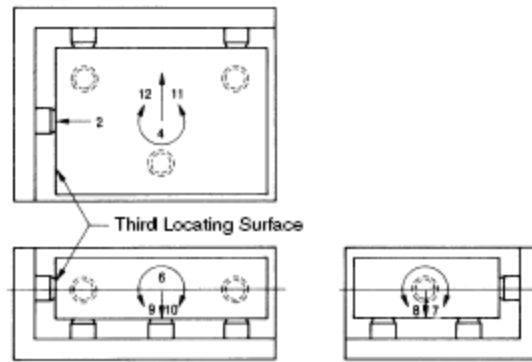

Fig. 3. 3-2-1 Locating Scheme example. (Carr Lane Manufacturing Co., 2008).

Clamps are used to keep the workpiece securely in contact with the locators during the fabrication operation. Clamp planning is usually done following locator planning since clamps are usually placed in direct opposition to the locators and must not share a plane. The clamping force must be monitored to avoid damaging the workpiece during the fabrication process.

The third step is fixture unit design. In this step the baseplate, clamps, and locators are created. Each of these items must be chosen based off of the information determined in previous steps. The baseplate must be versatile enough for the types of clamps and units that are being used. The locators must restrict the degrees of freedom while not interfering with the cutting or assembly tools. Finally, the clamps must not exert too much force on the workpiece but must securely hold the workpiece in place.

The final step is verification. In this step the fixture design is tested to ensure that it fulfills all the requirements of a fixture. These tests include but are not limited to location accuracy verification, stiffness analysis, and cost analysis.

These steps can often be costly, tedious, and time-consuming. Computer based technology has been introduced to help reduce time and streamline the design process. Utilizing computer aided design (CAD) packages for visualization aspects, users are able to create and modify fixtures completely in a virtual atmosphere.

## **1.2. Current Research and Trends**

Computer aided fixture design has been a major focus of research in the recent years. More specifically interest has been shown in the area of integrating fixture design with CAD packages. Some authors focus on single aspects of the fixture design process such as verification such as Kang and Rong (2001). Other authors, Chen et al. (2007), focus on designing a user-friendly interface to combine all the aspects of fixture design into CAD packages.

Another area of interest is intelligent methods for aiding fixture design. These are methods that help designers create fixtures by either optimizing fixture positions, Lazaro and King (1992), or retrieving past information to aid in the development of new solutions, Boyle et al. (2006). These proposed methods have used many different artificial intelligence techniques to accomplish these goals. The popular methods are, case based reasoning, expert systems, rule based reasoning, and genetic algorithms.

While there are many authors who discuss these intelligent methods, very few go into explicit detail about the indexing and representation of complex parts. There are even less who apply these concepts to welding fixtures. These fixtures are more complicated due to the number of parts involved and the intricate fixturing systems. These items will be discussed more in the literature review section, and will be the focus of this thesis.

## **1.3. Thesis Objective**

The objective of this thesis is to:

1. Identify and apply an indexing/representation scheme to welding fixtures
2. Propose a searching method to identify and retrieve the most suitable cases from the case database

3. Provide an interface in which the CBR process can take place.

## **1.4. Thesis Contents**

This thesis is separated into six sections. Following the introduction, Section 2 focuses on an explanation of the research that is currently completed in the fields of computer aided fixture design and case based reasoning. This review is subsequently analyzed to show which areas need more explanation, and then the problem will be summarized and addressed. Section 3 focuses on proposing a methodology to solve the objectives of this thesis. Section 4 further defines the methodology by going into more detail. Section 5 is an application of the methodology to a case study. Finally, Section 6 discusses the results of the methodology and case studies and provides recommendations for future work.

## **2. Literature Review**

Significant progress has been made in the past years in fixture design. Research has been conducted with regards to each aspect of the design phases, and has also lead to the use of computer aided design (CAD) packages in order to increase efficiency. Currently there has been an increase in the production of fixture design specific programs. Within these programs, generally known as computer aided fixture design (CAFD) packages, efforts have been made to help reduce the amount of initial knowledge required for effective use. The efforts include introducing artificial intelligence, by the use of expert systems, algorithms and case based reasoning. Each method has its benefits and limitations.

Within this section an overview of computer aided design will be presented, followed by details on the current research trends with a focus on intelligent methods, and finally the limitations of the research will be presented to clarify the importance of the research presented in this thesis.

### **2.1. Computer Aided Fixture Design**

Computer aided fixture design (CAFD) is the use of computers to help aid in the design of fixtures. These computer based programs help facilitate the designer in steps that were previously very complex. CAFD programs take the creation of fixtures in CAD packages further by not only allowing the building of fixtures but also have assistive properties to help expedite design. These programs contain information on tolerances, forces, and even materials, in order to assist in the production. The additions of 3D modeling and simulation features have improved fixture design and implementation immensely. This is especially important in the development of modular fixtures. These fixtures are generally used multiple times for numerous situations. The ability to simulate production and analyze the forces in multiple configurations eliminates the need for multiple prototypes and saves money as well as time.

Some areas of CAFD are still in development. Integration of CAFD with Computer Aided Manufacturing (CAM) systems is being researched. When CAFD is integrated with CAM systems a



designer will be able to virtually create a workpiece, create fixtures, mount fixtures in desired locations, test tool paths, and run simulations from start to finish. This will allow a designer to go through all the steps for manufacturing without testing on a prototype. This will help reduce costs and prevent many potential mistakes.

CAD/CAM integration by way of Computer Aided Process Planning (CAPP) is studied in the work of Yuru and Gaoliang (2005). In this article an integrated system is proposed that is composed of two modules that handle different aspects of setup planning and fixture design. The articles goal is to add fixture design to process planning so that there can be an easy transition by using CAPP.

This type of research is not the only category of research being pursued in CAFD. There has been substantial research in the areas of optimizing fixture locations and verification of fixtures and fixture solutions.

### **2.1.1. Optimizing fixture locations**

CAFD packages allow the visualization of fixture locations due to the integration in CAD packages, but little information is provided that allows a less experienced engineer to determine the best locating and clamping methods. Researchers are working on methods to help aid in optimization.

The determination of optimal fixture and clamping locations has been a topic of interested for many years. One of the most popular methods of optimization is the genetic algorithm (GA) approach. A genetic algorithm is a search algorithm that mimics evolution by employing evolutionary theory. By using concepts such as crossover, mutation, reproduction, the algorithm provides the optimal solution. Each of the genetic algorithm research papers contains the same general approach with slight variations amongst the papers. The general steps are to determine the machining forces, analyze the deformation from the forces, and then use genetic algorithms to determine the optimal positions to reduce deformation.

Kaya (2005) developed a GA system that uses a chromosome library to reduce the number of function evaluations by 93%. Krishnakumar and Melkote (2000) compared and contrasted two methods of GA in order to identify which method produces the best result. The technique that provided the best results was the second method that performed fixture layout optimization in a single step. Krishnakumar et al. (2002) provide another method of GA layout optimization by varying the fixture layout and clamping force. Aoyama et al. apply GA in order to identify the optimal clamping for an elastic workpiece.

Genetic algorithms are not the only method studied. Wallack (1996) applies a complete enumeration algorithm approach to optimization and focuses his research to modular turning fixtures.

### **2.1.2. Verification**

Another area of research that is prevalent is that of verification. Verification is an important step in the fixture design process since it is important in the determination of the fitness of the proposed solution. Verification processes test the tolerances, stability of the fixture, and fixture constraining ability, etc.

Kang and Rong (2001) propose a fixture design verification Computer aided fixture design verification (CAFDV) which focuses on analyzing geometric constraint, tolerances, stability, stiffness and accessibility, etc. This initial model is further detailed in a three part publication in 2003. The CAFDV system is shown in Fig. 4.

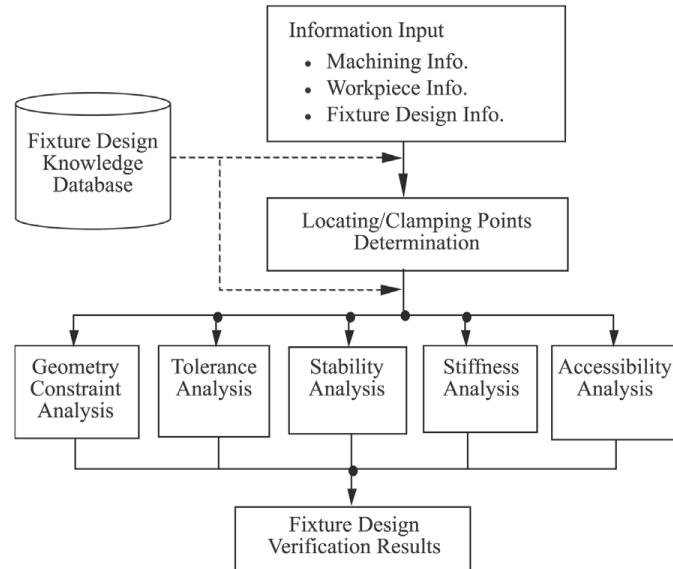

**Fig. 4. Computer Aided Fixture Design Verification system (Kang & Rong, 2001).**

Zheng et al. (2008) propose a stiffness model of a fixture unit. This model is proposed with a method of recognizing contact stiffness parameters. Hurtado and Melkote (2001) also propose a stiffness model for fixtures. The difference is that they optimize the models based on of the tolerance limits. This optimization can create the most feasible dimensions for the fixtures but is based on the assumption that the workpiece is a rigid body.

There are many papers that use a Finite Element Method to predict workpiece deformation and use that as a method of verifying if the fixture is good depending on how much deformation is reduced on the workpiece. Amaral et al. (2005) Satyanarayana and Melkote (2004) use finite element method to determine the effect of elastic deformation and forces on the stability of a workpiece. Siebenaler analyzed the deformation that occurs when contact friction, mesh density and other factors are varied within the workpiece-fixture unit system. Melkote (2006), Ratchev et al. (2007), and Asante (2008) also propose deformation analysis using FEM.

There are limitations to the CAFD research presented in the above sections. While there are some methods that employ intelligent systems to help aid the program user there are still very few

methods that provide more than just basic assistance in optimizing or verifying fixture information. Those items are on the design end of the spectrum. The above research does not provide information on past results and does not automatically modify or provide aid in the modification of designs.

Currently CAFD programs are not able to retain and restore previous designs to suggest new ones based on the previous designs. The designer must remember or review the previous designs in order to identify key lessons to apply to the current problem. CAFD programs are not able to learn from the previous examples to better aid designers. Additionally, these programs are not able to, beyond limited verification functions, judge the quality of a design. There has been development on different systems that are able to provide this level of system intelligence.

## **2.2. Intelligent Methods**

Intelligent methods also known as artificial intelligence methods simulate the processes that a human undergoes when reasoning through a problem. Case based reasoning and expert methods are the most common methods researched. This section will concentrate on case based reasoning.

### **2.2.1. Case based Reasoning**

Case based reasoning (CBR) describes a method that uses previous cases to explain and create solutions to new problems. CBR can be considered reasoning by analogy. Using similar past circumstances to understand and adapt to new issues. There are two major branches of CBR, interpretive and problem solving. A lawyer uses interpretive CBR in daily practice to alleviate or affirm convictions. A lawyer uses previous cases as example of previous decisions in a court room and tries to connect the current case with the previous ones to prove that the same verdict should be made. Problem solving CBR is using a previous method to help determine solutions to new problems. This is done by drawing similarities between the two cases and analyzing specific actions that lead to a beneficial outcome.

Both methods are fundamentally similar in how they are executed. Fig. 5 shows the connection between the two types of CBR. Both methods begin with the retrieval stage, which bring forth the appropriate memory or case for analysis. Based on these memories a general solution is proposed. This is when the two CBR systems split. Interpretive CBR attempts to justify the actions based on the previous memories while problem solving attempts to adapt the previous solutions to match the current issue. Both CBR methods then criticize the proposed adapted or justified solution and evaluate it. If the evaluation is not suitable then the process is returned to the adapt/justify stage. If the outcome is suitable then the case is then stored for future use.

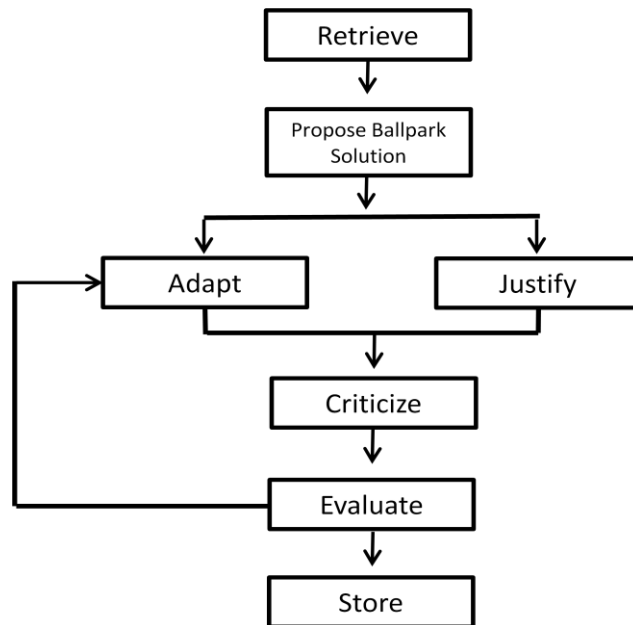

Fig. 5. Flow chart of interpretive and problem solving CBR. (Leake, 1996).

Problem solving CBR can be further broken down in the four stages, index, retrieve, adapt, and revise. Indexing is the identifying and representation of key feature within a case for storage. These features can be information such as geometry, manufacturing information, fixture design information, etc. This information is then stored in a database for retrieval. Retrieval is the method of searching the database to find similarities between the cases based on the indexed information. Adaptation is the changing of the retrieved information to best fit the new problem. The final step is revision which is the

verifying of the fitness of the proposed solution and determining if the process needs to be started over again.

There are many benefits to this system. A major benefit is that specific aspects of a case can be used to help determine solutions rather than having to use it in its entirety. Learning can be achieved regardless of success or failure since both failed and successful cases are stored in the database. The knowledge in the database is solely based on the number and quality of the cases. Cases can be added and removed easily from the database. CBR allows a user to learn from previous mistakes by keeping them stored and easily available. Users will also be more accepting of solutions proposed by CBR systems because the proof is completely visible in the previous case.

The rest of this section will focus the research on problem solving CBR and include information on the case library (database and indexing), similarity analysis (recalling) and Case modification (adaptation).

### **2.2.2. Current Research on Case Based Reasoning**

The case library is the database where the cases are stored for retrieval. There has been little research dedicated to the case library most of the information found was contained in articles that either were creating a full framework for fixture design or those specific to indexing/retrieval schemes.

Boyle, Rong, and Brown (2006) propose a two case library. Subramaniam et al. (2001) propose a full CBR system that uses a genetic algorithm for searching the indexed database. From the search results the system identifies the best result and rates the choices in order for the designer to select which features they would like to reproduce.

Indexing is the method of classifying information so that it can be easily searched and retrieve within the case library. Indexing must adequately represent the information contained within a case and

must be easy to use and search for retrieval processes. Fan and Kumar (2005) provide an indexing scheme using XML formatting. In this paper XML is used because of its versatility. It is a language that is able to be sent over the internet easily and is very popular when creating online web applications.

The search process can be difficult to conceptualize. Many papers use similarity equations to find similar entries in a case library. Mervyn et al. (2005) chose another approach. They use an evolutionary search algorithm in order to produce solutions base on similar functions found in genetic algorithm research. This method provides a thorough search for large databases, but is not needed for a small database such as the one being developed.

The final step in case based reasoning is the adaptation of the case to suit the new design. Aarno et al. (2005) also uses an evolutionary search algorithm to search and adapt fixtures.

### **2.3. Summary of Problem and Current research**

While there have been efforts to automate fixture design by using intelligent methods there are still some areas that could use more development. Case based reasoning research has attempted to add a reasoning method to fixture design and research conducted on CBR has made great strides. There still is more to be done. While it is important to propose general methodologies it is also important to well define proposed methodologies to help aid the development of the research into commercial products.

Case based reasoning also has some problem areas. One of the major problems is that CBR requires a large number of high quality cases to be effective. These cases can be either good or bad cases, but the system still requires a large number of them in order to be the most robust system. In regards to indexing and recalling, determining an indexing scheme and identifying which items should carry more weight when being retrieved are some issues. Adaptation can also be problematic. Identifying what to adapt is an area that causes problems, and in fully automated systems there is the issue of determining what can be adapted and controlling the adaptation process.

The paper written by Wang and Rong (2008) is the basis of this thesis. The approach that is defined in the paper is expanded and more information is added to provide more detail on how to implement this system. The system explain in the paper defines an indexing and retrieval system that solves the issues related above. For indexing the system defines a retrieval system that incorporates human interaction to retrieve the most suitable examples. It uses the human interaction to identify what needs to be adapted, determine what can be adapted, and to control the adaptation process. This thesis will strive to go beyond the overarching explanation, and try to specify and1 improve the approach presented in the works of the authors. Additionally, this thesis will present an indexing scheme that will help in the retrieval process. The proposed methodology is presented in the next section.



### **3. Proposed Methodology**

The case based reasoning system proposed in this paper will focus on the specific aspects of indexing, representation and searching the database for case information and will not focus very much on the final step of CBR, automated adaptation. The concept behind this system is that in order for case based reasoning to reach its full potential the system requires an all encompassing system to adequately define the cases within the database. The proposed system will mimic the design steps of an experienced designer while integrating information garnered from the CAD package to create a complete assembly case. A model of the methodology can be found in Fig. 6.

The model is best read from the top down. This structure shows how the user will interact with the user interface in order to retrieve the most relevant solutions. The first step is for the user to enter the workpiece and manufacturing requirements. This information is entered in boxes that are easily to understand and simple to use. The next step is to enter the workpiece and fixture design requirements. This step is used to aid in the searching process. The CBR system uses this information to retrieve the best solution while incorporating the user feedback during the process. Once this step is complete a final solution is reached and the quality of the solution is then verified.

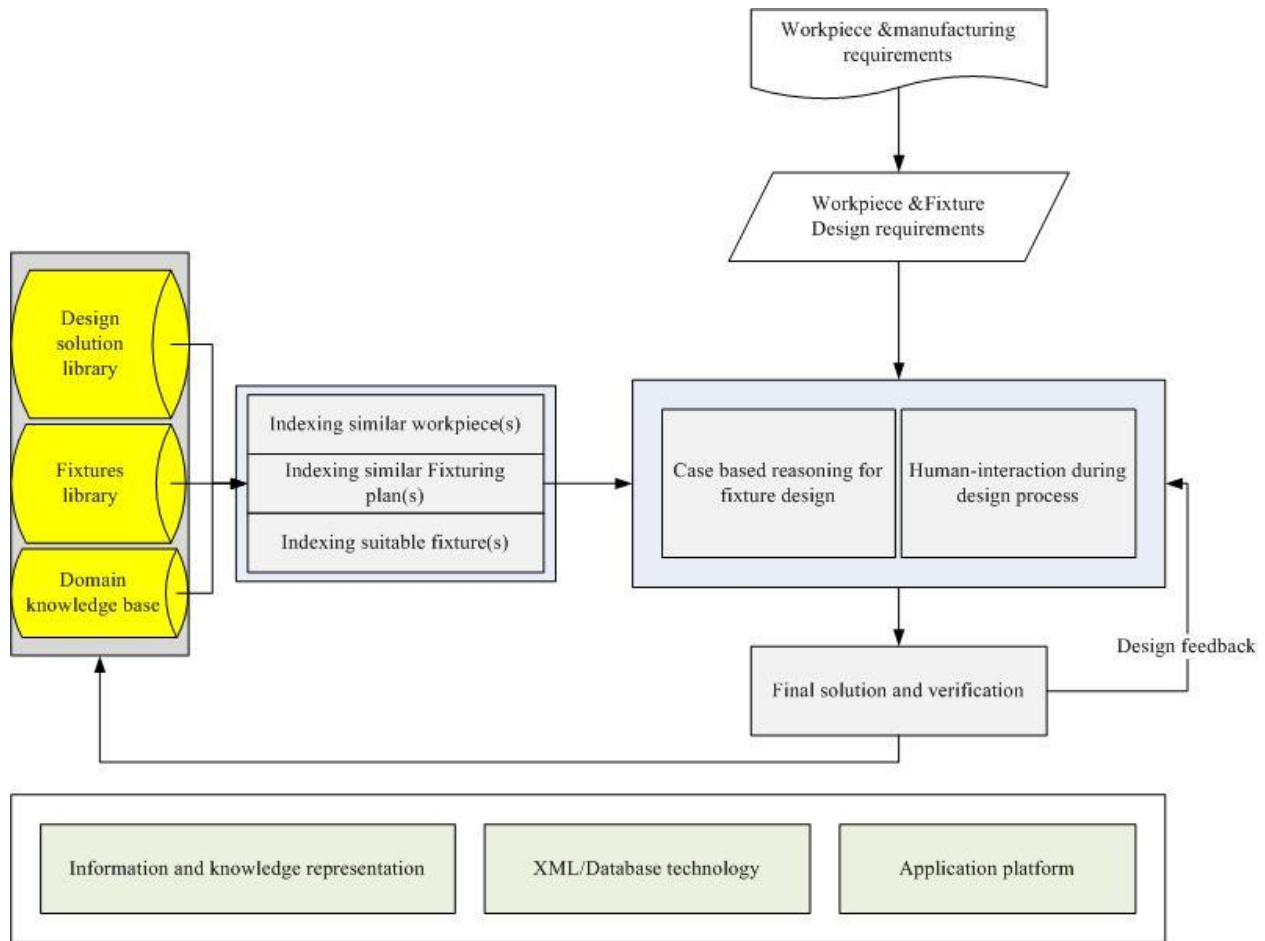

**Fig. 6. A general idea of the proposed methodology.**

The proposed method is further split into three main items that work together to produce the CBR system. The three items are the representation of the information and the knowledge, an XML/Database, and an application platform. The information and knowledge representation is the method of decomposing the information into its component parts. This is generally known as an indexing scheme. These representation methods are stored in the XML databases in an easily searchable fashion. The XML database is made up of another three parts. The first part is the design solutions library, which catalogues all the information pertaining to the entire design (workpiece and fixturing information). The second part is the fixture library. This library contains the information on the specific fixturing units (name, type, size, etc...). The third part is the domain knowledge base. This is the company specific information on general design rules, common practice, and principles of fixture design.

The final section of the methodology is the application platform. This is where the user interfaces with the system and can direct the retrieval system to gather specific results.

The CBR system is not a completely automated one. It is made in a manner that allows constant feedback from the designer and directly uses that feedback to produce increasingly more specific results. The first and most important part of the system is the indexing. The method of defining the case allows the system to retrieve the most applicable solution from the case library. The case library is the location where all of the cases will be stored for retrieval. Each case is indexed within the case library in XML.

The indexing method that will be used in this system is a mixture of attribute-value pairs with some elements of text organized into a hierarchical structure. This system employs a mixture of indexing schemes in order to encompass the full designer's intent as well as the designer's outcome. The attribute-value pairs will be weighted by importance and provide the feature related information. The text will provide the designers intent which is hard to communicate with the attribute-value pairs. The hierarchical structure is to preserve the relationships between the assemblies, its component parts, and fixturing units.

Case retrieval will be conducted in a multi-stage approach which is used to maximize the efficiency of the search algorithm. The stages in the case retrieval multi-stage approach can be seen in Fig. 7. The first step is for the designer to input the workpiece and design requirements into the interface. The first stage of the scan is a surface level search. This search will focus on the input material (workpiece and design requirements) and by similarity analysis the most similar cases will be found. Following this the designer chooses from the cases which one is similar to the new case that is input. After looking at the information in this case and the other similar ones retrieved the designer begins to create a conceptual fixturing plan for the workpiece. This fixturing plan outlines where the designer intends to put the clamps and locators but does not specifically outline which units are used to fulfill those functions.

Based off of this information the second stage of the scan will scan deeper into the library to find cases with similar fixturing parameters. Once all of the solutions are recovered the designer looks through the cases and determines which design is the most relevant case. If the chosen case has the fixturing scheme that the designer desires down to the fixturing unit choices the designer can then choose to go to the verification stage. If the case is not satisfactory then the third search stage will help narrow down more choices.

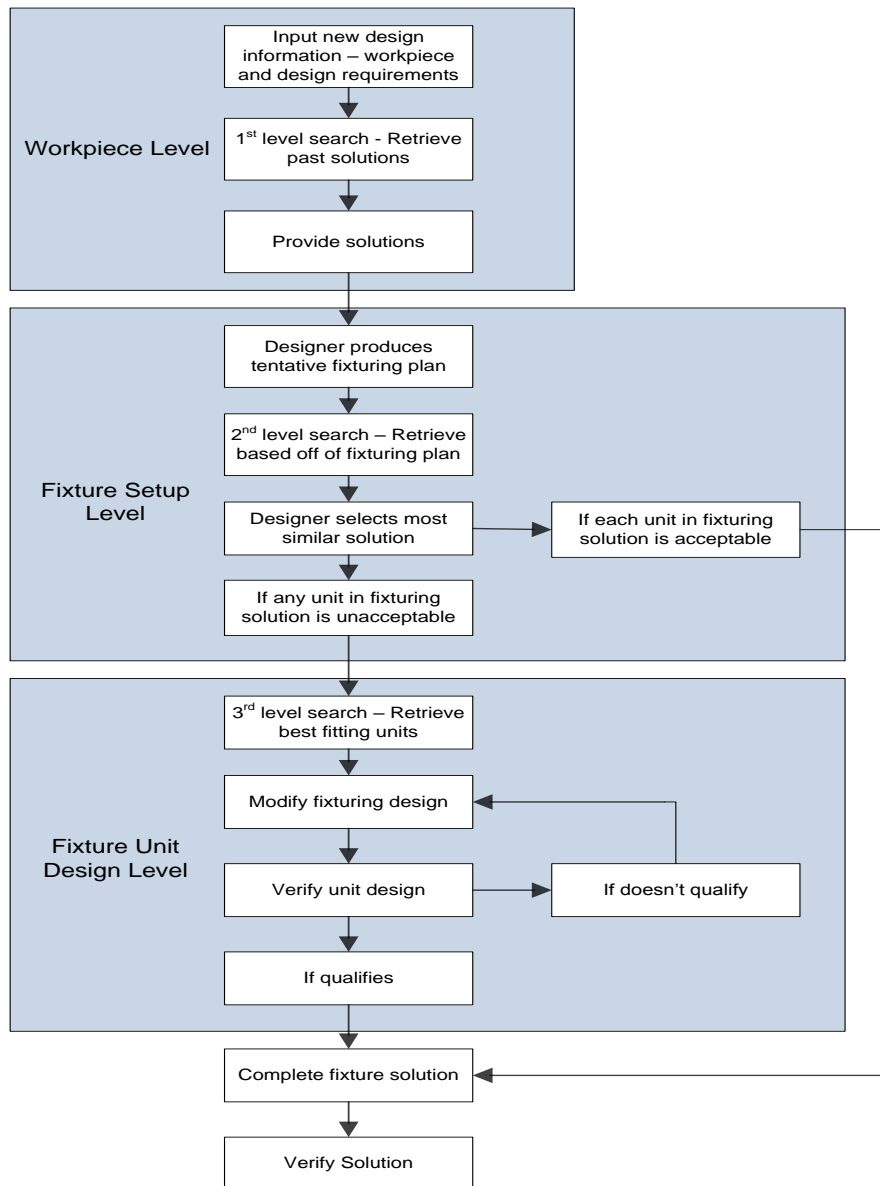

Fig. 7. – Case Retrieval Flowchart.

The third search stage is specific to the fixture unit level. This level searches through the database to find which fixturing unit is the best for the situation. The search provides all the solutions that would best fit with the workpiece and then the designer can choose to accept the unit or go back to any previous step and revise the solution. Within this stage the designer can verify the fixture units by various functions such as an interference check, placement checks, and simulation modeling. Once the designer is finished and content with the finished design the final fixture is then subject to more testing to ensure that the solution is robust.

The benefits to this system are that if only one search was conducted many relevant case options might be neglected. Having a multi-tiered system will iteratively narrow down the selections until the most suitable cases are determined. The human computer interface to help reduce the solutions with the help of visual aids is also another benefit. The next section will discuss the methodology in more detail.

# 4. Case Representation and Retrieval

This section details the proposed system for indexing, representation, and retrieval of a design case. The first section will cover the indexing and representation, while the second section will discuss the retrieval method. The third section is about the interface that has been created for this CBR system.

## 4.1. Fixture Design Case Information Modeling

Case indexing as defined in previous section is the decomposition of a case into its relevant parts. Indexing is the cataloging of every conceivable observation on an item and then storing them in a table. Case indexing in order to be effective must be as comprehensive as possible. The previous research focuses mainly on machining features. This paper will discuss a template for decomposing complex assembly parts. The general flow of the Information modeling and representation is shown in Fig. 8.

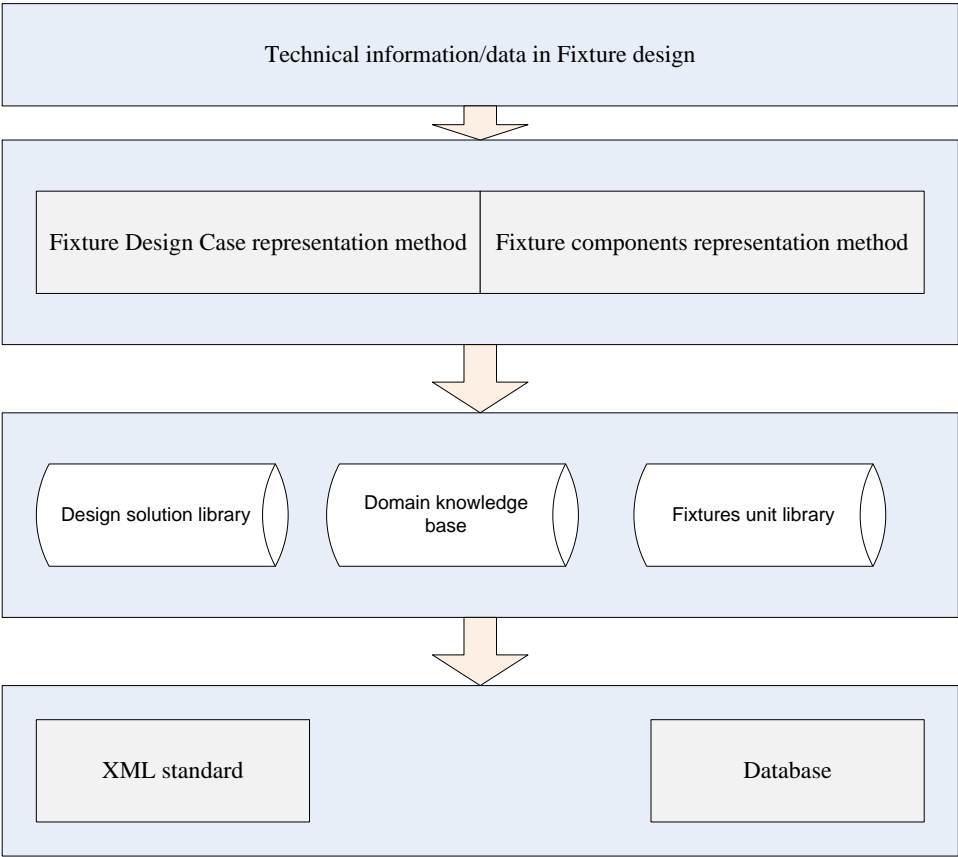

Fig. 8. Information modeling and representation flow chart.

The modeling begins with the technical information for the fixture design. The specifics will be detailed in the following sections. This information is then represented in a hierarchical structure using the XML standard. This information is then further split into the design solutions library, the domain knowledge base, and the fixture unit library. This separate information is stored in a general database which can be easily updated or added to.

The following sections will focus on the specific information that is contained in the database and include information about the representation method eXtensible Markup Language (XML).

#### **4.1.1. Conceptual Design**

The conceptual design is the first step in indexing. The conceptual design is comprised of the initial requirements given to the designer in order to begin formulating a design. The most common information provided is the intended function. This is one of the single most important pieces of information in conceptual design. Drawn from the function are the specifics of potential shape, material requirements, fabrication methods, and others. Additional information that might be provided to a designer is the interaction information, tolerances, environmental requirements, and relative dimensions. Using this information a conceptual design is created.

Important to the conceptual design specifically for assemblies is the function of the part and its correlation to the function of the whole. In an assembly a part is no longer a standalone object, it must fulfill its individual role as well as its role as part of the assembly. The information on how the assemblies are connected physically is important as well. Indexing of this information is very important since it contains information that cannot be directly taken from the final workpiece part. Within this proposed system text will be used to describe most of the conceptual information.

Within the interface the text can be directly viewed and searched. It is separated into sections so that the designer can define the initial concept that was provided. The separation into sections also

allows for searching of a specific topic. For example if a designer is interested in functional properties of a workpiece and wanted to understand the specific reasoning for why component was used that way a search of the text will provide an answer. This text information is considered to be an abstract explaining in 350 words or less what the functional specifications, the reasoning behind fixturing the unit a certain way and possible improvements to the fixture design. Similar to an abstract for an article in a journal, the designer who is inputting the information into the interface will add keywords in a separate section so retrieval can be expedited.

#### **4.1.2. Workpiece-fixture system**

The next step is to capture the workpiece-fixture system. The workpiece-fixture system is an idea group that contains all the knowledge of the workpiece, setup, and fixturing units. The top four levels of this scheme can be seen in Fig. 9.



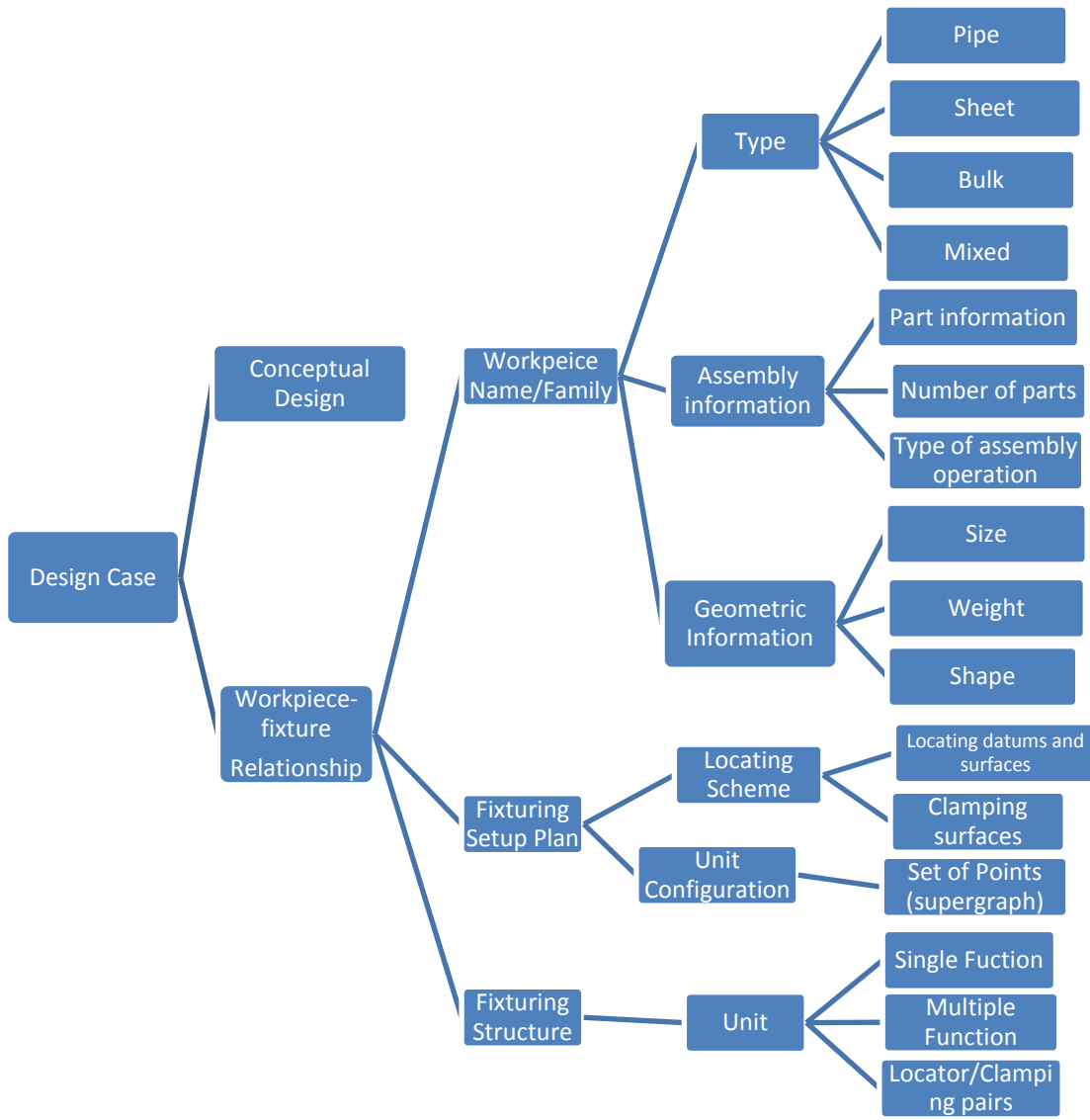
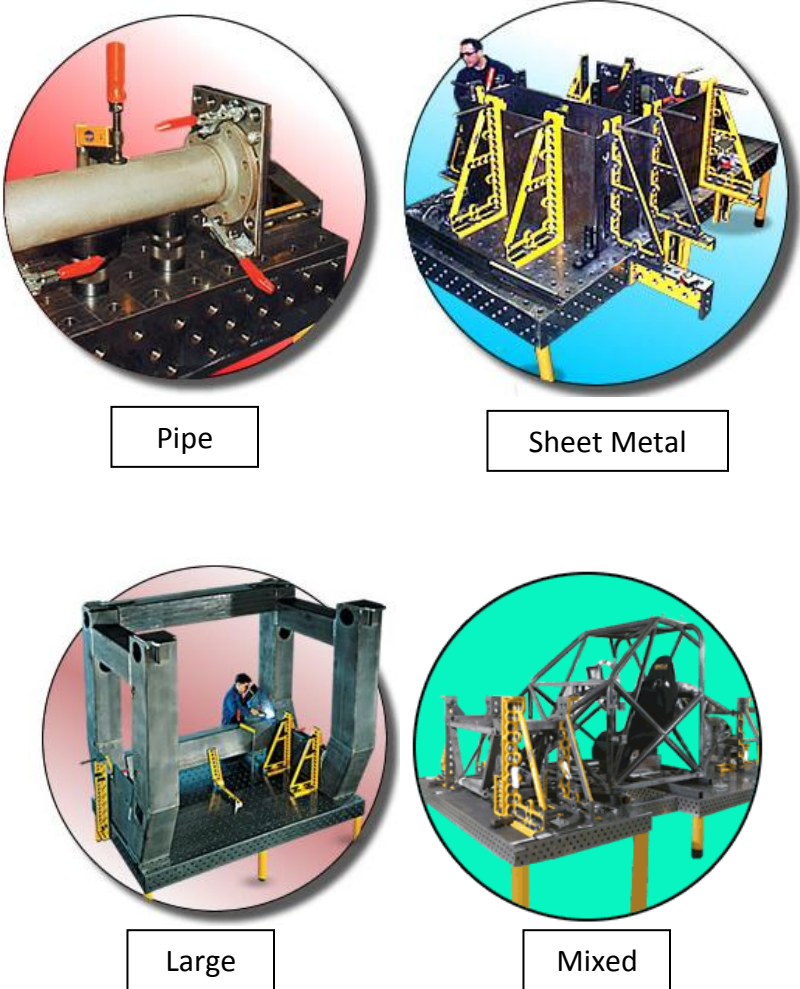

**Fig. 9. Indexing Decomposition Structure.**

#### **4.1.2.1. Workpiece**

The first subsection of the design case is workpiece. This subsection details all of the information about the workpiece. The first item is the name of the workpiece or the family name of the workpiece. This is to identify the workpiece and help group it into a similar family of parts for easy retrieval. This subsection is further decomposed into workpiece specific information such as the type. The different types that are usually welded are pipe, sheet metal, bulk (large parts), mixed (such as automobile which

contains multiple types of parts to be welded). Fixture designs for each of the above mentioned types are shown in Fig. 10.



**Fig. 10. Varying fixture configurations for the four main types of workpieces (Bluco Co., 2008).**

Another subsection of the workpiece is assembly information. This contains information on the number of parts as well as the assembly information. Contained within the assembly information is the number of parts and type of assembly operation. While both the number of parts and type of assembly operation are important this section also contains information about the parts. This subsection contains details about the CAD file. (dimensions, mating constraints, surface interactions, etc.)

The last subsection under workpiece is the geometric information. This contains the size (dimensions), overall weight, and the shape of the part. This subsection pertains to just the overall assembly, not its component parts.

#### 4.1.2.2. Fixturing setup plan

The second subsection under the design case is the fixturing setup plan. This information focuses on the interaction between the locators and the workpiece. Under the fixture setup plan is the locating scheme. This details the locating and clamping datum and surfaces. The unit configuration is also considered and the set of points assembled into a supergraph is defined. A supergraph is a representation of the surfaces and boundaries of the workpiece as a set of points. A supergraph also contains all the information regarding the points that are chosen to be fixturing points, either a clamping point or a locating point. A supergraph represents each of these points in a hierarchical structure. An example of a supergraph is shown in Fig. 11.

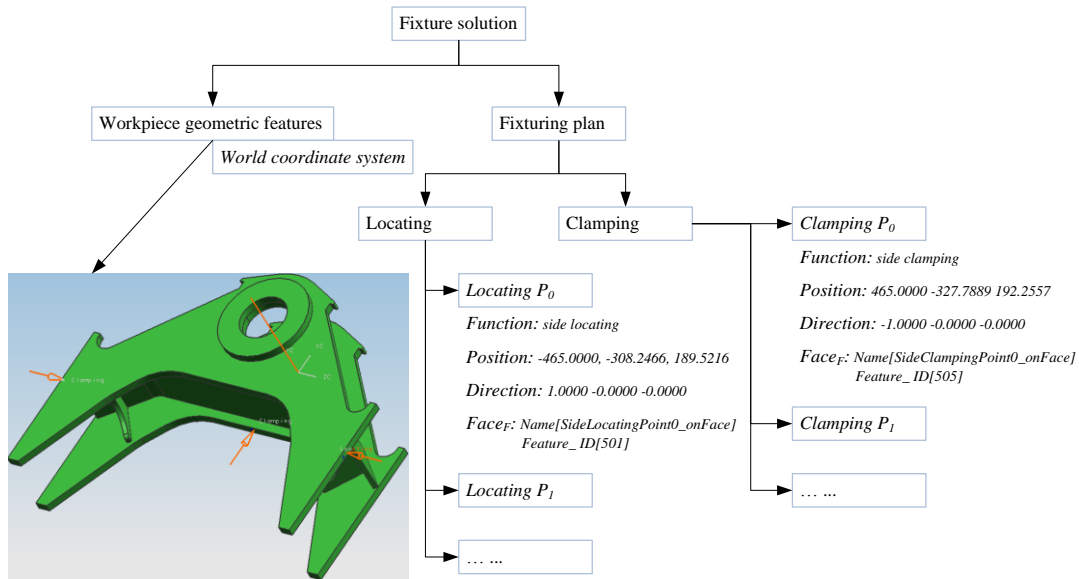
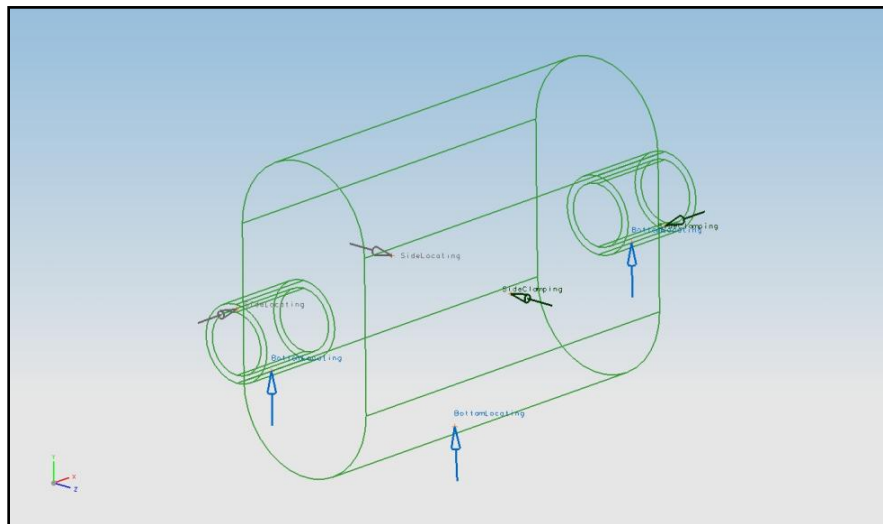

Fig. 11. Example of a Supergraph (Wang & Rong, 2008).

In this system a supergraph is also displayed visually. A visual supergraph is an image that contains a wireframe of the workpiece and each fixturing point denoted by arrows. The arrows are color coded so that each different function is easily recognizable. The blue arrows signify bottom locating points while the grey arrows are side locating points. Finally, the black arrows identify the side clamping points. An example of a visual supergraph is shown In Fig. 12.



**Fig. 12. Example of a visual supergraph.**

#### **4.1.2.3. Fixturing structure**

The final subsection is the information on the fixturing units. It can be said that case based reasoning can be separated into the overall fixture level as well as the individual fixture unit level. This subsection contains all the information on the specific units that can compose a fixture. These units are separated by their functions. There are the single function units which only perform one function such as locating or clamping. Next are the multiple function units that can perform many functions at one time, such as a unit that can bottom locate and side locate simultaneously. Finally, the last subsection under units is the locator clamping pairs. These are pairs of units that work together to fully constrain a degree of freedom. Examples of all of these units can be found in Fig. 13

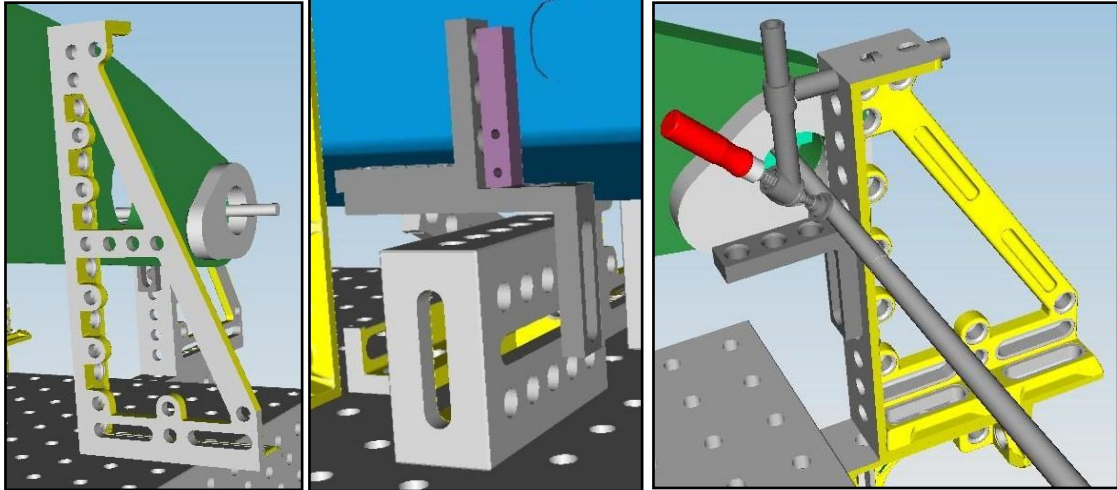

Fig. 13. Single Function, Multiple Function, and Locator/Clamp Fixture Units respectively (Caterpillar, Inc.).

#### 4.1.3. XML representation

Internet and internet based information systems has become a more prevalent foundation for informational storage. Because of this, information needs to be able to be sent over the internet, while maintaining its structure. XML (eXtensible Markup Language) has the benefits of being neutral, platform-independent, and flexible, and allows structured data in web applications (Fan & Kumar, 2005).

Using XML to represent the indexed data will allow flexibility in the database. Since XML is very compatible with web browsers information on cases can be sent over the internet quickly and effectively. The possibility of moving CBR systems to completely web based applications is also a possibility. Using XML a hierarchy can be easily defined by creating parent children tags. These tags can have any name but are used to establish relationships between different parameters. An example of XML script for a side locating point is in Fig. 14.

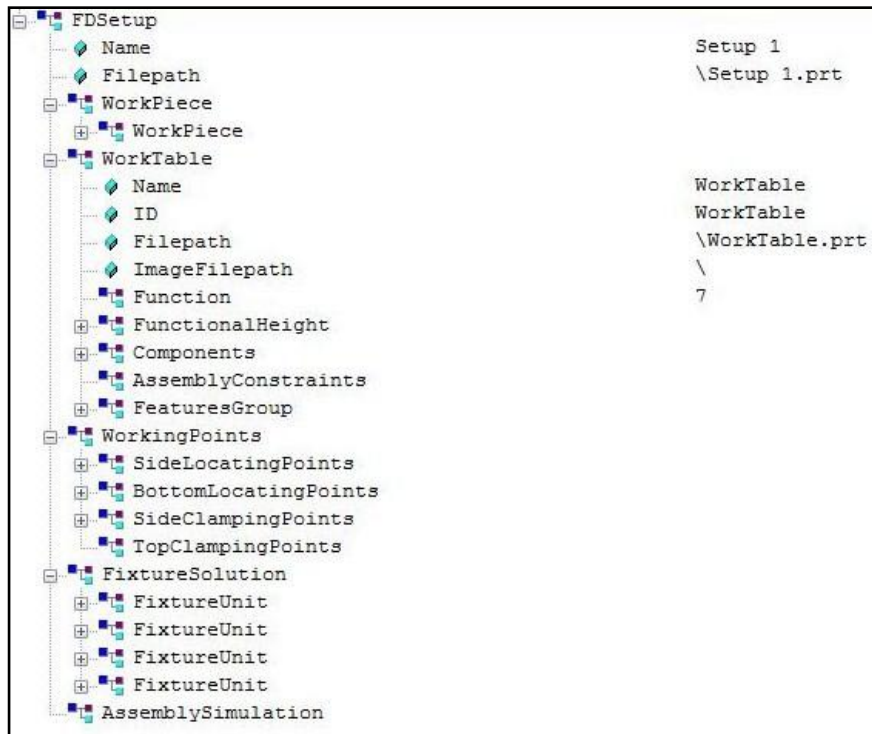

Fig. 14. XML Script for Fixture Setup

The figure shows that the information is clearly separated into the parent and children format. For example FDSetup has the children workpiece, worktable, working points, fixture solution, and assembly simulation. This information can be opened in any web browser regardless of type and still be kept in the same format. A full XML representation sample can be found in Appendix A. XML representation of a sample fixturing solution

## 4.2. Fixture Design Case Retrieval

In the methodology a retrieval process was detailed. In this section the information regarding how the process works will be mentioned. This section is divided into four sections. The first will go into more detail about the similarity analysis while the second section will speak about the weighting system. The third will detail the retrieval system, and the fourth will show the interface and how the user interacts with it.

#### 4.2.1. Similarity Analysis

In this method all of the retrieval is done using a closest neighbor matching scheme. In this scheme the closest match is found by a similarity analysis method. In this case the method that was chosen is to use the cosine formula to find the closest neighbor of feature vectors. A feature vector is technique to represent parts information in a mathematical way. In this case the major information that is turned into feature vectors are the workpiece information, supergraph of workpiece, and the fixture units.

Wang and Rong (2008) best describe the feature vectors for each step. The workpiece feature vector is defined as  $X_{workpiece} = \{F, P, M\}$  where F is the functional features which can be separated into part family, material conditions, and others. P is the physical parameters such as size, shape and boundary features. Finally, M is the manufacturing information like process the workpiece undergoes and quantity. The supergraph information is denoted by  $X_G = \{S_w, P_1, P_2, \dots, P_N\}$ .  $S_w$  is the shape features of the workpiece in the world coordinate system. P is the  $P = \{Function, Position, Direction, Face_F\}$  of each supergraph point. Finally, the fixture unit vector is  $X_{unit} = \{S, F, B\}$  where S is the structural features, F is the functional factors, and B is the behavioral type.

Retrieval of the indexed case is done by similarity measurement. The similarity measurement is conducted using the cosine formula. This equation,  $\cos(X, Y) = \frac{X \cdot Y}{\|X\| \|Y\|}$ , calculates the cosine between two vectors. Similarity is measured by which results are closest or equal to 1. The closer to 1 the more similar the vectors are.

#### 4.2.2. Weighting

The three stage search concept that is presented in this thesis provides for a comprehensive search of cases stored in the case library. By using the similarity analysis of feature vectors acquisition of matching data is very easy to obtain. An important aspect of each stage is specifying searches. In order

to ensure that the most relevant information is retrieved weight is added to each feature to denote which items are more important to each search stage.

The weights to each item are passively added to the system as well as actively. Passively the hierarchical structure allows the broadest categories to be searched first, and then the search will focus on the less broad. This is helpful for the first round of searching where the majority of the information is within the first few levels. The active weighing helps define what is searched first. Active weighing is when a weighting vector is used to influence the outcome of the vector system. Assuming that a vector  $x$  is written in this form  $X = [x_0, x_1, \dots, x_n]$  and the weighting vector is denoted as  $W = [w_1, w_2, \dots, w_n]$  then feature vector defined after the weighting is  $x = \sum_i w_i \cdot x_i$ . The active weighing will be specifically for items such as type, family name, shape, and number of parts.

### 4.3. Retrieval System

The retrieval system is made up of three stages. The first stage is the retrieval and comparison of the workpiece information. In this stage the new workpiece is decomposed into feature vectors which are then compared to those in the case library. When the comparison is complete the cases that matched the new workpiece are then shown and listed based on the level of similarity. Once this information is retrieved the user can select to continue to the next step or they can opt to stop.

The second stage focuses on the supergraph information. After creating a supergraph for the system, the information is then decomposed into a supergraph feature vector. This supergraph feature vector is then compared with the other supergraphs in the case library and the most relevant results are listed in order.

The third stage is the user optional one, where the supergraphs of the new case and the most similar case is compared and suggestions are given regarding what items should be changed. A unit



search is then initiated and the most suitable unit is determined from the functional height of the workpiece. The option to enter specialized custom units is also available.

Finally, the solution is verified to identify if the quality of the fixturing. This is done by interference checks, tolerance analysis, and stability checking to ensure that the fixture is sound. Once a suitable fixture is found it can be saved. All of this information is shown in graphical form in the next section regarding the interface.

#### **4.4. Interface**

The interface for this system is made to be very simple to understand and use. When the program is first opened the first information that is shown is the new workpiece interface. From this screen you are able to load the work part that will be put through the CBR process. The information that is extracted from this is the thumbnail of the picture. On the same screen as the thumbnail is a place where you can enter the information to be searched. This information is type of workpiece, the family name, shape, number of parts, and assembly information. Not all information needs to be entered, but from what is entered the database is searched by those parameters. This dialogue box is shown in Fig. 15.

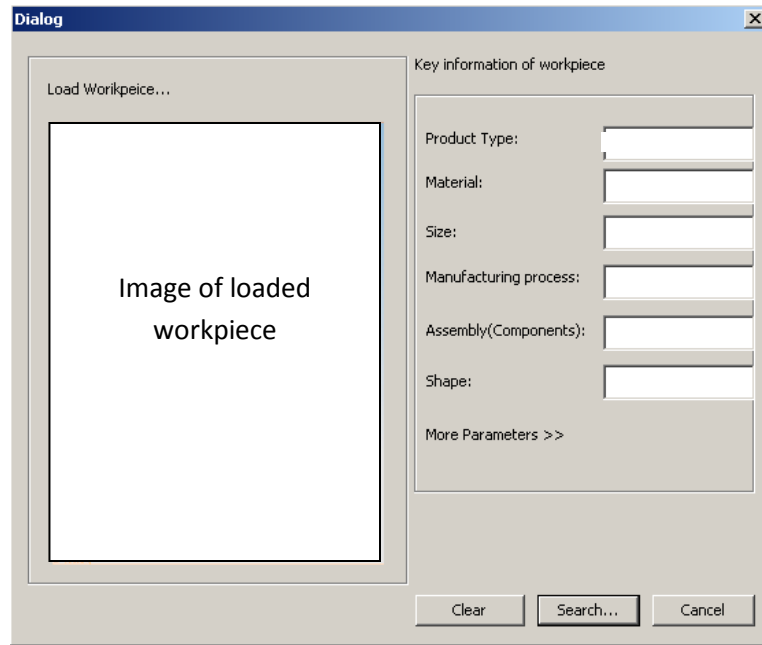

**Fig. 15. Search dialogue box.**

Once this information is searched the first round of retrieval will occur. Then the results of that first round will be shown in another dialog box with another set of options to choose from. At the top of the box is the thumbnail of the current workpiece with the searched information. Below that information are the results listed by name. Once a result is selected the case description and a thumbnail of the workpiece alone and a thumbnail of the workpiece with its fixturing solution is shown. Below this information are the options to finish, go back, continue to the next step, and to cancel.

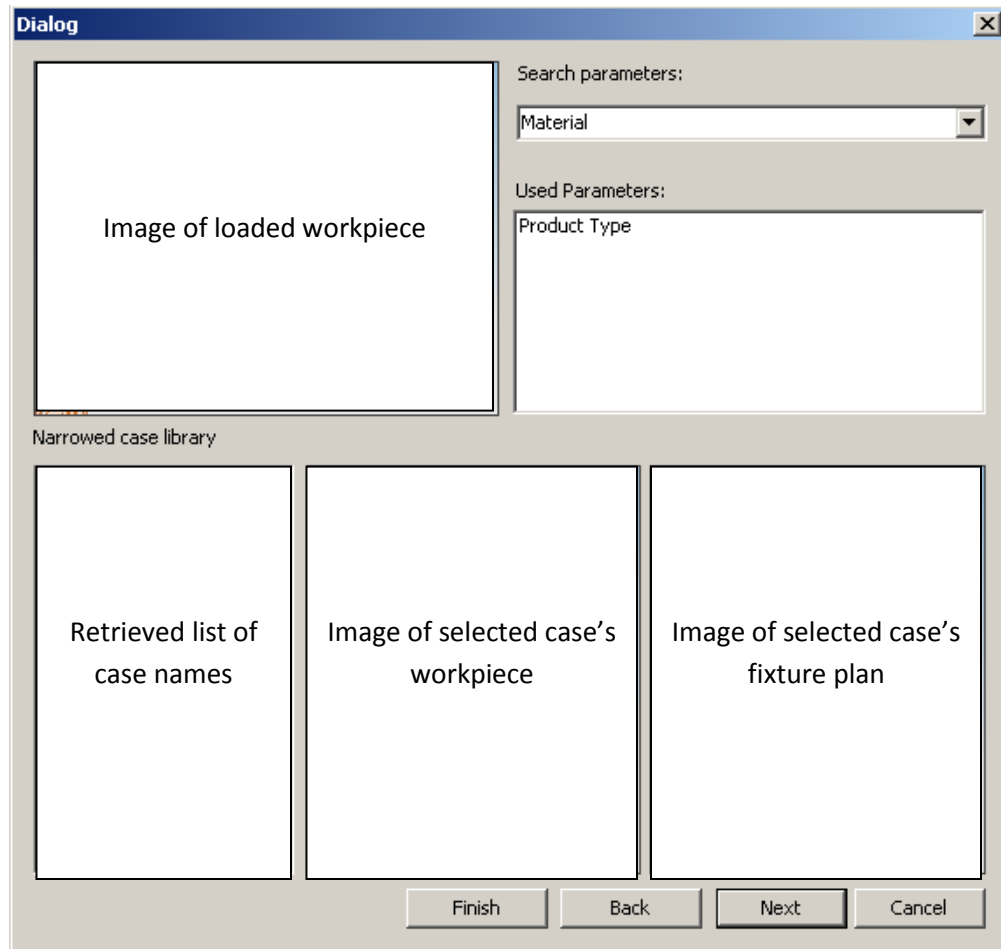

**Fig. 16. First stage of CBR dialogue box**

When the next button is chosen the program allows the user to use the CAWFD interface coupled in UGS (Worcester Polytechnic Institute developed software) to create the fixturing plan for the software. Once this information is finished the information is imported into the CBR process and the next level of searching is started. This dialogue box is shown in Fig. 17.

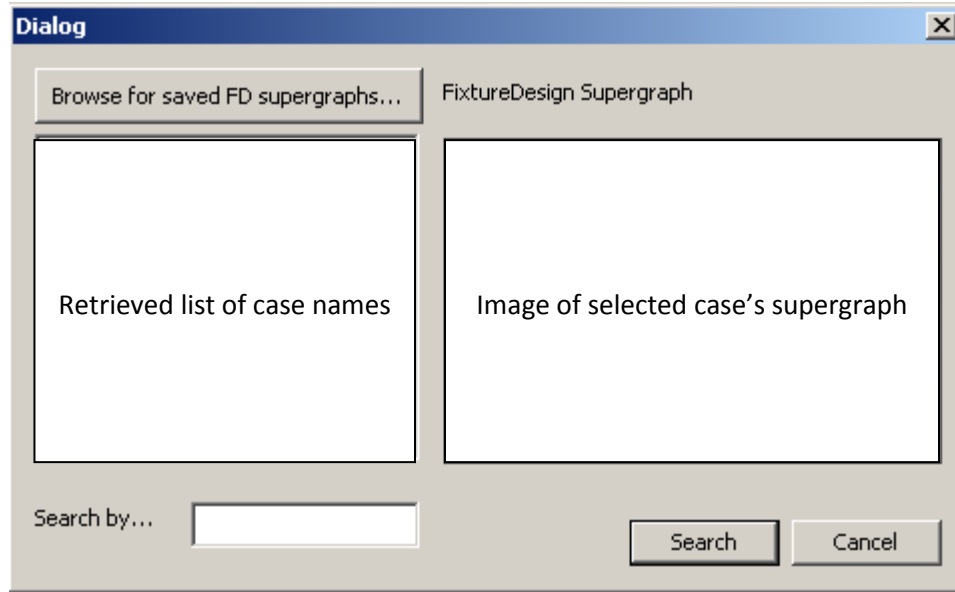

**Fig. 17. Supergraph import dialogue**

Following the second search the next interface box is shown with the results of the search. This information box contains the image of the current workpiece. Next to this picture is the image of the supergraph that was created in the previous step. Below this information is the list of the case result with similar solutions. Once a case is selected the supergraph and the cad model of the fixturing solution will be shown in the box next to it. If the user finds a solution that is acceptable a selection of the Ok button will allow the user to finish the creation of the solution. The other options are to cancel and to go on to the next stage of searching.

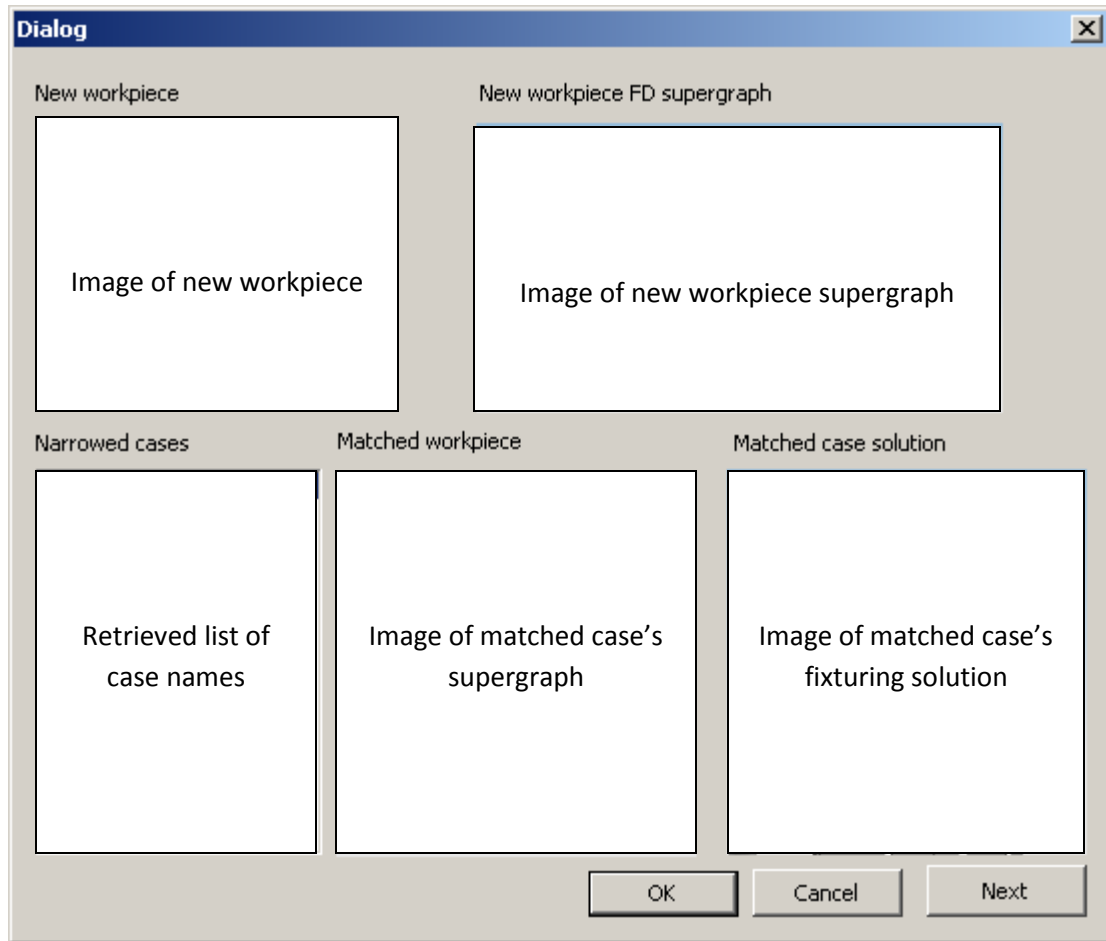

**Fig. 18. Second stage of CBR dialogue box**

The third stage is completed only if a specific unit on the supergraph is not the optimal solution. An information box is shown that contains the fixturing solution for the selected model and allows the user to use the WPI software to begin the positioning and creation of the fixture for the new workpiece. Once the user gets to the part that needs to be changed, the software provides options to auto select the fixturing unit by the height or position of the chosen point of fixture. The user can also import a custom fixture design to be imported to serve as the fixture unit for that point. Once all this is chosen the final option is to go back or finish and the solution is complete. The finish option will lead to the verification steps where the solution will be checked for its quality.

In the next section a case study will be presented to solidify the idea of this methodology.

# 5. Case Studies

In this section the methodology detailed in the previous sections will be implemented and tested to on an example of an automobile muffler. This chapter is divided into multiple sections. The first section will detail the information about the case study. The second section will focus on the indexing of the case. Finally, the third section will detail the retrieval and adaptation of the example based off of the previous cases in the database.

## 5.1. Muffler Case

The system presented in the methodology section will be applied to an example workpiece, an automobile muffler case. A muffler case is typically an assembly of four or five parts depending on the brand or specific requirements of the muffler. The typical welding locations on a muffler case are shown in Fig. 19. Typically a muffler case is welded around the muffler exhaust inlet/outlet (1). This weld is repeated on either side of the case. The case itself can, depending on how it is broken into pieces, be either welded along its cross section (2) or on the outside surface seam of the case (3). The outside seam is also welded on both sides of the muffler case. The addition of these welds can equal anywhere from three to five welds per muffler.



Fig. 19. Thrush welded muffler case (HSPN news, 2007).

The typical welding style for mufflers is metal inert gas welding (MIG), tungsten inert gas welding (TIG), or laser welding. The most preferable is laser welding and when companies make muffler cases it is usually done with robotic arm. The benefits of robotic arms are that they provide the same welds repeatedly. They do depend heavily on workpiece placement since the arm is programmed to do specific moves in a specific sequence and location. Fixturing for a workpiece in a robotic arm is very important. Some robotic arms made specifically for welding mufflers include the addition of variable fixtures to ensure the correct positioning of the muffler. In this example modular fixtures are used in place of the specific robotic arm and fixturing systems. Examples of companies that create commercially available robotic welding systems are Woojin Engineering (Woojin Engineering Co., Ltd., 2003) and BAE design and development (BAE Design and Development, Inc, 2009).

In a search for specific fixtures for muffler welding there were only a few options that were found. There were only two dedicated fixtures and no modular fixtures examples. The two examples are shown in Fig. 20 and Fig. 21. In order for the fixtures to be designed in the CAFD framework that has been developed at Worcester Polytechnic Institute, these fixtures had to be reproduced in a modular fixture format.



**Fig. 20. First example of a dedicated muffler welding fixture (Peterson Jig and Fixture, 2007).**



Fig. 21. Second example of a dedicated muffer welding fixture (Peterson Jig and Fixture, 2007).

The following cases were created based off the information shown above. Each will be TIG welded, and the fixtures will be similar to the industry examples for verification purposes. All the specific details will be shown in the following sections.

### 5.1.1. Case Information

The case based reasoning methodology presented in the previous sections outlines that information must first be stored in a case library in order for the CBR process to take place. In this example the case library has been composed three cases. The cases and their specific information are as follows.

The first case is the case that will be considered the new case. This case is the one that the user is entering into the system in order to find similar cases and to create a fixturing solution. This workpiece is a part of the Flowmaster 60 series and is the standard dimensions for the real part that this model is based on. The muffer is made of steel, contains three separate parts, and is used in sport compact cars



or trucks. The dimensions are 5"x10"x13" for the main part of the muffler and the overall length is 21 inches. The inlet and outlet are both 2.5 inches in diameter. A picture of the case one muffler is in Fig. 22.



**Fig. 22. Case 1 – Flowmaster 60 series Cross Flow muffler (Flowmaster, Inc., 2009).**

The second case is a Flowmaster brand 40 series muffler which is shown in Fig. 23. This case is intended to be one of the reference cases in the CBR case library. It has a similar shape to case one but has slightly different dimensions and a different layout of the inlet and outlet. This type of muffler is normally used in standard size two or four door cars. It is made of steel and its dimensions are 4"x9.75"x13" with an overall length of 21". The exhaust tubes are also 2.5 inches in diameter.



**Fig. 23. Case 2 – Flowmaster brand 40 series muffler (Flowmaster, Inc., 2009).**

As stated in the previous sections the supergraph of a workpiece is the layout of the fixturing points selected on a workpiece. In the case of this software the supergraph is shown in the form of a picture that shows each of the fixturing points denoted by an arrow. Each arrow is a different color to show the different function. The supergraph of case two is shown in Fig. 24. In these images the color

blue denotes bottom locating, grey is side locating, and black is side clamping. This case is made of three bottom locating, two side locating, and two side clamping locations.

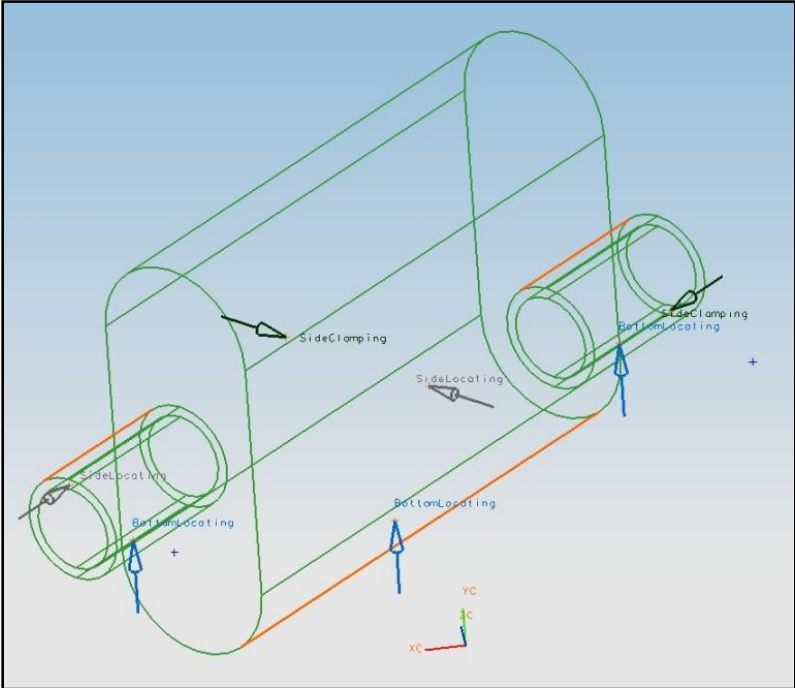

**Fig. 24. Case 2 Supergraph.**

The complete fixturing solution can be seen in Fig. 25. In this case it is positioned in the upright orientation shown in Fig. 20. Even though this fixture is not as detailed as the dedicated fixture, it will serve the same purpose. This fixture is composed of a worktable (Bluco unit D28-01001-001B), three V blocks used for bottom locating (D28-9004-000A), two clamps used for side locating (D28-3002-000C), and two locators used for side locating (D28-03001-00A). There are no top clamping units because the weight of the piece will be sufficient enough to handle the welding stresses put on the workpiece.

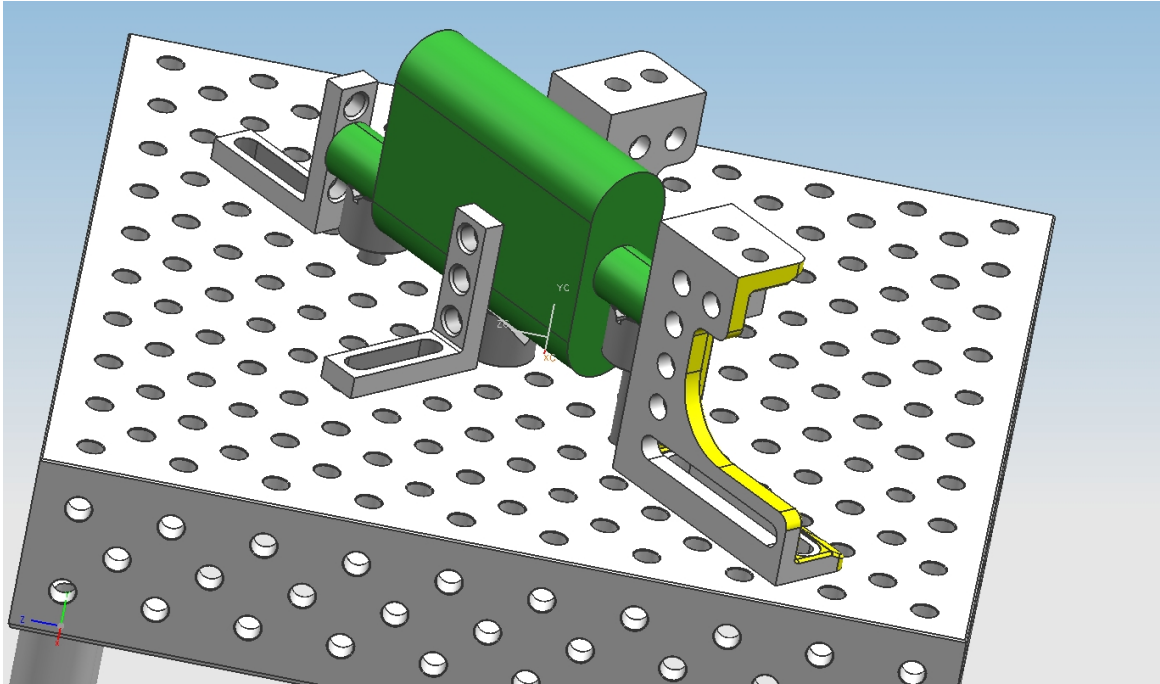

**Fig. 25. Case 2 Fixturing Solution.**

The third case is also used for reference in the case library. This muffler is based on the stock Flowmaster 80 series but its dimensions are two times larger. The reason for this size increase was because the Bluco units are made for larger scaled objects and are a minimum size of six inches tall. The stock model is made for use in the Chevy Camero and Pontiac Firebird. This muffler is also made of steel and its modified dimensions are 8"x19.5"x30" with a 38" overall length. The diameters of the inlet and outlet pipes are five inches.



**Fig. 26. Case 3 Flowmaster 80 series Cross Flow muffler (Flowmaster, Inc., 2009).**

The supergraph of this case is shown in Fig. 27. The supergraph for this case is more complex. The workpiece is intended to be horizontal and is similar to the second dedicated fixture shown in Fig. 21. The supergraph is composed of five bottom locating, two side locating, and two side clamping units. Once again there are no top clamping units due to the weight of the workpiece.

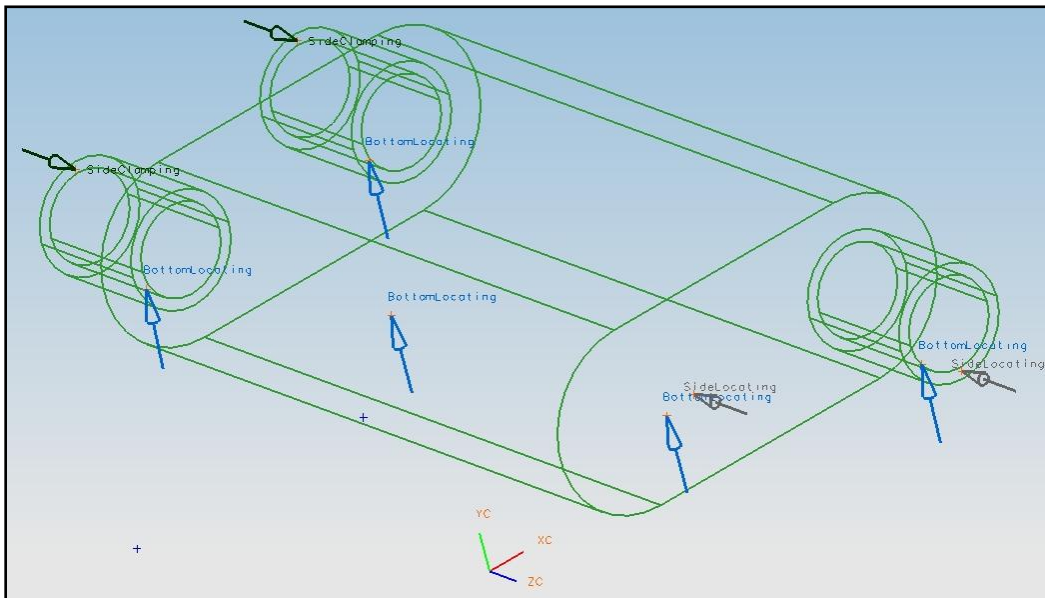

**Fig. 27. Supergraph of Case 3.**

The fixturing solution is different than the previous case. Since the size was increased double of the stock value the system was able to choose more fixtures that are better suited for specific positions. There are a few fixture units that are made up of two components. The table is a Bluco standard D28-01004-001B. The five bottom locating units are comprised of two Bluco standard D28-03005-001A units and three custom units. One side locator is a standard D28-03003-00C and the second is a custom unit. The two clamps are both custom units.

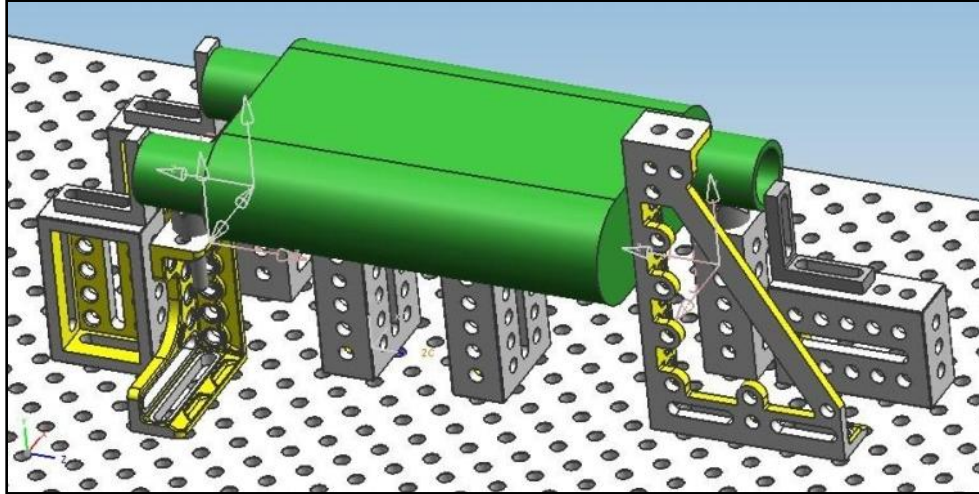

Fig. 28. Case 3 Fixturing Solution.

Once the case library and the new workpiece are defined the next step in the system can be undertaken. The next step is the indexing of the cases using the representation format.

## 5.2. Indexing

The following information is the first three tiers of case indexing hierarchy for each of the three cases. The first case only shows information on the workpiece while the second and third cases contain complete fixturing information.

- Case 1
  - Conceptual Design
  - Workpiece Fixture Relationship
    - Workpiece vector {1, (21, 10, 5), 1, 1}
    - Workpiece: Muffler
      - Type: Mixed
      - Assembly Information
        - 3 parts
        - Tig Welding
      - Geometric Information
        - 4"x9.75"x13"x19"
        - 25lb
        - Cylindrical
- Case 2
  - Conceptual Design
    - The concept behind this fixturing method is to allow easy access to all the joints of fixturing by allowing the individual welding to have access to a 360 space. The

- fixture also makes it easy to access the welds on the seams of the muffler since there is no direct fixturing at that location.
      - Keywords: 360, weld, vertical, v block
    - Workpiece Fixture Relationship
      - Workpiece vector {1, (21, 9.75, 4.5), 1, 1}
      - Workpiece: Muffler
        - Type: Mixed
        - Assembly Information
          - 3 parts
          - Tig Welding
        - Geometric Information
          - 4"x9.75"x13"x21"
          - 25lb
          - Cylindrical
      - Fixturing Setup Plan:
        - Modified 3-2-1 scheme
          - Locating
            - Side: Outlet end surface, muffler side surface
            - Bottom: Outlet side surface, Inlet side surface, Muffler Side surface
          - Clamping
            - Side: Muffler side surface, Inlet end surface
        - Unit Configuration
    - Fixturing Structure
      - Single Function
        - D28-03001-00A
          - 2 Units
        - D28-3002-000C
          - 2 Units
      - V block
        - D28-9004-000A
          - 3 Units
      - Table
        - D28-01001-001B
          - 1 Unit
- Case 3
  - Conceptual Design
    - The concept behind this fixture design is to allow a heavier and bigger workpiece to have ample support for fixturing. This method is also very stable and is easy to load and unload.
    - Keywords: 360, weld, horizontal, v block
  - Workpiece Fixture Relationship
    - Workpiece: Muffler
    - Workpiece vector {1, (38, 19.5, 8), 1, 1}
      - Type: Mixed
      - Assembly Information
        - 3 parts

- Tig Welding
  - Geometric Information
    - 8"x19.5"x30"x38"
    - 30lb
    - Cylindrical
  - Fixturing Setup Plan:
    - Modified 3-2-1 scheme
      - Locating
        - Side: Inlet end surface, Muffler case side surface
        - Bottom: Outlet 1 bottom surface, Outlet 2 bottom surface, Muffler case bottom surface, Muffler case bottom surface, Inlet bottom surface.
      - Clamping
        - Side: Outlet 1 end surface and Outlet 2 end surface
    - Unit Configuration
  - Fixturing Structure
    - Single Function
      - D28-03005-001A
        - 2 Units
      - D28-3003-000C
        - 1 Units
      - Unit\_D28-003001-000A-3\_2\_1
        - 2 Unit
      - Unit\_D28-03001-003A-2-1\_2\_2
        - 1 Unit
    - V block
      - Custom fixtureunit1
        - 3 Units
    - Table
      - D28-01004-001B
        - 1 Unit

Once the information is identified, it needs to be translated into a method that it can be stored. In order to do this, vectors will be used.

For these examples the workpiece vector is the only vector that is determined in a very simplified form. For example the first case's workpiece vector is {1, (21, 10, 5), 1, 1} each term represents information. Since each of the units were the same except for dimensions each of the terms are one except for the overall dimensions of each workpiece. The vector can be defined as {Part family, overall dimensions, shape, manufacturing process}.

### 5.3. Retrieval and Modification

Once indexing is complete the system can be run to retrieve the best matched case from the database. As stated previously, the muffler in case one is used as the new part. In the first dialogue box shown in Fig. 29, the information from the new model is loaded and a thumbnail is shown in the top left corner. Next to the picture is a drop down box that contains all the search parameters. This is essentially a targeted search, where the search looks through the xml to identify the cases with similar parameters. For example when this box is clicked on it will display mufflers as an option. Any option that is selected will show up in the selection box to the right of the tab. As each option is selected the retrieved cases are narrowed down based on the criteria. Each of the options can be selected and the thumbnail of the workpiece is shown on the right.

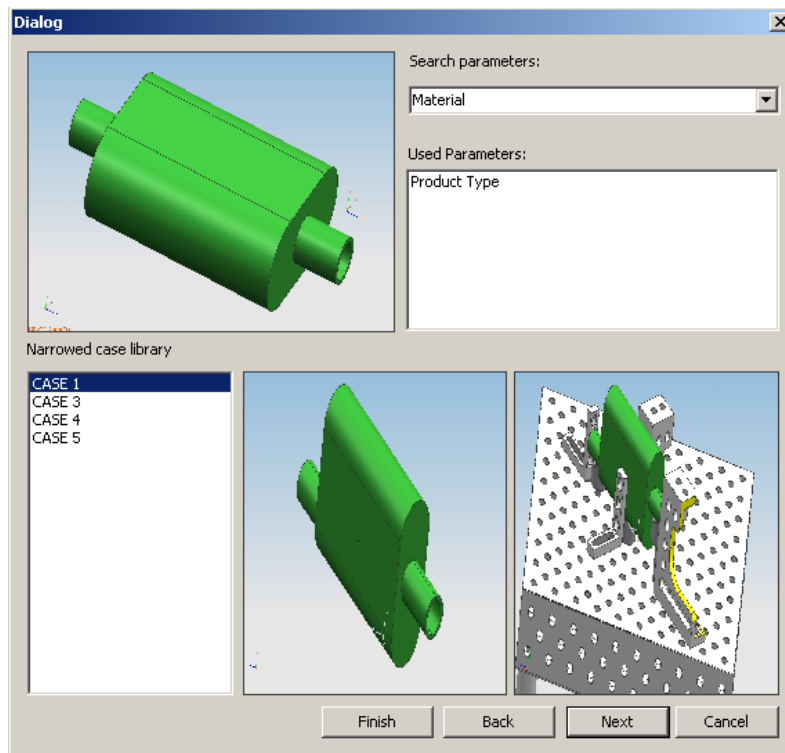

Fig. 29. 1<sup>ST</sup> level case retrieval (by workpiece information).



The similarity is calculated using the cosine formula and if only the dimensions are used as the vector information input into the cosine formula the similarity between case 1 and case 2 is 0.996 or 99.6% while case 1 and case 3 are 0.678 or 67.8% similar. Based on this result the closest option is Case 2, which is selected for the second stage of the CBR process.

Before the second stage dialogue box is used a supergraph is created using the UGS system. Once the supergraph is created the information is imported into the CBR process. This information is used to narrow down the search within the case library. The second stage dialog box is shown in Fig. 30. This dialogue box shows the workpiece in the top left and the supergraph on the right of the picture. Below this is a selection box where a case can be selected and its supergraph is shown to the right. In this instance the best case is case two which is selected and the supergraphs are compared. The image of case one's supergraph is shown in Fig. 31 and the case two's supergraph is shown in Fig. 32.

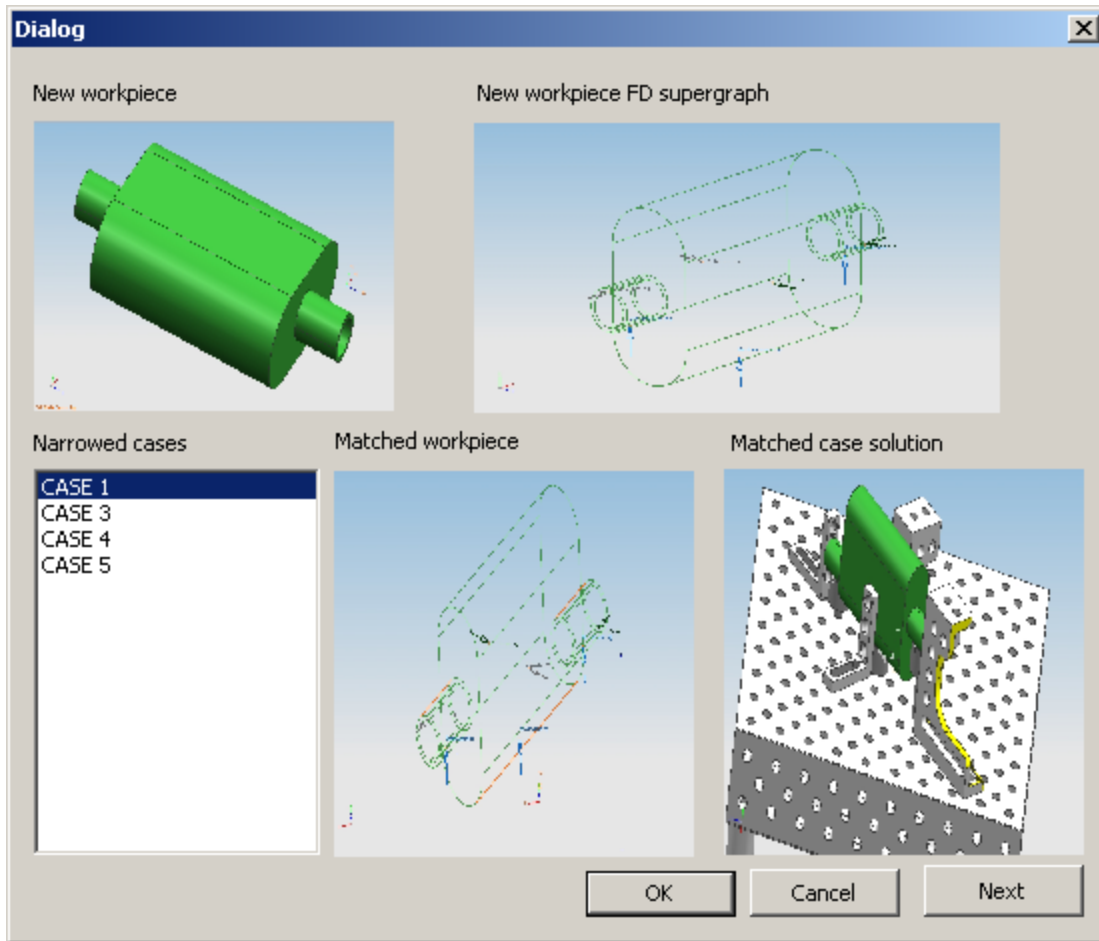

Fig. 30. 2<sup>nd</sup> level case retrieval (matching supergraph of fixturing configuration).

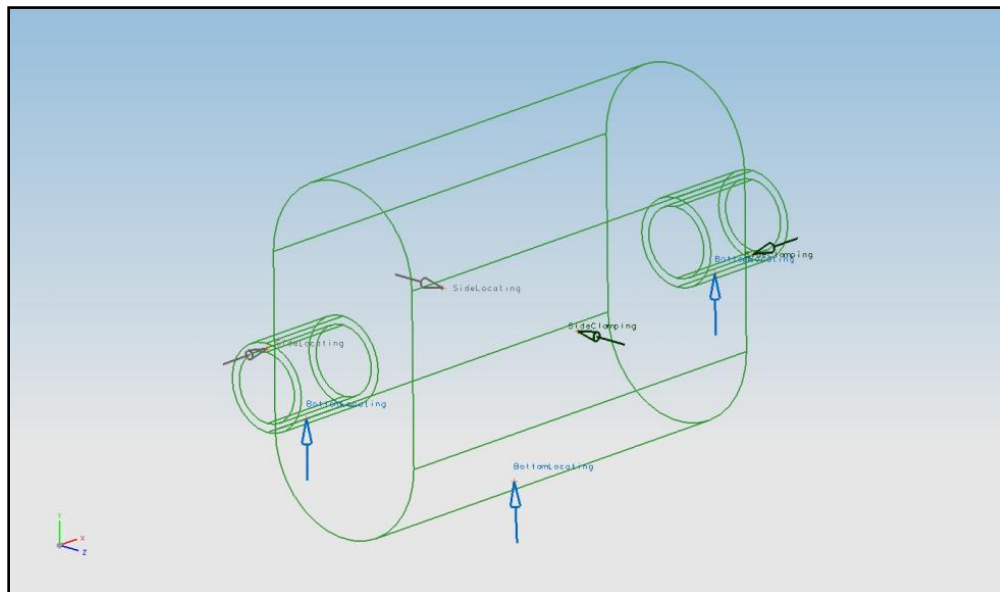
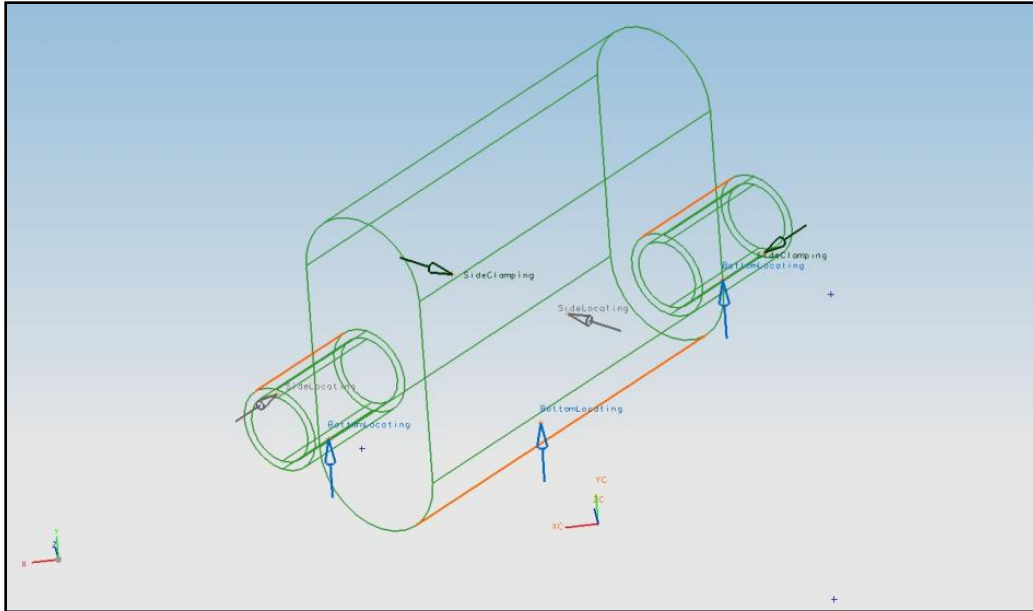
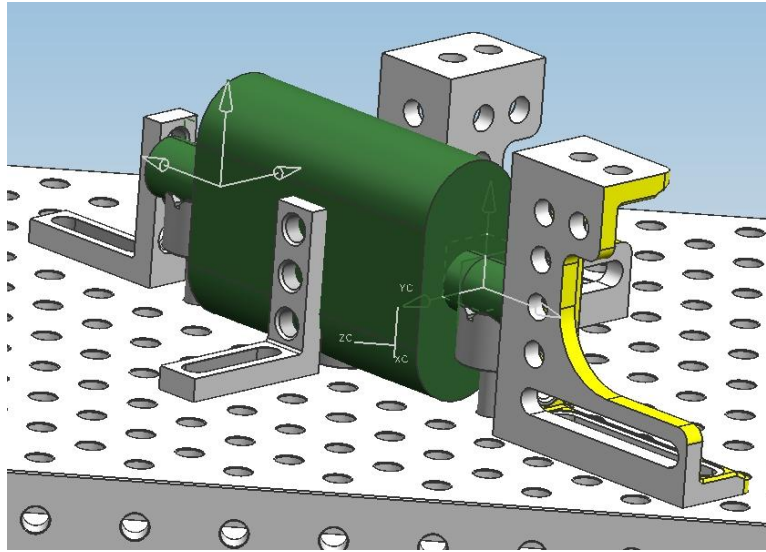

Fig. 31. The new workpiece's supergraph.



**Fig. 32. The supergraph of matched case (case 2).**

Once the most similar case is identified the third stage of search can be conducted if needed. In this case the third stage is used to find a part to bottom locate one of the pipes. This is done by choosing the auto generate option in the WPI CAWFD package, and the fixtures are searched by height and then the best fixture unit can be selected. If a custom fixturing unit is needed then the cad file can be added and assembled into the correct configuration. In this case the same unit could be used to support the new workpiece the location of the part needed to be changed. The final fixturing solution is shown in Fig. 33.



**Fig. 33. Final fixturing solution for new workpiece**

The final step is to verify if each of the fixture units are placed correctly without any interference, and to align each fixture unit correctly. The overall fixture will be checked for stability, interference, and degree of freedom analysis. If the fixture fails any of these tests the software proposes ideas to fix the problems. In this case, the workpiece was fully constrained and no degrees of freedom remain. Additionally, there is no interference amongst the parts and all of the locating and clamping points are in the same plane so the workpiece is stable.

## 6. Conclusion and Recommendations

This thesis defined a CBR system that uses similarity analysis and a three stage retrieval system that incorporates user feedback to produce the best solutions. What was developed was an interface that directly interacts with the WPI UGS system for computer aided welding fixture design, a system that indexed both good and bad fixtures, and retrieved the most similar cases. The application of these methods to the muffler example was meant to show that artificial intelligence methods such as case based reasoning have the ability to make a significant impact on computer aided fixture design.

The application of both the CAFD and the CBR system provided an environment that allowed the creation of fixtures for welding assemblies and the retrieval of past cases. The combination of both of these elements allowed the development of a fixture that based on the historical data stored in cases, provided the support and versatility needed for identifying solutions to new cases. The creation of an indexing scheme specific to welding fixtures also helps fixture designers in the future who are creating similar intelligent systems.

There are some shortcomings to this system. The major one is that while the retrieval process requires a user to help guide the program. There are some other areas that require further research. More research can be done regarding the supergraph information. Currently the cosine formula is not completely effective in producing a well matched solution. If a better solution was created CBR within this system would be better. Another area of research is the creation of a detailed indexing scheme that specifies data for multiple types of assembly fixtures would aid in the development of complete CBR systems. Finally, the creation of a fully automated system with automated adaptation is another area for future development.

## Bibliography

Amaral, N., Rencis, J., & Rong, Y. (2005). Development of a finite element analysis tool for fixture design integrity verification and optimization. *The International Journal of Advanced Manufacturing Technology* , 409-419.

Aoyama, T., & Kakinnuma, I. (2006). Optimization of fixture layout by means of the genetic algorithm. *Innovative production machines and systems (IPROMS)* .

Applied Design Technologies Inc. (2005). *Applied Design Technologies Inc.* Retrieved December 6, 2007, from <http://applieddesigntechnologies.com/graphics/FEA-Stress-Plot-Cosmos.jpg>

Asante, J. (2008). A combined contact elasticity and finite element-based model for contact load and pressure distribution calculation in a frictional workpiece-fixture system. *The International Journal of Advanced Manufacturing Technology* , 578-588.

BAE Design and Development, Inc. (2009). *BAE Design & Development, Inc.* Retrieved April 30, 2009, from BAE Design & Development, Inc: <http://www.baedesignanddevelopment.com/>

Benhabib, B. (2003). *Manufacturing Design, Production, Automation, and Intergration*. New York: Marcel Dekker.

Benhabib, B. (2003). *Manufacturing Design, Production, Automation, and Intergration*. New York, New York: Marcel Dekker.

Carr Lane Manufacturing Co. (2008). *General Information, On-Line Jig and Fixture Handbook, Locating and Clamping Principles*. Retrieved March 11, 2009, from Carr Lane Manufacturing Company: <http://www.carrlane.com/Catalog/index.cfm/29625071F0B221118070C1C513906103E0B05543B0B012009083C3B2853514059482013180B041D1E173C3B2853524B5A59>

Ellig, B. (2008, June). Think Outside the Box. *Canadian Metalworking* , pp. 87-91.

Eslava, A. (2001). *Finite Element Analysis Study on Fixture Workpiece Deformation*.

Fan, L. Q., & Kumar, A. S. (2005). XML-based representation in a CBR system for fixture design. *Computer-Aided Design Applications* , 339-348.

Flowmaster, Inc. (2009). *Flowmaster, Inc.* Retrieved April 27, 2009, from Flowmaster, Inc: <http://www.flowmastermufflers.com/mufflers.html>

Hou, Z. (n.d.). ME 4512: Introduction to the Finite Element Method. Worcester, MA, USA.

HSPN news. (2007, January 23). *Thrush Launches New Welded Muffler, Stainless Steel Glasspacks* . Retrieved April 27, 2009, from HSPN Global News: <http://news.hspn.com/articles/1265/1/Thrush-Launches-New-Welded-Muffler-Stainless-Steel-Glasspacks/Page1.html>

Hurtado, J. F., & Melkote, S. N. (2001). Improved algorithm for tolerance-based stiffness optimization of machining fixtures. *Journal of Manufacturing Science and Engineering* , 720-730.

Kang, Y. (2001). *Computer-aided Fixture design verification Phd. Dissertation*. Worcester, MA: Worcester Polytechnic Institute.

Kang, Y., Rong, Y., & Yang, J. C. (2003). Computer-aided fixture design verification. Part 1. The Framework and modeling. *International Journal of Advanced Manufacturing Technology* , 827-835.

Kang, Y., Rong, Y., & Yang, J. C. (2003). Computer-aided fixture design verification. Part 2. Tolerance analysis. *The International Journal of Advanced Manufacturing Technology* , 836-841.

Kang, Y., Rong, Y., & Yang, J. C. (2003). Computer-aided fixture design verification. Part 3. Stability analysis. *International Journal of Advanced Manufacturing Technology* , 842-849.

Kaya, N. (2006). Machining fixture locating and clamping position optimization using genetic algorithms. *Computers in Industry* , 112-120.

Kolodner, J. (1993). *Case-Based Reasoning*. San Mateo: Morgan Kaufmann Publishers, Inc.

Krishnakumar, K., & Melkote, S. N. (2000). Machining fixture layout optimization using the genetic algorithm. *International Journal of Machine Tools* , 579-598.

Krishnakumar, K., Satyanarayana, S., & Melkote, S. N. (2002). Iterative fixture layout and clamping force optimization using the genetic algorithm. *Journal of Manufacturing Science and Engineering* , 119-125.

Leake, D. (1996). *Case-Based Reasoning*. Cambridge: The MIT Press.

Maher, M. L., Balachandran, M. B., & Zhang, D. M. *Cased-Based Reasoning In Design*. Mahwah: Lawrence Erlbaum Associates, Inc.

Mervyn, F., Kumar, A. S., & C., N. A. (2005). An adaptive Fixture Design System for Integrated Product and Process Design. *International Conference on Automation Science and Engineering* , 87-92.

Mervyn, F., Kumar, A. S., & C., N. A. (2005). Automated synthesis of modular fixture designs using an evolutionary search algorithm. *International Journal of Production Research* , 5047-5070.

Peterson Jig and Fixture. (2007). *Peterson Jig and Fixture*. Retrieved April 28, 2009, from PJF: <http://www.pjfinc.com/steel.htm>

Ratchev, S., Phuah, K., & Liu, S. (2007). FEA-based methodology for the prediction of part-fixture behaviour and its applications. *Journal of Material Processing technology* , 260-264.

Romheld Australia. (2007). *Modular Fixture Parts*. Retrieved December 9, 2007, from Romheld Australia: <http://images.google.com/imgres?imgurl=http://www.romheld.com.au/UserFiles/Image/Flexible%2520>

Fixture%2520Parts%2520(228%2520x%2520250).jpg&imgrefurl=http://www.romheld.com.au/sub\_products.php%3Fcat\_id%3D97%26cat\_name%3DModular%2BFixture%2BParts&h=250&w=2

Rong, Y., & Zhu, Y. (1999). *Computer-Aided Fixture Design*. New York: Marcel Dekker, Inc.

Rong, Y., & Zhu, Y. (1999). *Computer-Aided Fixture Design*. New York, New York: Marcel Dekker, Inc.

Satyanarayana, S., & Melkote, S. N. (2004). Finite Element Modeling of a fixture-workpiece contacts: single contact modeling and experimental verification. *International Journal of Machine Tools and Manufacture* , 903-913.

Siebenaler, S. P., & Melkote, S. N. (2006). Prediction of workpiece deformation in a fixture system using the finite element method. *The International Journal of Machine Tools and Manufacture* , 51-58.

Subramaniam, V., Kumar, A. S., & Seow, K. C. (2001). A multi-agent approach to fixture design. *Journal of Intelligent Manufacturing* , 31-42.

Wallack, A. S. (1996). Generic Fixture Design Algorithm for minimal modular fixture toolkits. *Proceedings of the 1996 IEEE International Conference on Robotics and Automation*, (pp. 487-495). Minneapolis.

Wang, H., & Rong, Y. (. (2008). Case Based Reasoning Method for Computer Aided Welding Fixture Design. *Computer-Aided Design* 40 , 1121-1132.

Woojin Engineering Co., Ltd. (2003, December 25). *Woojin Engineering*. Retrieved April 30, 2009, from Woojin Engineering: <http://www.wojinmc.com/html/>

Wu, Y., Rong, Y., Ma, W., & LeClair, S. (1998). Automated modular fixture planning: Accuracy, clamping, and accessibility analyses. *Robotics and Computer-Integrated Manufacturing* 14 , 17-26.

Yuru, Z., & Gaoliang, P. (n.d.).

Zheng, Y., Rong, Y., & Hou, Z. (2008). The study of fixture stiffness. Part II: contact stiffness identification between fixture components. *The International Journal of Advanced Manufacturing Technology* , 19-31.

Zheng, Y., Rong, Y., & Z, H. (2008). The study of fixture stiffness. Part I: a finite element analysis for stiffness of fixture units. *The International Journal of Advanced Manufacturing Technology* , 865-876.



## Appendix A. XML representation of a sample fixturing solution

```

_ <FDSetup Name="Setup 1" Filepath="\Setup 1.prt">
_ <WorkPiece>
  <WorkPiece Filepath="\case_2_asm_stp(0).prt" IndexInAssembly="1" />
  </WorkPiece>
_ <WorkTable Name="WorkTable" ID="WorkTable" Filepath="\WorkTable.prt" ImageFilepath="">
  <Function>7</Function>
  <FunctionalHeight MinValue="0.0000" MaxValue="0.0000" />
_ <Components>
_ <Comp Name="FT-D28-01001-001B" ID="FT-D28-01001-001B" FilePath="\D28-01001-001B(0).prt"
  XMLFilePath="\FT-D28-01001-001B.xml">
  <IndexInAssembly>1</IndexInAssembly>
  </Comp>
  </Components>
  <AssemblyConstraints />
_ <FeaturesGroup Type="SupportingFeatures">
_ <FixturingFace Function="5" Name="503-D28-01001-001B" FaceType="UF_ASSEM_planar_face"
  ComponentIndex="1">
_ <HoleFeatures>
_ <HolesPattern>
_ <OriginalHole Name="">
  <X>-450.000000</X>
  <Y>0.000000</Y>
  <Z>-450.000000</Z>
  </OriginalHole>
_ <Dir_Numbers>
  <X_dir>9.000000</X_dir>
  <Y_dir>0.000000</Y_dir>
  <Z_dir>9.000000</Z_dir>
  </Dir_Numbers>
_ <Dir_Offsets>
  <X_dir>100.000000</X_dir>

```

```

<Y_dir>0.000000</Y_dir>
<Z_dir>100.000000</Z_dir>
  </Dir_Offsets>
  </HolesPattern>
= <HolesPattern>
= <OriginalHole Name="">
  <X>-400.000000</X>
  <Y>0.000000</Y>
  <Z>-400.000000</Z>
  </OriginalHole>
= <Dir_Numbers>
  <X_dir>8.000000</X_dir>
  <Y_dir>0.000000</Y_dir>
  <Z_dir>8.000000</Z_dir>
  </Dir_Numbers>
= <Dir_Offsets>
  <X_dir>100.000000</X_dir>
  <Y_dir>0.000000</Y_dir>
  <Z_dir>100.000000</Z_dir>
  </Dir_Offsets>
  </HolesPattern>
  </HoleFeatures>
  <SlotFeatures />
= <CenterPoint Name="">
  <X />
  <Y />
  <Z />
  </CenterPoint>
  </FixturingFace>
  </FeaturesGroup>
  </WorkTable>
= <WorkingPoints>

```

```

_ <SideLocatingPoints>
_ <FixturingPoint Name="SideLocating Point 0">
  <PointUV>0.0278 -0.0003</PointUV>
  <PointOnFace>CAMFD SideLocatingFace 0</PointOnFace>
  <PointOnPart>case_2_asm_stp</PointOnPart>
  <FixtureUnit />
  </FixturingPoint>
_ <FixturingPoint Name="SideLocating Point 1">
  <PointUV>0.0584 0.1673</PointUV>
  <PointOnFace>CAMFD SideLocatingFace 1</PointOnFace>
  <PointOnPart>case_2_asm_stp</PointOnPart>
  <FixtureUnit />
  </FixturingPoint>
</SideLocatingPoints>
_ <BottomLocatingPoints>
_ <FixturingPoint Name="BottomLocating Point 0">
  <PointUV>3.0933 0.1642</PointUV>
  <PointOnFace>CAMFD BottomLocatingFace 0</PointOnFace>
  <PointOnPart>case_2_asm_stp</PointOnPart>
  <FixtureUnit />
  </FixturingPoint>
_ <FixturingPoint Name="BottomLocating Point 1">
  <PointUV>3.1473 0.0375</PointUV>
  <PointOnFace>CAMFD BottomLocatingFace 1</PointOnFace>
  <PointOnPart>case_2_asm_stp</PointOnPart>
  <FixtureUnit />
  </FixturingPoint>
_ <FixturingPoint Name="BottomLocating Point 2">
  <PointUV>3.1359 0.0375</PointUV>
  <PointOnFace>CAMFD BottomLocatingFace 2</PointOnFace>
  <PointOnPart>case_2_asm_stp</PointOnPart>
  <FixtureUnit />

```

```

    </FixturingPoint>
  </BottomLocatingPoints>
<SideClampingPoints>
  <FixturingPoint Name="SideClamping Point 0">
    <PointUV>-0.0276 -0.0001</PointUV>
    <PointOnFace>CAMFD SideClampingFace 0</PointOnFace>
    <PointOnPart>case_2_asm_stp</PointOnPart>
    <FixtureUnit />
  </FixturingPoint>
  <FixturingPoint Name="SideClamping Point 1">
    <PointUV>0.0701 0.1633</PointUV>
    <PointOnFace>CAMFD SideClampingFace 1</PointOnFace>
    <PointOnPart>case_2_asm_stp</PointOnPart>
    <FixtureUnit />
  </FixturingPoint>
</SideClampingPoints>
<TopClampingPoints />
</WorkingPoints>
<FixtureSolution />
<AssemblySimulation />
</FDSetup>

```