

# **Standalone Webcams in Glacier National Park**



**Justin Aquilante**

**Darius Boston**

**Connor Buek**

**Jacob Hazerjian**

**Peter Way**

# **Standalone Webcams in Glacier National Park**

**An Interactive Qualifying Project  
submitted to the Faculty of  
WORCESTER POLYTECHNIC INSTITUTE  
in partial fulfilment of the requirements for the  
degree of Bachelor of Science**

by

**Justin Aquilante**

**Darius Boston**

**Connor Buek**

**Jacob Hazerjian**

**Peter Way**

**Date:**

**11 October 2019**

**Report Submitted to:**

**Professor Frederick Bianchi  
Worcester Polytechnic Institute**

*This report represents work of WPI undergraduate students submitted to the faculty as evidence of a degree requirement. WPI routinely publishes these reports on its web site without editorial or peer review. For more information about the projects program at WPI, see*

*<http://www.wpi.edu/Academics/Projects>*

## **ABSTRACT**

The team worked with the Crown of the Continent Research Learning Center (CCRLC), at Glacier National Park, to address traffic congestion using webcams. Two webcams were developed: a solar-powered stationary webcam and a GPS mobile webcam. The webcams were built using Raspberry Pis and connected to the internet with cellular antennas. Because the webcams relied on cellular service, it was necessary to develop a cellular heatmap. Finally, a website was designed to display the images that the webcams captured.

## **ACKNOWLEDGEMENTS**

We want to thank a few people who made this project possible. Antonio Guerrero, a Verizon employee, went above and beyond trying to help us activate our devices on the Verizon network. We would also like to thank Nicholas Hollander of the 2019 WPI Acadia Webcam Team, who delivered swift and effective technical support regarding the static webcam he designed. This project would not have been possible without our liaisons, Tara Carolin and Mary Riddle, who provided support and guidance at the beginning of our project. Finally, we would like to thank Dr. Balistreri and Professor Bianchi, who worked closely with us during ID2050 and PQP. This project would not be what it is today without their help.



## AUTHORSHIP PAGE

Section	Primary Author	Editors
Abstract	Justin Aquilante	Connor Buek, Daraius Boston, Jacob Hazerjian, Peter Way
Acknowledgements	Peter Way, Daraius Boston	Connor Buek, Jacob Hazerjian, Justin Aquilante
Authorship Page	Connor Buek, Jacob Hazerjian	Daraius Boston, Peter Way, Justin Aquilante
Executive Summary	Daraius Boston	Connor Buek, Justin Aquilante, Jacob Hazerjian, Peter Way
1. Introduction	Connor Buek, Justin Aquilante	Daraius Boston, Jacob Hazerjian, Peter Way
2. Background	Peter Way	Connor Buek, Daraius Boston, Jacob Hazerjian, Justin Aquilante
2.1 The National Park Service	Peter Way	Connor Buek, Daraius Boston, Jacob Hazerjian, Justin Aquilante
2.2 Glacier National Park	Jacob Hazerjian	Connor Buek, Daraius Boston, Peter Way, Justin Aquilante
2.3 Traffic Congestion	Connor Buek	Peter Way, Daraius Boston, Jacob Hazerjian, Justin Aquilante
2.4 Traffic Congestion in Glacier National Park	Peter Way	Connor Buek, Daraius Boston, Jacob Hazerjian, Justin Aquilante

2.5 Glacier National Park Shuttle System	Daraius Boston	Connor Buek, Peter Way, Jacob Hazerjian, Justin Aquilante
2.6 Glacier National Park - Going to the Sun Management Plan	Daraius Boston	Connor Buek, Peter Way, Jacob Hazerjian, Justin Aquilante
2.7 Related Project Overview	Connor Buek	Peter Way, Daraius Boston, Jacob Hazerjian, Justin Aquilante
2.7.1 Previous IQP Projects	Connor Buek	Peter Way, Daraius Boston, Jacob Hazerjian, Justin Aquilante
2.7.2 Existing Webcams in Glacier National Park	Peter Way	Connor Buek, Daraius Boston, Jacob Hazerjian, Justin Aquilante
2.8 Raspberry Pi Webcams	Justin Aquilante	Connor Buek, Daraius Boston, Jacob Hazerjian, Peter Way
2.9 Cellular Networks	Daraius Boston	Connor Buek, Peter Way, Jacob Hazerjian, Justin Aquilante
3. Methodology	Connor Buek	Peter Way, Daraius Boston, Jacob Hazerjian, Justin Aquilante
3.1 Benchmarking	Peter Way	Connor Buek, Daraius Boston, Jacob Hazerjian, Justin Aquilante
3.2 Heatmap	Jacob Hazerjian	Connor Buek, Daraius Boston, Peter Way, Justin Aquilante
3.3 Verify the Concept of a Static-Solar Webcam System	Justin Aquilante	Connor Buek, Daraius Boston, Jacob Hazerjian, Peter Way
3.4 Implement and Test a Mobile Webcam	Justin Aquilante	Connor Buek, Daraius Boston,

System		Jacob Hazerjian, Peter Way
3.5 Design a Website to Display Data	Connor Buek	Peter Way, Daraius Boston, Jacob Hazerjian, Justin Aquilante
3.6 Quantitative Data Analysis	Daraius Boston	Connor Buek, Peter Way, Jacob Hazerjian, Justin Aquilante
4. Results and Discussion	Peter Way	Connor Buek, Daraius Boston, Jacob Hazerjian, Justin Aquilante
4.1 Heatmap/Connectivity Results	Jacob Hazerjian	Connor Buek, Daraius Boston, Peter Way, Justin Aquilante
4.2 Static-Solar Webcam Results	Daraius Boston	Connor Buek, Peter Way, Jacob Hazerjian, Justin Aquilante
4.3 Mobile Webcam Result	Connor Buek	Peter Way, Daraius Boston, Jacob Hazerjian, Justin Aquilante
4.4 Quantitative Data Analysis	Connor Buek	Peter Way, Daraius Boston, Jacob Hazerjian, Justin Aquilante
4.5 Website	Justin Aquilante	Connor Buek, Daraius Boston, Jacob Hazerjian, Peter Way
5. Recommendations	Jacob Hazerjian	Connor Buek, Daraius Boston, Peter Way, Justin Aquilante
5.1 Heatmap Recommendation	Peter Way	Connor Buek, Daraius Boston, Jacob Hazerjian, Justin Aquilante
5.2 Static-Solar Webcam Recommendations	Connor Buek	Peter Way, Daraius Boston, Jacob Hazerjian, Justin

		Aquilante
5.3 Mobile Webcam Recommendations	Daraius Boston	Connor Buek, Peter Way, Jacob Hazerjian, Justin Aquilante
5.4 Website Recommendations	Daraius Boston	Connor Buek, Peter Way, Jacob Hazerjian, Justin Aquilante
6. Conclusion	Justin Aquilante	Connor Buek, Daraius Boston, Jacob Hazerjian, Peter Way
7. References	Peter Way	Connor Buek, Daraius Boston, Jacob Hazerjian, Justin Aquilante
8. Appendix	Connor Buek	Peter Way, Daraius Boston, Jacob Hazerjian, Justin Aquilante
8.1 Appendix A: Mobile Webcam Source Code	Jacob Hazerjian	Connor Buek, Daraius Boston, Peter Way, Justin Aquilante
8.2 Appendix B: Static-Solar Webcam Source Code	Jacob Hazerjian	Connor Buek, Daraius Boston, Peter Way, Justin Aquilante
8.3 Appendix C: Cost Analysis	Justin Aquilante	Connor Buek, Daraius Boston, Jacob Hazerjian, Peter Way
8.4 Appendix D: Space Analysis	Peter Way	Connor Buek, Daraius Boston, Jacob Hazerjian, Justin Aquilante

# Table of Contents

<b>ABSTRACT</b>	<b>2</b>
<b>ACKNOWLEDGEMENTS</b>	<b>3</b>
<b>AUTHORSHIP PAGE</b>	<b>4</b>
<b>Table of Contents</b>	<b>7</b>
<b>Table of Figures</b>	<b>10</b>
<b>Executive Summary</b>	<b>14</b>
<b>1. Introduction</b>	<b>23</b>
<b>2. Background</b>	<b>26</b>
2.1. The National Park Service	26
2.2. Glacier National Park	29
2.3. Traffic Congestion	38
2.4. Traffic Congestion in Glacier National Park	39
2.5. Glacier National Park Shuttle System	40
2.6. Glacier National Park - Going to the Sun Management Plan	41
2.7. Related Project Overview	43
2.7.1. Previous IQP Projects	43
2.7.2. Existing Webcams in Glacier National Park	44
2.8. Raspberry Pi Webcams	45
2.9. Cellular Networks	46
<b>3. Methodology</b>	<b>47</b>
3.1. Benchmarking	47
3.2. Heatmap	49
3.3. Verify the Concept of a Static-Solar Webcam System	51
3.4. Implement and Test a Mobile Webcam System	55
3.5. Design a Website to Display Data	60
3.5. Quantitative Data Analysis	62
<b>4. Results and Discussion</b>	<b>64</b>
4.1. Heatmap/Connectivity Results	64
4.2. Static-Solar Webcam Results	69
4.3. Mobile Webcam Result	73
4.4. Quantitative Data Analysis	75

	9
4.5 Website	79
<b>5. Recommendations</b>	<b>82</b>
5.1 Heatmap Recommendation	82
5.2 Static-Solar Webcam Recommendations	82
5.3 Mobile Webcam Recommendations	82
5.4 Website Recommendations	83
<b>6. Conclusion</b>	<b>84</b>
<b>7. References</b>	<b>85</b>
<b>8. Appendix</b>	<b>90</b>
8.1 Appendix A: Mobile Webcam Source Code	90
8.2 Appendix B: Static-Solar Webcam Source Code	94
8.3 Appendix C: Cost Analysis	96
8.4 Appendix D: Space Analysis	97

## Table of Figures

Figure	Page
Figure 1: Verizon Cell Tower Map	15
Figure 2: Verizon Heatmap and Key	15
Figure 3: Closeup of Static-Solar Webcam	16
Figure 4: Static-Solar Webcam Clear Weather	17
Figure 5: The Mobile Webcam	18
Figure 6: Taken by mobile webcam from right side of road	19
Figure 7: Front Page of Website	20
Figure 8: Conditions Page	21
Figure 9: Time and Date Dropdowns	22
Figure 10: Congestion in Glacier National Park	23
Figure 11: Going-to-the-Sun Road Map	24
Figure 12: National Park Service Logo	26
Figure 13: Blackfoot Indians	29
Figure 14: Map of Glacier National Park	31
Figure 15: Picture of Mountains	32
Figure 16: Grinnell Glacier	33
Figure 17: Weather Charts for Glacier National Park	35



Figure 18: Goat in Glacier National Park	36
Figure 19: Plants in Glacier National Park	37
Figure 20: Traffic at Logan Pass	40
Figure 21: Park Shuttle	41
Figure 22: NPS Analysis of GTSR	42
Figure 23: Lake McDonald Webcam	44
Figure 24: Raspberry Pi	45
Figure 25: Mount Rainier National Park Webcam Website	48
Figure 26: Cellular Connectivity Heatmap	49
Figure 27: T-mobile Cell Tower Map	50
Figure 28: AT&T Cell Tower Map	50
Figure 29: Verizon Cell Tower Map	51
Figure 30: Static-Solar Webcam in the Field	52
Figure 31: Solar Panel	52
Figure 32: Battery	53
Figure 33: Static-Solar Webcam	53
Figure 34: Diagram of Static-Solar Webcam Components	54
Figure 35: Static-Solar Setup Diagram	54
Figure 36: The Sixfab LTE Shield	56

Figure 37: LTE Antenna	56
Figure 38: GPS Antenna	57
Figure 39: Pi Camera	57
Figure 40: Quectel EC25-V	58
Figure 41: The Mobile Webcam	59
Figure 42: A Diagram of the Mobile Webcam	59
Figure 43: Mobile Webcam in Van	60
Figure 44: Glacier Hiking Trails Website	61
Figure 45: Quantitative Analysis Classification	62
Figure 46: Data Validation	63
Figure 47: External Factors	63
Figure 48: Verizon Heatmap and Key	64
Figure 49: Heatmap Arrow at First Half Lake McDonald	65
Figure 50: Heatmap Arrow at Second Half Lake McDonald	66
Figure 51: Heatmap No Connection to Logan Pass	67
Figure 52: Heatmap Saint Mary Lake Good Connection	68
Figure 53: Heatmap Cell Tower Great Connection	69
Figure 54: Saint Mary's Falls Parking Lot	70
Figure 55: Closeup of Static-Solar Webcam	71

Figure 56: Static-Solar Webcam Clear Weather	71
Figure 57: Static-Solar Webcam Rainy Weather	72
Figure 58: Static-Solar Webcam Empty Parking Lot	72
Figure 59: Static-Solar Webcam Overcast Weather	73
Figure 60: Mobile Webcam in van	74
Figure 61: Picture taken by mobile webcam from right side of road	74
Figure 62: Picture taken by mobile webcam from left side of road	75
Figure 63: Quantitative Data Analysis Static-Solar	76
Figure 64: Quantitative Data Analysis Mobile	78
Figure 65: Front Page of Website	79
Figure 66: Website Most Recent Picture	80
Figure 67: Full Screen Image	80
Figure 68: Time and Date Dropdowns	81

## Executive Summary

Glacier National Park visitation has increased over the past few years, causing traffic congestion which can affect visitor experience. In September 2019, Glacier National Park released a draft of the *Going to the Sun Road Corridor Management Plan Environmental Assessment*. One of the goals laid out in the plan was to “Develop a congestion app and mobile device friendly website using real time data” (nps, 2019). Our project works directly towards this goal through the implementation of standalone webcams. These webcams are able to provide real time traffic data in an effort to reduce traffic congestion in the park.

We explored new methods for traffic mitigation that Glacier had yet to investigate, opening up new avenues for traffic control and mitigation.

Our project goals were to:

- Create a cellular connectivity map of the Going to the Sun Road.
- Implement and test a static-solar webcam system.
- Implement and test a mobile webcam system.
- Research and develop a website that would display the data from the webcams.
- Evaluate the website and offer recommendations.

Our standalone webcams need cellular connectivity to function. Before we tested any of the webcams, a cellular heat map needed to be created. To make a heatmap we first determined which cellular provider was the strongest in the park. To determine this, we spoke to local experts and examined cell tower maps. Verizon turned out to be the strongest carrier in the park. After collecting GPS vs signal strength data for Verizon along the Going to the Sun Road, we generated a cellular heatmap:

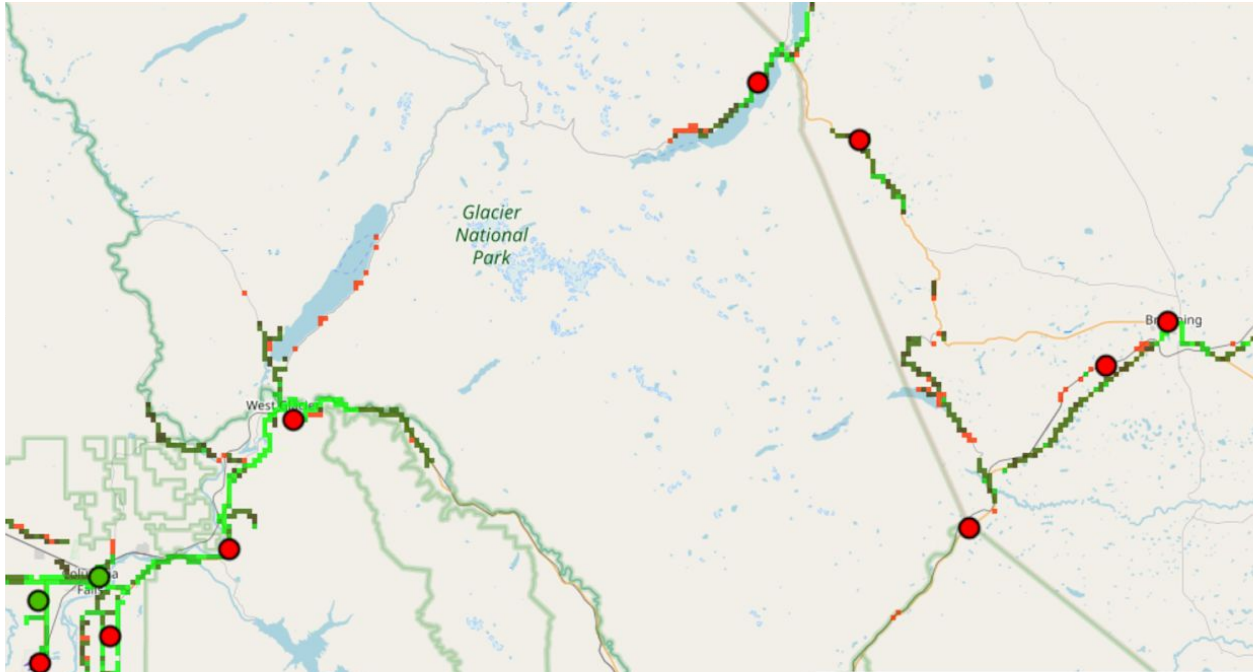

**Figure 1: Verizon Cell Tower Map**

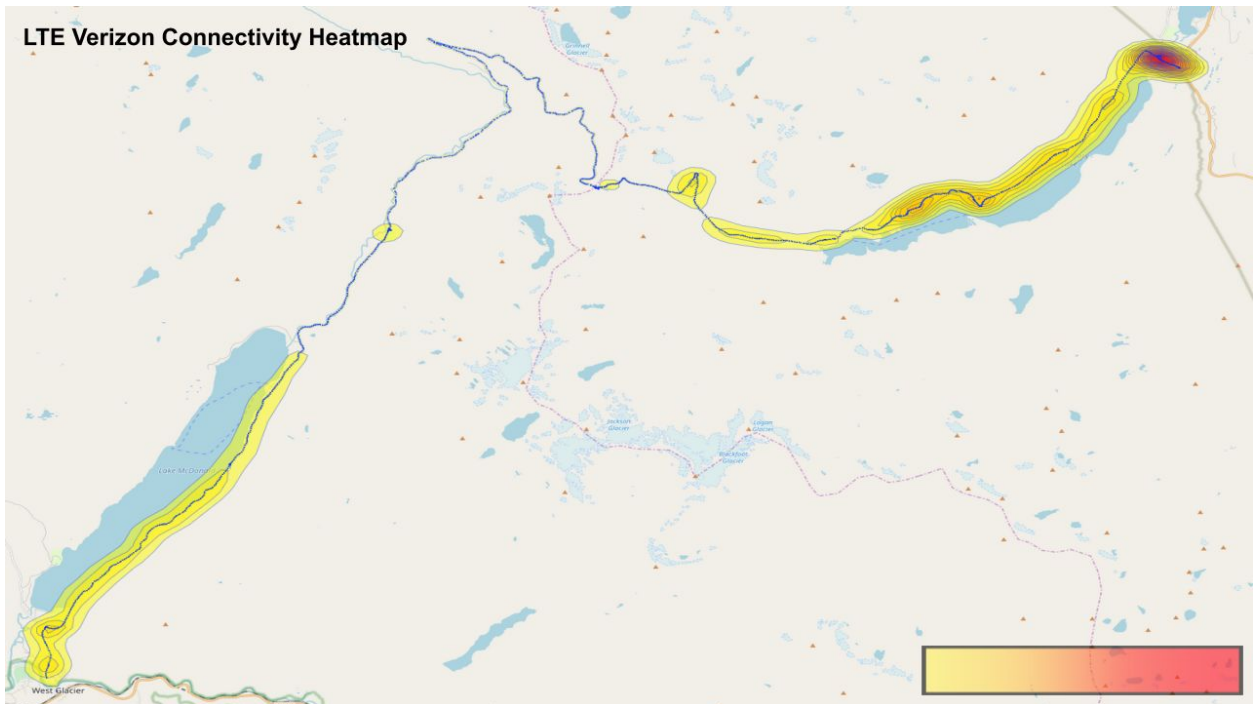

**Figure 2: Verizon Heatmap and Key**

We worked closely with the students from the 2019 WPI *Implementation and Design of Webcam Systems for Traffic Monitoring in Acadia National Park* team throughout the project. Working with the Acadia team we designed and developed a prototype static-solar webcam system alongside a mobile webcam system. Our focus was on the mobile webcam while the Acadia group focused on the static-solar webcam. The static-solar webcam was built with a Raspberry Pi 3, equipped with a camera module and a 4G LTE module. It was powered by a lead acid battery, which charges through a solar panel.



**Figure 3: Closeup of Static-Solar Webcam**

To test the static-solar webcam in the park, we deployed it at Mary's Fall parking lot. We chose this parking lot because it was in one of the zones we determined had sufficient service for a webcam system. The static-solar webcam was tested over four days at this location. During this time the webcam took a picture every two minutes during daylight hours. It captured 1680 images and uploaded them to a server through cellular service.



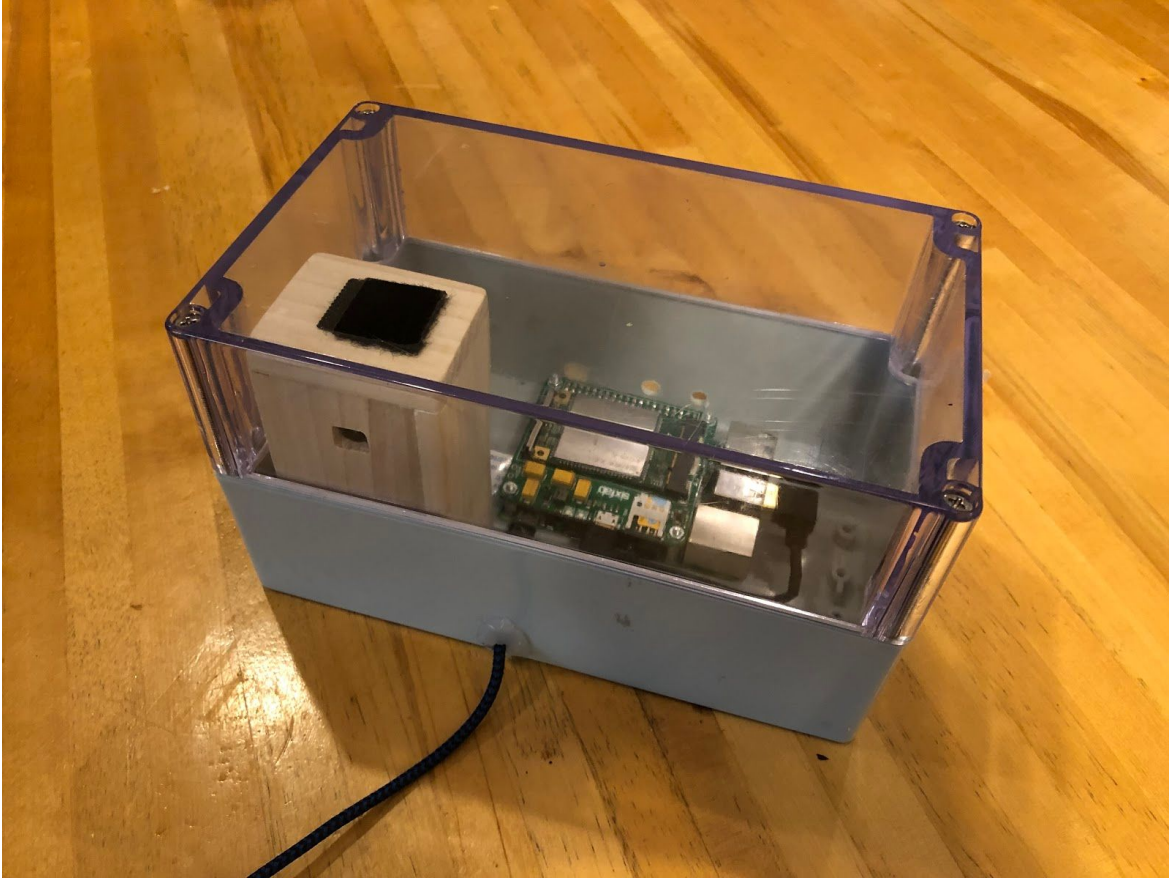

**Figure 4: Static-Solar Webcam Clear Weather**

The mobile webcam consists of most of the same hardware as the static-solar webcam. However it has an added GPS antenna and instead of a battery/solar panel, it uses power provided from a vehicle. The criteria the mobile webcam had to meet were:

- Take high resolution images
- Upload high resolution images to a server
- Fit on the inside of a car without causing distraction
- GPS compatible
- Onboard storage for multiple high resolution images
- Operate and take pictures autonomously
- Function from power supplied by a vehicle





**Figure 5: The Mobile Webcam**

To prep the webcam for testing, the team drove the length of the Going to the Sun Road and logged GPS coordinates, creating a database of pull-offs and parking lots. Once the mobile webcam had GPS coordinates, it took pictures at specified locations. The webcam was then able to upload pictures to the server once the Raspberry Pi had a cellular connection. Due to the lack of cellular service at some locations, there was some lag time between pictures being taken and uploaded. Connection is lost soon after Lake McDonald when coming from the west and a few miles after passing Saint Mary Lake from the east. Both sets of shuttles have their last stops at Logan Pass, making it a maximum of an hour lag for the shuttles coming from West Glacier and about a thirty minute lag time for the shuttles coming from Saint Mary.



**Figure 6: Taken by mobile webcam from right side of road**

The website was created with the intention of providing parking information and traffic conditions to visitors and the park employees in real time. It was aimed to be clear and easy to use while accurately depicting where in the park the pictures were taken. The static and mobile webcams both hooked up to the website and the pictures were sorted into their respective locations.

The criteria needed for the website to give visitors the best options for planning include:

- Ease of navigation
- Compatible with the Glacier National Park website
- Effectively display where images were captured
- Clearly display images
- Archive of past images

The front page of the website consisted of the interactive map of the Going to the Sun Road with hyperlink icons linked to corresponding parking lots and pull-offs. The icons distinguish between parking lots and pull-offs alongside the road.

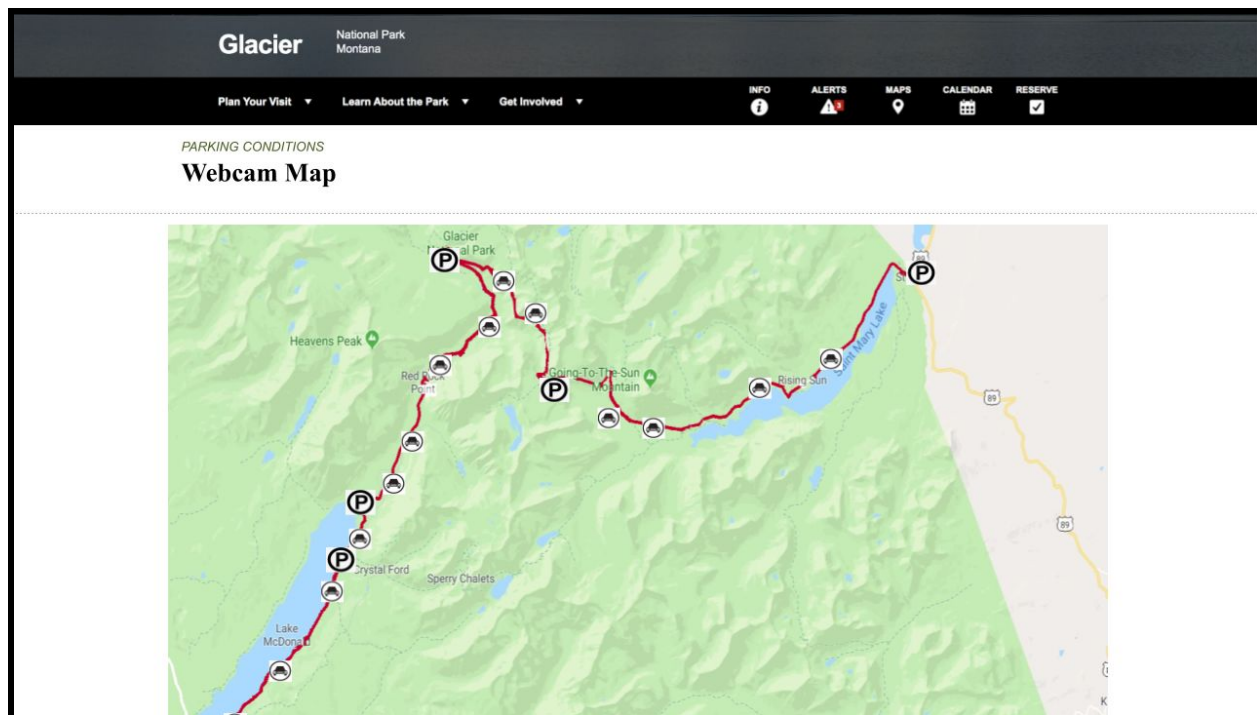

**Figure 7: Front Page of Website**

To see the parking conditions on the road, one can hover the mouse over an icon and it will give the name of the parking spot. Clicking the icon will bring you to the current parking conditions for the spot chosen. There is also an in depth archive system which allows visitors and park employees to view any pictures taken in the past. There are options to go to the previous picture, the next picture, as well as take them back or forward 24 hours.

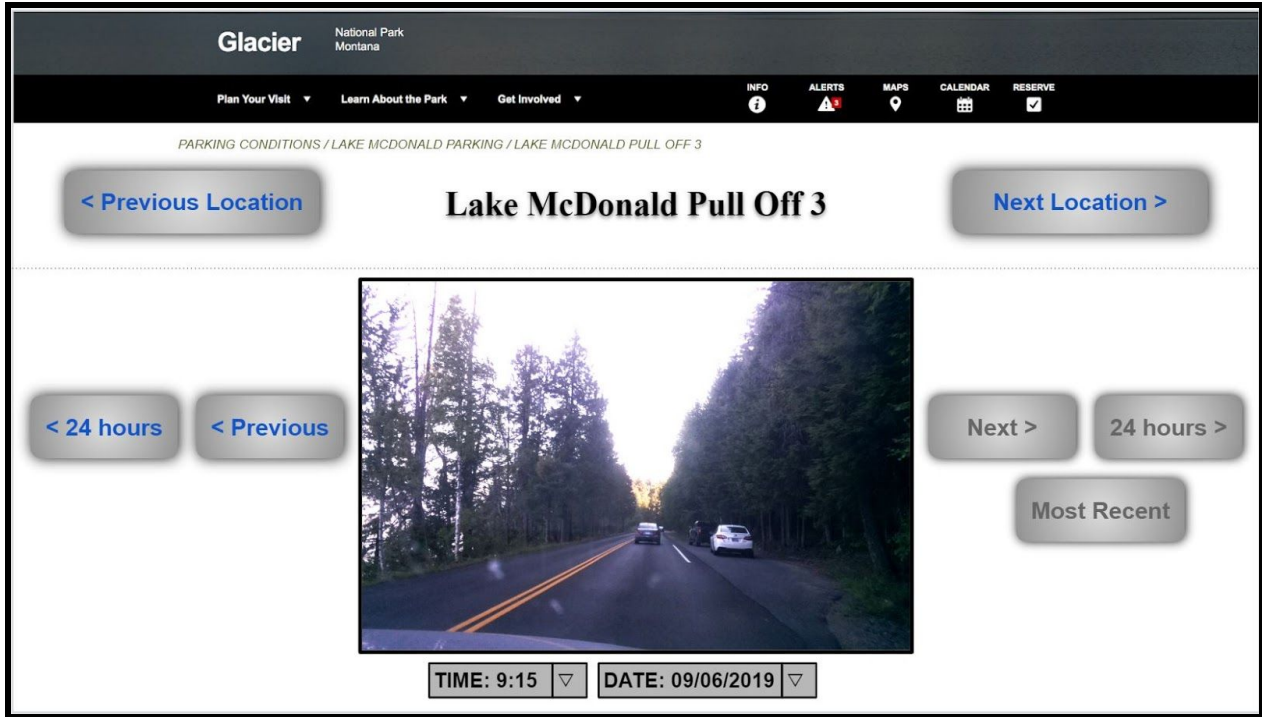

**Figure 8: Conditions Page**

They also have the option to go directly to the current conditions from whatever date and time they are viewing. If users want to see a specific time from the previous day, or had a particular week they wanted to view from a previous year, the drop down time and date menus provide an easy way to move through the archive.

EXPERIENCE YOUR AMERICA™

ACCESSIBILITY | PRIVACY POLICY | FOIA | NOTICES | DISCLAIMER  
FAQ | NO FEAR ACT | CONTACT US | USA.GOV

National Park Service  
U.S. Department of the Interior

Figure 9: Time and Date Dropdowns



## 1. Introduction

The population of the United States has been rapidly increasing (World Population Review, 2019). Higher populations have begun to cause human and vehicle congestion across the country. National parks, in particular, have been greatly impacted by rising populations and are seeing a great increase in visitors (nps, 2018). Increasing visitors are causing new problems in many national parks such as full parking lots and busy roadways. These congestion problems can have an affect on the visitor experience in the parks (Gardner, 2019). Rising congestion and human activity also increases the risk of change to the ecosystem in the parks. (nps, 2016). The National Park Service is looking to solve these new congestion problems without harming the natural environment or limiting visitor opportunities (nps, 2014).

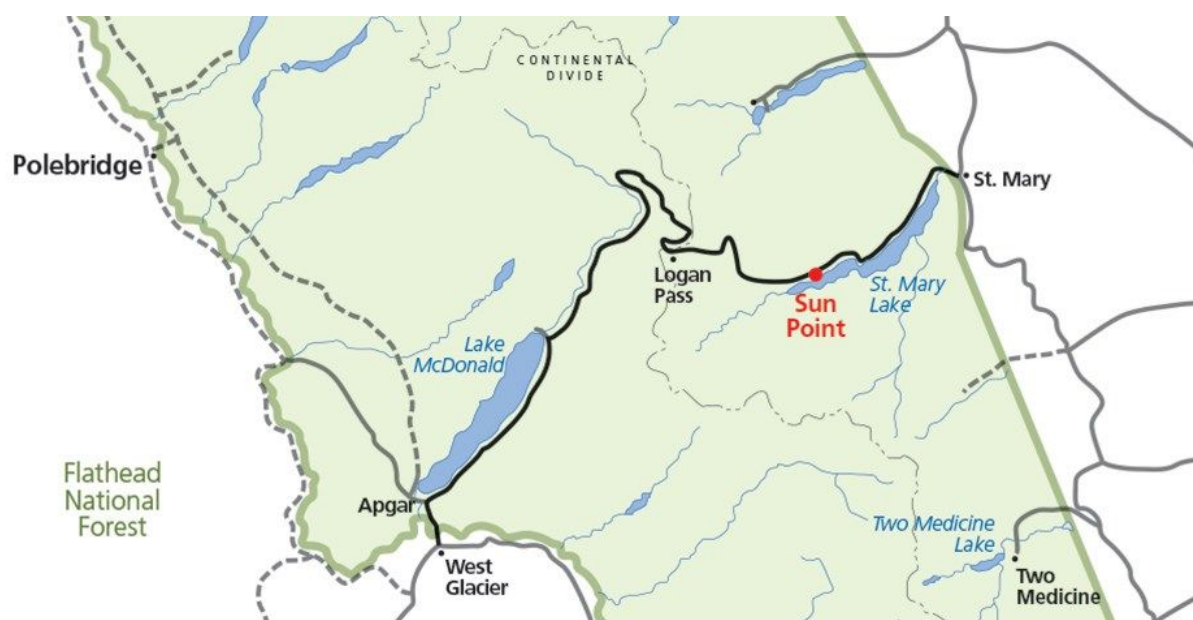

**Figure 10: Congestion in Glacier National Park**

Source: GlacierNPS. (2018, July 19). Free Shuttle at Logan Pass.

Glacier National Park has been one of the parks affected by traffic congestion. The park has difficulty managing all the visitors coming into the park, which has led to massive backups as visitor vehicles fill roads and overflow parking lots (Lamon, 2018). Another side effect of the larger visitation numbers is the increased amount of noise and air pollution (nps, 2016). The increase in pollution can then contribute to the decrease in wildlife population sizes (nps, 2016). Glacier National Park is looking to solve the issue of congestion to reduce the impact on the environment and maintain the visitor experience (nps, 2019).

In Glacier National Park, the Going-to-the-Sun Road, a highway which extends through the entire park, is the primary method of travel for visitors.



**Figure 11: Going-to-the-Sun Road Map**

Source: NPS. (2019, April 12). Going-to-the-Sun Road Celebration.

As this is the only main road in and out of the park, traffic backups are common (nps, 2014). Visitors also often pull over to the side of the road to enjoy the views or to watch wildlife, resulting in additional traffic backups (Gardner, 2019). Once visitors arrive at their destinations in the park (visitor centers, hotels, campgrounds), parking spots are not guaranteed. Parking lots can fill up as early as 8:30 a.m. Visitors have limited options for gauging the availability of spots



in the park before arriving and often go to parking areas that are already full. This results in visitors circling around parking lots and looking for spaces (Friesen, 2019). If visitors had access to data on parking lots and availability of parking spots, before making the trip, it could help visitors plan better and cut down on traffic congestion.

In Glacier National Park, a 2018 WPI research team explored new ways to address the traffic congestion problem. The current methods used in the park, such as vehicle size restrictions, hiring additional staff, increasing signage, and simply closing routes, are antiquated and are becoming inadequate for modern visitor traffic (nps, 2019). We explored new methods for traffic mitigation that Glacier had yet to investigate, opening up new avenues for traffic control and mitigation.

Our project goals were:

- Create a cellular connectivity map of the Going to the Sun Road
- Implement and test static-solar webcam system.
- Implement and test a mobile webcam system.
- Research and develop a website that will display the data from the webcams.
- Evaluate the website and offer recommendations.

## 2. Background

### 2.1. The National Park Service

The National Park Service (NPS) is an agency of the U.S. Department of the Interior. It manages several hundred designated properties of the federal government, including national parks, monuments, and historic sites.



**Figure 12: National Park Service Logo**

Source: Wikipedia contributors. (2019, October 6). National Park Service. In Wikipedia, The Free Encyclopedia.

President Woodrow Wilson signed The Organic Act in 1916, creating the National Park Service so that it would “conserve the scenery and the natural and historic objects and the

wildlife therein and...leave them unimpaired for the enjoyment of future generations.” In 1872, following an expedition sponsored by the U.S. Geological Survey, Congress authorized the creation of Yellowstone Park as the country’s first national park (Britannica, n.d.).

Naturalists such as John Muir were concerned that the national parks were not being preserved properly (Britannica, n.d.). Muir stated his case to outdoor enthusiast President Theodore Roosevelt when the two of them camped together in Yosemite. In the Antiquities Act of 1906, the president was given power to preserve such government lands (Britannica, n.d.). Over the next 10 years, more than 30 monuments were proclaimed. While these parks were officially managed by the Department of the Interior, they were also managed by different entities including the U.S. Army. As a result, the exploitation of resources in park locations continued. Stephen Mather wrote to the Secretary of the Interior in 1914 about the poor condition of the national parks and was enlisted to improve and unify the system (Britannica, n.d.). In 1916, he became the first director of the NPS, organized by the Organic Act (Britannica, n.d.). Mather and his assistant Horace Albright created a professionalized NPS corps of rangers and established over a dozen national parks between 1916 and 1933 (Britannica, n.d.).

Today, the NPS runs over 400 sites and employs over 20,000 people across the United States (National Park Service[nps], 2016b). Its mission statement reads: “As the steward of 418 park units, 23 national scenic and national historic trails, and 60 wild and scenic rivers, the NPS is charged with conserving these lands and historic features that were designated for their cultural and historic significance, scenic and environmental attributes, and educational and recreational opportunities. Additionally, the NPS further helps the nation protect resources for public enjoyment that are not part of the National Park System through its financial and technical assistance programs” (nps, 2016b).

For a park to be considered a national park, it must have significant natural, cultural, or recreational resources (nps, n.d.). It also must be a beneficial addition to the National Park System. The Organic Act, passed on August 25, 1916, defined this criteria. It established the National Park Service sector of the Department of the Interior, which is in charge of all National Parks, historical areas, and monuments that have been designated as federal lands. From the

founding of Yellowstone National Park in 1872 until the passing of the Organic Act 44 years later, the Department of the Interior managed national parks while the War Department and the Forest Service administered historical areas and monuments (Cullinane, 1997).

Although the park service budget has been cut over the past five years, visitors have provided \$32 billion in economic activity. The National Park Conservation Association (NPCA) estimates that for every dollar that is spent on the National Park Service, the economy benefits 10 dollars from it (NPCA, 2015). Congress doesn't see the economic benefits of the National Parks as the National Park Service's budget continues to be cut each year. Record-breaking visitation rates across many national parks have harshly impacted the parks as they have reduced funds to pay for additional staff (NPCS, 2015). Currently, national parks in the US have a backlog in repairs of nearly 12 billion dollars (NPCS, 2015). The cost of repairs will continue to rise as the number of visitors continues to increase.

National parks also promote economic growth in "gateway communities", or communities located within 60 miles of a park (Cullinane, 1997). A report published in 2017 stated that visitors to national parks spent an estimated \$18.2 billion in gateway communities, supporting over 306,000 jobs (Cullinane, 1997). This added \$35.8 billion in economic output to the national economy (Cullinane, 1997).

## 2.2. Glacier National Park



**Figure 13: Blackfoot Indians**

Source: File: Three chiefs Piegan p.39 horizontal.png. (2019, August 11). Wikimedia Commons, the free media repository.

Glacier National Park's mountainous region was first inhabited by the Blackfeet, Salish, and Kootenai Native Americans over 10,000 years ago. It was later explored by the French, English and Spanish in search of the beaver during the early 1800's (nps, 2016a). The tribes in the northwest Montana region relied on the natural resources of the area. During the winter months, women and children dug for roots in the mountains while hunters sought after bison. This would continue until the annual Sun Dance celebration during the summer months. Europeans began migrating to the region in the early 1800's in search of pelts, and they were soon followed by miners and other settlers. In 1891, the Great Northern Railway was completed, allowing more settlers into the area who began to form small towns in the valleys. Though most people would venture out to northeast Montana in search of a source of income, people started to

appreciate the natural aesthetic of the land and began traveling to the region for that reason alone (nps, 2016a).

Influencers like George Bird Grinnell began to push for the creation of a national park in northwest Montana. Thanks to the efforts of Grinnell and his fellow influencers, President Taft decided to sign a bill establishing Glacier National Park on May 11, 1910. Twenty-two years later, in 1932, Glacier National Park joined the neighboring Waterton Lakes National Park (A Canadian park founded in 1895) to becoming the world's first International Peace Park (National Geographic, 2019). A peace park is a protected area that has a special focus on creating or maintaining peace inside its borders. Although Glacier and Waterton Lakes are considered one peace park, the two are still managed separately, however, they often coordinate on topics such as wildlife management, scientific research, and visitor attractions.

Glacier National Park is 1,583 square miles, making it the 12th largest national park in the United States (nps, 2018). Glacier National Park has an incredibly diverse topography. The park has over 150 mountains, the tallest of which reaches 10,466 feet above sea level. The lowest point in the park is over 7,000 ft lower than the highest point at 3,215 ft above sea level (nps, 2018).



**Figure 14: Map of Glacier National Park**



Source: NPS. (2019, October 7). Glacier National Park Webcams.

Mountains in Glacier National Park are part of the Rocky Mountains. There are at least 150 named mountain peaks in the three ranges in the park: Clark, Lewis, and Livingston. Mount Cleveland, elevation 10,466 feet, is the highest mountain in the park.

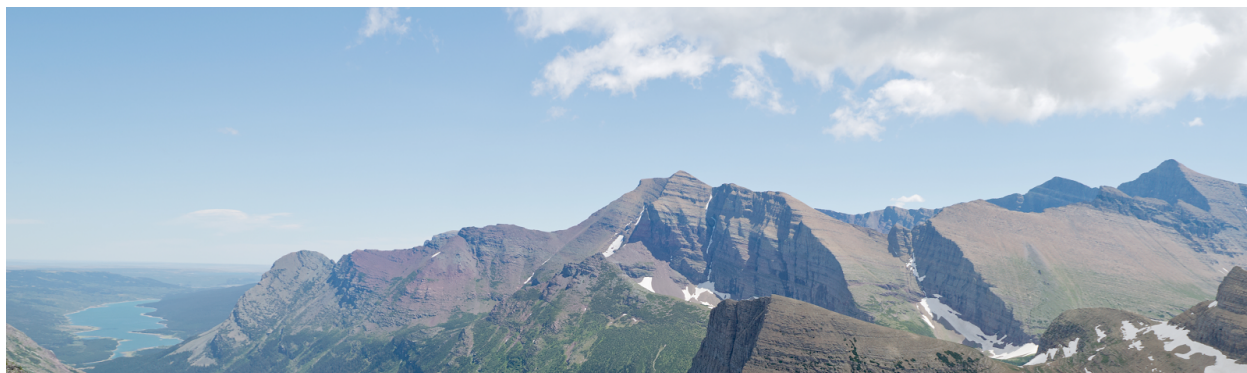

**Figure 15: Picture of Mountains**

In Glacier National Park there are 762 lakes, and 131 of those lakes are named. There are 563 streams running to and from the lakes (nps, 2016). Generally, the water quality in Glacier National Park is very high, classified as A1, meaning it is the highest quality water recognized by the state (nps, 2016). The high quality water is resulted from flowing from the tops of mountains to the rest of the streams in the park. When glaciers move, they grind the stone beneath them into

a fine powder. This powder is then carried to the lakes, where it appears turquoise in color, an effect from the powder being absorbed into the water and exposed to sunlight (nps, 2016). Areas where this could occur, according to the NPS (2016), include Lakes St. Mary and Swift Current. However, pollution caused by outside sources such as polluted rain and snow can cause a drop in quality.

A glacier is a mass of snow, ice, and rock. To be considered an active glacier, the ice must cover an area of at least 25 acres.



**Figure 16: Grinnell Glacier**

Source: File:Grinnell Glacier Overlook at Glacier National Park, MT (DSC 0597).jpg.  
(2019, March 12). Wikimedia Commons, the free media repository.

When the ice is smaller than 25 acres it becomes stagnant, and is called an inactive glacier. Named after its vast glacier collection, Glacier National Park used to house 150 active glaciers in 1910 during its opening, but this number has since dropped to 26 (Grisak, 2018). The loss of those glaciers is due to the rising temperatures. This rise causes the ice to melt faster than it is replaced through snowfall. The glaciers in Glacier National Park are vital to the environment (Grisak, 2018). The water runoff from the glaciers feeds the rivers in the area. With fewer glaciers, rivers will run dry, causing a drastic shift in vegetation (Grisak, 2018).

Weather in Glacier National Park is highly variable and extreme at times, directly linked to its geographic location. Glacier sits on top of a continental divide that separates two opposing climates. The wet and warm air from the Pacific hits from the West, while the cold, dry Arctic

air hits Glacier from the Northeast. Due to the differing climates, the west side of the park experiences more rainfall than other parts of the park. The east side is usually less dry, with high winds that regularly reach 50mph. Warm winds often cause spring-like days that can raise the temperature by 30 degrees in a few minutes. Alternatively, cold winds can mix with the wet Pacific air and cause sudden and severe blizzards. Although the weather in Glacier National Park varies greatly over the course of the year, the park still experiences the four well-defined seasons of summer, fall, winter, and spring.

The average summertime temperature in Glacier is 80 degrees fahrenheit with occasional rain and winds expected. It is common for the temperature to be 80 degrees during the day, only to drop down to nearly 20 degrees at night (nps, 2018a). Fall in Glacier National Park usually brings colder weather and higher winds. Frequently, it snows as early as September in Glacier. Winter is the longest season in Glacier. Winters have an average temperature of 20-30 degrees. However, temperatures can reach as low as -40 degrees; high winds with these temperatures are common as well. There is an average snowfall of 157 inches in some parts of the park. Spring in Glacier National Park is often wet, as the warmer temperatures begin to melt the snow. Snow usually melts completely in most parts of the park by mid May. However, it's not uncommon for the park employees to still be removing snow in early June (nps, 2018a).

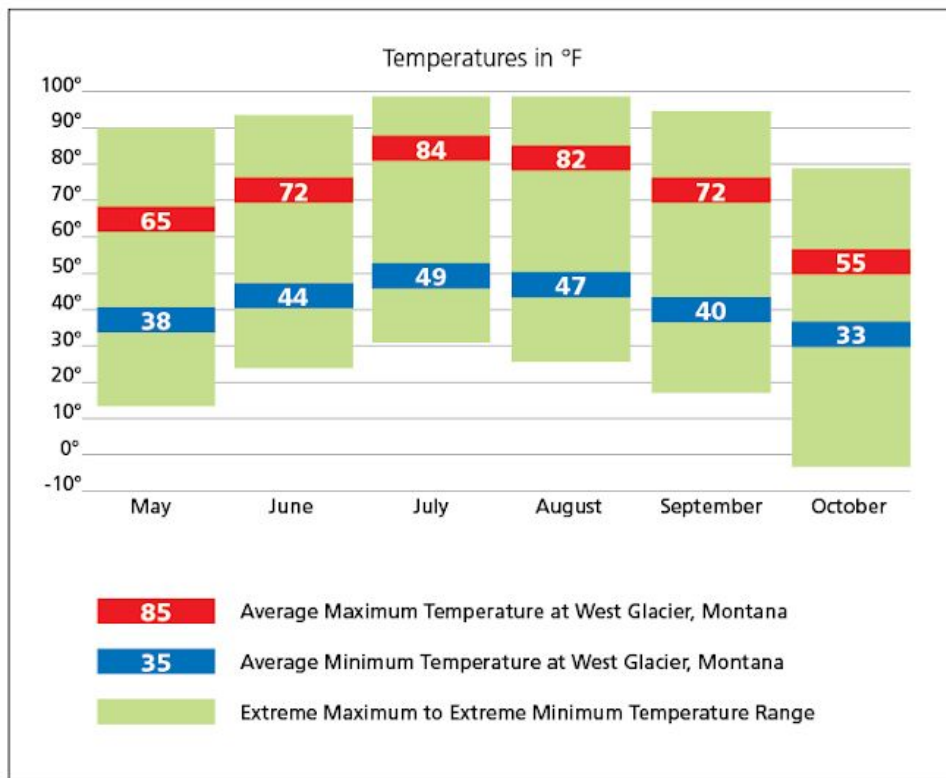

Precipitation in inches

Over 30 year period	January	February	March	April	May	June	July	August	September	October	November	December
Average	3.4	2.37	1.86	1.81	2.57	3.28	1.75	1.64	2.06	2.33	3.1	3.3
Low	0.16	0.33	0.43	0.27	0.91	0.75	0	0	0.02	0.08	0.65	0.68
High	7.07	5.1	4.13	3.45	6.13	6.94	5.11	5.14	6.17	5.87	7.53	7.72
Average Snowfall	39.6	22.5	14.5	3.5	0.4	0.2	0	0	0.1	2	17.2	37.5
Number of days with precipitation over 0.01 inches	17	13	13	17	17	17	17	17	17	17	17	17

**Figure 17: Weather Charts for Glacier National Park**

Source: nps, 2019

Glacier National Park is home to over 356 species of mammals, birds, amphibians, and reptiles (nps, 2016c). Additionally, many types of insect life reside in the park. The NPS reports



that there are so many types of insects that it would be impossible to try and count all of the species (nps, 2016c). They estimate that under any log in the park, there could be upwards of 20,000 species of insects (nps, 2016c). The preserved ecosystem in Glacier is a result of the park's early founding.



**Figure 18: Goat in Glacier National Park**

Source: Wikipedia contributors. (2019, October 1). Glacier National Park (U.S.). In Wikipedia, The Free Encyclopedia. Retrieved 15:24, October 7, 2019.

Plant life is also abundant in Glacier National Park, which contains about 1,132 types of vascular plants (nps, 2016c). These include grasses, ferns, trees, wildflowers, and mushrooms. There are 804 types of herbs also densely populated Glacier. Of these plants, 109 of them are considered sensitive, or endangered (nps, 2016c). Forest fires are also occasional in Glacier. All

aspects of nature benefit from fires. These fires contribute to diverse wildlife by releasing nutrients from what they burn.



**Figure 19: Plants in Glacier National Park**

Source: nps, 2016b

Hiking is one of the most popular visitor attractions in Glacier National Park. Over 50% of visitors reported taking a hike while visiting the park. There are over 700 miles of hiking trails (nps, 2018b). The variety of trails ensures hiking opportunities for all experience levels. The National Park Service offers a variety of resources for hikers looking to hike in Glacier National Park. The NPS keeps a detailed trail status report that is available to the public. This report allows hikers to see the status of trails so they can plan their hike before they arrive at the park. Glacier National Park also offers ranger-guided hikes for a more informational and safe hiking experience. Some of the most popular hikes in the park include the Highline Trail, Grinnell Glacier, Iceberg Lake, and Hidden Lake Overlook.

### **2.3. Traffic Congestion**

There are two types of congestion: recurring and non-recurring. Non-recurring congestion is caused by temporary disruptions, like flat tires and construction work. This is considered non-systematic and cannot be addressed as a whole. There are three types of non-recurring traffic congestion: incidents, roadwork, and weather (US Department of Transportation, 2017). Incidents include flat tires and car accidents, both of which cause traffic congestion. Road work has the same effect as traffic incidents, but road work can continue for weeks depending on the construction work being done. Weather has an unpredictable effect on traffic congestion due to its randomness. Traffic will slow down slightly during light rain, but during a snowstorm the traffic can come to a complete halt. All three of these non-recurring causes of congestion happen every day creating traffic congestion across the United States (US Department of Transportation, 2017).

The second type of congestion is recurring congestion. Recurring congestion is when there are more vehicles than the road system can accommodate. Recurring traffic results in longer commutes to and from work during rush hours. Rush hours are the time of day when traffic is heaviest and they have more than doubled in intensity and duration in the last 20 years (US Department of Transportation 2017). With increasing cars on the road, recurring traffic congestion will be a problem that continuously gets worse. Recurring congestion is systematic, thus system wide solutions can be developed to mitigate it.

Successful strategies to mitigate recurring congestion include reducing automobile use as well as creating new traffic lanes. Alternatives such as public transport can help to reduce the number of vehicles on the road therefore alleviating recurring congestion (Falcocchio, Levinson, 2015a). However, the best method to mitigate recurring congestion is to implement a combination of multiple mitigation strategies which has a greater effect than if they were implemented separately (Falcocchio, Levinson, 2015b).

As traffic congestion increases, so does its impact on the environment. Congestion causes more vehicles to sit in traffic and idle their engines which releases more emissions. Therefore,

the increase in traffic congestion has led to vehicles releasing more emissions which causes degradation of air quality in the areas surrounding roadways (Batterman, Zhang, 2013). Emissions are also a major contributor to climate change, which can disrupt the life and processes in ecosystems. Acid rain can also be caused by air pollution from vehicle emissions. Acid rain can increase the acidity of aquatic environments killing native fish and vegetation. A final impact of increased traffic congestion is the noise pollution created by cars, trucks, and especially motorcycles. Loud noises from congestion can alter the lives of many animals by driving them away from and destroying their natural habitats (Batterman, Zhang, 2013).

## **2.4. Traffic Congestion in Glacier National Park**

In Glacier National Park, the Going-to-the-Sun Road is the only highway that crosses through the park making it the main way of accessing locations in the park. The Going-to-the-Sun Road is a two lane highway, which some days has to accommodate the vehicle traffic of over 30,000 people, often has problems with bottlenecks that occur when a narrow road impedes traffic flow. The Going-to-the-Sun Road only has two lanes; one for each direction of travel, however, this two lane highway is not enough to accommodate the growing amount of vehicle traffic. Falcochio and Levinson (2015c) states that bottlenecks can occur due to driver behavior such as cars frequently parking illegally on the side of the road which further restricts traffic contributing to the creation of bottlenecks. Additionally, poor weather conditions can contribute to bottlenecks (Falcochio, Levinson, 2015c).

Parking lot backups along the Going-to-the-Sun Road contribute to congestion in the roadway. Parking lots are often backed up as the early morning rush of cars into the park can fill up the limited parking space by 8:30 am (nps.gov, 2018). This leads to people parking illegally throughout the park and increases congestion as people drive from the parking lot to parking lot in search of parking. In 2013, park officials started a multi-year planning effort to address traffic congestion issues. The planned solutions will focus on visitor use, traffic congestion, road operation and maintenance while protecting natural and cultural resources (nps, 2019).





**Figure 20: Traffic at Logan Pass**

Source: [volpe.dot.gov](http://volpe.dot.gov)

## **2.5. Glacier National Park Shuttle System**

In Glacier National Park, there is a free shuttle system that moves the visitors up and down the Going-to-the-Sun Road from the west side of the park. On the east side of the park, there is a shuttle system as well, but for a small price. During peak summer hours, July 1st to mid-September, the shuttles leave from the Apgar Visitor Center near the entrance of the park about every 30 minutes. The shuttles do slow down as more cars populate the road as the shuttles get stuck in vehicle traffic. This can delay the shuttles and throw off the shuttle schedule. The schedule also changes once school in the area starts as the shuttle drivers return to their full time school bus jobs. During September, the shuttles can take up to two hours to arrive at the Apgar Visitor Center, but there is no set schedule due to lack of drivers. The shuttles cease operations

each winter based on the conditions of the road, the number of drivers are available, and the amount of visitors still coming to the park.

There are six shuttle stops along the west side of Glacier National Park and nine shuttle stops along the east side. The stops are all at high-use locations along the Going-to-the-Sun Road, such as campsites, boat docks, lodges, and trail heads. The west side shuttles have a designated transfer stop at Avalanche Creek while the final stop for the west side and east side shuttles is Logan Pass (nps, 2016c).



**Figure 21: Park Shuttle**

Source: nps. 2019

## **2.6 Glacier National Park - Going to the Sun Management Plan**

During our project, Glacier National Park released a document detailing their plans for managing congestion on the Going-to-the-Sun Road. Potential strategies included an additional parking lot, a permit system, increased shuttle activity, and encouraging visitors to use bicycles.



The document analyzes the traffic issues along the Going-to-the-Sun Road in the following image:

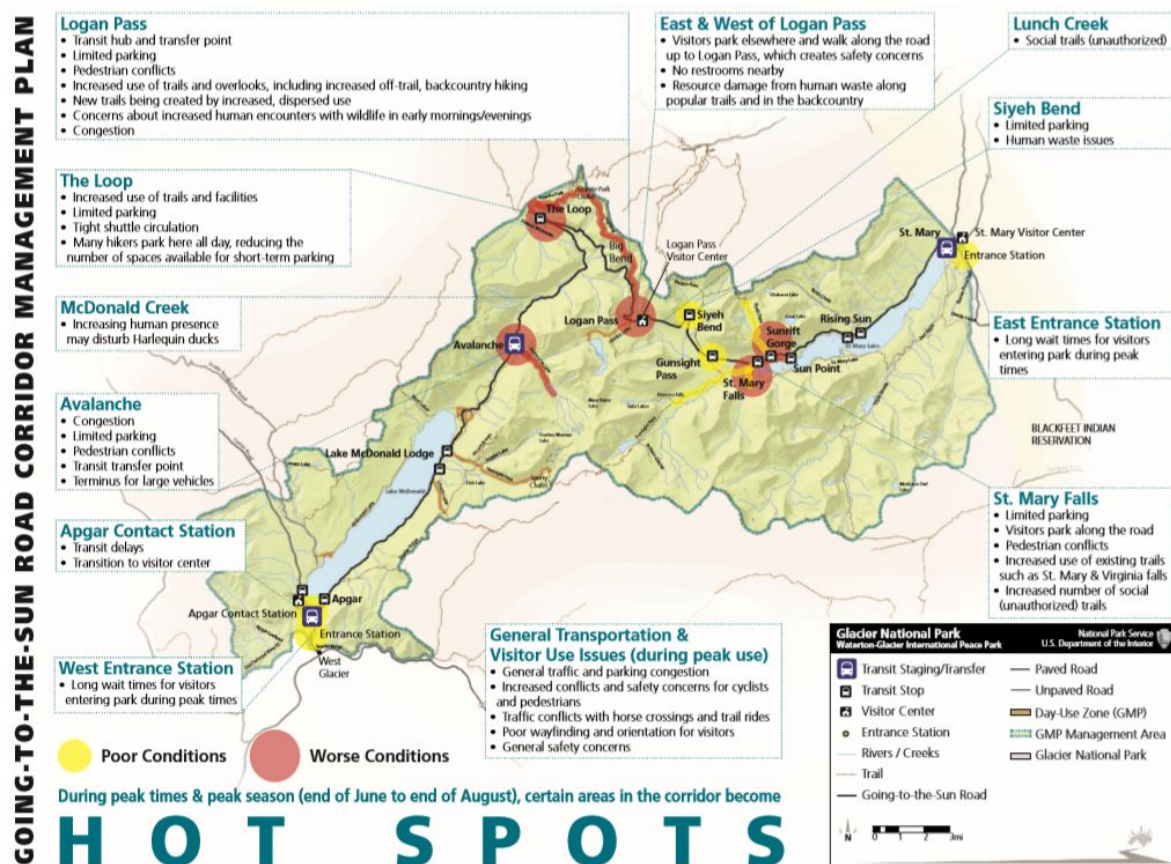

Figure 22: NPS Analysis of GTSR

Additionally, the document cites “ideal conditions” such as “Providing visitor access to high-quality, seasonally appropriate recreational opportunities such as hiking, horseback riding, ....., photography, and experiencing the only historic chalets in the national park system”, and to “operate and maintain transportation vehicles and assets such as buses, shuttle stops, parking areas, roads, trails, and signs to promote uniformity and efficiency.” (nps, 2019). Also, they focus on “Protecting natural processes, conditions, and values”, and “ensure that the use of the roadway does not interfere with the protection and enhancement of the diverse habitats of iconic wildlife” (nps , 2019). The park is striking a balance between striving for a positive visitor

experience and preserving the park itself. Our proposed solution to the congestion issue will benefit from the additional parking lot and shuttles.

## **2.7 Related Project Overview**

### **2.7.1 Previous IQP Projects**

#### **Congestion Management in Glacier National Park**

In 2018, a WPI research team analyzed and offered solutions to the congestion problem in Glacier National Park. This research team determined that the best way to provide information to visitors was through its website. It was determined that maps, the NPS website, and tour books were the three most popular resources that visitors used to plan their visit to the park. Approximately 55% of the visitors used the Glacier NPS website to help plan their trip (Barrameda, 2018).

The 2018 WPI research found that the most viewed page on the Glacier NPS website is the webcam page. The WPI team determined this was because many fans of the park like to check the webcams to see the scenery and visitors also like to check on the current weather conditions. The webcam page is also the most viewed because visitors often search for NPS web pages instead of searching through the NPS home page. Another popular way that visitors find NPS pages is by clicking on the links off the home page and plan your visit page.

#### **Implementation and Design of Webcam Systems for Traffic Monitoring in Acadia National Park**

The WPI Acadia National Park Webcam team and our team in Glacier National Park worked hand in hand on our projects with the same overall goal in two different locations. Our proposals mirrored each other, testing both the static-solar and the mobile webcams, as well as designing a website that would display parking conditions to the visitors and park employees (Hollander, Yang & Zhu, 2019). In the development stage, the Acadia team focused heavily on the static-solar webcam's hardware and software where our team focused on the mobile webcam.

Both webcams were tested at both National Parks to verify the proof-of-concept and to compare the positives and negatives of both webcams.

The Acadia National Park team completed their project in the summer of 2019, whereas our team started three months after in late August. We were able to receive feedback and review results. Given that both webcams were verified to work, we capitalized on their previous findings and focused more on congestion problems in Glacier and additions to the system instead of testing the hardware and software of the webcams.

### 2.7.2. Existing Webcams in Glacier National Park



**Figure 23: Lake McDonald Webcams**

Glacier National Park has already set up webcams in the park. Approximately twenty webcams were deployed in the park in October, 2019 and all but one of the webcams are used for weather. Most of the webcams are looking at nature, and are used to understand the weather conditions in the area. The only webcam looking at a parking lot is on the Logan Pass Visitor Center which gives a clear view of the parking spots. All the webcams are hard wired to the



utility lines and infrastructure of the park. This solves the problem of having no cellular connectivity in the park and still being able to upload the pictures taken onto the website.

## 2.8 Raspberry Pi Webcams

The Raspberry Pi is a small, affordable and easily programmable computer. The system can be fitted with GPS, cellular networking, and camera attachments. It can also be programmed to track its location using the GPS, to take pictures at certain times, and at predetermined locations. The system also has network connectivity so any data collected can be uploaded to a server and accessed later. The Raspberry Pi also has onboard storage so it can collect and store data without a network connection (Upton, Halfacree, 2014).

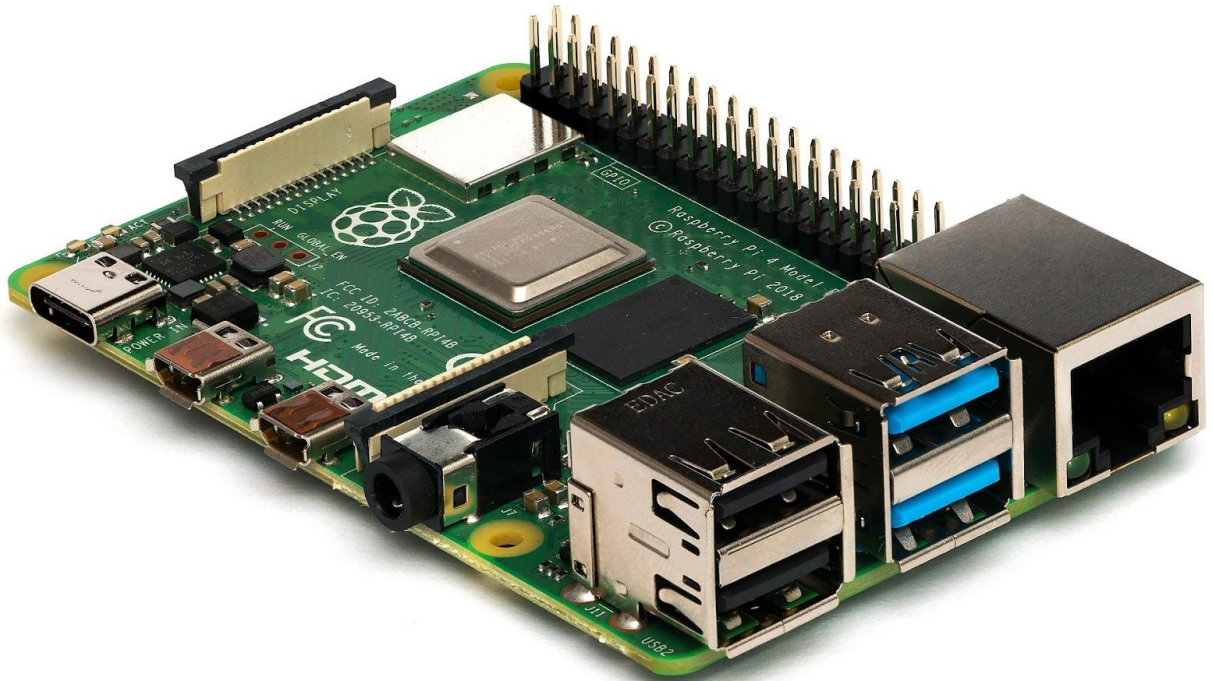

**Figure 24: Raspberry Pi**

Source: Wikipedia contributors. "Raspberry Pi." Wikipedia, The Free Encyclopedia.

Wikipedia, The Free Encyclopedia, 3 Oct. 2019. Web. 7 Oct. 2019.

## 2.9 Cellular Networks

Cellular networks are communication networks that operate wirelessly in the final stage. Cellular networks are broken up into individual cells. Cells can vary in size from around 10 meters up to 40 kilometers. Each cell has at least one, but more commonly, three cell towers, or their equivalent. Each cell uses different frequencies to the neighboring cells reducing the chance of interference and also overlap slightly so that the mobile device can be handed off between cells without interruption. When cells are joined together they create a cellular network that can span huge geographical areas. These networks allows any device with a mobile broadband modem in it to wirelessly communicate with any other device connected to the network. (Miao, Zander, Sung, Slimane)

There are a number of factors that can reduce or even completely block a mobile device's access to a cellular network. One of them is the geography of the landscape around the mobile device. (Miao, Zander, Sung & Slimane, 2016)

Another factor that has an impact on a mobile device's access to a network is the weather. Moisture in the air can affect a signal's ability to travel long distances as signals struggle to travel through dense clouds and heavy rain. Snow and ice have less of a negative effect on signal strength due to being less dense than liquid water, but heavy snow can still negatively affect the strength of a signal. (Miao, Zander, Sung & Slimane, 2016)

### **3. Methodology**

The project's goals were to create a heatmap of cellular connectivity, test a mobile webcam system and a static-solar webcam system, design a website to display the data, and offer recommendations to the park in an effort to assist in the mitigation of the traffic congestion. To accomplish this, we had five objectives.

Our team objectives were to:

- Create a cellular connectivity map of the Going to the Sun Road
- Implement and test static-solar webcam system.
- Implement and test a mobile webcam system.
- Research and develop a website that will display the data from the webcams.
- Evaluate the website and offer recommendations.

#### **3.1 Benchmarking**

To achieve our objectives we used benchmarking which showed us the strategies that similar parks with the same problems implemented. Mount Rainier National Park and Acadia National Park both have traffic congestion problems and are using webcams to provide visitors with information on weather and parking conditions. Visitors can find this information on the park's respective websites which we used as a baseline for designing our own. We viewed the data presented on these websites and found that some information was useful and easy to find while some data was non beneficial or difficult to interpret. With this research, we learned some methods of displaying data that made it clear and easy to interpret for the readers.

For instance, Yosemite National Park uses webcams to show current weather condition information in a bar at the top corner of the webcam feed. This feed displayed the date, time of day, and exactly what the webcam was showing allowing the viewer to know exactly what they were looking at. We implemented the idea of an information bar associated with every individual webcam picture to reduce confusion for the reader and provide them with the most relevant details for that location.



Alternatively, benchmarking allowed us to determine some data presentation techniques that can make the information one is looking for more difficult to find. On the Glacier National Park there is only an alphabetical list of the current webcams used in the park. As there are only approximately nineteen webcams in the park, this is an acceptable way of displaying the data. However, we were able to interpret that a single list would be a challenging way of finding a specific webcam view. For instance, if a visitor is unsure of the name of the area they would like to visit, an alphabetical list is of little value to them. To combat this problem, we took into consideration the use of a search bar and interactive map that would allow a user to easily identify their desired webcam view.

## Webcams



The weather can change fast on the mountain.  
Stay up to date with Mount Rainier's webcams.

NPS Webcam Photos

Is the mountain out? What's the weather like in the park? Are the parking lots at Paradise and Sunrise full? Check out Mount Rainier's live webcams to find out:

- Longmire Area**
- [Longmire](#)
- Paradise Area**
- [Mountain](#)
- [East](#)
- [West](#)
- [Visitor Center](#)
- [Tatoosh](#)
- [Air Quality](#)
- High Camps - Down for the Winter*
- [Camp Muir](#)
- [Camp Schurman](#)
- Sunrise Area - Down for the Winter*
- [Sunrise Mountain](#)
- [Sunrise East](#)

For snow depth at Paradise and other current conditions, check the [weather](#) page.

**Figure 25: Mount Rainier National Park Webcam Website**

Source: nps, 2019

## 3.2 Heatmap

To make a heatmap we first determined which cellular provider was the strongest in the park. To determine this we spoke to local experts and examined cell tower maps. We then created the heatmap by modifying the mobile webcam to log GPS coordinates and a cellular strength indicator to a CSV, or comma separated value file.

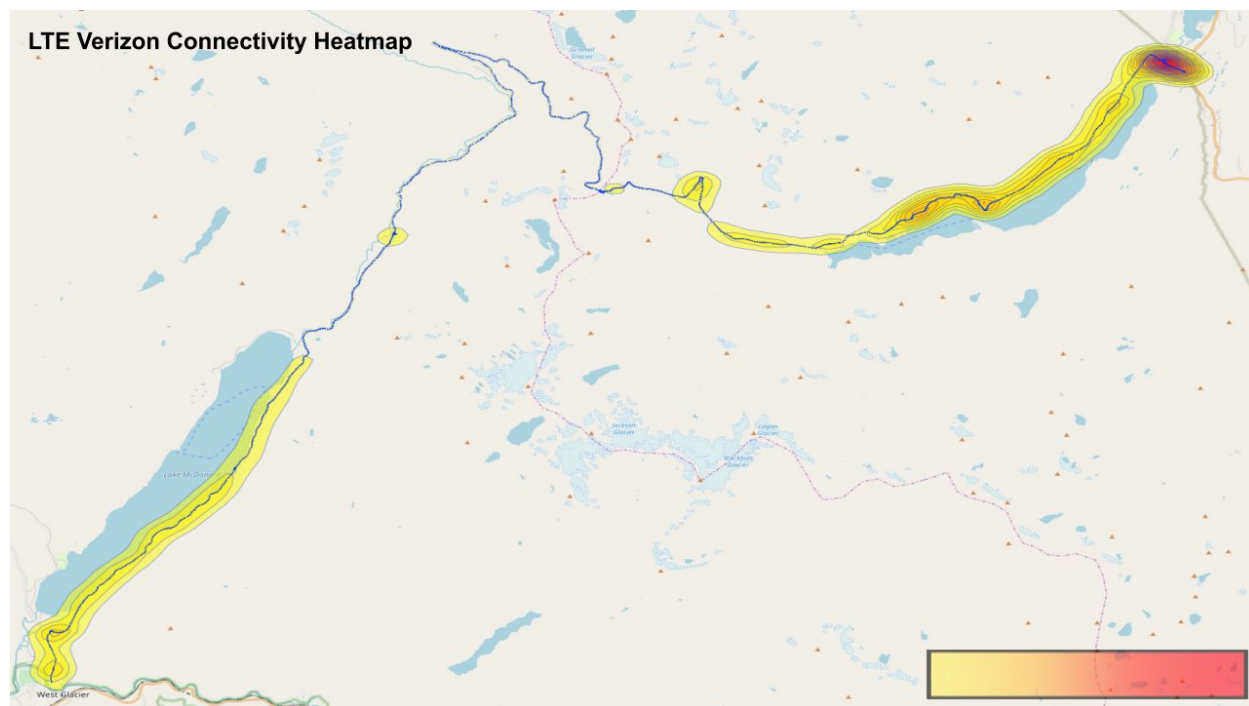
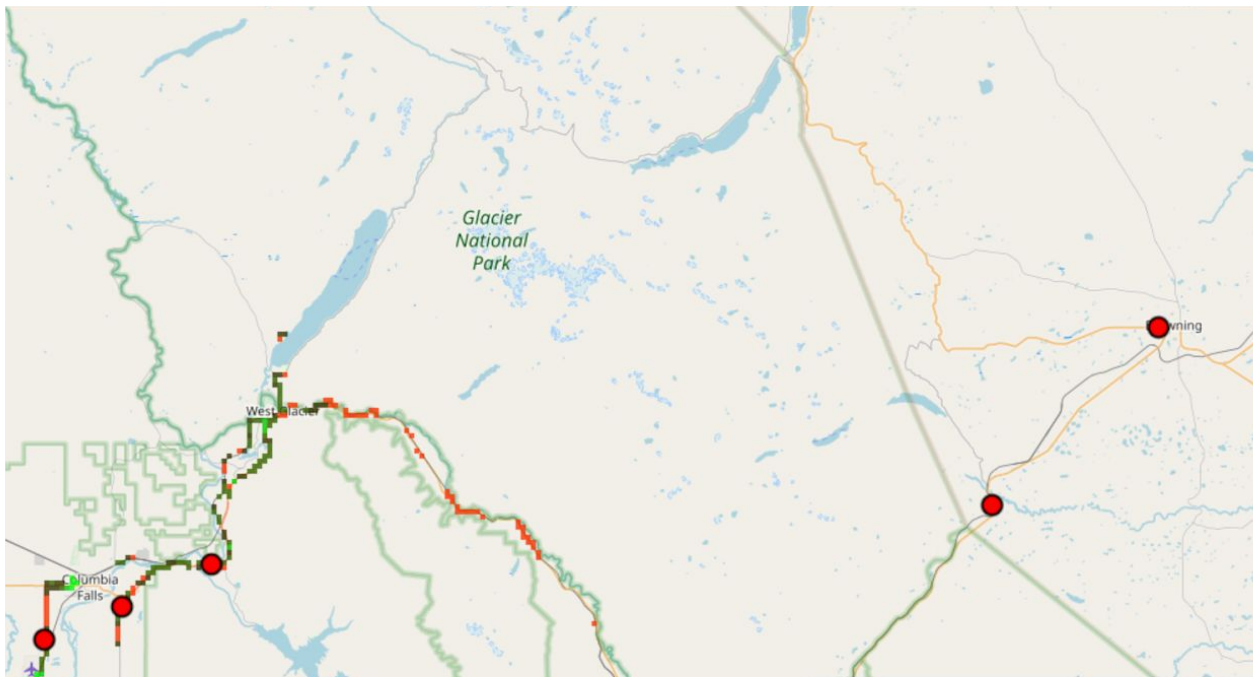

**Figure 26: Cellular Connectivity Heatmap**

The webcam took these readings every five seconds and logged them to the file, ensuring an even spread of data points along the Going-to-the-Sun Road. This format allowed us to import the data into programs like Microsoft Excel and carry out calculations such as converting the strength indicator to an actual decibel reading. With the decibel reading and coordinates, we used a website to create a heatmap of the Going-to-the-Sun Road according to the signal strength at each area.



**Figure 27: T-mobile Cell Tower Map**



**Figure 28: AT&T Cell Tower Map**



**Figure 29: Verizon Cell Tower Map**

### **3.3 Verify the Concept of a Static-Solar Webcam System**

We worked closely with the students from the 2019 Bar Harbor research team before and during our project. While they designed and developed the static-solar webcam, we designed and developed the mobile webcam system. Therefore, our objective was to deploy the static-solar webcam and verify the concept.





**Figure 30: Static-Solar Webcam in the Field**



**Figure 31: Solar Panel**





**Figure 32: Battery**



**Figure 33: Static-Solar Webcam**

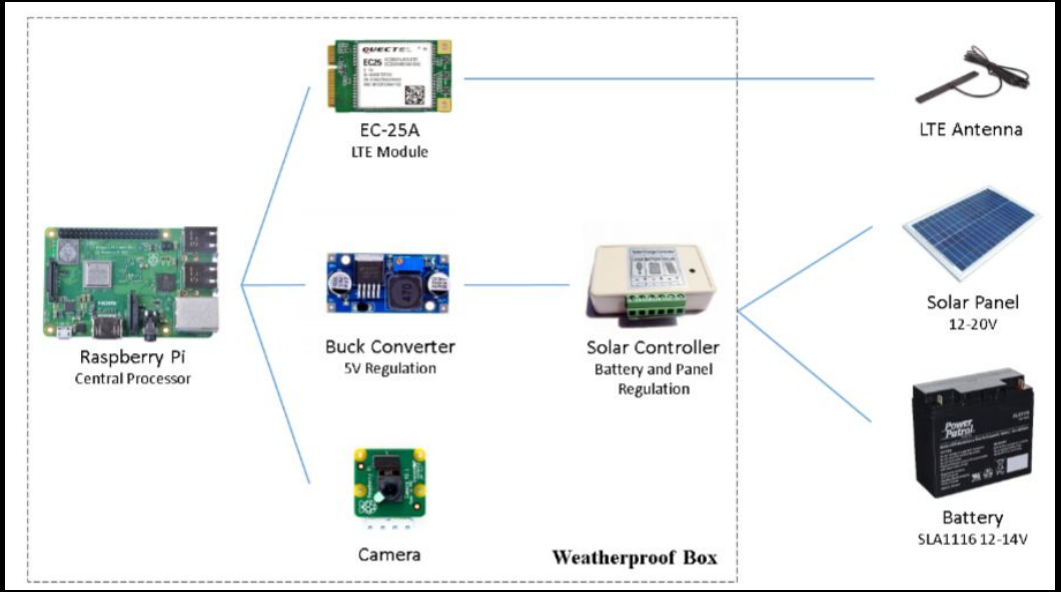

Figure 34: Diagram of Static Webcam Components

Source: Hollander, Yang, Zhu

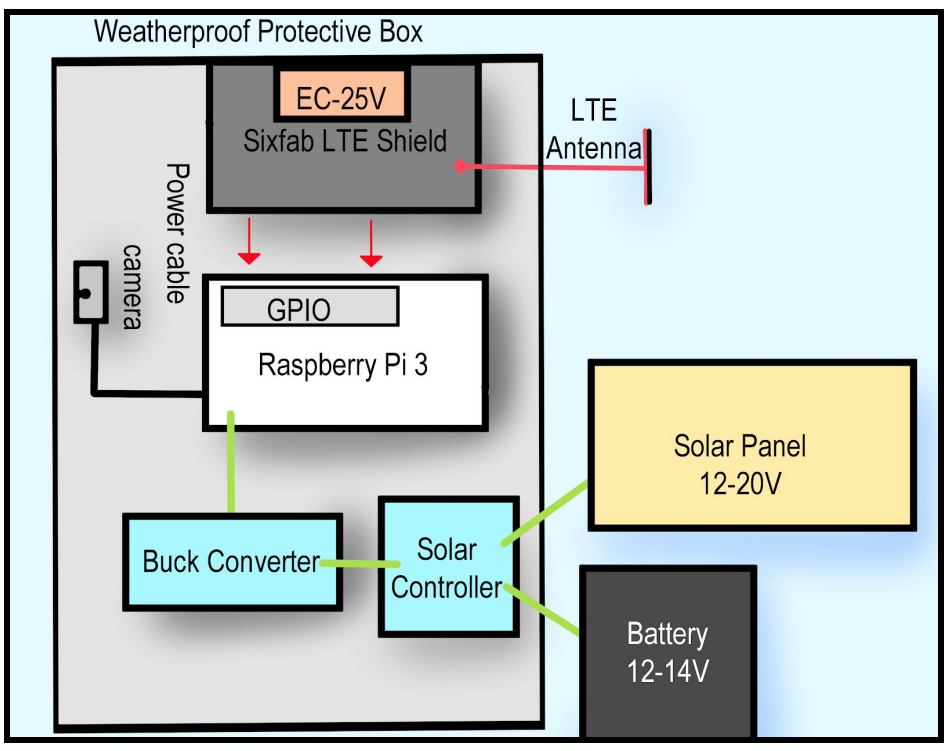

Figure 35: Static-Solar Setup Diagram

The static-solar webcam is built with the Raspberry Pi 3, equipped with its camera module and a 4G LTE module. It is powered by a lead acid battery, which is charged by a solar panel and uses cellular signal to FTP the images up to a server.

We deployed the static-solar webcam over four days at Saint Mary's Falls Parking Lot. However, despite the short deployment time, we were able to capture 1680 pictures of the parking lot.

### **3.4 Implement and Test a Mobile Webcam System**

Our mobile webcam design had to meet these criteria:

- Take high resolution images
- Upload high resolution images to a server
- Fit on the inside of a car without causing distraction
- GPS compatible
- Onboard storage for multiple high resolution images
- Operate and take pictures autonomously
- Function from power supplied by a vehicle

To implement and test the mobile webcam system we decided to use a Raspberry Pi 3. The operating system on the Raspberry Pi 3 is Raspbian, and the majority of the code was written in Python 3. We then installed the Sixfab mPCI-E Base LTE Shield, Quectel EC-25-V, and Raspberry Pi Camera modules onto the Raspberry Pi. These parts allow the mobile webcam to connect a cellular network and upload the images it takes to a server. To enable the LTE chips connectivity and GPS capabilities we attached a GPS antenna and a LTE antenna to the Pi. We programmed the Raspberry Pi to be able to take and save images at predetermined locations using the GPS capabilities of the LTE module. We also programmed the Pi to upload the images when in range of a cellular tower.





**Figure 36: The Sixfab LTE Shield**

Source: Sixfab. (2019, October 7). 3G/4G & LTE Base Shield for Raspberry Pi.



**Figure 37: LTE Antenna**

Source: YOTENKO. (2017, August 16). 3dbi 3G 4G Antenna LTE 700-2600MHz Omni Directional GSM WiFi Antenna SMA Male 3M.



**Figure 38: GPS Antenna**

Source: QGP Supply. (2014, July 19). Waterproof GPS Active Antenna 28dB Gain, 3-5VDC, SMA.



**Figure 39: Pi Camera**

Source: Raspberry Pi. (2016, April). Camera Module V2 – Raspberry Pi.



**Figure 40: Quectel EC25-V**

Source: Evelta Electronics. (2019). Quectel EC25-V LTE Mini PCIe Module.

To prep the webcam for testing we drove the length of the Going to the Sun Road and logged GPS coordinates, creating a database of pull offs and parking lots. We then fed the database to the program we created and by doing this the program was able to take pictures at locations we specified.

The Raspberry Pi was mounted on the dashboard of a car, powered by a Cigarette Lighter USB Adapter. As we drove the Going to the Sun Road, the code constantly checked the current location of the device using the GPS module. Once it detected that the device was within the range of one of the pre-programmed locations, the webcam then took and saved a picture. Simultaneously, a separate script running on the Pi monitored the current level of cellular connectivity. When the level of connectivity was sufficient, the saved pictures were uploaded to a server where the pictures were easily available to be accessed by a website.

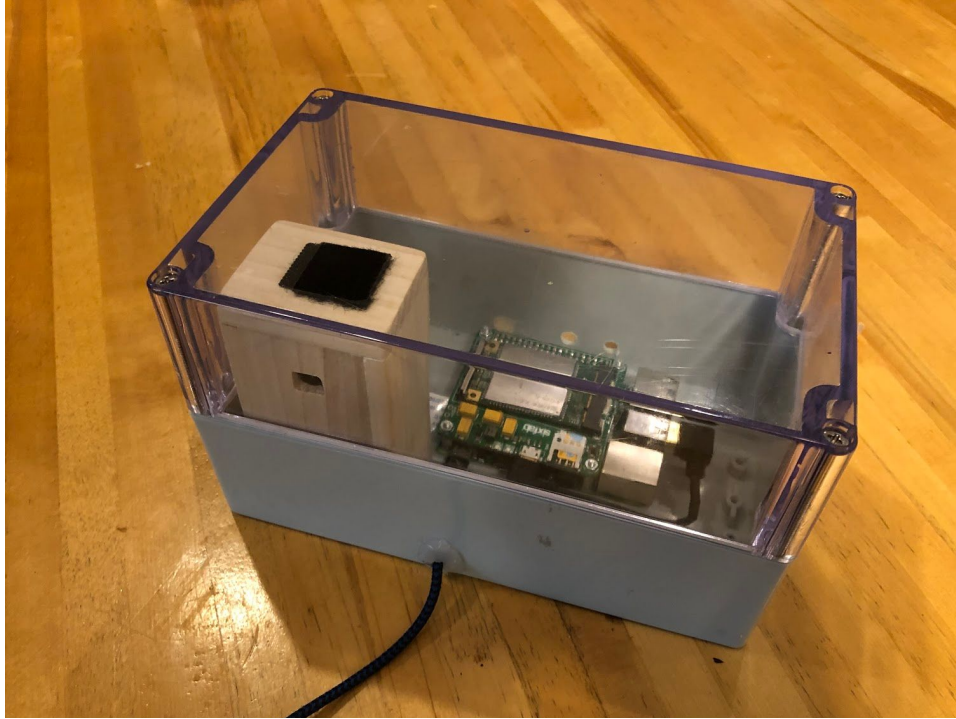

Figure 41: The Mobile Webcam

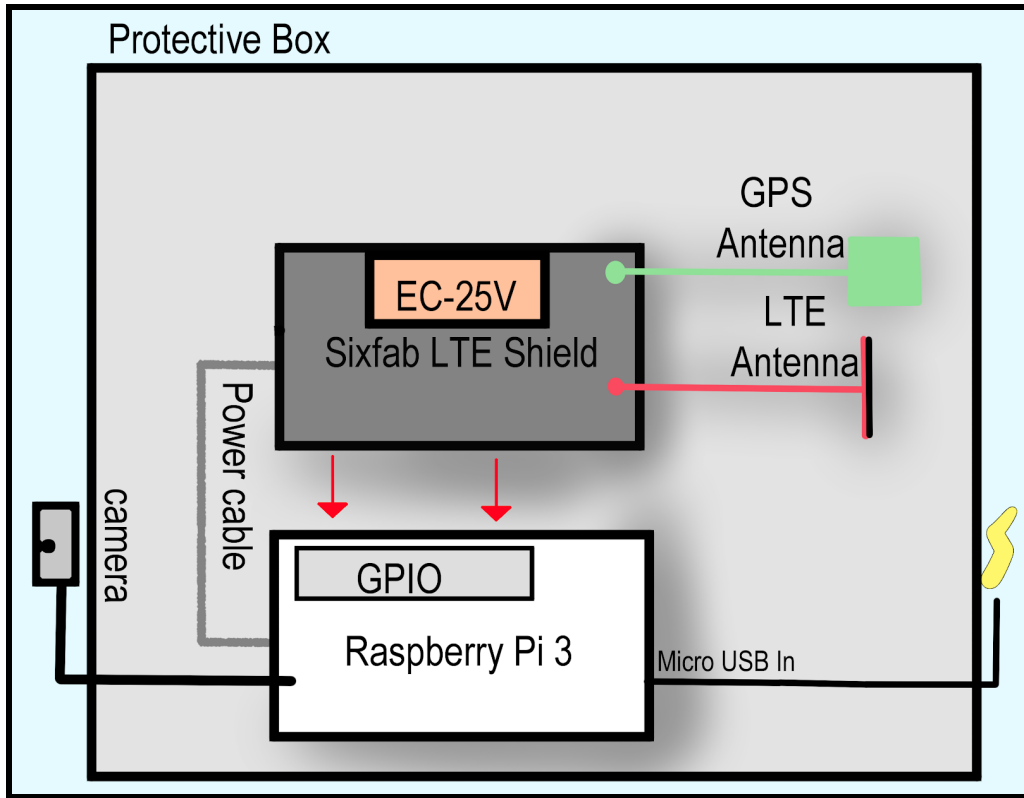

Figure 42: A Diagram of the Mobile Webcam





**Figure 43: Mobile Webcam in Van**

### **3.5. Design a Website to Display Data**

The website was created with the intention of providing parking information and traffic conditions to visitors and the park employees in real time. It was aimed to be clear and easy to use while accurately depicting where in the park the pictures were taken. The static and mobile webcams both hooked up to the website and the pictures were sorted into their respective locations.

## Hiking Lake McDonald



**Figure 44: Glacier Hiking Trails Website**

To easily incorporate our demonstration website to the official Glacier National Park website, we added an interactive map of the Going to the Sun Road to point out the parking options (see figure 44). The cooperation with the official Glacier National Park website was necessary because up to 55 percent of visitors use the website to plan their trips (Barrameda, Rizzo & Vose, 2018). Along with a view of the road, individual sections are available for selection. These pages will be useful for visitors who are interested in specific regions of the park.

What separates our proposed system from the current webcams at Glacier National Park is our archive system. The ability to see parking lot conditions from an hour, day, or years prior gives visitors valuable information for planning their visit. This also gives park employees the ability to find patterns in parking from previous years to make their strategies in advance.

The criteria needed for the website to give visitors the best options for planning include:

- Ease of navigation
- Compatible with the Glacier National Park website
- Effectively display where images were captured
- Clearly display images
- Archive of past images

### 3.5 Quantitative Data Analysis

Once images were collected, the next step was to analyze them. We rated the images based on five factors and applied numerical values to each of these factors. These data points helped us determine the feasibility of both the mobile and static webcam systems in Glacier National Park. The graph below shows the five parameters and their corresponding ratings.

Image quality	Information validation	Connectivity	Incident	Congestion
<ul style="list-style-type: none"> <li>• Very clear</li> <li>• Mainly clear</li> <li>• A little blurred</li> <li>• Very blurred</li> </ul>	<ul style="list-style-type: none"> <li>• Clearly reflect the information</li> <li>• Reflect the information with some distraction</li> <li>• Cannot reflect the information</li> </ul>	<ul style="list-style-type: none"> <li>• Achieve intended upload period</li> <li>• Have some delay with intended upload period</li> <li>• Cannot upload the image</li> </ul>	<ul style="list-style-type: none"> <li>• Have incident</li> <li>• Do not have incident</li> </ul>	<ul style="list-style-type: none"> <li>• Very congested traffic</li> <li>• Congested traffic</li> <li>• Slow-moving</li> <li>• Clear road</li> </ul>

**Figure 45: Quantitative Analysis Classification**

After rating all the images, we analyzed the data with two approaches: descriptive statistics and inferential statistics. Descriptive statistics is the first level of analysis, which provides absolute numbers so that we know how good images were relative to each other. These statistics helped us figure out some basic patterns in the webcam systems. Inferential statistics were used to generalize results and make predictions as to what future data would hold. This helped us develop the recommendations for Glacier National Park. The graph below shows the different levels of analysis.



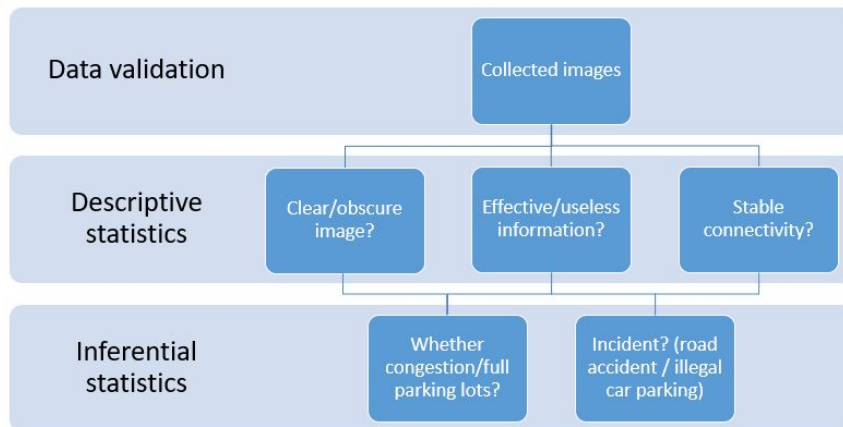

**Figure 46: Data Validation**

External factors like weather or light will decrease the efficiency of the webcam systems. We recorded the external factors for each image to determine the influence they had on the quality of the image. The graph below shows the four factors we have preselected as external factors that will impact the data.

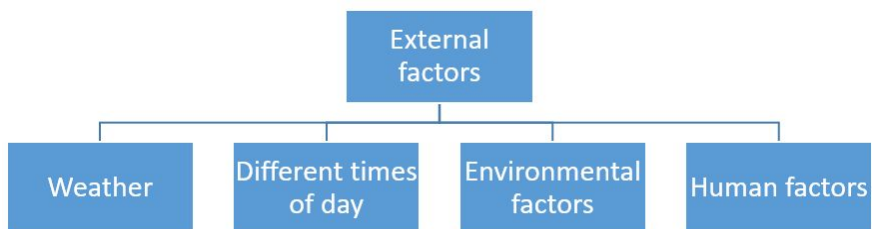

**Figure 47: External Factors**

The final analysis contributed to determining which system is more viable for use in the park, through a clear numerical ranking system.

## 4. Results and Discussion

### 4.1 Heatmap/Connectivity Results

The heatmap of Verizon cellular connectivity shows that there is some service along the Going-to-the-Sun Road allowing for the webcams to upload their images through a cellular network. The service is along the edges of the park and tapers off as you get closer to Logan Pass. We created a map (see figure 48) using the data we collected as well as a key to better help the viewers to understand what the cellular connectivity is like in Glacier National Park.

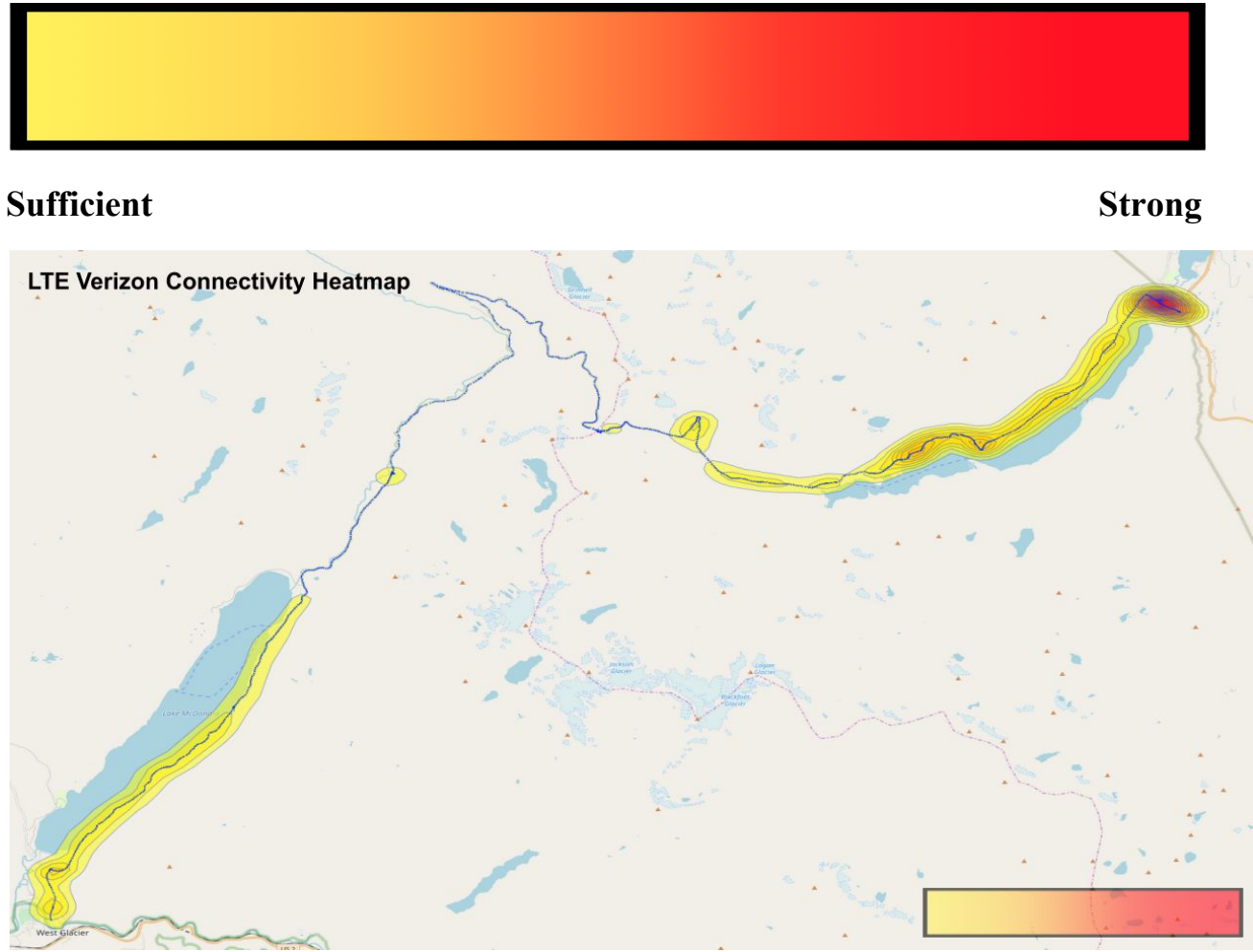
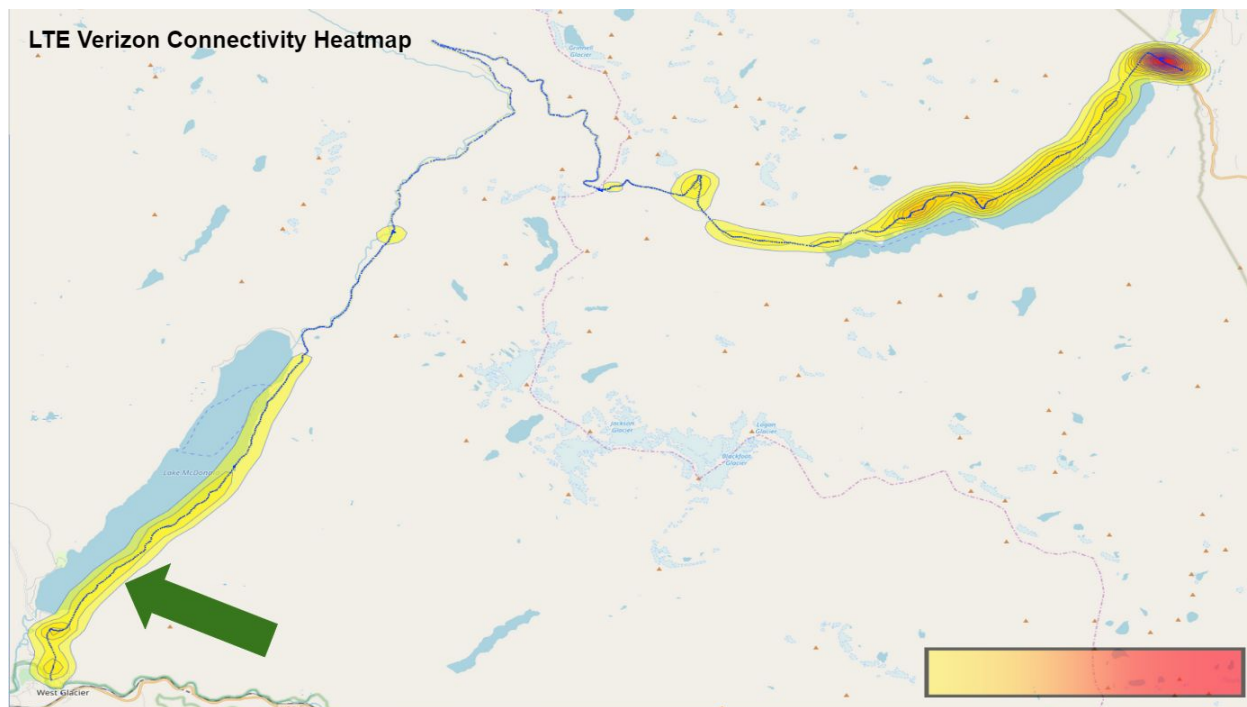

Figure 48: Verizon Heatmap and Key

The key used for the map can be found at the top of Figure 41. Light yellow means there is service in the area and it is sufficient. However, it is spotty and the cellular connection can be dropped at anytime. With varying weather effects, such as rain and overcast, the service in those light yellow areas may not be reachable, resulting in no cellular connectivity. The map is of Glacier National Park and the blue line is the Going-to-the-Sun Road. Figure 49 depicts how there is slightly darker yellow on the west side of the park, along the first half of Lake McDonald.



**Figure 49: Heatmap Arrow at First Half Lake McDonald**

In that area, there is modest service that isn't likely to be dropped. Pictures from the webcams could easily be sent to a server through FTP in that area. The other half of Lake McDonald has a drop in connectivity (see figure 50). In this area, there could be latency issues due to weak or dropped signal, especially during cloudy or rainy days.

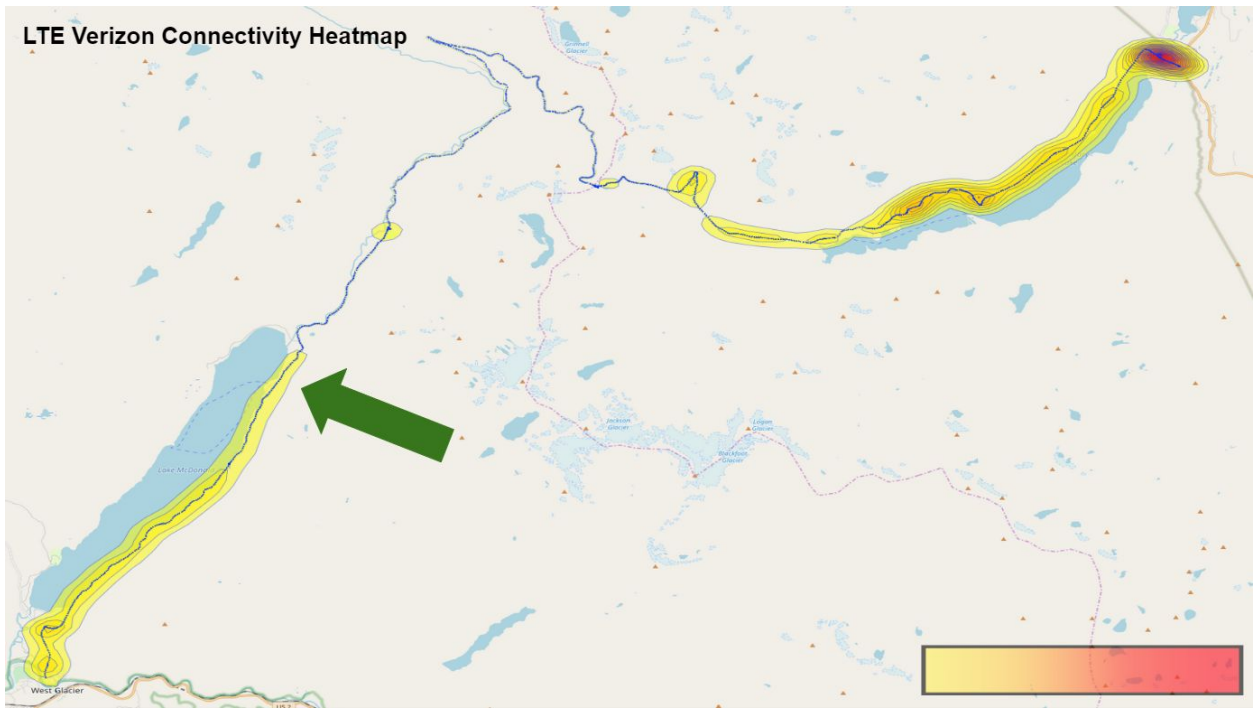

**Figure 50: Heatmap Arrow at Second Half Lake McDonald**

Past Lake Macdonald, cellular connectivity is lost. There is some degree of connectivity at Avalanche, however it is transient and too weak to upload an image to a server. The signal then drops off again all the way to Logan Pass (see Figure 51).

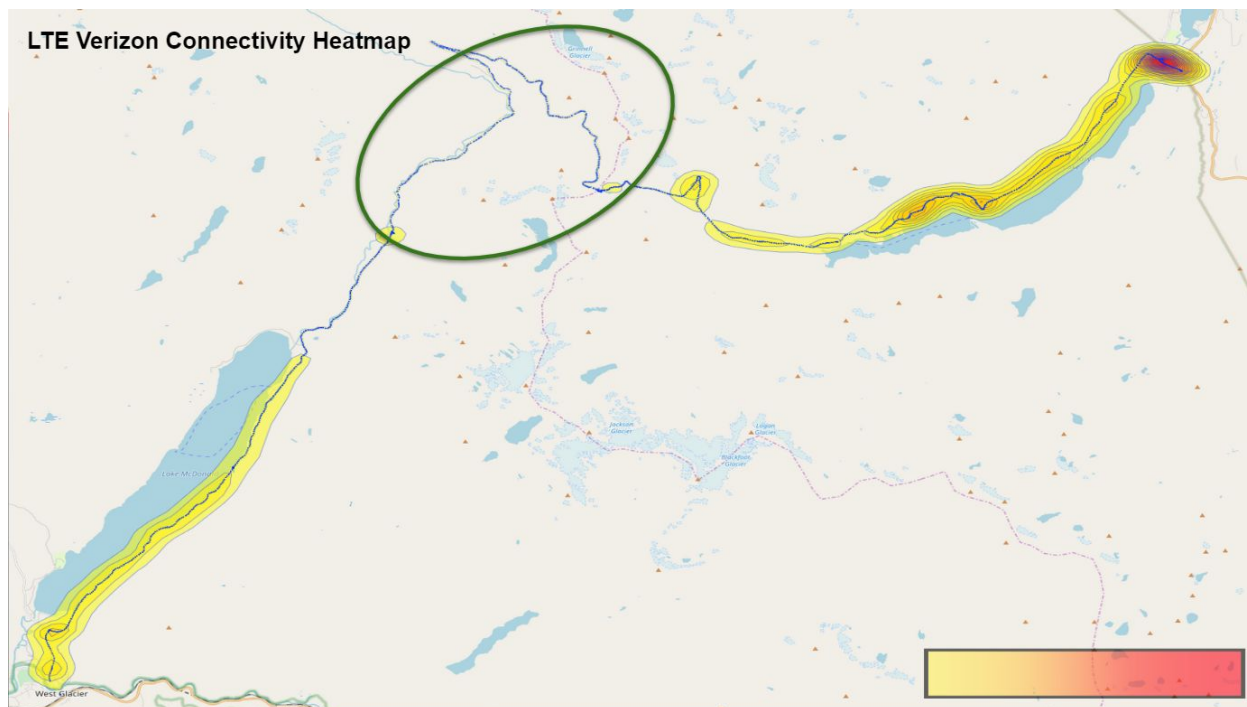

**Figure 51: Heatmap No Connection to Logan Pass**

Right after Logan Pass there is another transient pocket of cellular connectivity and again is not strong enough to be used for image uploading (see Figure 51). After the small connectivity pocket there is a much bigger pocket along a sharp bend that has a modest cell signal. After this area of service there is a small area with no service.

Going from west to east the service right before Saint Mary Lake starts off at sufficient, but it turns into being modest (see Figure 52). It then drops back down to being sufficient and spotty. As you move along Saint Mary Lake the service improves. There is a big pocket of strong connectivity along the first area of Saint Mary Lake. The area along Saint Mary Lake is relatively flat so the cell signal has fewer obstacles, such as mountains, to go through, improving and extending the signal compared to the west side of the park.

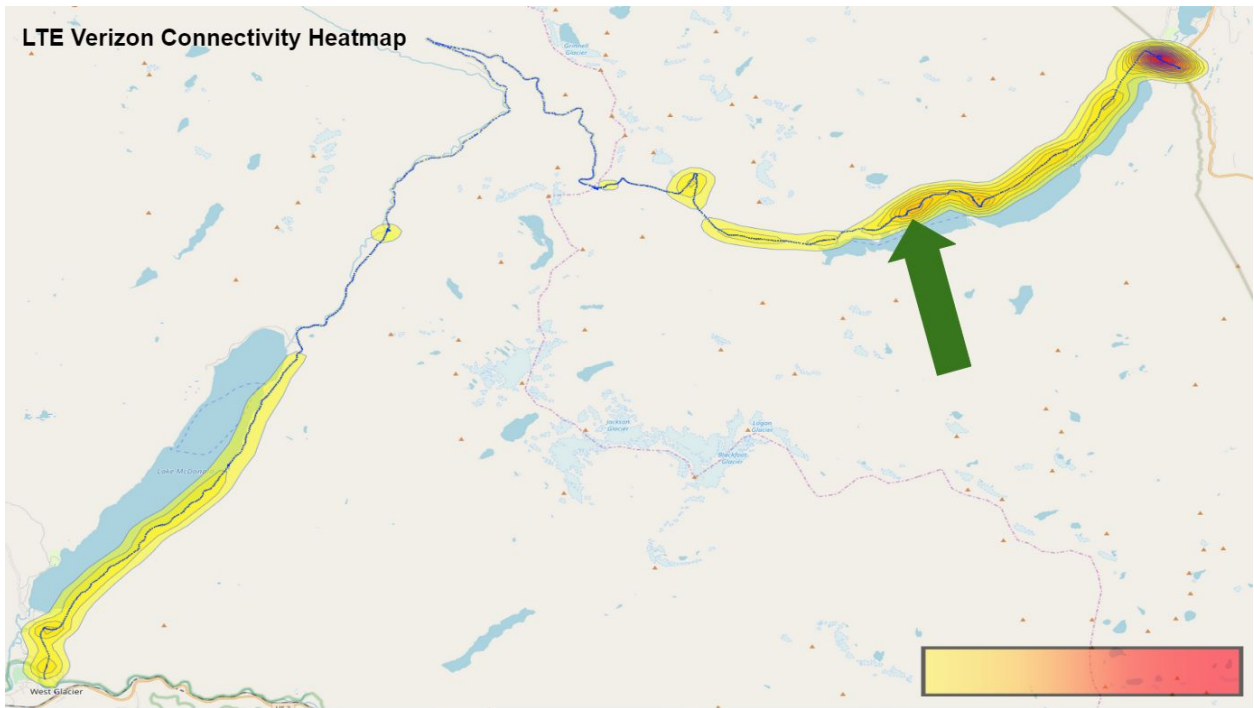

**Figure 52: Heatmap Saint Mary Lake Good Connection**

There is a Verizon cell tower at the edge of the park near Saint Mary Lake which contributes to the stronger signal strength. That is why the end of the Going-to-the-Sun Road is a very deep red color shown in Figure 53. The signal is a lot better on the east side of Glacier National Park than it is on the west side of the park.



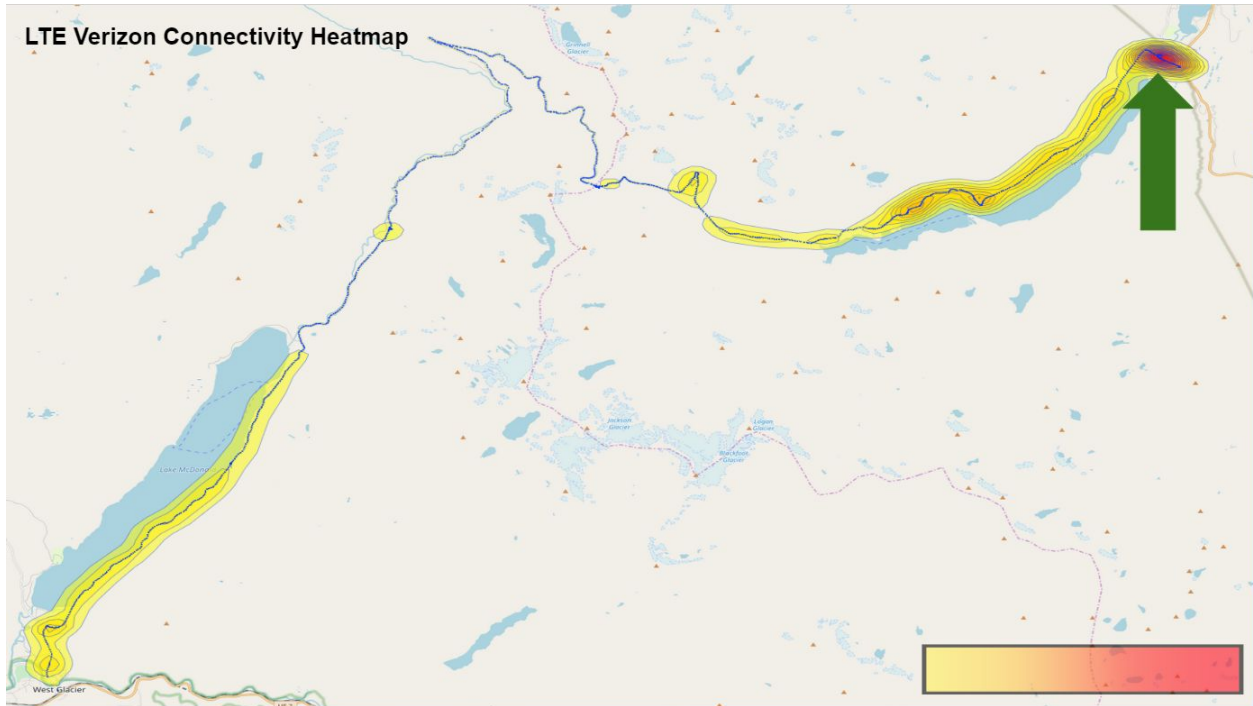
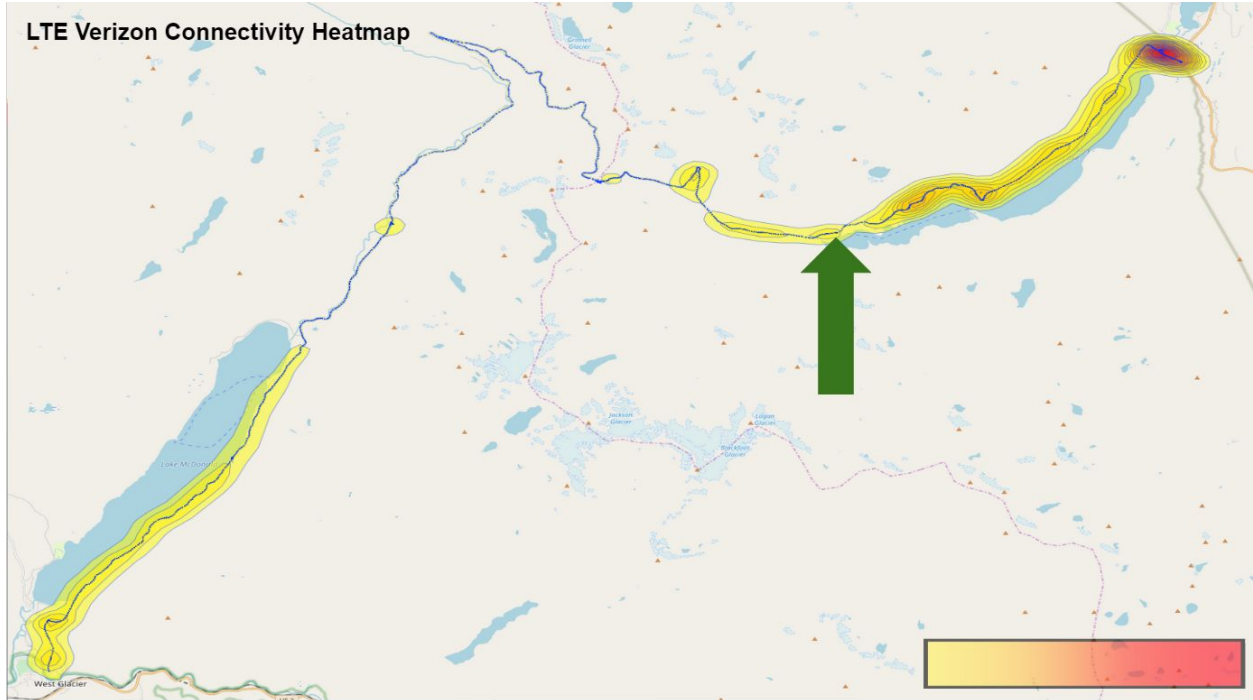

**Figure 53: Heatmap Cell Tower Great Connection**

## 4.2 Static-Solar Webcam Results

The static-solar webcam successfully took pictures (see Figures 56-59) and uploaded them via cellular service while at Saint Mary's Falls Parking Lot for four days. The webcam was able to survive rain and still produce acceptable pictures due to the applied waterproofing sprayed onto the webcam. The solar panel and the battery were also able to survive the elements. Pictures were taken every 2 minutes and were uploaded to a server where they could be viewed online.

The biggest problem with the static-solar webcam was the lack of cellular connectivity in the park. The first provider we used was AT&T, but due to their lack of coverage there were very few parking lots with available connectivity. However, when we switched to Verizon, more parking lots became available due to increased cellular signal strength. This led to the webcam being placed at Saint Mary's Falls Parking Lot.



**Figure 54: Saint Mary's Falls Parking Lot**

The webcam was placed on the ridge on the other side of the road of the parking lot where it could easily be accessed for assembly and disassembly while also being difficult to see. The battery and solar panel were placed in the shrubbery so they were completely out of sight while the webcam was strapped to a tree as shown in Figure 55. The webcam was hard to view from the parking lot and most likely went unnoticed by visitors.



**Figure 55: Closeup of Static-Solar Webcam**



**Figure 56: Static-Solar Webcam Clear Weather**





**Figure 57: Static-Solar Webcam Rainy Weather**



**Figure 58: Static-Solar Webcam Empty Parking Lot**



**Figure 59: Static-Solar Webcam Overcast Weather**

### **4.3 Mobile Webcam Result**

Once calibrated, the prototype mobile webcam successfully took pictures at preset GPS points along the Going to the Sun Road. In over 4 trips, 127 pictures were captured and uploaded to a server when cellular service was available. The webcam power was provided by the vehicle, thus eliminating the need for solar power.. The GPS antenna and the LTE antenna were placed on the roof of the vehicle to get the best connectivity. The majority of pictures taken at pull-offs were very usable. Pictures of parking lots were not as useful as many lots in the park are spread out and visibly hidden from the road.





**Figure 60: Mobile Webcam in van**



**Figure 61: Picture taken by mobile webcam from right side of road**





**Figure 62: Picture taken by mobile webcam from left side of road**

#### 4.4 Quantitative Data Analysis

We conducted the quantitative data analysis on both the static-solar webcam and the mobile webcam.

Score	Description	Example
1	The picture was taken at 6:55 pm. The parking lot is unable to be seen in the image due to lack of sunlight.	









2	<p>Rain droplets covered the protective case, obscuring the image, however, the parking spots are still visible.</p>	
3	<p>A small amount of rain droplets covered the protective case. The parking spot is fully visible.</p>	
4	<p>The image has a heavy glare from the sun, not impacting the parking spots very much.</p>	
5	<p>Little overcast, clear display of parking spots.</p>	

Figure 63: Quantitative Data Analysis Static-Solar

Score	Description	Example
1	<p>The image distance from the lot makes it difficult to make out.</p> <p>The glare from the sun blinds the spot, further obscuring what can be seen.</p>	
2	<p>There is a car in the way of the opposite side pull off, blocking any information that could be gathered. The glare from the sun also impacts the quality of the picture.</p>	
3	<p>The picture was taken in line with the cars in the pull off, making it difficult to see any open spots.</p> <p>The picture was also taken too far back.</p>	
4	<p>The pull off is clearly seen but the picture is dark, slightly impairing picture quality.</p>	

5	The pull off is seen perfectly from the right distance and angle.	
---	---	--

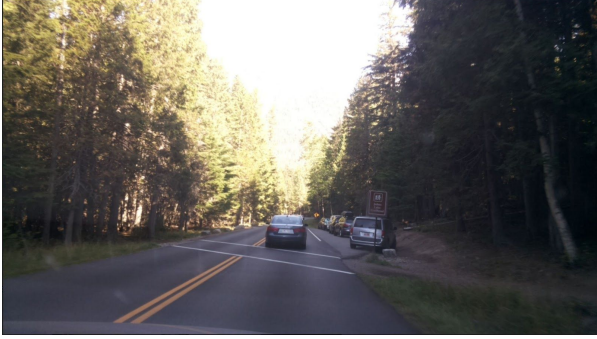
**Figure 64: Quantitative Data Analysis Mobile**



## 4.5 Website

By collecting all of the webcam pictures on an easy to access website, the visitors of Glacier National Park can help relieve the congestion by educating themselves on the current state of the park congestion. Ideally, if visitors enter the park knowing about the congestion trends, they can both avoid congestion as well as avoid creating it themselves.

The front page of the website consists of an interactive map of the Going to the Sun Road with hyperlink icons linked to corresponding parking lots and pull-offs (see Figure 65).

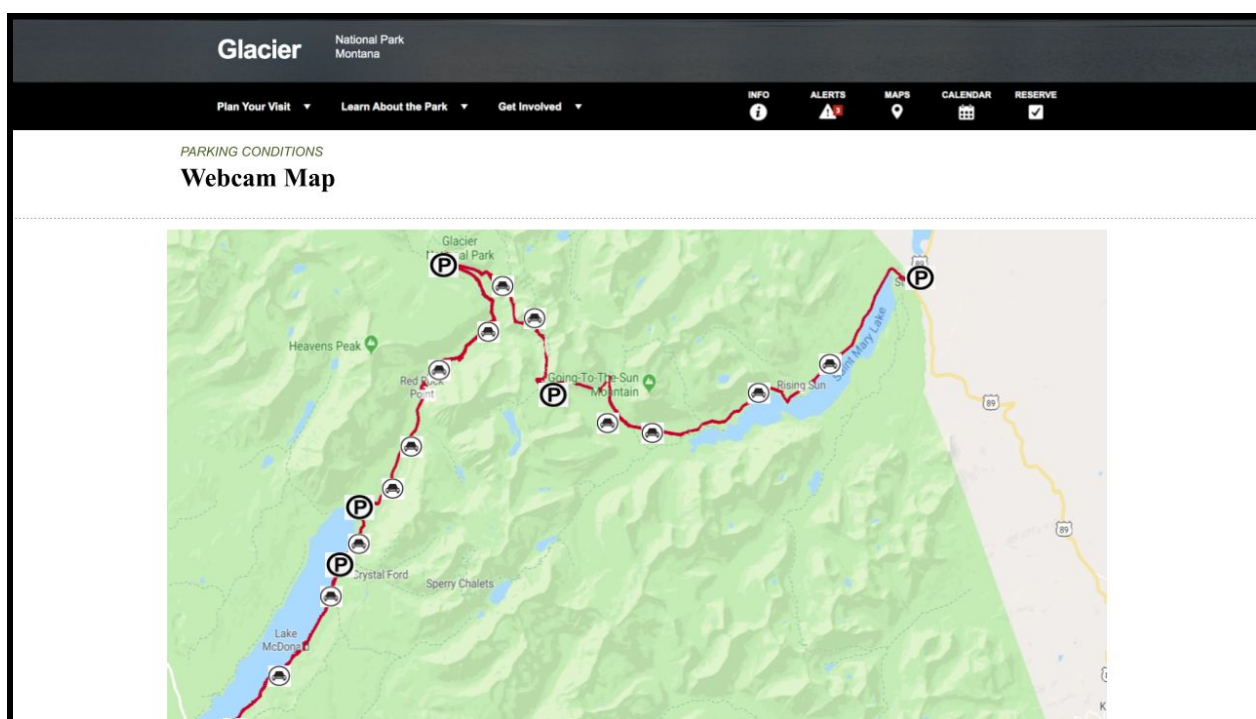

**Figure 65: Front Page of Website**

To see the real time parking conditions at specific parking lots or pull-offs, one can hover the mouse over an icon to see the name of the parking lot or pull-off. Clicking the icon will bring you to the current parking conditions for the location chosen. If the user clicked on a car icon labeled Lake McDonald Pull-Off 3, for example, they would be linked to the following page (see Figure 66):



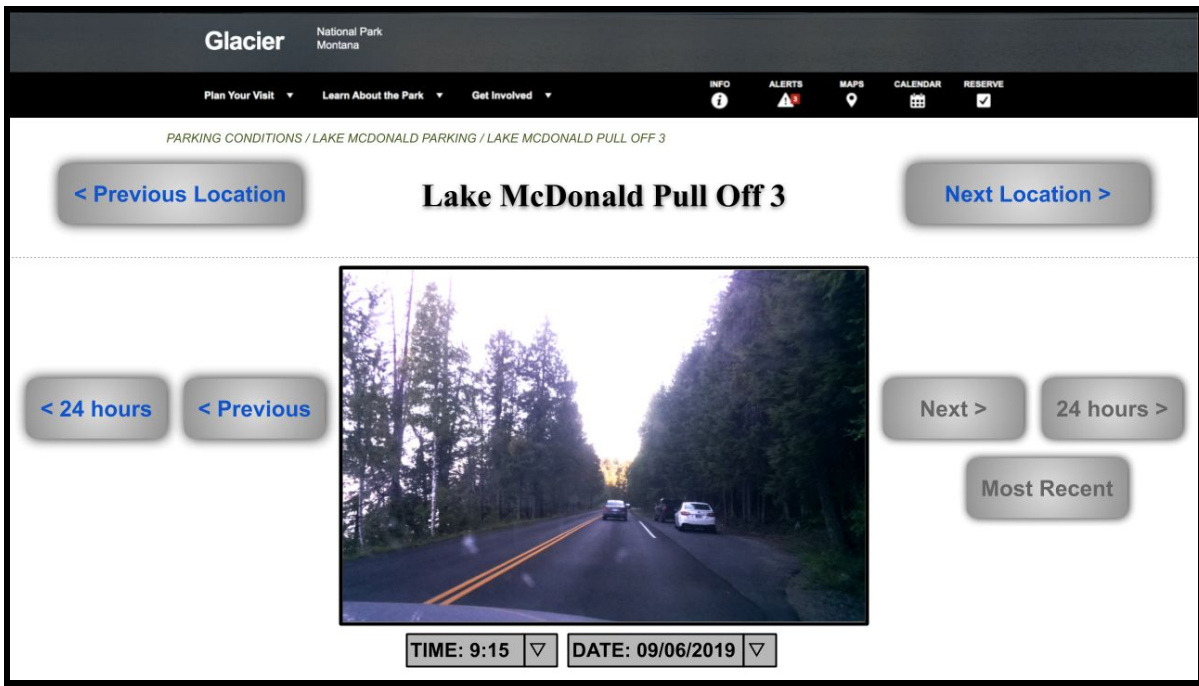

**Figure 66: Website Most Recent Picture**

Although the picture on the website is clear and easy to observe, a full screen image option is available by simply clicking on the picture (see Figure 67). To exit the full screen mode, the user can either click on the picture again or press the escape key.



**Figure 67: Full Screen Image**

There is also an in depth image archive system. The system allows visitors and park employees to view the previous picture, the next picture, as well as the ability to navigate back or forward 24 hours (see Figure 66). They also have the option to go directly to the current conditions from whatever date and time they are currently viewing. If users would like to see a specific time from the previous day, or had a particular week they wanted to view from a previous year, the drop down time and date menus provide an easy way to move through the image archive (see Figure 67).

The screenshot displays a web interface for an image archive. At the top, there are navigation buttons: "< 24 hours", "< Previous", "Next >", and "24 hours >". A central video frame shows a road scene with two cars. Below the video, there are two dropdown menus: "TIME: 9:15" and "DATE: 09/06/2019". To the right of the time dropdown is a calendar for July 2019. At the bottom of the interface, there is a footer with the text "EXPERIENCE YOUR AMERICA™" and links for "ACCESSIBILITY | PRIVACY POLICY | FOIA | NOTICES | DISCLAIMER" and "FAQ | NO FEAR ACT | CONTACT US | USA.GOV". The National Park Service logo and "National Park Service U.S. Department of the Interior" are also present.

JULY 2019						
MON	TUE	WED	THU	FRI	SAT	SUN
1	2	3	4	5	6	7
8	9	10	11	12	13	14
15	16	17	18	19	20	21
22	23	24	25	26	27	28
29	30	31				

**Figure 68: Time and Date Dropdowns**

## **5. Recommendations**

### **5.1 Heatmap Recommendation**

Although cell towers are not permitted within the National Park boundaries, they are being placed outside of the park boundaries (Reilly, 2018). As cell signals continue to get stronger across the US as well as the park, it is recommended that the park update a cellular heat map every few years. The cellular heat map should be made with varying carriers to get the full extent of the coverage in the park. This will also give an indicator as to which carriers are performing the best. To create the most accurate heatmap, the cellular data should be collected over multiple days with varying weather conditions. This will help to mitigate outlying data points caused by weather.

### **5.2 Static-Solar Webcam Recommendations**

To continue the process of implementing a static-solar webcam system in Glacier National Park we recommend that a limited number of webcams be manufactured and tested internally. New webcams should have a temperature probes attached so they will become capable of collecting temperature data. There is also the potential for a full weather station to be attached to the webcam, which could provide humidity, pressure and wind data.

We recommend that the park source webcam development out to a third party. While the prototype worked well, a specialized company could reduce the webcam's footprint and increase efficiency. Once manufactured, refer to a cellular heatmap and deploy the webcams to areas of interest with sufficient cellular service.

### **5.3 Mobile Webcam Recommendations**

To continue the process of implementing a mobile webcam system in Glacier National Park we recommend that a limited number of webcams be manufactured and tested internally on park shuttles. New webcams should have a temperature probe attached so they will become

capable of collecting temperature data. The mobile webcams can also be tested on other park vehicles.

On the shuttle, the mobile webcam should be mounted facing forward viewing road conditions in front of the vehicle. The webcam worked well when securely mounted on the dashboard of the vehicle looking through the front windshield. Having the webcam inside the vehicle also protects it from weather. We recommend that multiple pictures are taken at larger parking areas and particularly curved parking areas to ensure all parts of the parking area can be seen. Reducing the size of the mobile webcam is also recommended to increase mounting options. Finally, we recommend that the webcams be manufactured by an external developer to refine the design and allow for more webcams to be produced.

#### **5.4 Website Recommendations**

The proposed website serves as a prototype from which to develop a working website in the future. Some criteria we followed in creating the website was to make the website easy to navigate and to display clearly where the photos were captured. The interactive map on the front page is very compatible with the web pages already implemented on Glacier National Park's website. Condensed pages focusing on regions of the park, similar to the Hiking the Trails page, can be available for people who know what region of the park they want to visit. The archive of images is also a very important feature of the proposed website. The easy to use functions to maneuver through the archived conditions is highly recommended. The drop down time and date menu is also recommended as visitors and park employees will now have the option of going the conditions from any date or time.

Some additional details that were not included in the proposed prototype website could include image location, temperature, pressure, wind, and other weather details associated with each image. Links to the Hiking the Trails page, shuttle schedules, camp sites, and special events could also be associated with the webpage. We also recommend that the park go through a data storage company to create the website.

## 6. Conclusion

Every year more people visit Glacier National Park, causing increased congestion in parking lots, hiking trails, and roadways. Parking lots fill up early in the morning, trails are crowded, and the overall visitor experience can be impacted by the overall congestion. The 2019 WPI Standalone Webcam Team prototyped an in depth solution to assist the park with traffic mitigation; a static-solar webcam system, a mobile webcam system, and a website to display real time traffic data. We showed how webcams can effectively monitor and provide information about parking lots and roadways to both visitors and park staff. The standalone webcam system and website meet the goal set by the 2019 draft of the Going to the Sun Road Corridor Management Plan Environmental Assessment, which is to “Develop a congestion app and mobile device friendly website using real time data.”

The team created an extensive heat map which clearly laid out areas of connectivity along the Going to the Sun Road. Once the heatmap was created, we completed an in depth testing of both the static and mobile webcam systems in the park, taking over 16,200 pictures and allowing the systems to run autonomously for over 150 hours. Our designed website then effectively displayed the images captured, alongside an in depth archive system, allowing access to any image from any date and time.

Overall, our team completed an in depth testing of a standalone webcam system in Glacier National Park, which in the future could be an important tool used by both visitors and park staff in an effort to mitigate traffic congestion in the park. We hope that Glacier National Park can benefit from and continue the research completed in this project. Hopefully, this webcam system can help reduce the workload of park staff and improve the visitor experience in the park.



## 7. References

- Adams, S. (2013). 4 steps to successful brainstorming .Retrieved from <https://www.forbes.com/sites/susanadams/2013/03/05/4-steps-to-successful-brainstorming/#4f100c8c5992>
- Barrameda, C., Rizzo, T., & Vose, T. (2018). *Congestion Management in Glacier National Park*. Unpublished Interactive Qualifying Project. Worcester Polytechnic Institute.
- Cromwick, M., Bruno, M., & Feng, Y. (2018). Feasibility of webcam implementation in acadia national park. Interactive Qualifying Projects (all Years), Retrieved from <https://digitalcommons.wpi.edu/iqp-all/5118>
- Cullinane, S. (1997). Traffic management in britain's national parks. *Transport Reviews*, 17(3), 267-279. doi:10.1080/01441649708716985
- Falcochio, J. C., & Levinson, H. S. (2015a). Overview of congestion relief strategies. In J. C. Falcochio, & H. S. Levinson (Eds.), *Road traffic congestion: A concise guide* (pp. 185-195). Cham: Springer International Publishing. doi:10.1007/978-3-319-15165-6\_14 Retrieved from [https://doi.org/10.1007/978-3-319-15165-6\\_14](https://doi.org/10.1007/978-3-319-15165-6_14)
- Falcochio, J. C., & Levinson, H. S. (2015b). Overview of mitigation strategies that reduce traffic demand. In J. C. Falcochio, & H. S. Levinson (Eds.), *Road traffic congestion: A concise guide* (pp. 281-284). Cham: Springer International Publishing. doi:10.1007/978-3-319-15165-6\_18 Retrieved from [https://doi.org/10.1007/978-3-319-15165-6\\_18](https://doi.org/10.1007/978-3-319-15165-6_18)
- Falcochio, J. C., & Levinson, H. S. (2015c). Overview of the causes of congestion. In J. C. Falcochio, & H. S. Levinson (Eds.), *Road traffic congestion: A concise guide* (pp. 35-37). Cham: Springer International Publishing. doi:10.1007/978-3-319-15165-6\_4 Retrieved from [https://doi.org/10.1007/978-3-319-15165-6\\_4](https://doi.org/10.1007/978-3-319-15165-6_4)
- Franz, J. (2019). Glacier park releases long-awaited sun road management plan. Retrieved from <https://flatheadbeacon.com/2019/09/06/glacier-park-releases-long-awaited-going-sun-road-management-plan/>
- Friesen, P. Glacier national park launches parking lot app. Retrieved from [https://missoulian.com/news/local/glacier-national-park-launches-parking-lot-app/article\\_f1007251-08e1-592b-895b-4042c5054ac2.html](https://missoulian.com/news/local/glacier-national-park-launches-parking-lot-app/article_f1007251-08e1-592b-895b-4042c5054ac2.html)

- Gabe, T. (2015). Effects of the October 2013 U.S. federal government shutdown on national park gateway communities: The case of Acadia National Park and Bar Harbor, Maine. *Applied Economics Letters*, 23(5), 1-5. doi:10.1080/13504851.2015.1071465
- Glacier National Park grapples with traffic. Retrieved from <https://www.usatoday.com/story/travel/destinations/2013/08/14/glacier-national-parks-s-huttles-traffic/2653981/>
- Glacier park sees second busiest July on record. (2018). Retrieved from <https://flatheadbeacon.com/2018/08/14/glacier-park-sees-second-busiest-july-record/>
- Glacier, Mailing Address: PO Box 128 West, & Us, MT 59936 Phone: 888-7800  
Contact. Operating hours & seasons - Glacier National Park (U.S. National Park Service). Retrieved from <https://www.nps.gov/glac/planyourvisit/hours.htm>
- Grisak, A. (2018). The glaciers of Glacier National Park: See them before they are gone. Retrieved from <https://www.greatfalls Tribune.com/story/life/2018/06/29/glaciers-glacier-national-park-montana-see-them-before-climate-change-melts-them/746022002/>
- Harmon, D., & Putney, A. D. (2003). *The full value of parks: From economics to the intangible*. Lanham, Md: Rowman & Littlefield Publishers.
- Helms, M. M., & Nixon, J. (2010). Exploring SWOT analysis – where are we now? *Journal of Strategy and Management*, 3(3), 215-251. doi:10.1108/17554251011064837
- Hollander, N., Yang, Y., & Zhu, M. (2019). *Implementation and Design of Webcam Systems for Traffic Monitoring in Acadia National Park*. Unpublished Interactive Qualifying Project. Worcester Polytechnic Institute.
- Keiter, R. B. (2010). The national park system: Visions for tomorrow. *Natural Resources Journal*, 50(1), 71-110.
- Lake, KIANNA GARDNER Daily Inter. (201909150500). Sun road plan eyes dramatic changes to parking, trail use. Retrieved from [https://www.dailyinterlake.com/local\\_news/20190915/sun\\_road\\_plan\\_eyes\\_dramatic\\_changes\\_to\\_parking\\_trail\\_use](https://www.dailyinterlake.com/local_news/20190915/sun_road_plan_eyes_dramatic_changes_to_parking_trail_use)
- Leon, C. J., De Leon, J., Arana, J. E., & Gonzalez, M. M. (2015). Tourists' preferences for congestion, residents' welfare and the ecosystems in a national park. *Ecological Economics*, 118, 21.

- Lock, D. (2001). Benchmarking. *International Journal of Project Management*, 19(4), 253-254. doi:10.1016/S0263-7863(99)00062-9
- Maps - glacier national park (U.S. national park service). Retrieved from <https://www.nps.gov/glac/planyourvisit/maps.htm>
- Miao, G., Zander, J., Sung, K. W., & Slimane, B. S. *Fundamentals of mobile data networks*. Cambridge University: Cambridge University Press.
- National Park Service. (a). Criteria for designation
- National Park Service. (b). Early settlers - glacier national park (U.S. national park service). Retrieved from <https://www.nps.gov/glac/learn/historyculture/early-settlers.htm>
- National Park Service. (c). History & culture - glacier national park (U.S. national park service). Retrieved from <https://www.nps.gov/glac/learn/historyculture/index.htm>
- National Park Service. (d). Quick history of the national park service (U.S. national park service). Retrieved from <https://www.nps.gov/articles/quick-nps-history.htm>
- National Park Service. (2018a). Quick history of the national park service. Retrieved from <https://www.nps.gov/articles/quick-nps-history.htm>
- National Park Service. (2018b). Statistical abstract 2017 (). Retrieved from <https://irma.nps.gov/DataStore/DownloadFile/600257>
- The national park system plan (1970). . Washington:
- National park system sees more than 330 million visits - office of communications (U.S. national park service). Retrieved from <https://www.nps.gov/orgs/1207/02-28-2018-visitation-certified.htm>
- National Park Trust. Map of national parks. Retrieved from <https://www.parktrust.org/map-of-national-parks/>
- National Parks Conservation Association. Background: The economics of national parks. Retrieved from <https://www.npca.org/articles/832-background-the-economics-of-national-parks>
- Newton, J. N., Newman, P., Taff, B. D., Shr, Y., Monz, C., & D'Antonio, A. (2018). If i can find a parking spot: A stated choice approach to grand teton national park visitors' transportation preferences. *Journal of Outdoor Recreation and Tourism*, doi:10.1016/j.jort.2018.04.001
- NPS. (2019). Going-to-the-sun road corridor management plan environmental assessment.

- Pletcher, K. National park service | definition, history, & facts. Retrieved from <https://www.britannica.com/topic/National-Park-Service>
- Reilly, P. Flathead county approves cell tower near glacier. Retrieved from [https://missoulian.com/news/local/flathead-county-approves-cell-tower-near-glacier/article\\_9d50d201-4917-5d1c-8929-abf99c255b20.html](https://missoulian.com/news/local/flathead-county-approves-cell-tower-near-glacier/article_9d50d201-4917-5d1c-8929-abf99c255b20.html)
- Reilly, P. (2018). For glacier national park visitors, government shutdown makes little difference. Chicago: Tribune Content Agency LLC.
- Roadwork continues in glacier national park (2018). . Amman: SyndiGate Media Inc.
- Soundscape / noise - glacier national park (U.S. national park service). Retrieved from <https://www.nps.gov/glac/learn/nature/soundscape.htm>
- Statista.com. National park service: Number of visitors 2010-2017 | statistic. Retrieved from <https://www.statista.com/statistics/206820/number-of-visitors-to-national-park-service-sites-since-2010/>
- The National Park Service. (2016). Water quality - glacier national park (U.S. national park service). Retrieved from <https://www.nps.gov/glac/learn/nature/waterquality.htm>
- Tripadvisor. (2019, ). Going to the sun road review page. Retrieved from [https://www.tripadvisor.com/Attraction\\_Review-g143026-d146551-Reviews-Going\\_to\\_the\\_Sun\\_Road-Glacier\\_National\\_Park\\_Montana.html](https://www.tripadvisor.com/Attraction_Review-g143026-d146551-Reviews-Going_to_the_Sun_Road-Glacier_National_Park_Montana.html)
- U.S. Geological Survey. (2019). Query form for the domestic united states and its territories . Retrieved from <https://geonames.usgs.gov/domestic/index.html>
- U.S. Geological Survey. (n.d.). What is a glacier? Retrieved from <https://www.usgs.gov/faqs/what-a-glacier>
- Upton, E., & Halfacree, G. (2014). Raspberry pi user guide John Wiley & Sons.
- Webcams - mount rainier national park (U.S. national park service). Retrieved from <https://www.nps.gov/mora/learn/photosmultimedia/webcams.htm>
- Webcams - yellowstone national park (U.S. national park service). Retrieved from <https://www.nps.gov/yell/learn/photosmultimedia/webcams.htm>
- wikipedia.org. (2019). List of mountains and mountain ranges of glacier national park. Retrieved from [https://en.wikipedia.org/wiki/List\\_of\\_mountains\\_and\\_mountain\\_ranges\\_of\\_Glacier\\_National\\_Park\\_\(U.S.\)](https://en.wikipedia.org/wiki/List_of_mountains_and_mountain_ranges_of_Glacier_National_Park_(U.S.))

Yogerst, J. (2019). A guide to glacier national park

. Retrieved from

<https://www.nationalgeographic.com/travel/national-parks/glacier-national-park/>

Zhang, K., & Batterman, S. (2013). Air pollution and health risks due to vehicle traffic.

Science of the Total Environment, 450-451, 307-316.

doi:10.1016/j.scitotenv.2013.01.074



## 8. Appendix

### 8.1 Appendix A: Mobile Webcam Source Code

#### autorun.sh

```
#!/bin/bash
# Test is the process is running using the if statement.
#su pii

# Kill existing python processes
killall python3

while true;
do
  if ! ps -ef | egrep '[g]pscamdaemon.sh' ;
  then
    echo "program gpscamdaemon is not running - run the program"

    /home/pi/gpscamdaemon.sh > /home/pi/gpscamdout.txt &
  else
    echo "program gpscam is running - nothing to do"
  fi

  if ! ps -ef | egrep '[f]tpdaemon.sh' ;
  then
    echo "program ftpdaemon is not running - run the program"
    /home/pi/ftpdaemon.sh > /home/pi/ftpdout.txt &
  else
    echo "program ftpdaemon is running - nothing to do"
  fi

  sleep 5
done
```

## gps-init.py

```
#!/usr/bin/python3

import serial
import subprocess
import time

print("Connecting to serial control device")
serial = serial.Serial("/dev/ttyUSB2")

print("Configuring GPRS")
# Due to a bug in the EC25, it is possible for ghost sessions to be left behind
# when the device restarts or encounters an error. These ghosts will prevent
# GPS readings from being taken and new GPS sessions from being created until
# they are killed.
serial.write("AT+QGPSEND\r\n".encode()) # Close any existing sessions
time.sleep(2)
serial.write("AT+QGPS=1\r\n".encode()) # Enable GPS
serial.close()

print("Starting GPS daemon")
subprocess.call(['sudo', 'killall', 'gpsd'])
subprocess.call(['sudo', 'gpsd', '/dev/ttyUSB1', '-F', '/var/run/gpsd.sock'])
#subprocess.call(['cgps', '-s'])

print("Done")
```

## main.py

```
from gps3 import gps3
from picamera import PiCamera
from time import sleep
import time
#from playsound import playsound
import csv
import math
from datetime import datetime

# Calculate the distance between two points on the surface of the earth
def haversine(c1, c2):
    R = 6372800 # Radius of earth in meters
    lat1, lon1 = c1
    lat2, lon2 = c2
    phi1, phi2 = math.radians(lat1), math.radians(lat2)
```

```

dphi = math.radians(lat2 - lat1)
dlambda = math.radians(lon2 - lon1)
a = math.sin(dphi/2)**2 + math.cos(phi1)*math.cos(phi2)*math.sin(dlambda/2)**2
return 2*R*math.atan2(math.sqrt(a), math.sqrt(1 - a))

def takepic(name,camera):
    camera.start_preview()
    sleep(.25)
    tstamp = datetime.now().strftime("%Y-%m-%d_%H-%M-%S")
    camera.capture('/home/pi/Desktop/webcam/pics/'+name+"."+tstamp+".jpg")
    camera.stop_preview()
    print('pic taken: '+name)
    return

def inrange(truelat,truelon,data_stream):
    c1 = (truelat,truelon)
    c2 = (float(data_stream.TPV['lat']),float(data_stream.TPV['lon']))
    dist = haversine(c1, c2)
    print("Distance is \033[33m{}\033[0m".format(dist))
    return dist < 10

# return ((abs(float(data_stream.TPV['lon'])-
truelon)<=.0001)and(abs(float(data_stream.TPV['lat'])-truelat) <= .0001))
def main(useftp = False ):
    # Parse the data points file
    pointfile = open('/home/pi/points.csv','r')
    csv_reader = csv.reader(pointfile)
    points = []
    for row in csv_reader:
        gpoint = {
            'lat': float(row[0]),
            'lon': float(row[1]),
            'name': row[2],
            'radius': float(row[3])
        }
    print("Added new point at \033[33m{}\033[0m, \033[33m{}\033[0m named \033[33m{}\033[0m with an
active radius of \033[33m{}\033[0m".format(gpoint['lat'], gpoint['lon'], gpoint['name'],
gpoint['radius']))
    points.append(gpoint)
    pointfile.close()
    camera = PiCamera()
    gps_socket = gps3.GPSDSocket()
    data_stream = gps3.DataStream()
    gps_socket.connect()
    gps_socket.watch()
    # Create the debug data output file for storing distance information
    fname = datetime.now().strftime("/home/pi/debug_%Y-%m-%d_%H-%M-%S.csv")
    debug_data_file = open(fname,'w')
    for new_data in gps_socket:
        if new_data:
            data_stream.unpack(new_data)
            if(data_stream.TPV['lon'] == 'n/a'):
                print('searching for gps signal...')
                continue
            print('Longitude = ',data_stream.TPV['lon'],' +/- ', data_stream.TPV['epx'], ' meters')
            print('Latitude = ', data_stream.TPV['lat'], ' +/- ', data_stream.TPV['epy'], ' meters')
            print('Time = ', data_stream.TPV['time'])
            print('GPS Speed = ', data_stream.TPV['speed'], ' +/- ', data_stream.TPV['eps'], ' m/s')
            print('=====')
            current_lat = float(data_stream.TPV['lat'])
            current_lon = float(data_stream.TPV['lon'])
            dist_data = []
            for point in points:
                c1 = (point['lat'],point['lon'])
                c2 = (current_lat,current_lon)
                dist = haversine(c1,c2)
                dist_data.append(str(dist))
                print("Point \033[33m{}\033[0m, dist \033[33m{:.2f}\033[0m".format(point['name'],
dist))

```

```

        if dist < point['radius']:
            print("Point matches!")
            takepic(point['name'], camera)
            break
    debug_data_file.write(', '.join(dist_data))
    debug_data_file.write("\n")
    debug_data_file.flush()

print('===GLACIER NATIONAL PARK MOBILE WEBCAM SYSTEM===')
main()

```

## ftp.py

```

import pysftp
import subprocess
from time import sleep
from pathlib import PosixPath
import os

#####
#####FTP LOGIN INFO#####
#####
USERNAME = 'REDACTED'
PASSWORD = 'REDACTED'

def getSignalStrength():
    return 999
    python3_command = "python2 /home/pi/Desktop/webcam/sigstr.py"
    process = subprocess.Popen(python3_command.split(), stdout=subprocess.PIPE)
    output, error = process.communicate() # receive output from the python2 script
    print(output.strip().decode('ascii'))
    strength = int(output.strip().decode('ascii')) #hacking
    return strength

photodir = PosixPath('/home/pi/Desktop/webcam/pics/')
#print(list(photodir.glob('*.jpg')))
#print(str(list(photodir.glob('*.jpg')))[0]))
while(True):
    print("main loop: checking for images")
    while list(photodir.glob('*.jpg')): #is there something in the list?
        print("something's in the list.")
        snapshot = list(photodir.glob('*.jpg'))
        print(snapshot)
        #main program loop: check for new images
        if (getSignalStrength() > -70):
            sftp = pysftp.Connection('nps-cams.wpi.edu', username=USERNAME, password=PASSWORD)
            print("connected")
            sftp.chdir('/datastorage/images/glacier/')
            print("changed directory")
            sftp.put(str(snapshot[0])) # upload first file in list to public/ on remote
            print("put file successfully")
            os.remove(str(snapshot[0])) # remove file from system
            print("removed file from local pc")
            #playsound(happy)
            sftp.close()
        else:
            print("signal strength not strong enough...")
            #playsound(sad)

    sleep(10)

```



## 8.2 Appendix B: Static-Solar Webcam Source Code

This code was provided to us by Nicholas Hollander of the 2019 Acadia Webcam IQP.

We have omitted setup scripts and configuration files.

camera.py:

```
#!/usr/bin/python3 -u

##
# camera.py - Extreme Webcam Controller 9000
#
# Written by Nicholas Hollander <nhhollander@wpi.edu>
# Written on 2019-05-03
#

from picamera import PiCamera
import datetime
import os
import config
import math
import time
import upload
import subprocess
import ec25

# Print something to separate the logs
datestr = datetime.datetime.now().strftime("%T on %F")
msg = "STARTING UP AT {}".format(datestr)
print("\n \033[1;33m\u2554{}\u2557".format("\u2550"*len(msg)))
print(" \u2551{}\u2551".format(msg))
print(" \u255A{}\u255D\033[0m\n".format("\u2550"*len(msg)))

#####
# SETUP #
#####

# Print the PID
print("My PID is \033[1;33m{}\033[0m".format(os.getpid()))
print("Kill with \033[1m~/scripts/kill_children.sh {}\033[0m".format(os.getpid()))
# Change the working directory
print("\033[1mChanging working directory...\033[0m")
os.chdir("/home/pi")
print("Working directory is \033[1m{}\033[0m".format(os.getcwd()))
print("\033[1mConnecting to EC25...\033[0m")
ec25.init()

# Read the configuration
print("\033[1mLoading Configuration...\033[0m")
if not config.read():
    print("\033[31mNo configuration loaded - terminating\033[0m")
    exit()

# Initialize EC25
print("\033[1mConnecting to EC25\033[0m")
ec25.init(config.config['ec25']['enable_gps'])

# Set up and connect to the camera
print("\033[1mSetting up camera...\033[0m")
camera = PiCamera()
camera.resolution = (

    config.config['camera']['resolution']['x'],
    config.config['camera']['resolution']['y'])
print("Using resolution to \033[1m{}\033[0m".format(camera.resolution))

# Get the interval
print("\033[1mConfiguring interval...\033[0m")
start_time = config.config['interval']['start_time']
stop_time = config.config['interval']['stop_time']
start_hour = math.floor(start_time / 60)
start_min = start_time % 60
stop_hour = math.floor(stop_time / 60)
stop_min = stop_time % 60
interval = config.config['interval']['interval']
print("Taking pictures every \033[1;33m{}\033[0m minutes, starting at \033[1;33m{:02d}:{:02d}\033[0m and
ending at \033[1;33m{:02d}:{:02d}\033[0m!".format(interval, start_hour, start_min, stop_hour, stop_min))
```



```

#####
# MAIN LOOP #
#####

while True:
    # Get the current time
    ctime = datetime.datetime.now()
    # Extract components of the time
    year = ctime.year
    month = ctime.month
    day = ctime.day
    hour = ctime.hour
    minute = ctime.minute
    second = ctime.second
    ttime = (hour * 60) + minute
    # Compare time to start of day and end of day bounds
    if ttime < start_time:
        # It's too early for this!
        time.sleep((start_time - ttime) * 60)
        continue
    elif ttime > stop_time:
        # It's too late for this!
        print("\033[35mIt's too late to be taking pictures!\033[0m")
        if config.config['power']['disconnect_at_night']:
            print("Disabling EC25 (Goodnight)")
            ec25.set_functionality(0)
        # Wait until midnight
        time.sleep(((24 * 60) - ttime) * 60)
        continue
    # Enable EC25 only if it is not already enabled
    if not ec25.functionality == 1:
        print("Enabling EC25")
        ec25.set_functionality(1)
    # Generate the timestamped filename
    fname = "data/{}-{:04d}-{:02d}-{:02d}_{:02d}-{:02d}-
{:02d}.jpg".format(config.config['capture']['name_base'],year,month,day,hour,minute,second)
    print("Saving image to \033[1m{}\033[0m".format(fname))
    camera.capture(fname)
    # Compress and annotate the image
    subprocess.run(['/home/pi/scripts/annotate.sh',fname,'{:04d}-{:02d}-{:02d}
{:02d}-{:02d}-{:02d}'.format(year,month,day,hour,minute,second),config.config['capture']['name_full']])
    # Upload the image and delete it (on successful upload)
    upload.upload(fname, True)
    print("Waiting \033[1m{}\033[0m seconds before taking next picture".format(interval * 60))
    time.sleep(interval * 60)

```

### 8.3 Appendix C: Cost Analysis

As a part of our final presentation, our team ran a rough cost analysis on manufacturing the webcams based on our own manufacturing costs as well as the rates of professionals for installation.

#### Static Camera

- Camera = \$300
- Solar Panel = \$65
- Battery = \$100
- Labor Cost = \$260 - \$340
- Maintenance = \$200/ yr

#### Mobile Camera

- Camera = \$450
- Labor Cost = \$260 - \$340
- Maintenance = \$200/ yr

## 8.4 Appendix D: Space Analysis

Assuming the cameras run for a three month season, the following is a brief analysis of how much space a web server would need to store the data from one season per year per camera:

Test Server: 15GB

Test image: 200KB

$15\text{GB} \times 1024 \text{ MB/GB} \times 1024\text{KB/MB} \div 200\text{KB/Image}$   
 $= 78,643 \text{ images}$

Static cam runs 8a - 4p: 8 hours

$8\text{h} / \text{day} \times 60 \text{ min/h} * 2 \text{ pictures} / \text{min} = 960 \text{ pics} / \text{day}$

$78,643 \text{ pics} / 960 \text{ pics/day} = 82 \text{ days}$

20 GB for 3 months of peak season for a static camera

The space the mobile camera takes up is variable depending on the number of points programmed into the GPS, as well as the frequency of the shuttles moving past the points.

Assuming a shuttle will run past each point around 9 times in one day and that there are 40 points along the route:

$200\text{KB/ Image} \times 9 \times 40 \text{ Images} / \text{Day} \times 90 \text{ days} = 6.48 \text{ GB per camera per season}$