



# SUSTAINABLE PAPER INSULATION FOR KAMBASHUS IN INFORMAL SETTLEMENTS OF NAMIBIA

---

AN ASSESSMENT OF THE THERMAL RESISTANCE, FLAMMABILITY, AND EFFICIENCY OF  
RECYCLED WASTE MATERIALS FOR INSULATING SHACKS IN KATUTURA



An Interactive Qualifying Project  
submitted to the faculty of  
WORCESTER POLYTECHNIC INSTITUTE  
in partial fulfillment of the requirements for the  
Degree of Bachelor of Science  
On 3 May 2012  
By  
Jonathan Cline  
Emily Domingue  
Emily Fournier  
Marco Villar

Submitted to:  
WPI Advisors: Svetlana Nikitina, Thomas Robertson  
Sponsor: The Men on the Side of the Road Project  
Liaison: Janet Wicks, Director of MSR

## ABSTRACT

---

The metal shacks of Katutura are unbearably hot in the summer and cold in the winter. The goal of this project was to develop sustainable paper insulation to improve thermal regulation in shacks. We conducted preliminary testing on fire safety, effective insulating materials, and production techniques. To develop a background of social and technical understanding, we researched low-cost insulation projects and interviewed several members of the community. In collaboration with Katutura residents and members of the Men on the Side of the Road Project, we developed an effective prototype of the sustainable paper insulation sheet. Finally, we provided recommendations for the Men on the Side of the Road Project to support continued research, large-scale testing, and further development of sustainable paper insulation.

## EXECUTIVE SUMMARY

---

The United Nations defines informal settlement areas (ISAs) as residences that lack at least one characteristic of decent housing including “adequate sanitation, water supply, durable housing or adequate living space.”<sup>1</sup> Worldwide, approximately 1 billion people reside in settlements that fall within these standards.<sup>2</sup> In Namibia, twenty-five percent of the population lives in informal settlements.<sup>3</sup> One of the largest of these informal settlements is Katutura, located on the outskirts of Windhoek. Residents of this informal settlement live in self-constructed shacks, called “kambashus,” made of corrugated zinc sheets nailed to a wooden frame. A major problem associated with living in these metal shacks is indoor temperature regulation. Since most residents do not have access to commodities such as electricity, it is difficult to deal with the extreme Namibian climate.

We worked with the Men on the Side of the Road Project (MSR), a non-profit organization established to “address the plight of unemployed men who congregate daily on the side of the road.”<sup>4</sup> Our purpose was to help MSR to develop the Paper Insulation Project. The aim of this project was to use recycled paper and woodchip materials to produce a cheap, fire-resistant, and sustainable insulation for local kambashus. The production and marketing of this insulation would also provide community members with a source of employment and income.

## METHODOLOGY

---

The Men on the Side of the Road organization requested a study on the feasibility of using recycled paper and woodchips as an insulation material. The goal of this project was to work collaboratively with Katutura residents to investigate feasible methods of developing community-based paper insulation for use in local kambashus. We developed the following objectives in order to achieve our goal:

1. Determine how Katutura residents currently construct and insulate their kambashus and if the cultural background of residents and the regional environment affect kambashu design

---

<sup>1</sup> "Slums and Informal Settlements," (2007).

<sup>2</sup> Mahbubur Rahman, "Sustainable Squatter Housing in the Developing World: Changing Conceptualization," *Archnet-IJAR : International Journal of Architectural Research* 5, no. 1 (2011), 143-159.

<sup>3</sup> The Shack Dwellers Federation of Namibia, *Community Land Information Program (Clip)-Profile of Informal Settlements in Namibia March 2009*, 2009.

<sup>4</sup> *Men on the Side of the Road Namibia*.

2. Determine the availability of resources, effectiveness of insulation in kambashus, and feasible production methods to assess the potential of producing paper insulation
3. Interpret test results to determine the most appropriate insulation mixture in terms of thermal properties, fire and water resistance, ease of production, cost, and community preference
4. Observe and analyze the production and marketing of MSR's Paper Block Project to apply similar techniques to develop the Paper Insulation Project

We considered Katutura residents and Men on the Side of the Road members as our key stakeholders. When developing our paper insulation, we considered the opinions and concerns of these groups as well as experts in specific fields to produce the most effective paper insulation. The following is a guideline of methods we used in the accomplishment of our objectives:

1. We conducted interviews with community members in order to determine residents' knowledge of insulation, how receptive they were to the project, and what aspects were most important to consider when producing a prototype.
2. We participated in the Paper Block Project to learn production and marketing techniques that we could apply to the Paper Insulation Project.
3. We created and tested four different paper mixtures for effectiveness in thermal regulation and flammability.
4. We researched further fireproofing methods for paper insulation sheets and made recommendations.
5. We conducted additional interviews to recommend better solutions for fire safety and waterproofing.
6. We designed and constructed a prototype of the paper insulation mold.



FIGURE 1: ASSISTING IN PAPER BLOCK PRODUCTION<sup>5</sup>

---

<sup>5</sup> Photographs by Emily Fournier March 2012.

## RESULTS

---

Through various methods of observation and experimentation, we have identified the criteria necessary for developing effective paper insulation. The following is an outline of our findings.

**Our research and feedback from the community showed that indoor temperatures are uncomfortable for residents, thus thermal regulation techniques, such as insulation, are necessary for kambashus in Katutura.**

After conducting fifteen interviews within the informal communities of Katutura, we found that almost all residents found indoor kambashu temperatures uncomfortable during the daytime, specifically, during the summer months. Some residents also found nighttime temperatures to be uncomfortably cold. Many interviewees explained various methods that they currently used to cool their shacks. Some of these methods included simply leaving their doors open, or decorating their walls with cloth to alleviate some of the heat conducted by the corrugated metal roof. However, none of the residents we interviewed had used insulation in their kambashu.

**Knowledge, personal preference, and income affect kambashu design and improvements.**

After comparing observations of different kambashus, we determined that Katutura residents construct their houses using similar materials and design. Personal preference and the knowledge of the shack builder are factors that contribute to design modifications. The income of the family plays a role in the quality of the shack as well.

**Most residents already apply foam glue, weatherproofing membrane and paint, and other waterproofing methods in their kambashus.**

After observing multiple kambashus and conducting interviews within the informal settlements, we found that approximately half the residents already have the means to waterproof their shacks.

**Weatherproofing is necessary for kambashu roofs prior to installing insulation to ensure water does not increase susceptibility to fire and decrease insulating properties of the insulation.**

If a roof leaks after the installation of insulation then it can cause it to fall apart rendering it ineffective and more susceptible to fire. The accumulation of moisture within the insulation can also create a suitable environment for mold to grow, which creates an additional health hazard for inhabitants.

**We confirmed that the materials used for the Paper Block Project are effective insulating materials and are cheap and sustainable resources.**

The recycled paper and woodchips utilized in the production of paper blocks are acquired from local offices around Windhoek and the Windhoek Vocational Training Centre (WVTC) respectively at no cost to the Men on the Side of the Road. Therefore, these materials are both sustainable and cheap. In order to adapt the blocks to our Paper Insulation Project we designed a new mold in order to make thinner sheets.

**We found that installing insulation would be more cost effective than applying heat reflective paint to the roof of kambashu.**

Heat reflective paint costs N\$336.99 for a 5-liter container of paint. When more than one 5-liter container of paint is needed, insulation is a more cost effective solution to reducing the temperature inside a standard-size kambashu.

**We found that in order to produce the most efficient insulation product we should reduce the thermal gaps between the sheets of insulation.**

We designed a new mold in cooperation with Central Welding Works. The purpose of the new mold was to reduce thermal gaps between sheets of insulation.

**The paper insulation mixture with a ratio of 50 percent less paper and the same amount of wood chips as the standard mixture was the most effective at regulating internal temperature.**

We tested four different paper mixtures using small-scale kambashu models. The purpose was to determine which mixture kept the internal temperature of the kambashu the lowest during the day and the highest at night compared to a control. The 50 percent less paper mixture was also the most preferred by the community and the easiest to produce.

**The thickness of the insulating material does not greatly affect its insulating properties.**

We found that the thinner insulation was slightly more effective at regulating internal kambashu temperature, but the difference in effectiveness was so small that we considered it negligible.

**Flammability testing of the paper insulation showed that none of the four insulation mixtures ignited as quickly or as easily as anticipated.**

After holding a welding torch to a block of each different mixture, the 50 percent more paper mixture remained lit the longest at 7.1 seconds. The mixture that burned for the shortest amount of time was the 50 percent less paper mixture at 3.5 seconds.

**MSR members would benefit from using large-scale demonstrations to improve marketing.**

After conducting multiple interviews, we found that community members would like to see the functionality of the product being sold. Once residents have seen the how well the product works sales

will likely increase. For that reason, MSR members would benefit from marketing the paper insulation using large-scale demonstrations.

## RECOMMENDATIONS

---

After multiple field visits, interviews, and experiments, our group has established the following recommendations for the Men on the Side of the Road Project to implement a sustainable Paper Insulation Project in Katutura, Namibia.

**We recommend that MSR perform proper fire testing on the 50 percent less paper insulation mixture.**

We will bring six to ten samples of the 50 percent less paper insulation to the Fire Protection Engineering Department at Worcester Polytechnic Institute to obtain certified fire classifications of the insulation. The fire classifications will ensure MSR that it is selling a product that is safe for application in kambashus.

**We recommend that MSR produce a fully functional mold and press for the paper insulation based on our prototype design.**

We have created preliminary designs for a new paper insulation mold and press. MSR should work in partnership with Cristo Coetzee of CMW Welding to create a functional mold and press to begin production of paper insulation sheets.

**We recommend that MSR perform continued thermal experimentation through large-scale testing.**

MSR members should test the 50 percent less paper insulation in full-size kambashus over a period of at least a year. This would allow the insulation to be tested during all four seasons. MSR will also be able to collect data on thermal comfort throughout the year.

**We recommend MSR require that a kambashu is waterproof prior to the installation of the paper insulation.**

We have determined that most processes of waterproofing the insulation are too expensive for use in kambashus. However, cost effective methods of waterproofing the kambashu such as foam-forming glue, bottle cap washers, proper construction techniques, and waterproofing paint and membrane should be utilized. If a kambashu owner could not waterproof his kambashu prior to insulation installment, then MSR could offer a weatherproofing service.

**We recommend that MSR members localize the sale of the paper insulation within their respective communities, develop a demonstration for its sale, and produce informational pamphlets as a means of marketing.**

MSR members should create shops or central locations within Katutura communities to sell paper insulation. By doing so, MSR members can market the insulation and the organization more effectively. Creation of a large-scale demonstration and informational pamphlets will also improve MSR's marketing techniques.

**We recommend that MSR practice community driven implementation in the Paper Insulation Project and future projects.**

Community feedback is invaluable for this project. By involving the community in all aspects of this project, MSR can ensure that community members receive the Paper Insulation Project positively.



## ACKNOWLEDGEMENTS

---

We would like to thank the following individuals and organizations for their support and contribution to the success of this project.

- The Men on the Side of the Road Project for sponsoring our project, providing us with a work space, testing supplies, and other resources necessary to complete this project.
- The director of the Men on the Side of the Road, Mrs. Janet Wicks, for her continued ideas, enthusiasm and support throughout the project.
- Mr. Pius Shambabi, the Paper Block Project coordinator, and Ms. Magdalena Namwandi, an intern at MSR, for their assistance in translating, help in understanding the cultural impacts of our project, and help in developing our project goals and objectives.
- Mr. Harald Schutt who discussed fireproofing techniques and other background information pertinent to the development of paper insulation.
- Mr. Hendrik Ehlers for sharing his project, Namibia Solar Bottle Program, and discussing other ideas and aspects of our project.
- Mr. Cristo Coetzee, from CMW Welding, for assistance in constructing and designing a prototype insulation mold.
- Claudius from the Habitat Research and Development Centre Welding School for his assistance in conducting our burn tests.
- Residents of Katutura who kindly invited us into their Kambashus and allowed us to interview them and take pictures to better understand the background and application of our project.
- Professor Thomas Robertson, Professor Svetlana Nikitina, Professor Robert Hersh, and Christine Drew of Worcester Polytechnic Institute for their efforts in challenging us to think about the full scope of this project, and for their continued guidance and support throughout this project.
- Worcester Polytechnic Institute and the Polytechnic of Namibia for making our experience in Namibia and this project possible.

## AUTHORSHIP

---

**Abstract and Executive Summary:** Written by Jonathan Cline and Emily Fournier; Edited by Emily Domingue

**Chapter 1:** Introduction: Written by Emily Domingue and Emily Fournier; Edited by Jonathan Cline, Emily Fournier and Marco Villar

**Chapter 2:** Background: Written by Jonathan Cline, Emily Domingue, Emily Fournier and Marco Villar; Edited by Jonathan Cline, Emily Fournier, and Marco Villar

**Chapter 3:** Methods: Written by Emily Domingue and Emily Fournier; Edited by Emily Domingue and Marco Villar

**Chapter 4:** Results and Analysis: Written by Jonathan Cline and Marco Villar; Edited by Emily Domingue and Emily Fournier

**Chapter 5:** Conclusions and Recommendations: Written by Jonathan Cline and Marco Villar; Edited by Emily Domingue and Emily Fournier

All four members reviewed and edited each section and contributed to the Appendices.

## TABLE OF CONTENTS

---

Abstract .....	ii
Executive Summary .....	iii
Acknowledgements .....	ix
Authorship .....	x
Chapter 1: Introduction .....	15
Chapter 2: Background.....	18
I. Unemployment and the Rise of Informally Settled Areas in Namibia.....	19
II. MSR’s Mission to Address Unemployment .....	22
III. Need for Insulation in Low-Cost Housing.....	24
IV. Barriers to Low-Cost Insulation in Katutura .....	26
V. Global Case Studies on Low-Cost Insulation .....	29
Chapter 3: Methodology .....	31
Objective I.....	31
Objective II.....	35
Objective III.....	40
Objective IV.....	41
Chapter 4: Results and Discussion .....	42
I. Analysis of the Need for Insulation.....	42
II. Kambashu Design and Maintenance Techniques.....	44
III. Materials and Production of Insulation.....	48
IV. Comparison of Insulation Mixtures.....	50
V. Improvements to Marketing Techniques .....	56
CHAPTER 5: Conclusions and Recommendations .....	58
I. Next Steps for the Development of Paper Insulation .....	58
II. Marketing Strategies for the Paper Block and Paper Insulation Projects.....	61
III. Growth and Implementation Techniques for MSR .....	63
IV. Recommendations for Future WPI Projects .....	64
V. Technology and Society.....	66
Bibliography .....	68
Appendices.....	70
Appendix A: MSR History and Mission .....	70
Appendix B: Community and MSR Member Interview Templates.....	73
Appendix C: Project Timeline .....	76

Appendix D: Steps for Making Paper Blocks ..... 77  
Appendix E: Photo Journal ..... 81  
Appendix F: Namibia Solar Bottle Program ..... 89  
Appendix G: Thermal Testing Results ..... 90  
Appendix H: Fire Testing Results ..... 102  
Appendix I: Insulation Testing Ranking Sheets ..... 103  
Appendix J: Insulation Information Handout ..... 105  
Appendix K: Insulation Survey for MSR Members ..... 106  
Appendix L: Community Interview Summaries ..... 107  
Appendix M: Preliminary Mold Design ..... 112  
Appendix N: Prototype Mold Design ..... 114

## TABLE OF FIGURES

---

Figure 1: Assisting in Paper Block Production .....	iv
Figure 2: Map of the City of Windhoek, Namibia Showing Katutura April 27, 2012 .....	18
Figure 3: Urban and Rural Population Distribution in Namibia from 1936 to 2001 .....	20
Figure 4: Interior and Exterior of Shacks in Katutura.....	22
Figure 5: MSR Member Holding His Member Card.....	23
Figure 6: Monthly Average Max and Min Outdoor Temperatures and Precipitation in Windhoek, Namibia.....	25
Figure 7: Percentage of Subjects Who Felt Comfortable at a Given Indoor Temperature in South Africa.....	26
Figure 8: Aser's Kambashu in One Nation, Katutura .....	32
Figure 9: Pius' Kambashu in Hakahana, Katutura.....	33
Figure 10: Wooden Kambashu Frame .....	35
Figure 11: Completed Small-Scale Kambashus.....	36
Figure 12: Paper Block Mold.....	37
Figure 13: Experimental Set-Up for Thermal Properties Testing .....	38
Figure 14: One Nation Kambashus vs. Hakahana Kambashus.....	45
Figure 15: Multiple Waterproofing Techniques .....	46
Figure 16: Prototype Insulation Mold and Sheets .....	50
Figure 17: Thermal Test Results for 50 Percent Less Paper Insulation .....	52
Figure 18: Thermal Test Results for Thick Insulation vs. Thin Insulation .....	53
Figure 19: Fifty Percent Less Paper Smoke and Smoldered Block .....	54

## LIST OF TABLES

---

Table 1: Material Costs for Kambashu Supplies from Build It (2012).....	47
Table 2: Cost Analysis of Heat Reflective Paint Compared to Paper Insulation .....	49
Table 3: Summary of Average Temperature Difference Between the Insulated Shack and the Control .....	51

---

## CHAPTER 1: INTRODUCTION

---

The United Nations defines informal settlement areas (ISAs) as residences that lack at least one characteristic of decent housing including “adequate sanitation, water supply, durable housing or adequate living space.”<sup>6</sup> Worldwide, approximately 1 billion people reside in settlements that fall within these standards.<sup>7</sup> This problem is most prominent in Africa where over 187 million people live in slums; this is nearly twenty percent of the world’s total ISA residents. These settlements are growing at such an alarming rate due to the rapid urbanization of this region. Presently, 40 percent of Africans live in urban areas. Researchers expect this number to increase another 10 percent by 2025.<sup>8</sup> As urban areas begin to grow, so do informal settlements on the outskirts of the cities. The growth of informal settlements poses several problems such as poor health and education systems, limited access to electricity and running water, a high incidence of crime, and environmental conditions such as extreme heat.

In Namibia, twenty-five percent of the population lives in informal settlements.<sup>9</sup> High unemployment rates, rapid urbanization, and lack of low-income housing in cities have all contributed to the growth of these informal settlements. Nowhere is this more true than in Windhoek. As the capital and a major urban area of Namibia, it has attracted people from many regions and backgrounds in the search of better opportunities. The city has steadily grown from 185,000 in 1995 to 350,000 in 2009. This has led to the expansion of several informal settlements.<sup>10</sup> Katutura, a region northwest of Windhoek, contains the city’s largest informally settled area. Residents of the informal settlement in Katutura live in self-constructed shacks, called “kambashus,” made from corrugated zinc sheets and a wooden frame. Because informally settled areas are unplanned, most of the shacks are missing essentials such as electricity, proper sanitation, and methods for temperature regulation.

Indoor temperature regulation is a major challenge to the living conditions within kambashus. Because corrugated zinc is a good conductor of heat, the shacks become hotter than the outdoor

---

<sup>6</sup> "Slums and Informal Settlements," (2007).

<sup>7</sup> Mahbubur Rahman, "Sustainable Squatter Housing in the Developing World: Changing Conceptualization," *Archnet-IJAR : International Journal of Architectural Research* 5, no. 1 (2011), 143-159.

<sup>8</sup> Oppenheimer and Spicer, 2011.

<sup>9</sup> The Shack Dwellers Federation of Namibia, *Community Land Information Program (Clip)-Profile of Informal Settlements in Namibia March 2009*, 2009.

<sup>10</sup> Ibid.

temperatures during the day and rapidly lose heat at night. From October to April, temperatures in Windhoek can reach as high as 40 degrees Celsius during the day and drop as low as 5 degrees Celsius at night in the winter months.<sup>11</sup> Insulating these shacks is one approach for improving thermal comfort during both the hotter and cooler times of the day or year. Previous studies conducted in South Africa and Northern Pakistan have shown that using insulation can improve thermal regulation within a dwelling and is more cost effective than heating and cooling methods such as electric powered devices or firewood.<sup>12</sup> Additionally, projects in South Africa have shown that even a four to six degree temperature reduction from low-cost insulation was effective in significantly improving thermal comfort.<sup>13</sup> Our research focused on assessing the feasibility and safety of implementing paper insulation in kambashus to improve thermal comfort.

We completed this project in partnership with our sponsor, Janet Wicks, the director of the Men on the Side of the Road Project in Katutura, Namibia. The Men on the Side of the Road Project (MSR) is an organization that originated in South Africa, and later in Katutura to “address the plight of unemployed men who congregate daily on the side of the road.”<sup>14</sup> With evidence of the extreme need for temperature regulation in homes within the informal settlements of Katutura, MSR is interested in researching applications of paper insulation to improve these conditions and to further promote employment in the community. We developed the insulation sheets with similar materials and molds as those utilized in MSR’s Paper Block Project, a project that creates blocks out of shredded paper and sawdust as an alternative to firewood.

The goal of this project was to work with Katutura residents and MSR to investigate feasible methods of developing community-based paper insulation for shacks in the informal sector. The purpose of community-based insulation is to develop, with the input of the community, an insulation product that Katutura residents will both produce and use. To accomplish this goal, we conducted fieldwork in Katutura to identify how residents typically constructed and insulated their shacks, worked with paper brick makers to learn how to adapt their techniques to making insulation, and interacted with local residents to understand from their perspective the technical and social dimensions of the

---

<sup>11</sup> The Shack Dwellers Federation of Namibia, *Community Land Information Program (Clip)-Profile of Informal Settlements in Namibia March 2009*, 2009.

<sup>12</sup> E. H. Mathews, S. Weggelaar and S. L. van Wyk, "The Development and Testing of Low-Cost Insulation for Shacks," *Energy and Buildings* 29, no. 3 (1, 1999), 307-313. doi:10.1016/S0378-7788(98)00040-1.

<sup>13</sup> P. B. Taylor et al., "The Effect of Ceiling Insulation on Indoor Comfort," *Building and Environment* 35, no. 4 (2000), 339-346.

<sup>14</sup> "Men on the Side of the Road Namibia" <http://www.msr.org.na/> (accessed January 20, 2012).



project. Furthermore, we used samples and small-scale testing to evaluate paper as an insulating material. Based on our findings, we were able to recommend to the Men on the Side of the Road Project further testing methods, marketing strategies, production strategies, techniques for addressing water damage, and techniques for addressing fire concerns of the paper insulation.

We hope our research will help MSR successfully develop an insulation that will improve the extreme thermal conditions within kambashus in Katutura. Through the help of the Men on the Side of the Road Project, we hope that we can implement the Paper Insulation Recycling Project to employ MSR members who sell the paper insulation sheets and help the members to develop skills essential for future employment opportunities.

## CHAPTER 2: BACKGROUND

In this Chapter, we addressed the following four topics:

- I. The causes of unemployment throughout Namibia and its effects on the people who live in informal settlements
- II. The goals of the Men on the Side of the Road Project and how this project could assist in creating new employment opportunities
- III. The need for low-cost insulation for kambashus in Namibia
- IV. The built environment and barriers to low-cost insulation
- V. Projects conducted globally that focus on low-cost insulation for corrugated metal shacks



FIGURE 2: MAP OF THE CITY OF WINDHOEK, NAMIBIA SHOWING KATUTURA APRIL 27, 2012<sup>15</sup>

<sup>15</sup> *Map of Windhoek, Namibia*. 2012. Photograph. Google. 27 April 2012.

## I. UNEMPLOYMENT AND THE RISE OF INFORMALLY SETTLED AREAS IN NAMIBIA

---

For the past two decades, Namibia's unemployment rate has steadily risen. At 51.2 percent, the country currently ranks eighth in the world for highest unemployment rates.<sup>16</sup> The main reason for this problem is the lack of job opportunities and a qualified work force. This stems from a lack of skill development opportunities and training programs. Another area of concern, specifically in the past few years, is Namibia's agriculture sector. Poor weather conditions during the past few growing seasons have greatly affected this market. Prices for agricultural produce on the international market have decreased as well. These conditions have led to a decrease in employment opportunities in agriculture. Recent mine closures have also added to the problem. As of 2008, these two issues have been key contributors to job loss.<sup>17</sup>

The Namibian people have varying sources of income. A 1996 study conducted to analyze income sources in Namibia showed that about 42 percent had no income, 47 percent were paid in wages, and about 11 percent had pensions as a source of income.<sup>18</sup> Compiled regional data also showed that in Khomas, the region in which Windhoek is located, the number of people paid in wages was 70 percent and only 25 percent had no source of income.<sup>19</sup>

According to the Namibia Labour Force Survey of 2008, only 22.4 percent of Namibians gained income through farming or animal rearing while 47.7 percent were paid in wages and through business activities.<sup>20</sup> The lower unemployment rate and growing job opportunities present in urban areas has stimulated migration from rural areas to urban cities.<sup>21</sup> Figure 3 depicts the transition of rural to urban migration.<sup>22</sup>

---

<sup>16</sup> CIA 2008, 22 February 2012.

<sup>17</sup> "NAMIBIA: Employment Survey," *Africa Research Bulletin: Economic, Financial and Technical Series* 47, no. 9 (2010), 18835A-18835B. doi:10.1111/j.1467-6346.2010.03492.x.

<sup>18</sup> Alice Jarvis et al., *Atlas of Namibia*, Second Edition ed. (Cape Town, South Africa: David Philip Publishers, 2003), 200.

<sup>19</sup> Ibid.

<sup>20</sup> Ministry Labour and Social Welfare, *Namibia Labour Force Survey 2008*.

<sup>21</sup> *NAMIBIA: Employment Survey*, 18835A-18835B.

<sup>22</sup> Jarvis et al., *Atlas of Namibia*, 200.

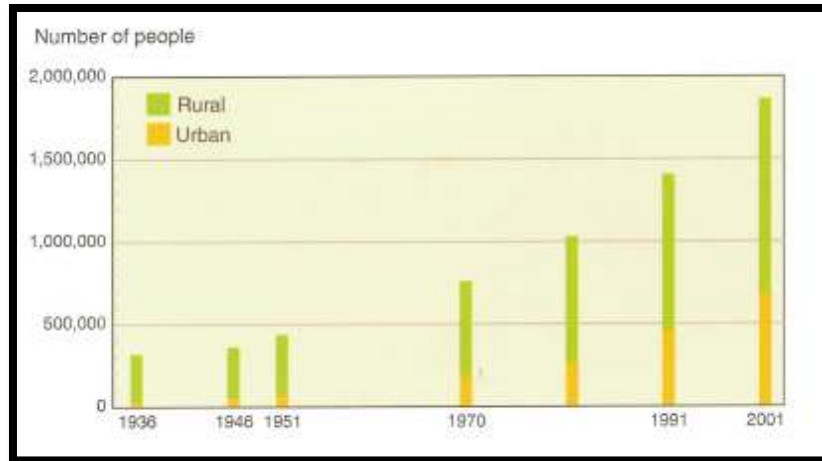

FIGURE 3: URBAN AND RURAL POPULATION DISTRIBUTION IN NAMIBIA FROM 1936 TO 2001<sup>23</sup>

The migration of Namibians from rural areas to cities in search of job opportunities caused another problem: insufficient housing. Over the past few decades, insufficient housing forced many rural migrants to reside in Informally Settled Areas (ISAs).<sup>24</sup> ISAs are areas of government or privately owned land on the outskirts of a city settled without formal permission. Government and city planning does not exist to accommodate facilities and services for ISAs, worsening conditions of these settlements.<sup>25</sup> Because inhabitants do not have ownership of the land, eviction is possible if someone purchases the land. As more and more people migrate to urban areas in search of better education, healthcare, and job prospects, ISAs are steadily growing in size. In 2002, estimates showed that over half of city dwellers in sub-Saharan Africa live in ISAs.<sup>26</sup> Many residents of Katutura moved to the city in search of employment, but lacked an affordable place to live. Thus, the ISA of Katutura developed, and instability shapes the conditions under which Katutura residents build their homes.

Globally, informal settlements that are able to overcome barriers of poor funding, environmental hazards, and permanent land-use regulations tend to improve over time. Community members make improvements to their shacks for aesthetic and functional advances. Often, roofing materials are improved, leaks patched, and walls made more stable. The addition of personal touches is also common to improve aesthetic appeal. In 2002, several sub-Saharan African cities such as Lagos,

<sup>23</sup> Alice Jarvis et al., *Atlas of Namibia*, Second Edition ed. (Cape Town, South Africa: David Philip Publishers, 2003), 200.

<sup>24</sup>Lindsay Wright, Elizabeth Norgard and Christopher Bean, *Energy Efficiency in Low-Cost Housing* (Worcester Polytechnic Institute: 2003).

<sup>25</sup> Middleton and Miller 2008, 134-165.

<sup>26</sup> *ibid.*

Nigeria; Addis Ababa, Ethiopia; Nairobi, Kenya; Johannesburg, South Africa; Mbabane, Swaziland; and Kumasi, Ghana, began the City Without Slums campaigns. These campaigns produced slum upgrading policies and plans, and undertook reforms and resources to develop current informal sectors.<sup>27</sup> One study states that if other cities realize such gains, then by 2025, over half of the African population will be living in cities, with over 65 percent of the city dwellers in developed areas, not ISAs.<sup>28</sup> This level of advancement within ISAs could allow for a receptive market for an insulation product.

Currently, nearly 25 percent of the entire Namibian population resides within informally settled areas.<sup>29</sup> One of the largest ISAs in Namibia is in the township of Katutura, located on the outskirts of the capital city Windhoek. The population of Katutura accounts for nearly two-thirds of the total population in Windhoek.<sup>30</sup> In the Otjiherero language, Katutura means, “we do not have permanent habitation.” The town council owns the majority of the land in Katutura and current residents occupy the land without an agreement.<sup>31</sup>

During the apartheid era, Katutura was a “new location” for the segregation of black Africans in Windhoek. Katutura has now become a home and cultural center for those looking for employment. Men on the Side of the Road Project successfully implemented their programs and mission in Katutura because of the surplus of unemployed men in need of training and support to find full time employment.

Residents of Katutura have already begun to develop their community and make improvements to their housing. Figure 4 shows a home in Katutura with aesthetic and functional improvements. Residents filled roof gaps with foaming glue in an effort to make walls and roofing more stable and secure.<sup>32</sup> Research shows the need for programs aimed at fostering employment opportunities and promoting further development in Katutura. The Men on the Side of the Road office is centrally located in Katutura so that members can easily access the resources offered. This is an ideal

---

<sup>27</sup> Middleton and Miller 2008, 134-165.

<sup>28</sup> Ibid.

<sup>29</sup> The Shack Dwellers Federation of Namibia, *Community Land Information Program (Clip)-Profile of Informal Settlements in Namibia March 2009*.

<sup>30</sup> Ibid.

<sup>31</sup> Wade C. Pendelton, *Katutura: A Place Where we Stay: Life in a Post-Apartheid Township in Namibia* [This book from], Vol. 65 (Windhoek, Namibia: Ohio University for International Studies, 1993), 217.

<sup>32</sup> Middleton and Miller 2008, 134-165.

location for the research of this project because our group worked directly with members and conducted observations and interviews in the community.



FIGURE 4: INTERIOR AND EXTERIOR OF SHACKS IN KATUTURA<sup>33</sup>

## II. MSR'S MISSION TO ADDRESS UNEMPLOYMENT

---

Each day hundreds of Oshiwambo men congregate at sites on the side of the road waiting for anyone who is willing to offer them a day's work.<sup>34</sup> The odd jobs are necessary for the continued welfare of these men and their families. The Men on the Side of the Road Project (MSR) is an organization that works to address the problem of unemployment in Windhoek by assisting the unemployed in developing skills to gain long-term employment.

Founded in Katutura in 2007 MSR works in collaboration with central and local governments and businesses that aspire to serve as a resource for job and training opportunities for unemployed Namibians.<sup>35</sup> The end goal for these programs is for members to develop a sense of self-sustainability that will greatly increase their chances of finding employment. Most MSR members are residents of Katutura or outlying informal settlements, but anyone can join. The organization helps members obtain employment by training and assisting in the placement of reliable and skilled laborers in more consistent jobs. The Men on the Side of the Road Project builds relationships with companies that need skilled and semi-skilled workers as well as provide their members with skill development and training programs, which will help them succeed in the job market.

MSR is different from other organizations in the area. Admission into the organization is free whereas members must pay an admission fee to participate in training programs and job placement

---

<sup>33</sup> Photographs by Janet Wicks February 2012.

<sup>34</sup> Men on the Side of the Road Namibia.

<sup>35</sup> Ibid.

organizations, such as Katutura Youth Enterprise Centre (KAYEC) and the Windhoek Vocational Training Centre (WVTC). Potential MSR members must complete an eight-hour life skills class in order to access the resources that MSR offers. Upon completion of the program, MSR adds the member's information to the database and gives them a photo membership card that identifies their proficient skills. Members can walk into the center and utilize anything that MSR has to offer. This includes training and skill development programs, access to computers and a fax machine, listings of current job openings, newspapers to assist in job searches, and advice from any of their knowledgeable staff.<sup>36</sup>



FIGURE 5: MSR MEMBER HOLDING HIS MEMBER CARD<sup>37</sup>

In the event that MSR does not offer a program that members are interested in, the organization has funds to send twenty individuals to KAYEC each year. At each community meeting, Janet Wicks, the director of MSR in Katutura, encourages members to take advantage of this opportunity. Some of the programs offered elsewhere are truck driving, plumbing, tiling, small engine maintenance and repair, painting, and bricklaying.<sup>38</sup> MSR also offers members the opportunity to participate in any of its on-going projects.

One of MSR's current projects is the Paper Block Project. This project allows members to create paper blocks from recycled waste paper and sawdust. Mr. Pius Shambabi is the coordinator of the Paper Block Project. Magdalena Namwandi, an intern from the University of Namibia, assisted Pius in coordinating the Paper Block Project. MSR receives the recycled paper from Envirochance, a partner that collects the waste paper from local businesses and shreds it. They acquire the sawdust from the WVTC. These blocks are very inexpensive to make because they are produced using waste materials. MSR is not only concerned about making sure that its projects are low-cost and profitable

---

<sup>36</sup> Men on the Side of the Road Namibia.

<sup>37</sup> Ibid.

<sup>38</sup> Ibid.

ventures for its members, but environmentally conscious as well. MSR's projects utilize recycled materials in the production process to promote sustainable efforts.

MSR members market the paper blocks as an alternative fuel source to firewood, which for many Katutura residents is an expensive and rare commodity.<sup>39</sup> Anyone caught cutting down a tree is arrested and may be sent to jail for up to one year. Due to this, paper blocks can assist in crime prevention and preserving the environment. This project stimulates employment opportunities not just through the production of these blocks, but by selling them. They receive a stipend of N\$8 for simply making the blocks, but can make an additional N\$1 per block by selling them in the community. By teaching MSR members to produce the blocks and sell them within the communities in which they live, members are able to acquire skills for self-employment, as well as a reliable source of income.

Since 2008, MSR has connected approximately 200 people each year with job opportunities. In January to April of 2011, over 300 visitors to the MSR office received assistance in undertaking job searches.<sup>40</sup> The Paper Block Project currently employs approximately ten people who produce and sell the blocks. Members of this project can come to the office and produce blocks, with the assistance of Pius, whenever they desire. For more information on the exact process of making these blocks, see Appendix D. MSR hopes to expand this project by utilizing the waste paper in other products. The project they have proposed is to make insulation from waste paper for the kambashus. This project, if determined to be feasible, will employ MSR members in a similar fashion to that of the Paper Block Project.

### III. NEED FOR INSULATION IN LOW-COST HOUSING

Insulating low-cost houses, primarily those made of corrugated zinc sheets and wooden frames, is an effective but complex approach to improving indoor thermal comfort. The climate in Namibia, coupled with the high thermal conductivity of corrugated zinc, causes significant daily indoor temperature fluctuations. In the winter, May to September, the daytime temperature is approximately 18 to 25 degrees Celsius, but can drop as low as 5 degrees Celsius at night. In the summer, October to April, daytime temperatures can reach 40 degrees Celsius, with cooler temperatures at night. Figure 6 depicts the average monthly maximum and minimum temperatures in Windhoek. Namibia experiences an arid environment nearly year round. In the sporadic rainy season, November to March, an average of

---

<sup>39</sup> Men on the Side of the Road Namibia.

<sup>40</sup> Ibid.



30-92 millimeters of rain falls in the central and northern regions. Due to the arid climate, humidity is usually very low and there are frequent, prolonged periods of drought.<sup>41</sup> The harsh heat and dry atmosphere leave residents of kambashus in Katutura susceptible to extreme indoor temperature fluctuations.

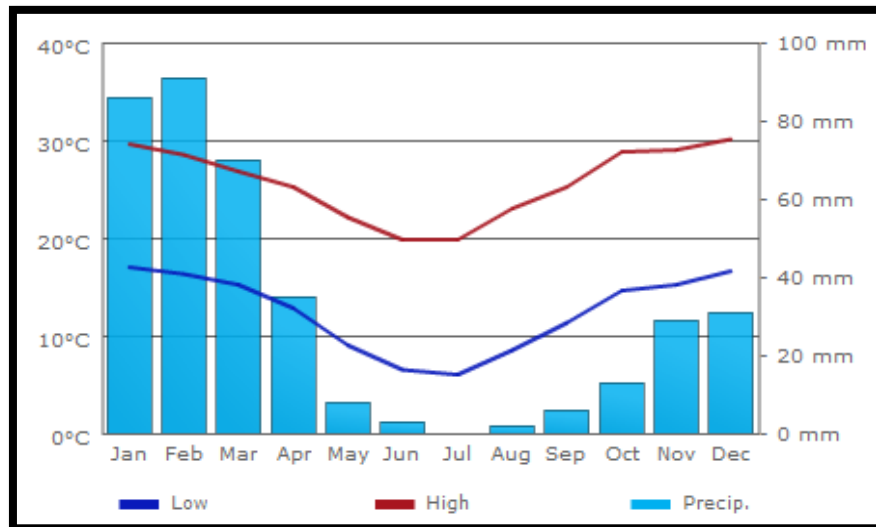

FIGURE 6: MONTHLY AVERAGE MAX AND MIN OUTDOOR TEMPERATURES AND PRECIPITATION IN WINDHOEK, NAMIBIA<sup>42</sup>

Many locals describe the shacks in the informal settlements of Katutura as oven-like. A resident of Havana, a neighborhood in Katutura, described the conditions in the kambashu as too hot and expressed several times that kambashu inhabitants are suffering because of it. During the day, the temperature within shacks can exceed the outdoor temperatures, as the sun beats down on the thin metal walls. During winter nights, however, the shacks become refrigerator-like. Due to high thermal conductivity of zinc, the shacks quickly lose the heat gained during the day, lowering the shack temperature to the frigid evening conditions. Regulating temperature change within the shacks can greatly improve the living conditions and indoor thermal comfort of residents. The utilization of primitive methods of heating and cooling are necessary due to the lack of electricity in informal settlement areas. An affordable insulation product made from materials that are recycled or readily available can drastically improve the indoor comfort for many residents without the use of electricity. Figure 7 illustrates a study on indoor comfort of 2500 people in regions of South Africa. It

<sup>41</sup> "Namibia Climate," (2009).

<sup>42</sup> "Climate Windhoek - Khomas."

shows that decreasing temperature from 30 to 27 degrees Celsius increases the percentage of subjects comfortable from about 25 to over 90 percent.<sup>43</sup>

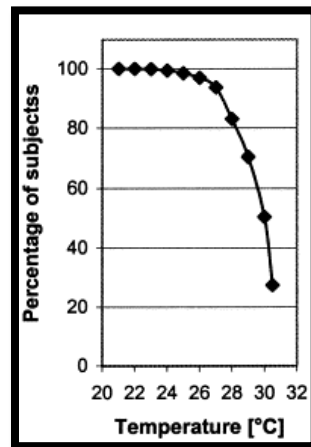

FIGURE 7: PERCENTAGE OF SUBJECTS WHO FELT COMFORTABLE AT A GIVEN INDOOR TEMPERATURE IN SOUTH AFRICA<sup>44</sup>

#### IV. BARRIERS TO LOW-COST INSULATION IN KATUTURA

The key purpose of insulation is to decrease the heat loss from a building over its lifetime such that the energy savings are considerably higher than the original investment.<sup>45</sup> Residents of informal settlements around the world spend up to 20 percent of their disposable income on winter heating.<sup>46</sup> To minimize costs, materials for insulation must consist of primarily natural and reused supplies. Using abundant and easily accessible materials makes insulation more sustainable. Some materials may be more expensive than others, but if the payoff over a period yields a greater profit than the initial cost, insulation would be a beneficial investment for residents. Most insulation used in developed countries is too expensive for use in Katutura and other informal settlements. Such insulation is typically made of expensive polymers, fibers, and plastics.

It is critical that an insulation mixture has a thermal resistivity, or R-value, that is well suited for the conditions of ISAs. The insulation should be able to retain its thermal resistant properties and minimize temperature variation in the shacks when applied to the roofs. R-value is a measurement of

<sup>43</sup> P. B. Taylor et al., "The Effect of Ceiling Insulation on Indoor Comfort," *Building and Environment* 35, no. 4 (2000), 339-346. doi:10.1016/S0360-1323(99)00025-6.

<sup>44</sup> Ibid.

<sup>45</sup> Anders C. Schmidt et al., "A Comparative Life Cycle Assessment of Building Insulation Products made of Stone Wool, Paper Wool and Flax: Part 2: Comparative Assessment," *The International Journal of Life Cycle Assessment* 9, no. 2 (2004), 122-129.

<sup>46</sup> E. H. Mathews et al., "Energy Efficiency of Ultra-Low-Cost Housing," *Building and Environment* 30, no. 3 (1995), 427-432.

insulation's ability to resist heat flow.<sup>47</sup> Accurate R-values take into consideration the settling of the insulate material over its stated life expectancy, which effectively changes the actual R-value.<sup>48</sup> Fortunately, insulation comes in various forms, ranging from blankets, ridged boards, loose fill or spray foam, which allows for flexibility in terms of installation methods.

Though insulating shacks in Namibia may improve living conditions by regulating temperature and reducing energy costs, installing paper insulation in Katutura could easily face local opposition. The community may not see the need to purchase the insulation, find it aesthetically unpleasing, or worry that it will cause more problems than it will solve. Shack insulation could also exacerbate existing problems. The two biggest problems are leaky roofs and recurring fires in informal settlements. Safe implementation of insulation can occur only after addressing these problems.

In Namibia's arid climate, rain is often a welcomed occurrence. However, for shack dwellers of Katutura and other informal settlements, the rain can bring problems. Due to poor construction of shacks, rain can leak through holes in the roofs damaging property inside.<sup>49</sup> Water inside the shacks makes wood fuel unusable, destroys possessions, and in some cases leads to the abandonment of the shack.<sup>50</sup> It is difficult for residents to mend and seal their roofs with the materials available to them. Paper insulation could add to this problem in a number of ways. The rain may quickly destroy the insulation making it an unwise investment. Dampened paper insulation may also serve as a breeding ground for mold and fungi, and reduce indoor air quality, which are known health hazards.

Leaking roofs are only one problem. A more serious problem is the threat of fires. Most shacks lack electricity because some of residences of Katutura are not connected to the electrical grid. Therefore, open flames are commonly used within homes for heat and light. Limited access to fire hydrants adds to the fire hazard and the close proximity of the shacks often leads to rapid spread of fire.<sup>51</sup> These fires cause destruction of homes and a significant amount of burn injuries.<sup>52</sup> It is not uncommon for residents of informal settlements to rebuild or relocate their homes due to fire damage. The flammability of paper insulation can create an additional fire hazard. Controlled open

---

<sup>47</sup> Glen Salas, "Choosing Insulation," *Professional Builder* 69, no. 8 (2004), 57.

<sup>48</sup> "NAMIBIA: Unemployment Up," *Africa Research Bulletin: Economic, Financial and Technical Series* 43, no. 5 (2006), 16966A-16966B. doi:10.1111/j.1467-6346.2006.00265.x.

<sup>49</sup> C. Ihuhua and S. Ikela, "Rain: A Shack Dweller's Worst Nightmare," *Namibian Sun*. December 9, 2011.

<sup>50</sup> Ibid.

<sup>51</sup> Robyn Pharoah, "Fire Risk in Informal Settlements in Cape Town, South Africa," in *Disaster Risk Reduction: Cases from Urban Africa* (London: Earthscan, 2009), 105.

<sup>52</sup> Y. Godwin, DA Hudson and CE Bloch, "Shack Fires: A Consequence of Urban Migration," *Burns* 23, no. 2 (1997), 151-153. doi:10.1016/S0305-4179(96)00118-0.

fires within the shack may also pose concerns. Smoke from the fire contains various harmful toxins, and installing insulation would keep these toxins within the homes.

Fire resistant additives are commonly used in manufactured cellulose insulation to increase resistance to ignition and decrease the rate of flame spreading. Some of the most common fire retardants used in cellulose insulation are boric acid, borax, and ammonium phosphate. Similarly, there are chemical processes of waterproofing paper or cellulose insulation.<sup>53</sup> Complex processes for increasing both fire and water resistances are not feasible for use in shack insulation due to cost and availability of chemical additives. A more feasible solution to the issue of fire safety is encapsulation. Richard Hooker, a retired Fire Protection Engineering Professor at Worcester Polytechnic Institute, proposed this idea to our group. Encapsulation uses materials such as sheet metal to contain the insulation to ensure that open flames cannot reach the paper insulation and ignite.

A study conducted by the University of Pretoria to develop and test low-cost insulation for shacks in South Africa considered the issue of water leakages. The authors of the study weighed the pros and cons of cardboard, glass wool, and rubber as insulation materials and chose rubber granules because of their ability to repel water most effectively.<sup>54</sup> In another study to develop low-cost straw insulation for developing countries, Norford et al used the resin, phenol-formaldehyde, as an adhesive for the straw due to its low-cost and water-repellent nature.<sup>55</sup> Consideration of these methods in Namibia is possible, but availability of rubber and resin may prevent implementation. These studies did not consider methods of improving fire resistance. Both articles mentioned that the insulation needed improvements to fire resistance in future experiments. In order to produce a safe insulation for shacks, preventative measures need to take both water and fire hazards into consideration.

Kambashu construction and design also present barriers to installation of insulation. Most Katutura residents build their own kambashus using materials they find at local hardware stores. These materials include corrugated zinc, sheet metal, wire, nails and wood. Corrugated zinc sheets are available in a standard size, which makes most shacks similar in height, but not necessarily size. Since construction and appearance of a kambashu is dependent on personal taste, development of standard size insulation was difficult. Currently, residents utilize different techniques of weatherproofing walls

---

<sup>53</sup> "Council of Scientific & Industrial Research Files Patent Application for a Process for the Preparation of Water Repellent Chemical Useful for Making Water Proof Cellulose Based Textile Materials," *Indian Patents News* 2011.

<sup>54</sup> Mathews, Weggelaar and van Wyk, *The Development and Testing of Low-Cost Insulation for Shacks*, 307-313.

<sup>55</sup> L. K. Norford et al., "Development of Low-Cost Wheat-Straw Insulation Board," *HVAC&R RESEARCH* 5, no. 3 (1999), 249-263.

such as stuffing holes with plastic bags and pieces of cloth. Few kambashus have insulated roofs, which research shows has the greatest impact on improving the thermal comfort of residents.<sup>56</sup>

## V. GLOBAL CASE STUDIES ON LOW-COST INSULATION

---

Because many cities in Africa and other parts of the world experience the same developmental problems as those faced in Katutura, other researchers have attempted to implement affordable insulation in low-cost housing. They have examined issues such as affordability, fire resistance, water resistance, and public reception. Straw, rubber, cardboard, and cloth are some of the materials evaluated, and each study has its own methodological approaches. Regardless of experimental variation, a common method of determining the ideal solution for insulating houses in ISAs was to test it on the shacks themselves.

A study in Northern Pakistan provides an example of producing low-cost insulation for low-income housing in a different region of the world. An undergraduate student at the Massachusetts Institute of Technology performed this study with the purpose of developing a method to sustainably reconstruct homes destroyed by earthquakes in Pakistan. The researcher examined homes in many different towns and villages to evaluate the best building techniques. She proposed pulping and compressing straw into a board to insulate the homes. Then the straw board was sandwiched between layers of either plastic or reed mats to protect against rain. To install the insulation, the student proposed the use of chicken wire hold the insulation board onto the corrugated iron roof.<sup>57</sup> Although the housing and climate in Pakistan is different from that in Namibia, certain aspects of this method are applicable. For example, the simple installation approach using chicken wire across the roof support beams may be appropriate in Namibia. A weakness of the project is that it does not fully examine the fire hazards caused by the roof insulation.

In 2004, an Interactive Qualifying Project completed in Cape Town by three Worcester Polytechnic Institute students studied improvements to thermal regulation in low-cost housing. The students conducted experiments to determine which low-cost materials were the best insulators and the most practical for use in corrugated iron shacks. A similar study in Pretoria monitored eight low-cost dwellings for two years in order to identify improvements in the comfort of living simply by introducing

---

<sup>56</sup> Mumford, Sulzmann and Tippett, *Energy Efficiency Guidelines for Low-Cost Housing*.

<sup>57</sup> Zehra Ali, *Sustainable Structures for Post Disaster Reconstruction: An Integrated Approach for Reconstruction after the South Asia Earthquake*, Massachusetts Institute of Technology, 2007.

insulation. While the Cape Town study used various improvements including ventilation, solar orientation, shading, reflective exterior surfaces, and insulation, the Pretoria study analyzed temperature variation in the shacks over a year, with and without insulation. Both studies applied the insulation in varying thicknesses. The Cape Town group showed that the improvements, on average, made the shacks about four and six-tenths degrees Celsius cooler in the day and two degrees warmer at night.<sup>58</sup> In Pretoria, for the six homes which insulation was applied to, the improvement in temperature difference between indoors and outdoors was between two and four and a half degrees Celsius. The improved temperature within shacks resulted in an average improvement in indoor thermal comfort of nearly thirty percent.<sup>59</sup>

Both of these case studies concluded that there were improvements in thermal regulation after installing insulation in low-cost homes in South Africa. Climate and housing in South Africa is similar to that in Namibia. Therefore, these studies indicate the potential results of insulating shacks in Namibia. Orientation and installation techniques of the Cape Town study were taken into account to optimize low-cost insulation. However, the materials used in these experiments were not available to us at the Men on the Side of the Road organization. We conducted further research on the thermal effects of paper insulation to determine if this project will successfully improve thermal comfort in kambashus.

Due to high unemployment and poverty rates in Namibia as well as a lack of low-income housing in urban areas, informal settlements are growing. The lack of resources and poor construction of shacks attribute to the poor living conditions in these settlements. Low-cost insulation for corrugated zinc shacks could be beneficial to the residents of informal settlements by reducing the extreme temperature fluctuations experienced between the summer and winter months as well as between night and day. Applying insulation to homes addresses the need for both temperature control and improved living conditions in kambashus of ISAs in Namibia. The Paper Insulation Project also addresses the staggering unemployment rate in Namibia by providing MSR with another project, which will employ and train its members.

---

<sup>58</sup> Mumford, Sulzmann and Tippet, *Energy Efficiency Guidelines for Low-Cost Housing*.

<sup>59</sup> Taylor et al., *The Effect of Ceiling Insulation on Indoor Comfort*, 339-346.

## CHAPTER 3: METHODOLOGY

---

The Men on the Side of the Road organization requested a study on the feasibility of using recycled paper as an insulation material for kambashus in Katutura. The goal of this project was to work collaboratively with Katutura residents to investigate feasible methods of developing community-based paper insulation for kambashus. We developed, with input of the community, an insulation product that Katutura residents will both produce and use. We developed the following objectives in order to achieve our goal:

- I. Determine how Katutura residents currently construct and insulate their kambashus and if the cultural background of residents and the regional environment affect kambashu design
- II. Determine the availability of resources, effectiveness of insulation in kambashus, and feasible production methods to assess the potential of producing paper insulation
- III. Interpret test results to determine the most appropriate insulation mixture in terms of thermal properties, fire and water resistance, ease of production, cost, and community preference
- IV. Observe and analyze the production and marketing of MSR's Paper Block Project to apply similar techniques to develop the Paper Insulation Project

This chapter will explain the methods we used to gather information to address each objective.

### OBJECTIVE I.

---

**Determine how Katutura residents currently construct and insulate their kambashus and if the cultural background of residents and the regional environment affect kambashu design**

---

### KAMBASHU OBSERVATIONS IN KATUTURA

---

Our group visited homes in four different regions of Katutura, Freedomland, Havana, Hakahana, and One Nation, to better understand how residents in the informal settlements of Katutura construct kambashus and cope with acute temperatures. We observed and documented techniques to design and build kambashus and spoke with community members to understand their perspectives of the project. Receiving feedback from the community was valuable as it provided insight on various aspects that experiments could not compensate for.

We visited One Nation to speak with an MSR member, Aser, at his kambashu. We spoke to him about his kambashu, shown below, to gather preliminary information about shacks. More pictures can be found in Appendix E.



FIGURE 8: ASER'S KAMBASHU IN ONE NATION, KATUTURA<sup>60</sup>

In One Nation, we observed several methods of sealing holes, attaching walls and roofs, and other structural differences. To better understand observations pertaining to why the kambashu is built the way that it is and the cost feasibility of improvements made, we asked several questions of residents. The questions we asked included:

- Where do you see leaks in your roof and how have you stopped them?
- How do you fill the gaps in the walls and roof? Why?
- Where do you get electricity? Do many homes in this area have electricity?

A complete set of interview questions can be found in Appendix B.

In Hakahana, we spoke with Pius and his family at a new kambashu that he is building. At Pius' home, pictured in Figure 9, we were able to make several more observations about the size and quantity of gaps in kambashus. We asked him and his family questions pertaining to thermal comfort such as:

- What methods do you use to cool your home during the day?
- How do you decorate your home and how would you like the insulation to look?

---

<sup>60</sup> Photograph by Emily Fournier March 2012.





FIGURE 9: PIUS' KAMBASHU IN HAKAHANA, KATUTURA<sup>61</sup>

We were able to ask Pius and his family more specific questions because of his understanding of the goals of our project and why we were observing these building techniques.

---

### COMMUNITY INTERVIEWS

---

We asked community members questions when we travelled into Katutura to identify different barriers to developing an effective insulation including weather, climate, and culture. It was important to ask locals from various backgrounds these questions in order to obtain a broader opinion of current conditions. The visit to Katutura helped us understand the techniques and practices for cooling, heating, and improving kambashus. Understanding how kambashus are made, and why improvements are done on them was beneficial background for the next steps in our project.

We also looked into cultural and environmental factors to further our understanding of kambashus in Katutura. Pius, who is from Katutura, and Magdalena, who is from a small village in the north, answered the questions below.

- How often are there shack fires each year?
- How often are there large storms or rain?
- Is flooding a problem in Katutura?
- Do the different ethnical groups in Katutura build their kambashus differently?
- Are there ways in which your family makes homes in your village to keep it cooler or warmer? (If yes), are these methods applied to kambashus?

---

<sup>61</sup> Photograph by Emily Fournier March 2012.

In Havana, we conducted six in-depth interviews with community members. We also conducted eight additional interviews in Freedom Land, which is located behind the MSR office. We carried out some interviews on the market sidewalk after we sold paper blocks and others within the kambashus of residents who had invited us into their homes. We completed these interviews to assess current conditions and gauge the need for insulation. Interview questions included:

- How hot is it inside your shack during the day? How about at night?
- How much money do you spend to heat or cool your home each year? For wood, kerosene, or electricity?
- Would you purchase a low-cost insulation? (If yes) How much would you spend on it?

We also asked questions concerning fire safety and leaks in roofs to further understand the barriers to developing an insulation material. A complete set of interview questions can be found in Appendix B. Pius and Magdalena clarified our questions in Oshiwambo whenever necessary since most community members interviewed spoke some English, but their native tongue is Oshiwambo. Translating explanations of what insulation is as well as how and why it is used took some time and was difficult for some community members to understand. For that reason, we found it difficult to conduct several interviews. Taking the time to conduct these interviews, however, was beneficial for us to understand the need for insulation and the obstacles that we faced in developing the project.

---

## COMMUNITY DISCUSSIONS

---

After developing a working prototype of insulation, we conducted discussions and demonstrations with MSR members to show them the use of insulation and its effects. We discussed their current practices in heating and cooling their shack as well as their willingness to purchase the insulation. Appendix K details the questions asked of community members and MSR members to gather this information.

Input from community members was valuable because they are knowledgeable about the available resources and cost effective solutions to problems they face. Through these discussions, we were able to identify if there is a need and desire for the insulation product we are developing. The goal of the Paper Insulation Project is to create jobs through sustainable efforts. We assessed whether or not the community members would purchase insulation in order to determine if development of this project

will create jobs. There is also potential to produce insulation for other markets; however, the MSR organization prefers that it remain a local endeavor.

## OBJECTIVE II.

---

**Determine the availability of resources, effectiveness of insulation in kambashus, and feasible production methods to assess the potential of producing paper insulation**

---

### BUILDING SMALL SCALE KAMBASHUS

---

During our visits to Katutura, we recorded observations on the most common materials and structures used in shack design. We used this information to construct two small-scale kambashus to test the sample insulation. Our group purchased materials that were relatively cheap and similar to those used by the community. Thus, our kambashus are comparable to full scale ones, even though we did not build them to scale. We built wooden frames, shown below, with dimensions of 30 centimeters by 40 centimeters to fit three insulation blocks. In order to create a slightly sloped roof similar to those observed in the community, we incorporated a difference in height making one side 30 centimeters tall and the other 32 centimeters tall. We fastened the wooden frame using large screws.



FIGURE 10: WOODEN KAMBASHU FRAME<sup>62</sup>

We attached the corrugated zinc pieces with bottle caps and nails. The completed small-scale kambashus are pictured below.

---

<sup>62</sup> Photograph by Marco Villar March 2012.



FIGURE 11: COMPLETED SMALL-SCALE KAMBASHUS<sup>63</sup>

---

### PAPER BLOCK AND INSULATION PRODUCTION

---

To determine how we could implement low-cost methods in insulation production, we participated in the production of the paper blocks. Pius, the coordinator of the Paper Block Project, taught us that he makes the blocks by mixing shredded office paper, woodchips, and water in a large drum. He then adds water until the mixture is saturated just below the surface. Pius used informal measurements (i.e. bag or bucket) rather than formal measurements such as weight or volume because they require less time and equipment. The mixture soaks in the water for three days and is mixed regularly. After soaking, he scoops the mixture into a mold and presses it until most of the water is forced out. Finally, the wet blocks are set out in the sun to dry for about a week. A complete picture description of this procedure can be found in Appendix D.

To make prototypes of insulation mixtures we used materials from the Paper Block Project to develop a cost effective product. For example, rather than constructing an expensive mold just for the small-scale insulation, we adjusted the use of the mold from the Paper Block Project. To modify its use, we drew a line on the inside to indicate the appropriate level to fill the pulp mixture up to for the desired thickness. We then inserted a slab of wood to fill the remainder of the mold before pressing out the excess liquid. The mold is pictured below in Figure 12.

---

<sup>63</sup> Photographs by Emily Fournier and Marco Villar March 2012.

FIGURE 12: PAPER BLOCK MOLD<sup>64</sup>

We also incorporated recycled waste materials into the test insulation. The available waste materials include shredded office paper, shredded newspaper, and sawdust. We varied the composition of the paper blocks by making mixtures with 50 percent more paper and 50 percent less paper than the standard paper block mixture. We also made the standard mixture and a mixture with newspaper at the standard ratio. We counted the days for drying as the number of days that the blocks were uncovered and left open to the wind and sun.

---

### TESTING THERMAL PROPERTIES OF INSULATION MIXTURES

---

In order to test the thermal resistance of the insulation, we tested each insulation mixture in a model kambashu against a control containing no insulation. We attached chicken wire with nails to the wooden frame under the roof of the models as shown above in Figure 11. For each type of insulation, we loaded three blocks under the roof by placing them on top of the chicken wire. We trimmed some of the blocks slightly to fit. The models had hinged roofs for ease of access to the insulation. The thermometers used in this experiment were dry bulb, mercury thermometers with a range of -20 to 100 degrees Celsius (-4 to 212 degrees Fahrenheit). We suspended the thermometers in gaps in the kambashu walls as pictured in Figure 13.

The thickness of each insulation block was approximately 3.5 centimeters. We conducted preliminary tests to determine the optimal testing conditions such as start time, length and frequency of

---

<sup>64</sup> Photograph by Janet Wicks January 2012.

data collection, and optimal testing location. For each type of insulation, we recorded temperatures at 60-minute intervals for the outside temperature, control, and insulated model over 24 hours. We decided that a 24-hour test would depict the full range of daily temperature fluctuations that we wanted to observe. Temperature collections began at 14:00 and continued until 13:00 the next day. We chose this time range because we could observe the effects of the insulation going into the night, retaining heat through the night, and then its ability to resist heating up again in the morning. We tested each type of insulation against the control on days similar in temperature range. The testing set-up is pictured below.



FIGURE 13: EXPERIMENTAL SET-UP FOR THERMAL PROPERTIES TESTING<sup>65</sup>

The purpose of this test was to determine how effective the insulation mixtures are in regulating indoor temperatures and increasing thermal comfort.

---

### TESTING INSULATION THICKNESS

---

We performed thermal property testing on insulation sheets of two thicknesses to determine how the thickness of the insulation affects its ability to regulate temperature. We determined the most effective insulator from the thermal property testing explained above. Then we tested that mixture at

---

<sup>65</sup> Photograph by Emily Fournier March 2012.



an increased thickness of 5 centimeters. Using the same experimental process, we compared the thin insulation against the thick insulation on the same day to determine which one is a more effective insulator. We also compared the two thicknesses in terms of community preference. During our community discussions and presentation of the prototypes, we asked members of MSR which size they thought would look better in the kambashus and which size they thought would be the most effective insulator.

---

### TESTING INSULATION FLAMMABILITY

---

We determined the flammability through two measurements: ignition rate and spread rate. To test the flammability of the insulation blocks, we first tried the tests with matches or pocket lighters. We discovered that these flames were not strong enough to adequately test the blocks for flammability, so we exposed the blocks to both an open fire and the direct flame from a welding torch. The strong flame of the welding torch allowed us to test ignition and spread rate at higher temperatures. We tested one 3.5 centimeters thick sample for each insulation mixture.

We defined ignition rate as the time needed for the sample to catch fire. We determined the ignition rate of our samples by lighting each sample with the welding torch and measuring the time from when the flame touches the sample to when the material catches fire. At higher temperatures, we simply recorded whether the block caught fire after ten seconds.

We measured spread rate as what fraction of the block was smoldered after ten minutes. We determined the spread rate by exposing the block to the welding torch for one minute. Then, the block was set aside for an additional ten minutes. After ten minutes, we recorded final observations.

We conducted additional testing to see how long each insulation mixture sustained a flame without direct exposure to a fire. After holding the welding torch to the insulation for forty seconds, we recorded how long the block stayed lit. After removing the torch, we noted and recorded observations such as the amount of smoke and soot produced by the block.

An interviewee recommended that we add salt to one soaking mixture to reduce the flammability of the 50 percent less paper sample. We produced additional salt samples to observe the effects of a salt additive as a fire retardant.

### OBJECTIVE III.

---

#### **Interpret test results to determine the most appropriate insulation mixture in terms of thermal properties, fire and water resistance, ease of production, cost, and community preference**

The key criteria in determining the most effective insulation were thermal resistivity, cost, ease of production, water and fire resistance, and community preference. We determined thermal resistivity by the procedure described in the section titled *Testing Thermal Properties of Insulation Mixtures*. We ranked each mixture against the others with a five representing the greatest average temperature change and a one representing the least when compared to the control of that experiment. We determined cost by the availability of resources and estimated cost of production per sheet. Mixtures of paper and wood chips or newspaper and wood chips are free because the waste materials are provided to MSR without charge. The scale for cost ranked from one to five, five representing no cost. Ease of production was determined by the combination of the number of days required for soaking, number of days required for drying, and the ease of turning the mixture. We scored the sub-categories on a scale from one to five, five being the shortest time, or the easiest to stir. The total score was then divided by three to determine the total score for ease of production. Water resistant insulation was another technique for weatherproofing but we did not make a waterproof insulation material. Fire resistivity was determined by the ignition time and spread rate described in the section titled *Testing Insulation Flammability*. We gave a score ranking the samples against one another in each category, with five representing the longest ignition time, shortest time to extinguish the flame, and least smoke danger. This total score was divided by three to represent the fire resistivity of the mixture. Finally, we determined community preference by discussions with MSR members. We asked them to rank the appearance, preference of thickness, and opinion of the overall best insulator. These questions were opinion-based and only used to determine a general community preference to the chosen insulation. We understand that responses will vary based on personal preferences and that the data collected is not as scientifically sound as the other ranked categories.

The insulation mixture chosen was determined based on this system. The ranked data sheets can be found in Appendix I.



## OBJECTIVE IV.

---

### **Observe and analyze the production and marketing of MSR's Paper Block Project to apply similar techniques to develop the Paper Insulation Project**

The Men on the Side of the Road Project will train members to produce and sell the insulation. In order to make recommendations on training methods for producing and marketing the insulation, we observed and analyzed the Paper Block Project. In our visits to communities in Katutura with Magdalena and Pius, we brought along four boxes of paper bricks to sell to observe how Pius sold the bricks and talked to the community about their use. We were also able to see how the community reacted to the product and what their concerns in purchasing the bricks were. These observations were beneficial in understanding the obstacles that we may encounter in the insulation project. When selling the blocks, Pius handed out small informational pamphlets in both English and Oshiwambo that explained the use of the blocks and the purpose of the MSR organization. We developed a similar handout, attached in Appendix J, which explains the use and purpose of insulation, installation information, and the purpose of MSR. We gave a presentation to MSR members at the community meetings on 18 April 2012 and 01 May 2012. We used these presentations to recommend marketing strategies that MSR members can use to sell the produced insulation.

We derived the methods for making sample insulation sheets directly from the Paper Block Project with the only difference being that the samples are approximately 3.5 centimeters thick while the blocks are 5 centimeters thick. A press, with a similar mechanism to the one used for blocks, was designed for the production of insulation sheets. Due to the lack of our technical expertise in welding, our group consulted with a welding company in order to produce a prototype.

## CHAPTER 4: RESULTS AND DISCUSSION

---

Through various methods of observation and experimentation, we identified the criteria necessary for developing a sustainable and cost effective paper insulation material. This chapter focuses on the findings and the problems that arose in developing an optimal paper insulation mixture. We also analyzed and reviewed the feedback received from potential users of this product and current users of the paper blocks. This chapter is divided into five parts: I. Analysis of the Need for Insulation, II. Kambashu Construction, III. Materials and Production of Insulation, IV. Comparison of Insulation Mixtures, and V. Marketing Techniques.

### I. ANALYSIS OF THE NEED FOR INSULATION

---

**Our research and feedback from the community showed that indoor temperatures are uncomfortable for residents, thus thermal regulation techniques, such as insulation, are necessary for kambashus in Katutura.**

After conducting fifteen interviews, we discovered that almost all residents agreed that temperatures inside shacks are uncomfortable. Almost every person interviewed explained that daytime temperatures during the summer made internal kambashu temperatures unbearable. Additionally, community members confirmed that the temperature inside their shacks got hotter than the outdoor temperature during the day. One resident of Havana exclaimed that they are “suffering from the heat” during the day and temperatures at night and in the winter are uncomfortably cold. We personally experienced this phenomenon when visiting Aser and Pius’ homes. More than half of the interviewees stated that it was too cold in their homes during the winter months. Surprisingly, many people did not find the cold temperatures at night, in summer months, to be a problem. Individuals stated that nighttime temperatures were not normally a concern because they often embraced the cooler air as a relief from the staggering daytime heat.

The interviewees informed our group of the ways they deal with the extreme indoor temperatures. None of the people we interviewed said that they already used insulation in their kambashu. Everyone who we asked to describe how they handle the heat stated that they simply left the door open or stayed outside their kambashu during the summer. One person also said that they used a fan during the summer to provide some relief from the heat, but most interviewees did not have electricity for the use of such appliances. In some shacks, residents decorated the interior with cloth sheets to alleviate some of the heat conducted by the corrugated metal roof. We also discovered that

planting small trees or bushes around the shacks was popular. This provided some shade on the outer walls as well as privacy and decoration. Paint is a more expensive, but effective regulator of temperature used by a small number of people in the communities we visited. White paint applied to the outer walls and roof of the shack reflects heat and prevents conduction into the shack. In the winter, most people used blankets and jackets to keep warm because they did not have access to electricity or could not afford it.

When we introduced the idea of insulation during the interviews, most people were not familiar with the word, but understood the concept. We later found that there is no Oshiwambo word for insulation, which increased difficulty in communication. The residents agreed it would solve the current problem of extreme heat in kambashus. People were interested in purchasing such insulation after consideration of a few constraints such as cost and safety. In order for people to afford insulation, it must be very cheap. If the price of insulation sheets were comparable to those of the paper blocks (N\$1 per block), then most people found the price to be acceptable. When interviewing three females they suggested charging N\$2 per sheet of insulation. When we surveyed fourteen MSR members during a community meeting on 18 April 2012, they responded that they would pay between two and five Namibian dollars for a sheet. In a second community meeting on 01 May 2012, seventeen MSR members came to the consensus that a reasonable price would be N\$2.50 per sheet.

Another constraint that we considered for the paper insulation was fire safety. Interviewees confirmed that shack fires were prevalent in the settlements. Residents confirmed that usually, careless use of candles was the reason for shack fires. They explained that candles are forgotten about or knocked over by children or drunken adults. The knocked over candle then causes thin cloth sheets to catch fire, which allows the fire to spread quickly. The majority of those interviewed were not concerned if the insulation could catch fire. This is because they thought that as long as users take precautions towards fire safety, there should not be a problem. They also said that because the fires start on the ground, they were not concerned with insulation on the roof increasing the incidences of fires. Some individuals were still concerned about this added fire hazard. A male of approximately 30 years of age was concerned because the fire brigade was very slow when responding anywhere in Katutura. The lack of street names and addresses in informal settlements makes the problem even worse. This justified our plan to investigate methods of reducing the flammability of the paper insulation.

## II. KAMBASHU DESIGN AND MAINTENANCE TECHNIQUES

---

We found that the structural design and maintenance of kambashus affects the application of insulation. Through observations and informal discussions with residents of Katutura, we focused on learning how culture and environment affect shack design and the problems addressed when building or mending a kambashu. This section analyzes the different shack modifications that individuals use to overcome the severity of the Namibian climate and how these modifications relate to the application of insulation in shacks.

### **Knowledge, personal preference, and income affect kambashu design and improvements.**

By comparing observations of multiple houses, we concluded that Katutura residents build their kambashus using the same materials and a similar structure. The outside appearance of kambashus in One Nation and Hakahana did not appear considerably different, as shown in Figure 14. We found that some kambashus had sloped roofs while others did not. We also noticed different methods of joining the kambashu walls at the corners and roof. These different structural techniques varied based on the knowledge of the primary builder of the kambashu. Internal modifications and varying shack maintenance techniques were the more distinguishing factors of kambashus. For example, some residents added small, approximately 0.09 square meters, solar panels to provide energy for small electronics such as music players. Aser stated that the energy from the solar panels did not provide enough electricity to power larger items. We found that some wires from these devices might need rewiring so that residents can properly apply insulation the roof.

According to Aser, community members complete improvements to their kambashu within two years of original construction. For many residents, these improvements are only feasible when they can obtain the necessary funds. On a scale of priority, kambashu modifications rank relatively low. Necessities such as food, water, school supplies, and any other provisions required for everyday living are more important to residents. He explained that most people considered improvements to living quarters essential after satisfying these necessities.



FIGURE 14: ONE NATION KAMBASHUS VS. HAKAHANA KAMBASHUS<sup>66</sup>

**Cultural background does not affect kambashu design in Katutura.**

We found that an individual may have decided to make modifications to his own shack in a different manner than others, but we did not observe any building techniques that were specific to a certain culture. When ISAs first developed, residents were broken into sections based on tribal backgrounds. Each tribe was designated a letter that was painted on the outside of their shack. When apartheid ended, newcomers to the informal communities could settle wherever they pleased. We found that the only distinguishing factors between the many different tribes that live within these areas were the letter-number combination painted on the side of some shacks. Our group determined that because cultural background does not affect the kambashu design, we did not have to develop an insulation designed to fit different cultural needs. This allowed us to produce one insulation design for the Paper Insulation Project.

**Most residents already apply foam-forming glue, weatherproofing membranes and other waterproofing methods to weatherproof their kambashu.**

Almost all of the kambashus we observed, either had no problems with leakages, or applied techniques for weatherproofing, such as foam-forming glue, waterproofing membranes, and bottle cap washers. Almost every kambashu we walked past used bottle caps as cheap alternatives to washers in order to provide a seal and prevent rain from leaking through small openings. Kambashus with a sloped roof did not have a significant problem with leaks since water tended to flow into the corrugations, down the slope, and off the roof. Another noticeable exterior detail was the use of a waterproofing paint and membrane along seams and openings in the corrugated zinc. To use the weatherproofing

---

<sup>66</sup> Photograph by Emily Fournier March 2012.

membrane, residents apply a layer of the waterproofing paint, cover it with the membrane, or cloth gauze, and apply another layer of the paint. These materials provided a watertight shack, shown in the center picture below. A foam forming glue was another material used to seal gaps in an effort to prevent water leakage as well as wind flow through the shack. Many residents also used cloths and plastic bags to fill openings in the exterior walls of their shacks. All of these materials help minimize wind flow and water leakage in Kambashus due to rain and storms.

Interviews with Katutura residents showed varied responses on the degree to which leaks are a problem and the methods used for mending leaks in shack roofs. Certain kambashus had more problems with water leakages than others did, but it was apparent that most had several improvements to stop leaks. This was especially true for residential kambashus, but not necessarily true for those utilized for businesses. For example, one salon owner told us that she did not make any effort to seal large gaps in her salon. Instead, she moved items in the salon to one side or other when it rained depending on where the water was coming in. One resident simply placed buckets under the source of the leak to collect water. This method of dealing with water leakages poses a large threat to our paper insulation because water has the tendency to break the insulation apart, which increases its susceptibility to fire and decreases its insulating properties.



FIGURE 15: MULTIPLE WATERPROOFING TECHNIQUES<sup>67</sup>

**Weatherproofing is necessary for kambashu roofs prior to installing insulation to ensure water does not increase susceptibility to fire and decrease insulating properties of the insulation.**

The production of miniature kambashus allowed us to understand construction techniques as well as the fiscal requirements of building and weatherproofing a shack. Table 1 depicts the cost of all materials purchased and used in the production of two miniature kambashus. Important costs to note

---

<sup>67</sup> Photograph by Emily Fournier March 2012.

are the cost of the waterproofing paint and fabric and foam forming glue. Waterproofing of kambashus is a necessary improvement before installing insulation so that the insulation does not break apart or mold. Foam forming glue costs approximately N\$60 (about US\$9) for a small tube, which may be expensive for some residents. A more realistic investment for some residents may be waterproofing paint and fabric, at N\$40 or about US\$6. Improvements such as bottle cap washers, cloth and plastic, and rocks or other heavy items produce a tighter seal are all free of cost. These techniques do not provide a seal that is completely waterproof like the glue and membrane do. For that reason, we found that most residents would need to make an initial monetary investment to waterproof their kambashu before investing in insulation. This will eliminate health and safety problems that may arise if water damages the insulation as well as increase the lifetime of the insulating material.

TABLE 1: MATERIAL COSTS FOR KAMBASHU SUPPLIES FROM BUILD IT (2012)<sup>68</sup>

Material	Cost
Corrugated Zinc Sheet 0.3mm x 2400mm x 8 ft	N\$ 62.57
Timber 38mm x 50mm x 4.2m	N\$ 36.97
Drywall Screws 4.2 x 75mm (50 pieces)	N\$ 26.91
Screws 4.1 x 25mm (100 pieces)	N\$ 18.22
Panel Pins 32mm 250g	N\$ 18.51
Hinge (50mm)	N\$ 12.13/each
Waterproofing Fabric (100mm x 10m)	N\$ 11.95
Waterproofing Paint (1 L)	N\$ 27.78
Foam Forming Glue (small 20 oz tube)	N\$ 60
Chicken Wire (1 square meter)	N\$ 21/meter
Bottle caps, cloth, plastic bags	Free

**Most residents do not utilize ventilation techniques in their kambashus because they would rather protect their home from the damaging effects of wind and rain.**

We found that the environmental factors greatly influence the implementation of ventilation in shacks. Due to the lack of electricity in most informal settlements, most families cook meals using

---

<sup>68</sup> April 2012 exchange rate is N\$ 7.76 per US\$ 1.

firewood, kerosene, or paraffin stoves. Through interviews, our group learned that people who wished to cook indoors incorporated ventilation into their home. In our multiple visits to the informal communities, we did not notice any instances where residents utilized indoor ventilation. We then concluded that most people living in these informal settlements chose to cook outdoors. We confirmed this conclusion through the interviews we conducted. Our group found that most ISA residents wanted to make their shacks as airtight as possible to ensure that wind and rain could not flow into the shack. We found that the lack of ventilation techniques is beneficial for applying insulation in a waterproof shack.

### III. MATERIALS AND PRODUCTION OF INSULATION

---

We found that we must develop an affordable insulation sheet that is stable and made to optimize its insulating properties. This section analyzes the materials used in the insulation sheets to provide a sustainable and affordable product. We also analyze the mold design, which minimizes thermal gaps and aids the installation process.

**We confirmed that the materials used for the Paper Block Project are effective insulating materials and are cheap and sustainable resources.**

MSR used recycled paper and waste sawdust for the paper blocks because those supplies are readily available and free. The Windhoek Vocational Training Centre donated the waste sawdust and Envirochance donated the shredded office paper. The recycled waste materials used for insulation ensured an affordable product because they are cheap and readily available. MSR employees and our project sponsor, Janet Wicks, informed us that the use of waste materials in production of the insulation is crucial, which is why traditional insulation materials were not utilized.

For testing purposes, we modified the paper block press to produce sample insulation sheets. We eliminated a financial burden for MSR in the research stages of this project by using the paper block molds. We developed an insulation mold, described in a section below, after we determined that the paper and woodchip material was an effective insulator.

**We found that installing insulation would be more cost effective than applying heat reflective paint to the roof of kambashus.**

We determined that a standard size kambashu has a roof of about three meters by six meters by averaging the different size houses we observed. According to the online Neopaint calculator, a roof of that size would require about six liters of paint. The Neo Heat Reflective paint is sold in five liter and



twenty liter buckets at N\$336.99 and N\$1275.35 respectively, and the paint lasts for five to seven years. From our calculations, the 18 square meter roof would require 247 sheets of insulation. In order to create an insulation product that is affordable to Katutura residents it will need to be competitive with the heat reflective paint. Table 2 shows that the cost of heat reflective paint is between the high and low estimate of the cost of insulating the same size kambashu. We have not established longevity of the paper insulation yet. For that reason, we assumed that the paper insulation has the potential to be competitive based on the overall cost of the paint in comparison to insulation. By selling the insulation sheets for one Namibian dollar each, the paper insulation is very affordable and much cheaper than heat reflective paint. We found that paper insulation is a sustainable and cost effective solution to thermal regulation in kambashus.

TABLE 2: COST ANALYSIS OF HEAT REFLECTIVE PAINT COMPARED TO PAPER INSULATION<sup>69</sup>

Material	Material Cost	Roof Size	Cost for Roof Coverage
<b>Neo Heat Reflective Paint</b>	N\$ 336.99/5L Bucket	18 sq meters	N\$ 673.98
<b>MSR Paper Insulation High Estimate</b>	N\$ 5/ 0.085 sq meter sheet	18 sq meters	N\$ 1,059
<b>MSR Paper Insulation Low Estimate</b>	N\$1/ 0.85 sq meter sheet	18 sq meters	N\$ 247

**In order to produce the most efficient product we created a new mold to reduce the thermal gaps between the sheets of insulation.**

We determined that the rectangular shape of our insulation created thermal gaps between sheets, so we designed a new mold to create a shape that increased the efficiency of the insulation. The new shape, depicted below, eliminates the number of vertical gaps so that air circulating within kambashus has difficulty escaping. Interconnecting the sheets of insulation on all four sides eliminates the thermal gaps. The lengths slide into each other because of indentations along the entire surface. The widths of the insulation are sloped, allowing each sheet to sit on top the next without affecting the overall thickness of the insulation. During the day, this provides a larger surface area resisting thermal change caused by increasing temperatures. Research suggests that at night, the new shape would trap the warm air inside the kambashus more easily. The new mold and block designs are pictured below in Figure 16.

---

<sup>69</sup> Quoted by Fritz Rantsch, Technical Advisor for Neo Paints Factory.



FIGURE 16: PROTOTYPE INSULATION MOLD AND SHEETS<sup>70</sup>

After consulting with Christo from the Central Metal Works (CMW), we determined that the proposed design was the most simplistic out of the ones considered. This mold uses a vertical compressive motion like the paper block mold. Additionally, the shape allows the mold to retain its shape after being subject to compressive forces, without reinforcing material. Most importantly, one can remove the sheets of insulation easily from the mold. We designed the mold to create sheets of insulation 21 by 37 centimeters. We chose this size after asking people from Katutura how big they would like the sheets to be and considering any stability compromises. Members installing the insulation sheets can easily transport sheets of this size and they fit through narrow doorways. The new size and shape of the insulation may negatively affect the insulation's performance and stability on a larger scale, but our research and consultation has shown that this is unlikely. Detailed images of the paper insulation mold can be found in Appendices M and N.

#### IV. COMPARISON OF INSULATION MIXTURES

---

Through testing, observations, and informal discussions, we thoroughly investigated the best insulation material. This section analyzes the categories considered for choosing the best insulation: thermal properties, flammability, susceptibility to water, ease of production, cost, and community preference.

---

<sup>70</sup> Photograph by Marco Villar May 2012.

**The paper insulation mixture with a ratio of 50 percent less paper and the same amount of wood chips as the standard mixture was the most effective at regulating kambashu temperatures.**

To simplify thermal resistivity calculations, we compared the thermal properties of the insulation mixtures by calculating the difference in temperature between the control and the insulated models instead of calculating R-values. According to Janet Wicks, R-values would not provide meaning to most Namibians, and therefore would not offer any informational asset to our project. Out of the four different insulation mixtures tested, the 50 percent less paper insulation reduced internal shack temperatures the most during the daytime. The daytime effectiveness of each insulation mixture was determined by taking the average difference in temperature between the control kambashu without insulation and the insulated Kambashu from the hours of 10:00 to 13:00. We chose these times because they are the most consistent daytime readings for all experiments. Table 3 shows the compiled average temperature difference for each of the tests we performed. We found that the 50 percent less paper insulation mixture was the best because it was an average of 3.75 degrees Celsius cooler than the control shack. The temperature difference ranged from two to seven degrees cooler in the insulated shack. Figure 17 shows a graph of the temperature inside the model kambashu with 50 percent less paper insulation compared to the control and outside temperature.

TABLE 3: SUMMARY OF AVERAGE TEMPERATURE DIFFERENCE BETWEEN THE INSULATED SHACK AND THE CONTROL

<b>Paper Mixture</b>	<b>Degrees (C°) Cooler than Control Daytime: (10:00 - 13:00)</b>	<b>Degrees (C°) Hotter than Control Nighttime: (18:00 - 10:00)</b>
Standard	3.125	1.5
50 Percent Less Paper (test 2)	3.75	1.4375
50 Percent More Paper	1.5	1.5
Standard Newspaper	1.5	1.1875
50 Percent Less Paper Thick (5cm) vs. Thin (3cm)	1.25	0.6667

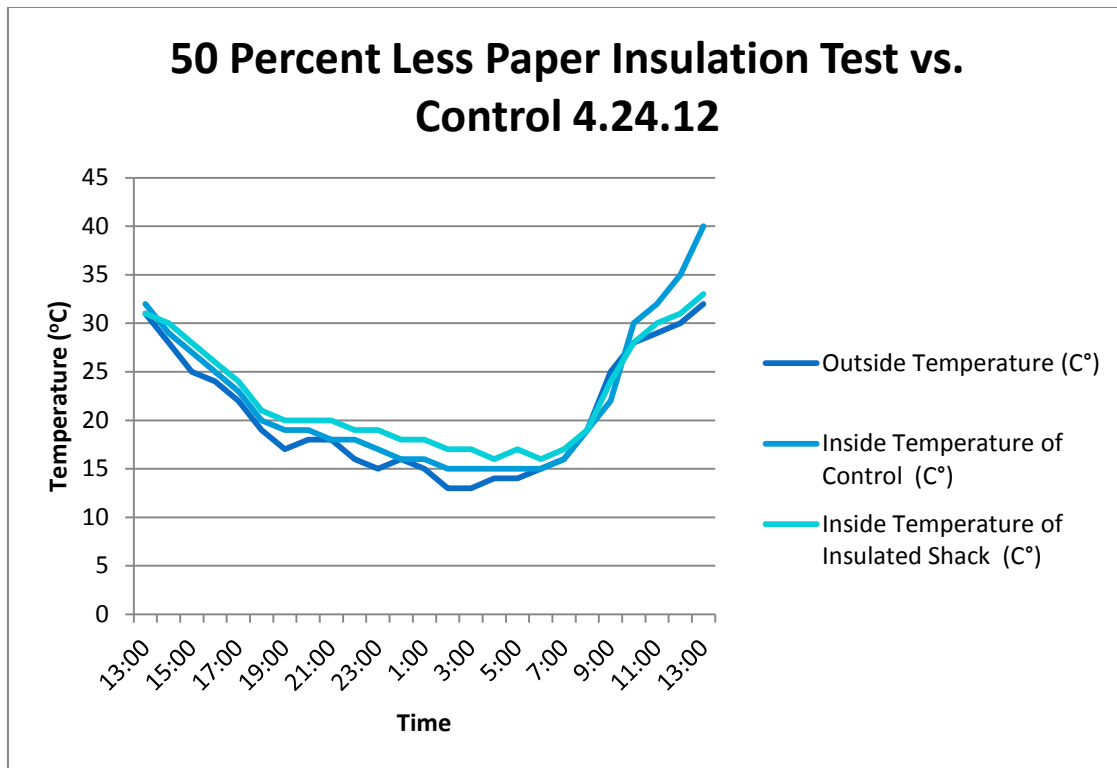

FIGURE 17: THERMAL TEST RESULTS FOR 50 PERCENT LESS PAPER INSULATION

The newspaper and 50 percent more paper mixtures were the least effective at regulating internal temperature with only a 1.5 degrees Celsius difference between the insulated shack and the control. All insulation mixtures were effective in regulating temperature in the model kambashus throughout the night. All insulated models remained one to two degrees warmer than the control at night between the hours of 18:00 to 10:00 when the temperature outside dropped. Figure 17 also shows the comparison of temperatures inside the model shack with 50 percent less paper insulation compared to the control and outdoor temperature at night. During this test, the temperature inside the insulated shack remained about two degrees warmer than the control during the night. Appendix G contains all of the data and graphs for these experiments.

**The thickness of the insulating material does not greatly affect its insulating properties.**

After testing the five-centimeter thick insulation against the three-centimeter thick insulation, we found that the thicker material was not more effective at insulating the test kambashus. The graph below shows that the thin insulation was, at most, two degrees warmer or cooler than the thick insulation. We also found that thicker insulation would be more difficult to suspend from the roof because it is significantly heavier. In a community meeting with 17 MSR members, everyone agreed

that they would prefer the thinner insulation due to its lighter weight. Members were concerned that the thick insulation would cause the chicken wire to sag, requiring additional support. For those reasons, we determined that a thinner insulation sheet is more appropriate.

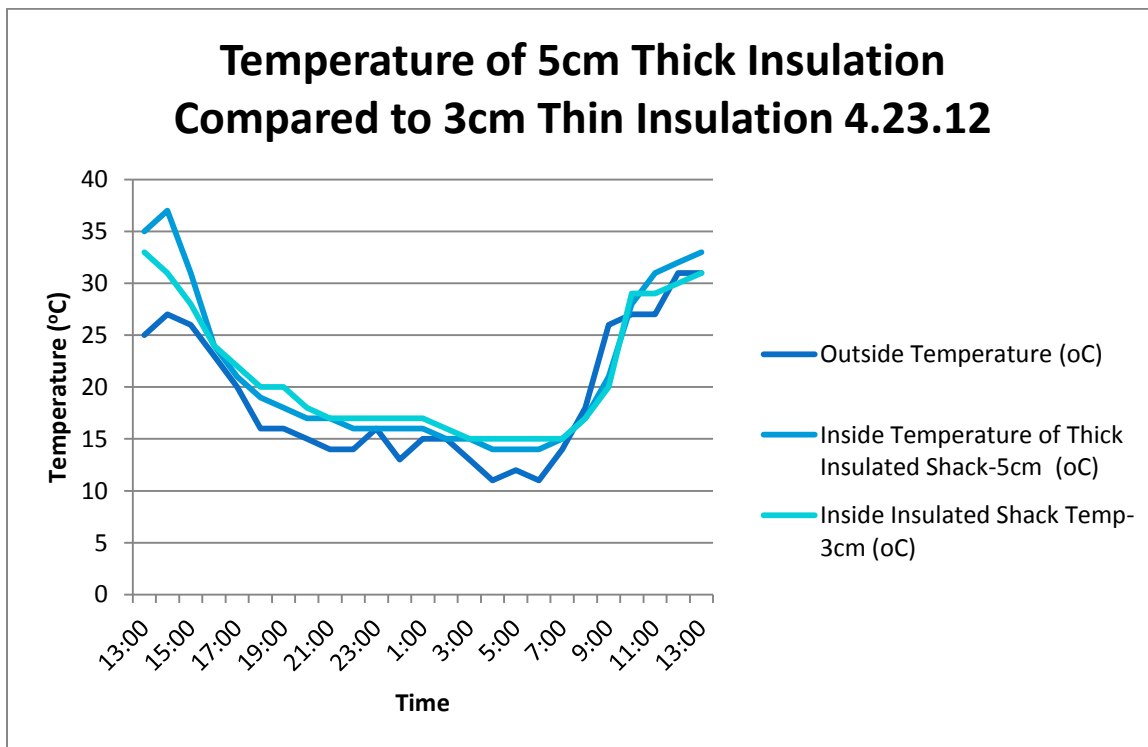

FIGURE 18: THERMAL TEST RESULTS FOR THICK INSULATION VS. THIN INSULATION

**Flammability testing of the paper insulation showed that none of the five insulation mixtures ignited as quickly or as easily as anticipated.**

We speculate that the flame resistance of the insulation is due to the high compaction during the production process, which reduces air voids in the final product. Instead of igniting and producing its own flame, the insulation simply smoldered. When testing the insulation over an open fire, Pius said that he typically breaks the blocks apart and uses paraffin oil to ignite them. Further testing showed that the more paper the insulation mixture has, the higher its susceptibility to fire.

The results changed slightly when we tested the insulation at higher temperatures with a welding torch. The criteria taken into consideration were the amount of time it takes for the block to ignite, how long the block remained ignited in the absence of a constant flame, and the amount of smoke produced. At a much higher temperature than that of a shack fire, the 50 percent more paper block took longer to ignite and produced a flame for a longer period. The 50 percent less paper mixture

proved to be the best in two of the three categories. It ignited after ten seconds, yet it only remained lit for 3.5 seconds. Ten minutes after we concluded testing, only about one tenth of the block burned, as shown in the right hand picture below. We identified smoke and ashes to be the greatest threats when the insulation burned. Ash and smoke reduce visibility and increase breathing difficulty during a fire, which raise the likelihood of a fatality. We determined quantity of smoke and ash produced by the insulation strictly from comparative observations. For complete test details, reference Appendix H. We could not receive a fire classification rating for the insulation easily in Windhoek, so we conducted these tests for preliminary analysis.

The blocks containing a sodium chloride additive showed that the flame did not remain lit longer than seven seconds, and the least amount of the sample had burned after ten minutes. We found that this happened because halogens in salt inhibit the oxidation reaction, thus extinguishing the flame. We also noted that the smoke produced by this sample was much darker and more harmful than the other samples. We found that halogen salts used as flame-retardants could often increase the toxicity of materials if exposed to a prolonged flame source.

In a community meeting, MSR members expressed concern about fire safety. After watching a video of our high-temperature fire testing and attempting to light the bricks themselves with a match, they seemed more at ease.



FIGURE 19: FIFTY PERCENT LESS PAPER SMOKE AND SMOLDERED BLOCK<sup>71</sup>

---

<sup>71</sup> Photograph by Emily Fournier April 2012.

**The 50 percent less paper mixture was the most efficient to produce because it was easy to stir and did not require extra time to soak or dry compared to the standard mixture.**

The composition of the paper pulp was critical to the production of the insulation. We found that in order to hold the form of the block, we must stir the mixture well. If not, it prolonged the production process by a minimum of two days because the mixture needed to soak longer. The newspaper mixture was not difficult to stir, but required one more day of soaking and one more day of drying compared to the other mixtures. Therefore, the newspaper mixture received the lowest ranking for ease of production. The mixtures with the least amount of paper were the easiest for us to stir and dried in the same amount of time as the other samples.

**Most community members prefer the 50 percent less paper or standard mixture because they are the lightest and safest, and almost everyone interviewed expressed interest in becoming involved with the project.**

Our group found that everyone we talked to was highly interested in an affordable insulation product. At the community meeting for MSR members, we held a short presentation about the insulation project and distributed several surveys to the members. From this survey, we found that eleven of fourteen people prefer the standard or 50 percent less paper mixture. We also learned that most people like the appearance as it is, but would also like colored options. Thirteen of fourteen members expressed interest in using this product and twelve of fourteen were interested in becoming involved in the project. Janet explained to us that she priced the paper blocks by asking community members what they would pay and ensuring that the price was less than the equivalent amount of wood. We asked the MSR members what they would pay for a sheet of insulation and a majority of them said that they would pay two to five Namibian dollars for an insulation sheet. Some of the data received from these surveys had a large variety of responses. Our group suspects that this is because some members who completed the surveys did not fully understand the presentation we gave about the insulation project. One question we asked was what color residents would like the insulation painted. Most members chose white because they thought that it was clean and would keep the kambashu cooler than a darker colored insulation.

---

### SUMMARY

---

After thorough testing of the various insulation mixtures, we analyzed the information gathered to determine the optimum mixture in terms of fire and water resistance, ease of production, cost, and community preference. We weighted each category evenly to determine the overall ranking of the

insulation. **Based on this ranking system, found in Appendix I, it was determined that the 50 percent less paper mixture was the best to produce insulation sheets for the large-scale tests.** We drew this conclusion from the basic, small-scale tests that we conducted. The technical tests and societal input allowed us to choose the best insulation mixture for large-scale testing. The efficiency and other properties of the insulation may be different after MSR conducts large-scale tests.

## V. IMPROVEMENTS TO MARKETING TECHNIQUES

---

**We found that residents wanted to see the functionality of the paper blocks before purchasing them.**

When visiting the townships of Freedomland, Hakahana, Havana, and One Nation, the marketing of paper blocks received a predominantly positive response. Most residents spoke in Oshiwambo, but Pius and Magdalena translated. They told us that residents were curious as to the contents of the boxes that we carried the blocks in. We found that many people walking by stopped to see what everyone was looking at. The large congregation allowed us to sell the paper blocks and raise awareness of MSR to many members of the community of all ages.

Curiosity drove the public reception of the paper blocks, but curiosity alone did not generate sales. The first things locals did with the paper blocks were smell them, touch them to test the hardness, and weigh them in their hands to see how they compared to firewood. Most people bought one or two blocks; however, some people bought four to six blocks, while others bought none at all. We asked Magdalena and the locals for explanations to understand why people were buying two blocks or less. Residents who purchased one block stated they wanted to test the product before buying a large quantity. For those who bought none, Magdalena explained that even when residents know that the blocks are a substitute for firewood, they want proof of their functionality at no cost to them. At one Namibian dollar, most residents admitted the price was not the largest deterring factor. We noted that performance of the blocks does not guarantee increased sales because the properties of the blocks that are different from firewood concerned people.

The purpose of going into the community was to not only sell the paper blocks, but also raise awareness of MSR. We asked for feedback on how to improve sales and promote MSR. In Havana, we met an individual named Michael, who showed great interest in the Paper Block Project. He told us that people travel kilometers daily to illegally chop down trees, and sell them as firewood. Michael only bought a single block, yet he acknowledged the benefits of substituting firewood with paper blocks. He



also gave us two suggestions. The first was to visit the townships a day in advance in order to explain how the blocks work and what MSR does before selling the blocks. He said that a demonstration would build anticipation for selling the blocks the next day and people would have time to prepare to buy them. This method would also benefit MSR representatives because they could dedicate one day to promotion and one to sales. His second suggestion was to sell the blocks around five in the afternoon so MSR members could demonstrate the use of the blocks around dinnertime when most people are cooking and would use the blocks. We determined that these suggestions could apply to the marketing of the Paper Insulation Project. A demonstration would show community members how insulation works and allow them to feel the cooling effects. We found that several techniques could improve the marketing of the Paper Block Project and benefit the marketing of the paper insulation and MSR.

## CHAPTER 5: CONCLUSIONS AND RECOMMENDATIONS

---

After multiple field visits, interviews, and experiments, our group has established the following guidelines for the creation and future implementation of a sustainable Paper Insulation Project in Katutura, Namibia. These recommendations are separated into five categories: I. Next Steps for Developing Paper Insulation, II. Marketing Strategies for the Paper Block and Paper Insulation Projects, III. Growth and Implementation Techniques for MSR, IV. Proposed Future WPI Projects, and V. Technology and Society.

### I. NEXT STEPS FOR THE DEVELOPMENT OF PAPER INSULATION

---

**We recommend that MSR perform proper fire testing on the 50 percent less paper insulation mixture through the Worcester Polytechnic Institute Fire Protection Engineering Department.**

We concluded from interviews that insulation on the roof of kambashus would not increase the occurrence of shack fires because candles that are located far from the roof cause most fires. Our results from preliminary fire testing suggest that the insulation has a low flammability compared to other materials found in the shacks such as clothes and cloth dividers and therefore does not present a significant fire risk. However, we based this conclusion on informal testing. *We recommend that MSR conduct standardized fire testing so that the insulation may be designated a fire classification.* Determining the fire classification of the insulation would allow us to identify the risks of implementing insulation in fire prone kambashus. Community members may not understand the importance of a fire classification; however, it will provide MSR with the assurance that their product is safe for use in kambashus.

*We recommend that MSR obtain fire ratings of the paper insulation through Worcester Polytechnic Institute's (WPI) Fire Protection Engineering Department.* In order for WPI to conduct fire testing, MSR will need to send between six and twelve 100-millimeter-by-100-millimeter samples of the insulation to the department, as these are the specifications requested by WPI. *We also recommend continued research into other affordable additives, such as halogenated salts, which can reduce the fire rating of the insulation.* We recommend that MSR send the 50 percent less paper mixture and the 50 percent less paper with the relevant additives to WPI to obtain the fire rating comparisons. We have begun this process by preparing samples of the 50 percent less paper insulation and the 50 percent less paper insulation with sodium chloride salt to deliver to WPI.

**We recommend that MSR produce a fully functional mold and press for the paper insulation based on the preliminary design for the prototype.**

After testing the prototype mold, shown in Appendix N, to see if it could effectively create insulation sheets, we determined that the new design was functional. The new shape reduces the number of vertical gaps so that air circulating within kambashus has difficulty escaping. By creating a sheet that interconnects on all four sides, there is a reduction of thermal gaps. The insulation sheets fit into one another without affecting the overall thickness. The mold also produces sheets of insulation that are easy to transport.

Since the mold used is only a prototype, it is not perfectly square, creates insulation that is slightly thicker than desired, and does not have a proper pressing mechanism. Therefore, *we recommend MSR consult with Central Metal Works (CMW) to address the problems encountered with the prototype when producing a final mold.* Because CMW produced the prototype, they would easily understand the adjustments that need to be made to the mold. These adjustments include making the mold perfectly square and decreasing the depth. To finalize the mold, *we recommend that MSR provide a design to CMW for the pressing mechanism.* This design should incorporate two pieces. The first is a stand on which to place the mold. The second is a lever hinged to an arm on the stand, which facilitates the diagonal pressing motion.

**We recommend MSR perform continued thermal experimentation through large-scale testing.**

We concluded that the paper and sawdust mixture was an effective insulator for the kambashu models and justified progress of the insulation project. From our small-scale testing, we found that the most effective insulator was the 50 percent less paper mixture. Performance of the insulation may differ over a longer period, during a different season, or in a larger corrugated metal shack. We found that kambashu residents are most uncomfortable during the summer months, which is outside the time frame of this project. In order to address this, *we recommend the implementation of a large-scale test to observe insulation performance in realistic settings over the course of a year.*

MSR members or other community members may volunteer their kambashus for testing. To ensure safety, MSR should obtain fire ratings for the insulation prior to large-scale testing. MSR members who wish to participate in the sale of insulation should perform the large-scale testing because they will be taking ownership of the project. We have identified two MSR members, Pius and Aser, who volunteered the use of their kambashus for large-scale testing. Pius and Aser should install the fifty percent less paper insulation on the roof of Pius's new kambashu and Aser's kambashu using chicken wire support, as done in the small-scale tests. Pius should use his older kambashu as a control.

## CONCLUSIONS AND RECOMMENDATIONS

In order to implement the large-scale test, *we also recommend that MSR obtain temperature logging systems*. This system will record hourly temperature readings both inside and outside of the test kambashus. Thermometers should be located at similar locations within each kambashu to minimize variables between experiments. MSR members should perform the test over a year to determine effectiveness of the insulation. MSR can then compare the temperature inside the insulated shacks to the control as we have done in small-scale testing. Pius and Aser should check the temperature logging system weekly to ensure that the data is collecting properly. Prolonged testing would provide MSR with information on the insulation's performance and durability. *We recommend MSR compile both qualitative and quantitative information on the insulation's performance*. Collecting qualitative data will provide information on whether or not the insulation affected the resident's comfort throughout the year. This is a far more important factor to residents than a quantitative explanation of the insulation's effectiveness at regulating temperature.

**We recommend MSR require that a kambashu is waterproof prior to the installation of the paper insulation.**

Through investigation of kambashu construction, we concluded that waterproofing the kambashu is required prior to installation of insulation. Approximately half of the residents interviewed and surveyed stated that their kambashus leaked when it rained. *Without the use of waterproofing techniques, we do not recommend the installation of paper insulation* because water damage causes the insulation to break apart rendering it ineffective. Paper insulation exposed to water may also cause mold to form, presenting a health hazard to residents. We have determined that most chemicals necessary for waterproofing paper insulation are not cost effective or readily available. *We recommend that MSR develop a method to educate residents on common waterproofing techniques and the detriment of water to the integrity of insulation*.

We found that common waterproofing practices include foam-forming glue, bottle cap washers, waterproofing membrane and paint, and proper construction techniques. These construction methods consist of sloped roofs, elimination of gaps, and flush corners. Waterproofing membranes and paint cost approximately N\$40, bottle caps are free, and foam-forming glue is approximately N\$60. *We recommend an investigation of public opinion on waterproofing options that concentrates on cost, convenience, durability, and appearance*. MSR should present these practices in a pamphlet with pictures and cost for potential consumers of the insulation. This is a practical requirement for the insulation because our community survey showed that five out of the six people who stated they had leaks also stated that they would be willing to spend money to mend them.

### **We recommend that MSR look into ventilation techniques that are water resistant.**

In our community visits we observed other cooling methods used in kambashus. We found that most community members do not cool their homes and instead stay outside during the summer or leave the door open. Through our observations, we concluded that most shacks do not have ventilation due to weatherproofing methods used. Cloth or plastic in the corrugation and waterproofing membranes create a seal from outdoor exposure. Research shows that ventilation is a powerful cooling source. *We recommend that MSR investigate water resistant ventilation techniques and inform the community of these techniques.*

Some possible ventilation techniques are whirlybirds or vents covered by awnings. Whirlybirds are turbines that can be installed on roofs and create ventilation inside when the wind spins the turbine. Putting an awning over a vent near the roof would also allow wind to circulate, but rain should flow off the awning rather than leak in through the vent. MSR can investigate the feasibility of these two options in terms of cost, water resistance, and cooling effects. These options as well as other ideas may also improve thermal comfort inside kambashus.

## II. MARKETING STRATEGIES FOR THE PAPER BLOCK AND PAPER INSULATION PROJECTS

---

### **We recommend that MSR members localize the sale of the paper insulation within their respective communities.**

MSR is looking for ways to get members more actively involved in their various projects. Currently, approximately ten members are involved in the Paper Block Project and of these ten members, only two are actively selling the blocks among the communities. In order for future implementation of paper insulation to be feasible, further involvement of the community is necessary. *We recommend that MSR localize the sale of both the Paper Insulation Project and the Paper Block Project to the various townships within Katutura.* To localize, MSR members can by sell paper blocks or insulation from their homes or stores within the community rather than taking boxes of the product from the MSR office to sell.

A central location of sale is important for the insulation because covering a roof requires a large quantity of the material. It is not practical to sell the insulation on foot for this reason. Localization would decrease cost of transportation back and forth from the MSR office. Establishing sale locations throughout Katutura would also allow MSR to increase the exposure of its products and initiatives to residents. *We recommend increasing the proximity of MSR to ISAs in order to encourage the entrepreneurial mindset that makes the Paper Insulation and Paper Block Projects self-sustainable.* Presently, MSR members believe that they deserve compensation for their labor as opposed to the sale of the product. Localizing the insulation would make purchasing the product more convenient for

Katutura residents, which could potentially facilitate the assemblage of positive public opinion and perspective of the insulation. Additionally, this technique will improve the overall marketing of the MSR organization by increasing exposure.

**We recommend that MSR members develop a demonstration for sale of the paper insulation.**

Through observations of paper block sales, we concluded that the sale of the paper blocks was dependent on demonstrations and explanations of its performance. We found that residents wanted to know how the blocks were made, how they worked, and how long they burned. Most consumers purchased only one block because they wanted to test it before purchasing more. *We recommend further investigation into the marketing strategies to increase public awareness of the Paper Block and Paper Insulation Projects.*

Because most residents requested a demonstration of the paper blocks, *we recommend the development of a demonstration of the paper insulation to provide evidence for the insulation's usefulness.* MSR members can do this by installing insulation in the Kambashu constructed for sale of the insulation. Customers who entered the place of sale would be able to see how MSR members mount the insulation on the roof and feel the cooling effects it provides. *We also recommend MSR build a small mobile kambashu with insulation so that MSR members can transport into the community to demonstrate the insulation's effects.* A mobile kambashu would allow a larger number of people to experience the insulation demonstration and increase interest in the product.

**We recommend MSR members develop a name for the insulation and use informational pamphlets and signs as a mean of marketing.**

In our participation of selling the paper blocks, we noticed that most people wanted to read the informational pamphlet provided. For this reason, we developed a similar pamphlet for the Paper Insulation Project. The pamphlet our group created explains what paper insulation is in a simple way so that everyone can understand it. Circulation of the pamphlet may enhance public understanding of the project. A challenge we faced in explaining the insulation to member of the community was that there is no word in the Oshiwambo language for "insulation". *We suggest that MSR members create a name for the paper insulation.* As information about the insulation spreads, community members will not need any further explanation of what the insulation is. *We also recommend that MSR members make signs for the insulation at sale locations.* The signs can include the newly developed name of the insulation along with a short and catchy description. Additionally, all marketing strategies should use simple explanations.

MSR should also continuously monitor the success of implemented marketing strategies to identify whether or not they are successful in spreading awareness of the Paper Insulation Project throughout local communities. MSR can do this in various ways, such as going into the communities and talking to residents to see if people are becoming more aware of the project, and cataloging the sale of

insulations sheets. By collecting such information, MSR can identify areas of improvement within the marketing of the project.

### III. GROWTH AND IMPLEMENTATION TECHNIQUES FOR MSR

---

**We recommend that MSR practice community driven implementation in the Paper Insulation Project and future projects.**

Through community interviews and presentations, our group discovered that community feedback was invaluable. We formed our ideas for waterproofing, marketing, and implementation with the input of community members. *Our group recommends that MSR continue to obtain suggestions for similar issues from residents of Katutura.* We also found that a substantial amount of time was spent explaining the purpose of our project and the general concept of insulation. *We recommend that the community be actively involved in all further testing, development, and implementation of paper insulation throughout Katutura.* Involvement should include further interviews, implementation of large-scale testing within the community, and development of a community demonstration. Having community members actively participate in the entire process of developing the paper insulation will increase receptiveness to the project. We suggest involving community members in order to obtain unbiased feedback on the performance of the insulation. Lastly, involving the community will ensure personal commitment to the success of the Paper Insulation Project.

Further involvement of community members can be a difficult task to accomplish if motivation is lacking. In order to combat this problem, current MSR members could initiate the involvement of individuals within their respective communities. By demonstrating the use of insulation in their neighborhoods, they could help community members understand the benefits of this project. Using a familiar face as the representative for this project could also improve community reception.

**We recommend that MSR develop a partnership with organizations that have overlapping goals.**

From interviews, we found that shacks are dark inside during the day due to a lack of electricity and windows. Therefore, residents commonly use candles for lighting. Most fires that occur during the day happen because unsupervised children knock over the candles. To address this problem, The Namibia Solar Bottle Program offers a safe alternative light source described in Appendix F. This program complements the installation of insulation because it works to limit the risk of fires. Stopping fires from occurring is more effective than fireproofing the insulation itself.

*We recommend that MSR work in conjunction with other organizations and projects that may complement or affect the Paper Insulation Project.* Coupling projects may increase awareness of solutions to common problems in ISAs, like fire safety. By doing so, MSR could initiate large-scale programs to improve various aspects of kambashu living conditions. *We recommend that MSR look into*

*the Namibia Solar Bottle Program, to mitigate the threat of fires in kambashus.* This partnership would likely increase fire safety by alleviating the use of common fire hazards and ease public concern for the insulation's susceptibility to fire.

### IV. RECOMMENDATIONS FOR FUTURE WPI PROJECTS

---

#### **We recommend a project dedicated to the analysis of large-scale testing data and implementation of the Paper Insulation Project**

*We recommend that a future WPI team analyze data from the large-scale testing for performance and durability of the material.* Future research teams should assess both thermal resistance of the insulation and damage to the insulation in a large-scale test over a year's time. From observations of paper block sales we found that potential customers wanted to know if the paper blocks worked and how long they burned. This analysis of large-scale tests should serve as proof of performance to residents. The following research questions should be addressed following large-scale testing.

- Is there damage to the insulation due to water, moths, or other unforeseen factors?
- What is an approximate life span of the insulation?
- How did the temperature in the insulated shacks compare to the control during the summer, winter, and at night?

Future project teams can make this assessment through observations of the insulation after a year, data from the temperature logs over the year and extensive interviews with residents of the insulated kambashus. Additionally, future WPI teams should assess how the insulation has affected thermal comfort of residents. They can ask the following questions to gauge community reception to the insulation.

- Did the residents of the insulated shacks notice a difference in temperature compared to other years or other kambashus?
- Were they more or less comfortable?
- Did the residents experience any unexpected consequences from the insulation?

This analysis of data will provide MSR with valuable information that the organization can use to further improve the insulation project.



### **We recommend a project dedicated improving the entrepreneurial mindset of MSR members.**

Some MSR members would rather be paid for the labor involved in making the blocks rather than use the project as a business opportunity. MSR would like its members to take ownership of the Paper Block Project and Paper Insulation Project and initiate sales in the community. Currently, out of the ten members involved in the Paper Block Project, only two are actively selling the blocks in the community. Future research groups should investigate why the project is lacking participation by interviewing MSR members. Future research groups can also look into how the mindset affects other aspects of the job hunt. Some questions that should be asked include the following.

- Do you sell paper blocks in your neighborhood? If not, why not?
- What can MSR do to help you sell the blocks?
- What is preventing you from participating?
- Is there someone else besides MSR that can assist you?
- Are there any other training programs that MSR could offer to help increase your participation?
- Do you like the Paper Block Project?

From the responses gathered, a plan to address the issue can be developed. This may involve an educational program on the benefits of actively participating in business opportunities.

### **We recommend a project dedicated to the creation of employment opportunities for MSR members by developing a waterproofing service and installation service for the paper insulation.**

We did not design the insulation mixtures to be waterproof. Instead, our group concluded that it would be more cost effective to mend shack leaks before installing insulation in a kambashu. To simplify this process, we recommend that MSR investigate the option of providing a waterproofing service along with installing the paper insulation. The study should look at a variety of products and factor in accessibility to the material. Not all residences have the same degree of difficulty with water leakages. Some have sloped roofs that run the water off the side or have already applied waterproofing membranes to their kambashus, while others simply place buckets under the leakage source. Results from this study will aid in establishing a solution to waterproofing insulation that satisfies the majority. *We recommend a future WPI team conduct a study on community preference between different waterproofing methods.*

We suggested that Katutura residents install the insulation by attaching chicken wire across the wooden frame of the kambashu. Chicken wire is strong enough to hold the lightweight paper insulation and is cheap and readily available. Upon sale of the insulation, MSR members could offer to install the insulation for an additional price. *We recommend that a future WPI team should organize the logistics*

*of the installation and waterproofing services.* Factors to consider include demand for the service, reasonable pricing, and regulations.

### V. TECHNOLOGY AND SOCIETY

---

**The purpose of completing a project in the developing world is not simply to develop a solution but to ensure that the solution addresses the desires of the community it targets.**

When approaching a project that couples technology with a social component it is critical to cater any solution or suggestions to the unique circumstances of the region. Regardless of how innovative the project is, it is of no use if the community does not agree with the change. A group must first establish the need for their project. It is essential to identify whether the project topic currently has a solution, and if so, how people feel about that particular solution. The relationship between technology and society requires that projects develop practical solutions that address the community's needs. If the community is satisfied with existing conditions, then it is important to gauge their receptiveness to an alternative solution. If society does not have a desire for, or will not use whatever solution a project creates, then it will be ineffective. The social conditions of a region also affect the practicality of technology. If a project is intended for a low income demographic, then a solution should likely be simple and affordable. If a technical solution is intended for non-technical individuals, then explanations about the functionality and purpose of the solution should be direct, simplistic, and use colloquial language.

**The social and natural regional environment could also present constraints that may characterize the technological approach to a project.**

It is likely that one region of the world has a solution for the same problem another region experiences; however those solutions may not necessarily be applicable. For example, when researching low-cost insulation projects our group found a similar project in Northern Pakistan called the Ghonsla project. While the Ghonsla project provided valuable information for the production of low-cost insulation, the materials used in the product are not readily available in Namibia, and therefore renders the solution impractical. For other projects, factors such as economic power and access to an adequate labor force may affect the standardization of a solution. Depending on the region and who the project addresses, convention and tradition may also present a similar problem. Often tradition plays such a large role in society that it supersedes any technical explanations. Though factors such as these may

initially appear to be constraints, they compel groups to strive for unconventional and unique technological approaches.

**Since it is almost impossible to anticipate how a community in a foreign country will respond to a solution, it is important to keep a broad perspective of the problem leading up to a group's time abroad.**

When planning a project in a foreign country it is difficult to fully grasp the circumstances that form the foundation of a project. While research and long distance interviews are helpful, they are no substitute for direct exposure to the problem. Once a group finds itself in a foreign country it is helpful to identify key factors pertaining to their project in order pinpoint what the problem actually is. Often, the simplest manner to accomplish this is through conducting interviews with individuals the project affects, whether they are professionals or locals. This does not only develop the direction of a project, but also provides insight on how to do so. Typically, technological and social problems have many solutions, and those solutions may cause groups to add components to their projects. By keeping a broad perspective of the problem and allowing for flexibility in methodological approaches, the preliminary information gathered from interviews could also bring some new factors into perspective, which were not immediately apparent. As a result, if a community does not react as anticipated then a group can redirect their efforts with minimal setback. Technological solutions, by nature, are a constant work in progress. For that reason, it is beneficial to recommend improvements, so that society may choose to either enhance or weaken the role that technology plays on their lives.

## BIBLIOGRAPHY

---

- Climate Windhoek - Khomas." climatedata.eu, <http://climatedata.eu/climate.php?loc=waxx0004&lang=en>.
- "Council of Scientific & Industrial Research Files Patent Application for a Process for the Preparation of Water Repellent Chemical Useful for Making Water Proof Cellulose Based Textile Materials." *Indian Patents News*, 2011a.
- "Men on the Side of the Road Namibia", accessed January 20, 2012, <http://www.msr.org.na/>.
- "Namibia Climate." (2009). <http://www.namibia-1on1.com/information/climate.html>.
- "NAMIBIA: Employment Survey." *Africa Research Bulletin: Economic, Financial and Technical Series* 47, no. 9 (2010): 18835A-18835B. doi:10.1111/j.1467-6346.2010.03492.x.
- "NAMIBIA: Unemployment Up." *Africa Research Bulletin: Economic, Financial and Technical Series* 43, no. 5 (2006): 16966A-16966B. doi:10.1111/j.1467-6346.2006.00265.x.
- "Slums and Informal Settlements." The University of Dublin, Trinity College, [http://www.tcd.ie/Economics/Development\\_Studies/link.php?id=92](http://www.tcd.ie/Economics/Development_Studies/link.php?id=92).
- "Windhoek Population Boom." SWAPO Party, accessed March 20, 2012, [http://www.swapoparty.org/windhoek\\_population\\_boom.html](http://www.swapoparty.org/windhoek_population_boom.html).
- Ali, Zehra. *Sustainable Structures for Post Disaster Reconstruction: An Integrated Approach for Reconstruction After the South Asia Earthquake*: Massachusetts Institute of Technology, 2007.
- CIA. 2008. "Unemployment Rates." *The World Factbook*.
- Glen Salas. "Choosing Insulation." *Professional Builder* 69, no. 8 (2004): 57.
- Godwin, Y., DA Hudson, and CE Bloch. "Shack Fires: A Consequence of Urban Migration." *Burns* 23, no. 2 (1997): 151-153. doi:10.1016/S0305-4179(96)00118-0.
- Ihuhua, C. and S. Ikela. 2011. "Rain: A Shack Dweller's Worst Nightmare." *Namibian Sun*, December 9, 2011.
- Jarvis, Alice, John Mendelsohn, Carole Rovers, and Tony Rovers. *Atlas of Namibia*. Second Edition ed. Cape Town, South Africa: David Philip Publishers, 2003.
- Mahbubur Rahman. "Sustainable Squatter Housing in the Developing World: Changing Conceptualization." *Archnet-IJAR : International Journal of Architectural Research* 5, no. 1 (2011): 143-159.
- Mathews, E. H., P. G. Richards, S. L. Van Wyk, and P. G. Rousseau. "Energy Efficiency of Ultra-Low-Cost Housing." *Building and Environment* 30, no. 3 (1995): 427-432. doi:10.1016/0360-1323(94)00061-V.
- Mathews, E. H., S. Weggelaar, and S. L. van Wyk. "The Development and Testing of Low-Cost Insulation for Shacks." *Energy and Buildings* 29, no. 3 (1, 1999): 307-313. doi:10.1016/S0378-7788(98)00040-1.
- Middleton, John and Joseph C. Miller. 2008. "Urbanism and Urbanization." In *New Encyclopedia of Africa*. 2nd ed. Vol. 5, 134-165. Detroit: Charles Scribner's Sons.  
<http://wpi.summon.serialssolutions.com/link/0/eLvHCXMwQ4wAIIcHRkSUB8CqUtlfIEO3-CPi8Quox7jSgP4gSASoA6wI5hcgYVlck5->

[AWhDCLiVCb4HCDlhhBYlJeaBrsZwzEvRhnCqENED6\\_MZmFkAK30TU8hIn7BCzBSpEDKEDg9C6jNDyF0MaKdKg2bXQFWVbBaTnaAK69cLTNxyeFc0tQCd9GcGHq4DKjYFVPahfC7PfehP-Edw90FoNqX4OEWtgAe3ZUABtpgBaL8TAljrH58x0rv-Ko3tdj0zBE-3M6MsAPgSw3w.](http://www.az.com.na/fileadmin/pdf/2011/az/Arbeitsmarkt-Bericht-05-10-11.pdf)

Ministry Labour and Social Welfare. "Namibia Labour Force Survey 2008." , accessed January 21, 2012, <http://www.az.com.na/fileadmin/pdf/2011/az/Arbeitsmarkt-Bericht-05-10-11.pdf>.

Mumford, Andrew J., Jessica A. V. Sulzmann, and Jesse D. Tippet. *Energy Efficiency Guidelines for Low-Cost Housing*: Worcester Polytechnic Institute, 2004 May 4.

*Namibian Environmental Directory*. (2004). Retrieved January 18, 2012, from The Kayec Trust: <http://www.nnf.org.na/ENVDIR/pages/kayec.html>.

Norford, LK, LR Glicksman, HS Harvey, and JA Charlson. "Development of Low-Cost Wheat-Straw Insulation Board." *HVAC&R RESEARCH* 5, no. 3 (1999): 249-263.

Oppenheimer, Jonathan and Michael Spicer. 2011. "Creating Employment in Africa."

Pendelton, Wade C. *Katutura: A Place Where we Stay: Life in a Post-Apartheid Township in Namibia* [This book from]. Vol. 65. Windhoek, Namibia: Ohio University for International Studies, 1993.

Pharoah, Robyn. "Fire Risk in Informal Settlements in Cape Town, South Africa." In *Disaster Risk Reduction: Cases from Urban Africa*, 105. London: Earthscan, 2009.

Schmidt, Anders C., Allan A. Jensen, Anders U. Clausen, Ole Kamstrup, and Dennis Postlethwaite. "A Comparative Life Cycle Assessment of Building Insulation Products made of Stone Wool, Paper Wool and Flax: Part 2: Comparative Assessment." *The International Journal of Life Cycle Assessment* 9, no. 2 (2004): 122-129. doi:10.1007/BF02978571.

Taylor, P. B., E. H. Mathews, M. Kleingeld, and G. W. Taljaard. 2000. "The Effect of Ceiling Insulation on Indoor Comfort." *Building and Environment* 35 (4): 339-346. doi:10.1016/S0360-1323(99)00025-6.

The Shack Dwellers Federation of Namibia. *Community Land Information Program (Clip)-Profile of Informal Settlements in Namibia March 2009*, 2009.

Wright, Lindsay, Elizabeth Norgard, and Christopher Bean. *Energy Efficiency in Low-Cost Housing*. Worcester Polytechnic Institute: 2003, 2003.

---

## APPENDICES

---

### APPENDIX A: MSR HISTORY AND MISSION

---

The Men on the Side of the Road (MSR) project is a charity organization founded in 2001 in South Africa to “address the plight of unemployed men who congregate daily on the side of the road”.<sup>72</sup> This organization was created to combat the pressing issue of unemployment facing the South African population. Unemployment is an issue in many nations throughout Africa. In South Africa alone forty percent of the population is unemployed. After the founding of MSR in South Africa, the organization branched out to other countries including Namibia. The organization first started in Namibia in 2007 when a local church assisted the unemployed men that gathered across the road. The project began in September of 2007 at the Eros NG Kerk Church when the Minister of Labour, the Honourable Alpheus INaruseb, addressed those present. Within the following four months, 86 people were connected with job opportunities.<sup>73</sup>

The purpose of MSR is not to give people jobs, but to provide them with the “physical and mental tools” that will make them more successful in the job market and in life.<sup>74</sup> MSR provides the unemployed with basic necessities to improve and develop various skills by creating training seminars and skill development programs. MSR proceeds to help men that choose to undergo these programs by creating job and placement programs. MSR also frequently forms partnerships with organizations that serve a similar purpose. By doing so, MSR not only offers new opportunities to those who seek aid from their organization, but also develops projects that allow Namibians to apply their acquired skills. MSR provides companies with information on individuals who are semi-skilled or unskilled and looking for employment. Overall, the purpose of MSR is not to fight unemployment but rather its source in an attempt to provide a self-sustainable work force that increases self-esteem and brings dignity and pride to the impoverished.<sup>75</sup>

After its opening at the Eros job site, the first MSR office opened in Maerua Mall with only three staff members. Since then, MSR has teamed up with various organizations in an attempt to raise awareness of their mission. Starting in 2008 MSR secured funding through the Pinnacle Metropolitan

---

<sup>72</sup> Men on the Side of the Road, 2007.

<sup>73</sup> Progress Report April 2011, 2011.

<sup>74</sup> Men on the Side of the Road, 2011.

<sup>75</sup> Ibid.

Empowerment Trust, an organization that contributes to vocational training. MSR also worked in collaboration with the Deutscher Entwicklungsdienst (DED), transport services, and EMS training academies ultimately adding 10 Code CE licenses to a pool of potential truck drivers. By the end of the year, MSR connected 270 people with job opportunities. In 2009, MSR's first trainees attended the Kayec trust, which seeks to "provide young people with practical and marketable expertise that will enable them to become independent, motivated, and productive members of their communities."<sup>76</sup> It also achieved welfare organization status (WO348), which is critical to unlocking donor funding. Lastly, MSR took partnership in the EnviroChance Paper shredding job and began running basic literacy classes. By the end of the year, MSR had developed an effective six-step approach to training and connected 192 more people with job opportunities. Within the last two years, MSR has focused on expansion and increasing public knowledge of their work, securing sponsorship from places such as Bank Windhoek.<sup>77</sup>

One common factor that prevents many Namibians from being employed is inadequate English language skills. To address this issue, MSR works in partnership with Capacity Building Initiatives of Namibia (CABIN) to host English courses. This project was funded through the Namibian Literacy Trust. Basic computer skills courses and individual assistance is also available to MSR members. The Canadian Fund for Local Initiatives and Metropolitan Pinnacle Empowerment Trust funded basic job center resources to empower MSR members. With this resource, they can gain basic computer skills, search for employment opportunities, and access phones, email, fax, and printing services, which are vital to the success of MSR members searching for long-term employment.<sup>78</sup>

Two of the projects that MSR is currently working on are EnviroChance and the Paper Block Project. Both of these projects deal with recycled office paper. EnviroChance takes non-confidential and confidential documents from local businesses and then shreds them. The product is then used as a packaging material. The Paper Block Project also utilizes recycled office paper. For this project, the paper is shredded and then compacted together with sawdust into brick-sized blocks. These blocks are used in the absence of firewood. For both of these projects men are needed to haul the office paper to a shredding facility as well as to shred the paper upon arrival.<sup>79</sup>

In order to ensure that the project remains on track and makes decisions in accordance to its goals, the Men on the Side of the Road project is led by a board of directors. This board is currently

---

<sup>76</sup> Namibian Environmental Directory, 2004.

<sup>77</sup> Progress Report April 2011, 2011.

<sup>78</sup> Men on the Side of the Road, 2011.

<sup>79</sup> Ibid.

comprised of nine people connected differently to MSR. Some of the directors represent MSR's corporate members and donors, while others focus primarily on developing new training programs. Since all of MSR's funding sources are from private investment, government, or philanthropy funded organizations, the board of directors proves invaluable in maintaining financial statements and positive relationships. Aside from maintaining these relationships, the board has the power to organize committees and initiatives to ensure the growth of MSR.<sup>80</sup>

---

<sup>80</sup> The Men on the Side of the Road, 2011.



## APPENDIX B: COMMUNITY AND MSR MEMBER INTERVIEW TEMPLATES

Hello, my name is \_\_\_\_\_. I am an American student at Worcester Polytechnic Institute. I am collecting information to help the Men on the Side of the Road organization learn about the feasibility of installing insulation in informally settled homes within Katutura.

Your participation in this survey is completely voluntary and you may withdraw at any time. Please know that your answers will remain anonymous. No names will appear in any of the project reports or publications.

This is a collaborative project between MSR and WPI, and your participation is greatly appreciated. If interested, a copy of our results can be provided at the conclusion of the study.

Would you be willing to take a few minutes to answer a few questions?

### Community Member Interview Questions

Gender:	Age:
---------	------

### Construction Questions

<p>1. Where are you from? How is it different in Katutura?</p> <p>_____</p>
<p>2. How long have you lived here?</p> <p>_____</p>
<p>3. Why did you build your house this way?</p> <p>_____</p>
<p>4. What would you like to see changed to improve comfort within your home?</p> <p>_____</p>

**Insulation Questions**

<p>1. How hot is it inside your shack during the day? How about at night?</p> <p>_____</p> <p>_____</p>	<p>2. Is it uncomfortable?</p> <p style="text-align: center;"><b>Yes</b>      <b>No</b></p>
<p>3. (if yes) What do you do to fix it?</p> <p>_____</p> <p>_____</p>	<p>4. Do you know what insulation is?</p> <p>_____</p> <p>_____</p>
<p>5. Do you think insulation will help regulate the temperature?</p> <p style="text-align: center;"><b>Yes</b>      <b>No</b></p>	<p>6. Do you think insulation is safe? Why?</p> <p>_____</p> <p>_____</p>
<p>7. How much money do you spend to heat or cool your home each year?</p> <p>For wood, kerosene, or electricity?</p> <p>_____</p> <p>_____</p>	<p>8. Would you purchase a low-cost insulation?</p> <p style="text-align: center;"><b>Yes</b>      <b>No</b></p>
<p>9. If yes, how much would you be willing to spend?</p>	

**Questions regarding fire and water concerns**

<p>1. What lighting source do you use in your shack? What do you use to cook?</p> <p>_____</p> <p>_____</p>	<p>2. Are you concerned about your shack catching fire?</p> <p>_____</p> <p>_____</p>
---	---

<p>3. How do you protect your home against fires?</p> <p>_____</p> <p>_____</p> <p>_____</p>	<p>4. Does the rain leak through your roof?</p> <p>_____</p> <p>_____</p>
<p>5. Have you tried to mend it? How?</p> <p>_____</p> <p>_____</p> <p>_____</p>	

**MSR Employee Interview Questions**

1. Do you know of anyone who uses insulation in their kambashu? What insulating materials do they use?
2. How easily can these materials be obtained? How much do they cost?
3. Do you think that insulation will be a fire hazard in the shacks?
4. Do you think that we can install the paper insulation in a way which will minimize fire hazards?
5. Are there other materials that can be added to this insulation mixture to improve flame and water resistance?
6. Do you think rain water and leaking roofs will damage the insulation?
7. Do you have any ideas on ways to protect the insulation from water damage? How do you mend leaks in your kambashu?
8. Do you think plastic or reed mats would be more effective as water shields? Why?
9. What is available to us to make a press for the insulation?
10. How was the paper block press made? Can we make something similar?
11. What do you think is the best method for drying the insulation? Sun or wind?

APPENDIX C: PROJECT TIMELINE

This is an expected timeline from our project proposal.

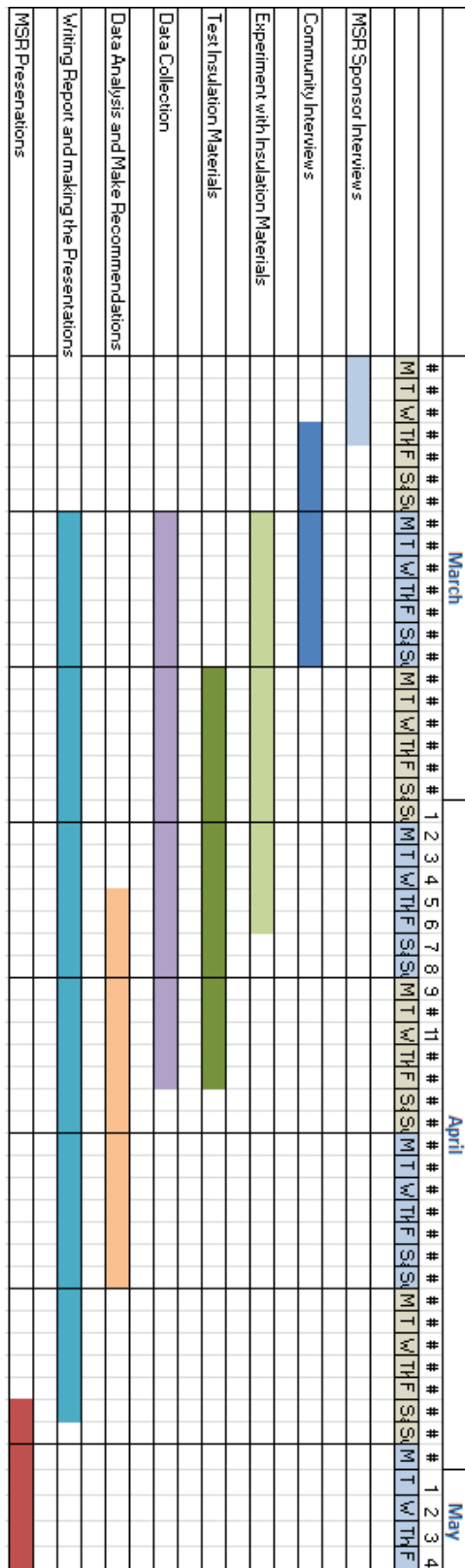

APPENDIX D: STEPS FOR MAKING PAPER BLOCKS

---

**1. Add shredded paper to a metal drum and saturate with water**



**2. Add woodchips and stir**



**3. Repeat; stirring in paper and woodchips with water**



**4. Add water and stir until saturated and completely mixed**





**5. Let mixture soak for a few days**



**6. Press mixture into mold**



**7. Allow blocks to dry in the sun**





APPENDIX E: PHOTO JOURNAL

---



Pius and Marco selling paper blocks to the One Nation community.



View of One Nation, Katutura.



Aser's Kambashu.



Corner joint method.



Waterproof sealant for leaks



Holding roof down with found items.



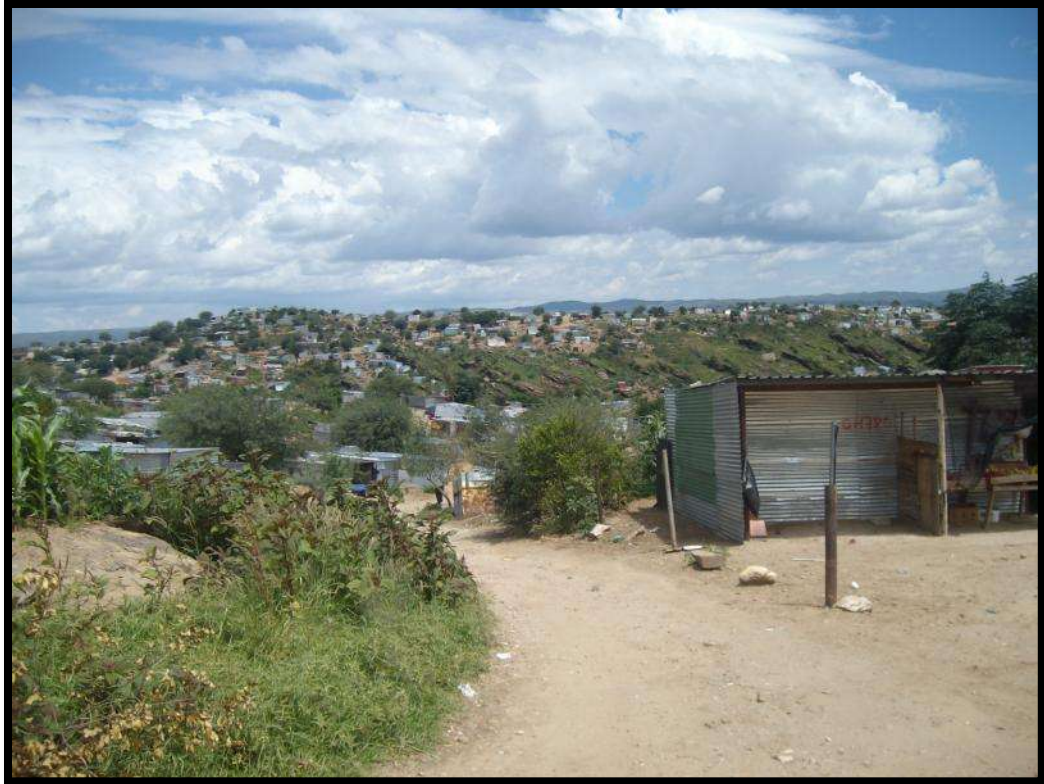

View of Hakahana, Katutura.

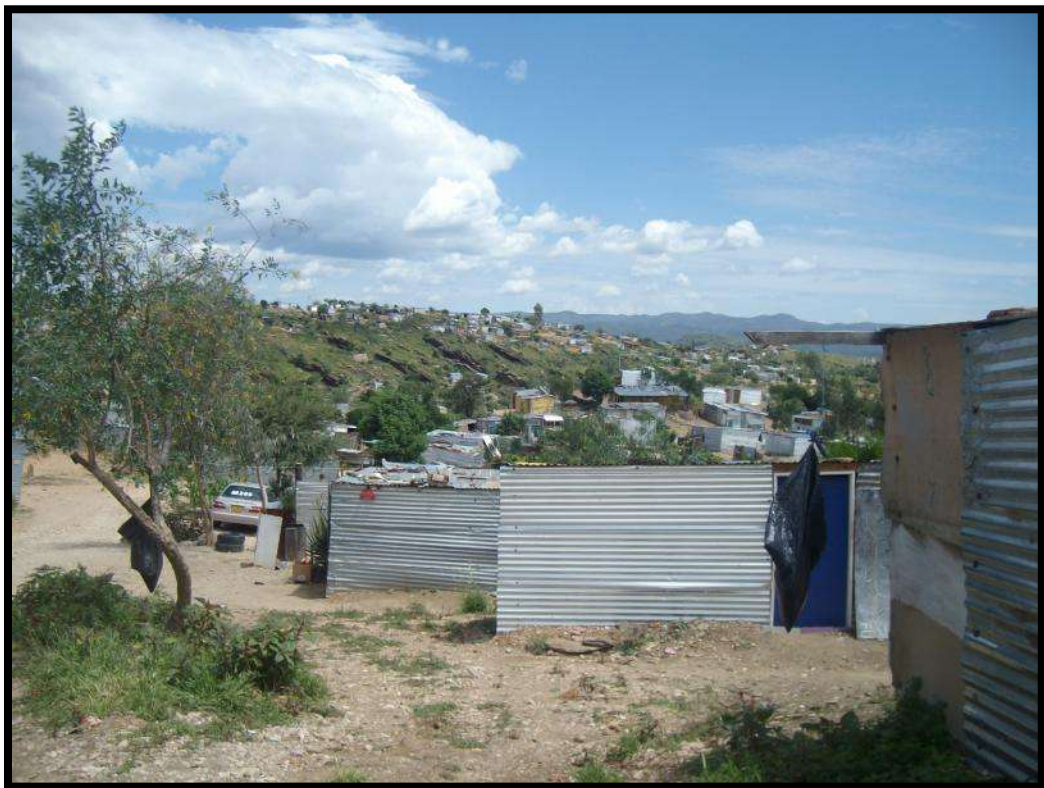

View of Hakahana, Katutura.



Pius' new kambashu showing gaps.



Another joint corner method.



Flashing or waterproofing membrane to protect against leaks and wind.



Blocking gaps from wind and rain.





Insulating and decorative cloth sheets on roof and walls.



Paraffin stoves used by many Katutura residents.



Interactive Community Presentation



MSR Project Team with Pius and Magdalena.



APPENDIX F: NAMIBIA SOLAR BOTTLE PROGRAM

---



The Namibia Solar Bottle Program is a program designed to improve the safety of indoor lighting for kambashus. This lighting project uses plastic Coca Cola bottles filled with water and bleach, which are placed in holes in the roof to produce light. Sunlight, even in shade, is amplified by the purified water and reflects off the metal walls to light the rooms. This technique of lighting is safe and inexpensive. Candles are used throughout the day because there are no windows in the kambashus. With the solar bottles, candles would not be needed during the day thus reducing costs for residents as well as minimizing daytime fires. Utilization of the solar bottles in conjunction with insulation will improve safety, lighting, and thermal regulation in kambashus.



## APPENDIX G: THERMAL TESTING RESULTS

TABLE 4: STANDARD INSULATION TEST VS. CONTROL ON PUCCINI B&amp;B MID-LAWN 4.2.12

Time	Outside Temp (C°)	Inside Control Temp (C°)	Inside Insulated Shack Temp (C°)	Weather Condition	Direct Sunlight	Direct Sunlight	Degrees Difference Daytime: 10:00-13:00	Degrees Difference Nighttime: 18:00-10:00
11:00	31	31	31	Sunny	yes	yes		
12:00	33	27	27	Sunny	yes	yes		
13:00	33	28	28	Sunny	yes	yes		
14:00	31	40	39	Sunny	yes	yes		
15:00	31	41	38	Sunny	yes	no		
16:00	29	30	35	Sunny	yes	no		
17:00	23	23	25	Sunny	no	no		
18:00	21	21	23	Sun setting	no	no		2
19:00	17	19	21	Dark	no	no		2
20:00	11	19	20	Dark	no	no		1
21:00	15	18	20	Dark	no	no		2
22:00	14	17	19	Dark	no	no		2
23:00	13	16	18	Dark	no	no		2
00:00	13	15	17	Dark	no	no		2
1:00	13	15	17	Dark	no	no		2
2:00	11	14	16	Dark	no	no		2
3:00	11	15	16	Dark	no	no		1
4:00	10	15	16	Dark	no	no		1
5:00	10	14	15	Dark	no	no		1
6:00	15	13	10	Sun rising	no	no		-3
7:00	12	14	16	Sunny	no	no		2
8:00	17	17	22	Sunny				5
9:00	27	27	27	Sunny				0
10:00	30	30	29	Sunny			1	
11:00	33	35	30	Sunny			5	
12:00	33	38	32.5	Sunny			5.5	
13:00	34	37	36	Sunny			1	
						<b>Average Degree Difference</b>	3.125	1.5

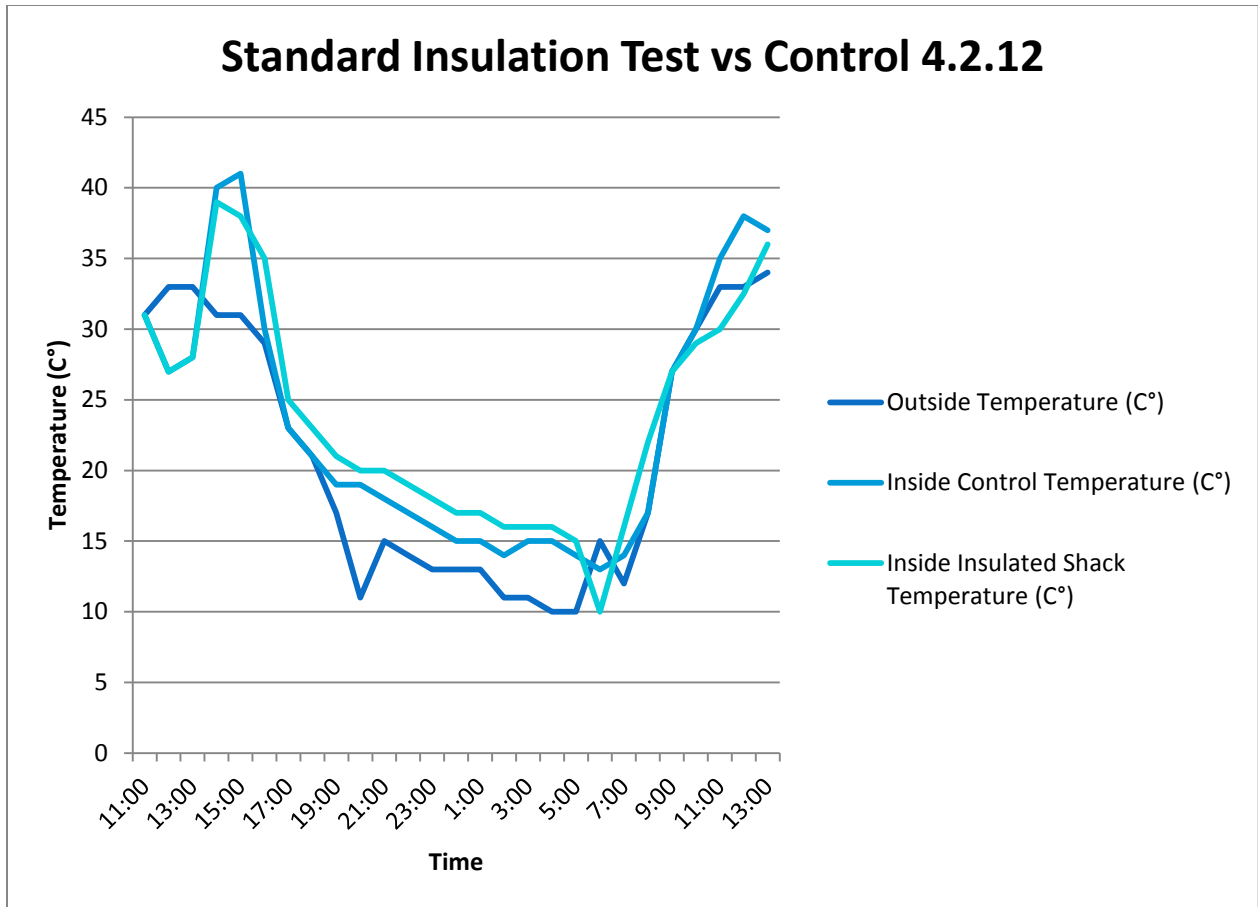

TABLE 5: NEWSPAPER INSULATION TEST VS. CONTROL ON PUCCINI B&amp;B MID-LAWN 4.3.12

Time	Outside Temp (C°)	Inside Control Temp (C°)	Inside Insulated Shack Temp (C°)	Weather Condition	Direct Sunlight	Direct Sunlight	Degrees Difference Daytime: 10:00-13:00	Degrees Difference Nighttime: 18:00-10:00
14:00	34	45	39	Sunny	yes	yes		
15:00	39	45	33	Sunny	yes	yes		
16:00	31	29	31	Sunny	yes	no		
17:00	22	24	25	Sunny	no	no		
18:00	20	21	22	Sunset	no	no		1
19:00	18	19	21	Dark	no	no		2
20:00	17	18	20	Dark	no	no		2
21:00	16	18	20	Dark	no	no		2
22:00	15	17	19	Dark	no	no		2
23:00	14	16	18	Dark	no	no		2
00:00	13	15	17	Dark	no	no		2
1:00	12	15	17	Dark	no	no		2
2:00	12	15	17	Dark	no	no		2
3:00	13	15	17	Dark	no	no		2
4:00	13	15	17	Dark	no	no		2
5:00	13	15	16	Dark	no	no		1
6:00	12	15	15	Sunrise	no	no		0
7:00	13	15	16	Sunny	no	no		1
8:00	18	18	17	Sunny	partly	partly		-1
9:00	27	25	27	Sunny	yes	partly		2
10:00	29	28	28	Sunny	yes	yes	0	
11:00	28	30	29	Sunny	yes	yes	1	
12:00	30	34	30	Sunny	yes	yes	4	
13:00	34	36	35	Sunny	yes	yes	1	
						<b>Average Degree Difference</b>	1.5	1.5

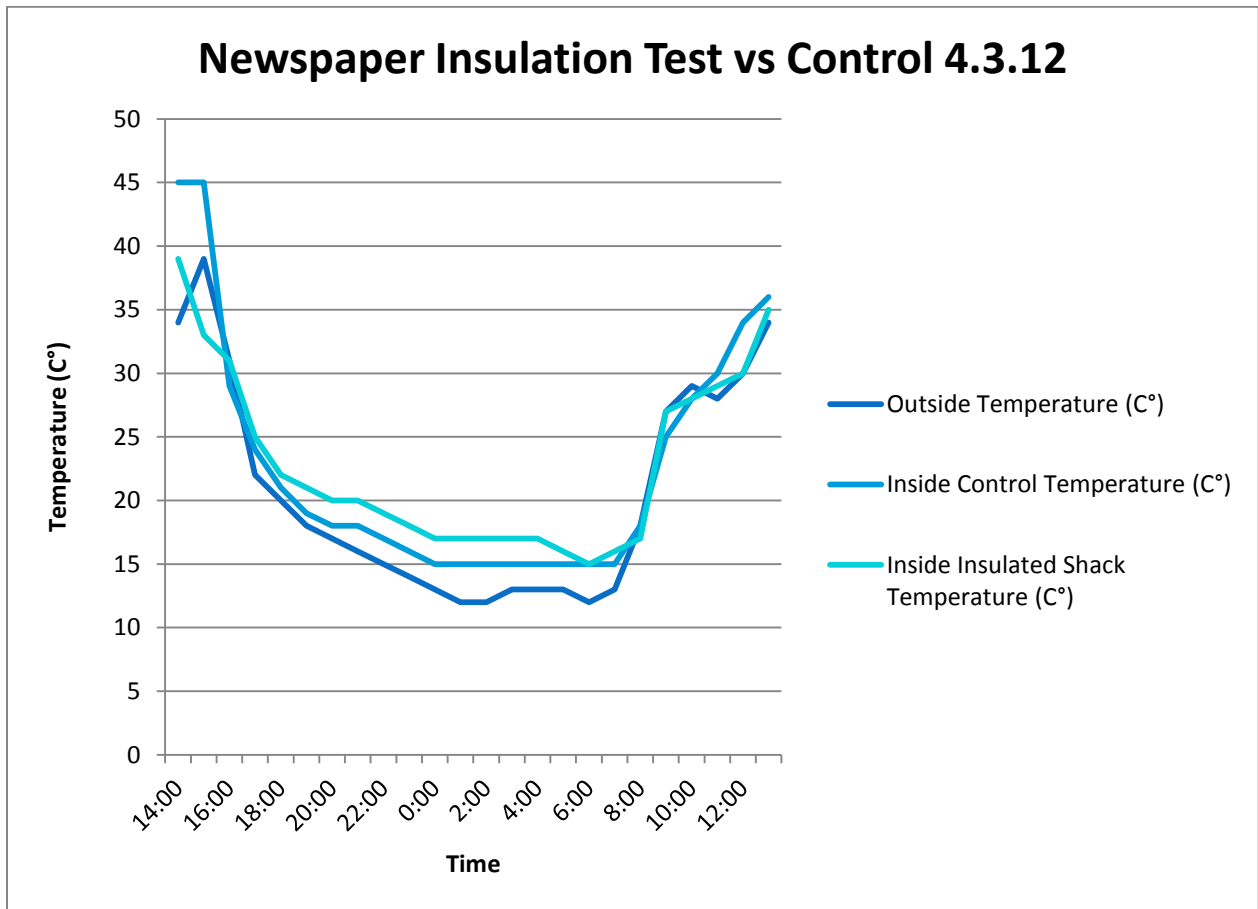

TABLE 6: 50 PERCENT MORE PAPER INSULATION TEST VS. CONTROL ON PUCCINI B&amp;B MID-LAWN 4.4.12

Time	Outside Temp (C°)	Inside Control Temp (C°)	Inside Insulated Shack Temp (C°)	Weather Condition	Direct Sunlight	Direct Sunlight	Degrees Difference Daytime: 10:00-13:00	Degrees Difference Nighttime: 18:00-10:00
14:00	37	40	39	Sunny	yes	yes		
15:00	25	27	28	Sunny	yes	yes		
16:00	30	28	32	Sunny	yes	no		
17:00	24	25	20	Sunny	no	no		
18:00	22	22	23	Sunset	no	no		1
19:00	19	20	22	Dark	no	no		2
20:00	18	19	21	Dark	no	no		2
21:00	17	19	20	Dark	no	no		1
22:00	15	18	19	Dark	no	no		1
23:00	14	17	18	Dark	no	no		1
00:00	12	16	18	Dark	no	no		2
1:00	12	16	17	Dark	no	no		1
2:00	14	15	16	Dark	no	no		1
3:00	14	14	15	Dark	no	no		1
4:00	13	14	15	Dark	no	no		1
5:00	10	13	14	Dark	no	no		1
6:00	10	13	14	Sunrise	no	no		1
7:00	11	14	15	Sunrise	no	no		1
8:00	21	17	19	Sunny	partly	partly		2
9:00	21	27	27	Sunny	yes	partly		0
10:00	27	27	27	Sunny	yes	yes	0	
11:00	28	31	30	Sunny	yes	yes	1	
12:00	28	36	33	Sunny	yes	yes	3	
13:00	29	36	34	Sunny	yes	yes	2	
						<b>Average Degree Difference</b>	1.5	1.1875

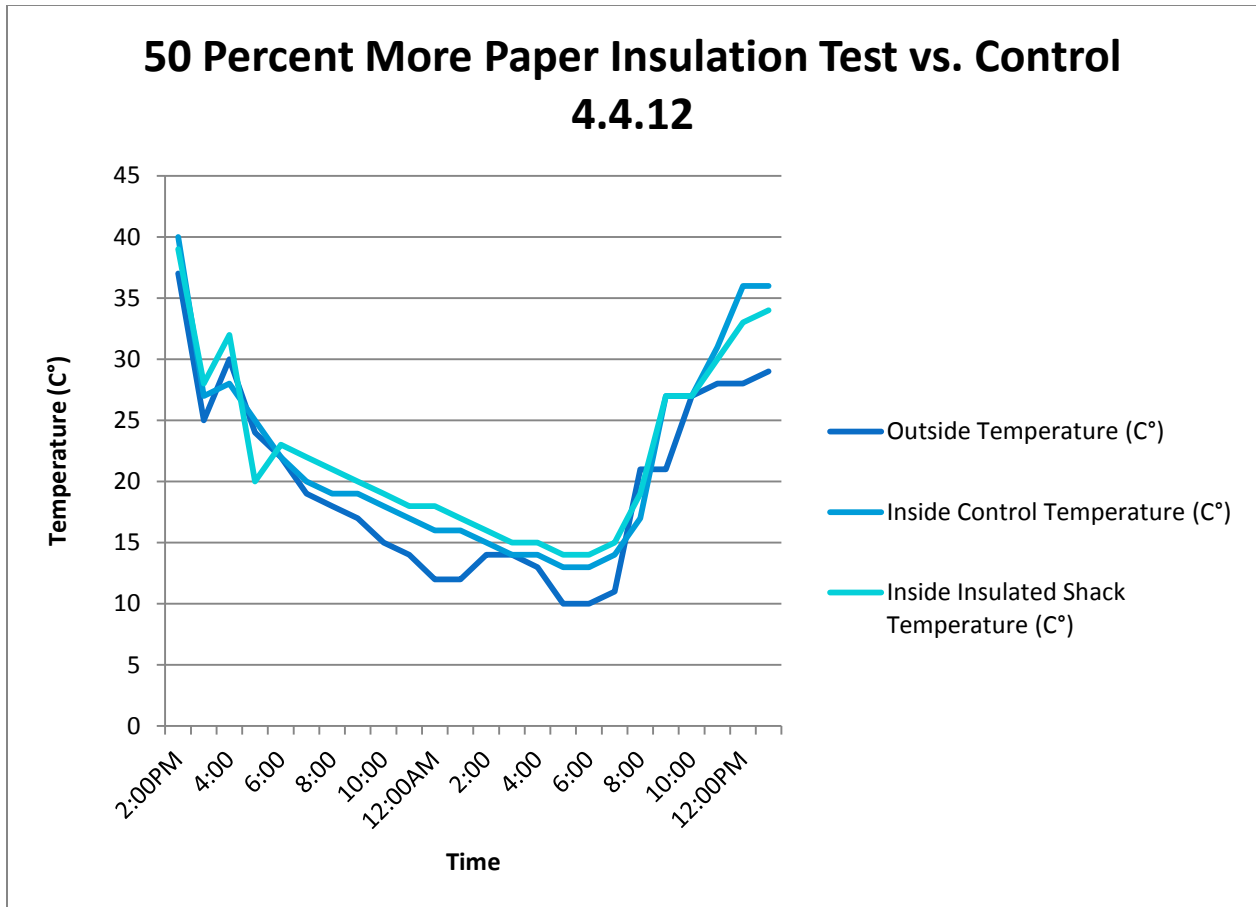

TABLE 7: 50 PERCENT LESS PAPER INSULATION TEST VS. CONTROL ON PUCCINI B&amp;B MID-LAWN 4.10.12

Time	Outside Temp (C°)	Inside Control Temp (C°)	Inside Insulated Shack Temp (C°)	Weather Condition	Direct Sunlight	Direct Sunlight	Degrees Difference Daytime: 10:00-13:00	Degrees Difference Nighttime: 18:00-10:00
14:00	28	35	28	Sunny	yes	yes		
15:00	27	29	27	Cloudy	no	no		
16:00	25	26	24	Cloudy	no	no		
17:00	17	22	21	Raining	no	no		
18:00	17	20	19	sunset	no	no		-1
19:00	17	19	19	Dark	no	no		0
20:00	17	19	19	Dark	no	no		0
21:00	16	17	18	Dark	no	no		1
22:00	15	18	17	Dark	no	no		-1
23:00	15	17	16	Dark	no	no		-1
00:00	12	17	16	Dark	no	no		-1
1:00	13	16	16	Dark	no	no		0
2:00	12	16	16	Dark	no	no		0
3:00	12	15	16	Dark	no	no		1
4:00	11	15	15	Dark	no	no		0
5:00	12	16	15	Dark	no	no		-1
6:00	12	15	15	Sunrise	no	no		0
7:00	13	16	15	Sunrise	no	no		-1
8:00	23	18	17	Sunny	no	no		-1
9:00	16	17	18	Sunny	yes	yes		1
10:00	30	32	29	Sunny	yes	yes	3	
11:00	32	36	32	Sunny	yes	yes	4	
12:00	32	41	36	Sunny	yes	yes	5	
13:00	32	42	39	Sunny	yes	yes	3	
						<b>Average Degree Difference</b>	3.75	-0.25



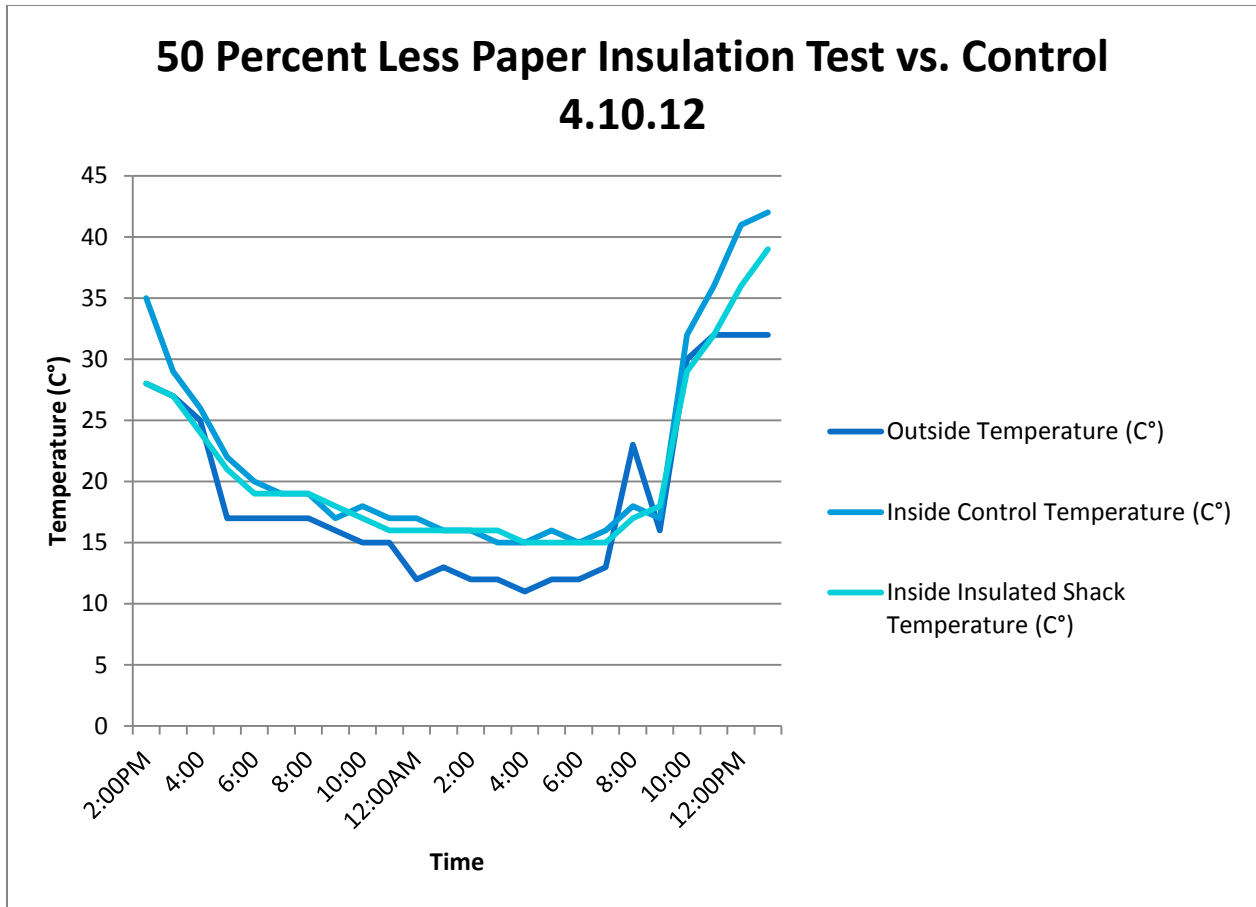

TABLE 8: 50 PERCENT LESS PAPER INSULATION TEST VS. CONTROL ON PUCCINI B&amp;B MID-LAWN 4.24.12

Time	Outside Temp (C°)	Inside Control Temp (C°)	Inside Insulated Shack Temp (C°)	Weather Condition	Direct Sunlight	Direct Sunlight	Degrees Difference Daytime: 10:00-13:00	Degrees Difference Nighttime: 18:00-10:00
14:00	28	29	30	cloudy	yes	yes		
15:00	25	27	28	cloudy	no	no		
16:00	24	25	26	cloudy	no	no		
17:00	22	23	24	cloudy	no	no		
18:00	19	20	21	sunset	no	no		1
19:00	17	19	20	dark	no	no		1
20:00	18	19	20	dark	no	no		1
21:00	18	18	20	dark	no	no		2
22:00	16	18	19	dark	no	no		1
23:00	15	17	19	dark	no	no		2
00:00	16	16	18	dark	no	no		2
1:00	15	16	18	dark	no	no		2
2:00	13	15	17	dark	no	no		2
3:00	13	15	17	dark	no	no		2
4:00	14	15	16	dark	no	no		1
5:00	14	15	17	dark	no	no		2
6:00	15	15	16	dark	no	no		1
7:00	16	16	17	sunrise	no	no		1
8:00	19	19	19	cloudy	no	no		0
9:00	25	22	24	sunny	no	yes		2
10:00	28	30	28	sunny	yes	yes	2	
11:00	29	32	30	sunny	yes	yes	2	
12:00	30	35	31	sunny	yes	yes	4	
13:00	32	40	33	sunny	yes	yes	7	
						Average Degree Difference	3.75	1.4375

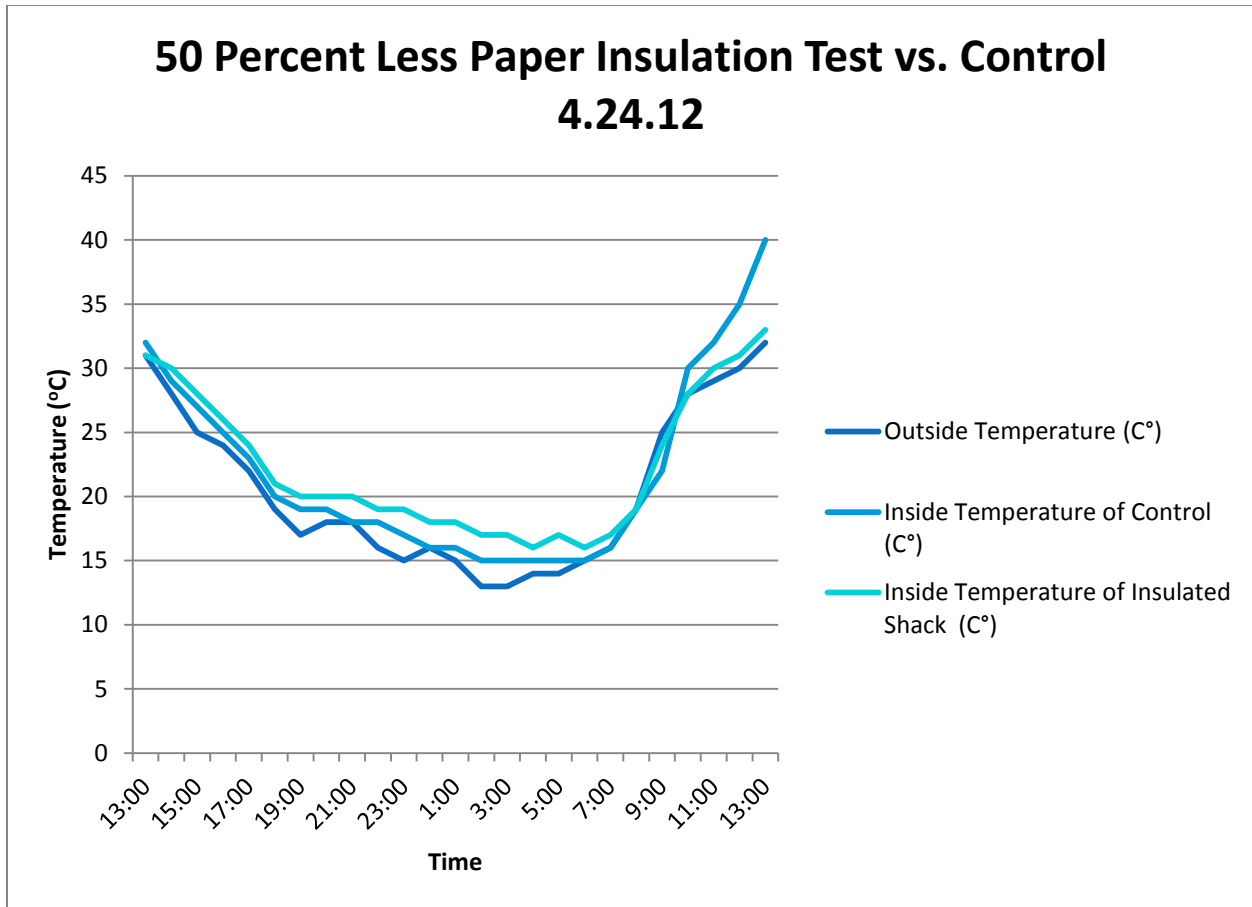
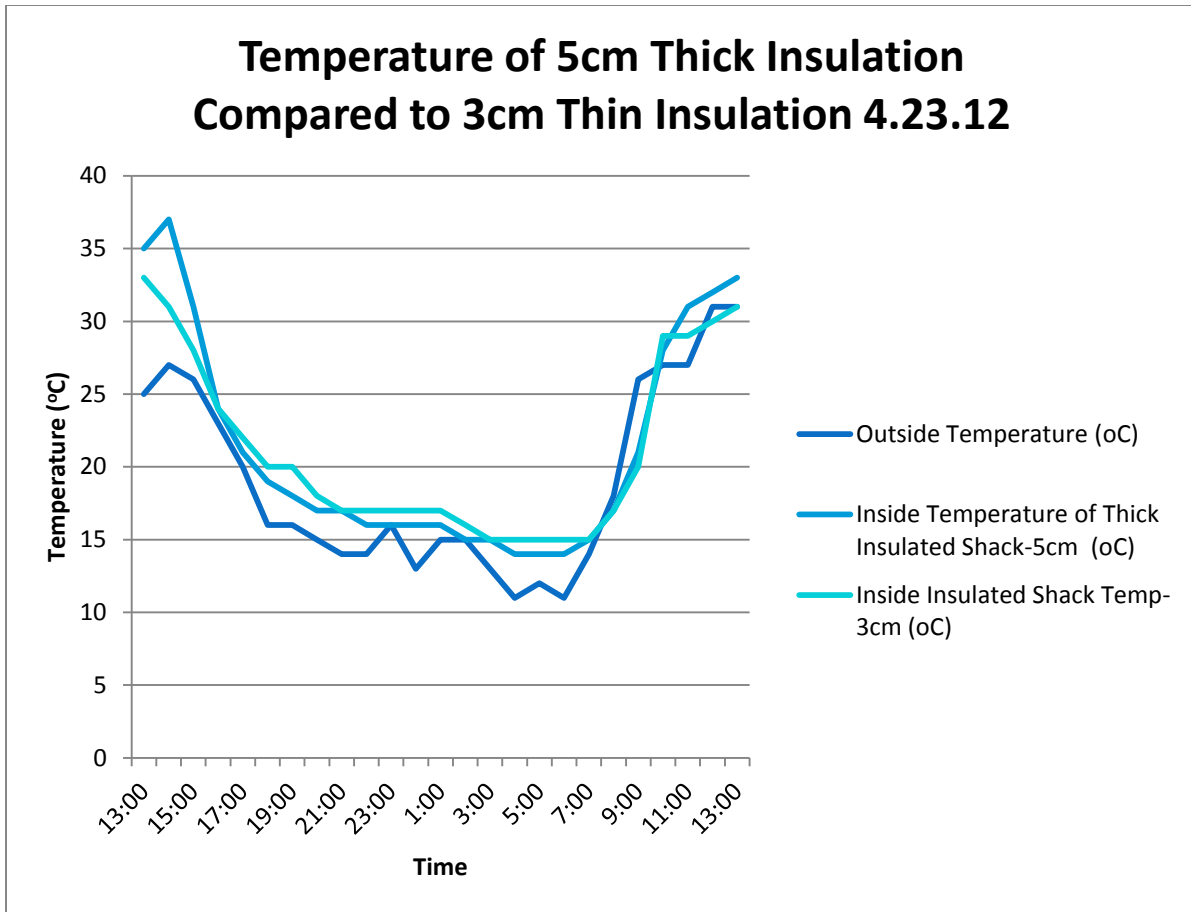

TABLE 9: TEMPERATURE OF 5CM THICK INSULATION COMPARED TO 3CM THIN INSULATION TEST ON PUCCINI MID-LAWN 4.23.12

Time	Outside Temp (C°)	Inside Control Temp (C°)	Inside Insulated Shack Temp (C°)	Weather Condition	Direct Sunlight	Direct Sunlight	Degrees Difference Daytime: 10:00-13:00	Degrees Difference Nighttime: 18:00-10:00
14:00	27	37	31	sunny	no	no		
15:00	26	31	28	sunny	no	no		
16:00	23	24	24	sunny	no	no		
17:00	20	21	22	sunny	no	no		
18:00	16	19	20	sunset	no	no		0
19:00	16	18	20	dark	no	no		1
20:00	15	17	18	dark	no	no		1
21:00	14	17	17	dark	no	no		2
22:00	14	16	17	dark	no	no		1
23:00	16	16	17	dark	no	no		0
00:00	13	16	17	dark	no	no		1
1:00	15	16	17	dark	no	no		1
2:00	15	15	16	dark	no	no		1
3:00	13	15	15	dark	no	no		1
4:00	11	14	15	dark	no	no		1
5:00	12	14	15	dark	no	no		0
6:00	11	14	15	dark	no	no		1
7:00	14	15	15	sunrise	no	no		1
8:00	18	17	17	partly sunny	no	no		1
9:00	26	21	20	partly cloudy	no	yes		0
10:00	27	28	29	partly cloudy	yes	yes	-1	
11:00	27	31	29	partly cloudy	yes	yes	2	
12:00	31	32	30	partly cloudy	yes	yes	2	
13:00	31	33	31	partly cloudy	yes	yes	2	
						Average Degree Difference	1.25	0.666667



## APPENDIX H: FIRE TESTING RESULTS

<b>Mixture</b>	<b>Ignition time after 10 sec</b>	<b>Flame Life* (sec)</b>	<b>Smoke Danger**</b>
<b>Standard</b>	<b>Yes</b>	<b>7.1</b>	<b>4</b>
<b>Newspaper</b>	<b>Yes</b>	<b>5.4</b>	<b>1</b>
<b>50%+</b>	<b>No</b>	<b>5.2</b>	<b>3</b>
<b>50%-</b>	<b>Yes</b>	<b>3.5</b>	<b>5</b>
<b>50%- Salt</b>	<b>Yes</b>	<b>6</b>	<b>2</b>
<p>*- The amount of time the insulation sustained fire after direct exposure to a flame for 40 seconds</p> <p>**- On a scale of one to four: 1- indicates the highest smoke danger, 5- indicates the least</p>			

## APPENDIX I: INSULATION TESTING RANKING SHEETS

Insulation Type	Thermal Resistivity	Insulating Average
	5= most resistant	
Standard	4	4
+50% Paper	3	3
-50% Paper	5	5
Standard Newspaper	2	2

Insulation Type	Ease of Production			Cost	Production Average
	Days to Soak	Stirring	Days to Dry		
	5= least	5= easy	5= least	5= min cost	
Standard	5	4	5	5	4.75
+50% Paper	5	3	5	5	4.5
-50% Paper	5	5	5	5	5
Standard Newspaper	4	4	4	5	4.25

Insulation Type	Health Hazard	Fire Resistance		Safety Average
		Smoke Produced	Ignition Time	
	5= least	5 = longest	5= shortest	
Standard	4	4	2	3.33
+50% Paper	3	5	4	4
-50% Paper	5	4	5	4.66
Standard Newspaper	2	4	3	3

Insulation Type	Community Preference		Aesthetic Average
	Aesthetic Appeal	Personal Preference	
	5= appealing	5= best	
Standard	3	4	3.5
+50% Paper	3	3	3
-50% Paper	3	5	4
Standard Newspaper	3	2	2.5

Insulation Type	Total Insulation Score
Standard	3.895
+50% Paper	3.625
-50% Paper	4.665
Standard Newspaper	2.9375



APPENDIX J: INSULATION INFORMATION HANDOUT



**THE PAPER  
INSULATION  
PROJECT**



**MAKING INSULATION  
FROM WASTE  
MATERIALS.**



Tel: 061-305892  
 Fax: 061-307205  
 Cell: 081 3452195  
 E-mail: office@msr.org.na



Oinsulator ei ohaikwafele okukaleka obashu yoye ikale mwatalala nawa efimbo lomutenya no kukaleka mwapupyala pefimbo luutalala. Oiyoye yo MSR otaidulu okukwafela mokuninga no kulandifa iilongomwa ei. Ohatu ningi omapekapeko oilongomwa dingi yo insulator notwapumwa ekwafelo loye! Otoindilwa ekwafelo loye opo umane okuhadeka omavalulo atulwako.

These insulation sheets help to keep your kambashu cooler during the day and warmer in the winter. MSR members can help make and sell these sheets. We are researching the best insulation and need your help! Please complete the attached survey.



## APPENDIX K: INSULATION SURVEY FOR MSR MEMBERS

---

Which insulation do you think is best?\*

Oinsurator ilipi uwete oyo dingi?

1    2    3

Which thickness do you prefer?

Oshapuumba okukala shiifike peni munene?

Thick (Shadeka)                      Thin (shinini)

Do you like how it looks?

Uhole mefano omu tashimonika?

Yes (Eheno)    No (ahawe)

What color would you like it to be?

Oluvala lilipi wahala shikale?

\_\_\_\_\_

Would you use it?

Otoshilongifa ngaho?

Yes (Eheno)    No (ahawe)

Does your roof leak?

Oipeleki yoye ohaidiya omeva pombada?

Yes (Eheno)    No (ahawe)

Would spend money to mend the leaks?

Otohale okulongifa oiimaliwa okuufitika eembululu?

Yes (Eheno)    No (ahawe)

Are you worried about fires in your kambashu?

Ouna umbada kombinga yomundilo mokabashu koye?

Yes (Eheno)    No (ahawe)

Would you be interested in safer ways to light your home?

Ouna ehalo mokutema meumbo loye momukalo waamenwa?

Yes (Eheno)    No (ahawe)

What would you pay AT MOST per sheet of insulation?

Ingapi todulu okufuta oshipambu shimwe sho insulator?

N\$2    N\$3    N\$4    N\$5    more (ile shidulifepo)

Would you be interested in participating in this project?

Ouna ehalo okukufa ombinga mopoloyeka ei?

Yes (Eheno)    No (ahawe)

\*Insulation was labeled; 1= 50% less paper, 2= standard, 3= 50% more paper

## APPENDIX L: COMMUNITY INTERVIEW SUMMARIES

---

### Michael; male, about 30 yrs

- Lived in Katutura/Havana his whole life
- Description of temperature inside: suffering.
- Is it uncomfortable? Yes.
- When asked if he knew what insulation was, he said yes. In further discussion it was unclear if he did know, but he does think that it will help regulate temperatures
- When asked about safety, he was worried about fires, but said that most fires happen because people are careless, so the insulation would not make it worse.
- When asked how much he spends on wood, paraffin, kerosene or electricity, he said that he uses wood, candles, paraffin, and kerosene and that it costs a lot. There is no electricity in Havana.
- He said that he would purchase an insulation material if we could show him it worked and if it was cheap.
- He said that he was very concerned about shack fires because the fire brigade is very slow, and there are no streets or addresses, so it is hard for them to get there in time.
- He said that there are leaks in his roof that he fixes with cloth.

### Woman; about 40 yrs

- She is from the Northern Region and moved to Havana about 20 years ago.
- When asked to describe the indoor temperature, she said that sometimes it can get very hot, but it is usually not extreme. It does not get too cold at night. They do not do anything to fix this.
- She did not know what insulation is, but after Pius explained it to her, she said that she thinks it's really needed and that it would definitely help.
- She said that wood is very expensive so she spends a lot of money on that to heat and cook.
- She would be interested in insulation as long as it is affordable for everyone.
- She uses candles for light and firewood outside to cook and paraffin inside to cook.
- She said that she is worried about fires and that one happened not too far away last week.
- To protect her family and kambashu from fire, she keeps the candles away from children and leaves them in the adults' rooms at night
- She said that rain leaks through her roof and they just put buckets underneath it to catch the water where it drips.

### 3 Women; 30-40 yrs at a hair salon

- They said that it is very hot and uncomfortable and they do not do anything to fix it.
- They think that insulation will help regulate temperature and they would want it; they described insulation before we suggested this (when asked about fixing the extreme temperatures).
- They do not think that insulation would make fires worse and they would purchase insulation if it looked similar to the paper blocks.
- They said they spend a LOT to heat and cook and that they would purchase a cheap insulation (suggested about \$2)

- They use paraffin, wood, and candles to cook and for lighting.
- They said that they would prefer the benefits of insulation over the safety of shack fires.
- Lastly, they said that rain leaks through the roof a little, but it comes through the walls more and that they fix it by moving items to one side of the room or the other depending on where the water is coming in.

#### **Male; 25ish yrs**

- He has lived in Havana for 5 years.
- He described the temperature as being too hot during the day, but not too cold at night. Rather than fix this, he said that they just have to live with it.
- He did not know what insulation is, but after Pius explained it to him, he said that yes, it would be helpful.
- He said that he would be interested in buying it as long as it is cheap.
- He said that fires happen a lot but it is not a big problem to him because he keeps his home safe. He said that most fires happen because people forget to light off the candle, so installing insulation will not worsen the incidences of fires.
- He said that there are no leaks in his roof.

#### **Hierdo; Male; 25-30 yrs**

- He has lived in Katutura for 5 years, but lived in a kambashu for only one. He migrated from the north because of starvation and poverty.
- He said that it is very hot and unbearable in the shacks; you do not want to go inside in the afternoon because it is so hot.
- He understood what insulation is and thinks that it would be a very good idea, it would work, and it would be safe.
- He said that wood is expensive because it is so scarce
- He would purchase insulation, and thinks his friends and family would too if it was very cheap
- He uses a paraffin stove, candles and wood; he says it is expensive.
- He says that he is concerned about shack fires, but it usually happens because people are careless.
- He said that leaks are a big problem especially on sloped land.

#### **Vicki; Female, about 25 yrs**

- She has lived in Katutura for 3 years.
- She was originally from the Northern part of Namibia.
- She said that it gets hot inside during the summer: "yes, very hot."
- She also said that it gets cold at night.
- She doesn't do anything to cool her home during the summer months.
- She said that she didn't know what insulation was, then Pius explained what it was and she understood.
- When asked if she thought insulation would help, she said yes.
- When asked if she would purchase it, she said she would if it was very cheap.

- She said she was concerned about shack fires: Yes, a lot of kambashus burn. “This one did” (she points to one behind her).
- She said that she did not think the insulation would catch fire if people kept the fires safe.
- She said that water did leak into the shack.
- She does not do anything to mend the leaks. She just uses buckets to catch the water.
- The woman also told us that we must help.

**Male; 20-30 years old; brick house with corrugated iron roof**

- He said that it does get hot inside during the summer.
- He said that it gets hotter inside than outside and you can feel it when you go inside.
- He said that it gets cold in the winter; too cold.
- He says that you would need to be wearing a jacket during the winter months and that they use blankets to keep warm. “You can’t wear what you are wearing now, you would put on a jacket.”
- They have electricity in their home, but do not use it to heat the home in the winter because it is too expensive. He says that they spend N\$50 a month on electricity and it is too much.
- They are not currently using insulation.
- He said they there were not house fires in the neighborhood.
- He chose not to answer the question: Does water leak inside when it rains?

**Male; 25-30 years old; corrugated metal home**

- He has been living in Katutura for 10 years.
- He said it does get very hot during the summer.
- And agreed that it gets cold at night and during the winter.
- When if he does anything to cool or heat the home, he said that he didn’t do anything. He just uses blankets during the winter to keep warm.
- He said that he does know what insulation is.
- When asked if he thought insulation would help, He said that it would because it “keeps the heat out.”
- He said there were a lot of fires.
- When asked if he thought that insulation would increase incidence of fire, he said no because the fires are caused by careless people.
- When asked if water leaks into the home, he said that the problem was not the roof, but that the water comes in through the ground and they have to move things inside from one side to another when the water comes in.

**Female; 16 years old; brick house with corrugated iron roof**

- She has been living in Katutura for 16 years (her whole life).
- She said that does not get too hot inside the home.
- However, she said it does get cold.
- She does know what insulation is but does not have it in her house.
- She said that she has not seen a fire occur in the neighborhood.
- When asked if water comes leaks in through the roof, she said that just a little bit comes in and they haven’t tried to mend it.

**Female; 20-30 years old; corrugated metal house**

- She said that at this time of year (April) that it does get cold at night.
- She said that it gets too cold at night.
- To stay warm they just use blankets.
- She said that it gets too hot inside during the summer.
- She said she uses a fan in the summer to deal with the heat.
- She does know what insulation is.
- When asked she thought what a reasonable price for insulation would be, she answered that N\$20 per room would be a good price.
- She said that she did not think fires happened in the neighborhood.
- She said yes water comes inside when it rains and that she does not do anything to stop it from coming in.
- Her shack had large gaps where the sides were not connected to the frame.

**Female: 30-40 years; Corrugated metal house**

- She lived in Katutura for 5 years
- She built her house to get the water to slope off.
- She said it gets very hot inside her house during the summer. She said you can't sleep under a blanket, but also said it wasn't completely unbearable.
- She had no knowledge of what insulation is.
- She spends N\$400 monthly on electricity.
- If insulation was cheap she would buy it, even if it were made from paper.
- She specified that cheap is below N\$800 for the entire roof.
- She has no problem with water leakages and has no way to protect her house from shack fires.

**Male: 25-35 years; Corrugated house**

- He was from the northern region of Namibia and has only lived in Katutura for a year in his brother's house.
- He was not sure why his brother built the house the way it is.
- If he could improve one thing, He said it would be ventilation (whirlybirds).
- After a year he said it gets incredibly hot during the summer and is very uncomfortable.
- He throws water on the ground to let it vaporize and cool the house down.
- Does not know what insulation is, but thinks that a paper product is still safe.
- He spends N\$500-600 a month on electricity
- He would purchase a low cost insulation if it were below N \$1000 even if it were made of paper.
- He uses electricity on top of gas to cook.
- He has no issues with water leakages.

**Female: 20-30; Corrugated metal house**

- She is from the northern region who has lived in Katutura for two years.
- She would like more and better rooms in the house
- She stated that outside of summer, the temperature wasn't too bad but during the summer it is bad.
- She said everyone just sucks it up and doesn't do anything to fix it.
- She does know what insulation is and does think that it would regulate the temperature.
- She thinks it is safe and would purchase it even if it were made from paper.
- She said it must be cheap but said even up to \$N3000.
- She has no issue with water leakages.

**Male: 24; Corrugated house next to parents house**

- He has lived in Katutura his entire life and has a sloped roof to control rain.
- If he could improve his house, he would improve the roof.
- He said the temperatures get hot but he gets used to it and some years are worse than others are.
- He admitted that during hot summers it is uncomfortable.
- He opens the freezer door and lets cold air out regulate temperature.
- He does not know what insulation is but he does think it is safe, even if it were made of paper.
- He spends N\$2000 monthly on electricity for 8 people.
- He said he would purchase insulation even if it were made of paper for around N\$500.
- He has issues with water leakages because of holes in the roof. Holes get there when he hammered in nails and missed the wood stud.
- Stated he would love to test the insulation (so did one other friend with him).

APPENDIX M: PRELIMINARY MOLD DESIGN

---

The preliminary mold design included a four-sided polygon, with sloped sides.

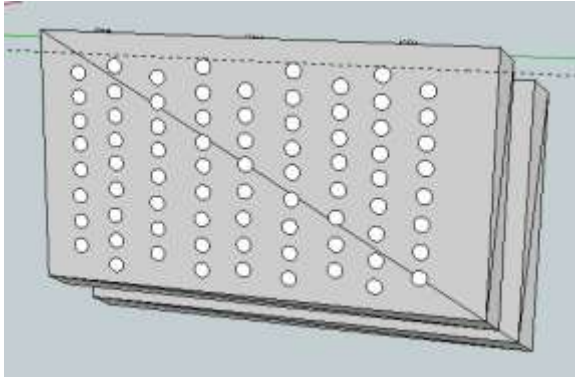

Top and bottom faces of the mold, slightly offset to create slants

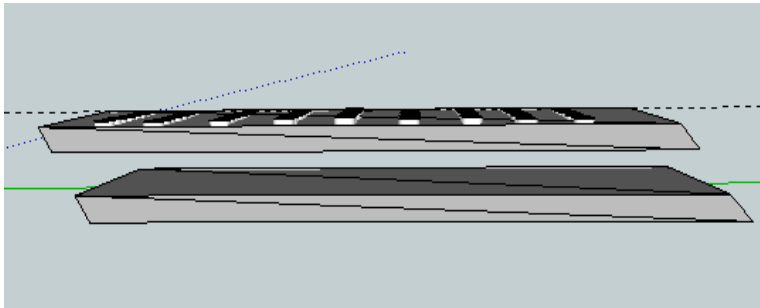

Slopes along the width of the two faces



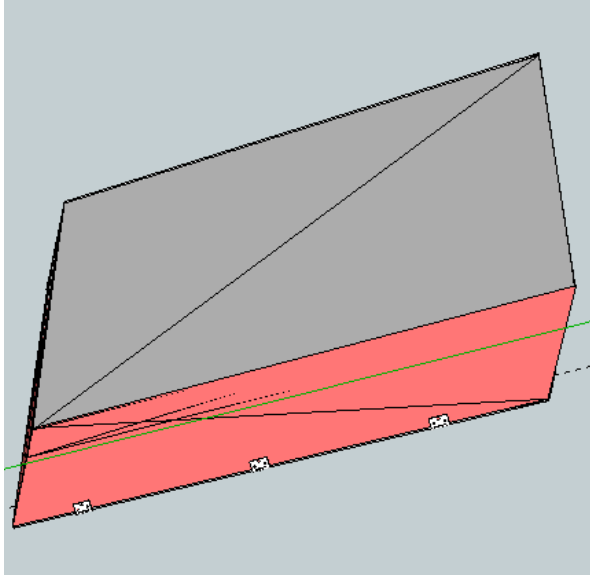

Bottom view of completed design with sloped faces. The bottom is solid to apply more pressure

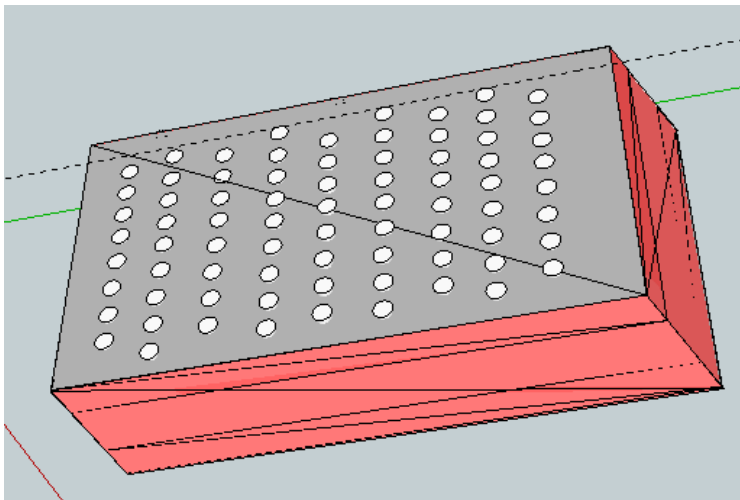

Top View of mold. Holes in the face to allow water to escape. Note sloped heights.

APPENDIX N: PROTOTYPE MOLD DESIGN

---

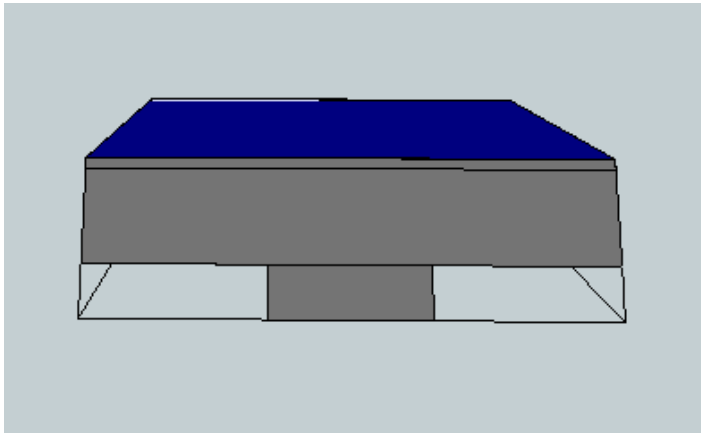

Front View: T Shape of the mold.

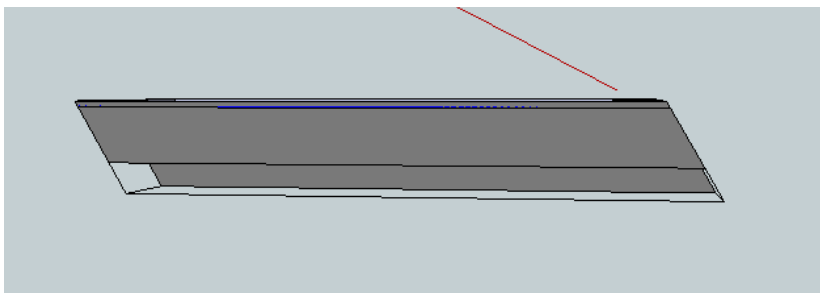

Side View: Sloped widths. Note indentations along entire length

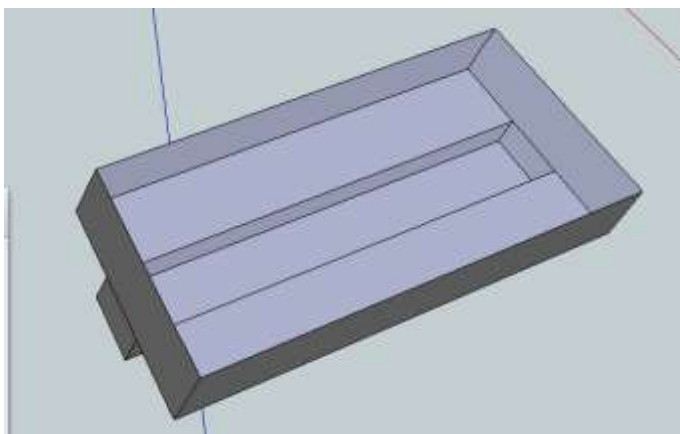

Inside View: Illustrates areas where paper pulp will be packed

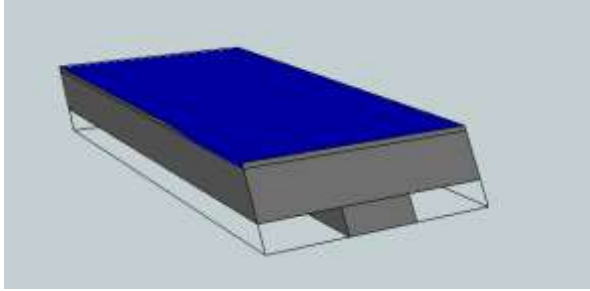

Completed Design. Top face (blue) is the movable face