



**WPI**

# A Stride Towards the Elimination of Consumer Waste:

Development of a Reusable Cup Machine

**Submitted by:**

Jehu De la Rosa  
Gregory Kashmanian  
Nicholas Kratovil  
Molly O'Connor  
Owen Smith

**Submitted to:**

Professor Calli  
Professor Wodin-Schwartz

April 7, 2020

*This report represents the work of four WPI undergraduate students submitted to the faculty as evidence of completion of a degree requirement. WPI routinely publishes these reports on its website without editorial or peer review.*

# Abstract

This project pursues an autonomous solution for reducing single use cup waste through a reusable cup sharing kiosk. A design concept suitable for this type of program must receive a dirty cup from a consumer and return a clean cup ready-for-use. Such a device must have washing, drying, storing, and dispensing capabilities. The design process consists of three main steps: brainstorming, analyzing, and comparing with a design matrix. The final product prioritizes compactness and simplicity of mechanical systems. It uses a carousel-like design to pre-rinse, deep cleanse, and air dry cups before dropping them into storage. Cups are dispensed using a two-step rack and pinion mechanism and reoriented for face-up consumer retrieval. Though significant progress was made in the implementation of the proposed design, there is still considerable work to be done to finish this prototype due to the interruption of the semester by the COVID-19 pandemic.

# Acknowledgements

We would like to gratefully acknowledge the following individuals for their contributions and guidance in the creation of this project and report:

Dr. Sarah Wodin-Schwartz, *Project Adviser*

Dr. Berk Calli, *Project Adviser*

Barbara Fuhrman, *WPI ME Dept.*

Dr. Fiona Levey, *WPI ME Dept.*

Dr. Stephen Kmiotek, *WPI ChE Dept.*

James Loiselle, *WPI Washburn Labs Staff*

# Table of Contents

<b>Abstract</b>	<b>1</b>
<b>Acknowledgements</b>	<b>2</b>
<b>Table of Contents</b>	<b>3</b>
<b>Figures and Tables</b>	<b>6</b>
Figures	6
Tables	9
<b>Chapter 1: Introduction</b>	<b>10</b>
<b>Chapter 2: Project Goals and Vision</b>	<b>12</b>
<b>Chapter 3: Background</b>	<b>14</b>
3.1. Environmental Need for Reusable Cup Program	14
3.2. Current Cup Programs	17
3.3. FDA Regulations	19
3.3.1 The Cleaning Process	20
3.3.2 Technical Specifications	21
3.4. State Machines	21
3.5. Controls for Mechatronic Systems	24
3.6. Stakeholder Analysis	30
<b>Chapter 4: Initial Design Process</b>	<b>33</b>
4.1. Core Design Attributes and Criteria	33
4.2. Initial Cleaning System Designs, First Round	34
4.2.1 Design 1: Descending Chamber and Rail Design	35
4.2.2 Design 2: Translating Batch Cleaner V1	37
4.2.3 Design 3: Bar Glass Rinser V1	37
4.2.4 Design 4: Actuated Nozzle Frame	38
4.2.5 Design 5: Belt-Driven Corner Function Design	39
4.2.6 Round 1 Results	40
4.3. Initial Cleaning System Designs, Second Round	42
4.3.1 Design 1: Descending Chamber and Pneumatics Design	42
4.3.2 Design 2: Translating Batch Cleaner V2	44
4.3.3 Design 3: Bar Glass Rinser V2	45
4.3.4 Design 4: Sequential Function Rotation and Hood Actuation Design	46

	4
4.3.5 Design 5: Multifunctional Rotation and Hood Actuation Design	48
4.3.6 Round 2 Results	48
4.4. Design of Supporting Subsystems and Structure	50
<b>Chapter 5: Finalized Overall System Design</b>	<b>54</b>
5.1 Cleaning Subsystem	54
5.1.1 General Description	54
5.1.2 Actuator Selection	56
5.1.3 Cycle Length Determination	58
5.1.4 Fluid & Air Delivery	62
5.1.5 Electrical Controllers	65
5.1.6 Software Engineering	67
5.2 Storage/Dispensing Subsystem	68
5.3 Supporting Structure	71
<b>Chapter 6: Testing, Prototyping, and Assembly</b>	<b>72</b>
6.1 Testing	72
6.1.1 Dispensing System Cup Flip Test	72
6.1.2 Nozzle Pressure and Distance Testing	73
6.2 Prototyping and Assembly	73
6.3 Incomplete Testing and Assembly	77
<b>Chapter 7: Conclusions &amp; Recommendations</b>	<b>78</b>
7.1 Recommendations	78
7.1.1 System Scale	78
7.1.2 Cleaning Agent Incorporation	78
7.1.3 Cycle Length Determination	79
7.1.4 Cup Cleaning Queue	79
7.1.5 Cup Storage	79
7.1.6 Cup Orientation	79
7.1.7 Air System Testing	80
7.1.8 System Application	80
7.1.9 System Input and Output Interface	80
7.2 Reflections on the Design and Manufacturing Process	81
7.3 Unfinished Work	82
7.4 Conclusions	82
<b>References</b>	<b>84</b>

<b>Appendix A - Design criteria for our initial design process with explanation and weighting.</b>	<b>88</b>
<b>Appendix B - Head Loss Calculation Process</b>	<b>90</b>
<b>Appendix C - Matlab Stepper Motor Torque Calculations</b>	<b>95</b>
<b>Appendix D - Github Gist Links for Code Files</b>	<b>97</b>
Python	97
Arduino	97
<b>Appendix E - Bean Counter Interview</b>	<b>98</b>
<b>Appendix F - WPI Food Services Employee</b>	<b>100</b>
<b>Appendix G - User Interface Screens</b>	<b>102</b>

# Figures and Tables

## Figures

Figure 1: <i>Flowchart for cup-share program in a coffee shop scenario</i>	11
Figure 2: <i>Climate change is the world's most prominent threat</i>	15
Figure 3: <i>Production energy comparison for reusable and disposable cups</i>	16
Figure 4: <i>Break even comparison for reusable and disposable cups</i>	16
Figure 5: <i>End of life for disposable cups</i>	17
Figure 6: <i>Vessel Works reusable cups</i>	18
Figure 7: <i>Mugshare reusable cup</i>	19
Figure 8: <i>State machine diagram of vending machine</i>	22
Figure 9: <i>Non-deterministic state diagram</i>	23
Figure 10: <i>General dynamic system model</i>	25
Figure 11: <i>Open-loop feedback (a) and closed-loop feedback (b)</i>	26
Figure 12: <i>A closed-loop control model</i>	27
Figure 13: <i>Visual representation of transition logic</i>	27
Figure 14: <i>Pin layout of the Arduino UNO</i>	29
Figure 15: <i>Raspberry Pi pin layout</i>	30
Figure 16: <i>The Bean Counter in Worcester, MA</i>	31
Figure 17: <i>The complete design matrix</i>	34
Figure 18: <i>General layout for the descending chamber and rail design</i>	35
Figure 19: <i>Drawing for the concept of the clamshell</i>	36
Figure 20: <i>Cleaning and drying process of the cup with the descending chamber and rail design</i>	36
Figure 21: <i>Translating Batch Cleaner</i>	37

Figure 22: <i>Bar Glass Rinser</i>	38
Figure 23: <i>The cup is cleaned by actuating the metal frame into and around the cup. The cup is held by a gripper</i>	39
Figure 24: <i>Belt-Driven Corner Function Design</i>	40
Figure 25: <i>Scoring of the first round of designs using an old design matrix</i>	41
Figure 26: <i>General layout for the descending chamber and pneumatics design</i>	43
Figure 27: <i>The clamshell design using the bar glass cleaner</i>	43
Figure 28: <i>Multiple consecutive bar glass cleaners or a 2-by-2 arrangement of bar glass cleaners for batch cleaning</i>	44
Figure 29: <i>Translating Batch Cleaner V2</i>	45
Figure 30: <i>Bar Glass Rinser V2</i>	46
Figure 31: <i>Overhead view of carousel</i>	47
Figure 32: <i>Cleaning and drying partitions</i>	47
Figure 33: <i>Multifunctional Rotation and Hood Actuation Design</i>	48
Figure 34: <i>Design matrix showing results for the second round of designs</i>	49
Figure 35: <i>Chosen model and render based on Design 5</i>	50
Figure 36: <i>Initial design drawing for Dispensing System V1</i>	51
Figure 37: <i>Dispensing System V2</i>	52
Figure 38: <i>Demonstration of the cup hitting a ledge and flipping</i>	52
Figure 39: <i>Cleaning Subsystem, consisting of: Top (A), Upper Nozzle Pocket (B), Carousel (C), Mesh Layer (D), Lower Nozzle Pocket (E), Drainage Basin (F) and Storage (G)</i>	55
Figure 40: <i>Carousel Cycle Stages (Seen from below)</i>	56
Figure 41: <i>The central axis</i>	57
Figure 42: <i>General parameters used for the meshing (left) and mesh controls applied specifically to the carousel and lower nozzle mount (right)</i>	59
Figure 43: <i>Steady state SOLIDWORKS thermal analysis with acrylic components (except for aluminum center rod) and 105°F water temperature</i>	59



Figure 44: <i>A plot of the lumped sum approximation for the machine</i>	61
Figure 45: <i>Schematic of the piping for the machine</i>	63
Figure 46: <i>Pressurized air delivery schematic</i>	65
Figure 47: <i>Overall system schematic</i>	66
Figure 48: <i>A description of the high level flow of the system's GUI</i>	67
Figure 49: <i>The home screen of the user application</i>	68
Figure 50: <i>Dispensing subsystem</i>	69
Figure 51: <i>Dispensing rack and pinion system</i>	69
Figure 52: <i>The assembly of the storage system with the dispensing system</i>	70
Figure 53: <i>Complete assembly of the cleaning system and storage/dispensing system</i>	71
Figure 54: <i>Testing for flipping of the cup after dispensing</i>	72
Figure 55: <i>Basic testing of the water pressure regulator with one of the cups</i>	73
Figure 56: <i>Cleaning Subsystem, consisting of: Bearings (A), Stepper Motor (B), Belt (C), Top (D), Upper Nozzle Pocket (E), Carousel (F), Mesh Layer (G), Lower Nozzle Pocket (H), Drainage Basin and Storage (I), Drainage Basin (J), and Central Rod (K)</i>	74
Figure 57: <i>Storage/dispensing subsystem, consisting of: Storage and Chute (A), Upper Gripper (B), Upper and Lower Shelves (C), Bottom Door (D), and the Flipping Mechanism (E)</i>	75
Figure 58: <i>Storage/dispensing subsystem, consisting of: Servo (F), Rack and Pinion (G), and Exit Chamber (H)</i>	76
Figure 59: <i>Piping design diagram with each of the three zones shown. Red marks Zone 1, orange marks zone 2, and zone 3 is all piping after the second set of tees and reducers</i>	90
Figure 60: <i>Equivalent lengths of fittings</i>	93

## Tables

Table 1: Chlorine Solutions	21
Table 2: Design criteria explanation for initial design	88
Table 3: Volumetric flow rate at each zone	91
Table 4: Reynolds number at each zone	91
Table 5: Relative roughness at each zone	92
Table 6: Darcy friction factor at each zone	92
Table 7: Best and worst case scenario at each zone	93
Table 8: Volumetric flow rate at each zone	94

## Chapter 1: Introduction

In today's convenience culture, it is becoming an increasingly common trend for consumers to purchase take-away drinks such as coffee, fountain sodas, fountain water, slushies, smoothies, teas, and juices. Fountain sodas alone have a projected compounded annual revenue growth rate of 2.4% from 2019 to 2024 (MarketWatch, 2019). Restaurants, shops, and facilities on college campuses all tend to offer these types of beverages to-go, and no matter the source there is one commonality: the vendor uses a single-use, disposable paper, plastic, or styrofoam cup for to-go orders. Many businesses allow customers to bring their own reusable containers to be filled, and some even offer discounts for customers that do, though this tends to be a grossly underutilized option. Under 2% of Starbucks customers bring a reusable cup despite a possible 10-cent discount (Morales, 2016).

Currently, a garbage patch three times the size of France dwells in the ocean between California and Japan (Liu, 2018). The Great Pacific Garbage Patch, a result of swirling ocean currents picking up discarded land waste and fishing waste, is composed of debris ranging from fishing nets to microplastics that are less than 5 millimeters in size. This garbage, 54% of which comes from land-based activities, can kill marine wildlife, be ingested by marine wildlife, or can introduce non-native species to different areas. Furthermore, degradation of plastics by the sun not only causes it to break down into smaller pieces, but may also cause leaching of harmful chemicals (National Geographic, 2019). Moreover, production of these single-use cups requires the continual burning of fossil fuels. Single-use cups are an environmental issue both during and after their production. Even on a local level, improperly discarded cups litter the streets of Worcester and many other cities like it. Again, this litter may be mistakenly consumed by animals or could end up in the ocean as the plastic degrades and finds its way into the sewer system.

The solution, at first, seems quite simple: have people use reusable cups to create less waste. As reasonable as it sounds, this may be difficult due to single-use packaging being so commonplace and being so deeply rooted in our culture. However, an automated machine will ideally help increase convenience and provide financial benefits to incentivize adoption of reusable cups. The intent of the machine is to dispense, collect, clean, and stock reusable cups; it will ideally be a vending-machine sized unit that will be conveniently located near places that offer to-go beverages such as coffee shops or fast-food restaurants. The idea is that a user could grab a cup, fill it with their drink, and use the cup for the day. When they finish and return to purchase another drink, the user could drop off a dirty cup and receive a clean one that they can fill. See Figure 1 for an example of the intended cup-share program.

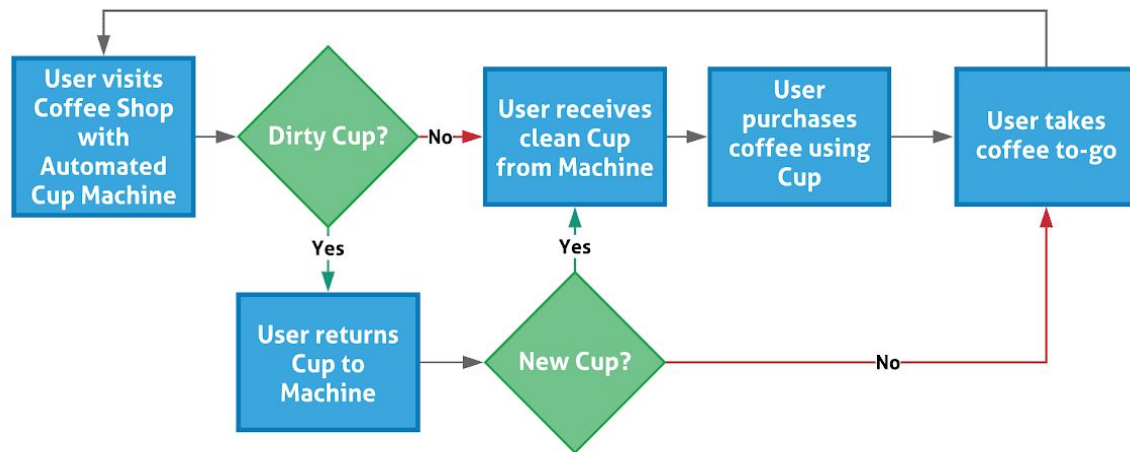

**Figure 1:** *Flowchart for cup-share program in a coffee shop scenario*

To incentivize adoption of the program, businesses could potentially offer discounts or promotions for customers signing up, such as getting their first fill free with a reusable cup. Financially, the consumer is able to save money and the business can be more environmentally friendly and spend less money on packaging that will be thrown away by the consumer. The creation of this machine and the development of the associated cup-share program will ideally help reduce waste as well as offer financial benefits to both the consumer and the businesses that use it. Most importantly, it has the potential to make a substantial environmental impact and help in the fight against pollution and climate change.

## Chapter 2: Project Goals and Vision

The project's goal is to build a functioning prototype of a machine that is used to:

- Dispense reusable plastic cups given a user request
- Collect dirty plastic cups when a user places it in the machine
- Clean plastic cups in accordance with FDA standards
- Store a plastic cup inside until a user requests that it is dispensed.

This is accomplished by breaking the machine down into distinct sub-systems such as:

- A system to dispense clean cups and collect dirty cups.
- A transportation system to move the cup inside the machine and to/from the dispenser/collector.
- A cleaning system that is used to clean the cups.
- A storage system used to store cups that have been cleaned and are ready to be dispensed.
- A human-machine interface that allows the user to give inputs to the control system.

When all the sub-systems are independently assembled and functioning, they will interface with one another and function as a single machine. Additionally, the assembly of the subsystems should be enclosed inside of a frame to improve aesthetics and user safety.

Ultimately, this machine could be used as part of a cup-share program in coffee shops. Many coffee shops use take-away, single-use cups that are either paper, plastic, or styrofoam. In a trend towards becoming greener, some shops offer discounts to customers that bring their own reusable cups. This can be made even easier by having self-contained cup-dispensing and cleaning machines positioned in or near coffee shops. A user, before placing their order, simply pushes a button to receive a clean cup and the coffee shop can fill it. At a later time when many shops have this technology, customers can return the cup at any location and get a new one to be filled. Meanwhile, the machine cleans and then stores the dirty cup for a future user. Ideally, these machines would be conveniently located in most coffee shops so that it is easy for users to return dirty cups and receive clean cups.

Not only would this be a green initiative, but it is also a fiscally justifiable decision for both customers and coffee shops. Coffee shops would be able to reduce the amount of money spent on take-away cups; consumers would be offered discounts for bringing their own cups. Even if the machine had a monthly fee, consumers that frequent coffee shops could recoup the cost of the fees through discounts offered by

shops. Even though the shops would be offering a discount, they would be saving money on packaging, storage, and time spent ordering and handling deliveries. Shops could potentially even see increasing margins with this switch. It is a product that would be triply beneficial: shops save money, consumers save money, and the environment is cleaner with fewer single-use cups thrown into landfills.

## Chapter 3: Background

This chapter will discuss the different background that is pertinent to the design and prototyping of the machine. It will discuss the environmental need for a reusable cup program, current cup programs, FDA regulations, state machines, controls for mechatronic systems, and stakeholder analysis.

### 3.1. Environmental Need for Reusable Cup Program

Climate change mitigation strategies and global sustainability efforts have advanced significantly in recent years with heightened recognition of human influence over the environment. A 2019 US News Report, composed of data from twenty-six of the world's most influential countries, named climate change the greatest overall threat to international security (Figure 2) (Radu, 2019). Under the Paris Agreement adopted on December 12, 2015 by the United Nations Framework Convention on Climate Change, countries vowed to drastically reduce their carbon emissions and adhere to national climate change goals that coincided with a worldwide temperature reduction of approximately two degrees over the next thirty years (United Nations, 2016). However, even if national pledges are fulfilled by 2050, the effects will not be sufficient for the consummation of these projected global climate change targets. The plan must be updated by countries at the upcoming meeting in 2020, during which nations will report updates about their progress and reevaluate the feasibility and impact of their current aspirations (Skarbek, 2018). However, these updates may not be attainable, as many countries are already struggling to adhere to their present pledges.

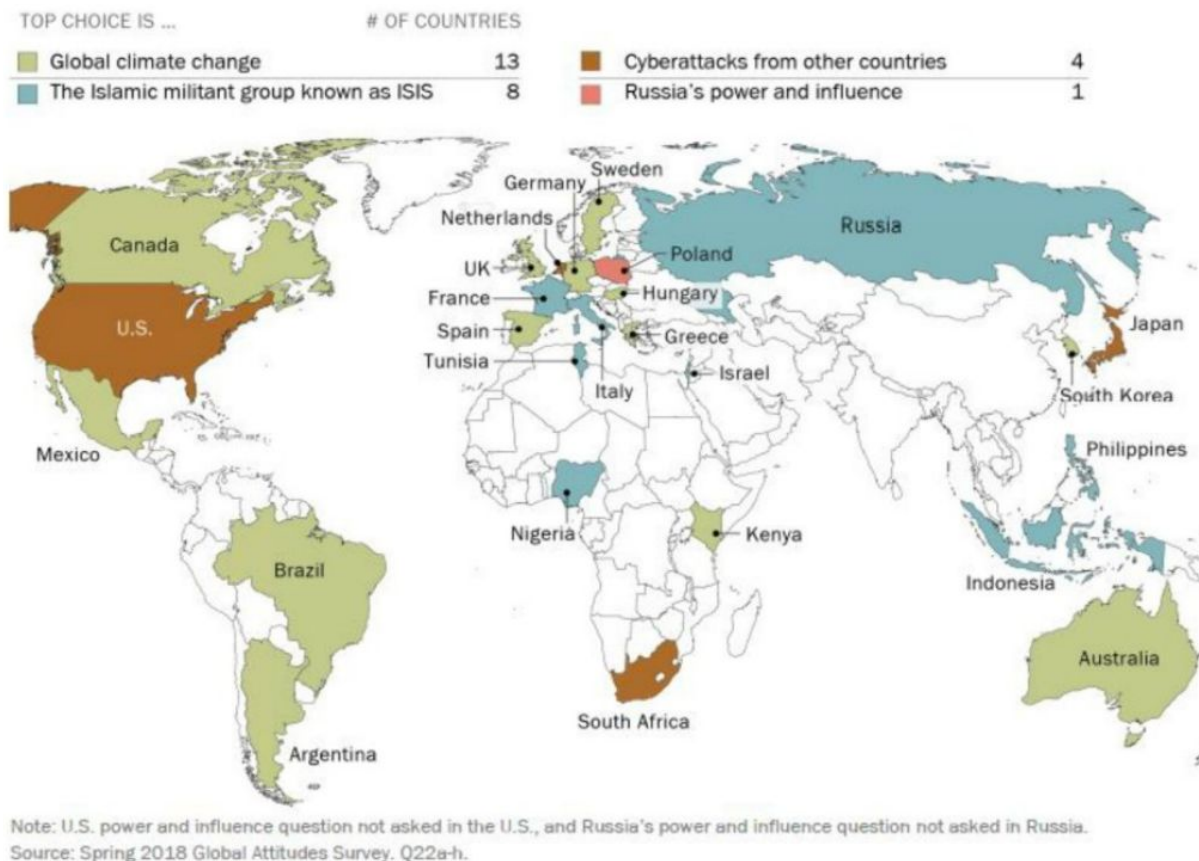

**Figure 2:** *Climate change is the world's most prominent threat (Radu, 2019)*

The shortcomings of these national demands require an alternative approach and the development of new, effective mitigation strategies. The startling rate of atmospheric degradation and the infeasibility of current combative measures establishes a need for innovative actions that target the three most prominent facets of environmental impact: natural resource use, pollution, and emissions. A debate that encompasses each of these major threats is that of recyclable and reusable products. The mobilization of these recycling and reusable material programs has swept the globe in the modern era as impacts such as the Great Pacific Garbage Patch cited in Chapter 1 have been cast under the public eye. The comparison between any reusable and disposable product can be evaluated across production, distribution and use, and disposal. Production factors consist of manufacturing emissions, energy and natural resource use, and the transportation of these resources and the finished product. Reusable cup utilization, in particular, has been a popular topic in recent years as the beverage industry is on the rise. When considering production alone, disposable cups are considered more environmentally-conscious to create. As portrayed in Figure 3 below, production of disposable cups uses 1/5000 of the energy used to produce glass cups, and around 1/4000 of the energy when compared to ceramic mugs (Evans, 2018).



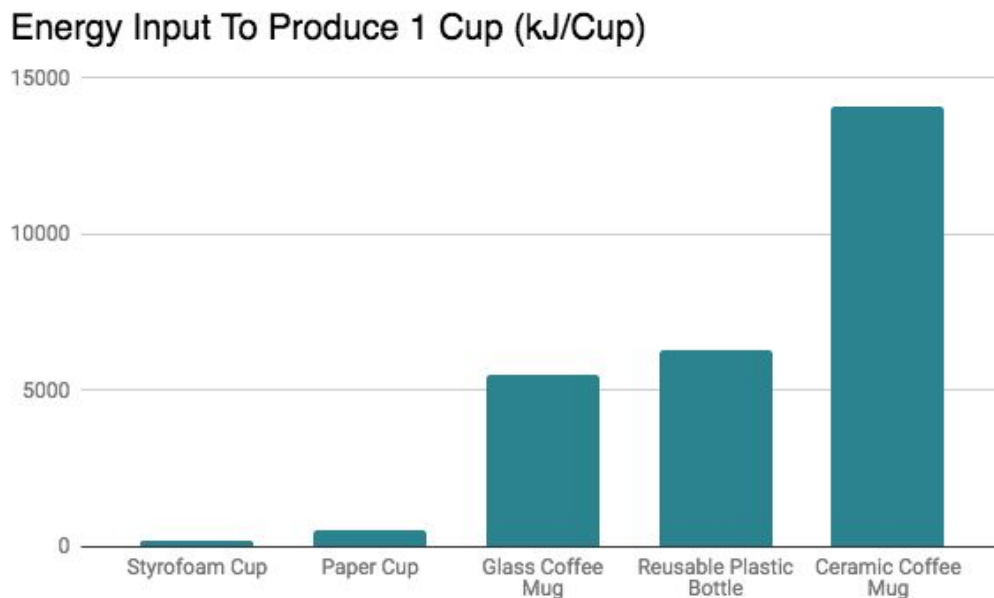

**Figure 3:** Production energy comparison for reusable and disposable cups

However, an all-encompassing climate impact evaluation is based on the entire lifespan of the cup, which includes water used to sanitize reusable cups, influence over human health, and disposal considerations such as pollution, emissions, and recycling cost. All such components evaluated, the longer lifespan of a reusable cup allows its initial energy consumption to break even over time, with reusable glass and plastic as the most energy efficient overall (see Figure 4).

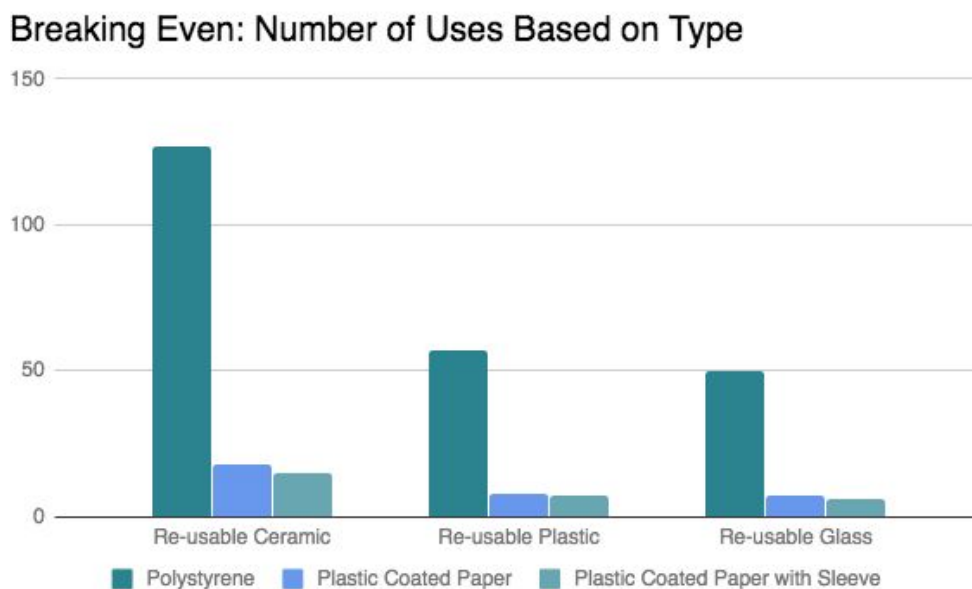

**Figure 4:** Break even comparison for reusable and disposable cups

Due to their low energy input, twenty and one hundred twenty-seven reusable cup employments are required to break even against paper and styrofoam, respectively (Evans, 2018). Beyond these uses, reusable cups continue to prove their environmental worth, as less than 1% of disposable cups are recycled, and an overwhelming majority end up in landfills (Figure 5) (Evans, 2018). While the direct impact varies by material, lifespan and end of life comparisons support the need for more reusable cup programs for global climate relief (Evans, 2018).

Disposal of Single Use Cups

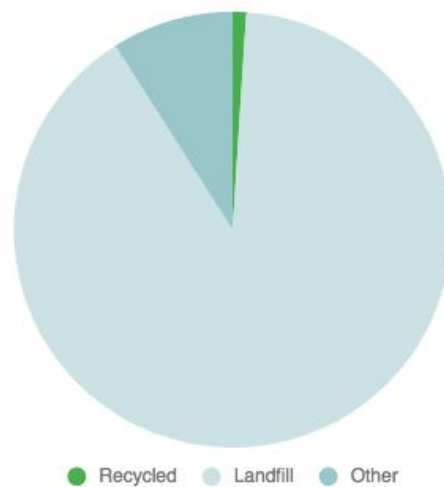

**Figure 5:** *End of life of disposable cups*

### 3.2. Current Cup Programs

In order to mitigate the widespread use of single-use cups, a growing number of people have opted to bring their own reusable cups to coffee shops. Some coffee shops, as well as major chains, give discounts to their customers who provide their own cup. As this trend has started to gain momentum, coffee shops and areas with a concentration of coffee shops have initiated their own reusable cup programs to do their part in reducing the use of single-use cups.



**Figure 6:** *Vessel Works reusable cups (Vessel, 2020)*

Vessel Works, whose reusable cups are pictured in Figure 6 above, is a small start-up out of Boulder, Colorado founded with the idea to get rid of the waste from single-use cups for hot and cold beverages by providing a reusable to-go cup in participating cafes. The Vessel Works to-go cup is an insulated stainless-steel mug that will keep a beverage hot or cold. When one visits a participating location, they can check out a free, reusable mug via an app and then later drop it off at a kiosk within five days to avoid a fee. Vessel Works's program is very similar to a bike-share program, and the company is anticipating their program will be a popular alternative to the billions of paper cups that end up in landfills each year. Vessel Works also believes that this program is a solution that consumers will adopt more quickly than asking them to bring their own mugs from home because this is a service that is provided to the customer (Vessel, 2020).



**Figure 7:** *Mugshare reusable cup (Mugshare, 2020)*

Mugshare is another reusable cup program that started in 2016 out of Vancouver, Canada. Mugshare partners with local cafes, schools, and businesses to supply mugs made from bamboo fiber. Customers can ask for a Mugshare mug, pictured in Figure 7, and pay a refundable two dollar deposit while placing their order. The customers are free to have their drink at the location or take it to-go and are not required to return the mug within a time frame. When the mug is returned to any Mugshare location, the customer will be refunded their two dollar deposit but the customer will not be refunded if they return a damaged mug (Mugshare, 2020).

### 3.3. FDA Regulations

Every four years, the Food and Drug Administration of the United States Department of Health and Human Services publishes an extensive report, the Food Code. This document discusses material, technical specification, and many other food and food-related regulations. As this project will involve cleaning cups for food consumption, the most important regulations specified within the Food Code pertain to cleaning and sanitization practice.

Before discussing the specifics of the Food Code, it is important to clarify which standards within the cleaning and sanitization section are relevant to this project. As an automated system, this project's device will not follow manual cleaning and sanitization standards; it will only abide by established warewasher standards. Warewashing standards can be broken down into two distinct categories: the general cleaning process and technical specifications.

### 3.3.1 The Cleaning Process

The cleaning of food-contact surfaces, which in the scope of this project relates to the dirty cups collected by the system, can be classified into three separate steps: precleaning, wet cleaning (washing), and sanitization.

Precleaning is used to soften and remove food debris through presoaking and scrubbing which facilitate the washing process. Following the reduction of food debris, the items to be cleaned can be transitioned to the washing process. Items loaded into a warewashing machine must be positioned to expose their surfaces to unobstructed spray and to allow the items to drain. The washing process must use an FDA approved wash solution, wash temperature, and wash pressure.

Wash solutions may consist of water or a chemical solution. A simple water wash solution must maintain a higher temperature than chemical solutions throughout the cleaning process and the minimum prescribed temperature varies across stationary rack, conveyor, single temperature, dual temperature, and multi-temperature machines. To satisfy all of the requirement, water used in spraying warewashers must exceed 82 °C (180 °F) and remain below 90 °C (194 °F) while maintaining a flow pressure greater than 35 kilopascals (5 psi) and lower than 200 kilopascals (30 psi). Successful water cleaning can be classified by following the previously stated requirements and achieving a utensil surface temperature of 71 °C (160 °F).

Chemical solutions may contain chlorine, iodine, or a quaternary ammonium compound. Chlorine solutions are broken into three concentration ranges with respective minimum temperatures for a pH of 10 or less, or a pH of 8 or less (Table 1).

**Table 1:** *Chlorine Solutions*

Concentration Range (mg/L)	Minimum Temperature pH 10 or less °C (°F)	Minimum Temperature pH 8 or less °C (°F)
25-49	49 (120)	49 (120)
50-99	38 (100)	24 (75)
100	13 (55)	13 (55)

Iodine solutions are more restricted and must exceed 20 °C (68 °F), have a pH of 5 or less, and be of a concentration between 12.5 mg/L and 25 mg/L. Lastly, quaternary ammonium compound solution shall exceed 24 °C (75 °F) and only be used in water that has 500 mg/L hardness or less. Successful chemical cleaning can be classified by the contact time of the solution with the utensil surface: at least 10 seconds for the chlorine solutions specified in Table 1 and at least 30 seconds for other chemical sanitizing solutions (United States).

### 3.3.2 Technical Specifications

The Food Code also details the requirements for measuring and controlling devices used in warewashing machines. Temperature measuring devices must be located in each separate tank of the system and where the sanitizing solution enters the final rinse manifold. These devices must also be accurate to plus or minus 1.5 °C (3 °F). Additionally, pressure measuring devices should increment by 7 kilopascals (1 psi) and be accurate to  $\pm 14$  kilopascals (2 psi) for the range given by the manufacturer. Machines that use fresh hot water must have a flow pressure gauge that displays the pressure before the water enters the machine. If upstream from the sanitizing rinse control valve, it must be mounted on a one-fourth inch iron pipe size valve (United States).

## 3.4. State Machines

In order to develop a sequential electromechanical system, a framework for the operations completed by the machine must be set in place. One type of framework, state machines, can be used to organize various system inputs and outputs into a sequential order of operations. State machines are computational models that can be applied to hardware or software to create multiple machine states in the applied system (Moore and Gupta, 2019). A state machine is comprised of multiple components: A finite set of states ( $Q$ ), an alphabet of transition inputs ( $\Sigma$ ), a transition function ( $\delta$ ), starting state

( $q_0$ ), and the total set of accepted states ( $F$ ) (Moore and Gupta, 2019). Finite state machines can either be defined as deterministic or non-deterministic. A deterministic finite automaton (DFA) accepts one input at a time to get from one state to another state. Figure 8 shows an example of a deterministic finite automaton, a vending machine (Gribkoff 2013). The vending machine starts at a resting state with \$0.00 input into the system. When a quarter or dollar is input into the system, the state of the system changes to represent the amount of money input in the system thus far, this would be represented by the display on the vending machine interface. The user will be able to input which item they would like at any point using the number pad, however, the input will result in a different output depending on the current state of the machine. If there is not enough money in the machine when the user selects an item, no change in state occurs because one of the conditions for that specific state change is not satisfied, even though an external input has been applied to the system. Once an appropriate amount of money has been input into the system, an item from the machine can be selected, and this input will result in the dispensing of the item, dispensing of additional money, and a return to the initial state of the machine.

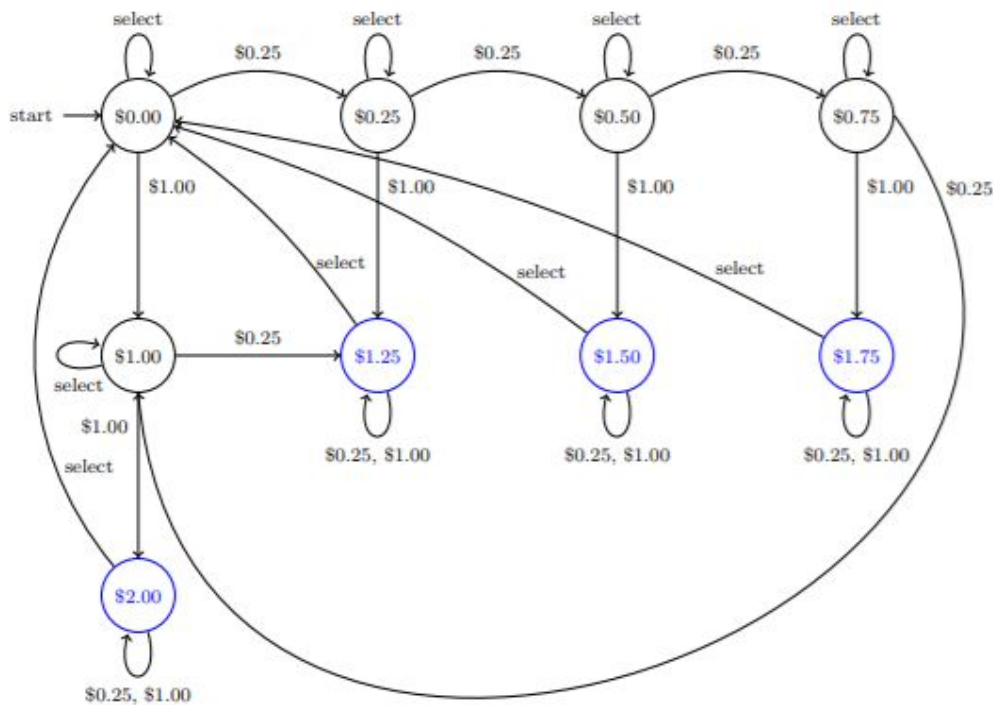

**Figure 8:** State machine diagram of vending machine

The application of DFA computational logic in this project will allow simple inputs in the system gathered from sensors, timers, or user inputs to change the current machine state in a simple manner. Additionally, DFAs allow sequential states to be implemented in a system simplistically.

Non-deterministic finite automata (NFAs) differ from their deterministic counterparts in that they can transition to and be in multiple states at once, using multiple transitional arguments (inputs) to go from one state to another (Goddard 2008). An NFA will accept a string of inputs if they lead to an accept state; if a string of inputs does not lead to an accept state, that string of inputs is ignored. This is further explained in Figure 9 below, in which an input string of 00 and 11 will lead to an accept state, but any other combination will have no effect on the state of the state of the machine. Furthermore, if an input of 01 was applied to the system, that string of inputs would terminate, leading to no accepted state output.

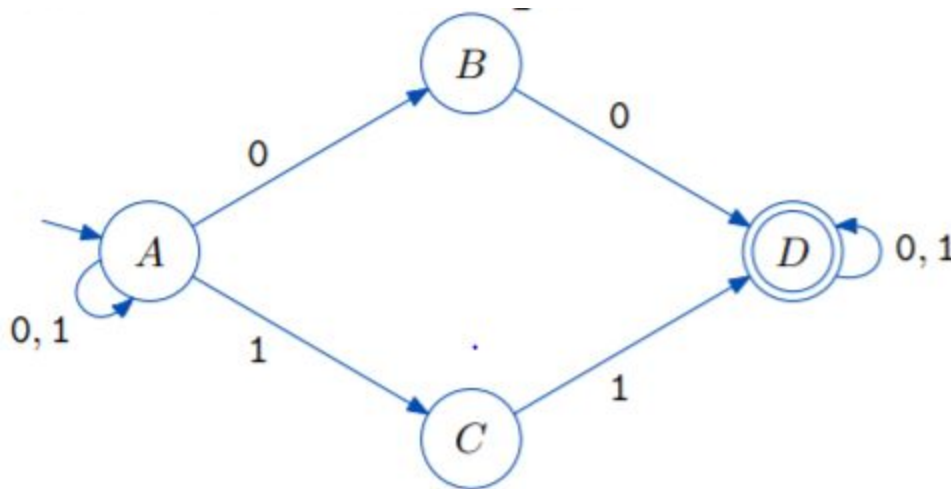

**Figure 9:** *Non-deterministic state diagram*

The application of non-deterministic computational logic into this project would allow more complex strings of inputs to be applied to the system, making resulting accept states to be activated under more simultaneous input arguments. An example of its application could be in the system checking multiple sensors for error inputs before switching to an alternate state.

All finite state machines can be classified as one of four entities: acceptors, classifiers, sequencers, and transducers (Keller 2001). An acceptor produces an output that indicates whether a given input is accepted by the system or not (Keller 2001). A classifier is very similar to an acceptor, but has the ability to produce a single output on multiple terminal or accepted states (Keller 2001). A sequencer only has the ability to produce one sequence of outputs, and can only read inputs in the form of single-letter inputs (Keller 2001). The transducer is the most relevant finite state machine class for this project as it considers the current state or inputs in the system and generates an output from an external input (Keller 2001). Two specific types of transducers can be used for control applications; Moore machines and Mealy Machines. Moore machines are simplistic finite-state machines which determine their output values solely on their



current state. Moore machines typically use a timer or global clock in a sequential system to go from state to state (Moore 1956). A Mealy machine is most similar to the basic definition of a finite state transducer as its output considers both the current state of the machine and an external input. For every input and/or state in a mealy machine, there is one corresponding output or resulting state that follows (Mealy 1955).

### 3.5. Controls for Mechatronic Systems

When designing and developing complex physical systems, mechanical and electrical components of design are often intertwined. The term mechatronic implies that the system is composed of mechanical components, though these components will be electrically controlled (Karnopp, Margolis, & Rosenberg, 2012). Basic instrumentation and actuation interfaces, feedback control loops, coordinated motions, logic functions, operator interfaces, and communication channels are all considerations when designing a control system (Auslander, Lemkin, & Huang, 1993). The ultimate objective of this system is to determine the control signals that will both satisfy the physical constraints and simultaneously minimize or maximize a performance criterion (Kirk, 2004). Therefore, when approaching a control problem, the following three steps need to be taken: modeling of the process to be controlled, determination of the physical constraints, and specification of the performance criterion (Kirk, 2004). In the case of the reusable cup machine, various types of control systems, including a closed-loop control framework that utilizes a system model and sensor measurement, were considered.

The modeling process itself tends to be difficult; making an overly-detailed and complex model will be unnecessarily difficult to analyze whereas an oversimplified model will fail to convey important results. Thus, it is important to note that no system can be modeled exactly and a designer should attempt to create the simplest possible model that still answers the questions of the system under study (Karnopp, Margolis, & Rosenberg, 2012). The simplest model that accurately predicts the response of the system to all anticipated inputs is the goal (Kirk, 2004). These models tend to have the same fundamental design. A dynamic system is given input variables either from its environment or a control system (Karnopp, Margolis, & Rosenberg, 2012). State variables are used to describe the current state of the dynamic system; states of the system are controlled by the history of control inputs (Kirk, 2004). These inputs cause the system to produce output variables which are either effects on the environment or outputs to the control system (Karnopp, Margolis, & Rosenberg, 2012). This is seen in Figure 10 below.

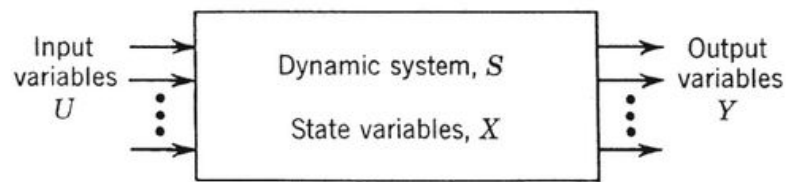

**Figure 10:** *General dynamic system model* (Karnopp, Margolis, & Rosenberg, 2012)

After creating the model, the next step is to determine the physical constraints. Any physical constraints that would impact the control system such as the capability of different components need to be determined. A model of a control system cannot exceed any physical constraints. A determination of the state trajectory, or state history, of a proposed system must be made to see if it is admissible (Karnopp, Margolis, & Rosenberg, 2012). To be admissible means to have a history of control inputs that produce a state that is within the physical constraints. This concept of admissibility is essential because it limits the range of values that can be assumed by states and controls; rather than testing all possible state trajectories in our design, only those that are admissible are tested (Kirk, 2004).

The third and final step when designing a control system is to specify and measure performance criterion. Simply put, this is the facet of the design that needs to be maximized (or minimized) to produce optimal results (Kirk, 2004). If the stated objective is to “Transfer the system from A to B as quickly as possible,” then the performance measure is elapsed time. However, if the objective is to “maintain the position and velocity of the system while minimizing consumed energy,” then the performance measure is less obvious. Sometimes, many iterations of a design while maximizing or minimizing different performance criterion is necessary to see which produces the most optimal overall performance (Kirk, 2004). The ultimate objective is to produce an optimal control; that is, to find an admissible control that causes the system to follow an admissible state trajectory that minimizes or maximizes the performance criterion (Kirk, 2004).

For processes involving the measurement of the performance criterion, it is essential to consider feedback mechanisms. A feedback loop is important in processes where a process variable is supposed to be held at a desired setpoint (Vandoren, 2014). The controller takes a reading from a sensor in the process and subtracts the value from the setpoint; if the value of the process variable has deviated from the intended value, it sends an error signal to the controller which makes an appropriate adjustment (Vandoren, 2014). This means that the entire state trajectory is communicated back to the controller so it may make necessary adjustments if there are any deviations from the optimal control trajectory (Kirk, 2004). Conversely, an open-loop controller does not

use feedback. Instead, it applies a one-time control effort when commanded and assumes that the desired outcome is completed (Vandoren, 2014). Because there is no feedback, the controller only knows that the initial input is optimal and has no way to compare any future outputs against the optimal control trajectory (Kirk, 2004). The comparison of these two processes is shown in Figure 11. The open-loop system tends to be much less accurate than the closed-loop system, though it tends to be faster (Vandoren, 2014). Within systems, it is feasible to use both open-loop and closed-loop systems in conjunction. Feedback can be provided to the controller via a closed loop. Subsequently, the controller may take many open-loop efforts to adjust according to the original feedback from the closed-loop system (Vandoren, 2014).

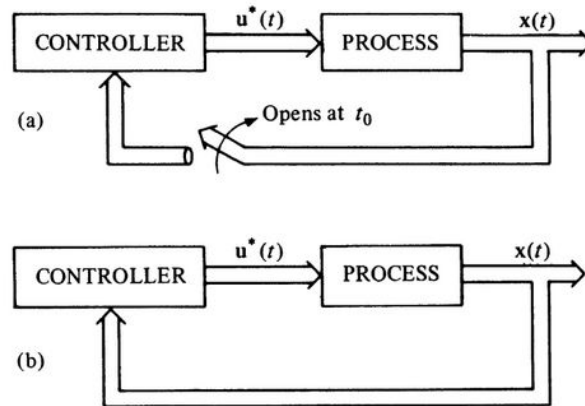

**Figure 11:** *Open-loop feedback (a) and closed-loop feedback (b)* (Kirk, 2004)

From all of this information, a more in-depth model of a control system can be created as seen in Figure 12. It begins with the controller receiving a command input and desired setpoint  $r(t)$  and subsequently delivering an input  $u(t)$  to the process. The control element, **a**, makes a change to the state of the process according to the controller's input. The process then adjusts and reaches a particular state as it gives an output  $x(t)$ . The process output is performed and then the measurement process reads the output  $x(t)$  and gives feedback  $y(t)$  to the controller, which can then adjust the input  $u(t)$  to the process accordingly. Note that the controller also gives input directly to the measurement process (Kirk, 2004).

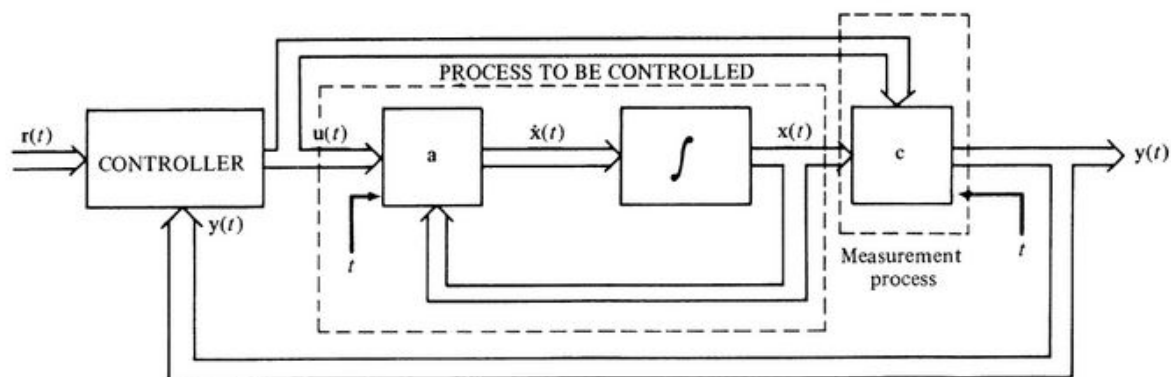

**Figure 12:** A closed-loop control model (Kirk, 2004)

To fully comprehend how these components of a control system interact, it is important to understand the notion of transition logic. Transition logic is applied in finite-state machines and is used for machine and system sequence control. Each state in the system is a period in which a well-defined operation is occurring and there is no transition to the next operation until specific transition conditions are met. Once these conditions are met, either from an external input or an internal computation, a state change occurs (Auslander, Lemkin, & Huang, 1993). Ultimately, this logic is very simple: once a specific condition is met, the state of a system changes. This logic is represented in Figure 13.

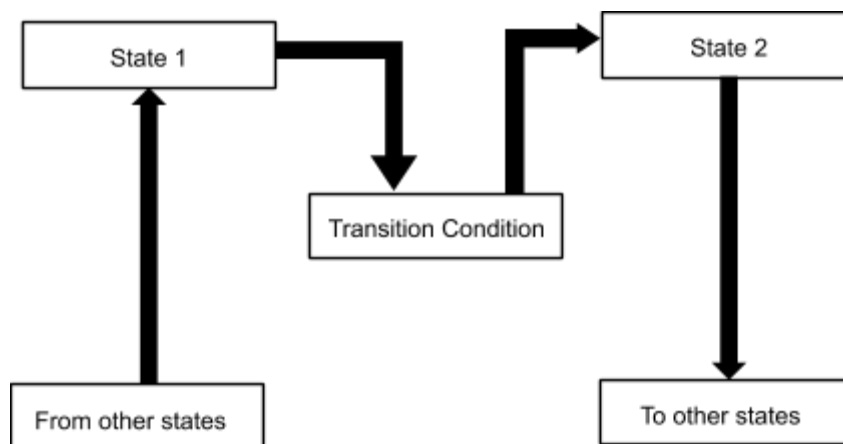

**Figure 13:** Visual representation of transition logic (Auslander, Lemkin, & Huang, 1993)

Transition logic functions by the master program continuously scanning for transition conditions while also executing the set of functions associated with the active system state. The current state of the system dictates which code is being executed. Note that the functions in each state must not be blocking; that is, none of the functions can

wait for events. Waiting is accomplished by the overall logic. This means that a transition condition has to be met only after multiple scans so that the transition must not happen before the system executes all the events associated with the current state (Auslander, Lemkin, & Huang, 1993). Transition logic begins with an *entry* function into each state, then an *action* function is performed on each scan. The action associated with a state is continually performed until a *transition* function is satisfied; once the transition condition is satisfied, the *exit* function executes and the *entry* function for the next state begins (Auslander, Lemkin, & Huang, 1993). This type of logic provides a simplistic software for control systems and can be scaled to fit any number of states.

After understanding the fundamentals of controls and the transition logic used, it is important to understand controllers and how they function. Often, microcontrollers are used for control applications. A microcontroller is a computer on a single chip that has a processor core, memory, and input/output (I/O) capabilities that is often used for a specific function. These microcontrollers can often be part of an embedded system, that is, they perform a specific task within a larger overall system (Abate, 2018). Microcontrollers are excellent for interfacing with sensors and other devices. Therefore, they are excellent for applications where components need to respond to various sensor readings and manual inputs (Parrish, 2017). Therefore, they tend to be application-specific and are used for predefined tasks (Abate, 2018). In addition, microcontrollers do not run a full operating system but instead execute written code as their firmware interprets it. Microcontrollers are still sophisticated devices that are excellent at interfacing with other devices; they simply do not run a full operating system, as it would be overkill for typical microcontroller applications (Parrish, 2017).

A very common microcontroller is the ATmega328, which is the microcontroller commonly used on the Arduino boards (Tawil, 2016). This project will use the Arduino UNO, a common, inexpensive microcontroller. The ATmega328 is a 28-pin, 8-bit microcontroller that is placed on the Arduino board. The rest of the board exists to support the microcontroller such as the USB interface chip, voltage converters, and the pins (Tawil, 2016). The board has six analog I/O pins, 14 digital I/O pins, and pins for power. This is shown in Figure 14. These boards are ideal for interfacing with sensors and being able to easily read, interpret, and respond to a wide range of sensor data. This means that Arduinos can be optimal for repeating a series of commands while using sensor data to make adjustments to different devices (Parrish, 2017). The shortcoming of microcontrollers is that they have less memory and lower speeds than microprocessors, though for the tasks they are used for microprocessors typically do not require these attributes (Abate, 2018).

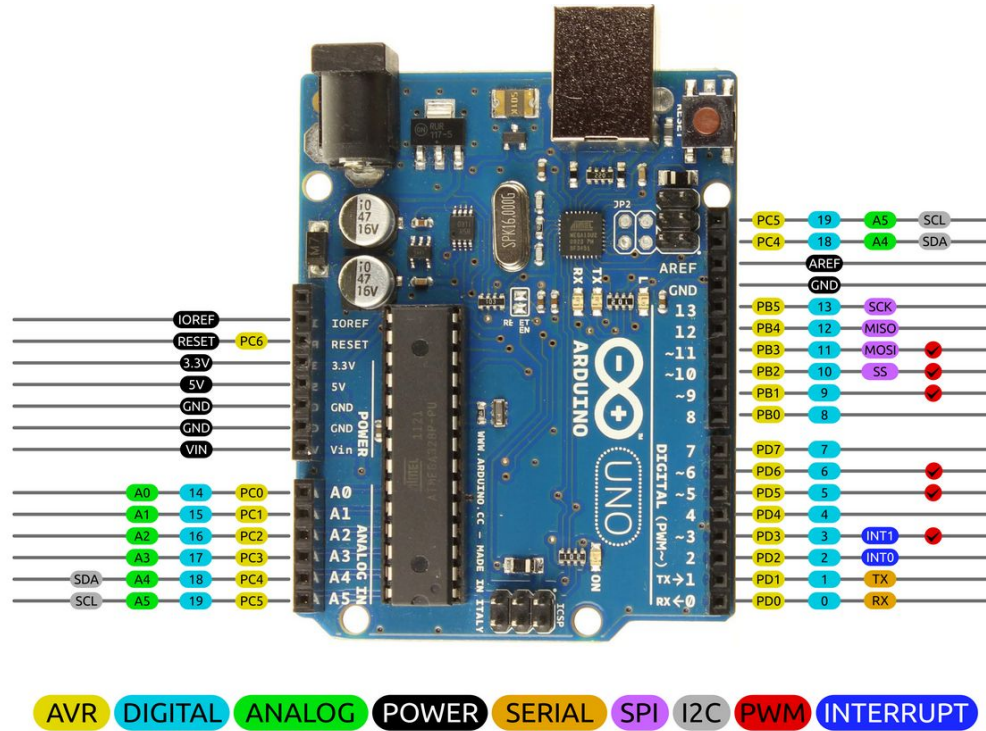
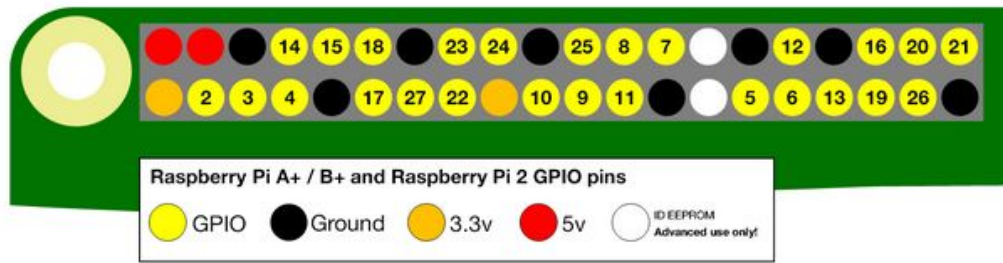

**Figure 14:** Pin layout of the Arduino UNO (Tawil, 2016)

Programming the Arduino is done using the Arduino integrated development environment (IDE). The language is based in C++ but has some variations, including some of its own functions. Every program, or “sketch,” that is written for the Arduino must have a *setup* and a *loop*. The setup function initializes variables, pin modes, and starting libraries. This function only runs once when the sketch is first uploaded to the Arduino. After this is done running, the loop runs continuously until the Arduino loses power. This loop is used to control devices through the I/O connections; the loop can be used for feedback as well, akin to the scanner mentioned in transition logic. Based on input values, the microcontroller can adjust outputs accordingly. Therefore, it is easy to see that the Arduino is ideal for application-specific, predefined tasks.

More advanced types of controllers exist for more sophisticated applications. One such example is the Raspberry Pi 3, which is essentially a fully functional computer. It has a dedicated processor, memory, a graphics driver, HDMI output, and an ethernet port for network capabilities (Fitzpatrick, 2017). In addition, the board has a 40-pin header with 27 general purpose I/O (GPIO) pins and pins for power; the pinout is shown in Figure 15 (raspberrypi.org, 2019). A GPIO pin is simply a pin that can act as either a digital input or digital output based on how it is set up. This means that, much like the Arduino, the Raspberry Pi can connect directly to sensors and other devices.

Because of the more complex nature of the Raspberry Pi, however, software is often necessary to interface with sensors and other devices (Parrish, 2017).



**Figure 15:** *Raspberry Pi pin layout* (rasberrypi.org, 2019)

The Raspberry Pi, from the manufacturer, runs an optimized version of Linux called Raspbian, though users are free to install whatever operating system they want (Parrish, 2017). In addition, the Raspberry Pi can easily be connected to the internet through its ethernet port or through the Wi-Fi capabilities; this makes transferring files to the Raspberry Pi using the File Transfer Protocol (FTP), a network-based file transfer service, easy (Parrish, 2017). When programming the Raspberry Pi, the user has the choice of which language to use as long as it is supported by the operating system, though Python is a common choice (Fitzpatrick, 2017). Because of the sophistication of the Raspberry Pi compared to the Arduino, the Raspberry Pi is a better choice for more complex projects that would normally be completed using a personal computer (Parrish, 2017).

When faced with choosing a controller for a system, the complexity of the task tends to be the deciding factor for choosing a microcontroller, a single-board computer or something in-between. Simpler tasks generally require only a simple microcontroller while more complex tasks demand a single-chip computer. For example, using a Raspberry Pi for simple actuation of a servo would be overkill. It is, however, possible to use both these types of devices in tandem. For example, an Arduino can act as a control board that executes commands issued by the Raspberry Pi. The sensor information from the Arduino can then be fed back to the Raspberry Pi for recording or acknowledgement (Parrish, 2017). These two devices can easily be connected by either the USB ports or the I/O pins (Parrish, 2017). Ultimately, choosing the right controller (or combination of controllers) is based on the complexity of the system.

### 3.6. Stakeholder Analysis

After initial research, two interviews were conducted to gather stakeholder data for the design. Questions were asked regarding both the reusable cup machine itself as

well as the potential associated cup share program. The first person interviewed was a manager at a coffee shop called The Bean Counter in Worcester, Massachusetts.



**Figure 16:** *The Bean Counter in Worcester, MA*

The individual was interviewed on September 24, 2019. Currently, The Bean Counter cleans their dishes with a standard dishwasher and cleans between 300 and 400 ceramic mugs and coffee cups per week. However, The Bean Counter sells about 1,500 cups of coffee a week, meaning that between 1,100 and 1,200 coffees per week are served in either paper to-go cups with plastic lids (for hot beverages) or plastic cups with plastic straws (for cold beverages). These cups cost 6-7 cents each and the lids cost 7.2 cents each. There is, however, a push towards sustainability: the paper cups are made with 100% recycled paper, one other Bean Counter location has switched to paper straws, and customers are able to bring their own reusable cups to be filled. Currently, this is not promoted and less than 2% of customers bring reusable cups. In addition, the business is not interested in offering a discount to people that bring their own cups.

The interviewee was, however, moderately interested in a cup-sharing program with other local coffee shops. They would be willing to have a kiosk in the shop and envisioned it to be approximately the size of a Redbox machine. They would be interested in a machine that collects, dispenses, cleans, and stores cups. Their biggest concerns were that they wanted a machine that had minimal maintenance and was essentially self-sufficient. One big design consideration that they mentioned is that they wanted to know if cups would be cleaned individually or in batches; this is an important



design consideration for the project as it would affect that rate at which cups could be accepted and cleaned. They were very interested in the sustainability aspect of the machine but were unsure of the business portion of the machine even though there have been successful cup-share programs elsewhere. They thought that it would be better suited for college campuses with multiple dining facilities where cup-sharing could be tied to students' college IDs. They would consider it, though, because other businesses that have taken part in similar programs have received increased visibility and publicity through positive news reports. They wanted to be kept informed throughout the design and prototyping process as they are interested in the outcome of this project.

During the interviews, the goal was to get the perspective of both local businesses and college campuses. Therefore, the second interviewee was the Director for Resident Dining at WPI. The interview revealed that WPI is actively considering a reusable cup system, though they have no concrete plans yet. For the 2019-2020 academic year WPI instituted Ozzy, a reusable container system. Students can get a reusable plastic to-go container and fill it with food from the dining hall. They then return it to a collection bin at the main entrance to the dining hall and grab a new container if they please. These containers are currently washed by an industrial dishwasher. Currently, Ozzy sees 100-120 daily users. During the implementation of this program, WPI considered a reusable cup system but wanted "to take it one step at a time." They are in a campus-wide push towards sustainability; napkins and utensils around campus are compostable, food scraps are given to a local pig farmer, and straws have been eliminated in Morgan Dining Hall with a push to eliminate them in the Campus Center as well.

The interviewee said that WPI would likely be interested in the project but provided some concerns. First, counter-space is limited in many dining facilities. Therefore, they said that a stand-alone system approximately the size of a vending machine would be preferable to a countertop model. Second, the design had to not only comply with FDA regulations, but also with the Massachusetts Board of Health. The cleaning temperature and chemical solution concerns align with FDA regulations, but there were also concerns about students using dirty cups on beverage dispensers. This is a violation of the code of health and they emphasized that students should not reuse dirty cups on beverage dispensers. For these regulatory reasons, they also said that this system may be better suited for campus-only use instead of having a system that also works with local businesses. Regardless, they did see this system as a potentially valuable addition to campus that could be implemented well at the Library Cafe, Planet Smoothie, Campus Center, and Morgan Dining Hall. The interviewee ultimately saw this system as another step towards sustainability for WPI and a project which could fulfill a reusable cup program that WPI is already pursuing. Therefore, they also want to be kept informed as the machine is developed and prototyped.

## Chapter 4: Initial Design Process

The design process described in this section follows the general form of overall machine requirements, subsystem-specific requirements, design exploration, design ranking, and design selection. Each of these steps is applied to every subsystem determined by the initial requirements gathering. This chapter follows the exploration of the initial overall design requirements and the two rounds of system designs. The focus of the designs is the cleaning subsystem, but the final selected design excellently merges this subsystem with the transportation and collection subsystems such that they were not necessary to explore.

### 4.1. Core Design Attributes and Criteria

The first step of the design process is to classify the subsystems of the machine. In the intended design, the main subsystems for a machine that accepts, cleans, and dispenses cups are cleaning, storage, transport, and user interaction (dispensing and collecting). The cleaning system washes, sanitizes, and dries cups; the transport system moves cups into, and out of, the cleaning system; the storage system holds cups that exit the cleaning system, and the dispensing and collecting systems feed into, and out of, the cleaning system. As emphasized by the above subsystem descriptions, the cleaning system is the most integral subsystem to the performance of the machine and it is the first subsystem to be designed. Additionally, it has a large number of constraints associated with it which makes it key in determining parameters of the other systems. Many of the proposed designs, including the final design, for the cleaning system included assumptions and decisions about the structure of the other surrounding subsystems.

In order for a design to be considered functional and complete it has to meet some minimum requirements. The minimum attributes necessary are the ability to:

- I. Distribute water throughout the system and clean the cup(s) with it
- II. Use some sort of chemical or process to ensure the cleanliness of the cup(s)
- III. Drain the water used to clean the cups
- IV. Pressurize water through nozzles
- V. Concentrate heat by insulating the cleaning area
- VI. Remove the wastewater from the system
- VII. Interface with the other subsystems
- VIII. Adhere to FDA regulations regarding cleanliness standards

In addition to the design requirements for the overall machine, there is a need for a design matrix to compare and rank the designs for each subsystem. Therefore, there are additional subsystem-specific criteria that each of the designs can be scored upon. These criteria include size, accessibility, energy consumption, simplicity, water and chemical use, water delivery, drainage efficiency, water tightness, and drying efficiency. For each of the criteria, a value between 1 and 5 was assigned when rating designs. It was also determined that instead of weighting each of the design criteria evenly, that some were more important than others. Thus, each was assigned a value between 1 and 3 to signal the relative importance of the respective criterion. Each of the criteria, their ranking scales, and their weighting are given and are explained fully in Appendix A. The design matrix that was used is shown below in Figure 17.

	Weighting (1-3)	Design 1	Design 2	Design 3	Design 4	Design 5
Size	2					
Accessibility	1					
Energy Consumption	2					
Simplicity	3					
Water and Chemical Use	2					
Water Delivery	3					
Drainage Efficiency	2					
Water Tightness	3					
Drying Efficiency	2					
<b>TOTAL</b>						

**Figure 17:** *The complete design matrix*

When scoring, the ranking (1-5) is multiplied by the weighting (1-3) to determine the total for each criteria. Weighting is a necessary part of scoring designs because it marks the importance and priority of the selected criteria to better diversify design scores. Without it each criterion is weighted equally and so the final scores do not take into account the importance of certain components, such as keeping the system as simple as possible. A 1-to-3 scale is appropriate because it is easy to determine the meaning behind each weighting (mild, moderate, and high importance, respectively) which facilitates the value assignment process. Once the design matrix was completed, then there was a clear way to rank each of the designs against one another by comparing common criteria. Thus, the team could begin their initial designs.

## 4.2. Initial Cleaning System Designs, First Round

The initial round of designs explore the design space and design options for the cleaning system. As this is an exploration stage, the generated designs are general and

their complete feasibility is not fully considered in determining design scores. Each design is compared against the others with an unweighted design matrix to determine what ideas are investigated further.

#### 4.2.1 Design 1: Descending Chamber and Rail Design

Design 1 uses a slotted linear rail with an attached gripper to grasp and translate the cup along a track. The cup is fed to the gripper by the transport system; this design presumes a conveyor belt though it is not a requirement of Design 1. Down the track, a clamshell descends and closes around the track to execute the cleaning cycle. After the cleaning cycle, the cup continues to a drying stage where compressed air is sprayed to dry the cup. Finally, the cup is dropped onto an exit conveyor to be sent to storage. A mockup of the general layout can be seen in Figure 18 below.

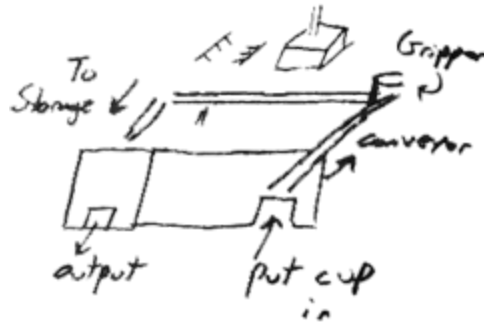

**Figure 18:** *General layout for the descending chamber and rail design*

A more specific drawing shows the clamshell design in Figure 19 below. The cup enters this stage with the opening upwards. The clamshell lowers into a fixed base sealed with a gasket when the gripper and cup are beneath, remains closed for the duration of the cleaning, and then lifts when the cycle ends. During the cycle, nozzles wash the cup from above while rotating to clean the entire cup. Given the way it is positioned the cup fills with water, so, after the cycle completes, the gripper must flip 180° the cup to drain its contents.

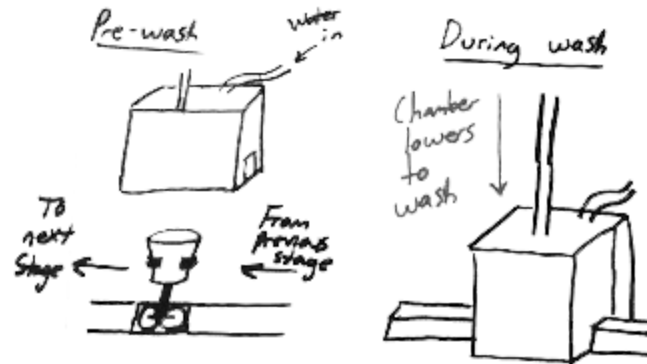

**Figure 19:** Drawing for the concept of the clamshell

This could be done with the chamber still sealed so that the nozzles could run their cycle again to concentrate on the outside of the cup or after the clamshell lifts and move on to the next stage. Regardless, once the cycle ends, the cup proceeds along the rail to be sprayed by air jets fixed above and below the track. The cup then leaves this stage dry and ready to be stored. Cleaning, draining, and drying is shown below in Figure 20.

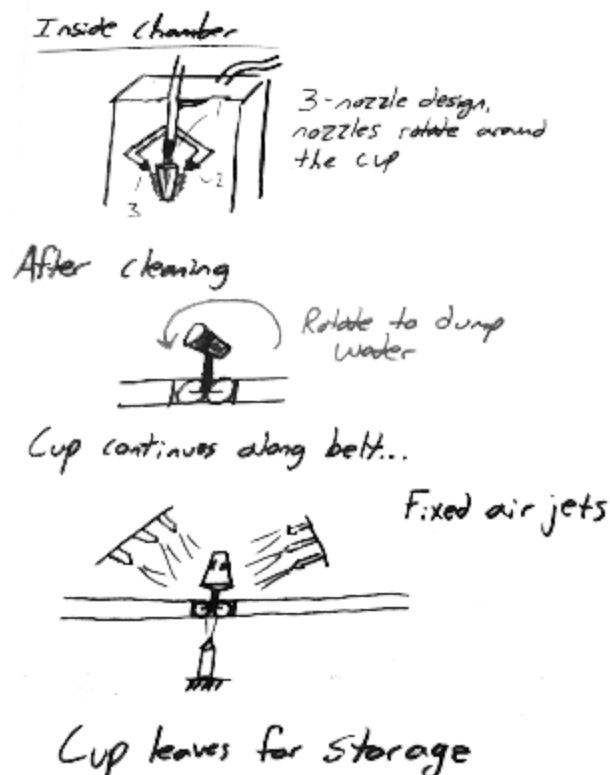
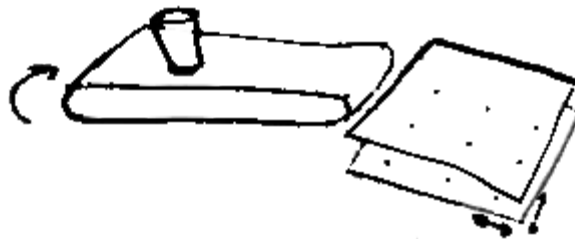

**Figure 20:** Cleaning and drying process of the cup with the descending chamber and rail design

The primary issue with this design is its overall complexity. It has many actuating pieces, including a gripper which is unnecessary as it overgeneralizes the task of holding the cup. Additionally, there is much more movement and actuation than necessary. Another important problem is the gripper will be inside the sealed clamshell during cleaning, which will result in electronics getting wet and ruined unless many steps are taken to carefully waterproof them. The method to move the gripper along the track is also complex and vulnerable to getting wet. Although this design met all of the necessary attributes, it still needs major modifications to be viable.

#### 4.2.2 Design 2: Translating Batch Cleaner V1

The goal of this design is to maximize the efficiency of the materials used to wash the cups that are placed in the sanitizer. To optimize said efficiency, the design utilizes batch cleaning, in which a set number of cups are all cleaned at once. The cups are fed onto a platform face up by a conveyor belt; the platform has the ability to translate in the X and Y direction with stepper motors. The cups are then filled with water to soak, and flipped by a mechanism that empties the soaking water and leads into the sanitizing stage. A sketch of this design can be seen in Figure 21 below:



**Figure 21:** *Translating Batch Cleaner*

While the design has the highest cleaning capabilities of the explored designs, it has a large amount of underlying complexity and is difficult to implement. There are too many moving parts that must work in conjunction with one another for the design to be feasible for the system's needs. In addition, the soaking and sanitizing stage requires the platform to be flipped which only further increases the complexity of the design.

#### 4.2.3 Design 3: Bar Glass Rinser V1

The main goal of this design is to use a bar glass rinser to wash the inside of the cup. To do so, a gripper attached to a conveyor belt places the cup face down onto a bar glass rinser and a hood with a hard stop and two spray nozzles closes onto the cup to

form a closed system. The hard stop presses the cup onto the bar glass rinser to initiate the wash/rinse cycle as shown in Figure 22 below. At the end of the cycle, a gripper moves the cup to the drying station where the same hooded concept contains the water spray from the blowing of the drying air jets.

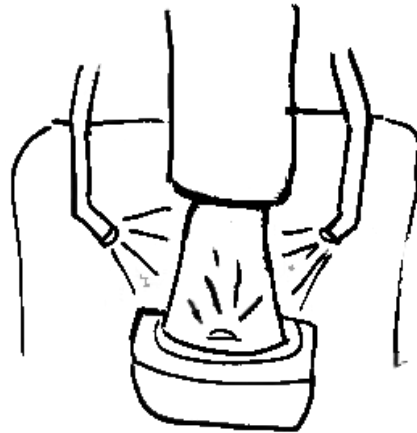
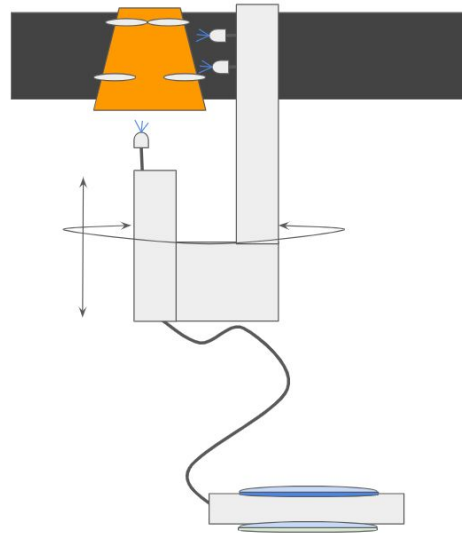

**Figure 22:** *Bar Glass Rinser*

The attractive feature of Design 3 is its general simplicity. It only has two moving parts: the grippers and the actuating hood. However, it only questionably applies to the required FDA regulations and wastes more water and chemicals than other designs. The cup is not sanitized in two areas, the base of the cup and the rim. Not cleaning the rim is particularly egregious; one of the most important places to sanitize the cup is the rim because this area comes in direct contact with the user's mouth and so poses the greatest health risk.

#### 4.2.4 Design 4: Actuated Nozzle Frame

The main goals of this design are to clean the inside and outside of the cup, hold the cup top down to prevent it from filling with water, cover a minimal area of the cup to ensure a full clean, and to be able to easily swap between a water rinse and a sanitizing rinse. To accomplish these goals the cup is held upside down by a gripper and exposed to internal and external spray from nozzles mounted on an actuating frame. A rinsing and sanitizing spray is delivered from the same nozzles using a variable water supply tank. The metal frame is actuated in two places with stepper motors. It rotates around and translates linearly on the z-axis where the center spray nozzle is located. The water and the sanitizing solution holding tanks can be rotated off to switch the type of fluid pumped to the nozzles. Figure 23 below shows the initial mock up of the design.



**Figure 23:** *The cup is cleaned by actuating the metal frame into and around the cup. The cup is held by a gripper.*

While the design meets the described goals, it still has some notable flaws. The primary concern is that the system is not able to be grounded or mounted in a clear or reasonable manner. Thus, the feasibility of the system is not immediately obvious. Additionally, the design does not take into account the possibility of water dripping onto the electronics nor does it explain how the water is intended to be captured and drained. Without drainage, the water would pool at the bottom and cause a multitude of issues for the machine. Lastly, using a gripper and a conveyor overcomplicates and overgeneralizes the transport of the cup. Actuating a gripper to grasp the cup introduces extra moving parts and does not take advantage of the known cup geometry.

#### 4.2.5 Design 5: Belt-Driven Corner Function Design

The final design divides a square top-facing region into four quadrants that each serve a specific function in the overall process from entry to exit of the cup, as shown in Figure 24. In this model, cups enter through a slot on the upper righthand region of the customer-facing side, and move along a belt. This first corner is a belt region that holds many cups at once for temporary storage. The cups then move to the second quadrant for sanitizing, which occurs by a plate lowering overhead and spraying into the upward-facing cup. The drying process occurs in a similar fashion, further along the belt in the third quadrant. Finally, the cups arrive at the long-term storage area in the fourth quadrant, and drop down into a stack to be dispensed at the bottom of the machine.



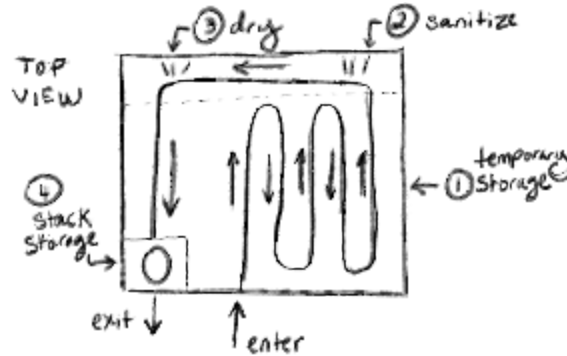

**Figure 24:** *Belt-Driven Corner Function Design*

The design of this model is simplistic and allows for maintenance accessibility through a top-facing cover. However, this model ultimately fails through the upward orientation of the cup. This orientation prevents proper drainage of the cup, as the cup fills with a significant amount of water during sanitation and has no described drainage mechanism. Thus, there would be difficulty achieving complete functionality of the drying region, as it is unlikely that any form of compressed air would be able to drive all of the water out of the cup. This is especially problematic as it would hinder the stacking storage in region four, causing cups in the stack to stick together and potentially grow bacteria between them, preventing adherence to FDA guidelines. Belt-driven movement also proves fairly complicated to bring to realization, especially with the intention of keeping mechanical components air-tight.

#### 4.2.6 Round 1 Results

To determine the best design in this round, the designs are individually scored based on the design criteria. Note that this first round of designs is scored on an outdated design matrix that includes one extra criterion (FDA regulation adherence) and does not use weighting. This extra criterion was later removed and transformed into a necessary attribute. Additionally due to the lack of weighting, the scores are close despite the designs being drastically different from one another. The round's scoring results are shown in Figure 25 below.

	Design 1	Design 2	Design 3	Design 4	Design 5
Size	4	2	5	3	4
FDA Regulations (cleaning)	5	5	3	5	5
Accessibility (Ease of cleaning components)	5	5	5	5	5
<b>Water System</b>					
Energy Consumption	3	5	4	3	3
Simplicity	3	2	5	3	4
Water and Chemical Use	3	5	3	3	3
Water Delivery	5	5	5	5	5
<b>Drainage System</b>					
Drainage Efficiency	3	2	5	4	1
Water Tightness	2	2	2	2	2
<b>Drying System</b>					
Efficiency	3	3	3	3	3
<b>TOTAL</b>	<b>36</b>	<b>36</b>	<b>40</b>	<b>36</b>	<b>35</b>

**Figure 25:** *Scoring of the first round of designs using an old design matrix*

After showing the designs and results to the advisors and discussing as a group, it was decided that another round of designs and a transformation of the design matrix was necessary. First, the design matrix needed to have weighting to have a clear-cut top design or two. In the original matrix, the best and worst designs were a mere 5 points apart, which was not enough to definitively choose a design. The new design matrix included weighting and refined definitions for each of the criteria, which was discussed earlier. In addition, the discussion revealed that all of the designs were likely over-designed in that they included many moving and actuating parts that were unnecessary. These moving parts only added severe complexity to the design while performing the same function that a much more simplistic design could accomplish with far less complexity. Many of the designs were complicated and required a high degree of precision. Thus, each of the team members were asked to complete another design and were urged to take a more simplistic approach. It was also suggested that the team chose certain constraints to make the designs more comparable, such as batch cleaning versus single-cup cleaning or in which orientation the cup enters.

### 4.3. Initial Cleaning System Designs, Second Round

After the feedback from the first round of designs, a second round of design work began. The team decided to make certain design constraints. First, the cup must come in from the transport system facing downwards. This decision was made because it forces users to input the cup facing downwards so they do not place a cup full of liquid in the machine. This helps prevent inadvertent damage to the machine and also prevents the cup from filling up with water during the cleaning cycle. Additionally, every team member was then to create both a batch and a single-cup design. When being scored with the design matrix, each team member would select only their preferred design (single-cup or batch) to be compared to the other designs. The team member would select the design that they felt the most comfortable pursuing, although both single-cup and batch were discussed for each team member. The input transport system and the method for exiting to storage were also to be included in each design. Each design did not have to be fully thought out, but a coherent design was necessary. The goal of this second round was to decide on an overarching design that could have the fine details decided upon or tweaked later.

#### 4.3.1 Design 1: Descending Chamber and Pneumatics Design

The first design uses a very similar setup to the descending chamber and rail design from the first round. However, in this case, the rail and gripper are replaced by an overhead-mounted rail with a suction cup end effector. The transport system consists of conveyor belts. From this conveyor belt, the suction cup, which actuates linearly along the rail, slides over and picks up the cup. It then drops the cup off in the clamshell. The pneumatic arm has a bend in it to allow it to reach under the clamshell. After the cup is cleaned, the suction cup picks up the cup, moves it to the drying area to be sprayed with compressed air, and then is dropped off on an exit conveyor. Note that the suction cup does also raise and lower in the z-direction. This is required because the bottom of the clamshell has been converted to use a bar glass rinser, which has a small protrusion that is used to house the nozzle that cleans the inside of the glass. Because of this protrusion, a very small amount of z-actuation is necessary, and this is accomplished by actuating the entire rail. This is shown below in Figure 26. The suction cup is run off of a vacuum generator that is powered by compressed air. The compressed air inlet is controlled by a solenoid.

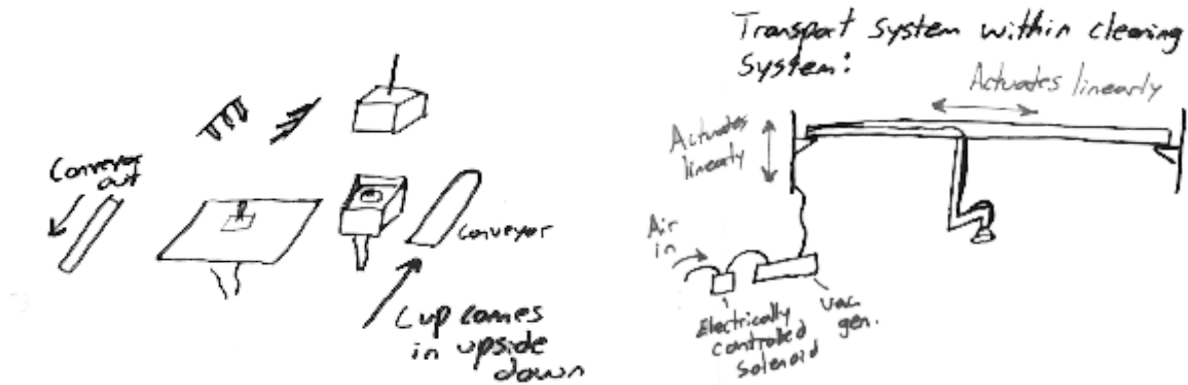

**Figure 26:** General layout for the descending chamber and pneumatics design

A closer look at the clamshell design is shown below in Figure 27. The bar glass rinser is activated by pressure, and thus when the clamshell closes, there will be a fixed piston that pushes down on the bottom of the cup. This, ultimately, turns on the bar glass cleaner. In addition, there are nozzles positioned to fully clean the exterior of the cup.

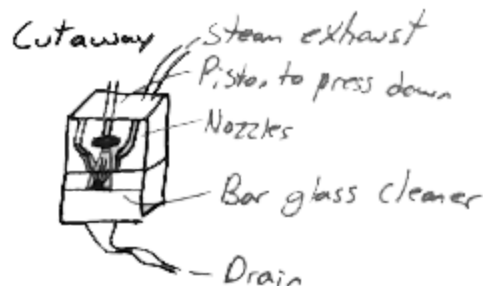

**Figure 27:** The clamshell design using the bar glass cleaner

This single-cup design can be transformed into a batch design with relative ease. Instead of using a single clamshell, multiple clamshells can be used. This requires almost no modification other than adding extra clamshells. Alternatively, the clamshells could be arranged in a 2-by-2 pattern, which would then require 3-axis linear actuation for the pneumatic arm. Both of these options are shown in Figure 28 below. Alternatively, in either configuration, instead of bar glass cleaners, there could be just a nozzle below the cup with the overhead pistons still there to prevent the cup from moving.

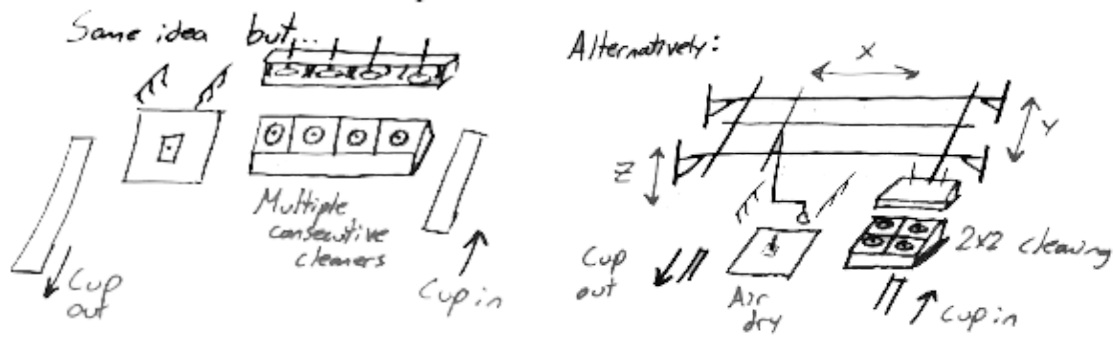
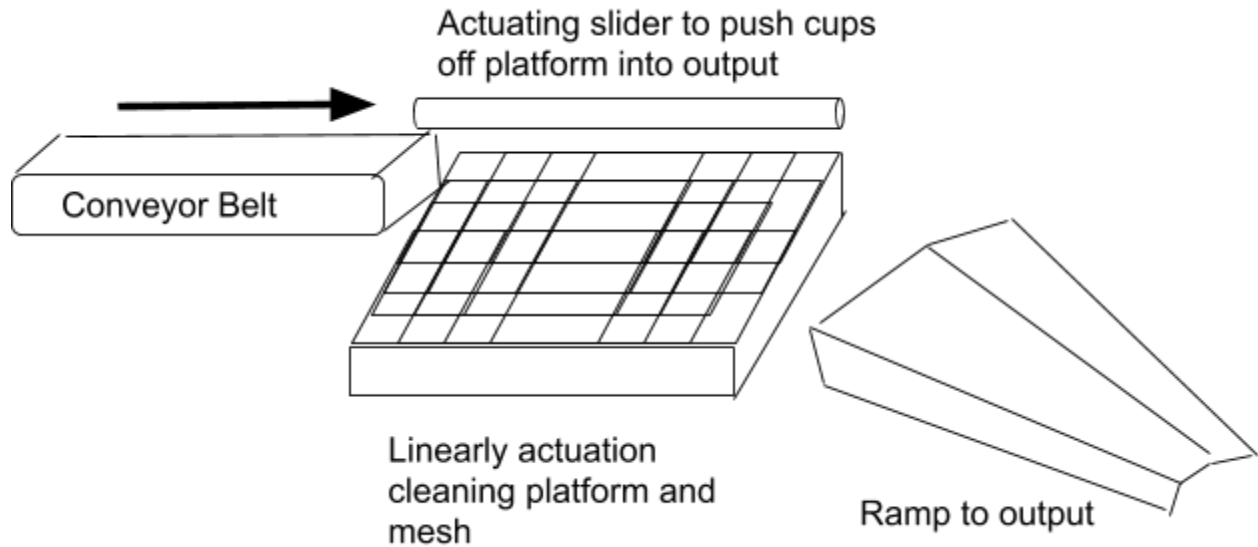

**Figure 28:** Multiple consecutive bar glass cleaners or a 2-by-2 arrangement of bar glass cleaners for batch cleaning.

While this design is significantly better than its Round 1 variation, it still has some shortcomings. The first shortcoming is that the pistons that hold the cups down prevent water from cleaning the top. Because the goal is to clean the entire cup, this is a significant issue. Additionally, when the pneumatic arm removes the cups from the clamshell the cups are still wet. Although the arm is applying suction to the dry bottom of the cup, there is still potential for it to pick up moisture. Lastly, while this is a simpler design than the Round 1 version, it is still complicated and has many moving parts. To fix the above described issues and construct this design would be a major undertaking.

#### 4.3.2 Design 2: Translating Batch Cleaner V2

This design is a more detailed and simplified version of the Translating Batch Cleaner presented in Round 1. This design removes the soaking stage and instead opts for a two stage sanitizing system; it heats up the cups with hot water to remove grime and then sanitizes the surface of the cup. The design keeps the translating bed and incorporates a sensor on the conveyor to detect any unwanted items placed into the machine and dispose of them. A drawing of this design can be seen in Figure 29 below:

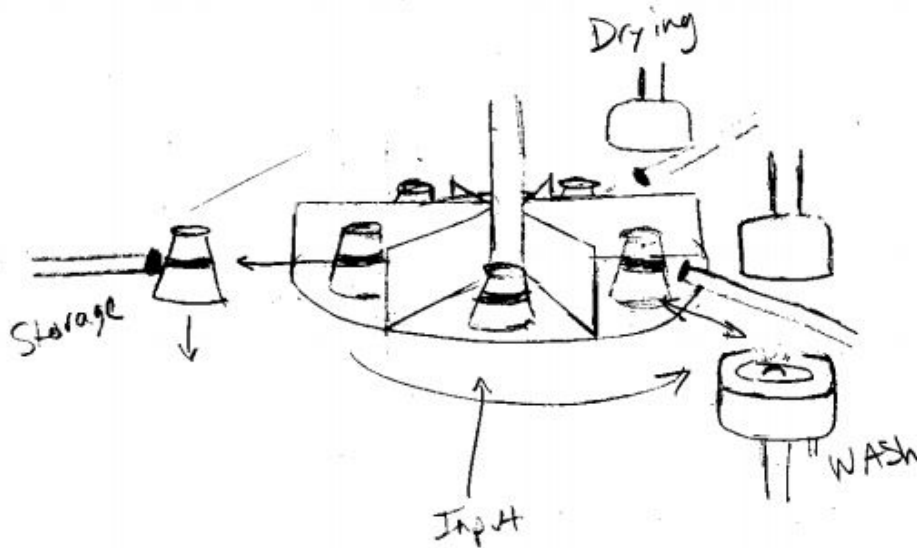

**Figure 29:** *Translating Batch Cleaner V2*

Although the core components of the design are simplified, it is still too complex for the project's needs. The actuation of the washing platform is helpful in placing the cups, but could easily be eliminated through manual placement on a smaller platform. In addition, batch cleaning turns out to not be more valuable than other features such as accessibility or cleaning capability, so the major advantage of the design is negated.

#### 4.3.3 Design 3: Bar Glass Rinser V2

This design implements a rotating platform to transport cups to different stations. This design also employs the same form of sanitization/rinsing as in Bar Glass Rinser V1. As the platform rotates, grippers located at each station retrieve and place the cup in their corresponding stations as shown in Figure 30.

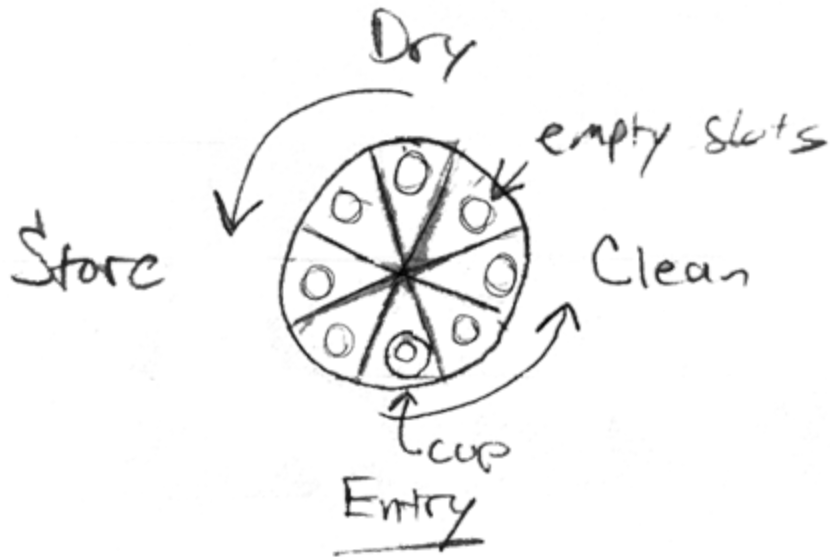

**Figure 30:** *Bar Glass Rinsers V2*

The major drawback of this design is the use of four grippers to move cups into the sanitization/drying stations, which heavily over complicates the process of moving cups. The design's footprint is also incredibly large as the use of grippers requires a large amount of space to freely actuate.

#### 4.3.4 Design 4: Sequential Function Rotation and Hood Actuation Design

This design focuses on compactness without sacrificing functionality and is inspired by the last design in this section, Design 5. It fully encapsulates the cleaning system and the transport system in a small floor footprint. Each partition is responsible for a different function (see Figure 31).



**Figure 31:** *Overhead view of carousel*

The entry partition is where the cup enters the system. Figure 32 below displays the function of the rinsing, sanitizing, and drying partitions.

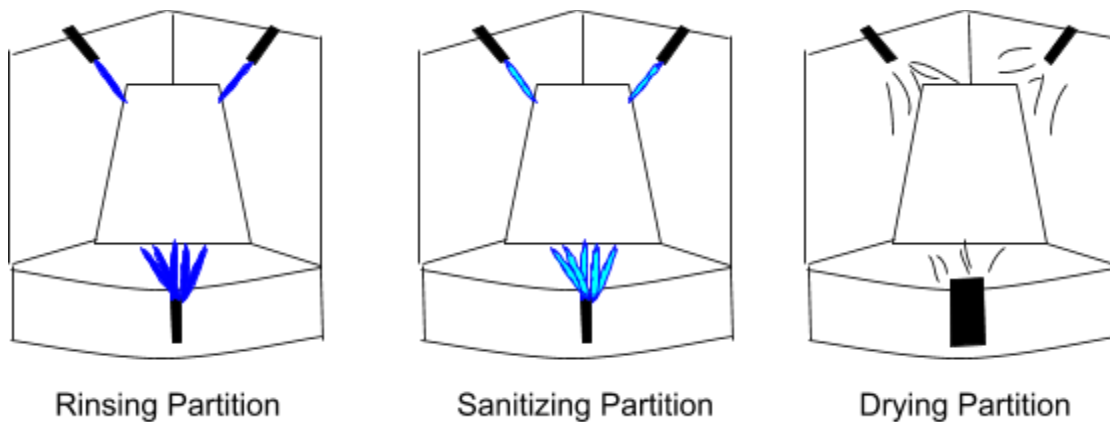

**Figure 32:** *Cleaning and drying partitions*

The final partition has a hole in the floor for the cups to exit the carousel and move into the storage and dispensing system.

Notably, this design eliminates many of the moving parts present in previous designs and significantly reduces the machine's footprint. However, it does not easily and clearly guarantee fully cleaned cups or minimize water and power use.



#### 4.3.5 Design 5: Multifunctional Rotation and Hood Actuation Design

The final design is identical to the previous design in nearly all aspects. However, rather than sequential functionality, this design proposes multifunctional compartments to enable batch cleaning, as shown in Figure 33. In this sense, the actuation hood lowers to trigger the functions of the rinse, sanitation, and drying sections at one time. However, this is not necessary as it would essentially use the same amount of resources, may cause some cups to be between cycles for extended periods of time, overcomplicates the function of the compartments, and the required wiring and tubing for each compartment would be overcrowded. Overall, as cited in the previous design section, this model simplifies the system without compromising the functionality, as only basic rotation and actuation mechanisms are required.

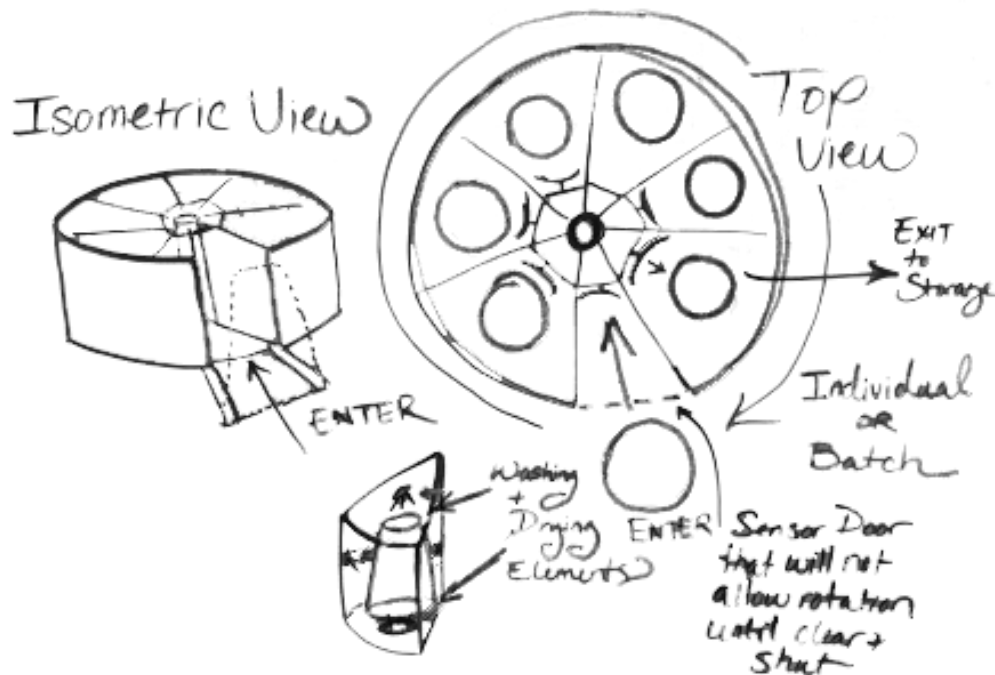

**Figure 33:** Multifunctional Rotation and Hood Actuation Design

#### 4.3.6 Round 2 Results

Similar to the first round, the team met and compared their designs. This time, each member of the team selected their preferred design (batch or single-cup) to be compared to the other designs. Because the second round of design was more structured, more comparable designs were created. In addition, the designs were overall

more simplistic and thus seemed more feasible. The comparability and the feasibility of this round of designs allowed a final design to be selected. Recall that this round of designs used the updated design matrix with the revised criteria and the weighting. The results are tabulated in the design matrix shown below in Figure 34.

	Weighting (1-3)	Design 1	Design 2	Design 3	Design 4	Design 5
Size	2	2	4	2	5	5
Accessibility (Ease of cleaning components)	1	2	4	3	5	5
<b>Water System</b>						
Energy Consumption	2	2	4	2	5	5
Simplicity	3	1	3	1	4	5
Water and Chemical Use	2	2	5	2	3	4
Cleaning Capability	3	3	5	3	3	4
<b>Drainage System</b>						
Drainage Efficiency	2	3	5	5	5	5
Water Tightness	3	4	3	3	5	5
<b>Drying System</b>						
Efficiency	2	3	4	5	5	5
<b>TOTAL = x/100</b>		<b>50</b>	<b>81</b>	<b>56</b>	<b>87</b>	<b>95</b>

**Figure 34:** Design matrix showing results for the second round of designs

From this design matrix, Design 5 is the highest-scoring design with Design 4 ranking close behind. Based on this, Design 5 was chosen as the base design concept for our final product. To further develop the specifications of the team's chosen design, a CAD model was developed; this can be viewed in Figure 35 below.

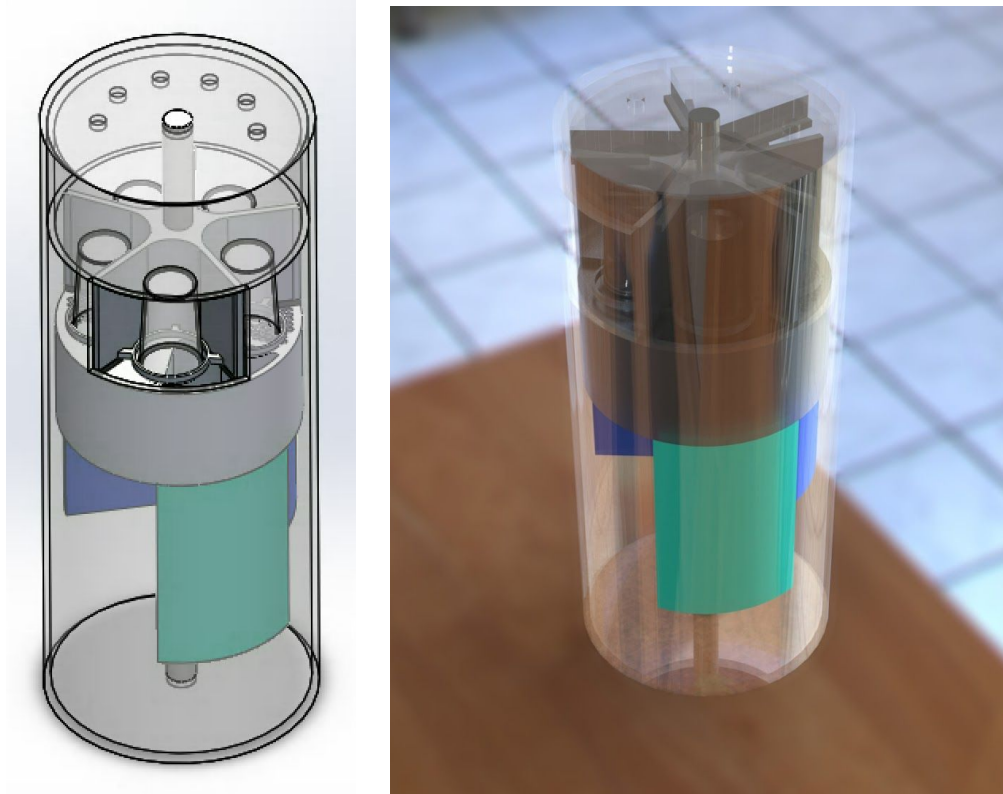

**Figure 35:** Chosen model and render based on Design 5

#### 4.4. Design of Supporting Subsystems and Structure

With the primary system of the machine designed, designs for the dependent, supporting subsystems, the storage and user interaction (collecting and dispensing) subsystems, can be created. The design of the cleaning system removes the necessity for a transport system for the input of the cup and a collection system as cups are transported by the rotation of the central carousel and users place cups directly into this carousel. This leaves the storage and the dispensing systems. They support the central cleaning system; therefore, the team worked together to find a design that could be integrated with the chosen design for the cleaning system.

The simplest form of a storage system is a stack of cups that sit within the machine waiting to be dispensed. Seen in Figure 35 above, the cups drop after they are dried and fall into the green tube. They stay stacked here, with the opening-down, until they are dispensed. Thus, the team began to focus on a dispensing system. The first design is shown below in Figure 36. The stack of cups rests on a closed door. When the user requests a cup, the grippers actuate linearly and slide under the lip of the second

cup, preventing it from falling. After this occurs, the bottom doors open to allow only the bottom cup to fall to the landing pad below.

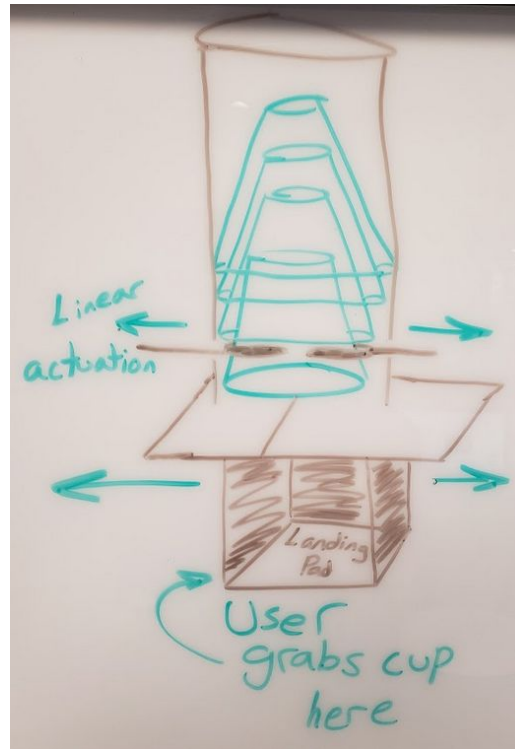

**Figure 36:** *Initial design drawing for Dispensing System V1*

The other design can be seen below in Figure 37. It takes advantage of the lip of the cup to dispense one cup at a time but requires the cups to be stacked mouth-up. A servo actuates to pull the stack of cups backward which separates the bottom cup from the rest of the stack. The separated bottom cup drops through the widened gap at the back to finish the dispensing process. However, this second design requires that the cups have lips which complicate the efficient and effective cleaning and drying techniques for smooth rimmed cups. It also requires cups to be flipped before reaching the storage system, which caused concern regarding the fit of the flipping mechanism under the cleaning system. Therefore, the first design was developed further and used in the final product.



**Figure 37:** *Dispensing System V2*

Upon further discussion and exploration of the Dispensing System V1, there were concerns about the cup being delivered to the user face-down. The team decided that the cup should be flipped after it is dispensed, and, instead of using any actuator to flip the cup, the easiest method was to allow the cup to hit a ledge as it is dispensed, causing it to rotate and land so that the opening was facing upwards. This is shown in Figure 38 below. The intended functionality requires that the cup flip into a funnel-style exit to help it smoothly finish the flip. This design minimizes the use of actuation and takes advantage of gravity to help rotate the cup. It is a simplistic yet effective addition to the dispensing system.



**Figure 38:** *Demonstration of the cup hitting a ledge and flipping*

Now, all necessary subsystems are created: the cup can be input, cleaned, and dispensed on command. The final step is to find a way to hold the components together. Much of the exterior housing that holds the components together in the prototype is made using acrylic as it is clear, inexpensive, and can easily be cut on a laser cutter.

There was also an abundance of t-slotted aluminum available to the team during the machine's assembly, so the prototype frame is built out of t-slot aluminum while different support components for the systems are made out of acrylic and anchored to the aluminum frame. Once this initial design of the cleaning system, storage system, dispensing system, and support had initial designs, a final design could be created.

## Chapter 5: Finalized Overall System Design

This section focuses on the selected design. It considers the two major subsystems, cleaning and storage/dispensing, individually while highlighting the encountered design considerations and challenges. It also includes a brief description about the structural components.

### 5.1 Cleaning Subsystem

This section details the design of the cleaning system. It begins with a general system description and overview, and then discusses the design of different components within the system such as stepper motor requirements, cycle length, fluid and air delivery, electrical design, and program design.

#### 5.1.1 General Description

The cleaning system primarily consists of a carousel-style holder that rotates inside of a tube with each compartment receiving a different treatment. Figure 39 below expounds upon the mechanical components of this system with notations A-G, starting at the top of the t-slot frame with a belt system that transfers the rotational motion generated by a mounted stepper motor to drive the central rod running throughout the system.

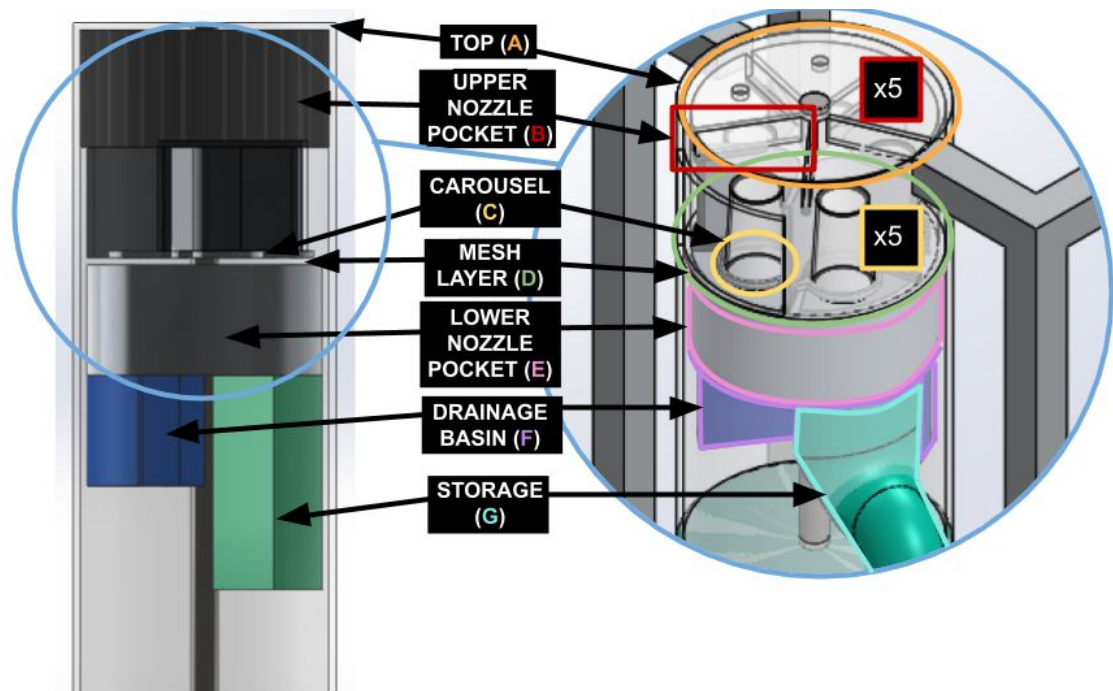
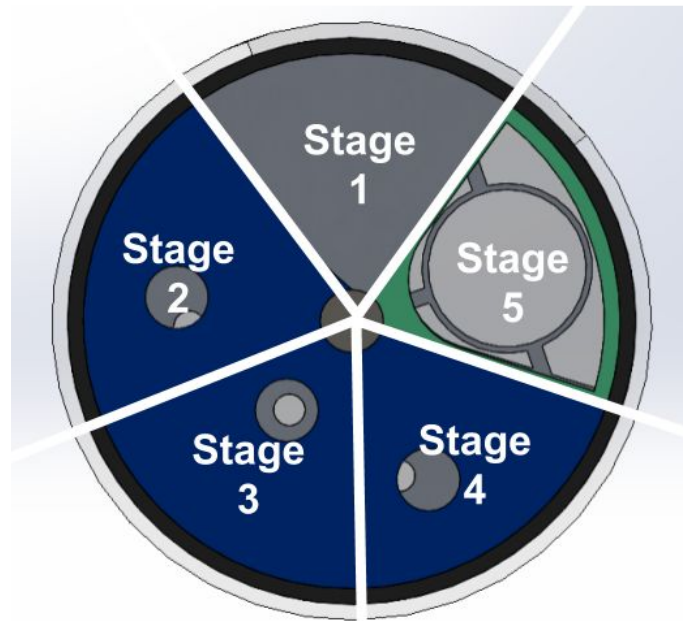

**Figure 39:** *Cleaning Subsystem, consisting of: Top (A), Upper Nozzle Pocket (B), Carousel (C), Mesh Layer (D), Lower Nozzle Pocket (E), Drainage Basin (F) and Storage (G)*

The rod is mounted by a bearing and runs through the core of the components shown in Figure 39 above. Although not shown in the above image, the intended functionality of the mechanism requires that water and air nozzles be fed into the system from the top and bottom. The nozzles are segregated by function, with the upper nozzles held by fixtures (not shown) within the top piece (Denoted A), and oriented within the compartments of the upper nozzle pocket (Denoted B). Conversely, the lower nozzles feed through fixtures in the drainage basin (Denoted F) and into the lower nozzle pocket (Denoted E). These nozzles spray the cups from two directions in three different wash stages, contingent upon physical stage within the carousel (Denoted C). The stages are composed of a chlorine solution wash, a water rinse, and a pressurized air dry cycle. The complete cycle is shown more explicitly in Figure 40 below. The cup is placed by the user face-down onto the mesh layer (Denoted D), within the confines of an available ring of the carousel. This is stage one. The ring guides the cup along the mesh to stage two. Stages two, three, and four follow the respective cycles noted prior as wash, rinse, and dry. The mesh supporting the cup in these regions has a central hole to maximize spray from the nozzles below, surrounded by finer holes that allow liquid waste to collect in the sloped drainage basin below and channel out of the system through a series of piping. Finally, in stage five, the ring guides the cup over a hole in the



mesh that leads the cup into the storage compartment below (Denoted G in Figure 39). The carousel rotates with the rod, while the other components in the tube are fixed to the exterior walls and, in vertical alignment with one another, remain stationary. The rod, as stated previously, is driven by the belt system and stepper motor mounted above. This is an ideal design for the system because it allows all functions to be driven by a single motor, and thus the rotational motion of only one component.



**Figure 40:** *Carousel Cycle Stages (Seen from below)*

### 5.1.2 Actuator Selection

The required torque for the system's motor is calculated for optimal performance by using the moment of inertia of the rod mounted with the carousel multiplied by a desired angular acceleration:

$$\text{Torque} = \text{moment of inertia} * \text{angular acceleration}$$

Determining the required torque of the stepper motor about the z-axis of the cleaning system's central shaft consists of selecting a desired angular rotation, selecting a desired rise time, obtaining the moment inertia of the carousel assembly, deriving angular acceleration, and adding a safety factor. As the angular velocity is not crucial to the performance of the machine, a velocity that provides a satisfactory time period to advance the carousel one stage in the cleaning cycle should be used. For this machine and application the value was selected to be 2 seconds for  $\frac{1}{5}$  of a rotation, or 6 rpm. Similarly, the rise time of the motor is not crucial to the function of the system and was selected to be .1 seconds as it was low and made the following math simpler. Once the

two above values are selected, the moment of inertia of the carousel is found through a SOLIDWORKS assembly. This machine's central carousel (seen in Figure 41) is a vector of approximately  $[0.0044 \ 0.1000 \ 0.1000]$  kg/m<sup>2</sup> where the values correspond to the x, y, and z axes, respectively.

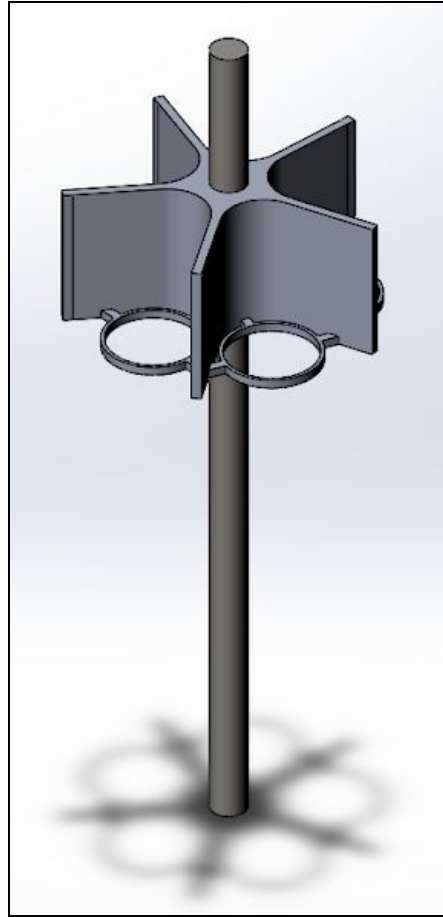

**Figure 41:** *The central axis*

Then, the angular acceleration is found by converting the desired angular rotation into radians per second and dividing by the desired rise time. Lastly the torque is found to be .6286 N and multiplied by a factor of safety of 3 to arrive at the final torque used for motor selection, 1.8558 N. The larger factor of safety is to assist in accounting for unconsidered actors on the system. Generally, these are friction forces such as those created by gasketing between each section of the carousel and the cup(s) dragging across the mesh floor. A MATLAB script was written to help calculate these values and it can be found in Appendix C.

Of the three major types of motors; DC motor, stepper motor, and servo motor, the main decision in selecting actuator type for the above application is between a stepper motor and a DC motor equipped with an encoder. The need for full, continuous

rotation disqualifies servo motors from the actuator considerations. The major advantage of stepper motors over DC motors is their ability to provide large torque at lower speeds with high precision. With the carousel rotating at low speeds, requiring a significant amount of torque, and needing reliable positioning precision, the choice is clearly a stepper motor.

### 5.1.3 Cycle Length Determination

In this subsection, the cycle length for the deep cleaning cycle is determined. Initially, cycle length was going to be determined by the amount of time that the air in the deep cleaning compartment would take to reach thermal equilibrium with the water exiting the nozzles. After performing calculations and seeing large amounts of time for equilibrium, using higher chlorine concentrations was found to be preferable to reduce cycle time and not require thermal equilibrium.

#### **Finite Element Analysis Approach**

One essential design consideration is to determine the length of the rinse, deep wash, and drying cycles. The carousel only rotates after the slowest of the three complete its cycle, which is the deep wash cycle. The pre-rinse is not intended to be extremely thorough, and the air drying would be quicker than the deep wash still. Originally, the cycle length was to be decided based upon heat transfer calculations that determined when the air in the compartment reached thermal equilibrium with the water exiting the nozzles. This began with a SOLIDWORKS thermal analysis of the system in steady state conditions to see how the heat dispersed. A model using the carousel, central rod, lower nozzle housing, drainage basin, storage chute, and exterior cover was used for the analysis. It is assumed that the water is  $\sim 105^{\circ}\text{F}$  when it exits the nozzle, and thus the surface of the cup should be at this temperature as it is in constant contact with the water. All parts were made out of acrylic, besides the aluminum central rod, for this analysis.

To achieve accurate results, a mesh convergence was used on the simulations. To begin, the analysis used the largest possible polygons without losing the fine details in the model geometry. If the polygons were too large for the level of detail, the SOLIDWORKS solver would error, so incrementally stepping down helped find the initial polygon size. Subsequent studies were then done as the mesh size was incrementally decreased. The analysis stopped when there was a negligible difference between subsequent studies. The final mesh parameters used for simulation are shown in Figure 42 below. The global element size was  $\sim 7.74\text{mm}$  and the carousel and lower nozzle mount required smaller meshes due to finer geometric detail, so their element

sizes were  $\sim 3.87\text{mm}$ . After the simulation parameters were defined and the mesh converged, the heat distribution shown in Figure 43 was achieved.

Mesh Details	
Study name	Thermal 1 [-Default-]
Mesh type	Solid Mesh
Mesher Used	Standard mesh
Automatic Transition	Off
Include Mesh Auto Loops	Off
Jacobian points	4 points
Mesh Control	Defined
Element size	7.74359 mm
Tolerance	0.387179 mm
Mesh quality	High
Total nodes	333763
Total elements	208175
Maximum Aspect Ratio	106.59
Percentage of elements with Aspect Ratio < 3	98.5
Percentage of elements with Aspect Ratio > 10	0.048
% of distorted elements (Jacobian)	0
Remesh failed parts with incompatible mesh	Off

MeshControl Details	
Study name	Thermal 1 [-Default-]
Mesh type	Solid Mesh
Entities	2 component(s)
Units	mm
Size	3.87179
Ratio	1.5
Identifier	1

**Figure 42:** General parameters used for the meshing (left) and mesh controls applied specifically to the carousel and lower nozzle mount (right)

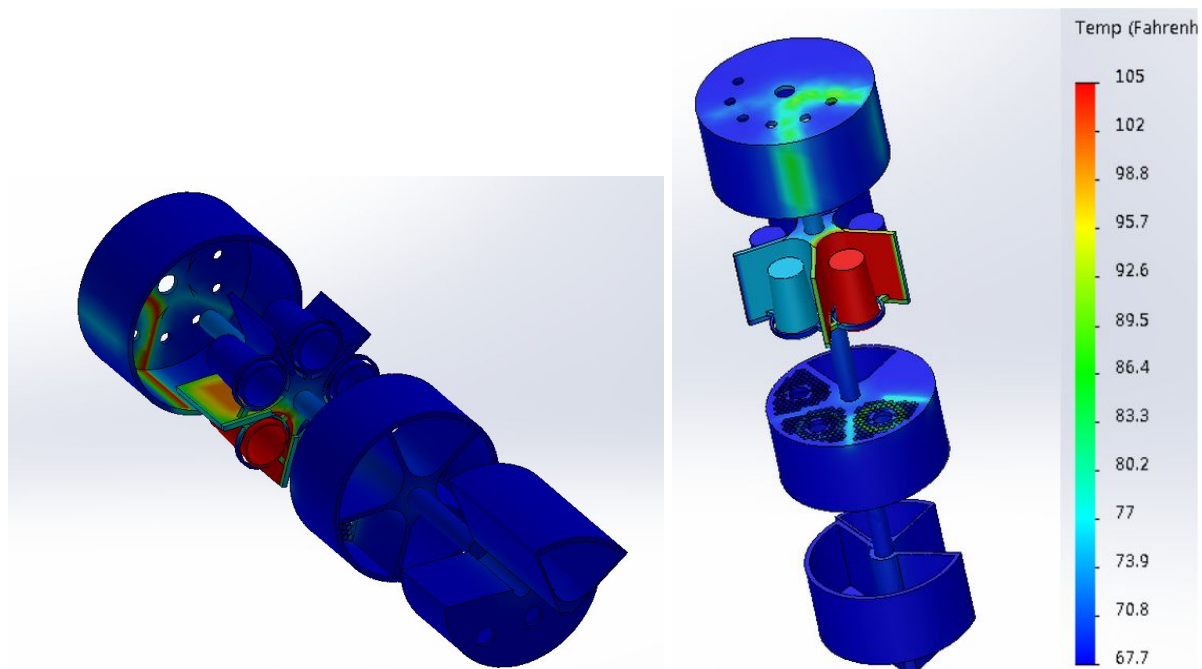

**Figure 43:** Steady state SOLIDWORKS thermal analysis with acrylic components (except for the aluminum center rod) and  $105^{\circ}\text{F}$  water temperature

After modeling the heat dispersion pattern with the steady state analysis, a transient analysis was developed to calculate the time required for a single compartment to reach a steady state from room temperature. The intent was that the transient analysis could help determine cycle length by finding the time to equilibrium. Unfortunately, analyzing the data from the transient analyses proved to not be useful due to the nature of SOLIDWORKS' solver as it was not optimal for a realistic simulation of the design. The program allowed heat sources to be placed on different surfaces, but not in empty spaces. When setting the surface of the cup to be 105°C, there was not an accurate method of simulating the spread of heat from that surface and to the air via convection. There was no way to track the heat of the air in the compartment, which was the primary objective. It again gave an idea of how the heat would spread throughout the machine via conduction, but did not give any concrete information useful to determining cycle length.

### Hand Calculation Approach

After the simulations, the team then turned to calculations and, by hand, used a lumped sum approximation to determine how long the air in the compartment would take to heat up to the temperature of the water spraying the cup. The lumped sum approximation presumes that the rate of heat loss through the acrylic plates is negligible in comparison to the rate of heating the air inside the compartment, and was supported by a calculation of the Biot number. The Biot number was calculated using:

$$Bi = (h * L) / k$$

where h is the convection coefficient, L is the characteristic length (1/2 the thickness if the conductive surface is a plate), and k is the thermal conductivity (~0.20 W/m\*K for acrylic). The scenario was modeled using a 1/4" thick plate made of acrylic and air in free convection, so a value of 5 W/m<sup>2</sup>\*K was used. Altogether, this gave a Biot number of 0.794; a lumped sum approximation requires that Bi < ~0.1 to be relatively accurate, so this approach was valid. The lumped sum approximation uses an equation in the form of:

$$T(t) = T_{cup} + (T_{air, initial} - T_{cup})e^{-t/\tau}$$

where  $T_{cup}$  is the temperature of the surface of the cup,  $T_{air, initial}$  is the initial temperature of the air (~20°C, assuming starting from ambient temperature), t is time, and  $\tau$  is the time constant. First, the time constant was needed, which was found using:

$$\tau = (\rho c V) / (h A)$$

where  $\rho$  is the density of air (~1.15 kg/m<sup>3</sup>), c is the specific heat capacity of air (~1.01 kJ/kg\*K), V is the volume of air, h is the convection coefficient, and A is the surface area of the cup. Using SOLIDWORKS, the total volume of air was found to be 05.78\*10<sup>-4</sup> m<sup>3</sup> and the surface area of the cup was found to be 1.59\*10<sup>-5</sup> m<sup>2</sup>. Therefore, the time constant was found to be 8467 seconds, or 141 minutes. Generally, time to thermal

equilibrium is approximately  $4\tau$ , so to heat *all* of the air in the compartment to the temperature of the surface cup ( $\sim 37.8^\circ\text{C}$ ) would take  $\sim 9.4$  hours. In Figure 44 below, the lumped approximation function is plotted. Due to the exponential nature of the transient heat transfer, an understanding was created of how the air (and thus the compartment) would heat up as the water was sprayed. Due to the nature of the lumped sum approximation, this should be accurate within  $\sim 5\%$ .

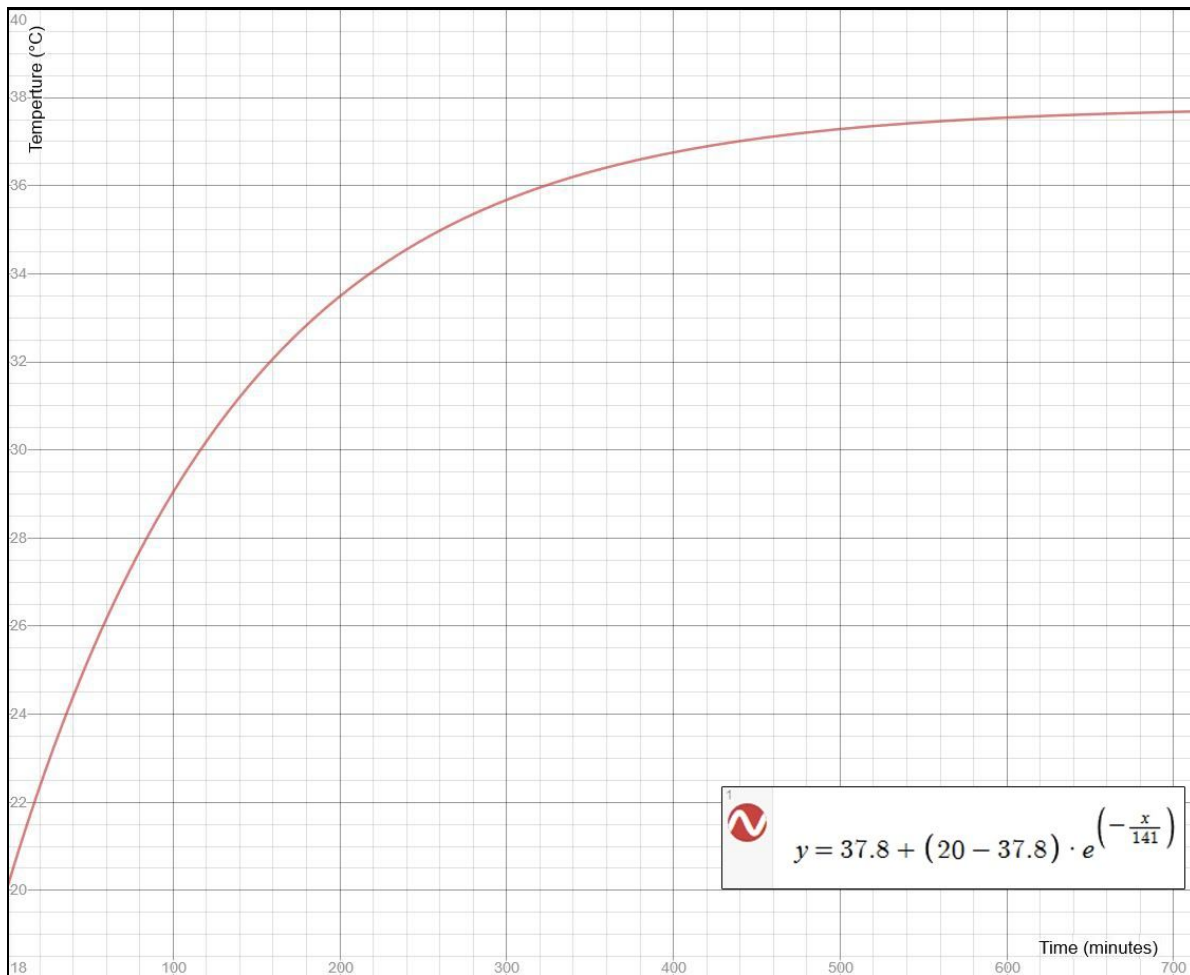

**Figure 44:** A plot of the lumped sum approximation for the machine

The result of 9.4 hours to reach equilibrium seemed unnecessarily lengthy. The team then assessed and determined that as long as the surface of the cup is the temperature that is desired, then the cup is being cleaned; the entire compartment does not need to be at the temperature of the water. Therefore, the thermal analyses and calculations were information that was good to know, but not helpful for determining cycle length.

To determine cycle length, the team looked at two different types of cycles: home dishwasher cycles and commercial dishwasher cycles. Home dishwasher cycles generally

take 1-2 hours, and commercial dishwashers take around 90 seconds typically. This tends to be because commercial dishwashers use better sanitizing chemicals, operate at higher temperatures, and have stronger jets with more pressure and higher flow (Leonard, 2002). The goal was to make the machine more akin to a commercial dishwasher such that lower cycle times could be achieved. The goal was to have a cycle length of 3 minutes or less. Though this was the objective, testing would have to be done to determine ideal cycle lengths. This is discussed more at length in Chapter 7 (Recommendations).

#### 5.1.4 Fluid & Air Delivery

The cleaning system uses water to rinse the cups, water with chlorine to perform a deep cleanse, and compressed air to dry the cups. The design began by focusing on the water delivery. In the scale model, the design was created by first selecting the nozzles. The FDA mandates water delivery for sanitizing between 5 and 30 psi, so this was one of the constraints in selecting a nozzle. Since another goal of the project was sustainability, nozzles were selected that had a low flow rate, but capable of adequate pressure. Ultimately, 4 brass conical nozzles were necessary: one above the cup and one below the cup for both the rinse and deep cleanse cycles. The diameter of the chosen nozzles were  $\frac{1}{4}$ ", this size was chosen to reduce water usage and save space inside the machine. These nozzles require piping with a  $\frac{1}{4}$ " inner diameter. From this, the team worked backwards to a single water source that passes through a regulator. Regulators are common for garden hoses, so a regulator with a  $\frac{3}{4}$ " garden hose input was used. To make this flow meet the required  $\frac{1}{4}$ " inner diameter for each of the four nozzles, a series of tees and reducers was used. The schematic is shown below in Figure 45. The figure shows the water entering from the main line through a regulator that has a  $\frac{3}{4}$ " garden hose input and a  $\frac{1}{2}$ " ID barbed fitting for an output. It then passes through a solenoid, through different tees, reducers, and eventually to the nozzles. A chlorine input is used for the deep cleanse.

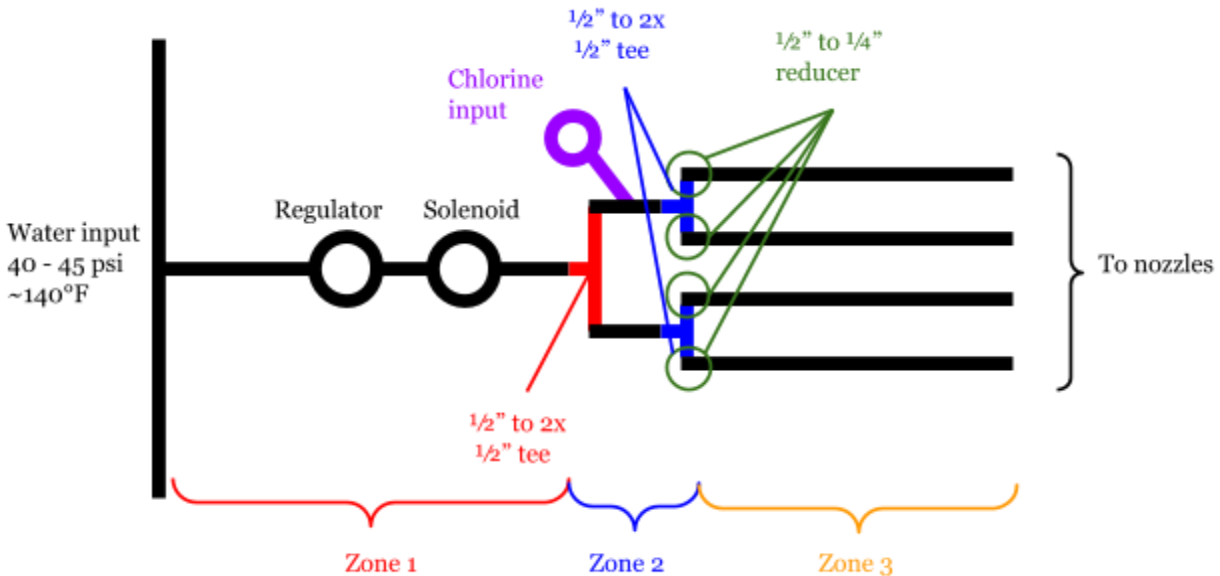

**Figure 45:** Schematic of the piping for the machine

An input from a water main would be connected directly to the input of the regulator. After the regulator, the team decided on using flexible PVC tubing to allow for ease of routing. All fittings were barbed, which eliminated the need for adhesive in assembly with the tubing. The input line for most commercial settings is a line of ~40 psi and ~140°F and the machine was designed to operate based on these constraints. These values appeared adequate for our machine, as the FDA pressure regulations could be met. Additionally, the FDA has a water temperature requirement that varies based on chlorine concentration, though 140°F would be adequate for the concentrations the team was considering of 50-99 mg/L.

Two large variables remained in the delivery of water: heat loss and head loss. The fluid moves quickly through a series of short, well-insulated pipes. It can be assumed that the water hitting the cup would be roughly the temperature of the water in the water main; therefore, heat loss is neglected in this system. This is because the wall thickness and thermal conductivity of the flexible PVC piping acts as nearly perfect insulation for the speeds at which the water travels. However, head loss, or the loss of pressure due to pipe friction and pipe junctions, was not negligible. The major head loss equation is  $h_{Loss, Major} = (f * L * v^2) / (d * 2g)$  where  $f$  is the Darcy friction factor,  $L$  is total length of the pipe,  $v$  is velocity,  $d$  is the hydraulic diameter (ID for circular pipes), and  $g$  is acceleration due to gravity. All the required parameters to compute head loss were known besides the Darcy friction factor.



To find the Darcy friction factor, the piping design was broken into three separate sections as denoted by Figure 45. For each section, the velocity had to be found by dividing the volumetric flow rate by the cross-sectional area of the pipe ID ( $v = Q/A$ ). Once velocity was found, the Reynolds number was calculated using  $Re = (\rho * v * L) / \mu$ , where  $\rho$  is density,  $v$  is average velocity,  $L$  is characteristic length, and  $\mu$  is the dynamic viscosity. This revealed that all three sections experience turbulent flow, and thus to determine the Darcy friction factor, a Moody chart was required. The other parameter necessary to use the Moody chart is the relative roughness, which was found using  $r = k/d$  where  $k$  is the absolute roughness coefficient and  $d$  is the hydraulic diameter. By having relative roughness and Reynolds number, Darcy friction factor could be found, and head loss could be calculated. The full calculation is done in Appendix B.

Two scenarios were calculated: the best case scenario and the worst case scenario. The best case scenario is the shortest pipe that passes through the least bends and valves and does not have the chlorine insert; the worst case scenario is the exact opposite. The head loss (minor + major) in the best case scenario would be ~5.24 psi and the head loss in the worst case scenario would be ~6.53 psi. This meant that the 40 psi from the water main, after losing 5.24 to 6.53 psi due to head loss, would still have plenty of flexibility to deliver within the FDA accepted range of 5 to 30 psi. By tweaking the regulator, the team had a lot of flexibility for testing the water delivery.

As briefly noted above, the wash cycle consists of a solution that uses chlorine as the sanitizing element. Although this prototype does not include the use of chlorine, the concentration of chlorine for future development of this system, to ensure compliance with the Food and Drug Administration regulations, is 100 mg/L. This chlorine is to be delivered to the system in a gaseous state from a small pressurized lecture bottle feeding into the water solution line. This proposed insertion of chlorine is expressed in greater detail in Chapter 7 (Recommendations). The two solenoids positioned on the water and air lines are supplied with 12V which is toggled by 5V relays. The relays are connected to the same Arduino responsible for tracking the wash cycle and transport controls. When a wash cycle begins, the relays are set to open the solenoids if there is a cup in the washing or drying quadrants, and then when a wash cycle ends, the relays close the solenoids.

The air delivery design was a simplistic connection between a pressurized air line and two nozzles. The pressurized line would typically be around 100 psi and a regulator would be used to reduce input air pressure. In the absence of a pressurized air line, a pressurized air tank with a compressor would be installed in the machine. This singular air line would run through a solenoid and then be split into a top and a bottom nozzle. The schematic for the air delivery is shown in Figure 46 below. Instead of conical nozzles, however, a more focused nozzle was chosen. Optimal drying pressure and length of drying cycle are yet to be determined but will be determined by testing.

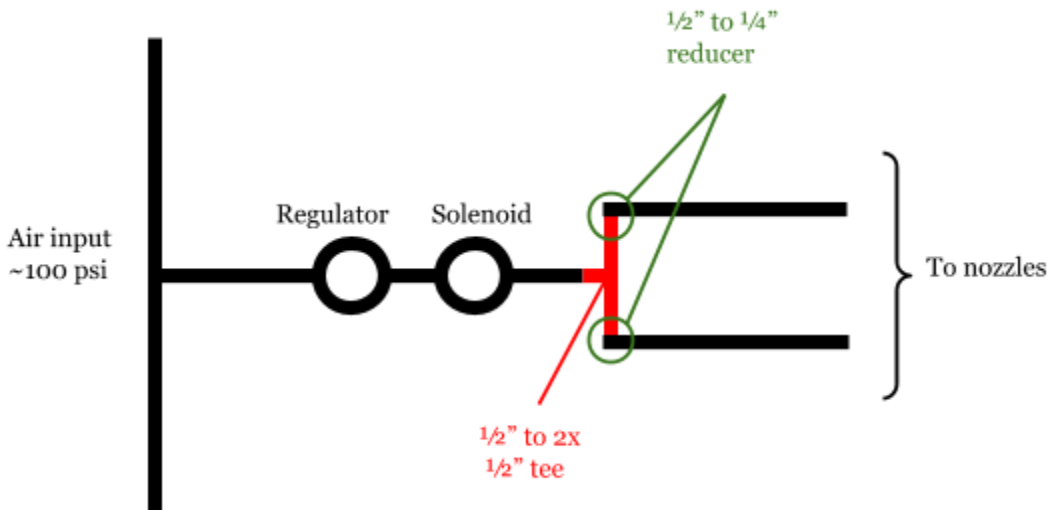

**Figure 46:** *Pressurized air delivery schematic*

### 5.1.5 Electrical Controllers

The electrical system is responsible for supporting mechanical functions of the overall system and receiving programmatic instruction from user and microcontroller timer inputs. It consists of a stepper motor, stepper motor driver, touch screen display, Raspberry Pi, two Arduinos, two solenoids, two relays, and two servo motors. A high level schematic of all electrically connected components can be seen below in Figure 47.

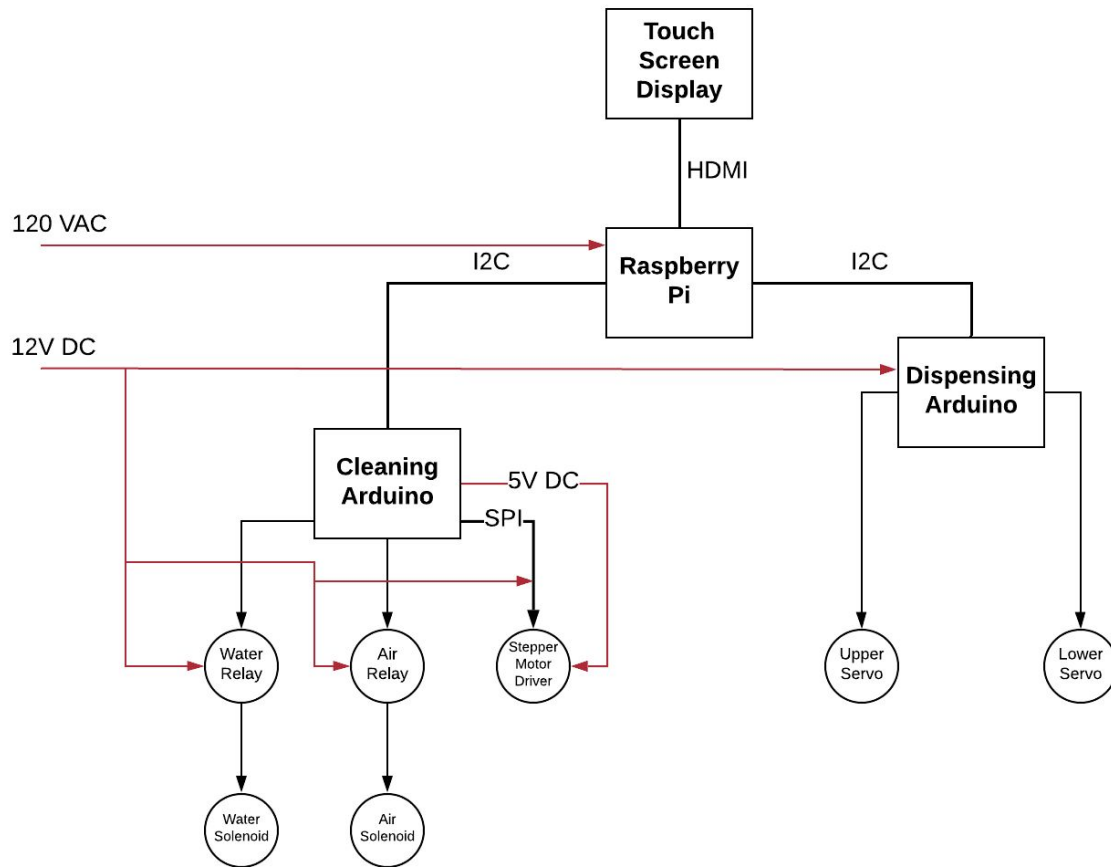

**Figure 47:** Overall system schematic

The various components seen in the diagram were selected based on system requirements, ease of availability, and price. System requirements included those set by the necessary functions of the machine and minimizing extra complexity such as additional voltage levels. Ease of availability focused on available manufacturers and especially shipping time. As noted by the red lines in the figure, the system requires three input voltage levels: 120VAC, 12V DC, and 5V DC. These are used to power the microcontrollers, actuate motors, and provide logic level reference. The 5V DC signal is achieved through an Arduino's 5V output reference pin, 120 VAC is from a wall outlet, and 12V DC is from a wall plug that converts the outlet voltage. The system's high level control is performed by a Raspberry Pi 3 B+ which is connected to the low level controllers, two Arduino Unos, using I<sup>2</sup>C communication. The Raspberry Pi runs the front end user interface and, when appropriate, commands the Arduinos to accomplish controls tasks such as beginning a wash cycle or dispensing a cup.

The transport of cups within the cleaning subsystem is very simple. Cups slide across a mesh floor guided by a ring when the stepper motor receives input from the driver which itself receives commands from an Arduino.

### 5.1.6 Software Engineering

The determination of when the stepper motor should rotate is determined programmatically through signals from the Raspberry Pi. When a user returns a cup through the GUI, the Pi sends a command to the Arduino over the I<sup>2</sup>C bus to begin a wash cycle if one is not already running. Beginning a wash cycle rotates the carousel to the next position (advances system one quadrant), initializes a timer, and activates the fluid and air delivery.

The programmatic aspect of the project is very important to support the system's ease of use, user friendliness, and electrical component control. It walks customers through the process of returning a cup and receiving a cup while also being responsible for triggering the actuation of the necessary electrical components to give customers what they want.

The graphical user interface (GUI) was developed using Python with the guizero and tkinter libraries. It follows the flow described by the statechart diagram pictured below in Figure 48 and an example screen can be seen in Figure 49. Each screen is viewable in Appendix G.

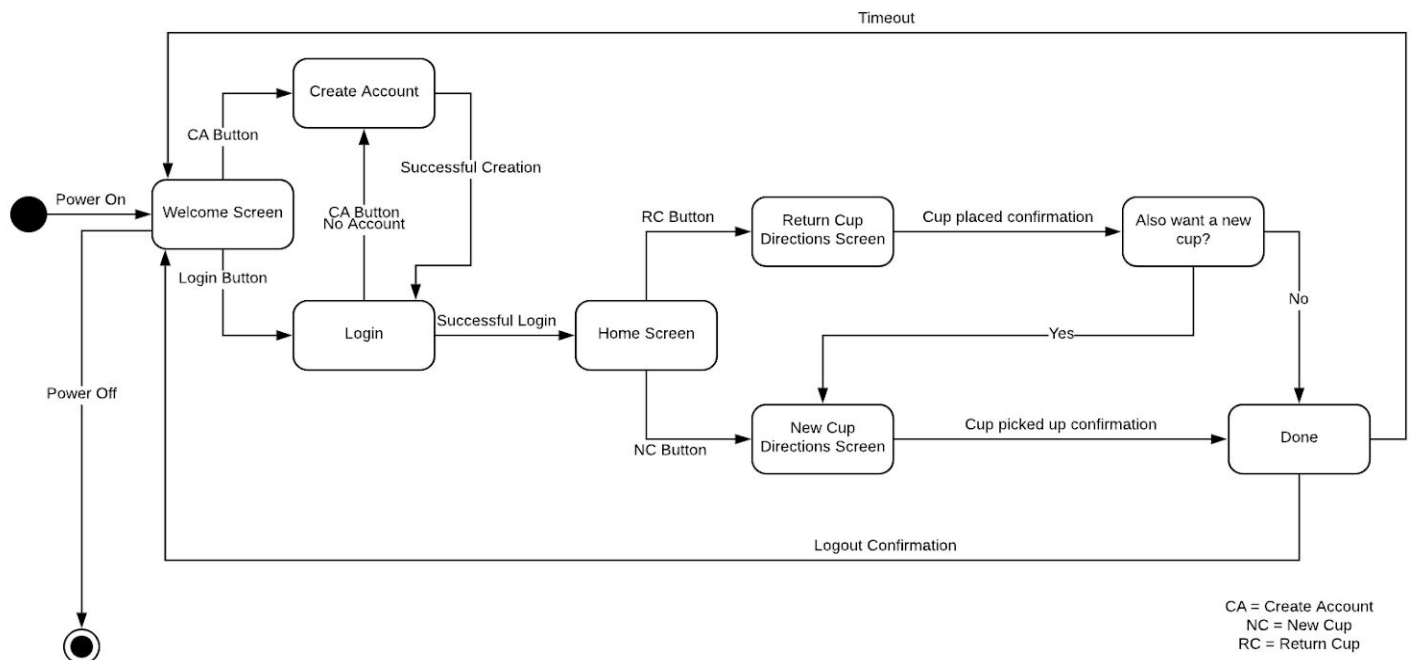

**Figure 48:** A description of the high level flow of the system's GUI

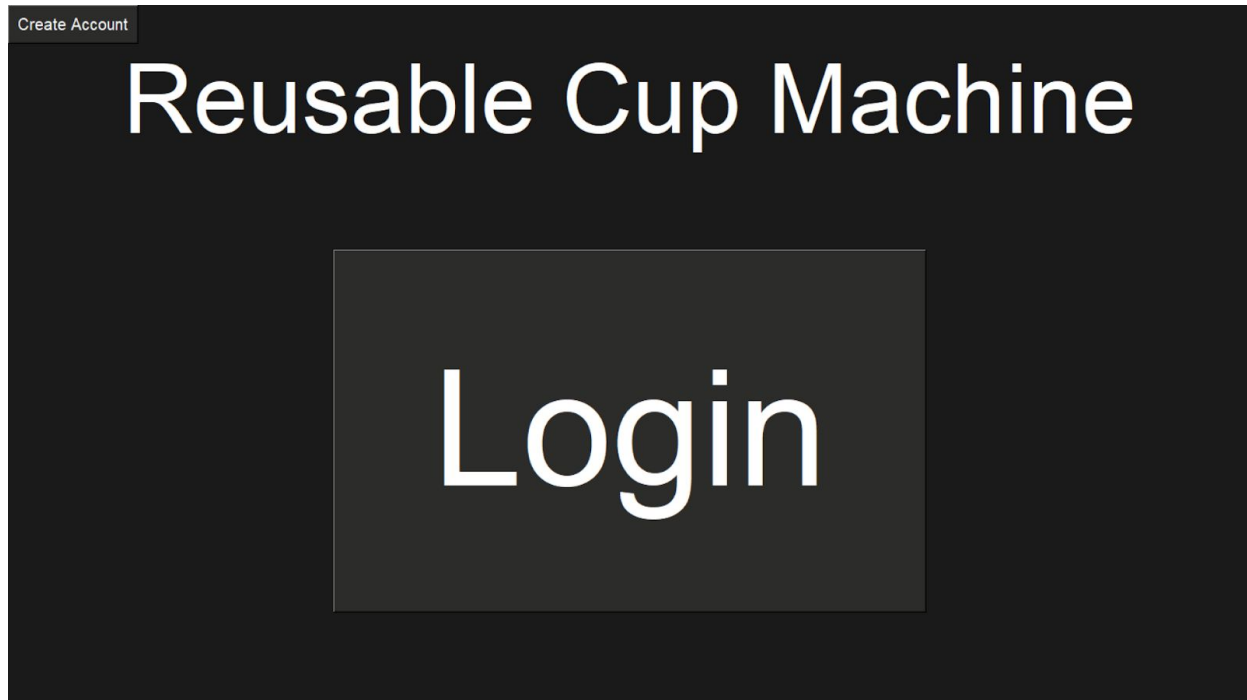
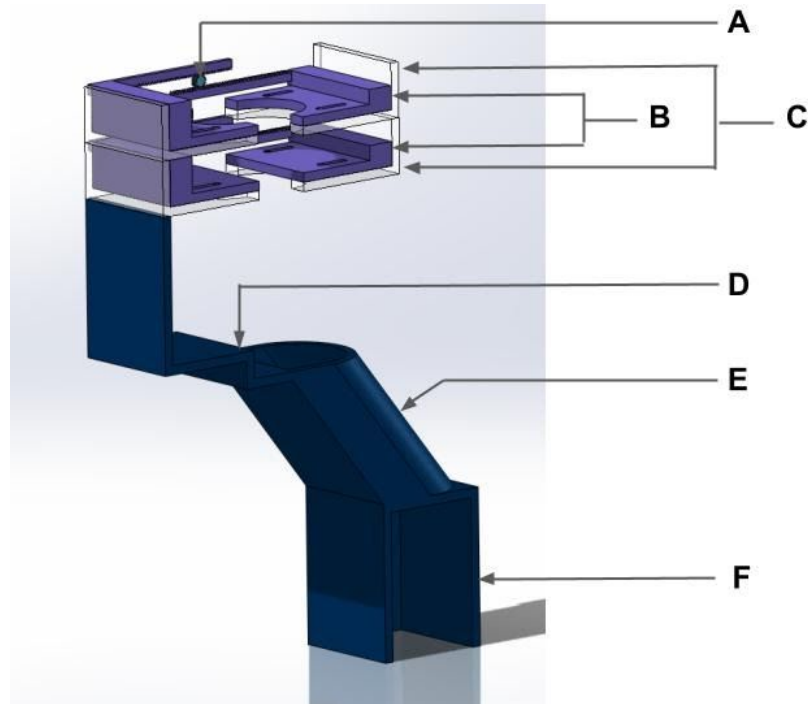

**Figure 49:** *The home screen of the user application*

Communication between the Raspberry Pi and the Arduinos is accomplished using I<sup>2</sup>C from the `smbus` and `Wire` libraries, respectively. Control within the Arduino sketches is accomplished using SPI communication from the `SPI` library, Pololu's `HighPowerStepperDriver` library, the `TimerOne` library, and the `Servo` library. One Arduino monitors the cleaning subsystem by maintaining a model of the positions of cups in each quadrant and running wash cycles appropriately, while the other Arduino controls the dispensing system through two servo motors.

## 5.2 Storage/Dispensing Subsystem

As described in Chapter 4.4, the cup falls into the storage subsystem in stage five of the carousel's cleaning cycle. The storage component funnels cups into a vertical stack with other cups that have completed the wash cycle. The cups are stocked in this location to await distribution just above the dispensing subsystem pictured in Figure 50 below.



**Figure 50:** *Dispensing subsystem*

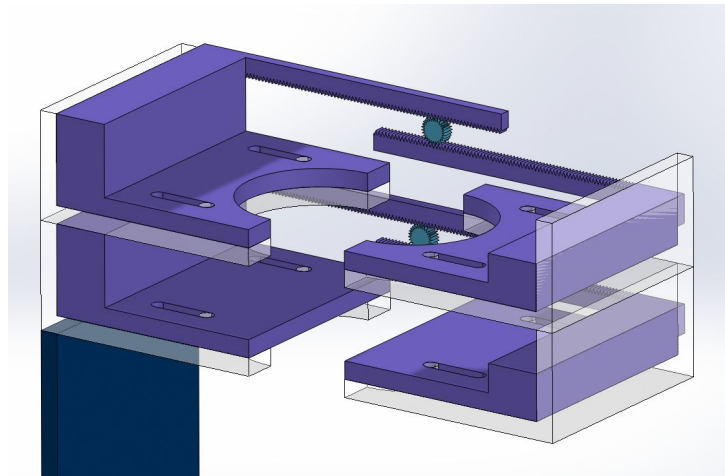

**Figure 51:** *Dispensing rack and pinion system*

Figure 51 depicts the upper portion of this system, oriented with all of the doors open to their maximum clearance. The entire dispensing subsystem is encased by an acrylic box (omitted in Figures 50 and 51 for better visibility), to which four shelves are fixed (Denoted C in Figure 50 above). These shelves support corresponding doors (Denoted B) and have small pins that limit the motion of these doors to follow the path of the racks and pinions. Although not included in the figures above, each of the two pinions (Denoted A, one hidden from view) is attached to a servo motor. As these servos

rotate, the pinions move along their respective racks, translating the rotational motion into linear motion by driving the translation of the doors. The upper doors open first to allow a single cup to fall from the waiting queue above, closing before another cup may pass. This cup rests at the center of the closed lower doors until the servo is activated and allows the cup to fall again. Outside of the gated region, the downward-facing cup comes into contact with a ledge (Denoted D), which flips the cup into a short tube that controls its motion (Denoted E). The tube guides the cup (now upright in adherence to food safety regulations) to its final destination, where the user will retrieve it (Denoted F). A picture of the entirety of the storage system along with the dispensing system is shown in Figure 52 below.

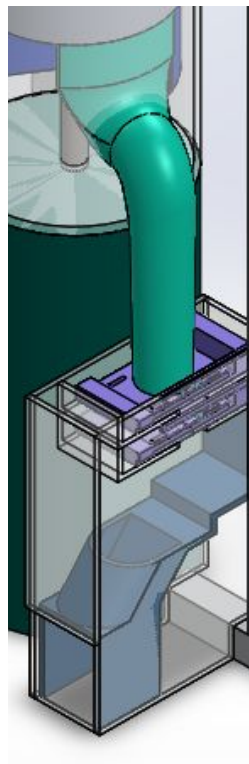
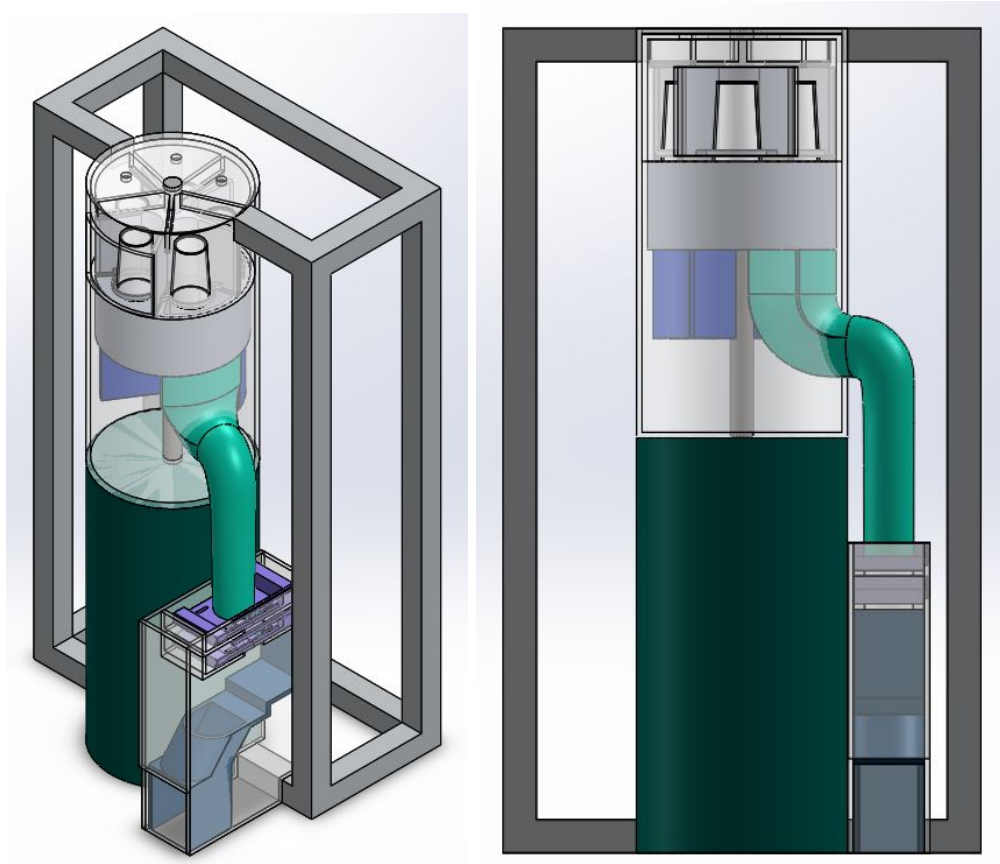

**Figure 52:** *The assembly of the storage system with the dispensing system*

The electronics of the dispensing subsystem are simpler than those utilized in the cleaning subsystem. The only components are two servos used to actuate the platforms for the stack of stored cups. On a cup return request signal from the Raspberry Pi GUI to the dispensing Arduino, the platforms are opened and closed in sequence to allow a single cup down the return chute to the user.

### 5.3 Supporting Structure

The prototype machine is supported and encased by a 46" tall, 22" wide, and 10" deep rectangular enclosure made from extruded t-slot aluminum as shown in Figure 53 below. These dimensions were chosen to allow for enough height to successfully use gravity to flip the cup and enough of a cross-sectional area to contain the subsystems along with the tubing, electrical box, and other supporting pieces. The framing acts as the mounting point for many of the components such as the bearings for the central rod, the stepper motor, the water and air tubing, the water and air solenoids, the water pressure regulator, the main acrylic cylinder used to house the cleaning system, the dispensing system, the user interface, and the electrical box. The main acrylic cylinder is additionally supported by a 10" cube of acrylic (represented by a green tube in Figure 53) so that the dispensing system has enough travel to allow the cups to stack and then flip.



**Figure 53:** Complete assembly of the cleaning system and storage/dispensing system



## Chapter 6: Testing, Prototyping, and Assembly

This section details key testing that influenced design decisions. It also includes the process of prototyping and then assembling the final machine.

### 6.1 Testing

This section details the two major tests that were performed during the development of the machine: a flip test for the dispensing system and a water test for the nozzles.

#### 6.1.1 Dispensing System Cup Flip Test

In order to deliver a sanitary cup to the customer, the cup is flipped such that the opening is face up. To facilitate a repeatable and reliable flip, dimensions had to be found for the height of the drop, the size of the ledge, and the dimensions and angle of the exit tubing. A portion of the experimental process is shown in Figure 54 below. The team used scrap materials from the WPI Makerspace and tried different combinations of dimensions until a consistent result was reached. This setup was then measured and modeled in CAD. The key dimensions were the distance that the cup must fall, the length that the ledge protrudes, the diameter of the tubing, the angle of the tubing, and the position of the tubing.

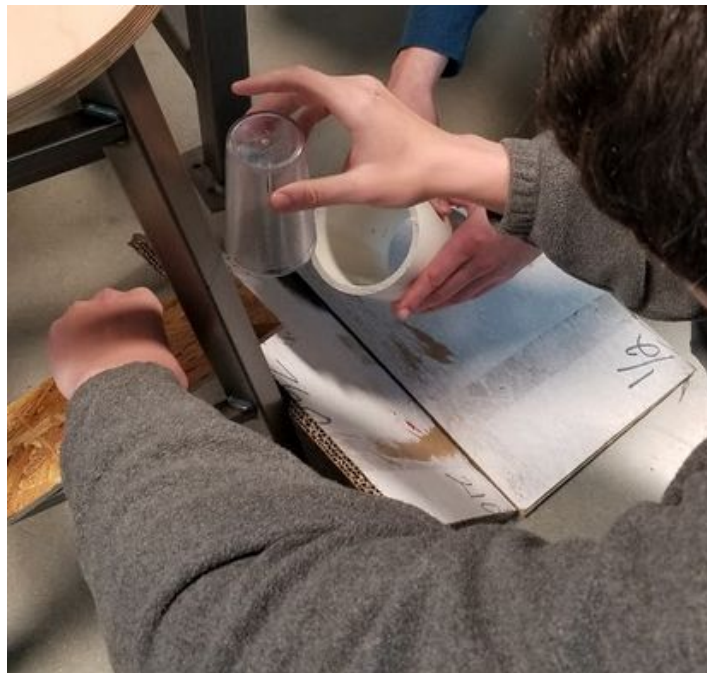

**Figure 54:** *Testing for flipping of the cup after dispensing*

### 6.1.2 Nozzle Pressure and Distance Testing

To meet FDA standards and to guarantee a complete cup cleanse, the water must be sprayed at an optimal water pressure and distance from the cup. Basic testing with the conical nozzles pictured in Figure 55, was performed to determine these parameters. The regulator was adjusted and it was found that water delivery above 20 psi encouraged the cup to fall out of the carousel's holder. Therefore, the team could manipulate the regulator such that water delivery was below 20 psi, but still within FDA regulations. Additionally, the team moved the cup back and forth and determined that the cup needs to sit ~2.25" away from both the top and the bottom nozzles for optimal coverage.



**Figure 55:** *Basic testing of the water pressure regulator with one of the cups*

## 6.2 Prototyping and Assembly

A 9"-OD, 8.75"-ID, 2'-long acrylic cylinder formed the basis of the assembly with all other components constructed around it. A window was cut into the tube to allow users to input the cup and a U-shaped cutout was made for the exit chute that placed cups in storage. A full assembly of the cleaning system is shown in Figure 56 below.

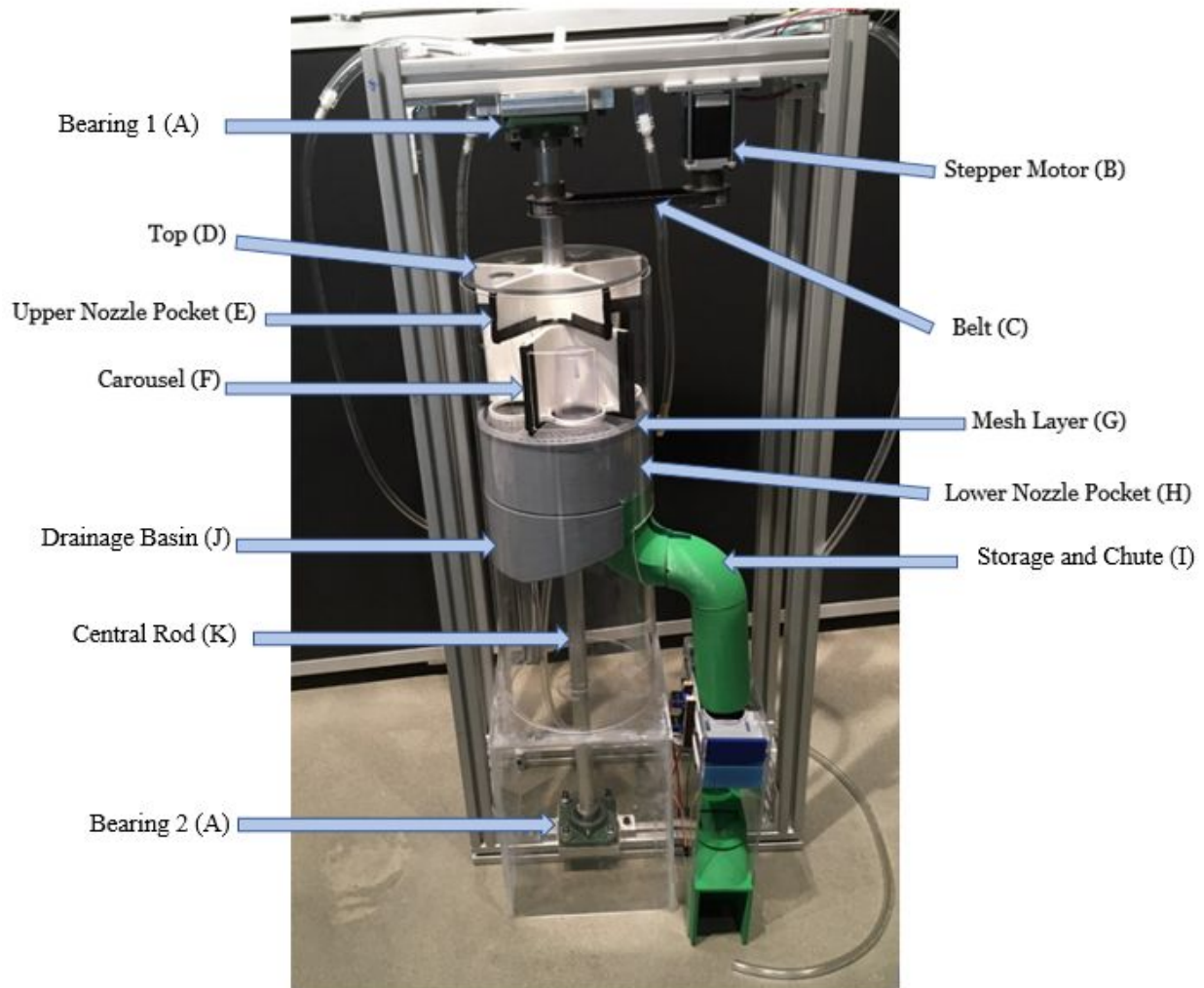
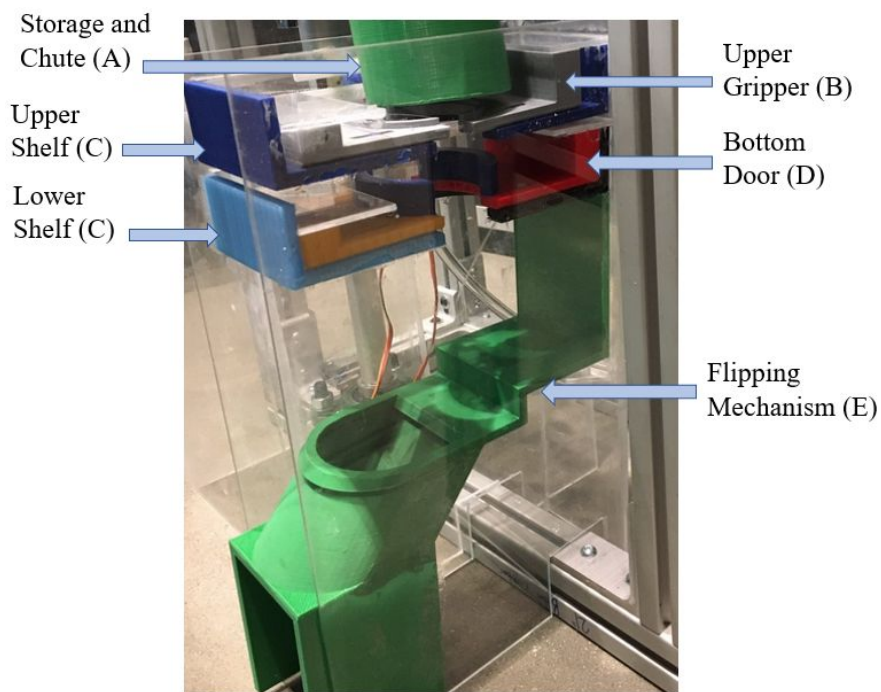

**Figure 56:** *Cleaning Subsystem, consisting of: Bearings (A), Stepper Motor (B), Belt (C), Top (D), Upper Nozzle Pocket (E), Carousel (F), Mesh Layer (G), Lower Nozzle Pocket (H), Drainage Basin and Storage (I), Drainage Basin (J), and Central Rod (K)*

All components centered in the tube (D-H, J) had a clearance hole for the 1" central rod (K) except for the carousel (F) which had an interference fit. These fits helped to ensure the central rod only rotated the carousel as it was actuated by the stepper motor. In addition to the fixation to the rod provided by the interference fit, the carousel is attached to the central rod by two fasteners. The central rod is fixed by two set screws on either end to bearings (A) secured to the surrounding t-slot frame by custom adapting plates. The rotation of the central rod is actuated by a stepper motor (B) which is offset to help avoid water damage to the electrical parts and secured to the frame by a custom mount. This offset is accomplished by a belt (C) which stretches between two cogs; one is mounted to a flat on the central rod by a set screw and the other to a custom adaptor on the 1/4" output shaft of the stepper motor. The custom machining was done with

aluminum, laser cutting was done on acrylic, and many custom parts were 3D printed with PLA. A number of these printed parts were printed multiple times due to tolerancing inconsistencies with the 3D printers and measurement errors. Of the printed parts, those in the carousel fit their OD to the ID of the acrylic tube with a transitional fit to prevent easy movement. Working with adjacent wet and dry compartments, parts needed to properly seal. This was designed into the prints of the upper nozzle pocket (E) and carousel (F) with a groove to allow for rubber stripping to be attached to create watertight pockets. The entire tube rests on a 10" x 10" x 10" acrylic box to allow it to sit at the appropriate height for the dispensing system.

After the cup exits through the storage chute, it enters the storage/dispensing system, as shown in Figure 57 and 58 below.



**Figure 57:** Storage/dispensing subsystem, consisting of: Storage and Chute (A), Upper Gripper (B), Upper and Lower Shelves (C), Bottom Door (D), and the Flipping Mechanism (E)

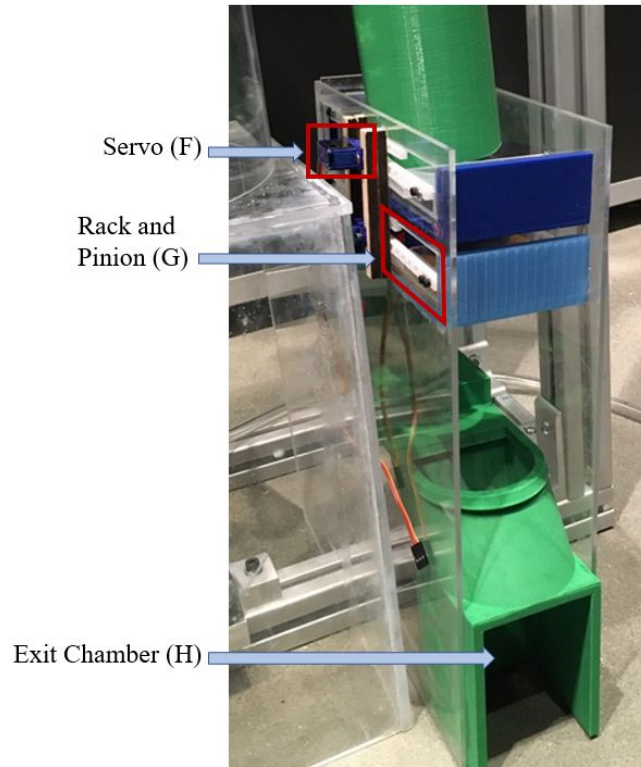

**Figure 58:** *Storage/dispensing subsystem, consisting of: Servo (F), Rack and Pinion (G), and Exit Chamber (H)*

The storage chute (A), upper gripper (B), upper and lower shelves (C), bottom door (D), flipping mechanism (E), and the exit chamber (H) were 3D printed from PLA. These pieces required a few iterations to get the correct sizing. The shelves were secured to the walls of the subsystem by an adhesive and used to guide the two stage drop mechanism. A servo (F) rotates and moves the rack and pinion (G) for each level to allow them to slide open and closed as desired. The first stage is a gripper-esque platform that holds the stack of cups in place while the second stage, a platform, opens to drop the bottom cup. The flipping mechanism (E) and exit chamber (H) are adhered together and to the acrylic walls. The two servos are mounted to balsa wood pieces glued to the acrylic to properly align the output shaft with the racks secured to the sliding platforms in each stage.

The frame itself is made of t-slot aluminum that was cut to specific lengths and fastened together with machined L-brackets. At each corner, three brackets were used to ensure rigidity. The top crossbar was intentionally designed in a way that makes it easy to remove, as it only requires the removal of three t-slot bolts and two set screws in the bearing.

## 6.3 Incomplete Testing and Assembly

As a result of the outbreak of COVID-19 and the resulting campus access restrictions, the team was unable to complete the assembly and testing of the system. The steps that the team deemed necessary to complete the prototype lied in the integration of the electrical systems, hardware, and fluid systems into the machine. The majority of the remaining electrical work for the system was in the layout of the electronics. The layout is important to the system because the distance between mounted components determines the length of the wire necessary to connect them. The team had planned to mount these components to the frame in an organized fashion to minimize unwanted interference between components. The mounted electrical components include the touch screen, power strip, and electrical box. Additional tests are also required to determine how the electronics work together when integrated in the system. These tests are to be done on the integration of the previously mentioned mounted components in addition to control of the stepper motor, solenoids, and relays.

The remaining work in the hardware portion of the system lies heavily in completing the assembly. To create the rotation necessary for the system to function as intended, the rod has to be drilled and tapped for secure connection to the carousel. Additional hardware assembly and testing includes cutting acrylic to fit on the bottom and sides of the frame and iterating the flipping mechanism to improve success rate. Silicone needs to be applied to the different components to create water-tight compartments. Lastly, the team intended to work on the completion of the fluid portion of the system. This includes the installation of an air pressure regulator and solenoids, as well as finishing the layout for the tubing. The team had planned the layout of the tubing to be as direct as possible, this was planned in order to ensure the head loss would not be increased due to unnecessary bends in the piping. The final portion of testing includes testing the wash cycle, the dry cycle, and testing the overall system to ensure successful integration of all sub-systems. The necessary testing and prototyping is described in more detail in Sections 7.1 and 7.3.

## Chapter 7: Conclusions & Recommendations

This chapter contains potential changes and recommendations for the current machine if it were to be rebuilt or redesigned. Additionally, it offers some reflections on the design and manufacturing process.

### 7.1 Recommendations

This subsection details nine specific recommendations made for future development or iterations of this machine.

#### 7.1.1 System Scale

The prototype was scaled down in order to save on the cost of materials. A smaller, 5-ounce cup was used as a reference for the geometry of the current machine in order to achieve the goal of staying in the budget. In the future, a larger, potentially 12-ounce cup should be used as a reference for the geometry of the machine, as the current cup is too small for consumer use. This will result in a larger volume of machine and thus an increase in component price. Sections will have to be taller and wider to accommodate the larger cup, which would result in a taller and wider machine. Likely, the diameter of the cleaning system would need to be closer to 12" instead of 9" and the height would need to be closer to 8" tall instead of 4" tall. The other layers could remain the same height, but would need to have a larger cross-sectional area. Parts of the design process could stay the same such as water and air delivery as the same nozzles could be used. The only change in calculation is a slight difference in head loss due to longer travel in straight sections of pipe, although this is nearly negligible. The stepper could likely be the same, although calculations should be performed to determine this. The dispensing system would require a longer drop distance to flip the cup, so that component would have to be taller also.

#### 7.1.2 Cleaning Agent Incorporation

The current system does not adhere to FDA regulations, as there is no incorporation of a cleaning agent in the wash cycle. As described before, the proposed solution for sanitizing the cups during the washing cycle is a chlorine and water mixture. Chlorine is input in a gaseous state from a pressurized lecture bottle. The lecture bottle would be at a considerably higher pressure than the water, this enabled the gas to enter and mix into the stream almost instantaneously with no back-flow. The flow of gas would be in bursts, controlled by a solenoid. The concentration of the water line must

achieve at least 100 mg of chlorine per liter of solution (100 mg/L) in order to satisfy FDA regulations. Additional calculations are necessary for its incorporation such as the rate at which chlorine gas must enter the water, which would determine how frequently the solenoid must open.

### 7.1.3 Cycle Length Determination

As stated previously, the cycle length needs to be determined. Commercial dishwashers and sanitizers use a cycle length of around 90 seconds, and the machine was built with the intent to emulate this. Ideally, a cycle length below 3 minutes would be achievable, but testing has to be done. The team envisioned using different colored dyes to coat the cup and letting different liquids (such as hot chocolate residue) become stuck on the cup to test cleaning capabilities of different cycle lengths. This determination would be critical, as it would be the slowest process that would limit the throughput of the machine.

### 7.1.4 Cup Cleaning Queue

Due to volume limitations of the cleaning system, there is a maximum of 4 cups in the cleaning area of the system at a time. As a result, the system is likely to back up from irregular patterns in people returning cups to be cleaned. The backup will result in people waiting to input cups into the system or cups being put to the side and never getting cleaned. The team recommends implementing an input storage area for the system to reduce the risk of cup backup in the cleaning section of the machine.

### 7.1.5 Cup Storage

The team recommends an increase in the layout and size of the cup storage system. The current storage system allows a maximum of 5 cups to be stored at a time; it is desired that this can be improved so the system can accommodate larger volumes of cups being input and output from the system. Because the current system uses stacking as its only method of storing cups, the team recommends designing a system that can store multiple adjacent stacks of cups for eventual output.

### 7.1.6 Cup Orientation

The system is designed such that as the cup is dispensed it is flipped over to the upright position. Gravity and 3D printed geometry are used to accomplish this task. This method of flipping the cup is moderately successful, yet doesn't yield the desired results 100% of the time. The "flipping section" of the system fails in two ways: the first of those failures results in the cup not flipping over and falling top down into the output slot, the



second failure of the system results in the cup flipping on its side and becoming stuck inside the system. Both situations are undesirable, but the second failure can result in a backup of the system that only maintenance can fix. Currently, it is a random chance that the cup will flip either successfully or in one of the two unsuccessful manners; because of this, the team recommends that a new and more consistent method of flipping the cups is implemented.

### 7.1.7 Air System Testing

The air system was planned and partially constructed. However, the optimal air pressure, nozzle distance from the cup, and cycle length need to be found for drying the wet cups. This could easily be found via testing.

### 7.1.8 System Application

The currently implemented backend of the application is functional but is very simple. Most notably it does not store user information in between boot sessions. The first step to improve the program would be expanding the capabilities to support database or cloud storage of user information. After this is achieved, then other useful additions to program functionality include tracking statistics on machine usage, power efficiency, water efficiency, and user traffic patterns; and allowing the creation of business accounts to edit system settings or view the previously mentioned trackable statistics. These features would allow for wide scale adoption and usage of the system across an unspecified number of locations as well as providing an improved experience for those who adopt the system.

Additionally, the front end design of the application could be drastically improved. In its current state the user interface is effective, yet plain. It does not scale to different screen sizes effectively which causes the sizing of text and buttons to be clipped by edges of various screens. The color scheme currently in use is fair as it relies on a monochromatic selection of black and grey to achieve some amount of pleasing aesthetics; however, it could be overhauled to include accent colors that allow specific buttons, text boxes, or options to appear more prominent and intuitive for the end user. Any changes should primarily promote user friendliness and ease of use so as to provide the best user experience for customers.

### 7.1.9 System Input and Output Interface

The current system uses gravity as a means of transporting cups from the cleaning section of the system to the output. Due to the stacking system previously described, the amount of vertical space the cup travels from the input of the system to the output is substantial. This vertical distance between the input and output of the cup

proves to be an inconvenience to the user, as it forces them to drop off cups at chest height and pick up new ones at ground level. This difference in height can be particularly problematic for people with disabilities, as some would not be able to access the input or output in the system's current state. As a result, the system in its current state will violate standards set in place by the American Disability Act (ACA), which "prohibits discrimination on the basis of disability by public accommodations and in commercial facilities" (Adata.org).

With the addition of an improved storage system, the team recommends that the machine is analyzed and redesigned to remove empty vertical space and decrease the distance between the input and output. If necessary, a mechanism may be implemented to transport cups to a storage system located at a higher elevation than that current iteration.

## 7.2 Reflections on the Design and Manufacturing Process

Throughout the design process, the team learned many important lessons about designing and building. These lessons include:

- Try to achieve as few moving parts as possible to simplify the controls design.
- Use an iterative design process and utilize each individuals' strengths while designing different components.
- Never settle on a design because it is *good enough*. Keep iterating designs until all team members are satisfied with a final design and can be passionate about it.
- Do not be afraid to seek the advice of professionals, especially in areas outside the team's expertise.
- 3D printing can be an excellent, cheap way to prototype parts and test different ideas.
- Pay careful attention to tolerancing, especially with 3D printing. With 3D printing, also pay attention to infill percentage, supports, and other settings to reduce print time as appropriate.
- Design for assembly such that components can be assembled, deconstructed, and reassembled with ease when changes need to be made.
- Try to avoid adhesives until the parts are *absolutely certainly* ready to go together. Try to opt for fasteners to avoid this mistake as much as possible.
- Take the amount of time that a task *should* take and then double it, at minimum, for an accurate estimate.
- CAD often has issues translating to real life. Examine the CAD model and ask how all components are supported or connected; ensure that the team does not forget anything until the assembly process has begun and exposes the lack of design.

- Be flexible when shipments do not arrive on time or when errors are made in manufacturing or assembly. Find ways to work around roadblocks rather than getting frustrated.
- When performing important tasks, make sure to get a second set of eyes to ensure that the task is being performed correctly.

### 7.3 Unfinished Work

Due to the unexpected pandemic that resulted from COVID-19, the team was not able to complete prototyping and testing of the physical system. The list below documents all of the work the team deems necessary to complete the project, but was unable to accomplish.

- Install air pressure regulator
- Finish assembling water and air tubing layout
- Drill and tap rod to mount carousel
- Mount the carousel
- Get stepper motor moving reliably on command
  - No skipped steps
- Test triggering a solenoid valve from Arduino
- Test wash cycle
- Electrical box mounting
- Mount the power strip
- Mount the solenoids & relay
- Mount touch screen
- Complete wiring connections
- Organize wiring
- Overall system tests
- Acrylic sides and bottoms

### 7.4 Conclusions

As single-use consumer products prevail at the forefront of the global environmental crisis, this project resists the impact of the takeaway beverage industry with the proposal of a reusable cup program. The recommended solution consists of community-wide cup sharing kiosks, each of which has the ability to wash, dry, store, and dispense cups for temporary consumer use.

The design process consisted of multiple iterations over two primary proposal rounds. These designs were assessed with design matrices in order to ensure that an optimal solution was pursued for development. Furthermore, the proposed design

underwent a series of tests that were employed to verify dimensional restraints and enhance the functionality of mechanical, fluid, and thermodynamic components. The machine was classified by three main subsystems—cleaning, storage, and dispensing. The functional requirements of this mechanism are primarily addressed in the cleaning subsystem, thus lending to the focus on this area of the design. A scaled-down proof-of-concept prototype was manufactured to demonstrate the intended functionality of this model. Development consisted of various production methods, including, but not limited to: rapid prototyping, hand milling, dremeling, and soldering.

Although this prototype is not physically finalized due to complications caused by the COVID-19 pandemic outbreak, the proposed and assembled design parameters exemplify a substantial foundation for future project work. The standing assembly components uphold the intended functional requirements, and, along with the recommendations offered above, will counsel the team's successors to successful implementation of this program on and around the Worcester Polytechnic Institute campus community.

## References

Abate, C. J. (2018, September 25). What is a microcontroller? Retrieved from: <https://www.elektormagazine.com/news/what-is-a-microcontroller>

Auslander, D. M., Lemkin, M., Huang, A. (1993, 23 July). Control of Complex Mechanical Systems. *IFAC Proceedings Volumes, vol 26 (2)*: 741-744. DOI: [https://doi.org/10.1016/S1474-6670\(17\)48368-6](https://doi.org/10.1016/S1474-6670(17)48368-6).

Emmel, J. A. (2013, February). Dishwashing and Water Conservation. Retrieved from <https://www.joe.org/joe/2003february/rb3.php>.

Engineer's Edge. (2008). Convective Heat Transfer Coefficient Chart. Retrieved from: [https://www.engineersedge.com/heat\\_transfer/convective\\_heat\\_transfer\\_coefficients\\_13378.htm](https://www.engineersedge.com/heat_transfer/convective_heat_transfer_coefficients_13378.htm)

Engineering ToolBox. (2004). Darcy-Weisbach Pressure and Major Head Loss Equation. Retrieved from: [https://www.engineeringtoolbox.com/darcy-weisbach-equation-d\\_646.html](https://www.engineeringtoolbox.com/darcy-weisbach-equation-d_646.html)

Engineering ToolBox. (2004). Minor or Dynamic Loss Coefficients for Pipe or Tube System Components. Retrieved from: [https://www.engineeringtoolbox.com/minor-loss-coefficients-pipes-d\\_626.html](https://www.engineeringtoolbox.com/minor-loss-coefficients-pipes-d_626.html)

Engineering ToolBox. (2003). Reynolds Number. Retrieved from: [https://www.engineeringtoolbox.com/reynolds-number-d\\_237.html](https://www.engineeringtoolbox.com/reynolds-number-d_237.html)

Engineering ToolBox. (2003). Roughness & Surface Coefficients. Retrieved from: [https://www.engineeringtoolbox.com/surface-roughness-ventilation-ducts-d\\_209.html](https://www.engineeringtoolbox.com/surface-roughness-ventilation-ducts-d_209.html)

Engineering ToolBox. (2003). Thermal Conductivity of selected Materials and Gases. Retrieved from: [https://www.engineeringtoolbox.com/thermal-conductivity-d\\_429.html](https://www.engineeringtoolbox.com/thermal-conductivity-d_429.html)

Engineering ToolBox. (2004). Water - Dynamic and Kinematic Viscosity. Retrieved from: [https://www.engineeringtoolbox.com/water-dynamic-kinematic-viscosity-d\\_596.html](https://www.engineeringtoolbox.com/water-dynamic-kinematic-viscosity-d_596.html)

Evans, D. (2018, February 1). Cups: Single Use (Disposable) vs. Reusable - An Honest Comparison. Retrieved from <https://terngoods.com/blogs/learn/cups-single-use-disposable-vs-reusable-an-honest-comparison>.

Fitzpatrick, J. (2017, October 30). Everything you need to know about getting started with the Raspberry Pi. Retrieved from: <https://www.howtogeek.com/138281/the-htg-guide-to-getting-started-with-raspberry-pi/>

Fountain Machines Market Size is Determined to Exceed \$US 2540 million by 2024. (2019, April 4). Retrieved from: <https://www.marketwatch.com/press-release/fountain-machines-market-size-is-determined-to-exceed-us-2540-million-by-2024-2019-04-04>

GPIO. (2019). Retrieved from: <https://www.raspberrypi.org/documentation/usage/gpio/>

Great Pacific Garbage Patch. (2019). Retrieved from: <https://www.nationalgeographic.org/encyclopedia/great-pacific-garbage-patch/>

Gribkoff, E. (2013). Applications of deterministic finite automata. Retrieved from <https://web.cs.ucdavis.edu/~rogaway/classes/120/spring13/eric-dfa.pdf>

Hakkinen, T. (2010, September). Environmental Impacts of Disposable Cups with Special Focus on the Effect of Material Choices and End of Life. Retrieved from <https://www.sciencedirect.com/science/article/pii/S0959652610001782>.

How it works: mugshare - a better way to coffee. (OAD). Retrieved from <https://www.mugshare.ca/how-it-works>

Karnopp, D. C., Margolis, D. L, Rosenberg, R. C. (2012). *System Dynamics: Modeling, Simulation, and Control of Mechatronic Systems*. Hoboken, NJ: John Wiley & Sons, Inc.

Keller, R. M. (2001, September). Computer science: Abstraction to implementation. Retrieved from: <https://www.cs.hmc.edu/~keller/cs60book/%20%20%20All.pdf>

Kirk, D.E. (2004). *Optimal Control Theory: An Introduction*. Mineola, NY: Dover Publications, Inc.

Leonard, W. (2002, February 5). Commercial Dishwashers in the Home. Retrieved from:  
<https://www.chowhound.com/post/commercial-dishwashers-home-long-idiosyncratic-post-288425>

Liu, M. (2018, March 23). Great Pacific Garbage Patch now three times the size of France. Retrieved from:  
<https://www.cnn.com/2018/03/23/world/plastic-great-pacific-garbage-patch-intl/index.html>

Mealy, George H. (1955). A Method for Synthesizing Sequential Circuits. Bell System Technical Journal. pp. 1045–1079.

Moore, E. F. (1956). Gedanken-experiments on sequential machines. Automata studies, 34, 129-153.

Moore, K., & Gupta, D. Finite state machines. Retrieved from  
<https://brilliant.org/wiki/finite-state-machines/>

Morales, M. (2016, March 8). Why you're still not bringing a reusable mug for your daily coffee. Retrieved from:  
<https://www.sightline.org/2016/03/08/why-youre-still-not-bringing-a-reusable-mug-for-your-daily-coffee/>

Parrish, K. (2017, November 26). Arduino vs. Raspberry Pi. Retrieved from:  
<https://www.digitaltrends.com/computing/arduino-vs-raspberry-pi/>

Radu, S. (2019, February 10). Climate Change Is the Greatest Global Threat Right Now, Survey Says. Retrieved from  
<https://www.usnews.com/news/best-countries/articles/2019-02-10/climate-change-is-seen-as-greatest-global-threats-survey-finds>.

Tawil, Y. (2016, July 1). Understanding Arduino UNO hardware design. Retrieved from:

<https://www.allaboutcircuits.com/technical-articles/understanding-arduino-uno-hardware-design/>

United States, Congress, U.S. Food and Drug Administration. "FDA.gov." *FDA.gov*, FDA, 2017. <https://www.fda.gov/media/110822/download>

Vandoren, V. (2014, August 28). Open- vs. closed-loop control. Retrieved from: <https://www.controleng.com/articles/open-vs-closed-loop-control/>

VESSEL. (2020). Retrieved from <https://vesselworks.org/>

What is the Americans with Disabilities Act (ADA)? (2020). Retrieved from <https://adata.org/learn-about-ada>

What is Arduino?. (2019). Retrieved from: <https://www.arduino.cc/en/guide/introduction>



## Appendix A - Design criteria for our initial design process with explanation and weighting.

**Table 2:** Design criteria explanation for initial design

<b>Design Criteria</b>	<b>Description</b>	<b>Rating (1-5)</b>	<b>Weight (1-3)</b>
Size	How large is this subsystem? Is it compact?	1: Design is incredibly large 5: Design is very compact	2
Accessibility	How easy is it to access the system and clean any residue buildup?	1: Components are impossible or very difficult to access 5: Components are incredibly easy to access and clean	1
Energy	How much energy is needed for the system?	1: Requires lots of energy 5: Requires minimal energy	2
Simplicity	How simple is the overall design? Would it be easy to build?	1: Design is incredibly complex and requires lots of effort to build 5: Design is very simple and would be easy to build	3
Water and chemical use	How much water and chemicals does this design need to function properly?	1: Requires a large amount of water and chemicals 5: Requires minimal water and chemicals	2
Water Delivery	How well does the system deliver the water? How complex is the design for the cleaning process?	1: System delivers the water poorly, requires very complex considerations for how to clean 5: System delivers water well, and has a simple cleaning process	3
Drainage efficiency	How easily does the system drain dirty water? Are there any spills or drips?	1: The system drains water poorly, there is water pooling and buildup 5: The system drains water very easily and effectively	2
Water-	Is the design water-tight?	1: Design is not water-tight or	3

tightness	How easily could it be made water-tight?	requires lots of effort to become water tight 5: Design could easily be made water-tight	
Drying Efficiency	How well does the system dry the cups? Does it hit all sides, edges, and have the cup leaving dry? Does it require a lot of effort to dry the cup properly?	1: Cup is not dried well and/or very lengthy measures are needed to dry the cup properly 5: Cup is dried perfectly and the design dries with ease	2

## Appendix B - Head Loss Calculation Process

To accomplish the head loss calculations, the team began by selecting nozzles and the pipe diameters for the PVC tubing. 4 conical spray nozzles were selected that require 2.8 gallons/minute ( $0.000176 \text{ m}^3/\text{s}$ ). The piping design can be seen in Figure 59 below. Based on the design, the water delivery process was broken into three separate subsections:

1. Input piping with  $\frac{1}{2}$ " ID (1 tube)
2. Piping after the first tee, still with  $\frac{1}{2}$ " ID (2 tubes)
3. Piping after the second tees with reducers,  $\frac{1}{4}$ " ID (4 tubes)

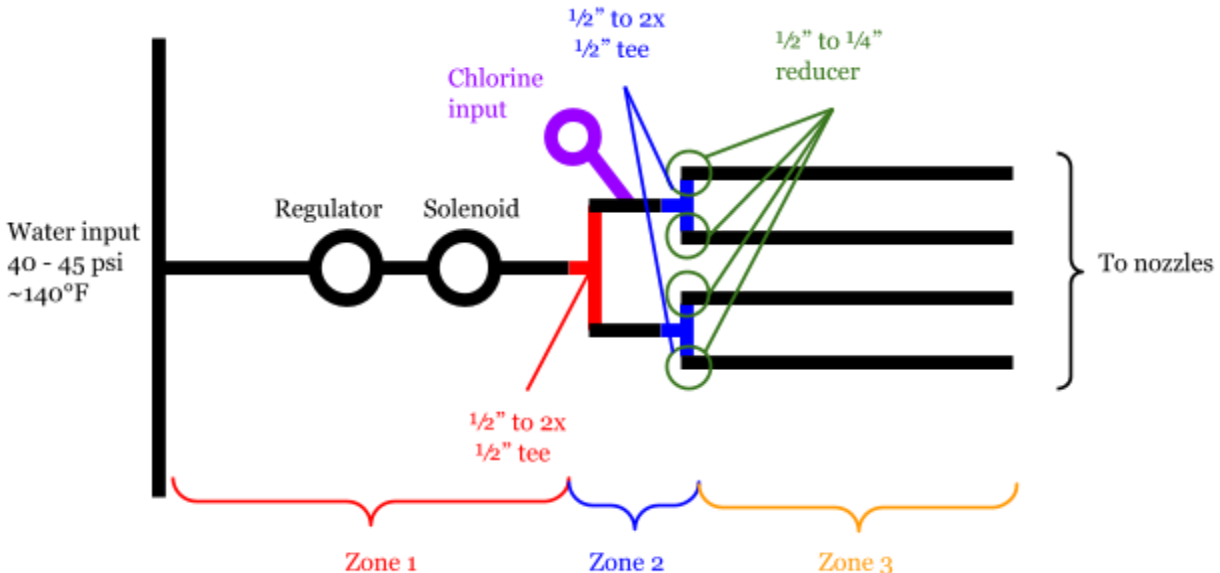

**Figure 59:** Piping design diagram with each of the three zones shown. Red marks Zone 1, orange marks zone 2, and zone 3 is all piping after the second set of tees and reducers

Since each of these sections has a different cross-sectional area, the velocity in each zone had to be found. Important to note is that constant flow rate at the necessary flow rate for the nozzles is assumed. Water is also assumed to be a Newtonian, incompressible fluid. Thus, the flow rate equation

$$Q = A * v \rightarrow v = Q / A$$

Can be used where Q is volumetric flow rate, A is cross-sectional area, and v is fluid velocity. This gave the results below:

**Table 3:** Volumetric flow rate at each zone

Zone	Velocity (m/s)
1	1.39
2	0.697
3	1.39

Then, the Reynolds number for each of the three sections had to be found, which was accomplished using the following equation:

$$Re = (\rho * v * L) / \mu$$

In this instance,  $\rho$  is density (1000 kg/m<sup>3</sup> for water),  $v$  is average velocity,  $L$  is characteristic length (which is the ID for circular pipes), and  $\mu$  is the dynamic viscosity (which is conservatively  $\sim 0.00105$  Pa\*s for water at 100°F). Given that all required variables were known, the following result was calculated:

**Table 4:** Reynolds number at each zone

Zone	Re	Turbulent?
1	16784	Yes
2	8420	Yes
3	8394	Yes

Since turbulent flows occur at  $Re > \sim 4000$ , all three zones were easily classified as having turbulent flows. Since there were turbulent flows, a Moody chart would be necessary to find the Darcy friction factor and ultimately calculate head loss. To use a Moody chart, relative roughness,  $r$ , needed to be calculated using

$$r = k / d$$

where  $k$  is the absolute roughness coefficient ( $\sim 0.00425 * 10^{-3}$  m for PVC), and  $d$  is the hydraulic diameter (which is just the diameter for circular pipes). Using this, the relative roughnesses of each zone was calculated.

**Table 5:** Relative roughness at each zone

Zone	Relative Roughness (r)
1	0.000335
2	0.000335
3	0.000669

By finding both the relative roughness and the Reynolds number, a Moody chart was then examined to find the accompanying Darcy friction factor.

**Table 6:** Darcy friction factor at each zone

Zone	Darcy friction factor
1	0.03
2	0.033
3	0.035

By using these values, major head loss (head loss due to friction in the pipes) was calculated using the following equation:

$$h_{Loss, Major} = (f * L * v^2) / (d * 2g)$$

where f is the Darcy friction factor, L is total length of the pipe, v is velocity, d is the hydraulic diameter (ID for circular pipes), and g is acceleration due to gravity. However, minor head loss in our tees, reducers, solenoids, regulator, and bends in the pipe also had to be accounted for. The “equivalent length” method was used, in which all of these components are converted to an equal length of straight pipe (such as the values shown in Figure 6o) and plugged into the major head loss equation along with the actual length of the pipe. Equivalent lengths for components were taken from Engineering Toolbox.

Equivalent Length of Straight Pipe for Valves and Fittings (m)												
Screwed Fittings		Pipe Size										
		1/4	3/8	1/2	3/4	1	1 1/4	1 1/2	2	2 1/2	3	4
Elbows	Regular 90 deg	0.7	0.9	1.1	1.3	1.6	2.0	2.3	2.6	2.8	3.4	4.0
	Long radius 90 deg	0.5	0.6	0.7	0.7	0.8	1.0	1.0	1.1	1.1	1.2	1.4
	Regular 45 deg	0.1	0.2	0.2	0.3	0.4	0.5	0.6	0.8	1.0	1.2	1.7
Tees	Line flow	0.2	0.4	0.5	0.7	1.0	1.4	1.7	2.3	2.8	3.7	5.2
	Branch flow	0.7	1.1	1.3	1.6	2.0	2.7	3.0	3.7	4.0	5.2	6.4
Return Bends	Regular 180 deg	0.7	0.9	1.1	1.3	1.6	2.0	2.3	2.6	2.8	3.4	4.0
Valves	Globe	6.4	6.7	6.7	7.3	8.8	11.3	12.8	16.5	18.9	24.1	33.6
	Gate	0.1	0.1	0.2	0.2	0.3	0.3	0.4	0.5	0.5	0.6	0.8
	Angle	3.9	4.6	4.6	4.6	5.2	5.5	5.5	5.5	5.5	5.5	5.5
	Swing Check	2.2	2.2	2.4	2.7	3.4	4.0	4.6	5.8	6.7	8.2	11.6
Strainer		1.4	1.5	2.0	2.3	5.5	6.1	8.2	8.8	10.4	12.8	

**Figure 60:** Equivalent lengths of fittings (EngineeringToolbox, 2003).

Two calculations were performed in this section: one for the best case scenario where the pipe is the shortest, passes through the least bends and valves, and does not have the chlorine insert, and one for the worst case scenario which is the exact opposite. The values were plugged in and a conservative length of 1 meter of pipe in each section was used along with the equivalent lengths for calculations.

**Table 7:** Best and worst case scenario at each zone

Zone	Best Case (m)	Worst Case (m)
1	1.84	1.84
2	0.148	0.180
3	1.19	1.57

The final step was to find the change in pressure using a modified version of Bernoulli's equation:

$$\Delta P = \rho * g * h$$

Here,  $\Delta P$  is the change in pressure,  $\rho$  is the density (1000 kg/m<sup>3</sup> for water),  $g$  is acceleration due to gravity, and  $h$  is the change in height, which includes the head loss. Therefore, the following results were achieved:

**Table 8:** Volumetric flow rate at each zone

Zone	Best Case (psi)	Worst Case (psi)
1	2.61	2.61
2	0.211	0.257
3	2.41	3.66
<b>TOTAL</b>	<b>5.24</b>	<b>6.53</b>

\*Note that these calculations were done relatively conservatively such that the maximum potential pressure loss could be seen. Testing should be done to verify these calculations.

## Appendix C - Matlab Stepper Motor Torque Calculations

```

angular_rotation_desired = 6; % rpm
rise_time_desired = .1; % sec

% From SOLIDWORKS Assembly Mass Properties [X, Y, Z]
moi = [4415058.47; 100042230.65; 100046098.14]; % g*mm^2
sf = 3; % safety factor

ard_to_radians = angular_rotation_desired * (2*pi/60) % rad/sec

derived_acceleration = ard_to_radians/rise_time_desired % rad/sec^2

convert_moi = moi/1E9 % kg/m^2

% z-axis torque = moment of inertia * angular acceleration
Torque = convert_moi(3)*derived_acceleration
SFTorque = Torque*sf

```

```
ard_to_radians =
```

```
    0.6283
```

```
derived_acceleration =
```

```
    6.2832
```

```
convert_moi =
```

```
    0.0044
```

```
    0.1000
```

```
    0.1000
```



Torque =

0.6286

SFTorque =

1.8858

*Published with MATLAB® R2018b*

## Appendix D - Github Gist Links for Code Files

### Python

GUI - <https://gist.github.com/owencsmith/075bb15127439fd392bdbddfe3155747>

I2C Communication -

<https://gist.github.com/owencsmith/1c2f62cc8c3af54050d81645cbb33d69>

### Arduino

Cleaning - <https://gist.github.com/owencsmith/b41b4b29896b4a2116259c67de1d76of>

Dispensing -

<https://gist.github.com/owencsmith/9ad17414d294096986c9afa6b99bebe1>

## Appendix E - Bean Counter Interview

9/24/2019

Our goal: Determine stakeholder needs for the machine and the associated program.  
The world uses 500 billion plastic cups a year which comes out to about 1.4 billion cups a day.

How do you clean your cups currently?

Standard dishwasher with racks and door that closes up

How many reusable cups do you use in a day and how many take-away cups do you use in a day?

Substantially more disposable cups; 1500 a week; 300-400 reusable of those

What environmentally sustainable systems do you have in place currently?

Customers can come in with their own cups; disposable cups are 100% recycled paper, one of the other stores has paper straws.

What would you think of people bringing their own cup to your business?

See above response; they already can.

Approximately how many people bring their own cups currently?

Not that many, it is not really promoted, 2%

Would you offer discounts to people who brought their own cups?

No discount would be given.

What is the monetary breakdown of a cup of coffee (revenue, expenses, etc)?

Around 6-7 cents per cup, lid is 7.2 cents.

Would you consider taking part in a cup sharing program with other local coffee shops?

Yeah.

Our idea could possibly involve a cup-sharing program where a kiosk would be stationed in your shop. This kiosk would clean and restock cups for coffee. Would you want to adopt this sort of program?

yeah

If this machine did exist, what would you want it to do? Our idea is to make it dispense and collect cups and clean them in between. The machine could range in size from a countertop size to the size of a vending machine, depending on how many cups are stored. Could you suggest any changes or improvements to our process/design? Hold, wash, something you don't have to maintain.

Would it wash them individually?? Or in batches??

Envisions something that looks like a redbox, not the size of a snapple refrigerator in the store.

Would you see our system as a viable addition to your company?

Don't know about the business side of it, helps that it is effective in other places, more effective in university with multiple dining centers, using id to make sure they return it, at end of year

Other businesses who have taken part in similar programs have received increased visibility through news reports.

## Appendix F - WPI Food Services Employee

9/25/2019

Our goal: Determine stakeholder needs for the machine and the associated program.  
The world uses 500 billion plastic cups a year which comes out to about 1.4 billion cups a day.

How do you clean your cups currently?

Reusable containers - dish machine/dishwashers conveyor belt style

Ozzy - collects/dispenses not clean

How many reusable cups do you use in a day and how many take-away cups do you use in a day?

Considered a reusable cup with the container - take the process of being green in steps

What environmentally sustainable systems do you have in place currently?

Reusable containers ~ 100/120 a day

Cup is the next step - biggest concern is counterspace/electrical/plumbing/size

Napkins/utensils are compostable

Eliminated straws in morgan, cc working on eliminating straws completely (paper

What would you think of people bringing their own cup to your business?

Issues with health rules - standardized

Are there other board of health concerns?

Cleaning - high temp/sanitizer (180 degrees)

Get audited twice a year

Would you offer discounts to people who brought their own cups?

Potentially at CC/planet smoothie/library cafe - good incentive

Would you consider taking part in a cup sharing program with local coffee shops?

Probably just on-campus but that is a bit beyond her scope

If this machine did exist, what would you want it to do? Our idea is to make it dispense and collect cups and clean them in between. The machine could range in size from a

countertop size to the size of a vending machine, depending on how many cups are stored. Could you suggest any changes or improvements to our process/design?  
A freestanding kiosk would be better than a countertop system.

Would you see our system as a viable addition to your company?  
A lot of places are going sustainable so it would be a good addition.

# Appendix G - User Interface Screens

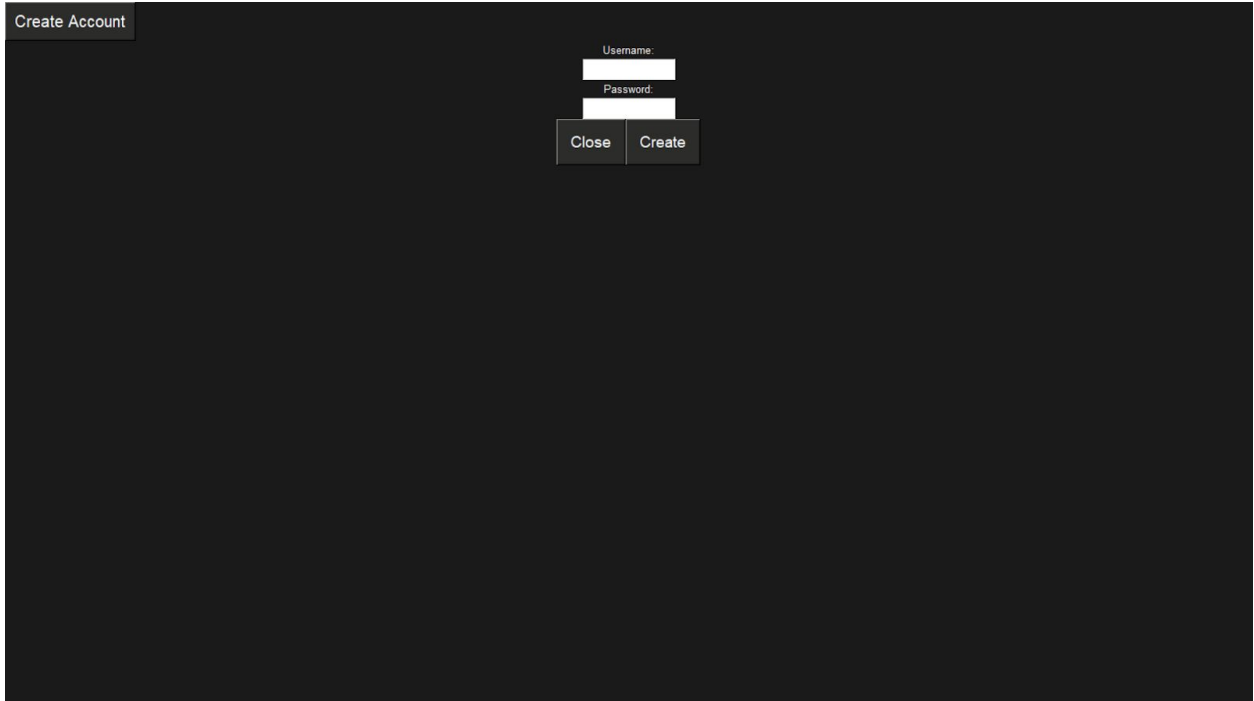
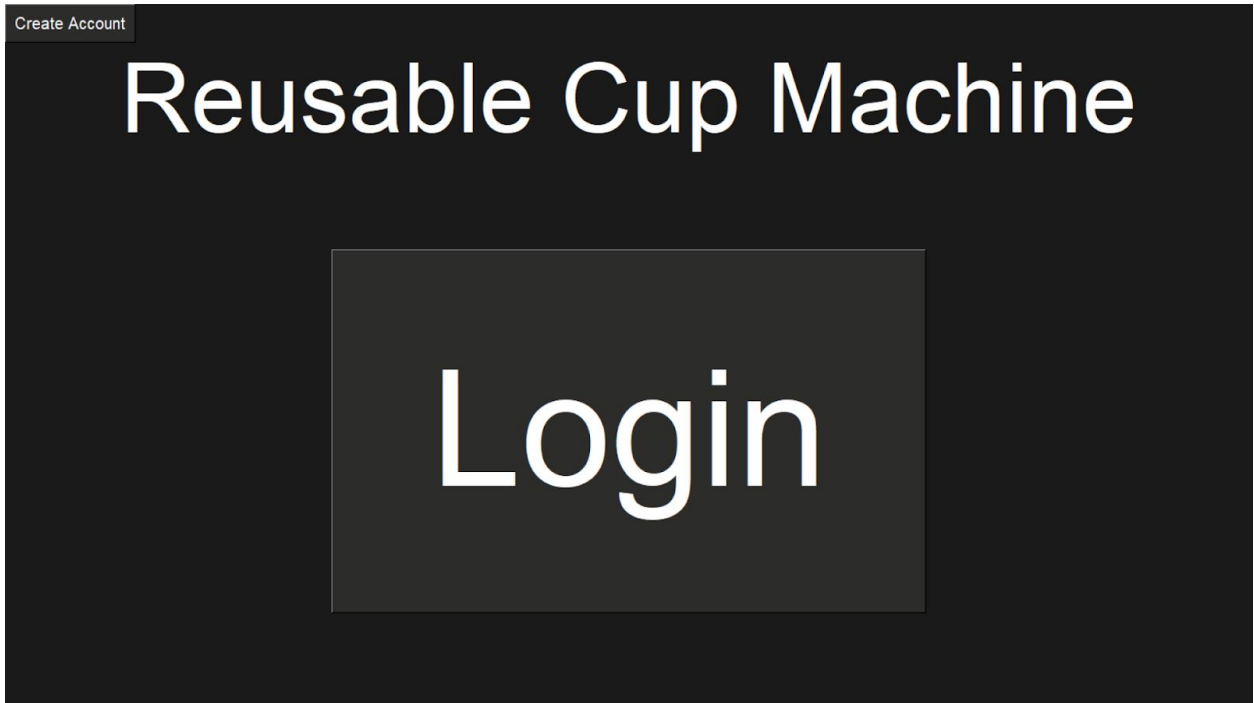

Create Account

## Login Screen

Username:

Password:

Next

Return Cup

Get Cup



Place Your Cup in the Ring

# Placed the Cup

Would You Like To  
Get a New Cup?

Yes No

Retrieve Your Cup  
From Below

Got My Cup

Thank  
You