

THE RESTORATION AND DESIGN OF PUERTO RICO'S SALINAS FORTUNA

Interactive Qualifying Project Report completed in partial fulfillment of
the Bachelor of Science degree at
Worcester Polytechnic Institute, Worcester, MA

Madalyn Moore

Katie Monighetti

Andrew Turgeon

Submitted to:

Professor Edward A. Clancy (Advisor)

Professor Fabienne Miller (Advisor)

In Cooperation With

Juan Rodriquez

Fideicomiso de Conservacion de Puerto Rico

May 2, 2013

Advisor Signature

Co-advisor Signature

Abstract

In preparation for the future development of Fideicomiso's Las Salinas Fortuna salt flats located on La Parguera nature reserve, our team conducted an analysis of the history and environment of the location and its infrastructures. The current facilities of Salinas Fortuna are dilapidated and without the supply of public utilities, for this reason the system is powered by a hand cranked diesel motor producing operational noise. Through interviews with employees and a study of a related location, our group developed a set of recommendations for potential construction, noise reduction, and educational opportunities. With the goal of environmental protection and historical preservation we tailored our ideas for the most beneficial long term outcome.

Acknowledgments

Thank you to Fideicomiso staff for the office accommodations and project assistance.

Special thank you to Juan Rodriguez, whose daily advice and support allowed us to achieve our project objectives.

Finally we'd like to thank the WPI community, Susan Vernon-Gerstenfeld, and our advisors, Ted Clancy and Fabienne Miller, for organizing and guiding us through this amazing opportunity.

Authorship

Abstract [Andrew](#)

Executive Summary [All](#)

Chapter 1: Introduction [All](#)

Chapter 2: Literature Review

2.1 Fideicomiso [Maddy](#)

2.2 History of the Salt Industry in Puerto Rico [Maddy](#)

2.3 Salt Flats Areas [Katie](#)

2.3.1 La Parguera Nature Reserve [Katie](#)

2.3.2 Cabo Rojo Salt Flats [Katie](#)

2.4 Motors [Andrew](#)

2.4.1 Current Salinas Fortuna Motor [Andrew](#)

2.4.2 Environmental Replacement Options [Andrew](#)

2.4.3 Mufflers [Andrew](#)

2.5 Noise Considerations [All](#)

2.6 Material Classifications and Considerations

2.6.1 Heat Island Impact [Katie](#)

2.6.2 Recycled [Katie](#)

2.6.3 Low Emitting [Katie](#)

2.6.4 Rapidly Renewable [Katie](#)

2.6.5 Pollution Protectant [Katie](#)

2.6.6 Biodegradability [Katie](#)

2.6.7 Water Resistant [Katie](#)

2.6.8 Recyclable [Katie](#)

2.7 Designing for Education [Katie](#)

Chapter 3: Project Considerations

3.1 Cabo Rojo Case Study [Maddy](#)

3.2 Interviews

3.2.1 Oscar Diaz (Cabo Rojo Salt Flats Manager and U.S. Fish and Wildlife Representative) [Maddy](#)

3.2.2 Cabo Rojo Employee (Tour Guide) [Maddy](#)

- 3.2.3 Cabo Rojo Refuge Employee (Salt Production) [Maddy](#)
- 3.2.4 John Murphy (Fideicomiso Construction Manager) [Maddy](#)
- 3.2.5 Jose Silva (Fideicomiso Southwest Management Coordinator) [Maddy](#)
- 3.2.6 Lister Petter Company [Maddy](#)

Chapter 4: Design of Future Visitor Attractions

- 4.1 Design of Visitor Infrastructure
 - 4.1.1 Methodology for Design of Visitor Infrastructure [All](#)
 - 4.1.2 Results and Discussion for Design of Visitor Infrastructure [All](#)
- 4.2 Design of Educational Visuals
 - 4.2.1 Methodology for Design of Educational Pieces [All](#)
 - 4.2.2 Results and Discussion for Design of Educational Pieces [All](#)

Chapter 5: Material Compilation

- 5.1 Methodology for Material Compilation
 - 5.1.1 Case Study of Cabo Rojo Salt Flats for Materials Compilation [Maddy and Katie](#)
 - 5.1.2 Materials Compilation [Maddy](#)
- 5.2 Results and Discussion for Materials Compilation
 - 5.2.1 Case Study of Cabo Rojo Salt Flats for Materials Compilation [Maddy and Katie](#)
 - 5.2.2 Material Compilation [Maddy](#)

Chapter 6: Restoring vs. Replacing the Salt Production System

- 6.1 Case Study of Cabo Rojo Salt Flats for Salt Production Analysis
 - 6.1.1 Methodology of the Case Study of Cabo Rojo Salt Flats for Salt Production Analysis [Katie](#)
 - 6.1.2 Results and Discussion of the Case Study of Cabo Rojo Salt Flats for Salt Production Analysis [Katie](#)
- 6.2 Gain Understanding of Water Moving Mechanism and Costs of Salinas Fortuna
 - 6.2.1 Methodology Used to Gain an Understanding of Water Moving Mechanism and Cost of Salinas Fortuna [Andrew](#)
 - 6.2.2 Results and Discussion of Gaining an Understanding of Water Moving Mechanism and Costs of Salinas Fortuna [Andrew](#)
- 6.3 Noise Analysis
 - 6.3.1 Methodology of Noise Analysis [Andrew](#)
 - 6.3.2 Results and Discussion of Noise Analysis [Andrew](#)

6.4 Full Motor Replacement

6.4.1 Methodology of Full Motor Replacement [Andrew](#)

6.4.2 Results and Discussion of Full Motor Replacement [Andrew](#)

6.5 Environmental Alternatives

6.5.1 Methodology of Environmental Alternatives [Andrew](#)

6.5.2 Results and Discussion of Environmental Alternatives [Andrew](#)

6.6 Motor Analysis

6.6.1 Methodology of Motor Analysis [Maddy](#)

6.6.2 Results and Discussion of Motor Analysis [Maddy](#)

Chapter 7: Recommendations Summary and Limitations [Katie](#)

Table of Contents

Abstract.....	2
Acknowledgments.....	3
Authorship.....	4
Table of Contents.....	7
Executive Summary.....	11
Chapter 1: Introduction.....	16
Chapter 2: Literature Review.....	19
2.1 Fideicomiso.....	19
2.2 History of the Salt Industry in Puerto Rico.....	21
2.3 Salt Flats Areas.....	23
2.3.1 La Parguera Nature Reserve.....	24
2.3.2 Cabo Rojo Salt Flats.....	29
2.4 Motors.....	32
2.4.1 Current Salinas Fortuna Motor.....	32
2.4.2 Environmental Replacement Options.....	32
2.4.3 Mufflers.....	34
2.5 Noise Considerations.....	35
2.6 Material Classifications and Considerations.....	38
2.6.1 Heat Island Impact.....	40
2.6.2 Recycled.....	40
2.6.3 Low Emitting.....	41
2.6.4 Rapidly Renewable.....	41
2.6.5 Pollution Protectant.....	42
2.6.6 Biodegradability.....	42
2.6.7 Water Resistant.....	43
2.6.8 Recyclable.....	43
2.7 Designing for Education.....	44
Chapter 3: Project Considerations.....	47
3.1 Cabo Rojo Case Study.....	47
3.2 Interviews.....	48
3.2.1 Oscar Diaz (Cabo Rojo Refuge Manager and U.S. Fish and Wildlife Representative).....	49
3.2.2 Cabo Rojo Employee (Tour Guide).....	49

3.2.3	Cabo Rojo Refuge Employee (Salt Production)	49
3.2.4	John Murphy (Fideicomiso Construction Manager).....	50
3.2.5	Jose Silva (Fideicomiso Southwest Management Coordinator)	50
3.2.6	Lister Petter Company	50
Chapter 4:	Design of Future Visitor Attractions	51
4.1	Design of Visitor Infrastructure	51
4.1.1	Methodology for Design of Visitor Infrastructure.....	51
4.1.2	Results and Discussion for Design of Visitor Infrastructure	54
4.2	Design of Educational Visuals	64
4.2.1	Methodology for Design of Educational Pieces	64
4.2.2	Results and Discussion for Design of Educational Pieces.....	66
Chapter 5:	Material Compilation	82
5.1	Methodology for Material Compilation	82
5.1.1	Case Study of Cabo Rojo Salt Flats for Materials Compilation	82
5.1.2	Materials Compilation	83
5.2	Results and Discussion for Materials Compilation	88
5.2.1	Case Study of Cabo Rojo Salt Flats for Materials Compilation	88
5.2.2	Material Compilation	89
Chapter 6:	Restoring vs. Replacing the Salt Production System	95
6.1	Case Study of Cabo Rojo Salt Flats for Salt Production Analysis.....	95
6.1.1	Methodology of the Case Study of Cabo Rojo Salt Flats for Salt Production Analysis.....	95
6.1.2	Results and Discussion of the Case Study of Cabo Rojo Salt Flats for Salt Production Analysis	96
6.2	Gain Understanding of Water Moving Mechanism and Costs of Salinas Fortuna	99
6.2.1	Methodology Used to Gain an Understanding of Water Moving Mechanism and Cost of Salinas Fortuna.....	99
6.2.2	Results and Discussion of Gaining an Understanding of Water Moving Mechanism and Costs of Salinas Fortuna.....	100
6.3	Noise Analysis.....	104
6.3.1	Methodology of Noise Analysis	104
6.3.2	Results and Discussion of Noise Analysis.....	107
6.4	Full Motor Replacement.....	110
6.4.1	Methodology of Full Motor Replacement	110
6.4.2	Results and Discussion of Full Motor Replacement.....	111

6.5	Environmental Alternatives.....	113
6.5.1	Methodology of Environmental Alternatives	113
6.5.2	Results and Discussion of Environmental Alternatives.....	113
6.6	Motor Analysis.....	116
6.6.1	Methodology of Motor Analysis.....	116
6.6.2	Results and Discussion of Motor Analysis	118
Chapter 7: Recommendations Summary and Limitations		125
References.....		128
Appendices.....		131
A.	List of Birds.....	131
B.	Motor.....	137
C.	Interview: U.S. Fish and Wildlife Contact and Cabo Rojo Refuge Manager, Oscar Diaz 138	
D.	Minutes from Interview with U.S. Fish and Wildlife Contact and Cabo Rojo Refuge Manager, Oscar Diaz	139
E.	Minutes from Interview with Cabo Rojo Refuge Employee (tour guide) 3/28/2013 ..	141
F.	Minutes from Interview with Cabo Rojo Refuge Employee (salt production) 4/19/13 ..	142
G.	Interview: Fideicomiso Engineer, John.....	143
H.	Minutes from Interview with Fideicomiso Engineer, John.....	144
I.	Interview: Jose (Area Coordinator)	146
J.	Minutes from Interview with Jose (Area Coordinator) 3/28	147
K.	Interview: Lister Petter (Company).....	148
L.	Minutes from Interview with Lister Petter and Realdiesel (Motor Company)	149
M.	Birds of La Parguera	151
N.	Materials Matrix.....	179
O.	LEED Certified Material Descriptions.....	183

Table of Figures

Figure 1: Fideicomiso Property Locations.....	11
Figure 2: Infrastructure Layout (Google, 2013)	12
Figure 3: Design Option 1.....	13
Figure 4: Design Option 2.....	13
Figure 5: Computer Aided Design of the Water Moving System	13
Figure 6: Map of Puerto Rico's regions and the Fideicomiso's properties ("Conservation Trust of Puerto Rico,").....	19
Figure 7: La Parguera Nature Reserve's Location and Boundaries ("La Parguera Nature Reserve (Eastern Segment),").....	24
Figure 8:Geographical Composition of Parguera Nature Reserve("La Parguera Nature Reserve (Eastern Segment),").....	25
Figure 9 Structure of Hypersaline Microbial Mats (DasSarma & DasSarma, 2012)	27
Figure 10: Map of Cabo Rojo (Peter Weaver & Schwagerl, 2008).....	31
Figure 11: Sound a Person Experiences in dB and Pa (Hansen)	36
Figure 12: Noise Level Limits in Puerto Rico (Tetreault et al., 2008)	37
Figure 13: Noise Log Components by Sound Source in El Yunque (El Yunque National Forest, 2009)	37
Figure 14: Sound Sources from El Yunque (El Yunque National Forest, 2009)	38
Figure 16: Site Identification (Google, 2013).....	56
Figure 17: Site Layout Measurements	57
Figure 18: Sketch of Motor House Dimensions	60
Figure 19: Design 1 of Motor House with Restored Operating System	61
Figure 20: Design two of Motor House with Non-Operational Old System as an Exhibit	63
Figure 21: La Parguera Nature Reserve (Fideicomiso)	69
Figure 22: Birds of Salinas Fortuna (Fideicomiso).....	71
Figure 23: Salt Production History (Lebrón Rivera, 2011)	73
Figure 24: Salt Production (Lebrón Rivera, 2011)	74
Figure 25: Salt Production Machinery in Salinas Fortuna.....	75
Figure 26: Diagram of Water Moving System Solidworks	77
Figure 27: Salinas Fortuna Salt Flats (Lebrón Rivera, 2011)	78
Figure 28: Ecosystem Diversity of Salinas Fortuna (DasSarma & DasSarma, 2012) (Kite Aerial Photography, 2010).....	80
Figure 29: Sound Test Distances	106
Figure 30: Exposed Exhaust Pipe of Current Motor System.....	109
Figure 31: Full Motor Replacement Sketches	112

Executive Summary

Fideicomiso de Conservacion de Puerto Rico strives to protect and preserve the natural ecosystems of Puerto Rico, whilst maintaining cultural integrity and educating people about the importance of saving their environment. Fideicomiso sponsored our group to assist them in developing a plan to preserve Las Salinas Fortuna Salt Flats, displayed in Figure 1, within La Parguera Nature Reserve.



Figure 1: Fideicomiso Property Locations

La Salinas Fortuna has historical significance to Puerto Rico's economy and environment. In the future, Fideicomiso intends to restore the Salinas Fortuna salt flats to imitate its past operation on a smaller scale for educational purposes. The current facilities of Salinas Fortuna are dilapidated and without the supply of public utilities. For this reason, the system is powered by a hand cranked diesel motor that produces loud operational noise. This restoration will retain the historical components of the salt production system while reducing its impacts on the surrounding environment.

In order to accomplish this restoration, we split our project up into three main objectives. The first objective was to develop a design of future visitor attractions. This included a site layout for the surrounding area consisting of visitor infrastructure: the motor house, a boardwalk system, bird watching stations, and a visitors' center. Incorporated into this layout was the design of educational pieces and where to place them. The second objective of the project was to compile a list a materials appropriate to build these infrastructures. The final objective of our project was to provide restoration and replacement options for the water wheel mechanics and drive motor used in historic salt production.

Project Considerations

After performing background research we developed two main methodologies, which captured the essence of our research. The development of these two main methodologies aided the completion of our objectives. The first methodology used was a case study of Cabo Rojo salt flats. The Cabo Rojo salt flats area is a government operated nature reserve and the only functioning salt production facility on the island. Our group used the Cabo Rojo salt flats as a model for our recommendations, while recognizing the possible imperfections that we could improve upon.

To gain primary source knowledge, our group conducted interviews as our second methodology. These interviews were conducted with Cabo Rojo refuge employees, Fideicomiso staff, and mechanical experts. From these interviews we were able to acquire information regarding salt production, nature reserves, least impact materials, and mechanical systems. Both of these methods will be used throughout the resolution of each objective.

Objective 1: Design of Future Visitor Attractions

One of the major methodologies used to accomplish this project was a case study of Cabo Rojo National Wildlife Refuge. We gathered information on how to reduce the impacts future tourism can have on the environment and the construction of the visitors' center and boardwalk.

Using the case study as a model, we met with Fideicomiso employees to develop a layout of the site and the location of each infrastructure component. The infrastructures include the boardwalk system, bird watching stations, visitors' center, parking lot, and the motor house. Figure 2 displays an aerial photograph of the project site and proposed surrounding infrastructure.



Figure 2: Infrastructure Layout (Google, 2013)

The main focus of the layout is the motor house. We developed two motor house designs; one incorporates building a sound proof enclosure around the current system, which will be restored to operating condition. This design in Figure 3 allows for the existing motor, located in the motor house, to be used “as is” or with a solar panel powered electric start. As determined by our research, the use of solar panels increases the environmental friendliness of remote locations. The other design, shown in Figure 4, incorporates transforming the current motor house into an exhibit. This design keeps the original machinery as a stationary historical display with hidden electric operation. In this design the electric motor draws electricity through installed solar panels.

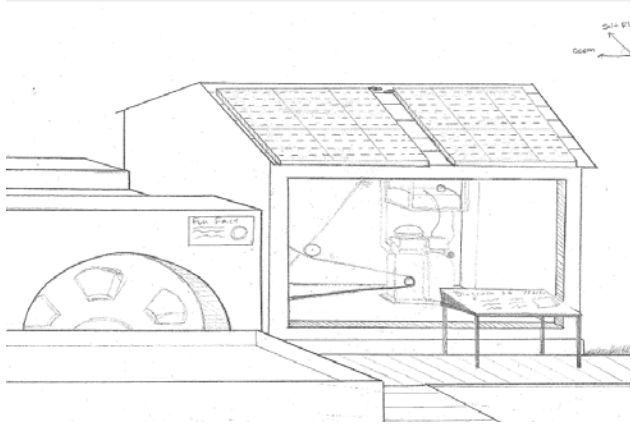

Figure 3: Design Option 1

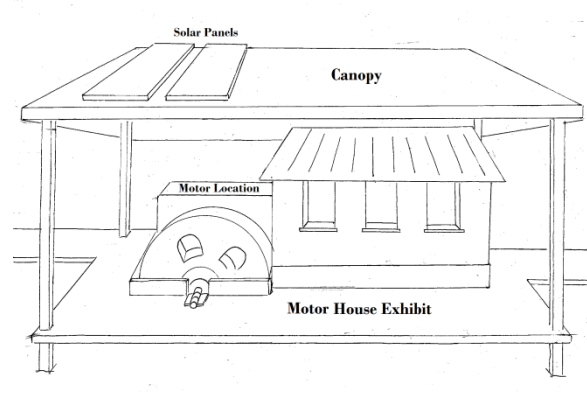

Figure 4: Design Option 2

Our design process also included drafts of educational material which will be displayed throughout the site. To elaborate on the water moving mechanism, a computer aided design of the system, shown in Figure 5, was created to educate visitors about the original operation used on site. Educational designs also included the history of salt production, the environment of Salinas Fortuna, birds of La Parguera, and the salt production process.

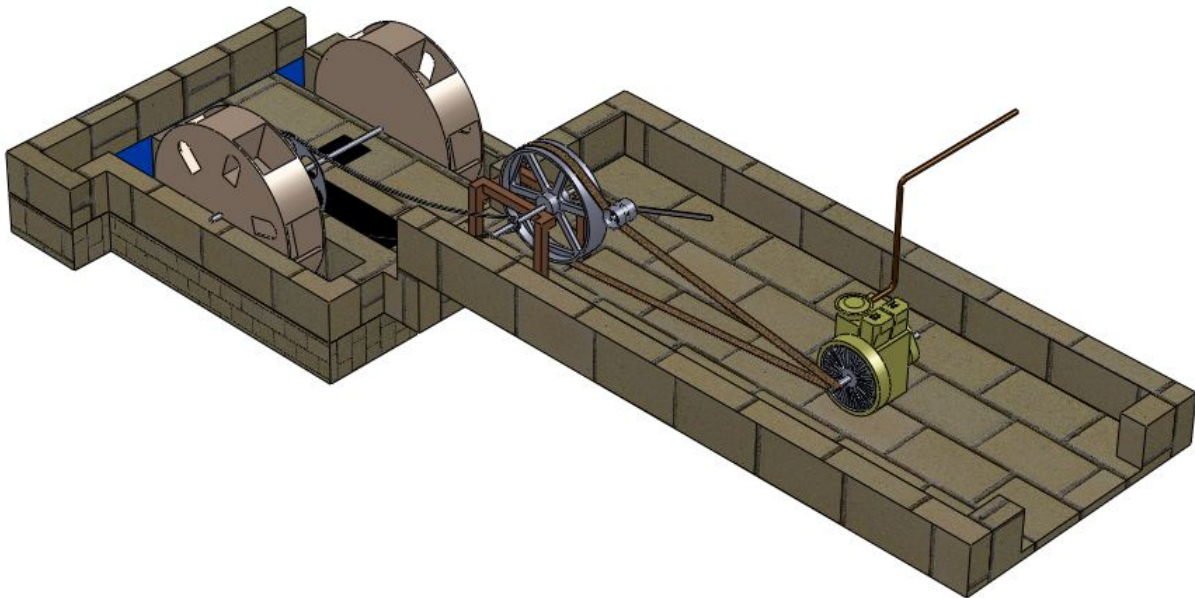

Figure 5: Computer Aided Design of the Water Moving System

Objective 2: Materials Compilation

After designing the site layout, our team focused on the materials appropriate for the construction of each infrastructure. Our group combined observations of materials incorporated throughout Cabo Rojo salt flat with the information gathered from an interview with Fideicomiso's construction manager, John. This provided our group with insight as to what

materials are currently used on the island and successful implementations of each material. Along with these observations, we researched and compiled a more in-depth list of material options. Fideicomiso employees then ranked the importance of the following material characteristics: type, the environmental friendliness, the cost, and the locality of the material. Using Fideicomiso’s ranking, along with LEED (Leadership in Energy and Environmental Design) standard rankings, we then created an all-encompassing materials matrix that identified the most appropriate materials for each future infrastructure. The final culmination of our materials research is produced in Table 1.

Name	Possible Use
PolyWhey Natural Wood Finish	Wood Sealants
SoyGrease EP Premium	Machine Parts
SoyGrease Semi Truck Fifth Wheel	Machine Parts
Gravel Pave	Parking Lot
Bioline	Inside the House
Pine	Infrastructures
Ausubo	Infrastructures
PVC Wood	Infrastructures
Sand	Foundations
Concrete	Foundations

Table 1: Materials Recommendations

Objective 3: Restoring vs. Replacing the Salt Production System

To make a recommendation on whether to restore or replace the motor of the salt production system at Salinas Fortuna, our team interviewed Jose, the southwest area coordinator. From this interview, we gained insight into the operating noise and maintenance costs associated with the current motor. Our group then conducted a noise impact analysis with a sound pressure level meter. We measured the ambient noise and compared it to operating motor noises, with the facility doors and windows both open and fully closed. The results of the study showed that enclosing the motor achieved a 30% noise reduction from 93 dBA, suggesting sound proofing is a viable option for reducing operating noise.

Our group contacted the manufacturer of the existing motor, Lister Petter, and researched equivalent replacements. With the original motor as a base line, we conducted an analysis to determine whether restoring the current motor or replacing it was the best option. Our analysis was based on a multi-attribute decision making process. The attributes taken into consideration were the cost, environmental friendliness, noise, sound proofing cost, and maintenance cost of the motor. Fideicomiso weighted the importance of each attribute, which were incorporated into the analysis. The results of the motor analysis indicated that replacing the current motor was the best option.

After determining that replacement was the best option, our group researched reducing the fossil fuel dependence of the system through incorporating environmental alternatives. Our research indicates that the implementation of photovoltaic solar arrays is the best option to provide electric power. The availability of electrical power makes possible the use of an electric motor to operate the existing machinery.

Conclusion

Our group provided Fideicomiso with restoration options for Salinas Fortuna salt flats, accounting for minimal negative impacts to the environment. We created educational material that highlights the historical and environmental significance of the area. To achieve this, our group completed our three main objectives: design of future visitor attractions, materials compilation, and restoring versus replacing the salt production system. Our design of future visitor attractions included a motor house, which employed the use of alternative energies and noise reducing options. To complement our design, we compiled a database of least impact materials to be used throughout future site construction at Salinas Fortuna. To ensure the future operation of production machinery, we provided Fideicomiso with alternatives to the current system, which will reduce fossil fuel dependence and preserve the sites historical individuality. With the consideration and implementation of our recommendations at the future site of Salinas Fortuna, we hope Fideicomiso will be able to allow for a positive interaction between visitors and the preserved environment.

Chapter 1: Introduction

Fideicomiso de Conservacion de Puerto Rico strives to protect and preserve the natural ecosystems of Puerto Rico, whilst maintaining cultural integrity and educating people about the importance of saving their environment. Fideicomiso is a non-profit organization that has dedicated knowledge, resources, and time to obtaining historical and at risk plots of land across Puerto Rico. In accordance with their mission, Fideicomiso is interested in developing a plan to preserve La Salinas Fortuna Salt Flats, within La Parguera Nature Reserve. The location is rich in wildlife, a haven for migratory and shore bird species, and contains an antiquated salt production site. La Salinas Fortuna maintains a historical significance to Puerto Rico's economy and environment.

In the future, Fideicomiso intends to restore the Salinas Fortuna salt flats to imitate its past operation on a smaller scale, for educational purposes. Our observations showed that the current facilities of Salinas Fortuna are dilapidated and without the supply of public utilities. For this reason, the system is powered by a hand cranked diesel motor that produces loud operational noise. This restoration will keep the historical components of the system and reduce the system's impacts on the surrounding environment.

Fideicomiso would like to draw visitors to the site as well as educate them on salt production, the local environment, and the interactions between them both. Fideicomiso has invited our team, from Worcester Polytechnic Institute (WPI), to travel to Puerto Rico and put together a development plan to assist them in starting the Salinas project.

The project was split into three main objectives. The first objective was to develop a design of future visitor attractions, which included the site layout of the motor house, boardwalk system, bird watching stations, and visitors' center, as well as motor house designs. Incorporated

into this layout will be the design of educational pieces and suggested placements. The second objective of the project is to compile a list of materials appropriate to build these infrastructures. The final objective of our project is to determine whether to restore or replace the current water wheel mechanics and drive motor.

The literature review of our report offers background information on Fideicomiso as well as the history of the salt industry in Puerto Rico. Our background research explains the process of salt production used at salt flats, such as the ones located in Las Salinas Fortuna and Cabo Rojo. A section is also included describing the types of motors used to drive water in salt production processes, specifically the type of motor used at Salinas Fortuna. To provide logical recommendations of least-impact materials for revisions to the motor house and for other tourism infrastructure, the report discusses the local materials available on the island as well as LEED (Leadership in Energy and Environmental Design) certified materials.

In addition to our background information, our methodology section details how we completed our and Fideicomiso's goals. In order to form recommendations to accommodate future visitors to the nature reserve, our group observed how other nature protected areas have utilized visitor centers and boardwalks. We specifically observed the only other salt flats located on the island at the Cabo Rojo National Wildlife Refuge. To do this, we conducted a case study of the refuge. We gathered information on the water moving system used, the salt flat system itself, and the materials and construction of the visitors' center and boardwalk. Along with observations of materials currently in use on the island, we researched and compiled other material options. We mainly focused on environmental friendly materials in order to comply with Fideicomiso's goals.

To make a recommendation of whether to restore or replace the motor at Salinas Fortuna, our team contacted the manufacturer of the existing motor, Lister Petter, and researched equivalent replacements to weigh the benefits and costs of various systems. We also conducted a noise impact analysis with sound measuring equipment. We measured the ambient and operating motor noises. We determined the sound pressure intensity created by the current water moving system and the controls that can be implemented. Finally, we created a cost and benefit analysis of repairing versus restoring the motor. With both our background research and methodology, we were able to analyze the issues surrounding salt flat restoration and development to provide Fideicomiso with realistic options for completing their goals. The following chapter provides background information on topics used throughout our project.

Chapter 2: Literature Review

2.1 Fideicomiso

Fideicomiso de Conservacion translates to “Conservation Trust.” Fideicomiso is a non-profit organization. Their all encompassing goal is to preserve Puerto Rico’s ecosystem, through education and protection. The organization has divided Puerto Rico into five regions based on main watersheds. These regions are Northern, San Juan Central, Southern, Eastern, and Western (Fideicomiso de Conservacion, 2013a). Fideicomiso owns a total of 32 natural areas. The map below, in Figure 6, displays these regions with the five different colors and indicates Fideicomiso’s properties with green dots.



Figure 6: Map of Puerto Rico’s regions and the Fideicomiso’s properties (“Conservation Trust of Puerto Rico,”)

In 1970, Puerto Rico underwent modernization and industrialization which took a toll on the island’s resources. As a result, the Conservation Trust of Puerto Rico was created through the Deed of Constitution of Charitable Trust. For the first ten years, Fideicomiso’s funding came from U.S. tariffs on petrochemical companies and from private payments of companies under the U.S. Internal Revenue Code. Soon thereafter, the federal government started providing Fideicomiso with rum tax returns as well. Today, Fideicomiso receives a majority of its income

through memberships in environmental programs, grants from the United States government, and land donation agreements (Fideicomiso, 2013b).

Fideicomiso strives to maintain a balance between what the island's ecosystem offers and what the people of the island use economically, socially, and culturally. In order to attain this balance, Fideicomiso strives to successfully achieve three goals (Fideicomiso de Conservacion, 2013a).

1. By 2033 to have 33% of the island's land protected, to maximize functionality and biodiversity.
2. Inspire visitors to connect with nature and rouse a sense of responsibility.
3. Promote a conservation culture.

Currently only 8% of the land in Puerto Rico is protected. Of this, 1% is protected by Fideicomiso while the other 7% is protected by non-governmental organizations and the Department of Natural and Environmental Resources. In order to reach their goal of 33% protected land, Fideicomiso promotes conservation easements. These easements assure protection of the land if landowners agree to certain legal restrictions. In exchange, a landowner is able to maintain the rights to their land and also receive governmental tax benefits due to the Conservation Easement Law (Fideicomiso, 2013a).

Fideicomiso has also already taken steps towards achieving their second and third goals, through educational and interactive programs that spread awareness. Participants in the programs build a relationship with nature and learn to respect it. One of their many programs is the Summer Immersion Camps, which are intended to educate participants about environmental responsibility at a young age. Young children and teens spend five days emerged in different natural areas of the conservation. In order to continue their education, Fideicomiso has reached

out to educators as well. They offer free educational materials to train teachers. Fideicomiso believes that if each person does their part to sustain the ecosystem, the organization can achieve their fundamental goals (Fideicomiso de Conservacion, 2013a).

To further protect Puerto Rico's history and environment, Fideicomiso purchased the Salinas Fortuna Salt Flats in the southwestern region of the island in 1996. Salinas Fortuna is considered a part of the Eastern Segment of La Parguera Nature Reserve (Fideicomiso, 2013a). The salt flats, though no longer functioning, serve as a historical landmark as well as a reserve rich in wildlife, particularly migratory birds. The Salinas Fortuna salt flats comprise of 1,616 acres, including bioluminescent bays, coastal mangroves, small lagoons, coral reefs, and sea grass beds. The reserve's vegetation also serves as home to an estimated 117 species of marine and terrestrial wildlife, including important migratory birds such as the snowy plover and least tern (Fideicomiso de Conservacion, 2013a). While the ecosystem of the area is important for preservation, the salt flats serve as an outlet for observing a production system for one of Puerto Rico's historical exports: salt.

2.2 History of the Salt Industry in Puerto Rico

Puerto Rico has had many uses for salt throughout its history: domestically, in hospitals, in bakeries, and for the military. The southern coast of the island was the best region to produce salt due to the dry, hot climate. At one point there were five different areas which produced salt on the southern coast; the two largest areas being Cabo Rojo and Lajas. The largest salt flat, Caborjenas Saltworks in Cabo Rojo, has been there since 700 A.D (Lebrón Rivera, 2011). Salt had been used as a commercial exchange for goods, on the island as well as with other islands, for many years before the Spaniards arrived and exploited this resource.

When Spaniard, Juan Ponce de Leon, became the governor of Puerto Rico in 1508, the Spaniards quickly took advantage of the salt flats and natural harbors on the island. Many salt flats were leased for 500 pesos per year. However, by 1578 salt production on the island had declined due to cost of production and transportation exceeding the revenue coming from salt sales (Lebrón Rivera, 2011).

The salt flats were forgotten until 1864 when the Island Government created a salt production industry, Salinas of the State. This resulted in a commercial movement on the southern coast of the island, where people began to migrate to and economically contribute to the area.

The Cabo Rojo salt flats were established across 939 acres, during this time. Workers would extract the salt with their hands and then carry it in a bucket to the shore, where salt merchants would pay about 25 cents per bushel in today's market. These salt flats produced thousands of bushels and established themselves as a major salt production facility within Puerto Rico (Lebrón Rivera, 2011).

In 1884 another salt flats area, Las Salinas de Lajas, was founded and consisted of 269 acres granted to Don Ulises Lopez. Workers in Lajas were paid three cents for each salt truck they filled. However, in 1890 Lopez leased the area to E. Cortada & Co. Throughout the years the land had various owners as Lopez began divide the property and sell individual parts. During this time the individual properties became known by the name Salinas Fortuna. It was not until 1996 that Fideicomiso acquired the land for the Natural Reserve of La Parguera in Lajas (Lebrón Rivera, 2011).

Salt production started to decline in 1898 when the new colonial metropolis, the United States, arrived to the island. The United States explored the agricultural, commercial, and

industrial possibilities of the island. There was an attempt to establish a franchise for the salt industry, however, it was not granted and the franchise focus switched to sugarcane. The use of the land on the south coast started to change and many salt mines were lost. By the 20th century, the salt industry had diminished to only a small portion of the 164 million dollar revenue of the mineral industry that now included higher profit minerals such as lime and concrete. The main source of salt that was still being manufactured was now coming from the Salt Company of Cabo Rojo (Lebrón Rivera, 2011).

Salt has been a constant component in the history of Puerto Rico. It is a natural resource as well as an economic and social resource. For this reason, Fideicomiso is striving to capture this historical significance through the preservation of the salt flats located in La Parguera Nature Reserve of Lajas.

2.3 Salt Flats Areas

Puerto Rican salt flats are located along the coastline, where the rise and flow of the ocean's tides can be utilized in the salt collection process. In order to collect the water, evaporation ponds are designed in a network structure, each incorporating a dam and sluice into their barriers to manage the flow of the incoming water. Water either flows naturally into the ponds, with the tides, or is drawn into the ponds through mechanical systems moving the water from one location to another. The ponds are flooded and the dams are closed, creating a system of standstill salt water ponds. The sun and wind evaporate the seawater, leaving behind thickly concentrated salt-water slurry: a process that can take several hours to several days depending on the depth of the water in the pond and the weather conditions outside. The salt crystals fall to the bottom of the pit where the salt begins to build up. Once a heavy layer of salt has settled, the remaining water is drained from the top of the ponds and the salt layer is scraped off the bottom

and then put into large piles to finish drying. Currently, the salt collected from these flats is typically not used for consumption purposes but for swimming pools and soil amendments. This process was used in the Salinas Fortuna salt flats during their years of operation and this process is still used in the operation of the Cabo Rojo facilities (Gwenn, 2011).

2.3.1 La Parguera Nature Reserve

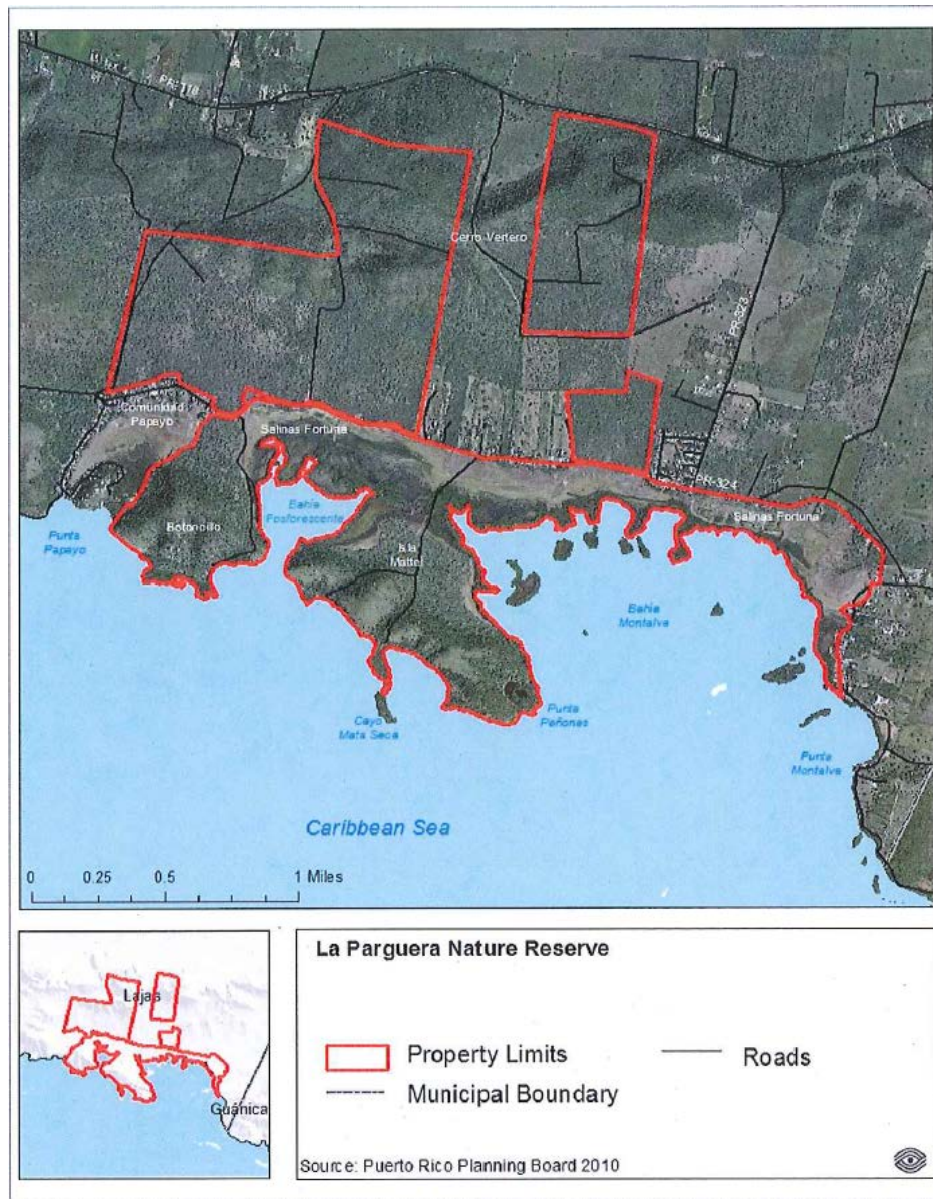

Figure 7: La Parguera Nature Reserve’s Location and Boundaries ("La Parguera Nature Reserve (Eastern Segment),")

Salinas Fortuna is located La Parguera Nature Reserve in Lajas, the driest of six life zones in Puerto Rico. In the 1940's, this area was a quiet fishing village. Since then it has developed into one of the most popular tourist destinations on the southwest coast of Puerto Rico. The reserve now protects 1,616 acres of land. The property limits are shown in Figure 7. The area is known for its marine resources, which include two bioluminescent bays, mangroves, sea grass beds, and a coral reef ecosystem. (Fideicomiso de Conservacion, 2013a)

LAND COVER AND ECOSYSTEMS	ACRES (approx.)	HECTARES (approx.)	% OF COVERAGE
Dry Forest	720.27	291.48	44.45
Dry Forest (Dense)	480.39	194.41	29.64
Salt Flat	214.12	86.65	13.21
Mangrove	148.80	60.22	9.18
Former Salt Production	39.41	15.95	2.43
Developed	12.30	4.98	0.76
Water	3.88	1.57	0.24
Beach	1.36	0.55	0.08

Figure 8: Geographical Composition of Parguera Nature Reserve ("La Parguera Nature Reserve (Eastern Segment),")

The majority of the land covered is dry forest which consists of 44.5% of the area. The distribution of land is displayed in Figure 8. However, former salt production mechanisms still remain a part of the reserve's composition. Within this area there are 291 species of plants, birds, mollusks, and other animal life ("La Parguera Nature Reserve (Eastern Segment),").

La Parguera was not established as a nature reserve until 1979. In 1978 the Puerto Rico Coastal Zone Management Program stated that the area had natural, scenic, cultural, and historical value. This program finally gave Puerto Rico Planning Board the motivation they needed to declare La Parguera a nature reserve. In 2005, the Department of Natural and

Environmental Resources classified La Parguera as a Critical Wildlife Area, which is when it became known as La Parguera Nature Reserve (Fideicomiso de Conservacion, 2013b).

2.3.1.1 Saline Environment

In saline environments, such as the one at Salinas Fortuna, are organisms called halophiles, which depend on sodium chloride. Halophiles are made of microorganisms such as halobacterium, cyanobacteria, and the green alga, *Dunaliella salina*. Halophoric organisms work to balance the osmotic stress of the environment. To improve their function in high salinity concentrations, they often produce acidic proteins to increase solvation (DasSarma & DasSarma, 2012).

As the level of salinity changes in this evaporation, so do the amounts of microbial species. From 1M NaCl to 3.5M, brine shrimp and larvae of brine flies feed on the dense algal which grows in this range of salinity (DasSarma & DasSarma, 2012). On the bottom of hypersaline ponds are microbial mats. These mats contain photosynthetic unicellular and filamentous cyanobacteria, purple and green sulfur, and nonsulfur bacteria. In the lower layer of the mat, as well as in the sediment below, there is homoacetogenic, methanogenic, and heterotrophic bacteria and archaea. These bacteria and archaea are sulfur oxidizing and sulfate reducing. Figure 9 displays the layers of the mat.

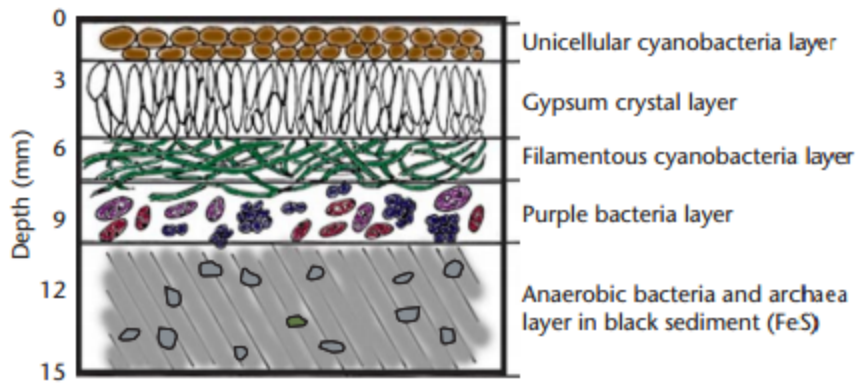

Figure 9 Structure of Hypersaline Microbial Mats (DasSarma & DasSarma, 2012)

The top brown layer of the mat is made of a cyanobacterial called *Aphanothece halophytica* which have a salt optimum of 3.5M. Other types of cyanobacteria such as *Oscillatoriales* and *Phormidium* create the green layer and grow at 1-2.5M NaCl. From 4M NaCl to saturation, halophilic archaea dominates the brine pools (DasSarma & DasSarma, 2012). Bacteria on the upper layers need more oxygen to survive than the bottom layers and therefore interact more with the process of absorbing the oxygen. The bacteria take in oxygen and carbon dioxide from the air and produce carbon sugars, oxygen, and water through chemical reactions. The carbon sugars, specifically, are important because it is these byproducts that react with the salt in the water to increase the salinity, thus fermenting the salt.

The fermentation process is directly related to the change in color of the evaporation ponds. When the salinity is lower the color is orange due to the brine shrimp, when levels are of medium salinity the color is green from the green algae, and finally, when the levels are high the color turns red from the halophilic archaea. Without these bacteria, the salt water would not ferment enough to evaporate out water and produce salt (DasSarma & DasSarma, 2012). The hypersaline environment also attracts many bird species to the organisms in the water.

2.3.1.2 Birds of La Parguera Nature Reserve

The endemic bird population of Puerto Rico is a very small majority of the islands total migratory avifauna population. Up to 212 species are recognized visitors of the island and of these only 12 are endemic to the island. Observations of migration patterns show the majority of birds appearing during three time periods as they migrate between North and South America. Over 25 species of shorebirds travel during the months of July to September, Warblers travel from September through October, and Waterfowl travel from October through November. The US Fish and Wildlife Service performed a 30 year record of these migratory species from 1972 until 2002. They found a range of 996-20475 individual birds and 65-112 individual species that travel to the island to nest and feed (Weaver & Schwagerl). Nature reserve staff in the area are constantly working to protect the natural environment the traveling, and local, bird needs.

Examples of specific bird species that are protected in La Parguera Nature Reserve are the Yellow-shouldered Blackbird, the Puerto Rican Nightjar, and the Brown Pelican (U.S. Fish and Wildlife Service, 2012). A more in depth list of the birds, which can be observed in the Parguera Nature Reserve, is located in Appendix A (Fideicomiso). The birds of La Parguera are located throughout the reserve, many of which can be observed directly at the salt marshes located at the Salinas Fortuna section of La Parguera.

2.3.1.3 Salinas Fortuna Salt Flats in La Parguera Nature Reserve

The recently purchased Salinas Fortuna salt flats, are approximately 214.12 acres in size with the past salt production section occupying 39.41 acres of the salt flat location. In the past, these salt flats utilized 20 crystallizing ponds that operated through the use of natural solar evaporation of water in these ponds. Now, there are only 7 evaporation ponds visible. The overall salt production system consists of watersheds, a water moving motor, and the

crystallizing ponds all of which are more than 100 years old. The general technique that the Salinas Fortuna salt flats used to use to create salt was to fill shallow crystallization ponds with salt water and then use the heat from the sun to evaporate the water out of the solution. Highly concentrated brine would be left behind and upon further drain out, large salt crystals would be collected (Fideicomiso de Conservacion, 2013b). While Salinas Fortuna may no longer be employing the use of their salt production process, Cabo Rojo facilities currently produce salt through a process similar to Salinas Fortuna.

2.3.2 Cabo Rojo Salt Flats

Cabo Rojo is located in Puerto Rico's most south western corner, 32 kilometers west of Salinas Fortuna. The subtropical dry forest climate of Cabo Rojo is identical to Salinas Fortuna due to the close proximity of the two salt flats locations. The refuge is covered approximately by 30% grassland, 5% shrub land, 20% shrub-woodland, 2% forest, 45% saline wetlands, and is 4% human developed. Trees taller than 30 feet grow in natural drainage depressions where water is most common. These depressions also make convenient natural homestead property lines and the trees provide excellent habitats for bats and birds (Weaver & Schwagerl, 2008). The areas positioning along the Atlantic Flyway make it a common resting, nesting and feeding place for migratory birds. The U.S. Fish and Wildlife Service has recorded well over 120 bird and 250 plant species. Regular recognizable bird species to the Cabo Rojo refuge are the Snowy Plover, the Least Tern, the Wilson's plover, the Peregrine Falcon, the Yellow Shouldered Blackbird, and the Brown Pelican (U.S. Fish and Wildlife Refuge, 2013). The Cabo Rojo refuge has gone to great lengths to protect these bird species. For example, in 2012, SOPI (Puerto Rican Ornithological Society Inc.) installed 25 signs around the Cabo Rojo national Wildlife Refuge

identifying specific locations as off limits critical nesting sites ("Nesting shorebirds protected at the Cabo Rojo Salt Flats, Puerto Rico,").

The Cabo Rojo National Wildlife Refuge was established in 1974 on land obtained from the US Central Intelligence Agency, for use as a prospective shorebird reserve. In 1999 the Cabo Rojo Salt Flats expanded the Wildlife Refuge, nearly tripling the reserve capacity from 590 to 1840 acres (U.S. Fish and Wildlife Refuge, 2013). Figure 10 displays a map of the boundaries of the reserve. The map shows the breakdown of the 1840 acre uses under the control of the United States Fish and Wildlife Service.

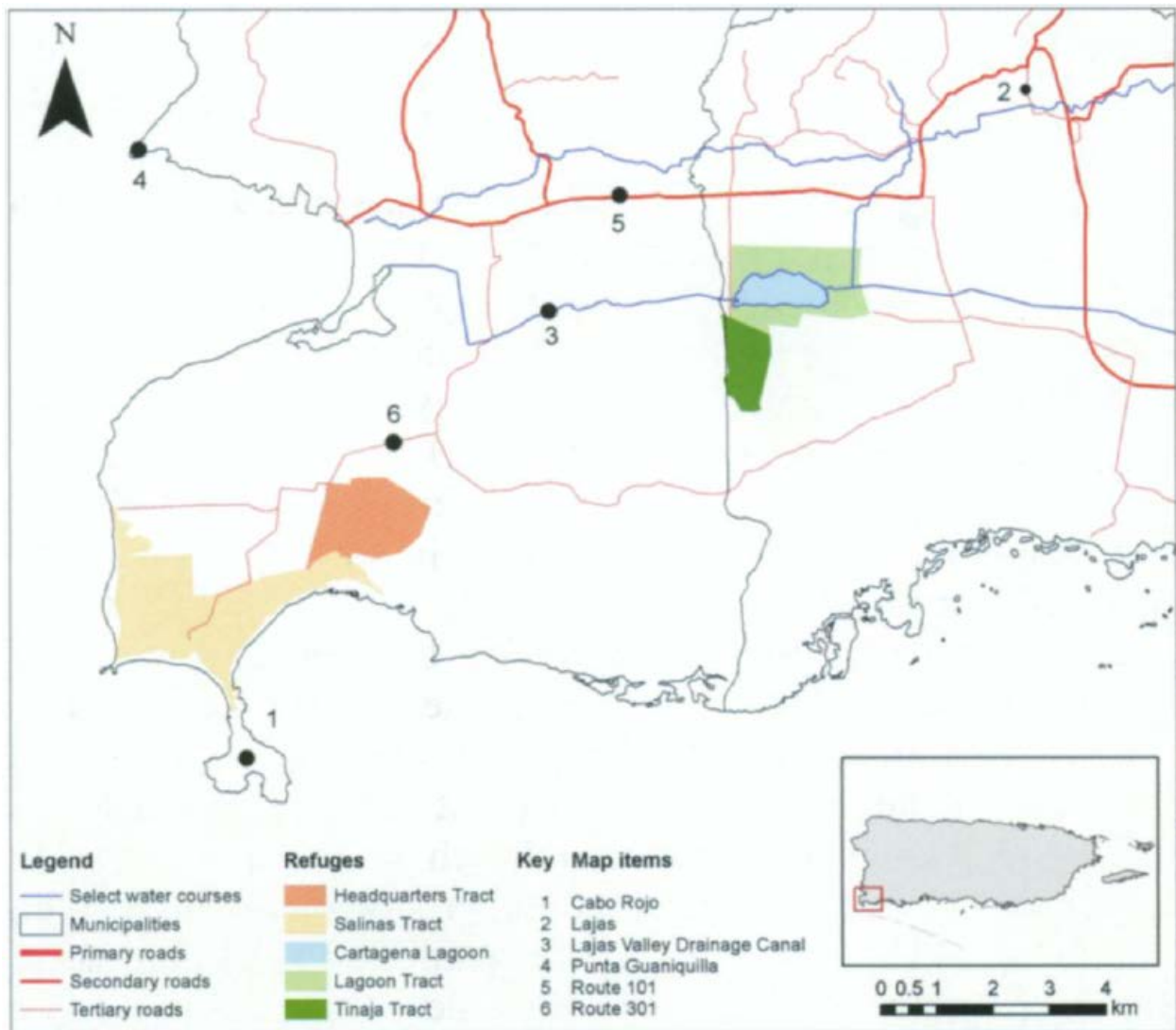

Figure 10: Map of Cabo Rojo Refuge (Peter Weaver & Schwagerl, 2008)

The U.S. Fish and Wildlife Service manages the Wildlife Refuge System and hosts its Caribbean Regional Office within the Cabo Rojo refuge. The initial intention of the refuge system was to protect wildlife and migratory waterfowl. Over time, with the increasing demand for public access and use of protected lands, the main uses have changed from solely protection to also include public outreach and environmental education. The Cabo Rojo refuge allows for observation, hiking, biking, and photography but prohibits hunting. In addition to protection, public outreach, and education, the Cabo Rojo refuge works to protect the

environment from the islands destructive ranching agricultural past (Weaver & Schwagerl, 2008).

2.4 Motors

Salt flats can transfer water to salt beds either through the use of a pump or motor system. Salinas Fortuna operated using a motor powered system.

2.4.1 Current Salinas Fortuna Motor

Salinas Fortuna uses a mechanical system to move the water from the canal to the salt flats region. The salt flats have no electricity to power the site and the machinery, therefore it was originally dependent on windmills which were replaced with fossil fuel machinery as the technology became available.

The current motor operating the power system for the salt flat water wheel was manufactured in 1964 and is the only piece of equipment to be fully functional at the site. The serial number of the motor is 2776HA214, breaking down into the production line number, 2776, the engine type is HA2, and the year code, 14. The HA series was produced between 1958 and 1969. It is a two cylinder, air cooled, 22 horse power engine at 1800 revolutions per minute that weighs 620lbs. The table in Appendix B displays the model information.

2.4.2 Environmental Replacement Options

In consideration of the antiquated systems potential detrimental impacts on the environment from its diesel dependence and age, alternative options to improve future site use may be beneficial. Fossil fuels, like diesel, emit harmful chemicals during use, like sulfur oxide or nitrogen oxide. These chemicals can react with both land and the air producing detrimental phenomena such as acid rain or ozone pollution. Fossil fuels are also non-renewable and

continuing their use will eventually lead to the resource running out permanently (Missouri Department of Natural Resources, 2001). Lister-Petter has been working with energy generation to create more environmentally friendly options, drawing customers away from exclusive fossil fuel dependence. Lister-Petter provides options when replacing a diesel motor with a hybrid or biodiesel systems. Hybrid systems combine multiple forms of electricity generation in order to provide a high level of energy security and independence. Although these systems are more expensive to install due to multiple technologies, they are designed by Lister-Petter for specific sites and resources to integrate Lister-Petter equipment. For customers interested in continuing their diesel use in a cleaner way, the Bio Rig 400 is an available biodiesel production unit alternative. Using a catalyst of caustic soda, it produces biodiesel in 5, 10, and 20% concentrations from vegetable oil and methanol. Beyond Lister-Petter's options, renewable energy sources are available as power supplies for the water system.

Electric drive integration is an alternative to the diesel motor that converts the diesel motor to an electric motor. Benefits of an electric power device are its freedom from fossil fuels, its negligible maintenance and upkeep, and its independence from a transmission or gear system to obtain a mechanical advantage. An electric motor operates through the manipulation of a magnetic and electric field (University of New South Wales, 2006). Opposite polarity force permanent magnets to rotate an electromagnet wire coil held between them called an armature. The electromagnet polarity changes during rotation to cause attraction to the permanent magnet it is approaching and then repulsion from it as it passes to continue the rotation cycle (University of New South Wales, 2006).

2.4.2.1 Solar Power Supply Integration

For future infrastructure at the site, an electrical supply is crucial. The most efficient and independent way to obtain power off the grid is with the use of a solar collector, a battery storage system and AC/DC inverter. Solar Photovoltaic technology converts solar radiation to electrical energy. Sunlight is absorbed by layers of semiconductors in arrangements of individual absorption cells. Cells are then combined into various size photovoltaic arrays based on the power requirements of the application. This process absorbs solar photon particles converting them into either immediate use power supply or stored energy in a battery capacitor bank. Power can be in one of two forms, alternating current (AC) or direct current (DC) or it may change from one to the other with an inverter. A wall outlet provides AC while a battery provides DC. An inverter is the box attached to the power cord between a battery operated device, a cell phone, and the wall outlet converting the provided AC into the DC power required. Solar Photovoltaic systems are becoming increasingly efficient, absorbing energy from more frequencies of the light spectrum, with nearly nonexistent maintenance costs (Solar Energy Development Programmatic EIS).

2.4.3 Mufflers

In addition to environmental considerations to reduce fossil fuel dependence, diesel motors typically produce loud noise during operation from the internal combustion of the system that should be reduced to limit the amount of sound emitted from the system. The vibrations created by the internal combustion of an engine perpetuate as exhaust gases are released. To counteract the noise created within the combustion chamber the exhaust outlet is typically fitted with a muffler built to fit the system by its manufacturer. A muffler is a sound diverter that breaks the consistent flow of sound waves coming from the engine. Various geometries of pipes

and baffles cause the sound waves to reverberate and interfere with each other reducing the amplitude of the sound wave. When a sound wave of a given frequency and amplitude is reflected back upon itself the waves can effectively cancel each other out. In cars this is an imperfect process as the sound wave frequency and amplitudes changes dramatically with engine speed while the reflection geometry stays constant. But in a stationary motor that maintains consistent revolutions per minute, mufflers can be ideally tuned for the maximum amount of destructive interference (Nice, 19 February 2001).

2.5 Noise Considerations

Reducing noise of machinery and humans alike is a typical focus of nature reserve areas due to noise potentially disturbing local wildlife through either interfering with communication calls or through scaring species away from nesting sites. In general, noise around 40 dB(A) is referenced to that of whispered speech, while noise around 90 dB(A) is referenced to that of sound from an operating newspaper press. Figure 11 below summarizes general references used for various sound pressure levels.

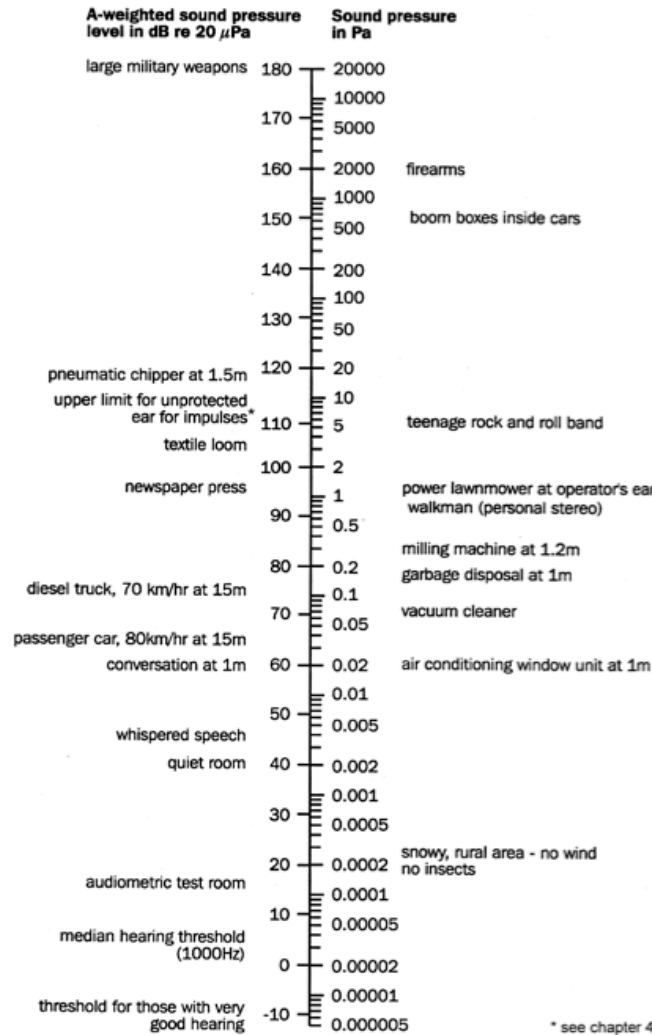

Figure 11: Sound a Person Experiences in dB and Pa (Hansen)

Federal and international organizations have been working to control noise issues related to working environments. The Noise Control Act was implemented in 1972 giving the Environmental Protection Agency (EPA) full responsibility of noise control. The Occupational Safety Health Administration (OSHA) also created noise pollution regulations. However, by 1982 this act was phased out and the responsibility was given to state and local governments (Tetreault et al., 2008).

State and local agencies have begun created new regulations to try to limit the noise pollution. One example is the noise level limits set in zones. The Environmental Quality Board in Puerto Rico has set the following noise levels for each zone shown in Figure 12.

EMITTING SOURCE	RECEIVING ZONES							
	ZONE 1 (Residential)		ZONE 2 (Commercial)		ZONE 3 (Industrial)		ZONE 4 (Quiet)	
	Daytime	Nighttime	Daytime	Nighttime	Daytime	Nighttime	Daytime	Nighttime
ZONE 1 (Residential)	60dB	50dB	65dB	55dB	70dB	60dB	50dB	45dB
ZONE 2 (Commercial)	65dB	50dB	70dB	60dB	75dB	65dB	50dB	45dB
ZONE 3 (Industrial)	65dB	50dB	70dB	65dB	75dB	75dB	50dB	45dB

Figure 12: Noise Level Limits in Puerto Rico (Tetreault et al., 2008)

Even with regulations, noise can still be an issue in protected areas. A noise study performed at El Yunque Nature Reserve of Puerto Rico revealed that noise was a common issue. A team set up four norsonic-121 monitors throughout El Yunque, one directly located in the bird sanctuary. The monitor recorded 48 hours of sound levels (Tetreault et al., 2008). Figure 13 shows the percentage of sounds recorded and Figure 14 shows the decibel range of each sound source.

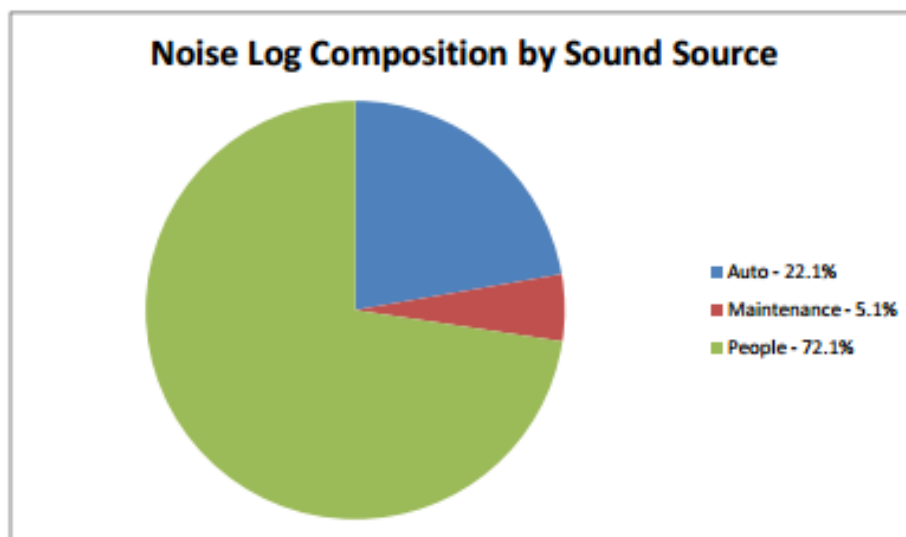

Figure 13: Noise Log Components by Sound Source in El Yunque (El Yunque National Forest, 2009)

Sound Source	Decibel Range [dB(A)]
Environmental Sound Level	41 - 51
Auto	54 - 72
Maintenance	73 - 78
People	48 - 70

Figure 14: Sound Sources from El Yunque (El Yunque National Forest, 2009)

The study revealed that much of the noise in a visited reserve is caused by the visitors themselves. The study found that the more the noise exceeded ambient sound, 50 dBA, the more the bird species were affected. Noise between 50 and 70 dBA interferes with birds communication, while noise above 70 dBA can scare birds away from nesting. The team recommends challenging the visitors to listen to nature and identify the environmental noises of the rain forest. This will reduce the amount of noise the visitors would normally create (Tetreault et al., 2008). If people visiting a site can create enough noise to negatively impact local species, louder noise from machinery, such as that located at Salinas Fortuna, can be inferred to have a negative impact as well.

2.6 Material Classifications and Considerations

In order to effectively recommend materials that have the least impact on the environment, an understanding of the properties that these materials should possess must first be obtained. The more environmentally friendly properties that a material has, the better that material is for the environment and the more likely that it should be implemented into building infrastructure. To ensure that the existing environment will still thrive in the future, humans must begin to limit the footprint that they leave on the environment and using environmentally friendly building materials is a beneficial place to start.

An acceptable way to accomplish least impact designs is through following the Leadership in Energy and Environmental Design (LEED) standards. LEED standards are a set of criteria

that score a building design based on how closely that building incorporated LEED criteria. Buildings designs are evaluated based on the reduction of carbon dioxide emissions, reduction of fresh water source uses, improvement of surrounding water quality, and reduction in the depletion of natural resources. Methods that buildings have used include reducing energy dependence through installing alternative energy systems that use solar or wind power instead of fossil fuels. This method reduces carbon dioxide emissions in addition to reducing the dependence on non-renewable fossil fuels. Other design criteria include, but are not limited to, reducing water dependence by 50% at an established site, a 10% decrease in energy consumption of an established site, and incorporating in 35% alternative energy dependence for electricity (United States Green Building Council, 2011).

Sites also consider the materials used in the design of their buildings. The most prominent consideration is the distance that material travels to the site of implementation. Transportation produces a great deal of pollution due to many modes of transportation being dependent on fossil fuels which release carbon dioxide and pollute the environment. Generally, all materials used should be manufactured, harvested, or extracted within an 800 kilometer radius from the project site. However, this can be difficult for some places based on location (United States Green Building Council, 2011).

In addition to distance, building materials must also show signs of reducing pollution through various material considerations such as heat island impact, recycled, low emitting, rapidly renewable, pollution protectant, biodegradable, water resistant, recyclable (United States Green Building Council, 2011). Through incorporating LEED practices into any project development, Fideicomiso can more easily achieve their goal of generating a least impact on the environment.

2.6.1 Heat Island Impact

One such LEED material certification property that should be considered is how effective that material is at reducing the heat island effect. Heat island impact is the property of a material to absorb the surrounding air temperature thus increasing its surface temperature. Depending on the materials absorption properties, the surface temperature of that material can be 27 to 50 degrees Celsius higher than the surrounding air temperature. This effect can cause problems in the environment and in communities alike. The increased use of energy also elevates the amount of air pollutants and greenhouse gases emitted into the atmosphere (Environmental Protection Agency, 2013).

A secondary impact to the increase in surface temperature of materials can be observed in water quality. When an area is subjected the rain, that water will run off the hotter surfaces of the materials and absorb some of the heat emitted from that material's surface. This runoff can flow into nearby streams, rivers, or lakes and begin to increase the temperature of that body of water as well. The increase in water temperature can become detrimental to wildlife dependent on that water, for instance too high of an increase can kill aquatic species or decrease production rates. The lack or decrease in aquatic life can negatively impact ground species that are dependent on the organisms in the water for nutrition. The cycle continues to domino until eventually the area can become uninhabited from the inability of that ecosystem to function (Environmental Protection Agency, 2013).

2.6.2 Recycled

A highly important material property, according to LEED, is whether or not the material has been recycled. Recycled materials are those that have been recovered or diverted from landfill or other solid waste deposit location. This diversion of materials can occur while the material is

being manufactured or after the product has been consumed. These products must come from rebuilt, reconditioned, or remanufactured parts in order for the product to be considered 100% recycled. Recycled products are beneficial to the environment because they reduce the amount of material in a landfill where it will continue to take up unnecessary space and potentially harm the environment through either not decomposing or from leaching out chemicals (Minns, 2008).

2.6.3 Low Emitting

Another desirable property in a low impact material is low emission. Materials when first installed will tend to emit chemicals that had been used during their processing. Typically these materials can be potent enough for the average person to be able to smell when walking into a new building for the first time. An example of such chemicals is a volatile organic compound like nitrogen oxide. Nitrogen oxide reacts to sunlight to produce ozone, a key contributor to smog air pollution. This emission of chemicals can cause dizziness, headaches, and irritation of the eyes nose and throat in humans and depending on the chemical, can negatively impact the environment as well. Low emitting materials contribute less to air pollution and are less of a health risk because they emit fewer chemicals into the environment after installation. This is an additional benefit in a tropical environment like Puerto Rico where high heat and sun exposure can cause chemicals to leech out faster. If harmful chemicals are not present in the material, no harmful chemicals can be released and therefore the material will leave less of an impact on the surrounding environment and people (Lent, 2007).

2.6.4 Rapidly Renewable

Another LEED certified material property is rapid renewability. Rapidly renewable resources are resources that can regenerate in 10 years or less. This is particularly important in

the environment because if a material is being harvested faster than it can grow, that material will slowly begin to disappear until it is no longer available for use or potentially extinct. Rapidly renewable materials are commonly fast growing woods, for example bamboo, that manufacturers have switched to using to diminish their impact on the environment (Maistry, 2007).

2.6.5 Pollution Protectant

Another LEED standard is the ability of a material to prevent pollution. These are materials that protect against air, land, and water pollution through limited negative interactions with the environment. Pollution protectant materials have few to no chemical alterations on their surface or within their structures. Any chemicals used in these materials are environmentally friendly and do not alter the surrounding acidity of the ecosystem. These materials can be porous, meaning that they allow for water to pass through them and filter, or allow water runoff to glide harmlessly over their surfaces without collecting any chemicals. Pollution protection attempts to prevent pollution at the source as well. This means that the material can be recycled in a safe manner or disposed of in such a way that does not leave a footprint on the environment (Environmental Protection Agency, 2002).

2.6.6 Biodegradability

A property that is newer in the material world is biodegradability. Biodegradability is the ability of a material to react biochemically with its surroundings to breakdown its compounds. This process is becoming an environmentally acceptable process because in order to provide a material with this property, companies are removing the harmful chemicals that can leech out during degradation. In doing this, the material breaks down with no negative impact to the environment. The degradation itself reacts with fungi or bacteria present in the surrounding

environment until all that remains are clean elements like carbon dioxide, water, or oxygen. The process is very similar to a leaf falling from a tree and landing on the earth below. Over time, natural bacteria from the earth will eat away at the leaf until the leaf is completely gone. The interaction between bacteria and biodegradable products is similar to the leaf and thus the materials themselves act almost as fertilizers to the earth they degrade in because of the beneficial chemicals they release during their decomposition (Hub, 2013).

2.6.7 Water Resistant

Another LEED consideration is water resistance in materials. Water resistance is the ability of a material to hinder the penetration of water. Often materials will have surface applied products that can waterproof the material to help prevent the interaction with water, while other materials have naturally water proofing properties that prevent interactions with water. With water resistant materials, water will make contact with the materials surface and instead of soaking into the material; it will run off the material. This is a beneficial property for a material to have, especially in foundation and pavement materials. For foundation and pavement materials, if the material is not effective with repelling water, the water can seep into the material and begin to push apart to internal connections between the aggregates. Eventually the aggregate will begin to loosen and break apart until the breaks propagate and the surface breaks. Interaction with water in this situation greatly reduces the structural integrity and calls for increased maintenance of the material to prevent the cracks from rendering the structure unusable (Mortar Net, 2009).

2.6.8 Recyclable

A property that is similar to recycled product is the ability of a product to be recyclable. The difference between recycled and recyclable is that a recycled material came from a reused

material. A recyclable material is a material that can be reused, rather than coming from a material that had been reused. A recyclable material benefits that environment because less energy and natural resources are needed to recycle a material. For instance, recycling material to make aluminum can s requires less energy than the energy needed to make that same aluminum can from scratch. This is largely due to the fact that when recycling a product, the material is already existent and is merely being reformed into its new form. When a product is being created from scratch, the material is not existent and must be formed form nothing which requires much more energy to form. Due to the fact that a recyclable material requires less energy to form, fewer greenhouse gases are emitted in the process and there is less of a contribution to the degeneration of the ozone layer. Ultimately, this helps to sustain the environment for future generations and ensures that the future will have natural resources available for these generations. This is particularly useful in building maintenance. Materials will degrade overtime, especially those exposed to the elements. A building that incorporates recyclable materials can reduce the solid waste pollution when maintenance occurs on that structure (Environmental Protection Agency, 2012). The culmination of these material properties will yield environmentally friendly options that can be used in future infrastructure designs.

2.7 Designing for Education

Fideicomiso properties incorporate education into infrastructures designs to communicate the individuality of the site. In order for visitors to retain information, educational material should evoke a mental or physical reaction through visual or hands on methods. Visuals should portray a large concept on a small scale that becomes embedded into the memory of the reader. This includes maintaining a strong connection between information and exhibit where the information provided uses simple and minimal wording to ensure that the purpose of that exhibit

is understood quickly and effectively. Employing the use of pictures, photographs, drawings, charts, and models are effective ways to convey purpose with little need for words (Singh, 2000). People who are able to visually observe exhibits are more likely to remember the purpose of that exhibit rather than if they were only presented with a paragraph of written work. Written work that is present should also be accurate. A way of achieving this is through the use of several different perspectives. Written work that comes from a variety of sources helps to eliminate bias and ensure that the information provided to the reader is precise, thus improving the information that visitors take-away with them (Bontempi, 2012).

Despite how accurate or succinct the display of information might be, if visitors are not provided with an opportunity to become involved with the material, they will lose interest and leave with less of a reaction to the site. A way of accomplishing increased interactions is through hands-on opportunities. Visitors often learn more from actions rather than passive observations. This could be as simple as providing visitors with the opportunity to touch a material used on site, or as complex as having visitors become involved with a process at the location. A more active learning environment can also be created through questions. Material that challenges the reader to ask questions and think about topics can help to stimulate that individual's interest and evoke that hands-on learning reaction. People more effectively learn when they are able to actively question information rather than blindly accepting the information they are provided with. The act of promoting questions is an effective way to help an individual actively learn the material (Bontempi, 2012).

In addition to asking questions, material provided at a location can evoke of sensorial responses. Techniques used to get students involved when visiting educational sites is through the use of written exercises. Students actively become involved in site exhibits when they are

searching for the answers to predetermined questions or when they have to document certain facts at locations. The act of writing down the material helps to reinforce desired purposes and further ensure that the person will remember the given material. Two such methods of performing this technique for active learning is through the use of a journal exercise where individuals are encouraged to write down their thoughts of certain exhibits or locations into a journal. This method also provides the individual with archived experiences that they will be able to refer back to and remember more readily than if they just relied solely on memory (Paulson, 1999).

The second method is through the use of quizzes. People provided with the incentive to answer questions correctly are more likely to search for those correct answers. Actively searching for answers also helps to absorb more information, or specific facts, and preserve these facts into an individual's memory. Museums or institutions can perform quizzes either through written material or through incorporating them into written material at sites where viewers must search the surrounding area for the correct answers (Halverson, 2007). The application of concise visuals, pictures, different perspectives, hands on activities, questions, journals, and quizzes are all methods that can be used to effectively educate visitors while on site.

Chapter 3: Project Considerations

Our three project objectives guided the completion of our project. Objective one was the design of future visitor attractions; this includes the design of visitor infrastructure as well as educational pieces. Objective two was the compilation of construction material options for use in future buildings and objective three was the development of recommendations for restoration versus replacement of the salt production system.

After performing background research, we developed two main methodologies that captured the essence of our project. These two methodologies included a case study of the Cabo Rojo salt flats and multiple interviews regarding related topics.

3.1 Cabo Rojo Salt Flats Case Study

The first method was a case study of the Cabo Rojo salt flats. The Cabo Rojo salt flats are a part of the Cabo Rojo National Wildlife Refuge and are the only currently functioning salt flats in Puerto Rico. The refuge is owned and operated by the U.S. Fish and Wildlife Service.

Our group worked under the assumption that the Cabo Rojo refuge is an established and reputable source to model after. This assumption was specifically important in the environmental design of the Cabo Rojo facilities. Although there was no visual authentication of the sites effective environmental design, an interview with a U.S. Fish and Wildlife contact revealed that environmental designs in nature protected areas are heavily regulated by the government. These regulations were enforced through the National Wildlife Refuge System Administration Act of 1966, which ensured the proper development of national wildlife refuges (United States Fish and Wildlife Service, 2013). We assume any information gathered from the case study was properly researched and developed due to the regulations of the United States government. Our group

used the Cabo Rojo salt flats as a model for our recommendations while recognizing the possible imperfections which we could improve for Salinas Fortuna.

Throughout our case study, one drawback to Cabo Rojo's design was the lack of citations on educational visuals. Due to this, our group did not use the material presented on the visuals. However, our group was interested in how established reserves present information to visitors. After performing background research on established methods used to educate visitors, our group found that the educational methods on the Cabo Rojo refuge were in accordance with our background research. This included methods such as displaying concise information complimented by many visuals, the use of questions to evoke a mental response from the reader, and interactive displays of the material.

3.2 Interviews

Our second method employed the use of interviews. Throughout the completion of our objectives, we conducted multiple interviews. The questions which we were unable to answer through our background research were incorporated into our interviews. The interviews followed a semi-standardized structure, using predetermined questions developed throughout our background research. Our final interview questions were reviewed by our project advisors. The interviews were administered verbally, with the assistance of our sponsor for occasional translation. To record these interviews, our group used field notes rather than electronically recording the conversation. Recording the conversation can often limit responses, an issue which we wanted to avoid (Berg & Lune, 2012).

3.2.1 Oscar Diaz (Cabo Rojo Refuge Manager and U.S. Fish and Wildlife Representative)

Our group interviewed Oscar Diaz, the manager of the Cabo Rojo refuge as well as a U.S. Fish and Wildlife representative. This interview was conducted over the phone due to Oscar's limited availability. We used this interview to aid the completion of all three of our objectives. The interview questions can be found in Appendix C (and the minutes from this interview are in Appendix D.)

3.2.2 Cabo Rojo Refuge Employee (Tour Guide)

While on site in Cabo Rojo, we interviewed two Cabo Rojo refuge employees. The first interview was informal and was conducted with our tour guide of the nature reserve facilities. This worker, who had a degree in marine biology, conducted tours through the area and provided groups with insight on the salt production system and the environmental dependence on this system. Aside from tours she mapped out the environment and monitored damages to the area caused from human interactions. This interview was used to obtain information for our first objective. Due to the unexpected nature of this interview we did not have questions prepared. (The minutes from this interview can be found in Appendix E.)

3.2.3 Cabo Rojo Refuge Employee (Salt Production)

While on site, we had the opportunity to speak with a Cabo Rojo refuge employee directly involved in the salt production process. Despite the fact that this employee was working, he took the time to meet with us. From this interview we were able to gather information on the salt production process. (The minutes from this interview can be found in Appendix F.)

3.2.4 John Murphy (Fideicomiso Construction Manager)

Fideicomiso employees were also interviewed in order to gain further information. John, a Fideicomiso construction manager, was interviewed in person to gather general information on methods used in design projects as well as his experiences in restoration projects he has performed in the past. John had completed several restoration projects for Fideicomiso; his most recent project is currently underway at La Hacienda Buena Vista in Ponce. These interview questions can be found in Appendix G (and minutes from the interview are located in Appendix H.)

3.2.5 Jose Silva (Fideicomiso Southwest Management Coordinator)

Another in person interview was conducted with Fideicomiso employee, Jose, the area coordinator of La Parguera Nature Reserve. Jose has been the area coordinator of the entire western part of the island for seven years, and has been maintaining the old water moving motor of Salinas Fortuna during that time. This interview was conducted to benefit our restoration vs. replacement analysis of the salt production system.. The interview can be found in Appendix I (and the minutes can be found in Appendix J.)

3.2.6 Lister Petter Company

To conclude our interviews, we spoke with employees from Lister Petter, the manufacturing company of the current motor used on Salinas Fortuna. A Lister Petter distribution center is located in Yauco, PR; however this interview was done over the phone as well as via email due to convenience. Information obtained from this interaction enhanced our development of restoration versus replacement recommendations. This interview is located in Appendix K (and the minutes are found in Appendix L.)

Chapter 4: Design of Future Visitor Attractions

Chapter four focuses on our group's first objective: to develop designs of future visitor attractions. This objective was split into two different sections; the first is the design of visitor infrastructure and the second is the design of educational pieces.

4.1 Design of Visitor Infrastructure

Designing visitor infrastructures comprised of the motor house design as well as site placement of the motor house, visitors' center, boardwalk system, and bird watching stations. The purpose of this section is to address the issues associated with design and restoration, and to provide the methods used to achieve the objective. This section presents results which include sketches, explanations on how lay out will incorporate visitors, and several alternatives for achieving this.

4.1.1 Methodology for Design of Visitor Infrastructure

4.1.1.1 Case Study of the Cabo Rojo Refuge for Design

The first portion of the Cabo Rojo salt flats case study focused on analyzing the design of visitor infrastructure, effective building designs, and the site layout. This design analysis of Cabo Rojo refuge focused on the layout of their visitor center, boardwalks, bird watching stations, and the incorporation of the environment into their design. Our group interviewed Oscar Diaz (Cabo Rojo refuge manager) on the limitations that government regulations can impose on the design layout of nature reserves as well as an explanation of how the Cabo Rojo refuge incorporated visitor infrastructure to highlight its diverse environment.

4.1.1.2 Researching Local and Migratory Species

We studied the environment to have an idea of the impacts of our work on the bird species located in the reserve. Our main focus was to determine how to provide positive human-nature interaction without affecting the local bird species. During our interview with Oscar Diaz (Cabo Rojo refuge manager) we discussed the methods used to protect the bird species located on the Cabo Rojo refuge. Fideicomiso also expressed interest in creating bird watching stations in order to draw attention to the birds located on the reserve. To avoid infringing on the birds' territory, we conducted research into the lifestyles and ecosystems of the various bird species surrounding the work area. To accomplish this, we visited the site and took field notes as well as pictures and sketches of areas that Fideicomiso indicated were bird territories. Fideicomiso was also able to provide us with a list of bird species located on Salinas Fortuna (Appendix B).

4.1.1.3 Site Mapping of Salinas Fortuna

Along with examining the territory of the bird species, our group determined the available space for infrastructure. Our goal was to provide Fideicomiso with a layout of how they will be able to utilize the land with multiple infrastructure options. Our group planned project limits by identifying the accessible area of Salinas Fortuna for infrastructure. To visually portray this, our team developed an overhead layout of the site with the assistance of Fideicomiso staff. The final site design was influenced by the infrastructure placement requirement provided by Fideicomiso. This site design was performed on an aerial photograph of the Salinas Fortuna area that included the shoreline, the salt flats area, and the dry forest adjacent to the Salinas Fortuna property. The site plan included plotting out locations for the visitor center and parking lot, two bird watching stations, a boardwalk system, the renovated salt flats, and the renovated motor house. The purpose of this site map was to understand where certain designs would be

implemented and to determine if that location had enough available land to manipulate without impinging on preserved mangroves or bird nesting areas. Fideicomiso was able to provide suggestions for appropriate locations for visitor infrastructure due to their experience with developing their other established reserve.

When our group was on site in Salinas Fortuna we performed a dimensional analysis of the specific areas; this included measuring the dimensions of the motor house, the water moving system, the sluice, the distance between the house and the road, the distance between the house and saltwater marsh, and the distance traveled down the road to the (proposed) future visitors center area. The restoration of the motor house will allow visitors to see the water moving system in operation. The boardwalk system will incorporate the entire site so that visitors can view the entirety of Salinas Fortuna. The bird watching stations on each side of the motor house will allow visitors to view wildlife without harming the surrounding environment. Finally, the visitors' center will display educational material.

4.1.1.4 Designing Visitor Infrastructure

The final stage of the development of our recommendations was how to use the land currently available at Salinas Fortuna in order to incorporate future visitor infrastructures without harming the surrounding environment. The design process was then broken down from the developed site map into the individual designs of each structure: the motor house, visitor center, bird watching stations, and boardwalk system.

From our interview with John Murphy (Fideicomiso construction manager) we gathered general information and recommendations on methods used to design visitor structures. We focused on techniques used when restoring versus replacing infrastructure, building design considerations, and methods used for limiting the environmental impact of these structures.

4.1.2 Results and Discussion for Design of Visitor Infrastructure

4.1.2.1 Case Study of Cabo Rojo Salt Flats for Design

A tour of the Cabo Rojo facility revealed the simplicity of their designs for visitor infrastructure. The visitor center had an open layout, and relied on natural lighting instead of electricity. Each wall had several informative posters describing the environment of the salt flats area, the types of animals that could be seen in that area, and information regarding seasonal changes to the area. There were also exhibits within the visitors' center that displayed replicas of types of birds of the area as well as types of nests that could be visible to visitors as they walked through the area. Behind the visitor center, a parking area had old fashion trucks used to transport salt from salt beds to where the salt is piled to dry. The boardwalk system then guided visitors around the salt flats and through specific locations that highlighted the vegetation of the area.

During our interview with John Murphy (Fideicomiso construction manager) he explained that the boardwalk system on the Cabo Rojo refuge was one meter wide, about 400 to 600 meters long, and the height from the ground ranged from .5 to .6 meters. The foundation for the boardwalk system was made of white pine, which was inserted into the ground. Where the ground was softer from interaction with the salt water, the wood reached 1.2 meters into the ground to ensure that the system remained stable. In areas where the ground was harder and more stable, the 4x4 posts only reached .5 meters into the ground. This interview had confirmed our observations of the system. The system as a whole was very simple. Performing this methodology provided our group with an understanding of how to incorporate infrastructure into the environment rather than onto the environment.

During our interview with Oscar Diaz (Cabo Rojo refuge manager) he explained some limitations with infrastructure designs on reserve sites, caused by governmental regulations. Nature reserves are required to approve their site designs under the National Wildlife Refuge System Administration Act of 1966.

Cabo Rojo refuge has also incorporated visitor regulations into the design of their visitor infrastructure. Trails were implemented through areas which would result in low impacts, specifically places that aren't highly populated with wildlife that might be disturbed by passing visitors. The design of this system helps to educate people on the importance of the surrounding ecosystem and the impacts that they can have on this ecosystem.

4.1.2.2 Salinas Fortuna Site Layout

In order to design for future infrastructure in Salinas Fortuna, an overall view of the area was obtained. Figure 16 below maps out the area that we incorporated into our design to ensure that our motor house area displays a view of both the ecosystem and the salt production system for demonstrational and educational purposes.



Figure 15: Site Identification (Google, 2013)

Figure 16 displays the Salinas Fortuna area, including the bioluminescent bay to the south that feeds water into the flood canal and to the motor house. The area to the right of the motor house is the marsh area where the migratory and local bird species establish their nests and feed. The salt beds are located to the left of the motor house which follows the mangrove forestry, home to different species of birds. Once an understanding of the size of the area was obtained, the suggestions for infrastructure placement could be made.



Figure 16: Site Layout Measurements

Our group created an overall site map, in Figure 17, which includes placement of the boardwalks, two bird watching stations, the general location for visitor parking and visitor center, and the motor house location. The design suggests how to employ the use of the land without negatively impacting the local environment. The Salinas Fortuna site currently has available area that can be used to create infrastructures without destroying natural vegetation.

A visitors' center, in green, and parking area, in purple, would be located across the road from the salt bed area. There is not a significant amount of land between the motor house, salt beds, and marsh area; the small distance that is available would not be enough to sustain a visitor center in addition to a parking lot. In order to create enough space for a visitors' center and parking lot, the surrounding environment would have to be destroyed or built over. This destruction does not comply with Fideicomiso's least impact goal. For this reason, the area surrounding the past salt storage facility, on the other side of the property, will be used for the future visitors' center. The area is spacious and would help to preserve the historical significance of the property due to its past involvement in the salt production process. The visitors' center can

be designed to resemble the old facility, therefore occupy the available space currently used by the run down storage unit. The land surrounding the old storage facility lacks vegetation and provides a large enough area which could be converted into a parking lot that would create access from the road to the visitors' center.

The boardwalk system, represented in blue, will be placed around the property to highlight both the historical salt production system and the diverse salt flat environment. As seen in Figure 17, the boardwalk system avoids the mangrove areas to prevent the destruction of natural habitats. The boardwalk system on the east side of the motor house begins and ends with a bird watching station. The north station allows for visitors to look over the entire marsh area and survey the types of birds that are common to the marsh area of a salt flat. The south station allows for visitors to survey the mangrove nesting areas. The boardwalk that extends from this north station then leads past the motor house where visitors would be able to stop and see the water moving mechanisms that help to move water from the canal system to the salt beds.

This boardwalk system design places the motor house as the central structure of the salt flats to help emphasize the importance of the water moving mechanism in the salt production process. In allowing visitors to walk around this motor house area, all phases of salt production can be observed without losing the significance of the surrounding environment. This boardwalk system would still maintain distance from sensitive bird nesting areas in order to minimize the impact of visitors on the ecosystem.

This boardwalk system continues to the west side of the property allowing visitors to walk along the salt beds that are vital to the salt production process. Here, visitors will be able to observe the beds used in the historical salt production process to their right, thus maintaining the historical significance of the area. Visitors will also be able to see the natural ecosystem of the

area to their left, thus maintaining the connection with nature that both Oscar (Cabo Rojo refuge manager) and the tour guide had stated were extremely important in a nature reserve.

4.1.2.3 Interview with Fideicomiso Engineer – Construction Manager John Murphy

John explained that each site has historical and environmental importance that needs to be maintained when restoring that site. John mentioned that he uses the original design and layout of the site. This means that the location of old machinery or walls of a building are rebuilt or refurbished such that they are in the same location as in the past. Many sites, however, require the structure to be reinforced in order to last longer. He explained a minimalistic approach that helps to keep the site simple while still maintaining its original importance.

John brought to our attention that many of the sites he has worked with are protected areas. When building in such environments, he and his workers are very careful not to leave behind any signs that they had been there. This prevents them from using any machinery and requires that construction or restoration be done by hand. They create established paths that go around protected areas and workers are required to use these paths in order to move around the site without harming the environment. John explained that projects take longer this way, but that it is necessary to ensure that the design leaves as small of an imprint on the environment as possible.

4.1.2.4 Initial Design – Sketches of the Motor House

To fully capture the historical significance of the salt production system on the Salinas Fortuna property, the motor house should be the central focus. Before creating designs of the motor house, we first developed a dimensional analysis of the current motor house. This analysis determine the general layout of the motor house as well as the space necessary to design for. Displayed below, in Figure 18, is a sketch of the motor house and its dimensions. Once we completed our dimensional analysis we were able to develop our future motor house designs.

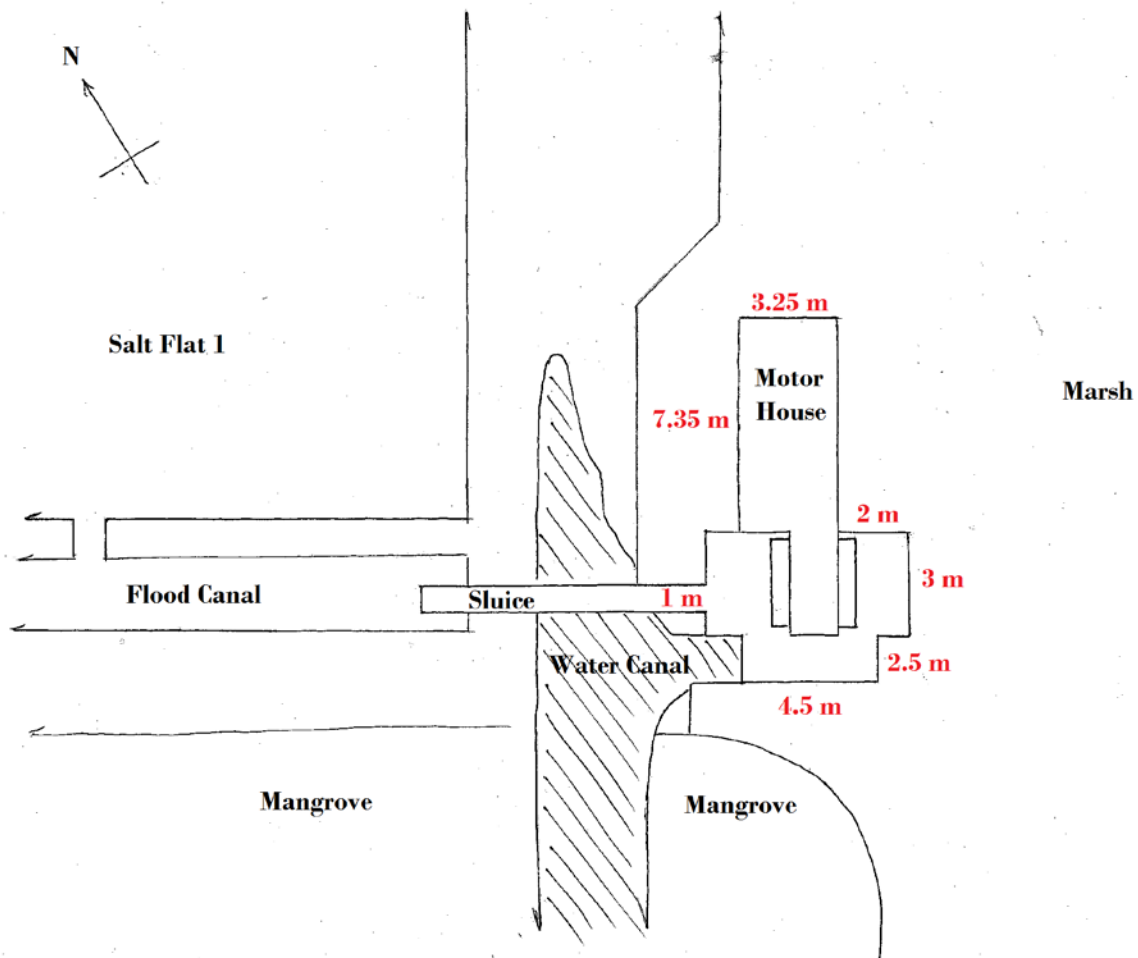

Figure 17: Sketch of Motor House Dimensions

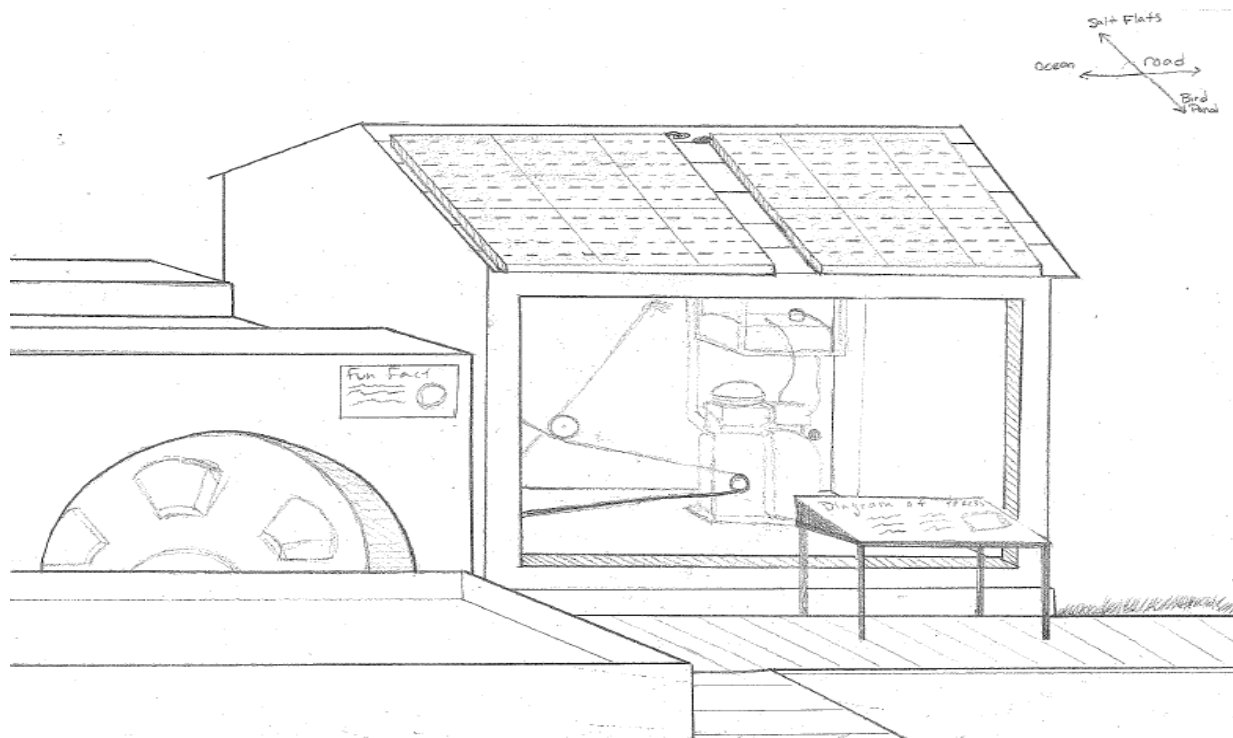

Figure 18: Design 1 of Motor House with Restored Operating System

The first design option of the motor house, shown in Figure 19, incorporates a restored operating system. The design includes enclosing the motor inside the motor house and installing a large window on one side such that visitors can see the system operating without disruption from the motor's noise. To prevent any noise pollution caused by the mechanical operation of the water moving system, which could negatively impact the birds, it would be necessary to enclose the operating motor in a sound proof shack. A study in El Yunque rain forest in Puerto Rico, as described in our background (United States Department of Agriculture, 2006), portrayed the impact that human speech, which rarely exceeds 70 dB(A), can have on bird species. The operation of the motor well exceeds 70 dB(A), as observed in Chapter 5, therefore the motor's operation could potentially disturb the nesting habits of the birds.

This motor house design option also incorporates environmental alternatives. Fideicomiso strongly supports minimally impacting the environment. One way to reduce

environmental impacts is through developing options, which will decrease fossil fuel dependence of the current diesel motor. Due to the climate of southern Puerto Rico, there is year round opportunity to harvest solar energy. Solar panels, an environmental friendly option, can be incorporated into the system to take advantage of the solar energy availability, as suggested from our background research. Design 1 shows the use of solar panels which would be incorporated into an electric start of the motor system. The solar panel attachments would reduce some of the diesel dependence of the system and eliminate any dependence on grid electricity. However, John mentioned that restoration projects are often performed with a simplistic approach that integrates the complete historical design without alterations. Our design can also exclude the solar panels, if Fideicomiso does not wish to alter the water moving system in any way. In this instance, the system would be restored but operated the same way that it had been when Salinas Fortuna was an established salt production site. The building would look the same so as to highlight the various components of the salt production system and allow visitors to see its operation.

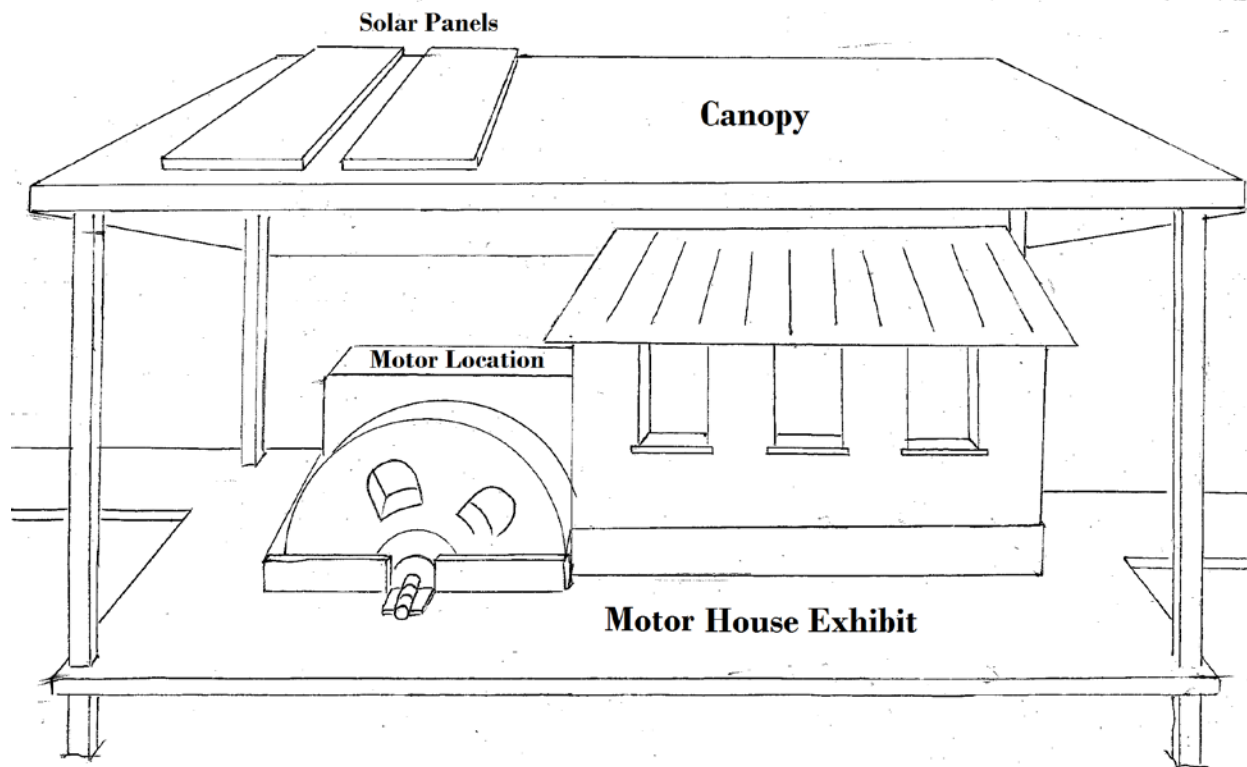

Figure 19: Design two of Motor House with Non-Operational Old System as an Exhibit

The second design, Figure 20, for the future motor house incorporates a new motor into the system. This design would maintain the existing motor house structure and would restore the materials so that the house was able to support visitors. In this situation, the entirety of the old motor house would become the exhibit, showcased inside of a canopy-type structure. This canopy structure would highlight the motor house as the central exhibit of the property and completely display the system that was originally used. An electric motor would be incorporated to have a direct connection to one of the water wheels, which would be restored to be fully operational. This motor would be hidden from view so as to not alter the historical significance that is maintained in this design. The rest of the system, including the other water wheel and the gear/belt/motor system, would be cleaned and put on display as if it could run the system, but without being operable.

In this design, visitors would be allowed to walk around the whole system and see the layout of how the salt flats used to operate, while still being able to observe the actual production of salt through the new electric motor system. The electricity to the motor would be provided through a solar panel array located on the canopy over the system, thereby reducing the alterations to the original mechanical system. This addition would require slight alternations to the original building structure; however, through incorporating solar panels into the design, Fideicomiso would show visitors that they are working to help improve the environment through decreasing dependence on fossil fuels, thus leading by example.

4.2 Design of Educational Visuals

Designing educational materials involved researching effective methods for teaching as well as observing other sites' methods for educating, specifically Cabo Rojo. This section includes designs of the educational pieces as well as options to effectively educate visitors.

4.2.1 Methodology for Design of Educational Pieces

In order to have completed our future design, our team developed educational material into infrastructure design. Our team researched effective methods established museums have used to educate their visitors, employed the use of the Cabo Rojo salt flats case study, and developed educational visuals that highlight characteristics of the Salinas Fortuna area.

4.2.1.1 Case Study of Cabo Rojo Salt Flats for Education

In our visit to the Cabo Rojo salt flats, our group paid particular attention to the design of the educational material that the Cabo Rojo refuge used throughout their facility. In order to document this, our group took pictures of the material that the refuge used. Our team also documented our observations of educational material placement while we were brought on a tour

of the salt flat and nature reserve area. Educational material at the Cabo Rojo refuge was analyzed based on picture placement, language, and the relevance of the information. Our interview with the tour guide further expanded on the information presented on the educational visuals. These observations provided our team with suggestions on how to present educational material at Salinas Fortuna.

4.2.1.2 Development of Educational Visuals

To complement our Cabo Rojo salt flats case study, our team also conducted background research into methods that other museums and persons have used in educating visitors. This research was conducted primarily using online resources of archival sources and can be referenced in Chapter 2: Literature Review. The focus of this research was to further determine effective techniques for educating adults and children alike, such that any material we developed had a clear purpose that future visitors could clearly understand and learn from.

Through the case study and online research, our team designed educational visuals that highlighted the history of salt production, the process of salt production, the salt production specific to Salinas Fortuna, the historical landmarks of Salinas Fortuna, the composition of La Parguera nature reserve, the specific bird species of La Parguera, and the diverse ecosystem of Salinas Fortuna. This material was developed using Microsoft PowerPoint and incorporated images from online resources, historical documents provided by Fideicomiso, and from photos taken while onsite.

Our team also developed an educational diagram of the water moving system both in sketch form and in the computer-aided design program, SolidWorks. The purpose of this material was to provide visual aids that could more clearly portray, to the visitors, how the mechanical system for moving the water from canal to salt bed functioned. The SolidWorks

design provided the viewer with a three-dimensional layout of the system to develop a realistic representation of the system.

4.2.2 Results and Discussion for Design of Educational Pieces

4.2.2.1 Case Study of Cabo Rojo Salt Flats for Education

To complement our understanding of the Cabo Rojo system, our interview with the Cabo Rojo refuge tour guide provided insight into the ecosystem surrounding a salt flat location. On our tour, she described that many birds migrate to the salt flats to nest around the salt beds during different seasons. At this time of year, the workers stop using these salt beds for three to five months to provide the birds with enough distance to not disturb their nesting patterns. The actual salt production is then performed in another location so that the machinery needed to produce salt is not on sight operating and negatively impacting the birds and environment.

During our tour, she also described how the environmental considerations of the Cabo Rojo refuge go much deeper than the visible ecosystem. The soil deposits in and around the salt flats were filled with bacteria that is necessary to properly produce and grow salt. When harvesting, Cabo Rojo refuge employees know to move the salt water along based on the pink coloration of bacteria fermenting the salt water. At this point the salt water has increased in salinity to a level that is appropriate for salt extraction. Workers will also leave the bottom layer of salt in the salt beds during harvesting in order to provide the bacteria with enough salt to continue to thrive and ferment.

The Cabo Rojo refuge employee peeled apart a piece of the soil near the salt flat and showed how there were different layers in the soil, each with its own type of bacteria. These layers, she explained, were comprised of specific cyanobacteria that are photosynthesizing

bacteria. The layers of these bacteria formed based on the level of oxygen each needed to survive, cyanobacteria that needed oxygen to live were towards the surface while the bacteria that lived without oxygen were towards the bottom layers.

She explained that in order to fully understand how salt is formed and harvested, workers and visitors must also understand the bacteria that work at helping the salt production along. Without properly interpreting the bacteria and other wildlife of the area, the salt production system would do harm to the surrounding ecosystem and eventually become unsustainable in that location.

While at the Cabo Rojo salt flats, our group observed the educational material displayed on site. We recognized that each sign was written in both Spanish and English. Due to this we proposed that both languages be present in developed educational pieces. We also observed the use of imagery on display. Specifically when looking at their signs about bird species located on the reserve, there were many pictures of the different types of birds.

We also incorporated ideas from a prior noise study done in El Yunque Natural Forest (United States Department of Agriculture, 2006). The authors of this study recommended challenging the visitors to listen to nature and identify the environmental noises of the rain forest. We created pages of a book which included the family of each bird, the scientific name, the Spanish name, English name, call of the birds, as well as usual habitat of each. We also recommend that the Fideicomiso offer binoculars. By encouraging visitors to listen to the call of the bird and to use the binoculars to view the different types of birds, not only will this decrease the noise visitors make but it will also increase the visitors' motivation to learn about the bird species (United States Department of Agriculture, 2006).

4.2.2.2 *Educational Visuals*

The culmination of our research and interviews aided the development of educational visual designs for potential educational material that could be present at the future Salinas Fortuna site. Our group designed material to focus on the specific salt flats production process as well as highlight the composition of the ecosystem in the salt flat area. The educational visuals below are the final results of the educational design and were designed in such a way as to ensure that the material is both relevant and memorable, as developed from our Cabo Rojo salt flats case study and background research.

The information is limited to the important facts and bulleted to help break up the information and make the material less intimidating to the reader. When the reader has finished reading the information on the educational visual, they are provided with a picture to complement the thoughts presented on the board. The picture ties together all the presented information and increases understanding in the reader as well as helps them to remember the process through relating it to an actual picture of the process.

Due to the limitation of a language barrier, our educational examples will only be developed in English. However, it is our intention that the final educational visual designs be displayed in both Spanish and English. Having the dual language ensures that the material would be available to the widest range of visitors because the two most common languages in Puerto Rico are Spanish and English. The educational visuals would be on a 0.66 meter by one meter board, as dictated by current Fideicomiso educational display criteria. The size of the poster board would ensure that both translations would be readable and that several people would be able to stand around the board simultaneously and easily read the information.

A flow will be created that begins with generalized information and eventually becomes more and more specific to Salinas Fortuna. Information presented in this style is able to build off the information prior to help ensure that the final presented information has a strong foundation and can be remembered.

4.2.2.2.1 La Parguera Nature Reserve

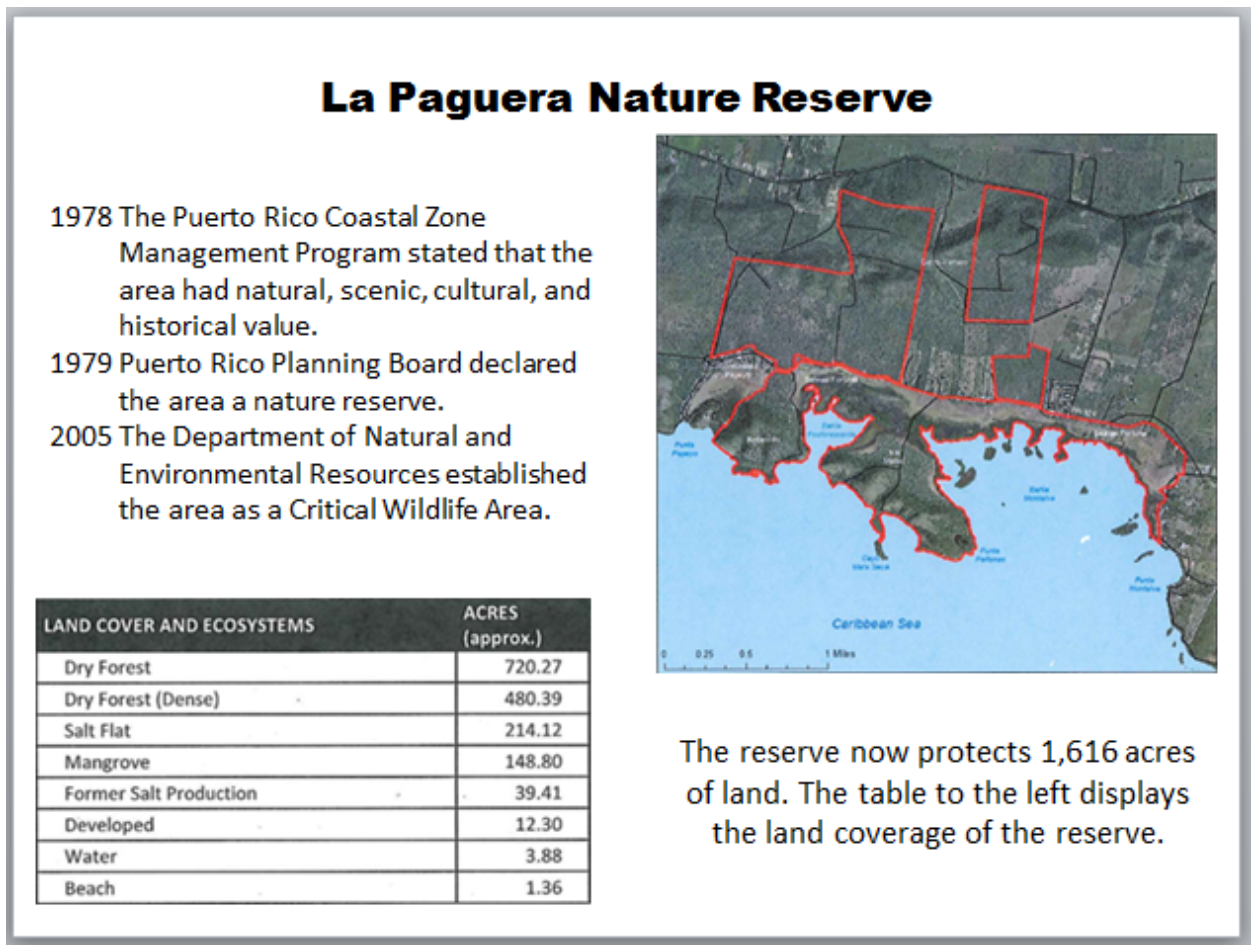

Figure 20: La Parguera Nature Reserve (Fideicomiso)

This educational visual creates the mindset necessary for the complete understanding of Salinas Fortuna operations. Salinas Fortuna is but a small part of the entire Parguera Reserve. This educational visual balances pictures with written information and the text provided is succinct and bulleted to minimize potential confusion and increase the opportunity to maintain the reader's attention.

This educational visual would likely be located near or in the visitor center because the information is an overview of the entire La Parguera Reserve. Visitors would be expected to be able to obtain a general understanding of the reserve as a whole before walking to the actual salt flats site. Displaying information early in the site layout will help to create perspective for the salt flats area and provide the reader with background knowledge before they proceed further into the historical area.

4.2.2.2.2 Birds of Salinas Fortuna

Note: For the rest of the Birds of Salinas Fortuna educational visual, refer to Appendix M.

FAMILY	SCIENTIFIC NAME	COMMON SPANISH NAME	COMMON ENGLISH NAME	ORIGIN	VOICE	HABITAT
Accipitridae	<i>Buteo jamaicensis</i>	Guaragao Colirrojo	Red-tailed Hawk	Resident	“Keer”	Forested Areas



Figure 21: Birds of Salinas Fortuna (Fideicomiso)

In the literature review, Section 2.3.1.2 “Birds of La Parguera Nature Reserve”, is where the information used to create this educational visual can be located. Once the visitors leave the parking area, they would be guided to the beginning of the boardwalk system located on the other side of the road. This system begins with the north side bird watching station where visitors will be allowed to ascend a stair system up into the bird watching tower. At the top of the tower would be a platform where information would be catered towards the wildlife that that person would be expected to see. The educational visual “Birds of Salinas Fortuna” would be presented as a booklet containing the 28 birds specific to the salt flats location. This booklet can be presented in at least two ways: as a booklet handed out to visitors upon reaching the site to carry with them through the entire site or as a large book printed on plastic pages and stationed at the top of each bird watching station for visitors to be able to flip through and look at each tower station. The information on each page would contain a picture of the bird, its name in English and Spanish, its origin, its type of call, and where the viewer would expect to see the bird. The information is concise and created to focus on the picture of the bird to help the viewer in potentially identifying that bird at Salinas Fortuna.

To further captivate the attention of the visitor, headphones could be made available at the top of the bird watching stations that play the different bird calls for the visitor. The headphones could be attached to a hidden re-chargeable battery powered recorder located either behind the bird watching information or below the floor of the bird watching platform.

Visitors could also be provided with a type of binocular system to aid them in bird watching. Binoculars could either be available to rent at the visitor center or coin operated telescopes could be stationary mounted on the bird watching platform. This addition would allow visitors to enhance the view and increase their chances of seeing a bird in its natural habitat.

Through creating a more interactive system of bird watching, visitors would have an increased chance of remembering the experience and absorbing the material presented (Bontempi, 2012).

4.2.2.2.3 Salt Production History

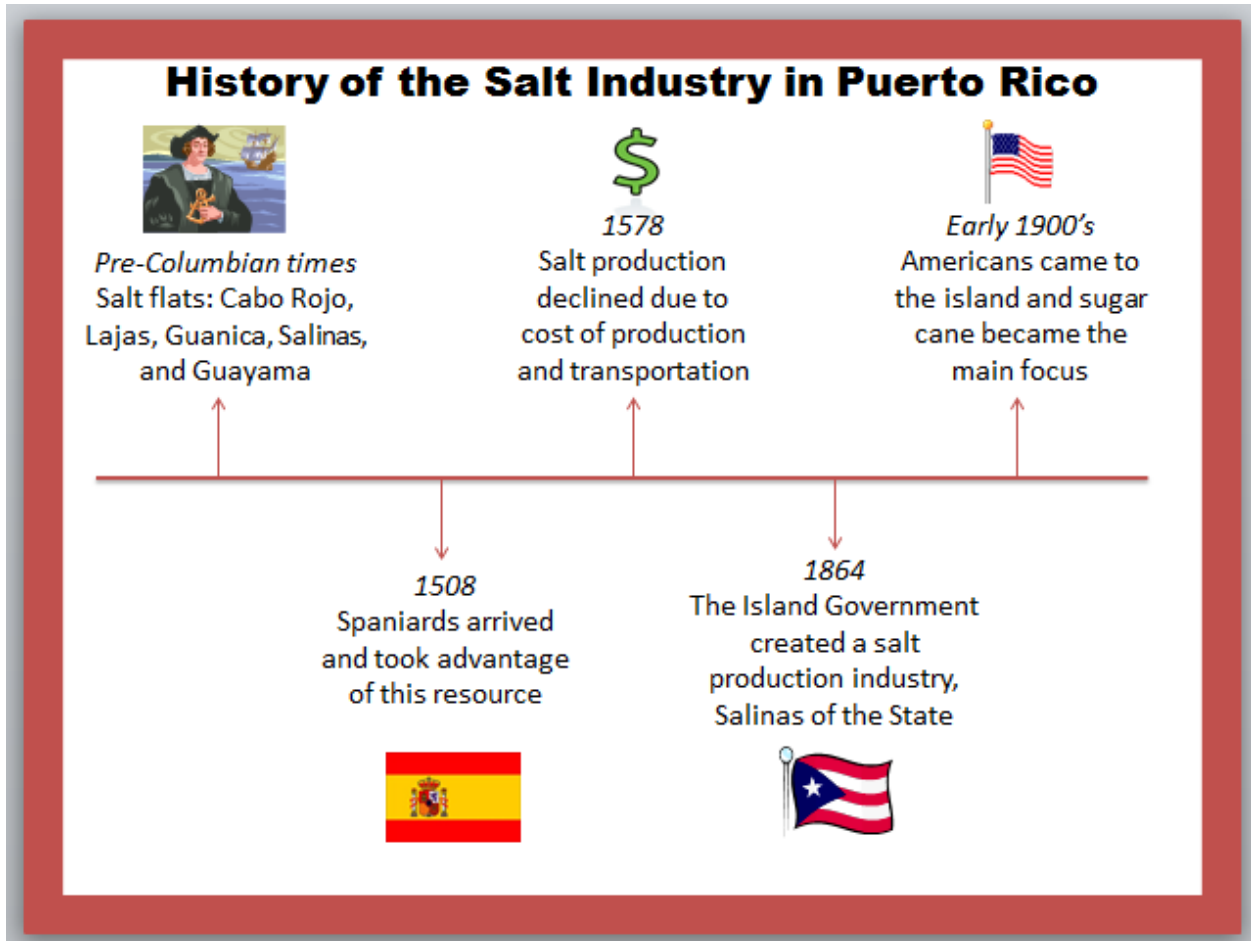

Figure 22: Salt Production History (Lebrón Rivera, 2011)

The information used to develop this educational visual can be found in Section 2.2 of the literature review “History of the Salt Industry in Puerto Rico”. After the visitor has viewed the first bird watching station, they would be able to proceed to the motor house area. This location would have information on the historical significance of the salt industry in Puerto Rico. This information is presented in a time line fashion Figure 23 to develop concise thoughts so that the reader can easily absorb the information without feeling overwhelmed. The material is also

provided with a small relevant image such that the information can be related to an image and better remembered.

Information on salt production history is essential in conveying the purpose of restoring the salt flats and in educating visitors on the past operation of the salt flats. This educational visual would be one of the first educational visuals available to visitors as they pass the motor house. Through presenting the history of the salt industry first, the rest of the site will again be put into context.

4.2.2.2.4 Salt Production Process

Salt Production

Steps:

1. The ponds are flooded either naturally or with mechanical systems
2. The dams are closed
3. The sun evaporates the water (time needed depends on the size of the pond)
4. Salt crystals fall to the bottom of the pond and the remaining water is drained
5. The salt layer is scraped off the bottom of the pond
6. Sold and used for swimming pools, ice melting formulas, soil amendments, and farming

Historic Fun Facts:

- Brought salt to the shore where salt merchants would pay 25C / bushel
- Sold and used domestically, in hospitals, in bakeries, and for the military



Salinas Fortuna 1996

Figure 23: Salt Production (Lebrón Rivera, 2011)

The information used to create this educational visual can be found in Section 2.3 of the literature review, “Salt Flats Areas”. After presenting history of the salt industry, the actual salt

production process is explained. This information provides the overview of the process to help create perspective for later presented information. This educational visual incorporates both the history and the actual development of the process. The integration in history allows for the salt production process to be presented after the history educational visual.

4.2.2.2.5 Salt Production Specific to Salinas Fortuna Salt Flats

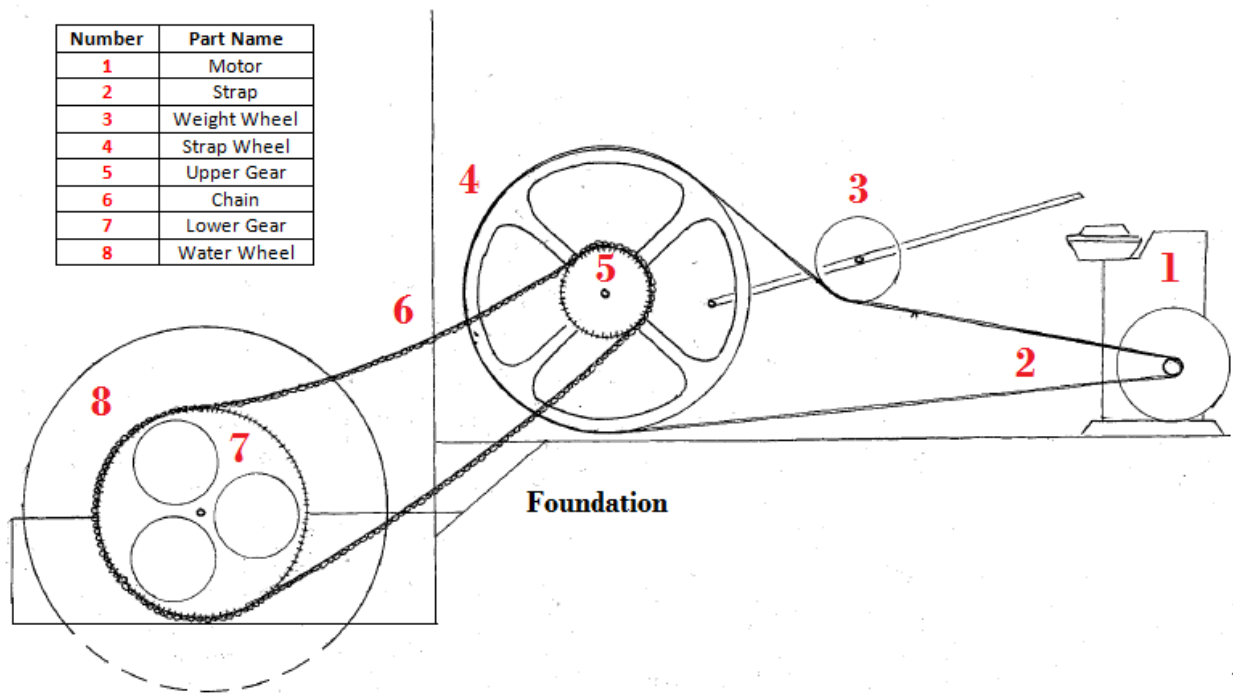

Figure 24: Salt Production Machinery in Salinas Fortuna

The information used to develop this educational visual is located in Section 2.3.1.3 of the literature review, “Salinas Fortuna Salt Flats in La Parguera Nature Reserve”. The educational material would become more specific to Salinas Fortuna with the transition from the general salt production on a salt flat to the type of system used to operate that salt production process. The “Salt Production Machinery in Salinas Fortuna” visual in Figure 25 includes a diagram of the water moving system visible inside the motor house. Each visible part on the diagram has a number associated with it, numbered upwards from 1, and this number would

correspond to a number on a part located on the actual system. This requires Fideicomiso to either paint the number directly onto the machine part or to install a small sign next to that part with the identifying number.

An option to increase visitors' hands on experience would be to develop interactive lighting display. The numbers on the diagram above would be linked to a button system. Questions could be incorporated to quiz the visitor on the part locations. After being asked to identify a part, the visitor could confirm their answer using the button with the corresponding part name. This button would in turn light up the number on the diagram, which would identify the location of the part in question.

The concept behind this presentation would be to increase the reader's involvement with learning about the salt production system. The reader would be able to look at the diagram and then at the system visible before them and identify where in the process that machine part is, what it is connected to, and what it looks like in reality. This stimulates interest in subject matter and challenges the reader to become involved in learning about the process more than they would be involved if the reader were simply looking at a diagram of the system (Singh, 2000).

This educational visual has a small description of the process, but the main focus is the drawing and system interaction because writing will not effectively be able to inform the reader of the process that occurs from the motor spinning to the wheels spinning. This educational visual would be stationed in front of the main window that will be used to view the water moving system.

4.2.2.2.5.1 *Diagram of Water Moving System Solidworks*

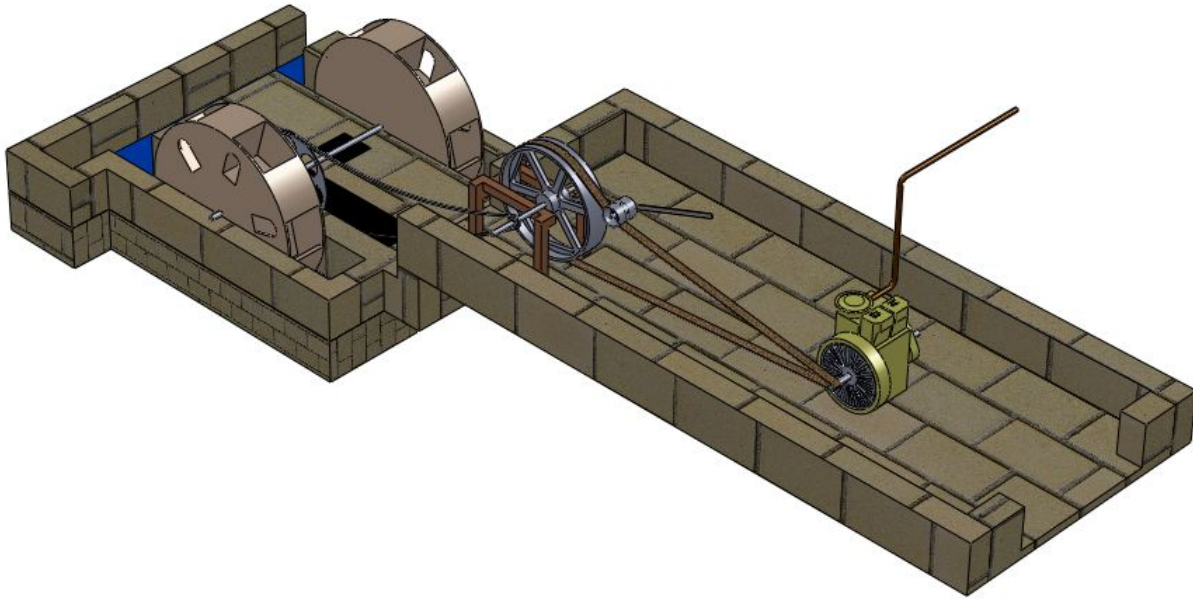

Figure 25: Diagram of Water Moving System Solidworks

To augment the 2-D exploded view of the water moving system, a 3-D display of the water moving system will also be available to visitors. This 3-D model will be viewed from a monitor that is fashioned to the side of the motor house that displays the water moving system to visitors. Due to the lack of electricity at the Salinas Fortuna site, the monitor would be expected to be connected to a solar panel system located on top of the motor house roof (or canopy roof). A more in-depth explanation of solar panel operation specific to the salt flats is located later in Chapter 6.

The display itself would have a 3-D model of the water moving system with the parts moving as if the system was operating. This will create an enhanced visual for visitors because they will be able to see a simplified version of the system, increasing their ability to understand how the system and parts operate. The model will move on a looped circuit so that the movement is constant and ensure that every visitor will be able to see the model in operation and gain the necessary understanding of how the system functions.

The limitation of this methodology was that Fideicomiso does not have the SolidWorks program to manipulate the created file. Our team addressed this limitation by developing a video file that included the water moving parts in motion. This file was saved to a separate file so that Fideicomiso could use it on site.

4.2.2.2.6 Salinas Fortuna Salt Flats

Salinas Fortuna Salt Flats

1884 Las Salinas de Lajas consisted of 269 acres and 20 crystallizing ponds. The land was granted to Don Ulises Lopez. Lopez sold pieces of the land to many people overtime. Throughout the various owners the land obtained the name Salinas Fortuna.

1996 the Fideicomiso acquired the land as part of the plan of acquisition of the Natural Reserve of La Parguera in Lajas.



Salinas Fortuna 1996

Today Las Salinas Fortuna consists of 214.12 acres and only 7 evaporation ponds.

Figure 26: Salinas Fortuna Salt Flats (Lebrón Rivera, 2011)

The background information used to create this educational visual can be found in the literature review under Section 2.2 “History of the Salt Industry in Puerto Rico”. After observing the water moving system inside the motor house, the boardwalk system would break into two

paths: one that leads further into the mangrove ecosystem to the south and the other further into the salt production system to the west of the motor house. Visitors that continue further into the salt production system would be able to see educational visuals on the Salinas Fortuna salt flats, such as the visual in Figure 27. The boardwalk system winds around the motor house to the west, guiding visitors to the back of the motor house where they can view the water wheel. If Salinas Fortuna is creating salt at that point and time, visitors would be capable of observing the water being transferred from sluice to the canal that will carry the water out to the salt flats area.

The boardwalk would carry visitors over the main canal that leads up from the coast and along the secondary canal bringing water from the system out to the salt flats. The signage located along this path would highlight specific steps in the salt production process. The Salinas Fortuna Salt Flats would start this salt production walk with an overview of the salt flats and inform people on what they can expect to see as they walk along the path. This educational visual provides concise information that informs the reader on how the salt flats have changed from past operation to the condition that they are in currently. The provided picture provides the historical context of the salt flats and allows visitors the opportunity to compare how the salt flats used to look to how they currently look.

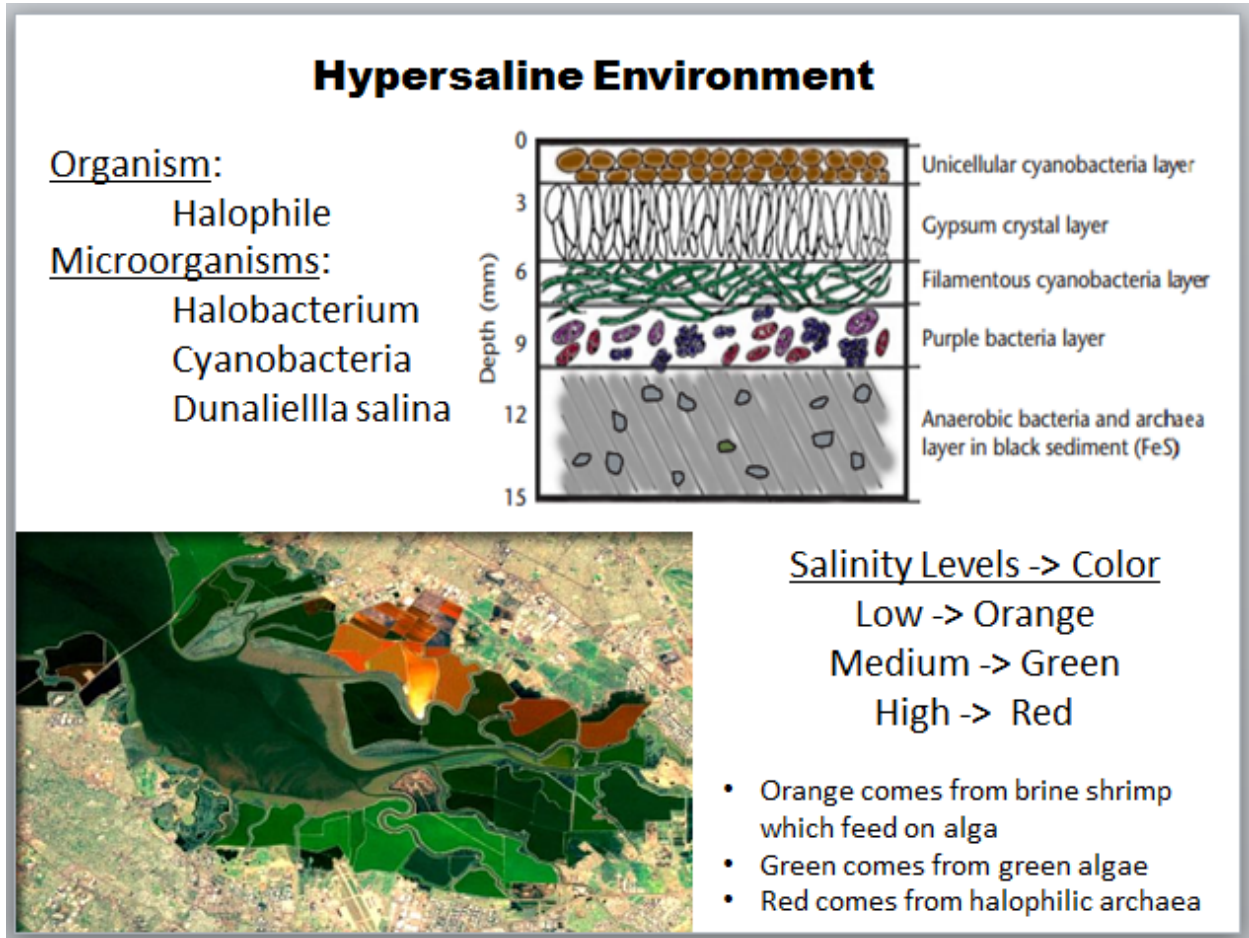

Figure 27: Ecosystem Diversity of Salinas Fortuna (DasSarma & DasSarma, 2012) (Kite Aerial Photography, 2010)

The information used to create this educational visual is located in Section 2.3.1.1 of the literature review, “Saline Environment”. While Visitors are walking along the boardwalk systems, either to the west of the motor house or to the south into the mangrove area, educational visuals will be made available that have descriptions on the types of ecosystems they are passing or the types of plants that might be visible. An example of the educational visuals that could be visible is the “Ecosystem Diversity of Salinas Fortuna” shown in Figure 28. This sign has very limited written words and instead relies on visuals to help describe the types of ecosystems present. In this situation, visuals help to convey to the reader the process that is occurring on the microscopic level thus providing them with more insight into the environment than they could

have on their own. This sign also explains how the bacteria help indicate when salt is ready for harvesting based on the color of the salt water concentration. If the beds are filled with water, visitors will be able to observe the real life application of the material provided and indicate where in the process the water concentration is.

This further augments the visitors experience and helps them become involved in the production going on around them. Presenting visuals is an effective way of ensuring that the reader understands the information and will be able to remember that information later due to pictures providing more visual stimuli than simply writing alone (Singh, 2000).

Chapter 5: Material Compilation

This chapter addresses our second objective: to research and select least impact materials for implementation and use in future visitor infrastructure. The overall goal for Fideicomiso is to restore Salinas Fortuna for future visitor education. There is no existing visitor infrastructure on site and therefore no foundation for materials selection. This chapter will detail the types of materials available on the local, imported, and least impact level and will rank these materials based on various properties, such as the property of pollution control or costs. Chapter five includes the methodology for achieving the second objective as well as material recommendations that should be used for the various forms of visitor infrastructure that Fideicomiso could implement in the future.

5.1 Methodology for Material Compilation

5.1.1 Case Study of Cabo Rojo Salt Flats for Materials Compilation

The case study of Cabo Rojo salt flats for materials analysis was heavily reliant on visual observations. Our team participated in a tour of the Cabo Rojo nature refuge facilities where we were able to observe established visitor infrastructure in the environment. Our group focused on the types of materials used to construct each structure, such as boardwalks, bird watching stations, and visitor center. Our group also analyzed how the materials were responding to the location they had been implemented, specifically if that material was warped or deteriorating from exposure to the elements. From our initial observations of an established nature protected area, our team began to develop our own compilation of usable material options. Our group also interviewed Oscar Diaz to gain knowledge on material recommendations and regulations.

5.1.2 Materials Compilation

Materials selection for building infrastructure is highly important for determining structural integrity and impacts. The expectation for this project is to open the salt flats to the public and provide people with the opportunity to learn about the historical salt production process of Puerto Rico. Our group, therefore, examined various types of materials that could be used for rebuilding the motor house and for implementing visitor infrastructure in the future. The materials selected were tailored for the motor house design, the visitor boardwalk system around the salt flats, bird watching stations, and a visitor center. While selected materials were different for each building type, the process for material selection was the same. Each material choice was dependent on the type of material, structure for implementation, environmental friendliness, cost of that material, and the location which the material could be obtained.

5.1.2.1 Research Material Options and Comparison

Our group began the materials selection process by researching various materials. As previously stated, Fideicomiso strongly supports creating as little of an impact on the environment as possible. This interest of Fideicomiso drove our research and guided our final materials selection. To be able to select which material was effective for each building infrastructure, our group performed online research on various material options.

Our group also spoke with Fideicomiso employees to obtain any recommendations they might have, as well as information on materials that have already been implemented in other nature reserves. John (Fideicomiso construction manager) provided our team with information based on the types of materials that were predominantly used in Fideicomiso properties and the types of materials implemented for restoration projects.

The final culmination of materials information was placed into a Microsoft Excel file, which included the name of the material, the recommended use of that material, whether it had heat island impact, recycled, low emitting, rapidly renewable, pollution protectant, biodegradable, water resistant, recyclable. The criteria for material analysis were based on established LEED standards as well as Fideicomiso's experience with materials implemented on their other properties. Materials were separated based on material type and were divided into sections of: wood, wood alternatives, wood sealants, lubricants, foundation, sound proofing, and materials currently in use on Fideicomiso sites. The final Microsoft Excel file helped guide our group's infrastructure design and helped to develop the final costs of each material option.

5.1.2.1.1 Salinas Fortuna Observations and Conversations

To help gain perspective into the types of materials available and used at Salinas Fortuna, our group visited the site to take field notes on the current condition of the buildings and available materials. Our group spoke with Fideicomiso employees during these visits to obtain information on the types of materials that they would like to see used at Salinas Fortuna and problems that they have observed with the existing materials that should be improved. From this, our group was able to form recommendations based off of what is currently successful, and what is not, at Salinas Fortuna.

5.1.2.2 Environmentally Friendly Ranking System

When ranking the materials based on environmental friendliness attributes. We used Leadership in Energy and Environmental Design (LEED) Green Building Rating System to rate each material based on these attributes (Meisel, 2010). Due to the Fideicomiso's interest in using least impact materials the majority of materials are LEED certified. The materials that were LEED certified were ranked based on the LEED Green Building Rating System.

To provide an overall ranking of the environmental friendliness of each material our group used Microsoft Excel to sum the amount of attributes each specific material had according to LEED. This was indicated in a table based on an X that it had that property or a blank box that it did not have that property. Our group then divided this number by eight, the total amount of environmentally friendly attributes. Finally, this number was multiplied by 100% to produce the percentage of environmentally friendly attributes associated with each material. An example of the environmental friendliness of the material oak is shown below is Table 2.

Name	Environmental Friendliness								%
	Heat Island Impact	Recycled	Low Emitting	Rapidly Renewable	Pollution Protectant	Biodegradable	Water Resistant	Recyclable	
Oak			X	X					25

Table 2: Environmentally Friendly Ranking

The materials were then put into a color coded system, shown in Table 3, based on the use of each material. Pink represented materials which could be used inside the motor house as supports or decoration while green displayed materials used for infrastructures such as the motor house, bird watching stations, visitors’ center, and the boardwalk system. The color grey was used specifically for wood sealants which could be applied to any of the above wooden infrastructures. Blue represented materials used for the maintenance of machine parts, and finally, orange showed materials used for foundations and pavement.

Wood Sealants
Machine Parts
Parking Lot
Inside the House
Infrastructures
Foundations

Table 3: Color Coded System of Materials Matrix

There are some materials listed in the matrix which our group was unable to rank based on the environmental friendliness qualifications. One type of material Fideicomiso requested we

research was sound proofing materials. Many sound proofing materials are created from new technology and therefore are not yet certified by LEED. In order to provide more sound proofing options, our team researched products produced by the Pinta Acoustic Inc., the company that makes Bioline, a LEED certified sound proofing material. For this reason, these materials were marked as “Not Applicable” and were not included in the environmentally friendliness section of the matrix.

Another section of the materials matrix we were not able to rank was the section of currently in use materials. This section of the matrix was used to gather materials that are currently being used on other Fideicomiso properties. These materials are not LEED certified so we were unable to rank the environmental friendliness of each. However, their past implementation at other properties provided our group with some support for recommendations.

5.1.2.3 Individual Material Costs

In order to have fully developed material recommendations, the costs of recommended materials were researched. This cost development focused on the types of materials used and the recommended implementation of that material. Current day market values of materials were used for individual costs, which were obtained from specific companies that Fideicomiso could contact in the future. Companies that sold specific materials were contacted on the phone or through email and the costs per material were converted to costs per unit in the International System of Units (SI). This cost matrix was developed in Microsoft Excel and was broken into sections based on the type of material used (such as wood), the name of that material, the cost of that material per unit sold, and the contact to obtain that material. The cost matrix was devoted solely to materials and did not include topics such as the costs of labor or building tools. This cost matrix included various options of materials as well as various locations to implement these

materials thus providing Fideicomiso with varying cost options for different structures. We were able to determine the appropriate use of each material based on LEED suggestions.

5.1.2.4 All Encompassing Ranking System

To generate final recommendations on which materials to use throughout the site, our team gathered the opinions of Fideicomiso employees. Fideicomiso staff were given time to come to an agreement on the ranking characteristics of each material they found to be most important. The characteristic which was ranked most important was the type of material. As Fideicomiso's construction manager, John, explained it is important to maintain the materials currently in use on site. Due to this, currently in use materials ranked as the number one type of material on the matrix.

The characteristic that ranked second for Fideicomiso was the environmental friendliness of each material. Our group looked specifically at the color coded system which displays the use of each material and then determined which one had the highest percent of environmentally friendly attributes. The third ranked characteristic was the cost of each material. The costs in the matrix also followed the color coded system to allow our team to determine the cheapest material that could be implemented for different uses. The final characteristic was whether or not the material was imported. Fideicomiso expressed interest in using materials which are located on the island. For this reason the materials which are local were ranked higher.

Table 4 displays the characteristic, the rank, and the amount of points for each given by Fideicomiso. This scale was used to calculate the final all-encompassing ranking of the materials. Any materials which were currently in use received four points. Evaluating each separate recommended use, the material with the highest percentage of environmental friendliness received three points and the material with the lowest cost received two. Any

material which was manufactured locally earned one point. Finally, the points were totaled and the materials with the highest score from each section of recommended use were the materials used for suggested implementations. Some materials had a tied score for their specific recommended use so both were suggested.

Characteristic	Fideicomiso Rank	Points
Type - Currently in Use	1 st	4
Environmental Friendliness - Higher	2 nd	3
Cost – Lower	3 rd	2
Location - Local	4 th	1

Table 4: Materials Ranking System

5.2 Results and Discussion for Materials Compilation

5.2.1 Case Study of Cabo Rojo Salt Flats for Materials Compilation

A visual analysis of the Cabo Rojo refuge revealed that the site has put great effort into minimally impacting the environment. The Cabo Rojo refuge had a boardwalk system that ran from the visitor center, through the mangrove area, and around the salt flats. The boardwalk and bird watching stations were all made with generic white pine kiln dried and without chemical alterations. The bird watching stations specifically had nails and screws in various locations to hold the wooden structure together. In the places where there were nails instead of screws, the boards had begun to warp slightly and pull up in the corners, showing that the warm weather of the area can potentially deform materials more quickly if they are not properly secured. The boardwalk system had no hand rails, thus eliminating the potential for railings to degenerate from human contact and potentially cause harm to visitors such as wood splintering.

During our interview with Oscar Diaz, he explained that 10% of the materials selected needed to be recyclable and that the source of materials cannot be located more than 805 kilometers away from the site of implementation. Oscar explained that this is difficult to achieve

in Puerto Rico because of the limited resources on the island as well as its distance from countries that supply necessary sources.

5.2.2 Material Compilation

5.2.2.1 *Research Materials and Comparison*

5.2.2.1.1 Interview with Fideicomiso Engineer- Construction Manager John

Our interview with John (Fideicomiso construction manager) provided insight into how Fideicomiso's properties are restored or refurbished after they have been purchased. John revealed that the process is very meticulous and that it is their goal to maintain the historical significance of the entire site. This often meant that each restoration project employed the use of the same materials that had been originally used on site. John also provided our group with basic materials that he and his workers use; typically the materials are very minimalistic and tend to be generic wood, such as standard pine, and basic steel.

5.2.2.2 *Material Matrix*

The final accumulation of our materials based on research, interviews, and our observational case study are listed in Table 5. This includes the type of material, the name of the material and the recommended use. Table 6 displays the all-encompassing results of the materials. Due to the size of the table, a complete view of the information can be found in Appendix N. For more detailed descriptions of the LEED certified materials, refer to Appendix O.

Material	Name	Possible Uses
Wood	Bamboo	House, Stations, Center, Boardwalk
	Reclaimed Indonesian Hardwood	House, Stations, Center, Boardwalk
	Mahogany	House, Stations, Center, Boardwalk
	Oak	House, Stations, Center, Boardwalk
Wood Alternatives	Geo Deck	House, Stations, Center, Boardwalk
	i-plas	House, Stations, Center, Boardwalk
	Kirei Board	House, Stations, Center, Boardwalk
	Trex	House, Stations, Center, Boardwalk
	Natural Fiber Boards	House, Stations, Center, Boardwalk
Wood Sealants	Rubio Monocoat Oil Plus	Structures made of wood
	PolyWhey Natural Wood Finish	Structures made of wood
Lubricants	SoyGrease EP Premium	Machine Parts
	SoyGrease HiTemp	Machine Parts
	TempFlex 0 to 100	Machine Parts
	SoyGrease Semi Truck Fifth Wheel	Machine Parts
	BERUGEAR UWS FG 34-00	Machine Parts
Foundations	Dirt Glue	Foundation of Structures
	Eco-Cement	Foundation of Structures
	Granite Crete	Foundation of Structures
	Gravel Pave	Parking Lot
	Drivable Grass	Parking Lot
Sound Proofing	Decibel Drop	Inside House
	Barrier	Inside House
	Composite	Inside House
	Valueline Baffles	Inside House
	Bioline	Inside House
Currently in Use	Pine	House, Stations, Center, Boardwalk
	Ausubo	House, Stations, Center, Boardwalk
	Teak	House, Stations, Center, Boardwalk
	PVC Wood	House, Stations, Center, Boardwalk
	Sand	Foundation of Structures
	Concrete	Foundation of Structures

Table 5: Materials Purpose Matrix

Name	All encompassing	
	Points	Final Recommendation
Bamboo	3	
Reclaimed Indonesian Hardwood		
Mahogany	1	
Oak		
Geo Deck	2	
i-plas		
Kirei Board	3	
Trex	3	
Natural Fiber Boards	3	
Rubio Monocoat Oil Plus		
PolyWhey Natural Wood Finish	3	Wood Sealants
SoyGrease EP Premium	3	Machine Parts
SoyGrease HiTemp	2	
TempFlex 0 to 100		
SoyGrease Semi Truck Fifth Wheel	3	Machine Parts
BERUGEAR UWS FG 34-00		
Dirt Glue		
Eco-Cement	3	
Granite Crete	2	
Gravel Pave	3	Parking Lot
Drivable Grass	2	
Decibel Drop		
Barrier	2	
Composite		
Valueline Baffles	2	
Bioline	3	Inside the House
Pine	4+1 = 5	Infrastructures
Ausubo	4+1 = 5	Infrastructures
Teak	4	
PVC Wood	4+1 = 5	Infrastructures
Sand	4+1 = 5	Foundations
Concrete	4+1 = 5	Foundations

Table 6: Materials Matrix Score Results

From our materials matrix we were able to conclude on final recommendations based on our ranking system consisting of characteristics such as type of material, environmental friendliness of each, the cost, and finally the location the material can be purchased from. Our conclusions were split into recommended uses. Out of all the materials recommended to use inside the motor house, we concluded that Bioline best encompassed all desired characteristics. Bioline would most effectively be implemented in the ceiling of the motor house due to its sound proofing properties working to help eliminate operational noise of the motor (Meisel, 2010).

When concluding on materials for machinery maintenance, we found SoyGrease EP Premium and SoyGrease Semi Truck Fifth Wheel to be the best options (Meisel, 2010). Based on our observations of the Salinas Fortuna facilities, the current lubrication method involves the use of the metal chain of the system passing through an oil well. The system self lubricates, however a great deal of excess oil leeches out from this well and settles on the surrounding area. The current system pollutes the surrounding environment and Fideicomiso employees expressed that they would like to see new options to lubricate the system. SoyGrease products are environmentally friendly and would help lubricate and maintain the chain system without polluting the surrounding environment, eliminating the need for the oil well lubrication method.

The material best for use in the foundations of structures is concrete that uses sand as the aggregate filler. Concrete is a cheaper material that is already used on site in the foundation of the motor house. John (Construction Manager) explained that concrete had been successful in implementations on other properties he has restored and typically the material used for foundation purposes.

The best wood sealant is PolyWhey Natural Wood Finish. This material could be implemented on any wooden surface to help protect the wood, without leeching harmful chemicals out into the environment after implementation (Meisel, 2010).

The best option for the parking lot is Gravel Pave. Gravel Pave can be installed into the ground and does not employ the use of fossil fuel dependent asphalt. This material also allows for water to pass through the material, acting as a natural filter for the water and reducing potential sources for water pollution.

The material recommended to use for the different infrastructures (boardwalk, bird stations, visitors' center, motor house) has three options which ranked highest according to our matrix: pine, ausubo, and PVC wood. Typical woods, like pine, reduce the costs of building structures and are readily available in many stores, should replacement be necessary over time. Ausubo is another strong wood, however it is more expensive. Ausubo will effectively last and it has natural oils that help maintain its structural integrity. PVC wood is a wood alternative that helps reduce the dependence on natural resources, such as trees, and employs the use of recycled material.

Our conclusions on the materials above were dependent on our ranking system and on the situation they can be used in. Although these are our recommendations the complete table of materials is presented in Appendix N to offer Fideicomiso with multiple options. We did not want to limit the options and depending on the situation Fideicomiso can choose between different materials which are listed in detail.

It is also important to note that our material recommendations are based on a basic analysis. Due to the limit of time and the other deliverables that this project developed, our group was not able to address every material that might be used on the site. Our research and discussion

with Fideicomiso staff suggested that many Fideicomiso properties used similar materials and that the materials that were used were often the same types of materials that had been used for decades. The purpose of our material recommendations was to provide Fideicomiso with different options that they might not have considered in the past, especially the new environmental alternative options, and could potentially implement in the future.

Chapter 6: Restoring vs. Replacing the Salt Production System

This chapter introduces the importance of salt and the mechanisms behind the salt production system. This chapter also explains our methodology for evaluating the current system, including a 60 year old motor. This diesel dependent motor emits excessive amounts of noise, which can potentially disturb the surrounding ecosystem and persons who come to visit the site. The final topic that our project analyzes is the issues associated with restoring this motor and the system to which the motor is attached. Recommendations will be presented that will address full system restoration, partial system restoration, and full system replacement. In doing so, our group will provide Fideicomiso with several options for improving the current system and help them reach their goal of opening up Salinas Fortuna for the education of future visitors.

This chapter will be separated into six project topics, each of which will include methodology, results, and discussion. These topics include a case study of the Cabo Rojo salt flats, gaining an understanding of water moving mechanisms and costs of Salinas Fortuna, environmental alternatives, a noise analysis, full motor replacement, and a motor analysis.

6.1 Case Study of Cabo Rojo Salt Flats for Salt Production Analysis

The final portion of our Cabo Rojo salt flats case study focused on analyzing the water moving system, noise pollution of that system, and methods to evaluate how to reduce noise pollution from the water moving system.

6.1.1 Methodology of the Case Study of Cabo Rojo Salt Flats for Salt Production Analysis

Through our case study and interview with Oscar (Cabo Rojo salt flats manager), we gained information on the current water moving system. This includes how the system operates,

the type of maintenance performed, environmental considerations, and the noise that the system creates. The study of Cabo Rojo salt flats compared how similar, or different, the system in Cabo Rojo is to the system in Lajas. Our group augmented any observations with an interview of a salt production employee. This interview provided insight to a functional salt production process.

By observing a functioning water moving system, our team's recommendations for the restoration or replacement of the Salinas Fortuna water moving system were greatly enhanced. The visit was also documented with pictures, sketches, and written observations, specifically their motor, evaporation ponds, and visitor infrastructure.

While on site, our group also compared the noise created by the pump on the Cabo Rojo salt flats to the motor on Salinas Fortuna using the Precision Sound Level Meter provided to us by Fideicomiso. Our notes on the noise created from a functional water moving system aided us in our noise analysis of the motor on Salinas Fortuna. Our group also observed if any sound proofing materials or muffling systems were incorporated into the salt production system. This helped our group understand effective ways to reduce motor noise, potentially without having to alter the system. Information gained from the Cabo Rojo salt flats helped to determine how the successes and failures of one salt flat could be incorporated into the design of Salinas Fortuna. The case study provided a balance between technical data and life experiences, such that the full dimensions of the water moving system restoration were analyzed.

6.1.2 Results and Discussion of the Case Study of Cabo Rojo for Salt Production

Analysis

6.1.2.1 Interview with US Fish and Wildlife/Cabo Rojo Refuge Manager, Oscar Diaz

During our interview with Oscar (Cabo Rojo salt flats manager), he provided our group with information on the interactions between a nature reserve and the US Government as well as

information on the overall salt production environment of Cabo Rojo salt flats. Oscar explained that under the 1997 National Wildlife Act, nature reserves must abide by six national priorities, also considered regulations: hunting, fishing, education, interpretation, photography, and observation. Abiding by these regulations, such as prohibiting hunting on a nature reserve or promoting education through tours and materials, allows for a reserve to be established and to open to the public. The Cabo Rojo salt flats have been an established reserve for many years but the actual salt production of the reserve has been operating for nearly 500 years. Once the Cabo Rojo salt flats became an established reserve, limitations were placed on the salt production system.

Oscar also elaborated on the type of pump system used at the Cabo Rojo refuge and provided our group insight on how the system differs from Salinas Fortuna. Oscar Diaz clarified that the system for filling the pond at the Cabo Rojo salt flats is completely reliant on the natural tides. A dam is opened near the water which allows for water to naturally fill into the beds. Water remains in the ponds naturally, where the bacteria of the pond will ferment the water to a pinkish color, which indicates that the salinity has increased enough to transfer the water to the evaporation ponds. At Salinas Fortuna, the water must be mechanically transferred to ponds, requiring more manmade manipulation to operate the system. However, Cabo Rojo's system was still dependent on a mechanical system. A 10 hp diesel pump transfers the high salinity water from the natural ponds to wooden crystallization boxes where the water precipitates out. Oscar also stated that the water moving system is not disruptive to the environment and that its impacts are minimized from only operating the pump a couple hours a day for a couple days in a salt production season.

6.1.2.2 *Cabo Rojo Salt Flats Tour Observations*

While on a tour of the Cabo Rojo salt flats, we were able to interview an employee directly involved in the salt production system. From this interview we gained information on the salt production process used on the Cabo Rojo salt flats. There are 12 operational ponds that are filled using ocean water from canals. The water will sit for one month and once the color turns pink, 1.5 inches of salt is created. The excess water is then extracted using smaller pumps; and a manmade channel guides the water back to the lagoon. Finally, trucks collect the salt and a larger pump is used to clean the ponds.

The employee explained that this process requires the smaller pumps to run every 30 days and the larger pump to run every 50 days. While on site we were able to conduct a noise analysis of the pump used. Table 7 displays the results of the noise analysis.

Distance from the pump	dBA
5 m	87
30 m	70
50 m	61

Table 7: Noise Analysis of Cabo Rojo

This noise analysis shows that even in an established salt production location, noise of operation can still be loud. The main reason that the Cabo Rojo salt flats area has been able to perform this operation is because of the limited use. The protected bird area is also located on the other side of the property, further than 50 m, and it can be assumed that the noise would greatly diminish once it reached protected areas. This distance was the key difference between Cabo Rojo salt flats and Salinas Fortuna. The motor operating at Salinas Fortuna is located in a shack directly next to the marsh areas where birds nest. Sound has a greater opportunity to affect the birds at Salinas Fortuna than at the Cabo Rojo salt flats because of the increased proximity between noisy machinery and bird nesting grounds. Due to this, our group was not able to find a

useful form of sound proofing from the Cabo Rojo facilities because the system did not require one.

6.2 Gain Understanding of Water Moving Mechanism and Costs of Salinas Fortuna

Based on our observations of the Cabo Rojo salt flats, we analyzed the salt production system on Salinas Fortuna to highlight the differences between the two salt flats. This specifically included the water moving mechanisms and costs associated with this system.

6.2.1 Methodology Used to Gain an Understanding of Water Moving Mechanism and Cost of Salinas Fortuna

In order to restore the water moving mechanisms, the original motor was first analyzed to determine its present condition. Within the first week of being in Puerto Rico our group traveled to the motor house location to observe the condition of the motor firsthand. At this point, a visual observation was made of the motor. This analysis included written observations on the motor's type, model, and condition and also documented the condition of the water wheel system attached to the motor that helps to perform the salt production operation.

6.2.1.1 *Salinas Fortuna Interviews*

To gain insight on how the water moving system functioned in working condition, we spoke with Jose (area coordinator). The interview provided us with information based on how much maintenance the system required as well as any personal recommendations he had to improve the operation of this system. During this interview, our group was also able to see the motor in operation to determine how it worked.

6.2.1.2 Maintenance Parts Costs and Availability Compilation

Our team contacted the motor's manufacturer, Lister Petter. During our interview with Lister Petter, we were able to gain an understanding of how the existing motor should be maintained and whether the parts are still available. We also joined several online stationary engine forums and museum groups. These sources provided information on the type of motor, how old it is, recommendations on how it should be used and maintained, and the availability of parts and labor. Our team compiled a general list of the specific motor parts that would need to be maintained for the existing system and our alternative recommendations. This list included the main wear parts of the motor and the costs of each. These costs were based on current market values and were found through contacting the motor's manufacturer.

6.2.2 Results and Discussion of Gaining an Understanding of Water Moving Mechanism and Costs of Salinas Fortuna

The salt production system of Salinas Fortuna used to rely on the natural flow of water from the ocean's tides as well as a mechanical system that moves the water from one elevation to another. A mile long canal extends from the ocean, through an expanse of mangroves, eventually reaching the established salt production system of Salinas Fortuna. A man-made sluice branches off the canal and fills with sea water as it advances from the ocean. A sluice gate runs across the sluice to cut water off from entering the system unnecessarily. Two large water wheels take the water from the sluice and transfer the water to a higher canal system that leads directly to the evaporation ponds. This wheel system is dependent on the operation of a manual starting Lister diesel motor. This motor, during operation, spins a driveshaft that rotates a mechanical advantage gear ratio belt and chain system, which in turn rotates the heavy water wheels. Without the

operation of the motor, the system would not move and water would not be lifted to fill the evaporation ponds.

This entire system, aside from the motor, is inoperable. The wooden parts have not been maintained over the years and have started to splinter, peel, and fall apart. The steel parts that make up the wheels and chains are severely rusted and cannot be used without either cleaning the parts or replacing them. The system, overall, is intact but it is not able to operate without properly cleaning, replacing, and maintaining the system.

6.2.2.1 Interview with Motor Resources

To learn about the existing machine (HA2) and gather information regarding its future, the group conducted phone and email interviews with the manufacturer Lister. Unfortunately very little information was provided by Lister, making us extend our search into two online forums and a diesel engine museum and restoration company. From the information gathered, the general consensus is that antique Lister diesels, and other stationary diesels of the time period, are renowned for their exceptionally long life span and minimal part failures. With required refurbishment, the current motor in Salinas Fortuna could be anticipated to last up to and beyond another 40 years.

From our observations of the motor start up, the motor clearly fit the criteria for a well starting and functioning machine. The motor started easily after standard prep procedures, ran smoothly at various revolutions per minute, maintained proper exhaust color, and lubrication oil appeared to not contain water or fuel oil. The engine museum, Realdiesel, also provided us with information regarding the repair or restoration of the HA2. They are able to provide all necessary replacement parts or can take the machine for a total overhaul or swap replacement. Realdiesel noted the only potential issues in a complete overhaul would be possible severe crankshaft wear,

and the most expensive alterations would be the installation of a ring gear for the proper starter to fit the motor aperture. We were also told that, while the machine will always be mechanically loud, operational noise issues can be resolved with a good silencer or muffler and tightening of any loose equipment. As far as the use of a biodiesel fuel supply, Realdiesel recommended against its use. They found from their repair experience that the available biodiesel varies enormously in quality with the less refined fuel causing intermittent operation issues, incomplete combustion, and filter clogging. The responses from motor companies and forums has lead our group to believe that full restoration of the system is possible, but can be costly depending on how much of the system will need to be cleaned.

6.2.2.2 Maintenance Parts Costs and Availability Compilation

After completing our interviews with various motor specialists, our group was able to compile a list of general motor parts that might need to be replaced should a specific part fail during operation. Table 8 below summarizes our team's findings and shows that parts are still available should Fideicomiso need them. The availability of parts further enforces that restoration of the system is possible and that the machine can continue to be maintained, should the need arise.

Part Name	Number	Cost (US Dollar)
Comprising Shells 5-1/D18	574-10310	90.06
Comprising Shells 8-4-26	574-10320	96.50
Connecting rod bolt nuts	27-4356	6.43
Small end (connecting rod)	5-1/D7A	45.03
Camshaft end-bearing	3155	23.16
Camshaft end cover bush	8-6-2	19.30
Wick type fuel filter	23/2288C	83.62
Decarbonizing gasket set	3-1	90.06
	6-1 and 8-1	57.90
Full gasket set	6-1 and 8-1	77.20
	12-2 and 16-2	109.36
Copper composite cylinder head gasket	23/2525	109.36
Piston ring set	10-4-18	38.60
Inlet/exhaust valve	8-1/C121	34.09
Inner and outer valve springs	11-3-219	23.16
Oil pump	574-10130	186.56
Fuel injection pipe	8-3-157	54.04
Fuel injector nozzles	16-2-023-00792	30.86
Fuel Filter	351-29760	6.30

Table 8: Motor Parts ("Lister CS Diesel Engine Parts,")

6.2.2.3 Interview with La Parguera Area Coordinator Jose

Our interview with Jose (area coordinator) provided insight on how the water moving system worked and the general maintenance that had been conducted to keep the system operational. Jose stated that the motor is a low maintenance machine, with costs never exceeding \$60 a year. Jose also pointed out that the motor was only started about once a month in order to ensure that it was properly lubricated. The plan for Salinas Fortuna is to have the motor operational consistently for several months in order to produce enough salt to show visitors. Jose predicted that maintenance costs would likely double due to the increased operation. He stated that the machine would require more fuel, more frequent lubrication, and increase in filter changes, all which would drive up maintenance costs. Jose also ran the motor at the different speed settings: idle speed and running speed. Through hearing the system in operation, our group

was able to perform a noise analysis of the motor at running speed in and around the motor house. Results for this analysis can be found in the next section.

6.3 Noise Analysis

While on site at Salinas Fortuna, our group observed that there was loud operational noise. Our group performed an analysis to capture the operational noise measurements and used the results to form sound suppression recommendations. The recommendations allow for a full system restoration.

6.3.1 Methodology of Noise Analysis

6.3.1.1 Effects of Noise on the Environment and Visitors

A major concern of Fideicomiso was the noise pollution caused by the current water moving system. The main obligation of Fideicomiso was to maintain the natural ecosystem of the area. Within La Parguera nature reserve, 117 species of animals are protected. Endangered species like the yellow-shouldered blackbird have been found to migrate to the shores of Puerto Rico and establish nests in locations like Salinas Fortuna (Méndez-Gallardo). One of Fideicomiso's main initiatives was to protect the endangered migratory bird species. As our background research showed, the noise associated with the water moving system could negatively have effected where the birds made their nests (Fideicomiso de Conservacion, 2013a).

The noise study also applied to humans. One goal of the reserve is to attract visitors; due to this, the motor should not make so much noise such that it will bother those visiting the location. We had to make sure that it did not exceed 120 dB, which is the sound pressure reading where noise can cause pain. We also made sure that no matter the distance from the

motor, the sound pressure level did not exceed 90 dB. This level of noise is roughly the sound of standing 1.2 meters away from a milling machine (Hansen).

6.3.1.2 Sound Pressure Test

To determine the noise currently created by the water moving system, we conducted instrumented tests using a Precision Sound Level Meter provided by Fideicomiso. It is manufactured by Bruel and Kjaer, type 2232, and serial number 1879384. It has property number 17017 of the Environmental Quality Board.

To determine how loud the motor was during operation, we performed tests in the area surrounding the motor and identified our coordinate origin as the motor house. We then collected sound pressure measurements five meters and 40 meters north of the house, and 30 meters and 50 meters east of the house. The measurements were taken 1 meter above the ground. From each of these locations we took two measurements: one while the motor was operating and one while it was off. Figure 29 below displays a visual layout of where measurements were taken.



Figure 28: Sound Test Distances

The sound pressure levels obtained from the meter were compared to the research of sound levels that animal species can live around without being affected. A control was also established from an ambient sound reading when the motor was not in operation. Any obtained values during operation were compared to the control as well as to determine how loud the motor was during operation.

Our team performed experiments to conclude if any existing infrastructure could be used to minimize the sound. One such experiment was performed through enclosing the operating motor in the motor house by closing windows and the door. Two measurements were obtained, one 5 meters north of the motor house and one 50 meters east of the motor house. These measurements were taken 1 meter above the ground as well. Another reading was then performed while holding down parts of the motor that were rattling during its operation, specifically the air filter.

6.3.2 Results and Discussion of Noise Analysis

Condition	Distance					
	Base (0m)	5m North	40m North	30m East	50m East	Exhaust opening
Off dBA	40	45	43	34	37	40
On dBA	93	80	56	63	50	86
Doors closed	NA	76	NA	NA	35	NA
Holding Down Air Filter	89	NA	NA	NA	NA	NA

Table 9: Sound Level Measurements from Salinas Fortuna

Results, displayed in Table 9, showed that inside the motor house, the noise reached around 93 dB(A). This sound did not carry very far into where the birds were located, 50 meters east of the motor house, the sound diminishing to around 50 dB(A). Our group also observed that the readouts, with doors and windows open, were higher towards the roadside, which was a path directly in line with the motor and the opening of the door. We noticed that towards the east, where the small windows were the only opening for the sound to directly travel out of, the sound was lower. We made the assumption that the wood was interfering with the traveling sound. In order to test this theory, an experiment was performed outside the motor house with the doors and windows closed. Our group found that when the motor was sealed inside the motor house, the sound diminished by 30% towards the bird marsh area and by 5% towards the road 5 meters in front of the motor house. During operation, our group had observed that the air filter on top of the motor was rattling with the vibrations of the motor as well. We performed a test inside the motor house while holding down this filter to reduce the rattling, and found that the noise was reduced by 4 dB(A) inside of the motor house.

The current operation of the water moving system's motor exceeds the environmentally friendly limit. The results from the noise analysis test, as seen in Table 9, summarizes the findings, shows that the current operation of the motor from inside the motor house is around 90 dB(A).

The goal was to quiet the motor such that the noise of the motor around the motor house did not exceed 50 dB(A). Through speaking with the US Fish and Wildlife contact, Oscar, and the Fideicomiso construction manager, John, our team was able to determine that noise above ambient sound can be detrimental to bird species. Both interviews produced similar discussions on noise and Fideicomiso personnel take extreme precautions to ensure that they are not creating noise when working on site. This is typically achieved through avoiding the use of machinery or through minimizing machine operation. As previously discussed in the motor house design section, 4.1.2.4, sound proofing material options can be incorporated into the motor house walls to help reduce the noise. Closing off openings, as the results from the noise analysis suggest, also can greatly reduce the noise caused by the current motors operation. In order to maintain the historical significance of the system, it is necessary to maintain the current operating arrangement.

The interview conducted with Jose (area coordinator) led our group to believe that the maintenance of the motor is minimal enough for the motor to possibly continue to operate smoothly. Jose explained that the motor has not needed to have any parts replaced and that in order to continue to use the motor; the only issue that needed to be addressed was the issue of noise. This option would call for a restoration of the motor that exceeds simply implementing sound proofing materials into the motor house design. The motor system itself has had many years of operation to become loose at the points where the legs of the motor connect with the ground, as well as between parts within the system. Taking the system apart and cleaning each part, replacing old washers and nuts with newer ones, and securing joints that have become loose will help to reduce the noise created by the old system. Once the motor has been cleaned and restored, the rest of the system will need to be cleaned as well. This includes sending metal parts

to rust removing companies that can restore the parts and contacting woodworking specialists that can recreate the old wooden parts such as the water wheels.

Our interview with construction manager, John, revealed that past projects have required parts to be sent in to be cleaned and that is was a feasible task to accomplish with limited room for error. However, some parts might be too rusted to be cleaned and would have to be custom ordered from a metal manufacturing company in order for the parts to be reproduced and reincorporated into the system. The system will require some alteration to ensure that the motor achieves a quiet operation. The current exhaust system of the motor is a simple metal pipe that opens out into the open air on the west side of the motor house.



Figure 29: Exposed Exhaust Pipe of Current Motor System

As the picture above shows, there is no currently existing muffling system attached to the end of this pipe. Incorporating a basic car muffler onto the end of this pipe will reduce noise emitted from the inside of the motor house and help to quiet the overall system. Lister Petter also stated that they provide muffler attachments for HA2 type models which demonstrated that a muffling system can also be available from the manufacturing company. The noise study showed that the sound of the system does not travel very far into the marsh area. Therefore, the system only requires small alterations to ensure that the operation is quiet enough to not affect the surrounding environment. Incorporating a muffler to the end of the exhaust pipe also provides an opportunity to install a filtering system to help reduce the diesel pollution from the end of the pipe, thus making the system more environmentally friendly.

6.4 Full Motor Replacement

Another option besides restoration would be replacement. Our replacement options consist of equivalent diesel replacements as well as environmental alternatives.

6.4.1 Methodology of Full Motor Replacement

In order to determine how feasible full motor replacement would be, our group researched various motor producers along with Lister Petter. This research involved looking for alternative diesel motors of the same capacity. Our group looked for costs, technical mechanics, reputation, expected lifespan, and maintainability for each motor. When more information was necessary, beyond that available online, our group contacted respective companies and organizations either by email or phone.

6.4.2 Results and Discussion of Full Motor Replacement

For future operation, several ways of restoring or replacing the Lister diesel motor are possible. Lister is a reputable and well established producer of diesel systems with a distributor, Data Power Incorporated, located in Yauco Puerto Rico. A currently produced equivalent to the HA2 is the TR2. The TR series offers three options, indicated by the number of cylinders in the machine: TR1, TR2, and TR3 varying in capacity and power from smallest, 1, to largest, 3. The TR2 provides 11-14.4 kw and 14.75-19.31 horse power at 1800 revolutions per minute starting at a base price of \$3780. This motor has two cylinders, is diesel fueled, air cooled, direct injected, and is hand or electric started (Lister Petter). This system would be able to replace the current system at Salinas Fortuna without effecting salt flat production.

Another option is to obtain a replacement motor from an alternative company to Lister. Two companies offering products similar to Lister's HA2 are Perkins Engine and the Carroll Stream Motor Company. Perkins offers the 403D-07 motor. This motor is Perkins' ultra-compact, lightweight off highway motor. This motor offers 20.5 horse power at 3600 revolutions per minute, has 3 cylinders, is liquid cooled, 12 volt electric started, and weighs 156 pounds. Perkins' local distributor, Rimco Cat in San Juan, provided pricing of the 403D-07 at \$2500. Carroll Stream offers the CS20V2, a 2 cylinder 4 stroke diesel motor. The company provides a 20 horse power motor at 3600 revolutions per minute. The motor is air cooled, electric started, weighs 130 pounds, and is offered through their online website for \$1,800.

Due to the simplicity of a diesel engine, all three options consist of very minimal maintenance. The only wear parts are the filters, air, fuel and oil. These parts all cost less than \$25 each with oil changes between 200 and 400 hours. The diagram below is a visual representation of the format for the replacement systems. The top sketch incorporates the electric

motor option which will operate one water wheel while the rest of the system remains on display. Figure 31 is the system restored with either a newer replacement motor operating the system or the old motor with an electric start option.

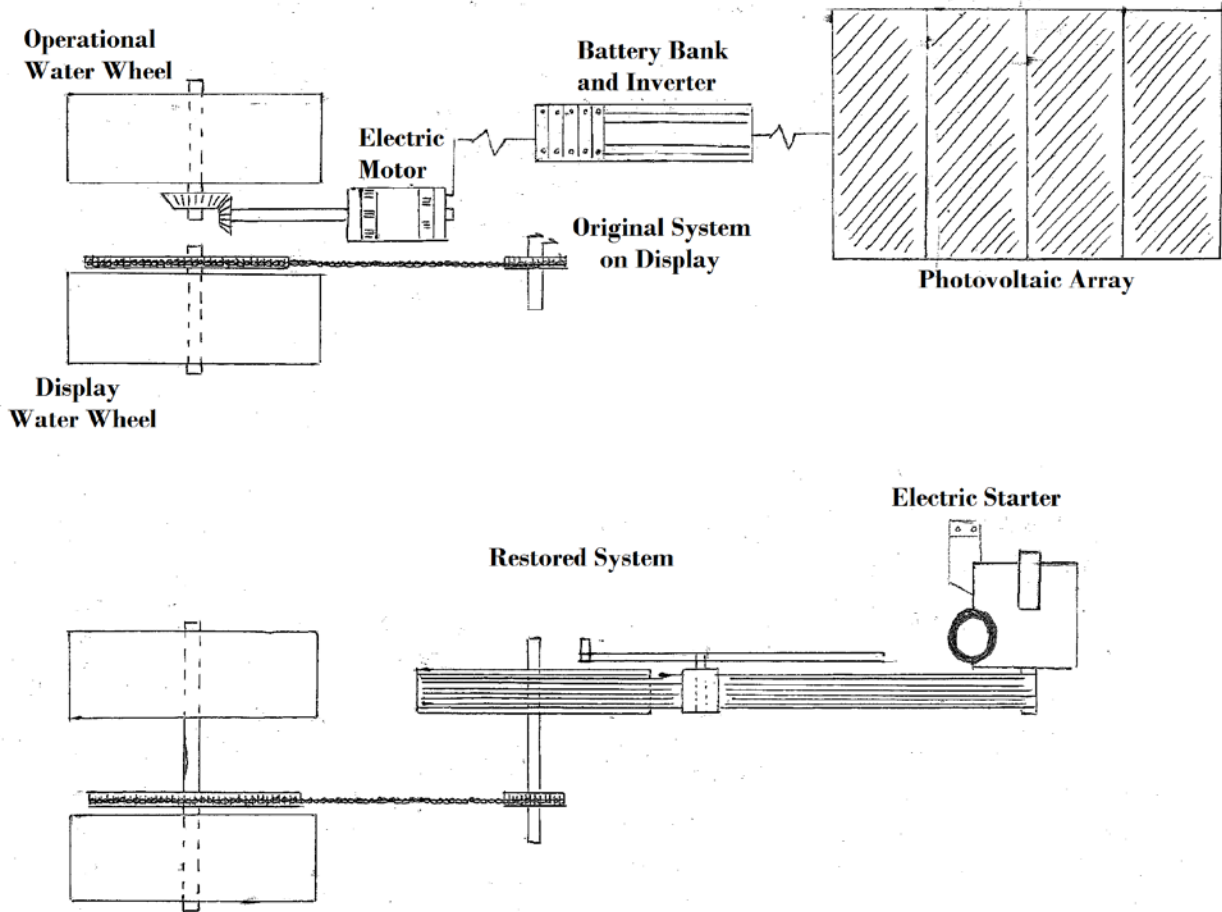

Figure 30: Full Motor Replacement Sketches

6.5 Environmental Alternatives

Both restored and replaced options can incorporate environmental alternatives to decrease their negative impact on the surrounding ecosystem.

6.5.1 Methodology of Environmental Alternatives

Our team looked at reducing other forms of pollution caused by the motor's diesel dependence. The current operating motor is fueled by diesel oil, a non-renewable resource that causes pollution of both land and air over time. In order to reduce the dependence on fossil fuels, and eliminate any potential sources of pollution, our group investigated various ways to maintain the old motor system with integrated environmentally friendly alternatives.

Our group researched current day practices for reducing diesel fuel emissions and ways to produce energy without the use of fossil fuels. Recommendations were based on replacing and or upgrading the diesel with either electrical options or with alternative renewable energies from wind, water, or solar resources. Any recommended alternatives were also evaluated for their practicality, ease of replacement, and their costs. A cost analysis was not conducted for these alternatives due to the fact that these are new technologies and determining the projected costs several years in the future was beyond the scope of this project. Our group looked at immediate implementation costs, however, the final recommendations were based on the impact each option had on the environment and how this benefited the operation of the water moving system.

6.5.2 Results and Discussion of Environmental Alternatives

6.5.2.1 Electric Starter

If the current motor continues to operate, the existing machinery may be outfitted with an electric starter that has a battery and recharge winding. This modification, offered by Realdiesel,

would cost between \$500 and \$1000. The recharge winding allows the starter to be powered by a battery that is recharged for the next use during motor operation. The system would remain functioning as is but would allow for the machine to be started and operated by almost anybody. This option would open the machinery up for easy intermittent use. With the push of a button the system could be powered up and shut down for demonstration or production. However, this option does not eliminate fossil fuel dependence and the system would still require diesel to maintain operation.

6.5.2.2 *Solar Power*

To allow for future site development, the most realistic and easily implemented option is a photovoltaic solar array. This would open the site up for modern technologies to be used in the visitor infrastructure of the site. Often there are governmental incentives or tax credits for integrating solar technologies. The best location for panels to be installed is on a southern facing roof, to best capture the path of the sun. To outfit a location with panels, the total electricity used on site and the time of available sunlight provide the wattage supply needed from the solar array. Without an accurate concept of the exact power requirements and future increases in demand at Salinas Fortuna, a large supply system cannot accurately be calculated. For some estimate figures, the average US home in 2011 used over 11000 kWh of electricity, at 940 kWh per month. At 940 kWh per month the estimated photovoltaic array cost to supply 100% of the needed power is approximately \$15000. Solar panels are sold based on the amount of storage space needed to hold the power which means that the estimate of \$15000 would be for one single photovoltaic array to support the house system. We don't expect the site to use as much power as a full size residence and believe the cost would be less than the estimate for a residence (Wholesale Solar).

6.5.2.3 Electric Replacement

With the integration of solar power at the site, the necessity of a fossil fuel machinery driver is negated. An electric motor could perform the same task as the diesel motor. Electric motors can achieve a much greater torque at slower operating speeds than an internal combustion engine making initial wheel motion easier and possibly eliminating the need for the mechanical advantage strap and gear system (Electric Motors Reference Center). A 22 horse power electric motor would do the job of the 22 horse power diesel however it would also be able to produce more power than necessary. An internal combustion engines horse power rating is based on its maximum achievable power. On the other hand an electric motor is rated by its consistent operational power. To obtain an estimate of the electric motor needed to replace the internal combustion engine, the rating of the fueled motor is divided by 2-2.5 to give the operational power rating of the equivalent electric motor. The 22hp diesel divided by 2-2.5 is 11-8.8 horse power. This means an electric motor as small as 10 horse power could be expected to operate the same system as the existing HA2 diesel (Marine, 2008).

6.5.2.4 Summary of Environmental Alternatives

However, incorporating a simple muffling system or full diesel replacement might not be enough to make the system environmentally friendly and sustainable. While there are many ways to reduce the noise and maintain the old system, replacing certain parts of the system will be necessary to increase the environmental benefits of operating the historical system. The most appropriate way to completely reduce the pollution of the motor is through replacing the motor with an electric motor. As discussed, there are motors currently available that can replace the current diesel motor, remove the fossil fuel dependence, and effectively operate the system. Removing fossil fuel dependence not only helps reduce demand for non-renewable resources but

also eliminates the harmful fumes that pour out of the end of the exhaust pipe and spill into the surrounding environment. Salinas Fortuna has no electricity on site and this system would therefore be dependent on alternative electrical energy generation options.

The most feasible option at this time is employing the use of solar energy. The south portion of the island is very dry, with more sun exposure than the northern side of the island. Installing solar panels on the roof of the motor house (or canopy) would provide Salinas Fortuna with the necessary power source for operation. Environmental impacts aside, solar panels would be a good source of education for visitors who can see this solar energy system and learn how it has been incorporated into the operation of Salinas Fortuna. A person viewing this system at Salinas Fortuna could potentially be inspired to reduce their own energy dependence and attempt to incorporate alternative energy options into their lifestyle. The additional benefit of a completely electric motor option also ties into the noise concerns of the old motor. An electric motor's operation would be much quieter than the current motor. Installing an electric motor would also eliminate the need for soundproofing or muffler options and would allow Fideicomiso to create an exhibit of the old system while completely reducing their concerns of noise and environmental pollutions into the surrounding ecosystem.

6.6 Motor Analysis

Our group wanted to form a recommendation as to whether the restoration or replacement of the motor on Salinas Fortuna would comply with Fideicomiso's least impact goal.

6.6.1 Methodology of Motor Analysis

In order to conclude whether restoring or replacing the motor was the best option, our group used a multi-attribute decision making process (Sullivan, Wicks, & Koelling, 2011). We chose to use this method due to the capability of accounting for multiple aspects with

individually assignable weighted preference. In this method, the aspects considered more crucial were given a higher weight than other, less critical, aspects. The end goal of the analysis was finite normalized worth quantities that represent the relative worth of the options compared to each other. The option with the highest worth rating was deemed the preferred decision. The steps involved in this method are as follows:

1. Determine project options
2. Determine attributes that contribute to the worth of the project
3. Determine the normalized weight of each attribute
4. Normalize all attributes ratings associated with the various options
5. Multiply each attribute's normalized rating by normalized weight
6. Sum the products of step five for each separate option
7. Compare the sums from step six and choose the highest worth as the optimum decision.

To determine the optimum project outcome, each motor option was clearly defined. Once the various available options were defined, the attributes that differed between these options was determined. It is important to note that attributes were characteristics shared by all options, but differed in either cost or quality.

Once all attributes that impact the worth of the project were known, they were weighted by importance relative to each other, which gave them a normalized weight. To attain the normalized weighting, a relative weight was assigned to each attribute and divided by the sum of all assigned attribute weight quantities. It could therefore be seen that the normalized weight represented the fraction share of total points (i.e., weight) assigned to all attributes.

Another value which must be normalized was the rating of each attribute within each option. It was important to understand and not confuse that the rating of an attribute was the metric used to depict how well an option satisfied a desired attribute while the weight of an attribute was how important each attribute was to the project outcome. Rating quantities were also normalized to allow for units of different ranges to be compared on a similar scale. The method that determined the normalized rating can be seen in Equation 1.

$$\text{Normalized Rating} = \frac{\text{Worst Possible Rating} - \text{Rating to be Normalized}}{\text{Worst Possible Rating} - \text{Best Possible Rating}}$$

Equation 1: Quantitative Normalized Rating

Qualitative normalized ratings were determined by assigning each option a quantitative relative rating, from one to n , n being the amount of possible values. Once all qualitative ratings were assigned quantitative ratings, Equation 2 can be used to determine their normalized rating.

$$\text{Rating} = \frac{\text{relative rank} - 1}{n - 1}$$

Equation 2: Qualitative Normalized Rating

By then multiplying each normalized rating by its corresponding normalized weight, the normalized worth for each option’s attributes were determined. These values are then totaled and the option with the highest worth was chosen.

6.6.2 Results and Discussion of Motor Analysis

1. Determine Project Options

As described in Section 6.1.6, a multi-attribute decision making process was used to determine the optimum choice between options for installing a new motor at Salinas Fortuna. The new motor would be the TR2, similar to the one currently installed and also manufactured by Lister Petter, is rated at 14.4 kW and 14.75-19.31 hp at 1800 rpm. The attributes that

contributed to the decision process were provided by Fideicomiso staff as motor cost, environmental friendliness, noise pollution, sound proofing costs, and maintenance costs.

2. Determine Attributes That Contribute to the Worth of the Project

To determine the environmentally friendliness of the system, a three point scale was used; the scale was poor, fair, or good. Poor implied that the motor polluted while good implied that there was some filtering system. Through the use of this scale, the new motor fell under the rank or “fair” due to its cleaner operation but could not achieve the highest rank due to its diesel reliance. The lack of filtration system and diesel dependence of the old motor classified it as “poor” based on our three point scale.

In identifying the noise of the motor, a three point scale was again used. Poor classified the motor as having almost no internal sound proofing while good suggested the motor had built in sound proofing to reduce operational noise. If the current motor creates too much noise there may be sound proofing costs for the system, which were also included.

The new motors create less noise and were rated as “good”. They are designed and manufactured with new technology to eliminate the noise that was created by older motors. Since the new motors do not create significant noise, we were able to determine that the new motor would require no sound proofing costs. On the other hand, the current motor would require a muffler and exhaust filter in order to reduce noise. From our interview with Lister Petter, we determined these two parts would cost about \$200 to sound proof the operation.

To verify the maintenance costs of each motor, our group contacted companies to determine the lifespan of each motor and the maintenance costs associated with each. Lister Petter explained that the maintenance of a new motor consisted of air filter, oil filter, and fuel filter replacement yearly. These parts cost about \$25 each. They also explained that every 250

hours the oil needs to be changed. This totaled to about \$100 in maintenance costs per year for a new motor.

To determine the maintenance costs associated with the current motor we spoke with Jose, the area coordinator of Salinas Fortuna. He explained that the motor is only run once a month and generally costs about \$60 per year to maintain. Our group assumed that, if the motor was run more often for educational purposes, the maintenance costs would just about double to \$120 per year. These are expected yearly costs; however, we wanted to keep in mind that if parts were to break the maintenance costs would increase.

However, this analysis did not include every situation for maintenance because there were some malfunctions and broken parts that our group was not able to predict. Maintenance costs were generalized and highly probable costs, such as spark plug replacement or lubrication, were considered. These attributes are summarized in Table 10.

Attribute	Current Motor	New Motor	Preference
Cost	\$0	\$3,780	Lower
Environmentally friendliness	Poor	Fair	Good
Noise	Poor	Good	Good
Sound proofing costs	\$200	0	Lower
Maintenance Costs/year	\$120	\$100	Lower

Table 10: Determine Attributes

3. Determine the normalized weight of each attribute

The relative weight of each of these attributes was also given by Fideicomiso and is displayed in Table 11. The normalized weights are determined by dividing each relative weight by the sum of all weighted quantities.

Attributes	Relative Weight	Normalized Weight
Motor Cost	9	0.19
Environmentally Friendliness	12	0.25
Noise Pollution	15	0.31
Sound Proofing Cost	7	0.15
Maintenance Costs (Annual)	5	0.10
Sum	48	1

Table 11: Normalize Weight of Attributes

4. Normalize all attributes ratings associated with the various options

It can be seen that there are three attribute ratings that are quantitative and two that are qualitative. The quantitative attribute ratings are motor cost, sound proofing cost, and maintenance cost (annual). By applying Equation 1, the normalized rating of each attribute can be determined.

$$\text{Normalized Rating} = \frac{\text{Worst Possible Rating} - \text{Rating to be Normalized}}{\text{Worst Possible Rating} - \text{Best Possible Rating}}$$

Equation 1: Quantitative Normalized Rating

Note that, by this equation, if there are only two options the only possible normalized ratings will be zero and one. The calculation of normalized rating can be seen in Table 12.

Attribute	Current Motor Normalized Rating	New Motor Normalized Rating
Cost	$(3,780-0)/(3,780-0) = 1$	$(3,780-3,780)/(3,780-0) = 0$
Sound proofing cost	$(200-200)/(200-0) = 0$	$(200-0)/(200-0) = 1$
Maintenance Costs/ Year	$(120-120)/(120-100) = 0$	$(120-100)/(120-100) = 1$

Table 12: Normalized Quantitative Ratings

The qualitative ratings are noise pollution and environmental friendliness. Their ratings are poor, fair, or good. Therefore, they will be given a sequential relative rating. Similar to the quantitative ratings, Equation 2 will be used to determine the normalized rating.

$$\text{Rating} = \frac{\text{relative rank} - 1}{n - 1}$$

Equation 2: Qualitative Normalized Rating

A summary of these normalized ratings can be seen in Table 13.

Attribute	Ratings	Relative Quantitative Rating	Normalized Rating
Environmentally friendly	Poor	1	0
	Fair	2	0.5
	Good	3	1
Noise	Poor	1	0
	Fair	2	0.5
	Good	3	1

Table 13: Normalized Qualitative Rating

5. Multiply each attribute's normalized rating by normalized weight

All weights and ratings are normalized, so the worth (or value) of each option's attributes can be determined by multiplying their corresponding weights and ratings. This calculation can be seen in the "worth" column of Table 14.

6. Sum the products of step four for associated with each option separately

Attribute	Weight	Current Motor		New Motor	
		Norm. Rating	Worth	Norm. Rating	Worth
Cost	0.19	1	0.19	0	0
Environmentally friendly	0.25	0	0	0.5	0.125
Noise	0.31	0	0	1	0.31
Sound proofing costs	0.15	0	0	1	0.15
Maintenance cost	0.10	0	0	1	0.10
Sum of score			0.19		0.69

Table 14: Analysis Results

7. Compare the sums from step six and choose the highest worth as optimum decision

It can be seen that the option of installing a new motor provides more worth than keeping the current motor. Therefore, installing the new motor is the preferred option.

6.6.3 Considerations

As seen in Table 15, the weight of the sound proofing costs as well as the maintenance costs are more lower than other attributes such as noise. The difference in price is also not large enough to create a great impact.

Attribute	Weight
Cost	9
Environmentally friendliness	12
Noise	15
Sound proofing costs	7
Maintenance Costs/year	5

Table 15: Attribute Weight

Another point to note is the assigned weight for the cost of the motor. The difference in cost of the new motor and the current motor is very large: however, the importance of this attribute is not significant enough to offset the weight of noise or the weight of environmental friendliness. The weight of each attribute has an effect on the outcome of the analysis. If the Fideicomiso were to decide to change the weighting of each attribute, the outcome may vary.

When identifying qualitative data, such as the environmental friendliness and noise of the motor, different scales can be used. Our team chose to use a three point scale: poor, fair, or good. This scale was chosen because the environmental friendliness does not greatly vary due to diesel dependence and the level of noise does not greatly vary, therefore there should not be a large range of choices.

When using this three point scale and converting qualitative ratings to a normalized rating, the motors are compared on a scale of zero to one, zero being poor, 0.5 being fair, and one being good. Keep in mind that if a different scale were chosen, the results would have slightly

changed. An example would be a four point scale: poor, fair, good, or excellent. This scale would result in a normalized rating of 0, 0.33, 0.66, 1.

Specifically in our situation, these variables will not affect the outcome of our motor analysis due to the size of the margin; the current motor had a score of 0.19 while the new motor had a score of 0.69. However, these considerations are still important to take note of had the weight, costs, or scales been chosen differently.

Chapter 7: Recommendations Summary and Limitations

To achieve Fideicomiso's main goal of preserving the historical significance of Las Salinas Fortuna salt flats with minimal negative impacts to the environment, our group completed our three main objectives: design of future visitor attractions, materials compilation, and restoring vs. replacing the salt production system. Through each objective we carefully considered ways to reduce any effects on the environment and through this our group was able to form recommendations.

Our design for future visitors included a motor house which employed the use of alternative energies and noise reducing options. Our group developed two main concepts that incorporated the current motor system to help maintain as much of the original structure of Salinas Fortuna as possible. One design involved slight modifications to be made to the current system but involved extensive redesign to the motor house in order to limit the amount of noise pollution from the motor's operation. This design could be used with either a cleaned original system using the same motor or through installing an electric start dependent on battery recharge during operation. Both designs would incorporate a muffler to the exhaust pipe and some type of filtration system in the piping to help reduce any harmful emissions from the diesel run motor. The other motor house design eliminated fossil fuel dependence and transformed the current motor house into an exhibit. This plan would involve cleaning the system but having the operation of the salt flats controlled by a hidden electric motor that would be connected directly to the water wheel system. This design would be powered by solar panels established on the roof of the motor house, thus providing clean power to the motor system operation.

To complement our design we compiled a database of least impact materials to be used throughout future site construction at Salinas Fortuna. The materials matrix presented alternative

options to Fideicomiso. Fideicomiso commonly uses the same materials at their sites during restoration to protect the historical significance of that site. The purpose of our material matrix was to help Fideicomiso incorporate environmentally safe materials into future designs without compromising the overall historical significance. Simple places to incorporate new materials are into internal structures of buildings for supports or in pavement options for parking areas. This matrix also provided Fideicomiso with the costs of materials to help the organization determine if it would be cost effective to implement other materials into their design or to simply use existing material types to create future structures.

To ensure the future operation of production machinery we provided Fideicomiso with alternatives to the current system which will reduce fossil fuel dependence and preserve the site's historical individuality. Through a motor analysis, our group determined that it would be more cost effective and environmentally friendly to replace the existing motor with a more up-to-date model. Replacement diesel options have internal filters incorporated into their designs which help to reduce harmful emissions as well as muffle operation noise, two concerns with the operation of the current diesel motor. Our group also researched electric alternatives to provide Fideicomiso with options that completely eliminate fossil fuel dependence. Electric motors can incorporate solar panel power systems which would create an environmentally friendly image for Fideicomiso onsite as well as help in reducing the impact that they will have on the surrounding ecosystem.

However, our project could not be successfully completed without overcoming project challenges. One major challenge was a lack of transportation. We did not have a car of our own to drive to site locations to obtain information. This limited the amount of sites we were able to travel to and perform case studies. However, this helped increase the effectiveness of our

remaining case study because we were able to provide more focus to the Cabo Rojo salt flats case study.

Our group was also limited by the current operational condition of the water moving system. As it is now, the motor only runs once a month for fifteen minutes to maintain lubrication, while the rest of the machinery does not function. Due to this our full restoration option is based on inadequate observations of the entire salt production system. This could not be overcome because of the inability to see long term operation. Ultimately, this limitation impacted our projection for maintenance costs of the existing diesel motor. We did not have a basis for information on the machine's requirements for extended operation or how reliable the system would be in full operation. Fideicomiso plans to return the system to full operation in order to create enough salt for demonstration, thus requiring Fideicomiso to operate the system at full power for an increased duration of time to determine if the current motor would be able to operate without breaking down. Despite the challenges throughout the development of our project, our group created multifaceted recommendations to provide Fideicomiso with flexibility in their future site design. Our group hopes to see Salinas Fortuna restored to operation through the implementation of a least impact salt production system. In the future, visitors will be able to learn from seeing the salt production system in operation as well as become involved in the natural environment of the salt flats. Salinas Fortuna is a unique location that provides people of all ages with an opportunity to learn about an industry that plays an important role all over the world.

References

- Berg, B., & Lune, H. (2012). *Qualitative Research Methods for the Social Sciences* (C. Campanella Ed.). Pearson: Karen Hanson.
- Bontempi, E. (2012). *Effective Strategies in Museum Distance Education*. Paper presented at the Information Science & IT Education.
- DasSarma, S., & DasSarma, P. (2012). Halophiles. *eLS*, (Microbiology). Retrieved April 9, 2013, from <http://halo.umbi.umd.edu/~dassarma/halophiles.pdf>
- El Yunque National Forest. (2009). *Interpretive and Conservation Master Plan*. Retrieved April 9, 2013, from https://fs.usda.gov/Internet/FSE_DOCUMENTS/fsbdev3_042752.pdf.
- Environmental Protection Agency. (2002). *Pollution Prevention Act of 1990*. United States Senate: Retrieved April 5, 2013, from <http://www.epa.gov/p2/pubs/basic.htm>.
- Environmental Protection Agency. (2012). Recycling Basics. Retrieved April 10, 2013, from <http://www.epa.gov/recycle/recycle.html>
- Environmental Protection Agency. (2013). Heat Island Impacts. Retrieved April 9, 2013, from <http://www.epa.gov/hiri/impacts/index.htm>
- Fideicomiso. (2013a). Natural Protected Areas. Retrieved May 1, 2013, from <http://www.fideicomiso.org/natural-areas/>
- Fideicomiso. (2013b). The Trust (CTPR). Retrieved May 1, 2013, from <http://www.fideicomiso.org/about-the-trust-ctpr/>
- Fideicomiso de Conservacion. (2013a). Conservation Trust of Puerto Rico. Retrieved March 28, 2013, from <http://www.fideicomiso.org/home.html>
- Fideicomiso de Conservacion. (2013b). La Parguera Nature Reserve (Eastern Segment).
- Google. (2013). Google Maps.
- Gwenn. (2011). Salt Flats & Wildlife Refuge in Cabo Rojo. Retrieved January 19, 2013, from <http://www.puertoricodaytrips.com/cabo-rojo-salt-flats/>
- Halverson, T. (2007). Active Learning Techniques. Retrieved April 4, 2013, from <http://ctl.byu.edu/teaching-tips/active-learning-techniques>
- Hansen, C. H. Fundamentals of Acoustics. Retrieved February 19, 2013, from http://www.who.int/occupational_health/publications/noise1.pdf
- Hub, S. L. (2013). Biodegradability. Retrieved April 15, 2013, from <http://www.sciencelearn.org.nz/Contexts/Enviro-imprints/Science-Ideas-and-Concepts/Biodegradability>
- Kite Aerial Photography. (2010). Pass the Salt Please. Retrieved April 3, 2013, from <http://arch.ced.berkeley.edu/kap/gallery/gal198.html>
- Lebrón Rivera, R. (2011). Las Salinas en Puerto Rico. *Notes for a history of the salt industry*.
- Lent, T. (2007). Low Emitting Materials Technical Brief (2.2 ed.).
- Lister CS Diesel Engine Parts. Retrieved March 20, 2013, from <http://www.realdiesels.co.uk/listerparts2.html>
- Maistry, P. (2007). Rapidly Renewable Materials (pp. 6).
- Meisel, A. (2010). *LEED Materials : A Resource Guide to Green Building*. New York, NY, USA: Princeton Architectural Press.
- Minns, M. (2008). Recycled, Recyclable, Green: What Does it All Mean? Retrieved April 9, 2013, from <http://www.hahnloeser.com/references/859.pdf>

- Missouri Department of Natural Resources. (2001). *Energy Producing Systems: Fossil Fuels*. Missouri: Retrieved April 3, 2013 from <http://www.dnr.mo.gov/education/energy/fossilfuelpower.pdf>.
- Mortar Net. (2009). Assuring Water Resistance of Masonry Construction. Retrieved February 15, 2013, from <http://ronblank.com/courses/mor04a/mor04a.pdf>
- Méndez-Gallardo, V. Puerto Rico: SOCIEDAD ORNITOLÓGICA PUERTORRIQUEÑA, INC
- Nesting shorebirds protected at the Cabo Rojo Salt Flats, Puerto Rico. Retrieved from Bird Life International website: Retrieved March 15, 2013 from <http://www.birdlife.org/community/2012/07/nesting-shorebirds-protected-cabo-rojo-salt-flats-puerto-rico/>.
- Nice, K. (19 February 2001). How Mufflers Work. *How Stuff Works Inc*. Retrieved March 23, 2013 from <http://www.howstuffworks.com/muffler.htm>
- Oberle, M. W. *Puerto Rico's Birds in Photographs*.
- Paulson, D. (1999). Techniques for Active Learning. *Active Learning for the College Classroom*. Retrieved April 4, 2013, from <http://www.calstatela.edu/dept/chem/chem2/Active/>
- Singh, P. (2000). Museum and Education (Vol. 47, pp. 13). Bhubaneswar: Orissa State Museum.
- Sullivan, W., Wicks, E., & Koelling, P. (2011). *Engineering Economy* (15th ed.).
- Tetreault, Z. S. a. C. E., Molinski, C. A. S. a. B. I. O., Breindel, J. T. S. a. M. E., Blauvelt, A. L. S. a. E. V., Golding, D. F. a. I. D., & Zeugner, J. F. F. a. H. U. (2008). *The Effects of non-natural sounds on visitor park experiences in Puerto Rico*. Worcester, MA U6 - ctx_ver=Z39.88-2004&ctx_enc=info:ofi/enc:UTF-8&rft_id=info:sid/summon.serialssolutions.com&rft_val_fmt=info:ofi/fmt:kev:mtx:book&rft.genre=book&rft.title=The+Effects+of+non-natural+sounds+on+visitor+park+experiences+in+Puerto+Rico&rft.au=Tetreault,+Zachary+Student+author+--+CE&rft.au=Molinski,+Christina+A.+Student+author+--+BIO&rft.au=Breindel,+Jay+T.+Student+author+--+ME&rft.au=Blauvelt,+Ashley+L.+Student+author+--+EV&rft.series=Urban+and+Environmental+Planning&rft.date=2008-01-01&rft.pub=Worcester+Polytechnic+Institute&rft.externalDocID=284174 U7 - eBook U8 - FETCH-wpi_catalog_2841741: Worcester Polytechnic Institute.
- U.S. Fish and Wildlife Refuge. (2013). *Cabo Rojo National Wildlife Refuge*. U.S. Fish and Wildlife Refuge Retrieved March 19, 2013 from <http://www.fws.gov/refuges/profiles/index.cfm?id=41521>.
- U.S. Fish and Wildlife Service. (2012). *Caribbean Endangered and Threatened Animals*. Retrieved April 1, 2013 from <http://www.fws.gov/caribbean/es/Endangered-Animals.html>.
- United States Department of Agriculture. (2006). *El Portal Rain Forest Center, Interpretive Site Guide*: Caribbean National Forest.
- United States Fish and Wildlife Service. (2013). Digest of Federal Resource Laws of Interest to the U.S. Fish and Wildlife Service.
- United States Green Building Council. (2011). *Green Building Design & Construction LED Reference Guide for Retail: New Construction* (2009 ed.). Washington D.C.
- University of New South Wales. (2006). *Electric Motors and Generators*. Retrieved April 2, 2013

Weaver, P., & Schwagerl, J. *U.S. Fish and Wildlife Service Refuges And Other Nearby Reserves In Southwestern Puerto Rico* Retrieved March 27, 2013 from http://www.fs.fed.us/global/iitf/pubs/GTR_IITF40.pdf.

Weaver, P., & Schwagerl, J. (2008). Secondary Forest Succession and Tree Planting at the Laguna Cartagena and Cabo Rojo. *37*, 598-603.

Wholesale Solar. Solar Panels. Retrieved April 7, 2013, from www.wholesalesolar.com

Appendices

A. List of Birds

B. FAMILY	SCIENTIFIC NAME	COMMON SPANISH	COMMON ENGLISH	1983	2006	2010	ORIGIN	STATUS
		NAME	NAME					
Accipitridae	<i>Buteo jamaicensis</i>	Guaraguao Colirrojo	Red-tailed Hawk		X	X	R	
Accipitridae	<i>Pandion haliaetus</i>	Aguila de Mar	Osprey	X		X	M	F-SOC
Alcedinidae	<i>Megaceryle alcyon</i>	Martín Pescador (Norteño)	Belted Kingfisher	X			M	
Anatidae	<i>Anas bahamensis</i>	Pato Quijada Colorada	White-cheeked Pintail		X		R	CL, CV
Anatidae	<i>Anas discors</i>	Pato Zarcel	Blue-winged Teal		X		M	
Ardeidae	<i>Ardea alba</i>	Garza Real	Great Egret	X		X	R	
Ardeidae	<i>Ardea herodias</i>	Garzón Cenizo	Great Blue Heron	X	X		M	
Ardeidae	<i>Bubulcus ibis</i>	Garza Ganadera	Cattle Egret	X			R	
Ardeidae	<i>Butorides striata</i>	Martinete Verde	Green-backed Heron		X		R	
Ardeidae	<i>Butorides virescens</i>	Martinete	Green Heron	X			R	
Ardeidae	<i>Egretta caerulea</i>	Garza Azul	Little Blue Heron		X		R	
Ardeidae	<i>Egretta thula</i>	Garza Blanca	Snowy Egret		X		R	
Ardeidae	<i>Egretta tricolor</i>	Garza Pechiblanca	Tricolored Heron	X			R	

B. FAMILY	SCIENTIFIC NAME	COMMON SPANISH	COMMON ENGLISH	1983	2006	2010	ORIGIN	STATUS
		NAME	NAME					
Ardeidae	<i>Ixobrychus exilis</i>	Martinetito	Least Bittern	X			R	
Ardeidae	<i>Nyctanassa violacea bancrofti</i>	Yaboa Común	Yellow-crowned Night Heron	X			R	
Caprimulgidae	<i>Caprimulgus noctitherus</i>	Guabairo Pequeño de PR	Puerto Rican Nightjar	X			E	CL, FE
Cathartidae	<i>Cathartes aura</i>	Aura Tiñosa	Turkey Vulture	X	X	X	I	
Charadriidae	<i>Charadrius semipalmatus</i>	Chorlito Acollarado	Semipalmated Plover	X	X		M	
Charadriidae	<i>Charadrius vociferus</i>	Chorlito Sabanero	Killdeer	X			R	
Charadriidae	<i>Charadrius wilsonia</i>	Chorlito Marítimo	Wilson's Plover	X	X		R	CL
Charadriidae	<i>Pluvialis squatarola</i>	Chorlito Cabezón	Black-bellied Plover	X			M	
Coerebidae	<i>Coereba flaveola</i>	Reinita común	Bananaquit	X	X	X	R	
Columbidae	<i>Columbina passerina</i>	Rolita	Common Ground Dove	X	X	X	R	
Columbidae	<i>Zenaida asiatica</i>	Tórtola Aliblanca	White-winged Dove	X	X		R	
Columbidae	<i>Zenaida aurita</i>	Tórtola Cardosanterá	Zenaida Dove	X	X	X	R	
Columbidae	<i>Zenaida macroura macroura</i>	Tórtola Rabilarga o Rabiche	Mourning Dove	X	X		R	
Cuculidae	<i>Coccyzus minor</i>	Pájaro bobo menor	Mangrove Cuckoo	X	X	X	R	
Cuculidae	<i>Crotophaga ani</i>	Judío / Garrapatero	Smooth-billed Ani	X	X	X	R	
Emberizidae	<i>Ammodramus savannarum</i>	Gorrión Chicharra	Grasshopper Sparrow	X			R	DD, UV
Emberizidae	<i>Loxigilla portoricensis</i>	Comeñame	Puerto Rican Bullfinch		X	X	E	

B. FAMILY	SCIENTIFIC NAME	COMMON SPANISH	COMMON ENGLISH	1983	2006	2010	ORIGIN	STATUS
		NAME	NAME					
Emberizidae	<i>Tiaris bicolor omissus</i>	Gorrión Negro	Black-faced Grassquit	X	X	X	R	
Estrildidae	<i>Estrilda melpada</i>	Veterano	Orange-cheeked Waxbill	X			I	
Estrildidae	<i>Lonchura cucullata</i>	Diablito / Pandillero	Bronze Mannikin			X	I	
Estrildidae	<i>Lonchura malabarica</i>	Gorrión Picoplata	Indian/Warbling Silverbill	X			I	
Falconidae	<i>Falco columbarius</i>	Falcón Migratorio	Merlin	X			M	
Falconidae	<i>Falco sparverius</i>	Falcón Común	American Kestrel	X		X	R	
Fregatidae	<i>Fregata magnificens</i>	Tijerilla / Fragata Magnífica	Magnificent Frigatebird	X	X		R	
Hirundinidae	<i>Hirundo rustica</i>	Golondrina Horquillada	Barn Swallow	X			M	
Hirundinidae	<i>Petrochelidon fulva</i>	Golondrina de Cuevas	Cave Swallow	X			R	
Hirundinidae	<i>Riparia riparia</i>	Golondrina Parda	Bank Swallow	X			M	
Icteridae	<i>Agelaius xanthomus</i>	Mariquita de PR	Yellow-shouldered Blackbird	X	X		E	CL, CE, FE
Icteridae	<i>Icterus galbula</i>	Calandria del Norte	Baltimore Oriole	X			M	
Icteridae	<i>Icterus icterus</i>	Turpial	Troupial	X	X	X	I	
Icteridae	<i>Molothris bonariensis</i>	Tordo Lustroso	Shiny Cowbird	X	X		R	
Icteridae	<i>Quiscalus niger</i>	Chango / Mozambique	Greater Antillean Grackle	X	X	X	R	
Mimidae	<i>Margarops fuscatus</i>	Zorzal Pardo	Pearly-eyed Thrasher	X	X	X	R	

B. FAMILY	SCIENTIFIC NAME	COMMON SPANISH	COMMON ENGLISH	1983	2006	2010	ORIGIN	STATUS
		NAME	NAME					
Mimidae	<i>Mimus polyglottos</i>	Ruiseñor	Northern Mockingbird	X	X	X	R	
Muscicapidae	<i>Turdus plumbeus</i>	Zorzal de Patas Coloradas	Reg-legged thrush	X		X	R	
Parulidae	<i>Dendroica adelaidae</i>	Reinita Mariposera	Adelaide's Warbler	X	X		E	
Parulidae	<i>Dendroica coronata coronata</i>	Reinita Coronada	Yellow-rumped Warbler	X			M	
Parulidae	<i>Dendroica discolor</i>	Reinita Galana	Prairie Warbler	X	X	X	M	
Parulidae	<i>Dendroica palmarum</i>	Reinita Palmera	Palm Warbler	X			M	
Parulidae	<i>Dendroica petechia</i>	Canario de Mangle	American Yellow Warbler	X	X		R	CL
Parulidae	<i>Dendroica tigrina</i>	Reinita Tigre	Cape May Warbler	X			M	
Parulidae	<i>Geothlypis trichas trichas</i>	Reinita Picatierra	Common Yellowthroat	X			M	
Parulidae	<i>Mniotilta varia</i>	Reinita Trepadora	Black-and-White Warbler	X			M	
Parulidae	<i>Parula americana</i>	Reinita Pechidorada	Northern Parula	X			M	
Parulidae	<i>Protonotaria citrea</i>	Reinita Anaranjada	Prothonotary Warbler	X			M	
Parulidae	<i>Seiurus motacilla</i>	Pizpita de Río	Louisiana Waterthrush	X			M	
Parulidae	<i>Seiurus noveboracensis</i>	Pizpita de mangle	Northern Waterthrush	X	X		M	
Parulidae	<i>Setophaga ruticilla</i>	Candelita	American Redstart	X			M	
Pelecanidae	<i>Pelecanus occidentalis</i>	Pelícano pardo	Brown Pelican	X	X		R	CL, CE
Picidae	<i>Melanerpes portricensis</i>	Pájaro Carpintero de PR	Puerto Rican Woodpecker			X	E	

B. FAMILY	SCIENTIFIC NAME	COMMON SPANISH	COMMON ENGLISH	1983	2006	2010	ORIGIN	STATUS
		NAME	NAME					
Rallidae	<i>Gallinula chloropus</i>	Gallareta Común	Common Moorhen	X			R	
Rallidae	<i>Rallus limicola</i>	Rascón limícola	Virginia Rail	SOPI (2002)			A	
Rallidae	<i>Rallus longirostris</i>	Pollo de mangle	Clapper Rail	X			R	
Recurvirostridae	<i>Himantopus mexicanus</i>	Viuda	Black-necked Stilt	X	X		R	
Scolopacidae	<i>Actitis macularius</i>	Playero Coleador	Spotted Sandpiper	X	X		M	
Scolopacidae	<i>Arenaria interpres</i>	Playero Turco	Ruddy Turnstone	X	X		M	
Scolopacidae	<i>Calidris alba</i>	Playero Arenero	Sanderling	X			M	
Scolopacidae	<i>Calidris himantopus</i>	Playero Patilargo	Stilt Sandpiper	X			M	
Scolopacidae	<i>Calidris mauri</i>	Playero Occidental	Western Sandpiper	X			M	
Scolopacidae	<i>Calidris minutilla</i>	Playero Menudillo	Least Sandpiper	X			M	
Scolopacidae	<i>Calidris pusilla</i>	Playero Gracioso	Semipalmated Sandpiper	X	X		M	
Scolopacidae	<i>Catoptrophorus semipalmatus</i>	Playero Aliblanco	Willet	X			M	
Scolopacidae	<i>Limnodromus griseus</i>	Chorlo Picocorto	Short-billed Dowitcher	X	X		M	
Scolopacidae	<i>Tringa flavipes</i>	Playero Guineilla Pequeña	Lesser Yellowlegs	X	X		M	
Scolopacidae	<i>Tringa melanoleuca</i>	Playero Guineilla Grande	Greater Yellowlegs	X			M	
Scolopacidae	<i>Tringa solitaria</i>	Playero Solitario	Solitary Sandpiper	X			M	
Thraupidae	<i>Euphonia musica sclateri</i>	Jilguero	Antillean Euphonia			X	R	

B. FAMILY	SCIENTIFIC NAME	COMMON SPANISH	COMMON ENGLISH	1983	2006	2010	ORIGIN	STATUS
		NAME	NAME					
Thraupidae	<i>Spindalis portoricensis</i>	Reina Mora	Puerto Rican Spindalis		X	X	E	
Todidae	<i>Todus mexicanus</i>	San Pedrito de PR	Puerto Rican Tody	X	X	X	E	
Trochilidae	<i>Anthracothorax dominicus</i>	Zumbador Dorado	Antillean Mango	X			R	
Trochilidae	<i>Chlorostilbon maugaeus</i>	Zumbadorcito de PR	Puerto Rican Emerald			X	E	
Tyrannidae	<i>Contopus latirostris blancoi</i>	Bobito Antillano Menor	Lesser Antillean Pewee			X	R	
Tyrannidae	<i>Elaenia martinica riisii</i>	Jui blanco	Caribbean Elaenia			X	R	
Tyrannidae	<i>Myiarchus antillarum</i>	Juí de Puerto Rico	Puerto Rican Flycatcher	X	X		E	
Tyrannidae	<i>Tyrannus dominicensis</i>	Pitirre gris	Gray Kingbird	X		X	R	
Vireonidae	<i>Vireo latimeri</i>	Bien-te-veo	Puerto Rican vireo		X	X	E	UV

(Fideicomiso de Conservacion, 2013b)

B. Motor

Lister Motor of Salinas Fortuna Salt Flats	
Model	HA2
Cylinders	2
Capacity (cc)	1853
Bore & Stroke	4 X 4 ½
HP @ RPM (max)	22 @ 1800
Cooling	Air
Weight (lb)	620
Fuel	Diesel

("Lister CS Diesel Engine Parts,")

C. Interview: U.S. Fish and Wildlife Contact and Cabo Rojo Salt Flats Manager,

Oscar Diaz

We are students from Worcester Polytechnic Institute, a university in Massachusetts, U.S.A. We are currently conducting a project with the Fideicomiso de Conservacion (San Juan, PR). We are gathering information about preserving the environment in La Parguera Nature Reserve in Lajas. Our group is investigating the feasibility of restoring the salt flats historical significance without harming the surrounding ecosystem. We were wondering if we could have a few minutes of your time. Participation in the research is voluntary. Participants may end their participation at any time. Participants need not answer every question in an interview or survey.

1. Are you a non-profit organization?
2. If so, what is your primary source of funding?
3. Are the salt flats currently being used for salt production or solely for demonstration?
4. What is/was the general process for salt production on these salt flats?
5. What kind of water moving system is being used on the salt flats?
6. On a yearly basis how much does the water moving system cost to maintain?
7. Does the water moving system create a significant amount of pollution and noise?
8. If so, has the pollution and noise of the moving system impacted surrounding wild life?
9. Has your reserve had to comply with keeping pollution, both noise and environmental, within OSHA and/or LEED standards?
10. If so, what has the reserve done to regulate these noise and pollution levels?
11. Which species, both plant and animal, are you actively working to protect?
12. What typical protective measures are enforced when opening general preservation sites up to visitors and human interactions?
13. What controls must be considered when developing a human-environment interface?
14. What environmental considerations were taken into account when continuing the operation of the salt flats?
15. What are the most popular attractions in the Cabo Rojo reserve?
16. What effects do visitors have on the environment?
17. What systems were implemented to control visitor traffic and visitor interactions with the preserved environment?
18. What materials are currently in use for the construction of tourist walkways and visitation centers? How have these materials helped to protect the environment and save energy?

D. Minutes from Interview with U.S. Fish and Wildlife Contact and Cabo Rojo Salt Flats Manager, Oscar Diaz

Title: refuge manager for the Cabo Rojo salt flats and one other refuge on the island.

1. They are a federal government organization so they are non profit
2. Funds come from Congress. They must obey congress law and the National Wildlife Refuge Act.
 - The Cabo Rojo refuge has 6 uses:
 - Hunting
 - Fishing
 - Environmental education
 - Environmental interpretation
 - Environmental photography
 - Environmental observations
 - They allow other uses but must first pass regulations to make sure appropriate for wildlife refuge.
 - When they bought the land salt production was already there and in use. They determine that salt harvesting was compatible for the refuge. Salt flats have been there for more than 500 years. Management of water levels and salinity creates unique ecosystem.
 - Salinas was abandoned and the system was manipulated. There needed to be human interaction needs to maintain levels and salinity concentration.
3. Same process as 500 years ago. The shallow lagoons are isolated from the sea. They opened a canal to connect the sea water and fill the lagoons, once filled they close the gates. The lagoons then become evaporating ponds and salinity starts. When they are of high salinity the water is moved into crystalizing bins made of wood. Allow to precipitate and collect there rather than in the ponds due to environmental considerations.
4. In the past used windmills to move water from lagoon to crystallizer, today use motor.
5. Jeffery is the owner of the enterprise profiting from the salt production (Empresas Padilla Incorporated). Oscar works with him under a special use permit to negotiate maintenance. (How will he innovate area and what he needs.)
 - During migratory season birds come and production must be stopped. The birds need the water and so if a pond starts to evaporate it must be refilled. Jeffery is using public land for private benefit so must comply with this.
6. Heavy rain might bring a little bit of oil from roads and cause pollution but issue is minimal.
7. NA
8. Comply with OSHA. The noise of the pump is not loud and is not used continuously so is not a real issue.
 - Motor – 10 hp diesel, uses long hoses to pump water
9. Use Federal Regulations. This accounts for regulations such as air craft, which is prohibited from flying below 500 ft.

10. Unique species found on the refuge so use strict laws to prevent people from impacting environment.
11. Use environmental education in visitor center to prevent impacts. They also implement lines to identify sensitive areas.
 - The trails are located in areas that will create the least impacts.
 - Cars and bikes on one road while walkers on a trail.
 - People respect and they enforce laws.
12. NA
13. Minimal environmental issues but if there was a problem they would act upon it
14. NA
15. NA
16. NA
17. They are mandated to use at least 10% recycled material. Not easy to comply with in PR.

When creating the bike trail Oscar used plastic wood. It was expensive because it was only sold in one place on the island. He is trying to use the same material for the benches and posts on the refuge.

He has used other material such as aluminum, plastic, and PVC but he avoids it.

Next time we visit the site Oscar would like to meet with whole group.

E. Minutes from Interview with Cabo Rojo Salt Refuge Employee (tour guide)

3/28/2013

- The workers don't dig to the bottom of the salt flats, during harvesting, in order to cause less damage
- There is an unseen ecosystem of bacteria that lives at the bottom of the salt ponds which prevents the workers from digging all the way through.
- Soil when peeled away (around the salt flats) revealed layers of sediment soil. Each layer had a different type of bacteria to it, bacteria that needed oxygen was close to the surface, bacteria that lived without oxygen was at the bottom. This gave the soil its layers and colors.
- During the migratory season, the Cabo Rojo refuge leaves some ponds for the birds to use and avoids interacting with those ponds to give birds space.
- Sell to: Companies that create water softeners and to farms (fatten animals or give to cows to produce more milk)
- Bird watching tower made of wood, lasted 10 years with only small refurbishments
- Plastic wood used to make benches but cracks and warps in heat. She does not recommend its use.
- In order to fill the lagoons, they use gates to allow water to flow in. When it turns red, water is moved into evaporation pond for about 3 months then salt is scraped out.
- Cabo Rojo refuge has been established for many years which has allowed for the surrounding ecosystem to get used to the reserve and the human interactions, disturbing wildlife is no longer a concern so long as they continue to do as they have always done.

F. Minutes from Interview with Cabo Rojo Refuge Employee (salt production) 4/19/13

- Water travels from the ocean in channels to the ponds
- Needs one month for the sun to evaporate the water and usually receive about 1.5 inches of salt
- They use the pump to extract the water and the trucks are then used to collect salt
- The pink color indicates readiness to extract water and the color is from the bacteria and iodine
- Afterwards the pond is cleaned using the pump and trucks. Ground is leveled out and the bottom is left smoothed rather than scraped in order to not harm the environment
- Pump runs every 50 days
- Water fills pond, after 30 days the color changes and extract water, move salt, on 50th day clean the ponds
- Manmade channels move the excess water back to the lagoon using man made channels, creating a circle around the salt flats
- Total of 3 pumps, two smaller ones used to extract water, and one larger one used to clean the ponds
- Windmills used to be the energy for the water moving system (had five of them)
- Salt is used to clean, for water filters, and pharmacy use. Hotel across the road also uses it for salt water hot tub and facial spa techniques
- Regulations: activity must be contained in area, no room to expand. The bird area can only have walking or biking trails.
- The salt piles are continuously turned over allowing sediments to settle and top of the pile becomes more clean
- Salt is packed in 50 or 100 lb bags. The 50 lb bag is five dollars
- Sold per ton
- They use general types of wood, cheap and easy to use, continuously changing the wood as it deteriorates
- 12 ponds
- Named “fraternity” ponds
- Hours of operation 7-4, during the summer 5-2

G. Interview: Fideicomiso Engineer, John

We are students from Worcester Polytechnic Institute, a university in Massachusetts, U.S.A. We are currently conducting a project with the Fideicomiso de Conservacion (San Juan, PR). We are gathering information about preserving the environment in La Parguera Nature Reserve in Lajas. Our group is investigating the feasibility of restoring the salt flats historical significance without harming the surrounding ecosystem. We were wondering if we could have a few minutes of your time. Participation in the research is voluntary. Participants may end their participation at any time. Participants need not answer every question in an interview or survey.

1. What projects have you completed for Fideicomiso?
2. What have they entailed?
3. From a design perspective what are your main considerations when buildings structures?
4. What materials are commonly used for outdoor structures?
5. Do you use specific material when designing structures in salt water?
6. Do you have any suggestions on how to restore building structures?
7. Do you use any specific techniques when restoring versus replacing structures?
8. Are you familiar with La Salinas Fortuna salt flats?
9. Do you have any recommendations on how to restore the water moving system house which is submerged in water?
10. Have you created boardwalk systems before?
11. If so, what are the considerations taken into account when creating these?
12. Have you created structures in the vicinity of bird sanctuaries?
13. If so, was there a distance that needed to be maintained?

H. Minutes from Interview with Fideicomiso Engineer, John

1. Construction manager, focuses on restoration and preservation
2. Last project was in Cabo Rojo, all done by hand
 - Boardwalk (20 inches high, 600 feet long)
 - Took 2 and a half weeks with 5 workers
 - Had to be careful of birds and mangroves
 - Supported by wood 4 by 4, soft area wood went down 4 feet, not soft only went down 2 feet
3. Follow national historic standards of preservation
4. Try to use same materials so don't change historic value.
 - If wood, seal it
 - He has used concrete before but mostly use wood and steel which can be reused and recycled
5. NA
6. He suggests we clean up and refinish metal in Salinas
7. NA
8. Yes
9. He will be restoring water wheel in ponce, it is made up of 3 types of wood, one being teak.
 - Suggests we still use wood for our wheel
 - Seal wood with Seca 32
 - Foundation is concrete
 - They have tried poly-pavement before, doesn't work well here because not dry enough
10. NA
11. NA
12. Every day!
13. Create specific controls, need to work around them
 - Clean every day in order to prevent damage (inventory of materials)
 - Work without use of machinery, all by hand
 - Specific paths established to get around site, can't leave the paths for any reason. Don't want to harm/alter the environment
 - Follow Lead basics, view guidelines online
14. Do work with them very often
15. This does limit them but have learned to work with them
 - Others find it hard to work with them due to rules followed
 - Do it right the first time

Conversational Notes

- He can give us information on previous projects
- Keep simple! Minimalistic.
- Will be hard to change to solar but good idea, need to check with manufacturer. Put starter on it.

I. Interview: Jose (Area Coordinator)

We are students from Worcester Polytechnic Institute, a university in Massachusetts, U.S.A. We are currently conducting a project with the Fideicomiso de Conservacion (San Juan, PR). We are gathering information about the current water moving system in La Salinas Fortunas salt flats in Lajas. The motor is a 22 HP 1800 RPM Diesel motor. We were wondering if we could have a few minutes of your time? Participation in the research is voluntary. Participants may end their participation at any time. Participants need not answer every question in an interview or survey.

1. How do you operate the water moving system?
2. How often is the motor in operation?
3. What parts have you replaced and what maintenance have you performed?
4. What were the costs associated with part replacements and maintenance?
5. What have been your difficulties while maintaining the water moving system?
6. What are key signs that a water moving system is not running properly?
7. What is done with the disposal of service and maintenance associated products?(Grease, etc)
8. Does the water moving system tend to create noise during operation? If so, how loud is the system on a scale of 1 to 10, 10 being the loudest.
9. If so, how would you recommend reducing operational noises?
10. What suggestions would you have for improving the motor operation and housing?

J. Minutes from Interview with Jose (Area Coordinator) 3/28

1. Crank but could use an electric starter
2. Twice a month, 10-15 minutes
3. Maintenance on the injection system and oil filter. Both were cleaned about a year and half ago
4. Maintenance about \$60, things such as paint and cleaning
5. Biggest issue is rats getting into the system. Another issue is that when the diesel runs out the system gets air into it and then needs to be restarted. This involves cleaning the injector and flushing the lines.
6. NA
7. During the rainy season water and oil mix runs out into the canal.
 - This could lead to a maintenance cost of oil disposal.
 - Needs a filtration system.
 - Structure of the house allows water to get in
 - They tried a small basement sub pump which didn't work.
 - Jose recommends we clean the area and start new system
8. NA
9. Noises come from looseness of parts and lack of muffler
10. Could simply switch to electric motor with solar panels and then just explain to visitors that they switched due to eco friendliness. This could influence others and make a difference.

Conversational Notes with Jose and Elsi (Project Manager)

- Current wood lasts 20 years, half a year ago some wood replaced
- Plastic wood doesn't do well in the heat
- 5 gallons through the wood wheels
- There is supposed to be gate on both sides to open/ close
 - During rainy season the gates are opened to move water
- Would like the idea of filling the ponds for a month to create salt to put on display and sell, then stop producing
- Can we look into stainless steel replacements
- Use grease to maintain but could look into other options for lubricant
- Rain mixes into oil
- Second house down the road needs to be redone, half visitors center and half employee section
- Some kind of solar system for AC or fans
- Ideas for parking lot material (least impact from car gases)

K. Interview: Lister Petter (Company)

We are students from Worcester Polytechnic Institute, a university in Massachusetts, U.S.A. We are currently conducting a project with the Fideicomiso de Conservacion (San Juan, PR). We are gathering information about the current water moving system in La Salinas Fortunas salt flats in Lajas. The motor is a 22 HP 1800 RPM Diesel motor, serial number 2776HA214. We were wondering if we could have a few minutes of your time? Participation in the research is voluntary. Participants may end their participation at any time. Participants need not answer every question in an interview or survey.

1. Can you provide us with the patent information for the motor with this serial number 2776HA214?
2. When was it made?
3. What were its purchasing and maintenance costs during that year?
4. Do you still make this model? If so, what are current expected maintenance costs? What are the common costs associated with repairing this motor?
5. What are common limitations and part failures, if any, associated with this motor?
6. What noise level read outs have you recorded with for this motors operation? (Reference to their website labeling the m as quiet)
7. What are noise control systems that can be applied to the motor? (Such as mufflers or baffling)
8. Is there an equivalent motor currently in production? If so, how much does it cost? What are current expected maintenance costs? What are the common costs associated with repairing this motor? RT2 and RT3?
9. Would you recommend that we repair or replace the current motor?

L. Minutes from Interview with Lister Petter and Realdiesel (Motor Company)

1. N/A
2. Motor Identification (information provided by Realdiesel)
 - 2776: Number off the line that production year
 - HA2: Motor type: 22hp at 1800rpm, 2 cylinder, air cooled, clockwise rotating diesel.
 - 14: Production year code: 1964
 - The official fuel consumption figures
 - Full load are 0.430 lb./bhp/ hr.
 - 3/4 load 0.442 lb. / bhp / hr
 - 1/2 load 0.498 / bhp / hr.
3. N/A
4.
 - (Information provided by both Lister and Realdiesel)
 - (Information provided by Lister)
 - HA2 is no longer made. Production 1959-1969
 - (information provided by Realdiesel)
 - Once sorted, maintenance is minimal: oil changes at the prescribed time, filters, valve clearance and that's about it
5. (Information provided by Realdiesel)
 - The first and simple rule of thumb test with these units is how well they start from cold. In good order, a few swings on the handle, drop a decompression lever, then the second one and you should be away. If you have to swing it for prolonged periods and/or get whitish exhaust vapor when trying, these are typical signs of diminished compression. Sometimes this may be down to valve seating issues, but more typically in a unit of this age will be bore wear.
 - At the age of the unit, one thing worth checking for is the presence of fuel oil in the sump oil. It is not uncommon as the injection pumps age that they start to leech traces of fuel into the sump. This is not a desirable state of affairs and indicates a need for replacement pumps.
 - The only potential issue [during repair] arises in the event of serious crankshaft wear, as some larger undersize bearings are becoming tricky to find. Be aware that fitment of the front and rear main bearings is significantly difficult without the appropriate tooling.

6. (Information provided by Realdiesel)
 - Exhaust noise, and then the more you spend on a silencer, the quieter it will become. If you are referring to ambient noise, then yes, they are quite a noisy engine and the only way around that if it is an issue is to fabricate a sound deadening enclosure. If you do, the key considerations must be the safe removal of exhaust gases, an adequate supply of combustion air and, equally important, an ample supply of cooling air and means of egress for the cooling air once passed through the engine.
7. NA
8. (Information provided by Realdiesel)
 - HR series engine is the later and last member of this [HA] family of engines, but as it is basically only a very slightly re-engineered version of yours (slightly more powerful, slightly bigger bearings, etc.) in terms of noise it is no different.
 - Personally I (Pete) wouldn't entertain using bio fuel. Any we have come across has been dirty, of hugely varying quality, filter clogging, smelly junk.
 - The HA was available in electric start form, but the presence of a motor aperture does not necessarily indicate the presence of a ring gear. We can supply whatever may be required for electric start, but be aware this is an expensive option -- several hundred Pounds.
9. (Information provided by Realdiesel)
 - If your engine starts well, by hand, that is a strong indicator of a good engine that doesn't need changing.
 - If you decide to refurbish your unit as required, there is no reason why you shouldn't get another forty odd years out of it.
 - We (realdiesel.co.uk) undertake all rebuild work if that is the direction you prefer, or can supply a fully rebuilt HA2 on an exchange basis.
 - We (realdiesel.co.uk) are able to supply all you are likely to require to rebuild the unit, if that is the preferred aim of the project.

M. Birds of La Parguera

FAMILY	SCIENTIFIC NAME	COMMON SPANISH NAME	COMMON ENGLISH NAME	ORIGIN	VOICE	HABITAT
Accipitridae	<i>Buteo jamaicensis</i>	Guaraguo Colirrojo	Red-tailed Hawk	Resident	“Keer”	Forested Areas



FAMILY	SCIENTIFIC NAME	COMMON SPANISH NAME	COMMON ENGLISH NAME	ORIGIN	VOICE	HABITAT
Accipitridae	<i>Pandion haliaetus</i>	Aguila de Mar	Osprey	Migratory	Slow, high pitched wistle	Near water



FAMILY	SCIENTIFIC NAME	COMMON SPANISH NAME	COMMON ENGLISH NAME	ORIGIN	VOICE	HABITAT
Ardeidae	<i>Ardea alba</i>	Garza Real	Great Egret	Resident	Squaks	Near water



FAMILY	SCIENTIFIC NAME	COMMON SPANISH NAME	COMMON ENGLISH NAME	ORIGIN	VOICE	HABITAT
Cathartidae	<i>Cathartes aura</i>	Aura Tiñosa	Turkey Vulture	Introduced	Hiss	Open area near cliff



FAMILY	SCIENTIFIC NAME	COMMON SPANISH NAME	COMMON ENGLISH NAME	ORIGIN	VOICE	HABITAT
Coerebidae	<i>Coereba flaveola</i>	Reinita común	Bananaquit	Resident	“zee-e-e swees se tee”	Trees or bushes



FAMILY	SCIENTIFIC NAME	COMMON SPANISH NAME	COMMON ENGLISH NAME	ORIGIN	VOICE	HABITAT
Columbidae	<i>Columbina passerina</i>	Rolita	Common Ground Dove	Resident	“woo-ah”	Open areas



FAMILY	SCIENTIFIC NAME	COMMON SPANISH NAME	COMMON ENGLISH NAME	ORIGIN	VOICE	HABITAT
Columbidae	<i>Zenaida aurita</i>	Tórtola Cardosantera	Zenaida Dove	Resident	“cuacoo-coo-coo”	Mangroves



FAMILY	SCIENTIFIC NAME	COMMON SPANISH NAME	COMMON ENGLISH NAME	ORIGIN	VOICE	HABITAT
Cuculidae	<i>Coccyzus minor</i>	Pájaro bobo menor	Mangrove Cuckoo	Resident	electric guitar	Thick vegetation



Cuculidae	<i>Crotophaga ani</i>	Judío / Garrapatero	Smooth-billed Ani	Resident	VOICE	HABITAT
Cuculidae	<i>Crotophaga ani</i>	Judío / Garrapatero	Smooth-billed Ani	Resident	“quee ick, kur-r-rk”	Open areas



FAMILY	SCIENTIFIC NAME	COMMON SPANISH NAME	COMMON ENGLISH NAME	ORIGIN	VOICE	HABITAT
Emberizidae	<i>Loxigilla portoricensis</i>	Comeñame	Puerto Rican Bullfinch	Endemic	Wistle followed by trill	Thick vegetation



FAMILY	SCIENTIFIC NAME	COMMON SPANISH NAME	COMMON ENGLISH NAME	ORIGIN	VOICE	HABITAT
Emberizidae	<i>Tiaris bicolor omissus</i>	Gorrión Negro	Black-faced Grassquit	Resident	“tseet”	Open areas



FAMILY	SCIENTIFIC NAME	COMMON SPANISH NAME	COMMON ENGLISH NAME	ORIGIN	VOICE	HABITAT
Estrildidae	<i>Lonchura cucullata</i>	Diablito / Pandillero	Bronze Mannikin	Introduced	“churring”	Low lands



FAMILY	SCIENTIFIC NAME	COMMON SPANISH NAME	COMMON ENGLISH NAME	ORIGIN	VOICE	HABITAT
Falconidae	<i>Falco sparverius</i>	Falcón Común	American Kestrel	Resident	“killy”	Open areas



FAMILY	SCIENTIFIC NAME	COMMON SPANISH NAME	COMMON ENGLISH NAME	ORIGIN	VOICE	HABITAT
Icteridae	<i>Icterus icterus</i>	Turpial	Troupial	Introduced	Wistle	Dry forest



FAMILY	SCIENTIFIC NAME	COMMON SPANISH NAME	COMMON ENGLISH NAME	ORIGIN	VOICE	HABITAT
Icteridae	<i>Quiscalus niger</i>	Chango / Mozambique	Greater Antillean Grackle	Resident	“tee tee”	Open area



FAMILY	SCIENTIFIC NAME	COMMON SPANISH NAME	COMMON ENGLISH NAME	ORIGIN	VOICE	HABIT AT
Mimidae	<i>Margarops fuscatus</i>	Zorzal Pardo	Pearly-eyed Thrasher	Resident	“wheur tel leur tsee”	Bushes



FAMILY	SCIENTIFIC NAME	COMMON SPANISH NAME	COMMON ENGLISH NAME	ORIGIN	VOICE	HABITAT
Mimidae	<i>Mimus polyglottos</i>	Ruiseñor	Northern Mockingbird	Resident	songs	Open areas



FAMILY	SCIENTIFIC NAME	COMMON SPANISH NAME	COMMON ENGLISH NAME	ORIGIN	VOICE	HABITAT
Muscicapidae	<i>Turdus plumbeus</i>	Zorzal de Patas Coloradas	Red-legged thrush	Resident	“wek wek”	Forests



FAMILY	SCIENTIFIC NAME	COMMON SPANISH NAME	COMMON ENGLISH NAME	ORIGIN	VOICE	HABITAT
Parulidae	<i>Dendroica discolor</i>	Reinita Galana	Prairie Warbler	Migratory	“tchick”	Edge of forest



FAMILY	SCIENTIFIC NAME	COMMON SPANISH NAME	COMMON ENGLISH NAME	ORIGIN	VOICE	HABITAT
Picidae	<i>Melanerpes portricensis</i>	Pájaro Carpintero de PR	Puerto Rican Woodpecker	Endemic	“wicka”	Forests



FAMILY	SCIENTIFIC NAME	COMMON SPANISH NAME	COMMON ENGLISH NAME	ORIGIN	VOICE	HABITAT
Thraupidae	<i>Euphonia musica sclateri</i>	Jilguero	Antillean Euphonia	Resident	“chit it”	Low and dry scrub forests



FAMILY	SCIENTIFIC NAME	COMMON SPANISH NAME	COMMON ENGLISH NAME	ORIGIN	VOICE	HABITAT
Thraupidae	<i>Spindalis portoricensis</i>	Reina Mora	Puerto Rican Spindalis	Endemic	“tseet”	forests



FAMILY	SCIENTIFIC NAME	COMMON SPANISH NAME	COMMON ENGLISH NAME	ORIGIN	VOICE	HABITAT
Todidae	<i>Todus mexicanus</i>	San Pedrito de PR	Puerto Rican Tody	Endemic	“pree”	forests



FAMILY	SCIENTIFIC NAME	COMMON SPANISH NAME	COMMON ENGLISH NAME	ORIGIN	VOICE	HABITAT
Trochilidae	<i>Chlorostilbon maugaeus</i>	Zumbadorcito de PR	Puerto Rican Emerald	Endemic	High pitched squeel	forests



FAMILY	SCIENTIFIC NAME	COMMON SPANISH NAME	COMMON ENGLISH NAME	ORIGIN	VOICE	HABITAT
Tyrannidae	<i>Contopus latirostris blancoi</i>	Bobito Antillano Menor	Lesser Antillean Pewee	Resident	“pree-e-e-e”	forests



FAMILY	SCIENTIFIC NAME	COMMON SPANISH NAME	COMMON ENGLISH NAME	ORIGIN	VOICE	HABITAT
Tyrannidae	<i>Elaenia martinica riisii</i>	Jui blanco	Caribbean Elaenia	Resident	“peweer”	Lower part of trees



FAMILY	SCIENTIFIC NAME	COMMON SPANISH NAME	COMMON ENGLISH NAME	ORIGIN	VOICE	HABITAT
Tyrannidae	<i>Tyrannus dominicensis</i>	Pitirre gris	Gray Kingbird	Resident	“pitirre”	Open areas



FAMILY	SCIENTIFIC NAME	COMMON SPANISH NAME	COMMON ENGLISH NAME	ORIGIN	VOICE	HABITAT
Vireonidae	<i>Vireo latimeri</i>	Bien-te-veo	Puerto Rican vireo	Endemic	“bien-te-veo”	Forest



(Fideicomiso) (Oberle)

N. Materials Matrix

Material	Name	Possible Uses
Wood	Bamboo	House, Stations, Center, Boardwalk
	Reclaimed Indonesian Hardwood	House, Stations, Center, Boardwalk
	Mahogany	House, Stations, Center, Boardwalk
	Oak	House, Stations, Center, Boardwalk
Wood Alternatives	Geo Deck	House, Stations, Center, Boardwalk
	i-plas	House, Stations, Center, Boardwalk
	Kirei Board	House, Stations, Center, Boardwalk
	Trex	House, Stations, Center, Boardwalk
	Natural Fiber Boards	House, Stations, Center, Boardwalk
Wood Sealants	Rubio Monocoat Oil Plus	Structures made of wood
	PolyWhey Natural Wood Finish	Structures made of wood
Lubricants	SoyGrease EP Premium	Machine Parts
	SoyGrease HiTemp	Machine Parts
	TempFlex 0 to 100	Machine Parts
	SoyGrease Semi Truck Fifth Wheel	Machine Parts
	BERUGEAR UWS FG 34-00	Machine Parts
Foundations	Dirt Glue	Foundation of Structures
	Eco-Cement	Foundation of Structures
	Granite Crete	Foundation of Structures
	Gravel Pave	Parking Lot
	Drivable Grass	Parking Lot
Sound Proofing	Decibel Drop	Inside House
	Barrier	Inside House
	Composite	Inside House
	Valueline Baffles	Inside House
	Bioline	Inside House
Currently in Use	Pine	House, Stations, Center, Boardwalk
	Ausubo	House, Stations, Center, Boardwalk
	Teak	House, Stations, Center, Boardwalk
	PVC Wood	House, Stations, Center, Boardwalk
	Sand	Foundation of Structures
	Concrete	Foundation of Structures

Name	Environmental Friendliness							%	
	Heat Island Impact	Recycled	Low Emitting	Rapidly Renewable	Pollution Protectant	Biodegradable	Water Resistant		Recyclable
Bamboo	X		X	X					37.5
Reclaimed Indonesian Hardwood	X								12.5
Mahogany				X					12.5
Oak			X	X					25
Geo Deck		X						X	25
i-plas		X						X	25
Kirei Board		X	X	X					37.5
Trex		X	X					X	37.5
Natural Fiber Boards		X	X	X					37.5
Rubio Monocoat Oil Plus			X						12.5
PolyWhey Natural Wood Finish			X					X	25
SoyGrease EP Premium						X	X	X	37.5
SoyGrease HiTemp	X					X			25
TempFlex 0 to 100		X				X			25
SoyGrease Semi Truck Fifth Wheel	X					X	X		37.5
BERUGEAR UWS FG 34-00						X			12.5
Dirt Glue					X				12.5
Eco-Cement	X	X						X	37.5
Granite Crete	X	X							25
Gravel Pave	X								12.5
Drivable Grass	X				X				25
Decibel Drop					NA				0
Barrier					NA				0
Composite					NA				0
Valueline Baffles					NA				0
Bioline		X	X						25
Pine									0
Ausubo									0
Teak									0
PVC Wood					NA				0
Sand									0
Concrete									0

Name	Cost (\$)	Cost Converted to SI	Contacts	Location	
				Imported	Local
Bamboo	80-90 / (11x11)	1089.75 / sq m	VIFAH U.S. Showroom. New York, NY 10001	X	
Reclaimed Indonesian Hardwood	17 / sq ft	182.8 / sq m	San Juan Ventures. Lake Forest, IL 60042	X	
Mahogany	4.50 / sq ft	48.4 / sq m	Gulf Lumber, Inc. Carolina, PR.		X
Oak	5 / (4x4)	500 / sq m	Woodworkers Source. Arizona	X	
Geo Deck	3 / ft	32.25 / sq m	GeoDeck. Green Bay, WI 54304	X	
i-plas	NA	NA	i-plas. Halifax, West Yorkshire	X	
Kirei Board	10-14 / sq ft	129 / sq m	Kirei USA. Solana Beach, CA 92075	X	
Trex	4 / ft	43 / sq m	The Deck Store. Apple Valley, MN.	X	
Natural Fiber Boards	NA	NA	Golden Vetiver Grass Board. Bangbon Bankok	X	
Rubio Monocoat Oil Plus	4.5 / sq ft	116 / L	Special Hardwood Products. Lithonia, GA 30058	X	
PolyWhey Natural Wood Finish	30 / qt	.03 / g	Vermont Natural Coatings. Hardwick, VT 05843	X	
SoyGrease EP Premium	4.75 / tube	4.75 / tube	Environmental Lubricants Manufacturing, Inc. Grundy Center, IA 50638	X	
SoyGrease HiTemp	3.83 / tube	3.83 / tube	Environmental Lubricants Manufacturing, Inc. Grundy Center, IA 50639	X	
TempFlex 0 to 100	120 / pale	120 / pale	Environmental Lubricants Manufacturing, Inc. Grundy Center, IA 50640	X	
SoyGrease Semi Truck Fifth Wheel	132.24 / pale	132.24 / pale	Environmental Lubricants Manufacturing, Inc. Grundy Center, IA 50641	X	
BERUGEAR UWS FG 34-00	NA	NA	BEICHEM Lubrication Technology. Hagen, Germany.	X	
Dirt Glue	15 / gal	3.96 / L	DirtGlue Enterprises. Amesbury, MA 01913	X	
Eco-Cement	NA	NA	TecEco Pty.Ltd. Tasmania, Australia	X	
Granite Crete	55 / 85 lb bag	1.43 / kg	GraniteCrete. Carmel Valley, CA 93924	X	
Gravel Pave	5.85 / sq ft	62.9 / sq m	Invisible Structures. Golden, CO 80401	X	
Drivable Grass	3 / sq ft	32.25 / sq m	Soil Retention Products, Inc. Carsbad, CA 92008	X	
Decibel Drop	179 / 12, 1 quart tubes	179 / 11355 mL	Pinta Acoustic, Inc. Minneapolis, MN 55430	X	
Barrier	911 / 1 roll (48x720 by 1/4 thick)	41.41 / sq m	Pinta Acoustic, Inc. Minneapolis, MN 55430	X	
Composite	153 / 1 box of 2 (24x48 by 11/8 thick)	104.80 / sq m	Pinta Acoustic, Inc. Minneapolis, MN 55430	X	
Valueline Baffles	242 / 1 box of 8 (24x48 by 3/2 thick)	41.50 / sq m	Pinta Acoustic, Inc. Minneapolis, MN 55430	X	
Bioline	11 / sq ft	118.27 / sq m	Pinta Acoustic, Inc. Minneapolis, MN 55430	X	
Pine	4.50 / sq ft	48.4 / sq m	Gulf Lumber, Inc. Carolina, PR.		X
Ausubo	NA	NA	Constructora Ausubo, Inc. Caguas, PR.		X
Teak	200 / 20 bd.ft	262.5 / sq m	Pro Teak Renewable Forestry. Wimerly, TX	X	
PVC Wood	78.95 / (4x8 by 3/4 thick)	5093.5 / sq m	Los Portales de Madeco, Inc. Cupe, PR.		X
Sand	8-10 / tonne	9.93 / Mg	VOP Consulting and Brokerage Inc. Guaynabo, PR.		X
Concrete	8-10 / tonne	9.93 / Mg	VOP Consulting and Brokerage Inc. Guaynabo, PR.		X

Name	All encompassing	
	Points	Final Recommendation
Bamboo	3	
Reclaimed Indonesian Hardwood		
Mahogany	1	
Oak		
Geo Deck	2	
i-plas		
Kirei Board	3	
Trex	3	
Natural Fiber Boards	3	
Rubio Monocoat Oil Plus		
PolyWhey Natural Wood Finish	3	Wood Sealants
SoyGrease EP Premium	3	Machine Parts
SoyGrease HiTemp	2	
TempFlex 0 to 100		
SoyGrease Semi Truck Fifth Wheel	3	Machine Parts
BERUGEAR UWS FG 34-00		
Dirt Glue		
Eco-Cement	3	
Granite Crete	2	
Gravel Pave	3	Parking Lot
Drivable Grass	2	
Decibel Drop		
Barrier	2	
Composite		
Valueline Baffles	2	
Bioline	3	Inside the House
Pine	4+1 = 5	Infrastructures
Asubo	4+1 = 5	Infrastructures
Teak	4	
PVC Wood	4+1 = 5	Infrastructures
Sand	4+1 = 5	Foundations
Concrete	4+1 = 5	Foundations

O. LEED Certified Material Descriptions

Reclaimed Indonesian Hardwood



WOOD & PLASTICS

What is it?

Aged hardwood reclaimed from Indonesia

Where can I use it?

Beams, flooring, furniture, sculptural elements

Why is it green?

All of San Juan Ventures' FSC-certified reclaimed wood is sourced from native Indonesian structures called *joglos* and from abandoned factories that used wood for supports and foundations. They also get ulin, or ironwood, from boat beams and utility poles.

The aptness of the name *ironwood* is apparent as soon as it is picked up. A section about the size of a bowling ball weighed over 25 pounds. San Juan works with locals to source the wood in order to respect the potential and beauty of these specimens. This material is exceptionally beautiful and conveys a history that modern materials cannot.

Special Considerations

Fifty percent of all wood products used in a project must be FSC certified in order to qualify for LEED credit.

LEED Credits

+ MR 3
Materials Reuse

+ MR 7
Certified Wood

Information

San Juan Ventures
P.O. Box 471
Lake Forest, IL 60042
P 847 234 2832

Kirei Board

WOOD & PLASTICS



LEED Credits

- + MR 4
Recycled Content
- + MR 6
Rapidly Renewable Materials
- ▣ IEQ 4.4
Low-Emitting Materials—
Composite Wood and
Agrifiber Products

Information

Kirei USA
412 North Cedros Avenue
Solana Beach, CA 92075
T: 619 236 9924
F: 240 220 5946
info@kireiusa.com
www.kireiusa.com

What is it?

Environmentally friendly finishing material

Where can I use it?

Flooring, cabinetry, furniture

Why is it green?

Kirei Board is made from sorghum straw and is a great alternative to other wood products. Sorghum stalks are the waste product left after the usable parts of the plant (used as feed) are harvested. These stalks would normally be taken to a landfill or burned. This produces a uniquely eco-sensitive building product; not only is it a rapidly renewable resource, since it is harvested on an annual basis, but turning the discarded stalks into a building material makes it recycled content as well.

Sorghum straw makes up 90 percent of Kirei Board. The material is bonded together using a nontoxic adhesive that does not include any added urea formaldehyde, and they also use a water-based adhesive, KR Bond, to finish the boards. They can be cut, nailed, or screwed just like standard wood panels. Since it is a finished material, no further painting or design elements are needed once installed.

9ef7ccf32b74d3a300b74289d2e6e21c2 ebruary **GeoDeck** 3b4289d2e6e21c2



WOOD & PLASTICS

What is it?

Composite decking and railing system

Where can I use it?

Outdoors decks

Why is it green?

GeoDeck is a decking and railing system made from a mix of recycled materials, including polyethylene and cellulose fiber, as well as calcium carbonate and clay. It comes in standard wood finishes and can be cut, milled, drilled, and fastened like any ordinary decking material. Its light weight makes it easier to work with and cuts down on transportation costs. A material made mostly from recycled content, GeoDeck is easily recyclable with general construction debris—things that are made from recycled content can easily be recycled again.

Special Considerations d2e6e21c2

9ef7ccf32b74d3a300b74289d2e6e21c2
ebruary *A lighter color will absorb less heat and possibly make the deck area more comfortable.*

LEED Credits

9ef7ccf32b74d3a300b74289d2e6e21c2
ebruary

+ MR 2
Construction Waste
Management

+ MR 4
Recycled Content

Information

GeoDeck
1518 South Broadway
Green Bay, WI 54304
T 877 804 0137
info@geodeck.com
www.geodeck.com

Natural Fiber Boards

WOOD & PLASTICS

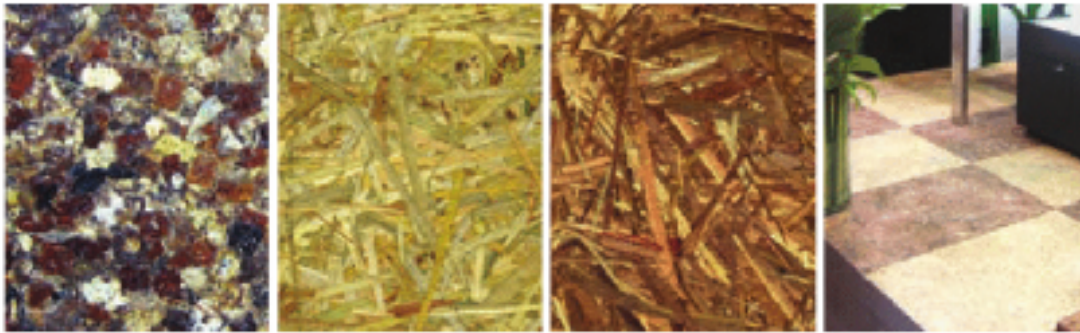

LEED Credits

+ MR 4

Recycled Content

+ MR 6

Rapidly Renewable Materials

▣ IEQ 4.4

Low-Emitting Materials—
Composite Wood and
Agrifiber Products

Information

Golden Vetiver Grass Board
Industry

55/121 Soi 76/1 Ekkachai Road
Bangbon Bangkok
10150

Thailand

T +662 500 5899

F +662 415 9201

marketing@golden-board.com

parinda@golden-board.com

www.golden-board.com

What is it?

Composite panels made from renewable and recycled materials

Where can I use it?

Flooring, wall coverings, furniture, partitions, countertops

Why is it green?

Golden Vetiver Grass Board Industry, based in Thailand, uses locally sourced waste products to produce environmentally friendly wood-panel alternatives. They have several products made up of mangosteen peels, orange peels, lemongrass, wood chips, rice hulls, and vetiver grass.

The company grinds these up and binds them with a nontoxic polymeric diphenylmethane diisocyanate adhesive (pMDI). The result is a building panel that can be cut and fastened using standard tools and maintains the character and appearance of the materials it is made of. Making a countertop out of orange peels or rice hulls adds contextual character to a room that stone or composite products can't compete with.



LEED Credits

+ MR 2

Construction Waste Management

+ MR 4

Recycled Content

Information

i-plas
Ridings Business Park
Hopwood Lane
Halifax, West Yorkshire
HX1 3TT
United Kingdom
T +44 1422 350816
F +44 1422 347524
sales@i-plas.co.uk
www.i-plas.co.uk

What is it?

Plastic lumber

9ef7ccf32b74d1a923b4289d2e6e21c2
ebruary

Where can I use it?

Outdoor furniture, boardwalks, ground protection, in place of lumber

Why is it green?

The UK-based company i-plas makes lumber products from 100 percent recycled and recyclable plastics that would otherwise find their way to a landfill. Plastic lumber offers several advantages over standard timber products. According to the company, it lasts five times longer and is rot-, algae-, chip-, splinter-, crack-, insect-, and rodent-proof, making it a maintenance-free option. It can be worked with and installed just like standard lumber and will hold nails and screws just as well.

Special Considerations

At the time of this writing, the company had not yet established global distribution.

DirtGlue



SITE CONSTRUCTION

What is it?

Soil-stabilization polymer

Where can I use it?

Preventing soil erosion, natural paths

Why is it green?

DirtGlue is a compound that makes soil particles bind to form a flexible film over the soil. Construction activity can cause soil degradation and can pollute groundwater and nearby streams. DirtGlue takes the dust that trucks kick up that might enter the air during construction to create a film that prevents soil erosion. DirtGlue is water soluble and nonhazardous, so it can be applied anywhere, including near river beds, without harming land animals or aquatic life. The compound comes in two versions: DirtGlue Light is applied to the surface of the soil for basic protection from mechanical damage from vehicles or equipment, wind, or water erosion, and can be used to temporarily cap dirt piles. DirtGlue Industrial is mixed with the soil to form a sturdier surface that can withstand the punishing effects of heavy construction vehicles and long-term abuse.

Special Considerations

The compound may need to be reapplied after heavy usage.

LEED Credits

© SS P1

Construction Activity
Pollution Protection

Information

DirtGlue Enterprises
83 Middle Road
Amesbury, MA 01913
T 978 388 3312
F 508 861 0550
customerservice@dirtglue.com
www.dirtglue.com

Drivable Grass

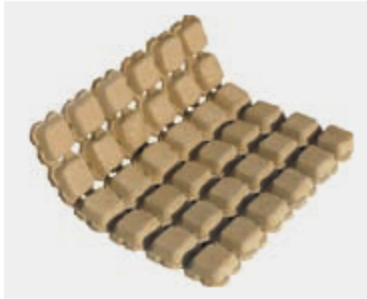

LEED Credits

© **SS P1**

Construction Activity
Pollution Prevention

© **SS 6.1**

Stormwater Design—
Quantity Control

© **SS 7.1**

Heat Island Effect—Nonroof

Information

Soil Retention Products, Inc.
2501 State Street
Carlsbad, CA 92008
T 800 346 7995
sales@soilretention.com
www.soilretention.com

What is it?

Paving system

Where can I use it?

Parking areas, driveways

Why is it green?

Drivable Grass consists of flexible mats of small concrete blocks that can be laid down by anyone as it requires no special skills. They come in roughly 2 x 2 foot sections, which can be used to make anything from a small driveway to a large parking area. The system is completely modular—you just lay them down one next to the other, then grass freely grows between the blocks, filling in the spaces while maintaining an even, sturdy surface for vehicles to traverse. The mats can be installed during construction for soil retention, then be left in place as a permanent surface. The spaces between the concrete allow for unrestricted drainage of stormwater and also eliminate the heat-island effect that dark asphalt can produce.

Special Considerations

Some municipalities will not allow this type of surface because it may violate specific building codes or hinder handicap access.

Bioline

WOOD & PLASTICS



LEED Credits

+ MR 4
Recycled Content

▣ IEQ 4.4
Low-Emitting Materials—
Composite Wood and
Agrifiber Products

Information

Pinta Acoustic, Inc.
2601 49th Avenue North
Suite 400
Minneapolis, MN 55430
T 612 355 4250 / 800 662 0032
(United States and Canada only)
F 612 355 4255
sales@pinta-acoustic.com
www.pinta-acoustic.com

What is it?

Wood ceiling tiles

Where can I use it?

Ceilings

Why is it green?

Bioline ceiling tiles come in two lines, Solid Finish and Organic Texture. The Solid Finish line has finish veneers like maple, bamboo, and cherry, and contains 70 percent recycled content; while the Organic Texture line comes in three different shades of natural wood and contains 80 percent recycled content. Organic Texture can provide acoustic insulation by reducing reverberation by up to 80 percent. The recycled content is preconsumer, so it will only count for half in the credits, and the panels have no added urea formaldehyde. Urea formaldehyde has been shown to be highly toxic to our respiratory systems. The panels come in standard sizes of 2 x 2 feet, 2 x 4 feet, and 2 x 6 feet, or can be custom-made.

SITE CONSTRUCTION



LEED Credits

⊙ SS 7.1

Heat Island Effect—Nonroof

+ MR 2

Construction Waste Management

+ MR 4

Recycled Content

⊛ ID 1

Innovation in Design

Information

TecEco Pty. Ltd.

497 Main Road

Glenorchy

Tasmania 7010

Australia

T +61 3 62497868

F +61 3 62730010

www.teccoco.com

What is it?

CO₂-absorbing cement. ec5f29f028cc085c6627b581e2452
ebruary

Where can I use it?

Anywhere you use cement

Why is it green?

Concrete manufacturing is one of the worst producers of greenhouse gases in the world. Each year, it generates more carbon pollution than the entire aviation industry—5 percent of all the world's emissions.

TecEco introduces magnesia into their concrete mix along with recycled materials like fly ash. When magnesia is mixed in with the Portland cement, it takes on an amazing property, and as it cools and cures, it absorbs CO₂ and sequesters it permanently. Each kilogram of Eco-Cement made results in net carbon emissions of 0.23 kilograms. Constructing a building with Eco-Cement blocks or paving a parking lot with the light-colored cement (which also eliminates the heat-island effect) helps remove greenhouse gases from the atmosphere. The credits that LEED gives for this material are not related to its most important property of helping to fight global warming.

SITE CONSTRUCTION



LEED Credits

⊙ **SS 6.1**

Stormwater Design—
Quantity Control

⊙ **SS 6.2**

Stormwater Design—
Quality Control

⊙ **SS 7.1**

Heat Island Effect—Nonroof

+ **MR 4**

Recycled Content

Information

GraniteCrete

4 Buena Vista Del Rio

Carmel Valley, CA 93924

T 800 670 0849

info@granitecrete.com

www.granitecrete.com

What is it?

Pavement alternative: 8ec5f29f028cc085c6627b581e24529
ebruary

Where can I use it?

Walkways, paths, driveways

Why is it green?

GraniteCrete is a sustainable hardscape solution with multiple benefits. It is made from a mixture of colorants, natural clays, and preconsumer recycled granite—the exact specifications of which are a trade secret. The material costs roughly one-third of what concrete does and is installed by simply laying it over a bed of gravel and then compacting it, making it immediately available for use. No special tools or skills are needed to install it, and it can be removed with a pickaxe if the need should arise. The mixture is available in six different earth tones that negate the heat-island effect, and its sandlike composition allows stormwater to drain through rather than running off and polluting other areas. Because of its porous nature, it acts as an effective filter for waste that would otherwise pollute the aquifer.



SITE CONSTRUCTION

What is it?

Soil retention and alternative paving system.

Where can I use it?

Parking lots, driveways, walkways

Why is it green?

Gravelpave² is a structure onto which loose gravel is placed to create a solid surface that allows stormwater to drain while filtering larger pollutants before they can infiltrate groundwater. Also, using a light-colored stone, such as a light gray crushed peastone, can prevent the heat-island effect that is created by more traditional paving surfaces, such as black asphalt. Using gravel is also much more cost effective than asphalt or concrete, contrary to the common conception that building green has to be expensive.

Special Considerations

Some municipalities will not allow this type of surface because it may violate specific building codes or hinder handicap access.

LEED Credits

© **SS 6**

Stormwater Design—
Quantity Control

© **SS 6.2**

Stormwater Design—
Quality Control

© **SS 7.1**

Heat Island Effect—Nonroof

Information

Invisible Structures
1600 Jackson Street
Suite 310
Golden, CO 80401
T 303 233 8383
dustin@invisiblestructures.com
www.invisiblestructures.com

Rubio Monocoat Oil Plus

WOOD & PLASTICS



LEED Credits

■ IEQ 4.2

Low-Emitting Materials—
Paints and Coatings

Information

Special Hardwood Products Inc.
2211 Lithonia Industrial
Boulevard
Lithonia, GA 30058
T 877 928 9663
sales@specialhardwood.com
info@monocoat.us
www.specialhardwood.com

What is it?

Nontoxic wood sealant

Where can I use it?

Flooring

Why is it green?

Rubio Monocoat Oil Plus forms a long-lasting, durable, molecular-level bond with wood fibers. It comes in forty standard tints and can be applied without any special skills. It contains no VOCs and is water and heat resistant, making it ideal for kitchens or bathrooms. This natural vegetable oil forms such a complete bond (in only 15 seconds) with the wood that a second coat is unnecessary. This eliminates the need for overlapping brush strokes (since the additional coat would just wash off), or different saturation levels and tints.

Special Considerations

When preparing a submittal for the Low-Emitting Materials credit, you must provide the product name, VOC levels, and source of that information.

7ccf32b74d1a923b4289d2e6e21c2 PolyWhey Natural Wood Finish

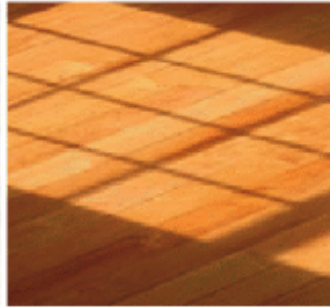

WOOD & PLASTICS

What is it?

Nontoxic wood finish

Where can I use it?

Wood floors, wood furniture

Why is it green?

PolyWhey is a wood finish that is easy to apply and that dries quickly. It has less than 180 g/L VOCs, making it compliant the Low-Emitting Materials (sealant) credit. When working with sealants and adhesives, it is usually a good idea to wear breathing protection. However, no protection is necessary with this sealant since it contains such a small amount of VOCs. Vermont Natural Coatings decided to go that extra step and make their cans from postconsumer recycled materials; they can be easily recycled when they are emptied, which contributes to the Construction Waste Management credit.

7ccf32b74d1a923b4289d2e6e21c2
ary

LEED Credits

9ef7ccf32b74d1a923b4289d2e6e21c2
ebruary

+ MR 2

Construction Waste Management

▣ IEQ 4.1

Low-Emitting Materials—
Adhesives and Sealants

Information

Vermont Natural Coatings
180 Junction Road
Hardwick, VT 05843
T 802 472 8700
F 802 472 5227
www.vermontnatural
coatings.com