

Purradise City: A Catboy-Themed Citybuilding Digital Board Game

A Major Qualifying Project Submitted to the Faculty of
Worcester Polytechnic Institute
in partial fulfillment of the requirements for the

Degree of Bachelor of Science
in Interactive Media and Game Design
and for the
Degree of Bachelor of Science
in Computer Science
and for the
Degree of Bachelor of Arts
in Interactive Media and Game Design

By

Kateri Bajer

Zack Koval

Erin Marczewski

Percy Rynkowski

Date: 4/27/23

Project Advisors:

Professor Rose Bohrer, Advisor

Professor Adryen J. Gonzalez, Advisor

Professor Ben Schneider, Advisor

This report represents work of WPI undergraduate students submitted to the faculty as evidence of a degree requirement. WPI routinely publishes these reports on its website without editorial or peer review. For more information about the projects program at WPI, see

<http://www.wpi.edu/Academics/Projects>.

Abstract

Purradise City is a four-player digital board game with a focus on cooperative city-building featuring catboy characters. It was created in Unity and features a combination of tile-based board mechanics, cards, and resource management. The following report details our design process, the game's mechanics, our technical implementation, our production of art assets, the feedback we received during playtests, and our final thoughts on the project and what could be improved in the future. With over 100 cards featuring unique art, 16 playable characters, and a wide array of deep mechanics, we believe *Purradise City* is a successful entry into the world of pass-and-play games.

Acknowledgments

We would like to first acknowledge our advisors Rose Bohrer, Adryen J. Gonzalez, and Ben Schneider who provided us with invaluable assistance and guidance throughout this project.

We would also like to acknowledge the dozens of individuals who agreed to playtest our game and provided us with feedback on how we could improve going forward.

On a more personal level, we would like to acknowledge those who have supported us emotionally through our respective academic journeys, including Andrzej and Kinga Bajer.

Table of Contents

Abstract.....	3
Acknowledgements.....	4
Table of Contents.....	5
List of Figures.....	8
Chapter 1: Introduction.....	9
1.1 Inspirations/Concepts.....	9
1.2 Pre-Production.....	11
Chapter 2: Design.....	12
2.1 Experience Goals.....	12
2.2 Comparables.....	12
2.3 Premise.....	13
2.3.1 Theming.....	14
2.3.2 Factions.....	15
2.3.3 Use of textual cat puns.....	15
2.4 Mechanics.....	16
2.4.1 Core gameplay loop.....	16
2.4.2 Resource management.....	17
2.4.3 Tags.....	18
2.4.4 Zoning laws.....	18
2.4.5 Factions.....	18
Chapter 3: Technical Implementation.....	19
3.1 Software/Engine.....	19
3.2 Version control.....	19
3.3 Game class structures.....	19
3.3.1 The action system.....	19
3.3.2 The player system.....	20
3.3.3 The management system.....	20
3.4. Flow of the Game.....	21
3.5 User Interface.....	22
3.6 Milestones.....	23
3.6.1 ProtoFest.....	23
3.6.2 AlphaFest.....	23
3.6.3 Vertical slice.....	23
3.6.4 Beta.....	24
Chapter 4: Art.....	25
4.1 Concepts.....	25

4.2 Color palettes.....	25
4.3 Character art.....	27
4.4 Environment art.....	28
4.4.1 Tiles and borders.....	29
4.4.2 Buildings.....	29
4.5 User interface.....	31
4.6 Cards.....	32
4.6.1 Card UI.....	32
4.6.2 Card art.....	33
4.7 Logos and icons.....	34
4.7.1 Game logo.....	34
4.7.2 In-game resources.....	35
4.7.3 Tags.....	36
4.7.4 City metrics.....	36
4.7.5 Use of visual cat puns.....	36
Chapter 5: Sound design.....	38
Chapter 6: Playtesting & Showcasing.....	39
6.1 Reactions.....	39
6.2 Takeaways.....	39
6.3 Applying feedback to the game.....	40
Chapter 7: Post-Mortem and Conclusion.....	42
7.1 What went wrong.....	42
7.1.1 Little to no plan going into the project.....	42
7.1.2 Too much time spent in design phase.....	42
7.1.3 Lines of communication were fixed, but a little too late.....	42
7.1.4 Lack of cohesion in art styles.....	43
7.1.5 Effects that do not translate well to a digital space.....	43
7.1.6 Hard to present at ShowFest.....	44
7.1.7 Sometimes life has to come first.....	44
7.2 What went right.....	44
7.2.1 Solid design phase.....	45
7.2.2 Clear communications about artistic vision.....	45
7.2.3 Lots of playtests, lots of feedback.....	45
7.2.4 Audio as an afterthought.....	46
7.2.5 Scrapping the story.....	46
7.2.6 Successful scope cuts.....	46
7.2.7 Four term MQP.....	46
7.3 Cut content and future features.....	47

7.3.1 Building scoring.....	47
7.3.2 Upgrade cards.....	47
7.3.3 Time Purriod effects.....	47
7.3.4 Event cards based on placed buildings.....	48
7.4 Conclusion.....	48
Bibliography.....	49
Appendix A: Design document.....	51
Appendix B: A Term timeline.....	62
Appendix C: B Term timeline.....	65
Appendix D: C Term timeline.....	69
Appendix E: D term timeline.....	71
Appendix F: Asset list.....	73
Appendix G: Art bible.....	86

List of Figures

Figure 1 - Cheshire, a character in Pandora Hearts.....	9
Figure 2 - Furry Scale.....	10
Figure 3 - The game screen of Terraforming Mars.....	13
Figure 4 - The characters of Hustle Cat.....	15
Figure 5 - The core gameplay loop of Purradise City.....	17
Figure 6 - Characters from Dandelion Wishes Brought to You.....	25
Figure 7 - Purradise City's color guide.....	26
Figure 8 - The cult faction of Purradise City.....	27
Figure 9 - A lineup of Purradise City characters. From left to right: the music faction, the mercenary faction, the mafia faction, and the church faction.....	28
Figure 10 - Purradise City grass tile.....	29
Figure 11 - Purradise City building blocks.....	30
Figure 12 - A selection of Purradise City buildings. From left to right: the nightclub, the space station, the cathedral, and the meownsion.....	31
Figure 13 - Purradise City's user interface and game screen.....	31
Figure 14 - The layout of cards in Purradise City.....	32
Figure 15 - Two Purradise City cards, Nekomancy and Catnap.....	34
Figure 16 - Purradise City's two logos.....	35
Figure 17 - Purradise City's five resources. From left to right: money, material, labor, public relations, and suspicion.....	35
Figure 18 - Examples of Purradise City tag icons. From left to right: food, occult, underbelly, education, and corporate.....	36
Figure 19 - The city metric icons in Purradise City. From left to right: wealth, population, culture, and morale.....	36
Figure 20 - The Purradise City card Fishy Deals.....	37

Chapter 1: Introduction

1.1 Inspirations/Concepts

The original concept of *Purradise City* arose from the idea of a "catboy themed game". The terms "catboy" and "catgirl" are commonly used in modern media to refer to characters that are mostly human with certain feline features, mainly the ears and tail of a cat. Catboys are often featured in anime - Japanese animation - as well as games, and commonly display prominent cat-like personality traits. Figure 1 (Mochizuki, 2006) shows Cheshire, a character from Jun Mochizuki's manga *Pandora Hearts* who exemplifies the typical catboy. We as a team decided it would be fun to make a game that features an entire cast of catboys, as well as figure out how to build a believable setting where humans are replaced with cat-people.



Figure 1 - Cheshire, a character in *Pandora Hearts*

Catboys are generally considered in the western hemisphere to be a type of furry. The furry community is a largely internet-based culture of individuals who strongly associate themselves with an animal and choose to identify as that animal in their online presence. However, "furry" can also refer to the concept of anthropomorphized animal characters in

modern media, a well-known example being the characters in Disney's *Zootopia*. Even if this film was not intended to target the furry audience, it has been appropriated by furry culture due to the designs of its characters. *Zootopia's* characters are a four on the scale shown in Figure Two, while our catboys were designed to be at a one, the "nekomimi" side of the spectrum, or a one on Figure 2 shown below (かゝb, 2010). Nekomimi is a Japanese term that refers to characters that are almost entirely human aside from certain animal traits. They are much more human in appearance than the fully anthropomorphic characters usually seen in the furry community, and instead feature more prominently in anime.

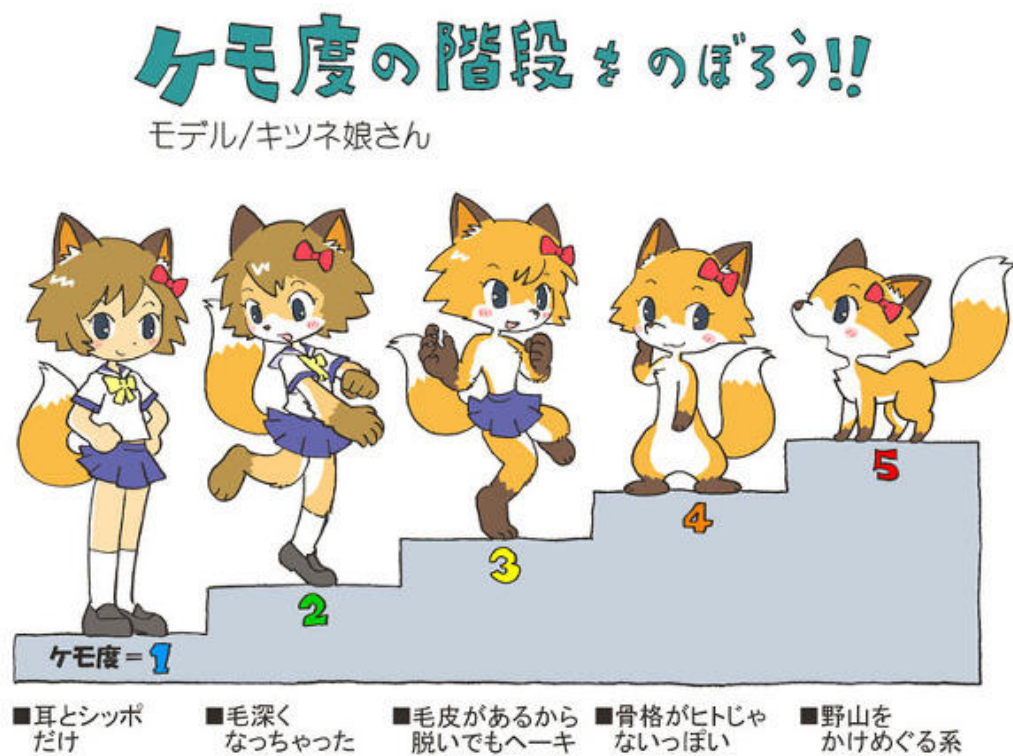

Figure 2 - Furry Scale.

Purradise City was originally conceptualized as a dating sim, a type of game that allows the player to virtually date its characters. During our initial brainstorming phase, the team came up with a few other ideas for types of games. We were not married to the idea of a dating sim and wanted to explore our options. This ended up being quite beneficial, as we decided that we would rather create a more mechanically complex and interesting game. To this end, we landed on the engine-building genre of game, where players spend resources in order to build up

something - in our case, a city. We figured this would mesh well with a multiplayer board game style, and would be a great way to show each team member's individual skills.

1.2 Pre-Production

We dedicated a great amount of time - almost the whole of A term - to determining the game's mechanics and playstyle. One of our greatest hurdles in creating a digital board game was designing the mechanics. We were worried about unintentionally creating a game that was not fun for people to play since it is so easy for board games to become overly complex and incredibly long. Thus, we felt it would be best for us to dedicate the entirety of A term to the design of the game. This way, we could spend a large amount of time designing the mechanics and playstyle, as well as testing whether we and other playtesters found the game fun. This allowed us to be certain of the success of our mechanical design before we spent time implementing features that may not have been fun for players. This also allowed us to avoid issues where team members would be awaiting the design of features and be forced to rush the game's design in order to get other features implemented. For other projects, dedicating this much time to the game's design might have been a bit excessive - but we felt it necessary for this project to be able to nail down our most important mechanical elements.

The game was initially designed on paper. We created a paper map and hundreds of index cards with card information hand-written on them. This paper version of the game was instrumental in allowing us to test our game before starting on a digital build. With this, we could confidently go into designing the digital version in the coming terms.

Chapter 2: Design

2.1 Experience Goals

Purradise City focuses on creating a light-hearted, yet competitive, experience with cute catboy aesthetics. We define "cute" in a similar way to the Japanese term "kawaii", which is often used in the English lexicon to refer to pastel, bubbly, and sometimes magical aesthetics. The term is often used in conjunction when talking about catboys, so we found it appropriate to use this type of aesthetic. While normally a more serious and strategic genre, *Purradise City*'s priority is creating a gameplay loop that is fun to play and easy to pick up. While the game has a decent amount of complexity, much of the game's more intricate mechanics are calculated by the game itself rather than the players. This allows for less of a cognitive load on the players.

2.2 Comparables

Terraforming Mars, seen in Figure 3 (Artefacts Studio & Twin Sails Studios, 2018), was our number one comparable and reference when designing *Purradise City*. We wanted to create a similar style of game where 2-4 players work together to build a colony - or in our case a city - and whichever player contributes the most wins. One of the largest diversions from the *Terraforming Mars* formula was the concept of collaboration. In *Purradise City*, placing buildings helps all players, since they are all working together to build the city. While the overall goal of our game is still to be the winning player, we also wanted to foster a feeling of collaboration. During the preliminary design phase, the team played a game of *Terraforming Mars* and discovered they greatly enjoyed the game but found areas of it highly complex. We wanted to borrow the core gameplay of limited action-based turns and use of cards, but greatly simplify it for *Purradise City*.



Figure 3 - The game screen of *Terraforming Mars*

Sid Meier's *Civilization* (2010) game series served as a secondary comparable for *Purradise City*. While overall, our game does not greatly resemble any of the *Civilization* games, we did discuss many features reminiscent of them. We wanted to have a high level of player interaction such as trade and discussion windows, and also liked the idea of building up an area and seeing it grow over time as the player improves the quality of life for the citizens. However, neither of these features ended up being implemented as we chose to focus on creating core gameplay rather than extra features.

Similarly, as with *Civilization*, we wanted to foster better player interaction than that of *Terraforming Mars*. For this, we turned to the highly successful board game *Settlers of Catan* (Klaus Teuber and Kosmos, 1995). *Catan* similarly features players controlling tiles on a board to develop an area, but unlike *Terraforming Mars*, allows for player communication and trading. As discussed previously, trading was never implemented, since it was too far outside of our final scope.

2.3 Premise

Purradise City began as an artistic concept, and we wanted to focus on the theme and presentation of the game just as strongly as the mechanics. We ended up putting nearly as much work into the visual and thematic design of the game as we did into the mechanics.

2.3.1 Theming

As previously mentioned, the original concept for *Purradise City* was that of a dating sim. A dating sim is defined as a type of simulation video game that revolves around the development of relationships with the in-game characters, commonly associated with dialogue-heavy games such as visual novels. Dating sims originated in Japan and are usually associated with varied anime art styles and tropes (Riva, 2015). When designing the aesthetic of *Purradise City*, our art team mainly referenced three games. These games were Date Nighto's *Hustle Cat* (2016), Cheritz's *Dandelion Wishes Brought to You* (2012), and Mediatonic's *Hatoful Boyfriend* (2014). Our reason for choosing each game is slightly different, however, one theme that ties the three together is that they are all furry-related in some way. *Hustle Cat*, as seen below in Figure 4, takes place in a cat cafe where all of the employees are also the cats (Date Nighto, 2016). *Dandelion* features a cast of nekomimi characters, both catboys and bunnyboys. *Hatoful Boyfriend's* characters are all represented by photographs of real birds, although you can view the artistic representation of each character in the game's extras.

Hatoful Boyfriend and *Dandelion* are also both categorized as "otome" games. Otome is a Japanese word that literally translates to "maiden" - and otome games are plot-based games marketed towards women, often in the form of visual novels or dating sims (You, 2017). Some otome games like the two we referenced have a cute and pastel vibe, and although this is not true of all otome games, we liked this type of aesthetic enough to prominently feature it in the theme of *Purradise City*, with our pastel color scheme and cute user interface and sound design. *Hustle Cat* is different, however, being a western dating sim and not considered an otome game. Instead, *Hustle Cat* is an entry in the growing field of LGBTQ+-oriented visual novels. Dating sim-type games have become more popular among the LGBTQ+ gaming community due to allowing players to experience complex narratives surrounding non-heteronormative relationships in a safe space (Rogers, 2021). While we were interested in creating a game that was aesthetically linked to the otome genre, we also recognize that these games tend to be highly heteronormative, and since our team consists of multiple LGBTQ+ individuals, we wanted to make our game more accessible to this community. As such, we designed our characters to be from a large selection of backgrounds, genders, and appearances, so that even if the players ultimately couldn't form relationships with our characters, they could still relate to and become attached to them.



Figure 4 - The characters of *Hustle Cat*.

2.3.2 Factions

We wanted *Purradise City* to have a place for player personality to show through. We thought a great way to accomplish this would be allowing players to choose what character they wanted to play and have representing them. After we settled on the idea of a collaborative board game, we decided to really hone in on the idea of building up a city. Since one of our main gameplay inspirations was *Terraforming Mars*, we decided to work off of their "faction" concept, in which each player chooses a faction to represent them. The factions provide gameplay bonus effects but also add flavor to the game with what they represent. We decided to create one character to represent each faction, for a total of sixteen unique characters. These factions were based on factions you may commonly see in a developing city, such as corporations, political figures, celebrities, or even the mafia. Each character was designed in such a way to reflect their faction and be easily recognizable.

2.3.3 Use of textual cat puns

At its core, *Purradise City* is a humorous game about cat people in a cat people world. We wanted to evoke this feeling that, while it may resemble the human world, *Purradise City* is really set in an alternate cat dimension. To do this, we used a large number of cat puns in our textual information. The majority of features, cards, and buildings are named using puns that we

hope will make players laugh. The use of puns throughout the game was something we decided upon very early in the design and helped inform our artistic decisions later down the line.

A great example of our use of cat puns is the way we refer to generations. Since *Purradise City* takes place over the span of multiple years, we wanted to find a way to differentiate these years into chunks. We eventually came up with the pun "Time Purriod", a play on "time period", as a way to refer to the generations of time. This and the original pun - "Purradise City" - helped inform our textual jokes within the rest of the mechanics.

2.4 Mechanics

There were five major mechanics that we settled on for the final design of *Purradise City*. All of these mechanics work together to create a cohesive game with complex layers.

2.4.1 Core gameplay loop

Purradise City follows a deceptively simple core gameplay loop that is defined in Figure 5. In essence, this is what occurs during regular gameplay:

1. Game setup - all players chose the faction they wish to play as. Resources are distributed to players based on their faction's stats.
2. All players gain income based on their money generation
 - a. Players gain or lose resources equal to the amount of resource generation they have.
 - b. Players draw 5 cards.
3. Each player rotates taking turns where they:
 - a. Perform up to 3 actions from
 - i. Playing cards
 - ii. Using core actions
 - iii. Activating special actions
 - b. Pass the turn, at which point they are skipped in the turn order until they reach Step 3.
4. Advance the Time Purriod
 - a. If this is the 9th time reaching this step, go to Step 4
 - b. Otherwise go to Step 1
5. Score Game

The player who has the most Voting Points (VP) at the end of the game wins. This is tallied by combining the total Population, Morale, Culture, and Wealth they contributed to the game via using cards and placing buildings.

Core Loop

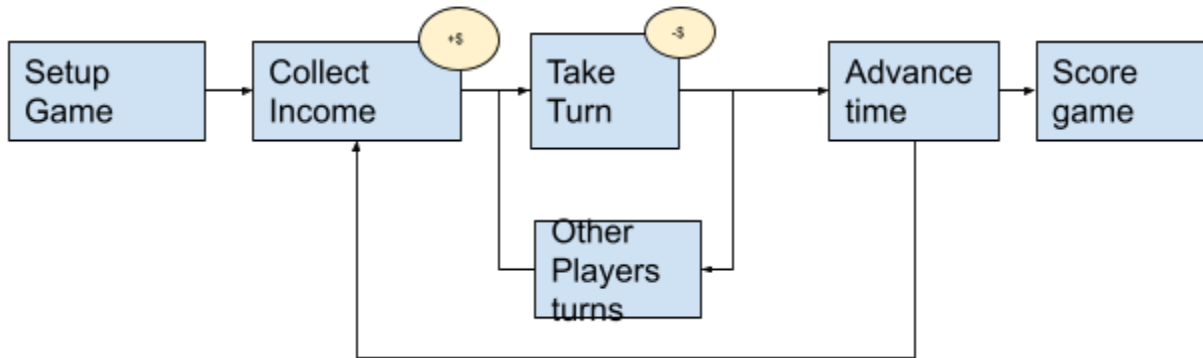

Figure 5 - The core gameplay loop of *Purradise City*.

2.4.2 Resource management

There are five resources: money, material, labor, public relations (PR), and suspicion. There are two stats tracked for each resource: the player's current amount, and the player's current generation. The current amount is how much a player has of a resource at that moment, and they cannot have less than zero of any resource or fractions of a resource. Current generation is how much of the resource you get at the beginning of each Time Purriod. This number also cannot be less than zero, except for suspicion, and cannot be a fraction.

Money is the general currency in the game. Everything costs money, and money is always usable. Material discounts building cards, PR discounts event cards, and labor discounts core actions. When playing a card or core action, you can choose to spend the associated resource for the card, and for each resource you spend, the money cost is reduced by two, but not to less than zero.

Suspicion works differently than the other resources. Some cards have the “Underbelly” tag on them. These cards will usually give suspicion. For every point of suspicion a player has, they remove one voting point at the end of the game. Underbelly cards tend to be more powerful and cheaper than most other cards in order to compensate for the increase in suspicion. Suspicion can be reduced through event cards or through natural generation. Most factions start with no suspicion generation - and unlike other resources, you can have negative suspicion generation.

That means at the beginning of each Time Purriod, players lose some of their suspicion. A player still cannot have a negative number of suspicion, however, so negative suspicion generation is wasted if they are already at zero.

2.4.3 Tags

Each building and event card has one super tag and one or two subtags. These tags help players identify what kind of card this is and what it will likely affect. These tags include things such as government, underbelly, corporate, education, food, and other city-related concepts. Additionally, there are many event cards that give bonuses based on what tags have been placed on the map or reduce the cost of buildings with specific tags.

2.4.4 Zoning laws

To create a level of depth in the building placement system, we decided to utilize zoning laws in order to incentivize thoughtful city planning. These zones are indicated through borders around selections of tiles. Buildings that are placed into zones can either have their cost increased, decreased, or unaffected based on the buildings tags. There are eight unique zones that each have two preferred tags, whose costs are reduced when placed in that zone, and two unfavored tags, whose costs are increased when placed in that zone.

2.4.5 Factions

Purradise City features sixteen unique factions split into four faction types. The four supertypes are based on the four resources, and the factions each gain an increase in their resources generation based on the supertype of their faction. They also gain one unique action based on their supertype, such as reducing the cost of the next played card at the cost of an action. Each of the individual factions also has a small bonus based on the faction's flavor. These include things such as the healthcare faction having a reduction in the cost of medical tag cards, or the cult faction gaining resources whenever an occult tag card is played.

Chapter 3: Technical Implementation

3.1 Software/Engine

Throughout the project, we used Unity 2021.3.11f1, as it was the most recent stable version at the time of the project's start. Overall, we felt this was the right decision as all of us were familiar with Unity to varying degrees, and by the end of the project we were all much more comfortable with the program. Although we debated using Unreal for the project at the start, we ultimately decided against it due to the software requiring more intense hardware than some team members owned, and general unfamiliarity with the software. In the end, the only real problem we had with the version we chose was that a particular plugin for tween animations that one of the programmers was most familiar with did not work on our project's particular Unity version.

3.2 Version control

In order to ensure proper version control management, we used GitHub extensively throughout this project. Both members of our programming team were well-versed with the software and thus encountered little to no problems using it. In addition, a tutorial for GitHub Desktop was made for the art team members, both to make sure they knew how to use it in case something was required of them and to give them the ability to observe GitHub use in a scenario where there were no stakes for them.

3.3 Game class structures

As *Purrradise City* is a digital board game, the vast majority of code had to be written from scratch since Unity does not have existing structures for digital board games. Thus the class structures and process managers had to all be built carefully so that all elements of the game could communicate with each other well while balancing early functionality with the flexibility to expand and implement the rest of the initial vision. The structure of the game code can be broken into these subsystems: the action system, the player system, and the management system.

3.3.1 The action system

The action system is the part of the game that makes it so that something happens when a player plays one of their cards, core actions, or player actions. The core of this System is the "Card" class. This class stores all the details of each card, such that they can be displayed,

tracked, moved, and activated, letting the game work. Each card has an “Action” object within them, a special structure set up specifically to communicate the exact effect the card has. By using pairs of matched arrays, an action object was creatable for any combination or number of effects possible at the same time. One array tracks what type of effects are used, while the other array acts as an input to the effect. For example, an action represented by {3, 16} & {3, -1} would translate to "increase population by 3, reduce money generation by 1". Action #3 is defined as “increase population” with an input of 3, and action #16 is defined as “alter money generation” with an input of -1.

Once we had a way to represent the cards and what they did, we needed to track where they were and display them to the player. Here is where the "Pile" classes come into play. Several different classes inherit from Pile, all of which are data structures to place and track cards. A few examples are the "GameDeck" which can be shuffled and drawn from and the "PlayerDeck" which is a container for the player's hand and discard pile. This allows them to be displayed and creates Unity GameObjects for the cards, letting the player see and click upon the cards.

3.3.2 The player system

The player system of classes is a suite of classes designed to handle the individual setup for the game and to track information that is unique to each player. The primary class for this is the "Player" class. Each instance created contains all of the data needed to track the resources, points, activities, and graphics for any particular player. This class works with the "Faction" classes, which are pre-built data classes that contain the starting resources, sprites, and special powers that each player begins the game with. Right after the faction selection screen inside the game, these player objects are made and initialized in accordance with their chosen faction. The player system also handles each player's resources, tracking how much they have, what discount affects the player has active, how much the player will make each Time Purriod, and figuring out if a player can afford to activate any given effect.

3.3.3 The management system

While the action and player systems are set up to be instantiated and track localized details, the management system is a collection of classes that are either static or have exactly one instance inside of the scene. These classes are placed inside an invisible script object, so they are not visible to the players. They have all of the methods that make sure effects communicate and that the gameplay loop of the game runs the proper course. The largest of these is the

"GameManager" class, which enforces turn order, takes actions, updates the HUD, and every other aspect needed to ensure the flow of gameplay can continue unhindered. Smaller managers exist for almost every structure within the game, such as the "CardDatabase" and "BuildingDatabase" classes that store the cards and sprites before the game places them in the player's hands or on the map of the city. There is also the "FactionManager", which applies the instructions within a faction to instantiate each player.

There are screen manager classes that handle things like the "BuildingGrid", a set of tile maps that create the layout of Purradise City's landscape and place the building on the screen. Or "ToolTipSystem", which tracks and controls the tooltips across the screen. The "CanvasController" and "WorldManager" classes wrangle the many screens and menus needed to run the game, making sure the player only sees what is needed and can only interact with the active menu. This myriad of classes overreaches the game, handling all of the communication required under the hood to make a playable and intuitive game for the user to experience.

3.4. Flow of the game

Purradise City begins with a title screen. On this screen, players can adjust the various settings, or jump right into the game. Once a game is started, players are presented with the faction select screen, allowing them to select which faction they would like to play as. Players pick in the same order that their turns will occur, and no faction can be selected by more than one player. Once the factions have been selected, the players are initiated behind the screen and are then presented with the game screen.

At this point, the normal gameplay loop begins. GameManager starts the first turn with player one. If a player selects a card, core action, or special action, GameManager first checks if it is a building or not. If it is a building, the tilemap is enabled, allowing the player to select a location on the map for the building. This is also where the district discount or upcharge is applied. After this is determined, GameManager checks with the player's class if they can afford to complete the action. If they cannot, it returns to the default state, providing the player with a popup informing them that they cannot complete the action. If they can afford it, a menu is drawn that allows the player to select if they wish to pay with money, another resource, or a combination of both. Once the player pays, the effect of the card or action is activated.

This system repeats until the player has selected "End Turn". The player can then select whether or not they would like to pass their next turns or continue playing the next time it is their

turn. Gameplay is then passed to the next player, and their faction information is drawn. Once all players have decided to pass, the Time Purriod tick screen appears, changing the Time Purriod of the game, and activating any Time Purriod-based effects such as resource generation and card draw.

Once the last Time Purriod is reached, the GameManager calls a special system instead of the normal one. This gives each player exactly one turn before the game ends. Once each player has taken their final turn, the endgame screen is displayed, and VP is tallied. The player with the most VP is displayed as the winner of the game.

3.5 User interface

As there was a great deal of information to convey to the player, making sure said information did not clutter the screen was of great importance to us. Due to our already established goal of keeping the game looking cute and fun to interact with, having a whole bunch of text all at once on the screen challenged this idea and proved a problem for us to work around. As a result, several techniques of organization had to be employed.

One of the main ways we kept things decluttered was by separating things into groups as much as possible. Each individual screen state had its own separate canvas, which made editing these groups and their individual parts much easier to deal with. In addition to this, each moving part also had its own canvas group. These canvas groups were then initialized using the DoTween plugin, a free and commonly used plugin for Unity that makes a lot of screen transitions far easier to integrate. By having smoother transitions and neatly organized groups, the UI quickly turned from a list of overwhelming values to easy-to-comprehend information.

That being said, there still was information that we wanted to convey about what exactly to do with all the facts that were now neatly showcased on the screen. While we implemented the tutorial system, we felt this was not enough and instead decided to create a tooltip system. Now, after hovering over a single item for a short amount of time, a little factoid explaining to the player exactly what they are looking at would appear. This was non-invasive and served as an essentially limitless source of extra information padding we could throw onto objects should the player be confused about them.

3.6 Milestones

Due to the fact that we had a very specific time frame during which this project was to take place, as well as the academic nature of this project continuing over the course of a school year as part of the larger WPI program, we found we both needed to plan our time rather precisely and meet a variety of milestones throughout the year. These milestones took on a variety of forms, some pertaining to all projects in our major, and others coming as a result of following a standard game development cycle.

3.6.1 ProtoFest

Our first milestone came early on in the school year in the form of Protofest. For this event, we did not yet have a digital build of *Purradise City*. Instead, we decided to present the paper prototype we had been working with up until that point. Our goal for this playtest was strictly to test the design of the mechanics of the game. This allowed us to discover what features worked well, and what ones we could do without. We did not have a very strong roadmap for this term, which caused us to be behind for a while since we did not focus on the digital build of our game for so long. However, we were grateful we decided to present the paper version first, as we were able to use the feedback to decide upon the most important features to implement in the build first.

3.6.2 AlphaFest

For our next milestone, AlphaFest, we wanted a version of the game that was on a computer - and we had less than two weeks to make this from scratch. This was our most difficult term in terms of meeting our proposed goal. Since AlphaFest was so quickly upon us, we had to race to create the digital build on time. The roadmap for B-term had to be shifted back many times as we learned how difficult it was to implement the features we wanted for the first playtest. We were able to present the first build of the game, however it was extremely barebones. Because of this, most of the playtesting feedback we received had to do with what was missing from the game. While we were impressed with what we were able to accomplish in only two weeks, we still had a long way to go before meeting the goals of our next build.

3.6.3 Vertical slice

Our vertical slice deadline got pushed back quite a bit due to a variety of situations, including, but not limited to: a team member's apartment catching fire, a team member's

computer completely breaking apart, and a variety of other unforeseen and sudden circumstances. In the end, we were able to drastically improve upon our previous build by the end of C-term, only a few weeks after our original goal for the vertical slice. The art team was even able to exceed their end-of-term goal by completing a pass of art for every card. However, tech fell behind as they began to work on more and more complex features. Our only playtest for this milestone was the advisor playtest, which we used as a way to measure our progress and figure out the most major issues that needed to be fixed. It was very close, but we did meet our goal, and prepared to work hard to get the game to a complete state during the next term.

3.6.4 Beta

Our Beta build of the game came together part-way through D-Term, where the vast majority, but not all of, the core systems were functional and implemented in the game in some way or another. We also completed all the art assets halfway through the term, making the implementation of art into the game easier than ever. Our roadmap for this term was left bare on purpose - we weren't sure what we were going to struggle with. We built it up as we went through the term. During this term, we were able to present a Beta of *Purradise City* to a few playtesters. Interestingly enough, almost all of the feedback from this test was either about bugs, or features that simply had not yet been implemented. This helped us to devise a plan for what we were going to work on first in order to have a proper game to show at ShowFest.

Chapter 4: Art

4.1 Concepts

As mentioned previously, the main inspiration for *Purradise City* artistically was the dating sim genre of games. We referenced our aesthetic style from the same three games mentioned in the previous theming section, *Hustle Cat*, *Dandelion Wishes Brought to You*, and *Hatoful Boyfriend*. All three games have their own unique art styles and aesthetics, but overall they share the cute vibes of an otome game. For our characters, however, we specifically wanted to avoid the homogeneous character designs seen in *Hatoful* or *Dandelion*, seen below in Figure 6 (Cheritz, 2012) and took more inspiration from *Hustle Cat's* diverse cast of characters. Combining these styles together allowed us to create a unique look and feel for *Purradise City*.



Figure 6 - Characters from *Dandelion Wishes Brought to You*.

4.2 Color palettes

Based on our reference material, we decided to use a pastel color scheme for *Purradise City*. Pastel refers to "pale and soft [colors]" (Cambridge Dictionary). We use a pastel palette to evoke a positive and calming feeling while playing the game. Pastel colors "evoke a sense of calmness and balance". Because of their low saturation, they appear delicate and mellow. According to color psychology, these shades sometimes even equate with sanity. Pastel colors, more than any other color palette, suggest romance and tenderness (Braam, 2021). After numerous color demos, we decided on a scheme featuring four main colors. These colors were

the pastel versions of pink, purple, yellow, and blue. Other colors were used in conjunction with these four, but the four colors informed our decisions on major artistic features of the game such as the logo. In order to maintain the pastel theme, two colors had to be moderately avoided, these two being red and green. Any time red was used it was diluted towards pink, and green had to be either tinted yellow or blue to avoid eye strain. While avoiding red and green does help create a more color-blind friendly game, we were aware of other issues that may result from other color pairs such as blue and purple. To this end, we decided that UI features would all have unique shapes in order to aid in identification beyond just through the colors.

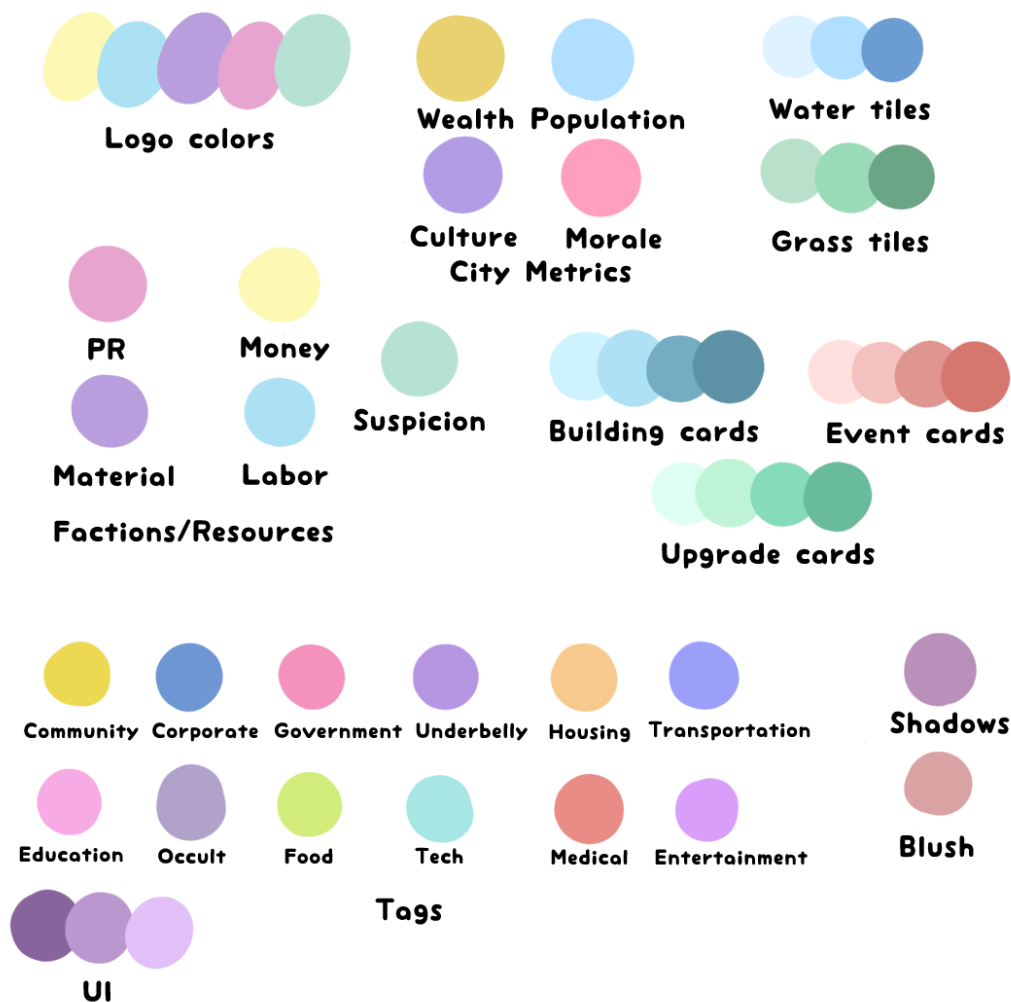

Figure 7 - *Purradise City's* color guide.

4.3 Character art

In order to get a feeling for the whole game's art style, we began by defining the style we wanted to use for the characters. We wanted something that carried a lot of the feelings typically found in the style of "shoujo anime" - literally meaning "girl anime" - without explicitly being an anime game. The original characters went through many sketches before the style was fully settled on. In the end, we decided to focus on characters with semi-realistic proportions, but stylized details. Characters have simplified faces with large, expressive eyes, but their bodies are less exaggerated. We kept the characters' colors realistic as well - while some may have dyed their hair, the cat features reflect real-world cat colors and patterns. It was important to the art team to be able to create a diverse range of body types, skin tones, and features to have an easily recognizable cast that appeals to many types of people. Clothing was kept fairly simple - characters were dressed based on their faction, but for the most part in solid colors or simple patterns. After some testing, we decided to use a painted style of shading to help soften the portraits and create a wholly unique art style.



Figure 8 - The cult faction of *Purradise City*.

It was important for us to continue the color palette into the characters. In the early stages, we assigned each faction group one of the three main colors of the game - pink for the public relations factions, blue for the labor factions, purple for the material factions, and yellow

for the money factions. Each of these four groups contains four factions. When designing the factions, we made sure to incorporate some form of the faction's assigned color into the character's design, generally in their clothing. This is to help players learn to associate the colors with the resources that the factions are associated with and keep consistency throughout the game.

Creating the characters for *Purradise City* was a process that spanned multiple months. We started by sketching a few preliminary character designs and working with these in a digital format to explore styles of linework and color. After we came to a conclusion on the art style, our character artist sketched out sixteen designs based on the chosen factions. Each of these designs went through multiple sketch iterations to really solidify the designs. Then, we digitized the sketches and inked over them, tweaking the designs and poses along the way. Characters were given flat colors based on the color palette defined earlier. Lastly, the shadows and highlights were painted on to provide depth and interest to the character portraits.



Figure 9 - A lineup of *Purradise City* characters. From left to right: the music faction, the mercenary faction, the mafia faction, and the church faction.

4.4 Environment art

For *Purradise City*'s map, we wanted to give it a pixelated look. The goal was to make the player feel like they are looking at a digital overview of the city. The map itself was divided into hexagonal-shaped tiles to simplify the placement of buildings.

4.4.1 Tiles and borders

Tiles come in two different varieties: grass tiles and water tiles. Grass tiles represent land that can be built on. There are variations on the grass tiles in order to make it so the game map does not become a repeating pattern. The same is true for the water tiles. Water tiles represent spaces where there cannot be buildings built unless a building card specifically states otherwise.

Each tile has a 2-pixel thick border around it. These borders are color-coded in order to signify different aspects of the tile they surround. Grass tiles normally have a dark green border, and water tiles normally have a darker blue border. However, there are other border colors used to indicate different zones in the city. Yellow borders indicate community zone tiles, blue borders indicate corporate zone tiles, pink borders indicate government zone tiles and purple borders indicate underbelly zone tiles. There was a long process of figuring out the right amount and ratio of pixels needed in order to create the shape we wanted and to make the borders tile properly. Several versions were proposed and tested until we found what worked.

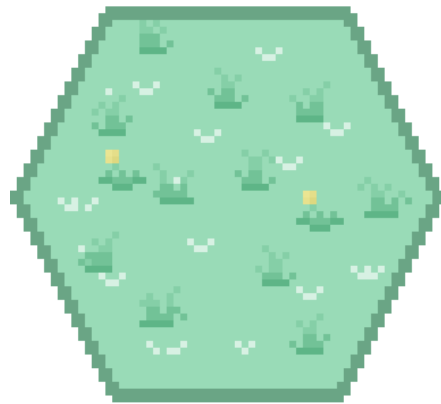

Figure 10 - *Purradise City* grass tile.

4.4.2 Buildings

Buildings were designed to resemble cat trees and cat towers. Other cat-like aspects were worked into building designs as well, such as cat ears and parts of buildings taking on a cat-like shape. Care was also taken to incorporate details distinct to the type of building being designed, so they could easily communicate what they are to players. After a brief conception phase, building sprite creation commenced. The creation process for each building sprite can be divided into 4 basic sections: creating the base structure, filling in the base colors, adding windows, and then adding any additional details. The base structure of each building was constructed by fitting

together different-sized “blocks” that were made by a member of the art team before the creation of the buildings themselves began. This allowed the base for buildings to be made quickly and efficiently. It also allowed building sprites to remain relatively consistent.

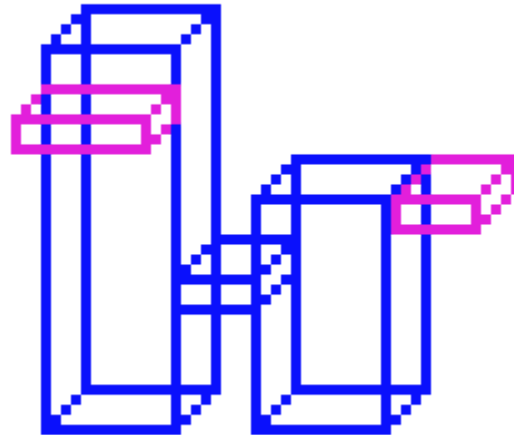

Figure 11 - *Purradise City* building blocks.

Once the blocks were placed, edits to the pre-existing blocks and proportions were made and any additional base structure components were drawn in. Then, base colors were added to the buildings. The base color of each building was determined by what tags were associated with that building. Each tag had a color used to represent it, and this was used to determine each building's base color as well. After the color came windows. Windows were an important addition when it came to really selling the “cat-tower” look we were trying to achieve. Each window was the same color across all building sprites, with a slightly darker color serving as a shading line on their left side to give the illusion of depth. The final step was to add any additional details. Some buildings needed a little extra to sell what they were, whether that be a sign for a restaurant or a plane for an airport. Buildings were then reviewed by the team and adjustments were made to fix anything that needed improvement.



Figure 12 - A selection of *Purradise City* buildings. From left to right: the nightclub, the space station, the cathedral, and the meownsion.

4.5 User interface

A major inspiration for our UI was *Terraforming Mars*. However, *Terraforming Mars* treads the line of giving the user ‘information overload’. *Purradise City* does not require nearly as much information to be present to the player at all times, and as a result, we did not need to worry about the problems that *Terraforming Mars* faced. This was greatly assisted by our implementation of hover tooltips that allowed us to have a simplified user interface.



Figure 13 - *Purradise City*'s user interface and game screen.

For our user interface, we wanted to create something that kept the fun and lighthearted tone of the game. We also wanted the user interface to reflect our pastel color scheme. The user interface began in greyscale. Before adding color, we blocked out a mock-up of what we

envisioned the main game screen UI to look like. We then refined this mock-up until we were happy with it. We repeated this process with the other UI screens in the game, including the different dialogue windows and menus. Once everything was blocked out, different color combinations were tested. We went through many different color combinations before eventually settling on the purple color scheme that is seen in the game.

Once we knew what the user interface was going to look like, we had to implement it. The many different buttons and borders in the mock-ups were separated into individual assets. They were then shaded and polished. Once that was done, they were each individually implemented into the game.

4.6 Cards

Cards are a very important mechanic to *Purradise City*. There are over 100 unique cards featured in the game. It was important for us to make these cards both readable and nice to look at.

4.6.1 Card UI

Another major component of *Purradise City* is the cards. Cards are a core piece of the gameplay, and it was incredibly important for the cards to be clear and readable to reduce player confusion.

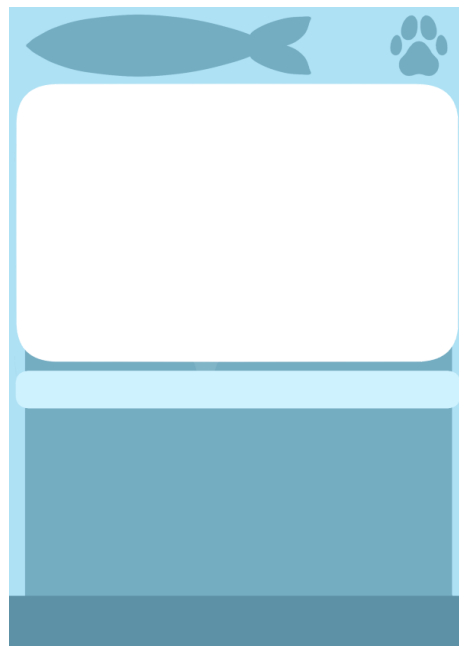

Figure 14 - The layout of cards in *Purradise City*.

Each card has several different features, each providing information to players that lets them plan and develop their strategies. Card features include the cost, tags, and effect descriptions. In addition to practical elements, they also have flavor embellishments such as creative cat-pun names and key art.

There are two types of cards in *Purradise City*.

1. Event cards are cards that when played activate some kind of effect or “event” that can help or hinder players. These cards use red as their main color.
2. Building cards, when played, place the building pictured on the card onto the game map. Buildings also create different kinds of effects when placed. These cards use blue as their main color.

The card layout was developed similarly to the user interface. The cards were initially blocked out in grayscale, and the overall layout and look of the different boxes on the cards were tweaked before a final design was settled on. Then, the colors were added to the cards.

During the layout phase, the box for the card name and the box containing the cost of the card was just a rectangle and a circle respectively. We decided while refining the layout that making the card name box fish-shaped and the card cost circle paw-shaped better fit the theme of the game better. Figure 13 shows what the final layout of the cards looks like.

4.6.2 Card art

With over 100 cards to get through, we needed to devise a style that would be easy to replicate for each card and simple enough to reduce the time spent on each card to an average of one hour. One way we accomplished this was to use the build in separation between event and building cards. Building cards used the building sprites previously created for the game's map, reducing the number of card illustrations needed by around half. For the event cards, we landed on a simple painting style. This decision allowed us to create many cards and avoid visually overwhelming graphics. We focused on using round shapes with soft edges, shadows, and highlights. No hard lines were used for any of the cards to keep consistency. Characters and objects that appear in the card's illustration were highly simplified, leading to the simple anthropomorphic cat designs that feature in many of the game's cards. Each card's illustration was based mainly on the card's pre-determined title rather than its effect.



Figure 15 - Two *Purradise City* cards, Nekomancy and Catnap.

As the cards needed to be created quickly, they went through a much shorter review process than the characters did. Two cards were created early on in development as style tests and placeholders for the alpha version of the game. Using feedback on these tests, we improved upon the style of the cards. Cards were thumbnailed all at once, and then reviewed before moving into painting. The first pass of card paintings was completed very quickly in order to have a large selection of cards to work with when implementing into the game, and to have a fallback should we run out of time to continue working on cards. Then, these preliminary cards were reviewed extensively and improved upon in multiple passes for visual interest and clarity.

4.7 Logos and Icons

Purradise City makes heavy use of icons to provide a visual reference for mechanical information. We decided that it would be advantageous for our game's UI to give visual information rather than textual information in order to not overwhelm the players. This also doubled as a way for us to include more cat-theming in the interface.

4.7.1 Game logo

Purradise City's logos were the first pieces of art completed for the game. We used the logo as a way to define the overall feeling and color of the game and also used it to create the color palette that we later used for all art assets. Originally, the logo was created with flat colors and shading, but we decided to use the same painting style as the factions in order to better tie it into the game. The logo went through multiple iterations - we started with four unique designs and ended up liking two of them enough to use both for different instances - one as a main logo, and one as an icon. We also started with four color schemes but eventually settled on the one that

is seen throughout the entire game. Creating and finalizing the logo early on in design allowed us to use it as a reference to base all future assets on.



Figure 16 - *Purradise City's* two logos.

4.7.2 In-game resources

Early in development, we decided to use images to represent the game's main five resources. Four of these resources are associated with the factions, and as such use the same colors. But the fifth resource - suspicion - was special and required a new color, which ended up being a pale teal that felt distinct enough from the other colors to stand out. The icons use a painting style similar to the game's logos. They are very simple and rounded with soft shadows and highlights. Their colors are slightly brighter than those of the game logo in order to better stand out against the user interface. Each resource is a cat version of the resource it represents - a coin featuring a cat's face represents money, a ball of yarn is material, a raised paw for labor, a small bell for public relations, and a fish for suspicion.



Figure 17 - *Purradise City's* five resources. From left to right: money, material, labor, public relations, and suspicion.

4.7.3 Tags

In *Purradise City*, each card is sorted into one or multiple tags that help define what the card does. To reduce text clutter on the cards, we decided to have icons represent the tags. We once again used the four main colors for the four major tags - blue for corporate, pink for government, purple for underbelly, and yellow for community. Each super tag has two secondary tags that use colors branched off of the main colors. The tag icons are painted in the same fashion as the resource icons and continue the cute cat theming.



Figure 18 - Examples of *Purradise City* tag icons. From left to right: food, occult, underbelly, education, and corporate.

4.7.4 City metrics

Near the end of user interface development, we decided the UI would look more consistent if the city metrics had representational icons as well. Since the resources and tags already had icons, it only made sense to create some for the city metrics as well. We assigned each metric a main color - blue for population, pink for morale, yellow for money, and purple for culture, but we used different shades to differentiate them from the resources. These icons are in the same style as the previous icons, and once again are themed after cats.



Figure 19 - The city metric icons in *Purradise City*. From left to right: wealth, population, culture, and morale.

4.7.5 Use of visual cat puns

As mentioned throughout this section, we wanted to keep a sense of humor and cohesion throughout the game with visual cat puns. This includes things such as cat-themed objects like

fish and balls of yarn, or cat-themed architecture based on cat trees and other toys. This ties into our use of textual cat puns and helps create the sense that this world is truly inhabited by cat people rather than humans. For example, in Figure nineteen, the card "Fishy Deals" depicts two cats dealing in fish. It also provided a fun challenge for the artists to create appealing visuals with a tight theme.

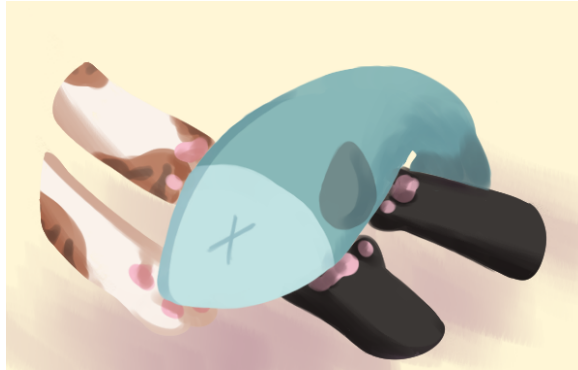

Figure 20 - The *Purradise City* card Fishy Deals.

Chapter 5: Sound Design

For both sound effects and music, we ended up sourcing almost all of our material from DOVA-SYNDROME (2008), a database of commercially free-to-use music and sound effects specifically created for streamers, filmmakers, and game designers. This proved to be an invaluable resource, as although some of us on the team had experience with working with audio beforehand, we were not well-versed in the art of audio work for game design specifically, nor in musical composition. DOVA-SYNDROME hosts a wide array of frequently updating sound effects and BGM with an extensive tagging system, allowing us to hone in on the very specific sort of bubbly feeling we wanted for the game.

For sound effects, we wanted to reflect a pop aesthetic. The color palette and general aesthetic of *Purradise City* features a lot of bright pinks and rounded corners, giving the game a fun look. With this in mind, we did not want to have the button sound effect be too jarring. We settled on variations of bubbly and popping noises for more major buttons, such as starting the game or clicking a major tab, and then dulled the noises down a bit for other more common button presses, such as a card selection, in order to not make the noise grow annoying.

We wanted to continue the pop theme into *Purradise City's* music without overwhelming the player. When searching for music tracks to use, we listened for music that felt bright and fun, but not overwhelming. Our game is fairly long, and players will be listening to the music for extended periods of time, so we wanted to use tracks that would not become grating or annoying over time. We also wanted the music to be a bit calmer than the sound effects so players can feel relaxed while building their city.

Chapter 6: Playtesting & Showcasing

6.1 Reactions

Our focus during the course of playtesting was to see and evaluate the reactions of the playtesters. In the early stages of testing, we were able to run multiple playthroughs of the game with our project team, and we all decidedly had fun playing it. We ran a full game session with non-team member testers and they all agreed they had fun playing the game. When we started the digital build of the game, it became less about getting a feel for how fun the game was, and more about if it was playable at all. Our first build struggled with barebones UI and very little gameplay and most of the feedback we received revolved around players wanting a better UI and more features - things we were already planning on implementing. This was also the first time we had digital art assets, and most playtesters commented that while they liked the art, they felt it lacked cohesion. As we continued to playtest *Purradise City*, testers greatly enjoyed the final art style and complete user interface but continued to discover bugs and unimplemented features. Every time we playtested the game, we discovered, through the testers, new issues and glaring missing features that helped us create a plan for each revision of the game.

6.2 Takeaways

For the art team, our biggest takeaway during playtesting phases is that while most people enjoyed the individual art assets, they felt they lacked cohesion. We used this feedback to define our color palette and the styles for each type of asset to keep them visually distinct but similar enough to make it feel like it all belonged in one game. As the art style evolved, players stopped commenting on the cohesion and genuinely found the art style appealing.

On the tech side, the majority of comments revolved around bugs and unimplemented features. We promised many features of the game during our initial playtests and it took us many builds to deliver on most of the features. Players would attempt to use actions or buildings that simply did not work yet, or worked incorrectly. We watched the players test the game directly in order to record any bugs they discovered as well as figure out what the most requested features were. Players wanted to be able to perform all the promised actions and complete more than one turn of the game. One of the most requested features that were not implemented until nearly the end of the production was the individual building appearances - proving that the aesthetics were

one of the most important aspects of the game to the testers. Every time a tester discovered a missing feature, we worked hard to get it into the game for the next round of testing.

6.3 Applying feedback to the game

After each playtesting session, we would debrief what we learned. We used surveys to collect information from players, but we found that watching and taking notes while individuals tested the game was more beneficial. This allowed us to note down bugs we noticed, or comments given about the visual design of the game.

The ProtoFest playtesting session was all about design. It was from this particular playtest that we made most of our design changes. Originally, *Purradise City* was meant to have three actions per turn. But after seeing how the session of the game ran for nearly two hours without completing, we decided we needed to make moves to shorten the game. Thus, we reduced the number of actions to two, quickening the speed of the turns. One of the most important things we discovered during this session was that the game needed to be digital. There had been ideas going around about keeping it as a physical board game since the paper prototype was so successful. However, when watching other players play, we noticed that there were many moments of down time where the players had to apply features such as resource generation and deck additions by themselves. We decided that automating these in a digital space was going to be the best way to reduce the time spent playing a single round of the game.

AlphaFest and all tests afterwards brought with it numerous bugs discovered by the testers. A few of these bugs are ones we could not have discovered without watching new players mess with the game. We had players who noticed that, when paying for a building or event with either material or PR, they could trick the game into giving them free money. This is because, although we intended the cap of the cost reduction on cards to be 0, we had unintentionally allowed material/PR to discount the full 3 money cost even if the cost of the card was only 2, resulting in a cost of -1 money. We would likely not have noticed this error if players didn't mess around with the menus so much. We were able to fix this, thankfully, as it was a rather small error.

Another bug had to do with cards not disappearing from the player's hand. Since we didn't have any visuals for drawing or using cards at the time, this bug did not initially appear to be such to the playtesters. When playing certain cards, the card would not be used up, and would still be available to play on the next action and proceeding turns. Additionally, if other players

had less than five cards in their hand, these cards would appear in their hand as well. Players used this to gain the system as these cards cost 0 and gave 1 money, allowing them to generate infinite money. It was actually a member of the art team who realized the reason for this bug - the cards were free, and were not passing through the same system as cards that players had to pay for. We were able to fix this by forcing free cards to pass through the GetPaymentSystem, but skip the actual cost menu. If we did not have playtesters encounter this card and attempt to use its unintended feature to win the game, we would not have even known about this bug.

Quantifying the artistic feedback was more difficult than keeping track of found bugs and requested features. Overall, during most of our playtests, the testers appeared to be happy with the artistic design of the game. One of the biggest hurdles we had was, as mentioned before, the cohesion of the art style. This was also difficult to pinpoint, as most of the feedback we received was from people who were not trained in art and didn't have much to say beyond expressing their enjoyment of the art. However, after looking through survey data, we noticed that testers were generally more impressed with the character art and cards than the buildings. Therefore, we decided to work on improving the design of the buildings to fit better into the world. We tested using a painted style for them as well, but decided we didn't quite like it - instead we chose to add more detail and color cohesion to the buildings, which really helped to fit them in with the rest of the art.

Chapter 7: Post-Mortem and Conclusion

This section serves as the post-mortem for *Purradise City*. Here, we analyze the project and our process toward completion. We discuss what went right during development, what went wrong, and our thoughts on what we learned and how to improve moving forward.

7.1 What went wrong

Like any project, there were many conflicts that occurred during development. Here, we discuss a few of these issues and how they affected our progress, as well as how we worked to overcome them.

7.1.1 Little to no plan going into the project

Purradise City was pitched during the MQP pitching event in C term of 2022. The team and advisors were also decided around this time. At this point, all we knew was that we wanted to make a catboy city-building game. Beyond that, nothing else had been decided. The team discussed wanting to work on the game pre-A term, but as often happens during the summer months, nothing got done during that time. This meant that we went into the term with no plans other than the basic concept for the game, and had to spend the majority of the term making plans and design decisions.

7.1.2 Too much time spent in the design phase

We spent the entirety of A-term on design. Our reasoning for this was that, because we were doing a 4 term MQP, we had the extra time to really flesh out the design and mechanics of our game. While at the moment this felt like a good idea, and it certainly did help us create a really solid design plan, it meant that we had to work very quickly in the next term. Since AlphaFest was planned to be early in B-term, we had less than half a term to create a digital build of the game. It ended up being very barebones and was not a great showcase of our game's planned features. This extended design phase also meant we had less time for implementation overall, which led to a lot of scrambling to add features in the weeks before Project Presentation Day.

7.1.3 Lines of communication were fixed, but a little too late

When compared to previous group projects, our communication was actually very solid. There was, however, a large issue that cropped up during D term involving communication about Git builds. The tech members of our team were not communicating when builds were pushed or

merged in GitHub, which caused multiple instances of lost work due to merge conflicts. Once the tech team realized this, they started communicating their Git updates, which mostly fixed this issue.

7.1.4 Lack of cohesion in art styles

Our art team consisted of two people, which is more than most game design-focused projects. We wanted *Purrradise City* to have a large focus on the art, however, so this was to our advantage. However, after receiving feedback from AlphaFest, we realized that we needed to figure out how to make the styles of two different artists fit together in the same game. One of our artists was creating painted assets, and the other was doing sprite work. We decided that we did like this combination, but it took much deliberating and revision of styles to get the assets to all fit well together. This ended up setting back the art pipeline a bit as we had to largely revise all pieces made before this change.

7.1.5 Effects that do not translate well to a digital space

We decided early in development to create a "pass and play" multiplayer game, where players all play on the same system and use the honor system to determine who gets to play during each turn. This meant we did not have to implement any network systems or systems locking controllers based on turns. However, during the paper prototyping phase, we forgot to account for this and designed many features that would require decisions to be made by a player other than the active one. Once we began building the digital version, we realized this would be an issue and cause problems with comprehension of whose decision it was to make.

There were also a few cards that were designed to be unique and interesting during the paper prototype. However, these cards had to be re-designed to fit into the types of cards we could actually make for the digital game. These cards all had one-off effects that would require special menus and complex coding just to get one specific feature to work. We decided we would rather focus on polishing a larger selection of effects and scrapped these unique effects. There were also cards that were meant to "undo" the effects of a previous card. This ended up being too difficult to implement as well since it required the game state to track and manipulate very specific things that were easy to mess up.

Dynamic conditions and costs were another feature cut from the final due to being overly complicated. They required multiple extra one-time menus and were incredibly buggy. The two cards Scandal and Bribery are great examples of this, as Bribery was supposed to allow players

to pay a dynamic amount of money to remove suspicion, and Scandal was to be only playable if the player had 5 or more of both suspicion and PR. Overall, there were a lot of small features that were added to create an extra layer of interest in the game's prototype, but had to be cut or redesigned since they were difficult to translate to the digital version.

7.1.6 Hard to present at ShowFest

While discussing what could have been, we came upon the realization that the decision to make a multiplayer game was a large contributor to the difficulty of presenting our game. While we were overall happy with our final decision for a multiplayer game, we had to consider that if we had gone with the original dating sim idea, our game would have been much easier to present during the WPI presentation events like ShowFest. Our game requires four players to be huddled around the same computer sharing the same keyboard and mouse, which does not easily lend itself to drop-in playtesting and showcasing. We don't regret our decision to go multiplayer, but it would have made certain things easier to create a singleplayer game instead.

Additionally, *Purradise City* is a long form game with a high level of complexity and a steep learning curve. Since ShowFest and other presentation days tend to only run for one or two hours, playtesters and visitors usually spend only a few minutes at each booth. It can take quite some time to just learn how to play our game, so it can be a time sink for people who want to be able to look at all the games presented. This makes it more difficult to get people quickly interested in the game, and harder to retain a large amount of players.

7.1.7 Sometimes life has to come first

Life gets in the way of every project, but sometimes it felt like life was being particularly difficult during the course of this project. We had many large issues crop up such as laptop failures, house fires, and medical emergencies that caused many setbacks in production. Because these events occupied so much of our time, we had to re-scope and redesign portions of the game to make sure it got to a state of completion and polish we were happy with, even if it was not as grand as the original vision.

7.2 What went right

Even though we faced many challenges during development, there are some things that we decided to do that really helped us get our project to where we wanted it to be. We have documented a few of these choices and how they helped the team.

7.2.1 Solid design phase

Because the team spent so long in the design phase, we were able to use that time to really refine the design. The gameplay was able to go through plenty of different ideas and iterations to determine what worked and what did not. We had the extra time to find what gameplay features would fill in the gaps and what we did not need. The artwork also benefited greatly from this extended time spent in the design phase. Character designs were planned during this phase which allowed us to move into the final designs faster. The UI was also created in this phase, and is extremely similar to what is seen in the final game - all that it needed was polish. Getting these aspects planned and partially completed allowed us to focus on other more pressing areas of the game during the rest of development.

7.2.2 Clear communications about artistic vision

Although we previously discussed the disconnect between art styles, there was still a lot that went really well concerning the art. Since our two art team members knew each other very well and were easily able to communicate, we had a very strong artistic vision for the game. The original concept was pitched by the art members, and the tech members were added after we had decided to make a catboy themed game. We knew exactly what we wanted it to look like very early on in design, from the character designs, to the buildings, to the UI. Although there was still a lot of revision of styles and assets to be done, the final game looks very cohesive because we were so open about what we wanted it to look like.

7.2.3 Lots of playtests, lots of feedback

We had a total of five playtesting events that gave us a total of twenty-eight individual playtesters, not including team members and advisors. While we do not have anything to directly compare it to, we feel as if this is a really solid number of playtesters. Since the playtesting events were open to all IMGD MQPs, we were playtested by and playtested for other MQP members, creating a circle of feedback that allowed all the MQPs to get good, strong feedback. Every playtester gave us incredible feedback that directly helped inform the future of the project. Being open to feedback and attending all the designated playtesting events really helped us further refine our game.

7.2.4 Audio as an Afterthought

Being a team of two artists and two coders, we knew that audio was not going to be a large focus of this project. We did not even consider working on it until partway through the final term. We decided we were not going to have the time to dedicate to making our own audio, so we spent a few days collecting free-use audio sources. This allowed us to spend the rest of our time on other aspects of the project while still having audio to enhance the game.

7.2.5 Scrapping the story

Purradise City was originally intended to feature some kind of story. We never decided what kind of story it was going to be, since we were going to leave it as a final thought. However, in the end, we declared the story to be out of our scope. In fact, there is very little text in the game that is not informational. This ended up working in our favor as it freed up the rest of our time to work on polishing the technical and artistic aspects of the game, rather than shoehorning in a story that would not have fit in the first place.

7.2.6 Successful scope cuts

The scope of our project was initially much larger than what it is now. This is completely normal for many games. Lots of things got cut, but we always made sure as a team to discuss why it was being cut and what it would impact. Almost everything that was cut was either for flavor, or a system that was wholly unique from the rest that did not provide enough impact on the gameplay to be worth taking the time to implement. This mostly served to free up time for the coders, as most of the art assets that were planned from the beginning did make it into the final. Designating aspects of the game as stretch goals and cutting fast and early were really effective in keeping the game's final scope small and manageable.

7.2.7 Four term MQP

The majority of MQPs at WPI are completed within three terms. However, one of our team members is a double major, which required us to plan for a four term MQP. This was overall a good decision, as we would not have been able to complete the project in just three terms. Having the extra term was essential to being able to continue working on and polishing the game to a completed state.

7.3 Cut content and future features

During the production of *Purradise City*, multiple planned features had to be cut in order to narrow our scope. These features were all planned from the very inception of the project during A term and were ideas that the team felt very strongly would help the game, but we would be okay without. We felt it was important to discuss the more major features that were cut during production. The team plans on implementing these after the end of the school year and before the release of our game.

7.3.1 Building scoring

Each sub tag was to be further categorized into cluster, spread, and neutral. At the end of the game, VP would be assigned for each tile with a cluster tag. The owner of the cluster building would be assigned one point for each neighboring tile occupied with the same tag, regardless of the tile's owner. For each occupied tile with a spread tag, the player who owns it would lose a point for each occupied tile, owned by any player, that is within two hex spaces of it that also has the spread tag. Unfortunately, it proved to be a large challenge for our tech team to implement this feature, so we decided to scrap it for the time being.

7.3.2 Upgrade cards

Upgrade cards were intended to be a third type of card. They would be upgrades for specific buildings, and would be placed into the deck after that building had been built. Players would draw them from the building deck, and any player would be allowed to upgrade any building. They were meant to provide an extra layer of complexity to the use of buildings. For instance, a player may believe they had gotten the upper hand by placing a very good building on the board, but that would also allow a different player to get the upgrade, which would usually be even stronger than the base building. While we would have liked this feature to be in the game, it had gotten to the middle of D-term before discussion of the upgrade cards' implementation began. At that point, the art team was still finishing up all the event and building cards, and did not have the time to draw any more cards.

7.3.3 Time Purriod effects

During the design phase, we had many discussions on what the effects of changing the Time Purriod could be. As *Purradise City* takes place over 200 years, we wanted the players to feel like time was changing. This would be with both mechanics, and aesthetic differences. We

wanted to have building and event cards that would be added or removed from the deck based on the current Time Purriod, such as the NYASA space station only being available after the year 2000. We also wanted color filters and audio differences to signal the current Time Purriod, like a sepia filter for the 1930s or pop music for the 2010s. However, we decided quite early only that this was one of the least important features for us to include, so it was cut from the current game version.

7.3.4 Event cards based on placed buildings

Similarly to the cards currently in the deck being based on the Time Purriod, we wanted certain event cards to only appear in the deck after specific buildings were placed. An example of this is the card "Evasion of the Claw", which depicts a criminal running from the police. If the current city didn't have a police station built, it would be strange for this card to be available, so we wanted it to be added to the deck after a player places the police station. Since we also cut the decks changing based on the Time Purriod, we decided to cut this feature as well for consistency.

7.4 Conclusion

In the end, we are very proud of what we accomplished with *Purradise City*. Our project was an overall success. We learned much about scope, programming, implementation, and art during the course of the project. We also believe we succeeded in creating a game that is genuinely fun for people to play. The team has decided to continue working on *Purradise City* for a while after the term ends in order to add some final polish to it before publicizing the game. Overall, we believe that we created a fun and unique game that will serve as a strong portfolio piece for all the team members. We will take the lessons that we learned during development to heart, and continue to improve as we move into future projects.

Bibliography

Celso Riva. 2015. Making and selling visual novels and dating sims. (July 2015). Retrieved April 16, 2023 from

<https://www.gamedeveloper.com/business/making-and-selling-visual-novels-and-dating-sims>

Civilization V. Firaxis Games and 2K. Released 2010. <https://civilization.com/>

Dandelion Wishes Brought to You. Cheritz. Released 2012.

https://store.steampowered.com/app/321290/Dandelion_Wishes_brought_to_you/

DOVA-SYNDROME. Operating since 2008. <https://dova-s.jp/EN/>

Eleanor Rogers. 2021. Market report - dating simulation games by. (July 2021). Retrieved April 16, 2023 from

<https://falwriting.com/new-blog/2021/7/4/market-report-dating-simulation-games-by-eleanor-rogers>

Furry Scale. 𐐀𐐁. 2010. Image retrieved from:

<https://dic.pixiv.net/a/%E3%82%B1%E3%83%A2%E3%83%8E>

Hailey van Braam. 2021. What color is pastel yellow? symbolism, hex, RGB and psychology.

Retrieved April 16, 2023 from <https://www.colorpsychology.org/pastel-yellow/>

Hatoful Boyfriend. Mediatonic and Hato Moe. Released 2014.

https://store.steampowered.com/app/310080/Hatoful_Boyfriend/

Hustle Cat. Date Night. Released 2016. <https://datenightto.itch.io/hustle-cat>

Pandora Hearts. Jun Mochizuki. Released 2006. Image retrieved from:

<https://mochijun.fandom.com/wiki/Cheshire/Gallery>

Pastel. Cambridge Dictionary. Retrieved April 24, 2023 from

<https://dictionary.cambridge.org/us/dictionary/english/pastel>

Settlers of Catan. Klaus Teuber and Kosmos. Released 1995. <https://www.catan.com/>

Terraforming Mars. Artefacts Studio and Twin Sails Interactive. Released 2018.

https://store.steampowered.com/app/800270/Terraforming_Mars/

Xiaolan You. 2017. Otome Games, Character and Plot Tropes in Japanese Otome Games.

Retrieved April 25, 20203 from <https://sites.duke.edu/unsuitable/otome-games/>

Appendix A: Design document

Purradise City

Developed By:
Zack Koval
Erin Marczewski
Percy Rynkowski
Kateri “Kiki” Bajer

Revision: 0.0.1

Game Summary

Purradise City is an engine building game with a "catboy" twist where players work together to build a city, while trying to gain the most influence over it at the same time.

- 16 playable factions
- Construct buildings to improve the city and increase your own income and influence.
- 2-4 local players

Target Platform(s)

- Windows PC
- 16:9 Resolution

Game Overview

Catboy / Island / Engine-Building & City Building Game

Purradise City focuses on creating a light-hearted, yet competitive, experience with cute catboy aesthetics. While normally a more serious and strategic genre, *Purradise City*'s priority is creating a gameplay loop that is fun to play and easy to pick up. While the game has a decent amount of complexity, much of the game's more miniscule mechanics are calculated by the game itself rather than the players. This allows for less of a cognitive load on the players.

Core Gameplay Mechanics

The gameplay of *Purradise City* intends to be most similar to popular board game *Terraforming Mars*, a game where 2-4 players work together to build a city on a hex based grid. Players compete with each other in order to increase metrics, which will in turn grant them Voting Points at the end of the game.

- Multiplayer city-building game
- Casual catboy experience

Core Design Pillars

1. Make a fun and light hearted game
2. Catboy Theming
3. Engine Builder
4. City Builder

Story and Gameplay

Story

Purradise City's story is quite minimal, taking the tone of a light-hearted retelling of the city's construction throughout the time periods. The overarching story will be told in dialogue boxes on the bottom of the screen, namely via an omnipotent narrator with occasional cut-ins from faction leaders as is relevant. Flavor text provides information on the world, factions, and other trivia so as to better flesh out the environment around the player.

Core Gameplay

After setup, the game function as follows, with a chart of this below:

1. All players gain income
 - a. Gain or lose resources equal to the amount of generation they have
 - b. draw 5 cards
2. Each player rotates taking turns where they:
 - a. Perform up to 3 actions from
 - i. playing cards
 - ii. using core actions
 - iii. activating actions on buildings they have already built
 - b. Pass the turn, at which point they are skipped in the turn order until we reach Step 3
3. Advance Time
 - a. Remove and add cards from the deck based on Time Purriod
 - b. If this is the 9th time reaching this step, go to Step 4
 - c. Otherwise go to step 1
4. Score Game

Core Loop

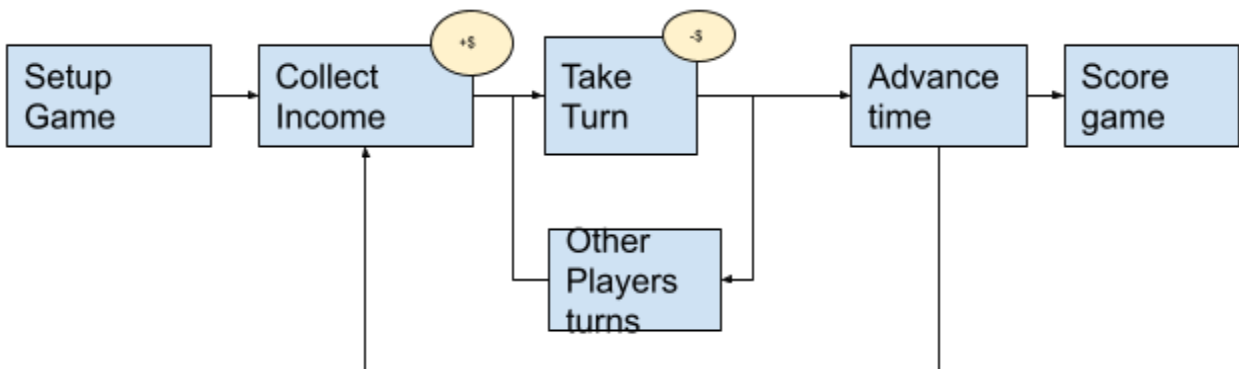

Meta-Games

Resource System

There are 5 Resources. Money, Material, Labor, and Public Relations (PR) and Suspicion. For each resource you track 2 stats: Current Amount, and your Current Generation. The Current Amount is how much you have right now. You cannot have less than 0 of any resource, or fractions of a resource. Current Generation is how much of the resource you get at the beginning of each Time Purriod. This number cannot be less than 0, except for suspicion, and cannot be a fraction.

Money, Material, Labor, and PR

Money is the general currency in the game. Everything costs money, and money is always usable. Material, Labor, and PR all discount certain types of cards. Material with Building, Labor with Upgrade, and PR with events. When playing a card, you can choose to spend the associated resource for the card, and for each Material, Labor, or PR you spend, the Money cost is reduced by 2, but not to less than 0. Example: a Building that Costs 5 money, could be paid for with 5 Money, 3 Money and 1 Material, 1 Money and 2 Material, or 3 Material.

Suspicion

Suspicion works differently than the other resources. Some cards have the “Illegal” tag on them. These cards will usually give you Suspicion. Every suspicion you have removes 1 VP at the end of the game. Illegal cards tend to be more powerful and cheaper than most other cards though.

There are many ways of reducing Suspicion from 1 time Events, to cards that reduce your Suspicion Generation. Most Factions start with no Suspicion Generation, and unlike other resources you can have Negative generation. That means at the beginning of each Time Purriod, you lose some of your suspicion. You cannot have a negative current amount of suspicion however, So if you would lose suspicion you do not have, the extra removal is wasted.

Tag System

Tags are split up into 4 Super Types:

- Community
- Government
- Corporate
- Illegal

Every single card must have one, and only one, Super Type.

In addition, there are 8 tag subtypes:

- Housing
- Food
- Education
- Entertainment

- Technology
- Transportation
- Medical
- Occult

District System

To make the map feel more like a real city, we have 8 districts placed on the map. Each District affects 6 out of the 12 tags, 3 as a benefit, 3 an extra point for buildings of one supertype, and one negative point for buildings of its opposed supertype

Placement System

All tags are either

- Cluster
- Spread
- Neutral

At the end of the game, for every occupied tile with a cluster tag, you gain 1 point for each occupied tile next to it with the same tag.

At the end of the game for every occupied tile with a Spread tag, you lose 1 point for each occupied tile within 2 hexes of it with the same tag.

It does not matter how many cluster or spread tags are on the particular tile, it just increases or decreases the number of tags counted in the check (An XY/AB building next to 2 buildings of XY, and a building of YAB would be net +2 points, where XY are cluster and AB are spread)

User Interface / Screens

1. Main Menu

- Game Logo
- Settings
- Player setup
- Extras

2. Faction selection screen

- a. Faction type selection
- b. Specific faction selection

3. Gameplay Screen

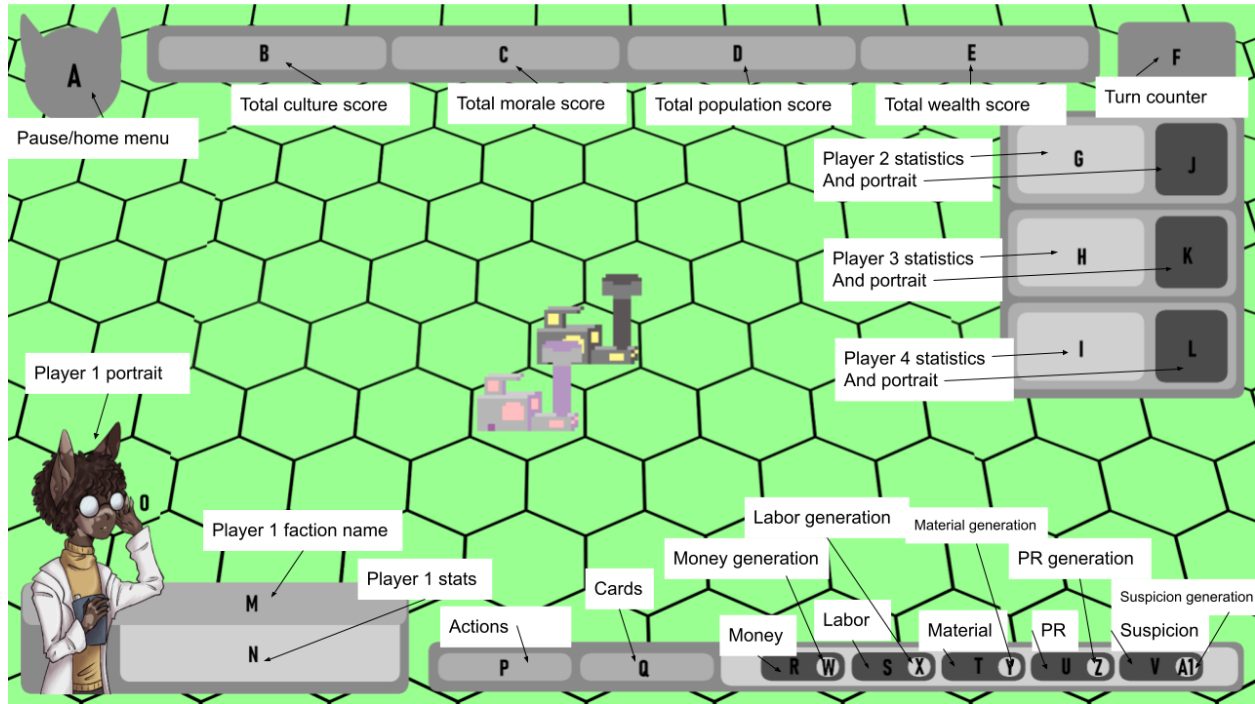

4. In-Game Menu Popups

Multiple UI menus will open up small pop-up menus for additional information. These include the pause/settings button, the core actions button, the cards button, the played cards, and the character portrait.

- Pause/settings button opens up the same settings menu as the main menu settings, as well as pausing audio and animations.
- Core actions button opens the menu allowing the player to select from the 4 core action buttons.
- Cards button opens the list of the player's current cards allowing them to select to look closer at each card and play cards.
- Played cards button opens the list of all cards the player has previously played, allowing them to select to view each card.
- Clicking on the character portrait opens the faction menu displaying the faction name, image, starting resources, special action, and informational blurb.

5. Cards

Each card has informational text on it providing everything a player needs to know about the card in order to use it. They also have flavor text and images to help distinguish each card and provide immersion. The player may select the cost button on the card in order to choose to use resources to lower the cost. The backside and edges of each card are color coded for the card's type.

- Blue = Buildings
- Green = Upgrades
- Red = Events

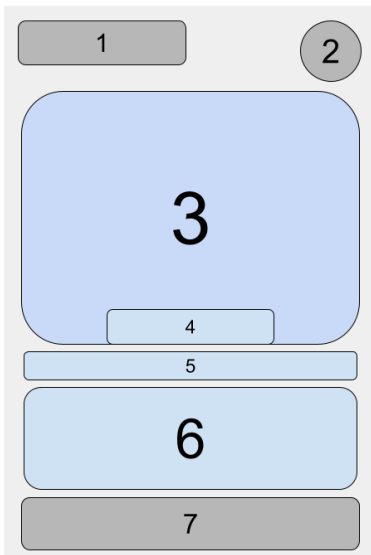

1. Name of the card
2. Card cost
3. Card art
4. Card type
5. Card tags
6. Card description
7. Flavor text

6. Pause screen

- a. Continue
- b. Suspend game
- c. Home menu
- d. Settings

7. Settings Menu

The settings menu contains basic settings such as sound mixing (master, music, effects) and accessibility (color blindness mode).

8. Player Setup

The player setup menu exists to test controllers and to choose the number of players playing the game.

9. Game End Screen

When the game ends, the total scores of each player are tallied on a new screen. The scores are represented in bars where each section of the bar is colored based on the type of point. The types of points are voting points, morale, culture, wealth, population, and suspicion. After the points are tallied, the winning player is highlighted and their faction character is displayed as the winner.

10. Placing a Building

When placing a building through a core action or card, a small pop-up displays the statistics of the location where it is potentially being placed. This is because of the zoning

mechanic. A player will be able to tell from this popup using +/- and color coded (blue/red) numbers whether the cost of placing the building is increased or decreased, and whether or not there are any benefits to placing the building in that location. Buildings are also highlighted blue/red based on whether or not they can be placed in that location. Surrounding buildings are highlighted blue/red based on whether or not they provide a benefit or detriment to the newly placed building.

First Time Experience

Setup:

1. Each player chooses a faction.
2. Each player gets starting resources based on their faction.
3. Randomly generate a play order.
 - a. For paper games, assume clockwise turn order, and determine who goes first.

Structure of the Game

The game is divided into 9 Time Purriods. Each Time Purriod represents 25 years in the history and development of the City, from the year 1900, to 2100. At the beginning of each Time Purriod you do the following:

1. All players, in order, gain or lose resources according to their income amounts.
2. All cards that are not usable in this Time Purriod are removed from the deck.
3. All cards that are added by this Time Purriod are added to the deck.
4. All players, in order, draw a total of 5 cards from either the build or event deck.

Then, players start taking turns until everyone has Passed (see: Taking Turns). Once every player has Passed, the Time Purriod ends, and the player order shifts. The last player in the order from the previous turn becomes the first player. The previous first player becomes the second player, and so on. Now the next Time Purriod begins.

The Start and End of the Game:

During the First Time Purriod of the game (1900-1925), players do not gain or lose resources according to their income, and instead get their Factions starting resources as noted in Setup.

The Last Time Purriod (2100) works differently, as it is the ending phase of the game. Players do not draw any cards at the beginning of the Time Purriod and only get 1 final turn each. Once each player takes their final turn, complete a final tally of Voting Points (VP) gained throughout the game. The player with the highest VP total wins the game. Their Faction has had the largest influence on the development of Purradise City, and becomes the primary leaders of the city.

Taking Turns.

On your turn, you may either take up to 3 actions or pass the turn. Actions are doing one of the following:

- Using a Core Action
- Playing a Card from your hand
- Activating your Faction's Activated Power

To perform the action, first pay all costs of the action, then perform the effects of the action in the order written.

After you have performed your first action, you may continue taking actions to a total of 3, or skip to the end of your turn. Then, play continues to the next player in order.

If you choose to Pass your turn without taking any actions on that turn, you are removed from the turn order, and take no more turns until this Time Period ends.

Asset List

Art

Purradise City features entirely 2D artwork. There are multiple categories of artwork including the map and buildings, the faction characters, the UI, card flavor art, and the logo.

- Map/board
 - We currently plan to feature one detailed gameplay map. The map is an isometric hex grid similar to what is seen below. The map will feature a variety of terrains and environments to provide visual interest.

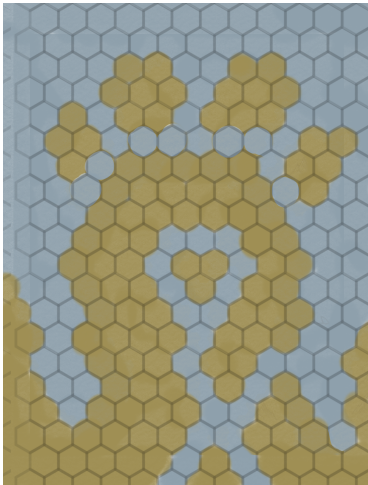

- Buildings
 - When a building card is played, a physical building is placed onto the map. Each building card places a unique building on the map (although multiple instances of each building is allowed). When a building upgrade card is placed, a small visual change occurs for the building that was upgraded.

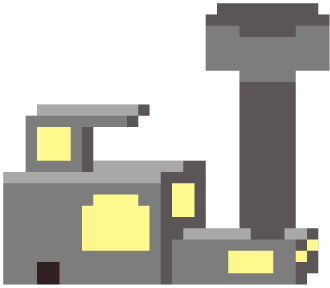

- Characters
 - The game features 16 playable sub-factions sorted into 4 major factions. Each player chooses what faction they wish to play as and are then represented by that faction's leader. Each faction leader is represented by a 2D bust on the game screen and in the faction informational menu. The factions are as follows:
 - Money
 - Bankers
 - Scientists
 - Mafia
 - Mercenaries
 - Material
 - Underground Trade
 - Mining & Lumber
 - Farming
 - Fishing
 - Labor
 - Union
 - Education
 - Healthcare
 - Corporate
 - Public Relations
 - Church
 - Cult
 - Musicians
 - Artists



- UI
 - The UI is discussed in the UI section of this document. However, every button and what it represents is considered an asset. The UI will mostly contain drawn buttons with text applied.
- Cards
 - The game features over 150 unique cards. Each card follows a template with informational text boxes and a unique blurb. Each card also has a unique piece of 2D artwork to represent what it does.
- Logo
 - Purradise City's logo is a hand-drawn 2D asset. There will additionally be a smaller desktop icon.

Writing

- Purradise city's writing mostly encompasses informational text and blurb flavor text. Cards especially need to have names, tags, costs, descriptions, and blurbs. Factions also have descriptions and statistics. Otherwise, since there is no major prevailing story, the game is rather text-light outside of the initial opening of the game where the "story" is presented in text.

Sounds & Music

- Sound effects will mostly include sounds for placing and upgrading buildings, playing events, and obtaining resources.
- The game will feature some kind of relaxing or upbeat background music.

Appendix B: A Term timeline

Upcoming Dates:

- Protofest 10/26
- AlphaFest 11/11

Notable Events:

- PAX East; IMGD Booth Spot

Terms:

- B-term (Oct 24th to Dec 16th)
 - Have paper outline done as a deliverable
- C-term (Jan 10th to March 3rd)
- D-term (Mar 13th to April 27th)

Major Milestones, and what they mean for us:

- Prototype
 - A playable paper prototype.
 - Mockups finished
- First Playable
 - The first game version with functional major gameplay elements. All major mechanics are represented in one way or another, even if the final way we implement them ends up being slightly different.(ranked in order, all of the no's are listed in order they could become yes.)
 - i. Draw cards from a deck
 - ii. Values for resources and metrics go up and down
 1. Show increase of resource according to generation
 - iii. A board you can place things on
 - iv. Be able to play any cards in hand in any order, assuming can afford
 - v. 2 separate players, with their own details tracked separate
 - vi. No district or placement mechanics yet

- 1. Maybe just map, but no effect
 - vii. Only 1 turn
 - 1. Definitely no Time Purriod change but maybe multiple turns if loop isnt too hard
 - viii. No title page or menus other than needed to take a turn
 - 1. If exist, very basic
 - ix. No faction choice
 - 1. No faction implementation, but will try to design such that adding it isnt hard.
- Game Architecture Graph Finished
- Art Bible Finished
- At least one ‘representative’ asset for each overall asset group (finished half-body sprite, finished UI box, finished building)
- First playable map
- Vertical slice
 - A fully-playable portion of our game. In our case, we want to have all major mechanics implemented, enough cards to last one Time Purriod, and at least placeholder assets for everything.
 - Character Portraits finished.
 - Enough buildings for a single Time Purriod finished.
 - A few UI layouts completely finished.
 - Some sound has been added
 - Game logo is at least a “bare minimum” (might not be finalized but we can go with it as a theoretical final if needed)
- Alpha
 - A game that is playable from start to finish. All major assets are finished, all major mechanics are implemented and refined,
 - All buildings finished.
 - Most of the card art is finished.
 - Logos for all art finalized.
 - Bare minimum sound added.

- Beta
 - Ready for release with minor bugs that we need to noodle around with. ‘Juice’ aspects might not be implemented yet, but we have the ability to go in and add said ‘Juice’.
 - All art assets finished.
- Release

Proposed Dates for each Major Milestone:

- (Refined) Prototype
 - ProtoFest. We remake the paper prototype in a more clean manner, make sure all the cards are finalized and (at least somewhat more) balanced, and nail down other “drifting” bits of information. Does not necessarily have to be super pretty, but will get us beyond the ProtoType that we currently have and force us to present it to an audience.
- First Playable (11/11)
 - AlphaFest. At least enough done on the technical side of things for players to be able to get through a single round of a game, with mechanics like having cards in your hand, placing buildings on tiles, having materials, etc being implemented. Not all placeholder assets need to be done, but enough for the First Playable to be finished.
- Vertical slice
 - End of B-term/Beginning of C-term.
- Alpha
 - Middle of C-term. All card designs are done, UI is at a passable stage
- Beta
 - End of C-term

Appendix C: B Term timeline

Terms:

- B-term (Oct 24th to Dec 16th)
 - Have paper outline done as a deliverable

Major Milestones, and what they mean for us:

- Vertical slice
 - A fully-playable portion of our game. In our case, we want to have all major mechanics implemented, enough cards to last one Time Purriod, and at least placeholder assets for everything.
 - Character Portraits finished.
 - Enough buildings for a single Time Purriod finished.
 - A few UI layouts completely finished.
 - Some sound has been added
 - Game logo is at least a “bare minimum” (might not be finalized but we can go with it as a theoretical final if needed)

Proposed Dates for each Major Milestone:

- Vertical slice
 - End of B-term/Beginning of C-term.
 - Due Nov 18th
 - Code
 - Fix -1 money bug
 - Fix card click bug
 - Art
 - Colour pallets
 - 2 factions
 - 2 painted buildings
 - General
 - Road map till end of term

- Due Nov 22nd
 - Code
 - Make full-size map and assign districts
 - Make list of Faction powers
 - 4 general powers
 - 16 individual powers
 - Starting resources
 - Art
 - Colour pallets (brain stupid, forgot)
 - Fix both logos
 - UI
 - Rest of pixel art repainted
 - General
- Due Dec 2nd
 - Code
 - UI (for all things that exist up to point)
 - Start district code
 - Visuals on map
 - Affect card price
 - Affect score
 - Turn order and Time Purriods,
 - Art
 - Place fonts on cards & make a decision
 - Tag icons
 - General
- Due Dec 9th
 - Code
 - Make core actions
 - Make player action list
 - Finish district
 - Start relational placement system

- Cluster tags
- Spread tags
- Visual indication
- Decks
 - Can draw from either deck
 - Time Period can change deck contents
 - After played goes into Cards played area
- Art
 - Cleanup
 - Fix logo
- General
 - Base outline
- Due Dec 16th
 - Code
 - Finish relational placement
 - Finish Decks
 - Implement factions
 - No faction select screen, hardcode assignment to each player
 - Art
 - Cleanup
 - Art bible v3
 - Art mockup
 - General
 - Finalize outline
 -

Revised plan:

- General:
 - Make edits to outline so that it is finalized

- Art
 - Finalize styles; have some sort of page in an art bible that explains the art process behind each major asset type
 - Finalize color palettes
- Code:
 - Make map
 - Make districts (not necessarily code with district interaction, but code that ensures the districts exist)

Appendix D: C Term timeline

week 1: jan 10th (start of week)

week 2: jan 17th [SUCCESS]

- Water & Grass tiles completed; at least 2-3 variations of each
- District Outlines (4 of them) all finished
- First draft of UI (both art and text) finished, split up, and sent
- Creating a hard style guide that can be followed by both artists, particularly with color schemes
- © Restructuring the deck & hand system so that it can properly be sent between players

week 3: jan 23rd

- © Finishing functional UI for all elements. Not everything will be implemented in detail, but creating all the setups for all the screens involved
 - This will showcase the resources and points in a Slightly Better way than it has been right now (aka not a big text wall)
- Finishing up logo & icons
- Continuing working on Faction sprites
- 3x Buildings
- 3x Upgraded versions of buildings

week 4: jan 30

- © Creating tag system & polishing out building placement, and how this interacts with things like the money system.
- © Implementing a good handful of cards that involve simple operations (adding/subtracting resources)
- © Implementing a good handful of buildings that involve simple operations
- 7x Buildings (normal or upgraded)
- More variations of the water and grass tiles
- Finished up with the Faction sprites
- 1-2 Card Art
- Advisor Playtest

week 5: feb 6th

- © Implementing all UI elements
- © Starting to implement more complex cards
- © Implementing the ability to interact with other players via your cards
- 10x Buildings (normal or upgraded)
- 7x Card Art

week 6: feb 13th

- © Implementing turn system
- 10x Buildings (normal or upgraded)
- 7x Card Art

week 7: feb 20th

- © Implementing faction perks
- © Implementing tag system
- 10x Buildings (normal or upgraded)
- 7x Card Art

week 8: feb 27th

- © Polishing up UI interactions
- © Continuing to add more complex cards
- 10x Buildings (normal or upgraded)
- 7x Card Art

Appendix E: D Term timeline

Notable days:

- April 21st is project presentation day; WE DON'T ACTUALLY HAVE MAY 1-3
- Pax East is March 23rd to 26th; Kiki is volunteering during Pax and schedule has not yet been released so just keep a pin in that babie
- Paper done Fully 4/27
- Showfest 4/28

notes and goals for d term:

- Finish the game (overgeneralized goal but yknow)
- I will be less specific about what needs to get done for art team; updates similar to last term are expected, but at this point art team has a better grasp of what needs to get done than I do. Specificities about art direction and tweaks needed to be made can be discussed between art team, tech team will likely simply request assets when needed.

week 1; march 13th (start of the week)

- GOAL: Take playtesting feedback and fix it
- For art:
 - Tweaking art assets to create better contrast and visibility (namely ui stuff)
 - Turning at least a Few building assets into cards
- For tech:
 - Fixing bugs that appeared during playtesting; focusing on some of the biggest ones first
 - Namely the duplicate card bug (cards appearing
 - Adding some of the biggest requests from tech part of the demo (namely; tooltips, making some parts of the ui clearer/better separated, etc)

week 2; march 20th

- Kiki will likely not be the most active because they have 2 games at pax AS A
PREEMPTIVE WARNING
- GOAL: add some minor but necessary features
 - Namely: Title screen, basic audio, potentially little polish things
 - Screens before the game itself; choosing the factions, for example!

- Depending on workload of art team, might assign them to collect audio assets (I have a bunch of resources for libraries, the task would be sorting through said resources to pick things out; NOT 100% SURE ON THIS THOUGH AND IF ART TEAM HAS HUGE WORKLOAD IGNORE THIS)

week 3: march 27th

- GOAL: Implementing and cementing major features that were not present in demo to fully complete the turn system
 - Including, but not limited to...
 - Core actions
 - Player actions
 - Basically; every button on the screen now needs a Use

week 4: april 3rd

- LEAVING THIS ONE BLANK; I want us to have time during the end of week 3 to sit down, look where we're at, and decide where we next want to implement things taking into account what work we just did so it's easier for us to pivot. Will fill out the following weeks afterwards

week 5: april 10th

- See week 4
- Percy will be gone 9th/10th and most of the 11th

week 6: april 17th

- See week 4

week 7: april 24th

- THE FINAL WEEK
- Project presentation day; at this point, unless we're super confident in something, we are NOT implementing any new

Appendix F: Asset list

Name	Type (Sprite, Portrait, Button, Illustration, Logo)	Description (if necessary)	Completed? (y)	tested? (y)	Importance (1-3)
Water Tile	Sprite		y		3
Grass Tile	Sprite		y		3

District Outline 1 (Community)	Sprite		n		3
District Outline 2 (Corporate)	Sprite		n		3
District Outline 3 (Illicit)	Sprite		n		3
District Outline 4 (Government)	Sprite		n		3

Name	Type (Sprite, Portrait, Button, Illustration, Logo)	Description (if necessary)	Completed? (y)	Put into game? (y)	Importance (1-3)
Airport	sprite		y		2
Apartment Complex	sprite		y		2
Art School	sprite		y		2
Bank	sprite		y		2
Bar	sprite		y		2
Bis-kittery	sprite	its a bakery	y		2
Boat Housing	sprite		y		2
Campground	sprite		y		2
Cat-thedral	sprite		y		2
Catacombs	sprite		y		2
Catbus	sprite		y		2
Concert Hall	sprite		y		2

Convention Center	sprite		y		2
Dispensery	sprite		y		2
Docks	sprite		y		2
Factory	sprite		y		2
Farm	sprite		y		2
Fast Food Chain	sprite		y		2
Fire Station	sprite		y		2
Fishery	sprite		y		2
Furniture Store	sprite		y		2
Gas Station	sprite		y		2
Graveyard	sprite				2
Hospital	sprite		y		2
Housing Building 1	sprite		y		2
Housing Building 2	sprite				2
Hydropawnics	sprite		y		2
Labratory	sprite		y		2
Library	sprite		y		2
Maid Cafe	sprite		y		2
Mall	sprite		y		2
McMeownsion	sprite		y		2
Meownsion	sprite		y		2
Mewseum	sprite		y		2
Monument 1	sprite				2
Monument 2	sprite		y		2
Movie Studio	sprite		y		2
Movie Theatre	sprite		y		2

Nightclub	sprite		y		2
Office Building	sprite		y		2
Oil Rig	sprite		y		2
Orphanage	sprite		y		2
Park	sprite		y		2
Pizza Joint	sprite		y		2
Police Station	sprite		y		2
Post Office	sprite		y		2
Power Plant	sprite		y		2
Prison	sprite		y		2
Restaurant	sprite		y		2
School	sprite		y		2
School	sprite		y		2
Shipyards	sprite		y		2
Skyscraper	sprite		y		2
Soup Kitchen	sprite		y		2
Space Station	sprite	NYASA headquarters	y		2
Speakeasy	sprite		y		2
STEM School	sprite		y		2
Suburb	sprite		y		2
Supermarket	sprite		y		2
Town Hall	sprite		y		2
Train	sprite		y		2
Whisker Brewery	sprite		y		2
Windmills	sprite		y		2
Zoo	sprite		y		2
Upgraded Airport	sprite				2

Upgraded Apartment Complex	sprite				2
Upgraded Art School	sprite				2
Upgraded Bank	sprite				2
Upgraded Bar	sprite				2
Upgraded Bis-kittery	sprite				2
Upgraded Boat Housing	sprite				2
Upgraded Campground	sprite				2
Upgraded Cat-thedral	sprite				2
Upgraded Catacombs	sprite				2
Upgraded Catbus	sprite				2
Upgraded Concert Hall	sprite				2
Upgraded Convention Center	sprite				2
Upgraded Dispensery	sprite				2
Upgraded Docks	sprite				2
Upgraded Farm	sprite				2
Upgraded Fast Food Chain	sprite				2
Upgraded Fire Station	sprite				2
Upgraded Fishery	sprite				2

Upgraded Furniture Store	sprite				2
Upgraded Gas Station	sprite				2
Upgraded Graveyard	sprite				2
Upgraded Hospital	sprite				2
Upgraded Hydroponics	sprite				2
Upgraded Laboratory	sprite				2
Upgraded Library	sprite				2
Upgraded Maid Cafe	sprite				2
Upgraded Mall	sprite				2
Upgraded McMeownision	sprite				2
Upgraded Meownision	sprite				2
Upgraded Mewseum	sprite				2
Upgraded Movie Studio	sprite				2
Upgraded Movie Theatre	sprite				2
Upgraded Nightclub	sprite				2
Upgraded Office Building	sprite				2
Upgraded Oil Rig	sprite				2

Upgraded Orphanage	sprite				2
Upgraded Pizza Joint	sprite				2
Upgraded Police Station	sprite				2
Upgraded Post Office	sprite				2
Upgraded Power Plant	sprite				2
Upgraded Prison	sprite				2
Upgraded Restaurant	sprite				2
Upgraded School	sprite				2
Upgraded Shipyard	sprite				2
Upgraded Skyscraper	sprite				2
Upgraded Soup Kitchen	sprite				2
Upgraded Space Station	sprite				2
Upgraded Speakeasy	sprite				2
Upgraded STEM School	sprite				2
Upgraded Suburb	sprite				2
Upgraded Supermarket	sprite				2
Upgraded Town Hall	sprite				2
Upgraded Train	sprite				2

Upgraded Whisker Brewery	sprite				2
Upgraded Windmills	sprite				2
Upgraded Zoo	sprite				2

Name	Type (Sprite, Portrait, Button, Illustration, Logo)	Description (if necessary)	Completed? (y)	Put into game? (y)	Importance (1-3)
Altercation	Illustration		y		2
Anti-histamines	Illustration		y		2
Astral Pawjection	Illustration		y		2
Black Fur Dye	Illustration		y		2
Black Market	Illustration		y		2
Bribery	Illustration		y		2
Cardboard Box	Illustration		y		2
Cat Food	Illustration		y		2
Cat Treehouse	Illustration		y		2
Cat's Outta the Bag	Illustration		y		2
Cataclysm	Illustration		y		2
Catnap	Illustration		y		2
Catnip Brownies	Illustration		y		2
Catographer	Illustration		y		2
Catpitalism	Illustration		y		2
City Council	Illustration		y		2
Claw Enforcement	Illustration		y		2

Clawmunism	Illustration		y		2
Clout	Illustration		y		2
Dead or Alive	Illustration		y		2
Declaw	Illustration		y		2
Depurression	Illustration		y		2
Donations	Illustration		y		2
Evasion of the Claw	Illustration		y		2
Favourite Project	Illustration		y		2
Fishy Deals	Illustration		y		2
Flooding	Illustration		y		2
Fundraiser	Illustration		y		2
Fur Enhancers	Illustration		y		2
Furrune Teller	Illustration		y		2
Hiring Agency	Illustration		y		2
Hunting	Illustration		y		2
Impurrsination	Illustration		y		2
Investor	Illustration		y		2
Laser Pointer	Illustration		y		2
Mad Science	Illustration		y		2
Mass Hissteria	Illustration		y		2
Merchant Guild	Illustration		y		2
Mewnshine	Illustration		y		2
Monument	Illustration		y		2
Nekomancy	Illustration		y		2
Pawsitive Reinforcement	Illustration		y		2
Pawverty	Illustration		y		2

Public Announcement	Illustration		y		2
Publicity Campaign	Illustration		y		2
Purramedics	Illustration		y		2
Purrhhibition	Illustration		y		2
Purrivate Investigator	Illustration		y		2
Scandal	Illustration		y		2
Shapeshifting	Illustration		y		2
Spirit Meowdium	Illustration		y		2
Stinky	Illustration		y		2
Task Force	Illustration		y		2
The Ol' Switcharoo	Illustration		y		2
Gone Fishin	Illustration		y		2
Trade Routes	Illustration		y		2
Trade Show	Illustration		y		2
Unionization	Illustration		y		2
Vitail Signs	Illustration		y		2
Airport	Illustration				2
Apartment Complex	Illustration				2
Art School	Illustration				2
Bank	Illustration				2
Bar	Illustration				2
Bis-Kittery	Illustration				2
Boat Housing	Illustration				2
Campground	Illustration				2

Cat-thedral	Illustration				2
Catacombs	Illustration				2
Catbus	Illustration				2
Concert Hall	Illustration				2
Convention Center	Illustration				2
Dispensery	Illustration				2
Docks	Illustration				2
Farm	Illustration				2
Fast Food Chain	Illustration				2
Fire Station	Illustration				2
Fishery	Illustration				2
Furniture Store	Illustration				2
Gas Station	Illustration				2
Graveyard	Illustration				2
Hospital	Illustration				2
Hydropawnics	Illustration				2
Laboratory	Illustration				2
Library	Illustration				2
Maid Cafe	Illustration				2
Mall	Illustration				2
McMeownsion	Illustration				2
Meownsion	Illustration				2
Mewseum	Illustration				2
Movie Studio	Illustration				2
Movie Theatre	Illustration				2
Nightclub	Illustration				2

Office Building	Illustration				2
Oil Rig	Illustration				2
Orphanage	Illustration				2
Pizza Joint	Illustration				2
Police Station	Illustration				2
Post Office	Illustration				2
Power Plant	Illustration				2
Prison	Illustration				2
Restaurant	Illustration				2
School	Illustration				2
Shipyards	Illustration				2
Skyscraper	Illustration				2
Soup Kitchen	Illustration				2
Space Station	Illustration				2
Speakeasy	Illustration				2
Stem School	Illustration				2
Suburb	Illustration				2
Supermarket	Illustration				2
Town Hall	Illustration				2
Train	Illustration				2
Whisker Brewery	Illustration				2
Windmills	Illustration				2
Zoo	Illustration				2
Card Backing	Illustration				3

Name	Type (Sprite, Portrait, Button, Illustration, Logo)	Description (if necessary)	Completed? (y)	Put into game? (y)	Importance (1-3)
Bankers	Portrait		y		3

Union	Portrait		y		3
Church	Portrait		y		3
Underground Trade	Portrait		y		3
Scientists	Portrait		y		3
Healthcare	Portrait		y		3
Cult	Portrait		y		3
Mining & Lumber	Portrait		y		3
Mercenaries	Portrait		y		3
Education	Portrait		y		3
Artists	Portrait		y		3
Farmers	Portrait		y		3
Mafia	Portrait		y		3
Corporate	Portrait		y		3
Musicians	Portrait		y		3
Fishing	Portrait		y		3

Name	Type (Sprite, Portrait, Button, Illustration, Logo)	Description (if necessary)	Completed? (y)	Put into game? (y)	Importance (1-3)
Home Menu Button	Button		y		3
Total Score Header	Button		y		3
Turn Counter	Button		y		3
Player Stats Panel	Button		y		3
Current Player Panel	Button		y		3
Player Actions Bar	Button		y		3
Player Resource Bar	Button		y		3
Settings Menu	Button				3
Current Cards Window	Button		y		3
Played Cards Window	Button		y		3

Regular Actions Window	Button		y		3
Player Info Window	Button		y		1
Player Setup Window	Button		y		1
Pause Menu	Button		y		3
Start Screen	Screen		y		3
End Screen	Screen				3
Colour Variations	Test		y		2
Faction Select Screen	Screen		y		

Purradise City Main Logo	Logo		y		3
Purradise City Desktop Icon	Logo		y		3
Money Icon	Logo		y		2
Labor Icon	Logo		y		2
Material Icon	Logo		y		2
PR Icon	Logo		y		2
Suspicion Icon	Logo		y		2
Corporate Icon	Logo		y		3
Community Icon	Logo		y		3
Illicit Icon	Logo		y		3
Government Icon	Logo		y		3
Entertainment Icon	Logo		y		3
Occult Icon	Logo		y		3
Medical Icon	Logo		y		3
Education Icon	Logo		y		3
Transportation Icon	Logo		y		3
Technical Icon	Logo		y		3
Housing Icon	Logo		y		3

Wealth Icon	Logo		y		2
Morale Icon	Logo		y		2
Culture Icon	Logo		y		2
Population Icon	Logo		y		2

Appendix G: Art bible



Color Palette

Purradise City uses a pastel themed color palette.

The base set of colors uses yellow, blue, purple, pink, and teal.

Harsh reds and greens are to be avoided - reds are diluted with pink, and greens with blue.

Factions and super tags use the same four base colors of yellow, purple, blue, and pink. These are the four most used colors for the game in various shades with similar saturation.

Greys are OK for more "gritty" colors.



Stylization

Purradise City uses a combination of lined paintings, lineless paintings, and lineless sprites.

Paintings are used for the user interface, icons, logo, characters, and cards.

Sprites are used for the map tiles and placeable buildings.

Paintings for icons and UI must follow the color palette conventions and use rounded shapes with minimal soft shading.

Sprites are low-detailed due to being small. They also follow the color palette, but use harsher shapes and shading in places for clarity.



Logo

The logo for Purradise City uses the painted icon style. However, the initial conception of the logo used a much more harsh-edged style that was eventually scrapped to better fit the theme of the game.

Four logos were presented, and two were picked. One logo is for promotional material and in-game, and one logo is an app icon.

Logos are very rounded and soft. The shading style is similar to that of the UI and icons, but with lower contrast.

Both logos are 480x480px, 300 DPI.



User Interface

The user interface is painted similar to the game's logos. Only rounded corners and shapes are used.

It also follows the color palette and may eventually have alternate color versions.

The UI is minimal for a game that heavily relies on UI and contains many pop-up menus and hover texts.



Icons

Purradise City uses numerous icons to represent in game concepts. All icons use the lined painted style and follow the color palette. Most icons are limited to one colour.

All icons MUST have a distinct shape to avoid confusion even if all the colors are distinct.

Icon colors are chosen based on the icons relationship to the game. The icons for the resources use that resource's color, and the tag icons use that tag's color.

Icons may contain lined details to improve visual clarity.

Icons are 140x140px, 300 DPI.



Building Sprites

Step 1 - The Cubes

All buildings start from a set of premade cubes. The structure of the building is built out of these building blocks.

These can be modified if needed.

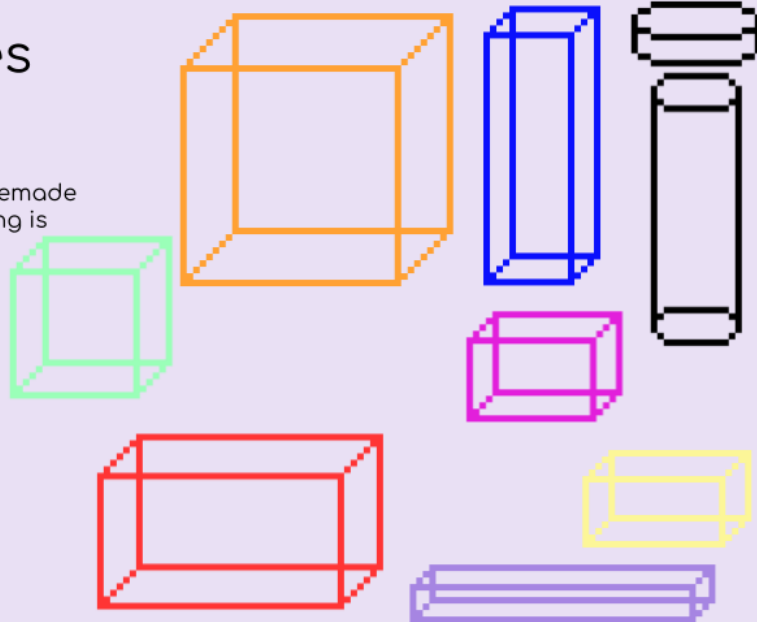

Building Sprites

Step 2 - Building out a base

Base cubes are brought in and arranged to create the base structure for the building.

Base cubes may be altered from their original shape in the final structure. Additional structures or shapes may be added depending on the building.

Different parts are done in different colors to keep track of which part of the building is which.

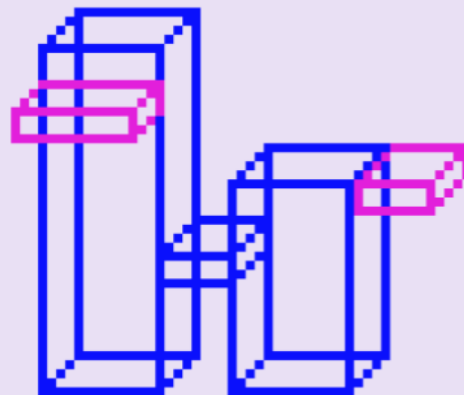

Building Sprites

Step 3 - Add Flat base colors

The color of the building is picked based on what metrics the building is related to mechanically.

The top roof is given a lighter version of this color and the side of the building that is visible is given a darker shade.

Other variations of the base color are used if another color is needed.



Building Sprites

Step 4 - Add windows

Windows are added first with the base yellow color.

They are important to adding a sense of cat tower-ness to the buildings.

Around some of the window edges are given a line of slightly darker yellow to give the illusion of depth.



Building Sprites

Step 5 - Add details

Now it's time to decorate the building with any necessary details.

Any and all colors of details are picked from a predetermined color pastel palette, or derived from palette colors.



Building Sprites

Step 6 - Refinements

After being reviewed by other team members, any refinements based on feedback were made.

Other changes were also occasionally applied (depending on the building) to keep the buildings looking as cohesive and polished.



Building Sprites - Transportation Buildings



Building Sprites - Transportation Buildings

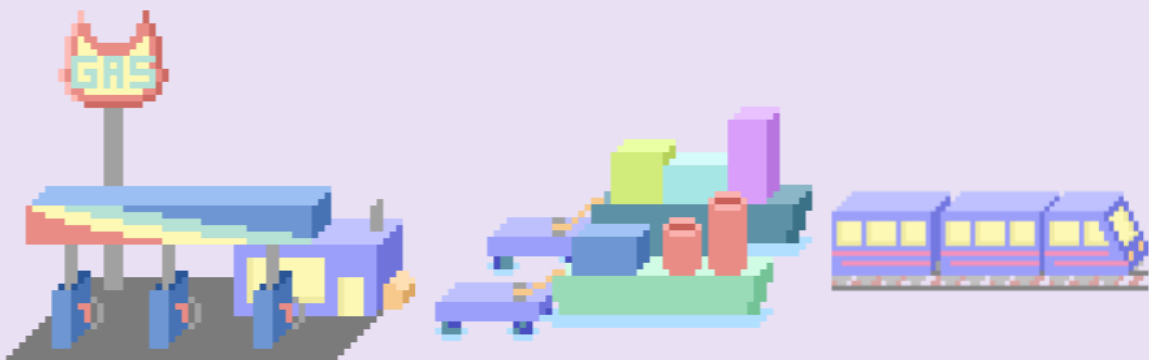

Building Sprites - Housing Buildings



Building Sprites - Housing Buildings



Building Sprites - Housing Buildings



Building Sprites - Education Buildings



Building Sprites - Education Buildings

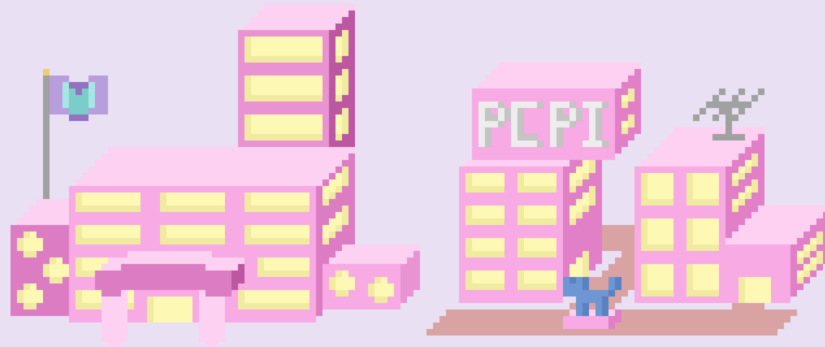

Building Sprites - Corporate Buildings

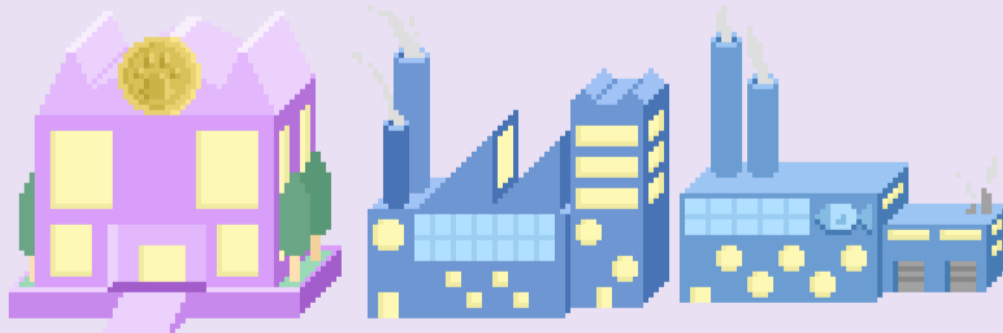

Building Sprites - Corporate Buildings



Building Sprites - Corporate Buildings

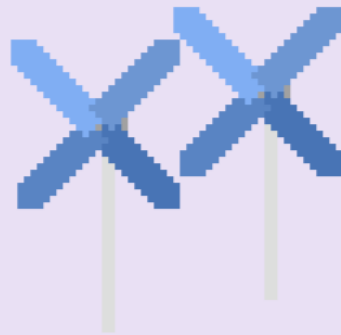

Building Sprites - Entertainment Buildings



Building Sprites - Entertainment Buildings



Building Sprites - Entertainment Buildings



Building Sprites - Entertainment Buildings



Building Sprites - Food Buildings



Building Sprites - Food Buildings



Building Sprites - Food Buildings



Building Sprites - Occult Buildings



Building Sprites - Medical Buildings

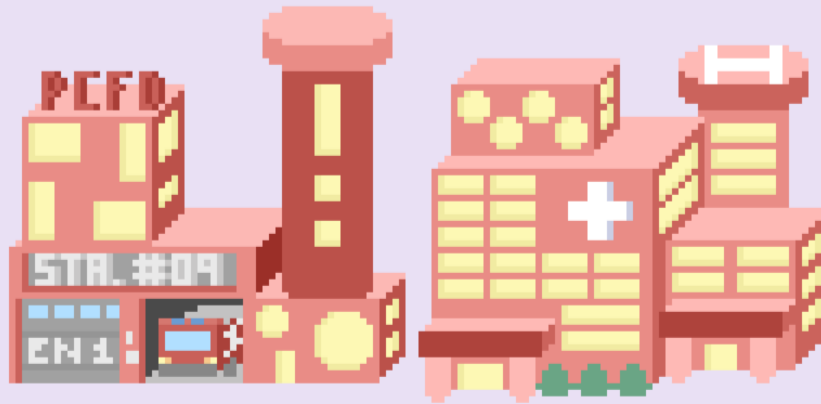

Building Sprites - Tech Buildings

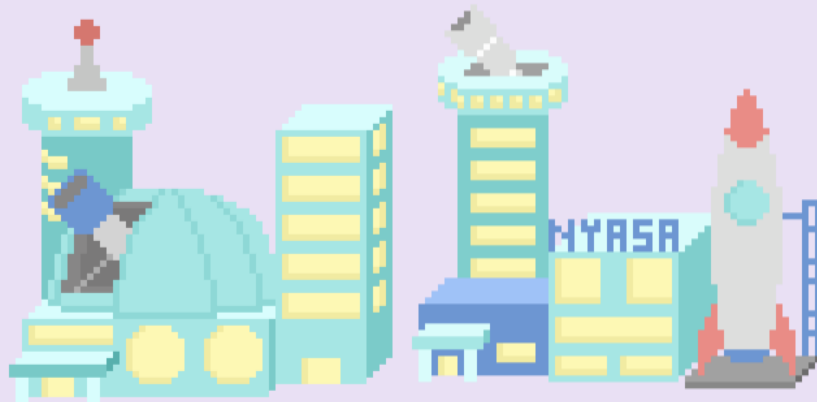

Building Sprites - Morale Buildings



Building Sprites - Government Buildings



Building Sprites - Government Buildings

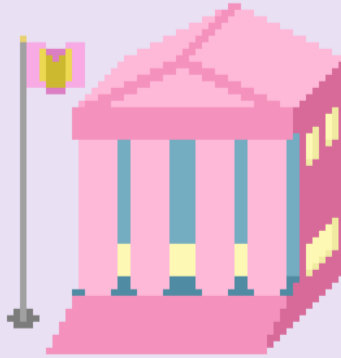

Building Sprites - Underbelly Buildings



Building Sprites - Other Buildings



Map Tiles

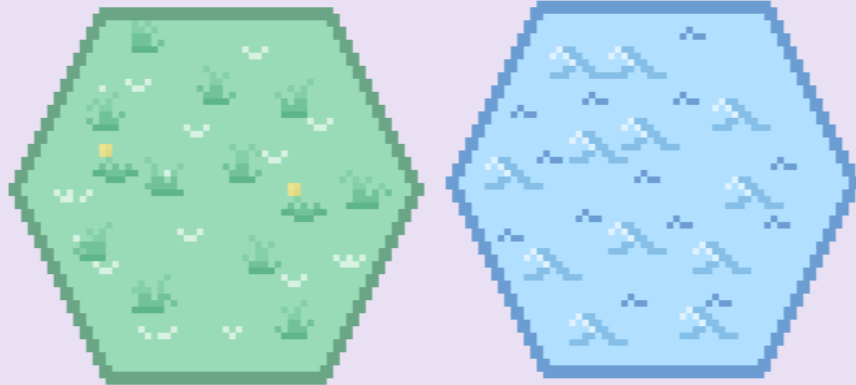

Map Tiles - Tile Borders

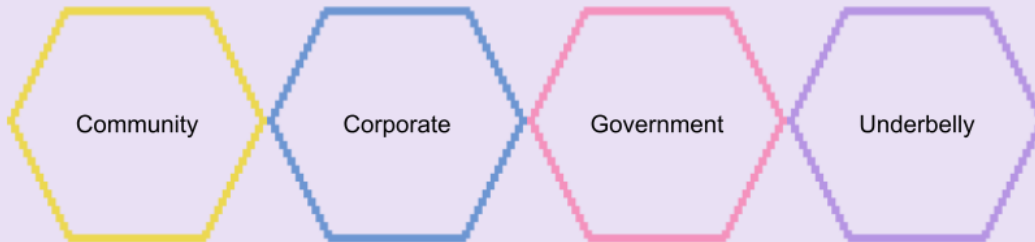

Factions

Purradise City has 16 unique factions from players to choose from to play as.

- MONEY factions are yellow-themed.
- MATERIAL factions are purple-themed.
- LABOR factions are blue-themed.
- PUBLIC RELATIONS factions are pink-themed.

Factions are drawn in a lined painted style. Features such as clothes, hair, fur, and faces are kept low-detail. Shading is simplistic and doesn't imply harsh light sources.

Characters use a blend of realistic features (such as 5-fingered hands and defined musculature) and cartoonish proportions (large heads, eyes, and ears).

The color palette and themes are expressed mainly through clothing. Skin tones and fur colors are all natural. Hair color and eye color can be either natural or unnatural.

Character illustrations are 840x1080px, 300 DPI.



Union

The Union faction was the first character we designed. She was designed to be simply and scrappy, with more muscle than most of the characters and short hair for a tomboyish look. We wanted her to look confident, but also like the average worker - the kind of person who is perfect for leading a union. To really sell this look, we decided to give her a bobbed tail - was she born this way, or did she lose it in a fight? That is up to the player to decide.



Church

Early in development we decided it would be funny if we had one character who was just a cat. After deliberation, we concluded the funniest option would be the Church faction. We never made any final decisions on what they worship, or what the religious culture is like - but we do know the citizens of Purradise City trust their religious leadership to what appears to be an ordinary talking cat. He is modeled after the quintessential orange cat, which may or may not imply him to be stupid underneath the ornamentation. His outfit is based off of those of Catholic popes, leading to the affectionate nickname "pope cat".



Bankers

The Banker faction was the second one we designed. We really wanted to capture the most common type of catboy seen in anime and other similar medias. To that end, he is skinny, groomed, and has an aura of smugness around him. We decided he would be perfect for the Banker faction since he already looked like such a rich boy. His cat parts are even modeled after the incredibly fancy Oriental Shorthair breed, putting him in a level of prestige above the other randombred cat coats featured in the game.



Underground Trade

We knew from the beginning that we wanted some of the factions to have an aura of mystery and darkness surrounding them. We thought it would be funny to use this idea of an underground black market beneath Purradise City, run by a man who looks like he's never gotten his paws dirty once in his life. His appearance is, of course, supposed to evoke that of a classic vampire. We added the features of a black cat on top of this to help sell just how shady this guy is. What exactly is it that he and his men deal in? Some things are better left unknown.



Mining & Lumber

During early development, a team member for whatever reason said the phrase "gas mask cat", and everyone found this such a fascinating image that we had to add it to the game. We didn't even consider what faction would wear a gas mask until after the character was designed. It seems this person must work in the depths of Purradise Cities mines where toxic gas flows. Not much is known about them, but the tradespeople of the city all seem to trust their leadership. This character was meant to be a truly mysterious figure amongst the beautiful people of Purradise City, someone to stand out with their monochromatic color scheme and unseen face.



Science

The Science faction is based on, well, cartoon scientists. With the lab coat, round, thick glasses, and folder of mysterious papers it's undeniable this individual works in *some* kind of scientific field. This character is unique, being one of the few factions based on a specific cat breed, that being the sphinx cat. We decided to blend the spotted skin colors of sphinxes with the human skin condition vitiligo, creating a character who looks more cat than human. They probably have skin conditions you've never even heard of but, hey, maybe that's what they specialize in?



Cult

The Cult faction is the fan favorite of the team, and the character who went through the least revisions. She's stern and confident, but small and beautiful. She's the kind of person to have massively built bodyguards, but still be able to get them on their knees with a single command. Similarly to the Church, we never really decided what this cult worships. All we know is that it is in direct opposition of the Church, making this lady mortal enemies with a cat. She is, of course, a black cat - because what would be more fitting for a character so dark and sinister?



Education

The most tired member of the cast is the Education faction. The lines beneath her eyes clue you in to the fact that she's been at this for *years*, and the antics of small children could never phase her anymore. All she wants is what's best for the children of Purradise City, and she's ready to use her years of authoritative training to get the city to back her up. We used round shapes and soft features to make her look motherly and kind. Her hairstyle, too, was specifically chosen to harken back to an old anime trope that some may recognise.



Art

The Art faction is the artist's fursona. No, really, that's why he looks like this. But like any good artist, he's scrawny, weak-wristed, and dresses like an eccentric uncle. There's something mischievous in that smile... maybe he's plotting to use your likeness in his next masterpiece. Out of all the characters in Purradise City, this one looks least like the leader of something, which is strangely fitting for the Art faction. Communities of artists are often built on mutual respect and the sharing of tips and tricks, so maybe he was just chosen to represent a larger collective. Or maybe he's just crazy.



Mafia

Like the Science faction, there's really nothing else this guy could be but the Mafia leader. He's got the bulk, the bowler hat, and the moustache to prove it. We really enjoyed pushing the limits of our art style for this character. His proportions are the most extreme of the cast, but he still fits in well with the other characters. We don't really know what it is Purradise City's mafia really does, or why they're even publicly campaigning - don't they already run the place behind the scenes? Whatever it is, this baby-faced mob boss has got to have something plotted behind the scenes.



Healthcare

The Healthcare faction was another faction drawn without a specific idea in mind. But once he was on the paper, we knew he had to be included somehow. Common comments include, "what reason does a healthcare professional have to look so hot?" Considering he's campaigning for control of Purradise City, maybe there's more to him than *just* being a doctor. Although, if you took away the stethoscope, you probably wouldn't recognise him anyway.



Fishing

Fish is the food that makes up the majority of the average Purradise City citizen's diet, so it only makes sense for the Fishing faction to be vying for power. This girl seems to really know her stuff - prepared for any fishing occasion with pockets full of hooks and bait. This fisher-woman was designed to both fit into her profession, but also look like a younger woman whose really passionate about what she does. The fishhook earring clearly implies she sees fishing as an aesthetic in addition to her job.



Music

There's no beating around the bush - the Music faction was designed to look like an early 2000s emo teenager. Except he's an adult. So he toned it down a bit. He probably doesn't even play emo music - but you won't find out until you give him a chance to perform. Similarly to the art faction, it seems a little unclear what his and his musician friends' motivations are to control Purradise City. If you let him win, things just may get a bit more gloomy around the place. Entirely unrelated, but this particular character's coat colour is based on the artist's recently deceased cat, who would probably have hated being immortalised as an eboy.



Mercenaries

Purradise City is not at war - at least, not that we know of - so why is there a prevalent faction of Mercenaries? You know, just in case. This woman looks strong and intimidating, and has clearly been in quite a few battles with the scars to show for it. Her military green vest implies a past of service, but she doesn't care to answer those kinds of questions. She's muscle for hire, and it's possible someone hired her to run for Purradise City's mayor... Or maybe she decided she'd be better off making decisions for herself.



Corporate

Corporations already run the world, but the Corporate faction wants more. This woman means business, and she's not afraid to tell you or your manager about all her problems. She thinks she can fix all the world's problems through math and manpower, but neglects to think about the fact that people are people. But she *is* very good at her job. What that job is, no one's really sure, since she seems to always be behind her cubicle sipping on a StarPaws drink. Soft colours were intentionally used in her design to not make her *too* intimidating, but her features were kept sharp and thin to resemble the classic secretary type of character.



Farming

The Farming faction was the last character we designed. Originally, he was much more of a grumpy old man than he is now. Now, he looks like the kind of guy who would love to share you all the crazy stories from his life over a can of nice cold beer. He's a mish mash of patterns with his plaid flannel shirt and salt-and-pepper beard, but that's just because he cares more for function over fashion. He wakes up early and goes to bed late, and would have all of Purradise City on his schedule if he could. But wait... what do cat's even farm anyway?



Cards

Cards in Purradise City contain multiple assets.

The card bases are currently done in a blocked-out style with no shading, although this may potentially be changed.

Each card features a unique painting as its representational art. These paintings use a lineless style similar to that of the logos. They are simple illustrations featuring cat-themed conceptualisations of the cards effects.

Cards also contain the icons covered before.

Card illustrations are 640x480px, 300 DPI.

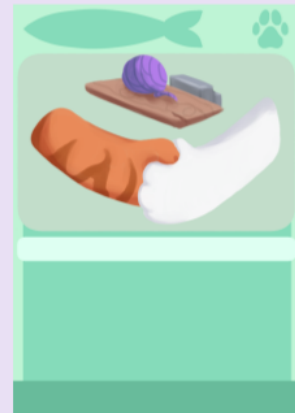

Cards



Cards



Cards



there was a duplicate here im too lazy to fix it rn



Cards

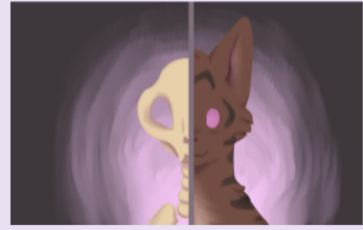

Cards

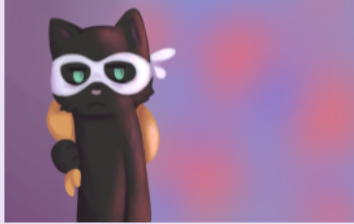

Cards

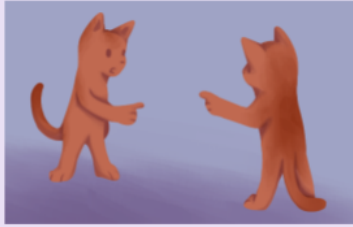
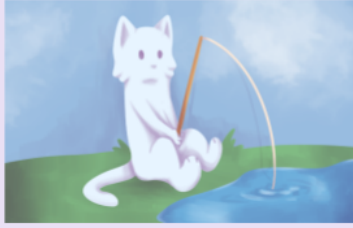

Cards



Cards

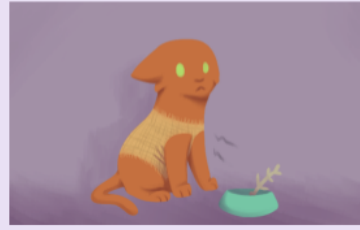

Cards

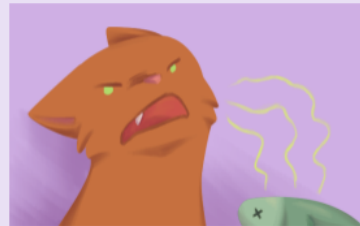

Cards

