

MHR-BKLN-44



The Implementation of a Crosswalk Improvement Plan for the Town of Brookline, MA

An Interdisciplinary Qualifying Project
Submitted to the faculty of
Worcester Polytechnic Institute
in partial fulfillment of the requirements for the
Degree of Bachelor of Science

Submitted By:

Matthew Cichon
Elliott Eno
Kevin Mullins
Michael Ryan

Sponsoring Agency:

The Town of Brookline Department of Public Works

Submitted To:

Project Advisors:

Hossein Hakim
Malcolm Ray

On-Site Liaisons:

David Friend
333 Washington Street
Brookline, MA 02445

Date: May 29, 2005

Acknowledgements

We would like to acknowledge and thank the following individuals for their invaluable contributions to this project. First and foremost we would like to thank our liaison, Mr. David Friend, Assistant Director for Transportation at the Brookline Department of Public Works, who made himself available to us at all times and helped to get us any and all supplies and contacts needed to conduct the project and was a constant voice of encouragement. Thanks to Mr. Peter Ditto, Director of Engineering and Transportation Division, Mr. Lester Gerry, Director of Highway and Sanitation Division, and all of the members of the Transportation Board for their interest in our project. Thanks to Mr. Feargal O'Regan, Traffic Systems Supervisor of the Highway and Sanitation Division, for his extensive knowledge of the marking materials used throughout the town and the free samples. Special thanks to Mr. Charles Barry, Senior Civil Engineer, for taking the time to sit down with us and for providing the design specifications currently being used. Thanks to Ms. Parvaneh Kossari for her help with the GIS software and for getting us the map layers we needed to carry out our work. Thanks to Mr. Uttam Nirmal, Mr. Robert Kefalas, and Mr. Christopher Hobbick, and the rest of the Transportation Department staff for making room for us in a crowded office and all your help along the way. Thanks to Mr. Peter Lagerwey of the City of Seattle, WA Department of Transportation for taking the time to send us the full version of his published study. Finally, thank you to our advisors, Professors Malcolm Ray, Hussein Hakim, and Fabio Carrera for their constant guidance, support, and help throughout this project. Without the support of these outstanding people this project would not have been possible. Thank you all.

Abstract

The aim of this project was to create an efficient plan and comprehensive policy for the maintenance of pedestrian crosswalks in the city of Brookline, Massachusetts. Crosswalks were inventoried and the results placed into a database that will assist the Brookline Department of Public Works by enabling fast and efficient queries of existing crosswalk characteristics. A comprehensive crosswalk policy was researched and proposed, and the cost of the implementation as well as continued maintenance estimated.

Executive Summary

The Brookline Department of Public Works is responsible for the installation and maintenance of all pedestrian crosswalks in the town of Brookline, Massachusetts. A well-documented plan for efficient installation and maintenance of crosswalk markings is currently needed to ensure cost effective practices and standards. The goal of this project is to meet this need by developing a maintenance plan along with a comprehensive policy for the design and installation of pedestrian crosswalks, which will eliminate wasteful spending, produce comprehensive standards, and ultimately improve the quality and safety of pedestrian crossings throughout Brookline.

In order to get a full understanding of the magnitude of this project, a map of all existing crosswalks was made using the Brookline GIS system. This map will be a useful tool for the DPW as it allows easy access to information when linked to a database through a user-friendly interface. The map layer can also display certain attributes such as marking condition, marking pattern, and marking material for each crosswalk. The creation of this map revealed the total number and exact locations of the 585 Brookline crosswalks.

Aerial photographs were used to customize data collection forms for each location. These forms allowed for the collection of various kinds of data on all crosswalks present at a single location or intersection. Data was collected on the condition, marking pattern, material used, signage present, physical dimensions, and special treatments for each crosswalk. This information creates an accurate profile of crosswalk characteristics throughout the town, but also allows of the analysis of specific crossings. A total of 393 crosswalks were inventoried in this manner during almost three weeks of fieldwork.

The enormous amount of data gathered during the inventory was archived in a database. The database was designed to be as user friendly as possible, and to be updateable so that a complete, accurate, and up to date inventory of crosswalks can be maintained. Database forms allow for the easy entry of information and also for changes to be made to existing records. The database also proved to be a powerful tool for analysis of the inventoried crosswalks. In addition to calculating the total amount of

crosswalk inventoried to be over 103,500 linear feet (19.6 miles), it was found that 227 (58%) of the 393 crosswalks inventoried were in “Poor” condition. This demonstrates the need for increased maintenance efficiency and the usefulness of having a complete crosswalk inventory.

To develop a maintenance plan that would improve efficiency, the advantages and disadvantages of various marking methods and materials were explored. Price quotes were obtained from two contractors and one manufacturer for various materials. It was calculated that the cost of upgrading all crosswalks not in “Excellent” condition with the least expensive and least durable marking material (chlorinated paint) would cost the town \$33,276. To upgrade these locations with the most durable material (inlayed tape) would require \$537,171. The current budget for such work is \$40,000 and includes sections of the town not inventoried in this study, as well as all other pavement markings throughout the entire town. The project team recommends that the town double this budget to allow for the upgrade of all crosswalks with paint, and that a financial plan be developed to allow for the long term installation of inlayed tape. As Brookline uses five and ten year budget cycles, the proposed plan called for \$107,434/yr for five years, or \$53,717/yr for ten years. Inlayed tape must be installed during roadway resurfacing or reconstruction, and Brookline officials estimated that they resurface a mile or two of roadway each year. The ten-year fiscal plan would thus make plenty of funds available for inlayed tape installation as roadways were repaired and reconstructed, while allowing for the continued maintenance of existing crosswalks with paint.

A comprehensive policy for the design, maintenance, and installation of crosswalks was also developed through a review of literature and direct observation of existing crosswalks within Brookline. The goal of this policy was to create specific and uniform standards that were not only safe, but efficient and cost effective as well. Crosswalks on controlled approaches were determined to require only the standard marking pattern of two perpendicular bars. Crosswalks on uncontrolled approaches, or approaches without a stop sign or traffic signal, were determined to require a ladder marking pattern for increased visibility.

A review of the inventory allowed the Project Team to determine that ladder, block, and zebra marking patterns were currently being used at 96 approaches controlled

by a traffic signal. It was calculated that renovating these locations with a standard marking pattern would remove over 15,000 linear feet of marking material and save the town a minimum of \$5,000 dollars assuming the use of paint as the marking material. Over \$86,000 worth of future inlayed tape marking material could be saved by this simple change.

The policy also set guidelines for the placement, color, and dimensions of crosswalks, as well as standardized the practices at T-type intersections and mid-block locations. Analysis of the collected data revealed the location of nine T intersections with a redundant crossing as determined by the recommended policy. Elimination of these redundant crossings would result in over \$700 of marking paint saved during each maintenance cycle.

In addition to the specifications on the dimensions and type of crosswalks, the proposed policy also set guidelines on how and when to maintenance and install crosswalks at given locations. It is recommended that locations which do not meet the new policy be renovated as the roadway is resurfaced, or when the condition is poor enough to allow for a clean marking pattern to be installed. Any new crosswalks should meet all of the guidelines set for dimensions, material, and marking pattern. Crosswalks were divided amongst three zone types and minimum conditions set for each zone to define when crosswalks require maintenance.

The first established zone is the quarter mile surrounding each of the town's schools. Crosswalks within these school zones are to be kept in "Good" or better condition, as these are areas of high traffic volumes. It is also imperative that the markings at these crosswalks be kept visible to ensure that children are directed to safe crossing locations. Crosswalks within commercial zones, or adjacent to lots zoned as such should likewise be kept in "Good" or better condition due to the high traffic volumes. Crosswalks in residentially zoned areas should be "Fair" or better condition because of lower pedestrian and vehicular volumes. The Project Team recommends that "Poor" crosswalks within school zones be upgraded first, followed by those in commercial areas, and that crosswalks within residential zones be upgraded as funds become available.

Table of Contents

THE IMPLEMENTATION OF A CROSSWALK IMPROVEMENT PLAN FOR THE TOWN OF BROOKLINE, MA	I
ACKNOWLEDGEMENTS.....	II
ABSTRACT.....	III
EXECUTIVE SUMMARY	IV
TABLE OF FIGURES.....	VIII
TABLE OF TABLES.....	IX
TABLE OF TABLES.....	IX
1 INTRODUCTION.....	1
2 BACKGROUND.....	4
3.1 GIS Inventory - Locating Marked Crosswalks in Brookline.....	16
3.2 Design of the Data Form.....	17
3.3 Field Inventory of Marked Crosswalks.....	19
3.4 Condition Ranking.....	21
3.5 Database Development.....	22
4 RESULTS AND ANALYSIS.....	26
5 POLICY DISCUSSION.....	39
5.1 Crosswalk Type and Specifications.....	39
5.2 Signage.....	41
5.3 Crosswalk Location.....	42
5.4 Crosswalk Maintenance.....	46
5.5 Maintenance Intervals.....	48
5.6 Marking Materials.....	50
5.7 Crosswalk Treatments.....	51
6. CONCLUSIONS.....	53
7. BIBLIOGRAPHY.....	54
APPENDIX A: MASS HIGHWAY DIRECTIVE.....	57
APPENDIX B: DATA COLLECTION FORMS.....	58
APPENDIX C: T INTERSECTIONS.....	60
APPENDIX D: SIGNALIZED INTERSECTIONS.....	61
APPENDIX E: SCHOOL ZONES.....	62
APPENDIX F: PATTERN MAP.....	63
APPENDIX G: CONDITION MAP.....	64

Table of Figures

Figure 1: Example Audio Beacons	1
Figure 2: Brookline Boarder Sign.....	1
Figure 3: 1999 Brookline Town Budget as % of Total.....	2
Figure 4: Double Threat Crosswalk Example.....	5
Figure 5: Mid-Block Crossing Example.....	5
Figure 6: Snowfall, salting, and plowing accelerate crosswalk deterioration.....	6
Figure 7: Number of People by Block in Brookline. Higher Population Indicated by Darker Red (Mapping Census 2000).	7
Figure 8: Elderly Bus Routes and Stops.	8
Figure 9: Brookline Bus Routes and T Lines.....	8
Figure 10: Curb Extensions,	9
Figure 11: A Raised Crosswalk	9
Figure 12: Countdown "DON'T WALK" Signal.....	10
Figure 13: Countdown "WALK" Signal.....	10
Figure 14: Installation of marked crosswalks warrant.....	14
Figure 15: Page 1 of the Aspinwall Ave Kent St Field Data Form	19
Figure 16: Excellent Condition.....	21
Figure 17: Good Condition	21
Figure 18: Fair Condition.....	21
Figure 19: Poor Condition	21
Figure 20: Intersection Database Form.....	23
Figure 21: Approach Database Form.....	24
Figure 22: Locations of all crosswalks found during the GIS inventory.....	26
Figure 23: Types of marking patterns found in Brookline	26
Figure 24: Percentage of each marking pattern in each condition.....	28
Figure 25: Crosswalk types and common marking materials.....	30
Figure 26: The locations of three T intersections with redundant crosswalks.....	34
Figure 27: Map showing crosswalks with a non-standard pattern at signalized approaches in the area of Harvard St at Beacon St.....	35
Figure 28: Crosswalk location and condition within quarter mile school zones.	38
Figure 29: Controlled Approach Striping Detail.	40
Figure 30: Uncontrolled Approach Striping Detail.	41
Figure 31: Pedestrian Warning Sign W11A-2 (Top) and Crossing Arrow Sign W16-7 (Bottom).....	41
Figure 32: Traffic Signal Controlled Intersection.....	42
Figure 33: Stop or Yield Controlled Approach.....	43
Figure 34: Uncontrolled Intersection Approach	44
Figure 35: Typical T Intersection	45
Figure 36: Mid-Block Crosswalk and Additional Signage.....	46
Figure 37: Example of an inlayed brick crosswalk.....	51

Table of Tables

Table 1: Number of crosswalks inventoried that fall into the given subclasses of condition, material, and type.....	27
Table 2: Condition, Type and Quantity of Crosswalks in linear feet of marking.....	27
Table 3: The percentage of each crosswalk type in each of the four conditions.	28
Table 4: Total amount of each marking material used for each crosswalk type. Values given are in linear feet.....	29
Table 5: Price quotes (\$/L.F.) for cost of materials received from two contracting firms, and also from a manufacturer of tapes (3M).....	31
Table 6: Cost of installation by contractor for each pattern type and material. Values based on the average dimensions of Brookline crosswalks.	31
Table 7: Cost estimates for the upgrade of all crosswalks in a given condition to excellent condition by material.	32
Table 8: Time in years required for maintenance of inventoried crosswalks under the current budget by condition and material used.	33
Table 9: Dollars required per year to purchase the amount of tape material needed to upgrade all crosswalks in the given condition directly from the manufacturer 3M.	33
Table 10: The estimated savings of removing a redundant crosswalk at a T intersection.	34
Table 11: The amount of material (L.F.) in use at signalized intersections broken down by pattern and the material required for a standard pattern at the same locations.....	36
Table 12: Dollars required to maintain the “extra” L.F. of ladder, block, and zebra patterns at signalized intersections by material.	36
Table 13: A comparison of the cost of 3M tape material purchased from the manufacturer and contractor, and the number of hours or Highway Department staff can be paid for with the difference.	37
Table 14: Marking material effective lifetime expectancies.....	48
Table 15: Materials costs and estimated durability.....	50

1 Introduction

According to the U.S. Department of Transportation Federal Highway Administration, 6,000 pedestrians are killed and 90,000 injured every year on U.S. roadways¹. Twenty-nine percent of all pedestrian fatalities are the result of improper crossing of roadways or intersections². This figure suggests the need for more accessible crosswalks along with sufficient signage. The disabled community is disproportionately affected by the shortcomings of the current system. For instance, not all crosswalks are equipped with ramps (Figure 1) and or audio beacons (Figure 2) to assist with crossing. The passage of legislation, including the Americans with Disabilities Act, and increased interest among communities to improve the maintenance system represent some efforts being made to solve this problem. The maintenance of a cost effective crosswalk consists of many details, including painting, redesign/construction, signage, and ramp placement.

The Town of Brookline, MA is one municipality considering improvements to their current pedestrian infrastructure. The town, a suburb of Boston, contains over 100 miles of roadway containing 695 intersections, and a population of over 57,000. Boston's Green Line runs through Brookline to Boston College, and this convenient method of transportation throughout Boston increases pedestrian traffic within the town. These factors make the safe flow of pedestrian traffic through the town, and thus the adequate maintenance of the town's crosswalks necessary.

In the fall of 2003 the Brookline DPW implemented a project designed to improve safety on certain streets. The projects resulted in the construction of several curb extensions and the installation of new pedestrian crossings and bicycle lanes throughout



Figure 1: Example Audio Beacons



Figure 2: Brookline Boarder Sign

¹ TFHRC www.tfhrc.gov/safety/pedbike/pedbike.htm

² HTSMCT Online. "Pedestrian Safety." www.aahp.org/links/NHTSA_Site/pedestrian.html

the town. Some of the intersections in the town have been reconstructed and curb extensions/safe crossings have been made. In addition to these improvements, the walkBoston organization recently participated in a redesign of Beacon Street to improve pedestrian safety³. The Brookline police department is also responsible for some daily duties including; providing for pedestrian safety programs especially designed to assist the elderly crossing streets. The total town budget in 1999 was \$126,132,226. Of the \$8,471,378 allotted towards the Department of Public Works, \$2,917,086 was devoted to highway work (Figure 5).⁴ The maintenance of sidewalks and crosswalks was included in this figure. The Highway Department also recently finished a study of roadway marking materials, though the results of this study have yet to be made available.

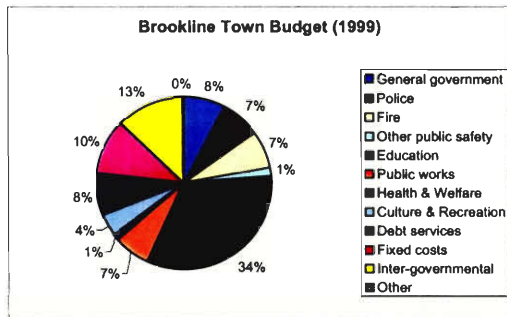

Figure 3: 1999 Brookline Town Budget as % of Total

Brookline’s neighbor to the north, Cambridge, has recently begun a comprehensive overhaul of its pedestrian crossing network which serves as an example of how cities around the nation could go about making improvements. Cambridge has outlined a few key features including; Curb extensions, raised crosswalks, improved crosswalk markings, and countdown signals⁵.

It is clear that Brookline has made a large investment with respect to improving pedestrian safety measures, and to protect this investment the town must now insure the improvement of their maintenance practices. Brookline requires a better organizational tool to allow the pooling of all data regarding the location and condition of existing marked crosswalks. A database of such information would facilitate improvements and quicken the design process of new crossings. The large number of crosswalk designs used throughout the town creates public confusion as to the purpose of each crosswalk. In addition, a comprehensive policy or decision-making process regarding the maintenance

³ WalkBoston Online. <http://www.walkboston.org/who.htm>

⁴ <http://yourtown.boston.com/town/brookline/finance.shtml>

⁵ The Department of Cambridge Community Development Online “Crosswalk Safety Improvement Program” http://www.cambridgema.gov/~CDD/et/ped/prog/ped_xwalk.html

and installation of crosswalks would improve design consistency and maintenance efficiency.

This project aims to complete an inventory of all-important information about crosswalks in Brookline by first hand observation throughout the city, which will allow for the creation of a comprehensive crosswalk policy that will improve maintenance practices. This inventory will be used to construct a database and organize all the information so that it is easily accessible to those who need it and effortlessly updated in the future. The information gathered will allow for the evaluation of existing crosswalk conditions and the findings of this inventory to be easily presented to the Transportation Board and other town officials. Feedback from this meeting will then allow the team to develop a new, comprehensive, crosswalk policy. This new policy will considerably expedite the process of maintaining or replacing crosswalks in Brookline. The goal is to create a policy that is based totally on need and will not be political in nature.

Going hand in hand with both the new policy and the database will be the development of a maintenance plan and cost estimates. This plan allows for universalizing the process of maintaining and installing crosswalks. This plan will allow the DPW to focus on completing crosswalk projects using a standardized approach rather than having to first determine the specific details of each case. It is expected that this contribution to the City of Brookline will assist them in making great strides to better efficiency and safety.

2 Background

In 2002, more than 4,000 pedestrians were killed and 75,000 injured throughout the country.⁶ Among the major advocacy groups supporting the improvement of public roads and pedestrian safety are “The Partnership for a Walkable America” (PWA) and the “Advocates for Highway and Auto Safety”. Each of these groups supports federal legislation promoting the proper maintenance and safety of crosswalks. Several nationwide research groups that are also contributing are the “Transportation Research Board” (TRB) and the “US State and Federal Bicycle and Pedestrian Coordinators”.

The major advocacy groups all support pedestrian safety in their own unique ways. The PWA, for example, is a non-profit organization concerned with improving the conditions of walking in America, along with increasing the number of Americans who can walk regularly. This group looks out for the general welfare of pedestrians, particularly with concerns for people at crosswalks and dangerous intersections. The “Advocates for Highway and Auto Safety” takes a slightly different approach to safety, and concentrate primarily on making America’s roads safer. The TRB and the “US State and Federal Bicycle and Pedestrian Coordinators” are quasi-governmental organizations that are primarily devoted to research, design, and construction, but support strict safety measures for pedestrians.

Despite several differences in the objectives, all of these organizations and advocacy groups were partly formed to improve the safety of pedestrians. Passed by the federal government in 1990 and through several amendments and additions, the “Americans with Disabilities Act” sets guidelines for accessibility to public places and establishments, along with commercial facilities to accommodate and help individuals with disabilities. The application of design, construction, and alteration of buildings, roadways, and other facilities are under the jurisdiction of these guidelines. In order to have effective safety for pedestrians crossing the street, proper maintenance must be practiced. The ADA supports this measure, as all public facilities including crosswalks, must meet certain requirements and standards.

⁶ www.tfhrc.gov/safety/pedbike/pedbike.htm

Roadway and crosswalk design often present problems in some communities. Among these problems is the “Double Threat” crosswalk that is created when two or more lanes of traffic are going in one direction. In this situation if the nearest lane driver stops for the pedestrian, then both the pedestrian and the driver in the far lane are blind to each other. Figure 4 clearly demonstrates how the white van obstructs the view of the pedestrian and makes it difficult for them to see a car approaching in the far lane. It is also clear that the white van in the near lane hides the pedestrians from the view of the oncoming motorist. There could easily be an accident if the driver and the pedestrian do not make eye contact. The design of this crosswalk system is often very dangerous, and extreme measures must be taken to prevent these types of accidents from occurring. For instance, if having a “Double Threat” crosswalk is unavoidable due the roadway situation, then better signage and prevention systems must be put in place, further increasing the costs of the crosswalk.



Figure 4: Double Threat Crosswalk Example

Another type of problem is the “Mid-Block Crossing”, where crosswalks are installed in areas far from intersections. This presents a major problem because drivers usually won’t slow down at these crossings and often do not pay attention to pedestrians crossing the streets at random locations along the road. Often these crosswalks are equipped with extra paint or signage on the approach to alert motorists of the crosswalk, as is the case in Figure 5. This type of crosswalk is usually reserved for schools or other high traffic areas such as shopping districts due to the added costs.



Figure 5: Mid-Block Crossing Example.

The actual cost of maintaining crosswalks is high in most areas of the country. This is partly due to several key problems associated with road maintenance and

construction. Highway designers and engineers usually select very high quality paint because it is often the most visible and long lasting. Even with top quality products, however, the paints used on roadways and crosswalks often fade and deteriorate quite easily as a result of weather conditions and traffic volumes. Painting is done at night to limit the disruption of traffic and the number of vehicles that pass over the wet paint. It is easier to close off a road and paint a crosswalk at night than during the day because of the lower traffic volumes. Painting at night leads to increased maintenance costs, as workers must be paid overtime to work during the nighttime hours.

Several other factors also influence maintenance costs and practices. Pavements often create complications in crosswalk construction and maintenance, as it costs towns and cities a great deal of money and time to build and repair damages. The disregard for the proper signage necessary at crosswalks and intersections is another complication. The widespread use of these signs is very costly and can weigh heavily on the budget of a town or city. If these signs are not properly maintained, however, they could create serious traffic and pedestrian conflicts at the intersections they are intended to make safer.

Weather conditions, construction disputes, and poor planning also lead to deteriorations in crosswalk maintenance and infrastructure (Figure 6). Communities with low budgets or budgets that are not geared towards road maintenance often suffer the most. If there is low support for projects within these communities then it is more likely that a road or crosswalk accident involving a pedestrian will occur. For example, Seattle, Washington is a major



Figure 6: Snowfall, salting, and plowing accelerate crosswalk deterioration.

American city, but only has a crosswalk improvement budget between \$100,000 and \$130,000. This allows the city to work on only a limited number of crosswalk projects per year⁷.

Brookline, MA is a community of 6.6 square miles and 57,000 people with a unique mixture of busy streets and rolling countryside, upscale shops, village pubs, gracious apartment buildings and large estates. Its major retail centers, like Coolidge Corner and Brookline Village, are bustling pedestrian-oriented shopping areas. In addition, Brookline boasts a wonderful parks and recreation system which is delightful for families, children, and visitors all year round. Along with offering both a city atmosphere and a feeling of being in the country, there is a wonderful mix of people in Brookline: elderly, minorities, and immigrants from many lands, young families and college students. This dense community of 8,000 per square mile requires that its streets and especially crosswalks be as well maintained as possible. Figure 9 shows the number of people per block throughout Brookline. It is clear that the town has both urban and residential areas.

The town's transportation system is adapted to its growth, as well as the need to move people to and from its neighboring city of Boston. The principal highways close by are State Routes 9 and 30 and U.S. Route 1. The Massachusetts Turnpike (Interstate Route 90) runs just north of the town boundary. The "T" (i.e. the subway) runs between Brookline and Boston quite conveniently. The MBTA subway service is available on the C (Cleveland Circle) and D (Riverside) branches of the Green Line. From Brookline Village, the travel time to Kenmore in Boston is six minutes and to the downtown

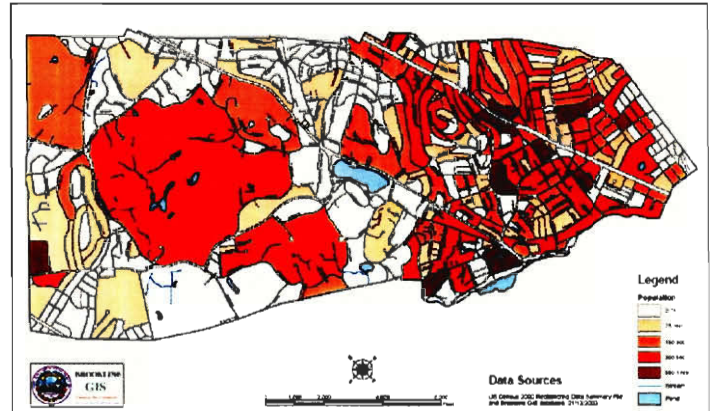

Figure 7: Number of People by Block in Brookline. Higher Population Indicated by Darker Red (Mapping Census 2000).

⁷ Hefferan, Jennifer R. and Peter Lagerwey. "The City of Seattle, WA, USA, crosswalk inventory and improvement plan." *ITE Journal (Institute of Transportation Engineers)*. 74, no. 1 (2004): 42-46.

Government Center station 19 minutes. Passenger rail service to Worcester, Springfield, Providence and points beyond are available on Amtrak in adjacent Boston.

Brookline is very accessible due to the fact that the town is a member of the Massachusetts Bay Transportation Authority (MBTA). Aside from the Greenline, the MBTA provides The Ride, a paratransit service for the elderly and disabled through the more densely populated regions of the town (Figure 10). Peter Pan bus lines also provide service to stops in Brookline every two hours during the week along its Boston to Worcester route. Figure 9 shows the various T lines and bus routes throughout the town.

Many studies and projects offer insight into possible solutions for pedestrian crosswalk and traffic planning problems. These studies range from overall pedestrian flow to the examination of individual pedestrian accidents at unprotected crosswalks, to comprehensive studies of the safety of marked versus unmarked crosswalks. A study was conducted in 1995 of the pedestrian flow throughout Hong Kong.⁸ The objective was to collect walking distance, speed, flow, and density data for various sections of the on-foot traffic network. The outcome of the data collection was proposed speed-flow-density relationships for indoor and outdoor walkways, signalized crosswalks, light rail transit crosswalks, and stairways. This study could apply to our study as increased efficiency in pedestrian movement would tend to increase safety and possibly even make maintenance easier.

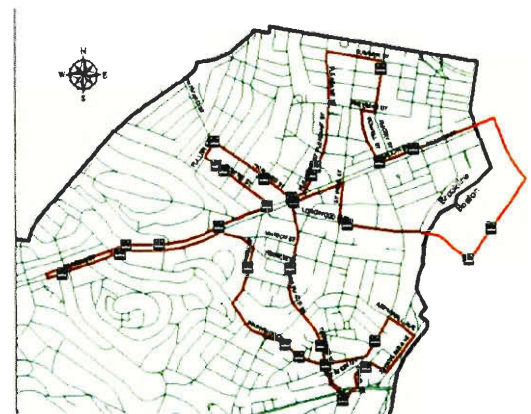

Figure 8: Elderly Bus Routes and Stops.

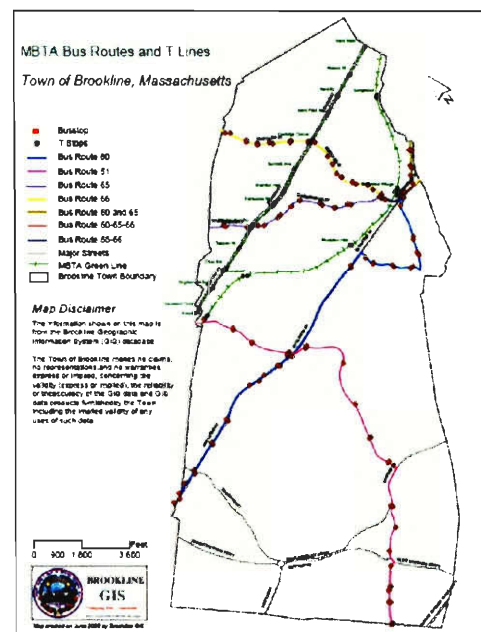

Figure 9: Brookline Bus Routes and T Lines.

⁸ Lam, WHK, Morrall, JF, and H. Ho. "Pedestrian flow characteristics of Hong Kong." Transportation Research Record. no. 1487 (1995): 56-62.

Perhaps more closely related to this project is a quantitative study conducted in Los Angeles, California to examine a random group of pedestrian accidents at unprotected intersections.⁹ The study was designed to determine the validity of current practices in Los Angeles, something that would be essential to justifying any proposed changes in a city's standard of implementing its pedestrian traffic network. The study involved 104 intersections where marked crosswalks have been removed on arterial streets due to street resurfacing from February 1982 through December 1991. As discussed in a separate section of this report, the City of Seattle, Washington completed a comprehensive inventory of marked crosswalks at uncontrolled locations.¹⁰ The inventory was then used primarily to identify crosswalks with safety problems and find ways to help pedestrians cross the street, rather than using the inventory to remove unsafe crosswalks. The result of this study was a plan for pedestrian safety improvements at marked crosswalks.

The city of Cambridge, Massachusetts is a very good example of what is currently being done around the country, in terms of what tactics are being utilized in the design and construction of safe and efficient crosswalks. The city recently completed a comprehensive overhaul of its pedestrian crossing network. Cambridge has outlined a few key features; i.e. curb extensions, raised crosswalks, improved crosswalk markings, and countdown signals.¹¹ Curb extensions (Figure 10), also known as chokers, slow

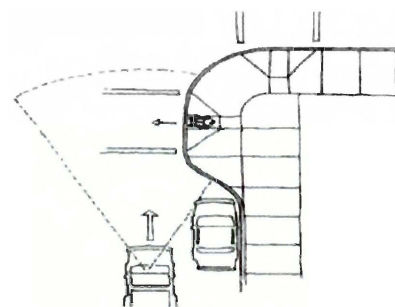

Figure 10: Curb Extensions,



Figure 11: A Raised Crosswalk

⁹ Jones, Thomas L., "Pedestrian accidents in marked and unmarked crosswalks: A quantitative study." *ITE Journal*. V 70, no. 9 (2000): 42-46.

¹⁰ Hefferan, Jennifer R. and Peter Lagerwey. "The City of Seattle, WA, USA, crosswalk inventory and improvement plan." *ITE Journal (Institute of Transportation Engineers)*. 74, no. 1 (2004): 42-46.

¹¹ The Department of Cambridge Community Development Online "Crosswalk Safety Improvement Program." http://www.cambridgema.gov/~CDD/et/ped/prog/ped_xwalk.html

traffic as it moves through intersections by slightly impeding turning vehicles. These extensions also prevent the view of the pedestrian and motorist from being obstructed by parked cars.

Raised crosswalks (Figure 11) slow on-coming traffic by acting as a speed bump. These devices are more desirable than ordinary speed bumps, as they are not as steeply inclined and allow vehicles to travel over them at higher speeds and reduce the likelihood of vehicle damage. They also put the crosswalk itself higher up in the view of motorists, which makes them more visible.

The final implemented feature of Cambridge's improved crosswalks was countdown signals. These signals have two phases, a "DON'T WALK" phase (Figure 12) and a "WALK" phase (Figure 13). The "DON'T WALK" phase tells pedestrians how long they have to wait while the "WALK" phase tells pedestrians how long they have to cross the street.

The Hefferan and Lagerwey study in Seattle began with clear definitions of, and delineations between crosswalk types, before making a complete inventory of uncontrolled Seattle crosswalks.¹² To date nothing of such scope has been attempted in the town of Brookline and this project would likely be the first major attempt made to replicate the Seattle study in Brookline.

The Seattle study also proved the usefulness of a crosswalk inventory as researchers used their data to propose a broad maintenance plan. A "piggyback" funding approach was developed under which the needed improvements were made in conjunction with larger projects. This enabled the city to incorporate the costs of the maintenance and renovation into the larger budgets, and in some cases simply direct funds from a larger budget to the more immediate problems of crosswalk maintenance. The ranking system used in the study allowed the city to rank the



Figure 12: Countdown "DON'T WALK" Signal.



Figure 13: Countdown "WALK" Signal.

¹² Hefferan, Jennifer R. and Peter Lagerwey. "The City of Seattle, WA, YSA, crosswalk inventory and improvement plan." *ITE Journal (Institute of Transportation Engineers)*. 74, no. 1 (2004): 42-46.

crosswalks with respect to need and fund those projects that were most necessary. By focusing their renovations and maintenance efforts on the locations most in need, the city was able to both improve safety conditions and optimize the impact of the investment. Brookline does not currently have such a system but could be expected to benefit from one in similar ways.

There currently exist some accepted standards and practices for pedestrian crosswalk design that will be used as a baseline for developing a general policy tailored specifically for Brookline. Perhaps the most widely used standard is the Federal Highway Administration's Manual on Uniform Traffic Control Devices (available on their website). The MUTCD is adopted under certain sections of federal law, and is the national standard to which all state and local laws and guidelines must conform. This guide is open to interpretation, however, and includes both regulations and suggestions. Local officials must still decide which suggestions or recommendations of the MUTCD they will adopt, and how best to conform to the requirements. This situation does not always achieve the goal of establishing uniform design practices, and this is the case in Brookline.

Section 3B.17 of the MUTCD establishes the following standard for pedestrian crosswalks:

“When crosswalk lines are used, they shall consist of solid white lines that mark the crosswalk. They shall not be less than 150mm (6 in) nor greater than 600 mm (24 in) in width.”¹³

The presence of such flexibility in crosswalk design is often thought to be a positive aspect, though in actuality it can create several problems. Though the freedom allows engineers to design crosswalks for unique or unconventional circumstance, it also fails to establish a real standard. The requirements of the MUTCD are minimal, and thus result in more than one crosswalk treatment being acceptable at a given intersection. This leaves the crosswalk design open to interpretation, and as is the case in Brookline, multiple crosswalk treatments being employed at similar intersections or even the same intersection. This is not the standardized result needed to maintain design consistency and

¹³ <http://mutcd.fhwa.dot.gov/>

maintenance efficiency. A more structured policy is clearly needed to achieve these goals.

The Vermont Agency of Transportation has established a substantial crosswalk policy to ensure crossing treatments are consistent throughout the state of Vermont. The document entitled Guideline for the Installation of Crosswalk Markings and Pedestrian Signing at Marked and Unmarked Crossings is intended to supplement the provisions of the MUTCD.¹⁴ The document refers to the MUTCD standards and suggested guidelines, and then determines which of the suggested provisions are to be used for a given situation. In some cases the document also contains provisions not contained within the MUTCD.

Other municipalities have developed warrants to help determine the need for and type of crosswalk treatment to be used at a given location. One such example is the City of Palo Alto. The warrant used by this municipality (Figure 14) employs a point system to determine the need for a crosswalk treatment. Each aspect of the general location, the average daily traffic, and the pedestrian volumes receives a certain amount of appropriately weighted points. For a crosswalk to be installed, the location must generate a minimum number of these points.

The Massachusetts Highway Department is the body responsible for roadway markings on all of Massachusetts' state highway markings. Boylston St (Route 9) runs through southern Brookline and is a state highway under MHD jurisdiction. While Brookline does not administer any of the crosswalk locations along this roadway, the practices of Mass Highway must be taken into account if the goal of consistent crosswalk marking throughout the town is to be met. According to Mass Highway Engineering Directive E-96-001 (Appendix A), the following standards for crosswalk markings have been established.¹⁵

- 1) The standard crosswalk marking used on the state highway system shall be the 'Type A' marking as detailed in Figure 3 – 14 of the MUTCD.
- 2) The standard line width of the markings shall be three hundred (300) millimeters.
- 3) The width between crosswalk lines should be no less than two (2) meters.

¹⁴ <http://www.aot.state.vt.us/progdev/Documents/TrafficOperations/Crosswalk%20Guidelines%202004.pdf>

¹⁵ http://www.mhd.state.ma.us/downloads/engineeringDirectives/1996/E_96_001.pdf

- 4) Where provided, stop lines should be placed no less than 1.25 (one and one-quarter) meters behind an adjacent crosswalk line.
- 5) Isolated crosswalks shall not be installed in areas with a sight distance less than the minimum required under Table 3.11 STOPPING SIGHT DISTANCE in the MHD Highway Design Manual.

Section 9.6.1 of the current version of the MHD Highway Design Manual refers the reader to the guidelines of the MUTCD for crosswalk design guidance.¹⁶

It is a goal of this study to propose a set of guidelines to be adopted by the Brookline Transportation Board as a comprehensive crosswalk policy for the town. There currently is no written document describing the town's crosswalk policy that citizens or officials can refer to. The actions taken with respect to the installation and maintenance of the town's crosswalks is largely left to the discretion of town officials in the Transportation and Highway Departments. Town Engineers have developed a set of guidelines for crosswalk installation currently being used to replace crosswalks during roadway renovation. These unofficial specifications can be found in Figure 29 and Figure 30 in Section 5.1 of this report.

¹⁶ <http://166.90.180.162/mhd/downloads/manuals/design.pdf>

The following guidelines for installation of crosswalks at uncontrolled intersections were adopted by the Palo Alto City Council on December 18, 2000

City of Palo Alto		
Warrants for Marked Crosswalk at Uncontrolled Intersections		
(A) Basic Warrants		
(i) Pedestrian Volume Warrant		
Pedestrian volume at proposed crosswalks should be more than 20 pedestrians per hour (pph) during the peak pedestrian hour or 15 pph for each of 4 hours.		
(ii) Approach Speed Warrant		
The 85 th percentile speed at the proposed marked crosswalk locations should be less than 40 mph.		
(iii) Visibility Warrant		
The unrestricted view for motorists to the proposed marked crosswalk site should have a distance greater than 200 feet approaching from each direction. This will be a special concern at sites with grades, curves and other potential significant sight restrictive features.		
(iv) Illumination Warrant		
Proposed marked crosswalk site must have adequate street lighting near the crosswalk in existence or scheduled for installation prior to the installation of the marked crosswalk.		
(B) Warrant Point System of Criteria (need to compile at least 16 points)		
(j) Pedestrian Volume Warrant		
	Point Assignment	
Criterion	Pedestrian Total	Points
The total number of pedestrians crossing the street under the study during the peak pedestrian hour. This includes pedestrian volumes at both crosswalks. Crosswalk will not be installed where the ped volume is less than 10.	0-20	0
	21-40	2
	41-60	4
	61-90	6
	91-100	8
	Over 100	10
	Maximum	10
(k) General Conditions Warrant		Points
(a) Will clarify and define pedestrian routes across complex intersections		2
(b) Will channelize pedestrians into a significantly shorter route		2
(c) Will position pedestrian to be seen better by motorists		2
(d) Will position and ensure pedestrian meets fewer vehicles		2
(l) Gap Time Warrant		
The number of unimpeded vehicle time gaps equal to or exceeding the required pedestrian crossings time in an average five-minute period during the peak vehicle hour	Ave. # gaps per 5 min. period	Points
	0 - 0.99	10
	1 - 1.99	8
	2 - 2.99	6
	3 - 3.99	4
	4 - 4.99	2
5 or more	0	
	Maximum	10
Computations		
(1) Pedestrian Crossing Time = street width from curb-to-curb divided by 4 feet per second		
(2) Average number of gaps per five-minute period = Total usable gap time in seconds divided by pedestrian crossing time multiply by 12.		
Note: All the warrants need to be met for installation of marked crosswalks at uncontrolled intersections.		

Figure 14: Installation of marked crosswalks warrant.

3 Methodology

This project was intended to assist the Brookline Department of Public Works in ensuring cost-effective maintenance practices by creating a universal and consistent policy for the maintenance and installation of modern pedestrian crosswalks. The team created a database of current crosswalk locations as well as specifications for the materials to be used, signs to be posted, and the design of the crosswalks and ramps as well as their construction.

This study included all marked crosswalks within the town of Brookline, MA. For the purposes of the study a marked crosswalk was defined as any location legally marked as such, or any location having signage indicating to both pedestrians and motorists that pedestrians can reasonably be expected to cross at that location. The Project Team limited the study to those locations completely within the Brookline city limits. Locations outside of this legal boundary were not included. Locations crossing this legal boundary were also not included. In addition, locations at intersections along Boylston St. (Rt. 9) and also Beacon St. were also excluded. Boylston St. is under the jurisdiction of the Massachusetts Highway Department, and this body is responsible for the maintenance of crosswalks along the roadway. Beacon St. was excluded because the complete reconstruction of the roadway is planned to begin this summer, soon after the completion of this study.

The following set of primary objectives was identified as essential to completing the goals of this project:

1. Inventory crosswalk characteristics throughout Brookline.
2. Rate the condition of each crosswalk.
3. Correlate condition and crosswalk characteristics through regression analysis.
4. Produce cost estimates and maintenance schedule.

These objectives were achieved through a variety of methods to be described in the following sections:

- Section 3.1 includes the procedures for locating and creating a GIS inventory of all marked crosswalks within Brookline, MA.
- Section 3.2 describes the field forms and methods used to generate them.

- Section 3.3 discusses the procedures used at each location during the field inventory.
- Section 3.4 includes a description of the procedures used to rank crosswalk conditions.
- Section 3.5 describes the design of the information database.

3.1 GIS Inventory - Locating Marked Crosswalks in Brookline

The first objective of the project was to develop a comprehensive inventory of all marked crosswalk locations in Brookline. A legal crosswalk exists where two streets intersect or, in the absence of an intersection, where a crosswalk is designated with markings. Marked crosswalks alert drivers to locations where pedestrians can be expected and show pedestrians a preferred place to cross. Crosswalks are often marked in locations controlled by traffic signals or stop signs (i.e., a called a controlled location) or in locations where traffic is not controlled by signals or stop signs (i.e., called uncontrolled locations).

Before a field inventory of crosswalk characteristics could be taken, the crosswalks first had to be located. Brookline possessed no data on the number or location of the marked crosswalks within the town. The use of GIS software was determined to be the quickest way of locating marked crosswalks. Aerial photographs of the town were used to trace visible crosswalks to from a new crosswalk GIS layer.

Each crosswalk created was given a unique identification code, consisting of the names of the streets forming the intersection where the crosswalk is located as well as a number corresponding to the specific approach. The street names were arranged according to the existing format used previously by the Brookline GIS Department to code the intersection identifications. Approaches were numbered starting with one at the northernmost approach and proceeding clockwise around the intersection in the aerial photo. Each approach in the photo is numbered, whether there is a crosswalk there or not. Midblock crossings were identified first by the name of the street they crossed, and then by the names of streets forming the nearest bordering intersections. This code enables the specific geographic location to be determined without the use of GIS software should that be necessary.

The aerial photos available on the Brookline GIS servers were several years old, and it is possible that not all of the currently existing crosswalks were visible. In an attempt to correct for this error, the work orders for any crosswalk installations or replacement were requested, and any crosswalks not on the GIS inventory encountered in the field were inventoried, and added to the GIS layer. Work orders for crosswalk maintenance do not exist, however, and thus there is no real way to ensure that all of the crosswalks within the town were included in the study. It would be possible to better determine this fact by a physical street-by-street drive through the town.

3.2 Design of the Data Form

Each form contains fields for the collection of the data given in the list below. The Project Team and the liaison for the sponsoring agency, David J. Friend, Assistant Director for Transportation at the Brookline Department of Public Works, developed the list of characteristics to be included in parallel. Thus, it is thought that obtaining data for each of these variables should produce a complete and accurate inventory. The information was compiled and then entered into an Access database in an organized and concise fashion (Section 3.4).

- Intersection Data
 - North/South Street.
 - East/West Street.
 - Date of inventory.
 - Inventory Staff.
 - Location ID.
 - Aerial Photograph.
- Physical Crosswalk Data
 - Crosswalk Type.
 - ADA Compliance.
 - Presence of a median or center island.
 - Pavement marking material.
 - Condition of marking material.
 - Marking dimensions and spacing of lines (on center).
 - Distance between the crosswalk and stop bar.
 - Width of sidewalks on both sides of the crosswalk.
- Street on Approach
 - Number of travel lanes at the crossing (including turning and bike lanes).
 - Presence of pedestrian and traffic signals.

- Presence of a stop sign, yield sign, or other control.
- Presence of parking on either side of the crosswalk.
- Presence of a street lamp within 20 feet of the crosswalk.
- Posted speed limit.
- Presence of a bus stop.
- Direction of one-way streets.
- Signage and Treatments
 - Curb extensions.
 - Center islands.
 - Raised crosswalk.
 - Flashing yellow lights.
 - School zone flashers.
 - Portable “Yield to Pedestrian” signs.
 - Crosswalk Sign (W11A-2).
 - Arrow Sign (W16-7p).
 - Advance pedestrian warning signage (W11-2).
 - Yield to Pedestrian Signage.

The majority of the data collected concerns static variables. The focus of this study was crosswalk maintenance, and much of the dynamic data that could have been collected pertains more to crosswalk safety than to maintenance practices. One pertinent dynamic variable would be the average daily traffic (ADT) for both pedestrians and vehicles, and also possibly turning movements. This data would be useful in building a regression model aimed at the prediction of crosswalk condition at a given point in time, and the prediction of marking material lifetime. The temporal boundaries of this project did not realistically allow for the collection of such dynamic data at each of the 393 locations inventoried, however, and if the data was not already available from another source, it was not included with this study.

Having completed the GIS inventory, and thus located the vast majority of the marked crosswalks within Brookline, it was then possible to prepare customized data forms for each location and conduct a field inventory. Aerial photographs of each location were prepared from the Brookline GIS system and inserted into the field form. The location ID was typed in and a copy of this digital version was printed for use in the field. Sketches were drawn (while on site) for locations with crosswalks for which aerial photographs did not show a visible crosswalk. An example form for the crosswalks at the

intersection of Aspinwall Avenue and Kent Street can be found in Appendix B (the first page can be seen in Figure 5 as well).

As seen in the Appendix and figure, the original data forms used include space for approach photos as well as the aerial. Because these photos did not yet exist, they could not be entered into the form. These sections were designed more as a report than as a field form, and thus were ignored in the field.

Brookline Crosswalk Inventory		Location ID: _____	
		page 1 of 4	
Location	Location ID: ASPINWALL AVE KENT ST	East/West Street: ASPINWALL AVE	Survey staff: MATT CICHON
	Date performed: 4 / 5 / 05	North/South Street: KENT ST	MICHAEL RYAN
	Aerial Photo: 	Notes:	
Photo of Crosswalk	Approach 1	Approach 2	Approach 3

Figure 15: Page 1 of the Aspinwall Ave Kent St Field Data Form

3.3 Field Inventory of Marked Crosswalks

Field inventory was conducted in two groups of two persons. Prior to this split, the study team conducted several comparative test cases to ensure a consistent level of objectivity amongst the Project Team. Measuring wheels were used to determine the length, width, and line spacing of the crosswalks, as well as the width of sidewalks and the distance to a stop line. One team was equipped with a measuring wheel accurate to a tenth of a foot, while one team used a smaller wheel accurate only to the nearest foot. The more accurate measurements were included in the database, however, all results will be reported in the least accurate measurement and to the nearest foot. A tape measure was used to measure the width of each bar, and also to double check the spacing distance.

An original goal of this study was to determine the ADA compliance of each location. The temporal aspects of the project, however, did not allow for such a time

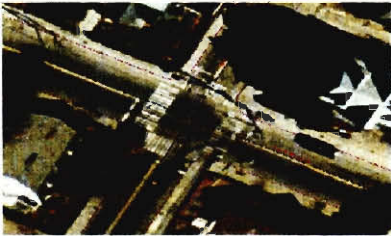
consuming study. The presence of pedestrian ramps at each location was instead included in the inventory, and it was decided that the compliance of each location should be judged in the future. A field for compliance with ADA regulations was included in the design of the database (Section 3.4) to allow for easy integration of this data as it becomes available.

During the course of the inventory it also became apparent that there are several marking materials, which are difficult to differentiate once they have been applied to pavement. The Project Team determined the material used at each location to the best of their ability, and requested from the Highway Department and records, which may include the materials used at certain locations. A brief list of locations and the materials used was returned to the Study Team, and the inventory updated accordingly. This list was produced largely from memory, and little if any documentation actually exists. It was then decided by the Team that this is an issue that falls within the scope of this study, and a solution should be proposed.

Digital pictures of crosswalks on each approach were taken at each location. An easy method of correlating the digital pictures to the crosswalks themselves was devised. The digital camera used names each photo as a series of sequential numbers in the order in which they were taken, and with respect to the date on which they were taken. This allowed a zoomed picture of the street sign at the location to be taken, and then a picture of each approach at that location. The pictures were taken sequentially, starting from approach one and proceeding to approach two. Thus, when the pictures were uploaded to a computer, they were numbered in order and those pictures following a picture of a street sign were the pictures of the crosswalks at the location indicated by that street sign, in order of approach. The pictures were then renamed and given a unique and descriptive ID. The ID used was the same ID given to the crosswalk at which they were taken. Locations with a street sign indicating the name of only one street were further identified as necessary. For instance, if the location at one such intersection had four crosswalks, and another such intersection along the same street had only two, there is no need to further differentiate between them, as the location can be determined by the number of pictures.

3.4 Condition Ranking

Evaluation of the crosswalk condition was based on a visual ranking system, and done on site at the time of inventory. The evaluation was also limited to the marking material used, and other characteristics of the crosswalk location that may influence the overall condition of the crosswalk were not included in this study. The temporal scope of the project did not realistically allow for the evaluation of characteristics such as illumination, which must be done at night, sight distances, and stopping distances. These factors were not thought to be as important as the marking material, however, as sight and stopping distances should have been determined accurately and correctly during the design and installation of the intersection and crosswalk, and illumination is only an issue during the nighttime hours when pedestrian traffic is minimal. The primary purpose of a marked crosswalk is to direct pedestrians to a crossing area of high visibility, thus the condition and visibility of the crosswalk marking material is likely the most important influence on overall condition.

The condition evaluation will be conducted qualitatively and comparatively. All of the crosswalks will be compared to four sample crosswalks featured on the field data form exhibiting the features in four categories below. Figures 6 – 9 show the examples for each category used on the field data forms.

- Crosswalks with solid lines and bright

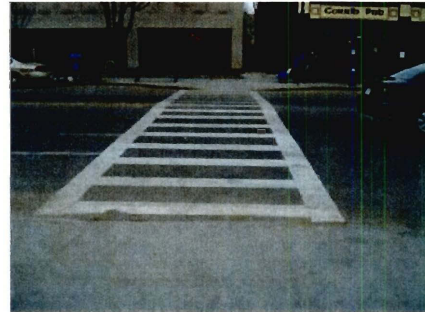

Figure 16: Excellent Condition

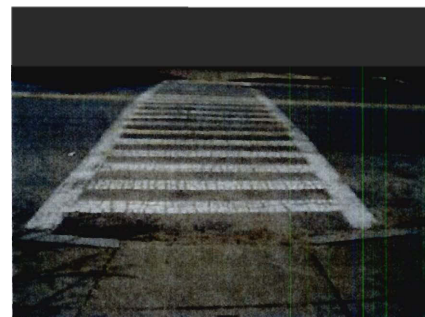

Figure 17: Good Condition

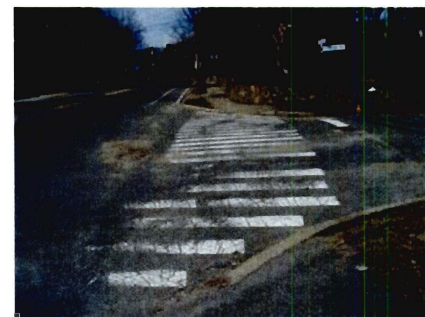

Figure 18: Fair Condition

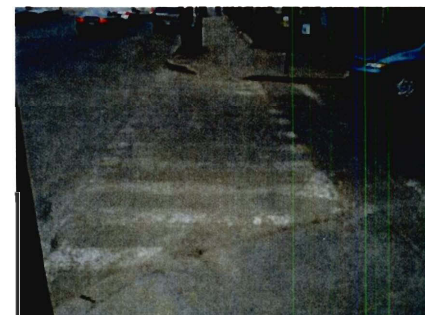

Figure 19: Poor Condition

markings will receive a rating of “Excellent.”

- Crosswalks with solid lines and with markings slightly faded, or with broken lines and bright markings will receive a rating of “Good.”
- Crosswalks with broken lines and faded markings will receive a “Poor” rating.
- Crosswalks with broken lines and markings completely or almost completely gone will receive a rating of “Poor.”

3.5 Database Development

The easiest and most useful way of storing and accessing all of the information gained from the inventory is the use of a database. Databases can store a large amount of information in an organized format, provide user friendly forms for the input of new data entries, and also can generate customized reports for analysis. The software used for this study (Microsoft Access) has the added advantage of GIS compatibility. This feature allows the information stored in the database to be linked to objects in a GIS map layer, and viewed in the attribute table.

All of the data gathered in the inventory will be entered into corresponding database fields. To facilitate data management, the data was divided amongst several tables including Intersection Data, Physical Data, Signage and Treatments, and Street on Approach. Two forms were developed for data entry, one containing the intersection data (Figure 10) and another for each approach (Figure 11).

As a user inputs data into the forms, the data is added to the various tables containing each field. Drop boxes were determined to be the user-friendliest means for entering crosswalk condition, type, and marking material. Only specific values should be entered into these fields to ensure the uniqueness of each value. The available options for each of the drop down menus are stored in tables within the database, and values may be removed or added as needed. The names of inventory staff may also be added to a corresponding table within the database and will thus show up for selection on the form.

Location		Date of Inventory	Intersection ID
CHESTNUT HILL AVE HYSLOP RD		4/5/2005	
North/South Street	East/West Street	# of Approaches	# of Crosswalks
CHESTNUT HILL AVE	HYSLOP RD	3	1
Aerial Photo ID		<input type="checkbox"/> Traffic Signal	
CHESTNUT HILL AVE HYSLOP RD			
Inventory Staff	Notes		
Michael Ryan & Elliott Eno			
Michael Ryan & Matthew Cichon			
Michael Ryan & Kevin Mullins			
Elliott Eno & Matthew Cichon			
Elliott Eno & Kevin Mullins			
Matthew Cichon & Kevin Mullins			

Figure 20: Intersection Database Form

Location LONGWOOD AVE ST PAUL ST		Approach # 1	
Crosswalk ID: LONGWOOD AVE ST PAUL ST 1		Posted Speed Limit 30MPH	
Photo ID LONGWOOD AVE ST PAUL ST 1		# of Travel Lanes 3	
Crosswalk Length (ft) 33.8	Marking Condition Poor	Width of Bars (ft) 1	Width of Perpendicular Lines (ft) 1
Crosswalk Width (ft) 10	Marking Materials Thermoplastic	Color of Bars WHITE	Color of Perpendicular Lines WHITE
Spacing of Bars (ft) 2	Crosswalk Pattern Ladder	<input type="checkbox"/> Bus Stop	Distance to Stop Bar (ft) 10.5
Crosswalk Treatments: <input checked="" type="checkbox"/> Pedestrian Signal <input checked="" type="checkbox"/> Ramps <input type="checkbox"/> Curb Extensions <input type="checkbox"/> ADA Compliant <input type="checkbox"/> Center Island <input type="checkbox"/> Flashing Yellow Lights <input type="checkbox"/> Raised Crosswalk <input type="checkbox"/> Advanced Pedestrian Warning Sign <input type="checkbox"/> Portable YTP Sign Other Treatments:		Control and Signage: <input type="checkbox"/> Stop Sign <input type="checkbox"/> Crosswalk Sign (W11A-2) <input type="checkbox"/> Yield Sign <input type="checkbox"/> Arrow Sign (W16-7p) <input type="checkbox"/> No Control <input type="checkbox"/> Yield to Pedestrian Other Control:	
Notes:		<input type="checkbox"/> Parking on Left Side <input type="checkbox"/> Parking on Right Side <input checked="" type="checkbox"/> Sidewalk on Left Side <input checked="" type="checkbox"/> Sidewalk on Right Side Width of Sidewalk (ft): 8 7	

Figure 21: Approach Database Form

The unique crosswalk identification value assigned to each crosswalk inventoried was selected as the primary key for database tables. This enables one form to be used to enter data into multiple tables, and ensures that values entered for a given crosswalk in one table, correspond to other values for that crosswalk in a different table.

The database was designed with future use in mind. A field for ADA compliance was included, allowing for such data to be added as it become available without any major re-design of any of the tables or forms. In addition to this, a table and form were designed to facilitate the collection of crosswalk condition time data. Users will be able to survey the condition of crosswalk locations and enter in the condition on a given date. All of this information will be stored in a table, along with the last time the location was maintained. Thus the creation of an entire service and condition history of a particular crosswalk will be possible.

A “Condition History” table and form were added to the database in order to assist with future time data collection and regression studies. This table will contain the crosswalk ID, the date and condition of the original inventory, as well as fields for the date and condition for five subsequent inventories. The table also contains fields for the date of, and measures taken during the last maintenance period for the location. This should allow for future studies to use both short and long time intervals.

4 Results and Analysis

The GIS inventory located 585 crosswalks throughout the town (Figure 22). The field inventory was concentrated in the northern area of the town, where crosswalk density is highest. Examples of the five crosswalk types found in Brookline are shown in Figure 23. Brick was chosen to describe the solid marking pattern because all of the solid pattern crosswalks inventoried used an inlayed brick material to produce the solid pattern.



Figure 22: Locations of all crosswalks found during the GIS inventory.

The most common crosswalk in the town was found to be a ladder style crosswalk, painted onto the roadway with chlorinated paint, in poor condition (Table 1). The data show that the crosswalk type used most frequently by the town is the ladder and that chlorinated paint is the most widely used marking material. The prevalence of poor condition likely reflects the need for better maintenance practices and the lack of a previous inventory. Maps showing the locations, conditions, and types of pattern used throughout the northern part of the town can be found in Appendices F and G.

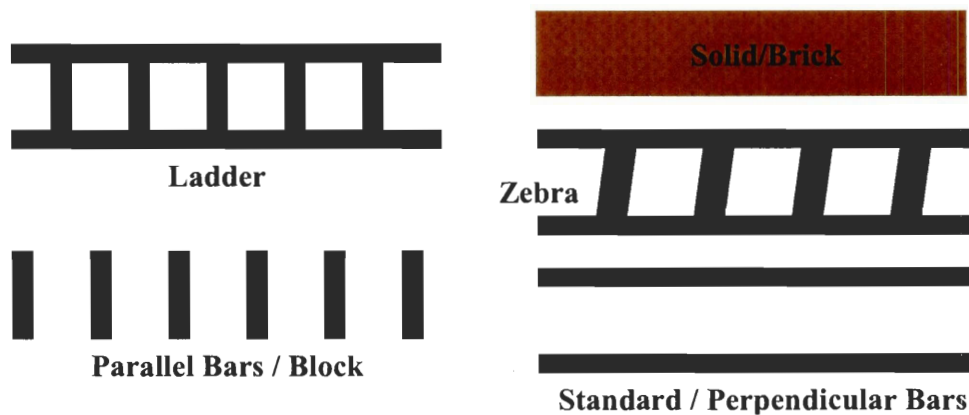

Figure 23: The marking patterns found in Brookline.

Table 1: Number of crosswalks inventoried that fall into the given subclasses of condition, material, and type.

Condition	# of Crosswalks	Marking Material	# of Crosswalks	Crosswalk Type	# of Crosswalks
Excellent	41	Chlorinated Paint	251	Standard	21
		Thermoplastic	105		
Good	51	Inlay Tape	7	Block	44
		Tape (Not Inlay)	6		
		Brick	4		
Fair	74	3M Polymer	2	Zebra	34
		Epoxy Paint	6		
Poor	227	Inlay Tape / Chlorinated Paint	1	Ladder	285
		Thermoplastic / Chlorinated Paints	11		

In seeking to develop the most cost effective maintenance policy for the town, one of the major issues was the selection of a standard crosswalk type to be used at a given location. To resolve this issue the team attempted to determine if a correlation between crosswalk type and condition existed. The amount of crosswalk marking in linear feet of each type in each of the four conditions was calculated. These amounts and the total linear feet of each crosswalk type can be found in Table 2. The vast majority (77.6%) of the total 103,513 linear feet of crosswalk markings within the town are in “fair” (20.3%) or “poor” (57.3%) condition. Only about 8% of the crosswalks included in the inventory received a condition rating of “excellent” and only approximately 14% warranted a “good” rating.

Table 2: Condition, Type and Quantity of Crosswalks in linear feet of marking.

Pattern Type vs Condition (L.F.)	Excellent	Good	Fair	Poor	Type Totals
Ladder	6,054.25	11,293.91	15,048.65	44,879.75	77,276.56
Parallel Bars (Block)	0	414.8	2,346.33	6,628.40	9,389.53
Zebra (Diagonal)	889.50	1,120.37	3,218.15	7,121.28	12,349.30
Perpendicular (Standard)	836.2	314.2	0.00	710.60	1,861.00
Brick Inlay	658.52	1640	338.00	0.00	2,636.52
Condition Totals	8,438.47	14,783.28	20,951.13	59,340.03	103,512.91

To better examine this data, the percentages of crosswalk marking pattern in each condition was calculated for each crosswalk type (Table 3). The data show that inlaid brick crosswalks as well as standard perpendicular markings throughout the town were generally rated as having “good” or “excellent” condition, while other marking patterns were generally in “fair” or “poor” condition. This may be the result of higher traffic volumes at locations where ladder, block, and zebra patterns are used and not necessarily an indication of the effectiveness of the pattern itself.

Table 3: The percentage of each crosswalk type in each of the four conditions.

Pattern Type vs. Condition	% Excellent	% Good	% Fair	% Poor
Ladder	7.83	14.61	19.47	58.08
Parallel Bars (Block)	0.00	4.42	24.99	70.59
Zebra (Diagonal)	7.20	9.07	26.06	57.67
Perpendicular (Standard)	44.93	16.88	0.00	38.18
Brick Inlay	24.98	62.20	12.82	0.00

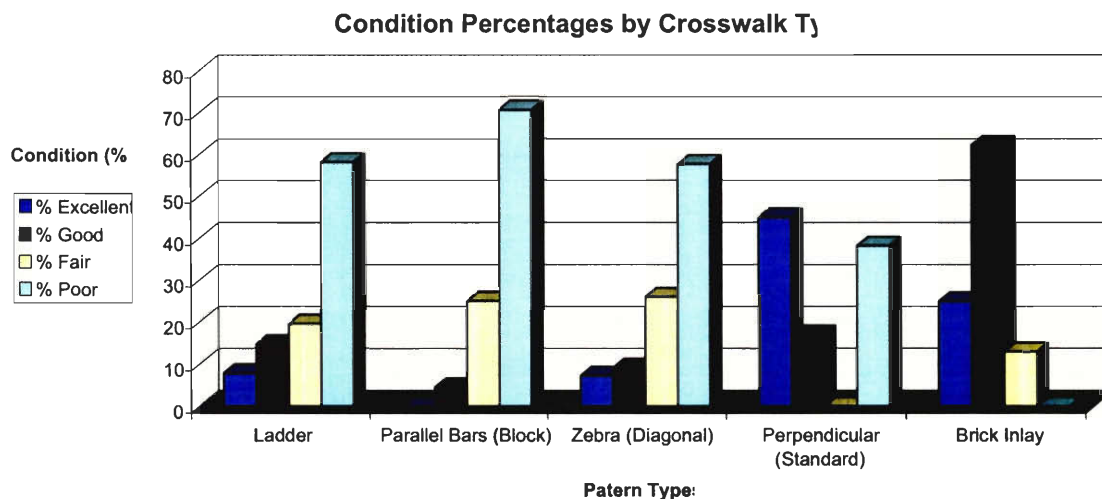

Figure 24: Percentage of each marking pattern in each condition.

Figure 24 shows the extent to which poor condition prevails across almost all pattern types. It should be noted that the ladder, block, and zebra marking patterns share a similar trend, and that the brick and standard patterns deviate from this trend. The

data suggest that similar performance can be expected from ladder, block, and zebra patterns in similar conditions. No definite conclusions can be made with respect to the standard and brick patterns; however, as it cannot be determined whether the trends shown are a result of the marking patterns or a result of the relatively small sample size of crosswalks in these categories.

The inventory also made it possible to quantify the amount of each marking (Table 4). Chlorinated paint is the material most widely used to mark crosswalk locations with almost 67,000 linear feet (64.6%) of markings being made with the paint. Thermoplastics have been used to mark over 25,000 linear feet (24.8%) and tapes have been used to mark almost 4,000 linear feet (3.8%). This material is fairly new, and must be installed immediately after the paving of a roadway while the mix is still hot. Only a handful of locations have been resurfaced since this material became available, and this may account for the low use of the tape material. The Highway Department is currently experimenting with other materials, and these account for the majority of the remaining crosswalks. Inlaid brick markings accounted for less than 1,000 linear feet (<1%) of the total linear feet of crosswalk.

Table 4: Total amount of each marking material used for each crosswalk type. Values given are in linear feet.

Pattern Type vs Material (L.F.)	Ladder	Block	Zebra	Standard	Brick Inlay	Totals
Chlorinated Paint	55,834.02	3,924.29	4,991.80	661.8	1,440.00	66,851.91
Inlay Tape	3,796.09	0.00	0.00	97.4	0.00	3,893.49
Thermoplastic	13,525.41	5,465.23	5,964.00	661.80	0.00	25,616.44
Thermoplastic / Chlorinated Paints	2,060.00	0.00	703.00	0.00	0.00	2,763.00
Tape (Not Inlay)	165.93	0.00	0.00	386.00	0.00	551.93
Brick	0.00	0.00	0.00	54.00	858.52	912.52
3M Polymer	0.00	0.00	690.50	0.00	0.00	690.50
Inlay Tape / Chlorinated Paints	0.00	0.00	0.00	0.00	338.00	338.00
Epoxy Paint	1,895.10	0.00	0.00	0.00	0.00	1,895.10
Totals	77,276.55	9,389.52	12,349.30	1,861.00	2,636.52	103,512.89

The uses of the three major marking materials were also studied in an attempt to correlate the uses of specific materials to specific marking patterns. The amount of a

material used to mark a given pattern was divided by the total amount of all materials used to mark that same pattern. This resulted in the percentage of each material used to mark each pattern (Figure 25). Paint is the material usually employed to mark ladder patterns as well as to mark the perpendicular bars of brick crosswalks. Thermoplastic and paint are used in almost equal frequency to mark block, zebra, and the standard marking patterns. Inlay tape has only been used in ladder and standard patterns by the town. This is likely the result of the installation requirements previously discussed, and an effort by town officials to standardized the marking patterns used.

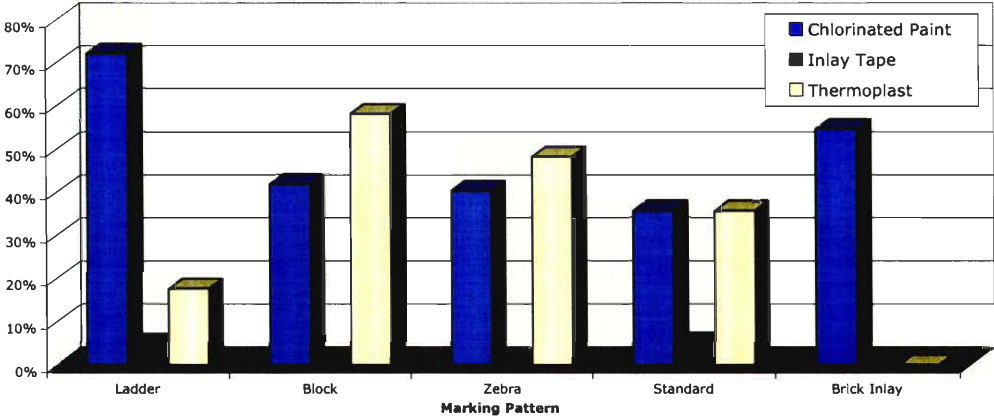

Figure 25: Crosswalk types and common marking materials.

Current price estimates were requested for the three major marking materials including two different types of the marking tape. Price quotes were also requested from the current and previous vendor under contract for marking crosswalks in Brookline. The previous contractor, Hi Way Safety Systems, calculates cost based on the total amount of material included in the contract. As the total number of linear feet of material needed was not available at the time of the request, the quotes given are a general estimate and likely less accurate than those received from the current contractor, Markings Inc. The manufacturer of the marking tapes (3M) was also contacted and a quote obtained for the cost of the material alone. Quotes received from the contractors include the materials to be used only, and do not cover the costs of labor during installation. The various costs of the materials can be found in Table 5.

Table 5: Price quotes (\$/L.F.) for cost of materials received from two contracting firms, and also from a manufacturer of tapes (3M).

Material	Vendor and Price		
	Markings Inc.	Hi Way Safety Systems	3M
3M 380I ES Tape	\$5.45/ft	\$6.00/ft	\$4.44/ft
3M 420 Tape	\$5.65/ft	\$6.00/ft	\$3.94/ft
Thermoplastic	\$1.30/ft	\$1.25/ft	N/A
Paint	\$0.35/ft	\$0.50/ft	N/A

This cost data was used to calculate cost estimates to upgrade Brookline crosswalks. The average Brookline crosswalk was calculated to be 9.44 feet wide and 44.10 feet in length. All marking patterns were included in the calculation of these average dimensions. The average on center spacing of ladder, zebra, and block patterns was found to be 2.17 feet. Zebra markings were assumed to be equivalent to ladder markings for the purposes of these estimates. The inner bars of the zebra pattern are slightly longer than those of a ladder because they are marked at an angle, however this angle was not included in the inventory and thus the length of the interior bars could not be determined. The cost of installing each marking pattern was then calculated based on the quotes obtained from Markings Inc., and the calculated average dimensions (Table 6). The data show that in the case of a crosswalk of average dimensions, standard markings require about one third of the material needed to mark a ladder pattern, and are thus one third as costly.

Table 6: Cost of installation by contractor for each pattern type and material. Values based on the average dimensions of Brookline crosswalks.

Pattern Type and Material	Cost Of Material and Installation (By Contractor)		
	Inlay Tape	Thermoplastic	Paint
Ladder	\$1,533.25	\$352.78	\$94.98
Parallel Bars (Block)	\$1,034.87	\$238.11	\$64.11
Perpendicular (Standard)	\$498.38	\$114.67	\$30.87
Zebra (Diagonal)	\$1,533.25	\$352.78	\$94.98
Brick Inlay	N/A	N/A	N/A
Average Dimensions of Brookline Crosswalks:	Width (ft)	Length (ft)	
	9.44	44.10	

The cost of using each material to mark the total amount of every crosswalk location was calculated, and these values can be found in Table 7. These values are again based on the material quotes received from Markings Inc., and the total linear feet of marking material inventoried. It is possible to upgrade all crosswalks in less than excellent condition with just a little over \$33,000 using paint. Highway Department staff put the effective lifetime of this material at six months based on their personal experience, however, as the paint is put down during the summers and is worn away during the New England winters. A complete upgrade using thermoplastic material would require approximately \$123,600. Highway Department staff testified to a one to two year effective lifetime for this material. Inlaid tape has been at some locations in the town for as long as five years and has maintained its effectiveness and good condition. A complete upgrade with this material would cost the town approximately \$537,000. It should be noted that these figures represent the costs of materials only, and that the tape would need to be installed during roadway resurfacing or reconstruction.

Table 7: Cost estimates for the upgrade of all crosswalks in a given condition to excellent condition by material.

	Rating Condition and Cost of Upgrade to Each Material			
	Good	Fair	Poor	Totals
Cost to Upgrade with Paint	\$5,174	\$7,333	\$20,769	\$33,276
Cost to Upgrade with Tape	\$83,526	\$118,374	\$335,271	\$537,171
Cost to Upgrade with Thermoplastic	\$19,218	\$27,236	\$77,142	\$123,596

Based on the current budget of \$40,000 allotted to the Highway Department for crosswalk maintenance, the number of years required to update all the crosswalk markings with each material could be determined (Table 8). This budget includes all of the funds available for all pavement markings of any kind throughout the town, and includes Beacon St. It has been the experience of the Highway Department that this budget is sufficient only to allow for the yearly repainting of Beacon Street, which is repainted each year prior to the Boston Marathon. Thus the actual yearly budget for crosswalk maintenance is much less than \$40,000. If the budget was to be doubled, however, and a complete \$40,000 devoted to crosswalk maintenance, all of the

crosswalks inventoried could be repainted each year. It would take three years and over thirteen years to fund thermoplastic and tape updates respectively.

Table 8: Time in years required for maintenance of inventoried crosswalks under the current budget by condition and material used.

	Time Required for Maintenance Under Current Budget			
	Good	Fair	Poor	Totals
Time to Upgrade with Paint (Yrs)	0.13	0.18	0.52	0.83
Time to Upgrade with Tape (Yrs)	2.09	2.96	8.38	13.43
Time to Upgrade with Thermoplastic (Yrs)	0.48	0.68	1.93	3.09

Though the cost of inlayed tape material is over 16 times the cost of chlorinated paint, it is still likely to be the more cost effective material. Detailed data on the number of man-hours needed to install these materials at each crosswalk must be gathered to determine this fact conclusively, but the labor costs of the yearly use of paint likely make the product more expensive in the long run. This is especially true when considering that the effective life of paint is about six months, and that the crosswalks should be painted twice a year. It may also be necessary to include traffic data in such an analysis, as this is likely the deciding factor in determining the effective lifetime of the tape. Traffic volume probably has little influence on the effective lifetime of paint, as the determining factor is most likely to be the winter weather and snow removal activities.

Table 9: Dollars required per year to purchase the amount of tape material needed to upgrade all crosswalks in the given condition directly from the manufacturer 3M.

	Possible Financial Plan for the Purchase of 3M Tape			
	Good	Fair	Poor	Totals
5 Year Budget (\$/Yr)	\$16,705	\$23,675	\$67,054	\$107,434
10 Year Budget (\$/Yr)	\$8,353	\$11,837	\$33,527	\$53,717

The need to install inlayed tape with the resurfacing or reconstruction of a roadway also helps to make the material more affordable. This may allow the town to “piggy-back” the funds needed to install the tape material along the sections of roadway to be resurfaced each year by including the crosswalk installations with the budget proposal for the project as a whole. Thus the funds for the installations of these crosswalks would not come from the normal maintenance budget. The small number of

roadways resurfaced in Brookline each year also allows the \$537,000 needed to be spread out over several years while paint was used to maintain the other existing crosswalks. The budget needed to install inlay tape as part of a five and ten-year financial plan was also determined (Table 9)

There were 11 locations with three crosswalks on each of the three approaches to a T intersection. In nine of these cases, one of the crosswalks at each location could be removed (See Section 5.3). Based on the dimensions of the crosswalks to be removed, the materials used at the location, and the price estimates obtained from the contractor currently employed by the town, it is estimated that the removal of these extraneous crosswalks would result in a \$724 savings each maintenance period. The savings breakdown for each location is shown in Table 10. The three locations circled in Figure 26 (Appendix C) are highlighted in the table as well. The redundant crosswalks in the figure are colored red.

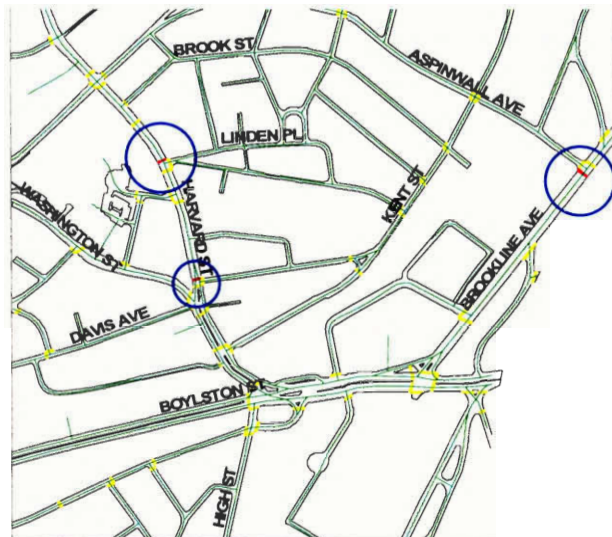

Figure 26: The locations of three T intersections with redundant crosswalks.

Table 10: The estimated savings of removing a redundant crosswalk at a T intersection.

Crosswalk ID	Savings (\$)
WASHINGTON ST HARVARD ST KENT ST 1	\$49.00
WEST ROXBURY PKWY PUDDINGSTONE RD 2	\$27.72
BROOKLINE AVE ASPINWALL AVE 2	\$54.95
ELIOT ST ACKERS AVE 3	\$38.29
WALNUT ST OAKLAND RD 1	\$111.80
HARVARD ST LINDEN PL 1	\$53.13
HARVARD ST SEWALL AVE STEARNS RD 3	\$166.30
CYPRESS ST HIGH ST 1	\$172.93
HARVARD ST BABCOCK ST 3	\$49.95
Total Savings:	\$724.07

The two primary functions of a crosswalk are to direct pedestrians to cross at the specified location and to make this location visible to motorists. At approaches with a

traffic signal there is not a need for high visibility because traffic on the approach will be completely stopped for at least one signal phase. In such cases a standard pattern is all that is required to direct pedestrians to the crossing location. Using a standard pattern at signalized approaches would substantially reduce the amount of material needed to mark the crosswalk.

Of the locations inventoried, 32 were found to be signalized and have crosswalks. Of the estimated 128 approaches at these intersections, 96 were zebra, block, or ladder patterns. A portion of these locations can be seen in Figure 27 (Appendix D). The crosswalks colored red in the figure use ladder, block, or zebra marking patterns and are on signalized approaches. Those in yellow are on non-signalized approaches. The locations along Beacon Street are colored yellow because these were not included in the inventory.

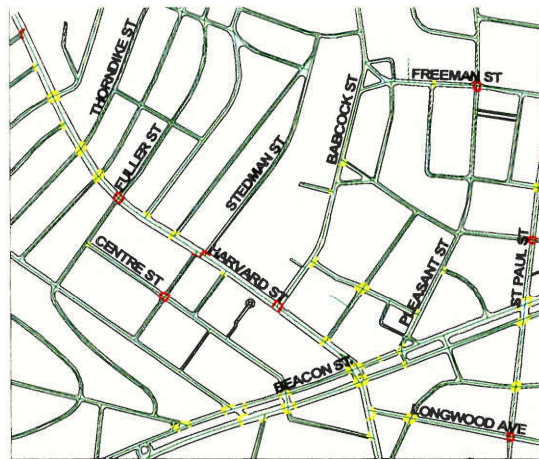

Figure 27: Map showing crosswalks with a non-standard pattern at signalized approaches in the area of Harvard St at Beacon St.

Conversion of these crosswalks to the standard pattern would cut both materials and cost by 1/3 in the case of the zebra and ladder patterns, and by 1/2 for block patterns. The total linear feet of material needed to paint the existing patterns, and the material needed to paint standard patterns at these locations is given in Table 11. The last column of the table show the amount of “extra” material (in linear feet) that is required through continued use of patterns other than the standard perpendicular bars, and Table 12 estimates the cost of the continued use of this extra material for each of the three major marking materials using the quotes received from the current contractor.

Table 11: The amount of material (L.F.) in use at signalized intersections broken down by pattern and the material required for a standard pattern at the same locations.

Pattern Type	Linear Feet of Patter	Linear Feet of Standard	Linear Feet Difference
Zebra	2,254	719	1,535
Block	598	384	214
Ladder	19,477	5,892	13,585
Totals	22,329	6,995	15,334

Table 12: Dollars required to maintain the “extra” L.F. of ladder, block, and zebra patterns at signalized intersections by material.

Material	Dollars
Paint	\$5,367
Thermoplastic	\$19,935
Tape	\$86,639

One of the goals of this study was to determine the possible cost benefits of the town returning to the practice of exclusively utilizing Highway Department work crews for the installation of crosswalk markings, and removing contractors from the process. The town has the equipment needed to do the installations and maintenance itself for many of the possible materials. A price comparison between contracted and “in-house” work is somewhat difficult, as it is unknown how long it would take work crews to install a given crosswalk. The installation time varies greatly depending on the specifics of each location.

The cost estimates obtained from both Markings Inc. and the material manufacturer 3M for the 420 series tape marking were compared and the difference determined and taken as savings. This difference was then divided by the estimated hourly wage of a town employee working to install a crosswalk overnight of \$35/hr to determine the number of man-hours the savings could fund. While the cost of labor is still unknown, it can be assumed that in-house and contracted work crews would require approximately the same number of man-hours to install any given crosswalk. Thus, it is possible to determine if in-house work or contracting is more cost effective for the installation of the 3M tape material based on the price of materials alone.

The average dimensions of the town’s crosswalks were used to generate the data given in Table 13 below. The prices shown are based on price quotes received for the purchase of 3M brand 420 series intersection grade marking tape from Markings Inc. (\$5.65/L.F.), and for direct purchase from the manufacturer (\$3.94/Sq.F.).

Table 13: A comparison of the cost of 3M tape material purchased from the manufacturer and contractor, and the number of hours or Highway Department staff can be paid for with the difference.

Pattern Type	Cost of Inlay Tape Installation			
	Contractor	Manufacturer	Difference	# of Man Hrs at \$35/Hr
Ladder	\$1,533.25	\$1,069.21	\$464.05	13.26
Parallel Bars (Block)	\$1,034.87	\$721.66	\$313.21	8.95
Perpendicular (Standard)	\$498.38	\$347.54	\$150.84	4.31
Zebra (Diagonal)	\$1,533.25	\$1,069.21	\$464.05	13.26

Direct purchase of this material would save the town a considerable amount of money and a considerable number of man-hours could be paid for with this savings. Using the example of the average ladder crosswalk, the town could afford to pay a work crew 13 man-hours at \$35/hr (the average wage earned for a night shift during which crosswalks would be installed) with the savings of \$464 that would result from direct purchase of the material. Three workmen would likely be required to install this material. Dividing the available 13 man-hours amongst them, it could take this work crew of 3 men 4 hours to install a crosswalk with this material, and the town would still have a net savings. It is more likely that a work crew could install several crosswalks in the four hours, resulting in a large net savings for the town.

It should be noted that there are numerous other advantages to eliminating the contracting of crosswalk markings. The existing practices require the presence of a town employee to supervise and observe the installation of markings by contractor personnel, however, the training of existing staff to install crosswalk materials and patterns would simplify this quality control. It is possible the supervising position could be eliminated, or that the supervising staff member also be involved with the actual installation. It is also likely that the use of in-house personnel would result in a higher quality of labor and increased quality of the end product as the staff gained experience with the process.

The condition of crosswalks in close proximity to schools is of special consideration. These crosswalks need to be well maintained as they are in areas of high traffic volume and serve younger pedestrians and must be visible to direct children to a safe crossing location. Figure 28 (Appendix E) shows an area of Brookline between Beacon St and Boylston St near the eastern edge of the town. Blue stars show the locations of area schools and the shaded regions surrounding them represent a quarter mile school zones. The position of surrounding crosswalks is also given along with the crosswalk condition. Red denotes a crosswalk in poor condition. Further analysis of the entire town revealed that the majority of crosswalks within school zones are in poor condition, consistent with the profile of the entire town.

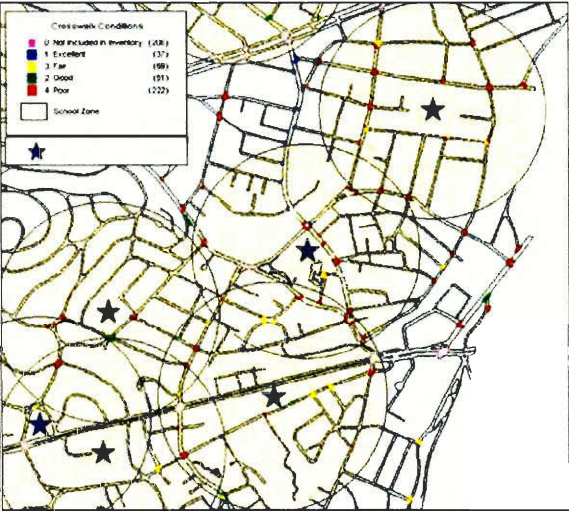

Figure 28: Crosswalk location and condition within quarter mile school zones.

The majority of Brookline crosswalks were found to be in poor condition. Many of these are within a quarter mile of a school and should receive maintenance as soon as possible. The prevalence of the poor condition suggests that the current budget is not adequate for proper crosswalk maintenance and that this budget should be significantly increased to allow for the painting of existing crosswalks. The preferable long-term solution would be to identify a long lasting material, possibly an inlayed marking tape, and to install it at crosswalk locations as roadways are resurfaced. Several locations in the town require excess material and eliminating the use of this material through the removal of extra crossings at T intersections and the use of standard marking patterns at signalized intersections would save appreciable amounts of money each maintenance cycle. The data show that a doubling of the current budget would be the first major step towards improving marking quality and condition. There should be no question that an accurate and complete inventory can be a powerful tool in identifying existing problems and planning possible solutions.

5 Policy Discussion

The following section presents a proposed policy for the installation and maintenance of crosswalks in the town of Brookline. These recommendations contain information pertaining to pavement marking materials needed, types of lines required, widths of perpendicular and parallel lines, the types of markings necessary and signage required at certain intersections. Several different types of intersections are also distinguished in these specifications, including intersections with four or more approaches, T-intersections (3 approaches), skewed intersections, and rotaries. All of the intersection types can be signalized or non-signalized and can be located on either residential/local roads or arterial/collector roadways. Mid-block crosswalks are also important and are discussed in this section. As stated previously, the proper treatment for each possible crosswalk will be stated and discussed in the following list of recommendations. The recommendations represent a review of current literature, insights gained during the field inventory, and some existing practices.

5.1 Crosswalk Type and Specifications

- **Controlled Approaches**

At approaches where a traffic signal or stop sign is present the approach is considered “controlled”. Crosswalks at these approaches shall be of the standard perpendicular line type and shall not contain crossbars. A standard perpendicular line type is recommended since it is believed that where traffic is controlled, the placement of a crosswalk acts as more of a guidance to the pedestrian of where to cross than as a visible warning to vehicle operators. A ladder pattern may be necessary, however, on approaches with higher traffic and pedestrian volumes. An appropriately placed stop bar to protect crossing pedestrians through the creation of a buffer zone should accompany these crosswalks (Figure 29).

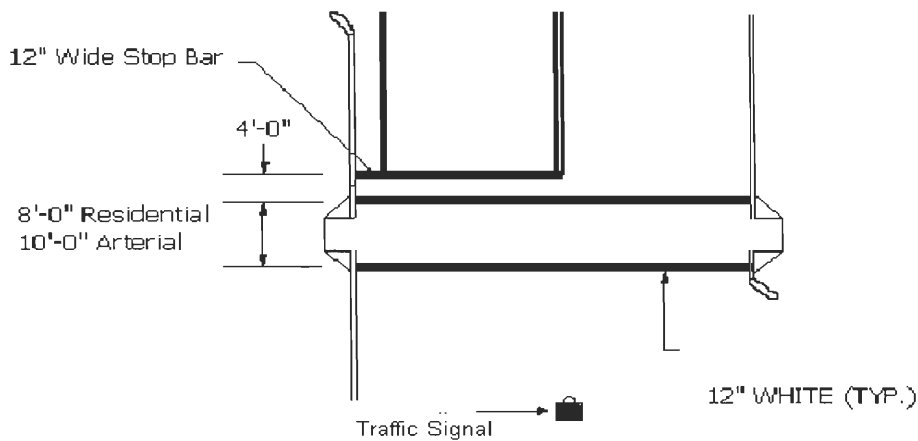

Figure 29: Controlled Approach Striping Detail.¹⁷

On residential/local roadways, the width of the crosswalks at controlled intersections should be 8'0" on center. On arterial/collector roadways the width of crosswalks should be 10'0" on center. There is to be a minimum of 4'0", on center, between crosswalk and stop bar. All longitudinal lines, regardless of their marking material, should be solid white with a width of 12". For recommendations on what type of marking material should be used, refer to the section titled "Marking Materials".

- **Uncontrolled and Mid-Block Approaches**

At approaches where a traffic signal or stop sign is not present the intersection is considered "uncontrolled". These approaches may either be at an intersection or a mid-block location. Mid-block crosswalks are not located immediately at an intersection, and they allow pedestrians to cross the street more conveniently. Crosswalks at these approaches shall be of the ladder type, which means that they should consist of two longitudinal lines connected by crossbars as shown in Figure 25. A ladder type is recommended since it is believed that where traffic is not controlled at these locations, it is necessary to use a crosswalk which will both act as

¹⁷ Design schismatic courtesy of Charles Barry, Senior Civil Engineer, Brookline Transportation Division. These specs were recently developed and have been used as unofficial standards on recent projects.

a visible warning to vehicular operators and guidance to pedestrians of where to cross (Figure 30).

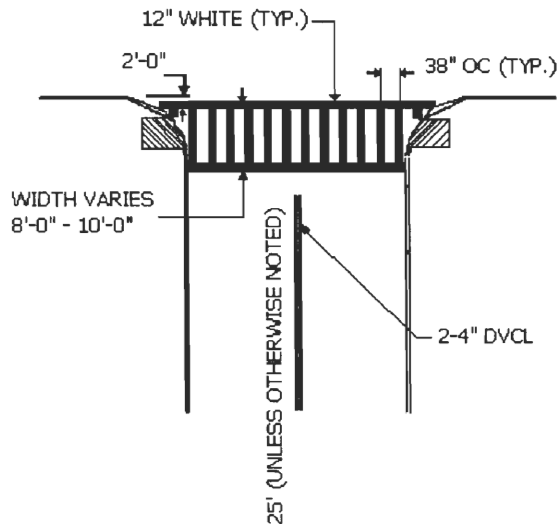

Figure 30: Uncontrolled Approach Striping Detail.¹⁸

On residential/local roadways, the width of the crosswalks at these uncontrolled locations should be 8'0'' on center. On arterial/collector roadways the width of crosswalks should be 10'0'' on center. All longitudinal lines and crossbars, regardless of their marking material, should be solid white with a width of 12''. For recommendations on what type of marking material should be used, refer to the section titled "Marking Materials".

5.2 Signage

The signage for non-signalized and signalized crossings is the same. Non-signalized intersections should have this required signage, while the signalized intersections are not required to have them. Mid-block crossings have the same basic signs, with pedestrians warning lines at each crossing required (See "Mid-Block Crossings" under the "Crosswalk Location" section for



W11A-2



W16-7

Figure 31: Pedestrian Warning Sign W11A-2 (Top) and Crossing Arrow Sign W16-7 (Bottom)

¹⁸ Design schismatic courtesy of Charles Barry, Senior Civil Engineer, Brookline Transportation Division. These specs were recently developed and have been used as unofficial standards on recent projects.

more information). The two basic signs are the Pedestrian Warning Sign W11A-2 and the Crossing Arrow Sign W16-7 (Figure 31).

5.3 Crosswalk Location

Four-way Intersections

Below are the three types of Four-way Intersections. One of the intersection types is signalized and the other two are non-signalized.

- “Traffic Signal Controlled Intersections” are intersections at which a signal controls the flow of traffic in and out of at least one approach. At all controlled approaches a crosswalk that meets the specifications described in the “Crosswalk Type” section of this report is placed (Figure 32). This is the safest placement of the crosswalk as it advises pedestrians to cross the street on approaches at which traffic stops. The placement of a traffic signal suggests high traffic volume.

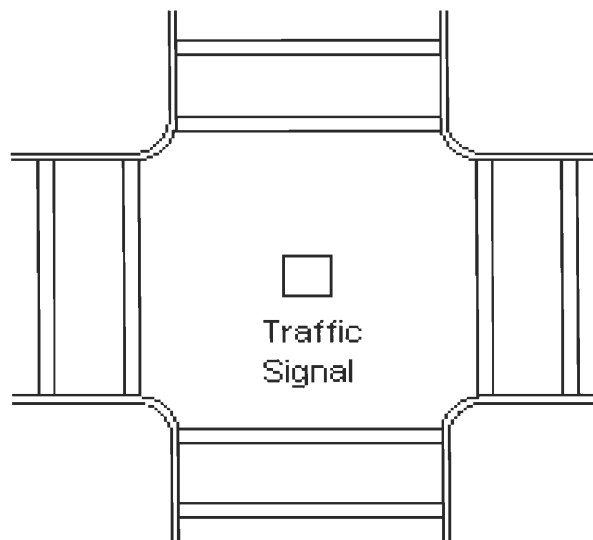

Figure 32: Traffic Signal Controlled Intersection¹⁹

¹⁹ http://www.virginiadot.org/vtrc/main/online_reports/pdf/05-r18.pdf

- “Stop or Yield Controlled Approaches” are intersections at which a stop sign or yield sign controls the flow of traffic in and out of at least one approach. At all controlled approaches a crosswalk that meets the specifications described in the “Crosswalk Type” section of this report is placed (Figure 33). This is the safest placement of the crosswalk as it advises pedestrians to cross the street on approaches at which traffic stops. The placement of a stop sign or yield sign suggests medium traffic volume.

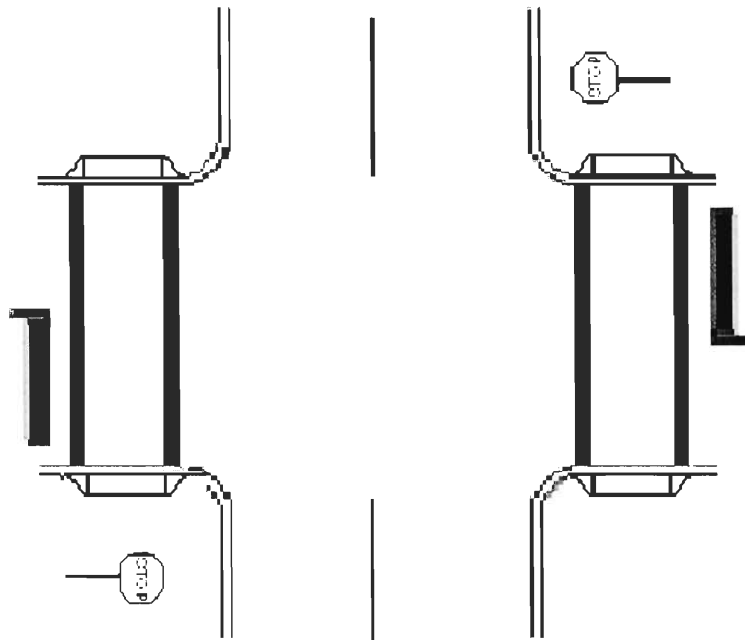

Figure 33: Stop or Yield Controlled Approach²⁰

- “Uncontrolled Intersection Approaches” are intersections at which crosswalks are placed at approaches most convenient to pedestrians. At all uncontrolled approaches a crosswalk that meets the specifications described in the “Crosswalk Type” section of this report is placed. (Figure 34) This is the safest placement of the crosswalk as it advises pedestrians to cross the street on approaches at which

²⁰ http://www.virginiadot.org/vtrc/main/online_reports/pdf/05-r18.pdf

traffic stops. The placement of a stop sign or yield sign suggests low traffic volume.

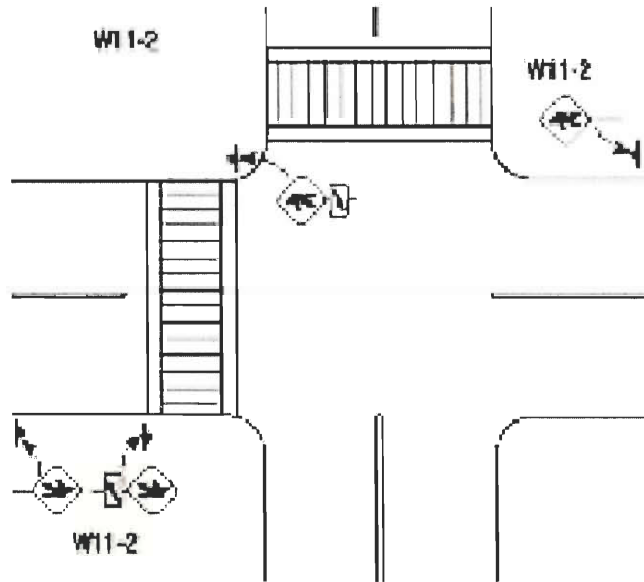

Figure 34: Uncontrolled Intersection Approach²¹

“T” Intersections

A typical “T” intersection requires at least two crosswalks, one placed at the lower portion of the “T” and the other across the left portion of the upper leg (Figure 35). The placement of crosswalks at every approach is not necessary. There is no need to have crosswalks on both sides of the T because on the roadways characteristic of Brookline this results in crosswalks being less than 50 feet apart.

A crosswalk is necessary at the lower section of the “T” because it is the only location that pedestrians can cross the street. The left portion of the upper leg will have a crosswalk because pedestrians are more visible to vehicular traffic taking left hand turns on this part of the intersection. When a vehicle takes a right hand turn onto the right portion of the upper leg, it is harder for a motorist to see and react to a crossing pedestrian since the crosswalk is very close to the turning vehicle. Vehicular traffic taking left turns from the upper right leg to the bottom of the intersection also create problems, as vehicles often try to go around the lead left-turning car. Often motorists are

²¹ http://www.virginiadot.org/vtrc/main/online_reports/pdf/05-r18.pdf

impatient and try to go around the vehicle taking the left hand turn, paying little attention to pedestrians crossing the street. Special consideration has been given to “Skewed T Intersections” where crosswalks should be perpendicular to the curb, or as close to perpendicular as possible. Perpendicular crosswalks minimize the walking distance and, therefore, the pedestrian exposure to vehicle conflicts. They also better accommodate the needs of pedestrians with visual disabilities who are usually accustomed to perpendicular crossings. The best engineering should be used and special consideration should be given to sight and stopping distances. These considerations should take priority over a perpendicular crosswalk.

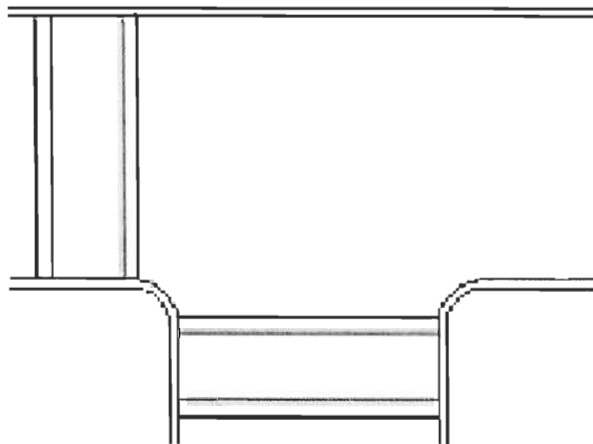

Figure 35: Typical T Intersection²²

Mid-Block Crossings

Mid-block crosswalks are not located immediately at an intersection, and they allow pedestrians to cross the street more conveniently. The same design and construction specifications apply to mid-block crosswalks and non-signalized intersections. According to Part 3 of the 2003 Manual on Uniform Traffic Control Devices (MUTCD), yield lines should be placed 20 to 50 ft (6.1 to 15 m) in advance of the nearest crosswalk line.²³

²² http://www.virginiadot.org/vtrc/main/online_reports/pdf/05-r18.pdf

²³ <http://mutcd.fhwa.dot.gov/>

Parking must also be prohibited in the area between the yield line and the crosswalk (Figure 36).

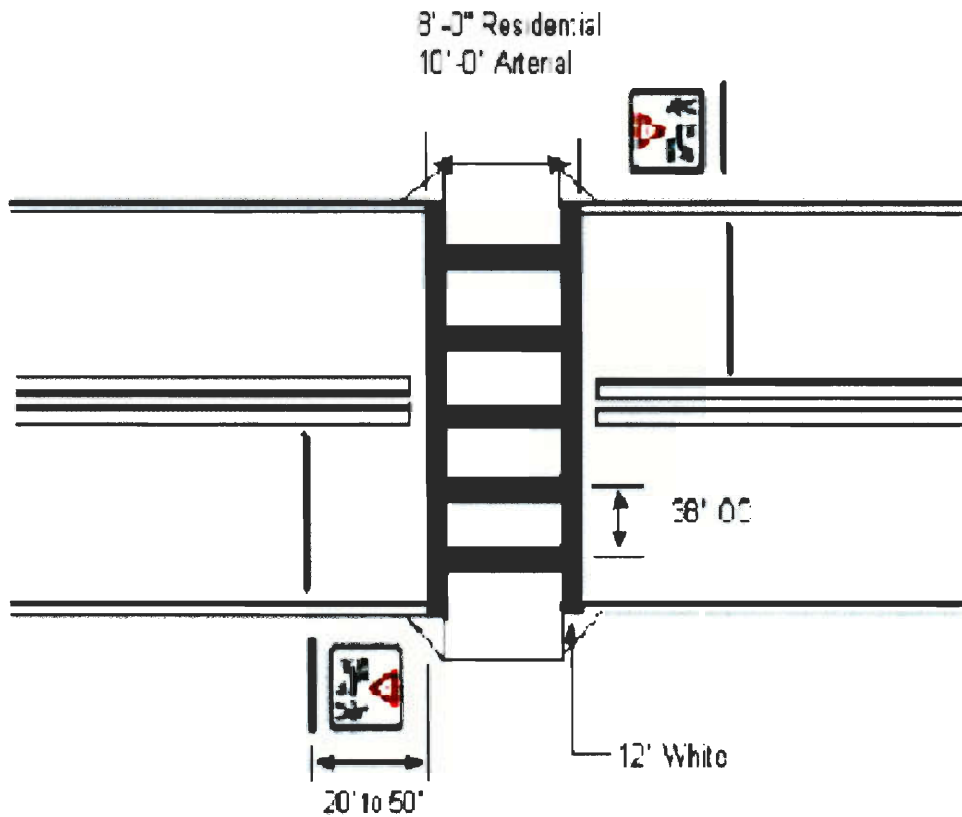

Figure 36: Mid-Block Crosswalk and Additional Signage²⁴

5.4 Crosswalk Maintenance

Road-resurfacing

When roads in Brookline are being resurfaced it is necessary that all affected crosswalks shall be reconstructed in accordance with Crosswalk Type, Crosswalk Location, and Materials sections.

²⁴ <http://mutcd.fhwa.dot.gov/>

Typical Maintenance

The condition of all crosswalks should be periodically assessed. Crosswalks in poor condition should be programmed for maintenance as soon as practical. Crosswalk maintenance should be brought into compliance with the Brookline policy as discussed in the type, location, and materials section.

Fading Away Maintenance

Crosswalks that are not included in any maintenance plan, due to impracticality of design or location, do not necessarily need to be removed. It is more cost effective to simply allow these crosswalks to fade out as traffic and weather take their toll. However, allowing crosswalks to fade out should only be employed after it has been determined that a lack of a crosswalk at this location or the presence of a crosswalk in poor condition at this location does not present any danger to pedestrians and motorists. In order to determine if a danger could occur, it would be necessary to conduct a study to create warrants for where this “fading out” technique is acceptable.

Removal

In very rare cases, if a crosswalk is determined to be a hazard or completely unnecessary then removing the crosswalk immediately may be necessary. Proper specifications as discussed in the type, location, and materials section of this report should be followed to ensure a proper crosswalk.

Brick Crosswalks

The condition of all brick crosswalks should be inventoried yearly. Any brick crosswalks lacking white perpendicular lines (standard marking pattern) should have them installed during the next maintenance cycle. Due to the low retro-reflectivity of the brick material, these perpendicular lines must be well maintained and kept in “Excellent” condition (See Section 3.4).

5.5 Maintenance Intervals

How often a crosswalk should be maintained depends upon a variety of characteristics and circumstances including: the material used, the marking pattern, the traffic and pedestrian volume, and the intended use. Each of these factors will be discussed in the following sections. The most influential factor is most likely the vehicle volume of the approach. This data is currently not available. Future collection and archiving of this data would allow for a more comprehensive maintenance plan, and increase the ability to predict when a given crosswalk may require maintenance.

Material

The material of a given crosswalk is one of the most influential factors determining how often a crosswalk should be maintained. In fact, some materials last up to ten times longer than others. At this time three materials have been identified as viable options by the Brookline Highway Department, they are chlorinated paint, thermoplastic, and inlay tape. The following is the effective lifespan of each material, as determined by the Highway Department.

Table 14: Marking material effective lifetime expectancies.

Chlorinated Paint	6 months to 1 year
Thermoplastic	1 to 3 years
Inlay Tape	5 years or more

Marking Pattern

Crosswalk type is another important factor in determining how often a crosswalk should be maintained. The data from this study indicate that ladder, zebra, and block marking patterns can be expected to perform about equally well. Though more data should be gathered with respect to the effectiveness and durability of standard type patterns, the initial data gathered suggests that this is a more maintenance friendly and cost effective marking pattern.

Intended Use

How long a crosswalk should go between remarking depends upon the acceptable level of repair or disrepair for its particular intended use. The following are recommendations for the actual acceptable condition ratings for various intended uses.

- **School Zones:** In order to ensure the safety of Brookline’s children, crosswalks within a quarter mile of all schools (or the distance away from a school that students are allowed to walk to and from school) should not be allowed to drop below a condition rating of “Good” (See Section 3.4). Ensuring the acceptable condition of these crosswalks will require periodic inventory of the crosswalk condition (Refer to the section of this report which sets these periods). Children require more guidance of where and when to cross the street, thus bright intact markings at these high volume locations are necessary.
- **Commercial Districts:** Many of Brookline’s busiest and most dangerous intersections and roadways are located in its commercial districts. Crosswalks within commercial districts should not be allowed to drop below a condition ranking of “Good” (See Section 3.4). Ensuring the acceptable condition of these crosswalks will require periodic inventorying of the crosswalk condition (Refer to the section of this report which sets these periods).
- **Residential Areas:** Brookline’s residential areas have fewer crosswalks than its commercial districts because residential areas have fewer pedestrians as well as less traffic. For these reasons it is recommended that crosswalks in residential areas are not allowed to drop below a condition ranking of “Fair” (See Section 3.4). Ensuring the acceptable condition of these crosswalks will require periodic inventorying of the crosswalk condition (Refer to the section of this report which sets these periods).

In the future, after appropriate studies have been conducted to determine how long each crosswalk type, made out of each material, at various traffic volumes can be expected to effectively last, as well as the effect of weather conditions, a more comprehensive plan for the frequency of maintenance can be created. The completion of a regression model would allow for the prediction of crosswalk condition at any point in time after the initial installation or most recent maintenance based on these variables. This would be a powerful tool when planning which locations to maintenance and also during the budgeting process.

5.6 Marking Materials

Each of the three main marking material options have their own characteristics which help to determine which material should be used at any given intersection. The three options: chlorinated paint, thermoplastic and inlay tape vary greatly in their effective lifespan and in their installation cost (Table 15). Chlorinated paint should be used to maintain existing crosswalks as needed. During roadway resurfacing and reconstruction, crosswalks should be replaced using inlaid tape. It may also be worthwhile to experiment with non-inlaid tape. Brick does not seem to be a reasonable choice for crosswalk marking material. While extremely durable, brick crosswalks have very low retro-reflectivity and often do not include the two white perpendicular lines required by the MUTCD. The material is also quite expensive and installation complicated than other materials. See Section 4 of this report for further discussion of marking material cost effectiveness.

Table 15: Materials costs and estimated durability.

	Cost	Durability
Chlorinated Paint	\$0.35 per linear foot	0.5-1 years*
Thermoplastic	\$1.30 per linear foot	1-3 years*
Inlay Tape	\$5.65 per linear foot	5+ years*

*Values are approximations that vary due to external elements.

5.7 Crosswalk Treatments

Inlaid Brick

Other than their visual appeal, brick inlay crosswalks are not very effective. They have very low retro-reflectivity and, therefore, are difficult for operators of vehicles to see during the day time and nearly impossible to detect at night. In wet conditions brick inlays become wet and slippery which could be hazardous to both pedestrians and motorists. On top of the already mentioned drawbacks, brick inlay is an expensive crosswalk treatment. This treatment should be avoided if possible.



Figure 37: Example of an inlaid brick crosswalk.

Raised Crosswalks

Originally thought to act as a speed inhibitor while making the pedestrian more visible to motorists, raised crosswalks (Figure 11) have been found to be somewhat of a nuisance. They make snow removal difficult and judging by the landing marks found in the pavement on either side of these crosswalks, they have damaged many a suspension and undercarriage. The extremity of raised crosswalks, limit their use to such confined roadways that it makes the high installation cost unreasonable. These crosswalks also require a large amount of marking material to mark the yield lines on the approach for motorists. It is likely that the amount of material needed to make these markings is near the amount needed to mark a crosswalk, and that these yield markings have a similar lifespan. If a raised crosswalk treatment is thought to be necessary at a given location, other traffic calming measures should first be explored. More signage in and off the roadway, flashing pedestrian signals, and yield lines are all safer and more cost effective traffic calming measures.

Curb Extensions

Curb extensions are a useful method of solving sight distance and visibility issues that may occur at an approach with parking near the crosswalk (Figure 10). This treatment also aids pedestrians by reducing the distance required to cross the roadway, and help to prevent vehicles from blocking access to the crosswalk. The installation of this treatment is most easily done during roadway reconstruction or sidewalk reconstruction, and is somewhat costly. For these reasons this treatment should be reserved for dangerous locations, locations where the crossing spans 3 or more lanes, locations in close proximity to curbside parking, and locations of very high traffic volume. “Double threat” (Figure 4) and mid-block crossings (Figure 5) are also candidates for this treatment. There is no need to install curb extensions on an approach with low pedestrian and vehicular traffic volumes.

6. Conclusions

The use of a crosswalk inventory and information database proved to be a very effective way to identify and analyze problems with the current pedestrian crosswalk network in Brookline and to quickly plan possible solutions. The database also facilitated the production of cost estimates and other calculations that were impossible to make before this study. The continued use of this database and the completion of the inventory will allow Brookline officials to accurately assess and plan for needed maintenance, as well as have a full understand of exactly what the current status, condition, and problems of the various general and specific locations are.

The total amount of crosswalk inventoried was calculated to be over 103,500 linear feet (19.6 miles) spread over 393 crossings. Of all these crosswalks, 227 (58%) were found to be in “Poor” condition, and many of these are within a quarter mile of a school. The prevalence of the poor condition suggests that the current budget is not adequate for proper crosswalk maintenance and that this budget should be significantly increased to allow for the painting of existing crosswalks. A possible long-term solution would be to identify a long lasting material, possibly an inlayed marking tape, and to install it at crosswalk locations as roadways are resurfaced.

The implementation of the policy recommendations made would help to standardize crosswalks in the town, and would also reduce the overall amount of material used, thus improving efficiency and saving the town money. Several locations in the town require excess material and eliminating the use of this material through the removal of extra crossings at 9 T intersections and the use of standard marking patterns at 32 signalized intersections would remove a sizable amount of material from the maintenance cycle. Added to this would be the amount of material to be removed by converting all non-signalized, controlled approaches to a standard marking pattern. The data show that a doubling of the current budget would be the first major step towards improving marking quality and condition, but that a long term financial plan for the installation of more durable materials at all crossings such as the one proposed in this report is needed.

7. Bibliography

1. Federal Highway Administration, "The Manual on Uniform Traffic Control Devices." <http://mutcd.fhwa.dot.gov/>
2. Vermont Agency of Transportation, "Guideline for the Installation of Crosswalk Markings and Pedestrian Signing at Marked and Unmarked Crossings." <http://www.aot.state.vt.us/progdev/Documents/TrafficOperations/Crosswalk%20Guidelines%202004.pdf>
3. Massachusetts Highway Department, "Highway Design Manual." <http://166.90.180.162/mhd/downloads/manuals/design.pdf>
4. Dougald, Lance E., "Development of Guidelines for Installation of Marked Crosswalks." The Virginia Department of Transportation http://www.virginiadot.org/vtrc/main/online_reports/pdf/05-r18.pdf
5. Lagerwey, Peter and Jennifer Hefferan. "The City of Seattle, WA, YSA, crosswalk inventory and improvement plan." ITE Journal (Institute of Transportation Engineers). 74, no. 1 (2004): 42-46.
6. Lagerwey, Peter, Megan Hoyt, and Jennifer Hefferan. "Improvement Plan for Uncontrolled Marked Crosswalks." December 2002. Obtained by email: Pete.Lagerwey@Seattle.Gov
7. Boodlal, L. "Accessible Sidewalks and Street Crossings – An Informational Guide." National Technical Administration Service. No volume (2004): 1-41.
8. Campbell, B.J., et al. "A Review of Pedestrian Safety Research in the United States and Abroad." North Carolina: Highway Safety Research Center, University of North Carolina. January, 2004.

9. Miller, S, GK Rousseau, and AH Do. "Seeing Crosswalks in a New Light." *Public Roads*. 77, no. 4 (2004): 15-17.
10. Carmen Hass-Klau, *The Pedestrian and City Traffic*, New York: Belhaven Press, 1990.
11. Ullman, B, K. Fitzpatrick; N. Trout. "On-Street Pedestrian Surveys of Pedestrian Crossing Treatments." *Institute of Transportation Engineers: 2004 Annual Meeting and Exhibit*. No Volume (2004): 1-15.
12. Huang, H. and C. Zegeer. "Effects of innovative pedestrian signs at insignalized locations: Three treatments." *Transportation Research Record* no. 1705 (2000): 43-52.
13. Kannel, Edward J. and William Jansen. "In-Pavement Pedestrian Flasher Evaluation: Cedar Rapids, Iowa." Iowa: Center for Transportation Research and Education, Iowa State University. April, 2004
14. Papageorgiou, Markos. "Concise Encyclopedia of Traffic & Transportation Systems." Pergamon Press, 1991.
15. Zegeer, Charles V. J. Richard Stewart, Herman Huang, *Safety Effects of Marked and Unmarked Crosswalks at Uncontrolled Locations: Executive Summary and Recommended Guidelines*, Federal Highway Administration, November 2000.
<http://safety.fhwa.dot.gov//fourthlevel/pdf/Cros.pdf>
16. ADA Homepage, <http://www.usdoj.gov/crt/ada/adahom1.htm>

17. City of Stockton, CA Public Works, Pedestrian Safety and Crosswalk Installation Guidelines, November 2003.
<http://www.stocktongov.com/publicworks/publications/PedGuidelines.pdf>
18. Insurance Institute for Highway Safety. "What Works and What Doesn't to Reduce Pedestrian Crashes." Status Report 39, no. 6 (2004): 1-8.
19. Partnership for a Walkable America, <http://www.walkableamerica.org/>
20. Swedish Traffic Conflict Technique, <http://www.tft.lth.se/research/Traf.htm>
21. Garson, David. "PA765 Multiple Regression."
<http://www2.chass.ncsu.edu/garson/pa765/regress.htm>
22. "First Sign", <http://firstsign.com/index.php?cPath=34>
23. "Design a Sign", <http://designasign.biz/traffic-signs-303-Traffic+Warning+Signs+With+Words+Only.html>

Appendix A: Mass Highway Directive

This is a copy of Mass Highway Engineering Directive I-96-001 discussing the standardization of Massachusetts crosswalk markings.



Number: I-96-001

Date: 3/26/96

ENGINEERING DIRECTIVE

Thomas S. Brubaker, P.E.
CHIEF ENGINEER

STANDARDIZATION OF CROSSWALK MARKINGS

The Department is responsible for installation and maintenance of crosswalk markings in accordance with the guidelines provided in the MUTCD and the Highway Design Manual. However, these references give only general information regarding such markings.

The purpose of this directive is to provide specific requirements to be followed for the installation of crosswalk markings on state highways.

Effective immediately, crosswalk markings provided as part of any project shall conform to the following:

- 1) The standard crosswalk marking used on the state highway system shall be the 'TYPE A' marking as detailed in Figure 3 - 14 of the MUTCD.
- 2) The standard line width of the markings shall be three hundred (300) millimeters.
- 3) The width between crosswalk lines should be no less than two (2) meters.
- 4) Where provided, stop lines should be placed no less than 1.25 (one and one-quarter) meters behind an adjacent crosswalk line.
- 5) Isolated crosswalks shall not be installed in areas with a sight distance less than the minimum required under Table 3.11 STOPPING SIGHT DISTANCE in the MED Highway Design Manual.

This directive applies to new crosswalk installations at state highway locations and in state-funded projects. However, if a municipality has adopted a local standard which is in conformance with the MUTCD, it may be incorporated into state-funded projects which do not involve state highway.

Distribution: 3 Please post: _____ Do not post X

Page missing or incorrectly
numbered in original

IQP/MQP SCANNING PROJECT



George C. Gordon Library
WORCESTER POLYTECHNIC INSTITUTE

Appendix B: Data Collection Forms

The following is a blank copy of the field form used to inventory crosswalks at the intersection of Aspinwall Ave. and Kent St.

Page 1:

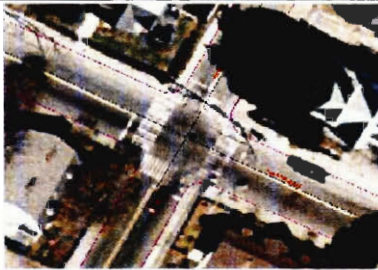
Brookline Crosswalk Inventory		Location ID: _____ page 1 of 4		
Location	Location ID: ASPINWALL AVE KENT ST	East/West Street:	Survey staff:	
	Date performed: / / 05	North/South Street:		
	Aerial Photo: 	Notes:		
Photo of Crosswalk	Approach 1	Approach 2	Approach 3	Approach 4

Page 2:

Brookline Crosswalk Inventory		Location ID: _____ page 2 of 4				
@ Intersection	Check if present:	Approach 1	Approach 2	Approach 3	Approach 4	Notes
	Traffic Signal					
	Pedestrian Signal					
@ Midblock	Check if present:					
	Pedestrian Signal					
	ADA ramps					
Street on Approach	Check if present:					
	Raised median/island					
	One-way street					
	School zone flashers					
	Street lamp (within 20')					
	Check if present or provide measurement:					
	No. of travel lanes					
Sidewalk on right side						
Sidewalk on left side						
Parking on right side						
Parking on left side						
Posted speed limit						
Bus stop						

Brookline Crosswalk Inventory		Location ID: _____				
		page 3 of 4				
Check pattern (see key below):		Approach 1	Approach 2	Approach 3	Approach 4	Notes
Pattern	Perpendicular (Standard)					
	Parallel Bars (Block)					
	Zebra (Diagonal)					
	Ladder					
	Solid					
	Brick Inlay					
Other (identify):						
Dimensions	Provide measurement:					
	Width of crosswalk					
	Width (ft) and color of perp. lines					
	Spacing of bars on center(ft)					
	Width (ft) and color of bars					
	Distance (ft) stop bar from crosswalk					
	Width (ft) of right sidewalk					
Width (ft) of left sidewalk						
Materials	Check material used:					
	Epoxy paint					
	Thermoplastic					
	Inlay tape					
	Other (identify):					

Key to Crosswalk Patterns:



Brookline Crosswalk Inventory		Location ID: _____				
		page 4 of 4				
Check condition (see key below):		Approach 1	Approach 2	Approach 3	Approach 4	Notes
Condition	Excellent					
	Good					
	Fair					
	Poor					
Check if present:						
Treatment	Curb extensions					
	Center island					
	Raised crosswalk					
	Flashing yellow lights					
	Pedestrian signal					
	Portable YTP sign					
Other (identify):						
Check if present (see key below):						
Signs	Crosswalk Sign (W11A-2)					
	Arrow sign (W16-7p)					
	Advance ped warning (W11-2)					
	Yield to pedestrian					
	Other (identify):					

Key to Crosswalk Condition:

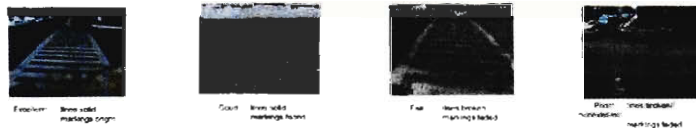

Key to Signs:



Appendix C: T Intersections

The map below shows a section of Brookline near the intersection of Harvard St. and Washington St. Crosswalk locations are shown in yellow. Red indicates a redundant crossing at a T intersection and these locations are circled.

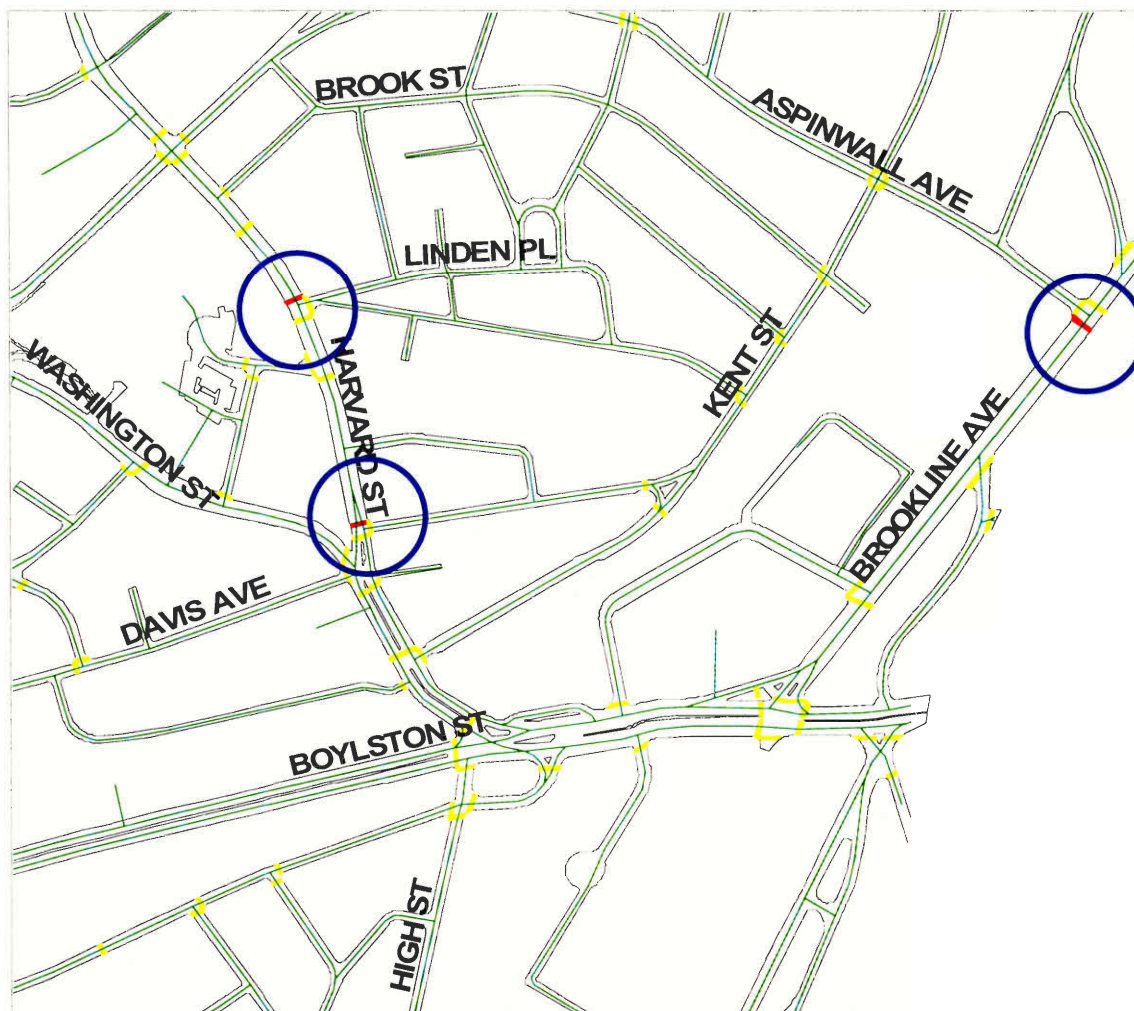

Appendix D: Signalized Intersections

The map below shows an area of Brookline north of the intersection of Harvard St. and Beacon St. Crosswalk locations are shown in yellow. Crosswalks at signalized intersections with a ladder, zebra, or block marking pattern are shown in red.

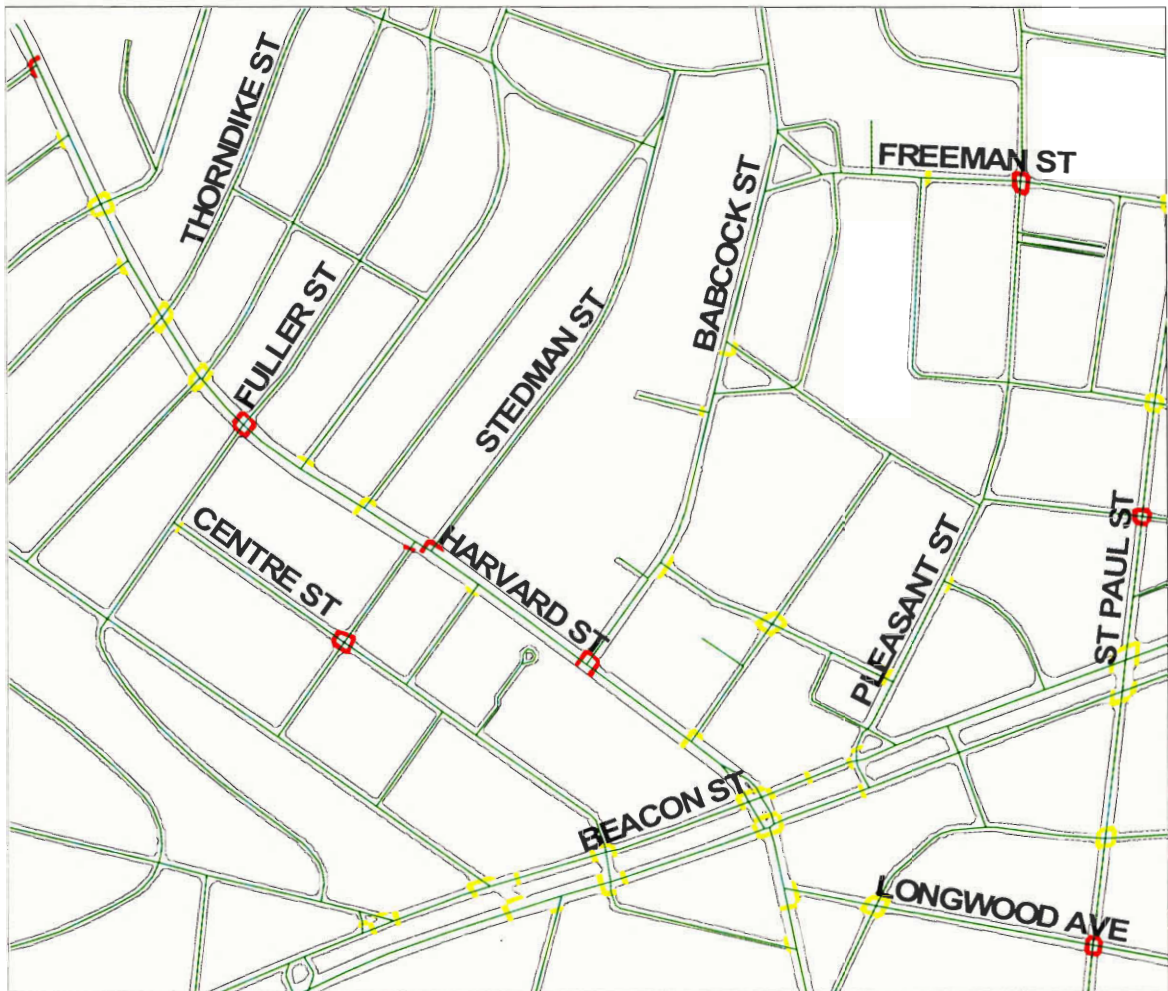

Appendix E: School Zones

Map of northern Brookline between Beacon St. and Boylston St. showing the location of schools and crosswalk conditions. School zones extend a quarter mile from the school.

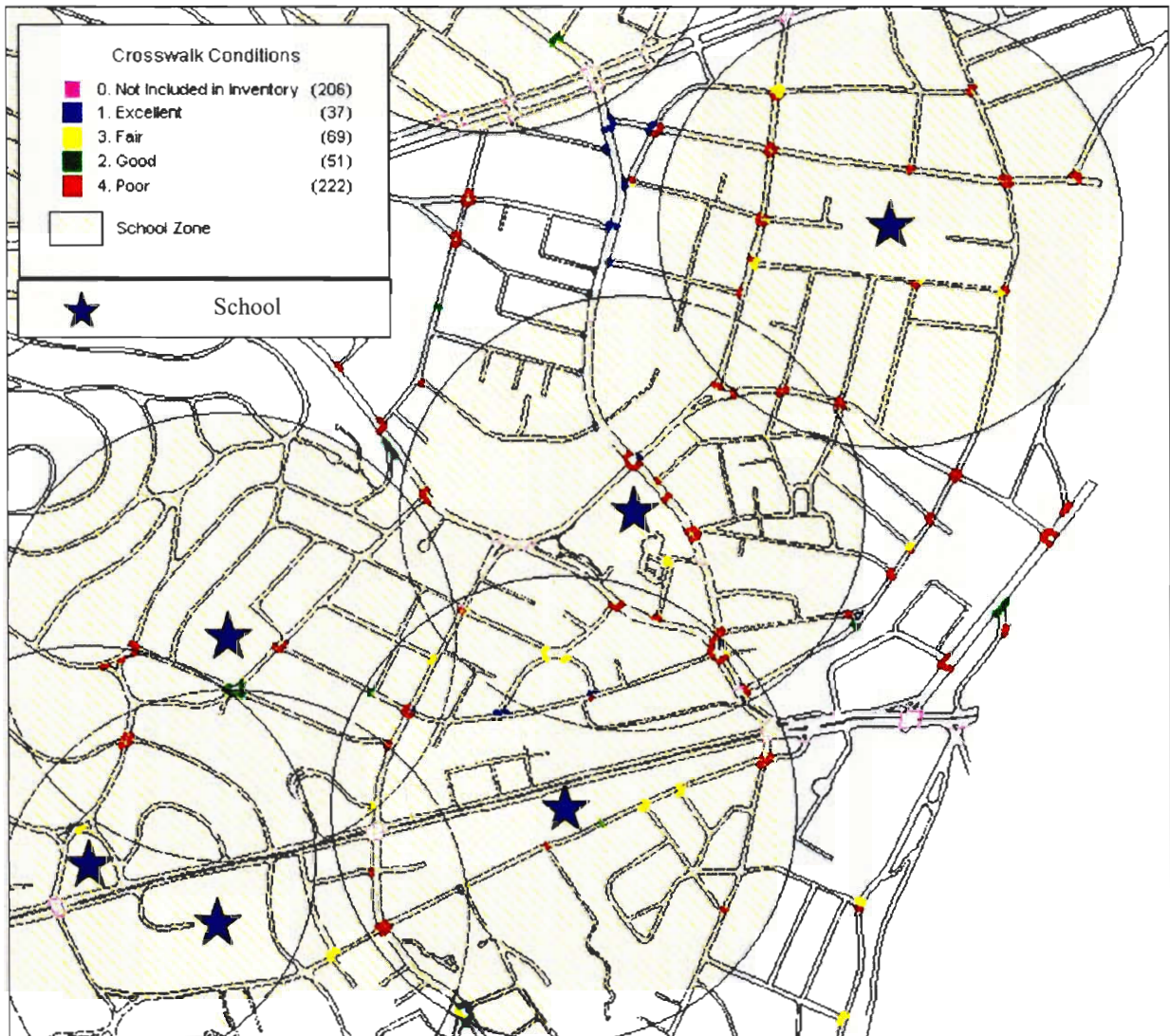

Appendix F: Pattern Map

The map below shows the northern half of Brookline and the locations of all crosswalks. Inventoried crosswalks are color-coded by marking pattern and these values are shown in the legend.

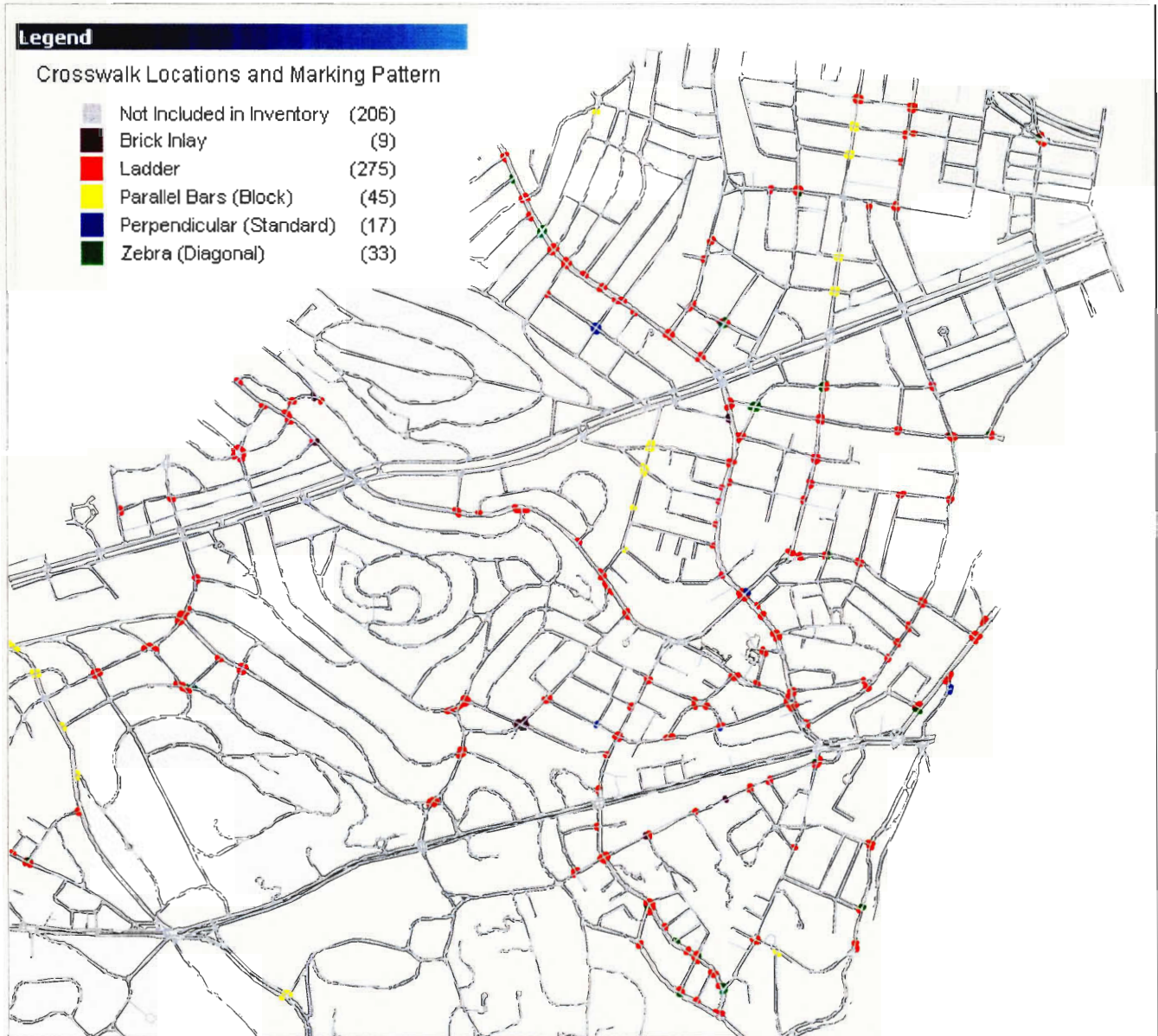

Appendix G: Condition Map

The map below shows the northern half of Brookline and the locations of all crosswalks. Inventoried crosswalks are color-coded by marking condition and these values are shown in the legend.

