

## PRELIMINARY DATA WAVELENGTH SENSOR AND CIRCUIT WS-7.56-PCBA2

The PSS-WS-7.56-PCBA is a unique wavelength sensor based on silicon photodiode technology. The sensor is constructed monolithically by superimposing two photodiodes vertically. The active area is 7.56mm<sup>2</sup> (2.7mm x 2.7mm). This device is most useful for wavelength determination of monochromatic light sources such as lasers and LED's. More information on the sensor is available on this web site under "Wavelength Sensitive Photodiodes".

The sensor is mounted on a PCB as shown with all the necessary circuitry to convert incident wavelength to an output voltage. The voltage is proportional to wavelength in the range of 450nm to 900nm. The output is independent of intensity. The circuit provides switched gain controls to accommodate various output requirements. As an example a typical output is 1.7 volts for a wavelength of 670nm, with a gain setting of 5. The data in this sheet provides typical information. The actual output must be calibrated against know sources for accuracy. Resolution of 0.01nm is possible. The circuit requires ±15 volts and consists of two logarithmic amplifiers and a ratio calculator. The sensor is mounted on a temperature monitor for reference. Applications include laser monitoring, matching of LED's and other light sources.

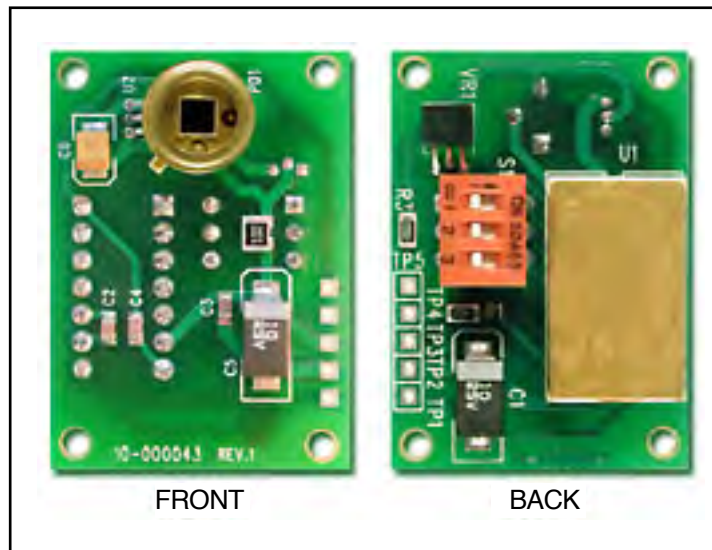

CIRCUIT REQUIREMENTS						
SUPPLY VOLTAGE			SUPPLY CURRENT	TEMPERATURE CURRENT	INPUT DYNAMIC RANGE	OPERATING TEMPERATURE
Minimum	Typical	Maximum	Typical = +20MA	Output Current Limit 10MA	10μw to 3MW	-20° to +55°C
±12.0V	±15.0V	±18.0V				

## WAVELENGTH SENSOR AND CIRCUIT WS-7.56-PCBA2

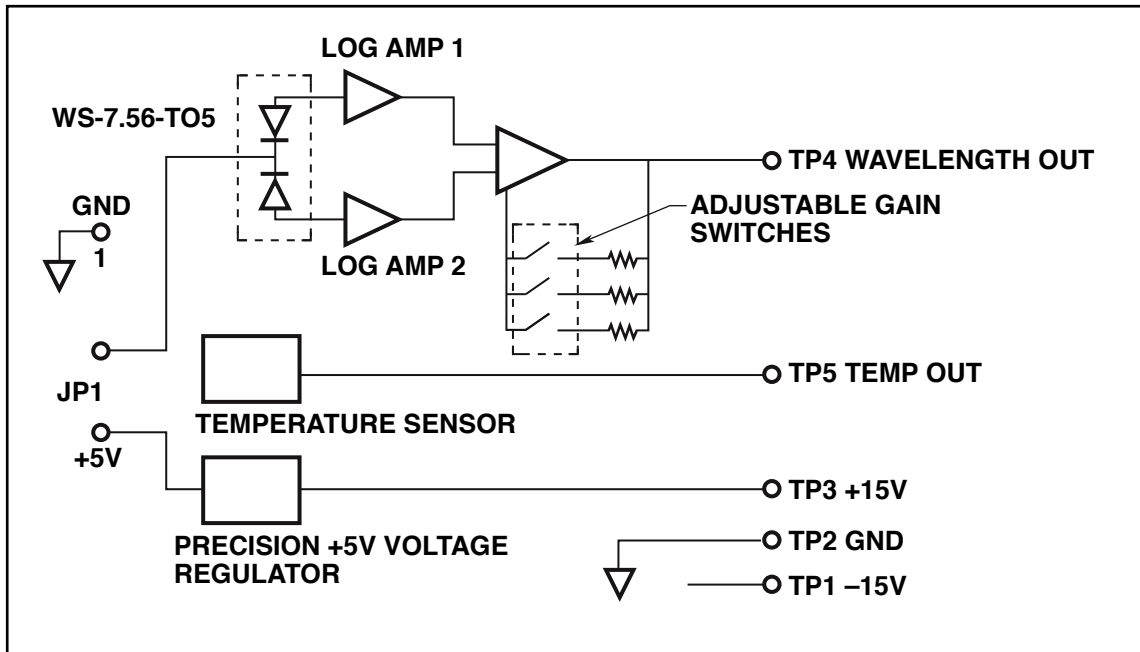

**SCHEMATIC DIAGRAM**

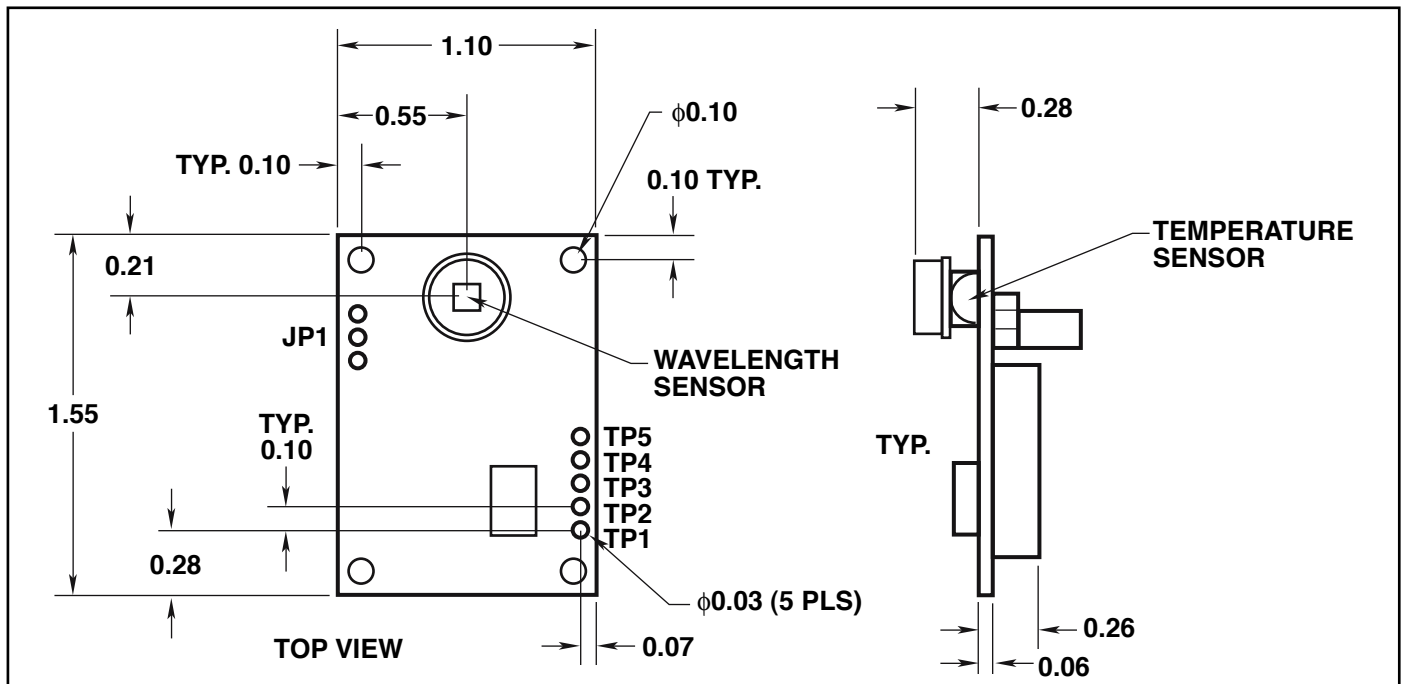

**OUTLINE DIMENSIONS (Inches)**

## WAVELENGTH SENSOR AND CIRCUIT WS-7.56-PCBA2

### DESCRIPTION

The PSS WS-7.56-PCBA is circuit board complete with a precision wavelength sensing diode array, a precision temperature sensor and processing circuitry. Two output signals are 1) a voltage output proportional to the wavelength of the light sensed by the photodiode array and 2) a voltage output proportional to the temperature of the case of the photodiode array. The photodiode array is made using silicon technology. The PSS-WS-7.56-PCBA is rated for the wavelength range of 450nm to 950nm. It is best suited to determine the wavelength of monochromatic light.

### OPERATION

The magnitude of the wavelength voltage output is controlled by three slide switches that change the gain of the amplifier. The gain ranges are shown in Table 1.

GAIN	SWITCH POSITIONS	
	ON	OFF
5.0	3	1 & 2
3.0	2	1 & 3
1.9	3 & 2	1
1.0	1	3 & 2

Table 1. GAIN ADJUSTMENT

Figure 1 shows the typical output voltage versus wavelength for a gain of 1. Figure 2 shows the response for a gain of 3. Figure 3, gain of 5. The voltage out will be relative to the spectral density center. That is, the actual output voltage will be related to the integral of the combination of the spectral response curve and the spectral content of the light input. Assuming the light input is very near a single wavelength (i.e., assuming a good laser source) the voltage out will be a good analog of the wavelength of the light source. Under optimum conditions of light intensity and wavelength spectral resolutions down to 0.01nm are possible.

### DETECTOR CHARACTERISTICS

The detector used is the PSS WS-7.56-TO5. Please see the specifications for this detector for details of the detector response.

### TEMPERATURE CONSIDERATIONS

The PSS-WS-7.56-PCBA operating temperature range is  $-20^{\circ}\text{C}$  to  $+55^{\circ}\text{C}$ . The wavelength output has a temperature dependence of 1nm per degree C.

The circuitry also includes a precision temperature sensor. This sensor allows users to calibrate the wavelength output based on the temperature of the wavelength detector. The temperature sensor output is 10mv per degree C, and is typically accurate to  $\pm 0.25^{\circ}\text{C}$ . The range of the temperature sensor is from  $+2^{\circ}\text{C}$  to  $+150^{\circ}\text{C}$ .

### DETECTOR BIAS

The circuitry provides internal 5 volt bias to the photodiode array.

### FREQUENCY RESPONSE

The amplifier used is a logarithmic amplifier and consequently the frequency response is a function of the input signal amplitude. For typical input signals in the 0.5 milliwatt range and wavelengths in the range of 480nm to 1000nm the cutoff ( $-3\text{db}$ ) frequencies will be approximately 10kHz.

## WAVELENGTH SENSOR AND CIRCUIT WS-7.56-PCBA2

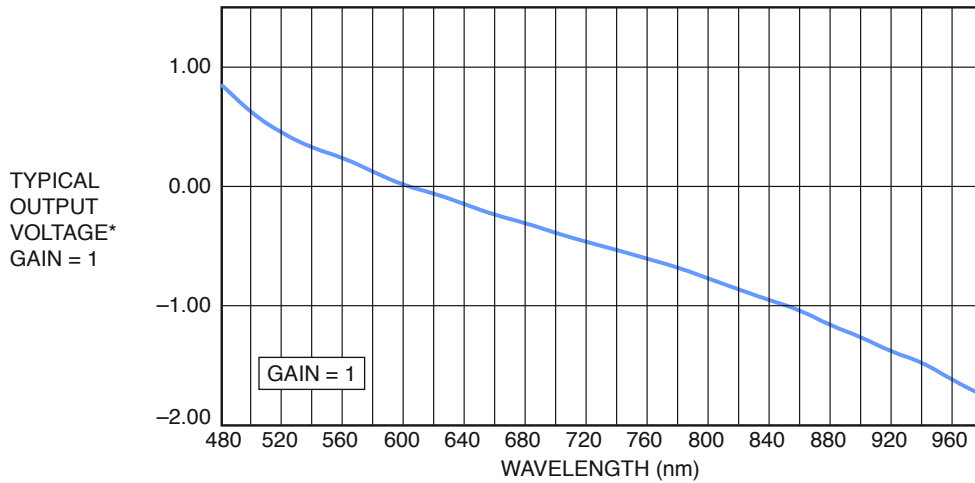

FIG.1 VOLTAGE OUT VS WAVELENGTH @ 22°C

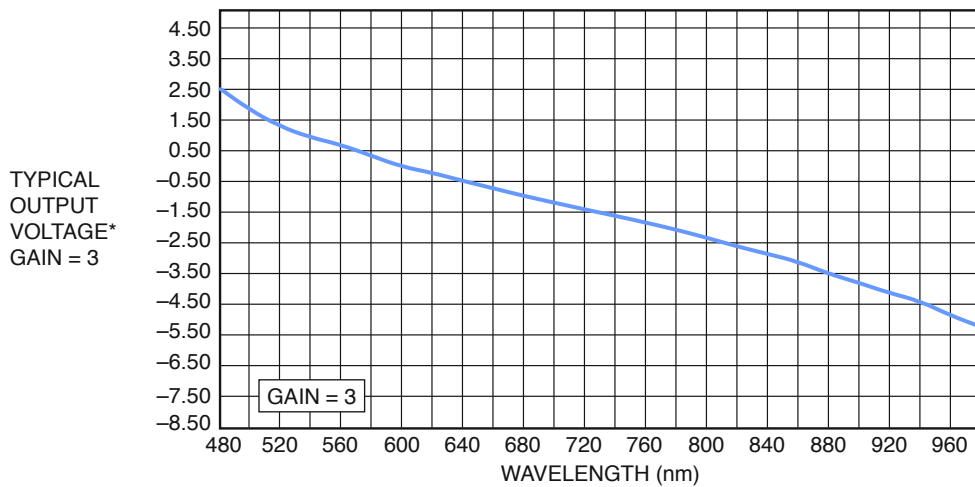

FIG.1 VOLTAGE OUT VS WAVELENGTH @ 22°C

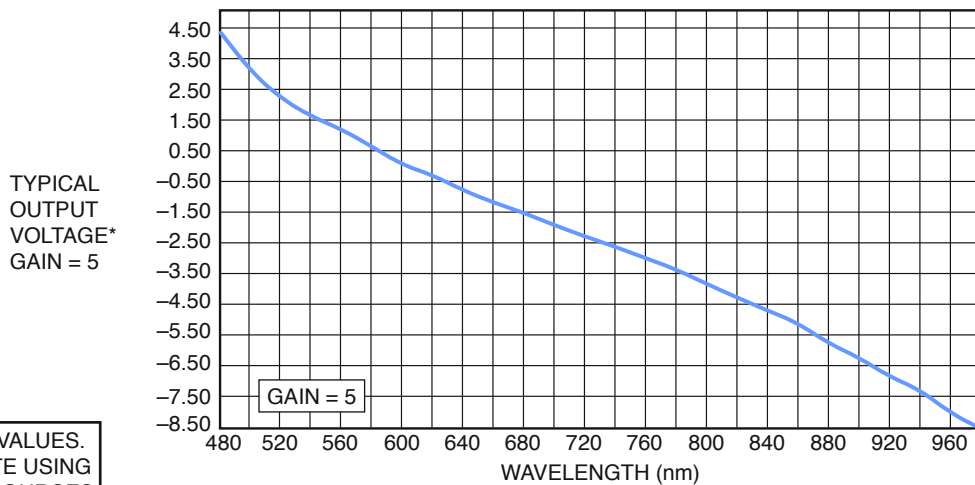

FIG.1 VOLTAGE OUT VS WAVELENGTH @ 22°C

\* TYPICAL VALUES.  
CALIBRATE USING  
KNOWN SOURCES.