

2016-2017 Design and Optimization of a SAE Baja Chassis

A Major Qualifying Project Report

submitted to the Faculty of

WORCESTER POLYTECHNIC INSTITUTE

in partial fulfillment of the requirements for the

Bachelor of Science Degree

in Mechanical Engineering

By

Heather Selmer, ME

Sabbrin Shweiki, ME

Paige Tencati, ME

Date:

April 20th, 2017

Approved By:

Prof. David C. Planchard, Project Advisor

Prof. John R. Hall, Project Co-Advisor



WPI



Table of Contents

| | |
|-----------------------------|----|
| Table of Figures | 1 |
| List of Tables | 2 |
| List of Equations | 2 |
| Nomenclature | 3 |
| Abstract | 4 |
| Acknowledgements | 5 |
| Introduction | 6 |
| Project Overview | 6 |
| SAE Overview | 7 |
| What is a Baja vehicle? | 8 |
| Background Research | 9 |
| Vehicle Subsystems | 9 |
| Frame | 9 |
| Suspension | 10 |
| Wheel Alignment | 12 |
| Methods and Procedure | 18 |
| Design Specifications | 18 |
| Design Analysis | 19 |
| Suspension System | 19 |
| Front Suspension Design | 21 |
| Rear Suspension Design | 21 |
| Transmission | 22 |
| Torque Goal | 22 |
| Frame | 24 |
| Design Iterations | 24 |
| Conclusion | 41 |
| Future Work and Suggestions | 43 |

| | |
|--|-----|
| Appendices | 44 |
| Appendix A: Baja SAE Vehicle with Subsystems | 44 |
| Appendix B: Elongated Design Simulations | 45 |
| Appendix C: Final Design Simulation Reports | 59 |
| C1: Frontal Impact 1 | 59 |
| C2: Frontal Impact 2 | 68 |
| C3: Rear Impact | 76 |
| C4: Rollover | 84 |
| C5: Drop Impact | 92 |
| C6: Side Impact | 100 |
| C7: Top Impact | 108 |
| C8: Driver and Engine Drop | 116 |
| Works Cited | 124 |

Table of Figures

| | |
|---|----|
| <i>Figure 1 Primary and Secondary Member Classification</i> | 10 |
| <i>Figure 2 Coil Over Shock Absorber</i> | 11 |
| <i>Figure 3 Air Shock Absorber</i> | 12 |
| <i>Figure 4 Camber angle</i> | 13 |
| <i>Figure 5 Caster</i> | 14 |
| <i>Figure 6 Toe configuration (as viewed from the top)</i> | 15 |
| <i>Figure 7 SAI / KPI</i> | 16 |
| <i>Figure 8 RIT's 2016 Vehicle Showing Double A-Arm in the Front Suspension</i> | 20 |
| <i>Figure 9 Front suspension design</i> | 21 |
| <i>Figure 10 Rear Suspension Design</i> | 22 |
| <i>Figure 11 Free Body Diagram of Baja for Hill Climb Event</i> | 23 |
| <i>Figure 12 Rounded Square Nose Model of First Frame Design</i> | 24 |
| <i>Figure 13 Rounded Square Nose Model Front Impact Four Points Static Force Simulation and Stress Key</i> | 26 |
| <i>Figure 14 Square Nose Model Close-up of Front Impact Four Points Static Force Simulation</i> | 27 |
| <i>Figure 15 Rounded Bottom Nose Frame Design</i> | 27 |
| <i>Figure 16 Rounded Bottom Nose Model Front Impact Four Points Static Force Simulation and Stress Key</i> | 28 |
| <i>Figure 17 Rounded Bottom Model Close-up of Front Impact Four Points Static Force Simulation</i> .. | 28 |
| <i>Figure 18 Welded Square Nose Model Frame Design</i> | 29 |
| <i>Figure 19 Welded Square Nose Model Front Impact Four Points Static Force Simulation and Stress Key</i> | 30 |
| <i>Figure 20 Welded Square Nose Model Front Impact Two Points Static Force Simulation and Stress Key</i> | 30 |
| <i>Figure 21 Welded Square Nose Model Modified</i> | 31 |
| <i>Figure 22 Elongated Welded Square Nose Model</i> | 31 |
| <i>Figure 23 Elongated Welded Square Nose Model Front Impact Four Points Static Force Simulation and Stress Key</i> | 32 |
| <i>Figure 24 Elongated Welded Square Nose Model Front Impact Two Points Static Force Simulation and Stress Key</i> | 32 |
| <i>Figure 25 Elongated Frame Design with Front Tabs</i> | 33 |
| <i>Figure 26 Percy and C10</i> | 34 |
| <i>Figure 27 Front Impact Simulation</i> | 35 |
| <i>Figure 28 Front Bottom Impact Simulation</i> | 35 |
| <i>Figure 29 Rollover Simulation</i> | 36 |
| <i>Figure 30 Rear Impact Simulation</i> | 36 |
| <i>Figure 31 Top Impact simulation</i> | 37 |
| <i>Figure 32 Drop Impact Simulation</i> | 37 |
| <i>Figure 33 Northeastern Baja tabs</i> | 39 |
| <i>Figure 34 Initial tab models</i> | 40 |
| <i>Figure 35 MQP's Northeastern style tab</i> | 40 |
| <i>Figure 36 Variable tab model</i> | 41 |

List of Tables

| | |
|--|----|
| <i>Table 1 Nomenclature</i> | 3 |
| <i>Table 2 Male/Female Driver Parameters</i> | 19 |

List of Equations

| | |
|--|----|
| <i>Equation 1 Torque</i> | 23 |
| <i>Equation 2 Maximum force</i> | 25 |
| <i>Equation 3 Factor of safety and applied force</i> | 25 |

Nomenclature

Table 1 Nomenclature

| Symbol | Name | Unit |
|---|--|---|
|  | Center of mass | |
| m | Mass | kg |
| g | Gravitational acceleration | m/s ² (9.81 m/s ²) |
| g _x | Gravitational acceleration in the x (horizontal) component | m/s ² |
| g _y | Gravitational acceleration in the y (vertical) component | m/s ² |
| a | Acceleration | m/s ² |
| t | Time | s, seconds |
| W | Weight | N (Newtons) |
| T | Torque (rotational force in mechanics) | N·m |
| D | Diameter | m, meter |
| r | Radius | m |
| F _f | Force of friction | N |
| F _N | Normal force | N |
| F _w | Force of work (force put by the engine, etc.) | N |
| θ | Angle | ° (degrees) |
| hp | Horsepower | hp = 746 W (Watts) |

Abstract

The purpose of the Society of Automotive Engineers (SAE) Baja Major Qualifying Project (MQP) was to analyze the pre-existing Baja SAE (BSAE) vehicles to determine flaws and design a new chassis that improved upon the previous designs. This MQP identified particular problems with the size of the engine compartment, the overall suspension alignment and attachment points, as well as the visibly crooked nature of the vehicle. After consideration of possible solutions, the MQP created various preliminary designs utilizing the Baja SAE Rules as a guide for design decisions. Basic Finite Element Analysis (FEA) was conducted on the preliminary designs to determine which performed best in a head-on collision. Stress and deflection analyses in multiple scenarios were conducted on a design similar to the final design and changes were made accordingly until the frame could withstand the many rigors that a vehicle would endure during a Baja SAE competition. When designing the suspension, the MQP determined that a double A-arm would be suitable in the front and a trailing A-arm would be best in the rear. Each was designed using specific constraints. A quote to manufacture and weld the frame was requested from VR3 and all documentation needed was created so that the manufacturing process could be completed during the upcoming summer. Sound engineering design and analysis allowed this MQP to produce a chassis that will give an exceptional performance in future competitions.

Acknowledgements

Our team would like to express our sincere gratitude to the following individuals and organizations for their invaluable help and support throughout our project:

- Professor David C. Planchard from the Mechanical Engineering Department at WPI for serving as our main project advisor. His guidance and continuous involvement, from its initial stages to its full completion, was indispensable to the project's development and success.
- Professor John R. Hall from the Mechanical Engineering Department at WPI for serving as our co-advisor. He challenged our thought process and helped us better understand the reasoning behind certain assumptions and calculations.
- Members of the SAE chapter at WPI
- VR3 Engineering Ltd., Cartesian Tube Technology; they provided a quote for the manufacture and welding of the frame.
- Members, especially Dan Polnerow, from the SAE club at Northeastern University
- 2016-2017 Formula MQP members, especially Jonathan Ross and Christian Strobel
- Previous 2015-2016 SAE Baja MQP members. They particularly helped with the transfer of knowledge, which allowed for a smooth transition into the project.
- Bertan Atamer, team member of the 2013-2014 SAE Baja MQP
- Zachary Sears and James Waldo, team members of the 2015-2016 SAE Formula MQP
- Steven Murphy, WPI ME student and Solidworks Expert consultant
- Patrick Bemben, former team member and WPI student

Introduction

Project Overview

Students of Worcester Polytechnic Institute (WPI) for the past many years have developed a vehicle for the Society of Automotive Engineers (SAE) Baja competition as part of their Major Qualifying Project (MQP). WPI students try to go to the Baja SAE competition every two years, however, continuous MQP changes have impeded WPI's participation in the competition. Every year the MQP team conducts various modifications in order to optimize the vehicle.

The Baja SAE competition consists of many dynamic events, including a 100 foot acceleration, a hill climb or traction challenge, maneuverability, endurance, and specialty events (dependent on chosen course) such as a rock crawl, mud bog, or suspension challenge. The car must be designed to be rugged enough to compete in and satisfactorily complete all dynamic events. The Baja SAE competition expects the car to be designed and built using proper engineering practices, and there are many things to be done to ensure the car is safe to drive. The team must ensure that all rules are followed without exception so that the car is able to compete and the driver remains safe while doing so.

This MQP, in collaboration and partnership with the project advisor and co-advisor, industry experts, and WPI collegiate SAE Chapter, heavily focused on redesigning the frame of the vehicle. Previous MQPs have used a frame already built by the year before them, the last version being the one designed by the MQP in the academic year of 2013-2014. Due to the extensive modifications that would be needed to ensure that the existing frame was competition worthy, the team decided that it was more practical to create a new frame. The team conducted research to determine what the frame needed to be able to accomplish and withstand, along with methods and design components that other BSAE teams have used in past years. The design was

created in Solidworks and was completed during C term, allowing for some time to communicate with VR3 to receive a quote for the cost of a tube set and welding of the frame.

Beginning this year, the car must use a Briggs & Stratton 10 hp OHV Intek, Model 19 engine, a change from the engine used last year. This change also influenced the need for a new frame design that could adequately hold this required engine. The car should be designed to handle well and be able to maneuver easily. It should also be designed so that it is capable of withstanding the stresses that the events will put on the car. This vehicle will be utilized in SAE Baja competitions in the near future and provides students as well as SAE WPI chapter members with an opportunity to develop and practice important engineering principles outside of the classroom through a hands on application.

SAE Overview

SAE International, initially established as the Society of Automotive Engineers, is a U.S.-based, globally active professional association of more than 128,000 engineers and related technical experts in the aerospace, automotive, and commercial-vehicle industries. SAE International's charitable arm is the SAE Foundation, which supports many programs, including A World In Motion® and the Collegiate Design Series [1]. The Collegiate Design Series is in charge of creating a series of competitions for students with the sole purpose of going beyond theory by designing, building, and testing the performance of a real vehicle. This highlights WPI's motto "Lehr und Kunst" which is German for "Theory and Practice". That is why SAE International and its Collegiate Design Series program is so welcomed at this Institution. One of the Collegiate Design Series' very well-known competitions is the Baja SAE.

Baja SAE is an intercollegiate engineering design competition open to both undergraduate

and graduate students. Each team has to design, engineer, build, test, promote, and compete with a vehicle within the limits of the rules and follow good engineering practices [2]. The overall objective of the competition is to simulate real-world engineering design projects and their related challenges. Baja SAE consists of seven competitions: Three competitions are held in North America under the sponsorship of SAE International.

What is a Baja vehicle?

The Baja vehicle is a single-seat, all-terrain, sporting vehicle that can withstand the harshest elements of rough terrain. The vehicle should aim for top performance in terms of speed, handling, ride, and ruggedness in off-road conditions. Performance is measured by success in the dynamic events which are described in the Baja SAE Rules, including event-site weather and specific course conditions.

Background Research

Vehicle Subsystems

Before engaging into modifying any of the components of the vehicle, the team needed to become familiar with all the parts that compose a vehicle. A diagram was created which shows all the subsystems of the Baja vehicle. These systems include the steering, suspension, brakes, engine, drivetrain, and frame. See Appendix A.

Frame

When designing the frame, the SAE Rules require that minimum diameter and thickness tubes are used for both the primary and secondary members of the frame. Both types of tube must be at least one inch in diameter. Primary members are the major structural members and had to be at least 3mm. They are denoted by the red members in Figure 1. The secondary members must be at least 0.089mm and are denoted in Figure 1 by all colors but red. All the tubes must also be made of steel with at least 18% carbon. Previous MQP groups have used AISI 4130 Steel, also known as chromoly steel. It has a carbon content anywhere from 28%-33%. It also has a high Young's Modulus at 460.0 MN/m^2 , so the material would be very strong and could take a lot of force before it begins to deform.

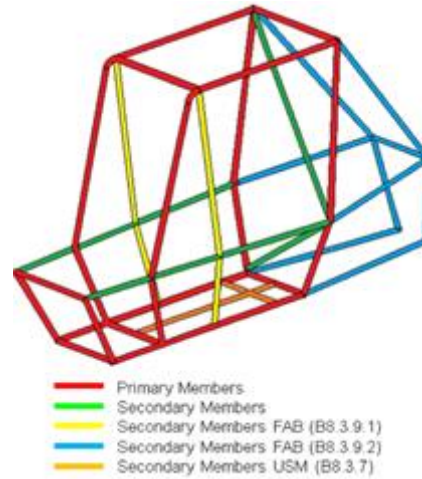

Figure 1 Primary and Secondary Member Classification

Suspension

Suspension is defined as a system of tires, tire air, springs, shock absorbers, and linkages that connects a vehicle to its wheels and allows relative motion between the two [3]. The suspension system of a vehicle provides shock absorption. It dampens and absorbs the vertical forces that a vehicle might run into [4]. It also maintains contact between the tire and the driving surface [5]. If a vehicle does not have a suspension system, then an upward force could lift the tire off of the ground if it were to come in contact with an obstacle in the road. The suspension system would allow tires to move up or down with a road surface while maintaining the frame height [5]. There are generally different suspension types used for the front and rear of a vehicle. Since the front and rear are two independent systems —two wheels connected by the front axle and two wheels connected by the rear axle— it is common to have a different type of suspension on the front and rear. This is greatly determined by whether a rigid axle binds the wheels (dependent system) or if the wheels are permitted to move independently (independent system) [6]. Dependent front suspensions are more common on trucks and have not been used on mainstream cars for years [6]. The MacPherson strut, developed by Earle S. MacPherson of General Motors in 1947, is the most widely used independent front suspension system, especially in cars of European origin

[6]. The MacPherson strut combines a shock absorber and a coil spring into a single unit. This provides a more compact and lighter suspension system. Another common type of independent system is the double-wishbone, also known as double A-arm, suspension. Double-wishbone suspensions allow for more control over the camber angle of the wheel, which describes the degree to which the wheels tilt in and out. They also help minimize roll or sway and provide for a more consistent steering feel. Because of these characteristics, the double-wishbone suspension is common on the front wheels of larger cars.

Shock Absorber

The two main types of force dampening used in suspension systems are 1) the use of springs, and 2) the use of oil and nitrogen. Examples of springs used in force dampening include coil-over springs, leaf springs, and torsion bars combined with a piston to provide fluid friction dampening. Examples of oil and nitrogen used in force dampening includes various valves contained in fluid shock [4]. Both of these force dampening types use the concepts of compression and decompression. A coil over shock is shown in Figure 2 and an air shock is shown in



Figure 2 Coil Over Shock Absorber



Figure 3 Air Shock Absorber

Wheel Alignment

When designing a suspension, it is very important to consider certain parameters that will greatly affect the wheel path of a vehicle. Those are: camber, caster, toe, and steering axis inclination (SAI). A correct alignment of these parameters will make the tires roll without scuffing, slipping, or dragging under all operating conditions.

Camber

Camber is defined as the inward or outward tilt of the wheel at the top relative to the vertical at the centerline of the wheel in the lateral plane. If the top of the tire is leaning inward toward the center of the car, the wheel has a negative camber. Inversely, if the top of the tire is leaning outward, then the wheel has a positive camber. This can be visually conceptualized in Figure 4 [7]. Camber, at a high angle, will wear the inside or outside tread of the tire. In terms of design, camber is changed by moving the control arm in or out without moving the ball joint.

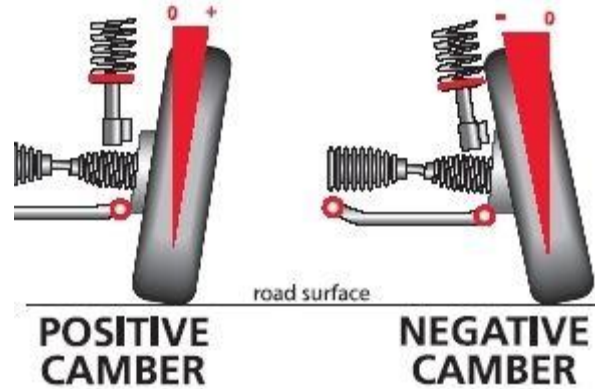

Figure 4 Camber angle

Caster

Caster is the inclination of the steering axis Figure 5. Positive caster is achieved when the steering axis is inclined towards the rear of the vehicle. Inversely, negative camber is when the steering axis is inclined towards the front of the vehicle. Negative caster is rare, only used in heavy duty applications, as the wheel tends to swivel and follow the imperfections of the road. Positive caster is common as it provides greater road feel and helps steering wheel returnability and stability [8]. In terms of design, caster is adjusted by moving the control arm so that the ball joint moves toward the front or rear of the vehicle.

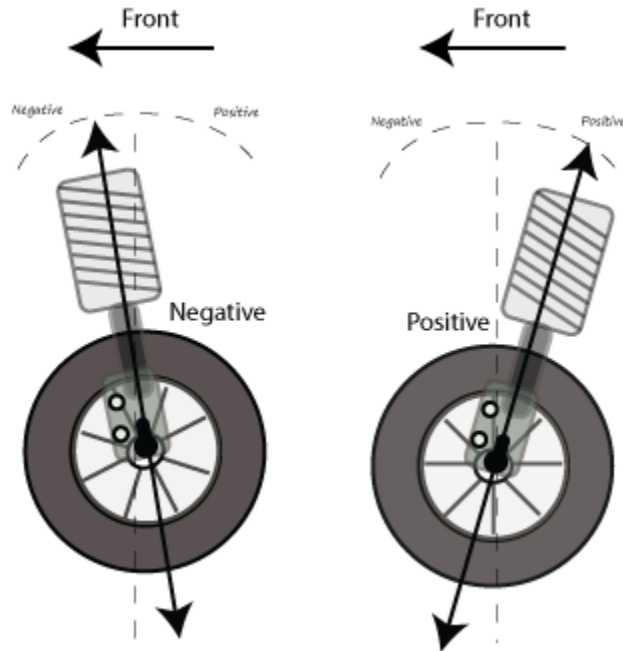

Figure 5 Caster

Toe

Toe is determined by the difference in the distance between the front and rear of the left and right-hand wheels [8]. Toe controls whether the wheels roll in the direction of steering or travel. Toe-out is when the wheels are farther apart at the front than in the rear. Inversely, toe-in is when the wheels are closer at the front than at the rear (see Figure 6). Toe-in can give greater straight-line stability but will reduce the turning response and increase tire wear. Generally, front wheels propel the vehicle, since they tend to push forward due to the engine torque. This push causes the wheels to point inward (toe-in) hence, to compensate this, the wheels are usually set to have a toe-out at the front (approximately 1/16" or -5 degrees) [8]. Additionally, toe-out is a static alignment made to minimize tire scrub and rolling resistance, which develop when a vehicle is cornering. In terms of design, toe is adjusted by lengthening or shortening the tie-rods.

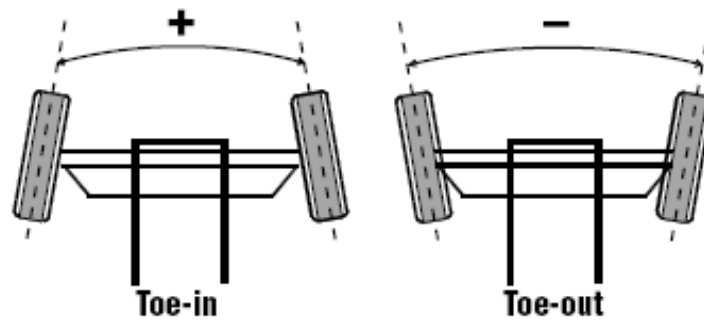

Figure 6 Toe configuration (as viewed from the top)

Steering Axis Inclination (SAI) or King Pin Inclination (KPI)

The steering axis is the axis around which the wheel assembly swivels as it turns to the right or left. It is formed by drawing a line through the upper and lower ball joint pivots. Steering Axis Inclination (SAI) is the angle in degrees between the steering axis and the vertical, as it can be seen in Figure 7. SAI causes both front wheels to gain positive camber as they steer away from center [9]—small amount but not to be neglected, especially for a vehicle making tight high speed turns such as the Baja. This acts with caster to provide self-centering of the front wheels. This gives the car straight line stability. SAI is usually kept below 8° since too much SAI causes a lot of rising of the front axle when steering [9].

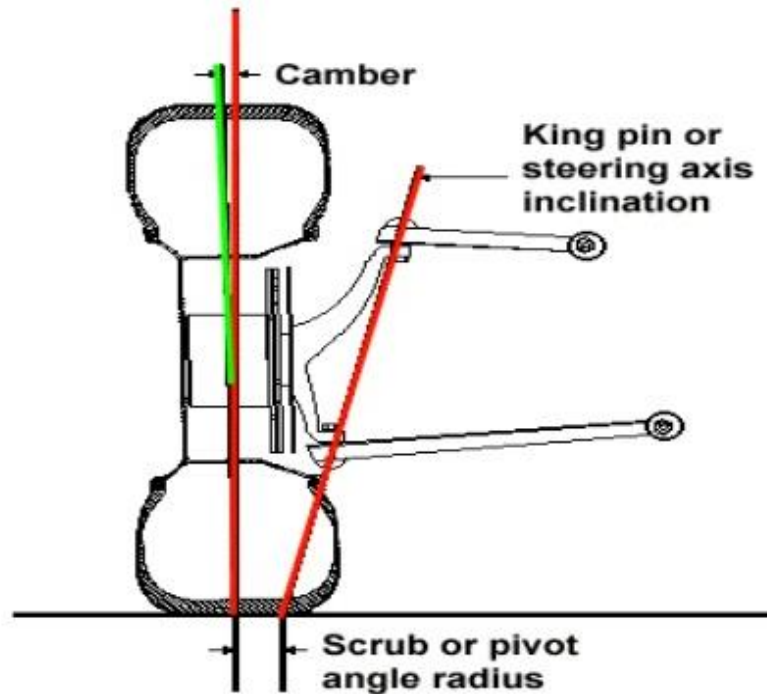

Figure 7 SAI / KPI

Another important parameter, within steering, is the scrub radius (also seen in Figure 7). Scrub or pivot angle radius is the distance at the road surface between the steering axis line and the centerline of the wheel, where the tread contacts the road. If these lines intersect at the road surface, a zero scrub radius would be present. When the intersection is below the surface of the road, this is a positive scrub radius. Conversely, when the lines intersect above the road, negative scrub radius is present. This distance must be exactly the same from side to side or the vehicle will pull strongly []. In terms of design, the scrub radius is changed whenever there is a change in wheel offset. For example, when the wheels are pushed out from the body of the vehicle the scrub radius becomes more positive. Ideally, on the front suspension, a small positive scrub radius gives stability because it causes toe out when braking and toe in when accelerating, in addition to easier steering. A negative scrub radius is suitable for vehicles with high power engine [[Page 16 of 125](http://www.car-</p>
</div>
<div data-bbox=)

engineer.com/suspension-design-definitions-and-effects-on-vehicle-behavior/]. In this case, for the Baja vehicle, a small positive scrub radius is ideal as it is powered by a small engine. The greater the scrub radius (positive or negative), the greater the steering effort and the more road shock and pivot binding that takes place. If the scrub radius is exactly zero, this causes scrubbing action in opposite directions when the wheels are turned, thus tire wear and some instability in corners is the result.

Methods and Procedure

Design Specifications

The following specifications were established with the intention of optimizing the SAE Baja vehicle and ensuring compliance of the Baja SAE competition requirements as regulated in the SAE International 2017 Collegiate Design Series Baja SAE Rules.

Vehicle performance specifications:

- Must be able to withstand all obstructions or a combination of any:
 - Rocks
 - Sand jumps
 - Logs
 - Steep inclines, climb hills of 40 degrees
 - Mud
 - Shallow water, showers
 - Weather: rain, snow, and ice
- Able to fall from a 15 ft jump and not break
- Able to reverse
- Adequate ground clearance and traction
- Contain four or more wheels not in a straight line
- Overall size
 - Less than 108 in. (274 cm) long
 - Less than 64 in. (162 cm) wide
- Limit weight of vehicle without person to approx. 400-450 lbs

- Hold a person of specific size - 95th percentile male / 5th percentile female:

Table 2 Male/Female Driver Parameters

| Parameters | Male | Female |
|-------------------------|------------------|----------------|
| Weight | 102kg/ 225lb | 49kg/ 108lb |
| Standing height | 186.5cm/ 73.4in. | 151cm/ 59.6in. |
| Hip height | 100.0cm/39.4in. | 74cm/29.1in. |
| Erect sitting height | 97.0cm/38.2in. | 79.5cm/31.3in. |
| Sitting shoulder height | 64.5cm/25.4in. | 50.5cm/19.9in. |
| Sitting shoulder width | 50.5cm/19.9in | 37.5cm/14.8in. |
| Hip width | 40.5cm/15.9in. | 31.0cm/12.2in. |
| Shoulder grip length | 71.5cm/28.1in. | 55.5cm/21.9in. |
| Foot length - bare | 28.5cm/11.2in | 22.0cm/8.7in. |
| Foot width - bare | 11.0cm/4.3in. | 8.5cm/3.3in. |

- o 3in. Buffer space for 95th percentile male body
- o 6in. Buffer space for 95th percentile male head/helmet

Design Analysis

Suspension System

Former MQP teams recommended that this MQP team optimize both the front and rear suspension. After reading the former MQP team's recommendations, this MQP decided to completely redesign both the front and rear suspension. Research into suspension systems indicated that it would be beneficial for competition to have a double A-arm for the front suspension and a single semi-trailing A-arm for the rear suspension. An example of a double A-

arm used in the front suspension is shown by RIT's Baja vehicle in Figure 8.

Looking at previous MQP data, it was determined that the vehicle would weigh roughly 600 lbs fully loaded. The team assumed a 40% weight distribution in the front and 60% weight distribution in the rear. This led to approximately 240 lbs and 360 lbs in the front and rear, respectively. [4] Based on the criteria, it was decided that the best option was the coil over shocks.

When discussing the suspension with members of the Formula SAE MQP, the team decided on welding the tabs and suspension with weld cups to include spherical joints. Spherical joints will allow for angular rotation in two directions about the central point. This will be advantageous to withstand obstacles during competition.



Figure 8 RIT's 2016 Vehicle Showing Double A-Arm in the Front Suspension

We are ideally designing the suspension with front control arms with a length of 0.254 m (10 in.). The ideal rear control arms will be a little longer than the front control arms because of the fact that they will be trailing.

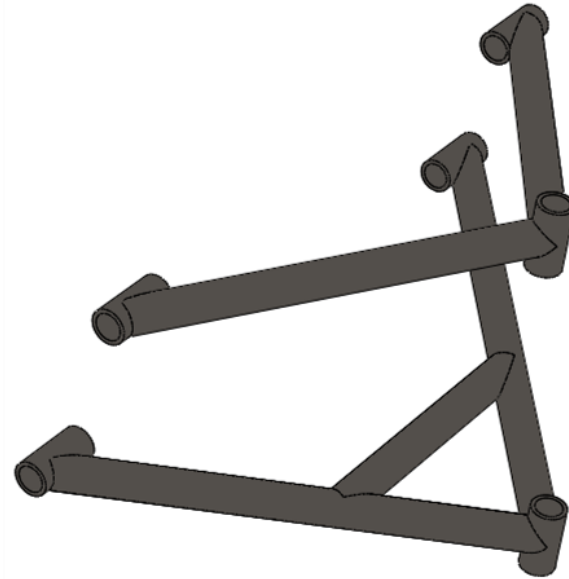

Figure 9 Front suspension design

Front Suspension Design

Rear Suspension Design

The rear suspension was designed by using the recommendations from previous MQP teams and researching what other SAE Baja teams are currently designing for their rear suspension system. The single semi-trailing A-arm proved to be the collective design option for the rear suspension system. In designing the back of the vehicle, the team determined there was 14 inches on each side of the back of the vehicle that the suspension could extend outwards. The team determined the correct geometry for the semi-trailing A-arm in SolidWorks. The team's rear suspension design is shown in Figure 10.

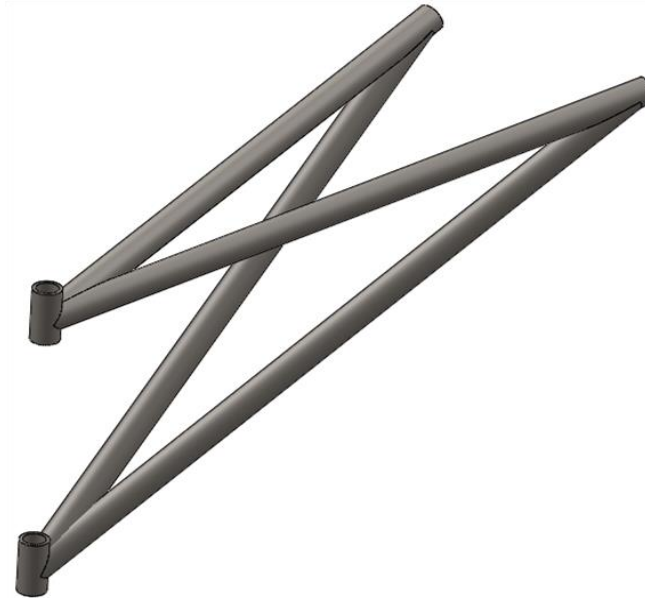

Figure 10 Rear Suspension Design

Steering

In talking with members of the SAE club and observing the previous Baja vehicle, it was decided that the tie rods should be as perpendicular to the side of the vehicle as possible. They should be angled just slightly down and back to give it negative caster, which will make it less difficult for the driver to steer the vehicle.

Transmission

Torque Goal

Hill climb is one of the highly expected obstacles during competition. The Baja vehicle will be expected to go over an incline of significant difficulty. The team assumed the incline to be approximately 40 degrees. Through the inspection of previous courses, the group felt this would be the maximum angle in any hill climb that the team might encounter. In order to successfully go

over the incline, the force on the two wheels will need to be greater than the force of gravity along the incline and the torque needs to be taken into account:

Taking the body and wheels as a whole system: $F_{N1} \neq F_{N2}$

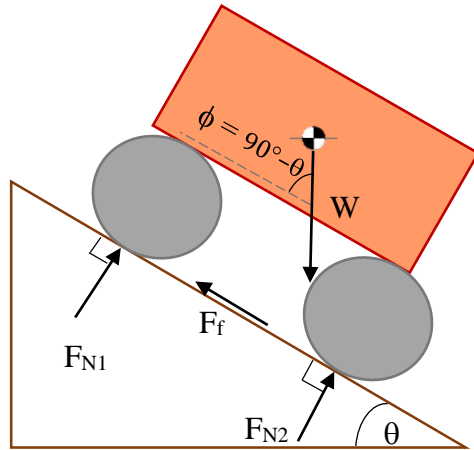

Figure 11 Free Body Diagram of Baja for Hill Climb Event

$$W = 272\text{kg} \left(9.81 \frac{\text{m}}{\text{s}^2} \right) = 2.668 \text{ kN}$$

$$g_x = F_f = W \cdot \sin\theta = 2.668 \text{ kN} \cdot \sin(40) = 1.715 \text{ kN}$$

$$\text{Force per wheel} = \frac{g_x}{2} = \frac{1.715 \text{ kN}}{2} = 0.858 \text{ kN}$$

Assuming a 23 in. diameter wheel:

Torque per wheel:

Equation 1 Torque

$$T = F \times r = F \times \frac{D}{2}$$

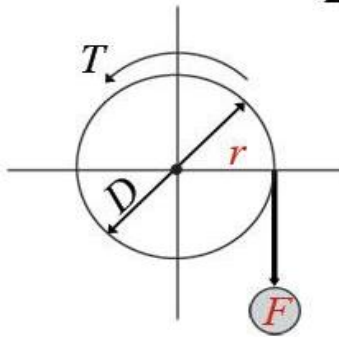

r = distance between the center of rotation
 F = force point

$$T_{\text{wheel}} = F \times r = F \times \frac{D}{2} = 858 \text{ N} \times \frac{23 \text{ in}}{2} \times \frac{0.0254 \text{ m}}{1 \text{ in}} = 250.6 \text{ N}\cdot\text{m}$$

Total torque (T_{total}) on the two wheels = 250.6 N·m

From the result above we know that the minimum torque that needs to be transferred to the final output shaft is 250.6 N·m. Based on the result, and taking into account a factor of safety of 1.4, the team has set 351 N·m as our goal for maximum torque that should be transferred to the final output shaft.

The factor of safety was set to be 1.4 — a value obtained from the Baja SAE forum [6] that calculated 8.5 hp (10 hp at 85% efficiency) using a continuously variable transmission (CVT) also with an 85% efficiency.

Frame

Design Iterations

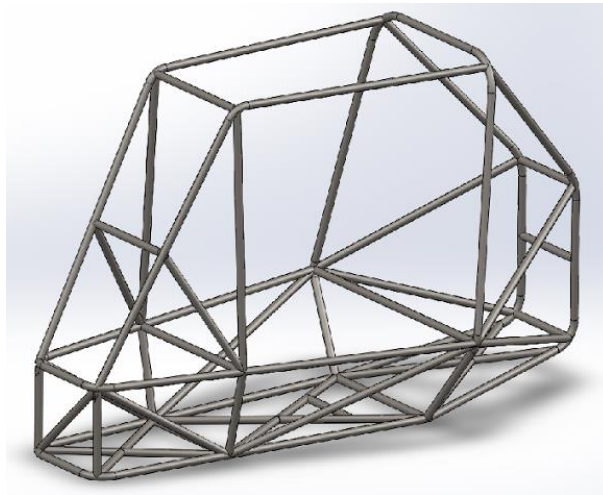

Figure 12 Rounded Square Nose Model of First Frame Design

The first design and model the team produced, shown in Figure 12, had a nose in which the bottom and side members were each a single horizontal piece that wrapped from one side behind the driver's seat around the nose to the other side, just behind the driver's seat. The concept behind

this design was that a single bent tube could be stronger than multiple welds at each corner. Welds could fail, and a bent tube may not break as easily when testing a static force of a total 100kN applied to the front as seen in Figure 13 and Figure 14.

The force of 100kN was obtained with a base in the theoretical maximum velocity of a vehicle. From multiple BSAE forums, the maximum calculated velocity is 40 mph, or 17.9 m/s. The speed is limited by the average weight of the car and driver, as well as the power that the engine can provide. The equations below show the calculation of the force applied in the simulations.

Equation 2 Maximum force

$$F = m * a = m * v * t^{-1} = 272kg * \frac{17.9m}{s} * 0.1s^{-1} = 48,688N \Rightarrow 50kN$$

Equation 3 Factor of safety and applied force

$$FS = 2 \rightarrow 2 * 50kN = 100kN$$

A maximum weight of 272kg is used, as our goal was to keep the frame below 100lbs and assumed a maximum weight of 600lbs, which translates to 272kg. A factor of safety of 2 was used before the analysis in order to make reading the analysis more straightforward. With the total applied force at 100kN, the yield strength of the material can be used as a cutoff point that determines whether the model passes or fails the simulation. Simulations give a graphic of the stresses on the model and a key to describe what the colors represent and the maximum and minimum stresses on the welded frame. The key will provide a red arrow at the yield strength of the material being used, and so if the arrow is visible, the model certainly does not pass the simulation.

In the first design, the maximum stress was 372.7 MN/m², which is under the yield strength of 460.0 MN/m². The maximum displacement, which is not shown, was 1.68mm which is a very low

maximum displacement for this design project. The square nose model performed well in simulations, however the geometry of the front would prove difficult to accommodate the suspension, so the nose was redesigned to incorporate sharp square corners utilizing welds. Before this welded square nose was designed, a rounded bottom nose was modeled and tested, as can be seen in Figure 15.

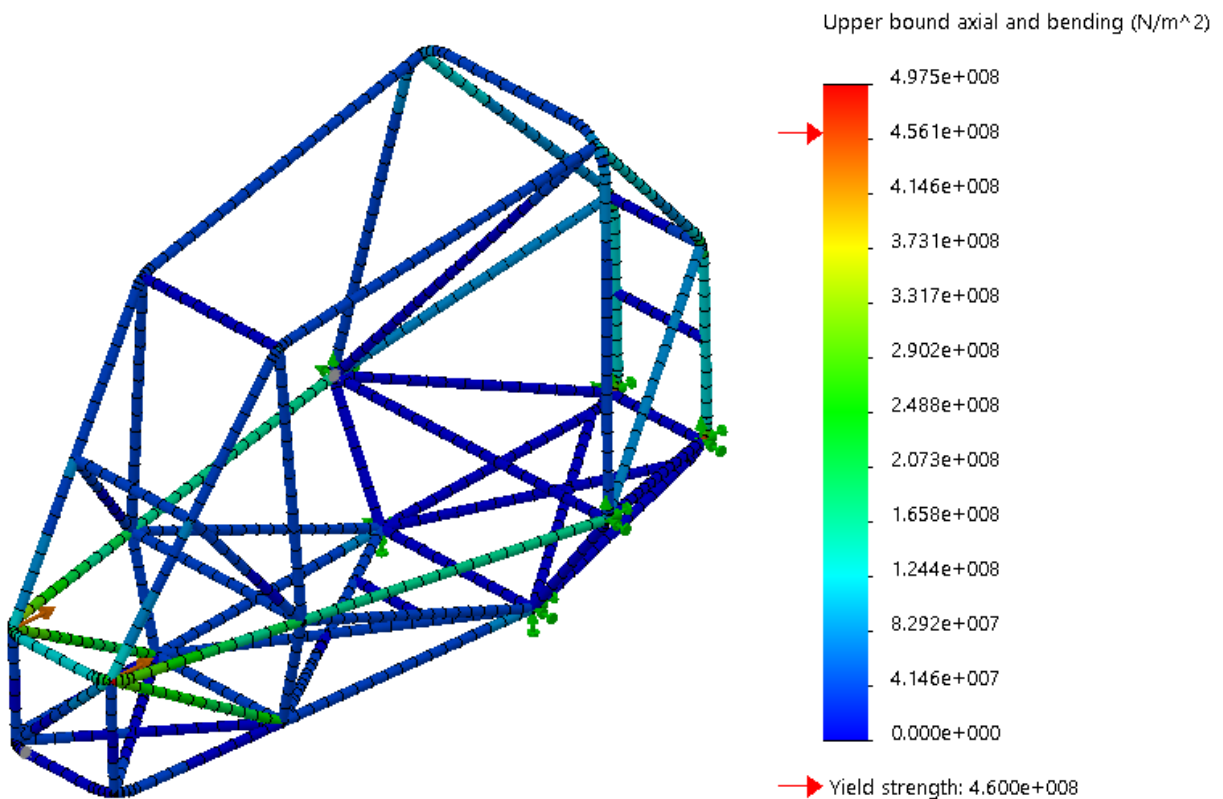

Figure 13 Rounded Square Nose Model Front Impact Four Points Static Force Simulation and Stress Key

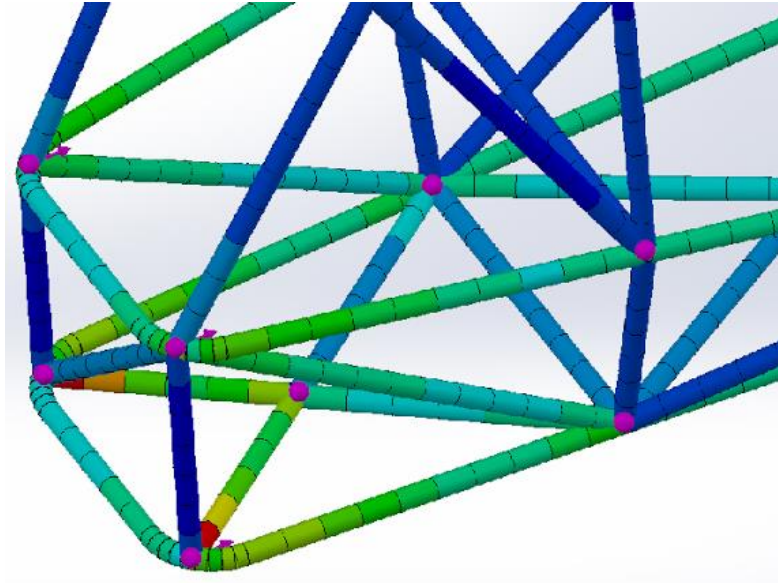

Figure 14 Square Nose Model Close-up of Front Impact Four Points Static Force Simulation

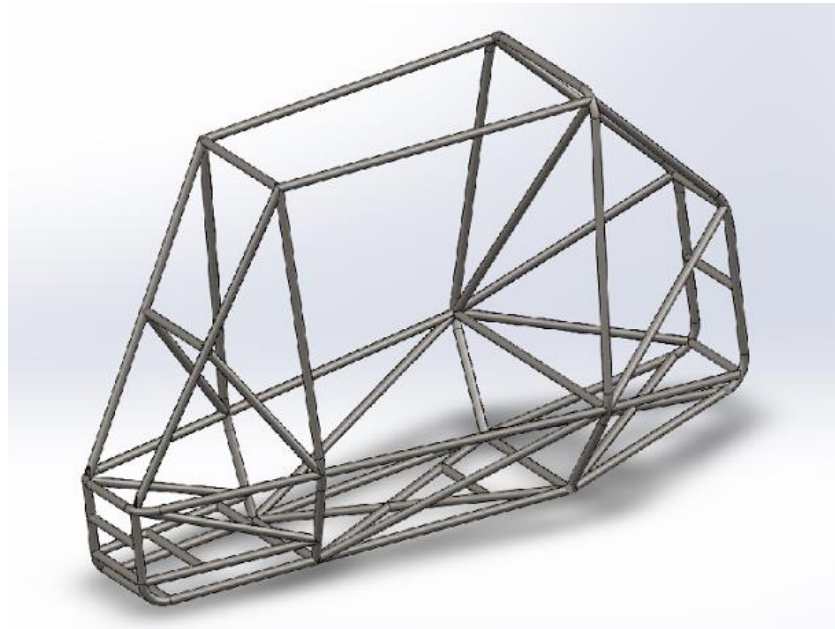

Figure 15 Rounded Bottom Nose Frame Design

The rounded bottom nose frame design was conceived in order to test if the two different directions that the tubes face would improve the overall rigidity of the frame, and particularly the nose. When tested with a static force of 100kN totaled over four points, the frame performed poorer than the square nose design. As seen in Figure 16 and Figure 17, maximum stress was at

572.4MN/m² and located where the force was applied and could not transfer through the bend.

This model was discarded soon after it was tested with simulation because it did not appear to be an improvement on the square nose model design.

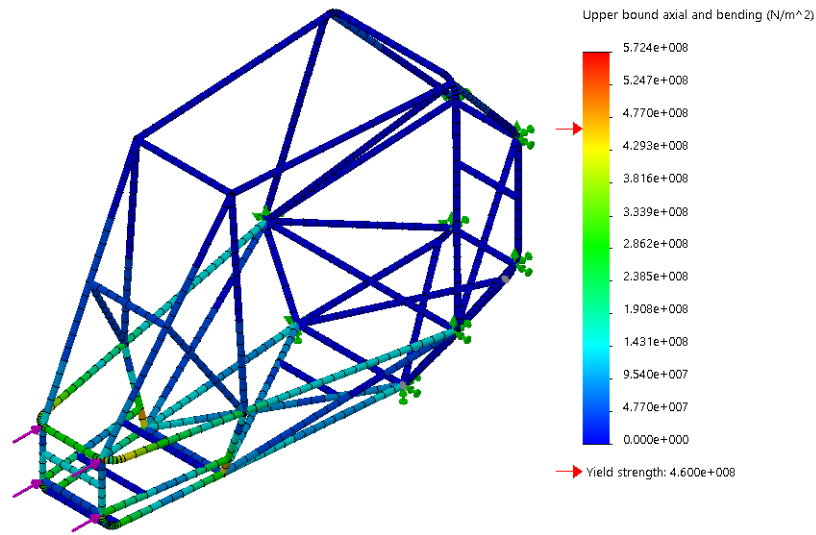

Figure 16 Rounded Bottom Nose Model Front Impact Four Points Static Force Simulation and Stress Key

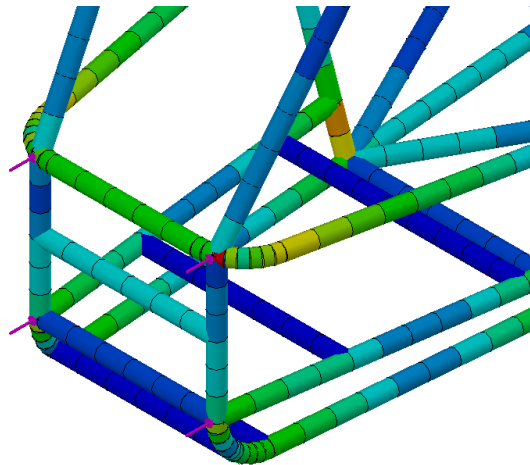

Figure 17 Rounded Bottom Model Close-up of Front Impact Four Points Static Force Simulation

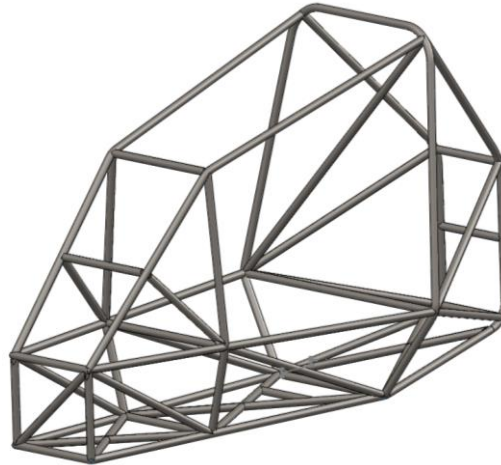

Figure 18 Welded Square Nose Model Frame Design

The welded square nose design in Figure 18 performed even better than the square nose model. As seen in Figure 19, the maximum stress on the frame is 155.4MN/m^2 , and that is located at the rear where the fixed points are. The rest of the frame has a stress of 116.6MN/m^2 or less. Since it did so well, more situations were accounted for in new simulations to test the model. The simulation in Figure 20 shows a total 100kN force being applied over two points at the bottom of the frame. This was simulated because it could be possible that the car runs over something at full speed and hits it with only the bottom of the frame. Figure 21 does not represent the final version of the welded square nose frame, as the frame went through a few more iterations, one of which is shown in Figure 21. This model had the bracing pieces removed from the overhead member as it came down to the top of the nose. It had come to the attention of the team that it may cause visibility issues for the driver. That model was then modified to be longer because when a model of the 95th percentile male was inserted into the frame, it barely fit and there would have been little to no room for foot pedals. The team decided to add an extra section to the front, which serves two purposes. The driver will have plenty of room for his legs, and more space was created in which steering and suspension can attach. With more room in the front that

is not so close to the driver, future years may be able to adopt a different steering mechanism such as full Ackermann steering.

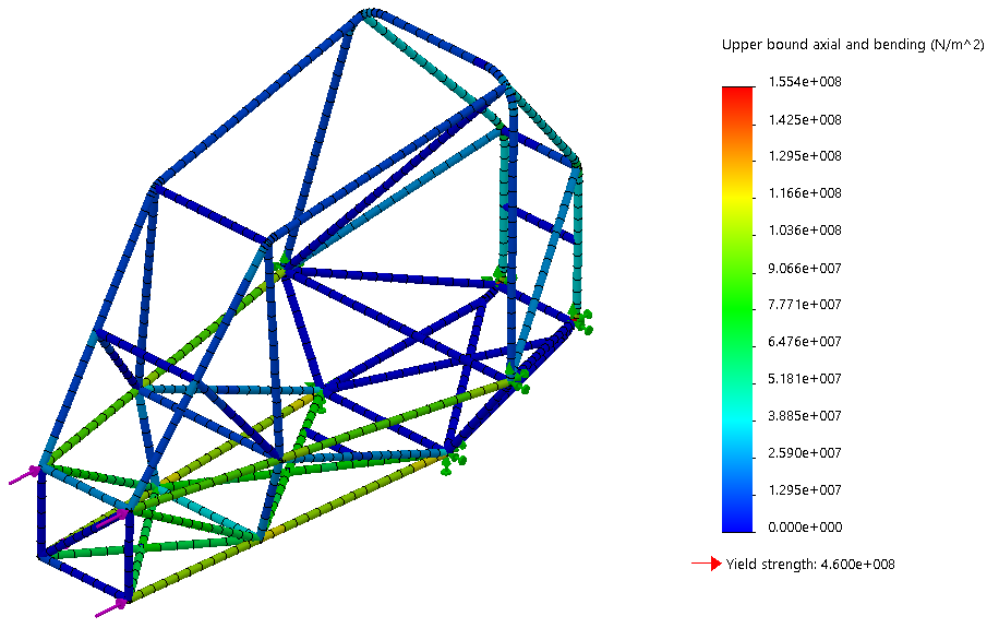

Figure 19 Welded Square Nose Model Front Impact Four Points Static Force Simulation and Stress Key

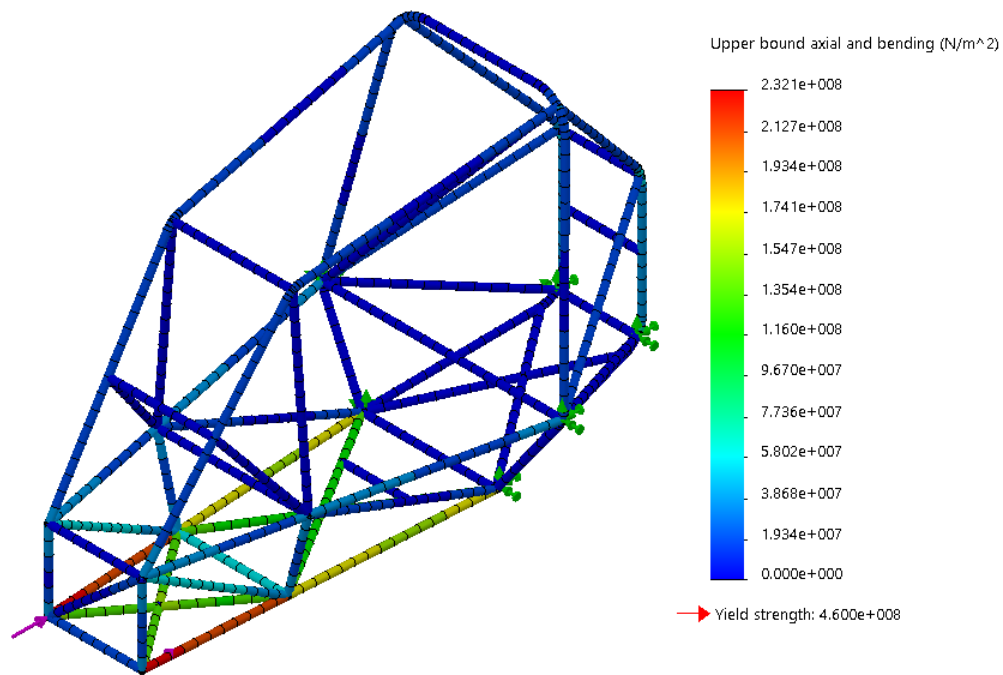

Figure 20 Welded Square Nose Model Front Impact Two Points Static Force Simulation and Stress Key

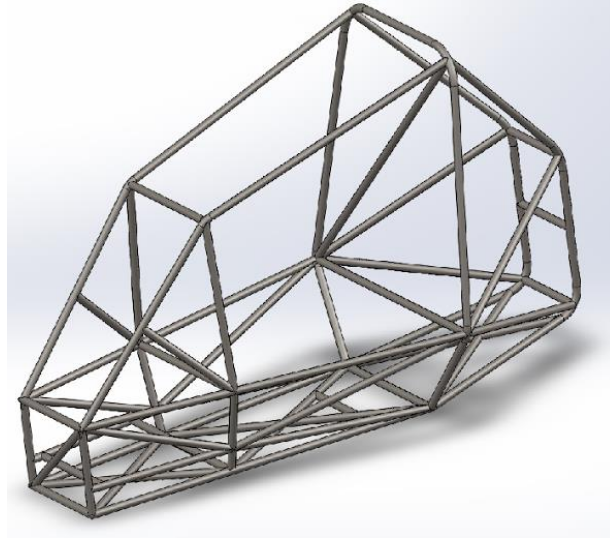

Figure 21 Welded Square Nose Model Modified

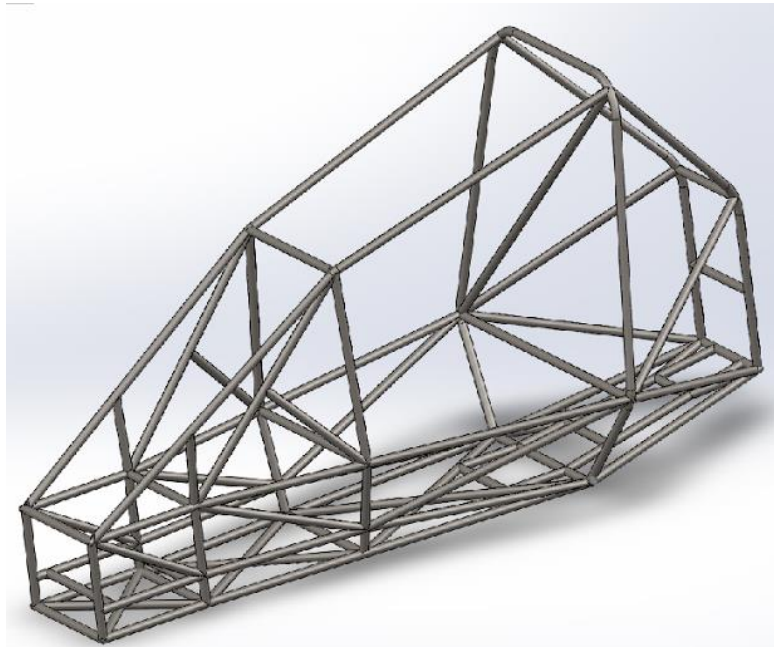

Figure 22 Elongated Welded Square Nose Model

The elongated model added to what already existed in the frame model. This model is shown in Figure 22. It did add weight, and now that the frame is in what is likely its final iteration, it has a weight of 49.3 kg. The model does not fare quite as well in a front collision, but it still stays well under the yield strength at the highest stress in the model. The highest stress is 219.9MN/m^2 in the simulation with four points at which the force is applied, and 322.6MN/m^2 in the simulation

with only two points at which the force is applied.

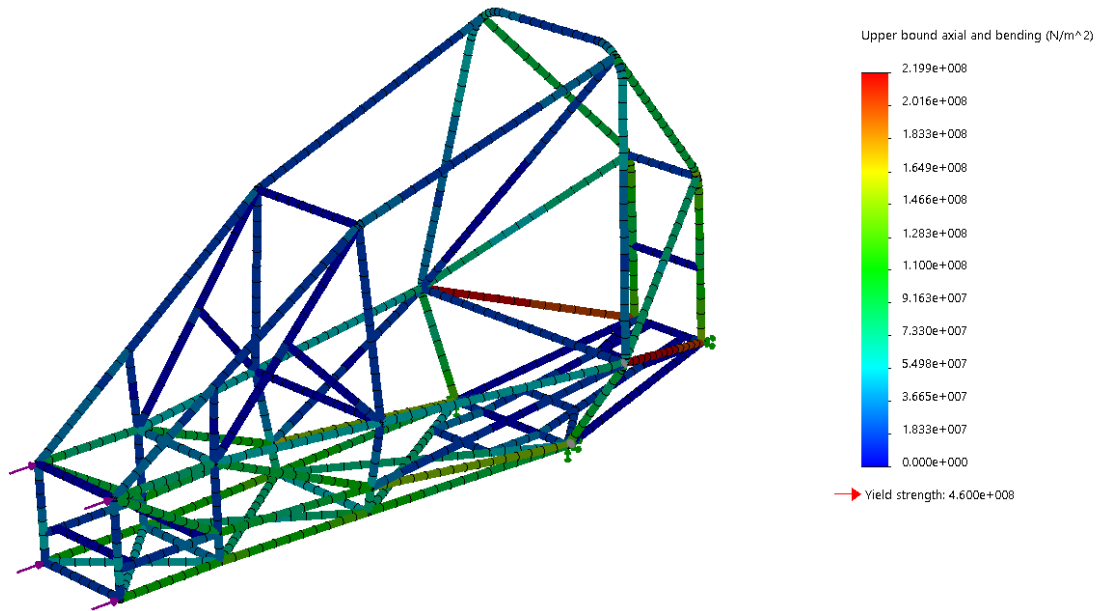

Figure 23 Elongated Welded Square Nose Model Front Impact Four Points Static Force Simulation and Stress Key

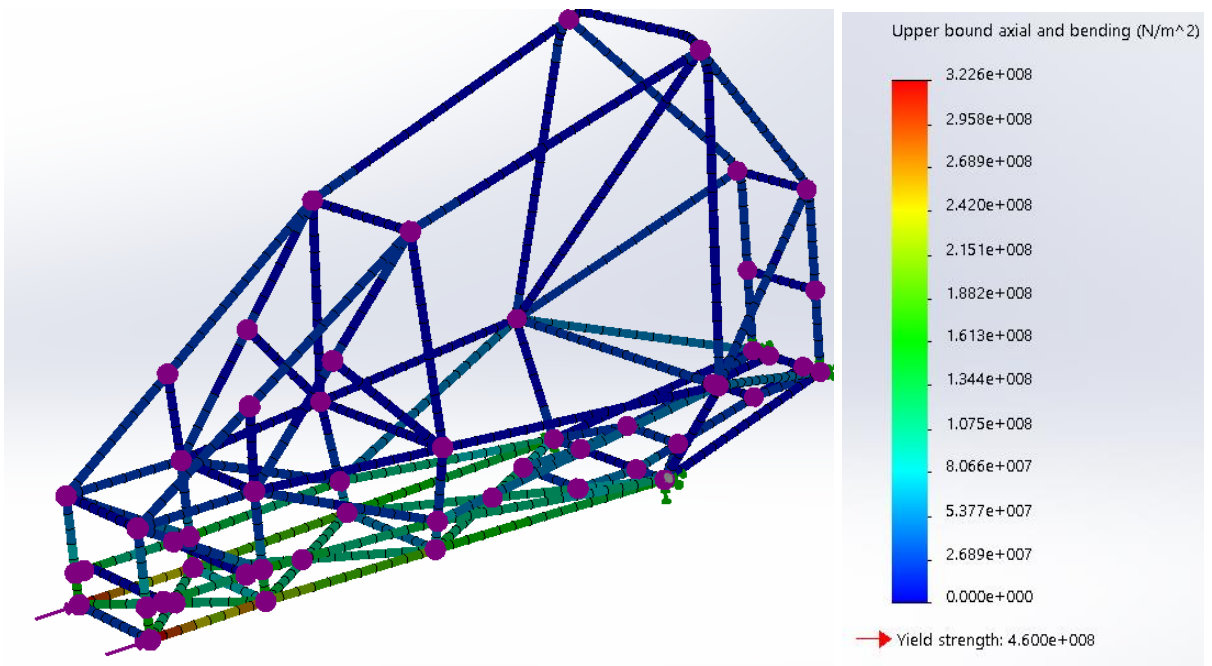

Figure 24 Elongated Welded Square Nose Model Front Impact Two Points Static Force Simulation and Stress Key

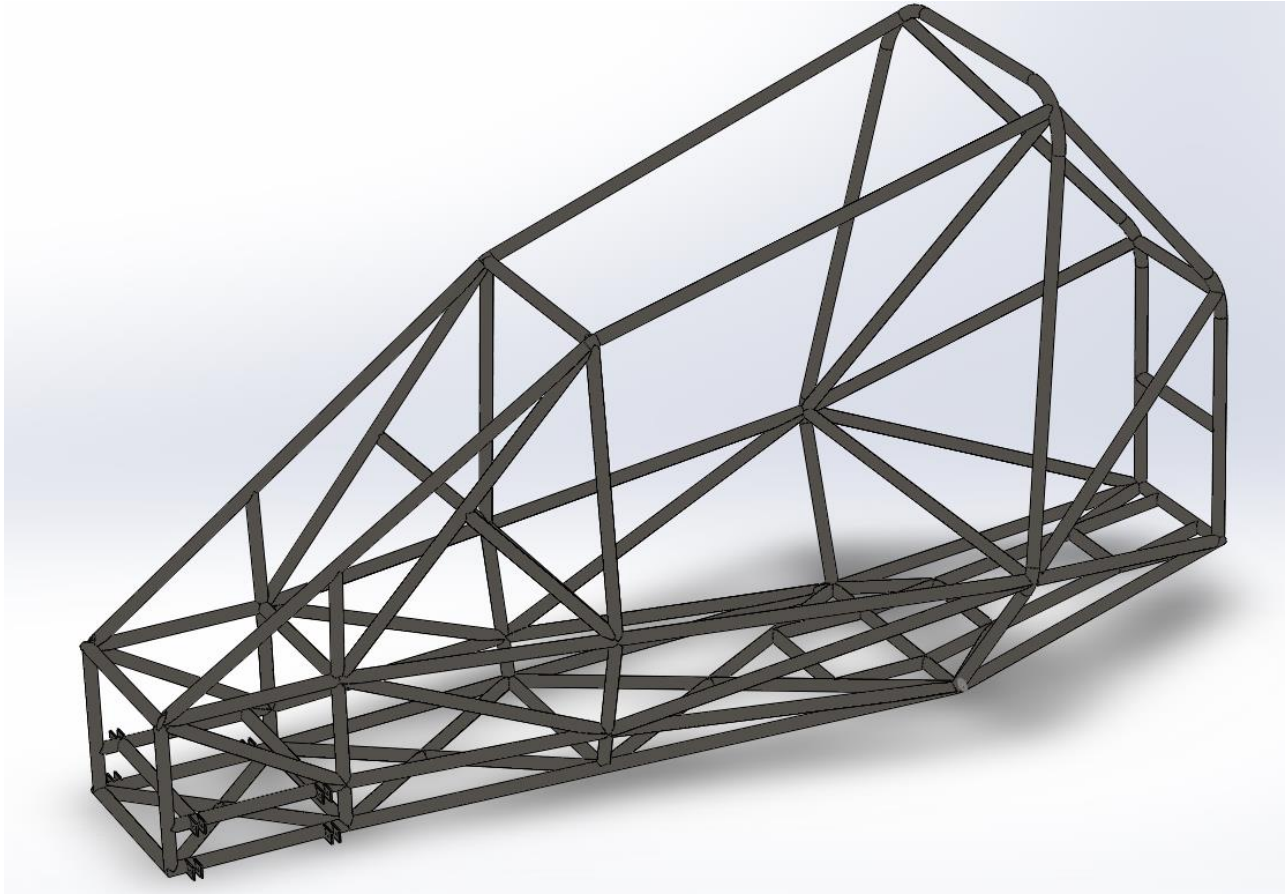

Figure 25 Elongated Frame Design with Front Tabs

Tabs were added to the elongated frame seen in Figure 25, however simulations have not yet been run on it. Other simulations were performed on the elongated frame without tabs. Simulations included front, rear, and side impacts, rollover impact on the overhead member, top impact, and a drop impact. Each simulation included a graphic for both the stresses on the frame as well as the deflection of the frame. These can all be found in Appendix B.

After consideration, the elongated design was determined to be too long and too heavy for the goals of being able to turn and handle well. The design with the basic square nose was determined to be the best with all objectives considered. When examined, the square nose model had to be modified slightly in order to conform to the rules of Baja SAE.

A slightly three dimensional version of Percy was created in SolidWorks to test the size of the

model to ensure that a 95th percentile male would be able to fit within the frame according to the rules. Percy in one iteration of the car is shown in Figure 26.

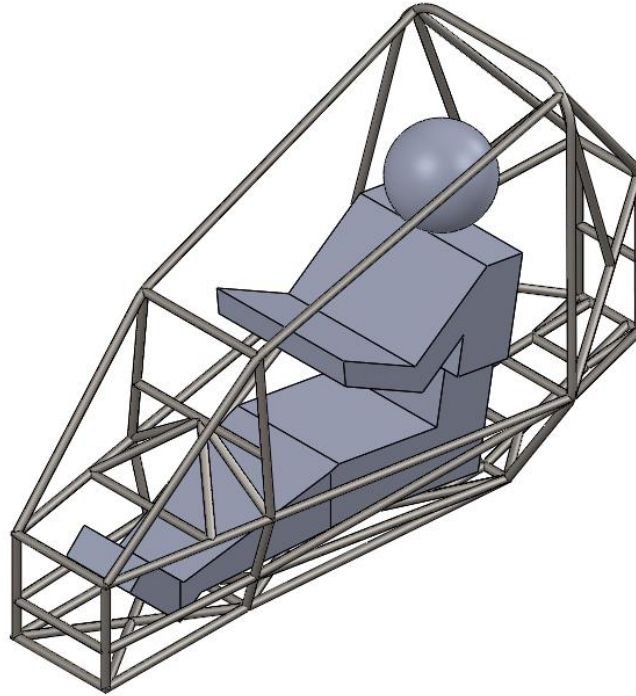

Figure 26 Percy and C10

After a few changes and iterations, the design was finalized. A total of eight simulations were run on the final design, and each one passed, some after a few alterations to the design. The simulation results for the final design can be seen in Appendix C. The stresses and deformations of each beam is shown in the results. Simulations that in their non-deformed state are shown in Figure 27-Figure 32.

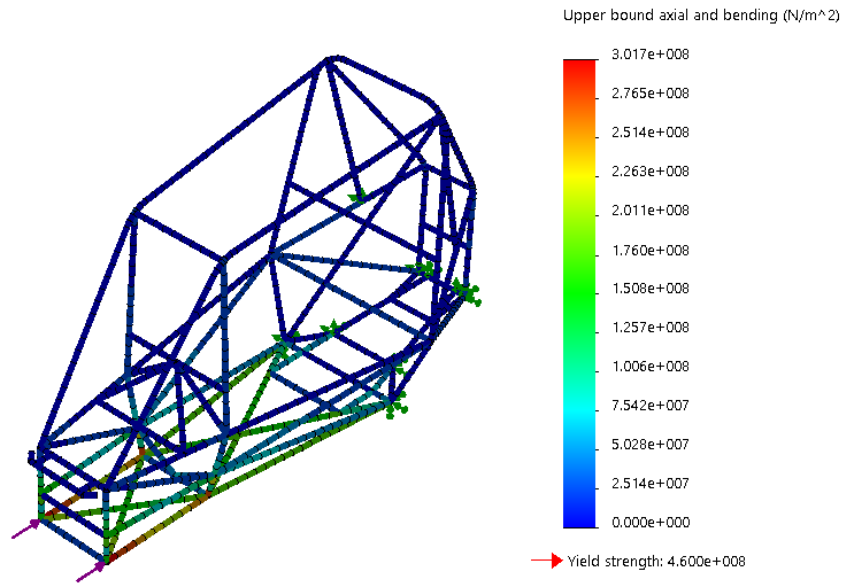

Figure 27 Front Impact Simulation

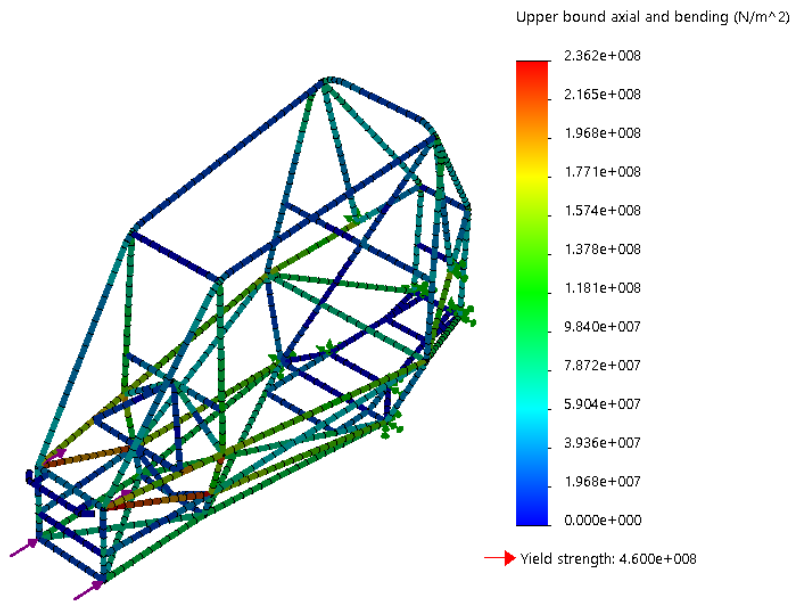

Figure 28 Front Bottom Impact Simulation

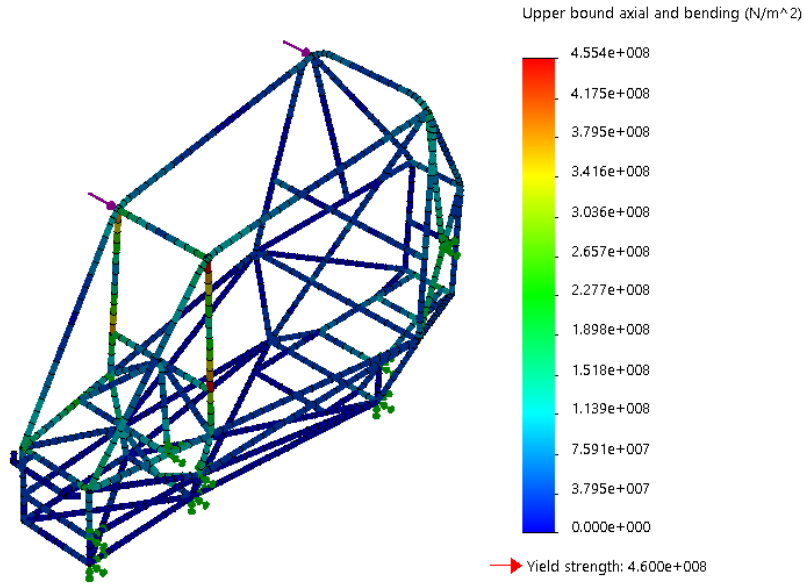

Figure 29 Rollover Simulation

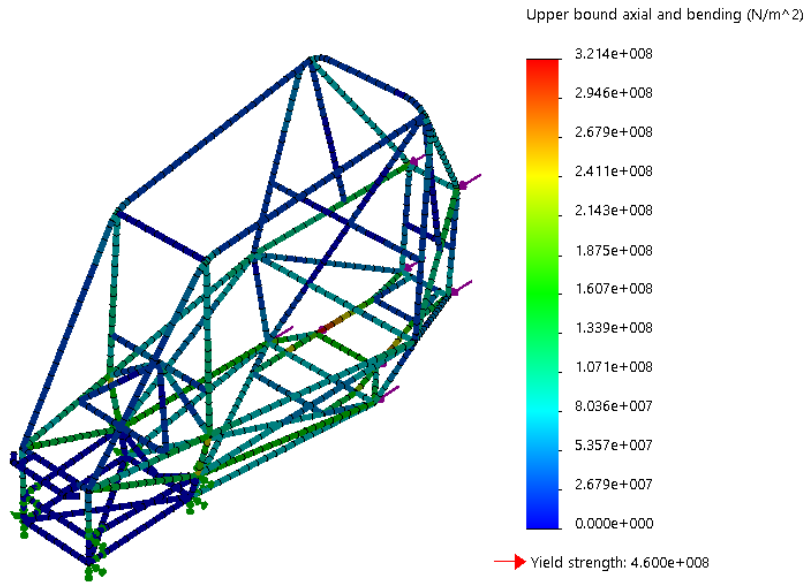

Figure 30 Rear Impact Simulation

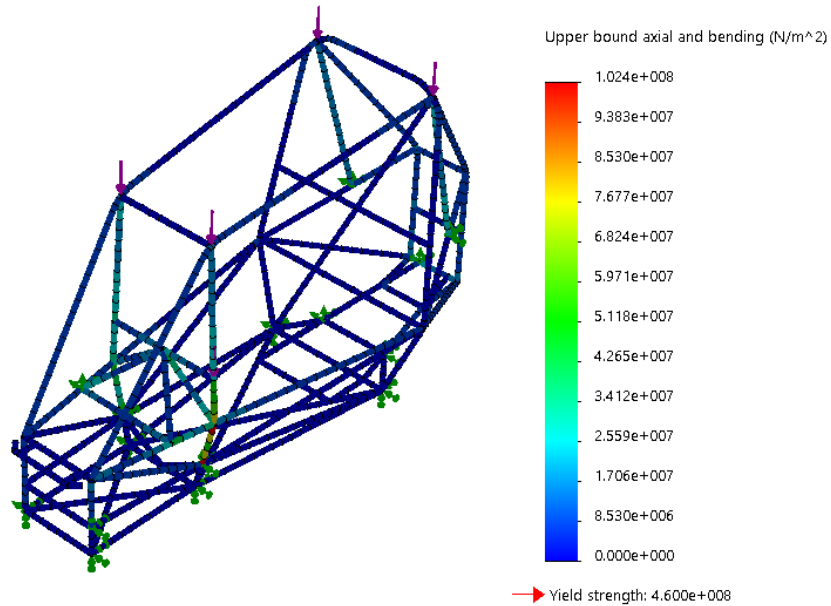

Figure 31 Top Impact simulation

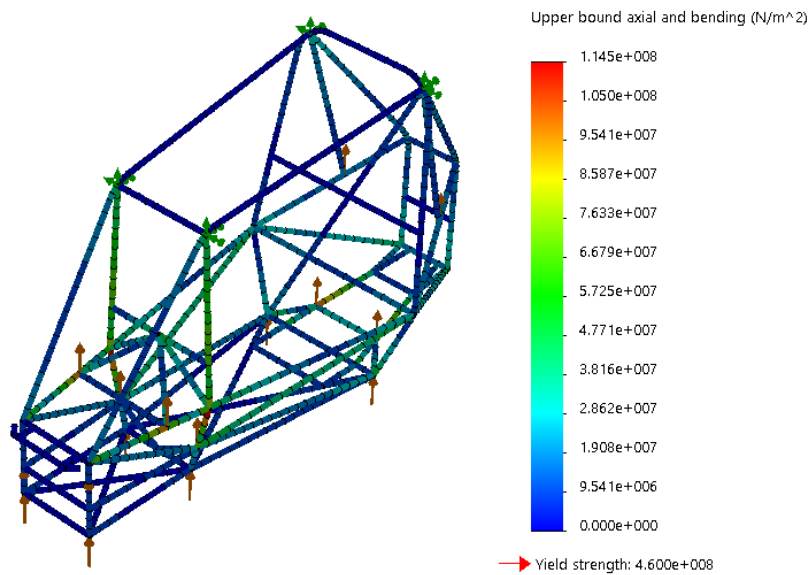

Figure 32 Drop Impact Simulation

The simulations all use a realistic force location and fixed locations in order to better estimate the effect on the frame. Most of the fixed locations were located at the approximate locations that the suspension would be attached. This was done because when a force is being applied to any location, the suspension is what counteracts all the force, and therefore should be the fixed

locations.

Once the design was finalized, all the weldments were saved as their own part files, and an assembly of all of these part files was created in order to receive a quote from VR3. Each tube part had to be numbered and all numbered in the order in which they should be assembled. In addition to the assembly of all parts, VR3 needed the model itself, and a material list which consisted of the size, material, and approximate length of each individual part, as well as the number of bends and radii of bends on each part. In order for the tube set to be created, all the individual part files needed to be provided so that the machines could use the files to CNC cut each part precisely.

The tube set manufacturing and welding of the tube set is occurring over the summer so that the next MQP will have the frame to start. Next year's MQP was consulted before the design was finalized and approved for manufacture to ensure that it agreed with their basic plans for the car and would work well with the type of design they have in mind.

Tabs

Multiple tab designs were created and used in simulations to determine the best mounting configuration for the suspension A-arms. Ideas were generated using a combination of past WPI Baja vehicles and from the Northeastern Baja team. An example of the Northeastern Baja team's tabs are shown in **Error! Reference source not found.** This MQP created SolidWorks models of possible tab designs that ended up having some weaknesses in design. Examples of a few of the team's unsuccessful attempts are shown in **Error! Reference source not found.** In **Error! Reference source not found.** the top left and bottom left tab designs are a single side of the tab and would have another single side connected with a piece of metal going across. The top right

tab in Figure 28 shows a tab that would be created with square tubing. The bottom right tab in **Error! Reference source not found.** shows the team's first iteration of what will become the final tab design. **Error! Reference source not found.** shows the teams attempt at a Northeastern style tab. After the MQP team created a sound SolidWorks model, there was an advancement in the tab design when the team created a model that can be easily altered to tailor the angle the team wanted the tab to be at. This tab design can be altered by changing one angle in the SolidWorks model. Examples of a few iterations of this SolidWorks tab model can be shown in **Error! Reference source not found.**. These pictures show the angle that was altered in the SolidWorks model. The top model is the isometric view of the tab. The thick blue line is the plane where the angle from the plane to the horizontal can change so the team can alter the tab based on the location of the tab on the chassis.



Figure 33 Northeastern Baja tabs

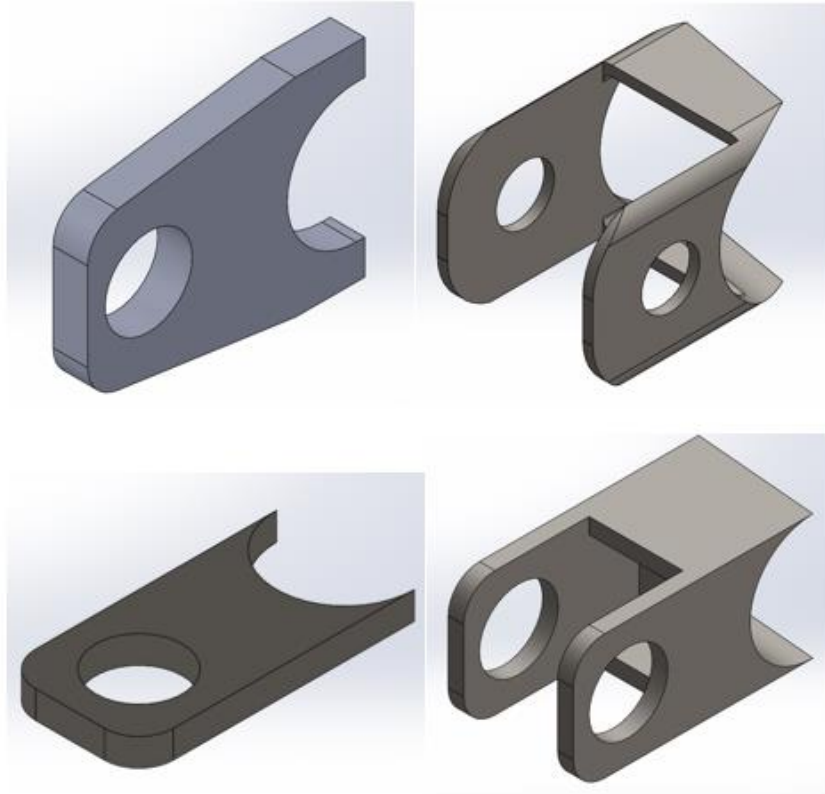

Figure 34 Initial tab models

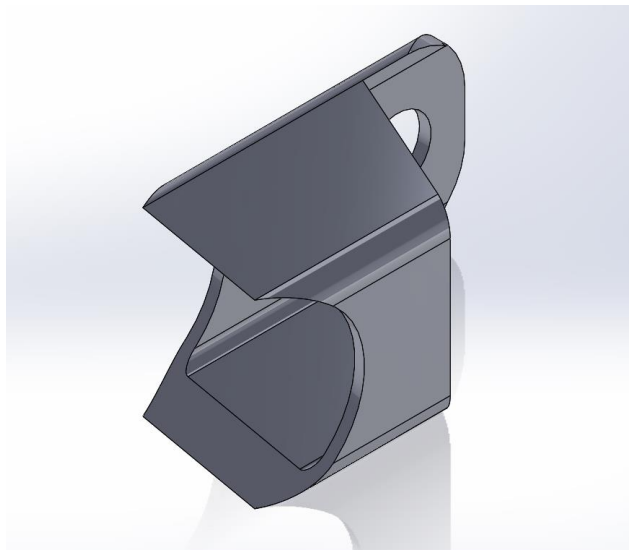

Figure 35 MQP's Northeastern style tab

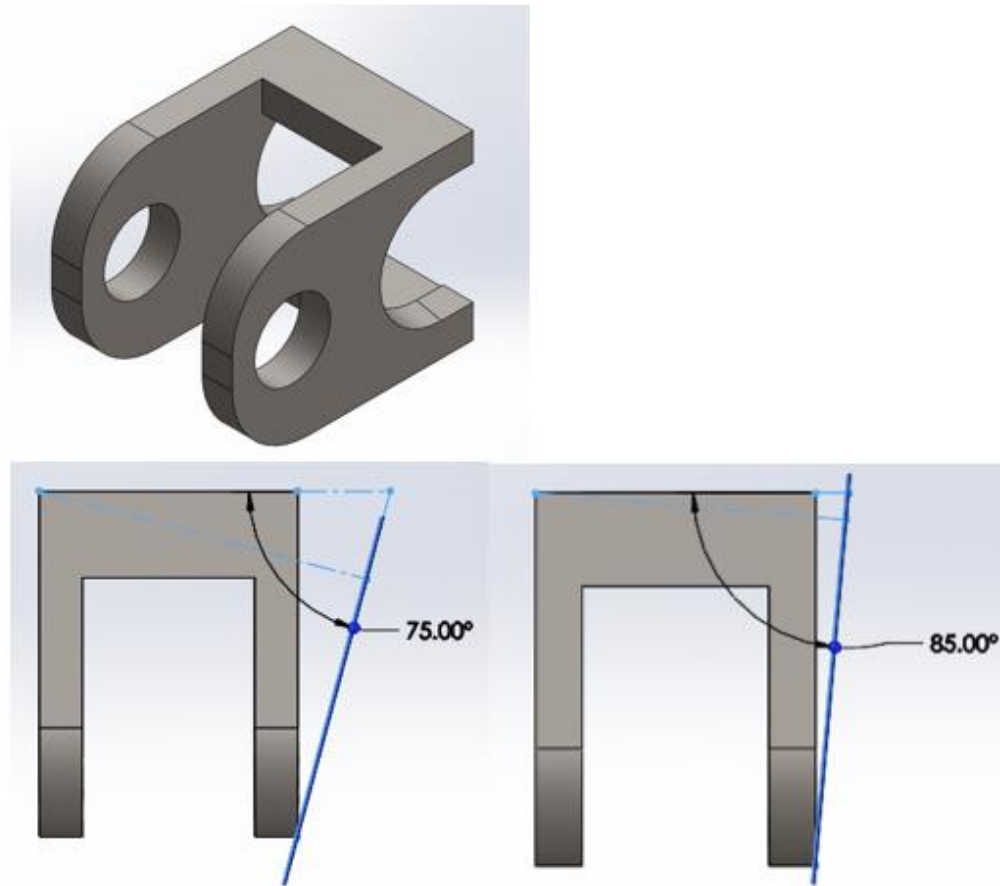

Figure 36 Variable tab model

Conclusion

Throughout the course of this MQP, the team researched, modeled, and simulated various potential designs for a frame that is intended to be used in future years. This frame was designed with the goal of being ready to use in the Baja SAE competition. The team started with a concept which had two parallel members that wrapped around to form the nose and sides. The first concept was able to withstand the forces applied to it in simulation without breaking. Another design was explored that utilized two members that composed the bottom of the frame and curved up at the nose to intersect the top member. That design did not perform as well as the first concept during a frontal impact test. A fully square welded nose was modeled and proved to be

the strongest design. It was then expanded upon to elongate the frame.

The suspensions were designed around the chassis. The front suspension remained as a double A-arm, for a more controlled motion of the wheel throughout suspension travel. It was designed to have a negative camber of -6 degrees to improve control when cornering. Their end points, particularly the kingpin axis, are offset slightly which allows for the Ackermann steering characteristic.

Overall, the chassis fully complies with the 2017 SAE Baja competition rules and is ready to be manufactured. A quote from VR3 Engineering was received for a tube set and welding. This company will be in charge of the manufacturing of the chassis.

Future Work and Suggestions

Continuous work upon our results can be conducted by upcoming teams, including but not limited to:

- Optimize and manufacture suspension
- Attach the tabs and suspensions onto the chassis
- Design the drivetrain and steering system
- Analyze ergonomics and safety features of the overall vehicle
- Participate in the annual SAE Baja competition

In terms of the front suspension design, the team recommends taking advantage of all software available on campus, like Adams Car. Such software allows for input of desired wheel travel parameters and develops a simulation of the suspension system. This could provide higher accuracy of the wheel path during motion, allowing for re-iterations of designs until achieving intended, ideal wheel trajectory. Due to time constraints and inexperience with the software, this team was unable to make use of this software.

Appendices

Appendix A: Baja SAE Vehicle with Subsystems



Appendix B: Elongated Design Simulations

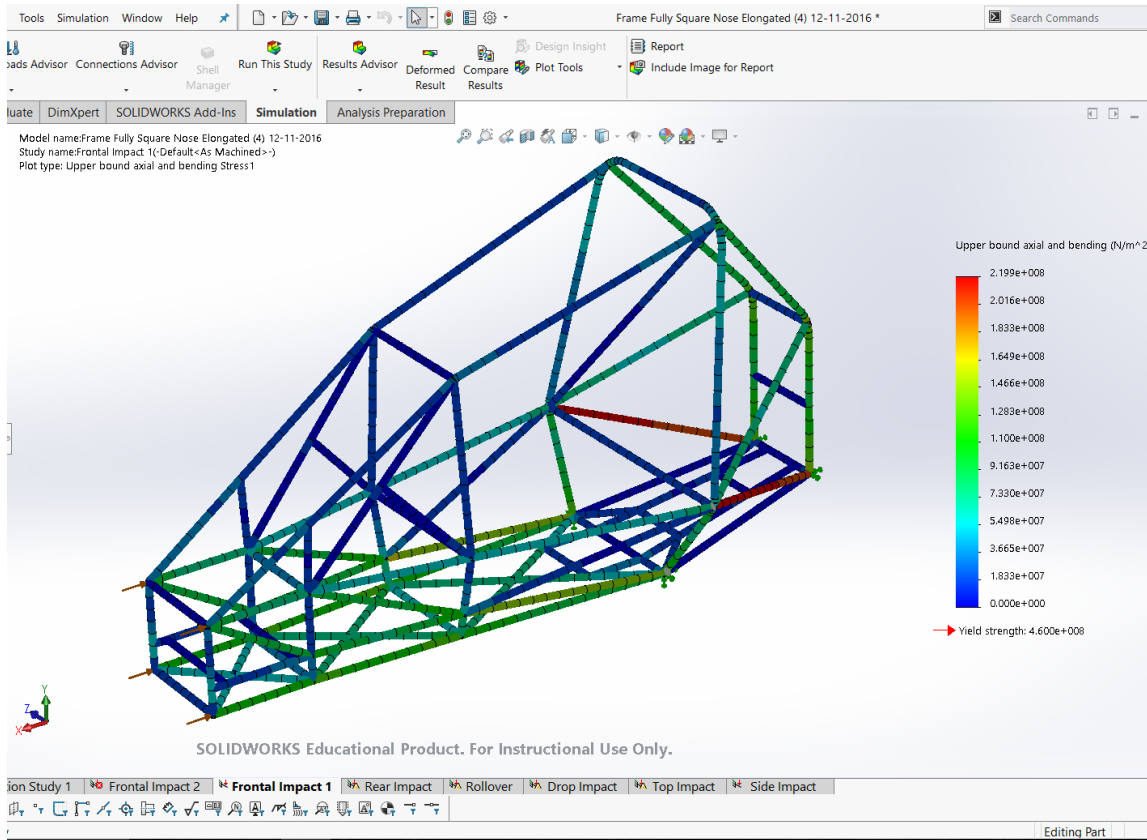

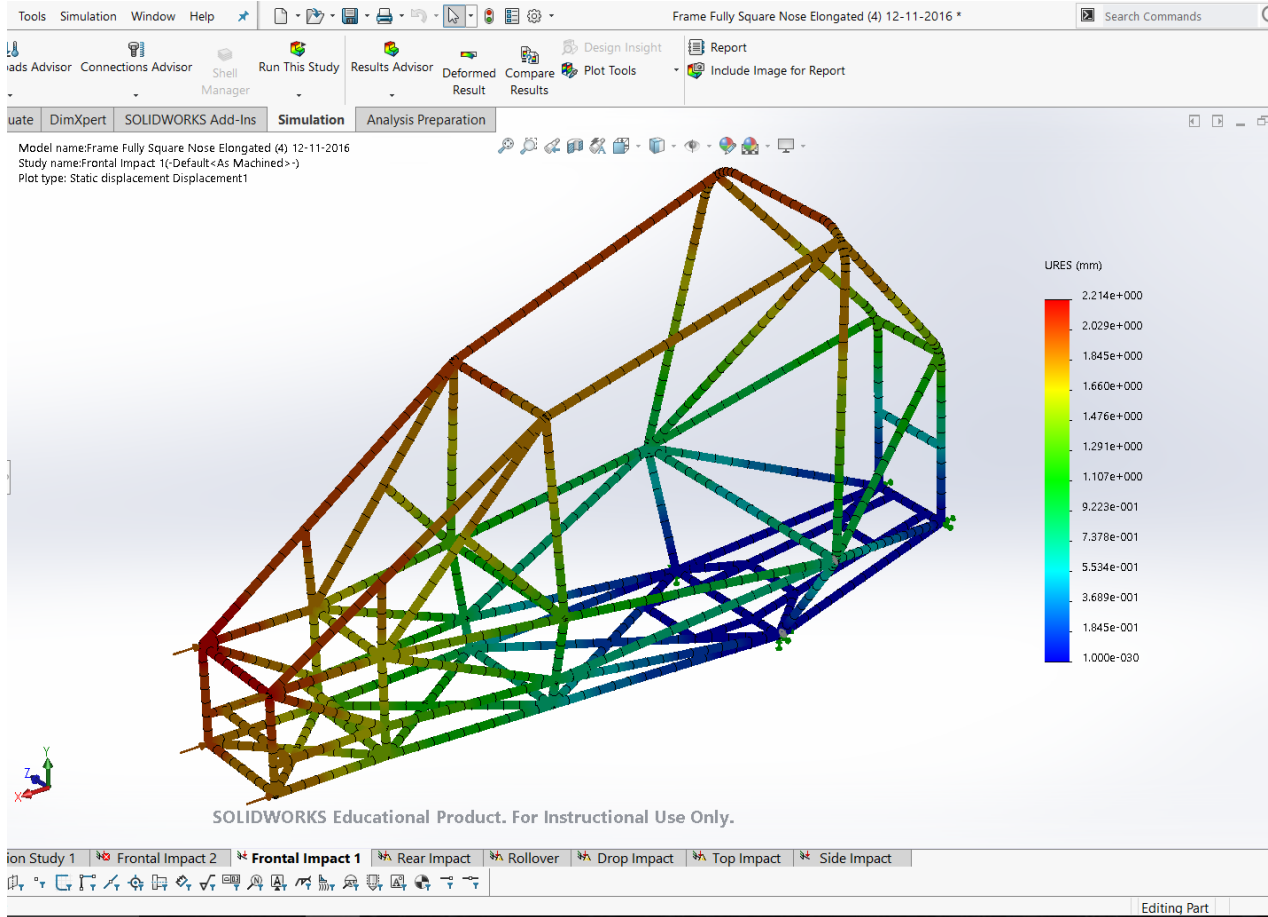

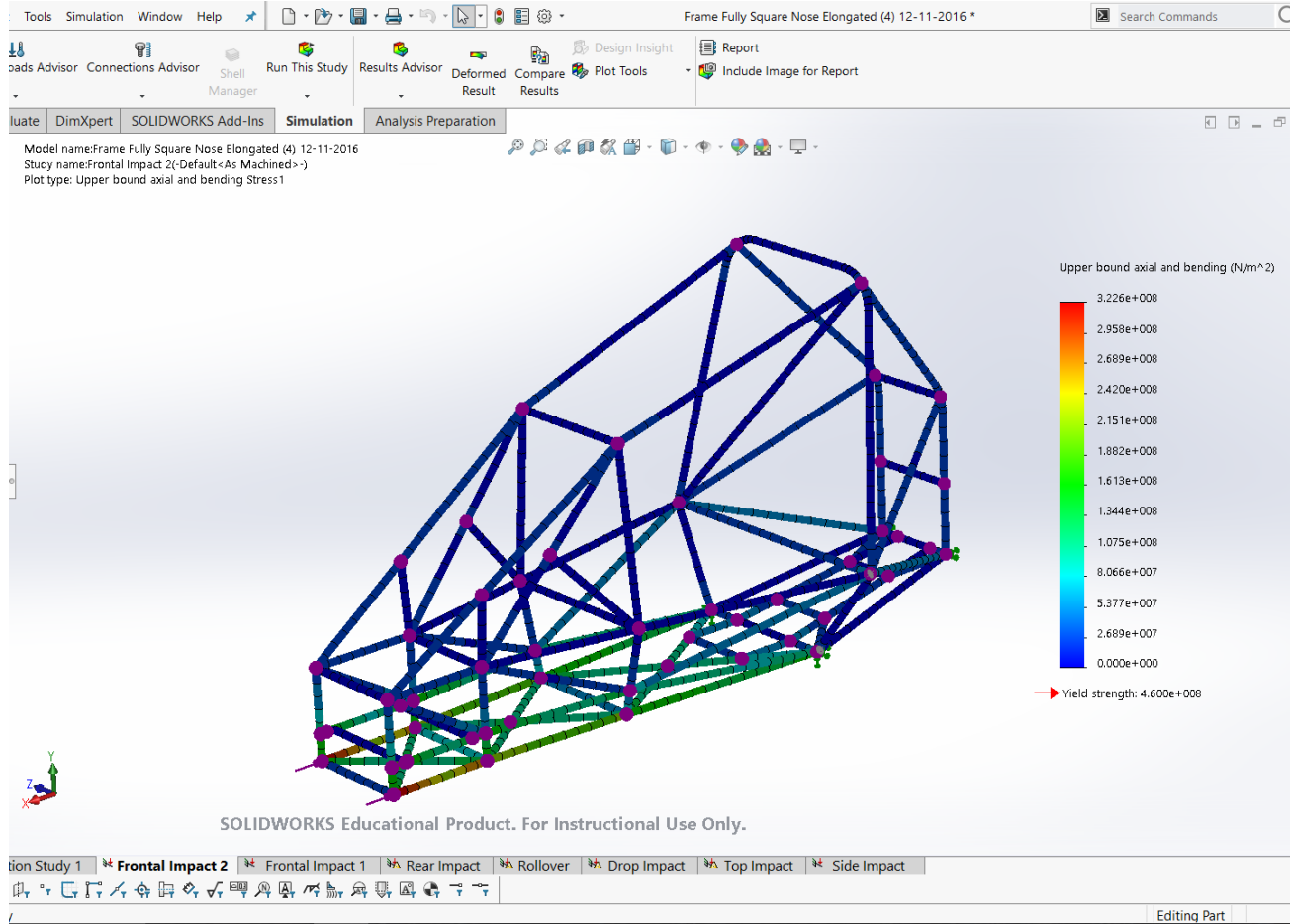

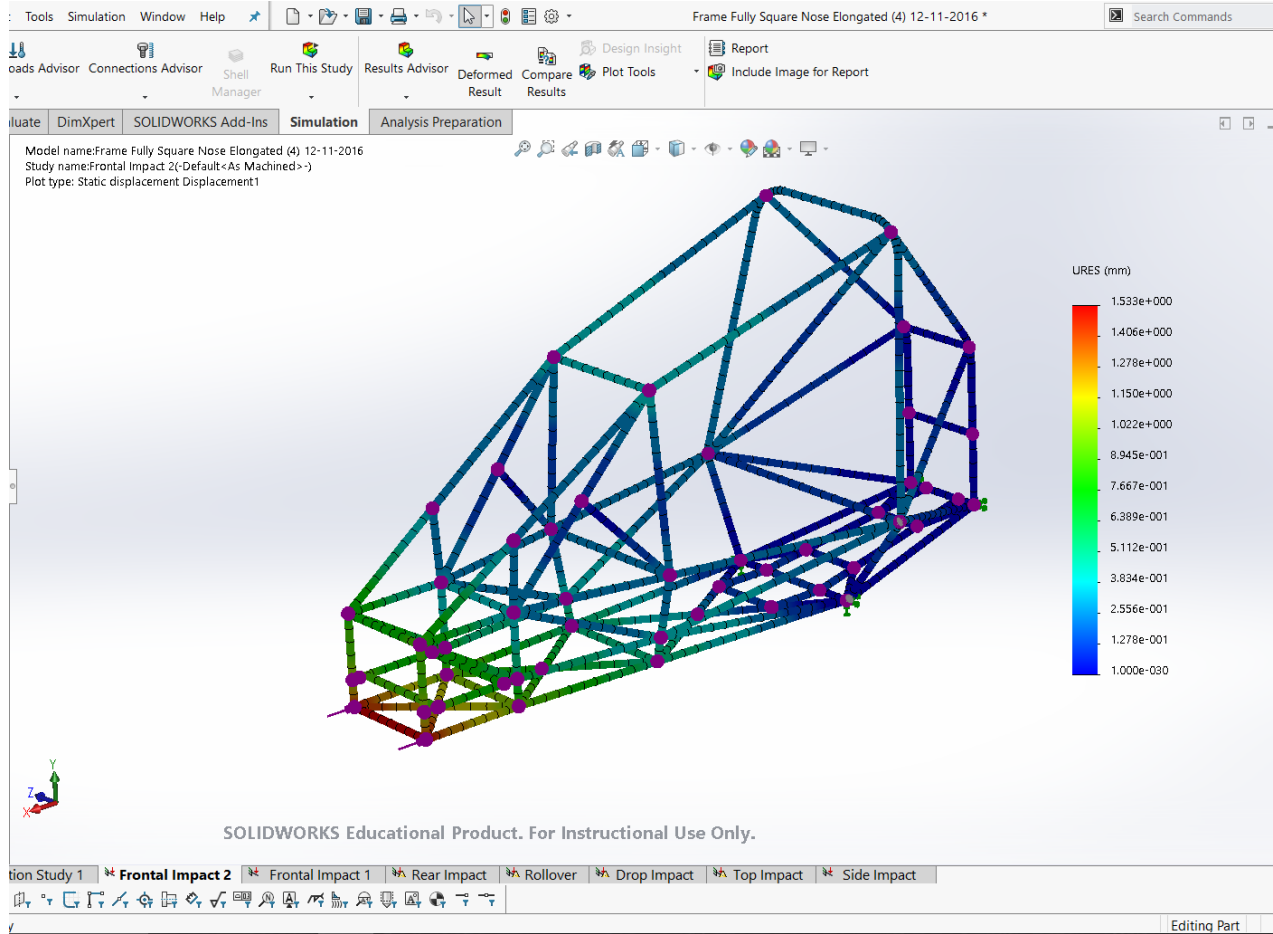

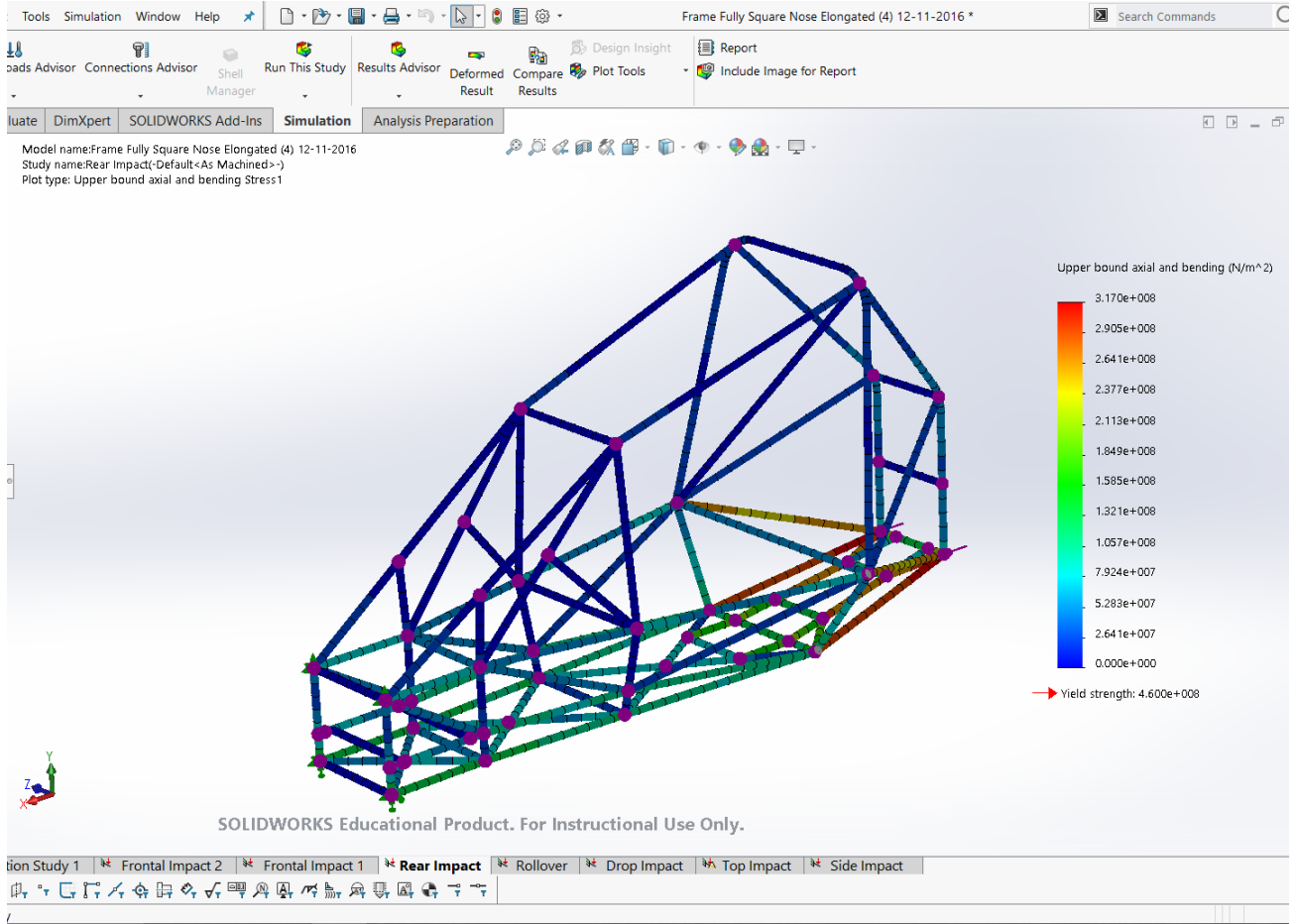

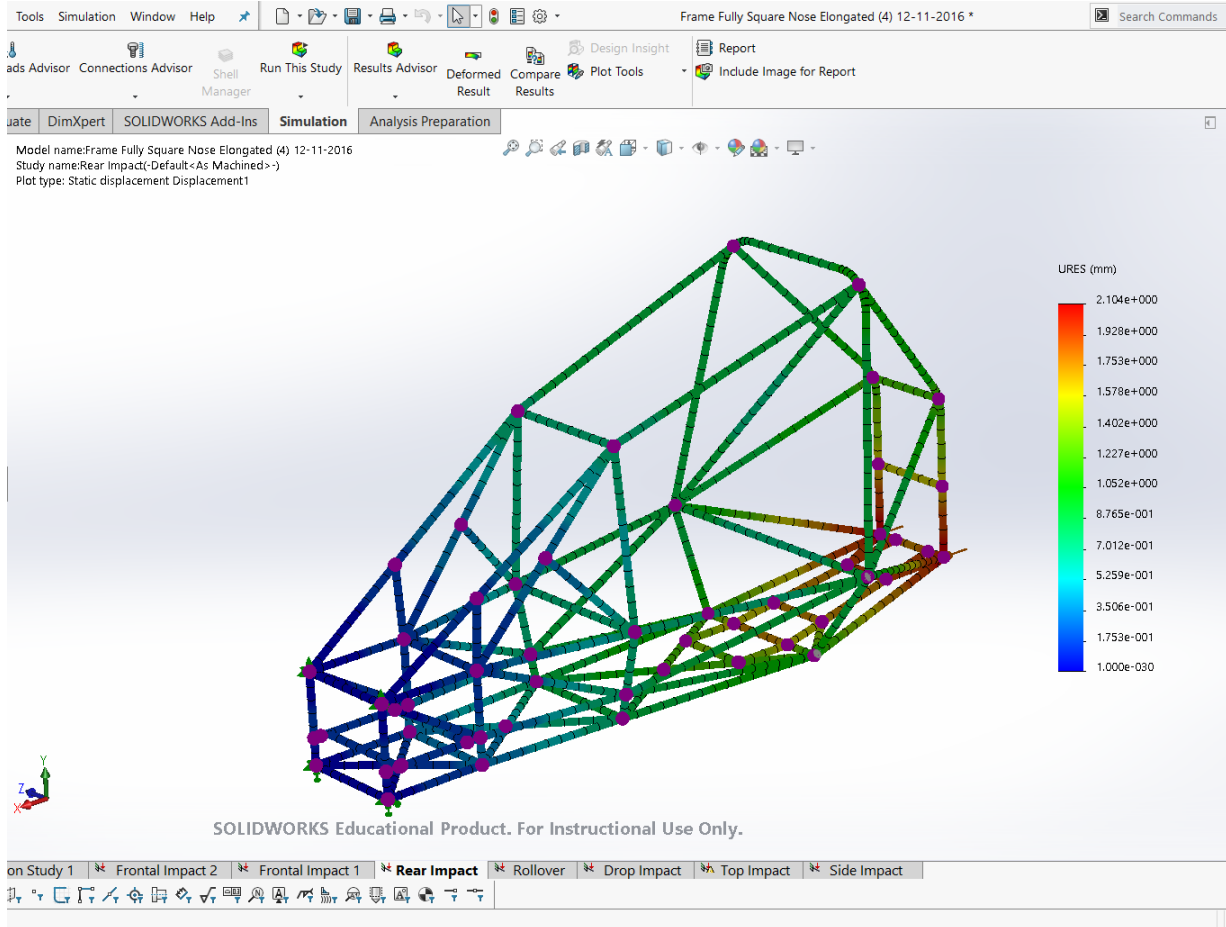

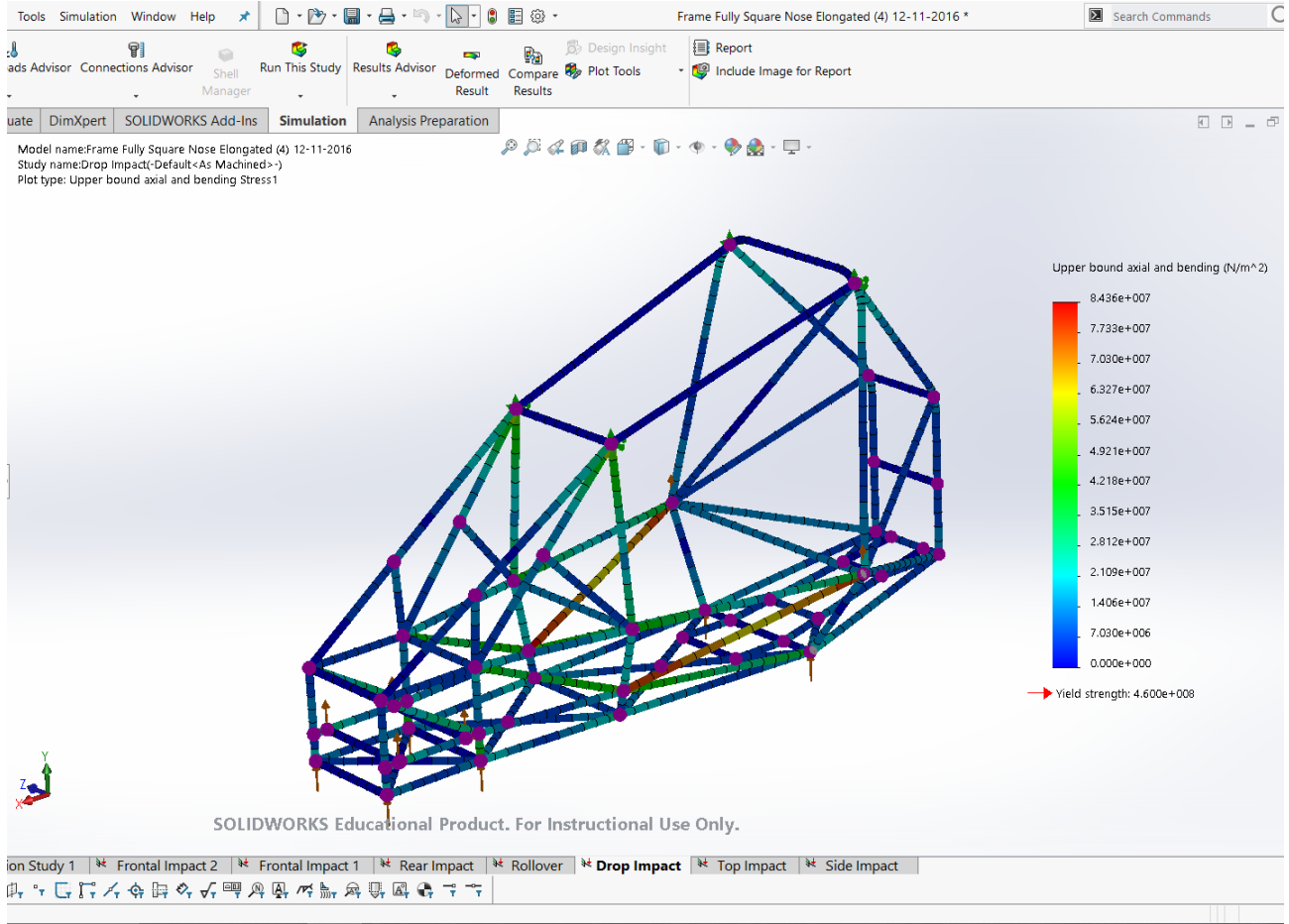

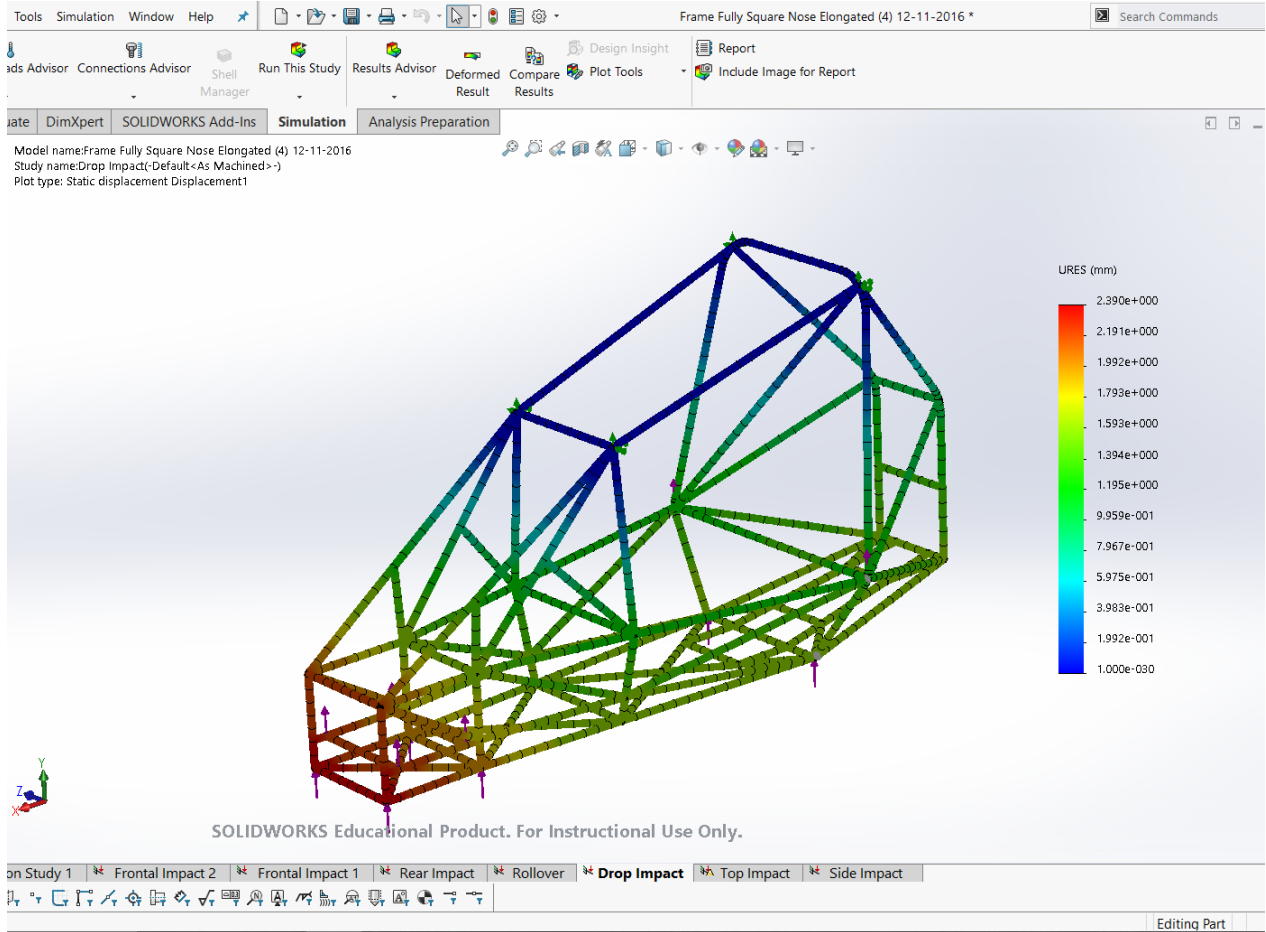

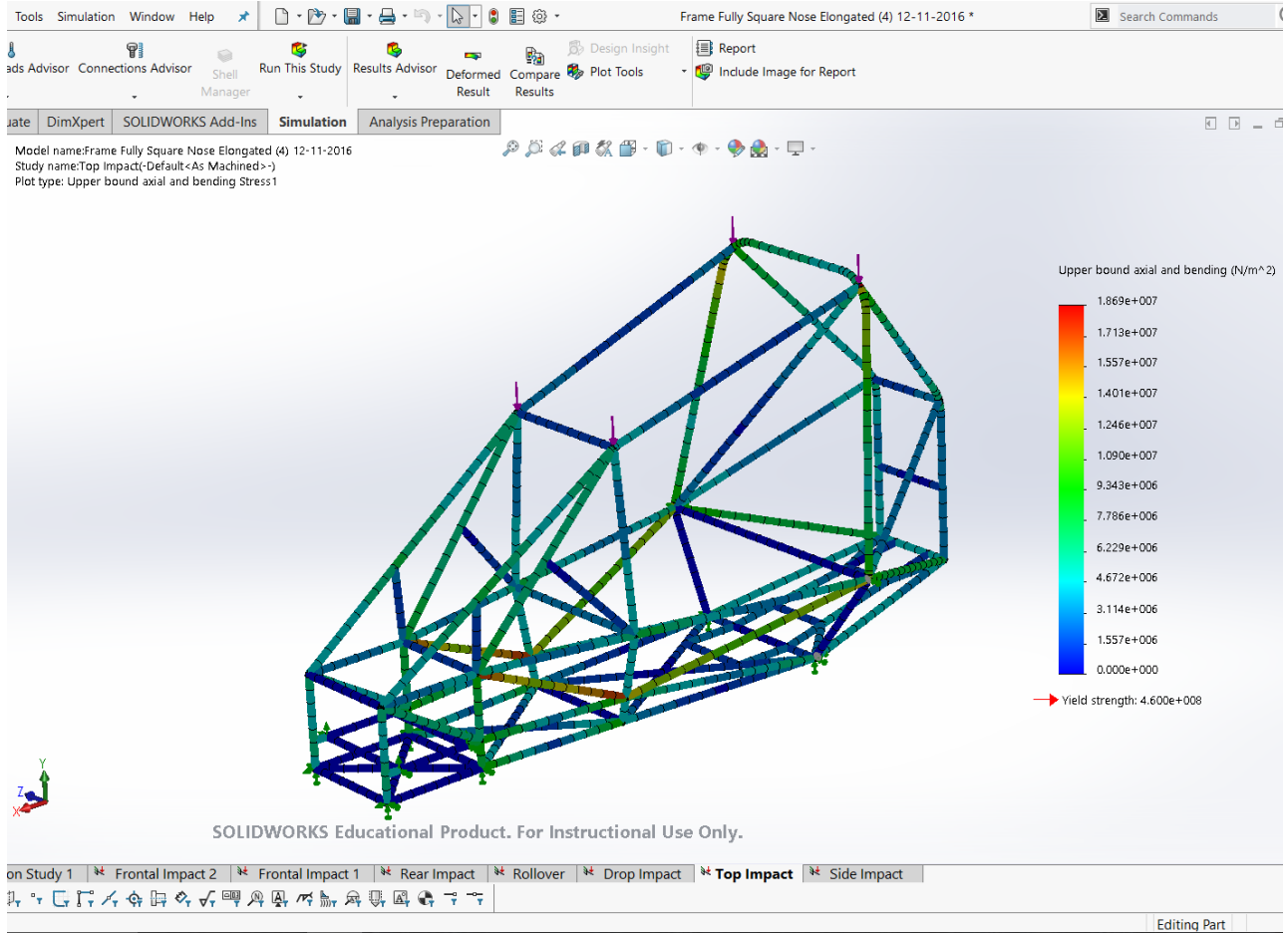

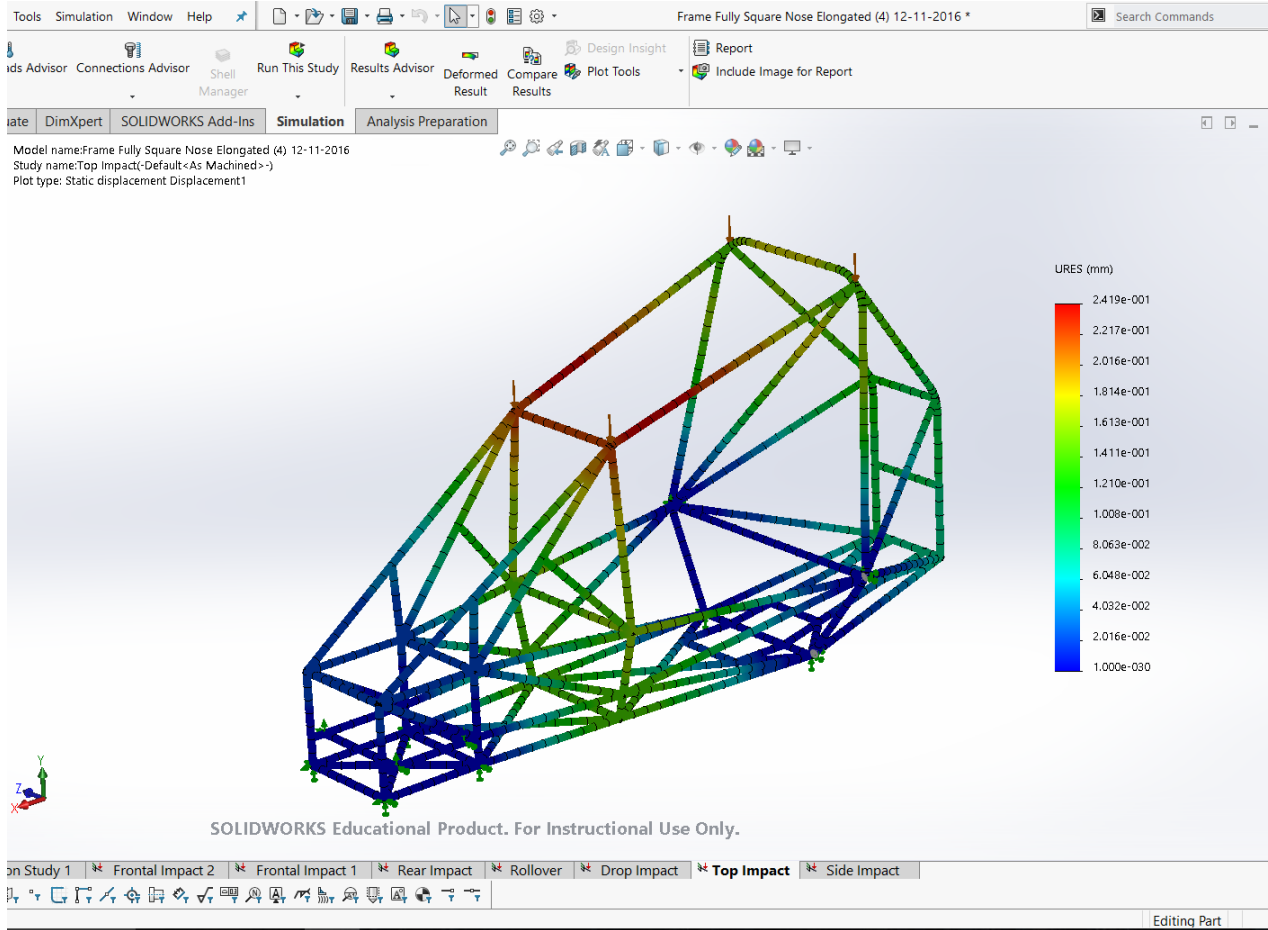

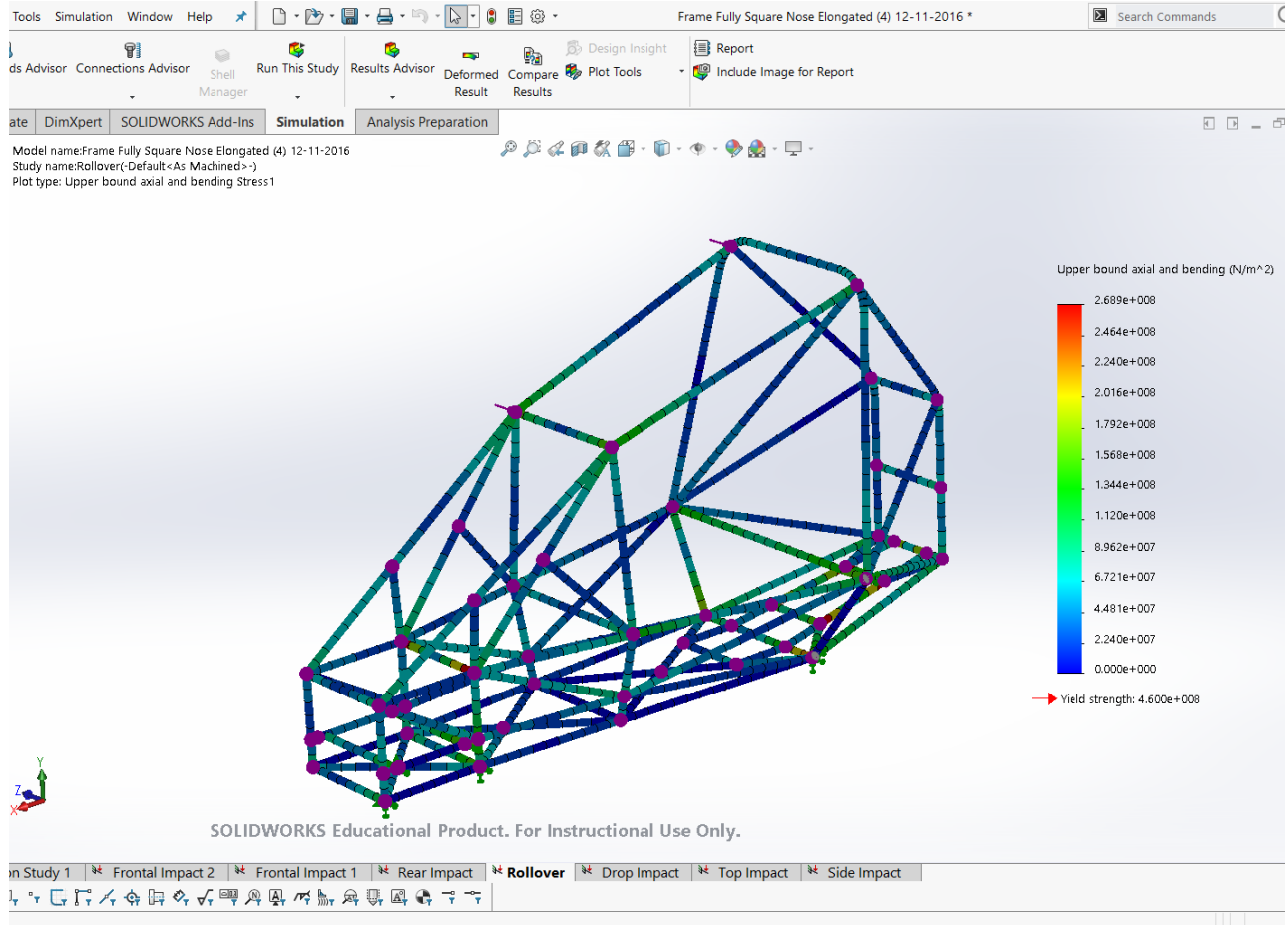

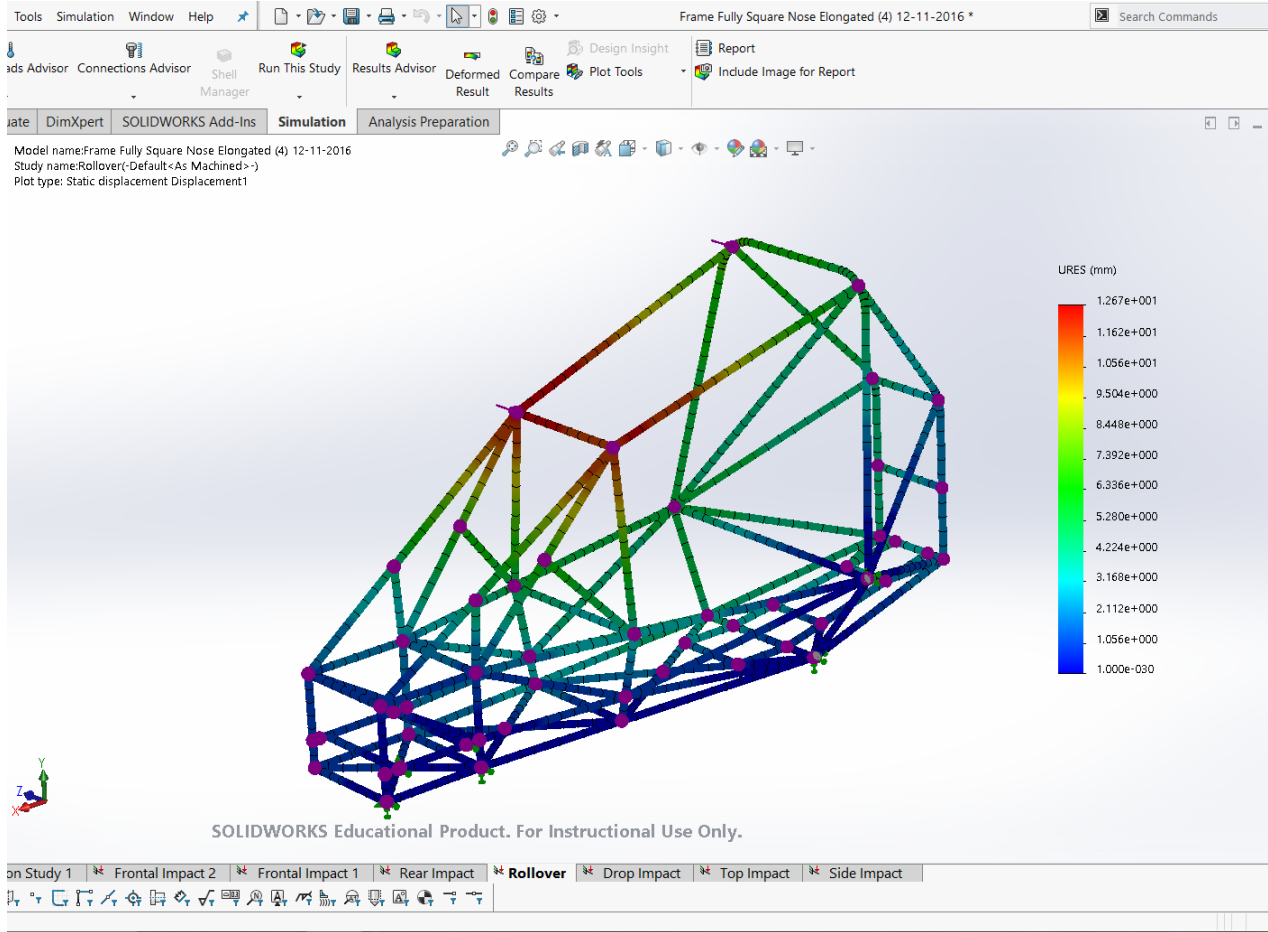

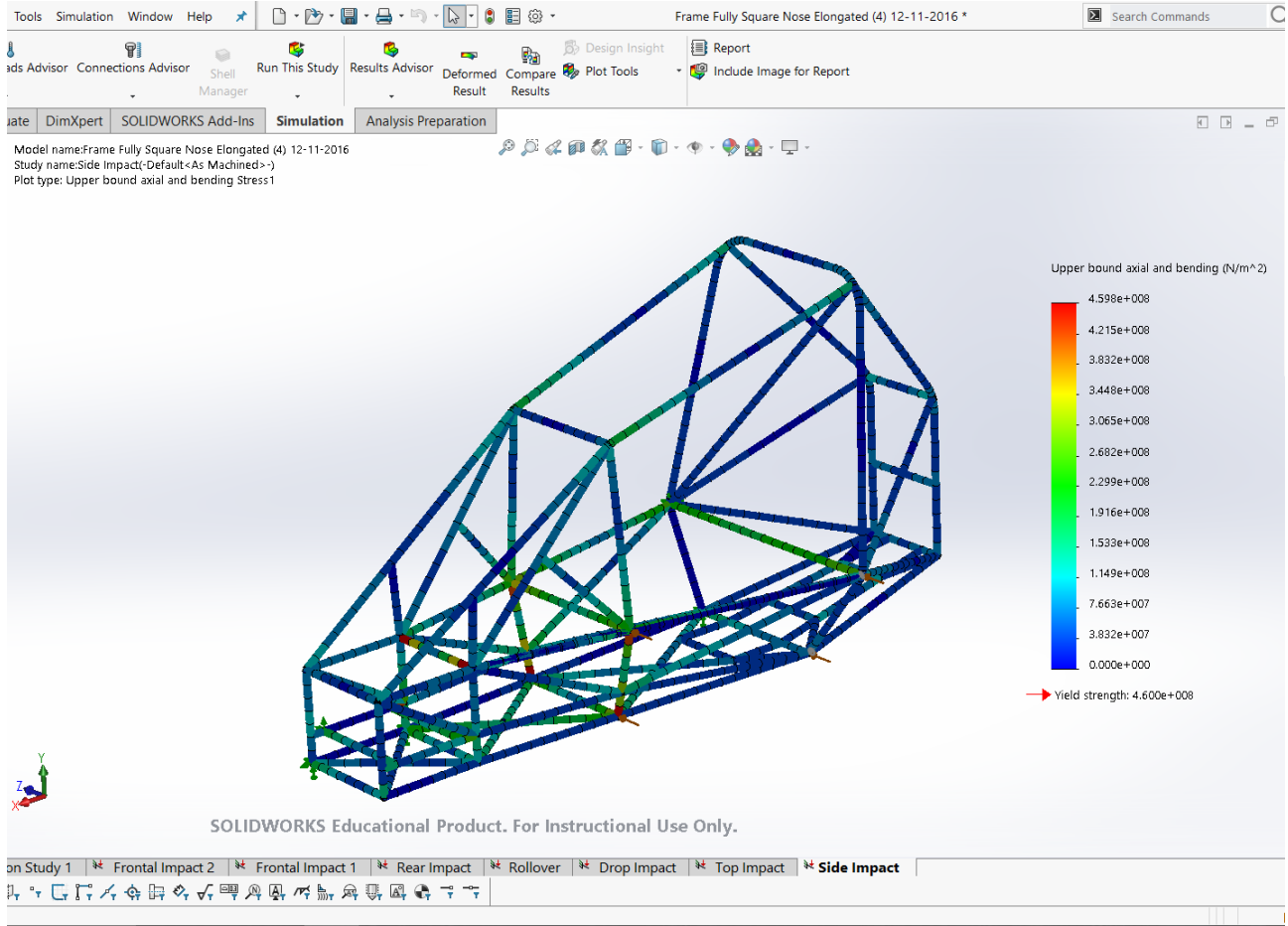

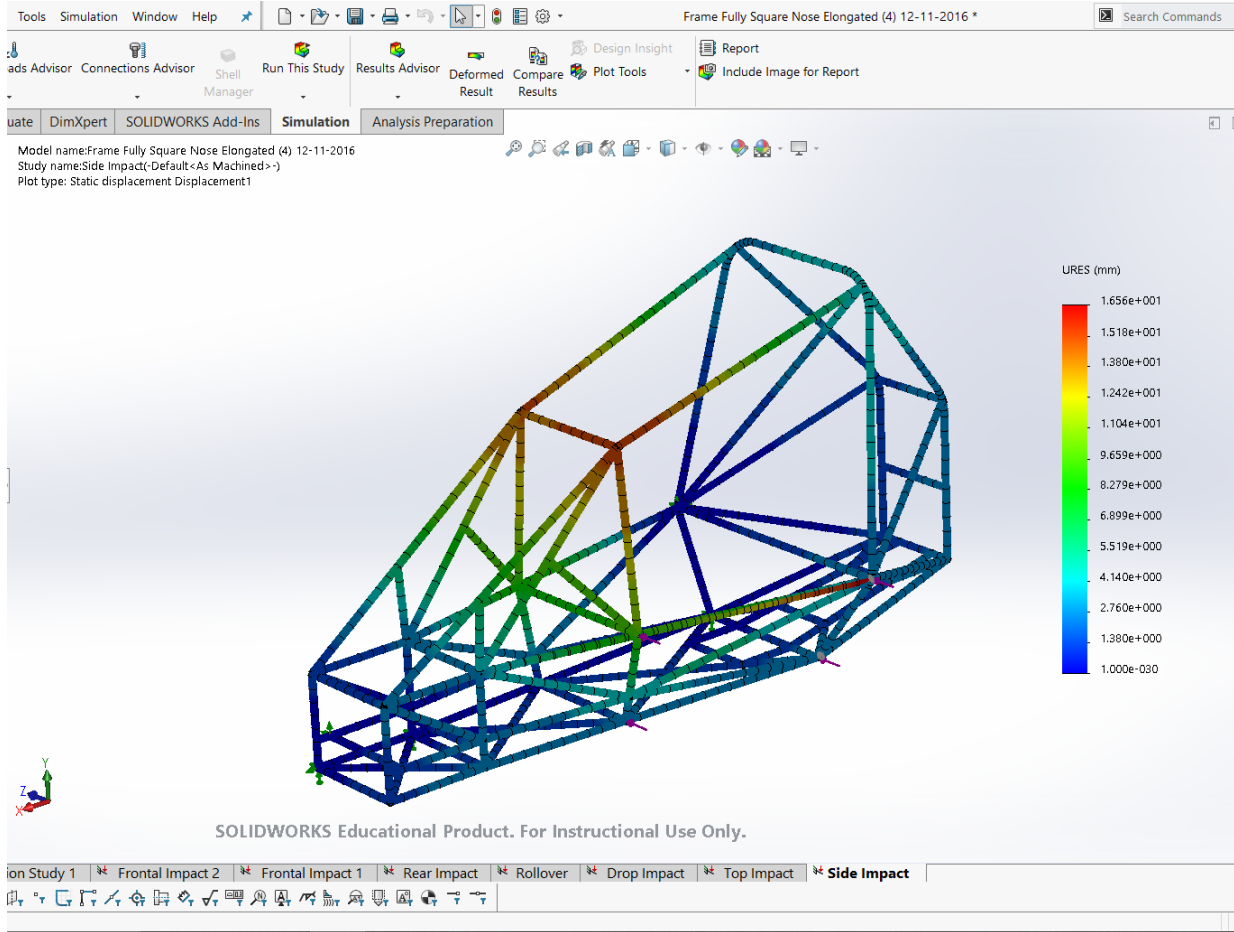

Appendix C: Final Design Simulation Reports

C1: Frontal Impact 1

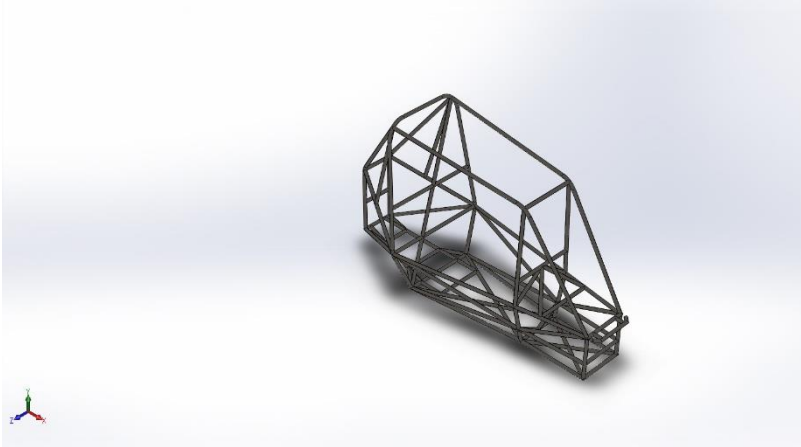

Simulation of Model C18 2-6-17

Date: Tuesday, February 7, 2017

Designer: Heather Selmer

Study name: Frontal Impact 1

Analysis type: Static

Table of Contents

| | |
|---------------------|----|
| Description | 59 |
| Study Properties | 60 |
| Units | 60 |
| Material Properties | 61 |
| Loads and Fixtures | 62 |
| Mesh information | 63 |
| Resultant Forces | 64 |
| Study Results | 65 |
| Conclusion | 67 |

Description

Simulating hitting the front of the vehicle at full speed into a stationary object or another vehicle traveling in the opposite direction.

Study Properties

| | |
|------------------------------|---|
| Study name | Frontal Impact 1 |
| Analysis type | Static |
| Mesh type | Beam Mesh |
| Solver type | Direct sparse solver |
| Inplane Effect: | Off |
| Soft Spring: | Off |
| Inertial Relief: | Off |
| Incompatible bonding options | Automatic |
| Large displacement | Off |
| Compute free body forces | On |
| Result folder | SOLIDWORKS document (C:\Users\Heather\Documents\WPI\MQP\Solidworks Files\C term models) |

Units

| | |
|---------------------|------------------|
| Unit system: | SI (MKS) |
| Length/Displacement | mm |
| Temperature | Kelvin |
| Angular velocity | Rad/sec |
| Pressure/Stress | N/m ² |

Material Properties

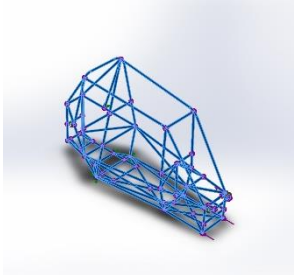
| Model Reference | Properties |
|---|--|
|  | <p>Name: AISI 4130 Steel, normalized at 870C</p> <p>Model type: Linear Elastic Isotropic</p> <p>Default failure criterion: Unknown</p> <p>Yield strength: 4.6e+008 N/m²</p> <p>Tensile strength: 7.31e+008 N/m²</p> <p>Elastic modulus: 2.05e+011 N/m²</p> <p>Poisson's ratio: 0.285</p> <p>Mass density: 7850 kg/m³</p> <p>Shear modulus: 8e+010 N/m²</p> |

Loads and Fixtures

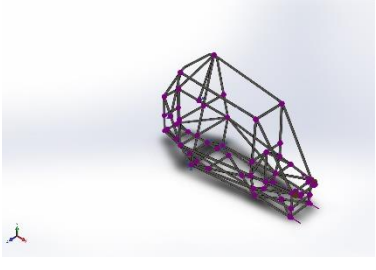
| Fixture name | Fixture Image | Fixture Details |
|-----------------------|---|---|
| <p>Fixed-1</p> |  | <p>Entities: 6 Joint(s) Type: Fixed Geometry</p> |

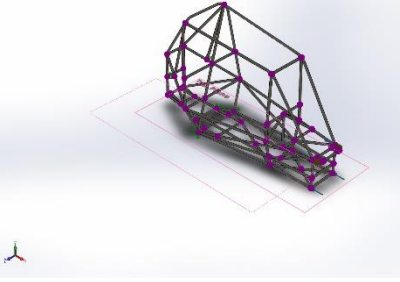
| Load name | Load Image | Load Details |
|-----------------------|--|---|
| <p>Force-1</p> |  | <p>Entities: 1 plane(s), 4 Joint(s) Reference: Top Plane Type: Apply force Values: -25000, ---, --- N Moments: ---, ---, --- N.m</p> |

Mesh information

| | |
|-----------|-----------|
| Mesh type | Beam Mesh |
|-----------|-----------|

Mesh information - Details

| | |
|----------------------------------|----------|
| Total Nodes | 1289 |
| Total Elements | 1052 |
| Time to complete mesh(hh:mm:ss): | 00:00:06 |
| Computer name: | |

Model name:Model C18 2-6-17
 Study name:Frontal Impact 1(-Default<As Machined>-)
 Mesh type:

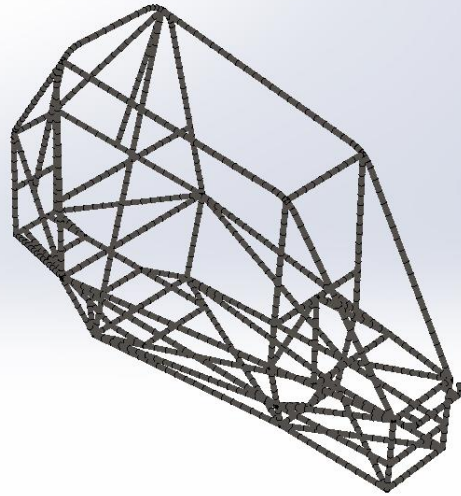

SOLIDWORKS Educational Product. For Instructional Use Only.

Resultant Forces

Reaction forces

| Selection set | Units | Sum X | Sum Y | Sum Z | Resultant |
|---------------|-------|--------|--------------|-------|-----------|
| Entire Model | N | 100000 | -0.000244141 | 0 | 100000 |

Reaction Moments

| Selection set | Units | Sum X | Sum Y | Sum Z | Resultant |
|---------------|-------|---------|---------|----------|-----------|
| Entire Model | N.m | -9.8245 | 4.51491 | -246.901 | 247.138 |

Study Results

| Name | Type | Min | Max |
|----------------|----------------------------------|-----------------------------------|---|
| Stress1 | TXY: Shear in Y Dir. on YZ Plane | 0 N/m ² Element: 83 | 2.78408e+008 N/m ² Element: 909 |

Model name: Model C18 2-6-17
 Study name: Frontal Impact 1(-Default<As Machined>-)
 Plot type: Upper bound axial and bending Stress1
 Deformation scale: 103.886

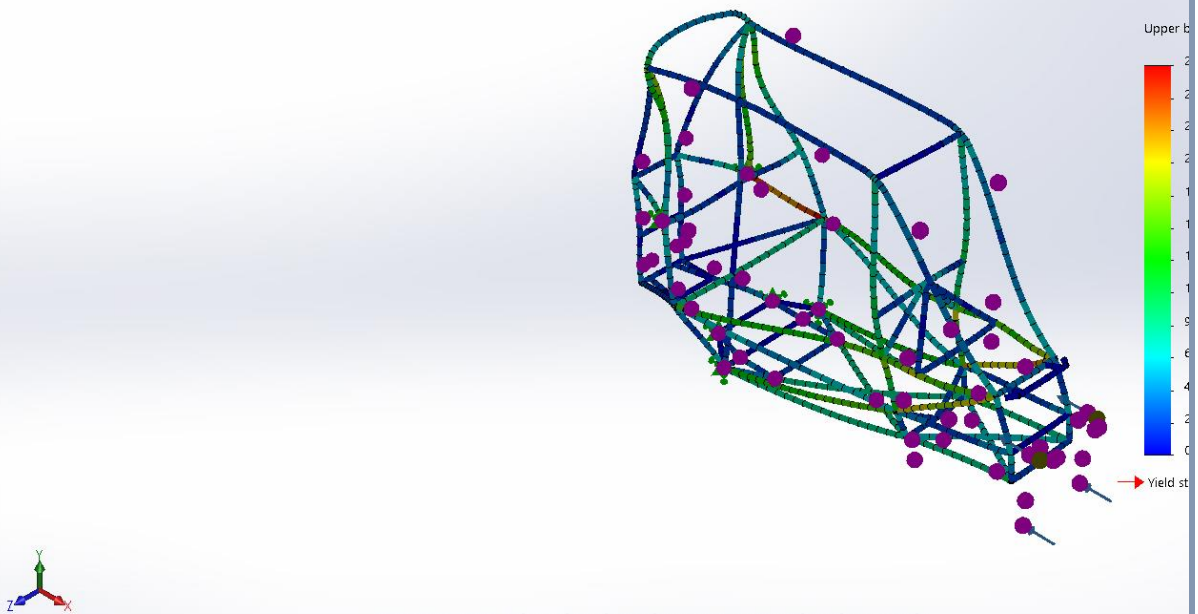

Model C18 2-6-17-Frontal Impact 1-Stress-Stress1

| Name | Type | Min | Max |
|----------------------|------------------------------|------------------|-------------------------|
| Displacement1 | URES: Resultant Displacement | 0 mm Node: 87 | 2.69771 mm Node: 176 |

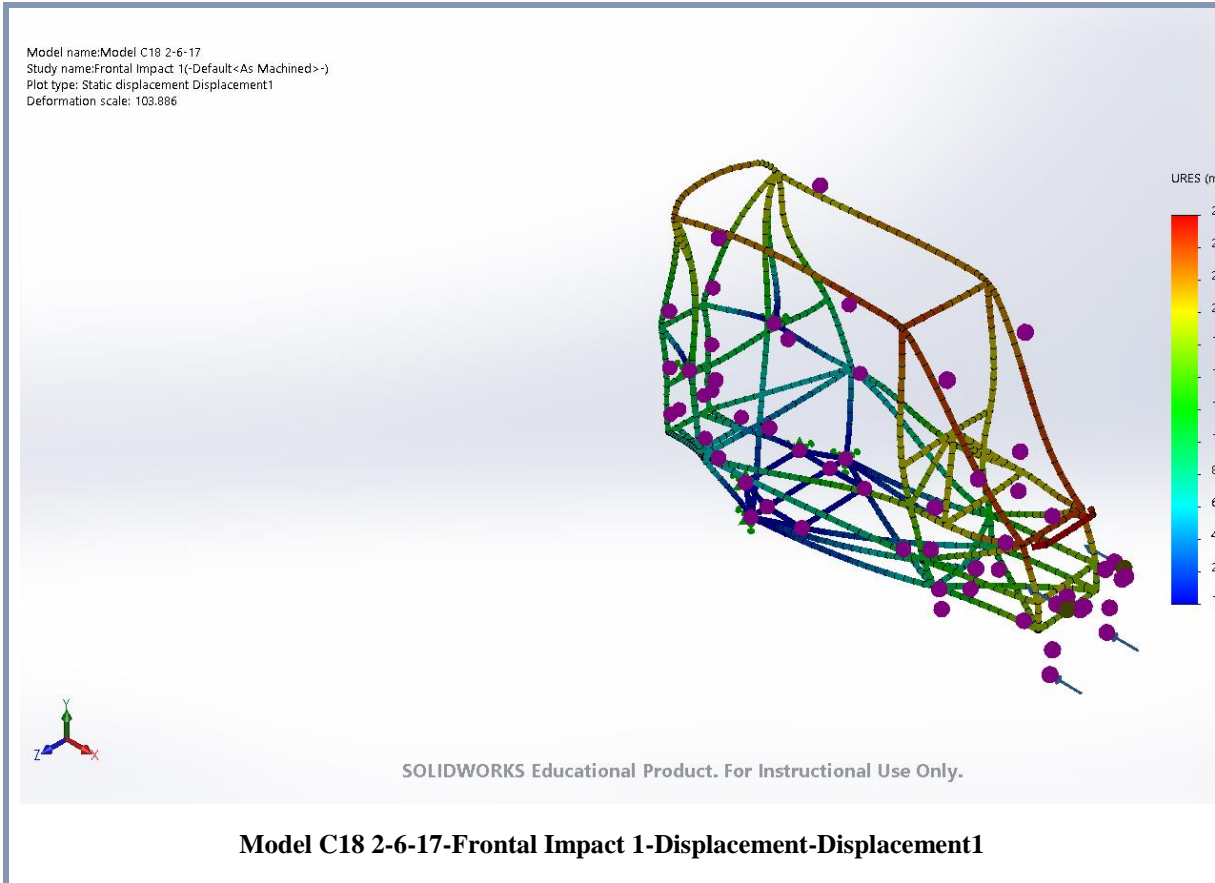

| Name | Type |
|------------------|----------------|
| Displacement1{1} | Deformed shape |

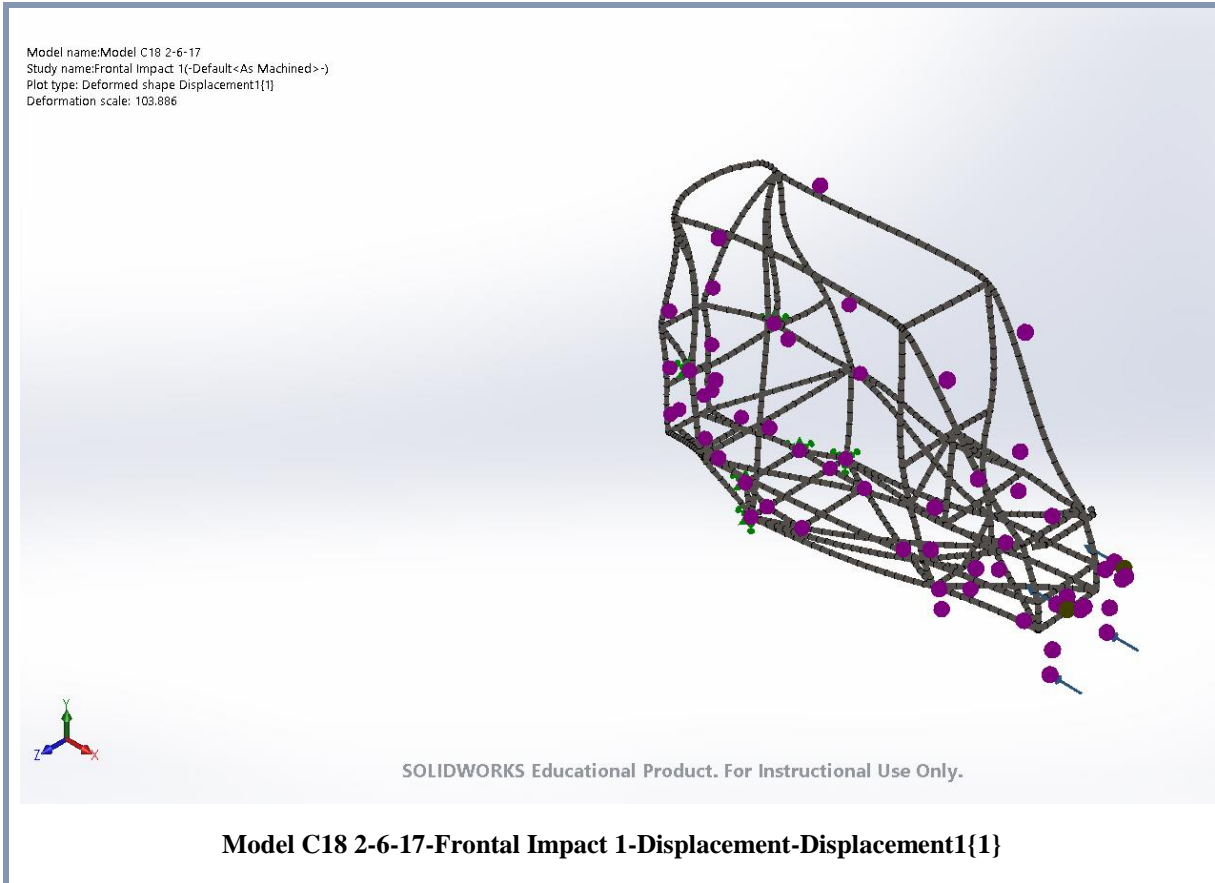

Conclusion

The stress on any one beam never exceeds the yield strength of the material, and so the model is safe in this type of impact.

C2: Frontal Impact 2

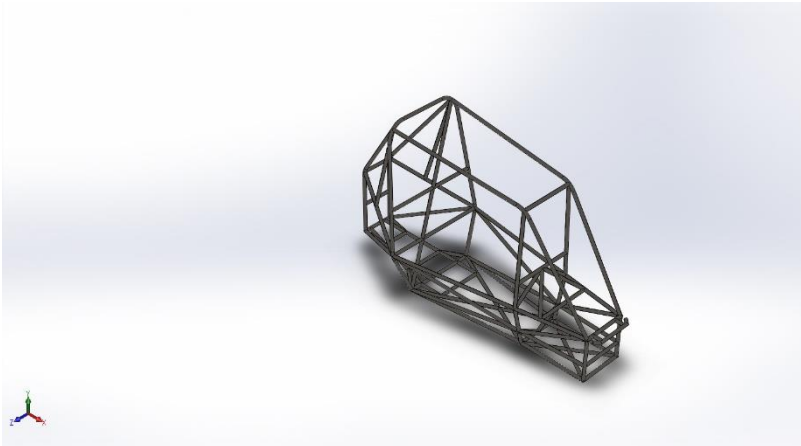

Simulation of Model C18 2-6-17

Date: Tuesday, February 7, 2017

Designer: Heather Selmer

Study name: Frontal Impact 2

Analysis type: Static

Table of Contents

| | |
|---------------------|----|
| Description | 68 |
| Study Properties | 69 |
| Units | 69 |
| Material Properties | 70 |
| Loads and Fixtures | 71 |
| Mesh information | 72 |
| Resultant Forces | 73 |
| Study Results | 74 |
| Conclusion | 75 |

Description

Simulating the effect of hitting a stationary object at full speed with only the bottom of the frame.

Study Properties

| | |
|------------------------------|---|
| Study name | Frontal Impact 2 |
| Analysis type | Static |
| Mesh type | Beam Mesh |
| Solver type | Direct sparse solver |
| Inplane Effect: | Off |
| Soft Spring: | Off |
| Inertial Relief: | Off |
| Incompatible bonding options | Automatic |
| Large displacement | Off |
| Compute free body forces | On |
| Result folder | SOLIDWORKS document (C:\Users\Heather\Documents\WPI\MQP\Solidworks Files\C term models) |

Units

| | |
|---------------------|------------------|
| Unit system: | SI (MKS) |
| Length/Displacement | mm |
| Temperature | Kelvin |
| Angular velocity | Rad/sec |
| Pressure/Stress | N/m ² |

Material Properties

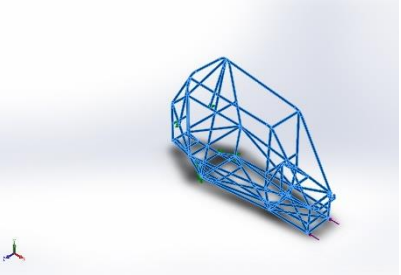
| Model Reference | Properties |
|---|--|
|  | <p>Name: AISI 4130 Steel, normalized at 870C</p> <p>Model type: Linear Elastic Isotropic</p> <p>Default failure criterion: Unknown</p> <p>Yield strength: 4.6e+008 N/m²</p> <p>Tensile strength: 7.31e+008 N/m²</p> <p>Elastic modulus: 2.05e+011 N/m²</p> <p>Poisson's ratio: 0.285</p> <p>Mass density: 7850 kg/m³</p> <p>Shear modulus: 8e+010 N/m²</p> |

Loads and Fixtures

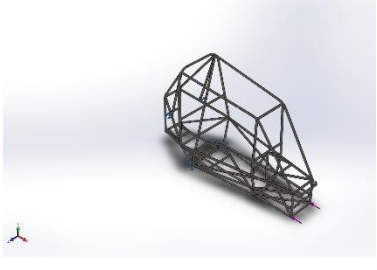
| Fixture name | Fixture Image | Fixture Details |
|----------------|---|--|
| Fixed-1 |  | Entities: 6 Joint(s) Type: Fixed Geometry |

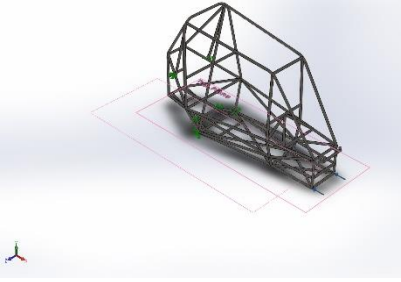
| Load name | Load Image | Load Details |
|----------------|--|--|
| Force-1 |  | Entities: 1 plane(s), 2 Joint(s) Reference: Top Plane Type: Apply force Values: -50000, ---, --- N Moments: ---, ---, --- N.m |

Mesh information

| | |
|-----------|-----------|
| Mesh type | Beam Mesh |
|-----------|-----------|

Mesh information - Details

| | |
|----------------------------------|----------|
| Total Nodes | 1289 |
| Total Elements | 1052 |
| Time to complete mesh(hh:mm:ss): | 00:00:05 |
| Computer name: | |

Model name:Model C18 2-6-17
 Study name:Frontal Impact 2(-Default<As Machined>-)
 Mesh type:

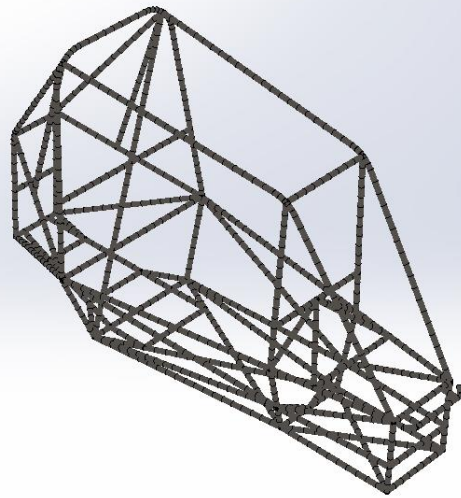

SOLIDWORKS Educational Product. For Instructional Use Only.

Resultant Forces

Reaction forces

| Selection set | Units | Sum X | Sum Y | Sum Z | Resultant |
|---------------|-------|--------|--------------|--------------|-----------|
| Entire Model | N | 100000 | 6.10352e-005 | -0.000335693 | 100000 |

Reaction Moments

| Selection set | Units | Sum X | Sum Y | Sum Z | Resultant |
|---------------|-------|---------|----------|----------|-----------|
| Entire Model | N.m | 2.01759 | -1.87188 | -1.28406 | 3.03701 |

Study Results

| Name | Type | Min | Max |
|----------------|----------------------------------|-----------------------------------|---|
| Stress1 | TXY: Shear in Y Dir. on YZ Plane | 0 N/m ² Element: 83 | 3.01231e+008 N/m ² Element: 788 |

Model name: Model C18 2-6-17
 Study name: Frontal Impact 2(-Default<As Machined>-)
 Plot type: Upper bound axial and bending Stress1
 Deformation scale: 176.093

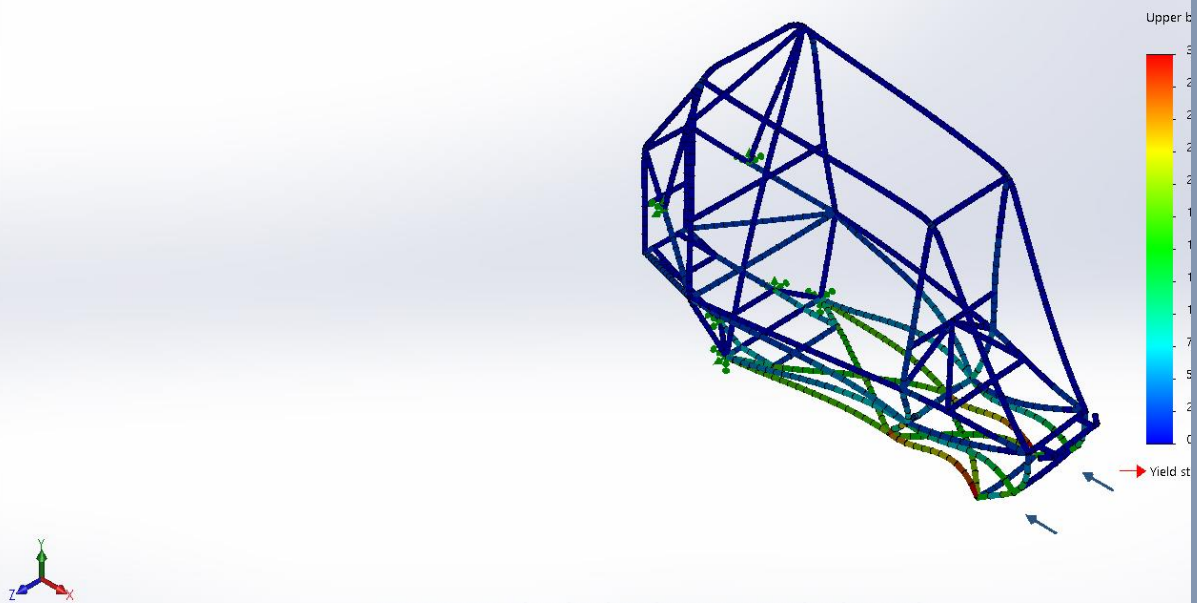

SOLIDWORKS Educational Product. For Instructional Use Only.

Model C18 2-6-17-Frontal Impact 2-Stress-Stress1

| Name | Type | Min | Max |
|----------------------|------------------------------|------------------|------------------------|
| Displacement1 | URES: Resultant Displacement | 0 mm Node: 87 | 1.3561 mm Node: 103 |

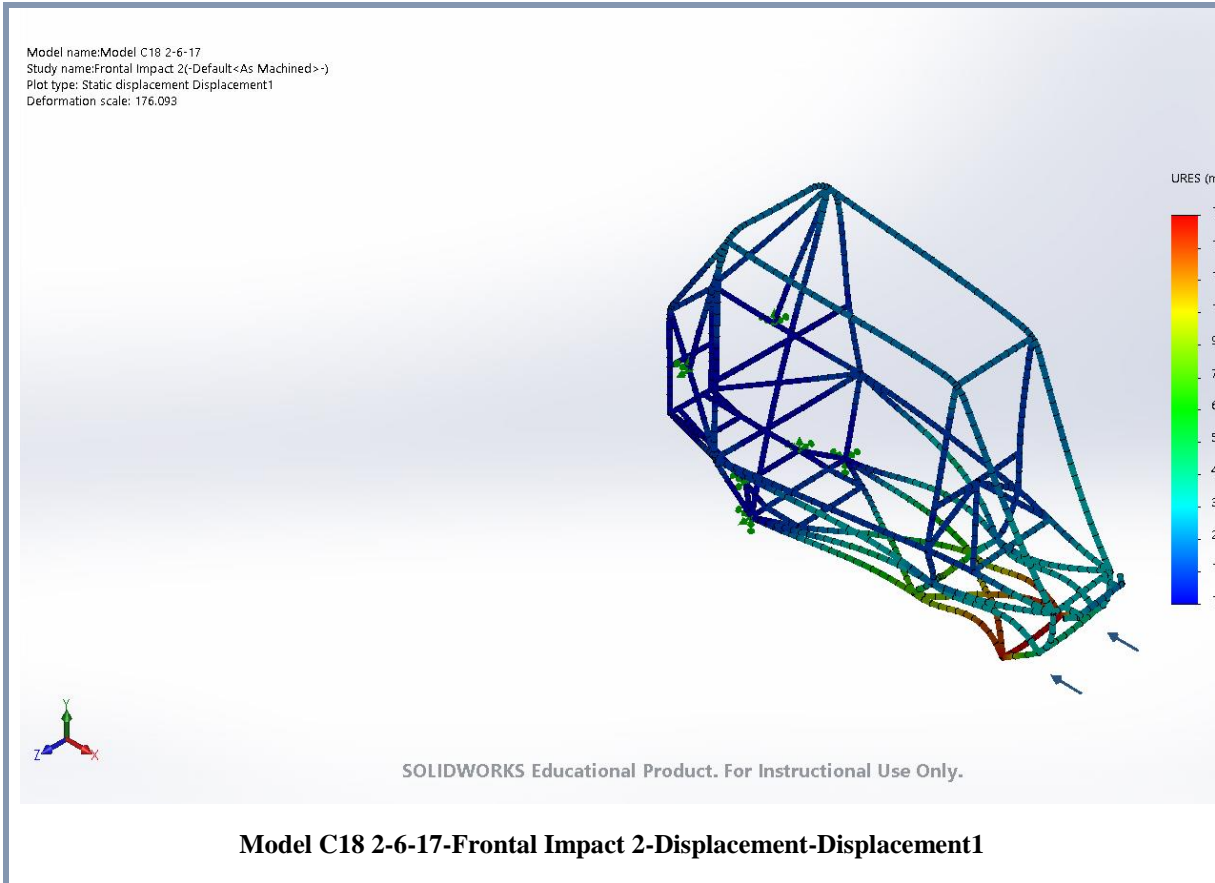

Conclusion

The stress on any one beam never exceeds the yield strength of the material, and so the model is safe in this type of impact.

C3: Rear Impact

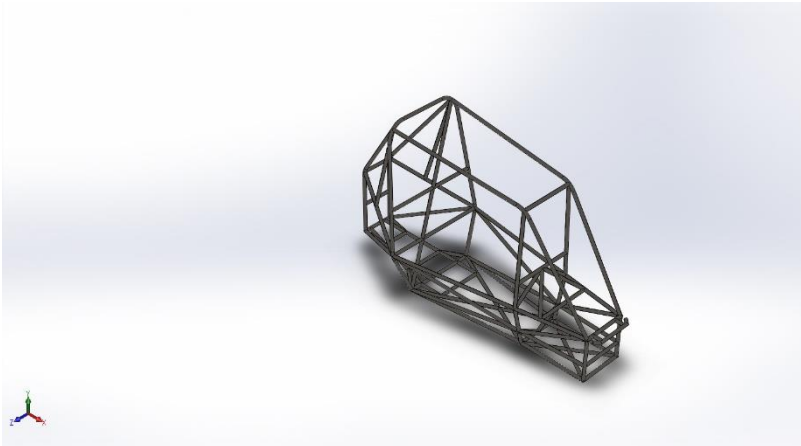

Simulation of Model C18 2-6-17

Date: Tuesday, February 7, 2017

Designer: Heather Selmer

Study name: Rear Impact

Analysis type: Static

Table of Contents

| | |
|---------------------|----|
| Description | 76 |
| Study Properties | 77 |
| Units | 77 |
| Material Properties | 78 |
| Loads and Fixtures | 79 |
| Mesh information | 80 |
| Resultant Forces | 81 |
| Study Results | 82 |
| Conclusion | 83 |

Description

Simulating being impacted from behind and the rear suspension taking the force of stopping the vehicle.

Study Properties

| | |
|------------------------------|---|
| Study name | Rear Impact |
| Analysis type | Static |
| Mesh type | Beam Mesh |
| Solver type | Direct sparse solver |
| Inplane Effect: | Off |
| Soft Spring: | Off |
| Inertial Relief: | Off |
| Incompatible bonding options | Automatic |
| Large displacement | Off |
| Compute free body forces | On |
| Result folder | SOLIDWORKS document (C:\Users\Heather\Documents\WPI\MQP\Solidworks Files\C term models) |

Units

| | |
|---------------------|------------------|
| Unit system: | SI (MKS) |
| Length/Displacement | mm |
| Temperature | Kelvin |
| Angular velocity | Rad/sec |
| Pressure/Stress | N/m ² |

Material Properties

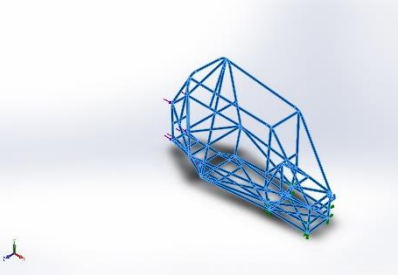
| Model Reference | Properties |
|---|---|
|  | <p data-bbox="857 373 1187 436">Name: AISI 4130 Steel, normalized at 870C</p> <p data-bbox="797 457 1235 489">Model type: Linear Elastic Isotropic</p> <p data-bbox="768 510 1073 573">Default failure criterion: Unknown</p> <p data-bbox="764 594 1149 625">Yield strength: 4.6e+008 N/m²</p> <p data-bbox="743 646 1162 678">Tensile strength: 7.31e+008 N/m²</p> <p data-bbox="743 699 1162 730">Elastic modulus: 2.05e+011 N/m²</p> <p data-bbox="760 751 1024 783">Poisson's ratio: 0.285</p> <p data-bbox="776 804 1105 835">Mass density: 7850 kg/m³</p> <p data-bbox="751 856 1130 888">Shear modulus: 8e+010 N/m²</p> |

Loads and Fixtures

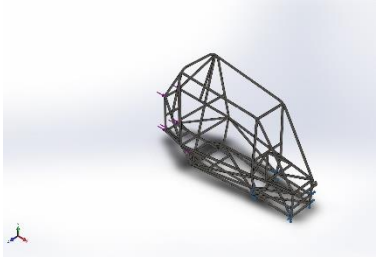
| Fixture name | Fixture Image | Fixture Details |
|----------------|---|--|
| Fixed-1 |  | Entities: 8 Joint(s) Type: Fixed Geometry |

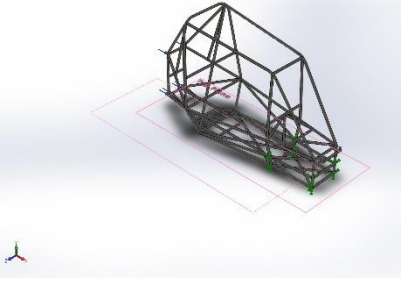
| Load name | Load Image | Load Details |
|----------------|--|--|
| Force-1 |  | Entities: 1 plane(s), 8 Joint(s) Reference: Top Plane Type: Apply force Values: 9500, ---, --- N Moments: ---, ---, --- N.m |

Mesh information

| | |
|-----------|-----------|
| Mesh type | Beam Mesh |
|-----------|-----------|

Mesh information - Details

| | |
|----------------------------------|----------|
| Total Nodes | 1289 |
| Total Elements | 1052 |
| Time to complete mesh(hh:mm:ss): | 00:00:05 |
| Computer name: | |

Model name:Model C18 2-6-17
 Study name:Rear Impact(-Default-<As Machined>-)
 Mesh type:

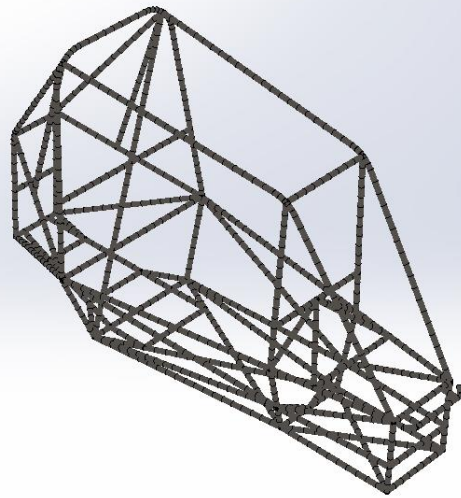

SOLIDWORKS Educational Product. For Instructional Use Only.

Resultant Forces

Reaction forces

| Selection set | Units | Sum X | Sum Y | Sum Z | Resultant |
|---------------|-------|--------|--------------|-------------|-----------|
| Entire Model | N | -76000 | -0.000976563 | -0.00012207 | 76000 |

Reaction Moments

| Selection set | Units | Sum X | Sum Y | Sum Z | Resultant |
|---------------|-------|----------|----------|---------|-----------|
| Entire Model | N.m | -6.01998 | -0.41435 | 377.039 | 377.088 |

Study Results

| Name | Type | Min | Max |
|----------------|----------------------------------|-----------------------------------|---|
| Stress1 | TXY: Shear in Y Dir. on YZ Plane | 0 N/m ² Element: 17 | 4.43781e+008 N/m ² Element: 824 |

Model name: Model C18 2-6-17
 Study name: Rear Impact(-Default-<As Machined>-)
 Plot type: Upper bound axial and bending Stress1
 Deformation scale: 39.7026

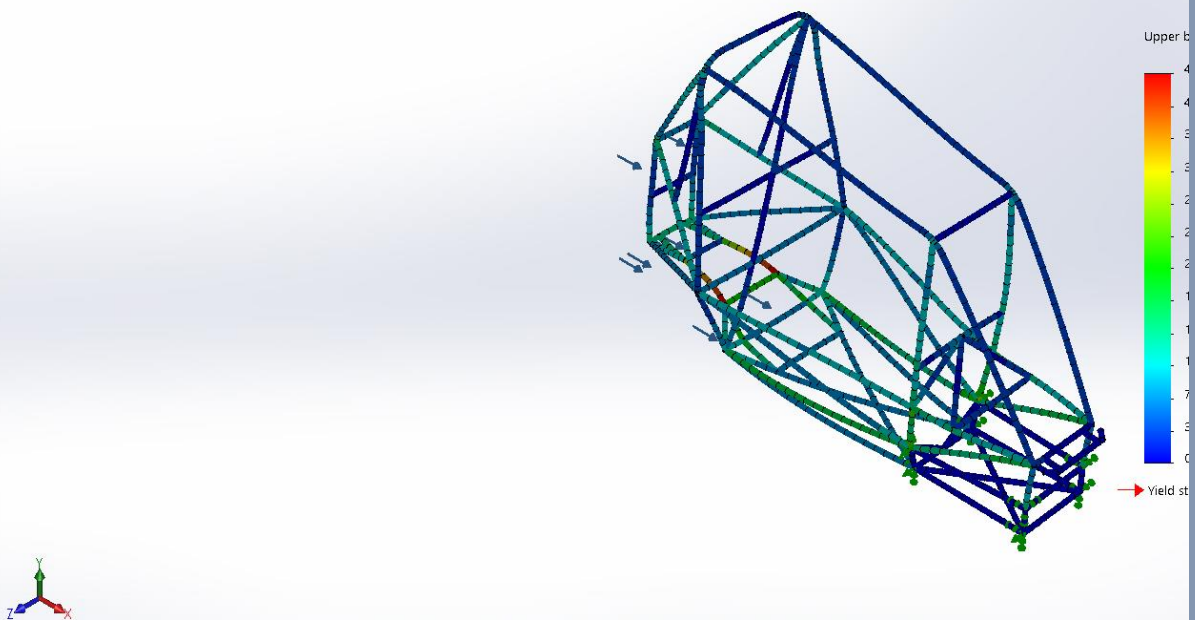

SOLIDWORKS Educational Product. For Instructional Use Only.

Model C18 2-6-17-Rear Impact-Stress-Stress1

| Name | Type | Min | Max |
|----------------------|------------------------------|-----------------|-------------------------|
| Displacement1 | URES: Resultant Displacement | 0 mm Node: 9 | 5.95864 mm Node: 791 |

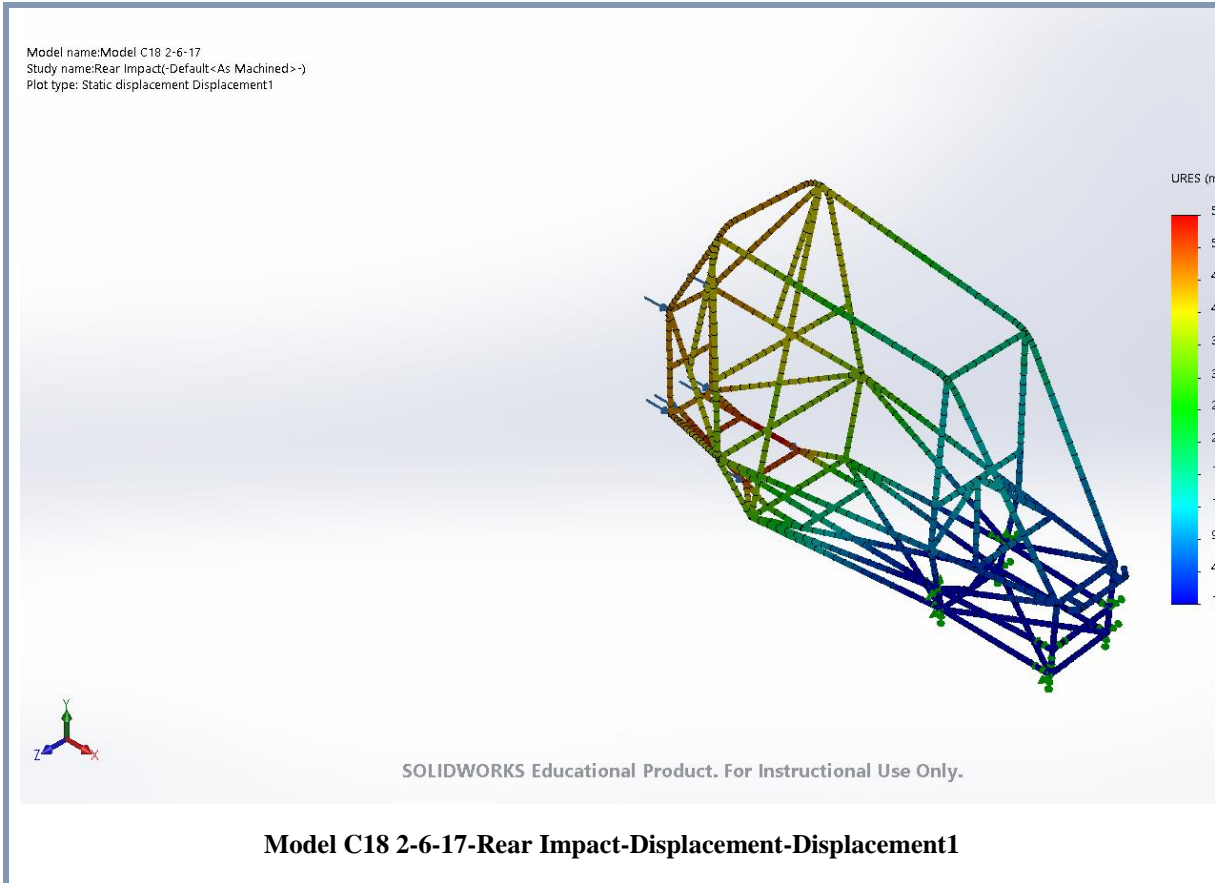

Conclusion

The stress on any one beam never exceeds the yield strength of the material, and so the model is safe in this type of impact.

C4: Rollover

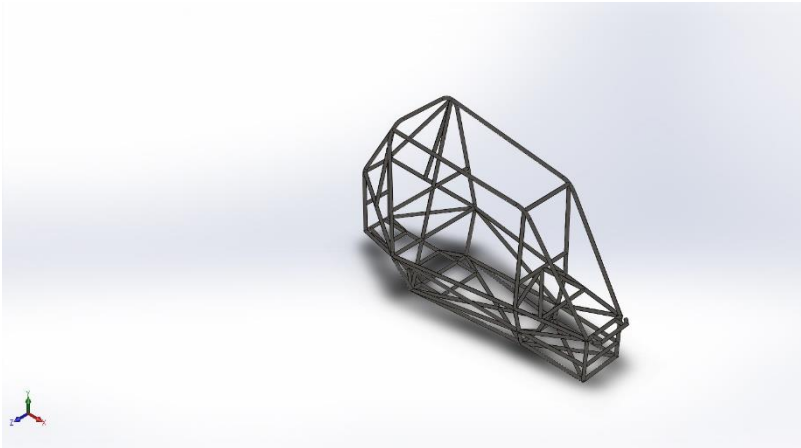

Simulation of Model C18 2-6-17

Date: Tuesday, February 7, 2017

Designer: Heather Selmer

Study name: Rollover

Analysis type: Static

Table of Contents

| | |
|---------------------|----|
| Description | 84 |
| Study Properties | 85 |
| Units | 85 |
| Material Properties | 86 |
| Loads and Fixtures | 87 |
| Mesh information | 88 |
| Resultant Forces | 89 |
| Study Results | 90 |
| Conclusion | 91 |

Description

Simulating rolling and impacting the top of the roll cage in a sideways direction.

Study Properties

| | |
|------------------------------|---|
| Study name | Rollover |
| Analysis type | Static |
| Mesh type | Beam Mesh |
| Solver type | Direct sparse solver |
| Inplane Effect: | Off |
| Soft Spring: | Off |
| Inertial Relief: | Off |
| Incompatible bonding options | Automatic |
| Large displacement | Off |
| Compute free body forces | On |
| Result folder | SOLIDWORKS document (C:\Users\Heather\Documents\WPI\MQP\Solidworks Files\C term models) |

Units

| | |
|---------------------|------------------|
| Unit system: | SI (MKS) |
| Length/Displacement | mm |
| Temperature | Kelvin |
| Angular velocity | Rad/sec |
| Pressure/Stress | N/m ² |

Material Properties

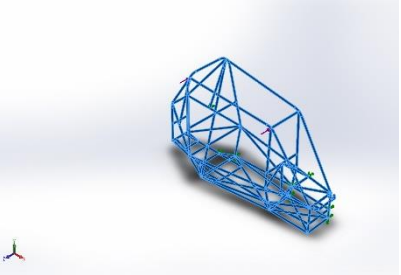
| Model Reference | Properties |
|---|--|
|  | <p>Name: AISI 4130 Steel, normalized at 870C</p> <p>Model type: Linear Elastic Isotropic</p> <p>Default failure criterion: Unknown</p> <p>Yield strength: 4.6e+008 N/m²</p> <p>Tensile strength: 7.31e+008 N/m²</p> <p>Elastic modulus: 2.05e+011 N/m²</p> <p>Poisson's ratio: 0.285</p> <p>Mass density: 7850 kg/m³</p> <p>Shear modulus: 8e+010 N/m²</p> |

Loads and Fixtures

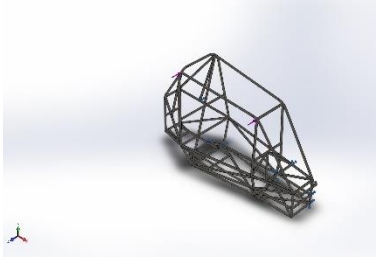
| Fixture name | Fixture Image | Fixture Details |
|----------------|---|--|
| Fixed-1 |  | Entities: 8 Joint(s) Type: Fixed Geometry |

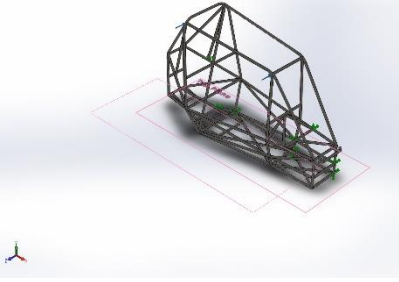
| Load name | Load Image | Load Details |
|----------------|--|--|
| Force-1 |  | Entities: 1 plane(s), 2 Joint(s) Reference: Top Plane Type: Apply force Values: ---, 2500, --- N Moments: ---, ---, --- N.m |

Mesh information

| | |
|-----------|-----------|
| Mesh type | Beam Mesh |
|-----------|-----------|

Mesh information - Details

| | |
|----------------------------------|----------|
| Total Nodes | 1289 |
| Total Elements | 1052 |
| Time to complete mesh(hh:mm:ss): | 00:00:06 |
| Computer name: | |

Model name:Model C18 2-6-17
 Study name:Rollover(-Default<As Machined>-)
 Mesh type:

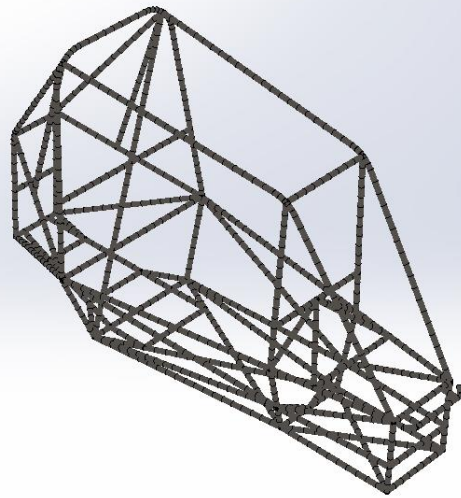

SOLIDWORKS Educational Product. For Instructional Use Only.

Resultant Forces

Reaction forces

| Selection set | Units | Sum X | Sum Y | Sum Z | Resultant |
|---------------|-------|-------|-------------|-------|-----------|
| Entire Model | N | 0 | 0.000366211 | 5000 | 5000 |

Reaction Moments

| Selection set | Units | Sum X | Sum Y | Sum Z | Resultant |
|---------------|-------|---------|----------|---------|-----------|
| Entire Model | N.m | 485.194 | -39.6116 | 25.9144 | 487.497 |

Study Results

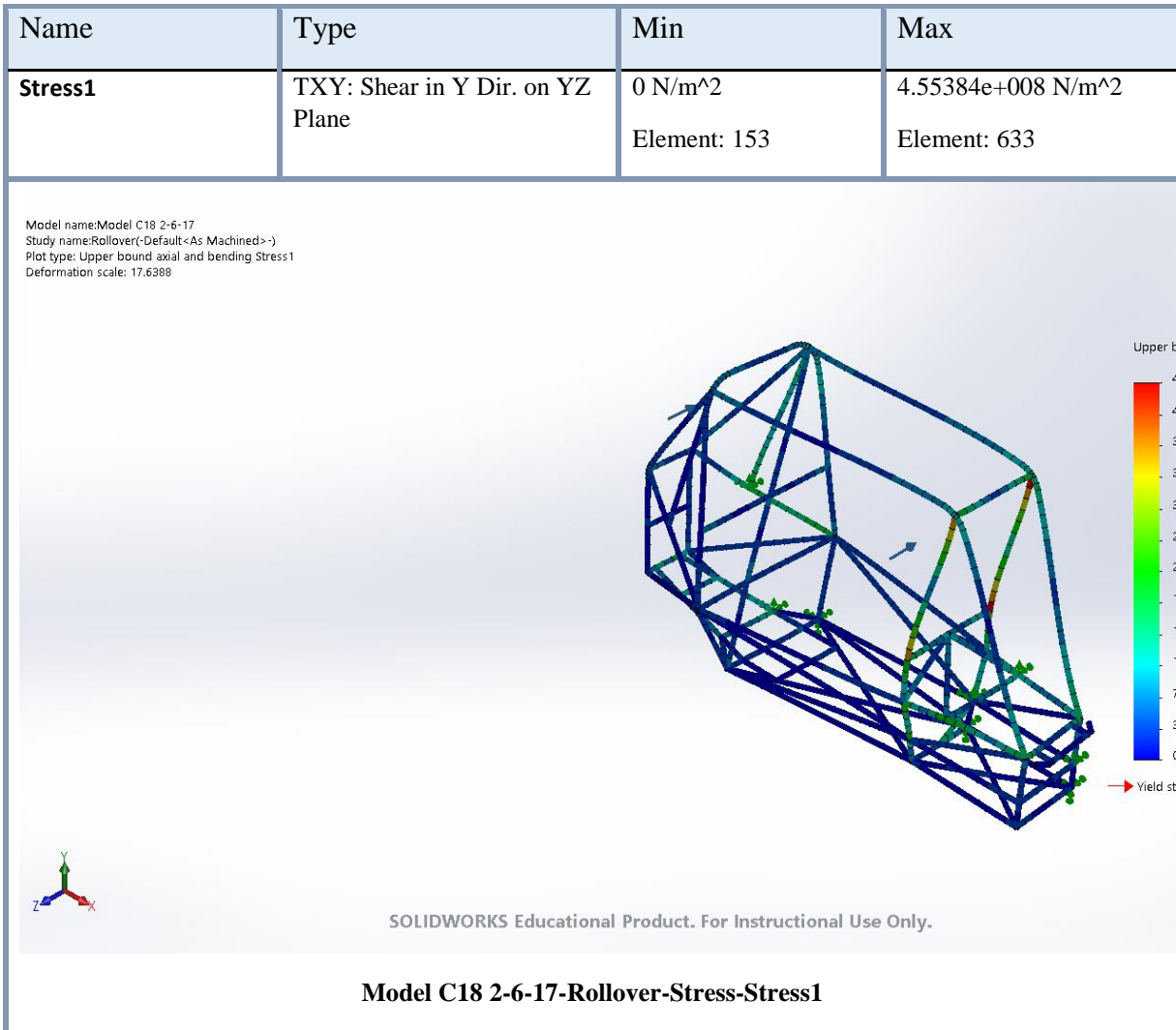

| Name | Type | Min | Max |
|----------------------|------------------------------|------------------|-------------------------|
| Displacement1 | URES: Resultant Displacement | 0 mm Node: 10 | 13.2069 mm Node: 542 |

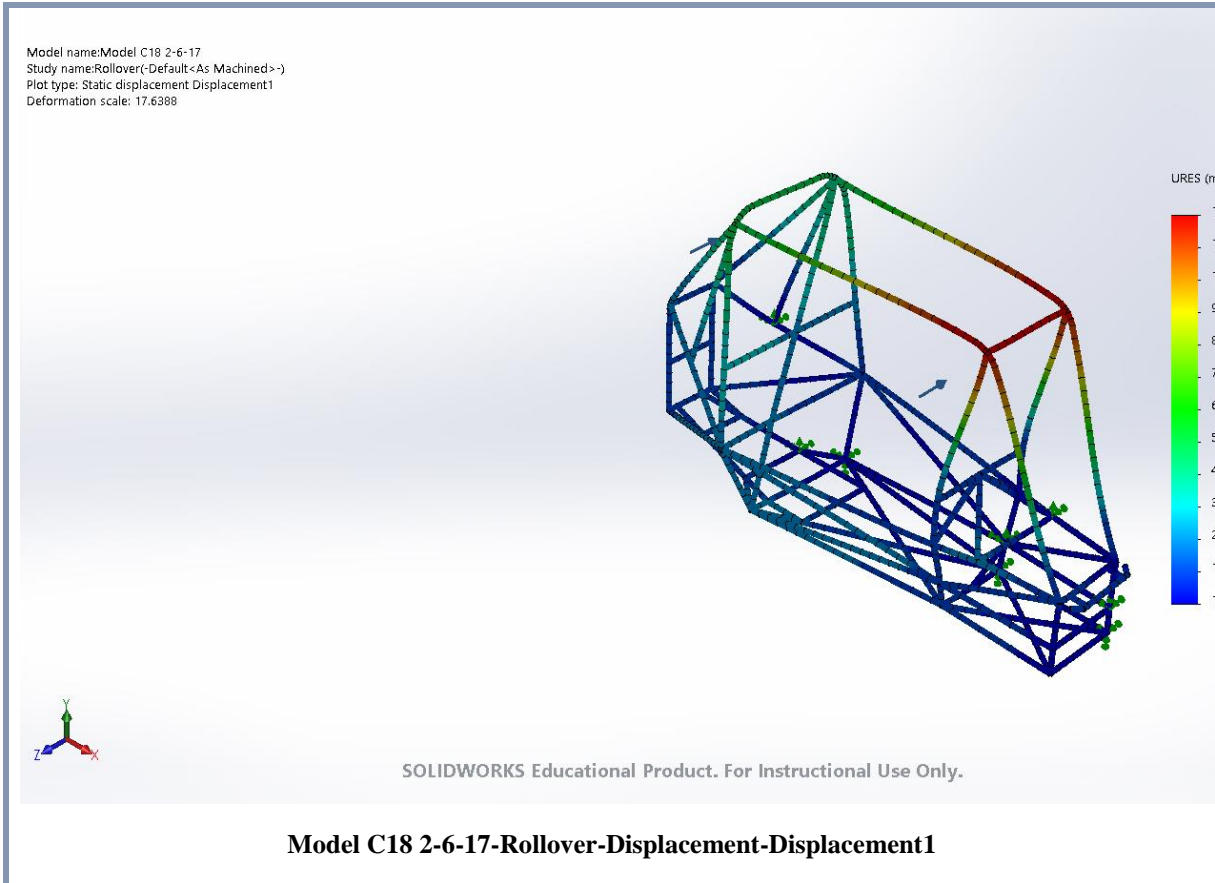

Conclusion

The stress on any one beam never exceeds the yield strength of the material, and so the model is safe in this type of impact.

C5: Drop Impact

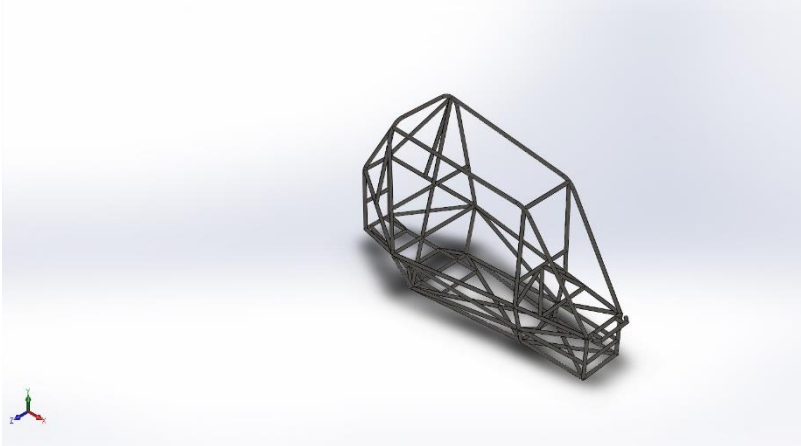

Simulation of Model C18 2-6-17

Date: Tuesday, February 7, 2017

Designer: Heather Selmer

Study name: Drop Impact

Analysis type: Static

Table of Contents

| | |
|---------------------|----|
| Description | 92 |
| Study Properties | 93 |
| Units | 93 |
| Material Properties | 94 |
| Loads and Fixtures | 95 |
| Mesh information | 96 |
| Resultant Forces | 97 |
| Study Results | 98 |
| Conclusion | 99 |

Description

Simulating a drop, which will impact with the force of gravity.

Study Properties

| | |
|------------------------------|---|
| Study name | Drop Impact |
| Analysis type | Static |
| Mesh type | Beam Mesh |
| Solver type | Direct sparse solver |
| Inplane Effect: | Off |
| Soft Spring: | Off |
| Inertial Relief: | Off |
| Incompatible bonding options | Automatic |
| Large displacement | Off |
| Compute free body forces | On |
| Result folder | SOLIDWORKS document (C:\Users\Heather\Documents\WPI\MQP\Solidworks Files\C term models) |

Units

| | |
|---------------------|------------------|
| Unit system: | SI (MKS) |
| Length/Displacement | mm |
| Temperature | Kelvin |
| Angular velocity | Rad/sec |
| Pressure/Stress | N/m ² |

Material Properties

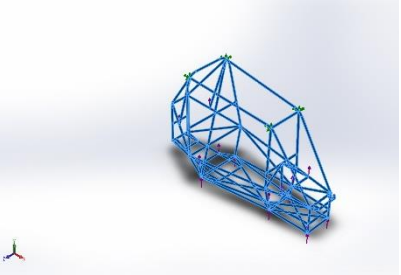
| Model Reference | Properties |
|---|--|
|  | <p>Name: AISI 4130 Steel, normalized at 870C</p> <p>Model type: Linear Elastic Isotropic</p> <p>Default failure criterion: Unknown</p> <p>Yield strength: 4.6e+008 N/m²</p> <p>Tensile strength: 7.31e+008 N/m²</p> <p>Elastic modulus: 2.05e+011 N/m²</p> <p>Poisson's ratio: 0.285</p> <p>Mass density: 7850 kg/m³</p> <p>Shear modulus: 8e+010 N/m²</p> |

Loads and Fixtures

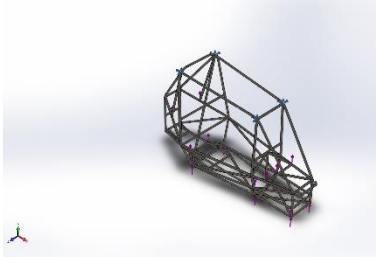
| Fixture name | Fixture Image | Fixture Details |
|----------------|---|--|
| Fixed-1 |  | Entities: 4 Joint(s) Type: Fixed Geometry |

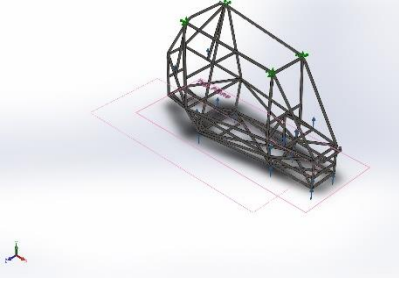
| Load name | Load Image | Load Details |
|----------------|--|--|
| Force-1 |  | Entities: 1 plane(s), 16 Joint(s) Reference: Top Plane Type: Apply force Values: ---, ---, 600 N Moments: ---, ---, --- N.m |

Mesh information

| | |
|-----------|-----------|
| Mesh type | Beam Mesh |
|-----------|-----------|

Mesh information - Details

| | |
|----------------------------------|----------|
| Total Nodes | 1289 |
| Total Elements | 1052 |
| Time to complete mesh(hh:mm:ss): | 00:00:06 |
| Computer name: | |

Model name:Model C18 2-6-17
 Study name:Drop Impact(-Default<As Machined>-)
 Mesh type:

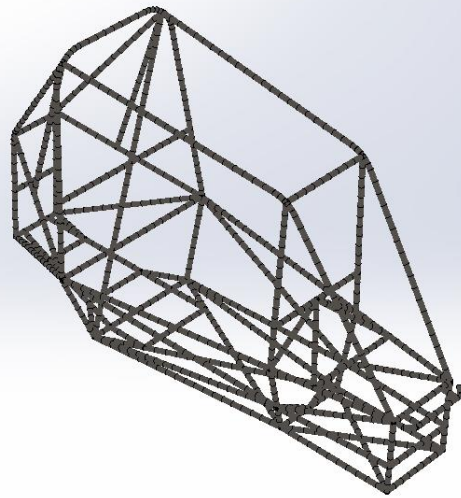

SOLIDWORKS Educational Product. For Instructional Use Only.

Resultant Forces

Reaction forces

| Selection set | Units | Sum X | Sum Y | Sum Z | Resultant |
|---------------|-------|---------------|-------|--------------|-----------|
| Entire Model | N | -6.10352e-005 | -9600 | 7.62939e-006 | 9600 |

Reaction Moments

| Selection set | Units | Sum X | Sum Y | Sum Z | Resultant |
|---------------|-------|----------|----------|----------|-----------|
| Entire Model | N.m | 0.367299 | -1.59298 | -143.215 | 143.225 |

Study Results

| Name | Type | Min | Max |
|----------------|----------------------------------|------------------------------------|---|
| Stress1 | TXY: Shear in Y Dir. on YZ Plane | 0 N/m ² Element: 409 | 1.14821e+008 N/m ² Element: 1 |

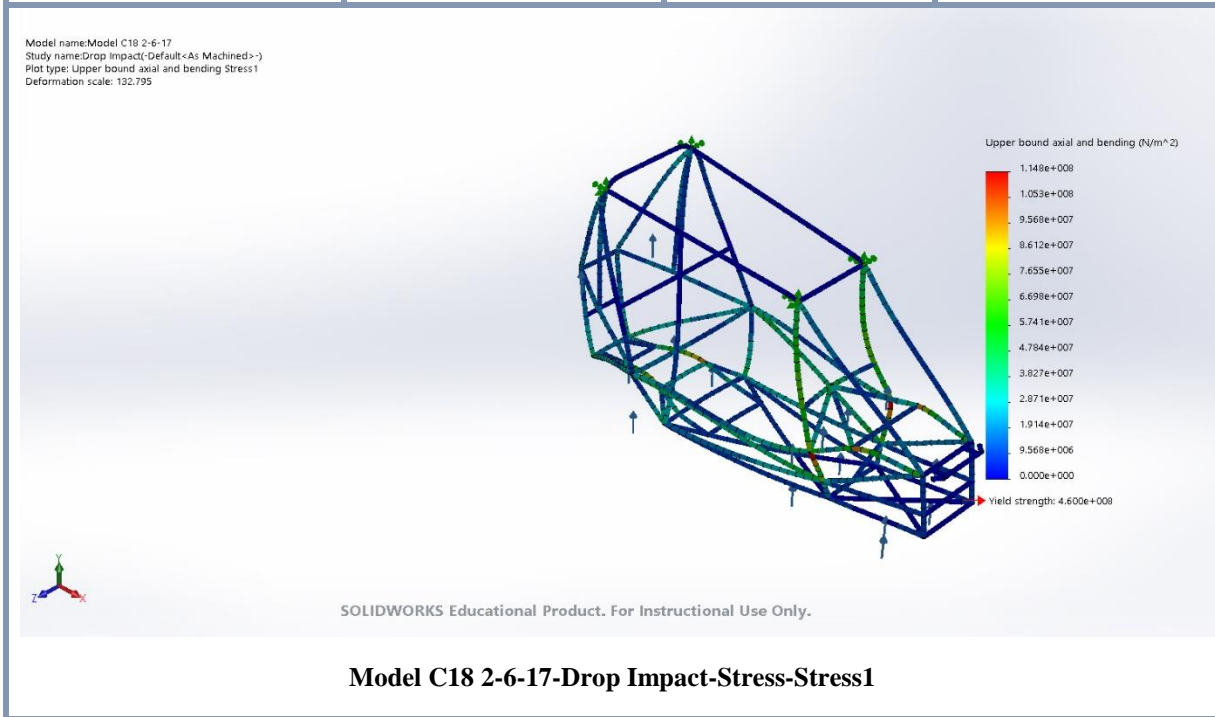

| Name | Type | Min | Max |
|----------------------|------------------------------|-------------------|------------------------|
| Displacement1 | URES: Resultant Displacement | 0 mm Node: 416 | 1.91465 mm Node: 99 |

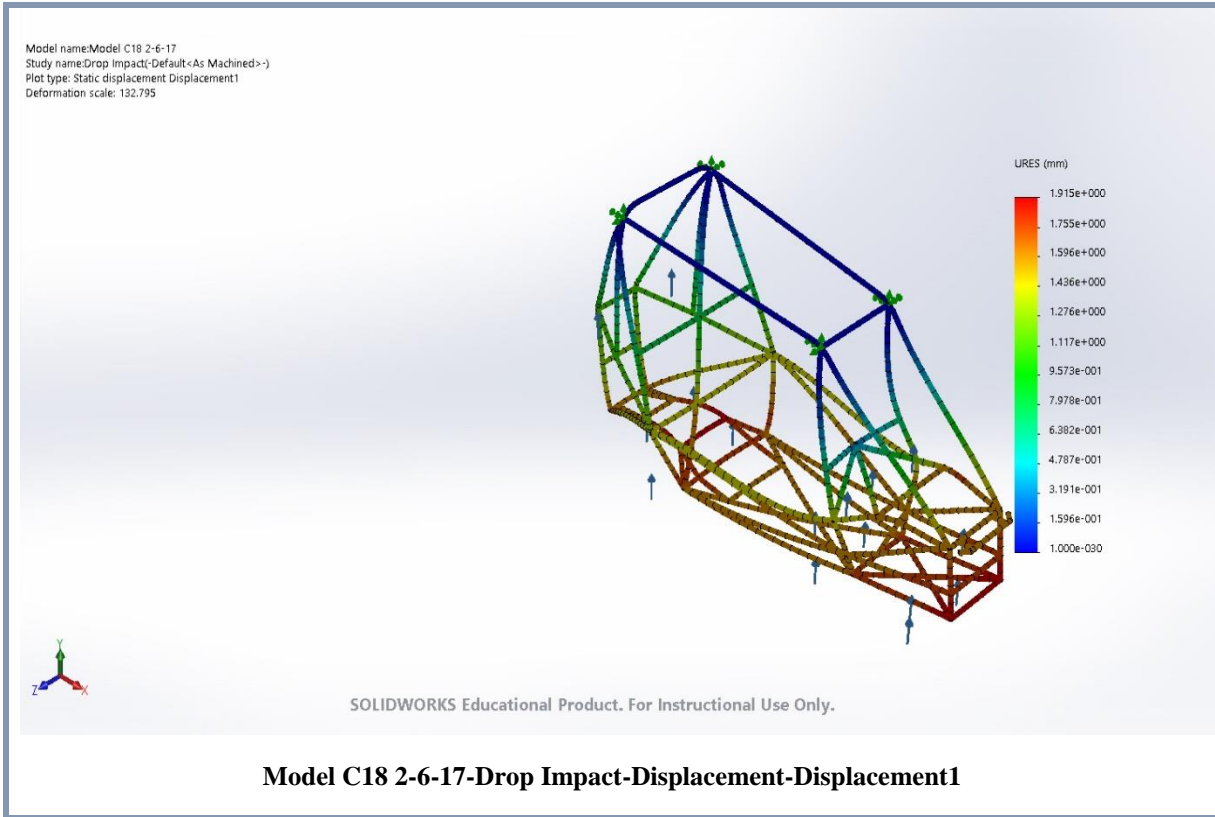

Conclusion

The stress on any one beam never exceeds the yield strength of the material, and so the model is safe in this type of impact.

C6: Side Impact

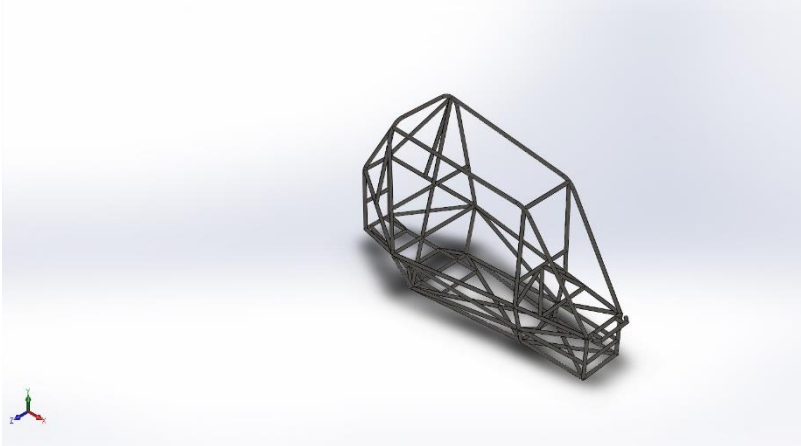

Simulation of Model C18 2-6-17

Date: Tuesday, February 7, 2017

Designer: Heather Selmer

Study name: Side Impact

Analysis type: Static

Table of Contents

| | |
|---------------------|-----|
| Description | 100 |
| Study Properties | 101 |
| Units | 101 |
| Material Properties | 102 |
| Loads and Fixtures | 103 |
| Mesh information | 104 |
| Resultant Forces | 105 |
| Study Results | 106 |
| Conclusion | 107 |

Description

Simulating an impact on the side from another vehicle.

Study Properties

| | |
|------------------------------|---|
| Study name | Side Impact |
| Analysis type | Static |
| Mesh type | Beam Mesh |
| Solver type | Direct sparse solver |
| Inplane Effect: | Off |
| Soft Spring: | Off |
| Inertial Relief: | Off |
| Incompatible bonding options | Automatic |
| Large displacement | Off |
| Compute free body forces | On |
| Result folder | SOLIDWORKS document (C:\Users\Heather\Documents\WPI\MQP\Solidworks Files\C term models) |

Units

| | |
|---------------------|------------------|
| Unit system: | SI (MKS) |
| Length/Displacement | mm |
| Temperature | Kelvin |
| Angular velocity | Rad/sec |
| Pressure/Stress | N/m ² |

Material Properties

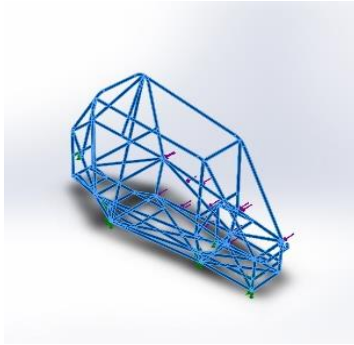
| Model Reference | Properties |
|---|--|
|  | <p>Name: AISI 4130 Steel, normalized at 870C</p> <p>Model type: Linear Elastic Isotropic</p> <p>Default failure criterion: Unknown</p> <p>Yield strength: 4.6e+008 N/m²</p> <p>Tensile strength: 7.31e+008 N/m²</p> <p>Elastic modulus: 2.05e+011 N/m²</p> <p>Poisson's ratio: 0.285</p> <p>Mass density: 7850 kg/m³</p> <p>Shear modulus: 8e+010 N/m²</p> |

Loads and Fixtures

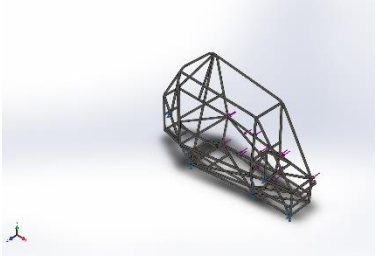
| Fixture name | Fixture Image | Fixture Details |
|----------------|---|--|
| Fixed-1 |  | Entities: 8 Joint(s) Type: Fixed Geometry |

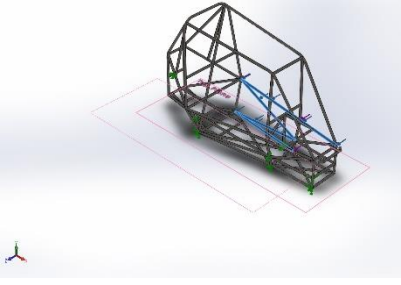
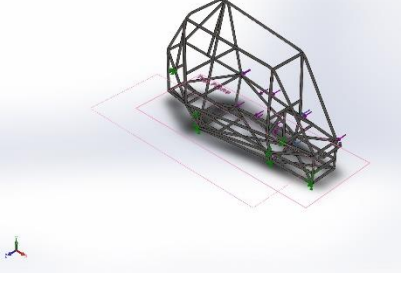
| Load name | Load Image | Load Details |
|----------------|---|---|
| Force-4 |  | Entities: 1 plane(s), 4 Beam (s) Reference: Top Plane Type: Apply force Values: ---, -2000 , --- N Moments: ---, ---, --- N.m |
| Force-5 |  | Entities: 1 plane(s), 5 Joint(s) Reference: Top Plane Type: Apply force Values: ---, -4000 , --- N Moments: ---, ---, --- N.m |

Mesh information

| | |
|-----------|-----------|
| Mesh type | Beam Mesh |
|-----------|-----------|

Mesh information - Details

| | |
|----------------------------------|----------|
| Total Nodes | 1289 |
| Total Elements | 1052 |
| Time to complete mesh(hh:mm:ss): | 00:00:06 |
| Computer name: | |

Model name:Model C18 2-6-17
 Study name:Side Impact-(Default<As Machined>-)
 Mesh type:

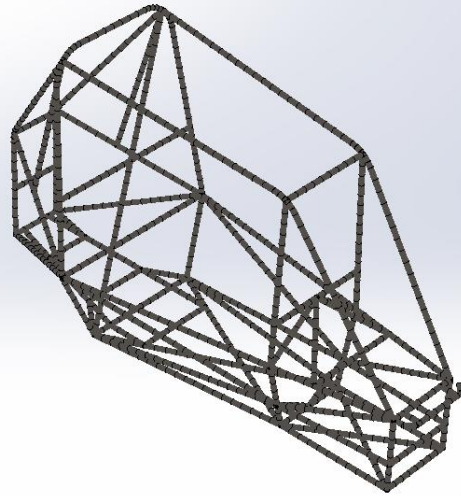

SOLIDWORKS Educational Product. For Instructional Use Only.

Resultant Forces

Reaction forces

| Selection set | Units | Sum X | Sum Y | Sum Z | Resultant |
|---------------|-------|-------------|-------------|--------|-----------|
| Entire Model | N | 0.000854492 | -0.00012207 | -28000 | 28000 |

Reaction Moments

| Selection set | Units | Sum X | Sum Y | Sum Z | Resultant |
|---------------|-------|----------|---------|---------|-----------|
| Entire Model | N.m | -382.216 | 61.0973 | 37.4207 | 388.873 |

Study Results

| Name | Type | Min | Max |
|----------------|----------------------------------|------------------------------------|---|
| Stress1 | TXY: Shear in Y Dir. on YZ Plane | 0 N/m ² Element: 168 | 4.33749e+008 N/m ² Element: 489 |

Model name:Model C18 2-6-17
 Study name:Side Impact(-Default<As Machined>-)
 Plot type: Upper bound axial and bending Stress1

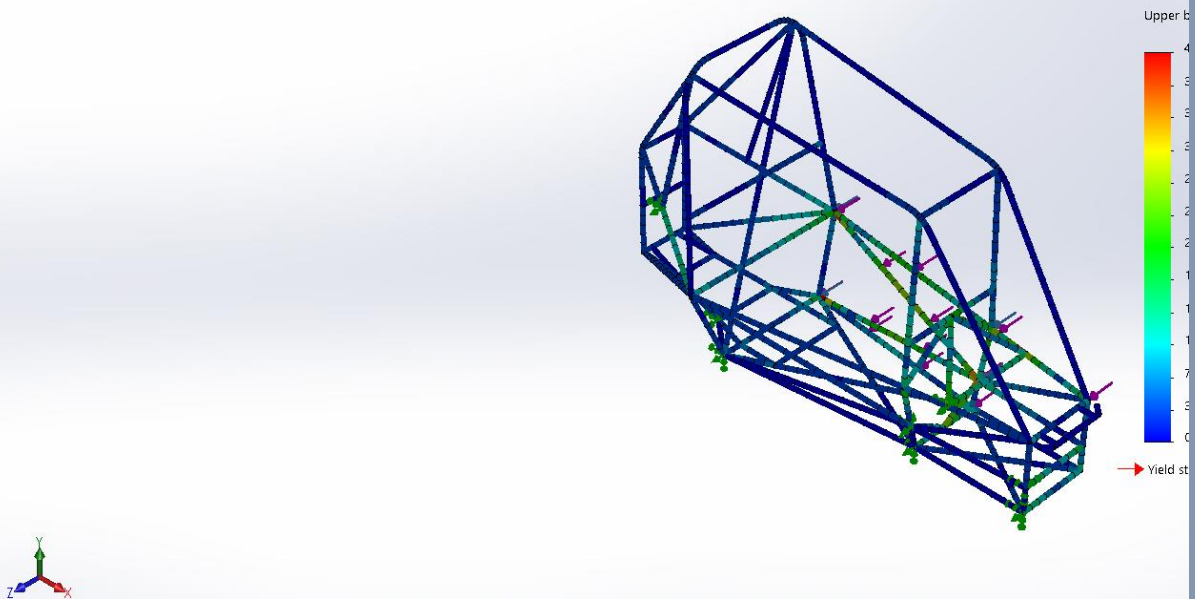

SOLIDWORKS Educational Product. For Instructional Use Only.

Model C18 2-6-17-Side Impact-Stress-Stress1

| Name | Type | Min | Max |
|----------------------|------------------------------|-----------------|-------------------------|
| Displacement1 | URES: Resultant Displacement | 0 mm Node: 9 | 9.96668 mm Node: 328 |

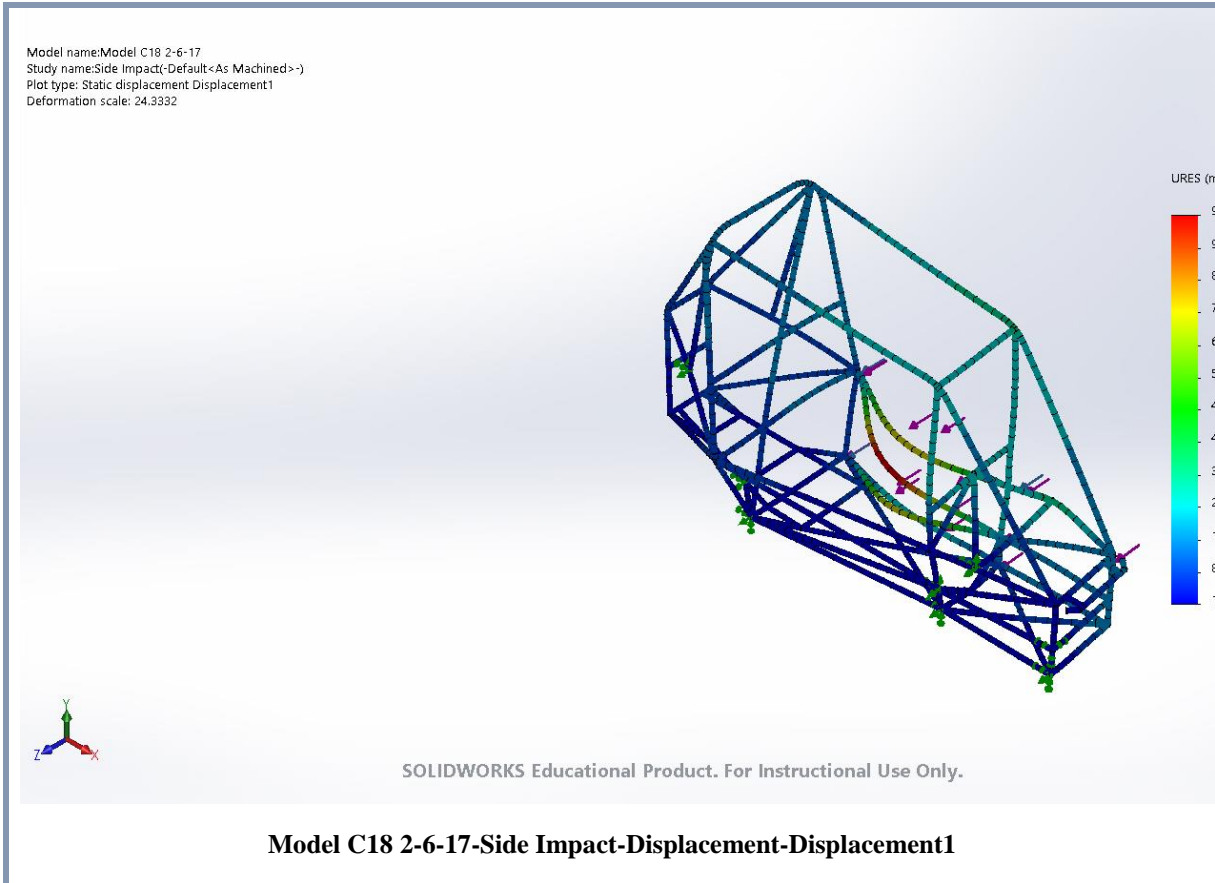

Conclusion

The stress on any one beam never exceeds the yield strength of the material, and so the model is safe in this type of impact.

C7: Top Impact

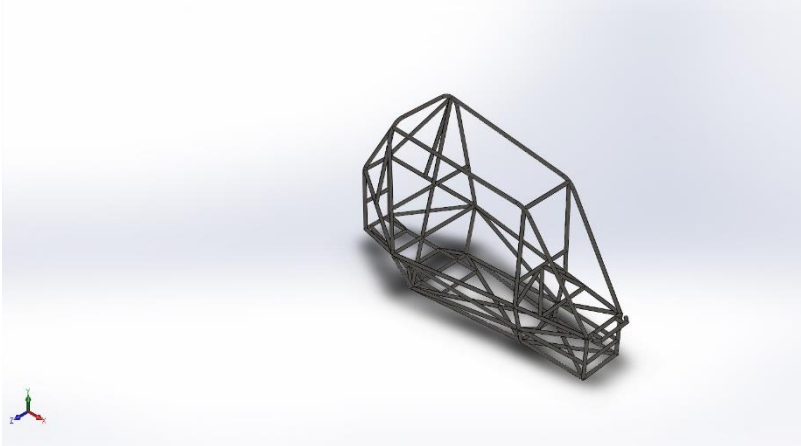

Simulation of Model C18 2-6-17

Date: Tuesday, February 7, 2017

Designer: Heather Selmer

Study name: Top Impact

Analysis type: Static

Table of Contents

| | |
|---------------------|-----|
| Description | 108 |
| Study Properties | 109 |
| Units | 109 |
| Material Properties | 110 |
| Loads and Fixtures | 111 |
| Mesh information | 112 |
| Resultant Forces | 113 |
| Study Results | 114 |
| Conclusion | 115 |

Description

Simulating an impact on top, such as the vehicle lands upside down, or another vehicle lands on top of this one.

Study Properties

| | |
|------------------------------|---|
| Study name | Top Impact |
| Analysis type | Static |
| Mesh type | Beam Mesh |
| Solver type | Direct sparse solver |
| Inplane Effect: | Off |
| Soft Spring: | Off |
| Inertial Relief: | Off |
| Incompatible bonding options | Automatic |
| Large displacement | Off |
| Compute free body forces | On |
| Result folder | SOLIDWORKS document (C:\Users\Heather\Documents\WPI\MQP\Solidworks Files\C term models) |

Units

| | |
|---------------------|------------------|
| Unit system: | SI (MKS) |
| Length/Displacement | mm |
| Temperature | Kelvin |
| Angular velocity | Rad/sec |
| Pressure/Stress | N/m ² |

Material Properties

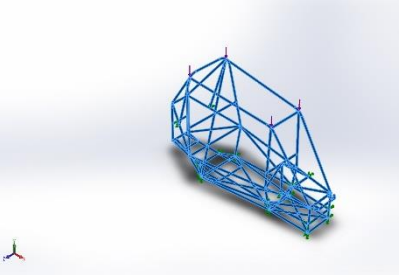
| Model Reference | Properties |
|---|--|
|  | <p>Name: AISI 4130 Steel, normalized at 870C</p> <p>Model type: Linear Elastic Isotropic</p> <p>Default failure criterion: Unknown</p> <p>Yield strength: 4.6e+008 N/m²</p> <p>Tensile strength: 7.31e+008 N/m²</p> <p>Elastic modulus: 2.05e+011 N/m²</p> <p>Poisson's ratio: 0.285</p> <p>Mass density: 7850 kg/m³</p> <p>Shear modulus: 8e+010 N/m²</p> |

Loads and Fixtures

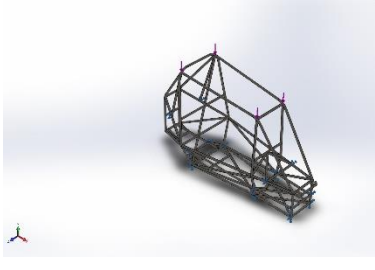
| Fixture name | Fixture Image | Fixture Details |
|----------------|---|---|
| Fixed-1 |  | Entities: 16 Joint(s) Type: Fixed Geometry |

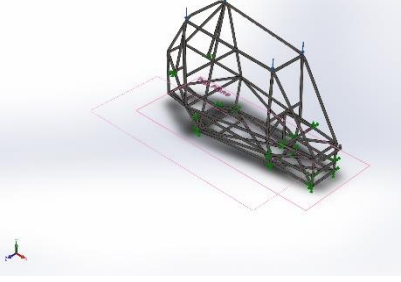
| Load name | Load Image | Load Details |
|----------------|--|---|
| Force-1 |  | Entities: 1 plane(s), 4 Joint(s) Reference: Top Plane Type: Apply force Values: ---, ---, -1750 N Moments: ---, ---, --- N.m |

Mesh information

| | |
|-----------|-----------|
| Mesh type | Beam Mesh |
|-----------|-----------|

Mesh information - Details

| | |
|----------------------------------|----------|
| Total Nodes | 1289 |
| Total Elements | 1052 |
| Time to complete mesh(hh:mm:ss): | 00:00:05 |
| Computer name: | |

Model name:Model C18 2-6-17
 Study name:Top Impact-(Default<As Machined>-)
 Mesh type:

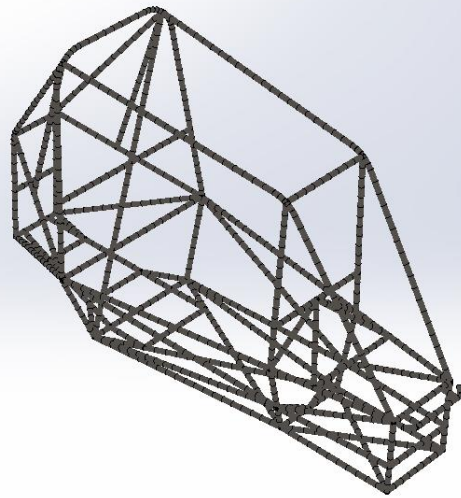

SOLIDWORKS Educational Product. For Instructional Use Only.

Resultant Forces

Reaction forces

| Selection set | Units | Sum X | Sum Y | Sum Z | Resultant |
|---------------|-------|---------------|-------|--------------|-----------|
| Entire Model | N | -3.05176e-005 | 7000 | -3.8147e-005 | 7000 |

Reaction Moments

| Selection set | Units | Sum X | Sum Y | Sum Z | Resultant |
|---------------|-------|----------|----------|----------|-----------|
| Entire Model | N.m | -1.26933 | 0.359218 | -30.9912 | 31.0192 |

Study Results

| Name | Type | Min | Max |
|----------------|----------------------------------|----------------------------------|---|
| Stress1 | TXY: Shear in Y Dir. on YZ Plane | 0 N/m ² Element: 9 | 4.51959e+007 N/m ² Element: 739 |

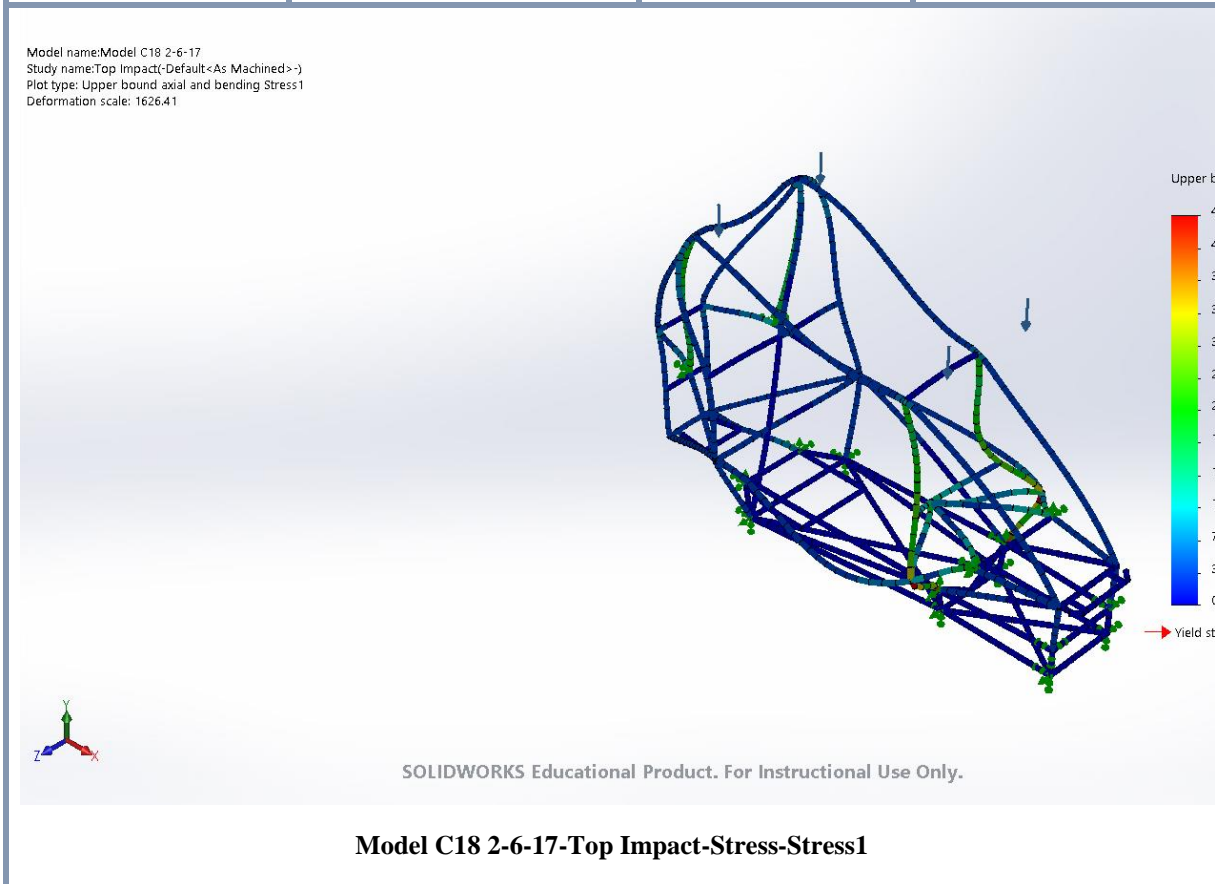

| Name | Type | Min | Max |
|----------------------|------------------------------|-----------------|--------------------------|
| Displacement1 | URES: Resultant Displacement | 0 mm Node: 9 | 0.200992 mm Node: 376 |

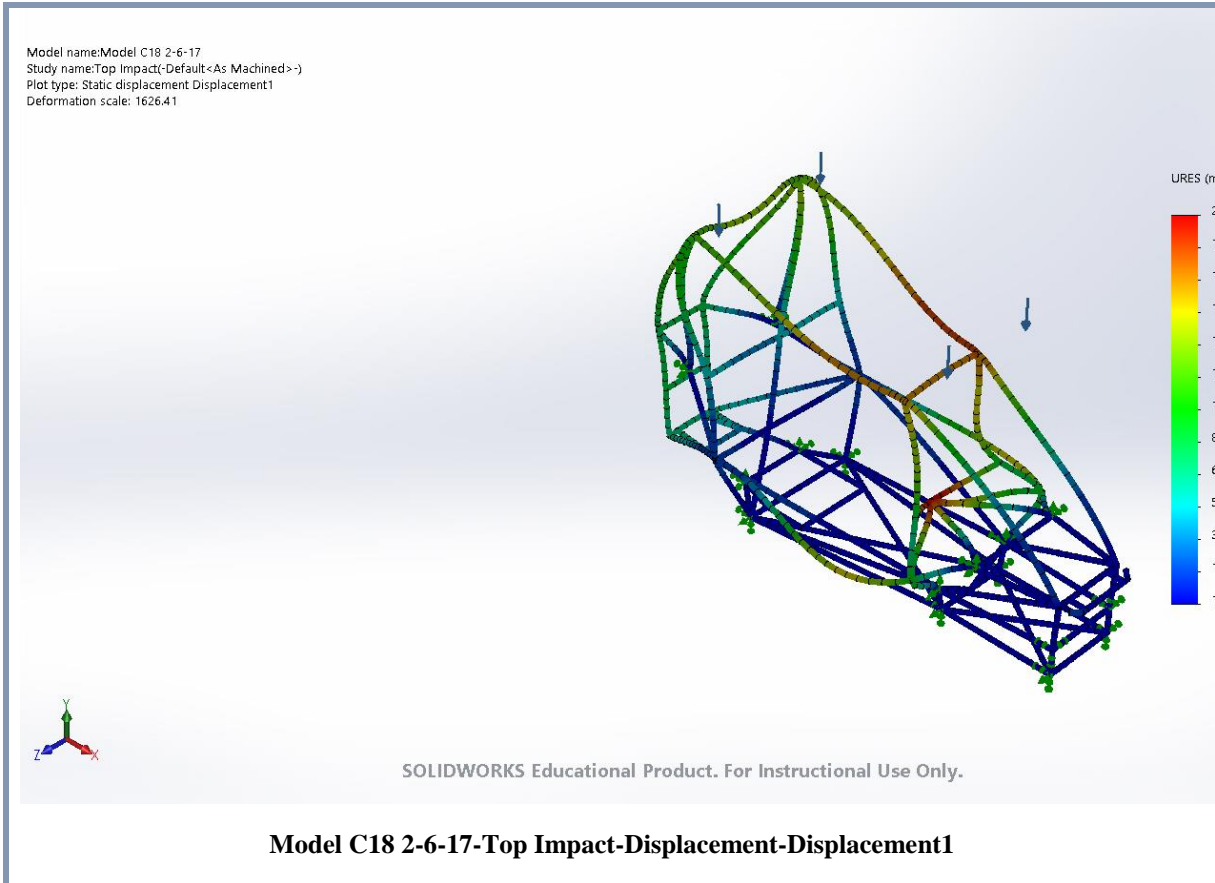

Conclusion

The stress on any one beam never exceeds the yield strength of the material, and so the model is safe in this type of impact.

C8: Driver and Engine Drop

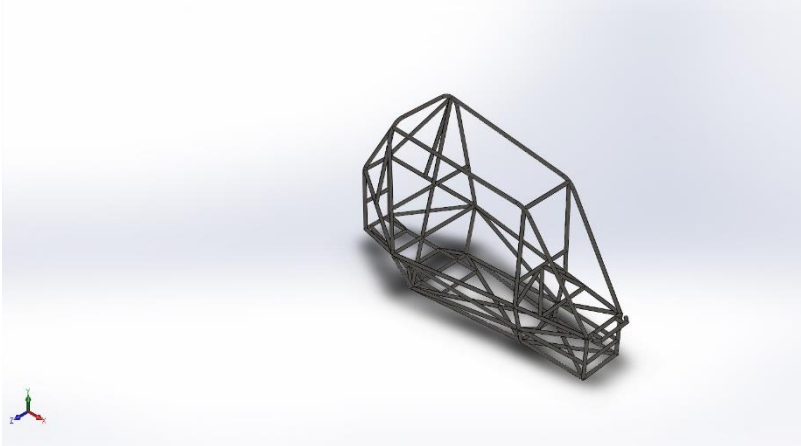

Simulation of Model C18 2-6-17

Date: Tuesday, February 7, 2017

Designer: Heather Selmer

Study name: Driver and Engine Drop

Analysis type: Static

Table of Contents

| | |
|---------------------|-----|
| Description | 116 |
| Study Properties | 117 |
| Units | 117 |
| Material Properties | 118 |
| Loads and Fixtures | 119 |
| Mesh information | 120 |
| Resultant Forces | 121 |
| Study Results | 122 |
| Conclusion | 123 |

Description

Simulating the effect of the driver and engine in a drop when they impact the frame.

Study Properties

| | |
|------------------------------|---|
| Study name | Driver and Engine Drop |
| Analysis type | Static |
| Mesh type | Beam Mesh |
| Solver type | Direct sparse solver |
| Inplane Effect: | Off |
| Soft Spring: | Off |
| Inertial Relief: | Off |
| Incompatible bonding options | Automatic |
| Large displacement | Off |
| Compute free body forces | On |
| Result folder | SOLIDWORKS document (C:\Users\Heather\Documents\WPI\MQP\Solidworks Files\C term models) |

Units

| | |
|---------------------|------------------|
| Unit system: | SI (MKS) |
| Length/Displacement | mm |
| Temperature | Kelvin |
| Angular velocity | Rad/sec |
| Pressure/Stress | N/m ² |

Material Properties

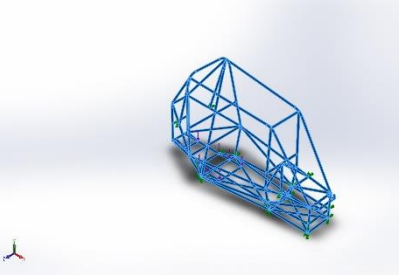
| Model Reference | Properties |
|---|--|
|  | <p>Name: AISI 4130 Steel, normalized at 870C</p> <p>Model type: Linear Elastic Isotropic</p> <p>Default failure criterion: Unknown</p> <p>Yield strength: 4.6e+008 N/m²</p> <p>Tensile strength: 7.31e+008 N/m²</p> <p>Elastic modulus: 2.05e+011 N/m²</p> <p>Poisson's ratio: 0.285</p> <p>Mass density: 7850 kg/m³</p> <p>Shear modulus: 8e+010 N/m²</p> |

Loads and Fixtures

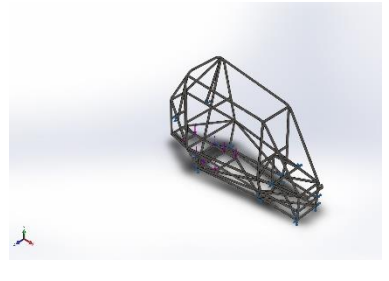
| Fixture name | Fixture Image | Fixture Details |
|----------------|---|---|
| Fixed-1 |  | Entities: 16 Joint(s) Type: Fixed Geometry |

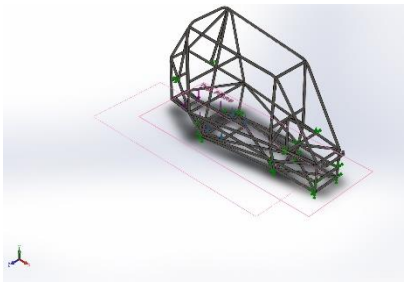
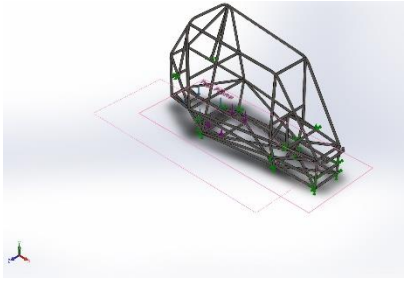
| Load name | Load Image | Load Details |
|----------------|---|--|
| Force-1 |  | Entities: 1 plane(s), 4 Joint(s) Reference: Top Plane Type: Apply force Values: ---, ---, -435 N Moments: ---, ---, --- N.m |
| Force-2 |  | Entities: 1 plane(s), 4 Joint(s) Reference: Top Plane Type: Apply force Values: ---, ---, -225 N Moments: ---, ---, --- N.m |

Mesh information

| | |
|-----------|-----------|
| Mesh type | Beam Mesh |
|-----------|-----------|

Mesh information - Details

| | |
|----------------------------------|----------|
| Total Nodes | 1284 |
| Total Elements | 1047 |
| Time to complete mesh(hh:mm:ss): | 00:00:05 |
| Computer name: | |

Model name:Model C18 2-6-17
 Study name:Driver and Engine Drop(-Default<As Machined>-)
 Mesh type:

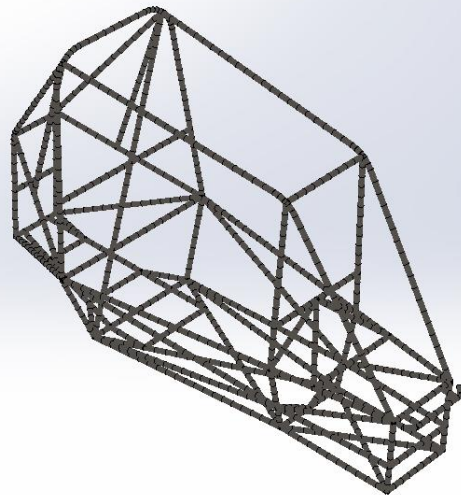

SOLIDWORKS Educational Product. For Instructional Use Only.

Resultant Forces

Reaction forces

| Selection set | Units | Sum X | Sum Y | Sum Z | Resultant |
|---------------|-------|---------------|-------|-------|-----------|
| Entire Model | N | -2.28882e-005 | 2640 | 0 | 2640 |

Reaction Moments

| Selection set | Units | Sum X | Sum Y | Sum Z | Resultant |
|---------------|-------|----------|-----------|---------|-----------|
| Entire Model | N.m | -1.63666 | 0.0160145 | 71.0738 | 71.0927 |

Study Results

| Name | Type | Min | Max |
|----------------|----------------------------------|----------------------------------|--|
| Stress1 | TXY: Shear in Y Dir. on YZ Plane | 0 N/m ² Element: 1 | 1.01712e+008 N/m ² Element: 32 |

Model name: Model C18 2-6-17
 Study name: Driver and Engine Drop(-Default<As Machined>-)
 Plot type: Upper bound axial and bending Stress1
 Deformation scale: 304.557

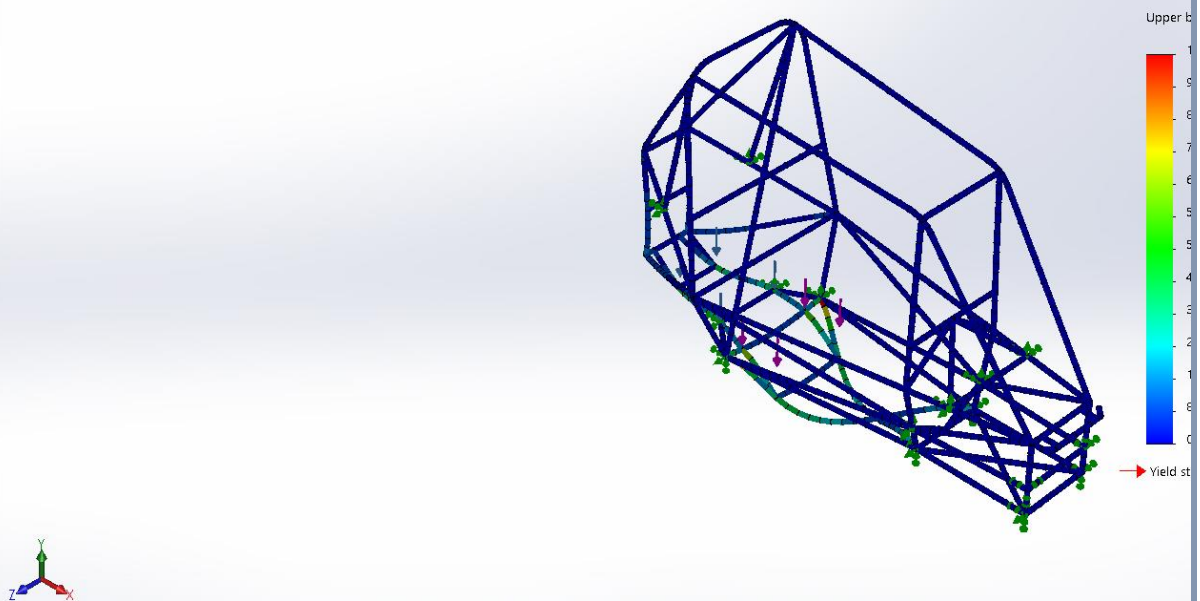

SOLIDWORKS Educational Product. For Instructional Use Only.

Model C18 2-6-17-Driver and Engine Drop-Stress-Stress1

| Name | Type | Min | Max |
|----------------------|------------------------------|-----------------|--------------------------|
| Displacement1 | URES: Resultant Displacement | 0 mm Node: 1 | 0.763333 mm Node: 624 |

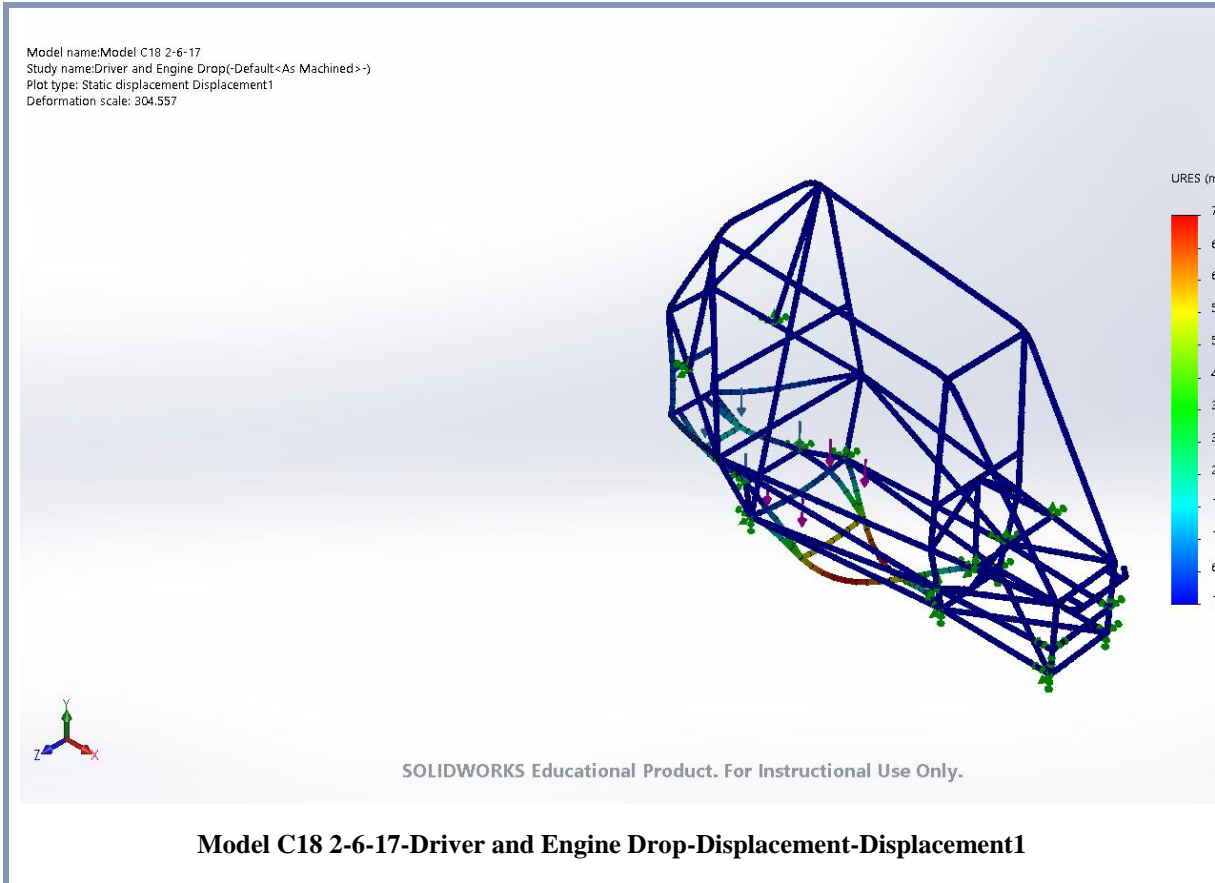

Conclusion

The stress on any one beam never exceeds the yield strength of the material, and so the model is safe in this type of impact.

Works Cited

- [1] "2017 Baja SAE Series Rules." *SAE International*. 21 Nov. 2016. Web. 12 Dec. 2016. https://www.bajasae.net/content/2017_BAJA_Rules_11_21_16.pdf
- [2] "About SAE International." *About - SAE International*. N.p., n.d. Web. 12 Dec. 2016. <http://www.sae.org/about/>
- [3] "Suspension (vehicle)." *Wikipedia*. Wikimedia Foundation, n.d. Web. 8 Dec. 2016. [https://en.wikipedia.org/wiki/Suspension_\(vehicle\)](https://en.wikipedia.org/wiki/Suspension_(vehicle))
- [4] https://web.wpi.edu/Pubs/E-project/Available/E-project-042816-100633/unrestricted/Final_Baja_MQP_Paper.pdf
- [5] https://web.wpi.edu/Pubs/E-project/Available/E-project-043014-170937/unrestricted/Final_Baja_MQP_Report.pdf
- [6] Harris, William. "How Car Suspensions Work." *HowStuffWorks*. N.p., 11 May 2005. Web. 18 Apr. 2017. <http://auto.howstuffworks.com/car-suspension4.htm>
- [7] "Wheel Alignment." *Graham Goode*. Graham Goode Performance & Leisure, n.d. Web. 19 Apr. 2017. <http://shop.grahamgoode.com/wheel-alignment-26419-c.asp>
- [8] Basyoni, Mohamed. "Alignment for car." *LinkedIn SlideShare*. N.p., 14 Mar. 2014. Web. 19 Apr. 2017. <https://www.slideshare.net/MohamedBasyoni/alignment-for-car>
- [9] Cooley, Mark. "Steering Axis Inclination." *Super 7th Heaven*. N.p., n.d. Web. 19 Apr. 2017. <http://www.super7thheaven.co.uk/glossary/steering-axis-inclination/>
- [10] "Suspension Design: Definitions and Effects on Vehicle Behavior." *Car Engineer*. N.p., 18 Apr. 2015. Web. 19 Apr. 2017. <http://www.car-engineer.com/suspension-design-definitions-and-effects-on-vehicle-behavior/>
- [11] "Official Baja SAE Forums." *Official Baja SAE Forums*. SAE International, n.d. Web. 12 Dec. 2016. <http://forums.bajasae.net/>

Figure 4: [http://shop.grahamgoode.com/ekmps/shops/grahamgooder/images/eibach-ez-rear-camber-toe-shims-1.5-1.5-degrees-ford-fieta-02-07-all-models-5.75400k-\[2\]-75105-p.jpg](http://shop.grahamgoode.com/ekmps/shops/grahamgooder/images/eibach-ez-rear-camber-toe-shims-1.5-1.5-degrees-ford-fieta-02-07-all-models-5.75400k-[2]-75105-p.jpg)

Figure 6: <http://i.imgur.com/KCyksGF.png>

Figure 7: <https://image.slidesharecdn.com/steeringsystem-130810025522-phpapp01/95/steering-system-35-638.jpg?cb=1376103420>

Figure 8:

<http://www.rit.edu/clubs/baja/gallery/2016/gallery.phpyear=2016&race=Build%20Season>

Error! Reference source not found.: <http://www.speedwaymotors.com/AFCO-Double-Adjustable-Coilover-Shock-w-Spring-Kit-3-Stroke-99-Comp,24824.html>

: http://www.profendersuspension.com/25-Air-shock_p_15.html