

Authored By:
Daniel Sullivan
Catherine Bannish
Alyssa Fidanza
Nathaniel Peterson
Pokpong Rungthanaphatsophon
Tanit Intaranukulkit
Piebprom Jundee

Environmentally Friendly Roofing Materials in Chiang Mai



2012

Worcester Polytechnic Institute

Chulalongkorn University

The Urban Development
Institute Foundation

ABSTRACT

Chiang Mai has suffered from rapid population growth and inefficient waste management. The Urban Development Institute Foundation has tried to reduce the amount of air pollution by incorporating non-recycled waste into building materials. An attempt at using Tetra Pak for roofing is failing because ultra-violet rays, heat, and moisture are deteriorating the tiles. We researched environmental construction materials, case studies, and local opinions, then constructed prototypes and made recommendations for ecologically friendly roofing. Ultimately, we were able to recommend four different roofing solutions for the UDIF to follow, as well as potential future research groups.

EXECUTIVE SUMMARY

Chiang Mai is a city currently struggling with rapid urbanization and population growth. The strong regional culture attracted many tourists, which contributed to the growth of the city. Due to this, Chiang Mai is suffering from constantly increasing air pollution, particularly due to the inappropriate waste disposal methods in the region. The inability to accommodate for the vast quantities of waste has caused much of the waste to be burned, and further contributed to Chiang Mai's air pollution. This is concerning because mountains surround Chiang Mai, trapping the pollution and thus compounding the air quality issue. The Urban Development Institute Foundation has brought attention to this problem by creating a clay house built of materials that would otherwise be disposed of. Unfortunately, the Tetra Pak roof they created has proved to be defective, and a new design is needed. Our goal was to recommend durable roofing solutions that incorporated waste products in order to reduce the pollution in Chiang Mai.

METHODOLOGY

We began by researching sustainable roofing options from around the world as well as the materials available to us in Chiang Mai. Interviews were conducted with specialists and citizens to determine what materials would be best to use to create a successful roofing structure. Through these interviews, we found that in order for the new roof to be successful, it needed to last over five years, be relatively simple to construct, not further contribute to air pollution, and use waste materials that would otherwise have been burned. The roof would also need to be functional and aesthetically attractive to the community. With these specifications in mind, we decided on five main materials to incorporate into our prototype: clay, cement, vinyl posters, Tetra Pak cartons, and Styrofoam. In order to improve the properties of these materials, we used additives such as wax, oil, and plaster. By using a method of experimentation and modification, we improved upon the flaws found in each prototype, resulting in better designs.

Through researching case studies, we were able to find other solutions that would be plausible for the Foundation's needs. We researched fired clay, compressed earth, organic matter, cement, and plastic bags in an attempt to find other options. Unfortunately, many of the designs we found required processing that released toxins into the air, either by use of chemicals or burning. These designs typically required complex manufacturing, which made them unfit for our recommendation.

Once we had developed a list of potential solutions, we distributed surveys in Chiang Mai to determine public opinion regarding roofing characteristics and concern for the environment. The data acquired was used to determine which qualities were most important for a roof, as well as gauge the potential reception of the recommendation.

FINDINGS AND RECOMMENDATION

While analyzing each potential solution in terms of our objectives, we determined that simply one recommendation was not enough to satisfy the overall goal. The scientific and social aspects of each potential solution varied, and as a result, multiple recommendations were developed to cover multiple contingencies. These recommendations were designed to fit the needs of different types of populations, so that depending on an individual's resources, they may still have a roof that satisfies the environmental goals of this project.

Our main recommendation was a biological garden roof as it most accurately satisfied the goals of the project. This solution not only uses waste materials in its design, but it also reduces the amount of carbon dioxide in the air. Plastic bags can create the roof's waterproofing layer, while Tetra Pak as well as other waste can be mixed into the soil, aiding in the growth of the roof's vegetation. Though we did not test this solution and the lifespan is unknown, we believe it will be a successful and accepted recommendation. However, this solution would not be the best option for the whole community as it is difficult to construct and requires a sturdy structure to build upon. We therefore recommended less difficult roofing options as well.

Our second recommendation is a roofing tile made of Tetra Pak, cement, and sand. The Tetra Pak cartons are shredded and added into the cement mixture to act as a fibrous skeleton. Tiles are then formed in a mold and arranged in a traditional tiling pattern found on other buildings in the area. From the surveys and our site assessment, we found that tiling is a widely used roofing solution, demonstrating that the new tiles could be easily incorporated into the city. This hybrid tile would also help to address the air pollution as it would be using Tetra Pak cartons that would otherwise be incinerated or sit in a landfill. The solution is very durable with an expected life span of about 50 years and can be created either by local residents or a small business. Unfortunately, these tiles utilize cement, which is created in a process that releases a lot of carbon dioxide and are more expensive than other options.

In order to utilize the most waste, we recommend two further solutions. The first is a corrugated sheet made almost entirely of Tetra Pak, created by the GreenRoof™ Company. Despite the process releasing pollution into the air, the product is durable, fireproof, lightweight, and easy to install. This would be a viable option in the Chiang Mai region as many people are currently using corrugated metal for their roofs, so this adjustment would be simple to make. We recommend that the Foundation look more into this company and perhaps help to design a more environmentally friendly manufacturing process.

Our other low cost recommendation is our hybrid corrugated roof made of Tetra Pak and vinyl advertisement strips. The Tetra Pak is layered in a corrugated design with strips of vinyl covering the crests to prevent water leaking and protect the staples from rusting. This solution is inexpensive since it is almost entirely made of waste materials. Moreover, the material is lightweight and can be constructed by the community with relative ease. The problem with this option is that the Tetra Pak's polyethylene layer will still peel due to the UV rays, so we recommend the Foundation continue to look for a solution. In addition, it

Executive Summary

may not last the five years requested by our sponsor, but we believe that it is the best solution if using mostly Tetra Pak and an environmentally-friendly construction method is desired. We further recommend the Foundation observe and analyze our prototype to see how well it lasts compared to their current Tetra Pak roof.

Once we had recommended these four solutions, it became clear to us that environmentally friendly roofing alone was not enough to reduce the pollution in Chiang Mai. Our group determined that it would be in the best interest of the UDIF to recruit two research teams, each to help accomplish future goals of the Foundation. One team would focus mainly on publicizing the Foundation itself, as well as developing ways to educate the citizens of Chiang Mai about the pollution problem. The second group would aim to assess exactly what was producing the majority of the pollution in Chiang Mai so the UDIF could target the exact sources of the pollution. We believe that much more work is needed in order to fulfill all the goals of the Foundation, but are hopeful that our recommendations have paved a path toward sustainable urban development in Chiang Mai.

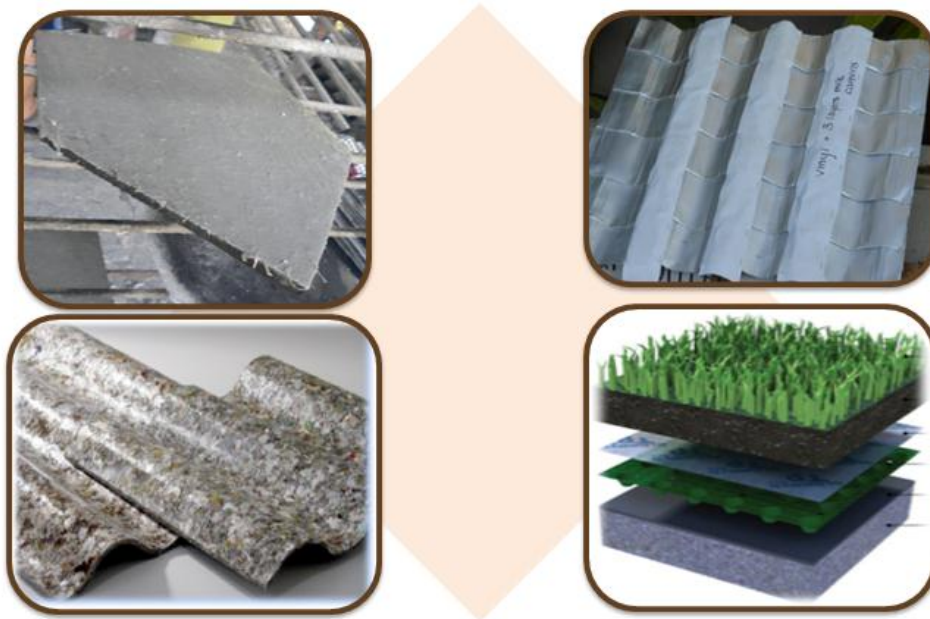

FIGURE 1: FOUR PRIMARY ROOFING RECOMMENDATIONS

ACKNOWLEDGEMENTS

We would like to thank the Urban Development Institute Foundation of Chiang Mai for sponsoring this project. Special thanks go to the Foundation's staff, Niwath Sermma, Chonticha Kawiyok, and Dr. Duongchan Charoenmuang.

We would also like to thank Chulalongkorn University for providing many of the resources necessary to complete this project.

In addition, we would like to thank Samarn Chantakaluk for sharing his expertise with us, and assisting in the creation of the cement prototypes.

It is also important to note that this project incorporates the views and opinions of many people from Chiang Mai, Chulalongkorn University, Worcester Polytechnic Institute, and various areas of Thailand. This includes the ideas of many professionals. Without the help of these people, it would have been impossible to complete the project.

Finally, we want to thank our advisers: Drs. Bland Addison, Rojrit Rojanathanes, and Ingrid Shockey.

Table of Contents

TABLE OF CONTENTS

Abstract.....	i
Executive Summary.....	ii
Methodology.....	ii
Findings and Recommendation	iii
Acknowledgements.....	v
Table of Contents	vi
Table of Figures	ix
Chapter 1: Introduction.....	1
Chapter 2: Literature Review.....	3
Chiang Mai Environment: History, Geography and pollution	3
Urban Development Institute Foundation	5
Weather and Climate	6
Materials	7
Clay.....	7
Cement.....	9
Tetra Pak.....	9
Construction	10
Case Studies of Sustainable roofing.....	12
Tests.....	15
Conclusion	16
Chapter 3: Methodology.....	17
Site Assessment.....	17
In-Depth Interview	17

Table of Contents

Physical Analysis 18

Identifying Unrecycled Materials 18

Developing Roofing Designs 18

Testing and Evaluating Feasibility 19

 Effects on Environment 20

 Testing 20

 Local and Expert Opinions 21

Recommending a Solution 21

Timeline 22

Chapter 4: Findings and Analysis 23

 4.1 Findings 23

 Evaluation of Non-Recycled Waste Materials 26

 Findings Concerning Waste Materials 27

 Clay 28

 Cartons 30

 Vinyl 32

 Hybrid 32

 Findings from Case Study Solutions 33

 Findings from Feasibility Surveys and Interviews 36

 4.2: Analysis of Findings 42

Chapter 5: Recommendations and Conclusions 48

 Roofing Recommendations 48

 Additional Recommendations 51

 Conclusion 52

Bibliography 55

Table of Contents

Appendices 61

 Appendix A: Detailed Testing Procedures 61

 Appendix B: Testing Results..... 62

 Appendix C: Interview Questions..... 63

 Appendix D: Survey 65

 Appendix E: Summary of All Findings 67

 Appendix F: Material Life Cycles..... 68

TABLE OF FIGURES

Figure 1: Four Primary Roofing Recommendations.....	iv
Figure 2: Chiang Mai Province in Thailand	4
Figure 3: Map of Chiang Mai Province	5
Figure 4: Average Monthly Temperature and Rainfall in Chiang Mai	7
Figure 5: Methods for Stabilizing Clay	8
Figure 6: Single Layer Roof Example.....	11
Figure 7: Simple Triangular Frame	12
Figure 8: Green Roof Hut Design.....	13
Figure 9: Transverse Rupture Test	16
Figure 10: Project Timeline.....	22
Figure 11: Peeling Polyethylene on Original Tetra Pak Roof.....	24
Figure 12: Display of Mold Under Original Tetra Pak Roof	25
Figure 13: Hidden Edges Solution made of Tetra Pak	30
Figure 14: Corrugated Tetra Pak Solution	31
Figure 15: Vinyl Advertisement Roofing Solution.....	32
Figure 16: Hybrid Tetra Pak with Vinyl Solution	33
Figure 17: Garden Roof Solution.....	35
Figure 18: Summary of Important Roofing Traits.....	39
Figure 19: Opinions of Roofing Solutions by Location	40
Figure 20: Opinions of Roofing Options by Age Group.....	41
Figure 21: Survey Respondent Demographic by Education.....	42
Figure 22: Summary of Recommendations.....	49

CHAPTER 1: INTRODUCTION

Chiang Mai, a northern Thai city, is full of rich culture and fascinating history. As the former capital of the Lanna Kingdom, Chiang Mai developed earlier than the surrounding cities. Its early development, prime location, and plethora of locally available resources made Chiang Mai the ideal location for a northern trade center. Government incentive for increased trade later brought even more businesses into Chiang Mai, which resulted in an influx of hotels, restaurants, businesses, and people. As Chiang Mai's popularity grew and commerce flourished, the local government pushed for an increase in tourism in order to broaden the business market. These sudden changes to Chiang Mai's classic culture brought new stresses to the city, especially since the local planning and city development was not regulated to keep pace. With the increased population came new problems including improper waste management; waste was often burned instead of being properly disposed of or recycled. Not only did this development and pollution endanger the valuable culture of Chiang Mai, but it also risked the health of the citizens.

The Urban Development Institute Foundation (UDIF) is a non-profit organization that aims to solve problems that are currently burdening Chiang Mai. Centrally located in the heart of this developing city, the organization was originally established by academics of Chiang Mai University in 1990. Its current mission is to improve the lives of Chiang Mai citizens by researching and designing solutions to quell the negative effects of urbanization. While it is still a growing organization, the UDIF is focused on preserving the unique culture of Chiang Mai while allowing the popularity of this city to assist in its own development (Urban Development Institute Foundation, 2002).

One focus area of the UDIF involves eco-friendly, sustainable urban planning by implementing recycled and repurposed waste products into home design. A house made of clay and several waste materials, including Tetra Pak, has been constructed at the site to promote their ideals and serve as a model to citizens and tourists. Not only will this model allow for improved reuse of waste products, but it will help lower the negative impact

Chapter 1: Introduction

Chiang Mai's development has on the environment. However, the UDIF needs a better alternative to their clay house's Tetra Pak roof due to its recent failure.

The new roofing design should be inexpensive, easy to install, use un-recycled waste from the area, and help to counteract the pollution of Chiang Mai. Chosen materials must also be aesthetically acceptable to the public so that citizens will be more willing to use it. Several companies have already developed green building supplies, but the UDIF wants to identify new and innovative materials that can be used for green roofing. A Tetra Pak roof was previously installed on the clay house, but there is room for improvement in both the design and development. The chosen materials need to be structurally sound and waterproof to prevent the leaking which can lead to structural failure, as displayed by the current roof's flaws. After speaking with civil and environmental engineers, we established that the materials need to be water-resistant, durable, insulating, and easy to install. Therefore, our main goal was to recommend durable roofing methods by incorporating waste products in order to reduce the pollution in Chiang Mai.

Not only will this project help to encourage eco-friendly urban development in Chiang Mai, but it will perhaps serve as a model for the rest of the world. The challenges facing Chiang Mai are now commonly shared by most of the urban areas of the world. Unless viable, affordable, and easy solutions to this problem are available, the likelihood of the average person incorporating it into their daily life is very slim. Ultimately, we hope that this project will make a difference in the future of Chiang Mai's development.

CHAPTER 2: LITERATURE REVIEW

This chapter will discuss the background knowledge needed in order to fully understand our project and all it entails. We will discuss the history, environment, geography, and weather of Chiang Mai in order to explain the setting of this project. Later, the history of the sponsoring organization will be explained for the reader to better understand the scope and constraints of the task presented to the project group. Finally, we presented a basic explanation of material properties in order to better understand why each material was considered as a solution.

CHIANG MAI ENVIRONMENT: HISTORY, GEOGRAPHY AND POLLUTION

Once a regional capital, Chiang Mai is a centuries-old city with a long and rich history of settlement, trade, and culture. Over the past hundred years, this city in northern Thailand, shown in Figure 2, has maintained its status as being a very important and sought-after destination. It has in fact recently increased its desirability, especially to businesses (Sittitrai, 1998).



FIGURE 2: CHIANG MAI PROVINCE IN THAILAND

To accommodate for the ever increasing interest in the city, the local authorities in Chiang Mai set up the National Regional Industrial Estate in the mid-1980s, which set aside land for industrial businesses. In 1987, as companies started to look for alternatives to the high production costs in Bangkok, Chiang Mai was the next logical move because of its size, strong education system, commercial industry, and land availability for industrial businesses. The fact that Chiang Mai was a successful city made it so that further businesses only had to be expanded instead of having to be built anew. With the influx of potential business opportunities, the city began to attract more workers from rural towns who had hopes of achieving better financial status (Glassman & Sneddon, 2003). The population increased rapidly before the city was adequately prepared. Previously, the rich culture and environment had been well maintained, however the growing number of outsiders began to degrade both of these.

Chapter 2: Literature Review

One particular problem that the city is facing is air pollution. This northern province is located in a valley completely surrounded by mountain ranges, as shown in Figure 3. Due to this geography, any pollution produced in the city remains in a stagnant cloud over the valley. As the city grows and tourism increases, so does the waste, leading to an increase in burning and the deterioration of the ecosystem (Thomas, 2008).



FIGURE 3: MAP OF CHIANG MAI PROVINCE

URBAN DEVELOPMENT INSTITUTE FOUNDATION

The Urban Development Institute Foundation is a nonprofit organization located in Chiang Mai. Founded by citizens of the city, the organization is concerned with the well-being of Chiang Mai and hopes to aid in its successful development. The foundation was originally established in 1990 as the “Chiang Mai Problem Study Center.” In 2010, the name was changed to the Urban Development Institute Foundation to more adequately reflect the purpose of the Foundation.

The UDIF functions as a learning center for the city of Chiang Mai, informing people about its history, climate change, natural ecosystem, current problems facing the city, as well as potential solutions. Their main concern is the development of a sustainable city. They aspire to have all their visitors understand more about Chiang Mai and its culture in order to help take care of the city. To do this, the UDIF puts on presentations to different groups about the problems of the city and what can be done to help.

Chapter 2: Literature Review

Though education about the city itself is an important part of the UDIF, their main purpose is to help shape the future of Chiang Mai. They hope that by supplying the community with facts and potential solutions to environmental problems, the current environmental degradation will not continue. Part of their educational programming has included demonstrations of what can be done to effectively recycle and reuse. They have created multiple, useful products made from waste, revealing that waste can be used in a creative way instead of simply being incinerated or thrown away (Urban Development Institute Foundation, 2002).

One of the main educational projects created by the UDIF is a house made of clay and a variety of waste materials. Organic materials including teak saw dust and non-recyclable materials such as rubber waste from a sandal factory were mixed with clay and fabric to create bricks for the walls of the house. To further reduce the pollution, the UDIF focused on not utilizing any building methods that would require burning, firing, or factory manufacturing. Just about everything in the house was made with some sort of reused material, thus preventing them from contributing to the waste stream. Each of the materials was selected for their availability, their physical properties, and their inability to be otherwise recycled by the waste management department. Even though the house was constructed with waste materials, the aesthetics were important to ensure it would be attractive enough for people to consider using. The UDIF worked to make the house acceptable to the culture of Chiang Mai, creating an aesthetically pleasing building. Though there have been some minor problems with the physical structure of the house, the Foundation was still successful in creating a “zero waste management concept” (Domingo, 2003). The organization continues to work to make the house even more environmentally friendly by finding new materials to replace the existing traditional building materials such as cement (Urban Development Institute Foundation, 2002).

WEATHER AND CLIMATE

Due to the tropical monsoon climate of Chiang Mai, proper material selection was extremely important. With the fluctuating temperatures and varying amounts of rainfall, building materials must be versatile. As seen in Figure 4, Chiang Mai experiences average

Chapter 2: Literature Review

temperatures between 21.2° and 28.8° Celsius, and rainfall ranging from 6.0 millimeters to about 250 millimeters of rainfall per month. Although extremely uncommon, the north has had hail-storms in the past and Chiang Mai faces threats of hail as well. These differences in weather over the course of a year impose restrictions upon the materials able to be effective in such a climate.

Chiang Mai	<i>Jan</i>	<i>Feb</i>	<i>Mar</i>	<i>Apr</i>	<i>May</i>	<i>Jun</i>	<i>Jul</i>	<i>Aug</i>	<i>Sep</i>	<i>Oct</i>	<i>Nov</i>	<i>Dec</i>	<i>Year</i>
<i>Average Temperature (°C)</i>	21.2	23.4	26.2	28.8	28.7	27.9	27.4	27.1	27	26.3	24.3	21.6	25.9
<i>Average Rainfall (mm)</i>	7.5	6	15	44.9	153.1	135.8	167.1	227	251.3	132	43.9	14.8	1197.1

FIGURE 4: AVERAGE MONTHLY TEMPERATURE AND RAINFALL IN CHIANG MAI

MATERIALS

CLAY

Clay is currently the main component of the sustainable house that the UDIF has constructed. Because the house was to be made mostly of reused materials or waste products, the clay's main purpose was to bind the teak saw dust, fabric, and rubber together in order to build walls for the home (Urban Development Institute Foundation, 2010). Each batch of clay potentially has differing properties depending on its place of origin, therefore the UDIF was careful to use local clay in order to increase the likelihood of replicable results. For instance, clay in one region may have different impurities than others and will cause a varying spectrum of cohesion, grain size, strength, and consistencies (University College of London: Department of Earth Sciences, 2012). However, there are circumstances where different clay types behave in a very similar manner. For instance, most clay must be fired to at least 538° Celsius before it completely hardens. This involves a process in which the clay is first baked at 93° Celsius in order to evaporate most of the water. Once the clay is free of the majority of its water content, the clay is baked at 538° Celsius to completely evaporate all water. This baking at such a high temperature also allows the physical properties of the clay to be altered. Firing allows the porosity of the clay to decrease by reducing the size of gaps between clay particles.

Chapter 2: Literature Review

Consequently, the clay will harden and develop water resistant properties. If clay is not fired at these high temperatures, water molecules do not completely evaporate and the clay's structure is significantly more porous. Therefore, unfired clay is not water resistant and if exposed to water for prolonged periods of time, it will start to erode (Andy Sutton, 2011).

Erosion is a main concern for two reasons. The current leaking roof is allowing water to seep in through the seams in the roofing structure and drip onto the walls of the UDIF's clay house. Because these bricks are built adobe style and were never fired, the water is physically disintegrating the walls that it drips upon. After enough water has dripped on the walls and enough clay erodes, the structure will no longer be safe. Another reason why this erosion may be of concern is if clay roofing tiles were to ever be considered as a roofing material, they would not be able to outlast rainstorms.

	<u>DEFINITION</u>	<u>EXAMPLES</u>
Densification	Create a dense medium, blocking pores & capillary	-Compaction -Adding components - Mixing different soils
Reinforcement	Create an anisotropic network limiting movement	- Straw - Fur - Synthetic fibers
Cementation	Create an inert matrix opposing movement	- Cement - Fly ash
Linkage	Create stable chemical bonds between clay and sand	- Lime
Imperviousness	Surround every earth grain with a waterproof film	- Bitumen - Resins - Various chemicals
Waterproofing	Avoid the water absorption and adsorption by the surface	- Paints - Plaster - Wax

FIGURE 5: METHODS FOR STABILIZING CLAY

In order to stabilize clay and prevent it from failing, the methods shown in Figure 5 can be used (Auroville Earth Institute, 2009).

CEMENT

Cement is a roofing material currently being used in Chiang Mai. Unfortunately, the production requires a large amount of energy and produces a lot of carbon dioxide and heavy metals. According to the research done by Deborah Huntzinger and Thomas Eatmon, “cement production generates an average world carbon emission of 0.81 kilograms of Carbon Dioxide per kilogram cement produced” (Huntzinger & Eatmon, 2006, p. 668). This is the main reason that the UDIF is working to reduce the amount of cement currently being used in their clay house. In addition, most concrete to make cement is taken directly from the earth, which requires energy for mining, digging, transportation, and grinding. This creates either unattractive trenches or mines. Some of the aesthetic issues as well as some of the processing issues can be reduced by using rice husk or similar plant ash; however this requires burning, which creates toxins, and therefore is not an acceptable option (Huntzinger & Eatmon, 2006).

In order to reduce the amount of cement needed, research has been conducted with Styrofoam. It was used as an aggregate in the cement instead of conventional crushed gravel, stone, or river sand (Ahmed, 2008). A study done by universities in Malaysia using Styrofoam pellets between ten and twenty millimeters showed that without any additional processing, Styrofoam reduced the strength of the concrete to below the standard of a structural support. Another study by Korean researchers shows a significant reduction in the tensile strength of this mixture. Because we intended to use these materials in roofing, it may have been feasible as roofing tiles do not need the same strength as bricks. It also may be possible to increase the strength of the tiles with chemical agents like silica-fume or Vinylon. However, by adding these agents, we potentially risk introducing toxins into the air (Byun, 2012).

TETRA PAK

The UDIF has been working with foil-lined cartons, often referred to as Tetra Pak, as a roofing material. These cartons were chosen because even though there are recycling drop off points in Chiang Mai, there is not enough incentive for the citizens to bring them to be

recycled (Chiang Mai Publishing Co., 2004). Cartons are instead burned, releasing chemicals and contributing to the poor air quality that the UDIF is trying to solve (Urban Development Institute Foundation, 2002). Foil and polyethylene layers of the cartons are waterproof and the cardboard layers provide structural support, theoretically providing evidence that they would be suitable for roofing shingles (Tetra Pak, 2012). These cartons also make an inexpensive and readily accessible building material as they are very prevalent beverage containers.

CONSTRUCTION

One of the principle concerns with the UDIF's current roofing system was the amount of leakage. This is understandable considering the immense amount of rainfall in Chiang Mai during their rainy season, which is then interrupted by a long dry season. These opposing extreme weather conditions take a physical toll on the current carton roofing system, which leads to damage significant enough to deteriorate the initial waterproofing characteristics. Therefore, it was essential for the recommended roofing material and construction method to prevent leakage from occurring.

Most Thai residential buildings have very similar construction methods. Homes have a single layer roofing style comprised simply of a wooden frame, horizontal batten, and the top layer of roofing material. This design contrasts vastly with most roofing techniques around the world that use multiple layers of roofing material including insulation, batten, and sheathing (Ohno & Xihui, 2008). Construction of this single layer roofing is shown in Figure 6.



FIGURE 6: SINGLE LAYER ROOF EXAMPLE

With lower quality roofing materials, such as repurposed waste products, one layer of roofing simply does not seem to be enough to withstand the extreme weather to which Chiang Mai is subjected. The current technique calls for cartons as roofing shingles. Once five cartons are stacked to make a shingle, they are stapled directly onto wooden batten before installation. Batten is then installed onto the framing of the roof, and the cartons create a layer of shingles to keep out the elements. This technique lacks an additional water sealant layer that is helpful in preventing leaking (Urban Development Institute Foundation, 2010).

Framing is another aspect of the roofing that could reduce rainwater leakage. Currently, the majority of Thai homes use the simplest framing method, called the “Principal Rafter” technique (Ohno & Xihui, 2008). This is a simple triangular frame that has little reinforcement and uncomplicated construction techniques. It is shown in Figure 7.

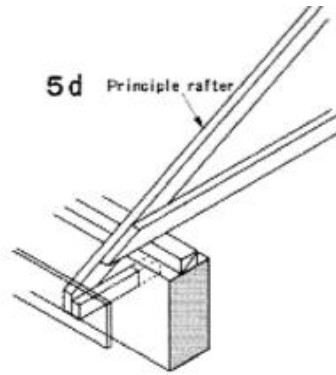

FIGURE 7: SIMPLE TRIANGULAR FRAME

By giving a sturdier structure to the framing of these roofs, we might be able to more successfully install a waterproof layer that will not be damaged by the elements.

Different slopes must also be considered for optimal construction. A steeper slope will deter rainwater faster, but may be less sturdy. Therefore, the angle of the roof will also be dependent on the type of roof decided upon. As we considered each material, we researched the best option for the roof's angle. For instance, a green roof may need to retain more water than a shingled roof made of Tetra Pak cartons, and therefore the slope of the roof must be adjusted accordingly.

CASE STUDIES OF SUSTAINABLE ROOFING

In countries around the world, there have been many innovative roofing ideas to aid in the development of sustainable roofing. One of the methods rising in popularity is to have a “green roof,” where a structure is created to have a garden on the roof. This design has been increasing in popularity in European countries such as Germany, Austria, Switzerland, and the United Kingdom, as well as in the United States. (European Federation of Green Roof Associations, 2010) A hotel in southern Thailand, the Eco-villa, created a hut made entirely out of waste materials with a “green roof.” The technology behind it consists of having a very strong roof with a waterproof membrane and drainage system. As seen in Figure 8, many logs are needed to create this particular design.

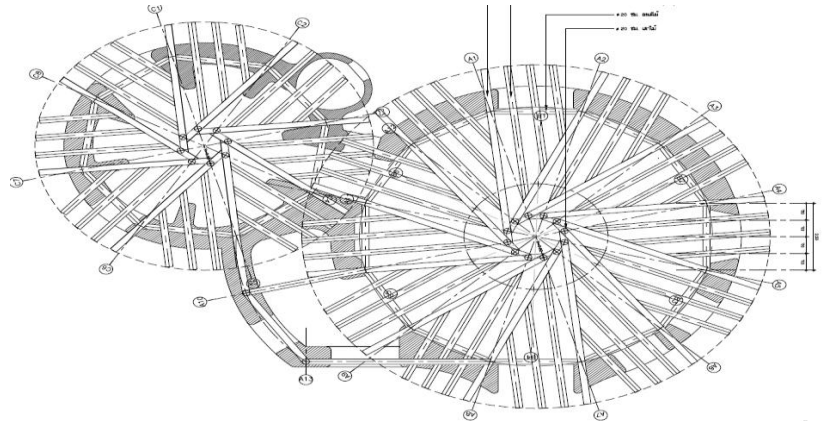

FIGURE 8: GREEN ROOF HUT DESIGN

The final structure allows for crops to be grown on the roof while keeping the inside space cool and dry (Thompson, 2011). Bringing this to the Chiang Mai area may prove to be problematic as it could require a considerable amount of lumber if the beams made from recycled materials prove to be too expensive or too difficult to obtain. Furthermore, it would require a significant change to the building design in order to account for the increased load on the roof.

Rubber roofing tiles have been used as an alternative to both clay tiles and asphalt shingles. These rubber tiles have the benefit of being sturdy, are fairly resistant to fire, and marketed as being very eco-friendly as they are made from recycled rubber and plastic bags. The rubber roofing shingles can also be very aesthetically pleasing, a benefit for the homeowner as well anyone looking at the dwelling. However, in the process of making these shingles, rubber is being heated and pressurized. Rubber is a highly carcinogenic material when burned, so creating the shingles could put the makers and the environment at risk of dangerous exposure. Currently, there are no easy ways to have the tiles brought to or made in Chiang Mai, raising the price of the already expensive product (Roof101.com, 2007).

Another innovative way of building that is being used in other countries has been a modified clay tile. These tiles are extremely light-weight and are made mainly of recycled material. The tiles are currently being used in the western United States. Even though it is a very different climate in the sense that it is very dry in comparison to the heavy rainfall of

Chapter 2: Literature Review

Chiang Mai, they still must deal with the high temperatures and the need to keep a building cool (MonierLifetile, 2011).

There have been new innovations based upon the use of waste-materials in other countries around the world that could have potential as roofing materials for Chiang Mai. Gert de Mulder, a woman in the Netherlands, recently developed a way to make bricks out of plastic grocery bags. By putting a number of bags through high temperatures and pressures, the thin, flexible material can be transformed into hard, durable bricks, dubbed "Recy-Blocks." These blocks are waterproof and are made of 100% recycled material (Kieran, 2010) (Materia Inspiration Centre, 2010). In order for this product to work in Chiang Mai, it would have to be developed into another shape, potentially a design similar to the traditional clay tiles, but having the added benefits of not taking natural resources to produce. Chiang Mai, like other populated areas in Thailand, has an ongoing problem of where to put waste. As plastic, largely consisting of plastic bags, makes up approximately 15% of the composition of waste in Chiang Mai landfills, this solution could potentially satisfy two important goals of the new roof proposal (United Nations Environment Programme, 2007).

Some very organic advances have been made in the building industry. One of the advances involved making clay bricks with banana peels. The properties of the peel helped to fortify the clay and simply make it so that less clay was required for each brick (Wilaipon, 2009). In order to create a roof with this material, a new design may have to be produced so as to create a more stable and structurally sound roof that is not under the threat of collapsing due to any external forces.

Rice husks are another innovative additive that people are using in various materials. By combining rice husks, which have a high content of silica, with high-density polyethylene, scientists have been able to create a bio-composite that is water-resistant, more environmentally friendly than many building materials, and structurally sound. (Yee, 2010) Though this bio-composite has mainly only been tested for structural building parts as opposed to roof tiles, this idea still has the potential to be made into roofing shingles or a stable roofing foundation on which to build.

Chapter 2: Literature Review

Whole communities prove to be highly valuable case studies with regard to sustainable roofing. For the past fifty years, communities such as Findhorn, Scotland have worked to have “zero-carbon” production in the building, powering, and maintaining of their neighborhood. They use different roofing techniques, including green roofs and natural clay tiles. This community has to deal with freezing temperatures and precipitation, and yet has been successful (Findhorn Ecovillage, 2011). Other sustainable villages, such as Auroville, India, have primarily focused on using earth as their main building material. They have used compressed Stabilized Earth Blocks and Stabilized Rammed Earth to make the walls of the houses as well as the domed and vaulted roofs. These roofs were made to be water proof with a mixture of “...soil, sand, cement, lime, alum and juice of a local seed” (Auroville Earth Institute, 2009). One of the main goals of the Auroville construction was to greatly reduce the amount of cement used in the final products, a goal which they achieved by using a clay mixture with only 5% cement. They are able to compress the earth with a relatively simple press to create these structures in an eco-friendly way.

TESTS

The Thai Industrial Standards Institute has been working to ensure that new buildings are built in a safe manner while also preserving the culture of the town. They also promote sustainable development throughout Thailand. In order to ensure that the new construction in Thailand is indeed safe, they have begun to require a number of tests before a building material is approved for sale to consumers. These tests include a water absorption test and a transverse rupture test (Thai Industrial Standards Institute, 2012). The tests and standards provided through the institute gave valuable information about the expected and required levels of performance for any material we used for roofing.

The water absorption test has great significance when concerned with roofing. If a material has high absorptive properties, it has a high chance of causing structural damage if the roof is unable to accommodate for the vastly increased weight. The absorption may also lead to seepage of rainwater into the house. Absorption and subsequent collection of rainwater can easily promote the growth of mold and other fungi, leading to early decomposition of the material. A material for a roof would therefore need to have low absorption or at least

have a protective coat to promote water resistivity (Intertek Plastics Technology Laboratories, 2012).

The Transverse Rupture Test is in place to make sure the roof is able to sustain different types of weather as well as external forces that may be placed upon the roof as shown in Figure 9.

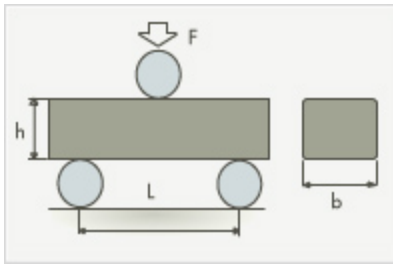

FIGURE 9: TRANSVERSE RUPTURE TEST

This test is necessary since a roof is typically exposed to weather such as rain and wind and occasionally to more extreme weather such as hail. If a roof is unable to sustain a high pressure during the transverse test, which exerts a force in the middle of a roofing tile until breakage, it would not be able to have a very long lifespan (Sandvik Hard Materials, 2008).

CONCLUSION

With this research completed, we were able to determine what information could be useful to the rest of our project. Through our preliminary research about the history, weather, and geography, we determined the limitations of this project and its potential solutions. Our materials research, construction reviews, and case studies gave the knowledge we needed to develop roofing designs. Together, this information helped us formulate the procedures for the rest of the project.

CHAPTER 3: METHODOLOGY

The increasing amount of smog and pollution in Chiang Mai is quickly becoming a major problem for both its citizens and the environment. Recycling or reusing garbage that is otherwise incinerated can easily prevent much of this pollution. Our project targeted this pollution problem by trying to incorporate waste products into a roofing material, which would ultimately encourage sustainable development of Chiang Mai. To accomplish this goal, we outlined the following objectives:

1. Perform a site assessment to identify the scope of the problem
2. Develop roofing designs that incorporate waste materials
3. Discuss with target audience the feasibility of implementation
4. Recommend a solution that best fits the needs of stakeholders

SITE ASSESSMENT

Chiang Mai is currently struggling with the increasing amount of pollution within the city. The UDIF has initiated a clay house project that aims to help reduce this pollution by encouraging sustainable urban development. Because of the roof's recent failure, our group decided to visit the project site in order to develop a new roofing solution and improve the sustainable city development movement they have started. We interviewed the secretary of the UDIF, Dr. Duongchan Charoenmuang, to determine the flaws with the current roof and get a better grasp on the scope of this project. We also conducted a physical analysis of the roof to further understand its deficiencies. Finally, we identified the unrecyclable materials in Chiang Mai that are contributing to the environmental pollution, giving us possible components for potential building materials.

IN-DEPTH INTERVIEW

Before our group was able to start our own analysis, we conducted an in-depth interview with Dr. Duongchan Charoenmuang. The format of this interview was to be a discussion similar to that of a focus group. A list of discussion topics and questions were created to

Chapter 3: Methodology

ensure all necessary information was extracted from the conversation. These can be found in Appendix C.

Our preliminary results were shared with our sponsor to give her a background on what we had already accomplished. We asked for her feedback as well as her expectations. Minutes were taken at the interview by a designated team member and then recorded for us to look back upon if further reference was needed.

PHYSICAL ANALYSIS

To become familiar with the building we were working with as well as the flaws with the current roof, our team conducted a physical analysis. This was done by inspecting the roof from several different angles as well as taking pictures to document the observations made. Flaws in the roofing method were then recorded in order to avoid similar problems in our potential new roofing design.

IDENTIFYING UNRECYCLED MATERIALS

Because there was no specific documentation on the types of waste being disposed of in Chiang Mai, we had to uncover this information on our own. We discussed exactly what waste materials were being incinerated with an expert in the field of Environmental Science at Chulalongkorn University, Dr. Supawin Watcharamul. This same topic was discussed with Dr. Duongchan Charoenmuang, who is a native citizen of Chiang Mai and has been studying waste in the area for several years. In order to expand the range of our project, we also interviewed citizens of a nearby rural province to learn of what waste they burned. All of these discussions were conducted in an open interview manner, and results were recorded for later reference.

DEVELOPING ROOFING DESIGNS

Each newly developed solution was specifically engineered to prevent the flaws of the previous roof design from reoccurring. These failure points, as well as weather hazards such as wind and hail, were all considered in our design process. Dr. Duongchan

Chapter 3: Methodology

Charoenmuang also gave us several specifications to meet, which helped us to better design each potential solution to best fit the needs of the UDIF and their goals.

Before construction started, we performed standardized interviews via email with Chemistry, Material Science, and Civil Engineering specialists from Worcester Polytechnic Institute. These interviews helped us to determine which waste materials might be best suited as construction materials. We then focused our efforts on those materials.

We built several small scale models of potential designs and made qualitative observations in order to preemptively rule a design realistic or not. Once a final design was agreed upon, a larger prototype was built for more in-depth testing.

In order to determine how well each of the materials would perform as a final product, we conducted tests on our several larger prototypes, which will be discussed later in this section. Based upon the results of these tests, more modifications to the prototypes were made to address additional flaws.

When a final, successful prototype was created based upon previous testing, it was set up for the UDIF to monitor long term. These prototypes were designed to function just as they would on the real building, and therefore be representative of long term durability.

TESTING AND EVALUATING FEASIBILITY

In order for this project to be successful, the roofing solution we determined as the best option had to be feasible for people to implement. To fulfill the environmental aspects of this project, we conducted an analysis of the pollution produced by each material. Structural testing was also completed and analyzed to determine which solutions would be most efficient as a roofing material. Finally, opinions of those who would ideally be implementing the roofs were gathered to determine if they would install these solutions on their own homes. These steps are all described in greater detail below.

EFFECTS ON ENVIRONMENT

The life cycle of each potential roofing material was considered when choosing a solution. If a material did significant damage to the environment, it would not be feasible in the sense that it was not parallel with our environmental goals. To determine if each material met appropriate environmental standards, we considered the general carbon footprint of each material's production, distribution, life, and disposal. Because our project required us to reduce the amount of trash incineration occurring, the disposal aspect of the life cycle was of particular interest to us. Therefore, extensive research was performed on the end of each product's life cycle.

TESTING

In order to determine the physical and structural abilities of each prototype, various tests were performed that simulated different conditions a normal roof would face. Each test was performed in a replicable manner, and results were organized for later analysis. Photographic evidence was also gathered since the information garnered was generally more qualitative than quantitative.

Because these materials would ultimately become components of a functioning roof, we needed to mimic several different weather conditions. Our roofing materials had to last through strong winds and heavy rains. Factors such as heat, humidity, and ultra-violet (UV) exposure from the sun would also affect our roof. Certain extreme circumstances, such as fire and hail, were simulated in order to choose the material that would stand up best to these extreme conditions. Hail was simulated by a test called the Transverse Strength Test while fire was tested by a procedure we developed ourselves. We also tested for durability and lifespan of the roof in order to determine if the roof would need constant upkeep and frequent replacements. It was important to test for all of these conditions, as failure of these tests would result in an unsuccessful solution. Exact descriptions of our testing procedures are found in Appendix A.

LOCAL AND EXPERT OPINIONS

A positive opinion from both experts and private citizens about any proposed roofing solution was imperative for the success of this project. This would ensure that the developed roofing methods would actually be implemented and pollution in Chiang Mai reduced. We conducted a round of semi-standardized interviews with a sample of convenience to gauge opinions of Chiang Mai citizens. These interviews helped determine whether or not Chiang Mai citizens approved of our roofing solutions, the aesthetics of the final product, and agreed that our solution had a positive environmental impact. These interviews were mainly conducted in Thai, though some were in English. We developed interview questions in both Thai and English. The answers were documented by audio recorder and on paper to ensure accuracy in the analysis. These interview questions can be found in Appendix C.

We also held a focus group with a chemist, an architect, two builders involved in the construction of the house, as well as the secretary of our sponsor organization. We presented our preliminary findings and testing strategies to them and asked for feedback on what they had seen. This focus group allowed these specialists to converse with each other and build upon ideas. Notes were taken by designated group members who understood both English and Thai in case the discussion changed languages.

In a final evaluation of local opinion, we distributed surveys to a sample of convenience. The purpose of this survey was to see how citizens prioritized physical properties of the building material, its physical appearance, and the incorporation of green materials. Surveys were short to encourage respondents to complete it and prevent time from being a deterrent. Data acquired from this survey helped us to determine the solution most likely to be successfully implemented. Our survey can be seen in Appendix D.

RECOMMENDING A SOLUTION

Our final objective was to recommend a solution to the sponsor. This recommendation was based on our analysis of the various test results, local opinions about the roofing solutions,

Chapter 3: Methodology

the environmental effects of each material, other input from the UDIF, and our own opinions. Since some of the analyses were not quantifiable, we considered the results subjectively to decide a roofing method that would be best for the needs of the UDIF. For instance, if the material performed the best in all of the durability and strength tests, but was the worst for the environment, the material was not chosen.

TIMELINE

Objective	Project Timeline (by Week)								
Date	1	2	3	4	5	6	7	8	9
<i>Merging Ideas</i>	■	■							
<i>Site Assessment</i>	■	■	■						
<i>Developing Roofing Design</i>			■	■	■	■	■		
<i>Project Feasibility</i>						■	■		
<i>Making Recommendation</i>								■	■

FIGURE 10: PROJECT TIMELINE

CHAPTER 4: FINDINGS AND ANALYSIS

In our Methodology Chapter, we gave an overall explanation of how we would approach the problem in order to recommend the best solution. This chapter will express the findings from our methods as well as offer an analysis of the data we gathered.

4.1 FINDINGS

The first step toward completely understanding the problem posed to us was to make an initial analysis of the UDIF's site. We decided that it was necessary to assess the city as well as the roof in order to best understand the problem at hand. An analysis of the roof's physical properties was important in order to confirm the points of failure and to design a new solution that would resolve these flaws. The site assessment allowed us to better understand the people of Chiang Mai. For this project to be successful, it would need the support of the people that it would benefit. Chiang Mai is a city in need, and the assessment of the interests of local residents was essential to the success of this project.

Our first priority was to observe the site of the UDIF. The clay house itself was an impressive structure that was built mostly of waste products, clay, cement, and wood. Overall, the house seemed comfortable to live in and we were surprised at the functionality of the building. However, it was evident that the current attempt at a sustainable roofing method over the bathroom section of the house was ineffective.

We initially observed the roof from the inside of the bathroom structure. The bottom layer of cartons did not seem to have water damage. There was however, an entire section of roof that had failed completely and had been replaced by a large tarp. Additionally, there was a section near the wall in which the gaps between each carton had grown enough that water was able to steadily seep through. This water had started eroding the interior walls of the house, and if this problem is left unaddressed, it would be detrimental to the structure of the home.

Chapter 4: Findings and Analysis

Once we had finished the assessment of the roof from the inside, we used a ladder to view the damage from above. After only one year, the cartons had started to peel, curl, and bend. Ultraviolet radiation was the main cause of the polyethylene peeling off of the cartons. Because of the peeling seen in Figure 11, aesthetic characteristics became a concern. Additionally, implementation of such a roof would be less likely by most people if the appearance of the roof was not appealing. Other weather conditions such as wind, rain, heat, and humidity caused the cartons to bend. This created gaps between the shingles, which allowed water to leak through rather than drain from the roof. The roof of the bathroom only had a slope of twelve degrees, which was simply not enough for water to effectively run off, and contributed to the leaking. Any water that did not leak all of the way through the roof was then trapped, catalyzing the growth of mold and mildew on the cardboard framing structure (Creative Urban Solution Center, 2012). This mold can be seen in Figure 12.



FIGURE 11: PEELING POLYETHYLENE ON ORIGINAL TETRA PAK ROOF



FIGURE 12: DISPLAY OF MOLD UNDER ORIGINAL TETRA PAK ROOF

While this method of roofing was built to be environmentally friendly, we observed that ultimately, it did not solve the issue of Tetra Pak disposal. Instead, it would simply delay the inevitable disposal of the cartons. In addition, since the solution did not last for more than a year it would not even significantly prolong their lifespan.

After this visual assessment, we developed a list of topics and questions to discuss with Dr. Duongchan Charoenmuang, the secretary of our sponsor foundation. Through this discussion, we determined that in order to best fit the goals of the clay house project the materials used should be ones that are made from previously non-recycled waste, and the process of making them into roofing materials should be environmentally friendly. This led us to realize that burning, chemical processing, and all greenhouse gas emissions were to be kept to a minimum. It was also apparent that it would be beneficial if the developed process was simple so future homeowners could construct the roofs themselves. Our hope was that if the project was successful, incinerated waste could be greatly reduced and sustainable living would become much more common in Chiang Mai.

The site assessment allowed our group to gather most of the background knowledge needed in order to start developing roofing materials. From here, we took our next steps toward recommending the best solution possible.

EVALUATION OF NON-RECYCLED WASTE MATERIALS

The opinions of certain experts in the field, our own discoveries, and past discoveries were all essential steps in our development of a successful design recommendation. Each of these findings are described below and were each essential to arriving at our final solutions.

In order to develop a solution incorporating waste materials, we needed to investigate common waste materials available in Chiang Mai. Dr. Supawin Watcharamul, the head of the Environmental Science Department at Chulalongkorn University, was able to provide us with this information. From the interview, we learned about waste management in Chiang Mai. Degradable and non-recyclable waste is sent to the landfills, where it is accessible to those who attempt to salvage any useful non-recycled waste products for resale. Because of this, the specialist mentioned that most materials that would be suitable for roofing would not be available in large quantities. Therefore, if we were to find suitable waste materials to use for construction, we would need to collect them before they reached the landfill.

In addition to consulting the Environmental Science Department, our team decided to seek the advice of several architecture students that were present at the site of the UDIF. When asked about the aesthetic qualities of the current carton roof, they expressed that the looks were secondary in importance to function. Unfortunately, they also stated that the roof must last minimum of five years for them to even consider using the material for their own roofing needs. A professor of the same university shared similar opinions. Our third interview was conducted with teachers from Phrae, a province near Chiang Mai. They confirmed the minimum desired life of five years for a roofing material, unless the roof was extremely easy to install. Therefore, we noticed that five years was a common standard guideline with most people we interviewed. The most common trends mentioned in each interview were functionality, durability, and safety. Surprisingly, price was not as much of a factor, though if a low-cost material could meet these needs, it would most likely be favored.

Through the interviews we were also able to determine that one source of the waste problem was from mismanagement at the city level. Trash is simply collected without being

sorted. Anything of value will be salvaged, and the rest is burned, or left in the landfill. This contributes to the air pollution in Chiang Mai as many things end up being incinerated regardless of how toxic it is when burned. In sum, these interviews offered another perspective in addition to that of our sponsoring organization, about the priorities of the final roofing solution.

FINDINGS CONCERNING WASTE MATERIALS

The above factors led us to investigate three different categories of materials. We separated our research into the classifications of natural raw materials, processed raw materials, and waste materials. Each material had to be locally available and affordable, and therefore shared two common constraints. Some natural materials available to the UDIF were clay, teak sawdust, plant waste and sand. Using grass or teak saw dust would be especially ideal to reduce the pollution from seasonal burning of the local grass and the burning of teak sawdust as a form of waste management. On the other hand, the clay and sand do not naturally cause pollution and thus using these materials would not contribute to our waste management goal. Processed raw materials, along with clay, sand, and vinyl posters, do not necessarily improve the waste or burning problem specifically, but may contribute as a property enhancer to other materials that can. Foil-lined cartons, chip bags, Styrofoam, and plastic bags were all designated as waste materials that fit our specifications. Most are either burned or are thrown in landfills, thus causing pollution. Old vinyl advertisement posters are an exception because of their ability to be resold. The processed raw materials that we evaluated were cement, plaster, waterproof paint, wax and clay. While these do not specifically reduce burning, they are natural materials that are inexpensive and readily available. Our specific discoveries about each individual material are described here in greater detail.

CLAY

Clay was one of the materials suggested by our sponsor, Dr. Duongchan Charoenmuang, because it is abundant, easy to find, and it is a natural product of the earth. On the other hand, the clay itself cannot survive in water and the material is dense. In order to improve its properties, we experimented with clay and several additives.

CLAY WITH CEMENT

In order to improve the water-resistivity of the clay, we combined it with cement. This clay-cement tile had a very long drying period of about two to three days, and underwent a significant amount of shrinkage during this period of time. After drying, the tile contained many cracks all over its surface. Cement and clay together had further potential, therefore as a group we decided to continue experimenting with additional additives to enhance its properties.

Styrene foam was added as an attempt to achieve a more lightweight composition. Through experimentation we noticed that while styrene foam did produce a lighter material, strength was sacrificed as more foam was added. This tile also displayed no water resistive properties and dissolved in water overnight.

Tetra Pak cartons were cut into small strips and added in the mixture of clay and cement. The small strips acted as a fibrous skeleton and increased the strength of the tile. During our strength test, the tile never snapped in half, but rather bent under pressure due to the fiber strength. When the tile dried, there were many carton strands protruding from the edges of the tile. These were very unsightly, and had to be trimmed in order to make a rectangular tile, which would be fit for a standardized tiling pattern. This tile also displayed no water resistant properties as it also dissolved overnight in water.

Vegetable oil was chosen in order to slow the drying rate of the brick and prevent the surface cracking that was occurring. While trying to mix the vegetable oil with the clay and cement, we found that the clay would not stick together. This occurred multiple times with several different ratios of vegetable oil to clay and cement. Once we were finally able to achieve a cohesive mixture, the tile never completely dried, and it gave off an unpleasant

odor. When trying to test the strength of the tile, it completely crumbled when simply picking it up. It did, however, stay together slightly in the water absorption test.

CLAY WITH PLASTER

Plaster was mixed with clay to improve the strength and lighten the tile. During the mixing process, it was discovered that a large amount of water was needed for mixing due to the high absorptivity of the plaster. The clay-plaster tile was quite strong, light-weight, and the surface of the tile was smooth. However, when placed in a water bath, the tiles all failed extremely quickly and completely dissolved overnight.

In order to make the tile weight less, we added Styrofoam to the plaster and clay mixture. While making the mixture, we noticed that an extremely large amount of water was needed because both plaster and Styrofoam absorb water. The Styrofoam was difficult to see when the tile completely dried, making it more aesthetically pleasing, however the tile was extremely brittle.

Sand was added to the mixture to try to add additional binding agents and to increase the strength that which had been reduced by the foam. This tile took a long time to completely dry in the sun and was not strong. In fact, the result was much more brittle than the original foam and clay mixture. It dissolved quickly in water, but was very light-weight.

Small strips of carton were mixed with clay and plaster. The drying duration of this tile was short and the tile was quite strong. However, the strips of carton were once again visible around the edges and needed to be cut in order to meet the regulations of a roofing tile. This tile also completely dissolved in water.

CLAY WITH WAX

Melted wax was mixed with clay powder to help the clay repel water. During the mixing process, we observed that if too little clay was added, the remaining wax would stay separated on the top of the mixture. Moreover, the mixture was hard to combine into a cohesive mix. However this clay tile performed extremely well in the water test and hardly

disintegrated in the water bath overnight. Unfortunately, this tile failed catastrophically when exposed to heat because the wax completely melted.

CARTONS

The hidden edge solution, shown in Figure 13, was mainly designed to address the curling flaw that was extremely detrimental in the original carton roof. The stapling of the bottom half of the carton prevented the edges from being able to curl up and water from getting underneath. There were no areas on this roof that would curl up over time, and there were very few exposed staples. After exposing this roof to simulated heavy rain at many different angles, we found that the downward lip of each carton collected water. Effectively, the bottom edge of each carton was lined with a very small amount of water that did not evaporate even after a day of drying. Since the bottom edges of each carton went beneath another carton, we found that the lip would wick water underneath the neighboring layers. The underside of this and other carton solutions was also not particularly aesthetically pleasing since they obviously had the appearance of old juice boxes.

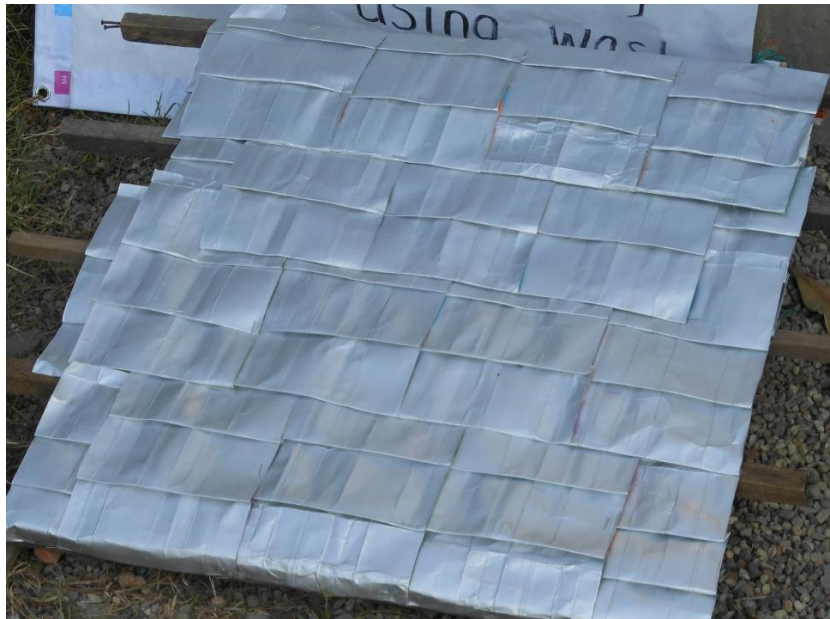

FIGURE 13: HIDDEN EDGES SOLUTION MADE OF TETRA PAK

A ribbed solution was designed to control the flow of water away from the weakest points of the carton roof's construction. In order to do this, we made a pointed edge that would

Chapter 4: Findings and Analysis

cause water to run into a lower sloped curve and allow water to run in a steady stream down the roof and away from any seams. Making this model was extremely labor intensive and required an inordinate amount of staples. We finished half of the first layer on the model in a period of three hours. We determined that the entire roof would take an extremely long time and discontinued construction; therefore, no picture is available.

After discussing with students from Far Eastern University in Thailand, who were visiting the UDIF as volunteers, the solution in Figure 14 was developed using the cartons. The edges were tucked away as in the hidden edges model, but the gaps that had previously caused a problem were also hidden. Water flow was directed in the wells of the corrugated roofing to direct the water away from the staples, seams, and other weak points of the roof. One flaw was that water still seemed to get trapped on the ridges of the cartons, and it still ran over the corrugated crests.



FIGURE 14: CORRUGATED TETRA PAK SOLUTION

The wax-seamed solution is an idea which surfaced as a solution to the curling and leaking of the edges of the cartons. Wax was placed between the seams of two cartons to create a water tight seal between the two cartons. After only hours in the sun, the wax was extremely malleable and began slowly run down the carton, though it did not fully melt. After a day of exposure, we found that the wax had become brittle and any slight separation at the seam of the cartons resulted in a gap in the wax.

VINYL

The vinyl solution shown in Figure 15 was developed to address the peeling flaw in the current roofing method. It was created to have the same corrugated pattern as the corrugated carton roofing solution to direct water flow. We found that, despite the corrugated-style troughs, a fair amount of water ended up passing over the support ridges and over the exposed staples. The vinyl solution was extremely durable and did not allow water to permeate the roof. To achieve this durability, four staggered layers of vinyl were needed. Since the vinyl sheets were so large, very little manual labor was required in order to apply this roofing to the frame. This solution did, however, require an extremely large number of vinyl posters.



FIGURE 15: VINYL ADVERTISEMENT ROOFING SOLUTION

HYBRID

In addition to the single-material options, we considered a hybrid solution that would incorporate the positive qualities of several solutions. We combined the hidden edge concept of the first solution, the corrugated pattern of the second solution, and the water resistivity of the vinyl to develop a carton-vinyl hybrid solution is shown in Figure 16.



FIGURE 16: HYBRID TETRA PAK WITH VINYL SOLUTION

Vinyl allowed the water to be more easily guided into the troughs of the corrugations, and hid the seams that may cause leakage effectively. Due to the corrugated nature of this design, there were no exposed staples in the troughs. The staples holding the vinyl down were exposed, but did not pose a problem.

FINDINGS FROM CASE STUDY SOLUTIONS

After creating our own physical models, we researched case studies of other roofing options that may potentially fulfill the needs of a quality roofing material. Many of the case studies, including compressed earth and Recy-Blocks, were dismissed from our list of possible solutions due to the machinery and processing needed and a lack of overall benefits. Therefore, we focused our efforts mainly three possible solutions: fired clay, a green botanical roof, and a roofing system created by the Tetra Pak Company. Our findings on these items were based on research rather than experimentation, because we did not have enough time or equipment for complex the complex testing procedures required.

FIRED CLAY

Fired clay has been used as a roofing material in several areas of the world for thousands of years. For instance, Mexican adobe houses date back for centuries and have roofs built of fired clay. These tiles last upwards of seventy-five years at a time and do not sustain much damage from weather concerns such as hail, rain, and wind. In order to produce clay tile roofing, the mold is first filled with the clay roofing material, thus being shaped correctly into its tile form. The tile is then baked at a low temperature to remove the majority of the water in order to prevent damage during firing. After the baking is complete, the clay is put in a kiln for twenty-four hours. This process causes air pollution; however other waste is prevented due to the longevity of the roofing material (Discovery Channel, 2010).

ORGANIC GREEN ROOF (GARDEN ROOF)

A green roof made of biomaterials such as plants, soil, and a bio-frame is another option that would not only provide a waterproof, insulating, and stable roof structure, but would simultaneously be able to remove toxins from the air. Plants, through photosynthesis, are able to remove carbon dioxide from the air and produce oxygen as a byproduct. They can also remove harmful gases from the air depending on the plants chosen. A study done by an association titled “Green Roofs for Healthy Cities,” also demonstrated the ability of a green roof to help reduce the effects of global warming. It was found that “even minimal green roof implementation, approximately 6% of roof space, could reduce urban summer temperatures by one to 2° Celsius” (Oberndorfer, et al., 2007).

Research on green roofing proved that it might be a method to reduce the amount of material burned in landfills each year. Typically, soil is the main medium in which to grow different plants, however, the addition of certain organic waste products can actually improve the quality of the growing medium. It may also prolong the life of associated waterproofing membranes, reducing associated waste. Using this type of waste material in the green roofing solution will not only keep it from getting burned or sent to a landfill, but will make the roof produce healthier plants.

Chapter 4: Findings and Analysis

In order to build this roof, several layers are needed, and a slope of less than thirty degrees is necessary. The following diagram shows some of the necessary layers required for a green roof (Hren, 2011).

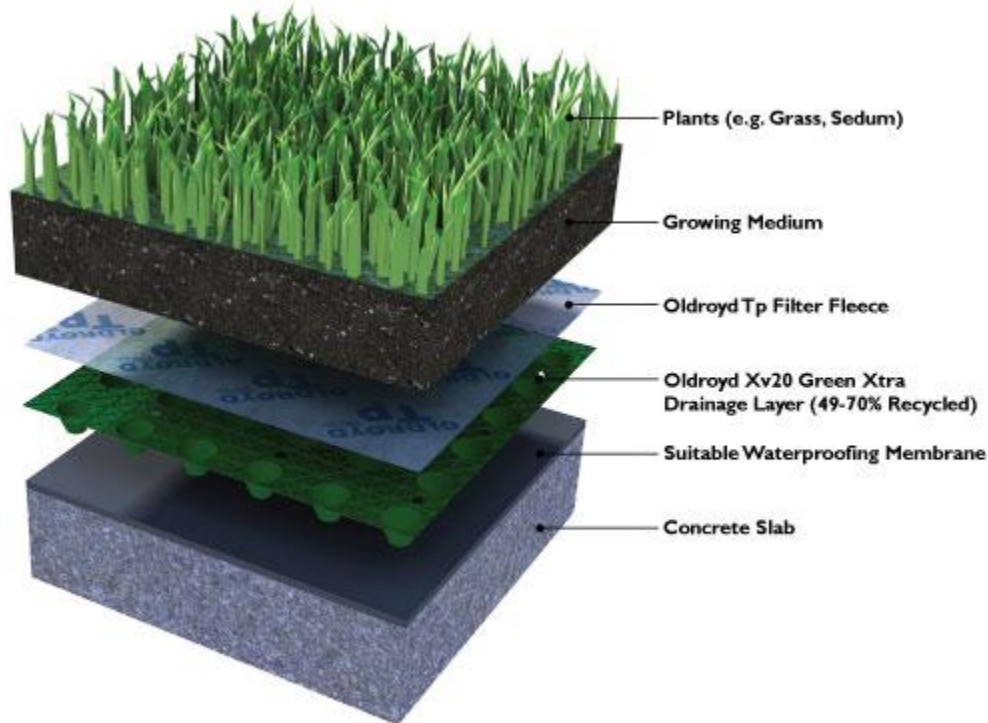

FIGURE 17: GARDEN ROOF SOLUTION

A stable structure for the bottom layer is required in order to give the green roof stability. A waterproof layer must be added on top of the structural layer to ensure that if excess water that cannot be absorbed by the soil reaches the structural layer, it will not leak through the roof. If insulation is required, it should be placed on top of this waterproofing layer next. The drainage and storage layer would collect most of the water that falls through the soil. If the slope of the roof is over fifteen degrees, a lattice framework will be required to prevent the growing medium from draining off of the roof when it rains. Filter fabric and a growing medium are placed on top of this to allow the plants to grow. Finally, the plants are the topmost layer.

MANUFACTURED GREENROOF™

During our research, we also discovered the GreenRoof™ project. This project, headed by Tetra Pak (Thailand) Co. Ltd., is a recycling campaign that provides roofs for people in need, especially those affected by the recent flooding. The GreenRoof™ is made of recycled Tetra Pak, which has been separated into plastic, cardboard, and foil by soaking it in a liquid medium. Plastic and aluminum layers are then separated, shredded, and compressed into the shape of large roofing tiles. This foundation not only encourages recycling, but also discourages pollution by reducing the waste being incinerated or put in landfills (GreenRoof, 2012).

A similar solution to the GreenRoof™ that our group found was the TerraCycle Company. The differences between these groups include the materials being recycled and how it is done. TerraCycle takes various packaging materials, such as snack bags and candy wrappers, and either recycles, up-cycles, or manufactures them. In order to get people to recycle these materials, TerraCycle will give monetary incentive to non-profit organizations for every chip bag sent to them. Their goal is to “eliminate the idea of waste by creating collection and solution systems for anything that today must be sent to a landfill” (TerraCycle, 2012) which, if implemented in Chiang Mai, could eliminate the pollution caused by non-organic waste being burned.

FINDINGS FROM FEASIBILITY SURVEYS AND INTERVIEWS

In order for us to determine the feasibility of implementation, we developed an interview and survey procedure that would give us data to determine the best social solution. Our interviews focused on gathering specific information about certain materials, while the surveys focused on the general public and their willingness to implement sustainable solutions. This would allow us to analyze each solution on a social level and reach a conclusion that would be best for the community of Chiang Mai.

We conducted interviews via email with Material Science professors from Worcester Polytechnic Institute in order to gain additional information about each possible roofing material. When asked about the cartons, Material Science professor, Dr. Crysanth

Chapter 4: Findings and Analysis

Demetry, explained that even though she had never worked with cartons she knew, “it will be very difficult to make them weather-resistant for a five year period.” She also explained that unfired clay would not be possible, as “it would become extremely heavy when waterlogged and may slump” (personal communication, 16 January, 2012).

We personally interviewed an experienced potter, Joy Friedman, to further explore the properties of clay. She emphasized that in order for clay to be a viable option, it had to be fired considering “under-fired clay will remain porous. You must have the clay mature so the particles can come together and become dense” (personal communication, 13 January, 2012). When we inquired about using a lower temperature to fire the clay, she mentioned terracotta clay, which is fired at 1000° Celsius, but it is not as strong. She informed us about electric kilns which could be used to fire the tiles without producing many toxins. In order to make a tile more light weight, she suggested using vermiculite instead of anything organic or paper-based. Vermiculite would be light and able to withstand the firing process whereas the other add-ins, such as grasses or other fiber could catch fire.

It was also necessary to evaluate the feasibility of implementing the different roofing materials. To aid us with this assessment, we interviewed architecture students from Kasetsart University. They said that having a roof made of cement is relatively expensive compared to other roofing options. However, they were not sure if the time and energy needed to create a carton roof would be worth it. When asked about sustainable roofing for Chiang Mai, they believed we were targeting the wrong audience, as many people here would consider environmental awareness as something strictly for the wealthy. After sharing some preliminary ideas, they suggested that we try change this stereotypical belief by allowing the roofing material to be affordable and accessible to not only Chiang Mai, but around the world.

To get a sense of who the project would benefit, we conducted interviews with a small number of elementary school teachers from the rural province Phrae. We learned that the waste problem is different in their hometown. Garbage is collected and taken away to a landfill, so they are not suffering from over pollution in their village. However, they burn the grasses from their fields. Changing the roofs would not work for them as they explained

Chapter 4: Findings and Analysis

that most people in the village are farmers and would not have the time to build a roof made of waste products that they would have to carefully separate. The grass roofs are quick, easy, and effective for them. However, they did say that they believed the younger generation might be interested in helping fight global warming and would not desire a traditional looking roof as strongly as the older generation does. The teachers believed that if a roof could be made with very low-cost materials, it might be worth using even if it needed replacement every five years. However, because the grass they use now is a free resource, utilizing any material that would cost them money would not make sense.

Our team then conducted surveys that allowed us to assess the priorities of Chiang Mai citizens concerning different materials to roof their home. This survey can be found in Appendix D. Once our survey samples were completed, the responses were organized in an excel spreadsheet to more easily visualize and understand the acquired data. Not only did we analyze the data as a whole, we also focused our observations into three main demographic categories: age, place of residence, and education level. By analyzing our data based on different demographics, trends that may have gone otherwise unnoticed were uncovered.

We asked our respondents to rate the importance of nine different roofing material characteristics. Overall, we noticed durability, longevity, and weatherproof properties were the most important qualities to our sample population. Material costs averaged at third, which was followed very closely by the incorporation of green materials. Labor related characteristics such as cost of labor, ease of construction, self-installation, and installation time were the least important to our respondents. Therefore, this left aesthetics in the middle as a moderate concern. This information is displayed in Figure 18.

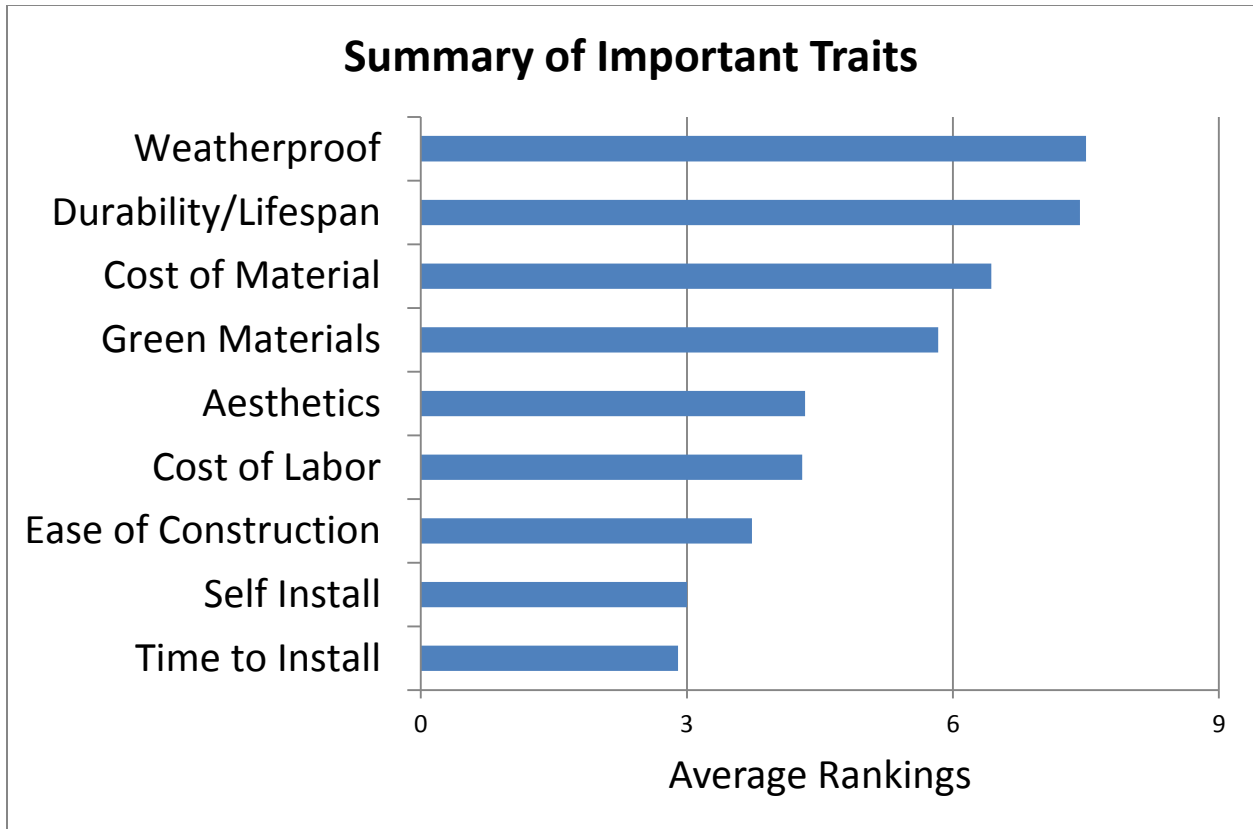

FIGURE 18: SUMMARY OF IMPORTANT ROOFING TRAITS

Our participants then responded to visual models of several different prototypes that we ourselves created, and other potential solutions from around the world. We asked each respondent to rate the samples based on visual appearance on a scale of one to five, with one being the worst. In general, the sample ranked the garden roof and the traditional clay roofing tiles as the most attractive roofing style. This was closely followed by the GreenRoof™ sample that was created by the Tetra Pak Company. Vinyl was the least attractive option to our respondents and received very negative feedback. The Tetra Pak roofing method that the UDIF had initiated received neutral ratings, but still seemed to be generally acceptable.

We then examined the results based on where respondents' home were located. Surveys were received from those who lived in rural, suburban, and urban areas to determine whether roofing preferences were different in each area. This analysis was performed to allow our group to better cater our recommendations to the widest spectrum of Chiang Mai

citizens. If needed, we could make multiple recommendations based on the target audience installing the environmentally friendly roof. The data conveyed that self-installation was less important in urban areas than rural areas, but overall it was not of high importance amongst people anywhere. Installation time was most important to the urban people, but they were less concerned with durability than rural and suburban people. Overall, the location of the person filling out the survey did not make a significant difference in their opinions, as the data showed the same trends. One interesting observation was that the respondents that lived in rural areas did not find thatch roofs aesthetically pleasing. This information is organized in Figure 19.

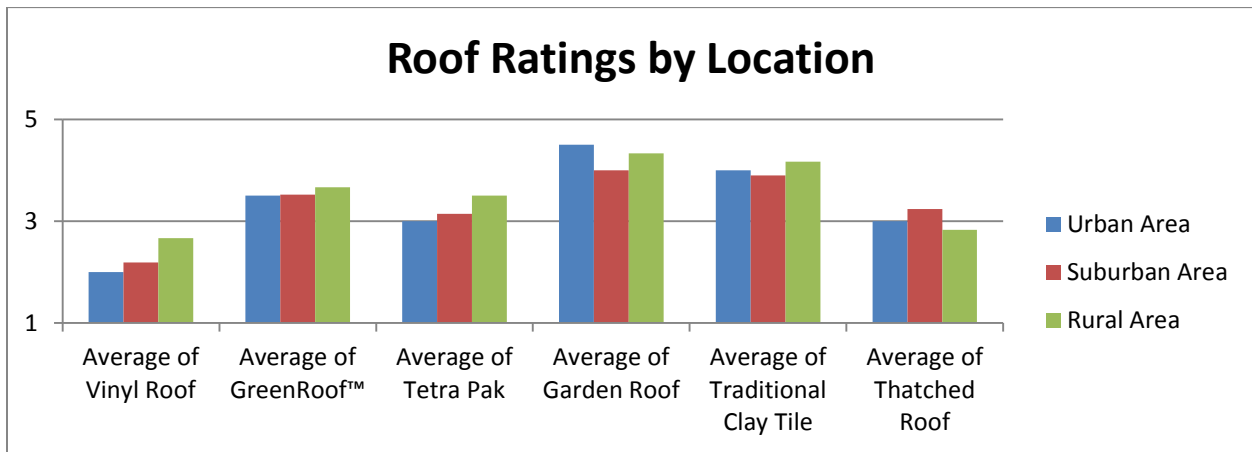

FIGURE 19: OPINIONS OF ROOFING SOLUTIONS BY LOCATION

Next, we performed an analysis with our data organized by age group, as seen in Figure 20. This organization method was utilized to provide us with age groups that were most willing to implement environmentally friendly roofing. Another advantage of this procedure was that this data would tell us which age groups were environmentally conscious. As we analyzed the data, it was evident that those who were between the ages of thirty and fifty found the GreenRoof™ to be the most attractive out of all the samples provided to them. The garden roof as well as the thatched roof closely followed the GreenRoof™ as most visually pleasing. Traditional roofing looks, such as the clay roof, the thatched roof, and the garden roof, were preferred amongst the fifty and over age group. Young adults however thought that the GreenRoof™, clay roof, and the garden roof were the best looking roofs. All of the age groups rated the Tetra Pak roof neutrally once again. In

addition, each age group rated essential roofing qualities such as lifespan, cost, and weatherproof properties as the most important roofing characteristics. Surprisingly, our data showed that every group rated incorporation of green materials and aesthetics equally, directly following the essential roofing properties.

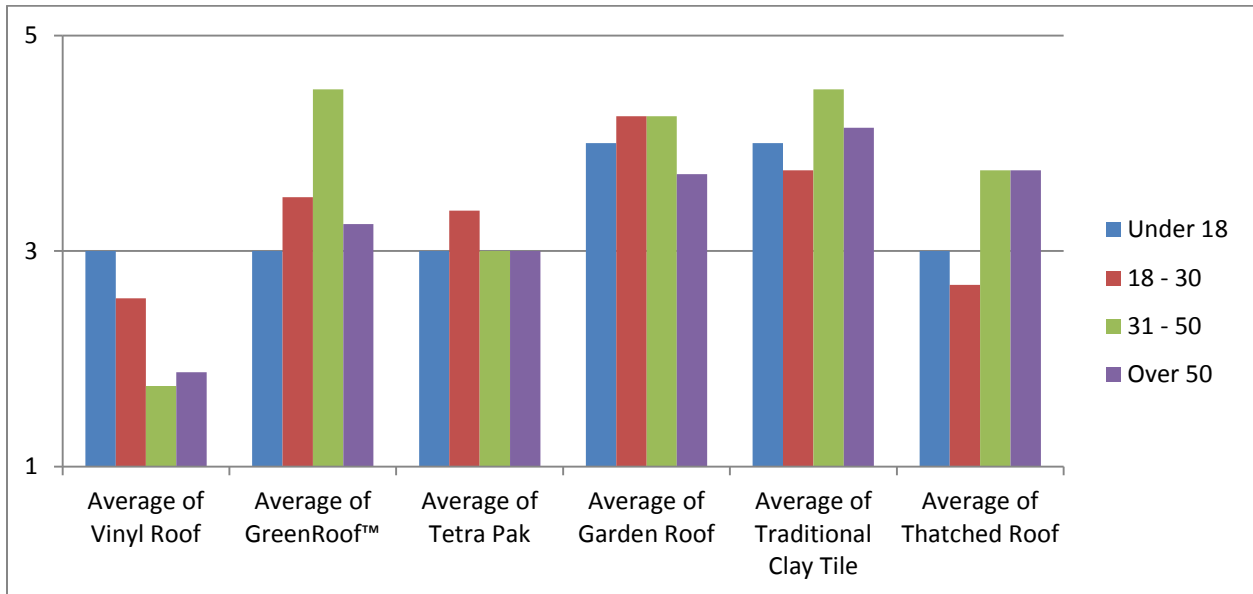

FIGURE 20: OPINIONS OF ROOFING OPTIONS BY AGE GROUP

When broken down by education levels, our group intended to further uncover where the main point of education on the environment occurred. Earlier knowledge would be essential to earlier and more effective implementation. Just as a general demographic observation, our group noticed that most of our sample consisted mainly of highly educated people, with the majority of our respondents having a bachelor's degree or higher. This is shown in Figure 21. Those with a bachelor's degree or higher preferred the clay tiles, GreenRoof™, garden roof, and the thatched roof the best. Those with an education less than a bachelor's also preferred clay tiles and the GreenRoof™, but then preferred almost all other options equally.

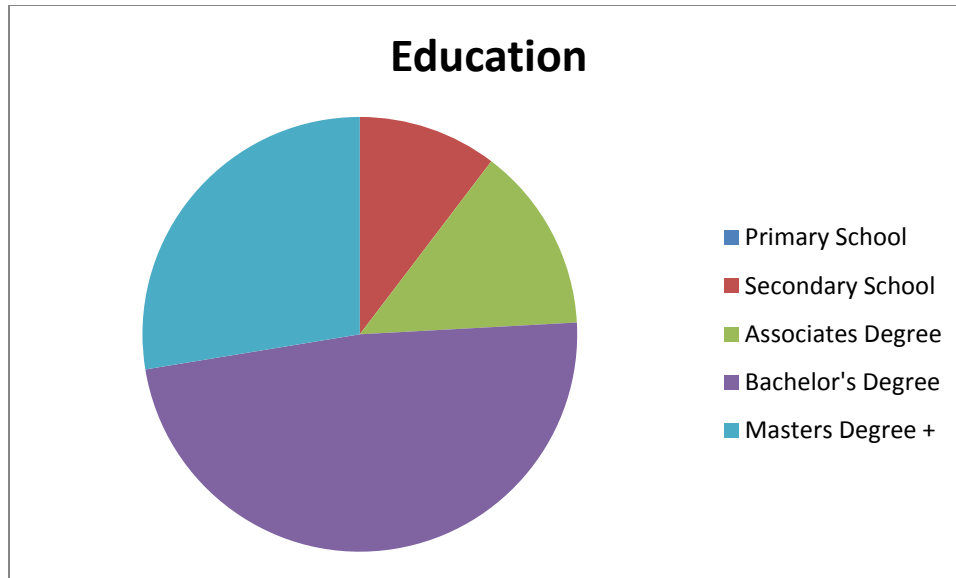

FIGURE 21: SURVEY RESPONDENT DEMOGRAPHIC BY EDUCATION

4.2: ANALYSIS OF FINDINGS

One of the most important factors in choosing the best solution to the roofing and pollution problem was to analyze the life cycles of each of the materials we considered. These can be seen in Appendix E. We recognized that pollution was the main issue at hand and our roofing material should help to quell this increasing problem. Therefore, the amount of pollution that each material produced or prevented was analyzed thoroughly before discussing physical solutions.

Currently, Tetra Pak cartons are an unavoidable source of pollution throughout Thailand. They are produced in order to distribute a variety of drinks throughout the country, and help preserve and provide milk to students in schools. Unfortunately Tetra Pak production leads to the need for their disposal, and without proper recycling techniques, these cartons are incinerated. This leads to pollution of the air, and in Chiang Mai, any pollution created stays stagnant over the valley in between all its mountains. Old Chiang Mai is located in this valley, and continues to be polluted more and more each day by these cartons. Therefore, finding a roofing solution that would prevent these cartons from being burned would help to subdue the pollution problem in Chiang Mai.

Chapter 4: Findings and Analysis

However, by simply creating a roof out of the cartons, Tetra Pak incineration is not prevented. Our group realized that after the roof fails over the course of a maximum of five years, the roof would then have to be disposed of. This disposal will result in the original pollution problem that we were trying to solve. Unfortunately we cannot project any other outcome for the deteriorated roof than incineration or in a landfill. If this was the case, the life cycle of the Tetra Pak would ultimately end with incineration or landfills, no matter what steps were taken in between.

In the construction industry, cement is one of the most commonly used materials. In 2008, the amount of cement consumption exceeded one billion metric tons (Cement Americas, 2004). Although useful for a wide spectrum of construction projects, the processing of cement produces very large quantities of carbon dioxide gas. According to the U.S. Energy Information Administration (EIA), the production of cement is the United States' largest source of carbon dioxide emission other than the fossil fuel combustion (U.S. Energy Information Administration, 2009). Although we could not find an exact record of carbon dioxide emissions resulting from cement in Thailand, we can assume that the proportion will be similar to the United States' emissions. Therefore, we can assume that cement is one of the main sources of carbon dioxide emissions in Thailand. To produce 100 kilograms of cement, ninety kilograms of carbon dioxide will be produced (Mahasenan, Smith, & Humphreys, 2007). If we could find a way to reduce the cement produced, we would ultimately be helping the environment.

There are benefits to using cement that are evident through its life cycle analysis as well. Cement roofing tiles have an average life of fifty years, and it is possible for them to last longer than that depending upon the weather conditions in which they reside (Roof Inspection Solutions, 2011). Once they break down, they can be ground up and recycled as an aggregate or as gravel for a driveway or a road. Although the cement may initially produce a large amount of carbon dioxide, its life cycle is significantly longer than many other options.

Styrofoam is composed of several materials, including styrene, benzene, and ethylene as well as blowing agents such as Chlorofluorocarbons (CFC). These chemicals are extremely

Chapter 4: Findings and Analysis

toxic and can be a health hazard to the people around the production process. The CFCs have also been known to cause ozone depletion which ultimately leads to global warming. After the useful life of a Styrofoam product is complete, the waste is brought to a landfill. Styrofoam takes nearly five hundred years to completely decompose. Because of its volume and slow decomposition process, Styrofoam now occupies 25-30% of the landfills in the United States. It can be assumed that similar figures would be prevalent in Thailand due to similar waste distributions. If burned improperly in landfills, Styrofoam can release over ninety different toxic chemicals into the air, which will only expedite the air pollution in Chiang Mai. Therefore, Styrofoam will pollute the ground or the air, both of which endanger the environment (Kremer, 2003).

Ceramic roofing tiles must be fired in order to change their properties to a water resistant material. Therefore, some type of heat source must be used, and the process of creating a ceramic tile becomes harmful to the environment. Sulfur, fluorine, and lead compounds are all released into the air in their gaseous form, but in amounts that are only moderate when firing clay. In fact, when we compared this firing process with processes to create other roofing materials, ceramic tile production was one of the overall cleaner processes. If broken clay to make these tiles is disposed of as waste in small quantities, it rarely has any negative effect on the soil, and does not affect vegetation in the immediate area (Baby, 2010). During its life as a roofing tile, ceramic is strong, durable, and holds up well in mild weather. They have a lifespan of fifty to seventy-five years and usually do not lose any aesthetic properties. Once they are broken, they can be ground up again and replaced into the soil if not polluted by other chemicals. Otherwise, the ceramic can be ground up and used as an aggregate to create more clay for other purposes besides roofing (Vigener & Piteo, 2007).

Plaster is a greener alternative to using cement. It produces far less carbon dioxide emissions than cement due to the lack of the calcination process. The production is also an energy efficient process and does not require a large amount of electricity or fossil fuel powered processes. This is another means to reduce pollution on the environment.

Chapter 4: Findings and Analysis

With one of the worst production processes in the market for the environment, asphalt roofing creates Polycyclic Organic Matter as well as a number of toxins. Both of these are regulated by The Clean Air Act in the United States because they were deemed dangerous to the environment. Therefore, asphalt was completely out of the question for this project (Environmental Task Force, 1998).

Our goal for this project was to reduce the pollution in Chiang Mai by implementing waste materials into the clay house roofing system. Therefore, after the life cycle analysis, we decided as a group that any roofing option that did not implement waste products would not fulfill the goals of our project. With this decision, several potential solutions such as clay and wax, clay and cement, and clay and plaster were discontinued, and ruled as non-solutions.

After our testing procedures, several other materials were removed from our potential recommended solutions list. All the clay, cement, and plaster solutions had to be immediately discontinued because none of these solutions would stand up to the heavy rains that occur so often during the rainy season. This was backed up with the data that Joy Friedman provided us during her interview. She told us that only fired clay would fulfill all the necessary functions of a roofing material, and therefore unfired clay would most likely never function correctly. Ms. Friedman proved to be right after all our clay models completely disintegrated in water over night.

Our next elimination from the list of possible materials was based on the prototype performance. We were able to eliminate our first carton design which incorporated hidden edges while still considering the corrugated and vinyl hybrid simply because we knew that the later developed solutions would work better and were just as easy to install. The solely vinyl solution was also eliminated because of its demand for too many materials. It was extremely unlikely for a person to acquire as many vinyl sheets as the roofing design demanded. As part of our analysis, we determined that four vinyl sheets were used in the making of our model. Therefore, we estimated that approximately 150 of our prototypes would fit onto the roof of the clay house. This would require a total of six hundred vinyl sheets, which simply is unreasonable for any one person to acquire easily.

Chapter 4: Findings and Analysis

We also determined that all of the carton solutions would never be as aesthetically pleasing as the other solutions. There was no inexpensive, environmentally friendly way to prevent the cartons from extreme UV exposure. Therefore, the plastic layer would inevitably peel off and cause an unsightly appearance. However, the cartons would still be able to function without this layer and may still allow for a functional roof over time.

After researching more about botanical roofing systems, we discovered that waste materials that are readily available in Chiang Mai can be used to correctly construct a green roof. Chip bags may be able to serve as a waterproofing layer and the large amount of food waste can be used as compost in the growing medium. Plastic bags can create a drainage layer by thatching them together, and an additional layer of widely thatched plastic bags may also serve as means to hold the growing medium in place on the sloped roof. Once the roof is constructed, there are a plethora of plants that have the ability to grow in high sunlight exposure and would make the roof much more aesthetically pleasing. Not only does this green roof allow for citizens to build the roof themselves, but it also reverses the effects of pollution instead of just reducing it. This biomaterial would be able to remove toxins in the air around Chiang Mai as well as create a more temperate environment if enough green roofs were installed. There would be no waste as a result of this system, and the roof itself is easy to repair.

The Tetra Pak GreenRoof™ would also make for an extremely feasible option for multiple reasons. Tetra Pak recycles the entirety of the Tetra Pak carton, and the result of the recycling process results in a zero waste production process. If the people of Chiang Mai worked together, they would be able to collect the Tetra Pak from schools and temples, and send them to the recycling plant in Bangkok. In return, the company may be able to provide the city with low cost roofing materials that would last upwards of ten years. Although the recycling process may not be entirely green, it may be worth studying whether Tetra Pak incineration creates more pollution than this recycling process. In this case, it might be a situation in which the lesser of two evils must be chosen.

The data compiled from the surveys was informative once it was gathered into one place. It was strongly evident to our team that many Chiang Mai citizens were willing to put in the

Chapter 4: Findings and Analysis

effort to implement green roofing techniques. However, each age group seemed to believe that a different technique was better to tackle the environmental side of the roofing issue. Younger generations liked both roofing materials that were familiar to them already, and the new and innovative ways of creating an environmentally friendly roof. Older generations preferred the familiar options as well as the more traditional looking options for a roof. These patterns made it clear that the green roof satisfied both the old-fashioned aesthetic desires expressed by the older generation, and the new innovative technology the younger generation desired. Cement and Tetra Pak tiles were a familiar looking material that incorporated waste products, and therefore were acceptable to both main age groups as well.

The Tetra Pak hybrid roof and the green roof are two very new developing solutions to the environmentally friendly roofing problem. According to our analysis, both materials would be acceptable amongst most Chiang Mai citizens; however, they are not highly favored. With more research, development, and publication, these materials might become more acceptable to the people and eventually be able to be implemented in cities, suburban areas, and rural areas. They are new technologies that do not interfere with the integrity of the traditional culture of Chiang Mai, and will help to preserve the beauty and longevity of this city.

CHAPTER 5: RECOMMENDATIONS AND CONCLUSIONS

Careful analysis of our findings led us to discover that our original problem was much more complex than previously anticipated. We discovered that environmentally friendly roofing alone would not be able to reduce the increasing pollution in Chiang Mai. Therefore, our group was pushed to widen the scope of our recommendations in order to develop more creative solutions.

In addition to our environmentally friendly roofing designs, our group decided to recommend alternate ways that the UDIF can continue to reduce pollution in Chiang Mai. A combination of the data we had collected, along with our own personal experiences, allowed for the development of these supplementary recommendations. Our hope is that a synthesis of sustainable housing with our additional recommendations will enable the UDIF to truly make Chiang Mai a cleaner city.

ROOFING RECOMMENDATIONS

Over the course of this project, our team tested and designed several roofing methods developed from clay, cement, Tetra Pak, and vinyl. These potential solutions were completely innovative and have not been otherwise tested. Case studies were also researched to determine if methods from elsewhere in the world would be appropriate to implement as solutions. The following designs were chosen due to their likelihood of success and ability to accomplish all of the goals of this project. Benefits of each selected design are summarized in Figure 22.

Chapter 5: Recommendations and Conclusions

<i>Recommendation</i>	Utilizes Waste Products	Environmentally Friendly	Greenhouse Gas Reduction	Easy to Install	Easy to Construct
Corrugated Tetra Pak with Vinyl	●	●			●
Cement with Shredded Tetra Pak	●	●		●	●
Garden Roof	●	●	●		●
GreenRoof Processed Tetra Pak	●	●		●	

FIGURE 22: SUMMARY OF RECOMMENDATIONS

Small prototypes of some selected designs were constructed and installed at the site of the UDIF for durability testing. We recommend that the UDIF allow this durability testing to continue for at least two years. During this testing, qualitative evaluations can be made for each of the solutions to determine which will best endure the weather of Chiang Mai. Additionally, the prototypes will be able to be compared to the current roof after this two-year period, making it possible to decide which method is best when a replacement is necessary. Although several models were left for observation, we recommend that the UDIF focus most of their efforts on two of these solutions: the cement and Tetra Pak tiles, and the corrugated Tetra Pak and vinyl.

Our team developed several roofing designs made solely of either Tetra Pak or vinyl. However, based on our preliminary testing, we deemed the Tetra Pak and vinyl hybrid model to be the most successful of this particular group. The carton patterning was designed to prevent the edges from curling when damp. Furthermore, strips of vinyl posters protect the top ridges of the corrugations from rainwater exposure, thus reducing leakage and fungus build up. Utilizing vinyl will also help to protect the cartons' edges from UV rays, hopefully extending their life and reducing peeling (Decker, 1984). Its hybrid nature will maximize water-resistivity, structural integrity, and aesthetics while reducing the amount of labor and the amount of vinyl posters needed. This solution requires a large number of Tetra Pak cartons, thus reducing the amount that is burned and hence the pollutants released. The building process also does not require any further manufacturing, minimizing the amount of carbon dioxide being produced. To improve this design, we recommend further testing to explore possible ways to extend the lifespan of the cartons.

Chapter 5: Recommendations and Conclusions

The second solution we recommend is the cement and Tetra Pak tiles. Because of the availability of the required materials, this solution can be easily constructed in rural areas. This increases its potential to be implemented, and thus also increases its potential to actually help reduce the pollution. During our testing, this material proved to be exceptionally strong, which supported our research that cement can last upwards of fifty years. These hybrid tiles are slightly lighter-weight than the traditional cement tiles due to the presence of the carton pieces. Actual tile construction does not involve any processing that produces carbon dioxide. Plus, the reduction of cement quantities needed reduces greenhouse gas emissions created during its initial production phase. Creating the tiles is not a complex process, meaning that the tiles can be self-made. An additional benefit would be that local business may be enhanced if a small company were to manufacture these tiles for citizens in close proximity. Tiles are aesthetically pleasing and similar to traditional clay tiles that have been used in the past. We recommend that the UDIF observe the prototype we have constructed in order to ensure its durability.

During our research, we discovered two potential roofing solutions that have already been used in various areas of the world: GreenRoof™ and the garden roof. Our team recommends each of these solutions under different criteria, as each of them more specifically fulfills different goals.

We recommend the GreenRoof™ as a solution to prevent the incineration of Tetra Pak as well as serve as a durable, long-lasting roofing material. The GreenRoof™ has a projected life-span of about ten years and has successfully passed factory testing for water resistivity, fire resistivity, strength, and durability. This solution would be easy to implement in rural areas because their current tin roofs have a similar structure to the GreenRoof™. Local people are familiar with how to build with these materials, and additional hassle would not hinder installation. As a stipulation, we recommend that the UDIF look further into the company and determine the effects the manufacturing process has on the environment. If this construction method is found not to be environmentally damaging, we recommend that the UDIF establish a professional relationship with this company.

Our final roofing recommendation is the installation of a garden roof. This solution has proved successful in many countries around the world, including southern Thailand. Next to the clay tiles that top the majority of current Thai houses, the garden roof received the most positive feedback from our survey respondents. Additionally, waste materials can be utilized in the design. For example, egg-cartons can be used for the drainage layer, plastic bags for the waterproofing layer, and composted organic waste for the growing medium. The use of biodegradable materials in the growing medium can even improve the health of the plants. Photosynthesis can then occur more efficiently ultimately reducing the amount of toxins in the air. Although this solution requires a very sturdy structure to contain the growing medium, and once built, the solution is quite self-sustainable. We recommend that the UDIF looks more in-depth into the best method of construction for this solution. Terracing or the use of mesh wiring may help to ensure that heavy rains do not create runoff that erodes away the growing medium.

ADDITIONAL RECOMMENDATIONS

As we approached the end of our project, our group revisited the original problem and our objectives to solve it. We discovered that although our environmentally friendly roofing solutions may help to reduce the amount of pollution in Chiang Mai, it only would partially solve the problem. Therefore we decided it was necessary to suggest other ways the UDIF could achieve their environmental goals for Chiang Mai.

While each of our prototypes incorporate waste, overall they do not reduce pollution. Instead, they simply prolong the life cycle of waste that will need to be disposed of once again. Food packaging is a large portion of the trash being incinerated or put in landfills that causes the pollution (Urban Development Institute Foundation, 2002). For that reason, we feel that it is necessary to take action by advocating for packaging that is fully recyclable or biodegradable. By educating citizens about the benefits to this packaging, a change in the consumer attitudes will develop. Subsequently, more packaging companies may then adopt this environmentally friendly packaging, and waste would be recycled or have the natural ability to degrade safely.

Chapter 5: Recommendations and Conclusions

The UDIF's ultimate goal is large and will require support. Based upon our findings, we recommend that the UDIF recruit two research teams to expand upon our work and help to achieve this goal. One possibility is to recruit another IQP-ISSP team to do this research.

We recommend that the first group be formed with the purpose of publicizing the UDIF to a larger audience and educating the citizens of Chiang Mai about its mission. This group should help to develop comprehensive educational programming regarding the environmental concerns with pollution and its consequences. An effective and widespread recycling program should be another goal for this group. Many of the products that ultimately end up incinerated or put in landfills have the ability to be recycled safely elsewhere in the world. Unfortunately, many of these recycling methods are yet unknown to people who are not given adequate information. Therefore, the UDIF may be able to be a collection center to encourage recycling programs such as TerraCycle™ for snack bags and GreenRoof™ for Tetra Pak.

A second group should be formed in order to determine exactly where the majority of the pollution in Chiang Mai is coming from. The burning of Tetra Pak and other non-recyclable waste is only one factor contributing to the air pollution. We suggest that all sources of pollution be identified so that the main causes of air quality deterioration can be addressed. Once this information is found, the UDIF can target these specific issues more easily.

CONCLUSION

Improper waste management in Chiang Mai, as well as the geography of the setting, has contributed to the rapid increase in pollution. Consequently, the health of both Chiang Mai's citizens and also of the environment has been compromised. The Urban Development Institute Foundation suggests that sustainable housing is a method to reduce this increasing pollution.

While looking for an appropriate solution to meet our goals, we developed a list of objectives that allowed us to address both the technical and social aspects of our problem. Not only did we want a durable roofing material that incorporated waste products, but also for our recommendations to be accepted and implemented by Chiang Mai citizens. To do

Chapter 5: Recommendations and Conclusions

this, we had to research the materials contributing to the pollution of Chiang Mai, investigate plausible options, and finally build and test our prototypes. However, this needed to be completed in compliance with the opinions of Chiang Mai's citizens. Acting in accordance with their social consciousness ensures that our recommendations would provide an acceptable solution.

Through the site assessment and sponsor interview, we realized that the current roof needed to be replaced not only for structural reasons, but for social reasons as well. The roof needed to be successful in protecting its inhabitants, and successful in reducing the pollution. Ecological principals of the UDIF helped to guide our materials assessment, and we were sure to make their ideals evident throughout our design process. Once most of our research and development was complete, we reflected on our process and realized that there was not just one simple solution to the pollution problem. For example, if the scientific aspects of our goal were fulfilled, the human dimensions might have been compromised. Because our objectives had included material, procedural, and social components, any single recommendation would place one criterion above the rest. In actuality, this project required our group to find a balance between all these elements. To keep this balance, we made many recommendations, each having their own positive and negative characteristics.

Though we were not able to find a perfect solution to fit all the needs of the UDIF, we were able to provide them with valuable data about both material properties and the desires of the community. With this, the UDIF can continue their research on sustainable roofing by using our prototypes and following our recommendations. Although this project was very complex and multi-faceted, it provided valuable and unique experience for every member of the group. Working in a situation that was outside the scope of our previous experiences was both challenging and rewarding. We learned about each other and were able to teach one another different aspects of our own cultures. Despite the cultural differences of the Thai and American students, we were able to bring our knowledge and different strengths together in order to solve a problem that affects an entire city. We had to focus on the collaboration of science and society, which was a new experience for each member of our

Chapter 5: Recommendations and Conclusions

group. Overall, the experience was beneficial to all of our group members and we hope it was equally beneficial to our sponsor and the residents of Chiang Mai.

BIBLIOGRAPHY

- Ahmed, M. H. (2008). *Mix Design of Styrofoam Concrete*. Retrieved from Universiti Tenaga Nasional:
<http://www.uniten.edu.my/newhome/uploaded/coe/iccbt/iccbt%202008/conference%20a%20extract/UNITEN%20ICCBT%2008%20Mix%20Design%20of%20Styrofoam%20Concrete.pdf>
- Andy Sutton, e. a. (2011, November). *Unfired Clay Masonry*. Retrieved from BRE:
http://www.bre.co.uk/filelibrary/pdf/projects/low_impact_materials/IP16_11.pdf
- Auroville Earth Institute. (2009). *Earth as a Raw Material*. Retrieved from Earth Architecture: http://www.earth-auroville.com/raw_material_introduction_en.php
- Baby, S. (2010). Environmental Evaluation for Porcelain and Ceramic Factory. *International Conference on Chemistry and Chemical Engineering* (pp. 438-443). Kyoto: ICCCE. Retrieved from
<http://ieeexplore.ieee.org/stamp/stamp.jsp?tp=&arnumber=5560345>
- Byun, K. J. (2012). *Development of Structural Lightweight Foamed Concrete Using Polymer Foam Agent*. Retrieved from <http://parkss87.com.ne.kr/foam.pdf>
- Cement Americas. (2004, November 1). *China's Cement Demand to Top 1 Billion Tons in 2008*. Retrieved from Cement Americas:
http://web.archive.org/web/20090427075804/http://cementamericas.com/mag/cement_chinas_cement_demand/
- Chiang Mai Publishing Co. (2004). *Chiangmai Mail*. Retrieved from Our Community:
<http://www.chiangmai-mail.com/327/community.shtml>
- Creative Urban Solution Center. (2012, January 18). Molding Milk Cartons. Chiang Mai, Thailand: Creative Urban Solution Center. Retrieved from
<https://www.facebook.com/photo.php?fbid=254235661317078&set=a.254235531317091.61475.151014138305898&type=1&permPage=1>

Bibliography

- Decker, C. (1984). Degradation of Polyvinyl Chloride by U.V. Radiation. *European Polymer Journal*, 149-155. Retrieved from ScienceDirect.
- Demetry, D. C. (2012, January 18). (A. Fidanza, Interviewer)
- Discovery Channel. (2010, April 2). How It's Made: Concrete Roofing Tiles. Retrieved from <http://www.youtube.com/watch?v=8IoKoHnjb4Q>
- Domingo, R. (2003). *RTD Online*. Retrieved from Zero Management: <http://www.rtdonline.com/BMA/MM/13.html>
- Environmental Task Force. (1998, September). *Polyaromatic Hydrocarbon Emissions from Asphalt Processing and Roofing Manufacturing Operations*. Retrieved from Owens Corning: Innovations for Living: http://www.owenscorning.com/trumbull/resources/downloads/polyaromatic_emissions.pdf
- European Federation of Green Roof Associations. (2010, January). *EFB*. Retrieved from European Federation of Green Roof Associations: <http://www.efb-greenroof.eu/>
- Findhorn Ecovillage. (2011). *The Low Carbon Revolutions Start at Home*. Retrieved from Ecovillage Findhorn: New Frontiers for Sustainability: <http://www.ecovillagefindhorn.com/findhornecovillage/ecological.php>
- Friedman, J. (2012, January 13). (A. Fidanza, Interviewer)
- Glassman, J., & Sneddon, C. (2003). Chiang Mai and Khon Kaen as Growth Poles: Regional Industrial Development in Thailand and its Implications for Urban Sustainability. *The ANNALS of the American Academy of Political and Social Science*, 93-115.
- Green Roofs. (2012, January 26). *Green Roof Benefits*. Retrieved from Green Roofs for Healthy Cities: <http://www.greenroofs.org/index.php/about-green-roofs/green-roof-benefits>
- GreenGarage. (2007). *Modern and Green Roof Design*. Retrieved from Green Garage: <http://greengarage.ca/img/exploded-layers.gif>

Bibliography

- GreenRoof. (2012, January 14). *GreenRoof*. Retrieved from GreenRoof:
<http://www.greenroof.in.th/>
- Hren, S. (2011, May 5). Green Roofs: All You Need to Know. The Huffington Post. Retrieved from http://www.huffingtonpost.com/2009/01/14/green-roofs-all-you-need_n_157935.html
- Huntzinger, D. N., & Eatmon, T. D. (2006, October 26). A life-cycle assessment of Portland cement manufacturing: comparing the traditional process with alternative technologies. pp. 668-675. Retrieved from ScienceDirect:
<http://www.sciencedirect.com/science/article/pii/S0959652608000826>
- Intertek Plastics Technology Laboratories. (2012). *Water Absorption 24 Hour/Equilibrium*. Retrieved from Intertek Plastics Technology Laboratories:
http://www.ptli.com/testlopedia/tests/water_absorption-d570.asp
- Kieran, K. (2010, February 4). *GreenWala: Live Life Greener*. Retrieved November 1, 2011, from RECY-BLOCKS: ECO-BUILDING MATERIAL MADE OUT OF 100% PLASTIC TRASH!: <http://www.greenwala.com/channels/green-business/blog/4591-Recy-Blocks-Eco-Building-Material-Made-Out-Of-100-Plastic-Trash>
- Kinkade-Levario, H. (2007). *Design for water: Rainwater Harvesting, Stormwater Catchment, and Alternate Water Reuse*. New Society Pub.
- Kremer, A. (2003). *Cradle to the Grave: The Life Cycle of Styrofoam*. San Francisco: San Francisco State University.
- Mahasenan, N., Smith, S., & Humphreys, K. (2007). *The Cement Industry and Global Climate Change: Current and Potential Future Cement Industry CO2 Emissions*. ScienceDirect.
- Mandarin Oriental Dhara Dhevi. (2012). *Mandarin Oriental Dhara Dhevi*. Retrieved from Mandarin Oriental Dhara Dhevi: <http://www.mandarinoriental.com/chiangmai/>

Bibliography

- Materia Inspiration Centre. (2010). *Materia*. Retrieved November 1, 2011, from Recy-Block: http://www.materia.nl/575.0.html?&user_material%5bmaterial_uid%5d=1526&cash=eed876d4e1
- MonierLifetile. (2011). *Roof System Components*. Retrieved November 14, 2011, from Monier Lifetile: <http://www.monierlifetile.com>
- Northern Thailand Public Relations Group. (2007, June 30). *Chiang Mai Geography: Location*. Retrieved from Chiang Mai City of Life and Prosperity: <http://chiangmai-info.prnorth.in.th/chiang-mai-info-geography.php>
- Oberndorfer, E., Lundholm, J., Bass, B., Doshi, H., Kohler, M., Liu, K., & Rowe, B. (2007). Green Roofs as Urban Ecosystems: Ecological Structures, Functions, and Services. *BioOne: Research Evolved* (pp. 823-833). American Institute of Biological Sciences.
- Ohno, T., & Xihui, W. (2008, May). Outline of Conventional Construction Systems for Pitched Roofs in Eastern Asia. *Journal of Asian Architecture and Building Engineering*, 7(1), 101-107.
- Ribeiro, G., & Srisuwan, A. (2005). Urban Development Discourses, Environmental Management and Public Participation: the Case of the Mae Kha Canal in Chiang Mai, Thailand. *Environment and Urbanization*, 17(1), 183.
- Ricks, R. (2010, March 29). *Health in Thailand*. Retrieved from Health in Thailand: <http://healthinthailand.wordpress.com/>
- Roof Inspection Solutions. (2011, April 7). *Concrete Roof Tile*. Retrieved from Roof Inspection Solutions: <http://www.roofkey.com/concrete-roof-tile.html>
- Roof101.com. (2007). *Rubber Shingles*. Retrieved November 14, 2011, from Roof 101: <http://www.roof101.com/roof-shingles/rubber-shingles.php>
- Sandvik Hard Materials. (2008). *Mechanical Strength*. Retrieved from Your Perfect Partner: Cement Carbide: http://www.allaboutcementedcarbide.com/01_04.html

Bibliography

- Sittitrai, W. (1998). *Rural Transformation in Northern Thailand*.
[http://scholarspace.manoa.hawaii.edu/handle/10125/10113?show=full:](http://scholarspace.manoa.hawaii.edu/handle/10125/10113?show=full)
University of Hawaii.
- TerraCycle. (2012, February 18). *About Us*. Retrieved from TerraCycle: Ourtsmart Waste:
<http://www.greenroofs.org/index.php/about-green-roofs/green-roof-benefits>
- Tetra Pak. (2012). *About the Package*. Retrieved from Get to Know our Carton Packages
Better: <http://campaign.tetrapak.com/lifeofapackage/what-its-made-of/>
- Thai Industrial Standards Institute. (2012). *Thai Industrial Standards Institute*. Retrieved
from Ministry of Industry: <http://www.tisi.go.th>
- Thomas. (2008, February 27). *Air Pollution Levels in Chiang Mai Rising*. Retrieved from
Earthoria: <http://www.earthoria.com/air-pollution-levels-in-chiang-mai-rising.html>
- Thompson, L. (2011, November 14). Timber Framed Green Roof. (C. Bannish, Interviewer)
Ko Kood, Thailand.
- U.S. Energy Information Administration. (2009). *Emissions of Greenhouse Gasses Report*.
Washington, D.C.: U.S. Department of Energy. Retrieved from
<http://www.eia.gov/oiaf/1605/ggrpt/carbon.html>
- United Nations Environment Programme. (2007). *Source Book of Alternative Technologies
for Freshwater Augmentation in some countries in Asia*. Retrieved November 13,
2011, from United Nations Environment Programme:
<http://www.ietc.unep.or.jp/ietc/publications/techpublications/techpub-8e/rainwater2.asp>
- University College of London: Department of Earth Sciences. (2012). *Clays and Clay
Minerals*. Retrieved from Geology in the Landscape and Buildings of London:
<http://www.es.ucl.ac.uk/schools/UCL/clays.htm>

Bibliography

- Urban Development Institute Foundation. (2002). *Creative Urban Solutions Center*. Retrieved from Urban Development Institute Foundation: <http://www.udif.or.th/>
- Urban Development Institute Foundation. (2010, December 15). *YouTube.com*. Retrieved November 1, 2011, from Building A Clay House "Baandin Klangweing": <http://www.youtube.com/watch?v=mFT2XVjkd94>
- Vigener, N., & Piteo, N. (2007). 4 Points to Consider with Clay Tile Roofing. *Buildings*, 28.
- Watcharamul, D. S. (2012, January 12). Waste in Chiang Mai Landfills. (P. Rungthanaphatsophon, Interviewer)
- Wilaipon, P. (2009). The Effects of Briquetting Pressure on Banana-Peel Briquette and the Banana Waste in Northern Thailand. *American Journal of Applied Sciences*, 167-171.
- Yee, L. L. (2010). *Load-Deflection Behavior of Biocomposites Beam*. Malaysia: Universiti Teknologi Malaysia.

APPENDICES

APPENDIX A: DETAILED TESTING PROCEDURES

Transverse Rupture Test (for Tiles)

For this test, each tile was placed between two level tables with a stick placed horizontally across the middle. A bucket was attached to this stick, which was then filled with water, 100 milliliters at a time. Water was added into the bucket until the tile failed catastrophically. The amount of water put in was recorded.

Water Test (for Tiles)

Each sample was placed in a bucket full of water. The sample was then left in the water for 24 hours. After the 24 hours, the sample was taken out and analyzed qualitatively.

Water Test (for Cartons)

The Carton-based roofs were sprinkled for one minute with water to simulate rain. The prototype was then analyzed to see if any leaking occurred or if there was any collection of the water in gaps. The prototype was then placed at the same angle as the roof and once again sprayed with water to determine how the run-off worked, making sure it led away from under the roof.

Fire Test (for Cartons and Tiles)

Place flammable materials on and under the tile. Light materials on fire and observe any negative effects suffered by the tile. Specifically, does the material melt, catch fire, or disintegrate, etc.? This is strictly a qualitative test and does not acquire any specific numerical data. However, the fireproof properties of the material are observed.

Appendices

APPENDIX B: TESTING RESULTS

Material	Durability Test	Strength Test	Water Test	Fire Test	Conclusion
<i>Test Description</i>	<i>Effect of Weather</i>	<i>Force Withstood (N)</i>	<i>Reaction to Water Soaking</i>	<i>Reaction to Open Flame</i>	
Clay, Cement, Styrofoam	N/A	9.81	Dissolved	None	Not Feasible
Clay, Cement, Tetra Pak	N/A	27.468	Dissolved	Edges Burnt	Not Feasible
Clay, Cement	N/A	49.05	Dissolved	None	Not Feasible
Clay, Cement, Vegetable Oil	N/A	N/A	Dissolved	None	Not Feasible
Clay, Plaster, Styrofoam	N/A	51.012	Dissolved	None	Not Feasible
Clay, Plaster, Tetra Pak	N/A	49.05	Dissolved	Edges Burnt	Not Feasible
Clay, Plaster	N/A	51.012	Dissolved	None	Not Feasible
Clay, Wax	Severe Warping	31.392	None	Melt	Not Feasible

APPENDIX C: INTERVIEW QUESTIONS

- Initial Discussion with Duongchan Charoenmuang:
 - Can you summarize the founding and history of the UDIF?
 - What is the broader problem you are trying to solve by creating this sustainable house?
 - What are the current problems with the Tetra Pak roof?
 - What materials are not acceptable to use in the construction of the new roof?
 - Are there any construction processes that are unacceptable?
 - What materials are commonly found in landfills?
 - What waste materials are available for us to experiment with at your facility?
 - Are there any additional restrictions for this project? Any additional expectations?
- Interview builders of old house to determine:
 - What were the problems faced when building the roof?
 - How long did it take to put up the roof?
 - In your opinion, would the general public be able to assemble the roof that you put up.
 - How many people do you think it would take to put the roof up in a reasonable amount of time?
 - Would it be worth it for people to rebuild it every five to ten years?
 - If it worked would you consider using it on your own houses? Why or why not.
- Interview Architecture students about feelings about recyclable roofing.
 - What Aesthetic choices would you like to see incorporated into a sustainable roof?
 - Would you consider putting one on your house when you own your own?
 - Do you foresee this be a viable option for the public?
 - What would make it a better option for the public?
- Interview citizens: a group of 3 goes out on interviews while other group is building.
 - Aesthetic choices of the roof. Which design they like best and why?

Appendices

- Would they be interested in building their roof out of the recycled materials?
- Would it be viable in terms of labor and projected longevity?
- Is it something that they feel would gain support/interest in the community?

APPENDIX D: SURVEY

Study of Roofing Options in Chiang Mai - Survey for Opinion



---Chulalongkorn University and Worcester Polytechnic
Institute---



We would appreciate hearing your opinions about what is essential to you when it comes to a roofing material for your own home. All surveys will remain anonymous and will be used strictly for statistical purposes. This survey should take only five minutes to fill out. Thank you for your time!

Roofing Material Properties:

Please order the following roofing characteristics in order from 1-9 of how important they are to you. (1 being the most important, 9 being the least important)

- ___ Cost of Material
- ___ Ability to Self-Install
- ___ Duration of Installation
- ___ Cost of Labor
- ___ Durability/Lifespan of Material
- ___ Weatherproof Properties of Material
- ___ Aesthetics
- ___ Ease of Construction
- ___ Use of "Green Materials"

Physical Appearance:

Which of the following roofing options looks best to you? Please assess the physical appearance of each sample on a scale of 1(not physically appealing)-5(very physically appealing).

Sample 1	1	2	3	4	5
Sample 2	1	2	3	4	5
Sample 3	1	2	3	4	5
Sample 4	1	2	3	4	5
Sample 5	1	2	3	4	5

Green Materials

Please rank the following on a scale from 1(not important)-10 (extremely important) based on your personal opinion

The prevention of pollution by reducing the number of processed roofing materials used:

- 1
- 2
- 3
- 4
- 5

The incorporation of waste products into products such as roofing materials to prevent waste incineration:

- 1
- 2
- 3
- 4
- 5

The durability of a roof made of waste products:

Appendices

1

2

3

4

5

General Information

Where is your hometown?

Bangkok Chiang Mai Other _____

Where is your home located? (check please)

Urban Area Suburban Area Rural Area

Did you install your own roof?

Yes No

What is your highest education?

Primary school Secondary school Associates Bachelors Masters

Are you concerned with Global Warming?

Very Concerned A little concerned Neutral Not Really Concerned

Not concerned

What are you more concerned with?

Price of Product Environmental Impact

Additional Comments/Concerns/Suggestions:

Appendices

APPENDIX E: SUMMARY OF ALL FINDINGS

Roofing Method	Problems	Conclusion
Corrugated Cartons		Implemented
Original Roof	Curling Edges, Peeling Plastic	Implemented
Carton Wrapped in Tarp	Labor Intensive	Not Feasible
Cartons with UV Paint	Toxic, Expensive Paint	Not Feasible
Clay with Teak Sawdust	Termites, Absorbs Water	Not Feasible
Clay with Waterproof Paint	Potentially Toxic Paint	Not Feasible
Clay, Banana Leaves	Banana Leaves Not Plentiful	Not Feasible
Clay, Cement	Dissolves in Water	Not Feasible
Clay, Cement, Carton	Dissolves in Water	Not Feasible
Clay, Cement, Styrofoam	Brittle, Dissolves in Water	Not Feasible
Clay, Cement, Vegetable Oil	Incredibly Weak	Not Feasible
Clay, Petroleum Jelly	Expensive, Creates Demand for Fossil Fuels	Not Feasible
Clay, Pineapple Peels	Pineapple Leaves Not Plentiful	Not Feasible
Clay, Plaster	Dissolves in Water	Not Feasible
Clay, Plaster, Carton	Dissolves in Water	Not Feasible
Clay, Plaster, Styrofoam	Brittle, Dissolves in Water	Not Feasible
Clay, Sand, Plaster, Styrofoam	Too Brittle	Not Feasible
Clay, Wax	Melts in the Sun	Not Feasible
Corrugated Vinyl	Unreasonably Many Vinyls Needed, Greenhouse Effect	Not Feasible
Long Carton Strips	Water Trapped Under Roof	Not Feasible
Recy-Blocks	Requires Heat and Pressure	Not Feasible
Ribbed Tetra Pak	Extremely Labor Intensive	Not Feasible
Smog Eating Tiles	Expensive, Heavy, Proprietary	Not Feasible
Vinyl Tarp Under Tetra Pak	Encourages Mold Growth	Not Feasible
Wax Covered Tetra Pak	Melts in the Sun	Not Feasible
Cement, Carton		Recommending
Garden Roof		Recommending
GreenRoof™		Recommending
Vinyl with Carton Hybrid		Recommending

Appendices

APPENDIX F: MATERIAL LIFE CYCLES

Material	Production	Disposal
Tetra Pak	Waste material - not applicable	Incineration or landfill, The carton is mostly biodegradable except for the polyethylene
Polystyrene foam	Waste material - not applicable	Incineration or landfill, product takes a long time to degrade and takes up a lot of room in landfills, very hazardous if burned improperly
Teak sawdust	Waste material - not applicable	Incineration is a common way to dispose of teak sawdust, however it is biodegradable so the problem is not one of the larger problems
Chip bags	Waste material - not applicable	Landfill; most are not biodegradable
Vinyl	Waste material - not applicable	Landfill or incineration, however can be reuse
Plastic bags	Waste material - not applicable	Landfill
Cement	Needs to be mined, fired, and then transported. High emissions	Ground up to be an aggregate or as gravel
Clay	From local area emissions are not significant; not renewable	If not processed becomes earth again
Ceramic	Firing requires heat for long periods of time, some toxic chemicals can be released	Ground up as aggregate or gravel, can also end up back in soil if not contaminated
Plaster	Processed but much lower emissions than cement due to lack of calcination process.	Returned to earth
Asphalt roofing	Very high emissions and many hazardous chemicals released	Landfill
Organic Thatch	No emissions	Biodegradable though sometimes is burned
Bees wax	No emissions	Can be reused or is biodegradable