

# Envisioning a Traffic Solution for Copenhagen

*The following is an executive summary of the team's complete project report. The report is the culmination of research to explore possible tunnel routes to reduce traffic in Central Copenhagen and on the island of Amager. The team prepared this summary for Miljøpunkt Amager and the faculty of the WPI Copenhagen Project Center. For more information, please contact the team at [amagervisioning@wpi.edu](mailto:amagervisioning@wpi.edu).*

*An Interactive Qualifying Project submitted to the faculty of Worcester Polytechnic Institute in partial fulfillment of the requirements for the Degree of Bachelor of Science.*

## **Authors**

Jared Breton

Tanner Buxton

Lucia Shumaker

## **Project Advisors**

Professors Steve Taylor

Robert Kinicki

## **Sponsor**

Miljøpunkt Amager

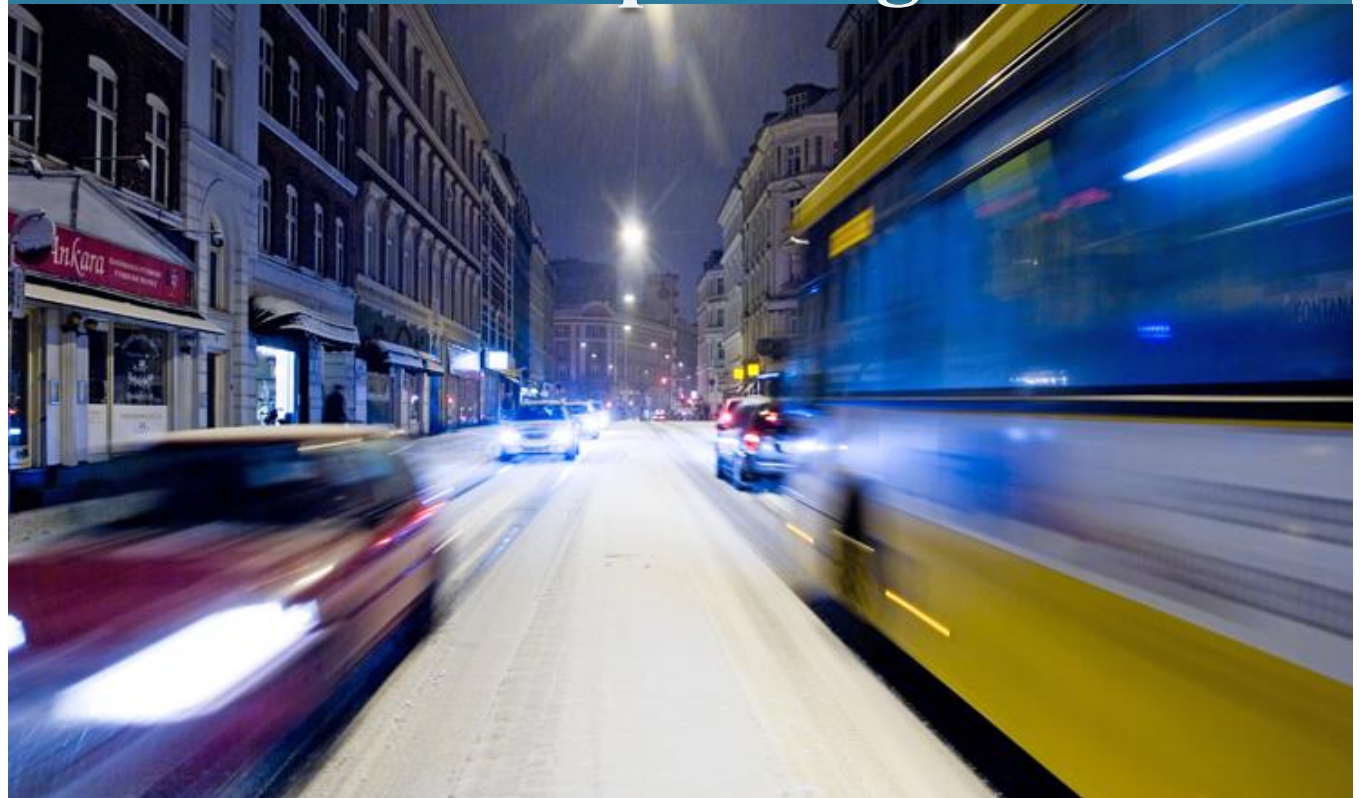

## **ABSTRACT**

Though Copenhagen is trying to set the standards for a green city, thousands of cars clog its main traffic arteries during rush hour on a bi-daily basis. This project provided and evaluated (for Miljøpunkt Amager) a collection of plausible scenarios that focus on reducing motor vehicle congestion in Central Copenhagen, while preserving existing green space. The team conducted interviews, calculated cost and flood capacity, and analyzed traffic models to establish a compelling argument for alternatives to the Eastern Ring Road (E-R) and Ladegårdsåen tunnel proposals. Additionally, the report provides an in-depth discussion of seven tunnel scenarios along with recommendations for a modified combination of the two tunnel routes implemented in conjunction with a congestion charge zone.

## PROBLEM STATEMENT

Throughout the nineteenth century, cities evolved through a process called urbanization. The rapid industrialization of cities caused an increase in people, businesses, and activity. The increasing population brought motor vehicles and traffic congestion. More businesses required the destruction of green space in order to build offices. As cities continuously became busier, air and noise pollution developed. Despite the alluring majesty of urban cities, the living space is unhealthy for residents due to limited green space and more air and noise pollution.

Danes are no strangers to the unhealthy effects of urban living. After World War II, the municipality of Copenhagen realized the need to develop a plan that would guide the development of the city. In 1947, the municipality accepted the Five Finger Plan, which focused on transit-oriented development along five corridors spreading out from the city. Copenhagen has continued to follow this plan by focusing heavily on creating better transit for its citizens and providing access to green space within a reasonable distance of all residences. Currently, noise levels above the EPA safety standard disturb almost half the population of Copenhagen (Københavns Kommune, n.d.). Combined, Copenhageners lose nearly 130,000 hours of work per day sitting in traffic, which results in seven billion DKK in lost earnings (Walsh, 2011, Car Lines). In addition, air pollution is at an unhealthy level of 25% over the EU's limit of 40  $\mu\text{g}/\text{m}^3$  (Københavns Kommune, n.d.). Regardless of the fact that Copenhagen is trying to be 'greener', it still suffers from its industrial nature.

Since vehicles are a major source of air and noise pollution, the municipality recently began discussions of an urban planning strategy that would put vehicles traveling through the city underground. The Big Dig project in Boston, Massachusetts, which moved part

of Interstate 93 into a network of underground tunnels, serves as an example of this approach. This project decreased air and noise pollution by reducing surface traffic congestion in Boston. The Eastern Ring Road (E-R) is the primary plan that the municipality hopes to use in order to reduce traffic. However, part of the E-R is designed to surface in Amager Fælled, a large natural green space close to the center of Copenhagen.

Our sponsor, Miljøpunkt Amager, an environmental points organization, is an advocate for the preservation of green space in Copenhagen, and they view the destruction of Amager Fælled as a negative effect of this solution to traffic congestion. Our purpose was to develop a project that informed the people of Copenhagen of the possibility of alternate solutions. We developed seven tunnel scenarios and evaluated them by their cost, accessibility, ability to preserve green space, and effect on the number of cars using surface roads. The final result was a suggestion of a tunnel that would best suit our sponsor and the municipality of Copenhagen. We also assessed various related aspects, including tolls and servicing harbor developments.

## BACKGROUND

Before working in Copenhagen, Denmark, we studied several aspects of the tunnel that would assist us in developing a method for rating the tunnel scenarios that we planned to create. We felt that current developments in Copenhagen, the increasing traffic congestion problem, flooding due to storm water, the presence of air and noise pollution, and the lack of green space were all important areas of knowledge.

Current developments in Copenhagen included the E-R, the Ladegårdsåen tunnel project (proposed by a WPI IQP team in 2012), and the Ørestad Plan. The E-R and Ladegårdsåen concepts became the basis for the tunnel scenarios we developed. Research on the

Ladegårdsåen concentrated on the route selection and the proposed construction method. Examination of the E-R relied on investigating the exit locations of the tunnel and the public perception of the tunnel. Research on the Ørestad plan fixated on transit-oriented development along Amager Fælled and its relation to the Five Finger Plan.

After looking at "Flood Prevention and Daylighting of Ladegårdsåen", the 2012 IQP that proposed the Ladegårdsåen tunnel, we felt that further research on traffic congestion, pollution, green space, and flood management was necessary.

Traffic congestion is the primary problem. Main points about traffic congestion included the expansion of public transportation, and the cycling culture of Copenhagen. The city's overriding interest was to concentrate through-car traffic on regional roads and avoid through-traffic driving through urban areas. This last principle corresponds to the creation of a tunnel that will avoid going through the urban area by going under it. (Traffic in Copenhagen, 2009).

Studies have shown that both air and noise pollution have significant negative effects. Copenhagen, though not as bad as other cities, is still above the international safety standards. Air pollution is also the result of greenhouse gases, which cause problems on a global scale, in addition to the cardiovascular problems it causes among residents. Noise pollution can cause hearing loss, mental health issues, and increased levels of stress.

Green space has been the last subjected researched. Copenhagen has suffered from a lack of it since before the Five Finger Plan. Green space increases the quality of living for people with access to them while also reducing air and noise pollution created by traffic. The city ruled that there must be a park within a fifteen-minute walking radius from anywhere in the city. We then gathered information on Amager Fælled, the main green space in Amager, to provide

reasoning for the protection of the area and the need to find an alternative to building in the Fælled.

Intelligent urban planning could resolve Copenhagen's various problems, but the team required further supporting research upon arriving in Copenhagen. This research took the form of interviews with experts, and first-hand accounts of living in Copenhagen.

## METHODOLOGY

The goal of this project was to develop and compare--using maps of tunnel routes, traffic models, and decision matrices--several possible tunnel scenarios to alleviate traffic congestion and preserve green space in central Copenhagen and on the island of Amager. To accomplish this, the team addressed the following objectives:

- To gather information and data on current traffic congestion and patterns along H.C. Andersen Boulevard and other heavily trafficked roads in Copenhagen.

- To gather information pertaining to flood management during major rainfall events and the current storm water drainage infrastructure.
- To collect the general opinion of local politicians and residents on aspects of the tunnel that affects the livability of Amager.
- To provide several route options that will attempt to solve storm water and traffic congestion problems on Amager.
- To provide a summary of a comparison between possible tunnel scenarios, including the Eastern Ring Road, using effects on urban green space, traffic congestion, and the general livability of Copenhagen.

We then moved into a phase in which we gathered additional data illuminating aspects of the primary problems. The team worked closely with Anders Jørn Jensen, a consultant who advised the "Flood Prevention and Daylighting of the Ladegårdsåen Canal" IQP in 2012. He provided our team with professional advice and data that supported the analysis of the project, including estimates of how

We retrieved additional data including relevant air and noise pollution data, traffic counts, and development zoning from the website database, The Copenhagen Card.

The team also selected a panel of specialists or experts to interview for additional information. The interviews were semi-structured and informal. We made audio recordings where possible, with the interviewee's permission. The people selected represent some of the interest groups involved in building a viable tunnel proposal in Copenhagen. The groups represented in the interviews were:

- Water management and flooding in Copenhagen
- Politics of large-scale urban traffic projects
- Political activism and community involvement in selecting a traffic solution
- Residential views on major construction

Due to the team's limited time in Copenhagen, we chose to gather information on public opinion by reaching out to people in the community who were knowledgeable about general sentiments. In addition to the key interviews, the team created a public opinion survey to catalogue individual people's opinions and compare these to the material gathered in the interviews. The surveys helped to validate the answers given during the interviews and the interviews balanced the limited sample size achieved in the survey.

The majority of the project focused on the development of new visions for traffic solutions in Copenhagen. The team selected possible routes with guidance from Anders Jensen and created visual aids to communicate these scenarios. The scenarios were named and labeled Scenarios 0-6.

The team evaluated each scenario using a set of standardized criteria that we selected based on

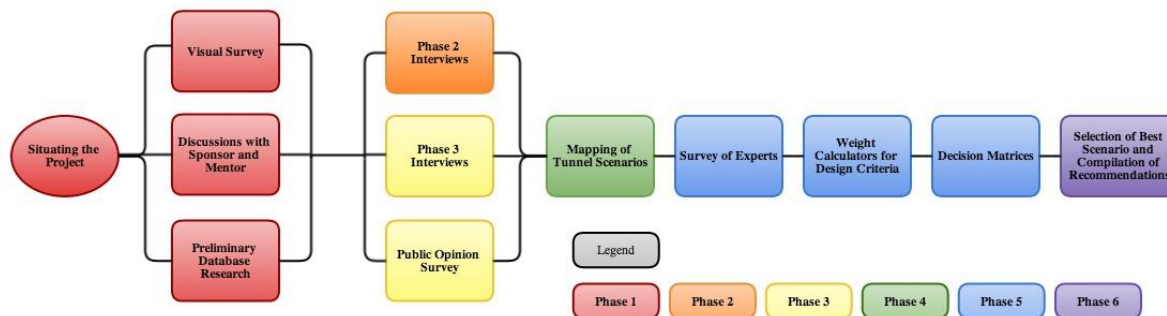

Figure 1 – Methodology Flow Chart (reads left to right)

each tunnel scenario might affect surface traffic.

background research and the information gathered during interviews. These criteria were the amount of traffic removed from surface roads, expected tunnel cost, tunnel accessibility, the tunnel's capacity to mediate flooding due to storm water, and the amount of green space lost after the tunnel was constructed.

We then developed a pairwise comparison and personalized decision matrix for each interviewee that responded to a survey to rank the design criteria (mentioned above) from least to most important. This allowed the team to compare how each interviewee would rank the tunnel scenarios. The personalized decision matrices were used as a representation of how the interest group they represented might view a tunnel project.

The team then created a summary pairwise comparison, based on our understanding of the total project. This understanding was cultivated throughout our time at the project site and was influenced by all the interviews, the public survey, and working with Miljøpunkt Amager. This was important because we were aware that each expert interviewed might have had an agenda that influenced his or her opinions on the topic (of building a traffic tunnel in Copenhagen). However, as outsiders to the community whose only experience with the topic and city were through research and an eight-week stay, the team felt that the decision matrix served as an impartial summary of the project.

The team used the rankings of the tunnel scenarios as both a summary of the relative worth of the scenarios and a method of selecting a scenario to suggest that the Municipality of Copenhagen pursue.

## RESULTS

### Floodwater Management

Our technical mentor, Anders Jørn Jensen, suggested early on that the team use a report called “Østlig Ringvej København” from the Danish Transportministeriet. The report, which later became a leading source of information for our project, details a tunnel cross-section design for the Eastern Ring Road (E-R). The cross section (Figure 2) has two traffic decks, one for each direction of traffic. It also contains space for ventilation, an emergency exit shaft, and four compartments whose use is not specified in the original report.

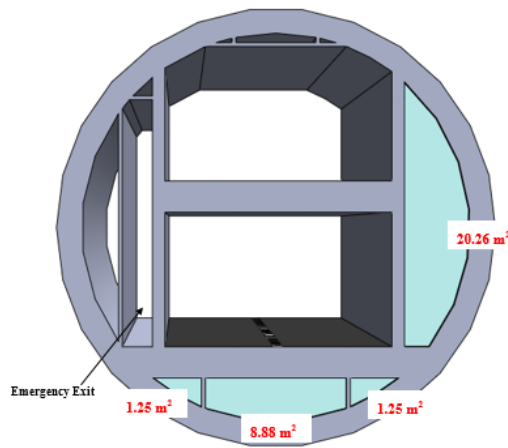

Figure 2 - E-R cross section

Mr. Jensen believed that these four compartments could be employed in the diversion of water from Copenhagen's streets in the event of a massive flooding event. We used the estimated cross section dimensions found in Rambøll's report to calculate the cross-sectional area of these four sections.

We found that the combined area of the sections (without a specified use) is approximately 32.0 square meters and the volume depends on the length of the

tunnel. Thus, a longer tunnel correlates with a larger floodwater holding capacity and a shorter tunnel correlates with a smaller capacity. Despite the range in fluid capacities of the scenarios, all scenarios with tunnels have a theoretical capacity in excess of what was predicted to be necessary.

### Determining Location for Entrances and Exits

After determining the combined cross-sectional area of the water-holding compartments, we determined plausible entrance/exit locations for a tunnel. Because the E-R is designed to surface in Amager Fælled, it will destroy green space, which is a limited resource in modern cities. Because Miljøpunkt Amager is an environmental organization, they are against the destruction of a portion Copenhagen's limited green space.

Instead, we set out to find better locations for tunnel entrances and exits that would minimize the amount of green space damaged by construction. We found the distance needed for construction of entrance/exit ramps (built using a cut and cover construction method) by measuring the distance shown in renderings of the E-R exits produced by Amager Vest Lokaludvalg. We determined these distances using Danmarks Miljøportal online database and found that the distance needed to build an entrance/exit is 300 to 500 meters, depending on how deep the tunnel is and the difficulty of any turns in the tunnel in or near the exit.

We then used The Copenhagen Card online database to check critical areas for concurrent and future building projects (Figure 3). The city had plans that encompassed the eastern portion of Amager Fælled and land extending past Field's shopping center by the E20 European highway. The combination of these plans and eastern Amager's building density makes it difficult to build a tunnel entrance and exit in the area.

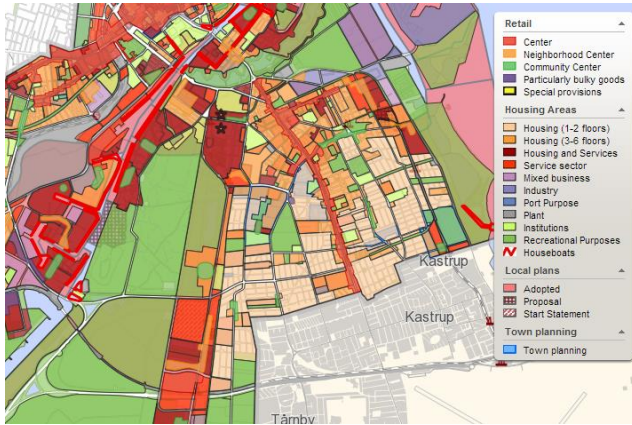

Figure 3 – Zoning map of construction on Amager

Instead, we decided the best option was an interchange directly west of Field's that passes the E20 and loops back to form a connection to the highway. This area has enough space (fits the 300 to 500 meter clearance room needed) and construction of a tunnel should not disrupt any building plans.

### Mapping the Final Routes

The team's final tunnel routes were modified combinations of the E-R and Ladegårdsåen project.

Each of the two original scenarios took years of work by experts in urban planning and engineering, and the routes were selected carefully. However, since we worked for Miljøpunkt Amager, we needed to provide a route that preserves green space while satisfying the citizens of Amager and other districts equally. The culmination of these influences and research led us to develop seven scenarios, based on the Ladegårdsåen, the E-R, or a combination of the two, and some routes incorporated the exit at the E20 west of Field's (Figure 4).

The primary focus when mapping these routes was moving the southern segment of the E-R that previously ran through Amager Fælled.



Scenario #	Description	Compilation
Scenario 1	Eastern Ring Road (E-R)	
Scenario 2	E-R connected to E20	Based on Scenario 1 with different exit
Scenario 3	Ladegårdsåen with E-R exit	
Scenario 4	Ladegårdsåen connected to E20	Based on Scenario 3 with different exit
Scenario 5	Y-Connection to E-R exit	Scenario 1 + Scenario 3
Scenario 6	Y-Connection to E20	Scenario 2 + Scenario 4
Scenario 0	Nothing is done	

Figure 4 – Overview of Tunnel Scenarios

### Implementing a Congestion Ring in Copenhagen

As a way of discouraging commuters from driving through densely populated and narrow roads, many cities implement a congestion charge zone (toll ring). London did just that in 2003 and since its implementation, there is 40 percent less traffic in its city center (Automobile, 2014, London Congestion Charge). The London charge zone provides Copenhagen with a model for properly implementing tolls around the city.

It is easier to implement a congestion ring in Copenhagen (Figure 5) than in London because Copenhagen has geographic barriers like the five

lakes, the harbor, and the ramparts in Christianshavn to place tolls along. The lakes, harbor, and ramparts would force commuters to use the tolls or avoid them completely, which keeps traffic out of the city center. According to Copenhagen's Transportministeriet, a toll charge of 20 DKK per toll would reduce traffic by 50 percent on all toll roads in Copenhagen (Tetraplan, 2013, Transportministeriet-Supplerende trafikanalyser for Østlig Ringvej).

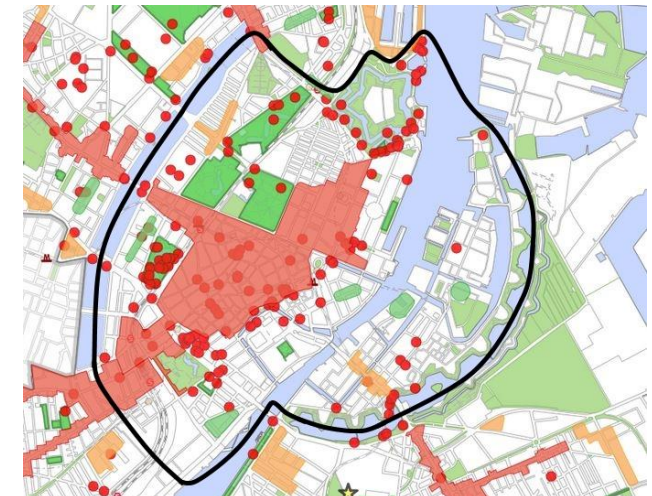

Figure 5 – Proposed congestion ring around Copenhagen's city center

The reduction in traffic, paired with the influx of money that can be used to pay for a traffic tunnel's construction and maintenance alleviates the financial burden the cost of a tunnel places on the city.

### Using Decision Matrices to Evaluate Tunnel Scenarios

As a method of evaluating each tunnel scenario, we sent a form emulating a pairwise comparison chart to each of the experts we interviewed. The form asked each expert to rank a set of evaluation by order of importance. Weighted percentages for each category were calculated using the results of the pairwise comparison chart. After the categories were allotted points on a 100-point scale, the team used a set of

tables to combine the information we had gathered throughout the term from Mr. Jensen, Rambøll, the Transportministeriet, and online research. We created a decision matrix ranking system using the results of these tables to calculate how many of those points each tunnel scenario deserved.

After creating a pairwise comparison and decision matrix for each expert, the team completed its own pairwise comparison to produce a decision matrix that represented the team's understanding of Copenhagen's needs and desires regarding a possible traffic tunnel in the city. The point allocation was as follows:

1. 28.6 points – Reduced # of Surface Cars
2. 23.8 points – Reduced Air & Noise Pollution
3. 19.0 points – Preservation of Green Space
4. 14.3 points – Accessibility
5. 9.5 points – Cost
6. 4.8 points – Floodwater Management Capabilities

We determined that the quantity of cars and pollution reduced are the most important evaluation categories because they alleviate the negative health effects cars have on Copenhagen's residents while also reducing the severity of future traffic problems. Since our sponsor is a Miljøpunkt, we also determined that green space should be ranked third in importance because the city has a limited amount of green space, and preserving what is left is of the utmost importance.

Categories	Calculated Weights	Scenario 0	Scenario 1	Scenario 2	Scenario 3	Scenario 4	Scenario 5	Scenario 6
Cost	9.5	9.5	5.4	4.1	8.2	6.8	2.7	1.4
Accessibility	14.3	3.1	12.2	10.7	9.2	9.2	13.3	13.3
Floodwater Management	4.8	0.7	2.7	3.4	1.4	2.0	4.1	4.8
Reduced # of Surface Cars	28.6	4.1	15.0	15.0	17.7	17.7	28.6	28.6
Reduced Air and Noise Pollution	23.8	3.4	12.5	12.5	14.7	14.7	23.8	23.8
Preservation of Green Space	19.0	19.0	6.8	10.9	15.0	16.3	4.1	9.5
<b>Total</b>	<b>100.0</b>	<b>39.8</b>	<b>54.6</b>	<b>56.5</b>	<b>66.1</b>	<b>66.8</b>	<b>76.5</b>	<b>81.3</b>

Table 1 – Amager Visioning's Decision Matrix

When all of these were considered in the decision matrix, Scenario 6 earned the most points (outlined in red in Table 1). The reason being is that it has the most entrances and exits, so it is more accessible and has the ability to funnel more cars underground, thus reducing more air and noise pollution than any other tunnel design.

Scenario 5 scored second highest but lost to Scenario 6 in large part because it preserves less green space. Scenario 5 uses the original E-R entrance/exit that requires it to run through parts of Amager Fælled, destroying green space in the process.

## CONCLUSIONS

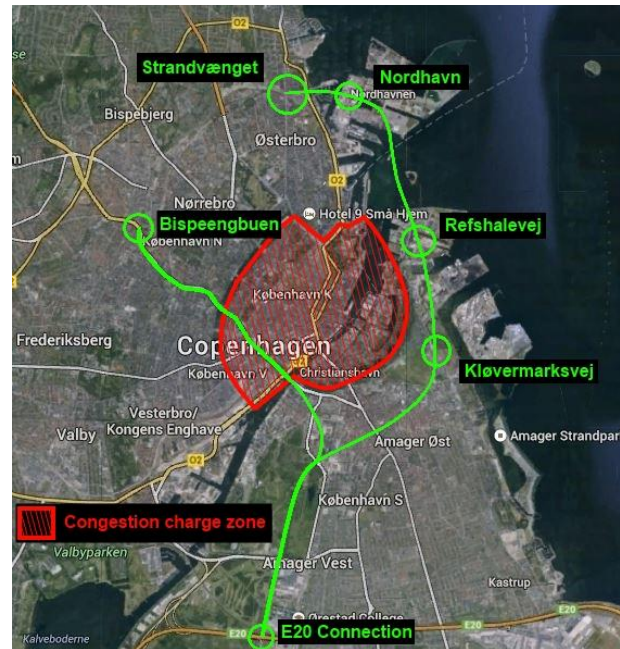

Figure 6 – Scenario 6 (Y-Connection) with implemented Congestion Charge Zone

Copenhagen needs to find and implement a solution to their traffic congestion in the near future, if the city hopes to meet its goal of being carbon neutral by 2025. The selection of a traffic solution is one of the

most crucial decisions the citizens of Copenhagen will make in the next quarter century if they are to solve their traffic congestion problem. Our investigation focused on the analysis of scientific and social research and this report is the culmination of an impartial study of seven plausible solutions. We have provided our sponsor with a preliminary evaluation of the advantages and disadvantages of each scenario to better educate the city's citizens and facilitate constructive discussions on the matter.

We found that Scenario 6, the Y-Connection tunnel with the E20 connection, implemented in conjunction with a congestion charge zone around Copenhagen's city center is the best solution (of the proposed scenarios) for the set of evaluation categories we established.



Figure 7 - Landscape of Amager Fælled

## References

- A/S, T. (2013). Transportministeriet-Supplerende trafikanalyser for Østlig Ringvej Trafikmodelberegninger. <http://www.trm.dk/~media/Files/Publication/2013/Strategiske%20analyser/%C3%98stlig%20ringvej/Trafikmodelberegninger.pdf>: Transportministeriet.
- Ambady, S., Hancock, K., Kohlman, K., & Siegle, M. (2014). *Providing Support For The Ladegårdsåen Daylighting Project*. Worcester Polytechnic Institute.
- Association, A. (2014). London Congestion Charge. *When the scheme operates, who it affects and how you pay it*. 2014, from [https://www.theaa.com/motoring\\_advice/congestion\\_charging/](https://www.theaa.com/motoring_advice/congestion_charging/)
- Kommune, K. Københavnekortet. from City of Copenhagen <http://kbhkort.kk.dk/cbkort>
- Tørsløv, N. (2010, May 2010). Traffic In Copenhagen 2009. 2014, from <https://subsite.kk.dk/sitecore/content/Subsites/CityOfCopenhagen/SubsiteFrontpage/~media/BF3A66B079AB4ACAA6CA167ECF151EB3.ashx>
- Walsh, M. P. (2011). Car Lines. *Car Lines*. 2011 4. 2014, from <http://walshcarlines.com/pdf/nsl20114.pdf>

## Figures

[Cover Photo] – Retrieved on April 30, 2014 from [http://ehp.niehs.nih.gov/pdf-files/2013/Feb/ehp.121-a60\\_508.pdf](http://ehp.niehs.nih.gov/pdf-files/2013/Feb/ehp.121-a60_508.pdf).

## ACKNOWLEDGEMENTS

- Anders Jørn Jensen- Consultant
- Claus Knudsen, Lise Nygaard Christensen, Asger Gad, & Inge Hopps, - Miljøpunkt Amager
- Steve Taylor, PhD; Robert Kinicki, PhD- Advisors
- Lars Weiss- Leader of the Social Democrats, Copenhagen City Hall
- Nis Fink- HOFOR
- Susanne Rasmussen- Amager Vest Lokaludvalg
- Julie Schack