

File Carts for Iron Mountain



A Major Qualifying Project Report

Submitted to the Faculty of the

Worcester Polytechnic Institute

in partial fulfillment of the requirements for the

Degree of Bachelor of Science

By

Matt Nichols

Rory Moulton

Josh Osgood

Matthew Cook

Sean Waithe

Date: April 22, 2008

Sponsoring Organization:
Iron Mountain

Project Liaison:
Ted Sisson

Project Advisor:

Professor Richard Sisson



This report represents the work of one or more WPI undergraduate students submitted to the faculty as evidence of completion of a degree requirement. WPI routinely publishes these reports on its web site without editorial or peer review.

Abstract

Iron Mountain is a records storage company that deals with storage and transportation of paper files on a daily basis. Their current method of file transport lacks durability and ease of use. Our project resulted in a functional prototype that optimized reliability, mobility, stability, cost, and safety.

Contents

Abstract.....	ii
Contents	iii
List of Figures.....	iv
1.0 Introduction.....	1
2.0 Background Research	3
2.1 Online Research.....	3
2.2 Patent Research.....	5
2.3 Real World Research	9
3.0 Methodology.....	17
4.0 Results and Analysis.....	23
4.1 Building.....	23
4.2 Testing.....	26
4.3 Results.....	29
4.4 Analysis.....	32
5.0 Conclusion	36
References.....	37
Appendix A.....	38
Material Stress Analysis	38
Appendix B.....	39
Static Displacement Photographs	39
Glass .125 inch thick sheet displacement	39
Glass .25 inch sheet displacement	40
Glass .375 inch sheet displacement	41
Glass .5 inch sheet displacement	42
PVC .125 inch sheet displacement.....	43
PVC .25 inch sheet displacement.....	44
PVC .375 inch sheet displacement.....	45
PVC .5 inch sheet displacement.....	46
Titanium .125 inch sheet displacement.....	47
Titanium .25 inch sheet displacement.....	48
Titanium .375 inch sheet displacement.....	49
Titanium .5 inch sheet displacement.....	50
AISI 304 Steel .125 inch sheet displacement.....	51
AISI 304 Steel .25 inch sheet displacement.....	52
AISI 304 Steel .375 inch sheet displacement.....	53
AISI 304 Steel .5 inch sheet displacement.....	54
Aluminum 1060 Alloy .125 inch sheet displacement.....	55
Aluminum 1060 Alloy .25 inch sheet displacement.....	56
Aluminum 1060 Alloy .375 inch sheet displacement.....	57
Aluminum 1060 Alloy .5 inch sheet displacement.....	58
Wood .125 in sheet displacement	59
Wood .25 in sheet displacement	60
Wood .375 in sheet displacement	61
Wood .5 in sheet displacement	62

List of Figures

Figure 1: Folding Storage Truck.....	3
Figure 2: Nest Away Folding Truck.....	4
Figure 3: Collapsible Cart with Shelf	6
Figure 4: Modular Container/Bookshelf Moving Cart	7
Figure 5: Bookcase and Storage Unit	8
Figure 6: Interlocking Bookrack.....	9
Figure 7: Book Trolley (from Gordon Library).....	9
Figure 8: Laptop Cart (from Gordon Library)	10
Figure 9: Laptop Cart (from the Bancroft School)	10
Figure 10: Projector/ TV Cart (from Bancroft School)	11
Figure 11: Overhead Projector Cart (from Bancroft School)	11
Figure 12: Lego Robotics Cart (from Bancroft School)	12
Figure 13: 4 Shelf Cart (from Borders).....	12
Figure 14: 5-Shelf Display Stand (from Borders).....	13
Figure 15: Book Trolley (from Walden Books)	13
Figure 16: 4-Shelf Storage Cart (from Sear's).....	14
Figure 17: Tool Storage Chest (from Sear's).....	14
Figure 18: Adjustable Height Display Cart (from Sear's)	15
Figure 19: Dolly (from Sear's)	15

1.0 Introduction

Iron Mountain was founded in 1951 and is the worldwide leader in records management. They reduce the cost and risk of records storage for over one hundred thousand companies throughout North America, Europe, Latin America, and the Pacific Rim. Iron Mountain provides services such as records management, data protection, and information destruction. Additionally, they offer expertise in addressing storage costs, litigation, regulatory compliance, and disaster recovery.

Records Management is very important for today's businesses. This is because industry is generating a lot of information both in paper and digital form. It is very difficult to implement a legal program that can help with this sort of management. Iron Mountain addresses these challenges and provides reduced costs and risks, while improving accessibility to the information.

Another important aspect of business today is Data Protection. It has become more and more difficult over the years to protect your private information because the growth of technology creates more complexity and more challenges. Iron Mountain offers cost effective solutions that protect against natural disasters, human error, viruses, and security breaches. Iron Mountain works to ensure that the companies they provide services for are securely protected and Iron Mountain makes possible rapid data recovery if needed.

Information Destruction is another important feature of business today. Many businesses today need to safeguard sensitive information as well as protect proprietary information and intellectual property from being stolen. One way to reduce these risks involves information destruction. Iron Mountain provides this service for both paper and

digital information. They provide secure shredding of paper records along with the capability to automatically destroy data on lost or stolen laptops. Iron Mountain knows how important it is to protect information in this day and age and provides services that will deliver cost effective and innovative solutions to reduce exposure risks.

Iron Mountain has over 264 million cubic feet of paper storage. Many of these files need to be found and transported to companies all over the world. In doing so, the paper needs to be transported safely and efficiently. Currently, wooden carts are used to transport files around the warehouse as well as between warehouses. These wooden carts have many flaws and need to be improved for more efficient and safer transportation. The carts that are currently used are unstable, difficult to maneuver, have no handles, and do not last very long. These are just a few of the problems with the current cart situation. The goal of this project is to design a mobile records storage cart that will fix these problems and meet the customer needs. Some of the customer needs include good maneuverability, different shelf configurations, collapsibility, durability, and safe to transport.

2.0 Background Research

In order for us to develop a quality cart for Iron Mountain we needed to research what cart designs are currently on the market. This section describes our research both online and out in the field. We researched companies online that sell carts used for file transportation to determine the cost and effectiveness of each cart. Additionally, we performed research through the United States Patent Office (www.uspto.gov) to find carts that have been patented. We found many different carts through the patent website and we described them in this section. Furthermore, we went out in the field to find possible carts that we could either use or take certain features from. The carts found in the field range from carts used in schools to carts used in industry. All of the carts were analyzed to determine the benefits and drawbacks of each. This section describes our research performed prior to the assembly of our own cart.

2.1 Online Research



Figure 1: Folding Storage Truck

The above style of folding storage truck is manufactured by Global Equipment Company, Inc. in Buford, Georgia. The truck is made of 16-gauge stainless steel, which

is strong enough to give the cart an overall capacity of 1200 lbs. The signature feature of this design is the truck's ability to fold one of its sides in, forming an L-shape that can be stored while taking up significantly less floor space than when open. The truck in the open and closed positions is shown to the right. When open, the device has a 32x43" footprint and is 67" tall. For mobility, the cart relies on two swivel casters and two rigid casters, all six inches in diameter at each of the corners. An optional second shelf is also available that is removable and sits on the truck's cross members for additional storage capacity (www.globalindustrial.com).¹



Figure 2: Nest Away Folding Truck

The folding truck pictured above is manufactured by the same company that makes the nest away model described above. Although the designs are similar, the fully folding shelf truck holds the clear edge as far as convenience and load capacity. This model is made with 1x1" square steel tubing which allows the device to carry 2000 lbs. In addition to the higher load rating, this model also allows the user to fold up both sides of the shelf, allowing it to collapse to less than 6.5" wide when empty. If desired, the shelf can also fold in the same fashion as the "nest away" model, with one side still open.

¹

<http://www.globalindustrial.com/gcs/product/productInfo.web?&infoParam.itemKey=30013779&infoParam.picGroupKey=1921>

The device uses spring loaded latches to safely secure the shelf in either the open or the closed position. Unlike the “nest away” model above, this truck features four upgraded 6” polyurethane swivel casters with two locking wheels. The truck also features tilted shelves to keep loads on the truck while moving (www.globalindustrial.com).²

2.2 Patent Research

There are many different types of carts that have been patented over the last thirty years. Carts have been made to transport books, files, bread, soda, other food, computers, etc. There are many different designs and specific uses for each one. For this report, carts able to transport books, files and some food were researched. All of the following patents are available through <http://patft.uspto.gov/netahtml/PTO/srchnum.htm> when the patent number is inserted in the search bar.

This Collapsible Cart with Shelf (Patent # 6,540,249) was patented in April, 2003 by David King. It is used to hold books, files, and other items on both sides of the cart. The cart is on wheels so it is transportable to a certain extent. The wheels are small, so the cart is capable of moving on hard, flat surfaces and may have some difficulty when maneuvered outside on pavement. The shelves on this cart are collapsible so that the cart can be folded up when not in use. When completely collapsed, all of the shelves and the side walls close flat against middle of the cart. The cart is very maneuverable even when it is folded up because the wheels are far enough apart to maintain balance and control. This cart design is capable of supporting large amounts of weight as well. Below is a picture of the cart from an offset angle.

²

<http://www.globalindustrial.com/gcs/product/productInfo.web?&infoParam.itemKey=30047524&infoParam.picGroupKey=486>

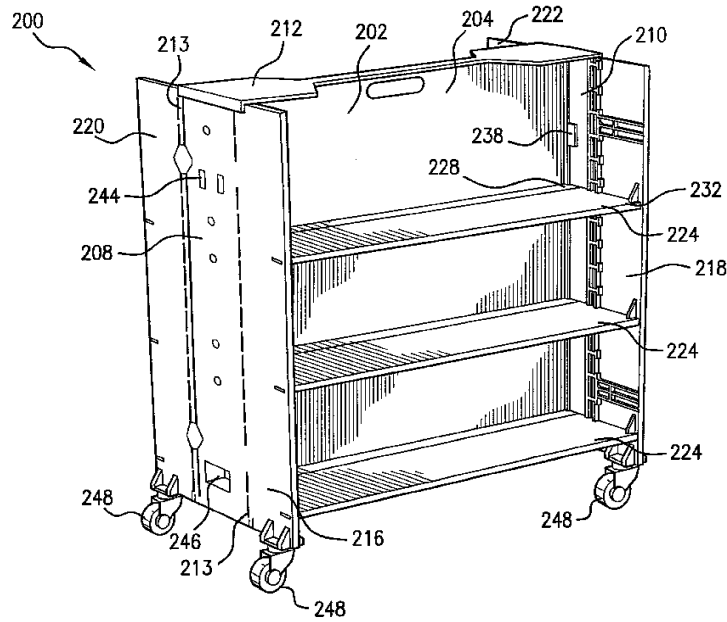

Figure 3: Collapsible Cart with Shelf

This Modular Container/Bookshelf Moving Cart (Patent #6,460,950) was patented by Christopher and Richard Spitzer in October, 2002. This cart is used to transport any number of different items including books, computers, paper products, etc. It is separated into four easily removable and attachable sections. Each section is two shelves high and can have a back or not. The sections can be stacked in different configurations using two, three, or four sections. The sections can be aligned either upright or on its back. When on its back, the sections act like containers instead of shelves. This cart is transportable on the rectangular base. It was designed for warehousing computers and files as well as relocating office supplies. The sections can be interchangeable very easily to accommodate moving different materials. This design is useful if multiple configurations are needed, such as only needing two shelves to carry equipment. If there is little equipment to move, extra shelves can be removed to cut down on weight and size.

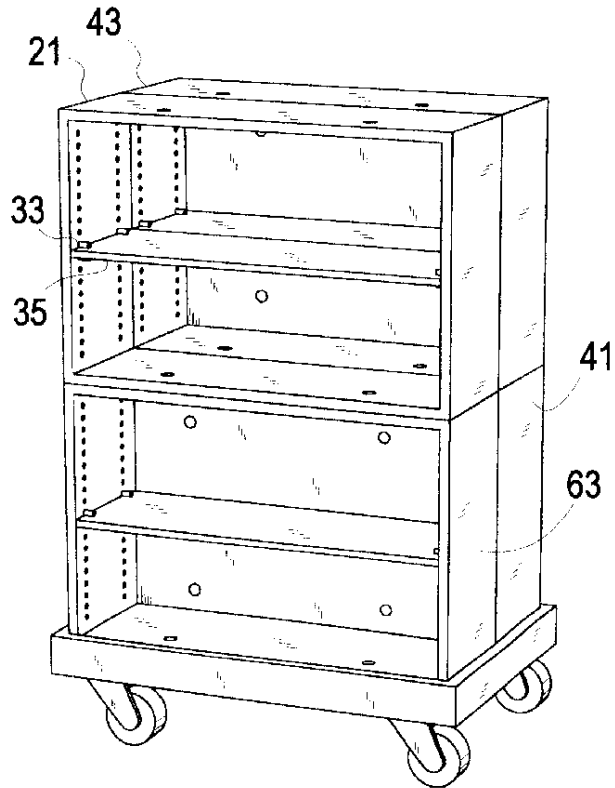

Figure 4: Modular Container/Bookshelf Moving Cart

This Bookcase and Storage Unit (Patent #7,182,415) is used to hold paper products. This unit was patented by Takahiro Yamada in February, 2007. This storage unit is broken into several different sections that each has a latch so they can be attached. The sections are easily stackable and interconnect on the outer surface of the side panels. This design allows for using different configurations based on the amount of material being stored or transported. There can be as many or as few sections as desired by the user as long as there is enough space in the storage area. This design is very durable and stable. It can be transported easily, but it does not come on wheels. When needed to be transported, the unit needs to be carried as is, or it can be broken down for easier transportability. This unit can be put together very easily using very few number of fasteners.

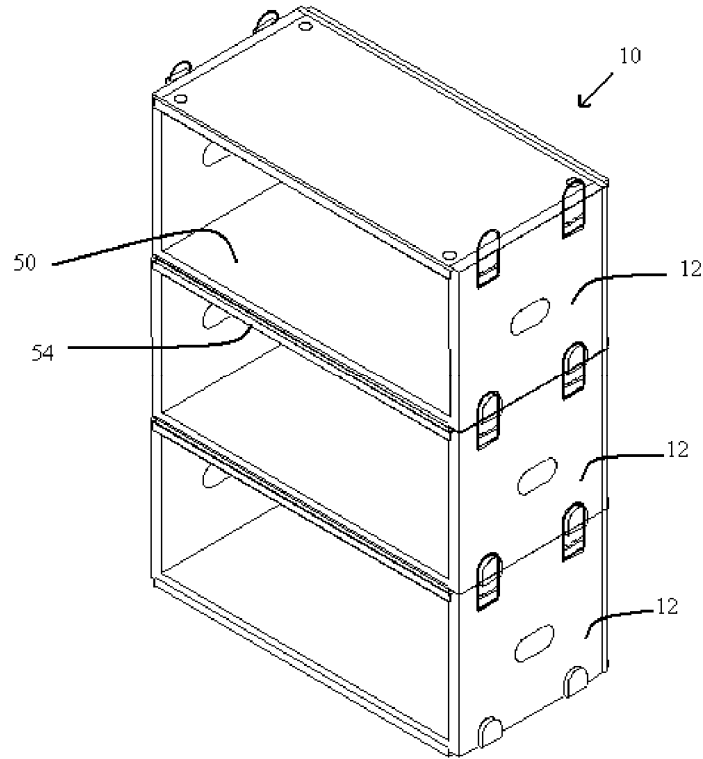

Figure 5: Bookcase and Storage Unit

In researching for transportable bookshelves, a patent for an Interlocking Bookrack came up. This patent was created by Kenneth Gold in June, 1986. The reason for investigating this patent is because of the interlocking design. This bookshelf was designed to hold both hard and soft cover books of varying sizes. It is used to support the books and magazines in an upright position. The shelf is normally placed on a desk, but can also be placed inside of an existing bookcase. The shelves are constructed from sheet metal and can be assembled without the use of hardware. The shelving is very durable and lasts a very long time. The shelves are all interlocking for easy assembly and come in a variety of sizes and widths.

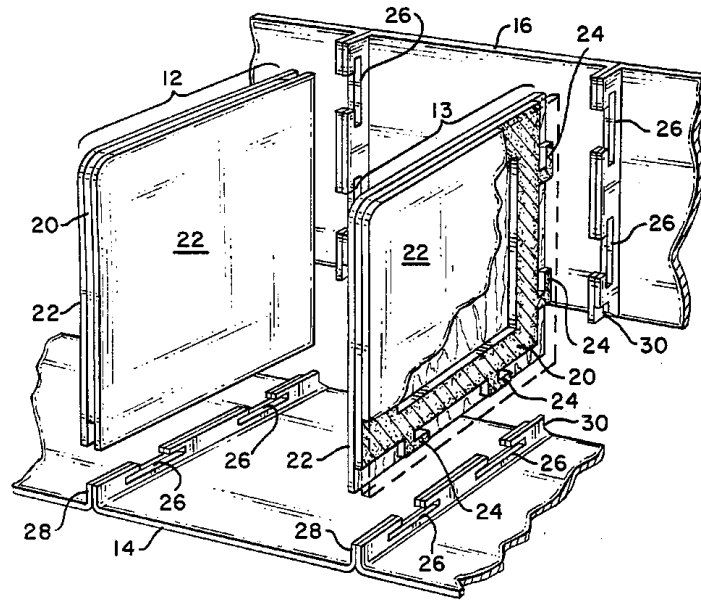

Figure 6: Interlocking Bookrack

2.3 Real World Research

The following carts were found out doing field research in the real world. We went out and took several pictures of existing carts to see if there was anything that could be used for our design, or what to improve upon. After the pictures were taken the next step was to point out the strengths and weaknesses of each of the carts, to ensure that the most information could be gained from each individual cart.



Figure 7: Book Trolley (from Gordon Library)

The cart pictured below had sides that were protected so that there would be no sharp edges to injure the user and also had hand grips that allowed for easy pushing and

pulling; very simplistic to move. On the other hand this cart could only be used to moving a small amount of weight, which is something that would have to be scaled up for our design.



Figure 8: Laptop Cart (from Gordon Library)

This cart is a great example of a sturdy compartmentalized cart that was similar in fashion to Iron Mountain's X-Ray cart. Also, there were doors on this cart that allowed for the openings to be covered for more security. More so, the casters had the ability to lock which would be very useful if the cart was on a hill, where, for the users' safety, the cart would need to remain stationary. When the maneuverability of the cart was taken into consideration it was found that the cart was rather bulky.



Figure 9: Laptop Cart (from the Bancroft School)

This cart had most of the same characteristics as the previous laptop cart from the Gordon Library, but in this case the cart has larger handles that make it simpler to grab

hold of the cart. Unfortunately, the maneuverability is still rather bad for this laptop cart just as it was for the previous one.



Figure 10: Projector/ TV Cart (from Bancroft School)

This cart did have locking casters, but that was the extent of the benefits, due to its tall height and small surface area this cart is rather inept for the movement of anything larger than a projector, but also has the ability to tip over to easily.

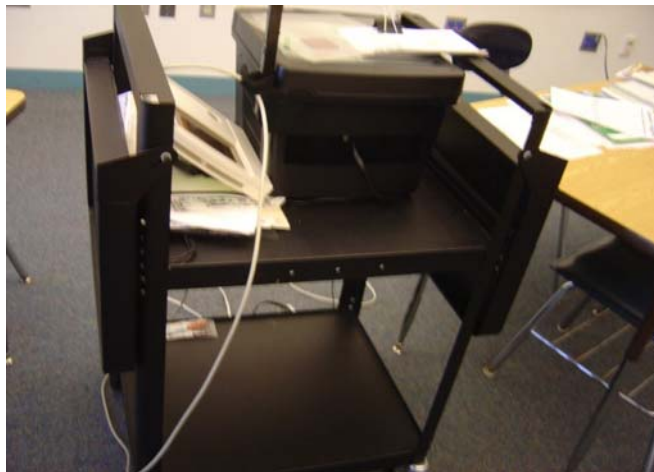

Figure 11: Overhead Projector Cart (from Bancroft School)

Unlike the other carts so far, this cart had collapsible shelves that would be able to create a larger surface area to work on, but when collapsed they would take up very little space. Also this cart was rather sturdy, but when the shelves were collapsed it had little usable surface area.



Figure 12: Lego Robotics Cart (from Bancroft School)

The front face on this cart has the ability to close and lock to secure the objects contained on its four internal shelves, which made this a very secure cart. Once again though, this cart had poor maneuverability, but even worse it had minimal ground clearance. This minimal ground clearance would make for very poor travel over the grated floors in the warehouse.



Figure 13: 4 Shelf Cart (from Borders)

This cart is optimized to store and display as many books as it can, which is along the same ideas of what is needed for Iron Mountains file transfer carts. Although the

storage capacity was good, it was not achieved without creating a tall cart with a high center of gravity, which would not be safe for long distance file movement.



Figure 14: 5-Shelf Display Stand (from Borders)

Stability and storage are the best traits of this cart, but these were both achieved by making the cart stationary. A stationary cart would be not very good at file movement, so this is a big drawback of this idea.



Figure 15: Book Trolley (from Walden Books)

The double sided feature of this cart would allow two people to access the items at one time, which along with its narrow size made this cart optimal for narrow aisle usage. This is very applicable in terms of Iron Mountain's usage due to the storage aisles

constantly narrowing to allow for more files to be stored in less warehouse space. Again this cart is not secure due to the fact that there is no way to lock any of the books/ files in.



Figure 16: 4-Shelf Storage Cart (from Sear's)

The sheer height of this cart and light weight build made this an unstable cart to push around when loaded, but it did provide a great deal of storage when it was stationary.



Figure 17: Tool Storage Chest (from Sear's)

The Tool Chest is a very secure, very sturdy, compartmentalized cart, but the files would have to be placed on their side. This would not be the ideal way to place the

files due to the chance that the files may mix with each other. Also, the cart was not very maneuverable and was rather heavy in weight.



Figure 18: Adjustable Height Display Cart (from Sear's)

Even though this cart did not have great mobility, it did have the ability to have adjustable shelf heights. These adjustable shelves would allow for great customization to go from task to task, be it X-rays or files.



Figure 19: Dolly (from Sear's)

This cart allows for easy movement, fork lift capability, and was also very stable side to side. It could also move boxes, which files could be placed in first. This method would be both safe and secure.

After the benchmarking was completed it was noted that the most important ideas to keep in mind were stability, mobility, security, capacity, and cost. The best ideas gathered were that the cart should maintain a lower center of gravity as to not tip over on the user. Also, locking casters that provided enough ground clearance were also rather important. Finally, storage space is a necessity to make the file transfer process more efficient.

3.0 Methodology

Our goal for this project was to improve upon the mobile cart design currently used to transport files within Iron Mountain's warehouse along with transporting files between their clients. Their current cart design lacked many features they wanted to have in a file cart. Additionally, the cart used did not have a long useful life. We set out to improve upon their cart design by adding features that they wanted implemented.

To start off our research we did some benchmarking of existing cart designs to determine if anything currently existed that could be used. We also wanted to get ideas from different types of carts to see what features would be best to use for our design. We looked at all different types of carts with many different uses as described in the previous chapter. Once we finished researching cart designs that are available on the market today, we met with our sponsor to find out about their old cart design as well as what elements they want on their new cart.

When we met with Iron Mountain, they showed us their current cart situation. They gave us a list of reasons for wanting a new cart design. Their old carts were unstable, gave employees splinters, had no handles, were difficult to maneuver, took up a lot of space in the trucks, and were too big to fit down the aisles of the warehouse. These are not the only problems, but rather the main points they wanted us to focus on. We then discussed with them what features they wanted us to use for the new cart design. These features included locking wheels, multiple shelf configurations, collapsible and separable for transportation, creating a train of carts, a security cover, and handles. Using the list of problems with the current cart and the features they wanted to implement to the new cart we started brainstorming ideas.

After meeting with Iron Mountain we started to focus on the design process in more detail. In creating a design process we had to identify a need of the project. In doing so we decided that the need of the cart was to transport files from one area to another. This need was defined by Iron Mountain because they transport so many files. They needed to use carts to transport files within their warehouse in order to bring files to computers to input them into their system. They also need to take the files from storage in the warehouse and deliver them to the client as needed. Iron Mountain transports thousands of files on a daily basis, so it is important that they have a functional cart.

The next step in the design process includes defining the problem. The current problems with the cart are difficulty to maneuver, unsafe, lacked handles, and could not be collapsed or taken apart. The reason the carts are difficult to maneuver is because they currently have four wheels that are not very large. They need to be able to move the cart over many different types of surfaces including, but not limited to, concrete, carpet, tile, and hardwood. It is important that the new design can fix this problem. The current carts were unsafe because if a wheel broke off the cart was rendered completely useless. Iron Mountain told us that this was a problem, so again it stresses the importance of sturdy wheels. The carts lacked handles which also contributed to the difficulty to maneuver. Lastly, the cart could not be collapsed or taken apart. Iron Mountain wanted to be able to reduce wasted space of carts that were not being used, as well as be able to transport more empty carts in a truck. Sometimes it is needed for empty carts to be transported to a new location, but there is a limit to the number of carts that can fit in a truck. If the carts could be collapsed so more could fit, or taken apart to stack to the full height of the truck

that would be very helpful. Also, storing empty carts in the warehouse takes up valuable space. These were the main problems Iron Mountain had with their cart design.

After we determined the problems with the cart we started to conduct research on how to fix the above mentioned problems. In doing so we researched carts from many different backgrounds and uses. We found carts that are used for holding books, files, bread, soda, and many others just to get a broad range of carts used in the world today. A more in depth analysis of our research is located in the previous section (Background Research).

After doing the background research we narrowed our search for the next design step. We picked and chose features from all different types of carts and presented our findings to Iron Mountain. We came up with many different design ideas to present to Iron Mountain. Our first design concepts were out of the box ideas. One idea was to have a cart that is inflatable. This design is beneficial because it can collapse into almost nothing. There would be durability, strength, and stability concerns though. Another design was to have the cart be able to tilt at an angle. This would increase stability, would hold the files in the cart, and could fold upright for when being stored. The next two designs involved folding the cart. The first idea was to have the cart be able to fold horizontally. This means that when facing the front of the cart, you could take the back section out and each corner of the cart is hinged so the cart could collapse to only a few inches high. Another idea involved having the cart fold vertically. The way this idea would work is if all the shelves are removable, and when looking at it from the top view the cart would fold into only a few inches deep. Lastly, we came up with a design to have the cart stackable. This way each shelf is a separate unit that can be stacked and

attached. This way, there would only need to be as many shelves as files needed instead of having a cart with a specific number of shelves. When transporting empty, you can stack the shelves as high as will fit in the truck. This brought us to our next design step, analyzing the criteria.

We got feedback from Iron Mountain as to what design ideas they liked and which ones they didn't like. They did not like the inflatable cart idea because they did not think it would work very well. They did not think the cart would be able to support much weight and felt that it would break or pop easily. They did not like the tilt idea either because they thought it would be too difficult to have the cart tilt when loaded with files. Additionally, they had problems with both folding cart ideas as well. They did not like the idea of having so many moving parts because if something failed, it would be difficult to keep the cart together. They also had concerns that their clients might not be able to work the folding cart. They did however really like the stacking idea. They thought we could really come up with a good design that involved stacking carts. So from all of Iron Mountain's feedback we decided to move forward with the stackable idea and scrap the other ideas.

The next step in the design process is to find alternative solutions. We collected all of the feedback and started to find more solutions using the aspects of the cart that Iron Mountain wanted us to use. We wanted to build on our idea of the stackable cart. There had to be some sort of male to female connection on the top of the cart and the bottom the cart as to keep the shelves from sliding off of each other. We also decided to implement handles on the side of the cart similar to handles of a bureau. When hanging, the handles are almost flush with the side of the cart, but when held they move as needed.

Additionally, Iron Mountain wanted to be able to protect the files from outside viewers so they wanted some sort of security cover. After researching, we found a company that makes custom covers, similar to grills covers but with a drawstring on the bottom. We could have the covers made to our specified dimensions to keep the files out of view. We decided to use four wheels on our design, but we got more sturdy wheels than Iron Mountain originally had. Once we completed this design, we met with Iron Mountain to get more feedback and analysis for the next design step.

They had a lot of advice on our design. They did not like our choice for handles because they felt that their employees could pinch themselves easily on the moving handles. They preferred that we have some sort of indented handles. They also wanted us to incorporate using six wheels instead of four. This would allow for better maneuverability, stability, and in the case that a wheel breaks off there would still be five wheels so the cart wouldn't completely lose functionality. Additionally, they wanted a more secure cover. They felt that the cover would not be very helpful and is too hard to keep track of. We brainstormed and came up with a solution of having a sliding door on the front.

Following our process of finding more solutions we had to again analyze these solutions for the next design step. Once we analyzed each feature we came up with a final design. Our final design implemented all of the above mentioned features, because after the analysis they were all deemed feasible. The design was stackable and was kept in place by indents in the bottom of the shelf and protrusions in the top of the shelf. Additionally, to ensure the shelves wouldn't come apart, each shelf was fastened together by latches on each side. We found indented handles that we implemented into the design

as well that will not harm employees. As for the wheels, we gave the cart six wheels that could all swivel. The four wheels on the corners had the ability to lock both the swivel and the wheel, while the two interior wheels would not lock. Having the four corners lock allowed for the cart to be locked in place regardless of which side the employee was pushing from. Locking only two wheels is enough to keep the cart from moving. The six wheels were aligned so that a fork lift could pick up the cart if necessary. In regards to the security of the cart, we used the sliding security panel on the front. In addition to the slot to secure the contents of the cart, we also placed grooves on the back of the cart as a storage area for the cover when it is not securing the files.

4.0 Results and Analysis

The main goal of this project was to create a cart that was able to perform all necessary tasks as requested by Iron Mountain. The following section describes our process of building which includes how we constructed the various prototypes. Testing is another area described in the following section which includes interchangeability, stress analysis, and mobility. Additionally, there are results regarding the testing data. There is an overview of our analysis.

4.1 Building

Construction of the first, wooden prototype took approximately three and a half hours for a team of four people to build. Of this time, about an hour and a half was dedicated to making measurements and cutting pieces to size. An hour was spent determining proper methods to affix the pieces and assembling the cart. The final hour was used to perform finishing operations such as sanding and reaffixing parts that did not meet specifications. This prototype consisted of five-sided, cubby boxes with holes cut in the sides for handles, four circular holes cut through the bottom which would rest on four circular holes protruding from the top of the box below, and a sliding security cover made of cardboard. There were also removable, pressure fitted dividers placed in one of the cubbies. These boxes were supported by a separate base with four casters on the bottom and four circular holes on the top. This model was built using one-half inch plywood, four swivel casters and one, two and two and one-half inch drywall screws. Boards were affixed to each other via butt-joints.

Based on feedback from Iron Mountain this prototype was adjusted to meet their concerns. Iron Mountain wanted to have all holes removed from the five, closed sides of

the box. To do this, the two sides with the handles on each box were removed and a new sheet of one-half inch plywood was screwed into place. Plywood handles of dimension 4"x1"x1" were attached to the new sides of the cubby boxes using one and one-half inch drywall screws. A surface coat of light blue paint was added to reduce surface wear and make the cart more aesthetically pleasing.

At the request of Iron Mountain, a full scale, functional prototype was constructed. This final prototype was made using two 8'x4' pieces of 3/4" plywood, one 8'x4' piece of luaun, three separate pairs of handles, four locking swivel casters, three pairs of latches, two non-locking swivel casters, and drywall and wood screws. The interior dimensions of the finished boxes are 33"x14 1/4"x14". Each box was constructed using two 36"x16" sections of 3/4" plywood, two 14 1/4"x14" side-pieces of 3/4" plywood, one 36"x14" back-piece of 3/4" plywood and two handles. The two 36"x16" boards were then given two 36"x 1/4" grooves placed 1/4" in from both 36" length edges, on the same side of the board. The grooved boards were turned such that the grooved sides of the board faced each other then the sides and back were affixed using 1 1/2" drywall screws such that the edges which would contain the handles were flush and the top and bottom pieces protrude 1/2" in both the front and back. A hole-saw was used to cut four 2" diameter holes into the bottom of the box to make the holes that would sit on the piece below it when stacked. The four pieces of wood removed in this process were affixed to the top of the box, using 1 1/4" drywall screws, in the same location as they were removed from the bottom to create the parts which would prevent side to side movement of the boxes when stacked. Rectangular holes were then cut into the side of each box where the recessed handles were fitted and screwed into place using 1/2" brass, wood screws. To

finish the box, a piece of 33"x14¼" luaun was screwed into the interior bottom of the box to cover the four holes created by the hole-saw. A 36"x14¼" piece of luaun was then cut and inserted into the front grooves of the box as a security cover. This piece could also be placed in the grooved section which protrudes from the back of the box. Three cubby-boxes were made in this same fashion. One of these boxes was fitted with two 14"x14", ½" plywood dividers that separate the box into 3 equal sections and were screwed in using 1 ½" drywall screws.

To build the base that the boxes would rest on required two 36"x16" pieces of ¾" plywood, six 4"x 3½" pieces of ¾" plywood, four 1-7/8" diameter cylinders of ¾" plywood, four locking swivel casters and two non-locking swivel casters. The two large sections of plywood were fastened together with 1½" drywall screws to create a 36"x16"x1½" base for the board. The four cylinders were screwed to one side of the base to fit into the bottom of a box placed on it. Using 1¼" drywall screws four of the 4"x 3½" pieces were screwed into the other side of the base so that one 4" side was lined up with the 36" edge of the base and one 3½" side was lined up with the 16" edge of the base. The remaining two 4"x 3½" pieces were placed at the midpoint of the 36" edge such that one 4" edge was flush with the edge of the base. The four locking casters were centered on the corner 4"x3½" pieces and fastened using four 2" screws per caster. The two non-locking casters were affixed in a similar manner on the two pieces in the middle of the 36" edges of the base.

The three boxes were then stacked on top of each other on the base. Latches were then affixed to sides of the unit to hold the cubby-boxes and base together, preventing up and down movement which may result in separation of the parts. The latching part of the

latch mechanisms were placed approximately at the midpoint of the top edge of the sides and the part to which this part latches was placed at the same point on the bottom edge of the side. The latches were then used to secure all the parts together, completing the full-size prototype of Iron Mountain's new file transport cart.

4.2 Testing

The basic functionality of the cart was tested first. This included testing stack ability and ease of sliding the security covers.

To test the stacking we arranged the three boxes in all six possible stacking combinations to make sure that the stacking was interchangeable. The latches were tested in every variation to make sure they were lined up to function properly in any arrangement. During this test, the ease of changing arrangements was also examined. To do this between one and four people employed various different methods of interchanging the cubby carts. The first method was to use one person to lift off the top box and set it aside then pick up the next box which was also set aside. The former box would then be placed in the spot of the latter box and the latter box would be placed on top of the former, thereby switching their positions. The next method was to use two people to switch the position of two segments of the cart. The first way this was tried was to have one person lift the upper level and hold that while the other person lifted the box beneath and hold it while the first person placed the box in the spot below the one that it formerly occupied. The other box was then placed on top of the box it used to support. After this, the simultaneous, stationary switching of two boxes using two people was examined. To perform this test, two people were standing at either end of the cart where they would each grab a handle on the same end of the two carts to be switched. Each

person, using one arm, would lift the top box up and to the side then, with their other arm, lift the bottom box up and to the opposite side. The first box was then placed on the bottom and the second was rested on the top. Testing using three and four people was done using variations of those used during one and two person interchangeability testing. Three people were used to test changing two and three boxes at a time. To change two boxes one person lifted the top box while the other two people lifted the lower box and the positions of the two boxes were then changed. To change the situation of three boxes, one person lifted one box off the top while the other two people used the two person simultaneous, stationary switching method to rearrange the orientation of the boxes. Finally, four people were used to test the changing of two and three boxes. To change two boxes, two people were situated at either end of the cart. One person from both ends would lift off the top box and the second pair of people would lift the bottom one off and the two would be switched in placement. The other four person method tested was to have two people perform the simultaneous, stationary switching method while the other two lifted the bottom box and placed it on top.

Next, the ease of sliding the luaun security covers was tested. To do this, each cover was slid into both the front and back of its corresponding box. After that the covers were tested in the other boxes to make sure that the covers were interchangeable between boxes. This test was particularly important due to the fact that the proposed method of cart linking was to extend the security covers of two separate carts so that they would be half in one cart and half in the adjacent, linked cart.

The next test to perform was the weight limitations of the parts. Though it was estimated that each shelf would loaded with no more than 150 pounds when fully loaded

with files, it is important to test higher limits. For this reason we tested each box with loads exceeding this weight. To do this the weight of four different people, weighing 175, 190, 215 and 260 pounds respectively, was applied to horizontal plywood components. For everyone person the cart held its shape and proved to be able to support the previous expected weight of 150 pounds.

Mobility was tested last. The first method of testing mobility was to place the rolling base on a level, smooth concrete floor and push it in various directions for different angles to check for ease of rolling. Next, a single cubby box was placed on the base and rolling ease was again tested in a similar fashion. Addition and testing of the second and third boxes occurred similarly. The latches were then secured and the system was tested again. Included in the mobility testing was the testing of moving each of the boxes and testing which handle provided the most comfort and ease of movement. The movement of the cart as a whole was tried next to determine the best way to move the carts. Movement of the assembled cart was done by holding the side edges and pushing forward, holding the front edges and pushing sideways, pushing one side of the cart to rotate the angle of the cart, and pulling the cart from the front using the three different varieties of handles.

Once a method of transport was established, field testing of the empty cart commenced by means of moving the cart from the basement of Alden Hall to the robotics lab in Washburn Labs on the Worcester Polytechnic Institute campus. This tested the performance of the cart over a variety of terrains. The cart had to traverse smooth, concrete floor, pass into an elevator, cross smooth tiled floor, go through an exterior door with a slight lip, roll down a slightly graded handicapped, concrete ramp of light

roughness, and pass from a two inch high curb onto asphalt. From the asphalt, the cart had to roll down a rough concrete, sloped drop, and then go up onto cobblestone. After traversing the cobblestone the chosen path led the cart to a set of stairs. To overcome this obstacle it was first attempted to lift the cart when all of the shelves were detached so the cart was moved past the stairs incrementally by a group of four people. A similar method was used to move the cart into Washburn Labs where the cart was reassembled. It was then pushed across both smooth and carpeted floor to the robotics laboratory.

4.3 Results

When the order of the boxes was changed from the original set up, the alignment of the edges was off. In certain arrangements the boxes were rotated along the horizontal plane causing the corners to protrude as much as one inch past the corners of the adjacent box. This misalignment resulted in a corresponding misalignment of the latches. The latches did not line up in all possible arrangements of the three boxes. Careful examination of the boxes showed that the problem was caused by inaccurately placed cylinders on the tops of the boxes. The cylinders were removed and the boxes were stacked on top of each other. The cylinders were then set into the holes on the bottom of the boxes and screwed into place on the board below. The interchangeability was then retested and the alignment of the boxes was satisfactory. There was no more than 1/8" protruding in any formation of boxes.

There was little difficulty in readjusting the arrangement of the cart shelves using any of the methods with one, two, three or four people. The slowest method of rearranging the cart was having a single person do all the movements. The fastest method of interchanging two boxes was the simultaneous, stationary switching method with two

people. The fastest method of rearranging all three boxes was with three people, having one lift off the top box while the other two performed the simultaneous, stationary switching method. The four person methods were easy to perform with respect to weight but slightly more difficult than the other variations due to the crowding resulting from the close proximity of the four people. During this test, it was determined that the pullout, padded handles provided the easiest method of lifting the boxes.

The security covers slid into place as expected with enough resistance to prevent the covers from sliding out accidentally. There was some difficulty in sliding a cover into one of the slots but this was due to a buildup of sawdust along the track. The sawdust was brushed away and the cover slid normally into the space.

Each box fully supported 175, 190, 215 and 260 pound loads. There was slight bowing under the 260 pound load but there was little to no visible movement of the plywood under the lower three applied loads. Further stress analysis of the wood was done using SolidWorks programs.

The base rolled smoothly in all directions on the level, smooth concrete floor. There was no difficulty in pivoting, and the locking casters kept the wheels from spinning and pivoting as expected. The base performed with similar ease under the load of one, two and three empty boxes. When pushing the cart from the side, it was most comfortable to push by grasping the side-front edge with one hand and the side-back edge with the other hand. Pushing the cart from the front or back was easiest by gripping the sides of the cart. Pulling the cart was easiest using the pullout, padded handles. The best method of rotating the cart was to use one hand to hold one side as a pivot point and use the other

hand to push or pull the opposite side. The cart could be rotated from one side while pushing, but required more effort than the previous method.

The cart moved easily across the smooth, concrete floor of Alden and passed without difficulty into the elevator. The cart rolled satisfactorily over the smooth tiled floor of Alden Hall and had no difficulty going over the slight lip at the external door adjacent to the handicapped ramp. The wheels did not mark the floor and passage over the smooth surfaces resulted in very little noise. There was noticeable noise passing into and out of the elevator and crossing the raised bump at the door. The cart went easily down the low grade of the handicapped ramp and made only slightly more noise than it had on the smooth concrete floor. When going over the curb onto the asphalt, one of the latches came loose and fell off the cart. Other latches were also loosened from the short drop but remained attached to the cart and functional. Passage over the rough asphalt was easy but produced significantly more noise than over the previous surfaces. Crossing the rough, concrete slope was more difficult. The cart was pushed at an angle of about 45 degrees from a path that would go directly down the slope. There was noticeable noise when the cart was pushed over the cobblestone that was lower in frequency than during passage over the rough asphalt. The bumpy trip over the cobblestone resulted in the loss of another latch which had been previously been jarred loose from the curb. The other latches remained attached and functional. To pass the stairs between Stratton Hall and the CDC building, the cart was unlatched and three people carried one box each while a fourth person carried the wheel base up the steps. There was no difficulty disassembling, exchanging the shelves, or reassembling the cart. The cart functioned adequately while moving from the top of the stairs to the back door of the robotics lab, despite missing a

latch on one side of the wheel base. Disassembly, transportation of, and reassembly of the cart went without issue when moving the cart into the robotics lab. The cart rolled easily on both the smooth and carpeted floors in Washburn Labs. The cart was nearly silent during passage over carpeted floor.

4.4 Analysis

The boxes did not align properly in different stacked variations because of the placement of the side-movement stabilizing cylinders. Though the spots for these cylinders were carefully measured out, it is difficult to center the cylinder on mark where it is to be screwed in because the piece blocks the mark. The aforementioned problem caused slight variations in the location of the cylinders which resulted in poor interchangeability. To eliminate human error, the boxes were stacked on top of one another and the cylinders were dropped into their corresponding holes. The holes kept the cylinders within acceptable tolerances during fastening. If more of these carts are to be produced, the latter method should be used in place of the former method. Also, alignment of the boxes should be tested before attaching the luaun board to the interior of the cart as this restricts access to the holes on the bottom of the cart. This was not considered during the construction of the prototype and required fifteen to twenty minutes of time to rectify the problem.

It was determined that the slowest method of rearranging two shelves was to have a single person do all the movements. This is to be expected because picking up a cubby requires two hands due to its unwieldy dimensions. Though this method is not the fastest, single-user functionality is an essential element of the cart design because it may be the

only option available in many situations. Using this method, a driver would not need assistance to load an empty cart onto a truck in the absence of a loading dock.

The quicker method of interchanging two boxes is the simultaneous, stationary switching method described in the testing section. The method is time saving in its efficiency but bears very few practical uses. This method was tested using empty cubbies. There is no foreseeable reason to switch two empty cubbies because they are identical and their position relative to each other should be irrelevant. In the event that the top box on a cart is empty and the one below it is lightly loaded, it should be possible to interchange the two boxes to allow for access to the files without crouching which can strain the back muscles. The same principle applies for using three or four people to interchange the sections. The only advantage to having three or four people involved is the possibility of moving heavier, file loaded boxes from the bottom of the cart to the top of the cart to provide ease of removal. It should be noted that fully loaded boxes are expected to weigh approximately 150 pounds; therefore lifting a loaded box has a greater risk of injury than simply stooping down to retrieve the files. Because there is no mechanism to prevent the user from attempting to perform such an operation, it should be explicitly stated to all people planning to use the cart that they should avoid removing loaded boxes from the cart.

During the testing of interchangeability, it was found that the pullout, padded handles were the best handle to be used for the boxes. The handles provided for a sturdy and comfortable grip when in use and did not protrude from the edge of the box when not in use. The other two types of handles both bore the advantage of being recessed into the side of the box but were not as good because they limited the user to a relatively small

gripping area compared to that of the pullout handles. The other obvious benefit to the pullout handles is that they cost about half as much as the other two options which reduces the cost of a four level cart by \$60-80.

The luaun security covers served their purpose well. Though they do not lock, they do provide the basic security of keeping the contents of the box hidden from passerby. This reusable cover provides the same function as the black cellophane that Iron Mountain currently uses to enclose their carts. This saves money by reducing wasted product expense. Another benefit of avoiding the use of the cellophane is the carts can be more easily loaded and unloaded from a truck. This is because the cellophane covered carts cause a large amount of friction between each other making it difficult to closely pack them into a truck. Wood on wood contact has significantly reduced friction. The detriment to using the sliding security covers is that someone could slide them open and look at the files inside and leave no visible evidence of having done so. With the black cellophane, the wrap would have to be compromised to view the files and this would be evident and alert Iron Mountain to the possibility of a security breach.

Physical and theoretical stress analysis of the wood showed that it is easily capable of supporting the proposed load per box. [See Appendix B]

The cart rolled with ease due to the fact that the applied loads were well under the support limitations of the casters. The most comfortable method of pushing a cart from the side was to push by grasping the side-front edge with one hand and the side-back edge with the other hand. This result is to be expected because it is the most ergonomic way to hold the cart and does not require any unnatural movement of the arms. For the same reason, it was most comfortable to push an empty cart forwards or backwards by

grasping the side edges of either the front or back. This movement would not be advised when pushing a loaded cart as there is a significantly increased possibility of tipping when pushing in those directions. The best method of rotating a cart was to use one hand to hold one side as a pivot point and use the other hand to push or pull the opposite side. This is a result of the mechanical advantage of using the maximal lever arm available along the rigid body of the cart. The decreased mechanical advantage of pivoting the cart from the side by pulling with one arm and pushing with the other requires a great deal more work. This method risks injury of the user if attempted with a fully loaded cart.

Field testing of the cart brought up two important points. First, over rougher surfaces, the noise of the cart increased. Second, sudden impact and subsequent mechanical vibration cause unfastening of the 1/2" brass screws. After replacing the brass screws with sturdier screws, the latches remained firmly in place. Even though the new screws are better equipped to handle sudden impact, it is best to avoid this occurrence as this may dramatically decrease the product life of both the casters and the latches.

5.0 Conclusion

The goal of this project was to redesign Iron Mountains file transportation carts. The current carts are large, awkward to move, unreliable, and contain no security features. The design solution addressed these issues by making a modular cart with a sliding door for each shelf. The design allows the user to bring as small or as large a cart as is necessary for the job, up to three shelves. The design addressed all of the client's concerns in regards to user safety, ease of use, and file security.

The prototype of the cart was made using plywood; ideally the finished product will be made of plastic sheeting or injection molded. The current disadvantages to the design are the weight of the cart and the low height of the first shelf. The advantages are the modularity of the cart; all of the shelves can be interchanged. There are now built in security features; a sliding door that can be stored on the back side of each shelf. The new cart is also much stronger than the carts that Iron Mountain is currently using.

The next step to take is further field testing. One or two more prototypes should be put into use at Iron Mountain. If they hold up well after a short trial period, of a month or two, more carts can be for a longer trial period, perhaps six months to a year. If after this second, longer trial period the carts are working as expected mass production can be looked into. If the Northborough facility suggests that these carts should be put into circulation at other sites injection molding can be researched more thoroughly. Currently injection molding is not a cost effective solution due to the initial cost of the die. If the carts were to be put into use at several of the Iron Mountain locations the cost would be less of an issue.

References

Folding Truck with Solid Tilt Shelves. Retrieved October 5, 2007 from Global Industrial Web site:

<http://www.globalindustrial.com/gcs/product/productInfo.web?&infoParam.itemKey=30047524&infoParam.pic GroupKey=486>

Nest Away Folding Truck 1200 Lb Capacity. Retrieved October 5, 2007 from Global Industrial Web site:

<http://www.globalindustrial.com/gcs/product/productInfo.web?&infoParam.itemKey=30013779&infoParam.pic GroupKey=1921>

Shelving Direct. Retrieved October 4, 2007, from Shelving Direct Web site:

<http://www.shelving-direct.com/asp/producto.asp?id1=960&id2=187#>

United States Patent Full-Text Database. Retrieved September 26, 2007 from the United States Patent Office Web site:

<http://patft.uspto.gov/netahtml/PTO/srchnum.htm>
(Type patent number in search bar)

Appendix A

Material Stress Analysis

Weight is for 16" by 36"

150 pounds used for Stress (psi)

Material	Thickness (in.)	Weight (lb)	Stress (psi)	Displacement (in)	FOS
AISI 304 Steel	0.125	20.8093	6835.13545	0.145222	Good
Aluminum 1060 Alloy	0.125	7.02315	6767.78	0.3990512	Fail
Balsa Wood	0.125	0.41616	6800.38441	9.19693	Fail
Glass	0.125	6.39262	6947.5397	0.3991063	?
PVC	0.125	3.38152	6534.41421	11.318858	?
Titanium	0.125	11.9654	6820.55916	0.2507902	Good
AISI 304 Steel	0.25	41.6186	1672.2126	0.018219	Good
Aluminum 1060 Alloy	0.25	14.0463	1643.53864	0.050062	Good
Balsa Wood	0.25	0.83232	1661.10271	1.154059	Good
Glass	0.25	12.7852	1717.73994	0.05007008	?
PVC	0.25	6.76303	1629.891	1.42069	?
Titanium	0.25	23.9307	1665.77292	0.03146311	Good
AISI 304 Steel	0.375	62.428	747.771	0.0054133	Good
Aluminum 1060 Alloy	0.375	21.0694	732.7161	0.014875	Good
Balsa Wood	0.375	1.24848	752.814	0.3428035	Good
Glass	0.375	19.1779	777.46174	0.01487748	?
PVC	0.375	10.1445	706.6166	0.42196063	?
Titanium	0.375	35.8961	744.3888	0.00934854	Good
AISI 304 Steel	0.5	83.2373	409.64	0.0022919	Good
Aluminum 1060 Alloy	0.5	28.0926	400.7726	0.0062989	Good
Balsa Wood	0.5	1.66464	408.6018	0.145155	Good
Glass	0.5	25.5705	426.489269	0.00629783	?
PVC	0.5	13.5261	391.4061	0.1787827	?
Titanium	0.5	47.8614	406.08246	0.00395819	Good

Appendix B

Static Displacement Photographs

Glass .125 inch thick sheet displacement

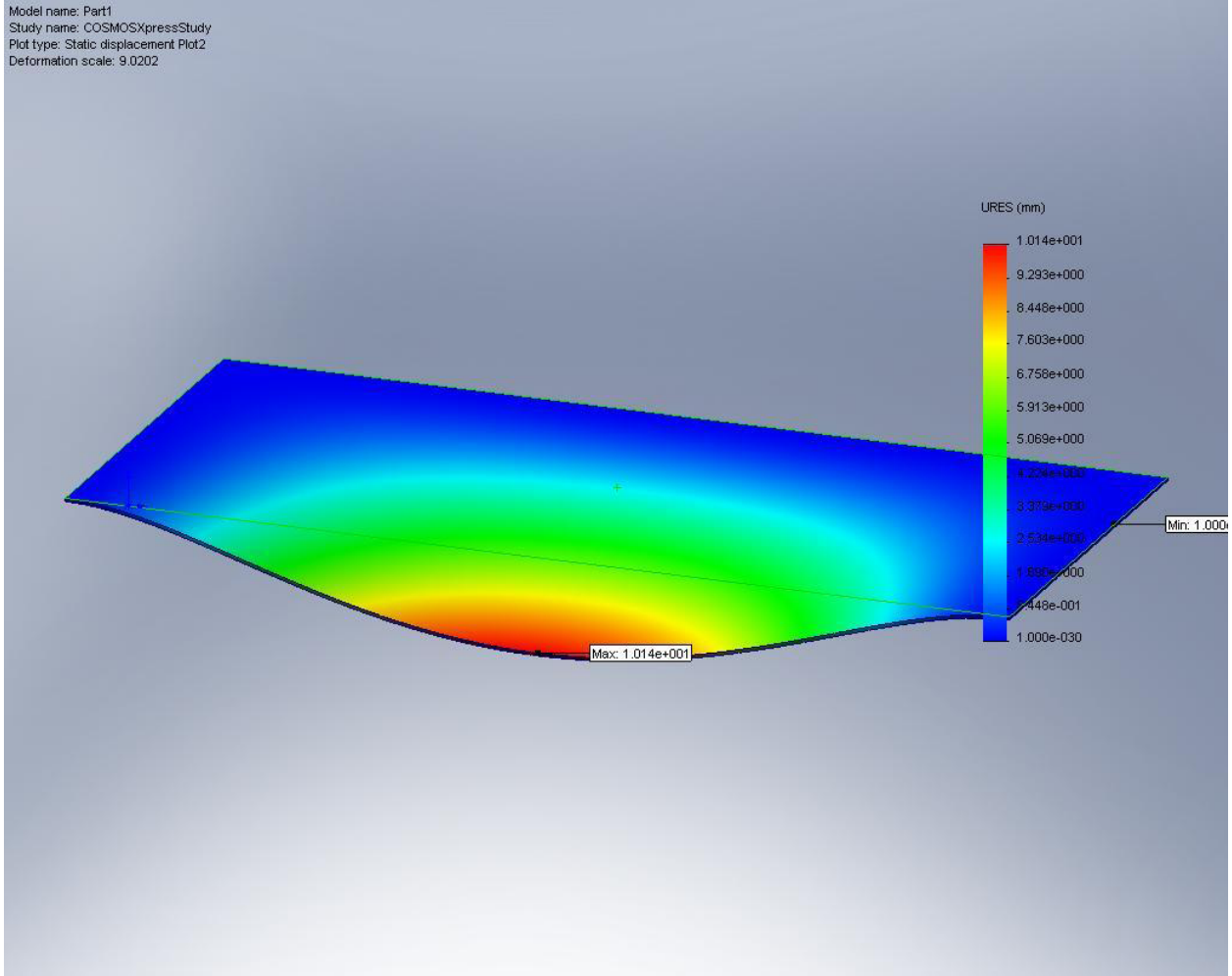

Glass .25 inch sheet displacement

Model name: Part1
Study name: COSMOSXpressStudy
Plot type: Static displacement Plot2
Deformation scale: 71.9008

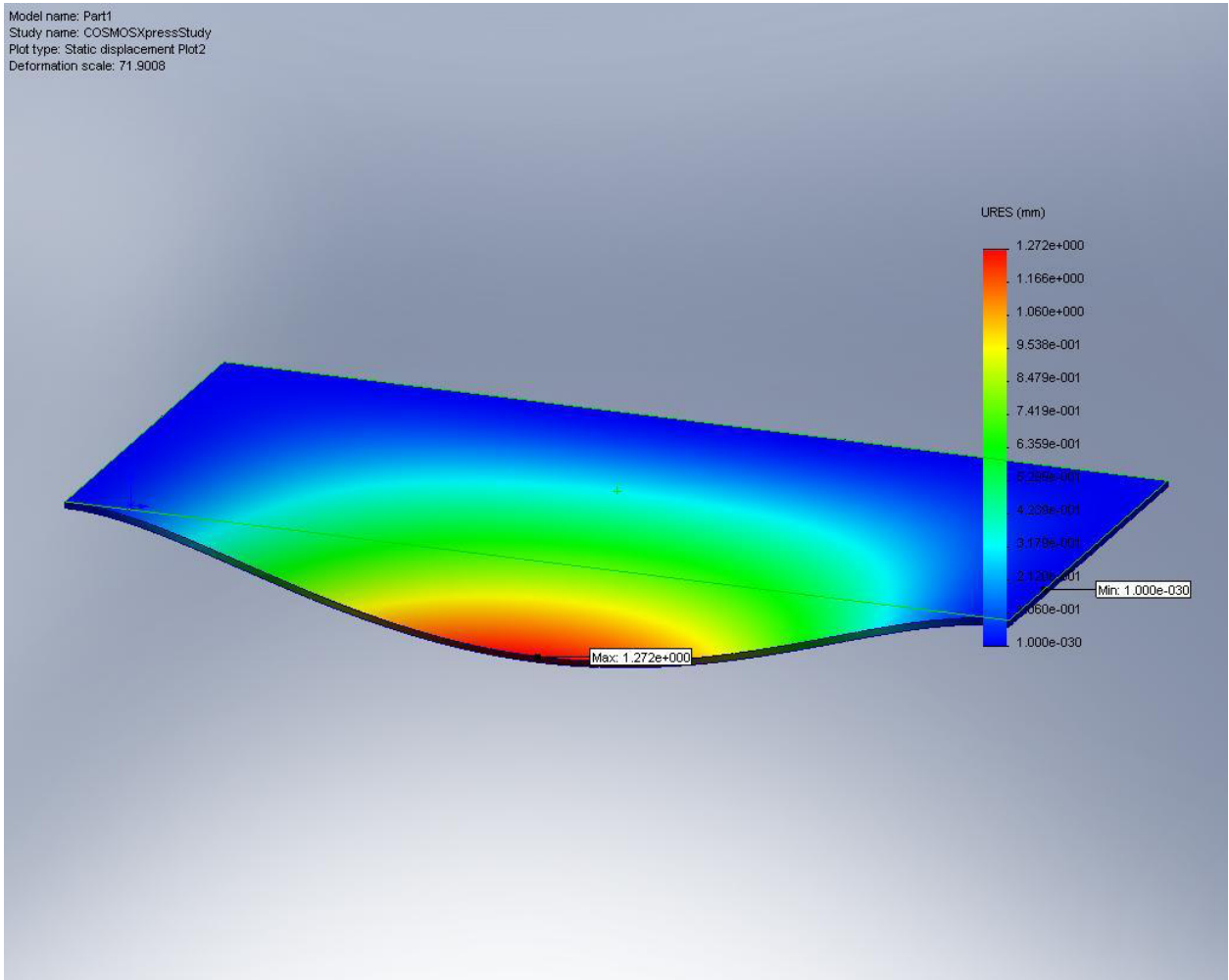

Glass .375 inch sheet displacement

Model name: Part1
Study name: COSMOSXpressStudy
Plot type: Static displacement Plot2
Deformation scale: 241.99

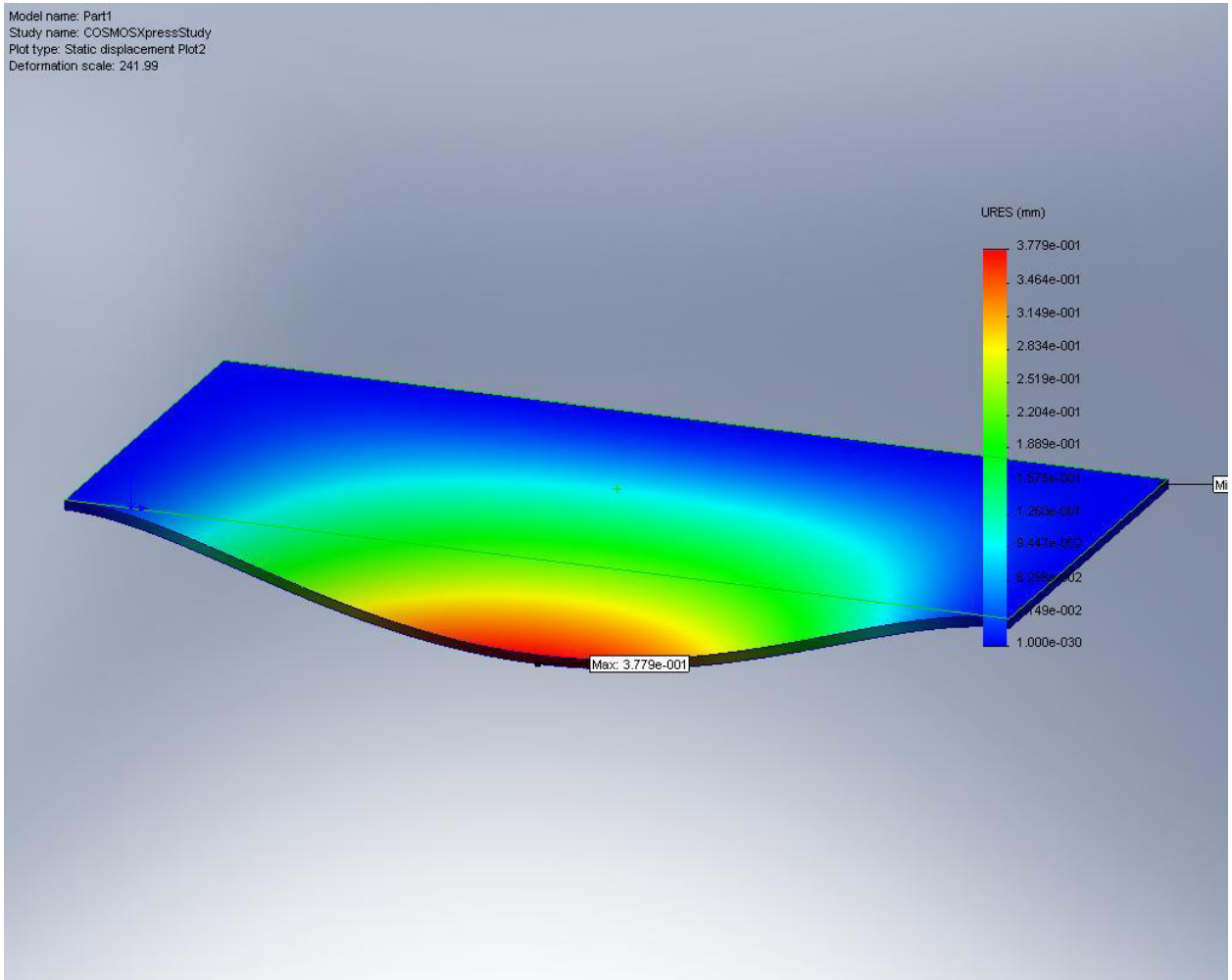

Glass .5 inch sheet displacement

Model name: Part1
Study name: COSMOSXpressStudy
Plot type: Static displacement Plot2
Deformation scale: 571.681

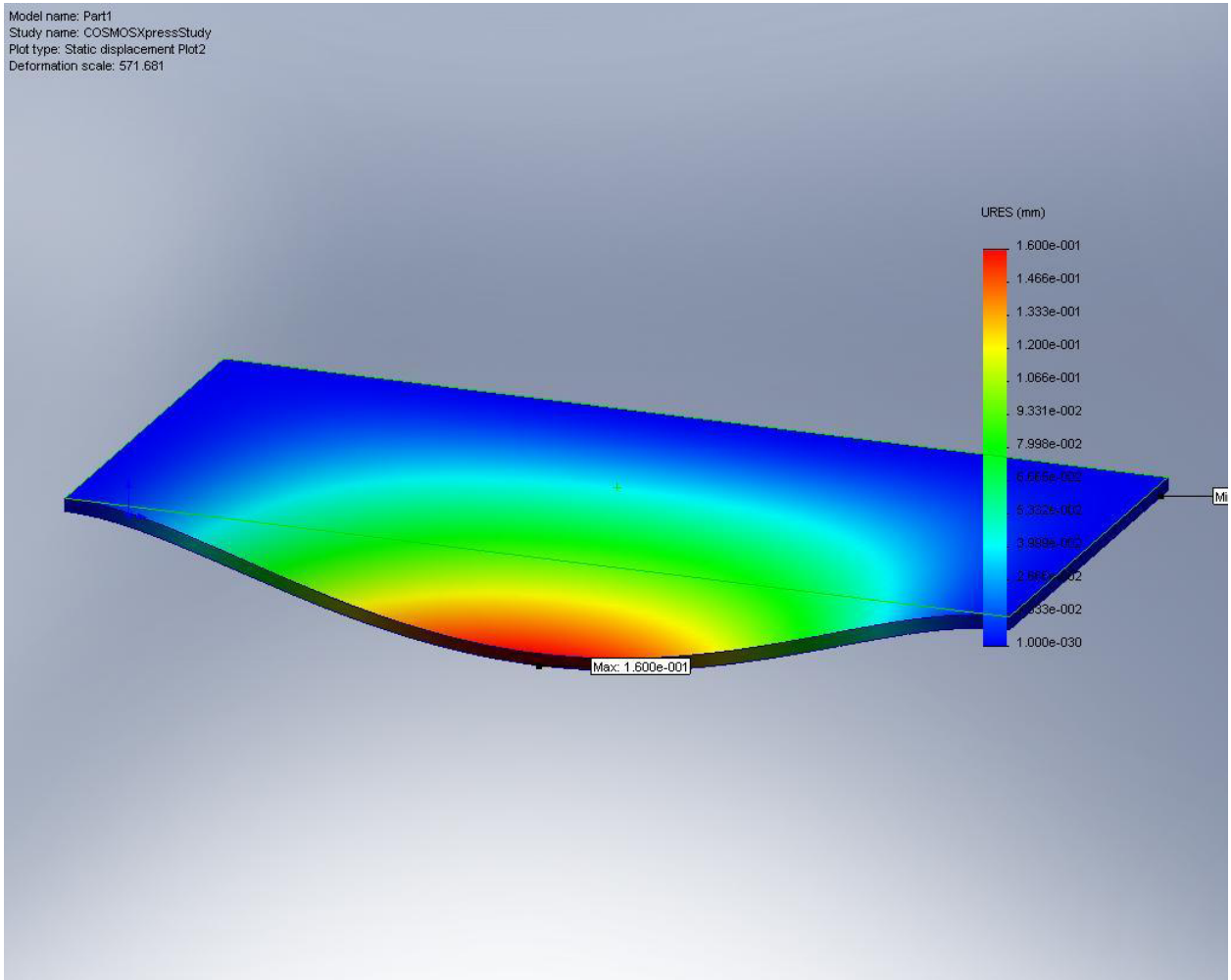

PVC .125 inch sheet displacement

Model name: Part1
Study name: COSMOSXpressStudy
Plot type: Static displacement Plot2
Deformation scale: 0.318055

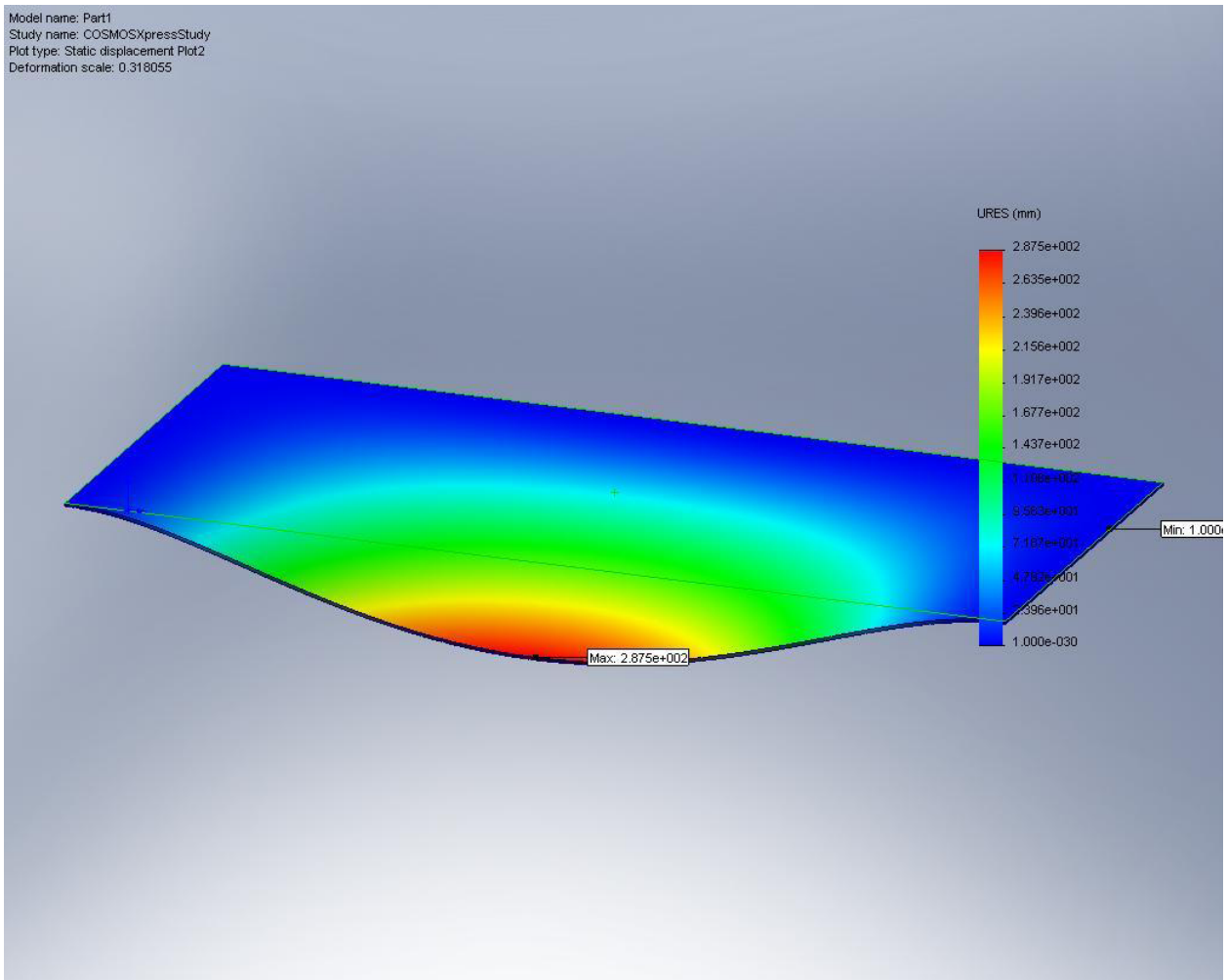

PVC .25 inch sheet displacement

Model name: Part1
Study name: COSMOSXpressStudy
Plot type: Static displacement Plot2
Deformation scale: 2.53403

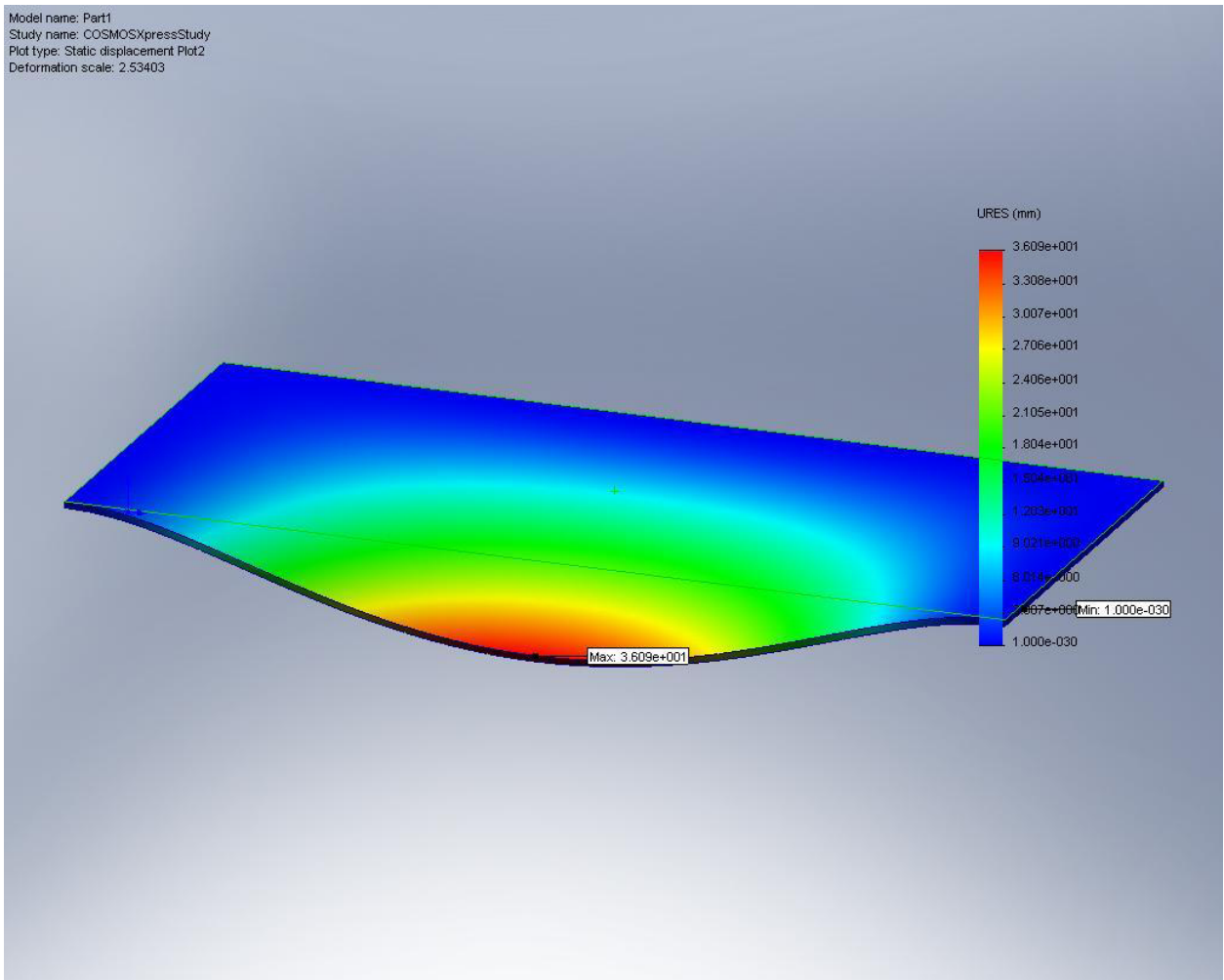

PVC .375 inch sheet displacement

Model name: Part1
Study name: COSMOSXpressStudy
Plot type: Static displacement Plot2
Deformation scale: 8.53199

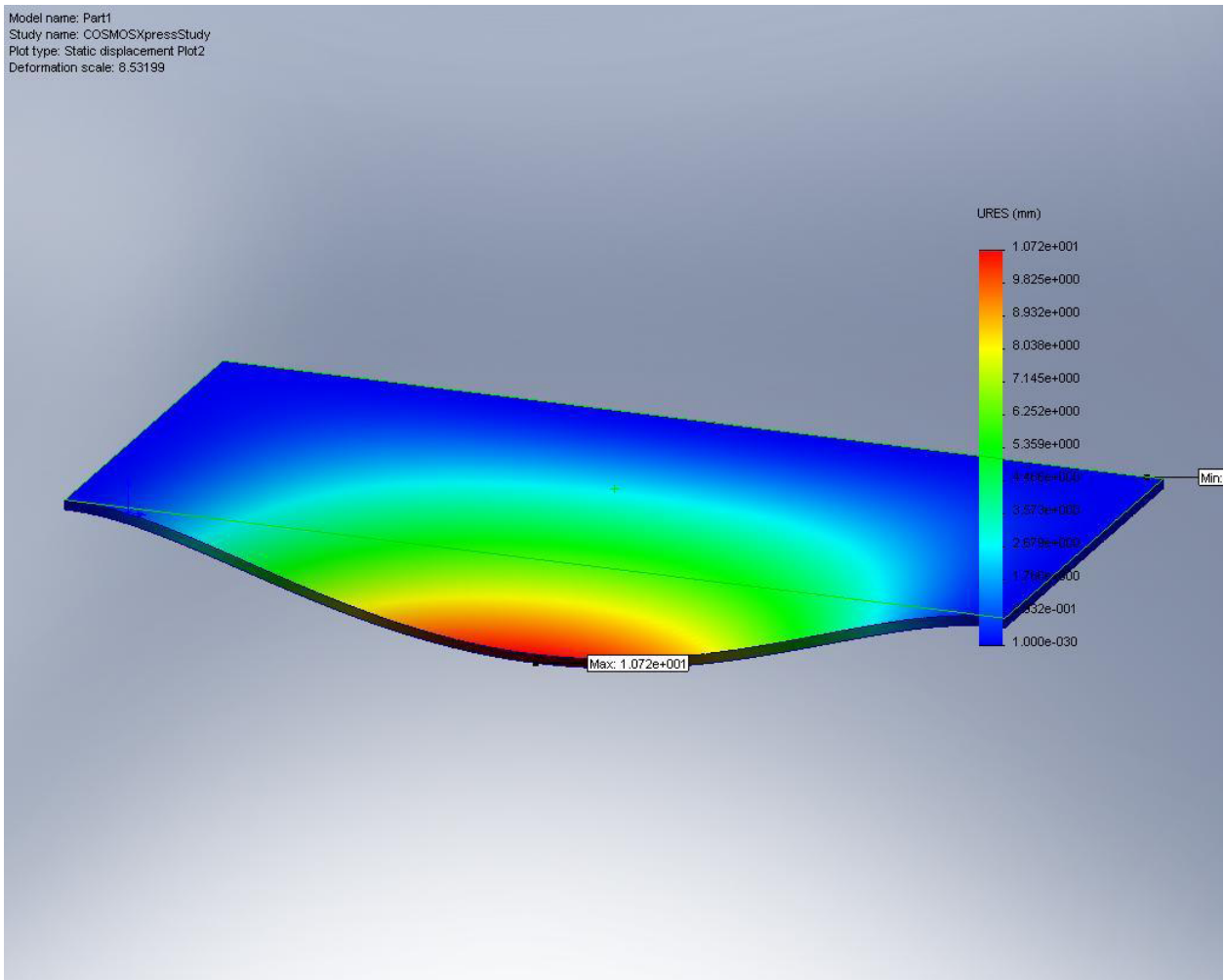

PVC .5 inch sheet displacement

Model name: Part1
Study name: COSMOSXpressStudy
Plot type: Static displacement Plot2
Deformation scale: 20.1379

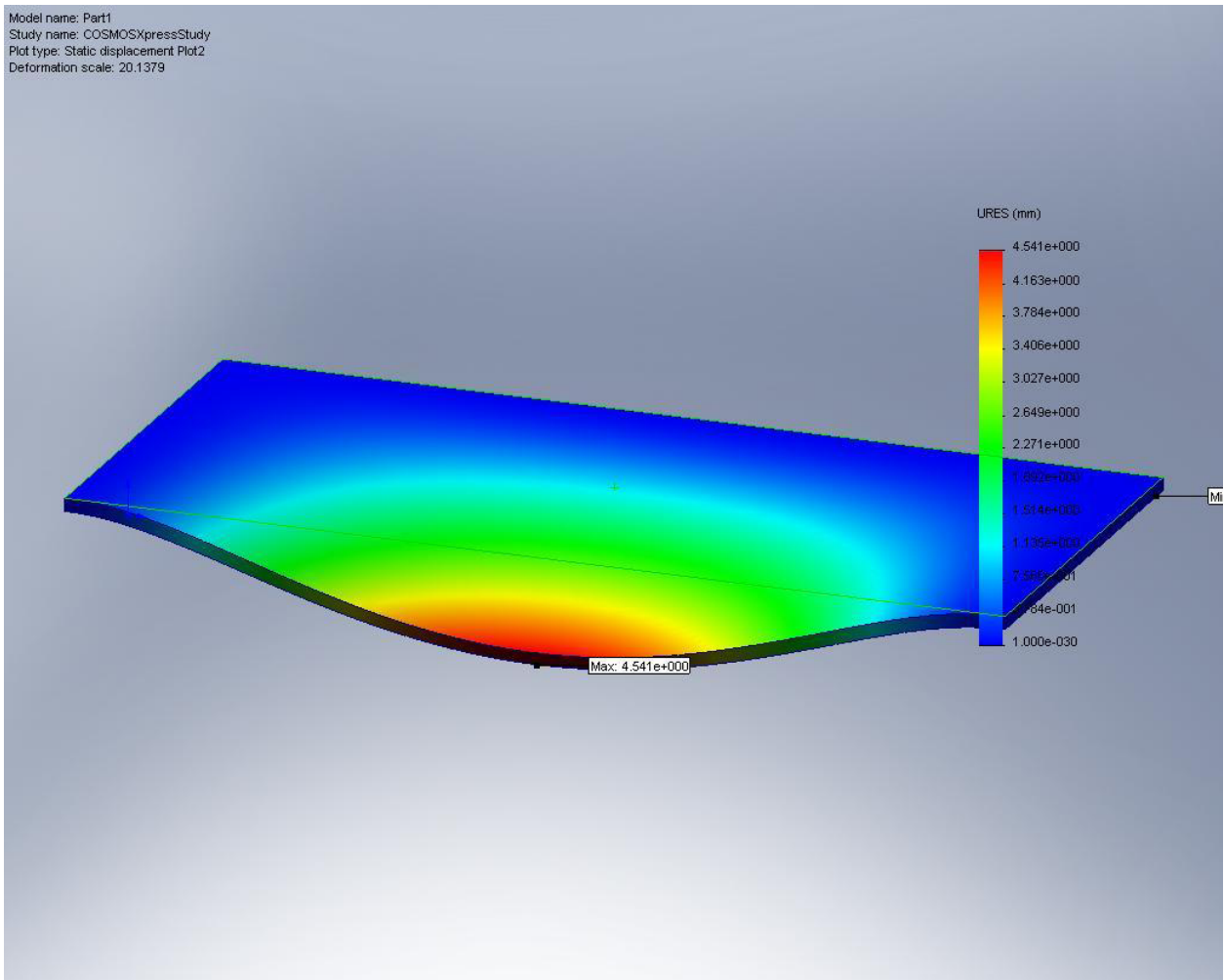

Titanium .125 inch sheet displacement

Model name: Part1
Study name: COSMOSXpressStudy
Plot type: Static displacement Plot2
Deformation scale: 14.3547

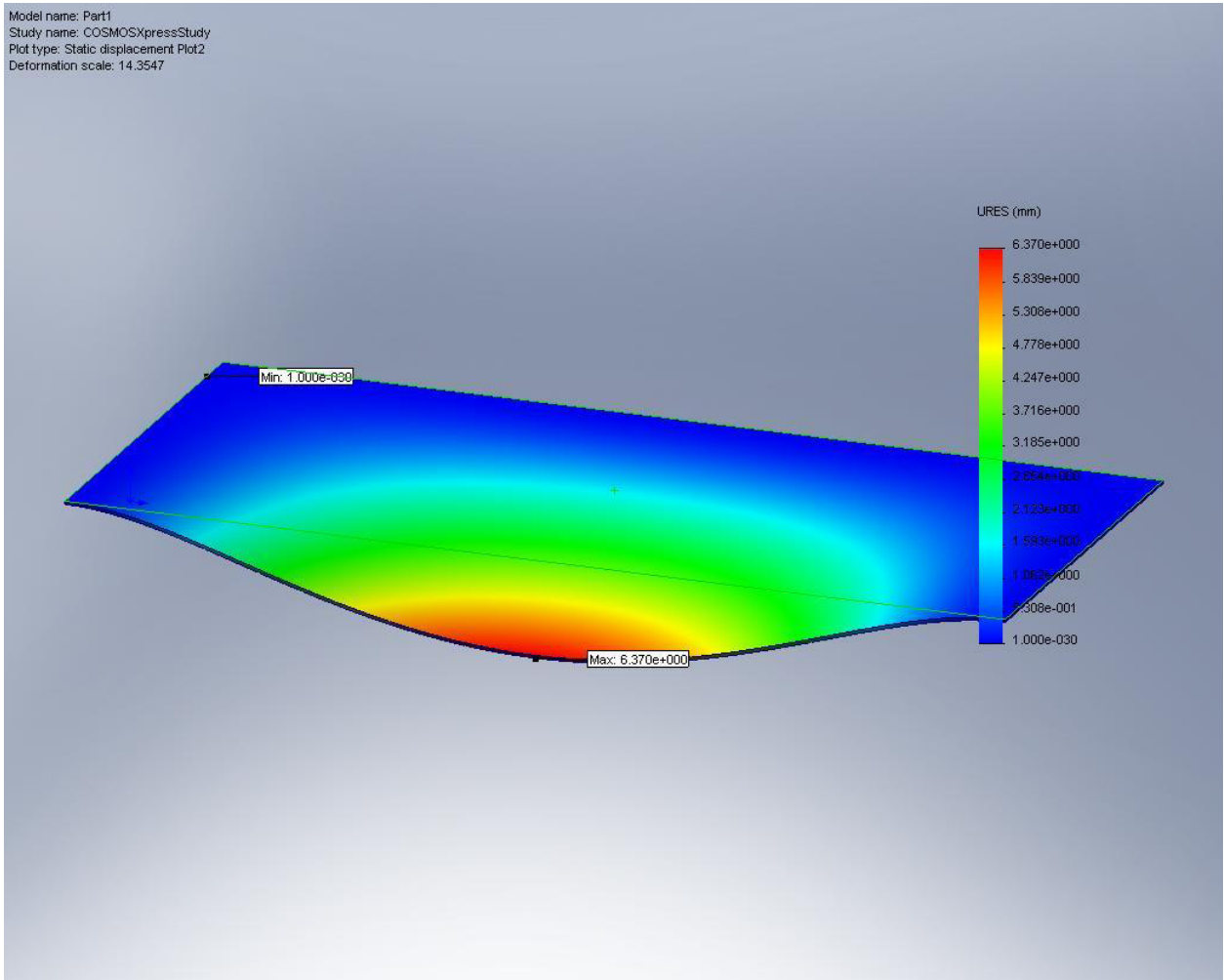

Titanium .25 inch sheet displacement

Model name: Part1
Study name: COSMOSXpressStudy
Plot type: Static displacement Plot2
Deformation scale: 114.422

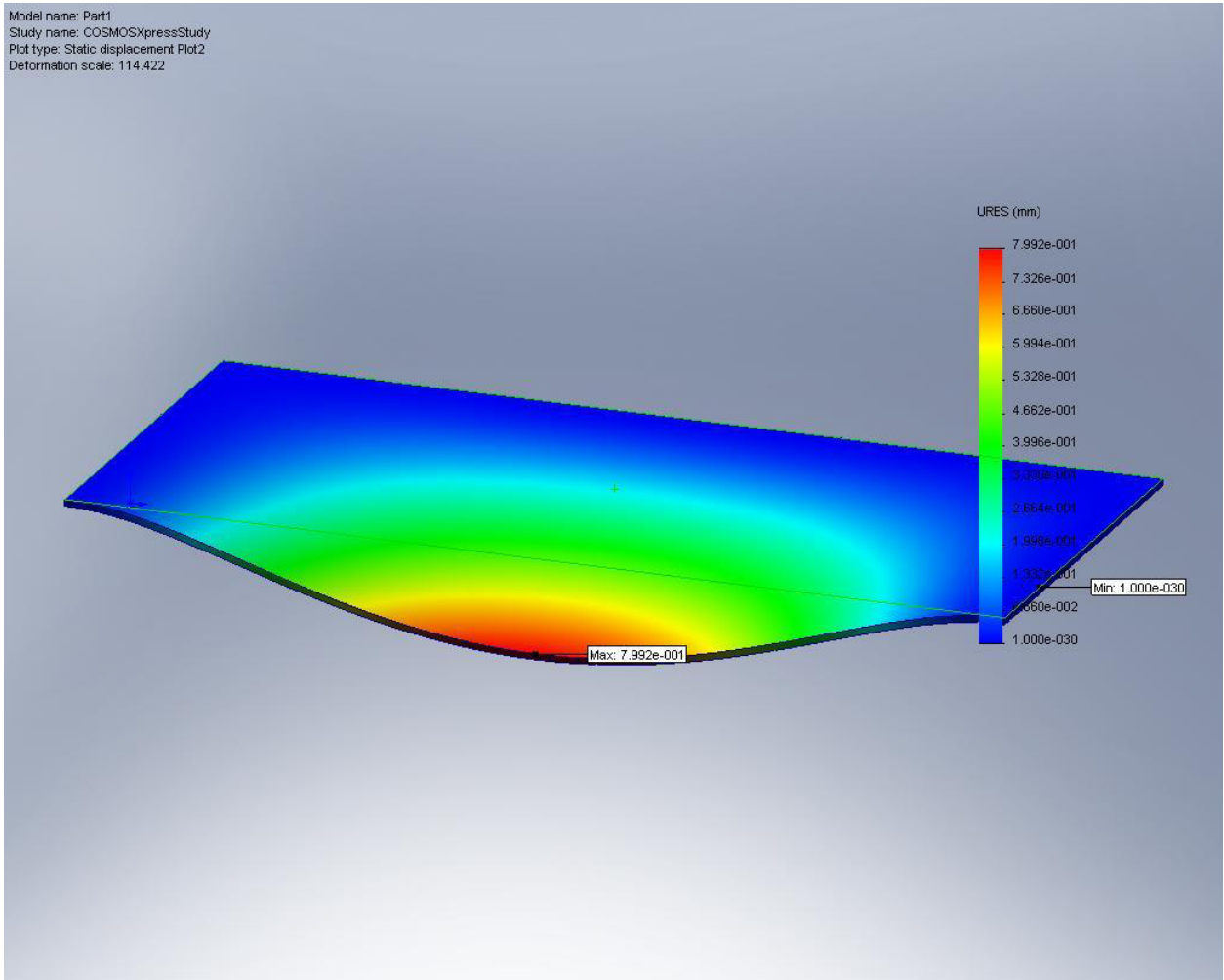

Titanium .375 inch sheet displacement

Model name: Part1
Study name: COSMOSXpressStudy
Plot type: Static displacement Plot2
Deformation scale: 385.106

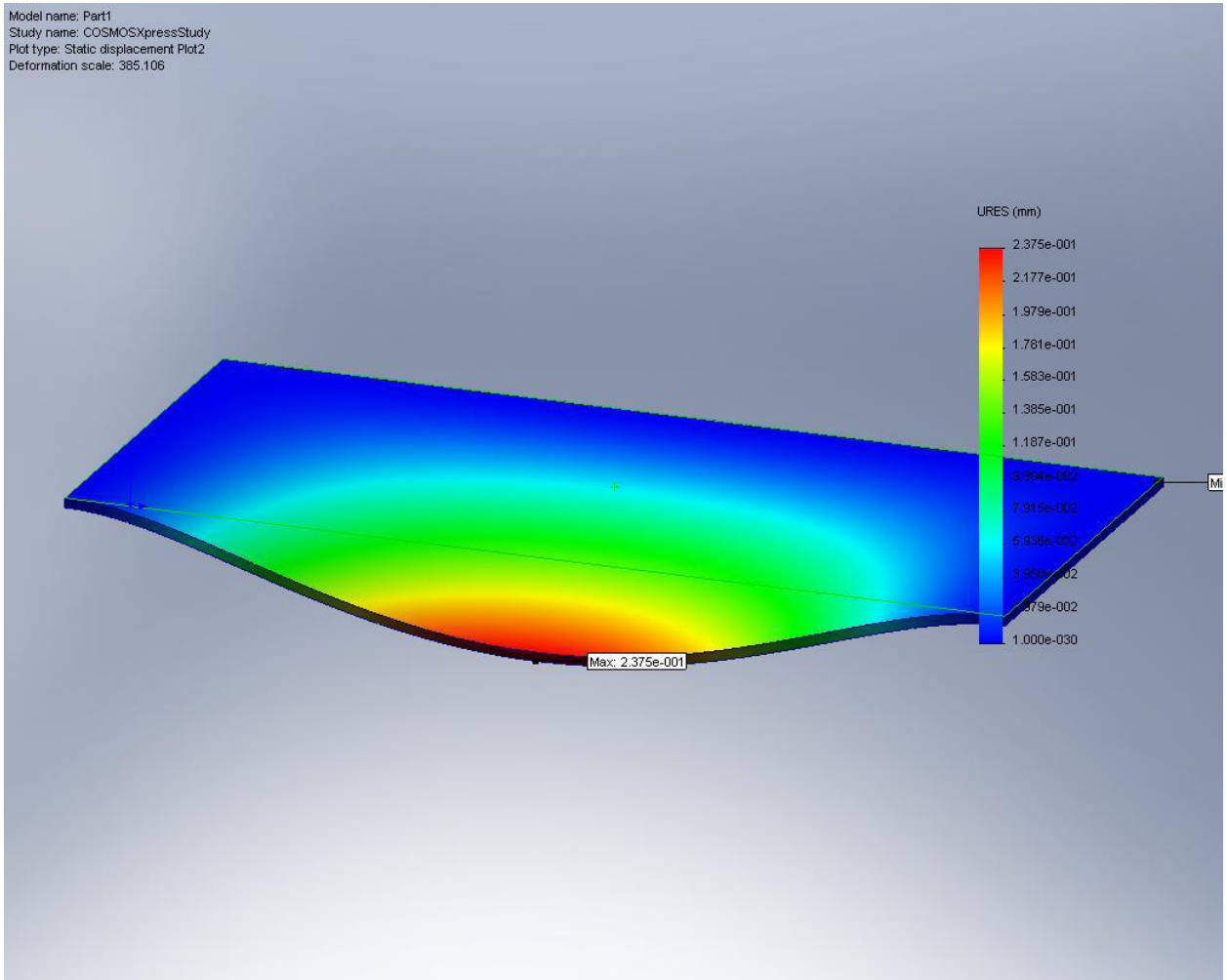

Titanium .5 inch sheet displacement

Model name: Part1
Study name: COSMOSXpressStudy
Plot type: Static displacement Plot2
Deformation scale: 909.594

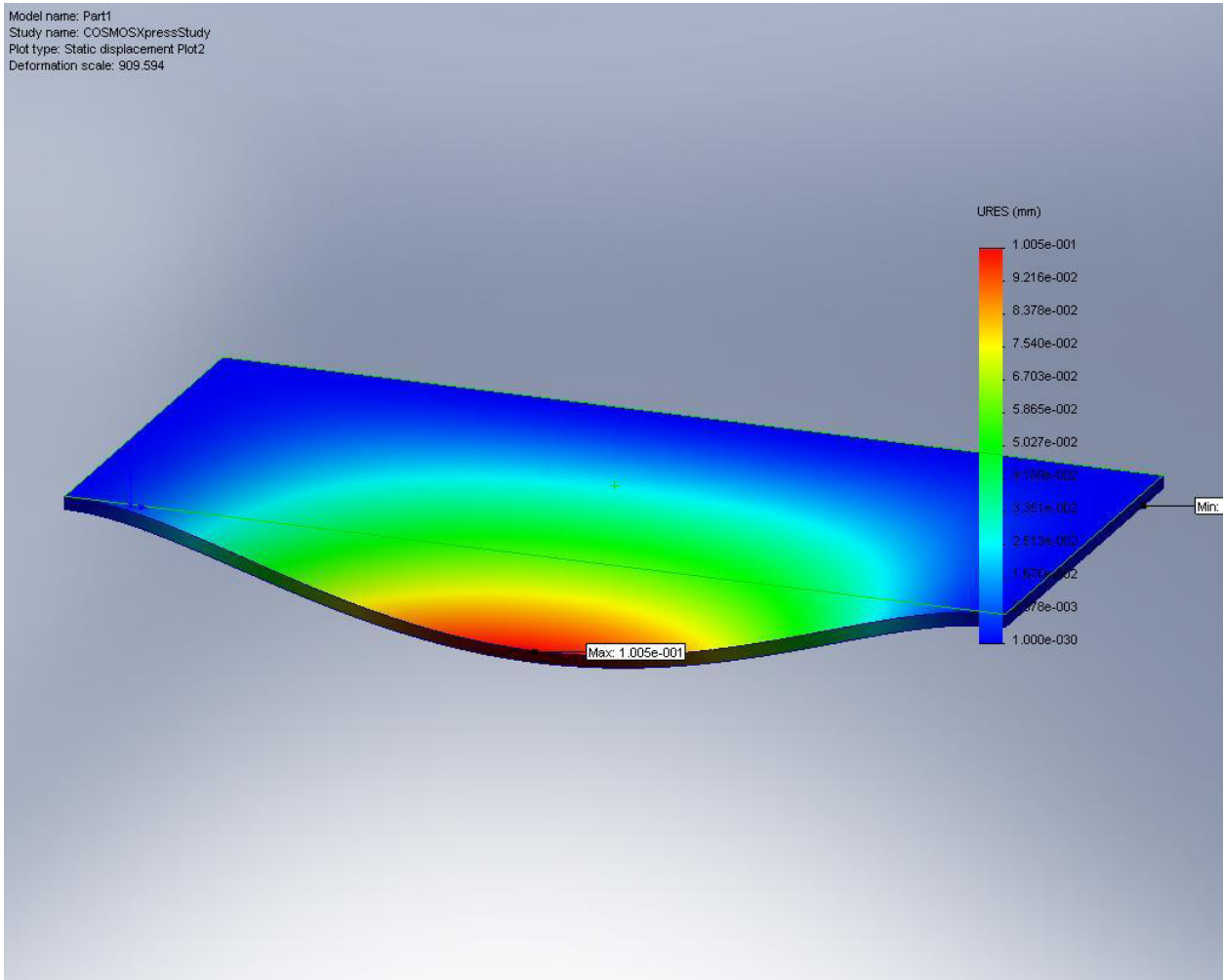

AISI 304 Steel .125 inch sheet displacement

Model name: Part1
Study name: COSMOSXpressStudy
Plot type: Static displacement Plot2
Deformation scale: 24.7898

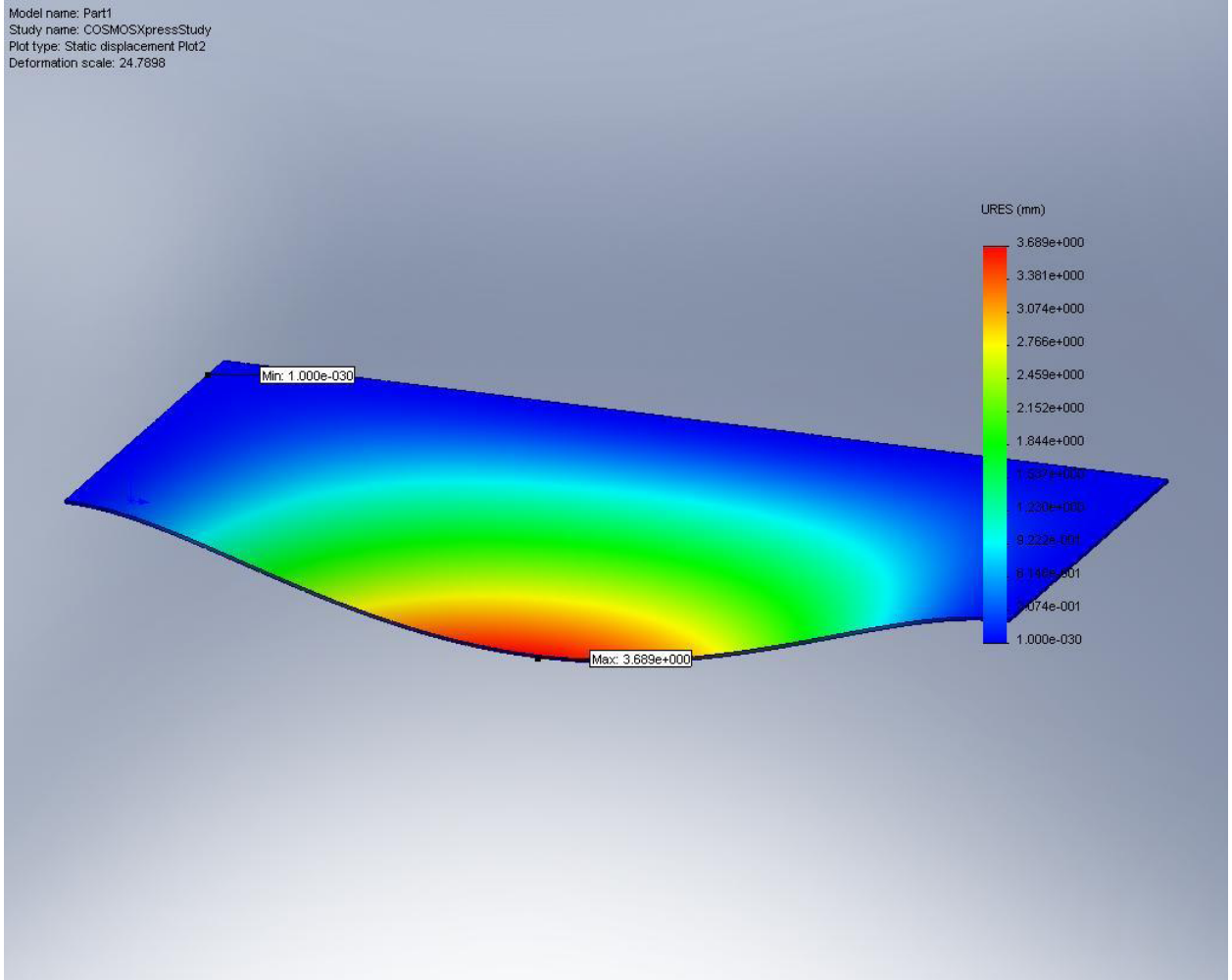

AISI 304 Steel .25 inch sheet displacement

Model name: Part1
Study name: COSMOSXpressStudy
Plot type: Static displacement Plot2
Deformation scale: 197.6

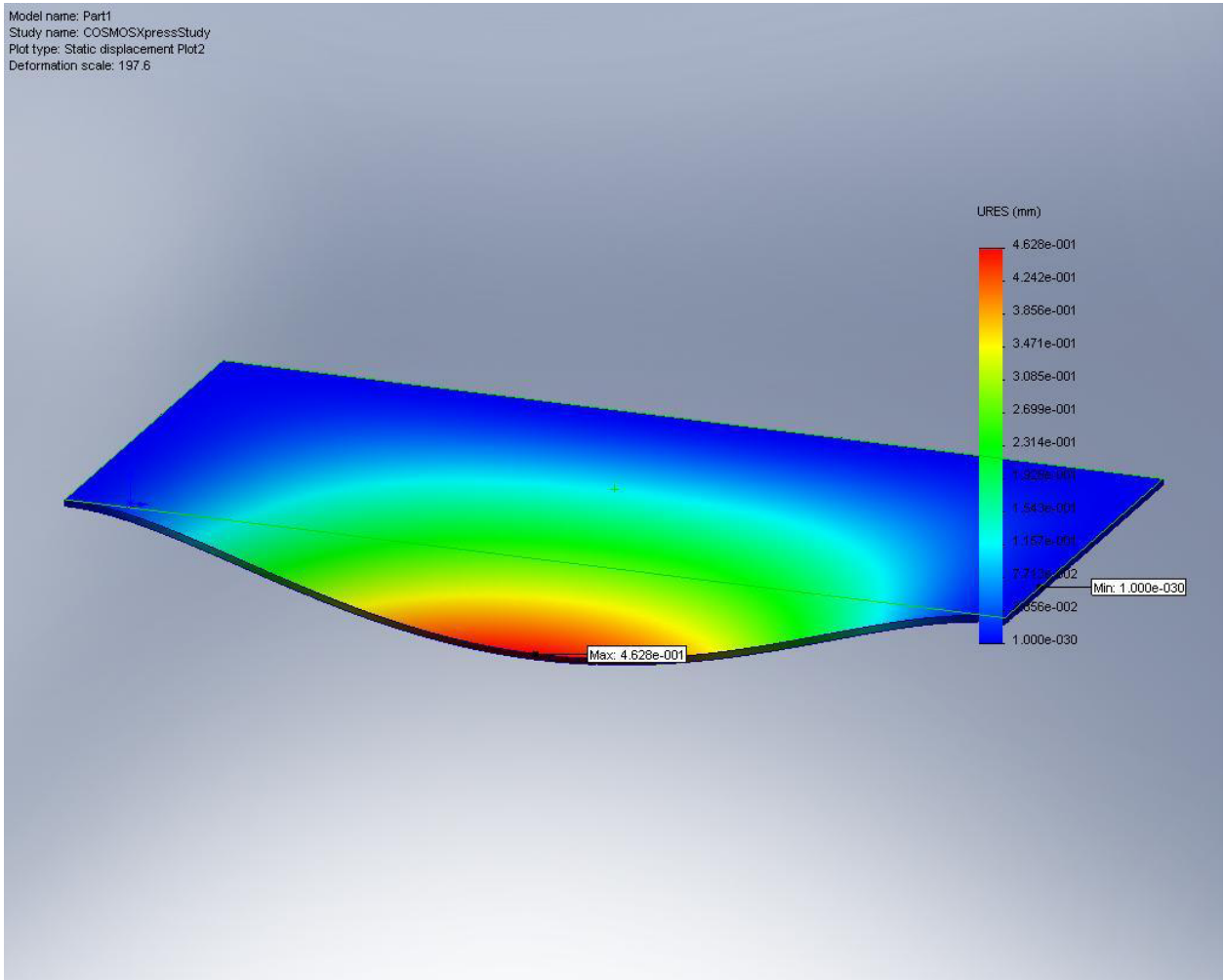

AISI 304 Steel .375 inch sheet displacement

Model name: Part1
Study name: COSMOSXpressStudy
Plot type: Static displacement Plot2
Deformation scale: 571.565

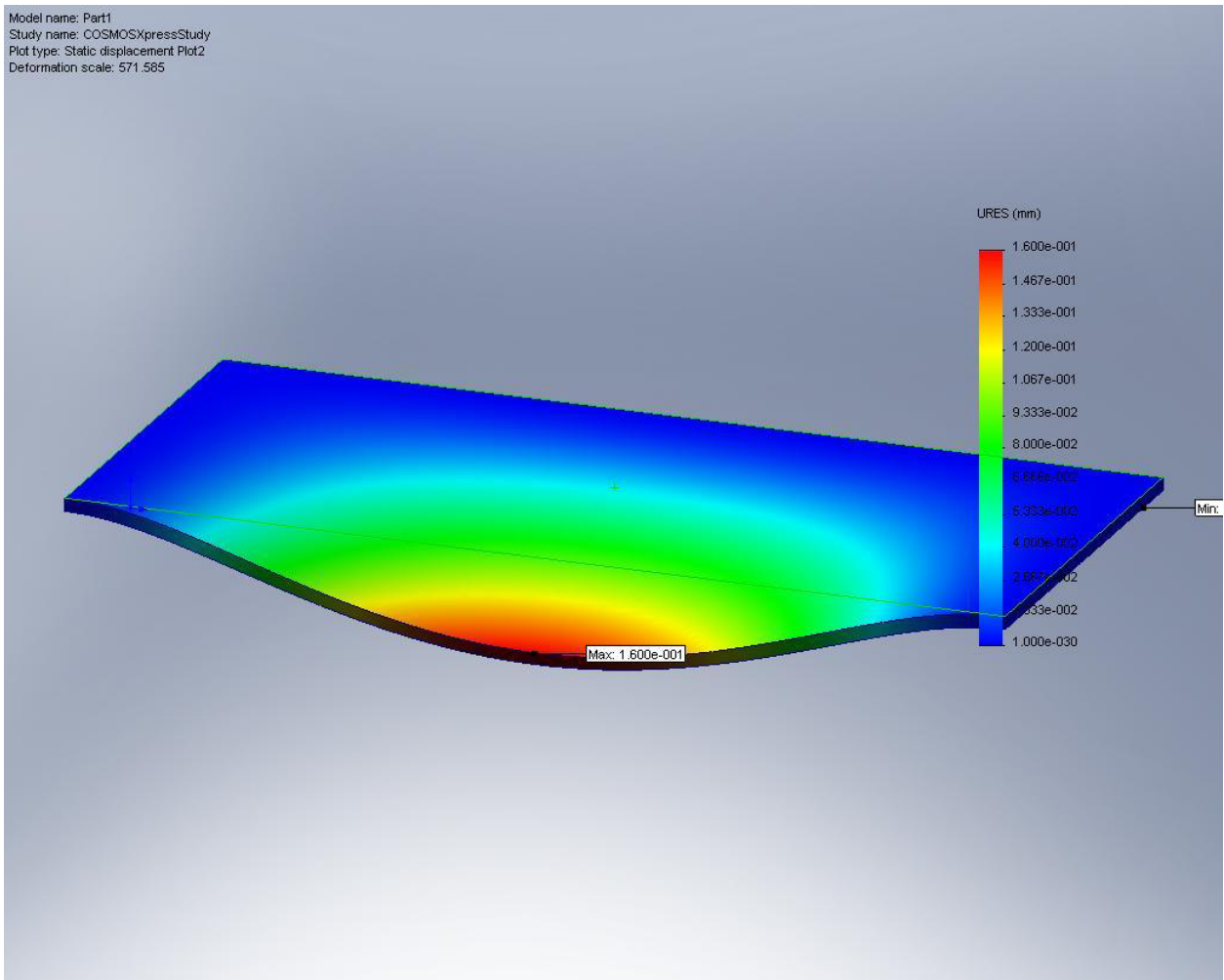

AISI 304 Steel .5 inch sheet displacement

Model name: Part1
Study name: COSMOSXpressStudy
Plot type: Static displacement Plot2
Deformation scale: 1570.86

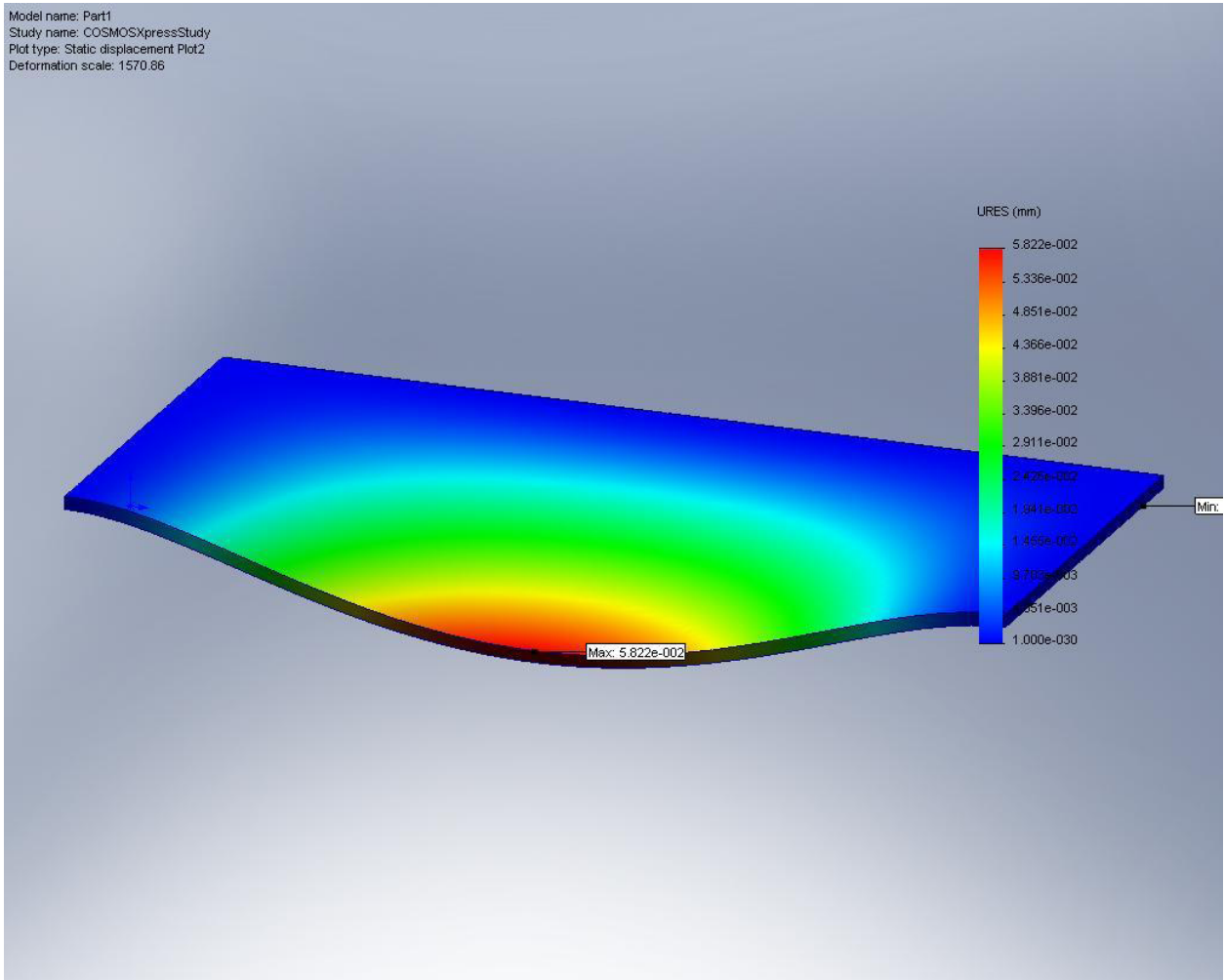

Aluminum 1060 Alloy .125 inch sheet displacement

Model name: Part1
Study name: COSMOSXpressStudy
Plot type: Static displacement Plot2
Deformation scale: 9.02144

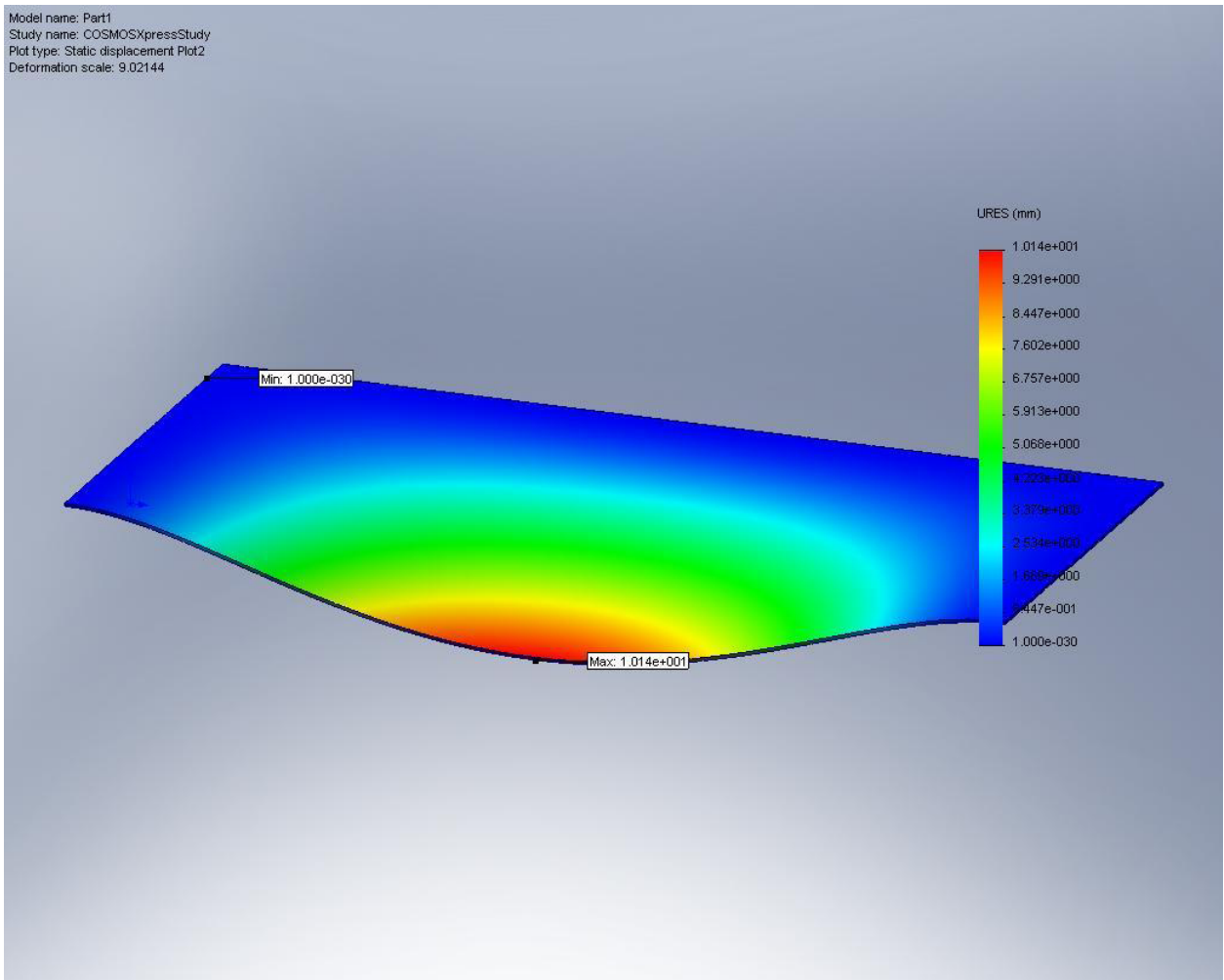

Aluminum 1060 Alloy .25 inch sheet displacement

Model name: Part1
Study name: COSMOSXpressStudy
Plot type: Static displacement Plot2
Deformation scale: 71.9124

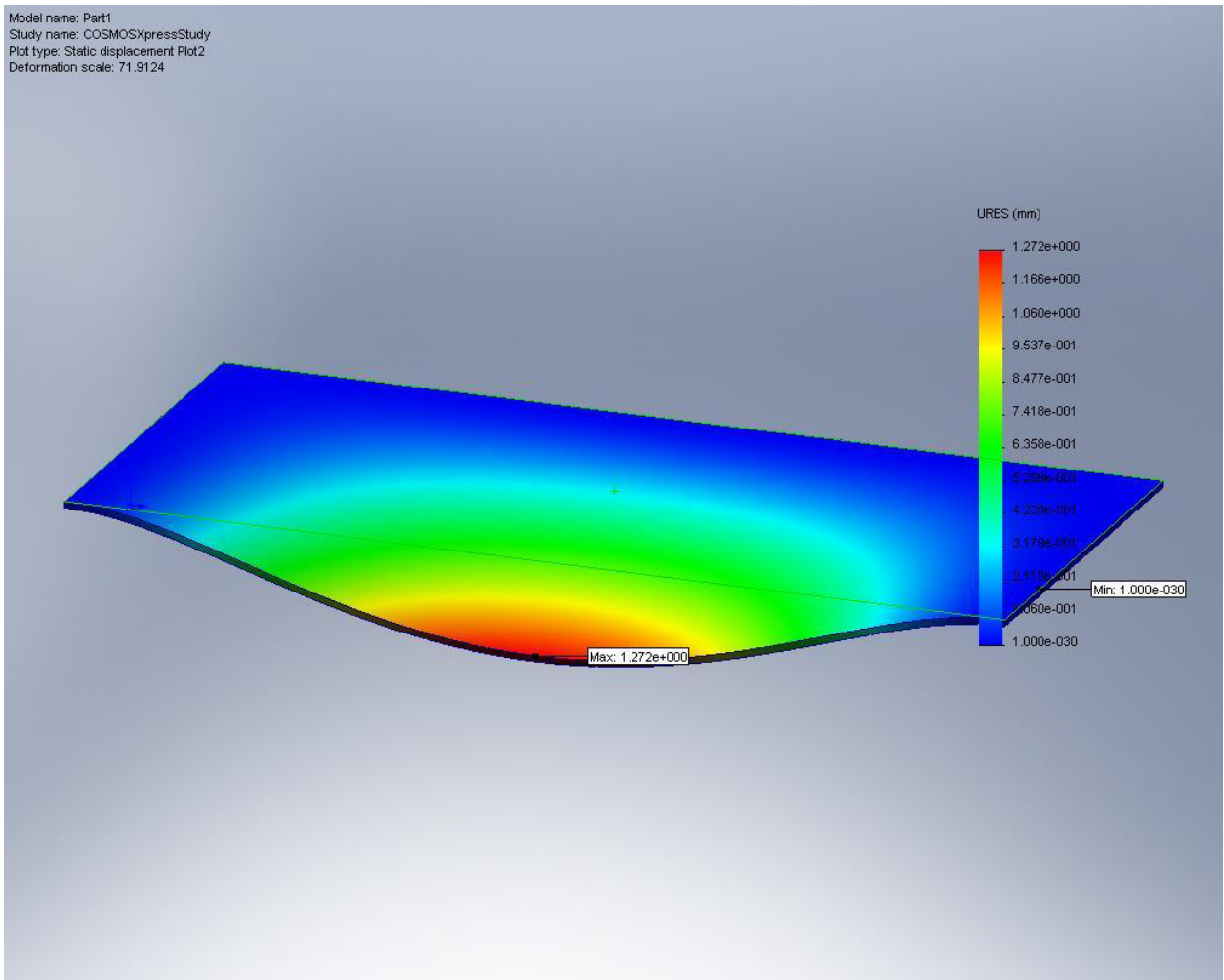

Aluminum 1060 Alloy .375 inch sheet displacement

Model name: Part1
Study name: COSMOSXpressStudy
Plot type: Static displacement Plot2
Deformation scale: 242.029

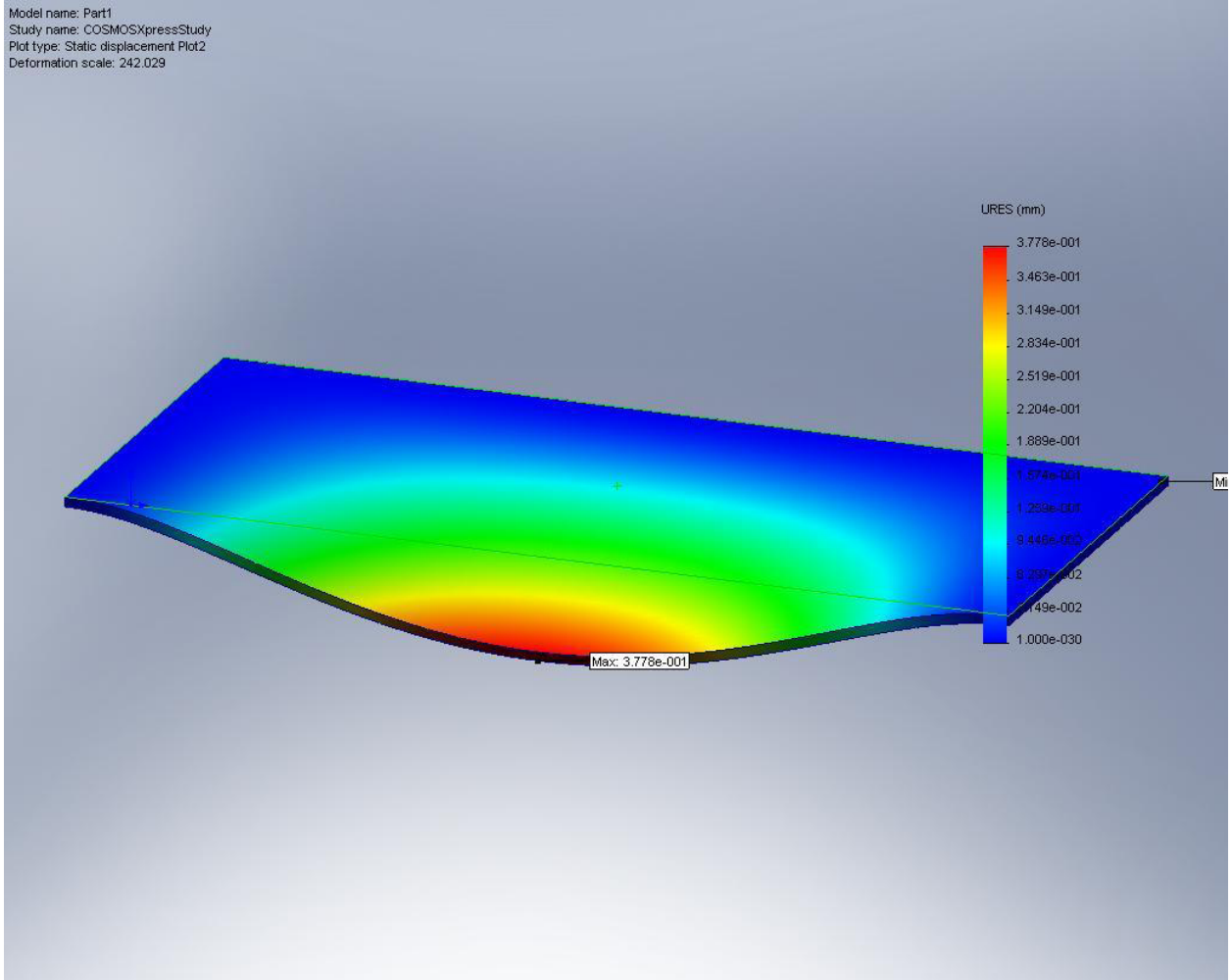

Aluminum 1060 Alloy .5 inch sheet displacement

Model name: Part1
Study name: COSMOSXpressStudy
Plot type: Static displacement Plot2
Deformation scale: 571.565

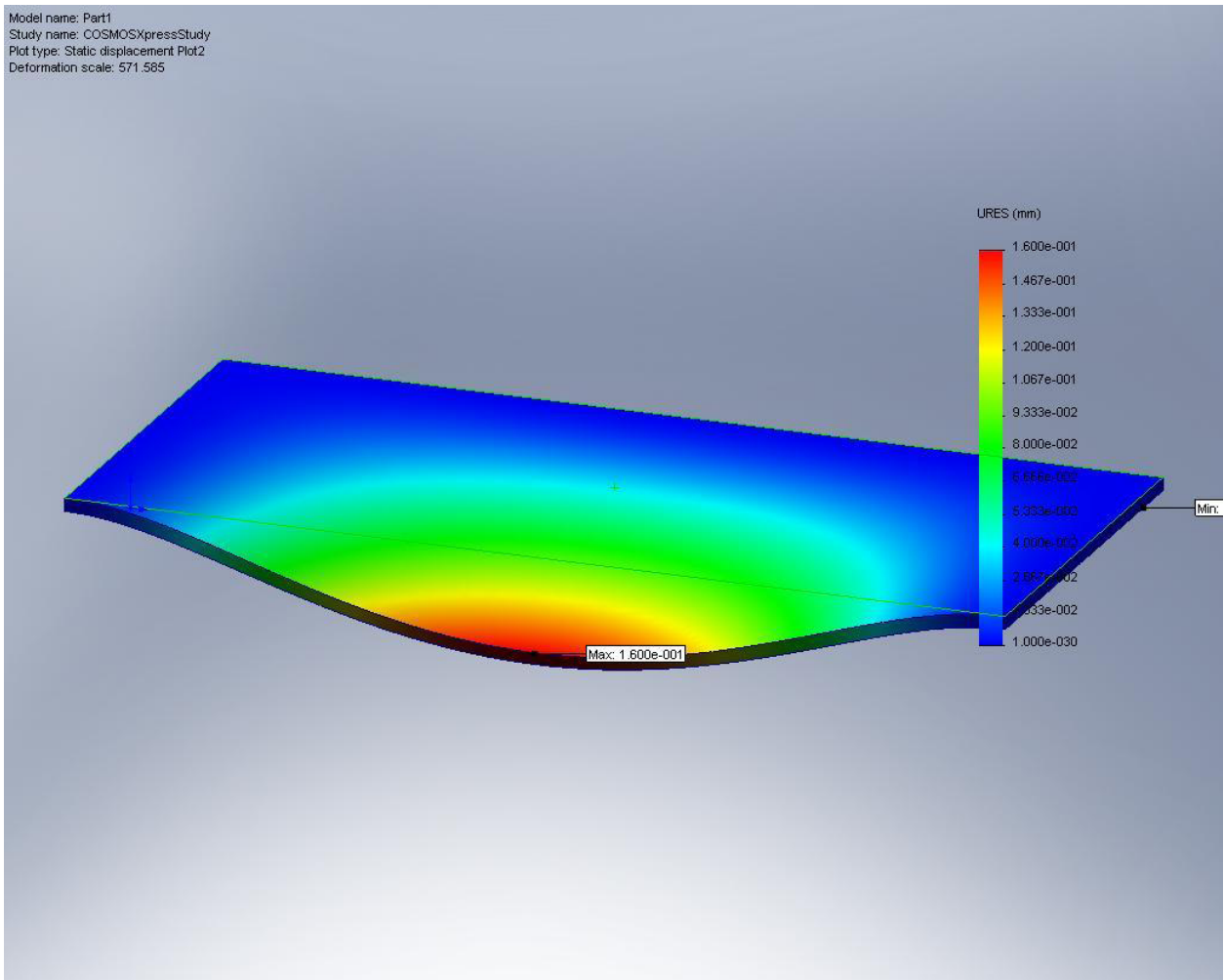

Wood .125 in sheet displacement

Model name: Part1
Study name: COSMOSXpressStudy
Plot type: Static displacement Plot2
Deformation scale: 0.391437

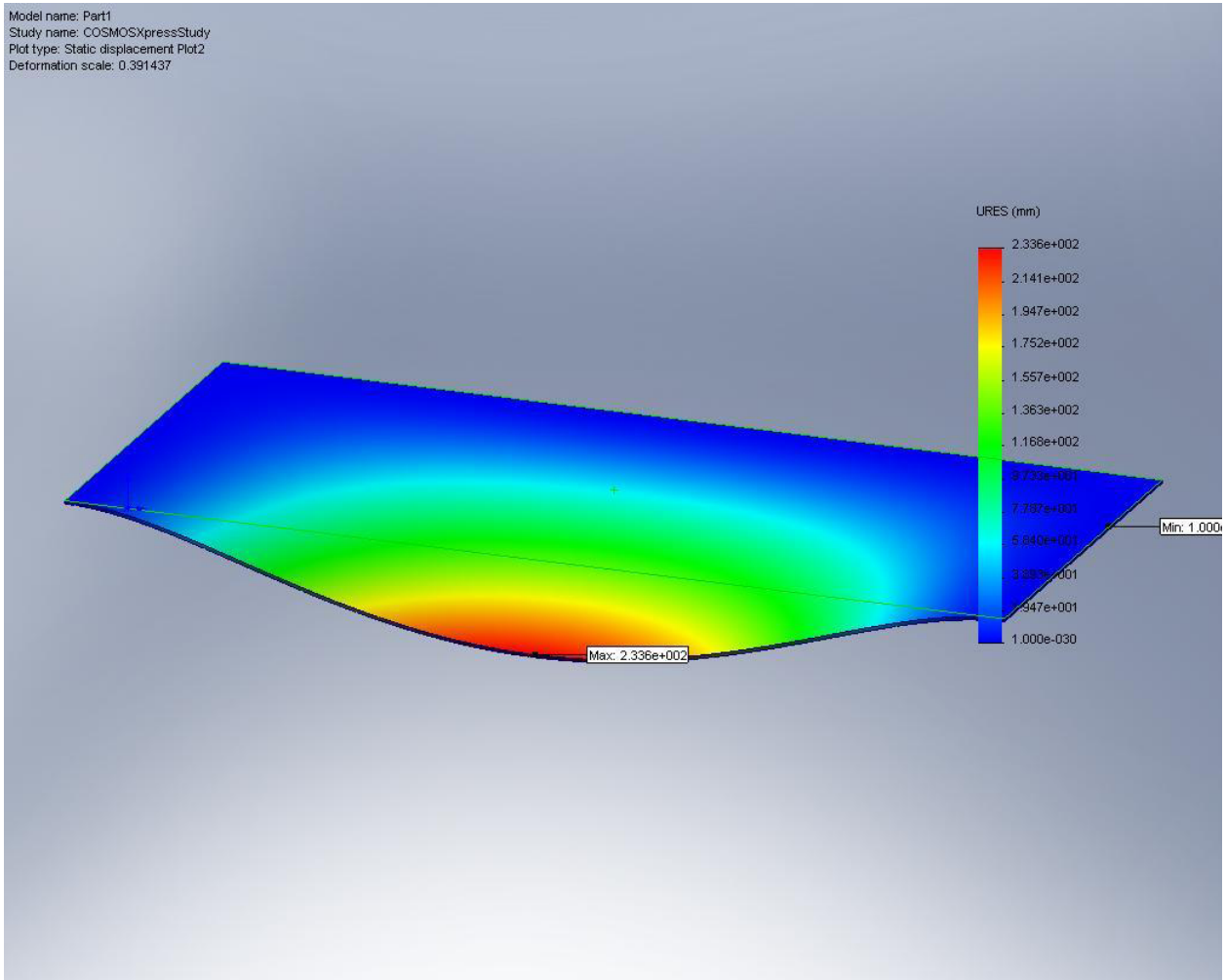

Wood .25 in sheet displacement

Model name: Part1
Study name: COSMOSXpressStudy
Plot type: Static displacement Plot2
Deformation scale: 3.11949

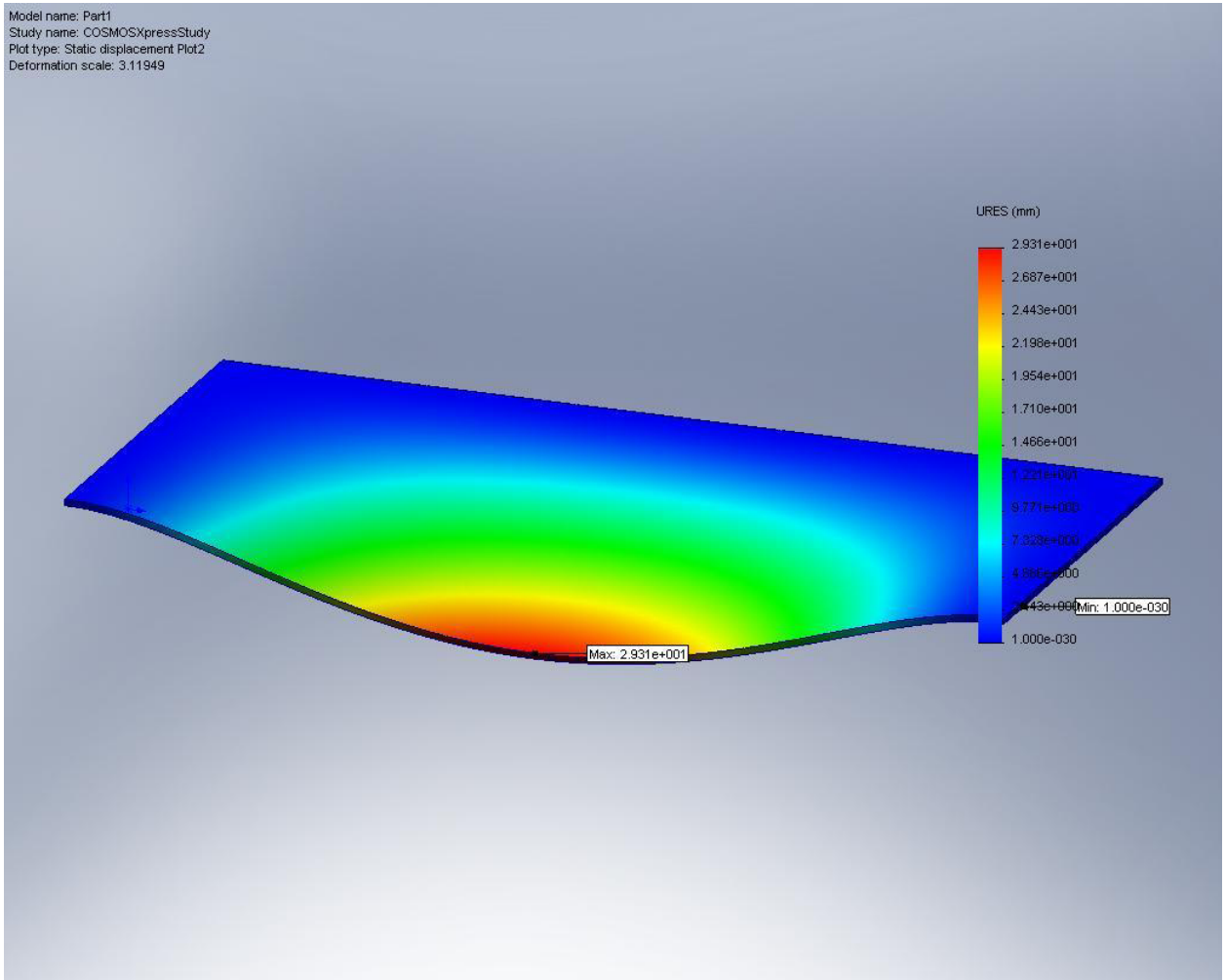

Wood .375 in sheet displacement

Model name: Part1
Study name: COSMOSXpressStudy
Plot type: Static displacement Plot2
Deformation scale: 10.5022

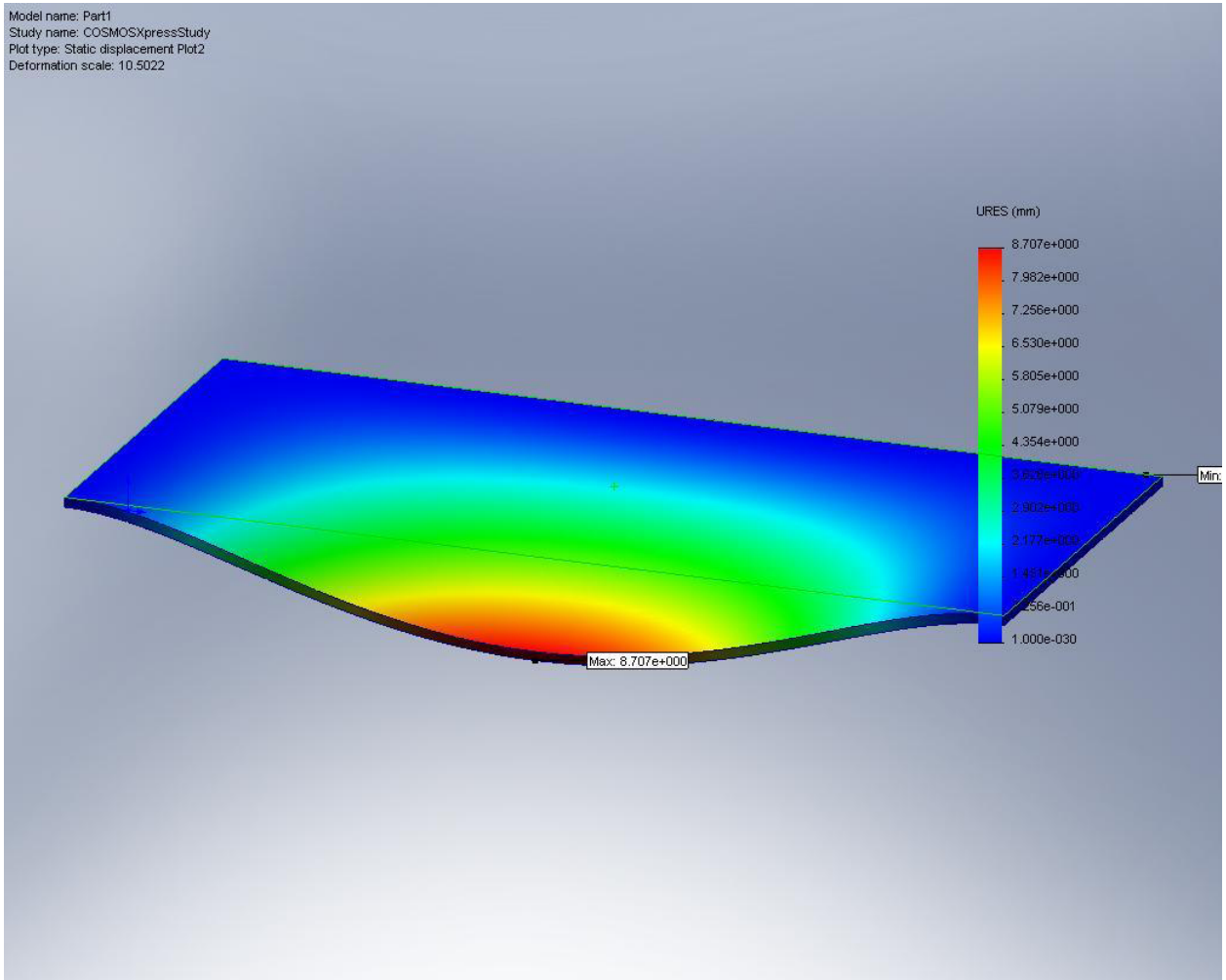

Wood .5 in sheet displacement

Model name: Part1
Study name: COSMOSXpressStudy
Plot type: Static displacement Plot2
Deformation scale: 24.8033

