

An Assistive Dumbbell Machine

A Major Qualifying Project Report:

submitted to the Faculty

of the

WORCESTER POLYTECHNIC INSTITUTE



in partial fulfillment of the requirements for the

Degree of Bachelor of Science

by

Robert Evers, Joseph McGeoghan, Vincent Milano, Andrew Sides, Michael Toto

Date: April 30, 2009

Professor Christopher A. Brown, Advisor

Abstract

When performing bench press, incline bench press and military press, weightlifters use large muscles. Strain or injury in smaller muscles is common among weightlifters when moving the dumbbells into the position required for these lifts. The objective of this project was to design a machine which would move the dumbbells into the required position needed to perform each of these lifts without the unwanted use of small muscles. Presently, there are three separate devices with no moving parts required for each of the three lifts. We wanted to design a machine which allows the user to adjust one machine to each position required by the three lifts. To accomplish this we used axiomatic design to match functions with features and avoid coupling. We used SolidWorks to build a solid model of our machine and FEA to test the solid model. EMG testing was used to prove the current method of moving dumbbells causes unwanted usage of small muscles. We designed a machine where before the user sits they will adjust the bench and the dumbbell holders for the desired lift, they will then load the dumbbells and then using a foot lever move the dumbbells into to the position required by the user to perform the lift. Our machine avoids the unwanted use of small muscles and allows the user to perform three exercises on one machine.

Table of Contents

Abstract	2
Table of Contents	3
Table of Figures	4
Introduction.....	6
Objective	6
Rationale.....	6
State-of-the-Art	14
Approach	16
Design Decomposition and Constraints.....	16
Axiomatic Design.....	16
Constraints and Customer Needs	17
Functional Requirements.....	18
Design Parameters and Physical Integration.....	24
Design Matrix.....	33
Prototype Production	35
Testing of the final design.....	38
Design Discussion.....	46
Bench Design	46
Dumbbell Support Design.....	47
Design 1, Pulley System with Rotational Arms.....	49
Design 2, Pulley System with Forward Moving Arms	51
Assessment of Design Method.....	54
Concluding Remarks.....	54
References.....	56
Appendix 1 – Online Forums.....	57
Appendix 2 – U.S. Patents	60
Appendix 3 – Variety of Benches.....	65
Appendix 4 – Variety of Dumbbells.....	67
Appendix 5 – Part Plans.....	69

Table of Figures

Figure 1 - Shoulder Press (coopersguns.com)	9
Figure 2 - Incline Press (coopersguns.com).....	9
Figure 3 –Flat Press (coopersguns.com).....	10
Figure 4 - Current Method (ExRx.net)	10
Figure 5 – Biceps (Tuliszka, 2008).....	12
Figure 6 - Lower Back (Robinovitch, 2008).....	13
Figure 7 - Axiomatic Decomposition in Acclaro.....	19
Figure 8 - Complete Solid Model	24
Figure 9 - DP1.1 and DP1.2.....	25
Figure 10 - DP2.1 and DP2.2.....	26
Figure 11 - DP2.1.....	27
Figure 12 - DP3.1.....	28
Figure 13 - DP3.2.....	28
Figure 14 - DP3.3 and DP3.4.....	29
Figure 15 - DP4.1.1, 4.1.2 and 4.1.3.....	31
Figure 16 - DP4.2 and DP4.3.....	32
Figure 17 - DP6.....	33
Figure 18 - Design Matrix.....	34
Figure 19 - COSMOSXpress of Back Rest Adjuster.....	38
Figure 20 - Incline Press Using Current Method.....	41
Figure 21 - Incline Press Using Assistive Machine	42
Figure 22 - Shoulder Press Using Current Method.....	43
Figure 23 - Shoulder Press Using Assistive Machine.....	44
Figure 24 - Bench Pad Support Design.....	47
Figure 25 - Dumbbell Holders	48
Figure 26 - Support FEA Image.....	49
Figure 27 - Design 1	50
Figure 28 - Design 1 Arm Spool.....	51
Figure 29 - Design 2	52
Figure 30 - Design 2 Functioning	52
Figure 31 - John Stone Fitness Forum	57
Figure 32 - Testosterone Nation Forum.....	58
Figure 33 - stronglift.com Forum.....	59
Figure 34 - US Patent 5411459 Dumbbell Rack Attachment.....	60
Figure 35 - US Patent 5472397 Retractable Dumbbell Support Bench.....	61
Figure 36 - US Patent 6149556 Multilevel Dumbbell Support Apparatus.....	62
Figure 37 - US Patent 7001314 Dumbbell Spotter	63
Figure 38 - US Patent 6436016 Dumbbell Suspension System.....	64
Figure 39 - Commercial 0-90 Degree Bench.....	65

Figure 40 - York Barbell Bench.....	65
Figure 41 - RockSolid Fitness Bench	66
Figure 42 - GPR Pro Style Rubber Dumbbell	67
Figure 43 - Cap Barbell Dumbbell.....	67
Figure 44 - Bowflex Select Tech 1090 Dumbbells.....	68

Introduction

Objective

This project set out to design a user-friendly device that promotes the utilization of specific muscle groups during the dumbbell flat bench press, incline press, and shoulder press exercises. Such a machine would lessen strain on untargeted muscles, reduce injuries, and optimize the user's workout.

Rationale

The realization of the need for such a machine has come from our own weightlifting experiences and the same need has been voiced through different weightlifting forums across the internet demanding a device similar to our design. The posts from three different users on three different weightlifting forums are shown below. For forum screenshots refer to Appendix I.

One user on the John Stone Fitness Forum (April, 2006) states:

“I recently switched to dumbbells, and have actually found that I get much better results than with the barbell. My chest is showing better definition than it ever has. I now want to move on to heavier dumbbells (to 60 lb from 50 lb) but I foresee a problem "getting into position". I can easily bench press far heavier weight than I'm doing now, but I find getting into the bench press position difficult even with the weight I'm on now. What I currently do is pick up the dumbbells, sit on the bench, curl the dumbbells, and then lay back while moving the dumbbells into the bench press position. This puts a lot of strain on my lower back and abs, and I don't think it's a good idea to do it with more weight.”

One user on the Testosterone nation forum states (March, 2009):

“As the weight is going up I’m having trouble positioning the dumbbells on the flat bench. I tried doing 100lbs using my old method where I just have the dumbbells on the floor in front of me and I swing them up to my knees while I’m in the seated position. I then just lean back and start pressing and drop them from a low height when I’m done. This is getting harder and I feel like I’m gonna throw my arm and shoulder out as I’m swinging them up to my knee.”

One user on the Stronglift.com forum states (Oct., 2008):

“I can somewhat easily do 70lb dumbbell bench press. I pick the dumbbells up from the floor while sitting on the bench and then swing them up. The main problem is after finishing the set. At that point, it is hard to sit back up and then set dumbbells down instead I try to let them down gently to the sides while I am still laying down. This puts my arms in an awkward position that seems like I am risking injury.”

As shown above it is clear that a machine or better method is necessary to provide an easier way to perform such exercises which is what this designed machine is set out to achieve.

Description of Exercises and Muscles Used

The three exercises to be done on this machine include the dumbbell shoulder press, incline press, and flat bench press. Table 1 explains the preparation and execution of each exercise (Clover, 2001).

Exercise	Preparation	Execution
Shoulder Press	Sit down on vertical bench and position dumbbells to each side of shoulders with elbows below wrists.	Press dumbbells until arms are extended overhead. Lower and repeat.
Incline Press	Sit down on incline bench with dumbbells resting on lower thigh. Kick weights to shoulders and lean back. Position dumbbells to sides of chest with upper arm under each dumbbell.	Press dumbbells up with elbows to the sides until arms are extended. Lower weight to sides of the upper chest until slight stretch is felt in chest. Repeat
Flat Press	Sit down on bench with dumbbells resting on lower thigh. Kick weights to shoulder and lie back. Position dumbbells to sides of chest with bent arm under each dumbbell	Press dumbbells up to sides until arms are extended. Lower weight to sides of the upper chest until a slight stretch is felt in the chest. Repeat

For each of these three exercises there are a set of target muscles, synergists, dynamic stabilizer muscles, and stabilizer muscles that are used while performing the exercise. The target muscles are the primary muscles intended to be used for the exercise. Synergist muscles are muscles that assist the target muscles in accomplishing the exercise. Dynamic stabilizers assist in joint stabilization by countering the rotator force of an agonist and occur during many compound movements. A stabilizer muscles is a muscle that contracts with no significant movement to maintain a posture or fixate a joint. Table 2 shown below displays these muscles for each of the three exercises (Clover, 2001) followed by Figures 1, 2, and 3 which provide visual representations of the targeted and synergistic muscles used in each exercise.

Exercise	Target	Synergists	Dynamic Stabilizers	Stabilizers
Shoulder Press		Deltoid (Lateral)	Triceps (Long Head)	Upper Trapezius
		Supraspinatus	Biceps Brachii	Levator Scapulae
		Trapezius (Middle, Lower)		
		Serratus Anterior		
		Pectoralis Major (Clavicular)		
		Triceps Brachii		
Incline	Pectoralis	Deltoid (Anterior)	Biceps Brachii	

Press	Major (Clavicular)		(Short Head)	
		Triceps Brachii		
Flat Press	Pectoralis Major (Sternal)	Anterior Deltoid	Biceps Brachii (Short Head)	
		Triceps Brachii		
		Pectoralis Major (Clavicular)		

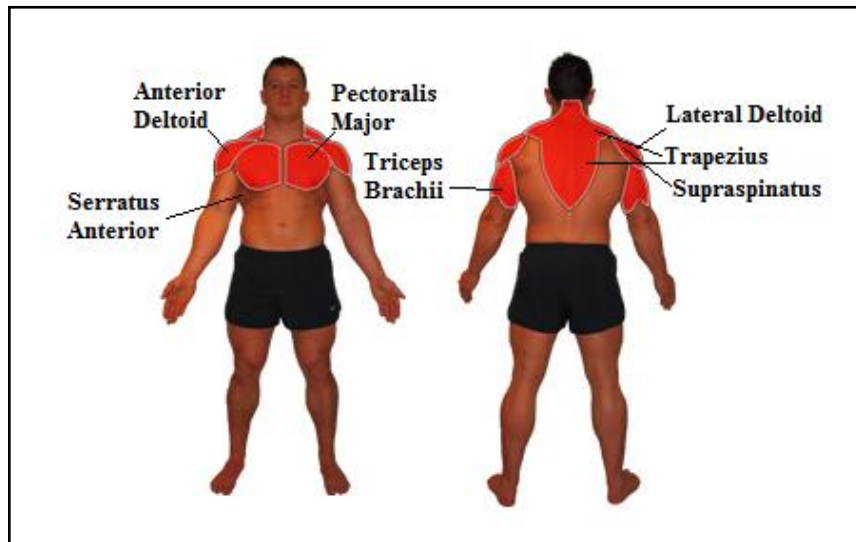

Figure 1 - Shoulder Press (coopersguns.com)

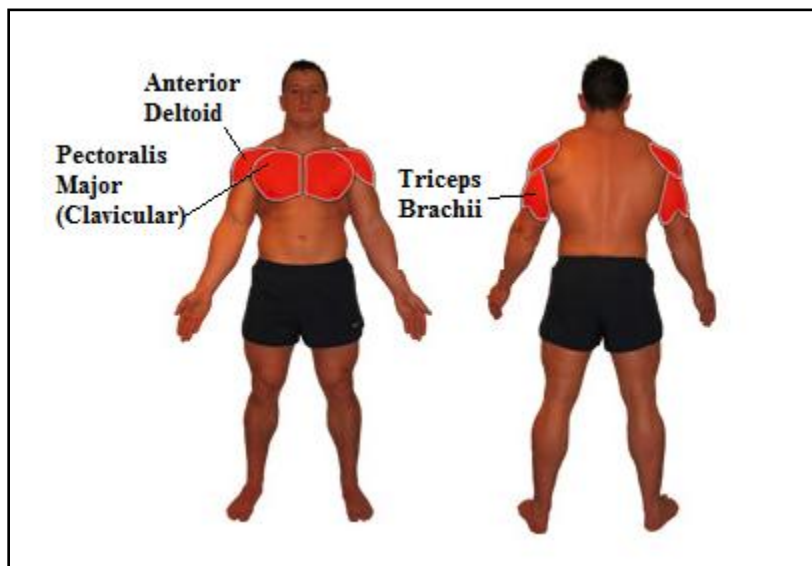

Figure 2 - Incline Press (coopersguns.com)

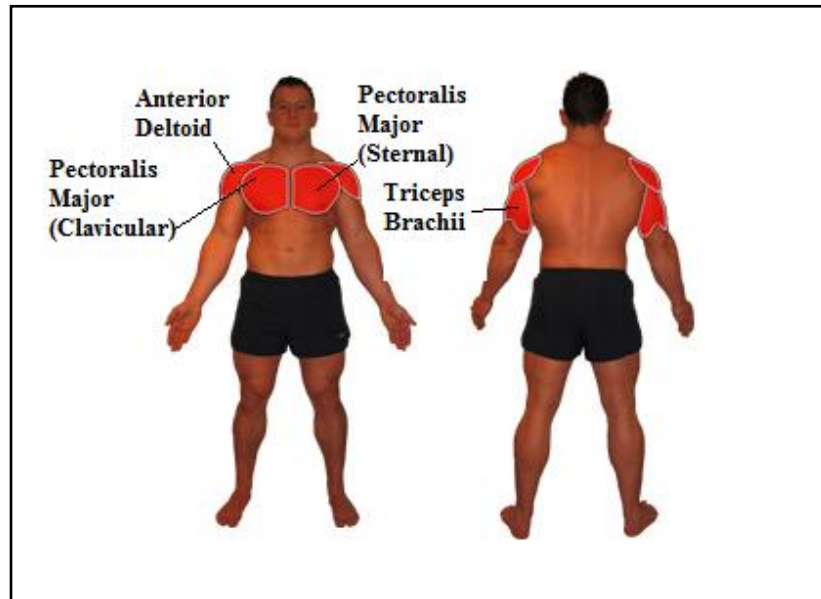

Figure 3 - Flat Press (coopersguns.com)

Problem with current method

The problem with the current method of performing these exercises is the process of getting the dumbbells to the ‘ready position’ for the exercise and then placing the weights back onto the floor after the exercise is performed. The current method shown in Figure 4 consists of lifting the dumbbells from the ground, onto the knees, and kicking them up to the shoulders (ready position) for the exercise.

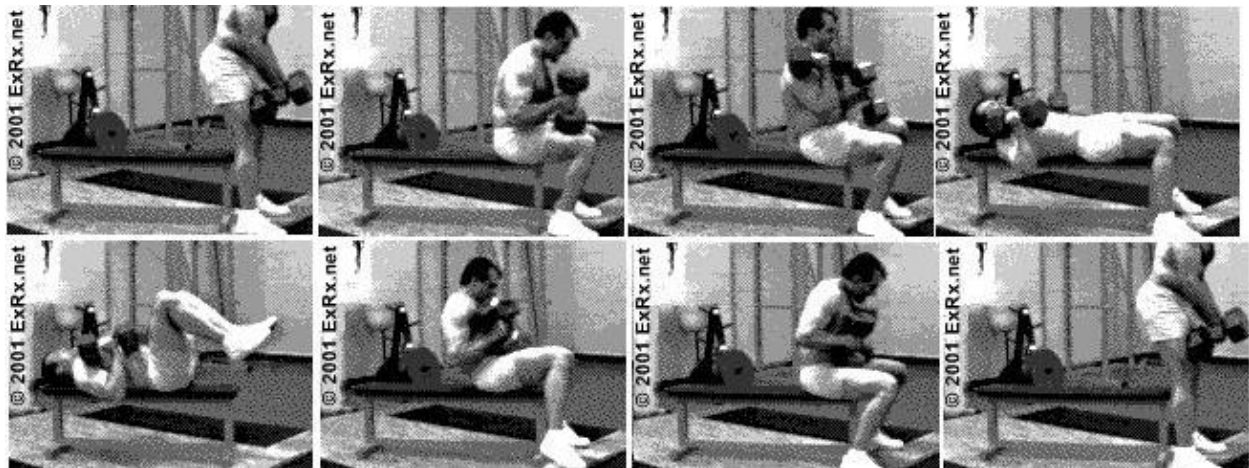

Figure 4 - Current Method (ExRx.net)

This becomes an issue when increasing weight because it becomes more difficult to lift the dumbbells from the ground and kick them up to the ready position causing strain in muscles of the lower back, forearm, bicep, and shoulder which can ultimately lead to injury. This process also takes away from the user's actual workout by forcing them to exert energy from untargeted muscles to get the weight ready for the exercise. Also some users cannot reach peak performance due to their inability to reach the lifting position at higher amounts of weight. Eliminating this step will allow the user to reduce their risk of injury, to concentrate on the actual exercise and optimize their performance.

Strengths of Un-targeted Muscles

As described above, the current method of getting dumbbells into the 'ready position' can result in injury as the user increases weight, based on the fact that the maximum amount of tension in the untargeted muscles is exceeded. According to Tulaszka (2008) the maximum tension exerted by a muscle is about 50 N/cm² of cross section. Using Equation (1), the maximum tension (T) exerted by the biceps and lower back (erector spinae) can be determined by multiplying 50 N/cm² by the average cross sectional areas (S) of each muscle.

$$T = 50 \text{ N/cm}^2 \times S \quad [1]$$

Below shows representative diagrams of the bicep and the muscles of the lower back (erector spinae) at different points of the current method of getting the dumbbells in position. Each diagram uses average values of limb length from pivot (r_{Load}), muscle attachment from pivot (r_{muscle}), angle of muscular attachment, muscle cross section, and assumes the load to be acting at 90°. For each diagram we performed a calculation (using Equation (2) shown below)

based on the maximum tension each muscle can withstand (T) and under a 100lb load, a commonly used weight in such exercises.

$$F_{Load} = (r_{muscle} \times T \times \sin(\text{Angle of attachment})) / (r_{Load} \times \sin(\text{Angle of load})) \quad [2]$$

Figure 5 shows the biceps at the point of lifting the dumbbells from the ground right before placing them onto the knees assuming muscles of the forearm are at equilibrium.

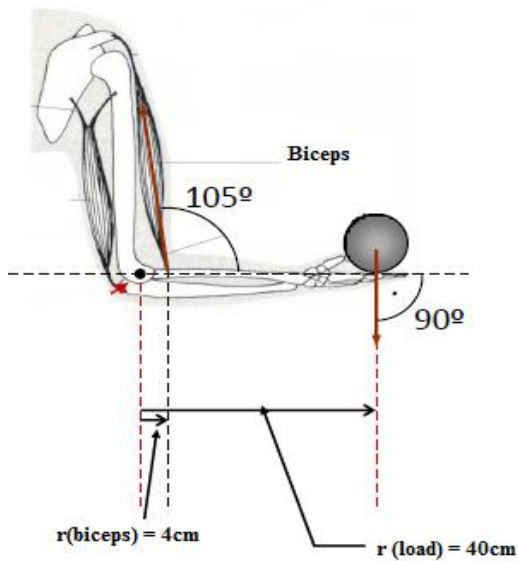

Figure 5 – Biceps (Tuliszka, 2008)

For maximum Tension in biceps:

S=50 cm² (Tuliszka, 2008)

Equation (1)

$$T = 50 \text{ N/cm}^2 \times 50 \text{ cm}^2 = 2500 \text{ N}$$

For maximum load on biceps:

Equation (2)

$$F_{Load} = (.04 \text{ m} \times 2500 \text{ N} \times \sin 105^\circ) / (0.40 \text{ m} \times \sin 90^\circ)$$

$$F_{Load} = 240 \text{ N} = 54 \text{ lbs}$$

Under 100lb (444.8N)

Equation (2)

$$444.8 \text{ N} = (.04 \text{ m} \times T \times \sin 105^\circ) / (0.40 \text{ m} \times \sin 90^\circ)$$

$$T = 4633 \text{ N}$$

Figure 6 shows the muscles of the lower back at the point of lifting the dumbbells from the ground just before sitting to place on the knees.

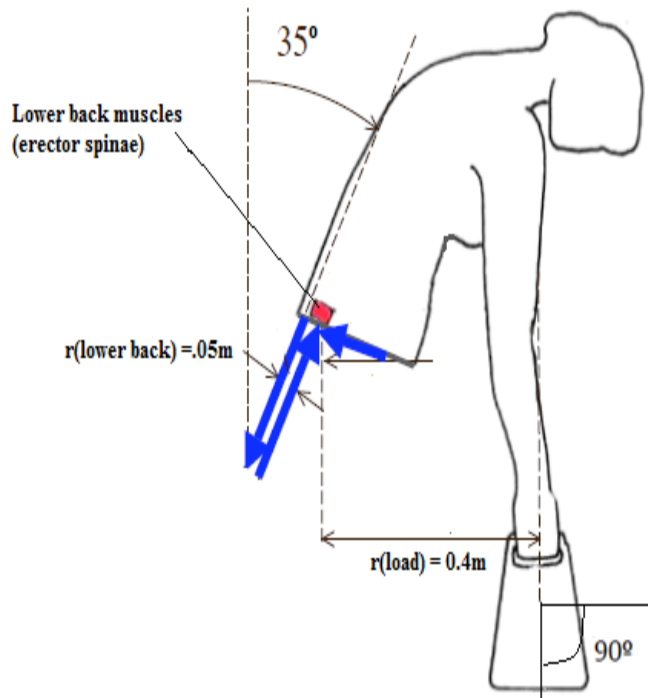

For maximum Tension in lower back:
S=1.6 cm² (Robinovitch, 2008)
Equation (1)
 $T = 50 \text{ N/cm}^2 \times 1.6 \text{ cm}^2 = 80 \text{ N}$

For maximum load on biceps:
Equation (2)
 $F_{\text{Load}} = (.05 \text{ m} \times 80 \text{ N} \times \sin 30^\circ) / (0.4 \text{ m} \times \sin 90^\circ)$
 $F_{\text{Load}} = 5 \text{ N} = 1.2 \text{ lbs}$

Under 100lb (444.8N)
Equation (2)
 $444.8 \text{ N} = (.05 \text{ m} \times T \times \sin 35^\circ) / (0.40 \text{ m} \times \sin 90^\circ)$
 $T = 6203 \text{ N}$

Figure 6 - Lower Back (Robinovitch, 2008)

As seen above in Figures 5 and 6 the maximum loads each muscle can take is greatly exceeded in both cases under a load of 100lbs. For this reason a machine that would eliminate the current method of placing the dumbbells to the ready position would immensely reduce the load on the weaker muscle groups thereby reducing injury.

Electromyography (EMG) testing

EMG testing was used to analyze the activation of the non-targeted muscles, which are common in injury, when lifting dumbbells to the ready position while comparing the activation of these muscles when our assistive dumbbell machine is used.

EMG analysis has been used in the past to record muscle activation. Newton et al. (1996) used EMG to analyze the activation of the chest muscles when a subject performed weighted chest throws before and after muscle stretching. Sarti et al. (1996) used EMG to analyze the difference in activation of the abdominal muscles in two different abdominal exercises. Following test protocol from these experiments our testing was performed.

State-of-the-Art

The current state of the art for machines or devices set out to accomplish the objective of our designed machine have some potential advantageous ideas but have many deficiencies that are improved upon by our machine. Table 3 shown below shows each of the names and patent numbers of current machines, the description of each machine, advantages of each, and the deficiencies of each. Pictures of each device can be seen in Appendix II.

Name and Patent Number	Description	Advantages	Design Deficiencies
<p>Dumbbell Rack Attachment</p> <p>U.S. Patent 5411459</p>	<p>A dumbbell rack attachment to be inserted into the column of an exercise weight bench.</p>	<p>User friendly design of dumbbell rack</p>	<p>Does not allow for rack to move out of the user's way during exercise</p> <p>Can only be used in machines with an open column</p>
<p>Retractable Dumbbell Support Bench</p> <p>U.S. Patent 5472397</p>	<p>An exercise bench equipped with pivoting racks that swing dumbbells into position by use of a foot lever</p>	<p>Allows for returning the racks to start position and out of the way of the user during exercise</p>	<p>Safety concerns dealing with the swinging of the dumbbells</p> <p>Manufacturability of the small moving components is an issue</p>
<p>Multilevel Dumbbell Support Apparatus</p> <p>U.S. Patent 6149556</p>	<p>A support apparatus equipped with dumbbell racks to be used in conjunction with an exercise bench.</p>	<p>Allows for adjustable heights for dumbbells</p>	<p>Does not provide an exercise bench</p> <p>Does not allow for the rack to move out of the user's way during exercise</p>
<p>Dumbbell Spotter</p> <p>U.S. Patent 7001314</p>	<p>A weightlifting apparatus for supporting a dumbbell and loading it from a lower position and manually cranking the weight to the user's desired height.</p>	<p>Allows for dumbbells to be loaded at a lower position</p>	<p>Hand crank apparatus raises concerns in user friendliness and manufacturability</p> <p>Does not provide exercise bench</p> <p>Bulky design</p>
<p>Dumbbell Suspension System</p> <p>U.S. Patent 6436016</p>	<p>Specially designed hooks that are mounted on a weight bench for suspension of dumbbells having attached handles.</p>	<p>Allows for use with multiple types of dumbbells</p>	<p>Does not allow for the hooks to move out of the user's way during exercise</p>

Approach

The approach used in designing this machine was to use the advantageous aspects of the prior art and improve upon the deficiencies noted in the prior art. The design of this machine provides an exercise bench and allows for multiple bench angles 90°, 45°, and flat. This allows multiple exercises to be done on a single machine. The design of the dumbbell racks for this machine allows for multiple types of dumbbells to be used to allow for multi-functionality. The racks and arms the dumbbells are placed onto are designed to move the dumbbell racks forward for dumbbell pickup and away during exercise by way of a foot-lever pulley system. The design also allows for adjustable heights for dumbbell placement to allow users of different sizes to comfortably use the machine.

The team designed, manufactured, and tested the machine. The design of the machine was modeled using SolidWorks and the Finite Element Analysis of the materials (FEA) was done using COSMOSXpress. The machine was manufactured using the Higgins Laboratories machine lab. Once the prototype was manufactured, EMG testing was done to prove the effectiveness of the machine and the three exercises were performed to determine the user-friendliness and the efficiency of the machine.

Design Decomposition and Constraints

Axiomatic Design

We used axiomatic design to satisfy every element of our design and help keep each of these elements organized and specific. Axiomatic design works by listing Functional

Requirements, labeled FR, and matching them with Design Parameters, labeled DP, based on customer needs and constraints. It also allows you to prevent the coupling of functions. The functional requirements explain what your design must be able to accomplish. You list these starting with a top level FR, this is the main goal of the design, and break it down into lower level FR's getting more specific with each level. When all of the Functional Requirements are listed you then match a Design Parameter to each one. (Suh, 1990)

Constraints and Customer Needs

Our top level Functional Requirement was to provide a machine to move dumbbells safely. When developing our design we needed to follow economic, safety, manufacturing and functional constraints.

The economic constraints were based around the allotted amount of money given to us by the mechanical and biomedical engineering departments. Therefore, we needed to design our prototype around inexpensive materials or a material which we could find in the stock room of the Higgins Lab.

A main intent of the project was to eliminate injuries and thus improve the safety of performing dumbbell lifts and our machine needed to be on par with this. Every aspect of the design must be robust enough to withstand the forces exerted on it in a number of different ways. If our machine was unsafe in any way it contradicts its most important purpose.

The final constraint dealt with manufacturability. In order for us to build a prototype we needed to design around the constraints of manufacturing it on campus. The machines on campus must be able work with the materials we selected in our design and the process needed to build each part had to be feasible.

In order for our machine to be considered for use by anyone its functionality needed to be user friendly. If the person using our machine is either unable to understand how to use it or is physically unable to use it then it will not be used. Therefore, all sizes of people had to be considered in the design of our machine.

Functional Requirements

The main Functional Requirement is to provide a machine to move dumbbells safely. This top level FR is broken down into a series of progressively more specific FR's through a decomposition. The top level FR is decomposed into more specific lower level FR's. To organize our decomposition we separated the second level FR's into categories based around the various aspects the design needed to function. We then decomposed each second level FR into the directions of support or movement needed to accomplish each aspect. The decomposition also allows us to ensure the design is both collectively exhaustive and mutually exclusive. This means all of the FR's meet every need of the overall design but two FR's do not accomplish the same thing. Figure # is an axiomatic decomposition table of our design done in Acclaro.

#	[FR] Functional Requirements	[DP] Design Parameters
0	FR Provide a machine to move dumbbells safely	DP Device for safely moving dumbbells
1	FR provide user stabilization	DP device for user stabilization
1.1	FR provide user rolling stabilization	DP Pads to provide user rolling stabilization
1.1.1	FR provide support for lower half of user	DP pad to support lower half of user
1.1.2	FR provide lower pad stabilization	DP structure to support lower pad
1.1.3	FR provide support for upper half of user	DP pad to support upper half of user
1.1.4	FR provide upper pad stabilization	DP structure to support upper pad
1.2	FR provide user vertical support	DP device for user vertical support
1.2.1	FR provide vertical support for lower pad	DP device to vertically support lower pad support structure
1.2.2	FR provide vertical support for upper pad	DP device for vertical support of upper pad
2	FR provide system to adjust user position	DP device to adjust user position
2.1	FR provide system to adjust user position on upper vertical support bar	DP device to adjust user position on upper vertical support bar
2.2	FR provide system to adjust upper vertical support bar on base	DP device to adjust upper vertical support bar on base
3	FR provide a device to securely hold dumbbells	DP device for holding dumbbells
3.1	FR provide dumbbell support	DP rack for dumbbell support
3.1.1	FR provide rolling support	DP walls for rolling support
3.1.2	FR provide vertical support	DP bottom for vertical support
3.2	FR provide support for rack	DP arm for rack support
3.2.1	FR provide horizontal and bending direction support	DP Rail around arm for horizontal and bending direction support
3.2.2	FR provide vertical direction support	DP Pin for vertical direction support
3.3	FR provide support for arm	DP base for arm support
3.3.1	FR Provide vertical support of arms	DP base for vertical support of arm
3.3.2	FR provide horizontal or bending support	DP back wall of base for horizontal or bending support
3.4	FR provide support for base	DP wheels to support base
4	FR provide system to adjust dumbbell supports	DP device to adjust dumbbell supports
4.1	FR provide system to adjust dumbbell supports horizontally	DP system to adjust dumbbell supports horizontally
4.1.1	FR provide system to utilize user force	DP foot lever to direct user force
4.1.2	FR provide system to transfer user force	DP pulley system to transfer user force
4.1.3	FR provide system to guide supports	DP rail/bar to guide supports
4.2	FR provide system to adjust dumbbell racks vertically along arms	DP rails to adjust dumbbell racks vertically along arms
4.3	FR provide system to lock rack to arm	DP pins to lock rack to arm
5	FR provide system to move dumbbell supports from exercise area	DP device to move dumbbell supports from exercise area
5.1	FR provide mechanism to pull dumbbell supports back	DP mechanism to pull dumbbell supports back
5.2	FR provide system to stop dumbbell supports	DP device to stop dumbbell supports
6	FR Provide system to assist user in loading dumbbells	DP step to assist user in loading dumbbells

Figure 7 - Axiomatic Decomposition in Acclaro (www.axiomaticdesign.com)

FR1 Provide User Stabilization

FR1 is to support the user in a comfortable manner. The user must be supported to perform the targeted lifts. We needed to support the user in two sections, one part to support their buttocks when sitting and another to support to their back when leaning back or laying down. We also had to take into consideration a certain level of comfort for the user. We separated this FR by splitting it into rolling and vertical support.

FR1.1 Provide User Rolling Stabilization

This is to adequately prevent the user from rolling off the support. It was broken down into four smaller FR's to allow for a pad to support the rolling of the user and a pad support to prevent the rolling of the pad for both the upper and lower parts of the user.

FR1.2 Provide User Vertical Support

The user must be supported from falling directly to the ground. This is the most basic of functions but also the most necessary. Without the ability to support the user vertically and allow them to sit or lay down, every other aspect of the design will be impossible to function.

FR2 Provide System to Adjust User Position

We wanted our design to be unique in the sense that it will allow the user to perform a variety of lifts. This sets our design apart from previous designs, such as which only allow for a single lift to be performed on a single machine. To do this we needed the back rest support bar to be adjustable in two different areas.

FR3 Provide a Device to Securely Hold Dumbbells

After the FR's required by the users were complete, we required a device to hold the dumbbells while the user gets into position. To accomplish this we needed to both properly support the dumbbells and allow the user space to grab the dumbbells.

FR3.1 Provide Dumbbell Support

We first needed a structure for the dumbbells to rest on, while allowing space for the user to grab the dumbbell in order to perform the lift. To properly support the dumbbell we had to prevent it from rolling and from falling directly to the floor much like the device needed to support the user.

FR3.2 Provide Support for Rack

With a device for the dumbbell to rest on, we needed a device to support this structure. This must be able to support the dumbbell holder from swaying in any direction or falling over and must prevent the dumbbell holder from falling directly to the ground.

FR3.3 Provide Support for Arm

The dumbbell arms which support the dumbbell holder must also be supported. This must be strong enough to prevent the arms from bending in any direction and from falling directly to the ground much like the dumbbell arms support the dumbbell holder.

FR3.4 Provide Support for Base

The final step in supporting the dumbbells is the supports which come in direct contact with the floor. These supports are needed solely to support the entire dumbbell support structure in the vertical direction.

FR4 Provide a System to Adjust Dumbbell Supports

With a device to securely support the dumbbells, we needed a device to allow the dumbbell supports to adjust for different exercises and people of different sizes. To do this we

decomposed FR4 into two children. One was to adjust the dumbbell supports horizontally and one to adjust them vertically.

FR4.1 Provide System to Adjust Dumbbell Supports Horizontally

The dumbbell supports need to be moved horizontally by the user specific to the desired exercise. Forces exerted by the user must first be directed and then transferred to the dumbbell supports to move them the correct distance. A system is needed to keep the dumbbell supports moving in the correct direction as well.

FR4.2 Provide a System to Adjust Dumbbells Supports Vertically along Arms

We need to account for the heights involved with different exercises and different sizes of people. A system must be designed to allow for the dumbbell holders to be adjusted vertically along the support arms.

FR4.3 Provide System to Lock Rack to Arm

A device is needed to lock the dumbbell holder in place for proper support after it has been adjusted to the position required by the user.

FR5 Provide System to Move Dumbbell Support from Exercise Area

The user will move the dumbbell holders and supports to the required position to remove the dumbbells for their lift. In order for the lift to be performed the dumbbell supports need to be removed from the exercise area.

FR5.1 Provide Mechanism to Pull Dumbbell Supports Back

A system is required to move the dumbbells supports from the exercise area after the user has removed the dumbbells from the dumbbell holders.

FR5.2 Provide System to Stop Dumbbell Supports

Without the dumbbell supports being stopped, as they are forced from the exercise area, they will collide with the supports of the bench. A device is needed to stop the dumbbell holders being forced out of the exercise area.

FR6 Provide System to Assist User in Loading Dumbbells

The dumbbell holders need to be adequately placed to allow for the height requirements of a user performing the shoulder press. The loading of the dumbbells onto the dumbbell holders would be hard for a shorter person or someone doing heavy dumbbells. Therefore, a device is needed to raise the location for the user during the loading of the dumbbells.

Design Parameters and Physical Integration

DP0 Device for Safely Moving Dumbbells

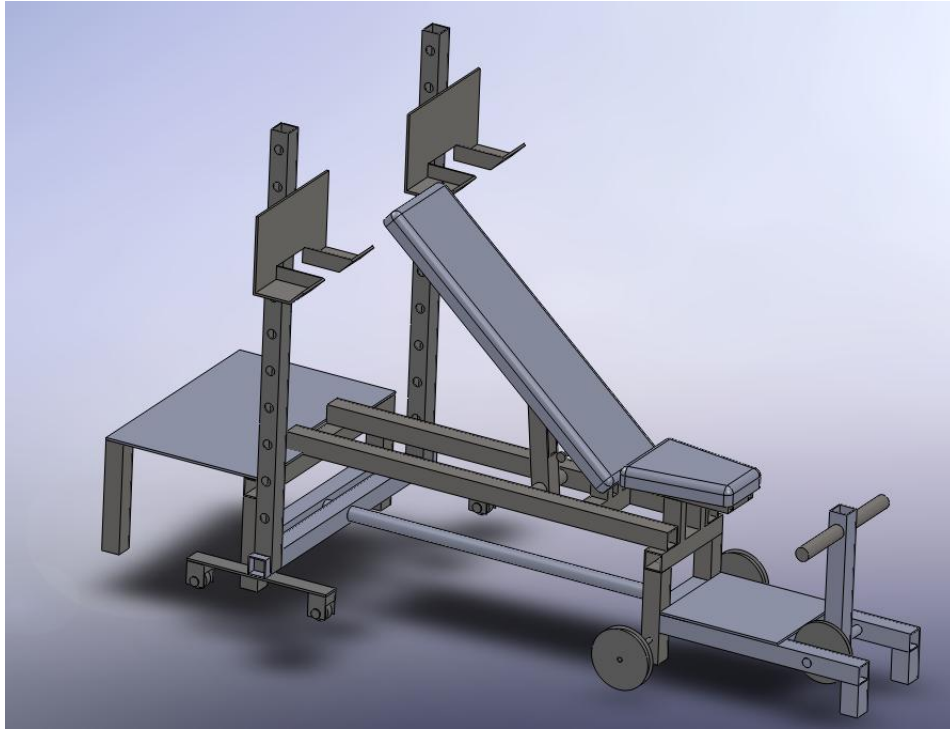

Figure 8 - Complete Solid Model

DP1 Device for User Stabilization

To provide user stabilization comfortably we used a generic pad made of foam attached to a sheet of plywood and covered with a synthetic material. This was taken from an existing bench for ease of use. There are two parts to this pad made of the same materials, one for the buttocks and one for the back as required by our design. These pads are then attached to steel support structures which will support the pads from rolling over with the user when they sit on it (DP1.1). To support the user in the vertical direction the pads and support structures are attached to a system of steel vertical supports (DP1.2).

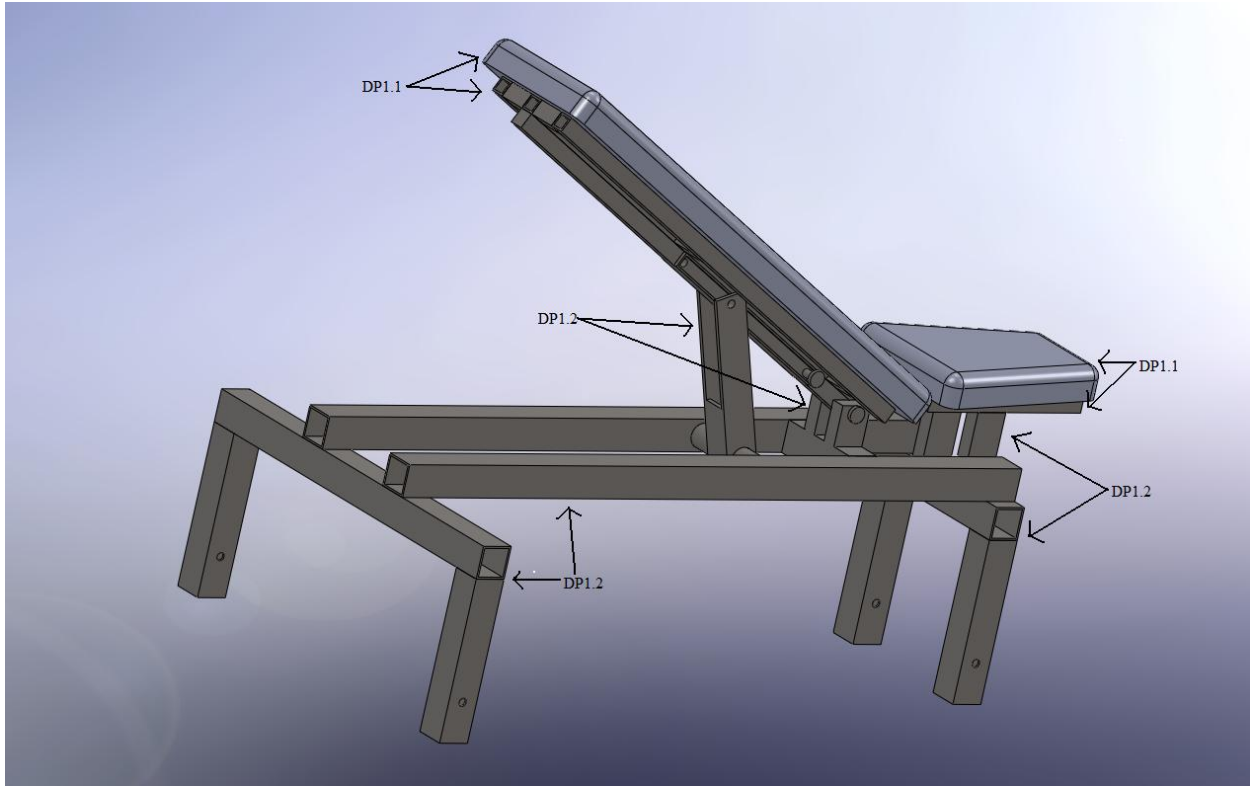

Figure 9 - DP1.1 and DP1.2

DP2 Provide System to Adjust User Position

To adjust the user position we needed to allow the vertical support of the back rest to move along the pad support structure and along the base of the support. On the base of the support it is simply supported by a round tube to allow the vertical support bar to rotate freely (DP2.2). The top of the back support bar needs to move freely along the pad support structure without coming dislodged (DP2.1). To do this a small circle is attached to the inside of the support bar. A rectangular box is attached to the pad support structure. The circle must be the correct size to fit snugly inside the rectangular box but be able to move freely. Holes are drilled through the support bar, circle piece and pad support structure to allow a pin to pass through. When the pin is placed through all parts it acts as a piece of the support system to provide vertical support to the user. When the pin is removed it allows the user to adjust the pad to the

desired position. When the user is in the process of adjusting the support the circle runs along the inside of the rectangular box to prevent the pad support structure from coming dislodged from the vertical support.

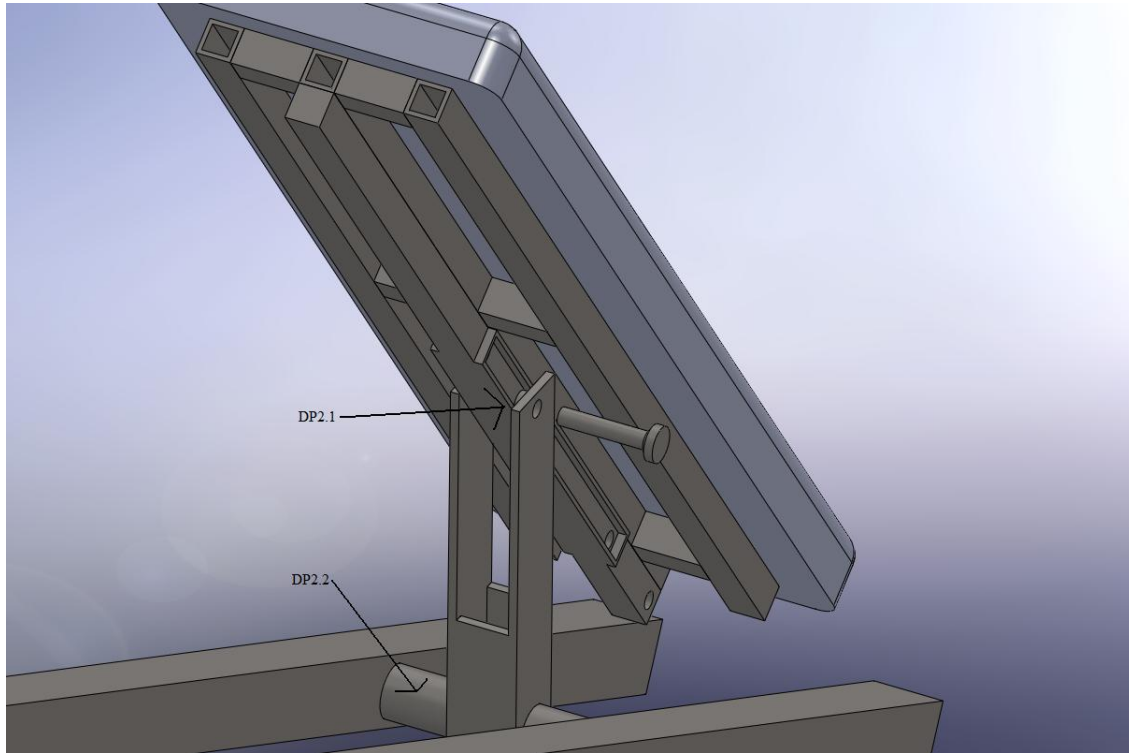

Figure 10 - DP2.1 and DP2.2

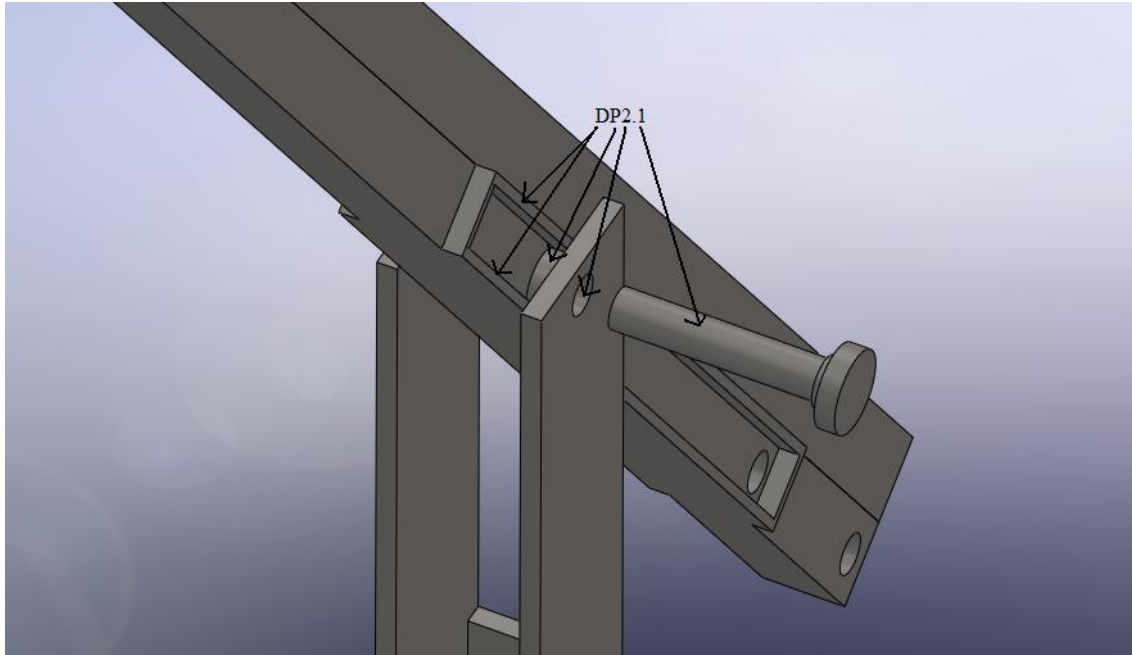

Figure 11 - DP2.1

DP3 Device for Holding Dumbbells

The dumbbells holders must be designed for dumbbells of various sizes but still provide support in each direction. The size of the base of the dumbbell holders must be large enough to of dumbbells. The walls of the dumbbells holders must prevent the dumbbells from rolling or sliding off. The walls to prevent the sliding of the dumbbells must allow for dumbbells of various lengths (DP3.1). A steel plate is cut to size of each wall piece and welded together to create the dumbbell holders.

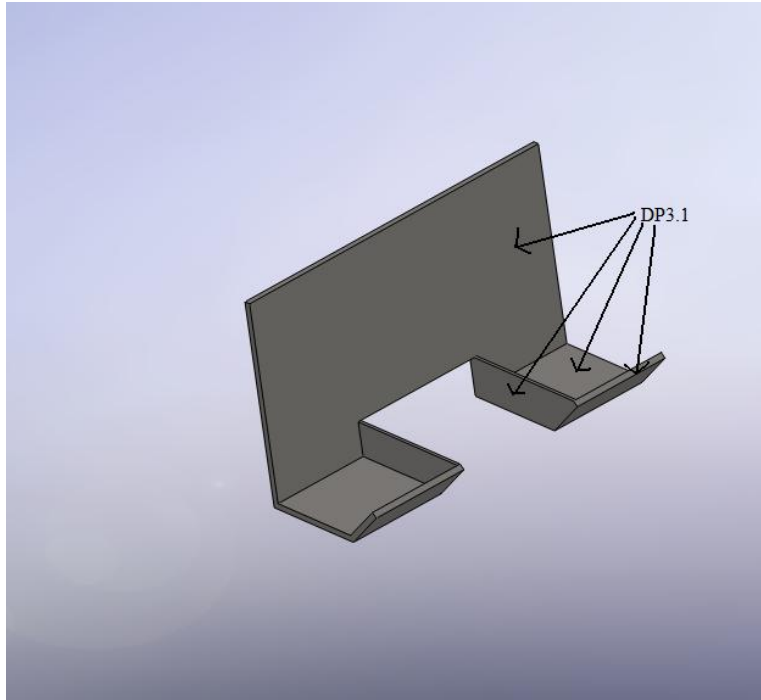

Figure 12 - DP3.1

The dumbbell holders are attached to steel square tubing standing vertically upright, these are the arms. This gives the proper height and strength to support the dumbbell holders in all directions. (DP3.2)

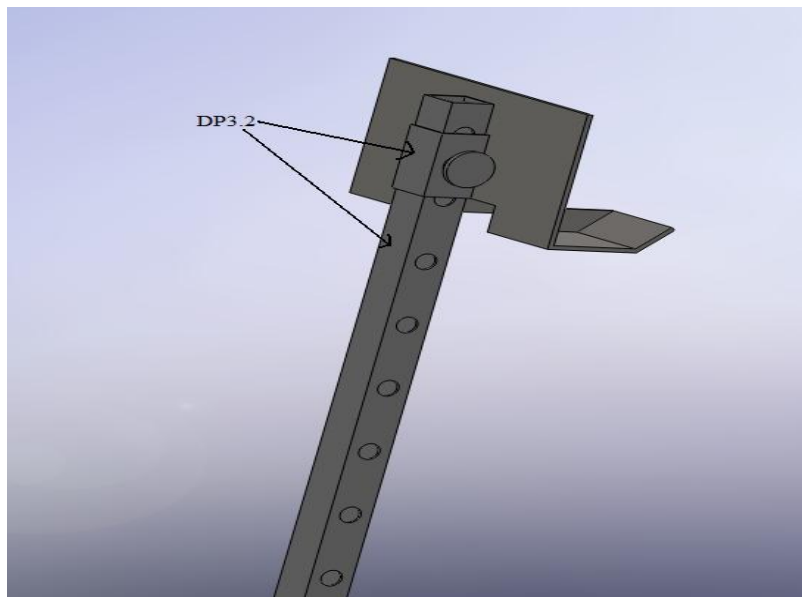

Figure 13 - DP3.2

The arms are then attached to a base made of steel square tubing. The square tubing of the base is cut to allow the base of the arms to fit into the tubing and the arms are then welded in place. The tight fit and welds will prevent the arms from swaying. The bottom of the base will support the arms vertically (DP3.3).

The base of the dumbbell support structure is supported on the ground by wheels. The wheels will give base support in the vertical direction (DP3.4). The wheels are to be generic wheels, found in a hardware store, with the ability to be welded on the bottom of the dumbbell supports base.

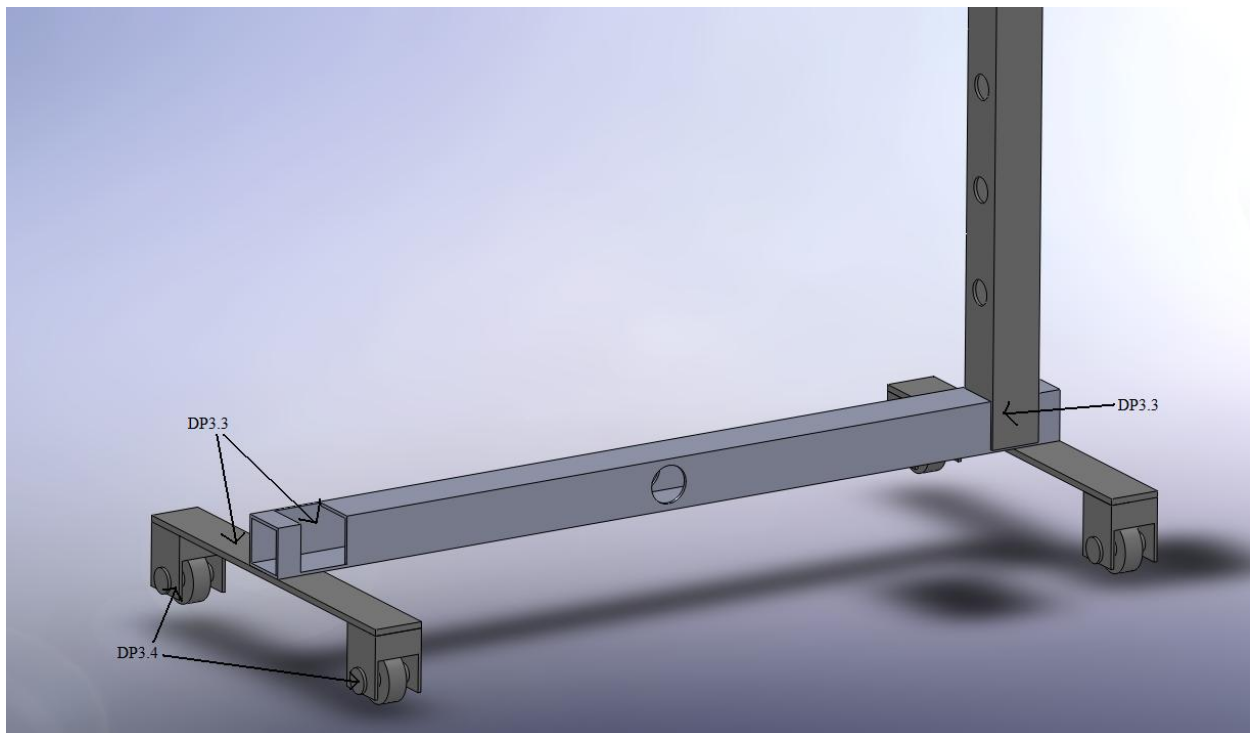

Figure 14 - DP3.3 and DP3.4

DP4 Provide System to Adjust Dumbbell Supports

Moving the dumbbells into position for each lift requires a force exerted by the user. A foot lever is used to direct the force exerted by the user (DP4.1.1). The foot lever is to be made out of available material as there are minimal stresses acting on it.

This force then needs to be transferred from the foot lever into the force required to move the dumbbell supports. A system of pulleys was designed to do this (DP4.1.2). The first step was to calculate the maximum distance the dumbbell supports need to travel (40in.). Next, we calculated the maximum rotation achieved from the user pushing the foot lever (80 degrees). We then calculated the sizes of pulleys needed to convert the 80 degrees of rotation into the 40in. of movement for the dumbbell supports. A 6in. pulley, attached to the foot lever, rotating 80 degrees is needed to turn a .5in. pulley approximately 2.6 times. Another 6in. pulley, attached to the dumbbell supports by cable, rotates in unison with the .5in. pulley to pull the dumbbell supports 40in. Due to the unique sizes of the pulleys they need to be ordered from a pulley manufacturer.

A tube running from the back bench supports, through the dumbbell supports base and into the front bench supports keeps the dumbbell supports moving in a straight line (DP4.1.3). This can be made of any available material as the forces on it are minimal.

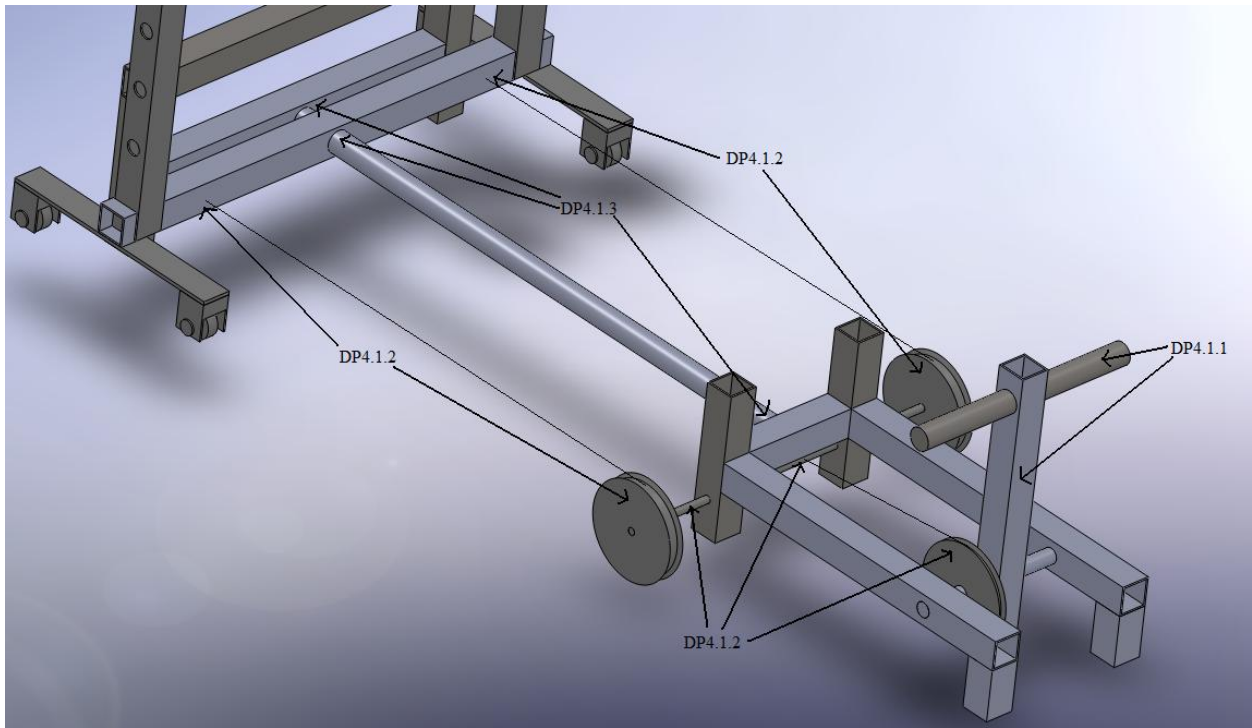

Figure 15 - DP4.1.1, 4.1.2 and 4.1.3

To adjust the dumbbell holders vertically rails of square tubing with an inner width equal to just larger than the outer width of the arms was used to guide them up and down (DP4.2). Due to the unique size of the rail, a steel plate should be cut into rectangular pieces with the dimensions needed to fit around the arm. These steel plate rectangles should then be welded together on the outside surface of the rail only to prevent friction when running along the arm. To hold the dumbbells in place holes were drilled through the rails and the arms and a steel pin is used to secure the dumbbell holders in place (DP4.3).

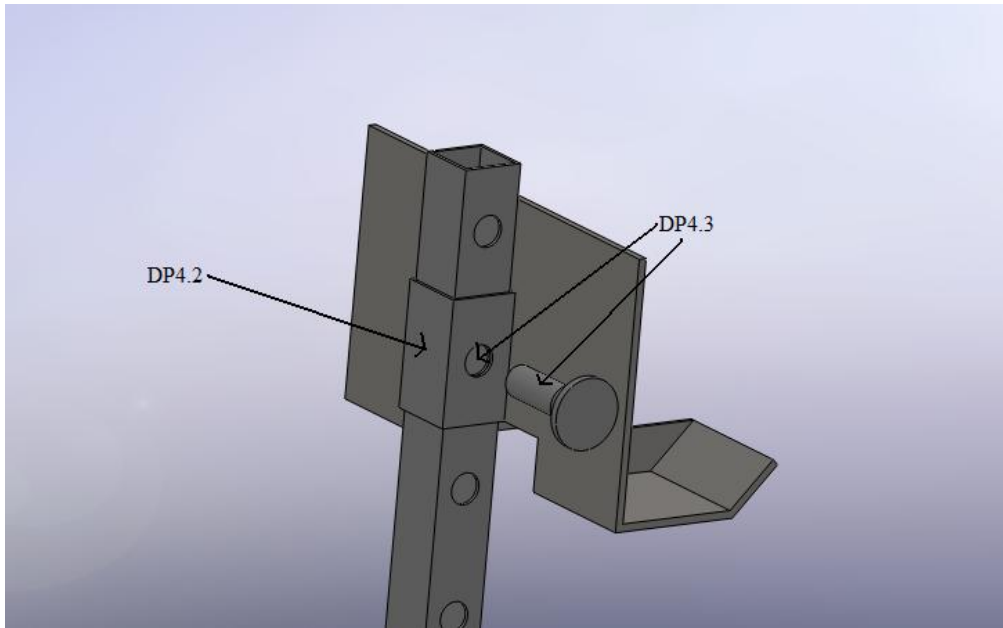

Figure 16 - DP4.2 and DP4.3

DP5 Provide System to Move Dumbbell Support from Exercise Area

A bungee cord is used to move the dumbbell supports from the exercise area (DP5.1). The bungee cord is attached to the back bench supports and to the back of the dumbbell supports base. A foam cushion is used to prevent the dumbbell supports from hitting the bench supports (DP5.2). This foam cushion is attached to the front of the back guide rail support.

DP6 Provide System to Assist User in Loading Dumbbells

To raise the position in which the user loads the dumbbells onto the dumbbell holders a step is attached to the back of the bench (DP6). The steel step is supported in back by two lengths of square tubing and in front by the back bench support.

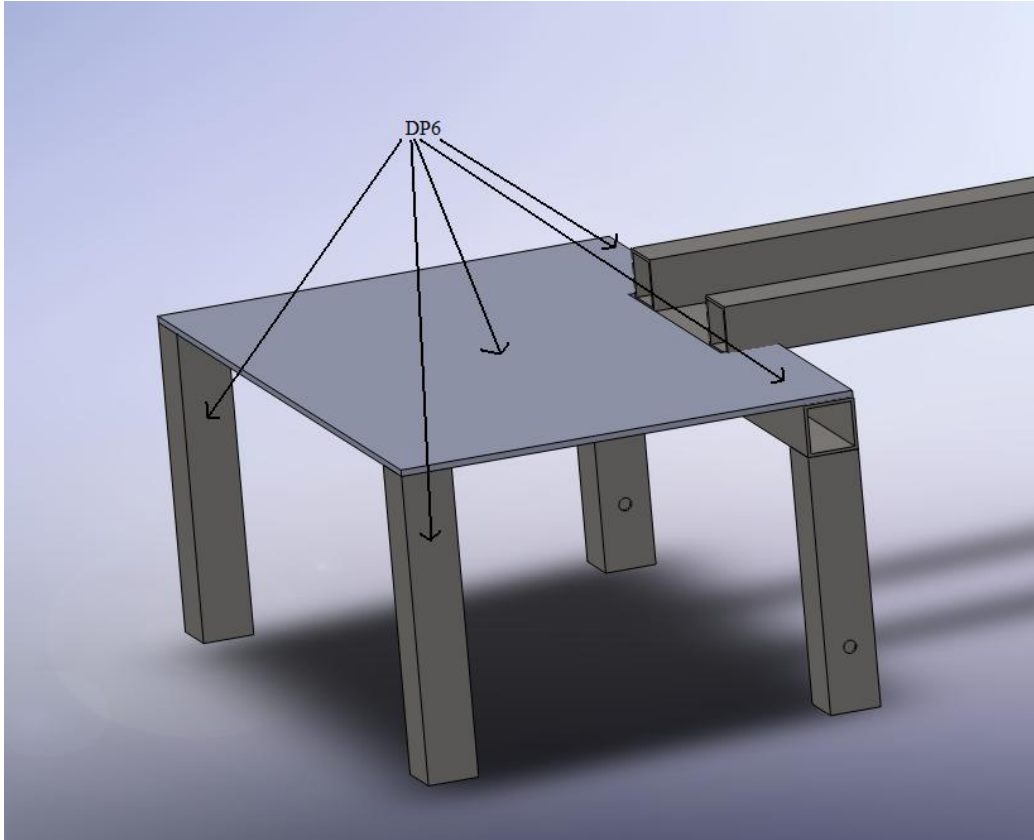

Figure 17 - DP6

Design Matrix

The design matrix is created to check for coupling between FR's and DP's. The matrix matches FR's to each DP with an influence over it. An "x" mark denotes the DP has an influence over the FR and a "o" denotes there is no influence. A DP with an 'x' mark in its column other than the intended FR designates a coupled design. Our design is coupled in the areas shown by the design matrix below. Our design is coupled in both areas where both support and adjustability is needed. The adjustments to these parts of our design are made along a structure also used for support. The three "x" marks in the bottom left are coupled because they rely on the vertical support structure for the user.

	DP0: Device for safely moving dumbbells	DP1: device for user stabilization	DP1.1: Pads to provide user rolling stabilization	DP1.1.1: pad to support lower half of user	DP1.1.2: structure to support lower pad	DP1.1.3: pad to support upper half of user	DP1.1.4: structure to support upper pad	DP1.2: device for user vertical support	DP1.2.1: device to vertically support lower	DP1.2.2: device for vertical support of upper	DP2: device to adjust user position	DP2.1: device to adjust user position on upper	DP2.2: device to adjust upper vertical support	DP3: device for holding dumbbells	DP3.1: rack for dumbbell support	DP3.2: arm for rack support	DP3.3: base for arm support	DP3.4: wheels to support base	DP4: device to adjust dumbbell supports	DP4.1: system to adjust dumbbell supports horizontally	DP4.2: rails to adjust dumbbell racks vertically	DP4.3: pins to lock rack to arm	DP5: device to move dumbbell supports from exercise area	DP5.1: mechanism to pull dumbbell supports back	DP5.2: device to stop dumbbell supports	DP6: step to assist user in loading dumbbells	
FR0: Provide a machine to move dumbbells safely	X																										
FR1: provide user stabilization	X																										
FR1.1: provide user rolling stabilization		X																									
FR1.1.1: provide support for lower half of user			X																								
FR1.1.2: provide lower pad stabilization				X																							
FR1.1.3: provide support for upper half of user					X																						
FR1.1.4: provide upper pad stabilization						X																					
FR1.2: provide user vertical support							X																				
FR1.2.1: provide vertical support for lower pad								X																			
FR1.2.2: provide vertical support for upper pad									X																		
FR2: provide system to adjust user position										X																	
FR2.1: provide system to adjust user position on upper vertical support bar											X																
FR2.2: provide system to adjust upper vertical support bar on base												X															
FR3: provide a device to securely hold dumbbells														X													
FR3.1: provide dumbbell support															X												
FR3.2: provide support for rack																X											
FR3.3: provide support for arm																	X										
FR3.4: provide support for base																		X									
FR4: provide system to adjust dumbbell supports																				X							
FR4.1: provide system to adjust dumbbell supports horizontally																					X						
FR4.2: provide system to adjust dumbbell racks vertically along arms																						X					
FR4.3: provide system to lock rack to arm																							X				
FR5: provide system to move dumbbell supports from exercise area																								X			
FR5.1: provide mechanism to pull dumbbell supports back																									X		
FR5.2: provide system to stop dumbbell supports																										X	
FR6: Provide system to assist user in loading dumbbells																											X

Figure 18 - Design Matrix

Prototype Production

The Prototype was ready for manufacturing after the design was completed in Solid Works. Steel was the material of choice due to its high strength and availability. Steel is the material choice of past and current benches on the market. Machined solid plastic (UHMW) pulleys along with rope were used to make the moving mechanism. Manual machining was used to build the prototype.

The horizontal band saw was used first in order to cut the steel to the specific design dimensions. It was important to use appropriate blade for steel with the appropriate speed. During this stage square tubing, rods, and flat steel were cut. Measuring tape was used to find dimensions and the steel pieces were pushed through the horizontal band saw by hand. Any burrs on the steel were removed.

The mill was used in order to drill the appropriate holes called for in the design. The bed of the mill contains a vice that was used to fixate the steel. Other fixating devices can be attached, but the vice was sufficient to make necessary holes. The mill is capable of moving in the X, Y, and Z directions via hand crank or automatic feed motors. Once the Z direction was set, only movement in the X-Y plane was necessary. Measuring tape was used to mark drilling locations. There was a digital read and display to further precision and guarantee accurate measurements for milling locations. The mill spindle was set to the appropriate speed by reading the predetermined speeds based by material that was provided on mill itself. The drill bit diameter was selected accordingly to create holes that match the design specifications. The mill was then turned on and drill bit lowered to perform its task. The mill was also used to drill an

imperative hole in each pulley, from the outside track to the center. This was done by executing the same steps described above. Any burrs leftover were removed.

Once all the appropriate cuts and holes were made in the steel. The MIG welder was used to construct the bench frame and other steel components. Welding was used to join the steel pieces by melting the pieces together along with copper filler to create a weld pool. The weld pool creates a strong joint between the steel pieces. The MIG welder had a chart that was used to set the appropriate feed rate and voltage for the welding based on the gas being used, material being welded, filler material, and filler thickness. The gas was a steel mix (25% CO₂ and 75% Ar.) and copper coated steel wire filler with a diameter of 0.035in. was used. The feed rate and voltage had to continuously be adjusted due to differing thickness of the steel. For a proper weld full penetration must be reached. If full penetration was not reached the voltage must be increased. If the voltage was too high holes would melt in the steel, so voltage must be lowered. As a general rule, if voltage is increased then the feed rate of the filler is decreased and vice versa.

The steel parts to be welded may be fixated by using C-clamps and/or magnets. Spot welds are first applied to insure proper junction of the steel parts. Spot welds are strong enough to temporarily hold the parts together for full penetration welds, so if a clamp is in the way it may be moved. Full penetration welds are then applied in a timely manner to allow some of the heat to dissipate. It is imperative not to hurrying the process. Not allowing the parts to properly cool can cause deformation and bending in the steel. Excess weld pools were grinded down, especially on pieces that need future welding.

The angular and bench grinder was used for removing burrs and excess weld from the steel. These tools were also to prepare the steel for welding. When welding, there must be a gap that the filler can pour into so that it may bond with the two conjoining pieces. If two pieces created a flat edge then this gap must be created. This is done by taking a piece of the steel and grinding the flat edges that are to be welded into a 45° angle. This is then done to the other piece of steel so that the gap looks like a greater than, “>”, sign. The angular and bench grinder were also used for fine tuning some of the part dimensions. If a piece of steel had to be shortened by a small distance then the grinders were often utilized. Some metal on metal moving parts also had to be grinded down to create more space that would allow the parts to move freely without being jammed or getting stuck. Before use of the angular grinder, the material must be fixated. This was accomplished by use of the bench vices.

The torch was used to heat up the steel in order to bend it straight. In order to obtain the proper shape for our back rest adjusting support we needed to cut two opposite walls from a length of steel square tubing. When these walls are cut from steel tubing the internal stresses are released deforming the steel. We used a torch to heat up the deformed pieces. This softened the steel us to bend the deformed walls back into the required shape.

Testing of the final design

The first evaluation was of the CAD drawing by use of COSMOSXpress. This is the Finite Element Analysis feature in Solidworks. To evaluate a part you would first select the material. Next you apply areas in which the part will be restrained. Then you apply a force to the required areas of the part. The COSMOSXpress program then generates data and gives diagrams of the part. These diagrams include the stress distribution, displacement distribution and deformed shape if applicable. Data is compiled and stresses are evaluated in order to determine any possible failures. Major areas of concern were pin locations and areas of high stress. Using Cosmos, it was determined that the design is likely to work. Figure 19 is an example of the displacement distribution of the back rest adjuster. As you can see the part will deform a few thousandths of an inch but will not break.

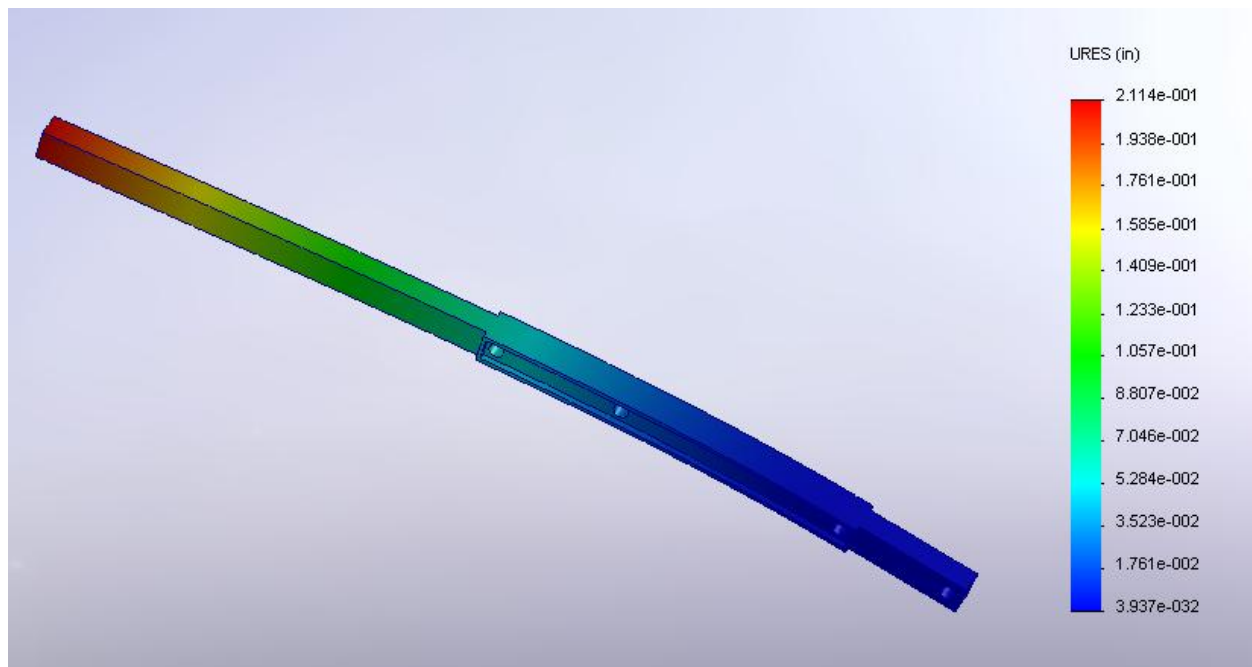

Figure 19 - COSMOSXpress of Back Rest Adjuster

EMG Testing

EMG analysis was conducted according to the “Standards for Reporting EMG Data,” (Merletti, et al., 1999). These standards can be found in Appendix #. This experiment was conducted in the Bioinstrumentation Teaching Lab in Salisbury 311 at Worcester Polytechnic Institute. Each pair of electrodes were attached to a BioPac Systems EMG 100 and set to 5000 gain. The data acquisition software used was AcqKnowledge 3.9.0 on a Dell SL311-03. Within the software, the six channels corresponding with a specific muscle were labeled “Deltoid”, “Forearm”, “Trap”, “Lower Back”, “Bicep”, and “Chest,” respectively. The acquisition sample rate was set to 200 samples per second and each experiment lasted for 30 seconds. The subjects for these tests were group members, Michael Toto and Andrew Sides.

Prior to testing, alcohol swabs were used to wipe down the areas where the electrodes would be placed. Pairs of aluminum surface electrodes (1” diameter) were placed on the subject at the deltoid, forearm, trapezius, lower back, bicep, and pectoralis major. Electrodes were specifically placed parallel to the muscle fibers on the innervations zone, or muscle belly, 1”-2” apart from each other. A ground electrode was attached to the subject’s right ankle.

Subjects were instructed to perform four total tests. Two tests would be from the incline (~45°) and two from the upright press positions (~85°) each. One of the two tests for each position will be conducted using the assistive dumbbell machine to place the dumbbells in the ready position, and the other will have the user lifting the dumbbells to the ready position on their own on a standard weight bench.

A pair of 30 lb dumbbells was used for each experiment. The thirty pound dumbbell weights were chosen because the subject could complete the required exercise with relative ease. It should be noted that the assistive dumbbell machine is designed universally for all users and that weights ranging from 0-200 pounds can be used, depending upon the user's muscular capabilities.

During the tests, the subject grabbed the weights, performed 4 fluent presses, and placed the weights back from where they were first picked up. The user would start at complete rest, conduct the exercise, and end at complete rest, with the EMG data would be measured for 30 seconds. EMG readings for the four tests were measured in Volts.

EMG Results

EMG testing reinforced our hypothesis that the current method to lift weights utilizes muscles not meant for these particular exercises. The incline press and shoulder press dumbbell exercises designed with the intention of working out the deltoid muscles, chest muscles, and trapezius muscle. The forearm, lower back, and bicep muscles are all used in these lifts, but only as secondary muscles for stabilization. The following figures 20-23 demonstrate the EMG readings collected from the Acquisition software. The muscles are labeled vertically on the left side of the figures and the amplitude of voltage on the right side. Figure 20 displays the subject completing four repetitions over a 30 second interval at 200 samples per second using the current method.

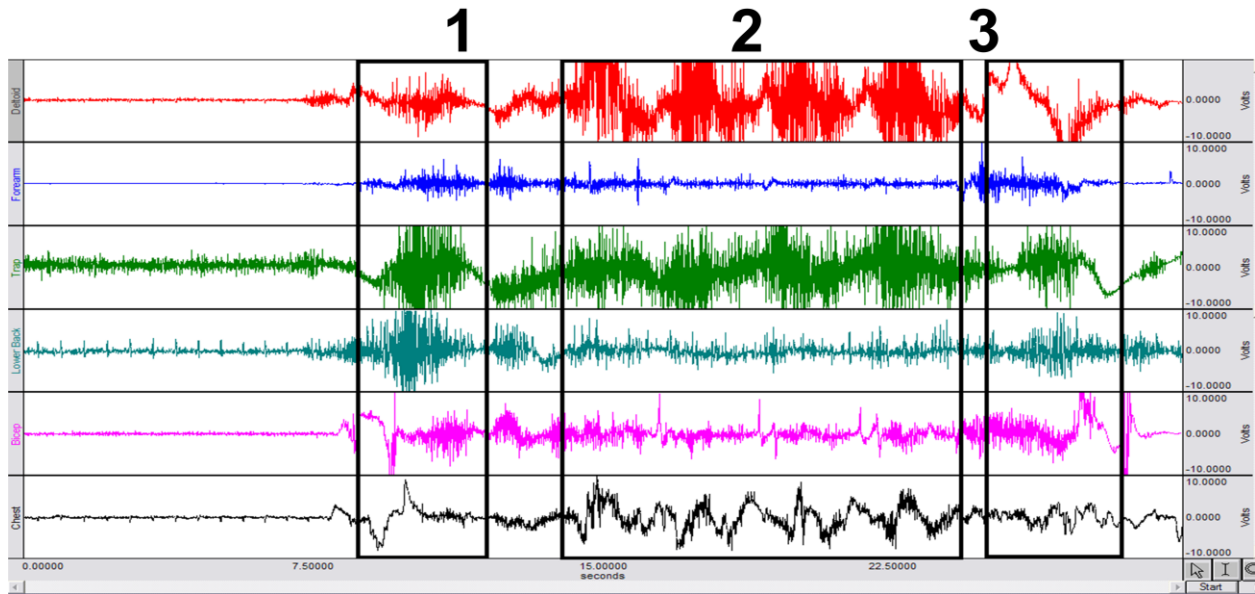

Figure 20 - Incline Press Using Current Method

The four repetitions the subject completes can be identified most clearly in the deltoid (red) EMG readings. There are four distinct peaks of voltage during the second phase of the readings which represent the muscle activity during the repetitions. The numbers above the EMG readings correspond to the phase of the exercise the subject was in. The first phase, represented by '1,' indicates the subject lifting the weights up from the ground and putting them into the ready position. For a visual of this process, reference Figure 4 in the rationale section. Phase 2, represented by '2,' indicates when the subject is performing the repetitions of the exercise, in this case four incline press repetitions.

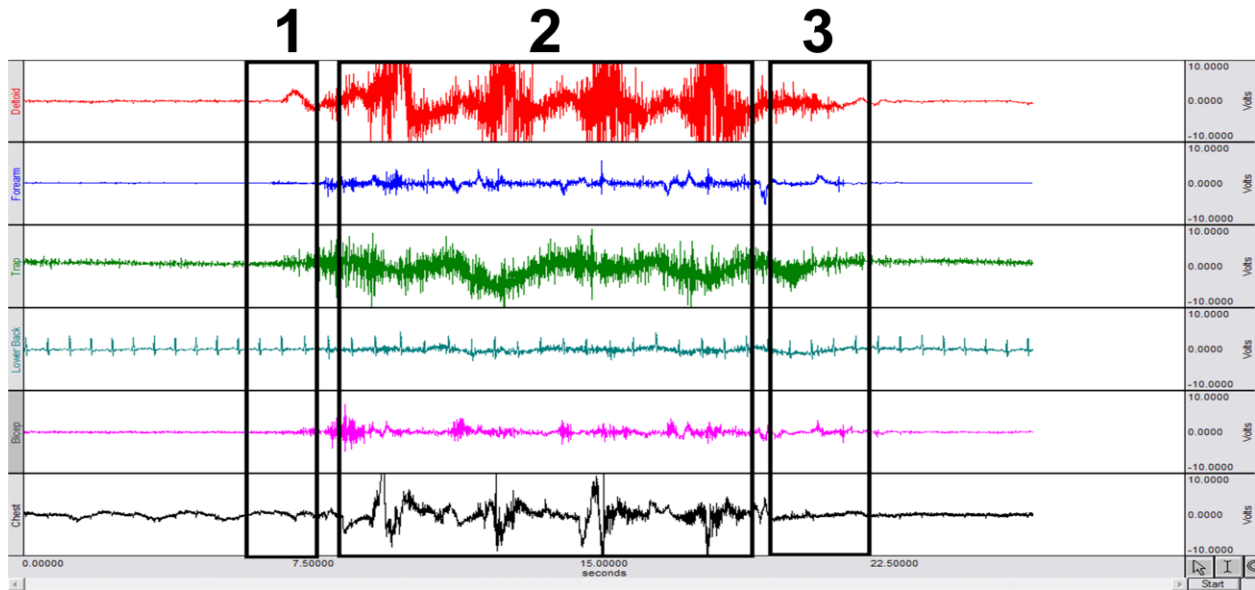

Figure 21 - Incline Press Using Assistive Machine

Phase 3, represented by ‘3,’ indicates when the subject has completed the four repetitions and places the weight back to where it was originally. In Figure 20, the subject has to pick the weights off the ground prior to performing the repetitions, conduct the exercise, and place the weights back on the ground. When the subject conducted the exercise using the Assistive Dumbbell Machine, as shown in Figure 21, they did not have to lift the weights to and from the ‘ready’ position in order to conduct and finish the exercise. The EMG results of the incline and shoulder press exercises using the current lifting method (Figures 20 and 22) reveal intense muscle activity during the pre and post phase of the lifts.

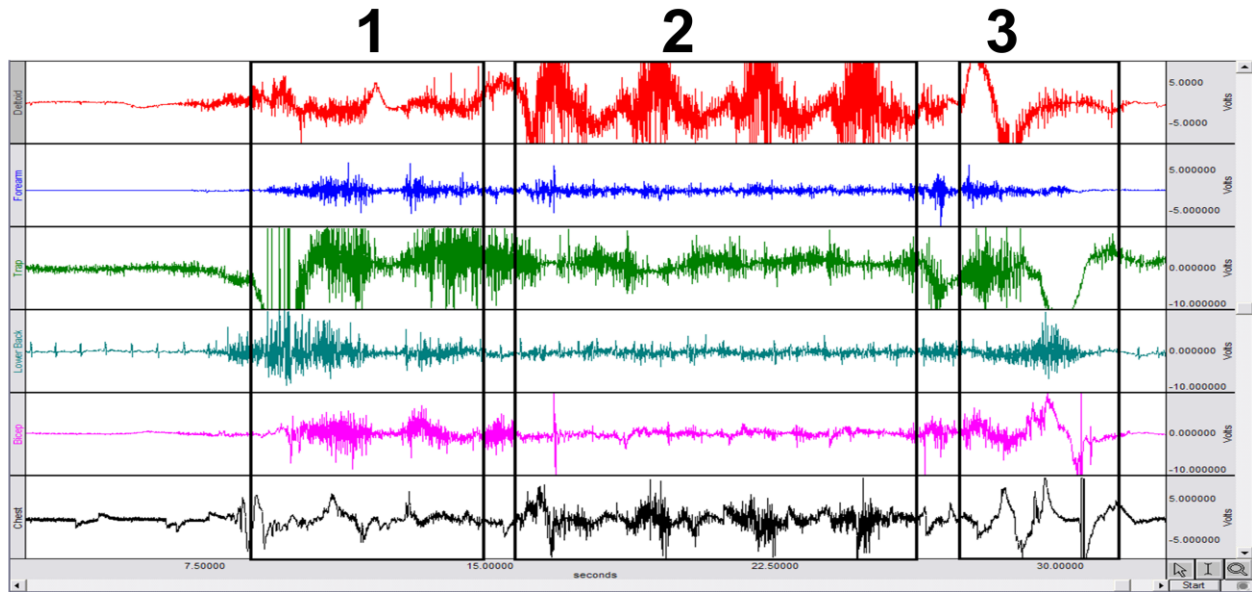

Figure 22 - Shoulder Press Using Current Method

In Figure 1 and 3 the muscles of the forearm, lower back, and bicep express some of the highest voltage readings throughout the 30 second time interval. Additionally, the deltoid, trapezius, and chest muscles are all exhibiting intense voltage readings during these two phase, sometimes displaying readings as high as those during the repetition phase of the test. Figures 2 and 4 display the EMG results for the incline press and shoulder press when using the Assistive Dumbbell Machine, respectively. When the user is conducting repetitions using the Assistive Dumbbell Machine, Phase 1 and 3 show little muscle activity during the start and finish of the shoulder press and incline press exercises.

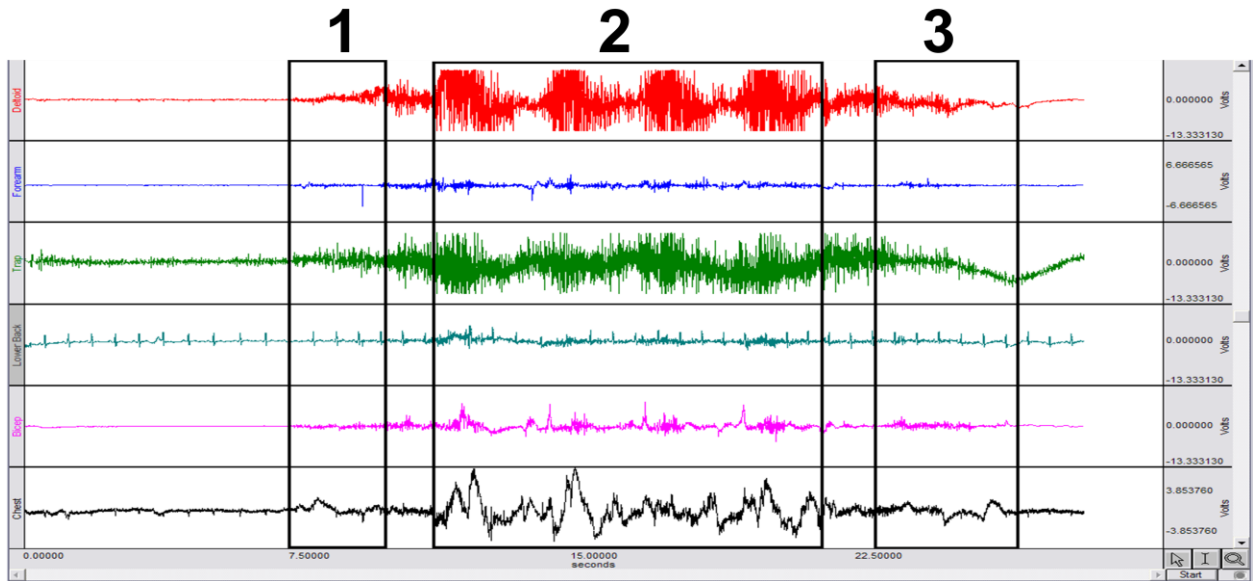

Figure 23 - Shoulder Press Using Assistive Machine

During these two phases there is only a slight increase in muscle activity attributed to the subject lifting the weights from the machine and stabilizing them prior to the repetitions. The second phase of the test reveals similar readings for all four of the exercises conducted (Figures 20-23), but the distinct difference is between the first and third phases of Figures 20 and 22 and Figures 21 and 23.

In addition to the difference in voltage amplitude between the current method and the Assistive Dumbbell Method, there is a noticeable difference in the time intervals of Phases 1 and 3. In Figures 20 and 22, the average time it takes the subject to get the weights into the ready position prior to the exercise and place the weights down following the exercise is 4.1 seconds, whereas in Figures 2 and 4, the average time for the subject is 2.9 seconds, a difference of 1.2 seconds. The same average time difference between the each pair of exercises for Phase 2 was only 0.2 seconds. The drastic difference in the first and third phase values could be attributed to the amount of force the subject was exerting getting the weight to and from the ready position.

Our observations from testing confirmed that the subject was straining during these phases and, as a result, these exercise phases took more time.

Design Discussion

The axiomatic design process was utilized in this project to allow the functional requirements (FR) of our product to drive the design parameters (DP). A unique DP was selected for each FR as an attempt at compliance with axiom. Two designs were investigated that satisfied the application needed for our final product. The designs that were assessed includes; a machine that included a pulley system with springs and rotating arms that provided the movement needed; and a pulley system with springs and a forward moving arm design that did not involve any rotation. Each design had complications along the way, which ultimately led us to decide which design would be a best fit for our first prototype. There were also components that would remain the same in the two designs. This includes the designs of the bench, and the dumbbell supports, which were also critically assessed to find the best solution. The design process and conclusion of each of these elements to the project will be explored in this section, as well as our assessment of our design process.

Bench Design

The key functional requirements of the bench are that it can satisfy all three exercise scenarios. Meaning that it can lay flat or 0 degrees for flat bench, 45 degrees for incline bench, and 90 degrees for military press. This promoted the question if purchasing a bench that already did these functions would be a better alternative then designing and manufacturing a new one. The three benches that were looked into are pictured in appendix 3. After looking into these three alternatives it was concluded that it would be best for our project, economically, and functionally, to design our own bench whose design was based off of these three products. The design that was taken into the manufacturing phase did not end up being the design of our final

prototype. The design of the back of the bench originally looked like the left portion of figure 24, but then because of weight and material constraints it was modified to the design in the right half.

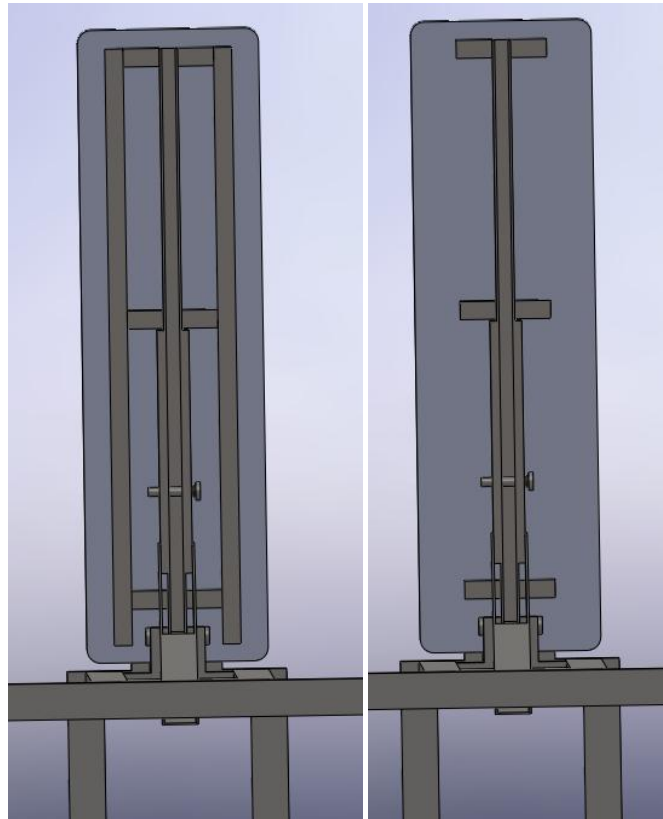

Figure 24 - Bench Pad Support Design

For future consideration it is suggested that aluminum is used for the moveable pieces behind the pad as seen in figures 24 as opposed to steel. It is also suggested to explore incorporating the position for decline bench as well, so the machine satisfies four exercises.

Dumbbell Support Design

The key functional requirements of the dumbbell supports are to support the dumbbells. The assessment of this includes material selection to support our design requirement of up to 200lbs, as well as being able to support a variety of different dumbbells.

It was necessary that the design of the support is compatible for a variety of dumbbells because there are many differently dumbbell designs on the market. Figures 39, 40 and 41 of appendix 4 give a sense of the variety of designs on the market. The final design was based off of measurement from the GPR Pro Style Rubber Dumbbell shown in figure 42. The design was assessed to be multifunctional for a variety of dumbbells but it proved itself unsuccessful, in the sense that the when using a variety of dumbbells they weren't flush in the supports. Figure 1 shows the un-flush nature of a type dumbbell in the support. The part plan for the support can be seen in appendix 5.



Figure 25 - Dumbbell Holders

The support is also required to sustain up to 200lbs. After finite element analysis provided by the CAM software in solid works it was determined that 1/4 " Plane Carbon Steel would more than provide the strength and satisfy the safety factor determined for this machine. Below is a

picture of the displacement of the support, although the deformation looks drastic in the image, the scale is so large that the displacements are in 1000ths of an inch.

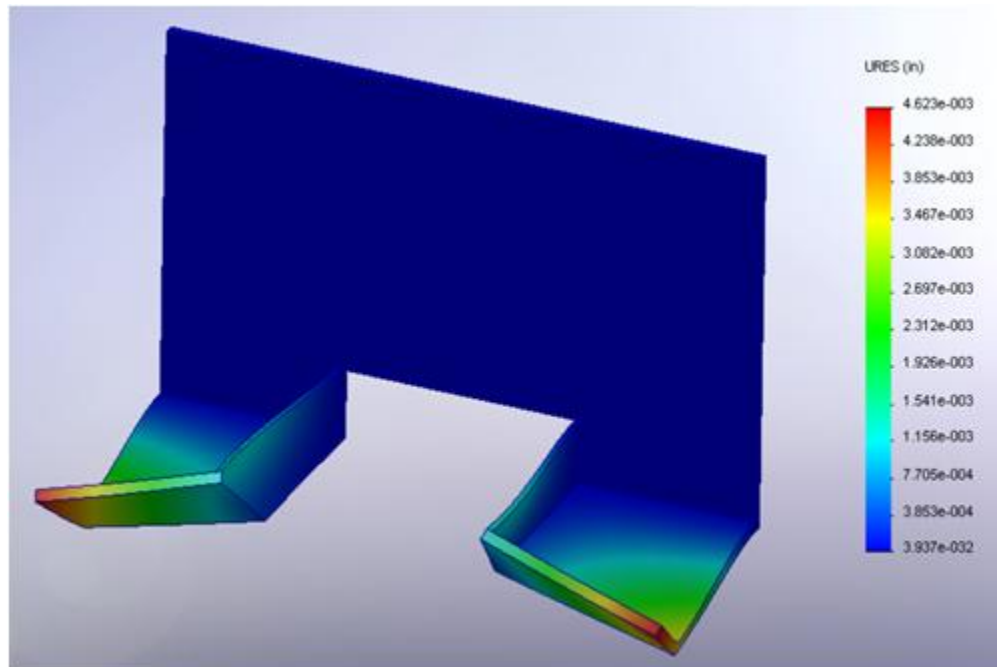

Figure 26 - Support FEA Image

For future consideration it is suggested that the design of the supports be reevaluated. The back of the support could have holes in it to lose some of the excess weight in the support. It is also suggested to look into using Bowflex Select Tech Dumbbells. These dumbbells are pictured and summarized in Appendix 4 and are dumbbells that can transform into whatever weight needed for the exercise. This would remove the step of loading the machine with dumbbells, and still be functional for the weights applicable by the Bowflex Select Tech Dumbbells.

Design 1, Pulley System with Rotational Arms

The basis of this design is to rotate the arms into the appropriate place to grab the weight, and then have them fall back behind the user of the machine so they can perform their exercise.

Figure 27 shows a solid model of the design. The design includes a pulley system that

incorporated two pulleys to the foot lever, which connected to the base of arms which were a rotating spool powered by a constant force spring. This would keep the tension in the pulley cables as the bench and arms moved for each exercise. Figure 27 shows where the arms would be located when the machine is stationary in the left portion, and the right portion shows where they would move to once the foot lever was pushed. The pulleys aren't incorporated in these images because of SolidWorks Constraints. The arms are also capable of moving to different locations pending on the position of the bench and which of the three exercises is being performed.

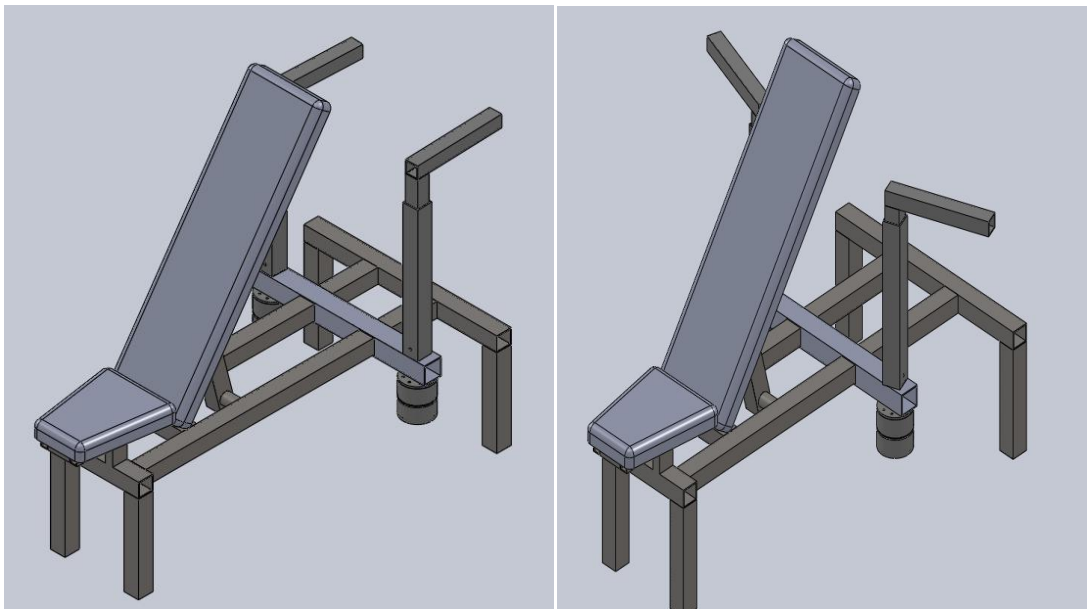

Figure 27 - Design 1

Figure 28 shows how the rotating spool keeps the tension in the wire. There is a constant force spring at the bottom of the spool that continually rotates the inner spool as the arms move positions along the bench. The figure shows the base of arm transparent so the spool can be seen as well as regular.

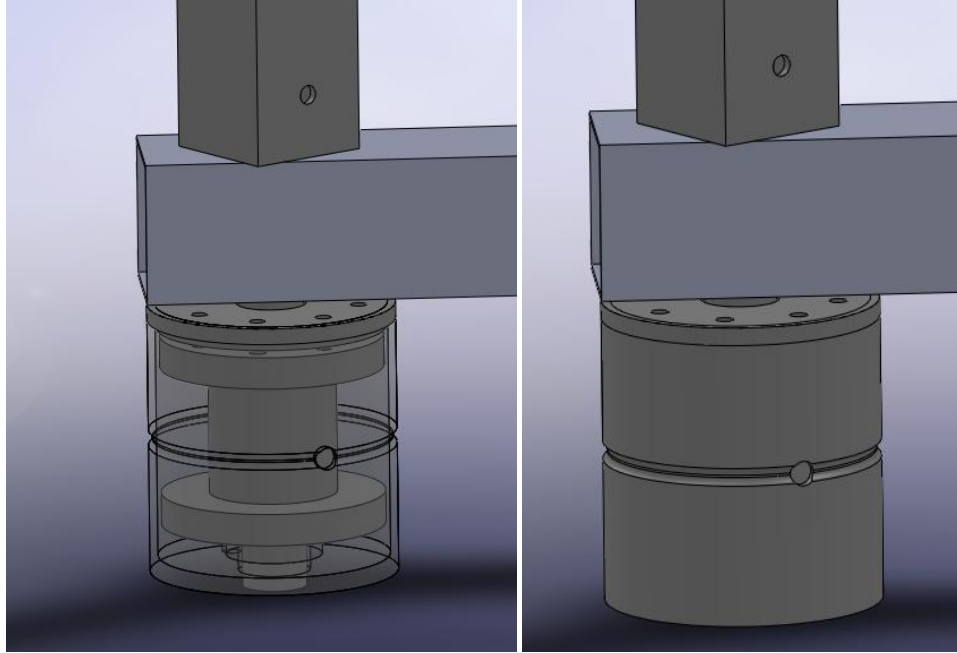

Figure 28 - Design 1 Arm Spool

The heights of the arms could be adjusted by a pin and adjusting an upper portion of the arm that fit inside a thicker portion. Our group realized that it would be crucial for the arm length to be adjustable so the machine can be sustainable for people of all sizes.

There were a few complications that came with this design. A specific complication involved the functionality of the arm spool. The cable wire wouldn't bend enough to get around a small spool, and a large spool would require a larger spring which wasn't cost affective.

If this design is pursued in the future, it is suggested that the arm design is based off of obtainable parts. Then design the sizing and materials of the less significant parts after.

Design 2, Pulley System with Forward Moving Arms

Design two is similar to design 1 in the sense that it incorporates a foot lever and pulley system. This design has the arms moving forward as opposed to rotating. Figure 29 shows the solid model of design 2 also not showing the pulley cables because of Solidwork constraints. The

machine incorporates gears to get the arms to move the full length for the three exercises offered by the bench. The user pushes the foot lever and pending on how far down the lever is pushed, that is how far the arms move. Figure 30 compares how the arms move once the foot lever is pushed down.

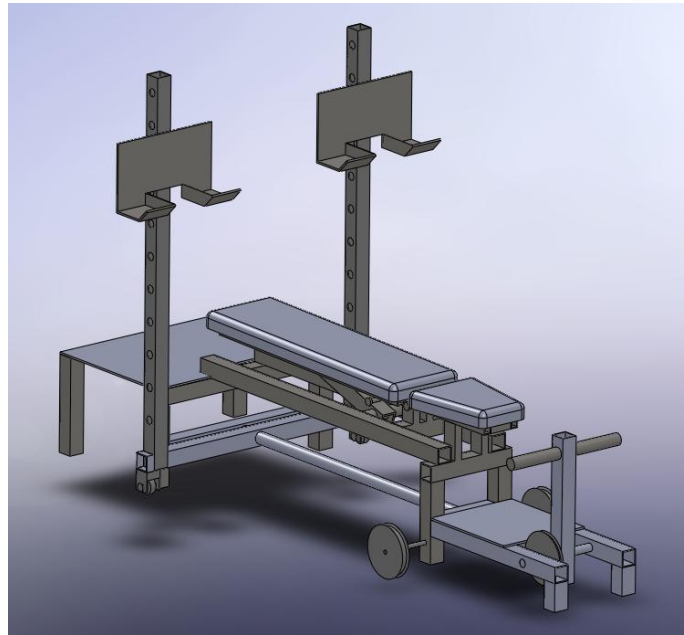

Figure 29 - Design 2

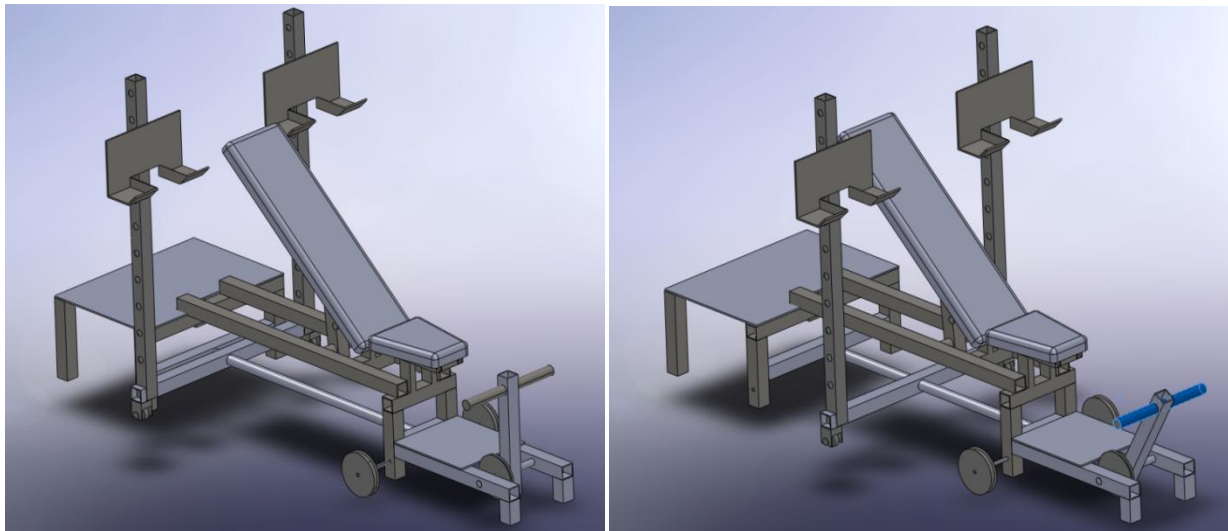

Figure 30 - Design 2 Functioning

The left half of the figure is the machine stationary and prepared for incline bench. The right side of the image shows how far the user would need to push the foot lever in order to get the arms in the appropriate position for the user to grab the dumbbells so they could perform their set. The arms would then fall back into the stationary position because of springs that attached the arms with wheels to the back base of the bench. The height of the arms in this design is changeable by a pin system.

When assessing the two final designs on which would be most suitable for the first prototype, the key focus were manufacturability and the price of the bench. When analyzing the two designs, it was concluded that design 1 was both more expensive and difficult to manufacture therefore the selection was design 2. Many changes were made in the process of manufacturing the original design because of financial and material restrictions.

There were also problems that arose during the manufacturing of the prototype that required immediate consideration and adjustments to the original design. One of the bigger problems was with the arms not being strong enough with only two wheels. Therefore another piece of steel was welded under both arms and four wheels used as oppose to two for more support.

Another problem that arose was that springs and steel pulley rope were the original plan to make the pulley system functional. The complication with the steel rope was that it would bend enough to be a part of our pulley system correctly. Therefore the solution was rope, which proved itself not as strong as the original steel rope that we had hoped would work. In terms of the springs we chose to use bungees instead, seeing that it was a prototype it was the easiest solution to make sure the prototype worked.

For future consideration, instead of rope, use a strong fishing line. Another thing to consider in future designs is the placement of the foot lever and the possibility of moving it a bit further up for accessibility and comfort to the user. It is also suggested that the width of the arms can be adjustable. The easibility of moving the device was also a complication once completely manufactured.

Gears Ratio

Basic geometry and engineering intuition was applied in the sizing of the gears. One mistake with the prototype was a result of the gears. The prototype was functional although the original gear design created torque two big in one of the movements therefore it was difficult to get the arms moving at all. When this problem was corrected the ratios were a bit off therefore the arms didn't move the full distance as implied.

Assessment of Design Method

As mentioned before the axiomatic design method was the approach taken in this project. There were many instances where our design process was very successful and then there were also places where we could have improved. The overall concept design of the project went real well. Some places that could have improved would be some of the little problems in the design that led to quick changes while manufacturing to meet the deadline. This includes the gear problem with little torque, as well as the base for the arms and using 4 wheels as opposed to two.

Concluding Remarks

This project was the development and reasoning behind the creation of a new dumbbell bench press for the gym. EMG testing proved that there is a need for this type of device in the gym.

The project successfully created a new prototype dumbbell bench press that is specifically for the three dumbbell exercises, flat, incline and vertical dumbbell bench press.

References

- V. Ammoscato, K.A. Dewolf. "Retractable dumbbell support bench" U.S. Patent 5 472 397, Dec. 5, 1995
- J. Clover, "Sports Medicine Essentials: Core Concepts in Athletic Training and Fitness Instruction", Cengage Learning, 2001.
- S. Delp, W.M. Murray, J. Uhlir, R.J. Triolo, "Architecture of the rectus abdominis, quadratus lumborum, and erector spinae", *J. of Biomech*, vol. 34, pp. 371-342, March 2001
- R.C. Hayden. "Dumbbell rack attachment for exercise weight bench column" U.S. Patent 5 411 459, May 2, 1995.
- R. G. Hummer, "Dumbbell Spotter" U.S. Patent 7 001 314, Nov. 7, 2001.
- D.M. Jordan, "Multilevel dumbbell support apparatus" U.S. Patent 6 149 556, Dec. 21, 2000.
- R. Newton, A. Murphy, B. Humphries, G. Wilson, W. Kraemer, K. Hakkinen, "Influence of load and stretch shortening cycle on the kinematics, kinetics and muscle activation that occurs during explosive upper-body movements," *Eur J Appl Physiol*, vol. 75, pp.333-342, July 1996.
- S. N. Robinovitch, "Biomechanics of Lifting and Lower Back Pain", Simon Fraser University School of Kinesiology, Canada 2008.
- M. Sarti, M. Monfort, M.A. Fuster, and L.A. Villaplana, "Muscle Activity in Upper and Lower Rectus Abdominus During Abdominal Exercises," *Arch Phys Med Rehabil*, vol. 77, December 1996.
- Nam Suh, *Axiomatic Design*, Oxford Press, New York 1990.
- M. Tulaszka, "Mechanical Properties of Striated Muscles", Poznan University of Medical Sciences, Poland 2008.
- A.J. Valentino, "Dumbbell suspension system" U.S. Patent 6 436 016, Sept. 18, 2000.

Appendix 1 – Online Forums

TOYOTA moving forward **\$185/MO PRIUS CLEARANCE!** **ENDS MAY 4TH** [CLICK HERE](#)

[John Stone Fitness Forums](#) > [Main Fitness Forums](#) > [Fitness Equipment](#) > Getting "into position" for dumbbell bench presses [PDA](#)

View Full Version : [Getting "into position" for dumbbell bench presses](#)

hardgeus Wed, April 12th, 2006, 03:17 PM
I do weight training at home with no spotter, which for most exercises hasn't been too much of a problem, but it has consistently kept me from pushing myself on the bench press. When I used a barbell, obviously, it was not desirable to pile too much weight onto the bar without a spotter or anyone around to get me from under the bar.
I recently switched to dumbbells, and have actually found that I get much better results than with the barbell. My chest is showing better definition than it ever has. I now want to move on to heavier dumbbells (to 60 lb from 50 lb) but I foresee a problem "getting into position".
I can easily bench press far heavier weight than I'm doing now, but I find getting into the bench press position difficult even with the weight I'm on now. What I currently do is pick up the dumbbells, sit on the bench, curl the dumbbells, and then lay back while moving the dumbbells into the bench press position. This puts a lot of strain on my lower back and abs, and I don't think it's a good idea to do it with more weight.
Is there a better way to get into position? If not, is there some sort of dumbbell mount that I could place behind my bench to hold the dumbbells for bench presses?

Blob Wed, April 12th, 2006, 03:28 PM
<http://exrx.net/AnimatedEx/PectoralSternal/DBBenchMount.gif>
Notice how you "kick" the weight back with your knees as you roll backwards.
There are various "spotter" devices for dumbbells, but I've never used them.

Enigma66 Wed, April 12th, 2006, 03:55 PM
<http://www.bodybuilding.com/store/cp/ph.html>

Skoorb Wed, April 12th, 2006, 06:32 PM
With some practice, you should be able to get to the point where you can competently move dumbbells into position that are far too heavy to have a meaningful set with. The technique I've always used is as the .gif shows. Sit in position, place the dumbbells on each knee, and kick them up, one at a time. The knee will kick it high enough to give it momentum that you can then finish by curling it up. Only with very light weights, if I'm feeling lazy/rushed, will I go from a standing position and drop, curling the weight up as I do it, so that the dumbbell is in the right position. That can be unsafe and cause tears and things but with the knee-kick technique you should be able to throw a bunch of weight up.

deleteall Thu, April 13th, 2006, 03:39 PM
Dumbbell trays
<http://newyorkbarbells.com/0310.html>

Gordo Thu, April 13th, 2006, 04:37 PM

THE GABRIEL METHOD
GabrielMethod.com
LOSE WEIGHT WITHOUT DIETING
"I was Losing Weight at a Rate of 5-7 lbs a Week"
Find Out MORE
"Wall Street Trader and Biochemical Researcher has "Wake-Up Call" After 9/11, Loses 220 lbs and Is Now Dedicating His Life To Helping Others Transform Their Bodies and Their Lives"
www.GabrielMethod.com/WeightLoss
Ads by Google

Figure 31 - John Stone Fitness Forum

TESTOSTERONE NATION The Intelligent and Relentless Pursuit of Muscle™

HOME T-NATION FORUMS FIGURE ATHLETE FORUMS TMUSCLE STORE LOGIN

BODYBUILDING

Positioning Heavy Dumbbells Rating 1 2 | Next Last FAV+

03-16-2009, 01:32 PM

sam_sneed
Level 0



Join date: Sep 2008
Location: New Jersey, USA
Posts: 207

Report Post

As the weight is going up I'm having trouble positioning the dumbbells on the flat bench. I tried doing 100lbs using my old method where I just have the dumbbells on the floor in front of me and I swing them up to my knees while I'm in the seated position. I then just lean back and start pressing and drop them from a low height when I'm done.

This is getting harder and I feel like I'm gonna throw my arm and shoulder out as I'm swinging them up to my knee. I can't imagine how you guys do this with 120's and up. Any pointers?

03-16-2009, 01:38 PM

Vegg
Level 0



Join date: Oct 2008

Place them on your knees and THEN sit down?

JOIN the NATION

Why Join T-Nation?

First Name E-Mail
Last Name Username
Sex: [v] [v] [v] [v]
DOB: [v] [v] [v] [v] [v] [v]

Sign Up!

By clicking Sign Up, you are indicating that you have read and agree to the [Terms of Use](#) and [Privacy Policy](#).

Already a member? [Log In!](#)

TMUSCLE STORE
100% Money-Back Guarantee!
FREE FedEx Shipping (USA)



Anabolic Food Additive
Learn more...

TMUSCLE™ MOST POPULAR PAGES

- Home Page
- Question of Strength: Vol 49
- Five Habits of Defective Squatters
- Training Archives
- Greg Valentino: The Most Hated Man in Bodybuilding
- Online Store
- TMagnum index
- Sex and the Male Animal
- Get a Life (Off Topic)
- Bodybuilding
- Question of Strength: Vol 49

Done Internet 100%

Figure 32 - Testosterone Nation Forum

Support StrongLifts.com
 Donate
 T-shirts
 Fitness Coaching

Recommended Products
 Starting Strength
 Burn The Fat
 Precision Nutrition
 Magnificent Mobility
 Inside/Out
 Strength Training Books

Non-Surgical Spinal Decompression is for Treatment of...

Click Here for a FREE Consultation

Lifting Heavy Dumbbells

14 posts • Page 1 of 1

POSTREPLY Search this topic... Search

Lifting Heavy Dumbbells
 by Doo on Wed Oct 01, 2008 1:09 pm

My current program has dumbbell work and I finally got a set of oly dumbbell handles so I can increase weight. I really like them. For some exercises I can use 70lb dumbbells and, without making the dumbbells too bulky, can add 8-10lb plates (I have about 20 total) to each dumbbell which, including bar weight, makes 90lb dumbbells.

The problem I have is safely getting those dumbbells off/on the floor when doing bench work. I work alone in my home gym. I do have padding where I could do a slight drop but I want to take care of my equipment and the padding isn't really all that thick.

Any suggested techniques?

Re: Lifting Heavy Dumbbells
 by Cleave on Wed Oct 01, 2008 2:19 pm

Increase your grip strength. Do Farmer Walks. All you do is grab two dumbbells and walk across the room and back. Do as high a weight as you can without dropping the weight.

Re: Lifting Heavy Dumbbells
 by Doo on Wed Oct 01, 2008 3:14 pm

Grip strength isn't the problem. I should explain a little better. I probably should have made the title of the topic "Lifting Heavy Dumbbells While Doing Bench Work".

I can somewhat easily do 70lb dumbbell bench press. I pick the dumbbells up from the floor while sitting on the bench and then swing them up. The main problem is after finishing the set. At that point, it is hard to sit back up and then set dumbbells down instead I try to let them down gently to the sides while I am still laying down. This puts my arms in an awkward position that seems like I am risking injury.

Re: Lifting Heavy Dumbbells
 by CoySpokes on Wed Oct 01, 2008 4:20 pm

Doo,

I think the beauty of using DB's is the fact that it is safer training to your max without a spotter knowing you can just dump the weight if you fail.

Ultimately, you may have to get your hands on some more foam or rubber mats? I dont imagine it possible to bring the DB's safely down to your hndr

Us av.
 Doo
 Posts: 977
 Joined: Tue Jan 15, 2008 7:08 pm

Cleave
 Moderator
 Posts: 405
 Joined: Tue Jun 03, 2008 5:06 pm
 Location: Tennessee

Us av.
 Doo
 Posts: 977
 Joined: Tue Jan 15, 2008 7:08 pm

CoySpokes
 Posts: 64
 Joined: Fri Sep 12, 2008 11:07 am

Done Internet 100%

Figure 33 - stronglift.com Forum

Appendix 2 – U.S. Patents

U.S. Patent 5411459- Dumbbell Rack Attachment

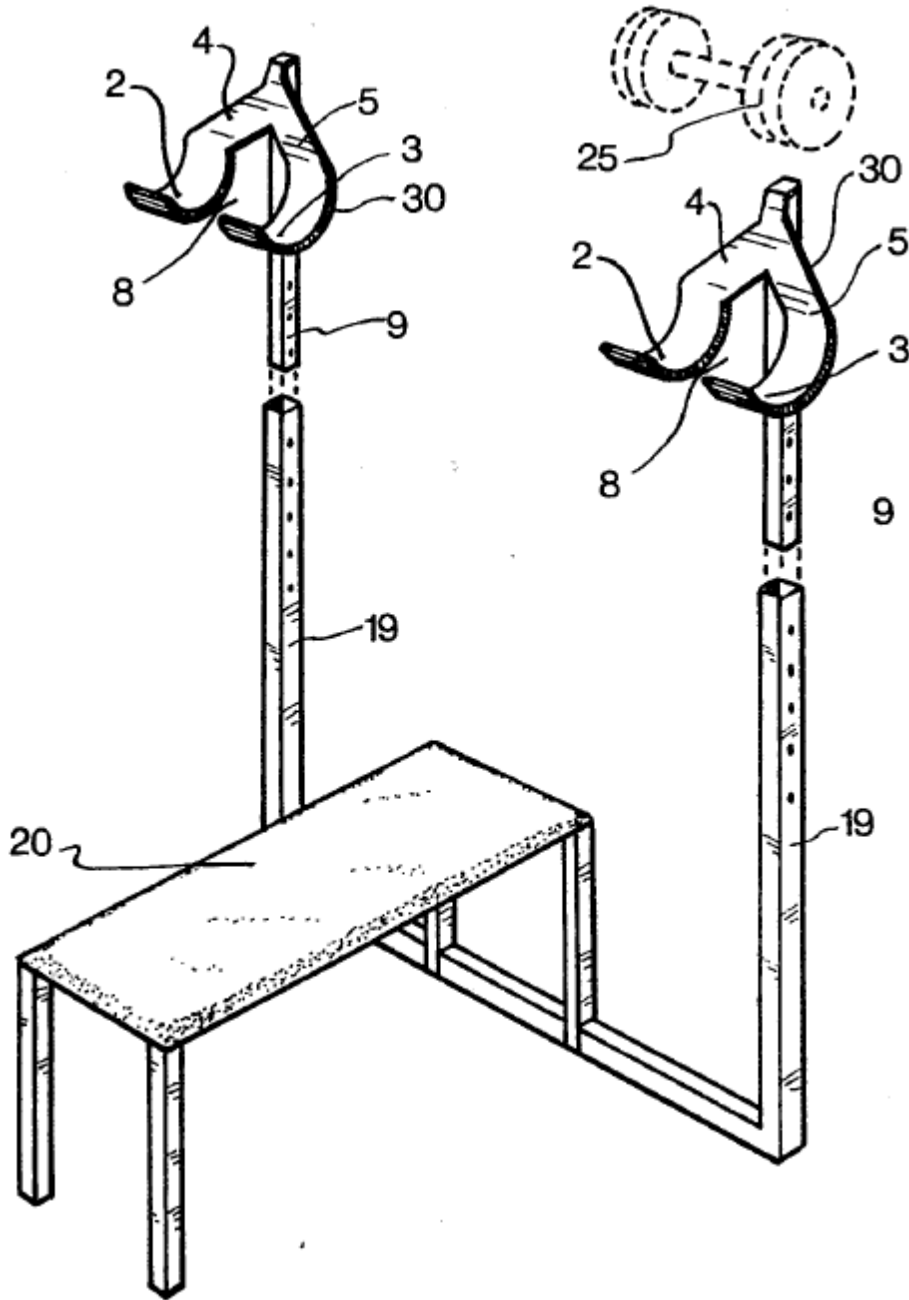

Figure 34 - US Patent 5411459 Dumbbell Rack Attachment

U.S. Patent 5472397- Retractable Dumbbell Support Bench

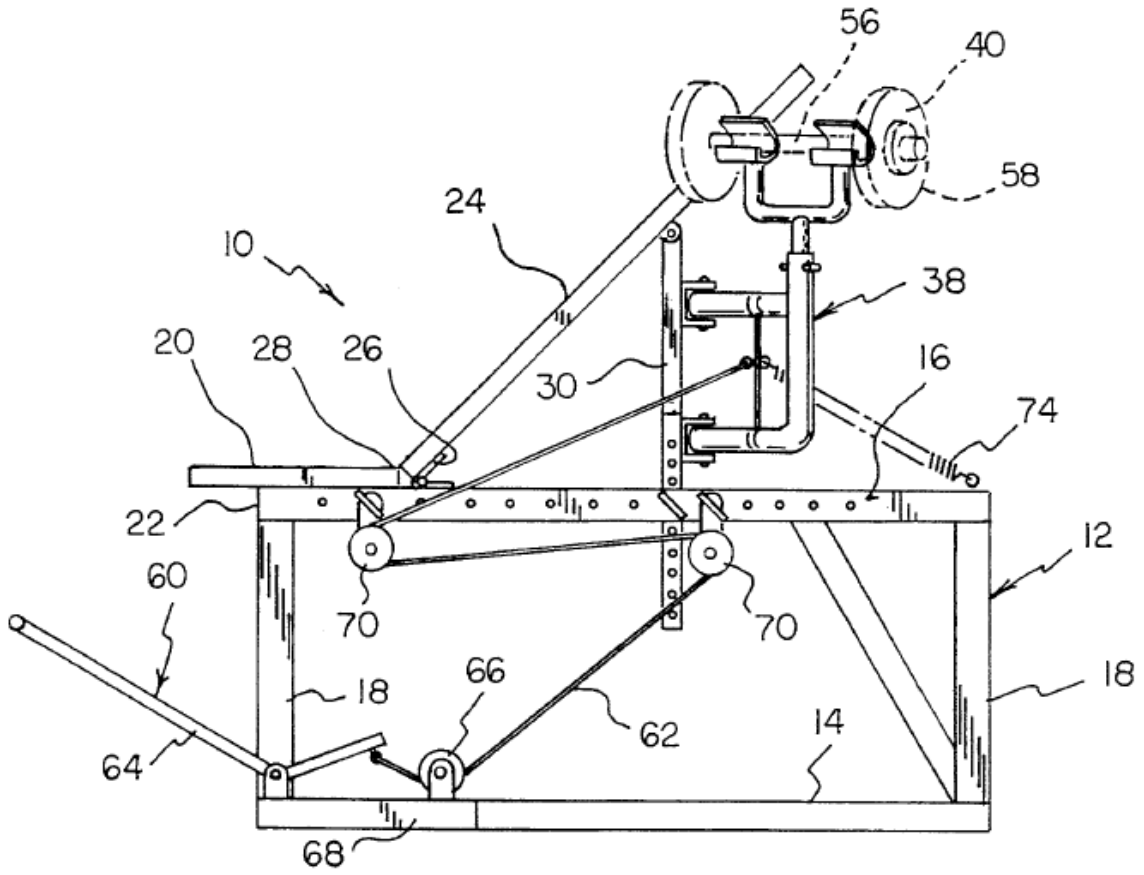

Figure 35 - US Patent 5472397 Retractable Dumbbell Support Bench

U.S. Patent 7001314- Dumbbell Spotter

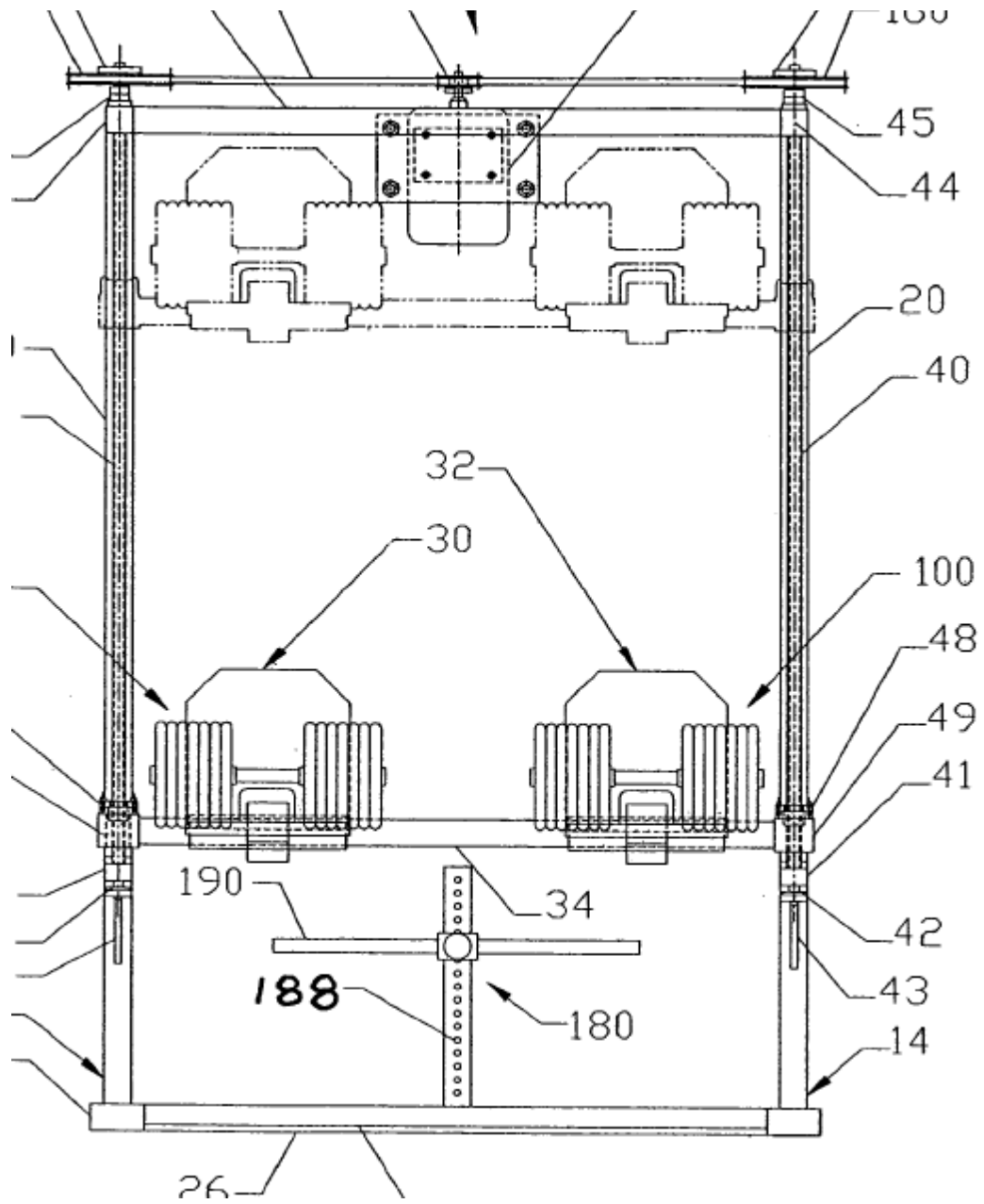

Figure 37 - US Patent 7001314 Dumbbell Spotter

U.S. Patent 6436016- Dumbbell Suspension System

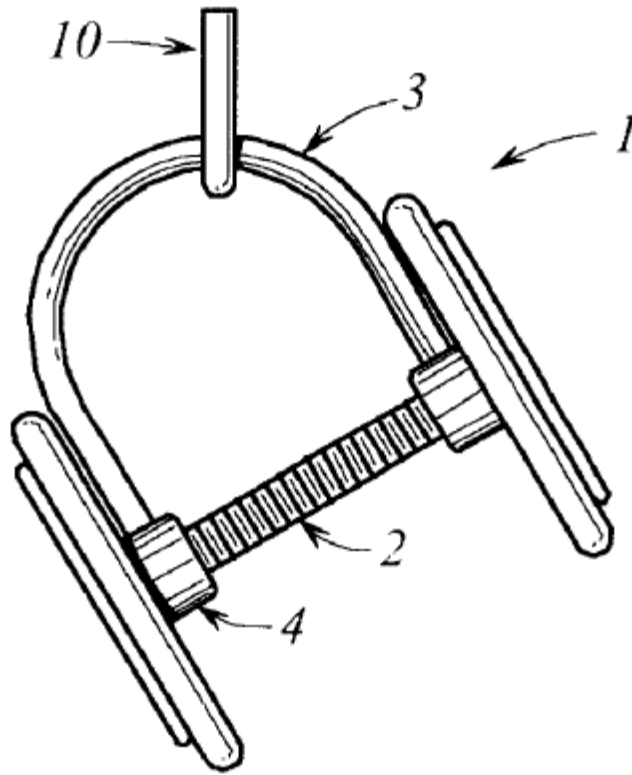

Figure 38 - US Patent 6436016 Dumbbell Suspension System

Appendix 3 – Variety of Benches



Figure 39 - Commercial 0-90 Degree Bench

http://www.yukon-fitness.com/Merchant2/merchant.mvc?Screen=PROD&Product_Code=COM-090&Category_Code=FW&Store_Code=yukon



Figure 40 - York Barbell Bench

http://www.g2fitnessproducts.com/ProductImages/york_barbell/st_series/54004_1.png



Figure 41 - RockSolid Fitness Bench

<http://store.rocksolidfitness.com/product.php?xProd=518&xSec=6>

Appendix 4 – Variety of Dumbbells



Figure 42 - GPR Pro Style Rubber Dumbbell

<http://www.csmfitness.com/PopUp/GPIProStyleRubberDumbbell.html>



Figure 43 - Cap Barbell Dumbbell

<http://www.dickssportinggoods.com/product/index.jsp?productId=841722>

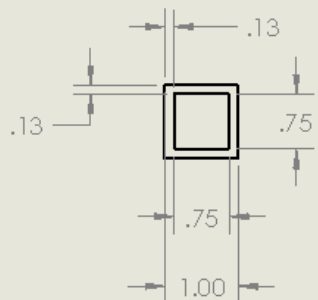

Figure 44 - Bowflex Select Tech 1090 Dumbbells

http://www.bowflexselecttech.com/bst_microsite/products/1090dumbbells/prdcdovr~710000/Bowflex+SelectTech+1090+Dumbbells.jsp

The Bowflex Select Tech Dumbbells are weight adjustable dumbbells that can range from 5lbs to 90 lbs by just clicking each dumbbell easily into position. The weight of the dumbbell is changed by a dial that rotates as seen in the image above.

Appendix 5 – Part Plans



FRONT VIEW (1/2 SCALE)

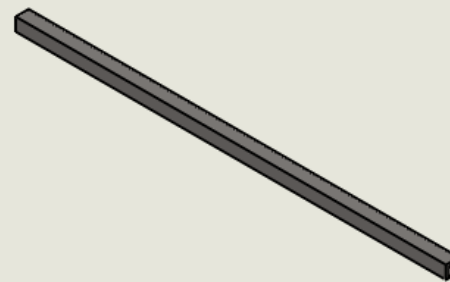

ISOMETRIC VIEW

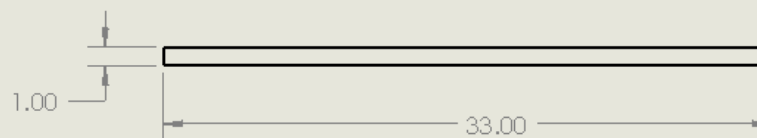

RIGHT SIDE VIEW



Worcester Polytechnic Intsitute

All dimensions are
inches and degrees

Pad Support

Default Tolerances

Part Number (1 of 31)

.1	(+)(-) .050
.12	(+)(-) .020
.123	(+)(-) .005
Angle	(+)(-) 1

Drawn by: Dumbell MGP Group

Quantity of Parts - 3

Scale:1:8

Date:4/29/2009

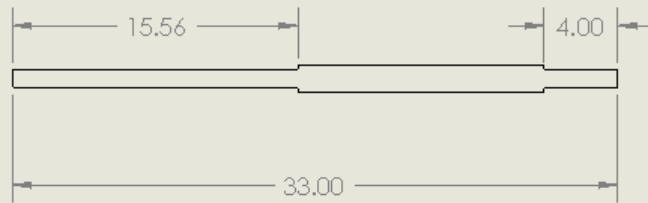

TOP VIEW

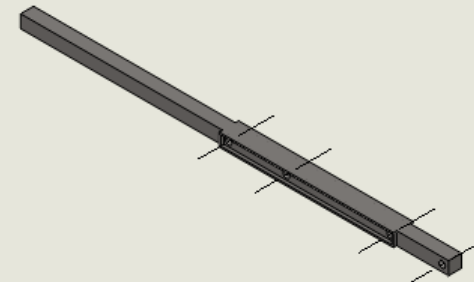

ISOMETRIC VIEW

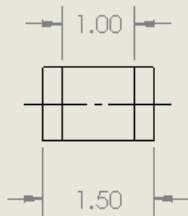

LEFT VIEW (SCALE 1 : 2)

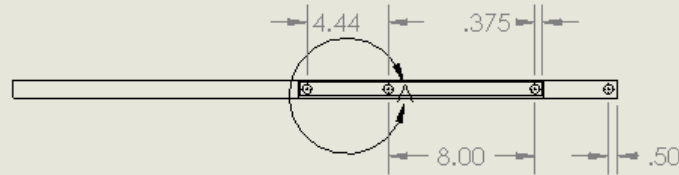

FRONT VIEW

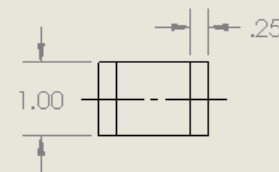

RIGHT VIEW (SCALE 1 : 2)

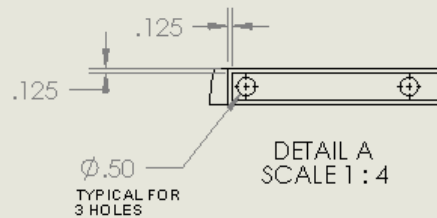

Worcester Polytechnic Institute

All dimensions are
inches and degrees

Pad Adjust

Default Tolerances

.1	(+)(-) .050
.12	(+)(-) .020
.123	(+)(-) .005
Angle	(+)(-) 1

Drawn by: Dumbell MQP Group

Part Number (2 of 31)

Quantity of Part - 1

Scale:1:8

Date:4/29/2009

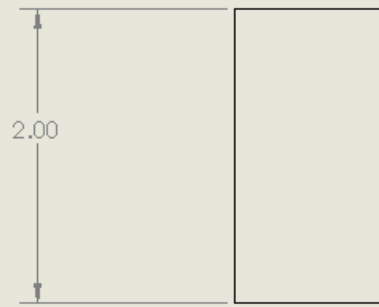

TOP VIEW

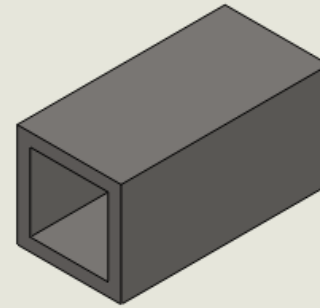

ISOMETRIC VIEW

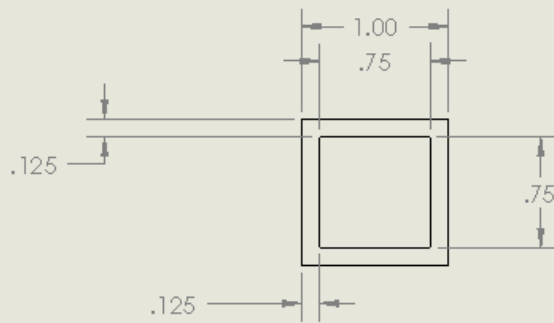

FRONT VIEW



SIDE VIEW



Worcester Polytechnic Intsitude

All dimensions are inches and degrees

Pad Cross Support

Default Tolerances

.1 (+X) -.050
 .12 (+X) -.020
 .123 (+X) -.005
 Angle (+X) 1

Drawn by: Dumbell MQP Group

Part Number(3of 31)

Quantity of Part - 6

Scale:1:1

Date:4/29/2009

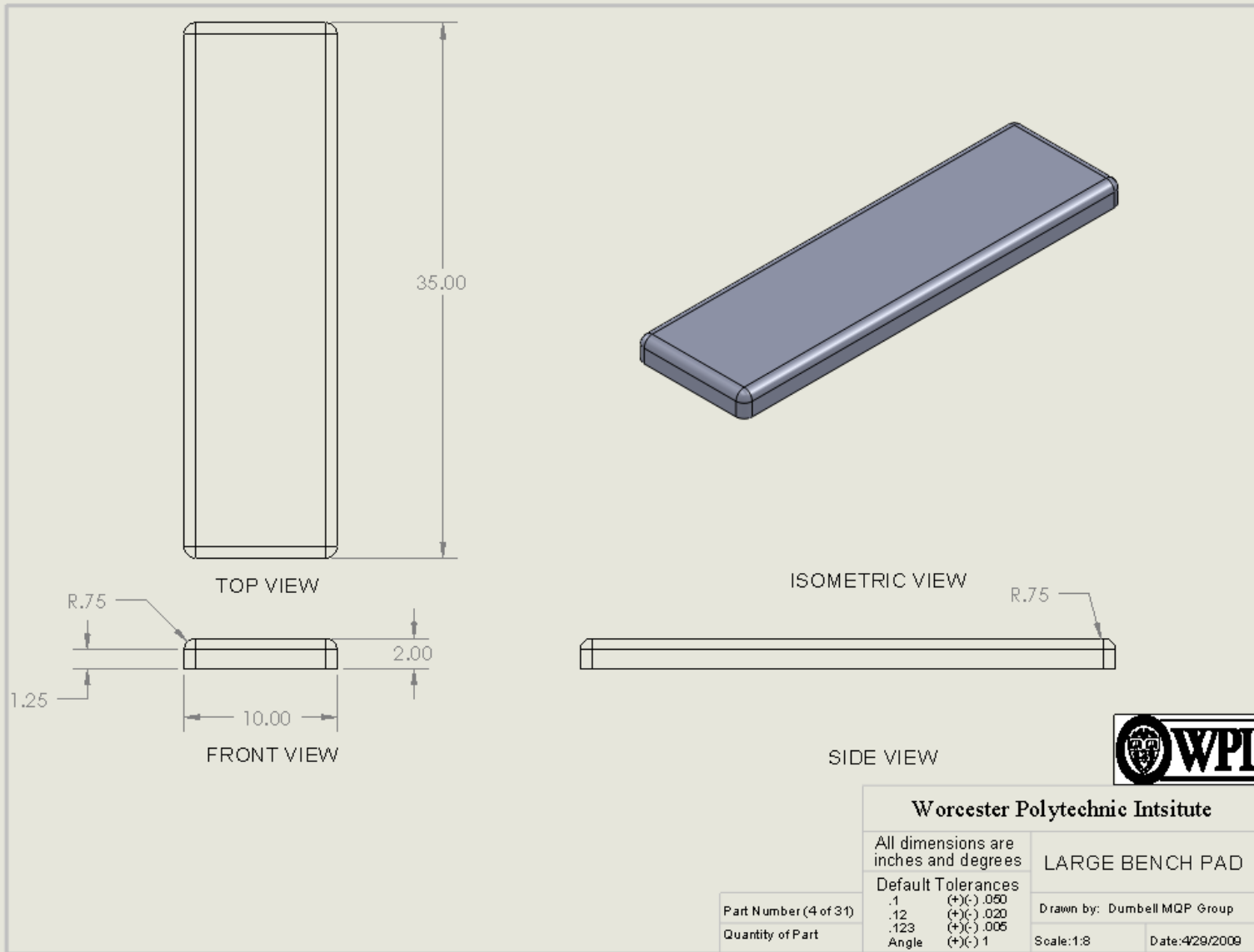

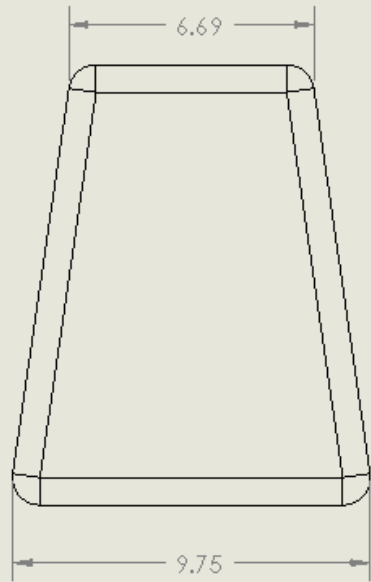

TOP VIEW

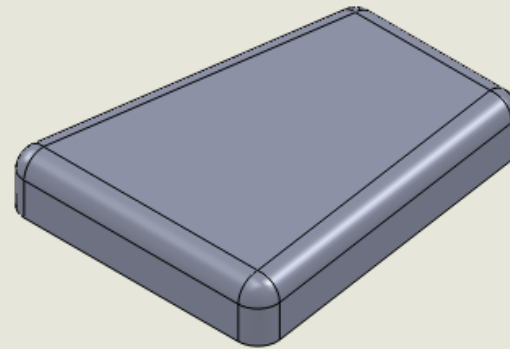

ISOMETRIC VIEW

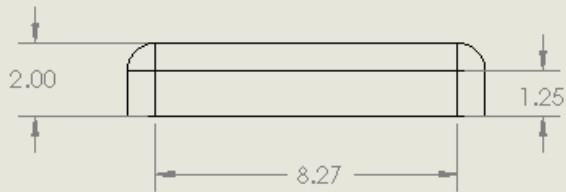

FRONT VIEW

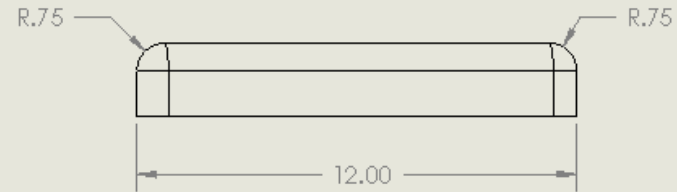

SIDE VIEW



Worcester Polytechnic Intsitute

All dimensions are inches and degrees

Small Bench Pad

Default Tolerances

.1	(+X) .050
.12	(+X) .020
.123	(+X) .005
Angle	(+X) 1

Drawn by: Dumbell MQP Group

Part Number (5 of 31)

Quantity of Part - 1

Scale:1:4

Date:4/29/2009



TOP VIEW

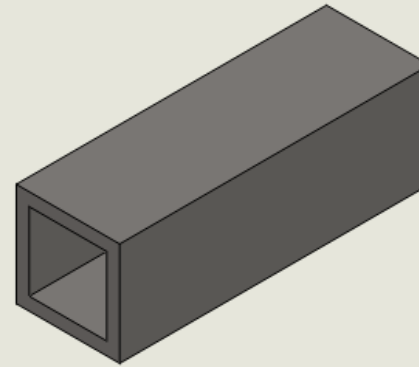

ISOMETRIC VIEW

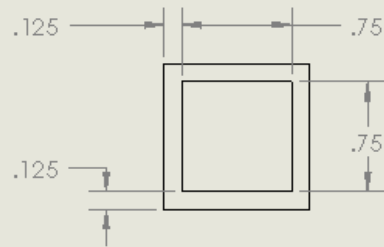

FRONT VIEW

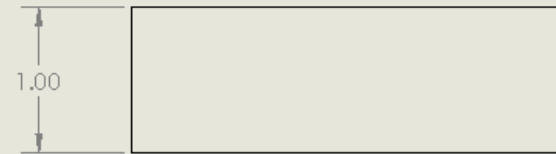

SIDE VIEW



Worcester Polytechnic Institute

All dimensions are
inches and degrees

Small Pad Cross
Support

Default Tolerances

Drawn by: Dumbell MQP Group

Part Number (6 of 31)

.1	(+)(-) .050
.12	(+)(-) .020
.123	(+)(-) .005
Angle	(+)(-) 1

Scale: 1:1

Date: 4/29/2009

Quantity of Part - 2

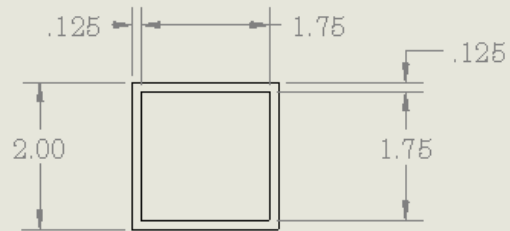

TOP VIEW (SCALE 1 : 2)

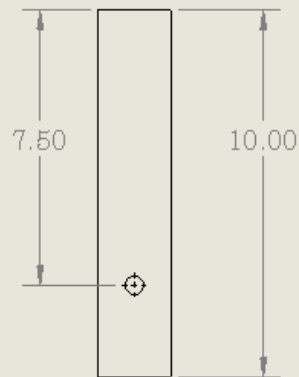

FRONT VIEW



ISOMETRIC VIEW

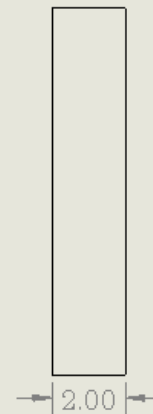

RIGHT SIDE VIEW



Worcester Polytechnic Institute

All dimensions are inches and degrees

LEG 3-26

Default Tolerances

Part Number (7 of 31)

.1	(+)(-) .050
.12	(+)(-) .020
.123	(+)(-) .005
Angle	(+)(-) 1

Drawn by: Dumbell MQP Group

Quantity of Part - 4

Scale:1:4

Date:4/29/2009

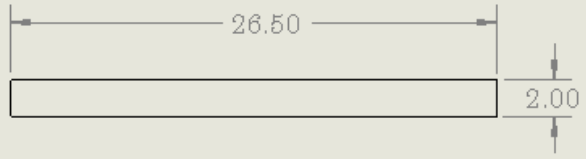
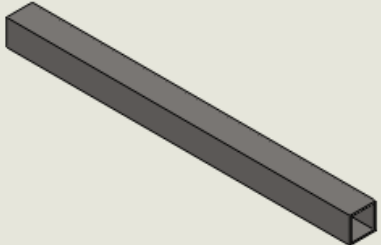

FRONT VIEW

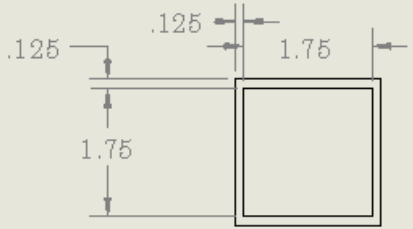

RIGHT SIDE VIEW (SCALE 1 : 2)



Worcester Polytechnic Intsitude

All dimensions are inches and degrees

LEG CONNECTOR

Default Tolerances

Drawn by: Dumbell MQP Group

Part Number (8 of 31)

.1	(+X) .050
.12	(+X) .020
.123	(+X) .005
Angle	(+X) 1

Quantity of Part - 1

Scale:1:8

Date:4/29/2009

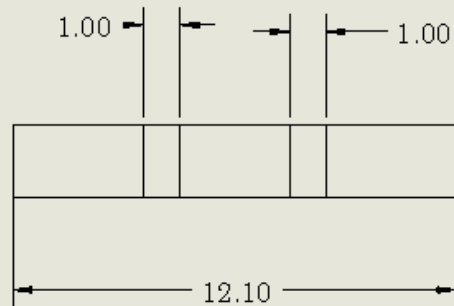

TOP VIEW

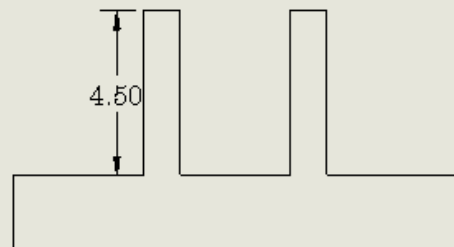

FRONT VIEW

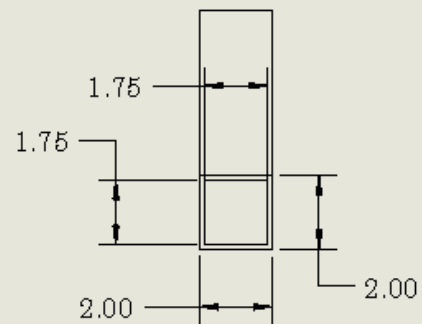
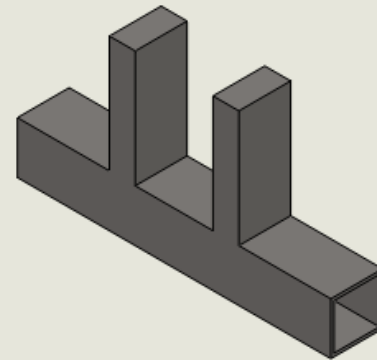

RIGHT VIEW



Worcester Polytechnic Institute

All dimensions are
inches and degrees

SUPPORT CONNECTOR

Default Tolerances

Part Number (P of 31)

.1	(+X) .050
.12	(+X) .020
.123	(+X) .005
Angle	(+X) 1

Drawn by: Dumbell MQP Group

Quantity - 1

Scale: 1:4

Date: 4/29/2009

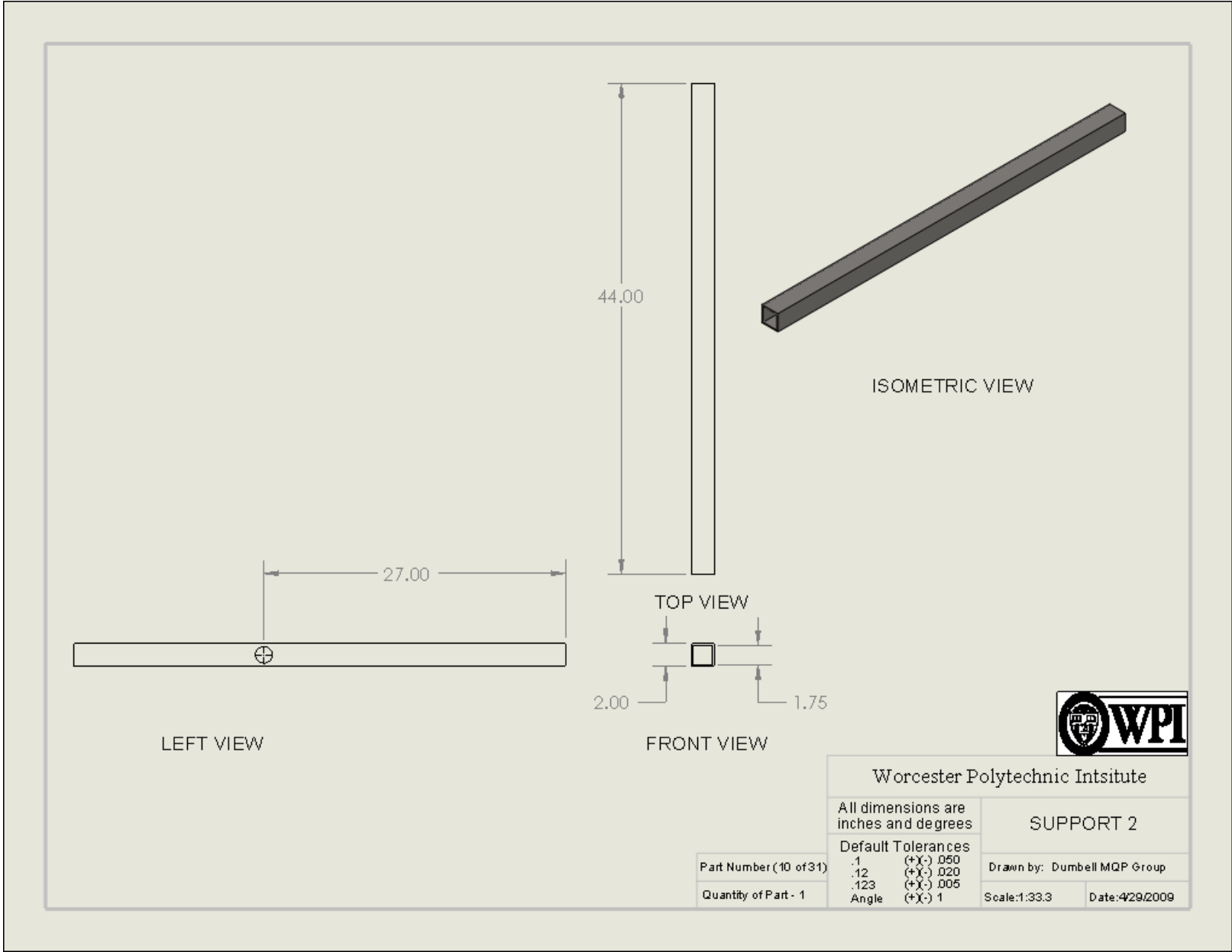

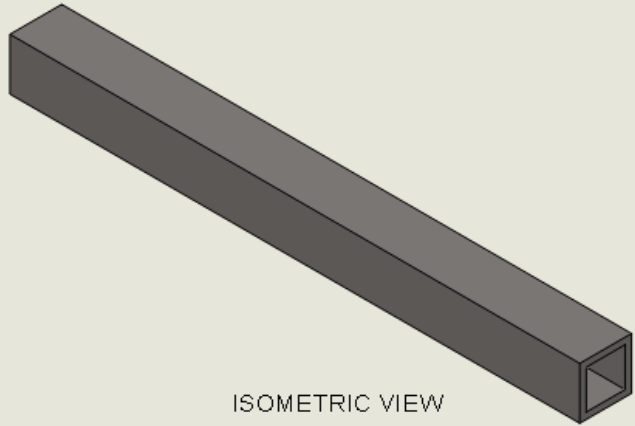

ISOMETRIC VIEW

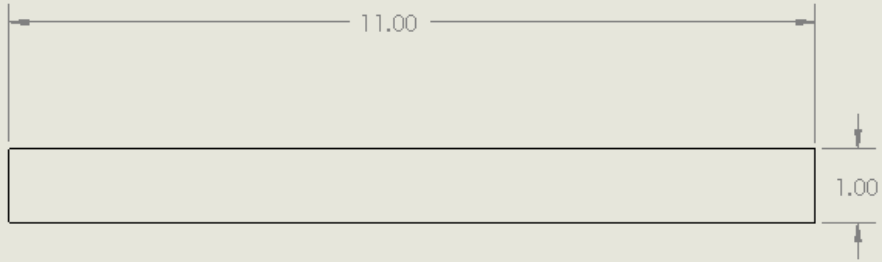

FRONT VIEW

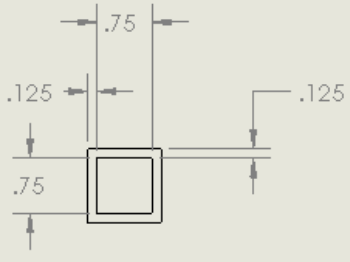

RIGHT SIDE VIEW



Worcester Polytechnic Institute

All dimensions are inches and degrees

SMALL PAD SUPPORT

Default Tolerances

.1	(+)(-) .050
.12	(+)(-) .020
.123	(+)(-) .005
Angle	(+)(-) 1

Drawn by: Dumbell MQP Group

Scale:1:2 Date:4/29/2009

Part Number (11 of 31)

Quantity of Part- 2

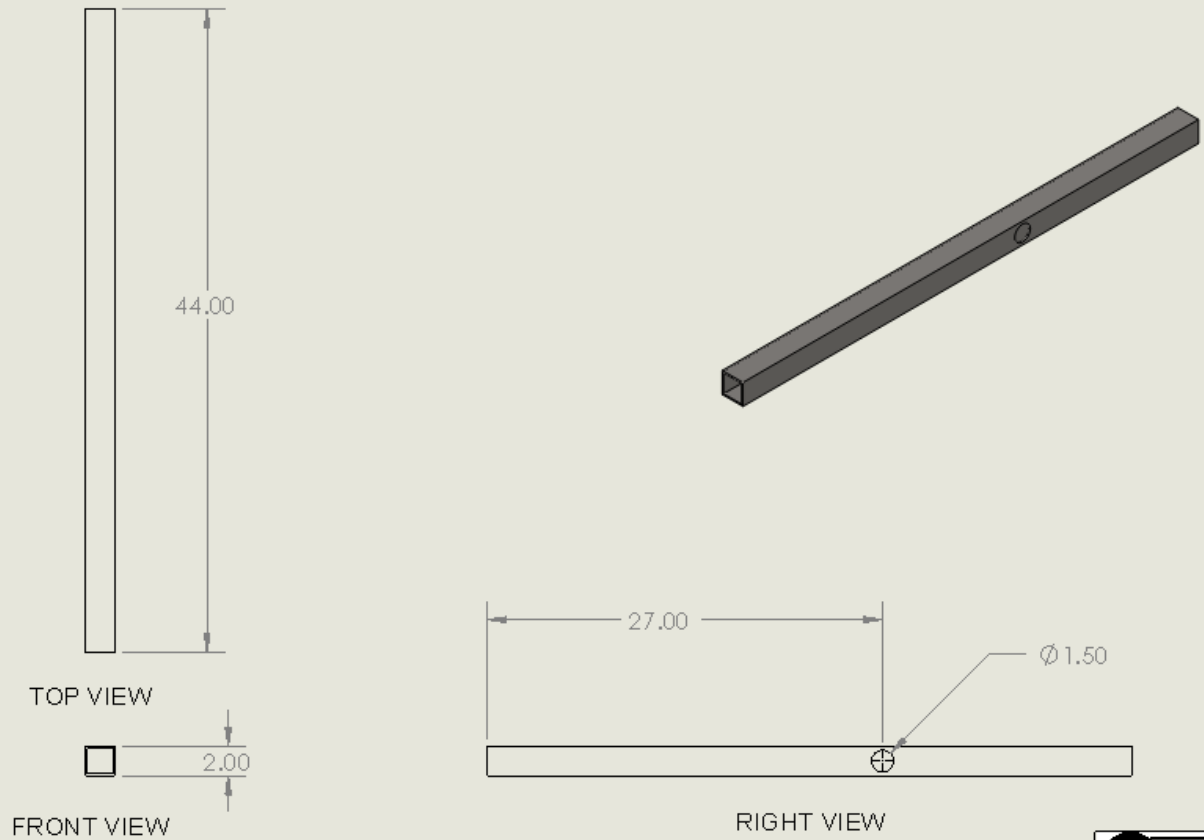

Worcester Polytechnic Intsitude

All dimensions are inches and degrees

Support 1

Default Tolerances

Part Number (12 of 31)	.1	(+)(-) .050
Quantity of Part 1	.12	(+)(-) .020
	.123	(+)(-) .005
	Angle	(+)(-) 1

Drawn by: Dumbell MQP Group
Scale: 1:10
Date: 4/29/2009

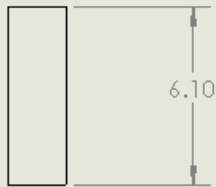

TOP VIEW

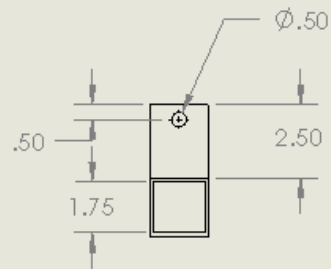
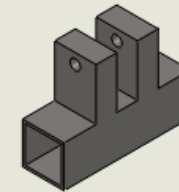

FRONT VIEW

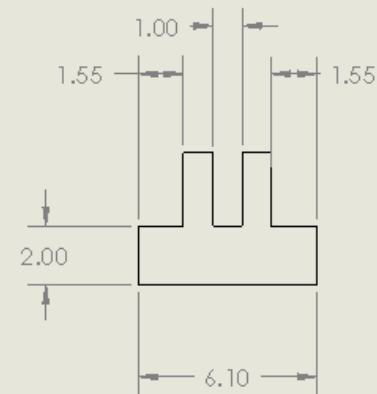

RIGHT VIEW



Worcester Polytechnic Institute

All dimensions are inches and degrees

Seat Holder

Default Tolerances

.1	(+/-) .050
.12	(+/-) .020
.123	(+/-) .005
Angle	(+/-) 1

Drawn by: Dumbell MQP Group

Scale: 1:33.3

Date: 4/29/2009

Part Number (13 of 31)

Quantity - 1



FRONT VIEW

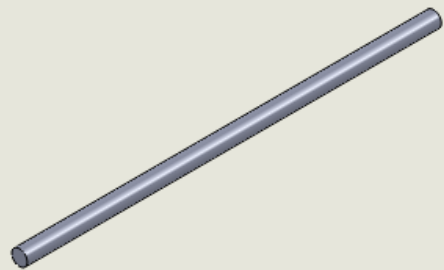

ISOMETRIC VIEW

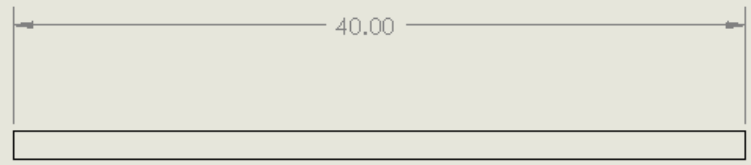

RIGHT VIEW



Worcester Polytechnic Institute

All dimensions are inches and degrees

BASE TRACK

Default Tolerances

Drawn by: Dumbell MQP Group

Part Number (14 of 31)

.1	(+)(-) .050
.12	(+)(-) .020
.123	(+)(-) .005
Angle	(+)(-) 1

Scale: 1:33.3

Date: 4/29/2009

Quantity - 1



TOP VIEW (SCALE 1:2)

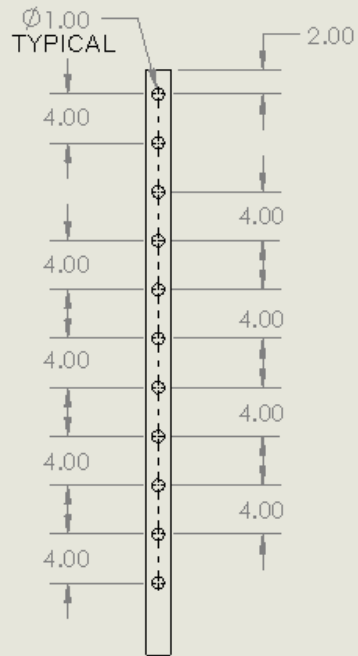

FRONT VIEW

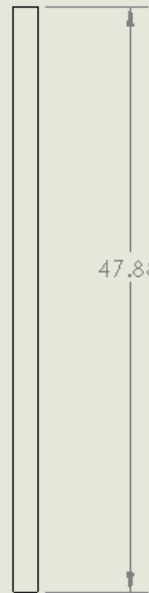

RIGHT VIEW



ISOMETRIC VIEW



Worcester Polytechnic Institute

All dimensions are inches and degrees

ARMS

Default Tolerances

.1	(+X-) .050
.12	(+X-) .020
.123	(+X-) .005
Angle	(+X-) 1

Drawn by: Dumbell MQP Group

Part Number (15 of 31)

Quantity of Part - 2

Scale: 1:16

Date: 4/29/2009



TOP VIEW

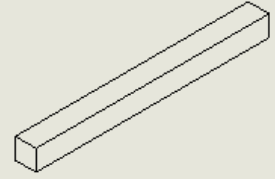

ISOMETRIC VIEW

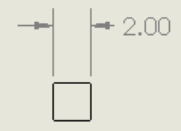

FRONT VIEW



RIGHT VIEW



Worcester Polytechnic Institute

All dimensions are inches and degrees

BACK BASE SUPPORT

Default Tolerances

.1	(+X) .050
.12	(+X) .020
.123	(+X) .005
Angle	(+X) 1

Drawn by: Dumbell MQP Group

Scale: 1:8

Date: 4/29/2009

Part Number (16 of 31)

Quantity - 1



TOP VIEW

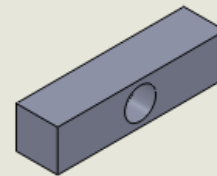

ISOMETRIC VIEW

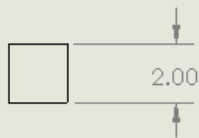

FRONT VIEW

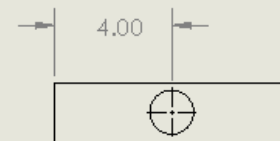

RIGHT VIEW



Worcester Polytechnic Institute

All dimensions are inches and degrees

FRONT TRACK SUPPORT

Default Tolerances

.1	(+X) .050
.12	(+X) .020
.123	(+X) .005
Angle	(+X) 1

Drawn by: Dumbell MQP Group

Part Number (17 of 31)

Quantity - 1

Scale: 1:5

Date: 4/29/2009

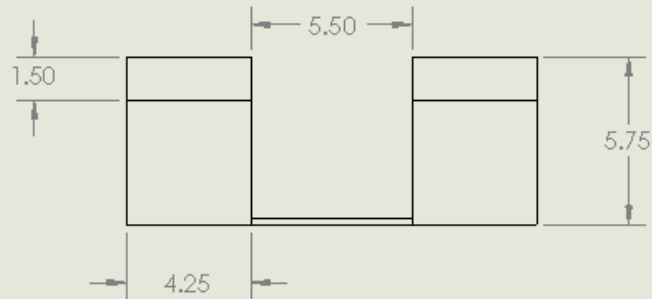

TOP VIEW

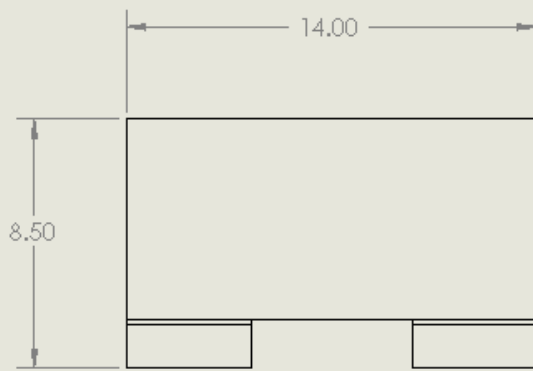

FRONT VIEW

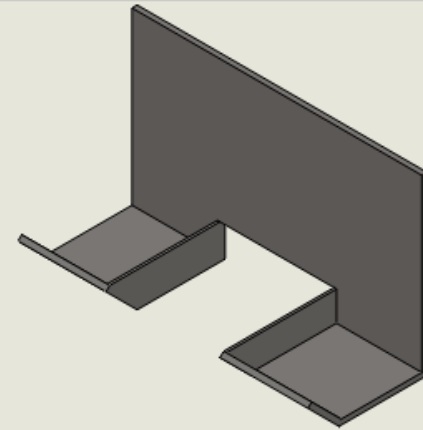

ISOMETRIC VIEW

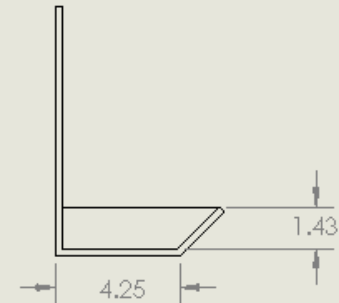

RIGHT VIEW



Worcester Polytechnic Intsitute

All dimensions are inches and degrees

Default Tolerances

.1	(+/-) .050
.12	(+/-) .020
.123	(+/-) .005
Angle	(+/-) 1

DUMBBELL HAND

Part Number (18 of 31)

Quantity - 2

Drawn by: Dumbell MQP Group

Scale: 1.5

Date: 4/29/2009

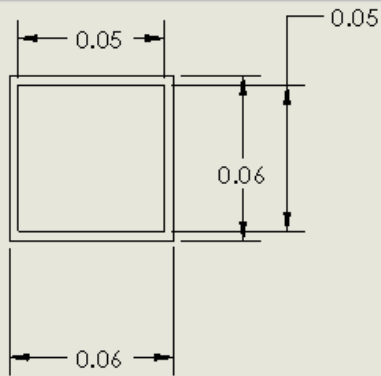

TOP VIEW

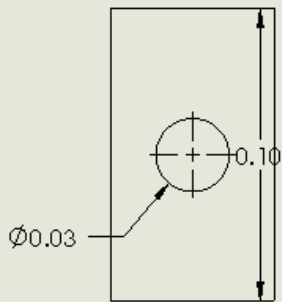
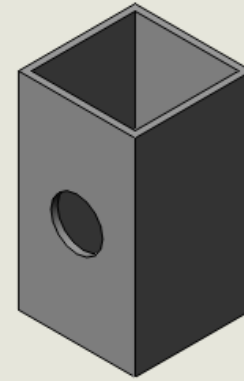

FRONT VIEW



RIGHT VIEW



Worcester Polytechnic Institute

All dimensions are
inches and degrees

Arm Adjuster

Default Tolerances

.1	(+)(-) .050
.12	(+)(-) .020
.123	(+)(-) .005
Angle	(+)(-) 1

Drawn by: Dumbell MQP Group

Scale: 1:33.3

Date: 4/29/2009

Part Number (19 of 31)

Quantity - 2

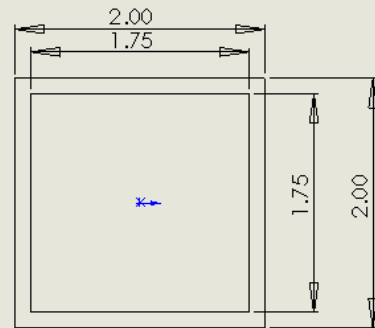

Top View

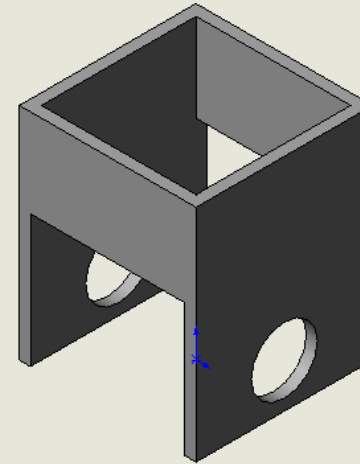

Isometric View

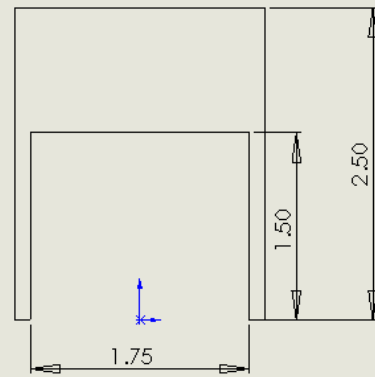

Front View

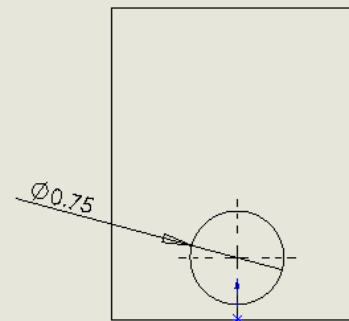

Side View



Worcester Polytechnic Institute

All dimensions are inches and degrees

Default Tolerances

.1	(+)(-) .050
.12	(+)(-) .020
.123	(+)(-) .005
Angle	(+)(-) 1

Wheel Support

Drawn by: Dumbell MQP Group

Scale:1:1

Date:4/29/2009

Part Number: 20 of 31

Quantity: 4

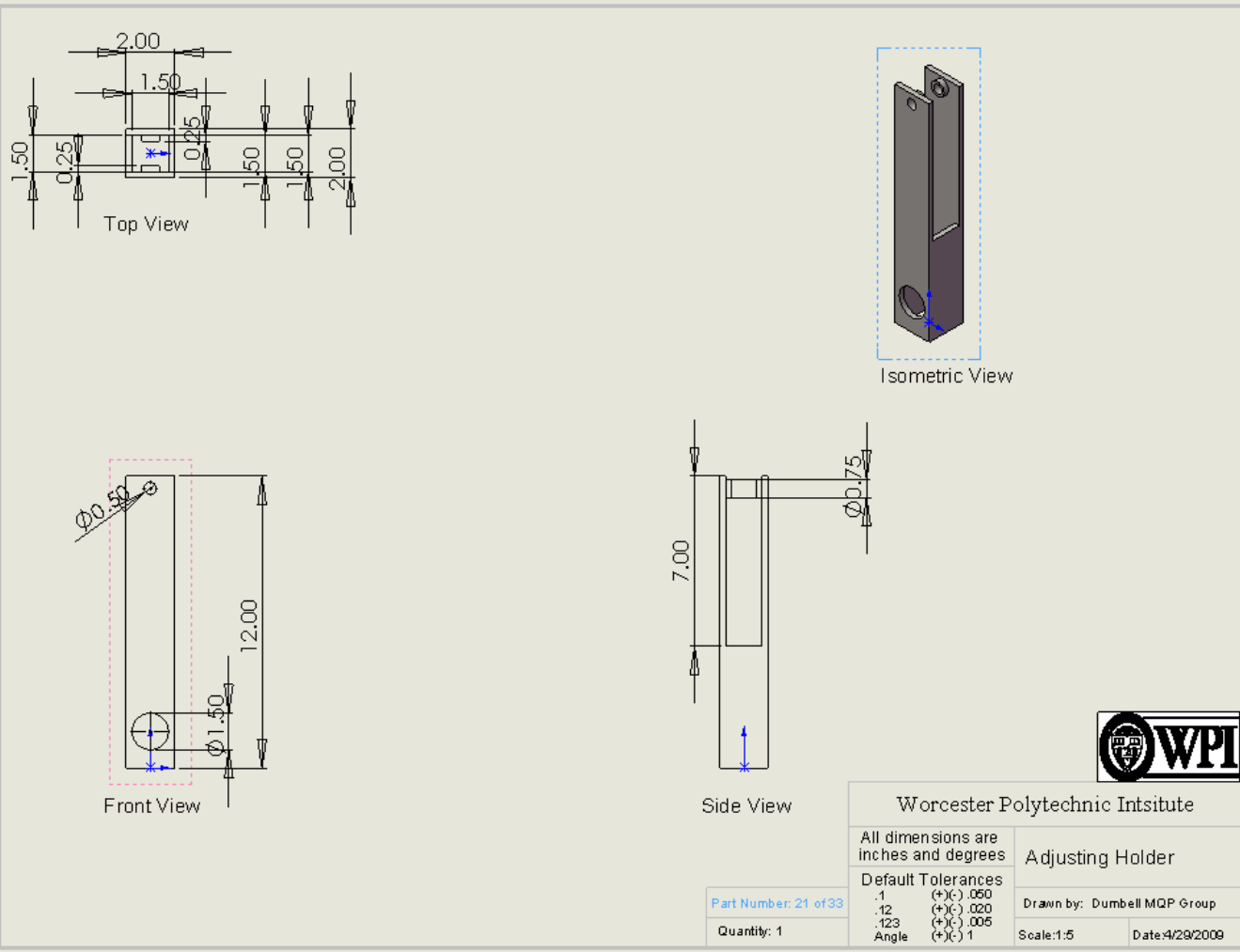

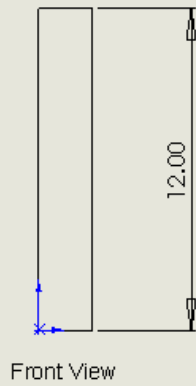
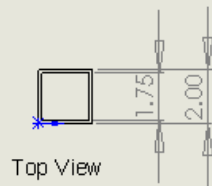

Worcester Polytechnic Institute

All dimensions are inches and degrees

Step Support

Default Tolerances

Drawn by: Dumbell MQP Group

.1 (+) (-) .050
 .12 (+) (-) .020
 .123 (+) (-) .005
 Angle (+) (-) 1

Scale: 1.5

Date: 4/29/2009

Part Number: 22 of 33

Quantity: 2

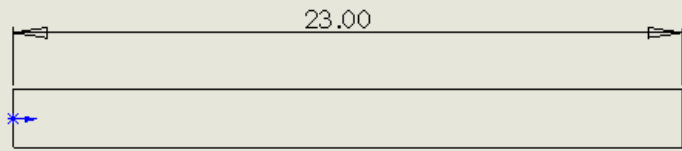

Top View

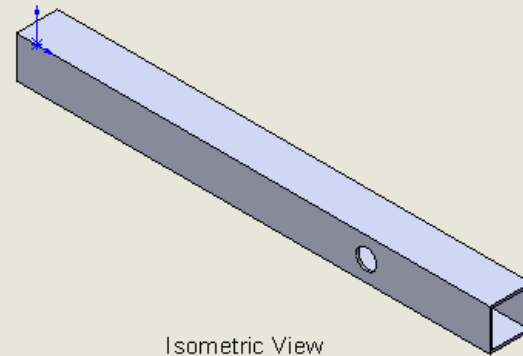

Isometric View

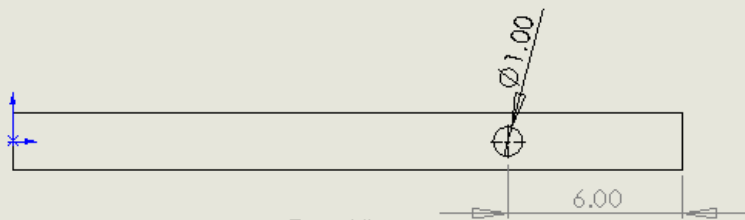

Front View

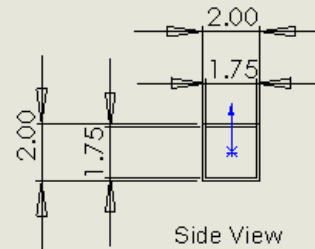

Side View



Worcester Polytechnic Institute

All dimensions are inches and degrees

Foot Lever Support

Default Tolerances

.1	(+)(-) .050
.12	(+)(-) .020
.123	(+)(-) .005
Angle	(+)(-) 1

Drawn by: Dumbell MQP Group

Scale:1:5

Date:4/29/2009

Part Number: 23 of 31

Quantity: 2

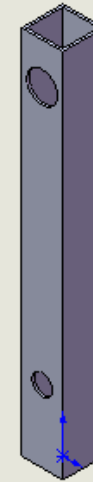
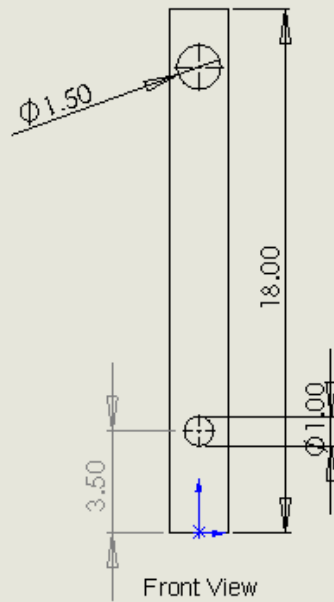
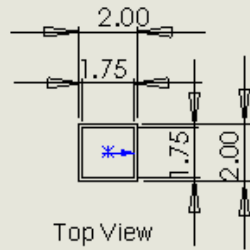

Isometric View



Worcester Polytechnic Institute

All dimensions are inches and degrees

Foot Lever

Default Tolerances

.1	(+)(-) .050
.12	(+)(-) .020
.123	(+)(-) .005
Angle	(+)(-) 1

Drawn by: Dumbell MQP Group

Part Number: 24 of 31

Quantity: 1

Scale: 1.5

Date: 4/29/2009

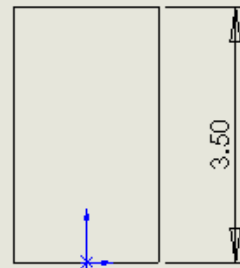
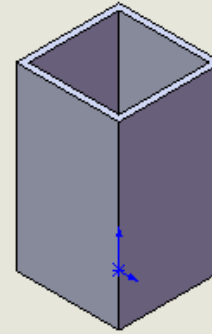
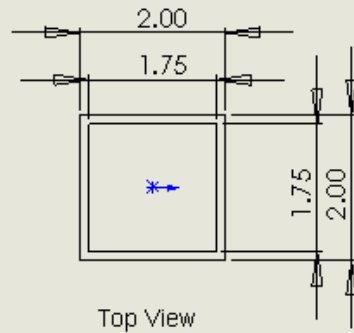

Worcester Polytechnic Institute

All dimensions are inches and degrees

Foot Lever Base

Default Tolerances

Drawn by: Dumbell MQP Group

Part Number: 25 of 31

.1	(+)(-) .050
.12	(+)(-) .020
.123	(+)(-) .005
Angle	(+)(-) 1

Scale: 1:2

Date: 4/29/2009

Quantity: 2

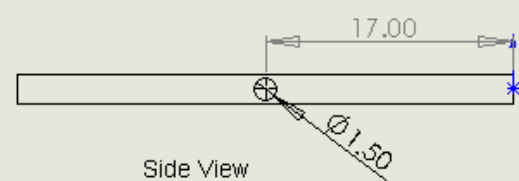
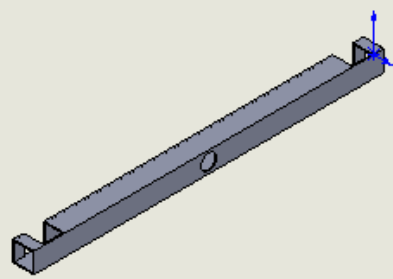
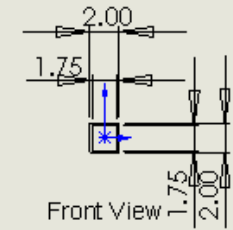
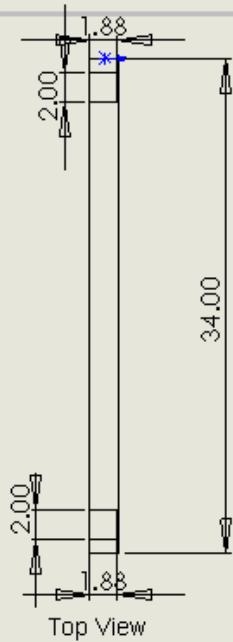

Worcester Polytechnic Institute

All dimensions are inches and degrees

Arm Base

Default Tolerances

.1	(+)(-) .050
.12	(+)(-) .020
.123	(+)(-) .005
Angle	(+)(-) 1

Drawn by: Dumbell MQP Group

Part Number: 26 of 31

Quantity: 1

Scale: 1:10

Date: 4/29/2009



Top View

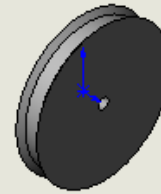

Isometric View

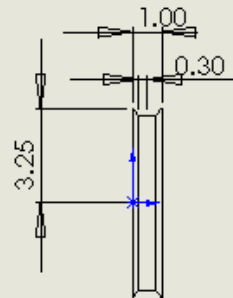

Front View

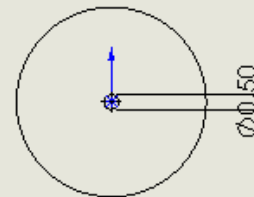

Side View



Worcester Polytechnic Institute

All dimensions are inches and degrees

Pulley

Default Tolerances

Drawn by: Dumbell MQP Group

Part Number: 27 of 31

Quantity: 3

.1	(+)(-) .050
.12	(+)(-) .020
.123	(+)(-) .005
Angle	(+)(-) 1

Scale: 1.5

Date: 4/29/2009

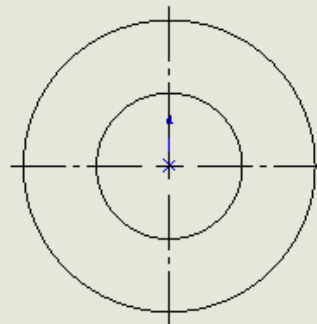
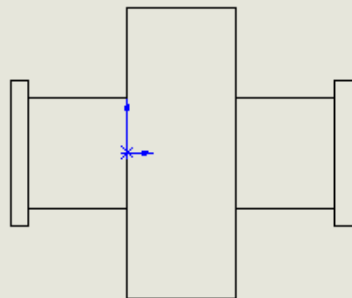
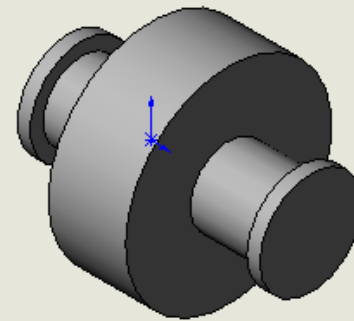
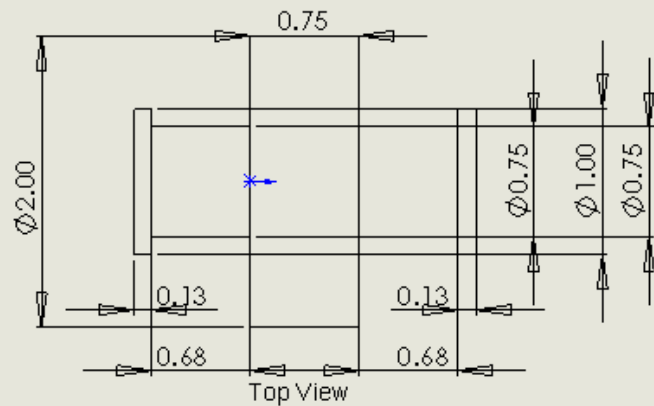

Worcester Polytechnic Institute

All dimensions are inches and degrees

Wheel

Default Tolerances

.1	(+)(-) .050
.12	(+)(-) .020
.123	(+)(-) .005
Angle	(+)(-) 1

Drawn by: Dumbell MQP Group

Part Number: 28 of 31

Quantity: 4

Scale: 1:1

Date: 4/29/2009

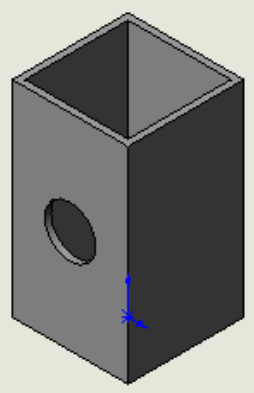
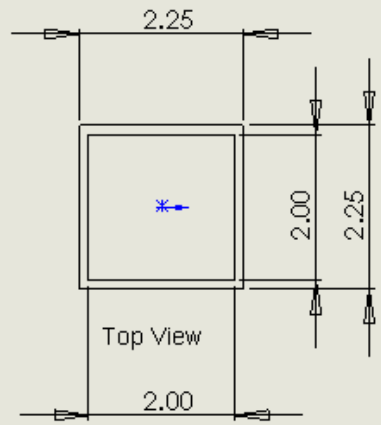

Isometric View

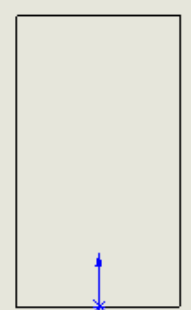
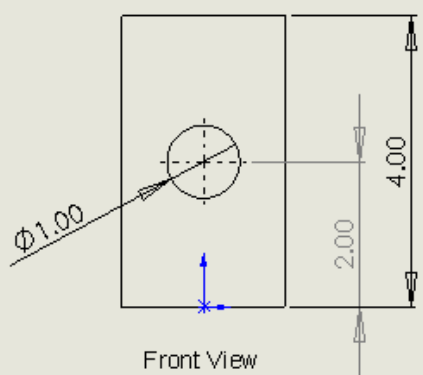

Side View



Worcester Polytechnic Institute

All dimensions are inches and degrees

Arm Adjuster

Default Tolerances

.1	(+)(-) .050
.12	(+)(-) .020
.123	(+)(-) .005
Angle	(+)(-) 1

Drawn by: Dumbell MQP Group

Part Number: 29 of 31
Quantity: 2

Scale: 1:2 Date: 4/29/2009

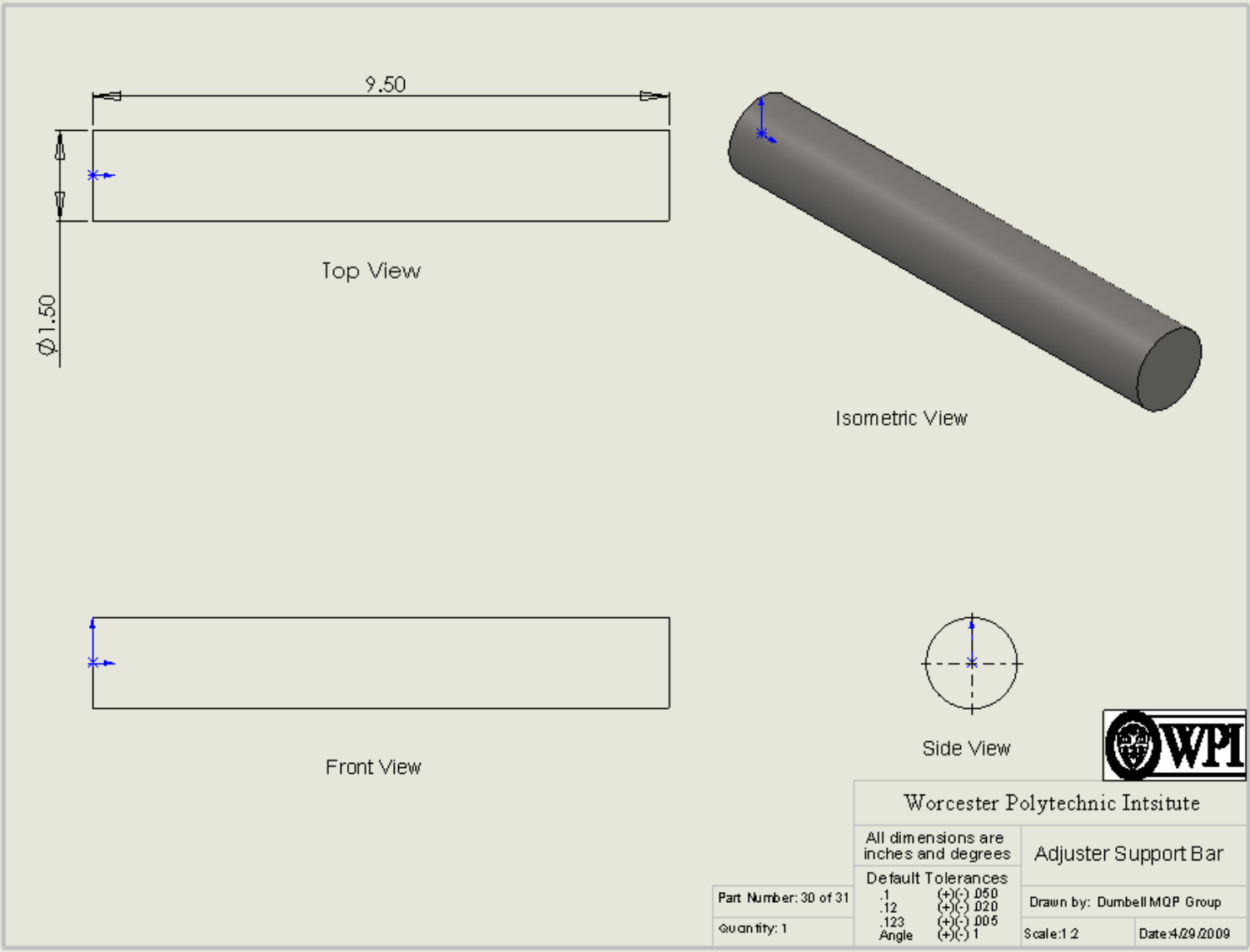

Worcester Polytechnic Institute

All dimensions are inches and degrees

Adjuster Support Bar

Default Tolerances

Drawn by: Dumbell MQP Group

Part Number: 30 of 31	.1	(+)(-) .050
Quantity: 1	.12	(+)(-) .020
	.123	(+)(-) .005
	Angle	(+)(-) 1

Scale: 1:2 Date: 4/29/2009

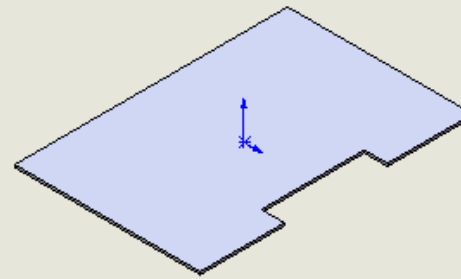
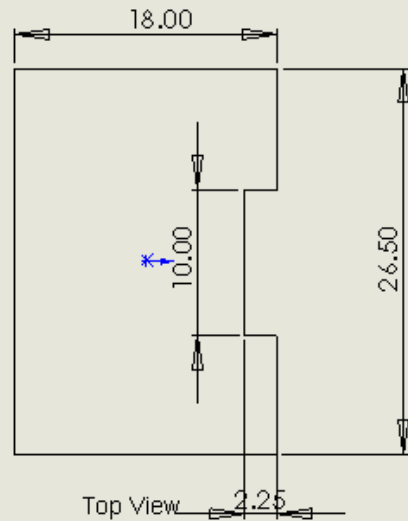

Isometric View

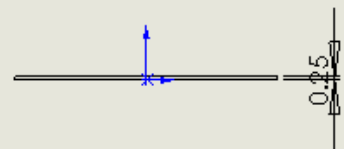

Front View

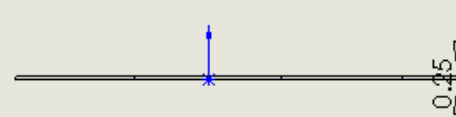

Side View



Worcester Polytechnic Institute

All dimensions are inches and degrees

Step

Default Tolerances

.1	(+)(-) .050
.12	(+)(-) .020
.123	(+)(-) .005
Angle	(+)(-) 1

Drawn by: Dumbell MQP Group

Part Number: 31 of 31

Quantity: 1

Scale: 1:10

Date: 4/29/2009