

# Tidal Energy Surveying Tool

*A Major Qualifying Project*

*Submitted to the Faculty of*

WORCESTER POLYTECHNIC INSTITUTE

*In partial fulfillment of the requirements for the*

*Degree of Bachelor of Science of  
Electrical and Computer Engineering*



By

Swan Htet

Nicholas Nugent

Zhang Liang

Date: April 25, 2019

Submitted to:

Professors Stephen Bitar and Yousef Mahmoud of Worcester Polytechnic Institute

*This report represents work of WPI undergraduate students submitted to the faculty as evidence of a degree requirement. WPI routinely publishes these reports on its web site without editorial or peer review. For more information about the projects program at WPI, see <http://www.wpi.edu/Academics/Projects>*

## Abstract

The use of tidal energy as a renewable energy source has yet to develop in the same rate as Solar and Wind energy technologies. Currently, most tidal energy applications are only focused on large scale installations and thus, with our project we wanted to explore the possibility of implementing a tidal energy monitoring system on a small-scale basis. In this project, we created a production design of a tidal energy monitoring system comprised of multiple underwater sensing devices. Each underwater sensing device would be equipped with its own propeller for power and also to record the current at its location and transmit this data back to the data relay buoy on the surface using SONAR communication. The buoy would then relay this information back to a shore station using cellular communication. Due to the constraints of using a SONAR communication protocol and the lack of mechanical expertise required to design a propeller, we decided instead to create a proof of concept which we could use to demonstrate how our device would function. Instead of using SONAR communication, we used a Wifi module and removed the data relay buoy. We also replaced the propeller with a generator to measure the flow of water. This data would then be transmitted wirelessly to an SQL database. Our project, a proof of concept device for a potential production design, demonstrates the constraints in the tidal energy space and aims to encourage more research and development in the field.

# Statement of Authorship

Nicholas Nugent: 2, 3.1, 3.2.1, 3.2.2, 3.3.1, 3.3.2, 3.4.1, 3.4.2, 3.4.3, 3.4.5, 4.1, 4.2, 4.2.1, 4.2.2, 4.2.3, 4.3, 4.3.1, 4.3.2, 4.3.3, 4.3.4, 5.2, 6.1, 6.2, Appendix C, Appendix E, Appendix F, Formatting, Editing

Zheng Liang: 4.1, 5.1, 6.2, 7, Editing

Swan Htet: Abstract, Executive Summary, 1, 7

# Acknowledgements

We would like to thank Professors Stephen Bitar and Yousef Mahmoud for their insight and guidance throughout this project.

We would also like to thank Worcester Polytechnic Institute for allowing us the opportunity of working on the project.

And finally we would like to thank the entire Electrical and Computer Engineering Department for their support and assistance.

# Executive Summary

Currently, most of the energy harvesting techniques in the tidal energy space are only focused on large-scale applications rather than small-scale devices. However, while the focus is mainly on large-scale applications, we wanted to demonstrate the potential for growth that small-scale applications could have in the tidal energy space.

The goal of our project was to create a small-scale tidal energy monitoring system for deployment in an area in order to determine its suitability for potential tidal energy installations. We decided that we wanted our device to be able to monitor and transmit real-time data on currents for it to be able to compete with current market competitors. We created a design based on what we thought the tidal energy space had a demand for and then created a proof of concept to demonstrate how our device would operate.

In order to compete with existing products, we devised some design objectives and constraints for our device. Our goal was to ensure that the device would be self-powered so that it would use the flow of the tides to power its data transmission. Additionally, this would also mean that the device could be deployed for a longer period of time and without much supervision. Another objective for our device was to use wireless communication to transmit data. For our production design, we used a SONAR communication protocol to transmit data from the underwater sensing unit to the buoy and then the buoy would use cellular communication to relay the data to a shore station where the data is stored in an SQL database. With this design, the shore station would become a virtual location and would be easy to access and keep track of current measurements.

Two more objectives we had for our project were to ensure the accuracy of our measurements and finally, to ensure a long deployment life for our object. This means that there should be minimal need to maintain our device once it has been deployed and it should work accurately until its next maintenance schedule. This was one of our key goals as we decided early on in our project on the importance of having a device that can work for a long period of time with minimal supervision. With the harsh underwater conditions in mind, we designed our product to be able to deal with foul prevention as well as other faults that could occur to the device as a result of its environment.

Furthermore, we also included some constraints to help us identify how our device would differ from existing devices currently in the market. Constraint one was to ensure that our device would be less expensive than competing products. This was a key constraint that we established early on in our project when we learned about the high costs of current tidal energy applications. Specifically, we looked at the Acoustic Doppler Current Profilers (ADCP) manufactured by Teledyne Marine and used by NOAA. They have different models used for different bodies of water and different currents. As the cost of one ADCP was over \$20,000, we wanted to make this price lower so that it would be much cheaper to deploy one device and also so that multiple devices could be deployed. Because our product is focused on the small and micro scale tidal energy installations, we recognized that cost would be a major factor for our device to be able to compete with existing models. Additionally, our product would be different from the ADCPs in that we would be using real-time scanning instead of prediction models to measure current data at the device's location.

We also identified two more constraints to help guide us in developing our device. First, because our device was planned to be set in a certain location, we decided that there would be no need to use GPS. Also, because our device is designed to use only a small amount of the generated energy, GPS was not an ideal option because it would take much of the overall power consumption and would also shorten the device's deployment cycle. Besides this, we also included a shore station database capable of receiving real-time data from the buoy relayed from each of the underwater sensing devices. Because of this shore station, we no longer need to include a GPS into our design. Finally, our last constraint was to have the device waterproof. Our device is designed to be deployed in coastal areas of 10-20 metres depth in order to effectively measure tidal stream data and in order to ensure that it accurately tracks data, we will apply water repellent coatings and use a waterproof enclosure to store our device.

Using the design objectives and constraints we outlined, we created an electrical design for a production version of the Tidal Energy Surveying Tool. Our design was limited only to the electrical and system aspects of the product due to the lack of mechanical engineering expertise required to design a propeller appropriate for this application.

Our system, the Tidal Energy Surveying Tool, is comprised of three individual physical devices: The Underwater Sensing Device, the Data Relay Buoy, and the Shore Station. We decided on a system of three distinct devices so that we could be flexible based

on our customers needs. The system would be deployed high traffic areas such as bays, harbors, and inlets and as such, it was designed not to cause any obstructions or impair nautical navigation.

The underwater sensing device would sit underwater, record the current at its specific location and transmit this data to the data relay buoy using the energy generated from its own propeller. In our system, we would have multiple Underwater Sensing Devices deployed along a coastal area in order to track the tidal stream data at each location.

The next device is the data relay buoy. We implemented a data relay buoy that would be able to relay measurement data from multiple underwater sensing devices in a ~3km radius to a shore station. This device mainly acts as a communication bridge between the underwater sensing devices and its end user. It receives data from the underwater sensing devices by using a DSPComm Aquatrans SONAR modem and then transmits that data to a shore station using the cellular GSM protocol.

The third component of our system is the shore station. We decided to use the cellular network so that the shore station would be a virtual location rather than a physical one. The data relay buoy can use the GSM protocol to establish a connection to the end user's database server. For our design, we used a SQL database to demonstrate this concept. Once the database is updated, the end user will then have the ability to perform any calculations or analysis on the data. Each underwater sensing device will only transmit the measured data and its unique identifier.

After we designed the production version of our device, we realized that it was impractical to build a working prototype. The issues were that the cost of a SONAR modem exceeded the budget of the entire project, and that it also required extensive mechanical designs.

In order to implement our concept, we assembled a proof of concept device that would be able to demonstrate the viability of our system. We made a number of conceptual changes to the design such as replacing SONAR with a Wifi module. No longer using SONAR, our device would not need to be submerged in water. Another change we made was in terms of the mechanical design. Instead of a propeller, gearbox, and generator, we implemented a micro-hydro generator that allowed us to test the flow velocity of the water.

Specifically, from our project we can identify two main improvements that we thought we could have made. Firstly, instead of using the power generated from the turbine

to determine the flow velocity of water, we should have just included a speed sensor that tracks this information. Another improvement that we would have liked to see in our project is the implementation of the mechanical components of our design. In addition to this, we would also like to see the development of an open-source SONAR communication protocol so that SONAR devices can become cheaper and more accessible.

While we were ultimately unable to test the functionality of our PCB, we were still able to achieve our design objectives and constraints with our production design. Overall, our device fulfills a need for a simple monitoring system with real-time current scanning data to access the suitability of small-scale tidal stream installations. Our device is one solution to fulfilling this potential need in the tidal energy market and we are interested to see how the tidal energy space advances technologically to find solutions to accommodate for this need. Additionally, it is our hope that this technological advancement can lead to more progress in the tidal energy space so that tidal energy can be utilized to its full potential as a renewable source of energy.



# Table of Contents

<b>Abstract</b>	<b>1</b>
<b>Statement of Authorship</b>	<b>2</b>
<b>Acknowledgements</b>	<b>3</b>
<b>Executive Summary</b>	<b>4</b>
<b>Table of Contents</b>	<b>8</b>
<b>Table of Figures</b>	<b>10</b>
<b>1 Introduction</b>	<b>11</b>
<b>2 Problem Statement</b>	<b>12</b>
<b>3 Background</b>	<b>13</b>
3.1 Definitions and General Information:	13
3.2 Modern Tidal Power History and Examples:	17
3.2.1 Potential Energy Harvesting:	17
3.2.2 Kinetic Energy Harvesting:	20
3.3 Customers:	24
3.3.1 NOAA (and related organizations)	24
3.3.2 Micro Tidal Stream Generators	24
3.4 Competitors:	25
3.4.1 Acoustic Doppler Current Profiler (ADCP)	25
3.4.2 Shore-based Current Meters	26
3.4.3 Shallow Water Drifter	27
3.4.4 Deep Ocean Drifter	28
<b>4 Methodology</b>	<b>29</b>
4.1 Design Objectives and Constraints	29
Objective 1: Self powered	29
Objective 2: Wireless Communication	30
Objective 3: Accurate Measurement	30
Objective 4: Long Deployment Life	31
Constraint 1: Less Expensive than Competing Products	31
Constraint 2: GPS is not available	31
Constraint 3: Waterproof	32
4.2 Electrical Design for Production Version	32
4.2.1 Underwater Sensing Device	34
4.2.2 Data Relay Buoy	36

4.2.3 Shore Station	38
4.3 Proof Of Concept	39
4.3.1 Block Diagram	39
4.3.2 Circuit Schematic	40
4.3.3 Microcontroller Programming	42
4.3.4 SQL Database Set-up	43
<b>5 Implementation and Testing</b>	<b>45</b>
5.1 PCB Layout	45
5.2 Testing Apparatus	46
<b>6 Results</b>	<b>48</b>
6.1 Measurement Test Results	48
6.2 PCB Testing Results	49
<b>7 Conclusion and Future Works</b>	<b>51</b>
<b>References</b>	<b>52</b>
Appendix A: Large Form Production Version Block Diagram	55
Appendix B: Large Form Proof of Concept Block Diagram	56
Appendix C: Production Version Block Diagram Specifications	57
Appendix D: Full Page Circuit Schematic	58
Appendix E: Microcontroller Measurement Code	59
Appendix F: PHP Code	61

## Table of Figures

Figure 3.1: Moon's Gravity and Tides	14
Figure 3.2: Maps of Tidal Cycles	14
Figure 3.3: Types of Tides	15
Figure 3.4: Medieval Tidal Mill	16
Figure 3.5: Tidal Barrage Diagram	17
Figure 3.6: Tidal Lagoon	18
Figure 3.7: Rance Power Station Scale Model	19
Figure 3.8: Rance Power Station	19
Figure 3.9: Axial Tidal Turbine	20
Figure 3.10: Helical Cross-Flow Turbine	21
Figure 3.11: Oscillating Hydrofoil	22
Figure 3.12: Tidal Kite	22
Figure 3.13: Acoustic Doppler Current Profiler	25
Figure 3.14: Shore Based Current Meter	26
Figure 3.15: Shallow Water Drifter	27
Figure 3.16: Deep Ocean Drifter	28
Figure 4.1: Block Diagram of Production Device Concept	31
Figure 4.2: Block Diagram of Underwater Sensing Device	32
Figure 4.3: Block Diagram of Data Relay Buoy	37
Figure 4.4: SONAR Networking Example	38
Figure 4.5: Proof of Concept Block Diagram	40
Figure 4.6: Proof of Concept Circuit Schematic	41
Figure 4.7: MySQL Database Example	44
Figure 5.1: PCB Layout	45
Figure 5.2: Testing Apparatus	46
Figure 6.1: Velocity vs Generator Power Chart	48
Figure 6.2: PCB Layout Error	49

# 1 Introduction

Tidal Energy, much like Solar and Wind, is a renewable energy using the flow of the tidal currents that provides us an alternative from fossil fuels. With the rapidly increasing threat of climate change, it is imperative that we start adopting the use of renewable sources of energy. In 2018, the U.S Energy Information Administration reported that fossil fuels accounted for 80% of total energy consumption [1]. While the consumption of renewable energy increased from 15% in 2016 to 18% in 2017, there is no doubt that we are still heavily reliant on fossil fuels for our energy solutions. Recent technological advancements in solar and wind power applications have increased the availability of renewable energy installations and have also made them more affordable. While wind and solar options have become readily available, there has yet to be the same level of advancement in the field of tidal energy. Currently, the United Kingdom leads the way in having most tidal energy resources. The country has the potential to generate up to 20% of its current electrical needs from tidal and wave energy [2]. As more research is conducted in the tidal energy space, we hope it will also lower the overall costs so that it can become more applicable.

Inspired by a combined interest in the oceans and renewable energy, we decided to research the up and coming tidal energy space. During the course of that research we found some problems with the existing current measurement devices when it comes to measures specific nearshore locations. Based on this we came up with a number of product goals that will solve this problem and make it viable in the market. Our hope is that our device TEST (Tidal energy surveying tool) can not only improve techniques for tidal energy generators placement and help make small and micro scale tidal energy generation more practical, but also to make real-time current sensing data more available.

## 2 Problem Statement

Knowing the tidal stream current in a specific location is not only useful for navigation but also for implementation of tidal stream generation. Unlike the tidal height, which is widely monitored, tidal currents are not. Right now to make tidal current predictions NOAA carries out studies on areas of interest using Acoustic Doppler Current Profilers. These studies are long, costly and do not provide real-time data, as they are used to make prediction models for that area. These models can have limited accuracy over time due the large impact of the ever changing seafloor on the current. To solve this we propose to make a small affordable device that can be deployed for long periods to provide real-time data on the tides at specific locations. Not only will this be useful for navigation and government agencies like NOAA, but also for groups looking to install small scale tidal stream energy generation.

## 3 Background

---

### 3.1 Definitions and General Information:

Here are some usual nautical terms that will be used throughout this paper:

**High Tide:** The highest point for a particular tidal cycle.

**Low Tide:** The lowest point for a particular tidal cycle.

**Ebb Tide:** The period between high and low tide when the sea is receding.

**Flood Tide**(also called Flow tide): The period between low and high tide when the sea is incoming.

**Slackwater:** A short period in between Ebb and Flood when the water is completely unstressed, meaning there is no tidal stream in either direction. Usually near high and low tide

**Tidal Range:** Difference between high and low tides.

**Spring Tide:** Most extreme tidal range, occurs when the Sun and Moon are aligned, happens twice a lunar cycle at Full and New Moons.

**Neap Tides:** Lowest tidal range, occurs when the Sun and Moon are at 90° when viewed from earth, happens twice a lunar cycle at the first and last quarters of the Moon phases.

**Tidal constituents** [3][4]: The total tide result at a location is made of smaller forces that give each location its characteristic. The primary constituents are the Earth's rotation, the position of the Moon and Sun, bathymetry(the depth and contours of the seafloor), and the Moon's altitude above the equator. In most locations, the dominant constituent is the "principal lunar semidiurnal" also known as M2 which is the effect of the moon's gravitational pull on the oceans resulting in a bulging effect with the water on the near and far sides of the moon "extending" out and lateral sides "shrinking" in. Below is an exaggerated image depicting this phenomenon.

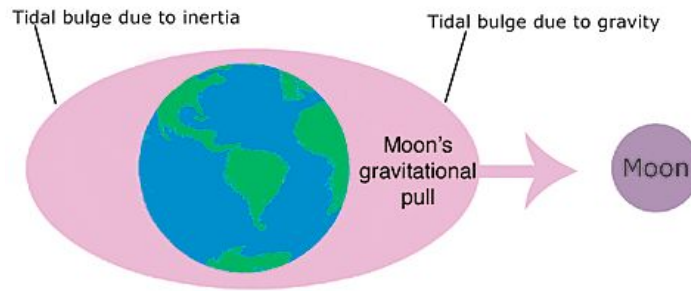

Figure 3.1 shows a diagram of the Moon's gravitational pull and the Earth's tides

The period of M2 is half of a lunar day or 12 hours and 25.2 minutes. While M2 is the most dominant constituent and the driving force of the tides globally, bathymetry is the most significant constituent along coastal regions. This means the shape of the shoreline and the ocean floor change the way the tides propagate through the area, resulting in some of the extreme tidal variations we see in places like the Bay of Fundy and Severn Estuary. It can also result in non-semidiurnal tides, where the waves along the coast do not follow the M2 pattern.

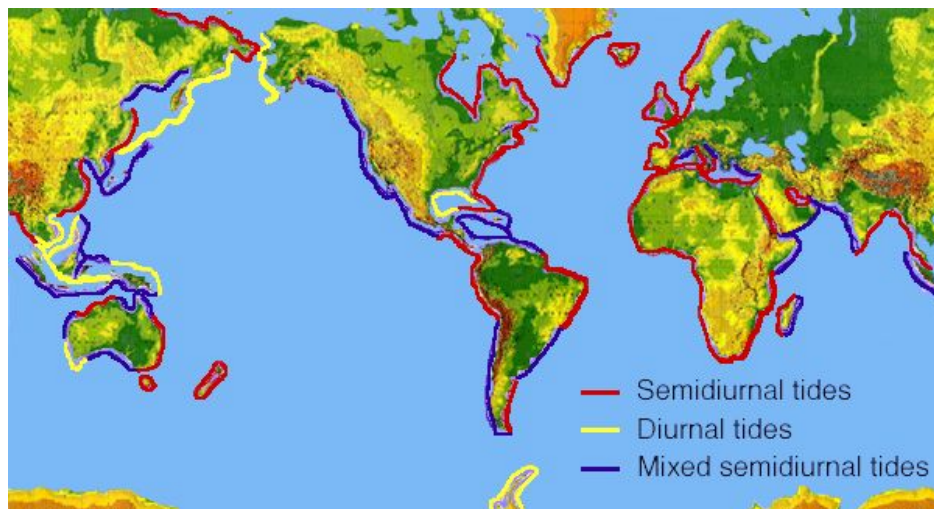

Figure 3.2 NOAA Map of tidal cycle types around the world. The type of tide is determined by the constituents in that location. See pics below for explanation of the types [5].

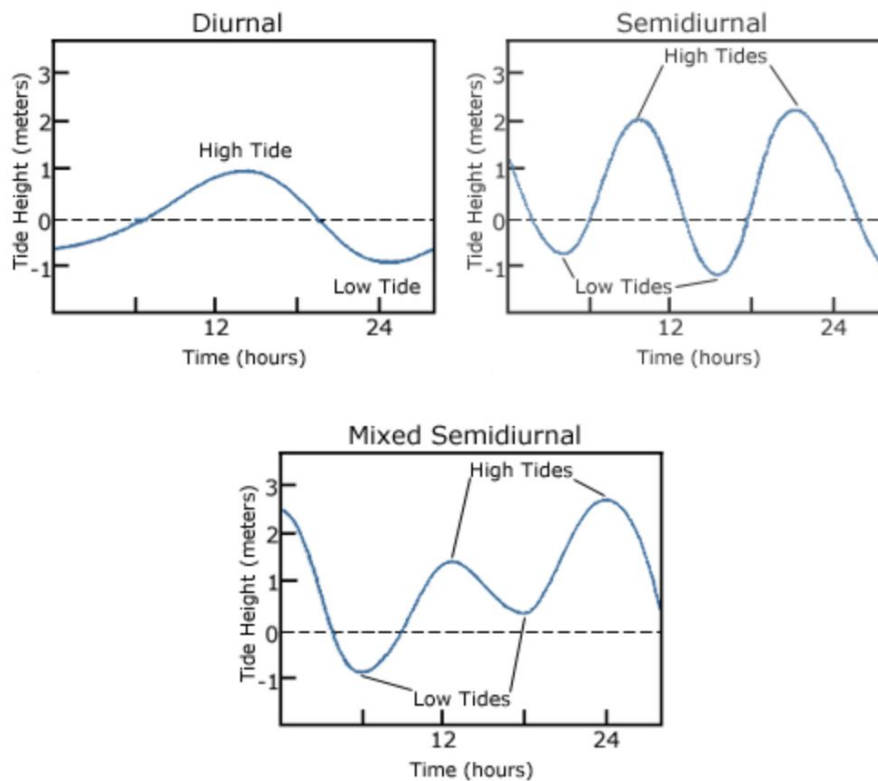

Figure 3.3 The type of tide is defined by frequency and relative amplitude of the high and low tides over one lunar day. As can be seen for Diurnal tides high and low tide occur once a lunar day. For Semidiurnal tides high and low tide occur twice a lunar day and they are of similar amplitude. For Mixed Semidiurnal high and low again occurs twice a day but there amplitudes are not similar [5].

The tidal predictions generated by the NOAA are based on the harmonic constituents present at that location and water level stations that record the height of the tide. They are a potential customer for our product. Right now they use the National Water Level Observation Network.

**Currents** [6]: In some regions, the primary currents are the ebb and flood tide streams locked to the tides. However this is not always the case, in fact, often it is more complicated, due to factors such a bathymetry and eddies. This makes the current analysis more complex than tidal analysis. Weather conditions can also affect the tidal currents, for example, a hurricane making landfall will bring a storm surge with it that will often overpower the tidal current.

For current predictions, the NOAA uses High-Frequency Radar to track surface current in some locations. They also deploy Acoustic Doppler Current Profilers in some areas



that can track the speed through the water column. Then they take this data and perform a harmonic analysis to find the tidal component they can use to create the current predicts. The issue is that because currents are highly dependent on bathymetry, and bathymetry can change with time these predictions are only very accurate for the location where the measurement was taken, around the time it was made, depending on the area. Also, the does not have permanent current stations set up, and they only conduct studies over a limited time.

### Beginnings and Early History:

While in modern times the use of tidal energy harvestings seems to been lagging other forms of renewable energy, it might date back to Roman times. The tide mill is the first documented harvesting of tidal energy. A tidal estuaries and inlets were dammed with a sluice gate, which acted like a door allowing the operators to control the flow of the water. The sluice would be opened to allow the rising tidal to enter the reservoir. The tide falls enough the sluice is opened allowing the stored water to exit and while doing so turn a water wheel, which could be used to grind, roll, or hammer. While they were not as prevalent as their river-based cousins, tide mills were used throughout the middle ages, most extensively on the British Isles but seen all throughout Northwest Europe and even North America after colonization.



Figure 3.4: A Medieval Tide Mill in Olhao Portugal Notice the sluice gates controlling the flow of water [7].

## 3.2 Modern Tidal Power History and Examples:

### 3.2.1 Potential Energy Harvesting:

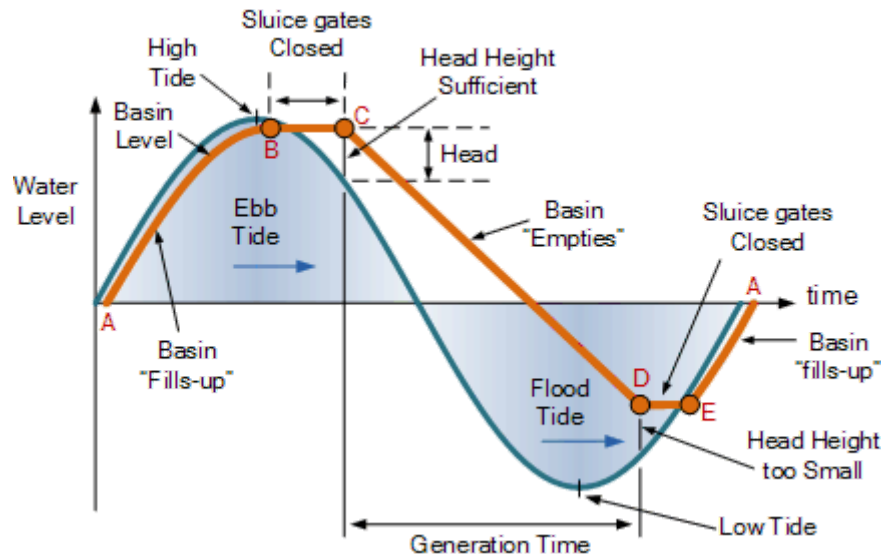

Figure 3.5: Shows the level in the tidal basin with respect to the tidal water level in order to generate energy. During the ebb tide, the basin fills as the tide raises, then the sluice gate closed to hold the basin at the high tide level. Then as the tide recedes “head” is created. That is the different in height between the basin and the tidal level on the other side of the barrage. The different in height is where the energy is created. The water in the basin is then released through the turbines until there is not enough head to generate energy. The sluice gates are then closed until the water level outside the barrage is higher than the level in the basin. At that point they are opened and the process starts again [8].

**Tidal Barrage:** A tidal barrage is most like the tidal mills from medieval times, and it harnesses the potential energy stored in the tidal range. It works much the same as tidal mills with the dams and sluices, but instead of driving a mill the water drives turbines to generate electricity. A tidal barrage also has the benefit of being able to generate some energy during the flood tide, whereas tidal mills only work during the ebb tide. The advantage of tidal barrages is that they can produce fairly large amounts of power. The disadvantages are that they are difficult and expensive to construct, pose many environmental problems, and restrict navigation along the river or bay they dam. They are also not a constant power source as they are unable produce energy during slackwater and have limited performance during flood tide which is not ideal from a power distribution perspective because they need the generation to

match the load and with this design, they are often out of phase. A newer technology that has yet to be implemented called a Tidal Lagoon seeks to fix this problem. A tidal lagoon uses two or more barrages and pumps to create a lagoon that can be controlled to produce a constant power output. Note while barrages take advantage of natural topography conducive to tidal generation, a tidal lagoon is entirely man-made.



Figure 3.6 Proposed Swansea tidal lagoon. This site is not yet built only proposed. It artificially creates a reservoir to run the turbines instead of relying on natural reservoirs like a tidal barrage [9].

The world's first tidal power station was the Rance Tidal Power Station, in Brittany, France and opened in 1966. It has a 240 MW peak output with an average of 57 MW off an 8-meter tidal range. It was quite expensive to build and took 20 years to pay itself off, a payback period that long is daunting to many governments. It has proved to be reliable though still in service 52 years later. The Rance plant has two generation modes: Ebb generation and Ebb and Flood generation. Most of the time the plant is in Ebb generation mode because the difference between low tide and upstream isn't large enough to generate electricity during flood tide. However during spring tide when the tidal range is greater, the differential is large enough to generate on both moving tides. The turbines can also act as pumps, pumping water behind the barrage at the end of the flood tide before slack water, allowing it to start up sooner [10].

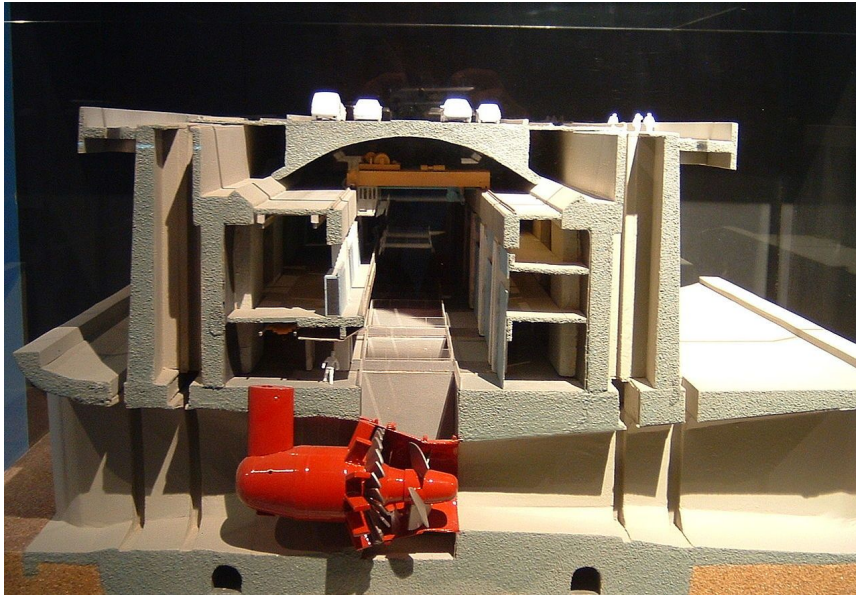

Figure 3.7 Rance Power Station scale model cross section. The sluice gates shown on either side control the flow of water over the turbines, and the walls hold back the force of the water like a dam [11].



Figure 3.8 Rance Power Station aerial [12].

Several smaller tidal barrages (<20 MW) were built in Canada, China, and Russia. The next large station came in 2011 and was built in South Korea. At 254 MW peak output, the Sihwa Lake Tidal Power Station overtook Rance as the world largest tidal power station. This station took advantage of an already existing seawall and added the needed sluices and turbines. The tidal range here is only 5.6 m on average which is significantly less than Rance. The Sihwa Lake plant only has ten 25.4 MW turbines during the Rance plant as twenty-four 10 MW turbines. This is most likely due to improves in turbine technology. Sihwa is a strictly one-way plant.



### 3.2.2 Kinetic Energy Harvesting:

Kinetic Energy Harvesting harnesses the power of the tidal stream currents rather than the tidal range. It offers many benefits over potential energy systems including lower environmental impacts, lower costs, and suitable for a broader range of locations.

#### **Turbine Based Generation:**



Figure 3.9 Axial turbine tidal generation [13].

*Axial Turbines:* Axial turbines mean that the shaft of the turbine is parallel to the flow of the water. They are much like wind power turbines that are largely in use today. The critical difference is that water is lower 800 denser than air which on the one hand allow them to generate power from a slower current and smaller blade diameter, but on the other require everything to be sturdier because the forces are much greater. Right now axial turbines need at least a 2 m/s current across them, but many require 2.5+ m/s. They also require relatively deep water to operate in typically 40+m deep, and have a larger blade diameter, up to 20m right now.

*Cross Flow Turbine:* The key difference from axial turbines is that CFTs rotate on an axis perpendicular to the flow. They are not nearly as popular as axial turbines for wind power generation, but some companies have found they have advantages including no need for pitch regulation or a gearbox, lower maintenance, quieter operation, and better performance in the severe wind. All of those advantages in wind power are even more

important for tidal energy generation due to the much harsher seawater conditions, the simpler, the better. Naturally, they come in two flavors vertical-axis CFTs and horizontal-axis CFTs. As of 2017, there were 26 different CFT devices listed by the European Marine Energy Centre [14]. They are quite diverse using different blade designs and designed for different requirements like avoiding channel blockage, so performance varies throughout the class.



Figure 3.10 A Helical CFT being deployed in Cobscook Bay, Maine [15].

*Oscillating Hydrofoils* [16]: An oscillating hydrofoil consists of a wing attached to a lever arm that is anchored to the seabed with a pivot point. As the tidal stream flows over the hydrofoil it creates lift, which causes the lever to rise. Once the wing reaches its peak, the angle between the wing and the flow has changed such that the forces are now reversed causing the wing to sink. The changing angle of attack between the wing and flow causes this oscillation which can then be converted to mechanical work and then electrical power. Oscillating Hydrofoils do face poor efficiency due to the time it takes to reverse the direction of the oscillation. The “Stingray” Hydrofoil was used in the early 2000s however it was discontinued due to poor performance. There has been continuing efforts to develop this technology; however, there is little published information as to their performance.

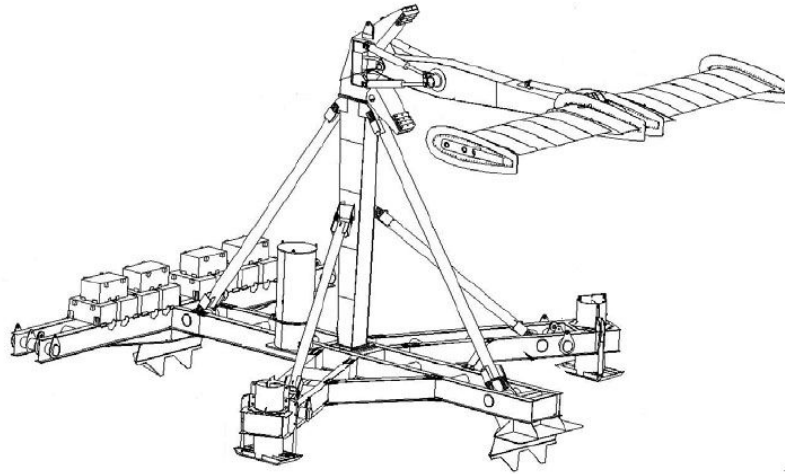

Figure 3.11 Oscillating hydrofoil. University of Strathclyde [16]

*Tidal Kites:* Tidal Kites are essentially axial turbines attached to a hydrofoil wing that is tethered to the seabed and meant to “fly” through the water column or at the surface. This is intended to increase the energy that can be extracted in slower tidal streams. These systems require deep water, i.e. 50 to 100 m. Marine equipment technology company Minesto has a tidal kite product on the market already, with a contract for an eventually 10 MW generation array in Holyhead deep Wales.

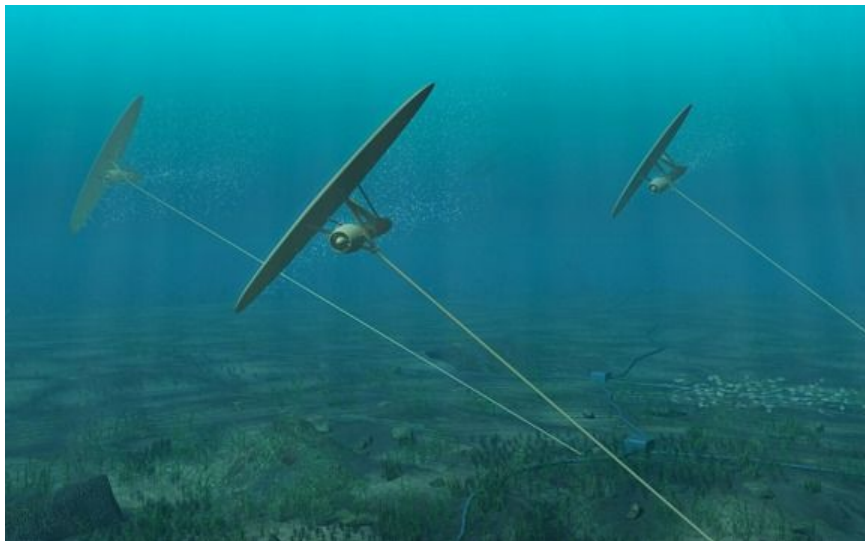

Figure 3.12 Minesto Deep Green Tidal Kite [17].

In 2016 Roberts et al. explored the current tidal power technologies in a paper for the *Journal of Ocean Engineering and Marine Energy* [18]. The review compared Axial turbines, Cross-flow turbines, Ducted turbines, Oscillating hydrofoils, Tidal Kites, Tidal Barrages, and Tidal lagoons by Power Density, Scalability, Durability, Maintainability, Economic

potential, and Environmental Impacts. Their goal was to find which technologies were most suitable for small-scale power generation. The Roberts et al. review found the following:

- Cross Flow Turbines appear to be well-suited due to their relatively high power densities and that the maximum device size isn't constrained by depth.
- Oscillating hydrofoils could be suitable for shallow-water applications if the efficiency issues can be sorted out.
- Tidal kites, barrages, and lagoons appear to be poorly suited to small scale power generation due to their required depth in the case of the tidal kite or in the case of barrages and lagoons the large investments required for similar performance as turbines.
- They point out that other micro-hydro technologies like Archimedes screws and gravitational water vortices, could prove to be viable for tidal power generation however they have not yet been investigated.

Tidal stream generation is starting to come online around the world, with small-scale operations in the UK, Northwest Europe, and North America. The first large-scale installation came online in 2017 located in Scotland's Inner Sound of Pentland Firth. Phase one is a 86 MW installation of over 50 turbines that is still ongoing. Right now around 12 MW is online and connected to the grid. The second phase hopes to increase generation to 398 MW which would make it the largest tidal power generation project in the world.

The consensus of many studies and tidal power device developers is that tidal stream generators all have fairly limited environmental effects. They have found that the low speed of the rotor is safe for fish. The primary concerns are the effects the devices have on the stream speed around the installation. The presence of the device can slow the current going downstream which can cause sediment transport, and the acceleration of the stream speed directly around the device can lead to scouring on certain seafloors. These concerns are considered relatively minor in most cases, but in shallower water, they would be more of a concern.

In the following section, we will explore potential customers and also analyze products that are currently used in the market. By doing this, we will have better insight on how to design a model that can more efficiently and cheaply perform the same tasks.



## 3.3 Customers:

### 3.3.1 NOAA (and related organizations)

NOAA stands for National Oceanic and Atmospheric Administration and is the American scientific agency within the United States Department of Commerce that focuses on the conditions of the oceans, major waterways, and the atmosphere. They provide many services to the American public including the National Weather Service, National Hurricane Center, National Ocean Service, and many others. One service included under their umbrella is providing tide and current charts for use in navigation. As discussed in the background section of this paper, the tides are fairly easy to create reliable models of using water level stations and models based on the tidal constituents. It is more difficult to create reliable models for the current due to its high dependence on bottom conditions and a high number of complex constituents. We believe we can improve on these models by providing continuous and real time data. We will dive into their current methods of creating these models in the next part of this section.

### 3.3.2 Micro Tidal Stream Generators

When tidal stream generators are looking to plan a new installation, first they use models made with data provided by NOAA (or the counterpart agency in that country) to narrow the search of potential sites. Once they identify potential sites the next step is to conduct a current and bathymetry survey on that area to determine the best locations for installation. This is where they could use our product to conduct current surveys for small scale tidal installations on developed waterways.

## 3.4 Competitors:

### 3.4.1 Acoustic Doppler Current Profiler (ADCP)

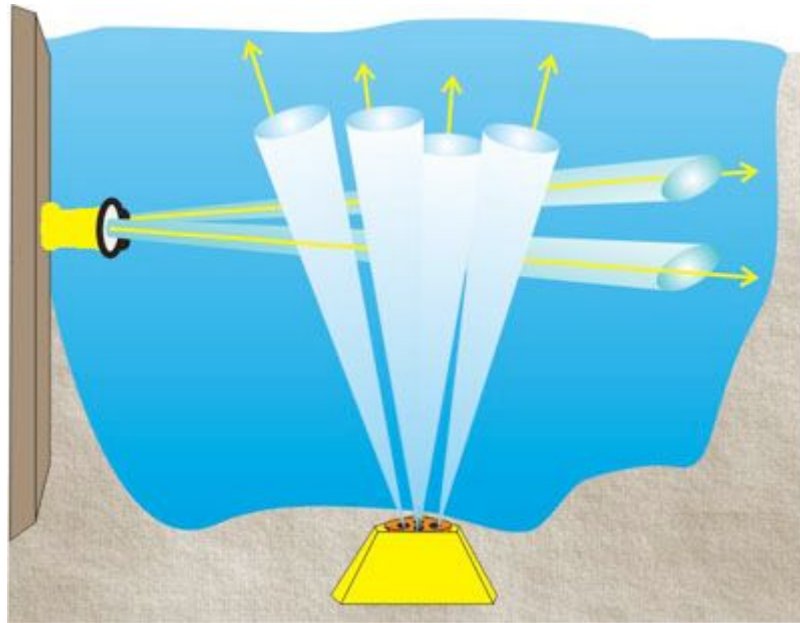

Figure 3.13 shows two ADCPS deployed in perpendicular to create a very accurate measurement of the current [19].

ADCPs are the most widely used current surveying tools on the market, first, will we go into how they work, then how they are used as well as their advantages and disadvantages compared to our product.

ADCPs contain a number piezoelectric transducers that transmit and receive sound signals. The traveling time of the sound wave gives an estimate of the distance, and the frequency shift of the echo is used to determine the velocity of the water. This is based off the Doppler effect that says the velocity of an object with respect to an observer will affect the frequency of a wave that object transmits [20]. Specifically, an object that is moving towards an observer will increase the frequency, and an object that is moving away will decrease the frequency. The most well-known example of this effect is the change in pitch that can be heard when a car with its horn on passes you. To provide a 3D measurement of a location's current an ADCP needs at least three transducers and the NOAA typically uses four.

When the NOAA conducts a current survey on a port or harbor, they typically deploy ADCPs from large research ships and leave them in development for at least 30 days to capture a full lunar cycle. They then use the data collected to build prediction models for current in that area. They are typically anchored to the bottom during these surveys but can also be mounted under large research ships to monitor continuously [21].

There are a few advantages to ADCPs. Firstly they contain no moving parts which makes them quite reliable being able to be deployed. Secondly, they provide a very accurate measurement of the current when appropriately used, however, the error grows towards the end of its range, meaning the surface current data for bottom mounted devices can be significant. The other main disadvantage is the cost, the cost for a small model intended for use in a river is upwards of \$20,000, and while the price of the models the NOAA uses is not available, it is safe to assume it is significantly higher than that.

#### 3.4.2 Shore-based Current Meters



Figure 3.14 This is an antenna that used High Frequency radio signals to measure the speed and direction of the surface current using the Doppler effect [22].

Shore-based Current Meters use High Frequency radio and radar to measure the surface speed and direction of the surface current close to shore. Just like ADCPs they also use the doppler effect to make this measurement. Using an array of two or more of these sensors researchers can create a map of thousands of points [23].

While this product is good at measuring surface current, it doesn't give insight into the subsurface current as the surface current is dominated by the force of the wind. This makes them not suitable surveying for tidal stream generation. The cost of installation can also be quite high as they need a fairly large amount of space, and infrastructure.

### 3.4.3 Shallow Water Drifter

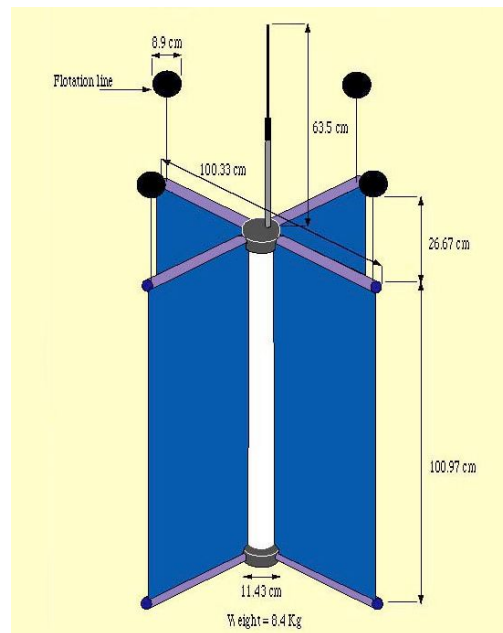

Figure 3.15 shows a diagram of a shallow water drifter, used to track near surface currents [24].

Shallow water drifters are used to track currents over wider ranges over the course of about a year. It uses the sails to catch the current then it drifts around following the current. The sails extend about 3ft into the water so it is not affected by the wind or waves. Its location is then sent up to a satellite. These are used to track and map ocean currents as they can drift over large areas and operate completely remotely [25]. They are not as suitable for tidal areas because there is a much higher chance they will get caught on something or wash up on shore.

### 3.4.4 Deep Ocean Drifter

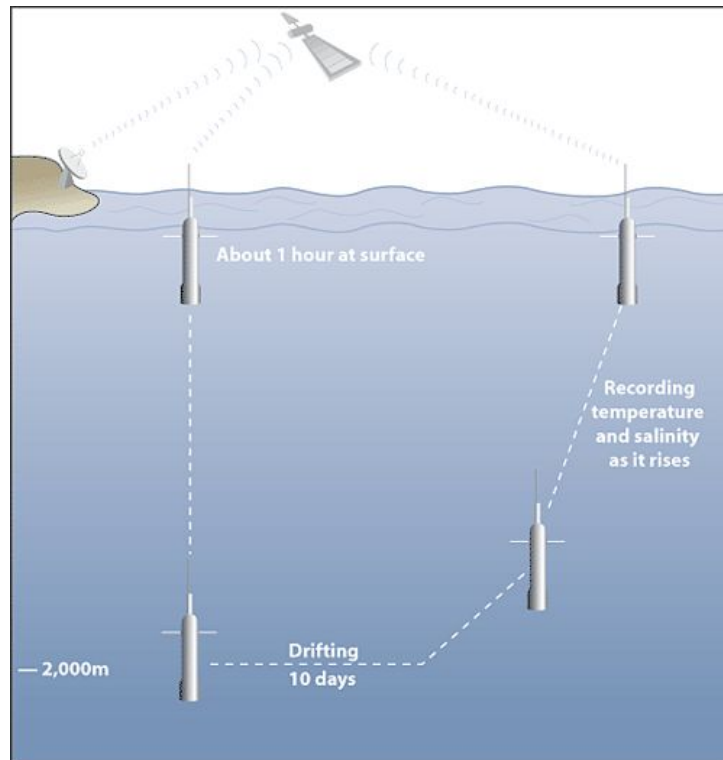

Figure 3.16 shows a Deep Ocean Drifter. This device is designed to sink down to a specific depth then track and record the current at that level by drifting. Then after the data capture period it automatically rises back to the surface to send its location back to shore via satellite [26].

Deep Ocean Drifters are ideal for studying deep sea ocean currents. They can sink down to 2,000m and have long deployment lives. They work in cycles of sinking, drifting, then rising over the course of about ten days. This then provides a data point about the current over the area it drifted. These devices last for about 150 cycles, so they are able to provide a lot of data over their life and it is completely remote [27]. However they are not suitable for tidal areas as they are not that deep and typically have many more obstructions than the open ocean.

# 4 Methodology

## 4.1 Design Objectives and Constraints

As this project developed we realized that it was necessary to change the objectives of our design. This was a result of a number of constraints and limitations we faced over the course of our research. The original objective was to design and build a self-powered remotely deploying current sensing device. During the course of designing that device we realized it was not going to be practical for us to build. Two major factors attributed to this, those being: The cost of a sonar modem for underwater communication, and the lack of mechanical engineering expertise to solve the many mechanical problems involved in the project. At that point we decided to split the project into two designs: A system level design for the electrical aspects of what we called the production design, that is the device that would actually be deployed in the ocean; and what we called a demo version that translated most of the main objectives of the production version into a design that we could practically construct a proof of concept from.

The following is the list of specific objectives and constraints that we used to construct both designs. In broad strokes the goal of the project was to create a small self-powered device that could be used to measure and wirelessly report the current data in real time.

### Objective 1: Self powered

This is one of the main objectives of the project because it is one of the major aspects separating it from its competitors. If the device were to be self-powered the deployment life would not be limited by energy storage. It is also one of the most innovative parts of the design as it is not seen in the market. As such this objective was addressed in both the production and demo versions of the design.

In order to have a long deployment life and remote sensing capabilities, the device should be able to power its data collection and communication by harvesting the current that it is measuring. This will provide some challenges for the design team because the power required to turn the propeller will change based on the load on the generator. This will

require either an adjustment to the recorded data based on the load and a charging circuit design that has a well-defined load. The total power system will be constituent of a battery, charging circuit, and the generator. The battery should be large enough to provide enough energy to transmit the data required even during slackwater when the generator is not producing power. The charging circuit should have good control over the load being placed on the generator. The generator should be geared and sized to maximize the power conversion from the propeller.

## Objective 2: Wireless Communication

Another key objective of the project was to be able to have the device remotely report the current data back to shore in real time. This would not be essential to all potential customers of the device, however it would be vital to other use cases and thus we decided to include it in the design. In the use case of surveying a micro-tidal energy installation, the device would likely be installed in a fixed location that is near shore infrastructure. That instance would likely not benefit from having real time access to the data because a customer would need at least one lunar tidal cycle (~28 days) of data in order to evaluate the viability of the site for tidal energy.

The other use case we considered is the device being used for real time current reporting to navigational agencies like NOAA. In this use case being able to wirelessly report the data being collected is essential and thus we decided to include this feature in our designs to appeal to the widest range of customers.

This objective is addressed in both the production and the demo versions of the design although in different ways due to the aforementioned expense of a sonar modem.

## Objective 3: Accurate Measurement

The ability to accurately measure the current at the location our device is deployed is vital to the overall goal of the project. This is one area where the competing projects are very good, the ADCP records very accurate data and this device should have a similar performance.

## Objective 4: Long Deployment Life

Another major product goal that we have is to ensure that our product has a long deployment life. By this, we mean that after our product is deployed, there should be minimal need for maintenance and the product should also work accurately for a year until the next maintenance schedule. We decided to make this a goal when we recognized the need for simpler and easy to manage models that can track data and can also be used for a long period of time. Only a product that is annually put under maintenance for inspections of different faults such as foul prevention will be suitable for use.

## Constraint 1: Less Expensive than Competing Products

Another goal that was important for our project was for our model to be less expensive than the Acoustic Doppler Current Profilers (ADCP) used by NOAA. Teledyne Marine has manufactured a variety of ADCPs and related parts for different purposes. They make the distinction between different bodies of water and different currents. They have different ADCPS for use in streams, lakes, rivers, as well as for open sea deployment. They are typically quite expensive costing over \$20,000 and to make our product viable we should be much cheaper than this. This would make it much cheaper to conduct surveys and allow for the deployment of more units in a survey.

Our product is focused on small to micro scale tidal energy installations and thus cost is a major factor if we wanted to be a viable option to that market. Also unlike the ADCP our device measures the current only at it's exact location, and therefore multiple devices would need to be deployed to survey the current in an area of interest.

## Constraint 2: GPS is not available

Because our device was planned to set in a certain position, there is no need to use GPS. It is also considered that, because our product is designed to use a small amount of energy, GPS will take much of the overall percentage of power consumption, which can significantly shorten its deployment cycle (at least a month). In addition to this, our design is intended to be deployed individually across a certain coastal region in order to accurately track the wave data along the coast. To do this, we also propose to have a station where the



tidal devices will be able to transmit data in real-time. By doing this, we eliminate the need to install a GPS device into our design.

### Constraint 3: Waterproof

Our device will be used in coastal areas of 10-20 metres depth in order to effectively track tidal stream data. In order to ensure that it accurately tracks data, we will apply water repellent coatings and also use the suitable waterproof shell on our design. Furthermore, the design will also include a circuit board for signal communication so it is critical to ensure that the design is waterproofed.

## 4.2 Electrical Design for Production Version

Based off the objectives and constraints discussed in Chapter 4.2 we constructed an electrical design for what we think a production version of the Tidal Energy Surveying Tool would have. This means a system of devices that could be deployed in the real world use cases previously described in this report. Please note this design is limited in scope to the electrical and system level aspects of the product, due to the lack of mechanical engineering expertise of the design team. The key mechanical features that would have to be designed for the product to be produced are a waterproof enclosure with necessary sealing and a propeller designed to work efficiently at the low flow velocities (0-3m/s).

Our designs consist of a detailed block diagram showing all subsystems and the connections and a set of specifications detailing the requirements of those subsystems and connections. Figure 4.1 is the detailed block diagram and it's detailed specifications are attached in Addendum C. Note a larger full page version is attached in Appendix A in case the details of Figure 4.1 are not clear on your viewing medium.

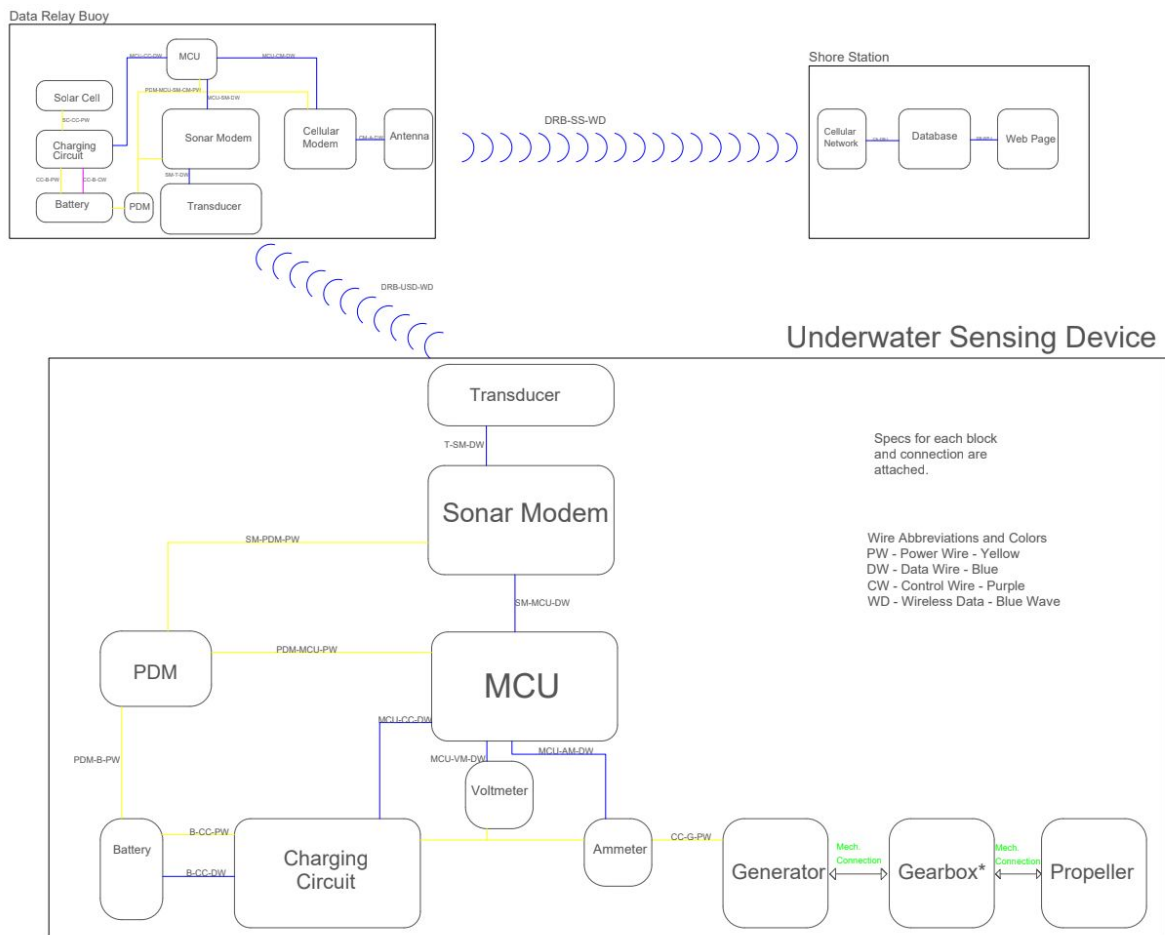

Figure 4.1: Detailed Block Diagram of Production Device Design

The first thing to notice about the design is that it is comprised of three individual physical devices: The Underwater Sensing Device, the Data Relay Buoy, and the Shore Station. These devices will be discussed in more detail in the following sections but first we would like to discuss the overall architecture of the system.

The product was broken up into three separate devices to allow the most flexibility based on our customers needs. The primary use case for the system is a deployment in high traffic areas like bays, harbors, and inlets, due to this we wanted to keep the surface obstructs, and wires to the surface to a minimum. Both of these can impair nautical navigation and would thus be less appealing to our customers. This is why we decided to implement what we call a data relay buoy. The buoy would float atop the water and bridge the communications between the data collection and the end user. The buoy would be able to service many underwater sensing devices in a ~3km radius and then send that data back to

the shore. This approach is already used in industry for communication with remotely operated underwater vehicles.

The communication between devices is another important aspect of the design. First let's look at the communication between the underwater sensing device and the data relay buoy. Saltwater is conductive and blocks almost all electromagnetic wave based communication<sup>1</sup> and as such SONAR is the the only means of wireless underwater communication. SONAR uses sound waves to propagate longitudinal waves through the water. It was originally created to find the depth of water a ship was navigating in by tracking the time it takes for a wave to reflect of the seafloor and travel back up to the transducer. Recently it has been adapted for use in communication by sending packets of data to other transducers. For the communication between the data relay buoy and the shore station we had many more options. The one we decided on is cellular GSM communication due to its availability and ease of use. Because we are focusing on near shore applications there will likely be cellular coverage in the deployment areas. The real advantage of using GSM over other means of wireless communication available is that it allows for the buoy to directly connect to the internet. If we used a radio based communication system we would need to have an additional receiver station on shore that would then upload the data to our end users.

#### 4.2.1 Underwater Sensing Device

The overall idea for the underwater sensing device is a device that sits underwater, records the current at its location, sends that current data to the data relay buoy, and powers itself. Figure 4.2 is the block diagram for the underwater sensing device, which is zoomed in from Figure 4.1. We will now go over each block of the system.

---

<sup>1</sup> The exception here is Extremely Low Frequency (ELF) which frequencies between 3 and 30 Hz which can penetrate saltwater. They are used to communicate with nuclear submarines. Due to the extremely long wavelength >100,000 km the Earth itself is used an antenna. [28]

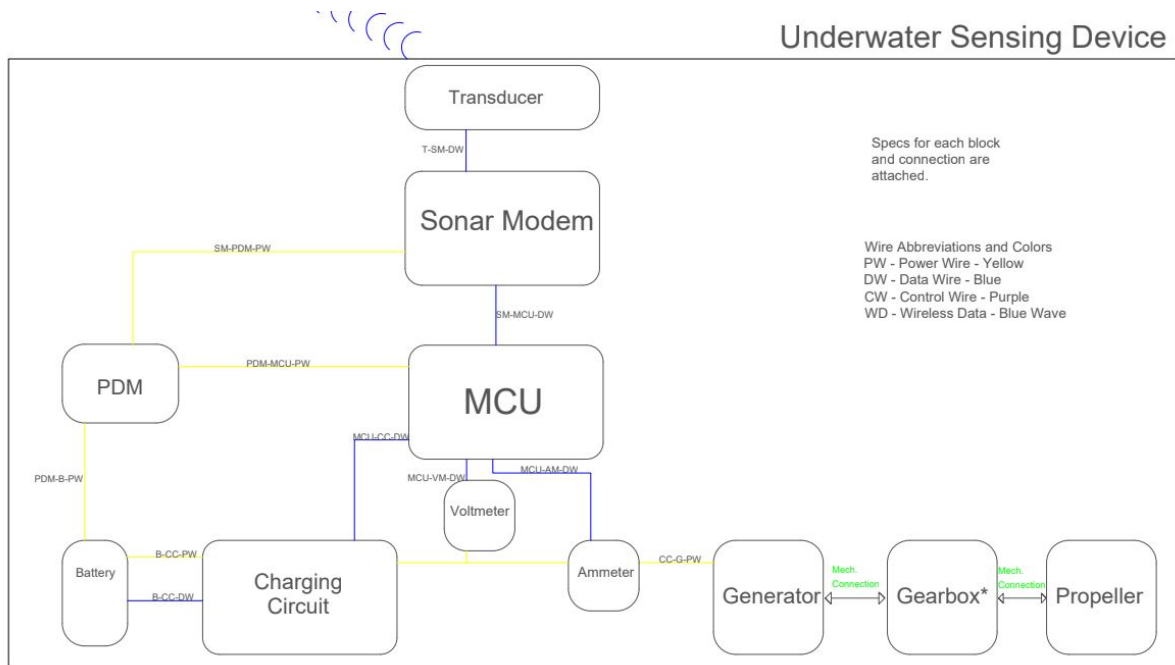

Figure 4.2: Block Diagram of Underwater Sensing Device

The generator, gearbox, and propeller would provide the power and measurement input to the device. The propeller would need to be designed with a pitch and diameter that would provide enough power to the device to make the transmissions and limit the slippage of the propeller rotation and the current passing over it. The gearbox is there to increase the rotational speed of the propeller shaft to speed required for the generator to operate efficiently. The generator would convert the mechanical energy of the spinning propeller to electrical energy that would power the device.

The energy produced by the generator is how the device would measure the current.

$$P = \frac{1}{2}\rho\eta AV^3 \quad (1)$$

Where  $P$  = Power,  $\rho$  = The density of water  $997 \text{ kg/m}^3$ ,  $\eta$  = Efficiency of the propeller,  $A$  = Rotor sweep area of the propeller, and  $V$  = Flow velocity of the current. Equation 1 was key in the design of the underwater sensing device because it determines how much power the current could produce to power the device and it let us calculate the current passing over the propeller based on the power we calculated from the measurement part of the device.

The measurement components of the device are the voltmeter and the ammeter; from that we can calculate the power produced by the generator and then using Equation 1, the

flow velocity of the current. Testing would have to be done using a known flow velocity to calibrate the efficiency of the propeller.

The next major subsystems are the battery charging circuit, the battery, and the power distribution module (PDM), all these work together to power the device. The battery needs to be large enough to power the MCU and sonar modem during the slackwater periods of the time because the current will be low or zero the generator will not be producing energy. We calculated the approximate device power usage to be an average of 27 mW based on a 10 minute transmission period, meaning we send a transmission every 10 minutes. We chose lithium as the battery chemistry as it is the industry standard for devices of this type. The charging circuit, monitors the battery voltage and temperature and ensures the battery is charging safely. The PDM converts the battery voltage to the 5V required for the MCU and the 6/12V required for the SONAR modem.

The last two subsystems are the MCU and SONAR modem and transducer. The MCU records and stores the measurements taken by the voltmeter and ammeter and then passes them to the SONAR modem. The SONAR modem then converts the data from the MCU into the protocol that is transmitted from the transducer. The design was based around the DSPComm Aquacommodem which allows for SONAR networking and uses very low power.

#### 4.2.2 Data Relay Buoy

As described before the data relay buoy acts as a communication bridge between the underwater sensing device and the end user. It receives the SONAR communication from the underwater sensing device using a DSPComm Aquatrans modem, and then transmits that data to shore using the cellular GSM protocol. Figure 4.3 shows the zoomed in block diagram of the Data Relay Buoy.

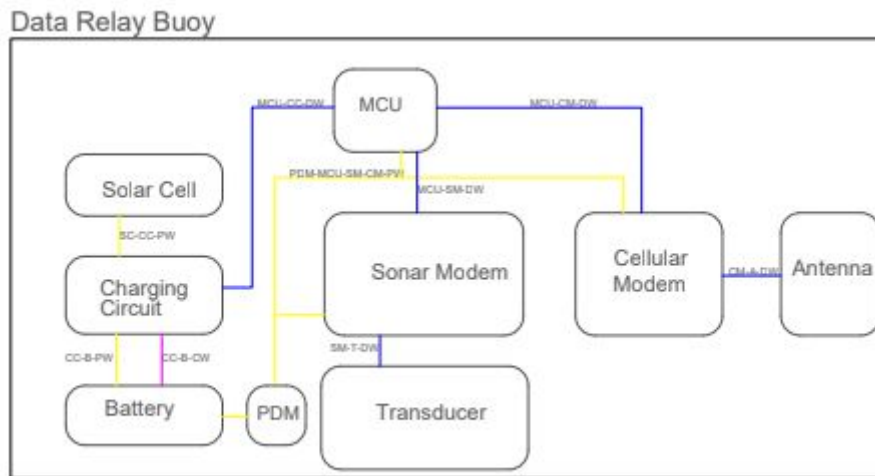

Figure 4.3: Block Diagram of Data Relay Buoy

The subsystem for powering the device is similar to the underwater sensing device with the replacement of a solar cell rather than the propeller generator. Solar cells are currently used in industry for powering buoys. The charging circuit performs the same function as in the underwater sensing device, safely charging and monitoring the battery. The battery needs to be big enough to power the buoy overnight and during periods with no sun. To accomplish this we chose an 18650 cell package which has a large capacity. The PDM provides the proper voltage to the MCU, Sonar Modem, and Cellular modem. Lastly the MCU receives the data from the Sonar modem and converts it into a form that can be read by the cellular modem. Figure 4.4 shows an example of the SONAR networking from the modem manufacturer DSPComm.

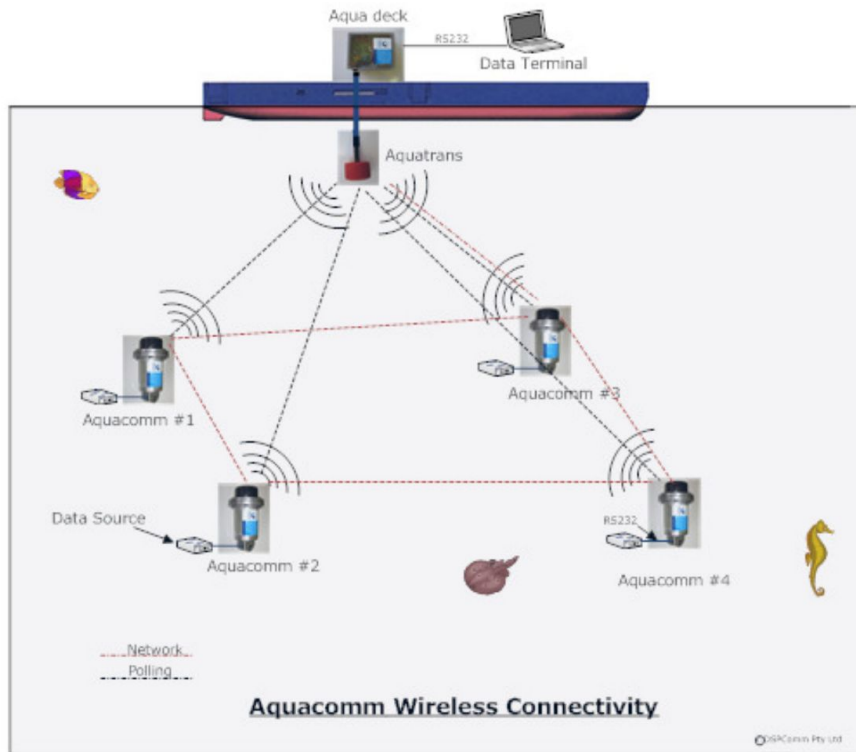

Figure 4.4: Example of an underwater SONAR network from DSPComm [29].

### 4.2.3 Shore Station

By using the cellular network on the data relay buoy the Shore Station has become a virtual location rather than a physical one. The data relay buoy can use the GSM protocol to directly establish a TCP connection to the end users database server. For our design we assumed this would be a SQL based database as they are typically used in applications of this size. Once the current data is on the database the end user can perform any necessary calculations or analysis on it. The calculations to transform the current power data measured by the underwater sensing device will take place on the database server to keep the energy usage of the field devices to a minimum. So the underwater sensing device will only be transmits the measured data and its unique identifier. That unique identifier will be associated with the sensing devices deployment location on the server.

## 4.3 Proof Of Concept

After designing the system described in Chapter 4.2 we wanted to build a working prototype to demonstrate the system's viability, however we soon realized that was impractical for this design team. The two main factors that made this impractical were: That the cost of the DSPComm SONAR modem or similar models exceeded the budget for the entire project, and there was extensive mechanical designs that had to be done. These mechanical designs were mainly around the propeller. The propeller would have to be specially designed to work in low speeds and no existing products on the market are targeted in this area. The propeller shaft would also require sealing to prevent the ingress of seawater into the electrical components. This would require a specially designed seal and housing. This design team lacked the expertise in those areas to complete the design. Still wanting to build some proof of concept we decided to focus on the electrical aspects of the underwater sensing device, while preserving as much of the original design concept as possible.

This chapter will discuss the new design we devised for a proof of concept device, but first we will go over the major conceptual changes to the design. As SONAR is the only means of underwater communication and that was unavailable for the proof of concept, the proof of concept device can not be fully submerged in water. The next conceptual change is with the mechanical design, we found an off the shelf micro-hydro generator that integrates the propeller, gearbox, and generator into one unit. This also allows us to easily test the device because we can now connect a pump to the generator to be able to test know flow velocities.

### 4.3.1 Block Diagram

The block diagram for the proof of concept device is shown in Figure 4.5. The major differences are in the method of communication and the omission of the data relay buoy. The SONAR communication was replaced with a Wifi module. The module is based off the Espressif ESP8266, which is a low cost, low power wifi microchip. The rest of the block diagram is similar to the production version described in Chapter 4.2 so we will explain the details of the system based on the schematic in the next chapter.



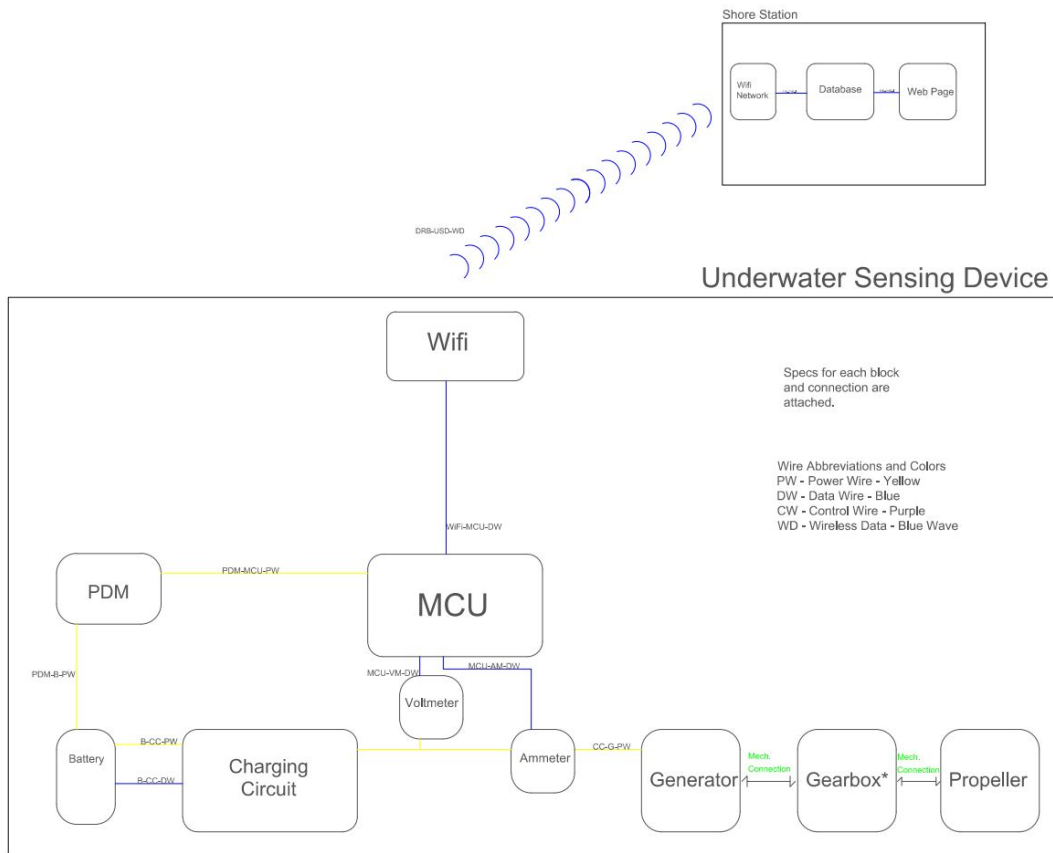

Figure 4.5: Proof of Concept Block Diagram

### 4.3.2 Circuit Schematic

Figure 4.6 shows the circuit schematic generated from the block diagram in Figure 4.5. It features all the features shown in the block diagram with the exception of the ESP-01 Wifi module, because no circuit footprint was available. The connection is shown in the header connection JP1. EAGLE was used to design the circuit schematic and later the PCB. A full page version will be attached in Appendix D in case the schematic is not clear in your viewer medium.

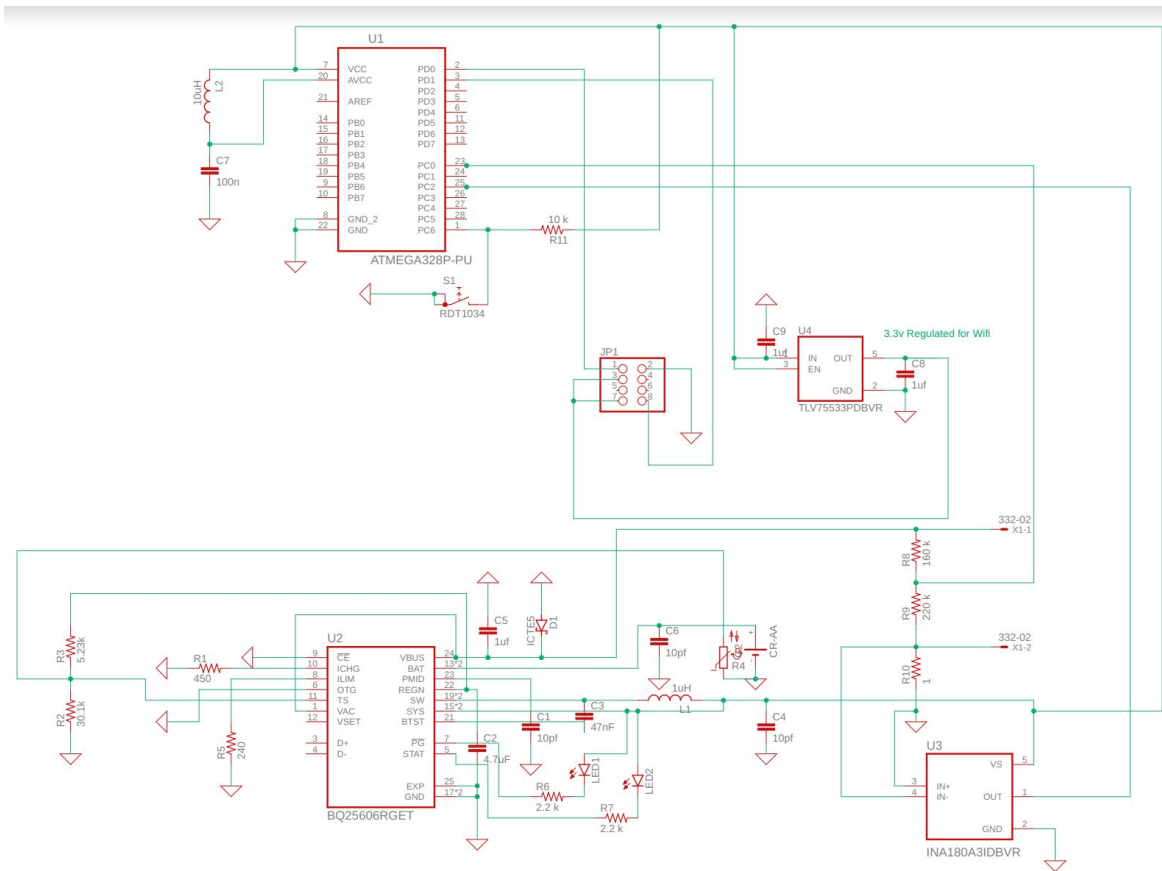

Figure 4.6: Proof of Concept Circuit Schematic

Starting with the device input X1-1 and X1-2, these are the connectors that connect the device board to the generator unit. X1-1 is the positive rail and X1-2 the negative. We expect between 3-12V with a maximum of 3.5W input from the generator based on its specifications. That is directly connected to the measurement system for the device. A voltage divider, R8 and R9, across the rails scales the maximum 12V down to 5V required for the ADC on the MCU. Equation 2 gives the equation for a voltage divider:

$$V_{out} = \frac{R_2}{R_1 + R_2} V_{in} \quad (2)$$

where  $V_{in}$  is the voltage from the generator,  $R_1$  is R8,  $R_2$  is R9, and  $V_{out}$  is the voltage going to the ADC. We know  $V_{in} = 12V$  and  $V_{out} = 5V$  and then we can pick a commonly available resistor value for  $R_2$  of 160K and then using Equation 2 find that  $R_1 = 220K$ .

Below the voltage divider R10 is a shunt resistor, between the negative rail of the generator and the circuit ground. Using the INA180A3IDBVR Op-Amp chip we can amplify the voltage drop across the resistor to range from 0-5V so it can be measured by the ADC on

our MCU. The INA180 chip is a lowside voltage output, current sense op amp. We expect the maximum current draw to be around 47 mA during transmissions which using Equation 3, Ohm's Law, and the 1Ω value for R10 would be a 47mV potential drop. The voltage gain of the amplifier is 100 V/V which means there will means it will have a range of 0-4.7V.

$$V = IR \quad (3)$$

From that we can calculate the power entering the device by Equation 4.

$$P = IV \quad (4)$$

The MCU that was chosen was the Atmel ATMEGA328P. This is the same microcontroller used in the Arduino UNO development boards. This let us use the Arduino IDE which simplified programming the chip. It's programming will be detailed in Section 4.3.3.

A lithium ion battery was picked to provide energy storage for the device. This is the same as the production version. To charge the battery we picked the TI BQ25606RGET integrated battery charger and monitor. This chip was picked over other lithium battery monitor/chargers because it has a very wide range of available input voltages, 3.9 to 13.5. Other chips considered were the Maxel MAX8900 and the On Semiconductor FAN5400 but there input voltage range was too small in the case of the MAX8900, or the minimum voltage was too high in the case of the FAN5400. This was important to the design because the generator voltage can vary widely based on the flow rate of the water and we wants as wide a usable range as possible. All the circuitry around the BQ chip were designed in accordance with the manufacturers recommendations.

Lastly the TLV75533 chip is a voltage regulator to convert the 4.2V produced by the charging circuit to the 3.3V required for the ESP-01 Wifi module.

This schematic was then implemented into a PCB layout and printed, that will be detailed in Chapter 5.

### 4.3.3 Microcontroller Programming

Using the results from Section 6.1 and the equations described in Section 4.3.2 and Section 5.2 we can program the microcontroller to calculate the flow velocity. The full code will be attached in Appendix E and described here. We used the Arduino IDE to program the ATMEGA328P, which uses a slightly modified version of the C++ programming language.

The first thing we need to do is read the signal from the voltage divider and current sensing Op-Amp using the “analogRead()” read function. This function maps the 0-5V signal input the the chips ADC to an integer between 0 and 1023. To convert back to the voltage being read off the ADC we multiply both values by (5.0/1024).

To find the voltage across the generator input we use Equation 2 and the R8 and R9 resistor values. To find the current first we divide the voltage by the Op-Amp amplification factor of 100V/V and then use Equation 3 and the R10 resistor value to find the current entering the device. From there we use Equation 4 to find the power being produced by the generator.

Now that the power is calculated we use Equation 8, determined in Chapter 6.1 to calculate the flow velocity. This measurement program is performed every ten seconds.

To send the data collected by the device to the end user, it uses the ESP-01 Wifi module to connect to a Wifi network. Because of how the database is set up (discussed in the next section) the microcontroller only needs to make a simple HTTP GET request to upload the data.

#### 4.3.4 SQL Database Set-up

Now that we have the measurements being recorded on the microcontroller we need to have somewhere to send them, for this we chose a MySQL database. MySQL is a powerful open-source database management software. For our purposes it allows us to remotely store, access, manipulate, and organize the velocity data from our tests. To set-up the MySQL database we used a software called XAMPP. This software integrates the MySQL database (also known as MariaDB), an Apache HTTP web server, and a PHP interpreter among other things. This makes it very easy to connect the microcontroller to the database using HTTP requests. Efficiently what it makes is that the data can be stored by going to a specific web address. Specially the microcontroller connects to an IP address and port that is hosting the web server and execute a PHP script that adds the data to the database. To give an example:

“http://127.0.0.1/write\_data.php?value=2.2”

127.0.0.1 refers to the server address that the database is running on, in this example that is the address for a local machine. “write\_data.php” is a PHP script that establishes a connection to the MySQL database and uploads the velocity data “value” which would be a

floating point number. The code for this script can be found in Appendix F. The MySQL table is set up with three columns, a unique identifier , the time and data that the entry was made, and the velocity being stored. By storing the time and velocity together we can create at history for the current at that devices location. Figure 4.7 shows an example of what the database looks like when viewed through the phpMyAdmin administrative viewing tool, the data can also be accessed programmatically.

UID	Time	Velocity
8	2019-04-24 22:14:53	0.999391
9	2019-04-24 22:14:54	0.99863
10	2019-04-24 22:14:55	0.997564
11	2019-04-24 22:14:56	0.996195
12	2019-04-24 22:14:57	0.994522
13	2019-04-24 22:14:58	0.992546
14	2019-04-24 22:14:59	0.990268
15	2019-04-24 22:15:01	0.987688
16	2019-04-24 22:15:02	0.984808
17	2019-04-24 22:15:03	0.981627
18	2019-04-24 22:15:04	0.978148

Figure 4.7 Example of Data Storage in MySQL Database

## 5 Implementation and Testing

### 5.1 PCB Layout

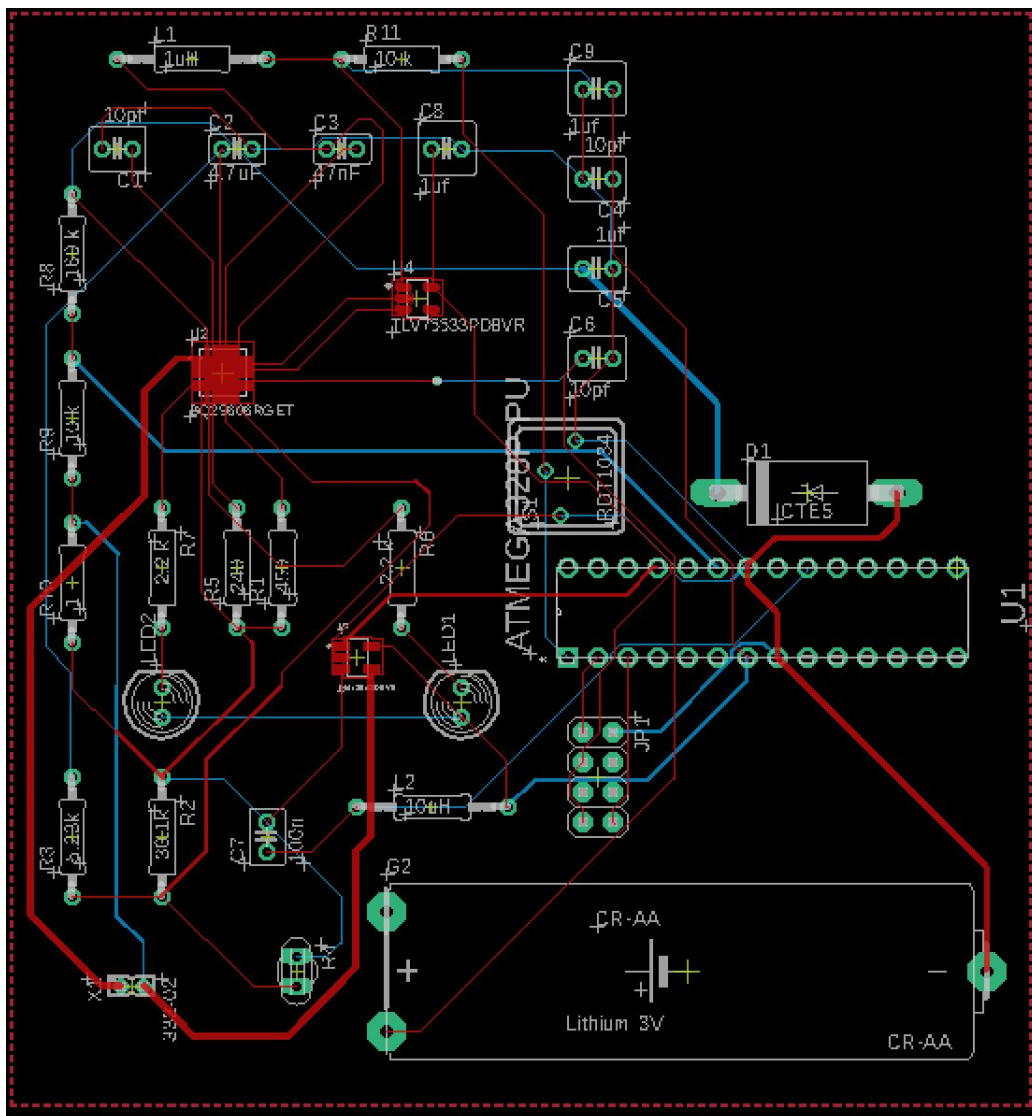

Figure 5.1: Proof of Concept PCB Layout

Based on the schematics, a PCB layout was designed in order to make the proof of concept. A lot of space is left around the BQ25606RGET chip, because it has a very tight surface mount package that can be hard for manual soldering. Unfortunately most ICs being produced have very small surface mount packages that make prototyping difficult. The thermistor R4 was aligned near the battery for better battery temperature monitoring. After

all the parts were placed with consideration for the IC manufacturer recommendations, the parts were connected using to flywires given by the software; ground plane was also added to both sides. A large area at the upper right is left blank, as designers can print logos on the solder mask.

## 5.2 Testing Apparatus

Figure 5.2 shows the apparatus we used for testing the measurement and generation features of the device. It consists of a Bilge pump connected to the generator via  $\frac{3}{4}$  inch vinyl tubing and PVC piping, which sits in a plastic tube that is filled with water. The blue PVC pipe and generator can also be connected to a  $\frac{3}{4}$  inch hose for testing.

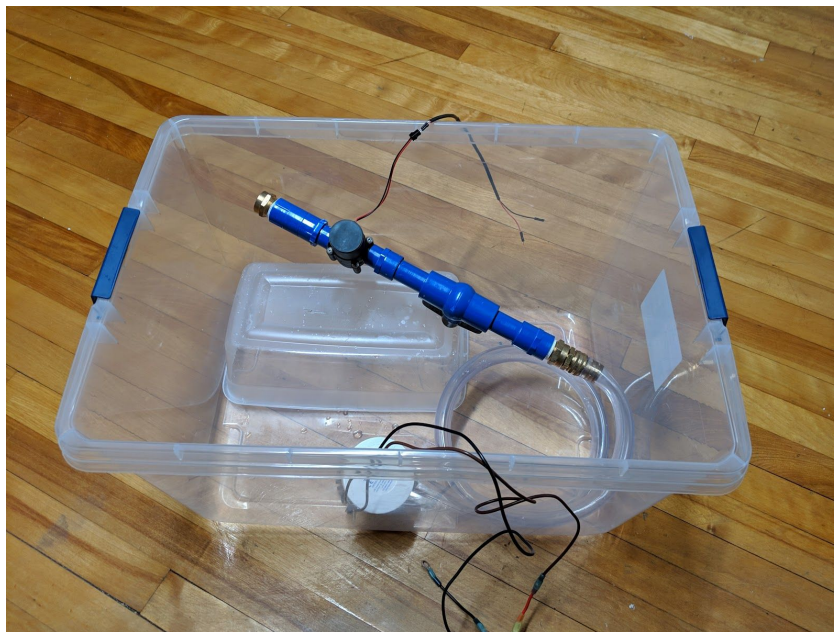

Figure 5.2: Proof of Concept Testing Apparatus

To test the idea of calculating the flow velocity based on the power generated by the generator, we devised a test. We purchased two bilge pumps each with a different flow rate rating and ran them at 12V and 12.6V so they each produced different flow rates. The flow rates were measured by timing how long it took to fill up a .5 liter measuring cup. The power being generated was determined by measuring the voltage across a  $50\Omega$  resistor and using Equation 5. We can use this equation here because it is a constant resistive load, in the proof of concept device we need to measure both the voltage and current because the load may not be constant.

$$P = \frac{V^2}{R} \quad (5)$$

That gave us 4 data points we that we can use to interpolate the flow velocity for any power within the measurement range. The results of that test are presented in Chapter 6.

We now need to make a quick digression about fluids flowing through pipes. Because we are measuring the flow through a pipe Equation 1, that would be used for the production device, does not work. The first equation we need is that for the power generated by the pump and is given by Equation 6, where  $P$  is power,  $p$  is pressure, and  $Q$  is the volumetric flow rate.

$$P = pQ \quad (6)$$

The pressure in all tests can be assumed to be constant because the pressure is a function of the restrictions in the pipes and the height of the outlet, which were kept constant for all tests. So the volumetric flow rate is directly proportional to the power generated by the pump. From there we can use Equation 7 for volumetric flow rate in a pipe to find flow velocity of the water in the pipe.

$$Q = \frac{v}{A} \quad (7)$$

where  $Q$  = volumetric flow rate,  $v$  = flow velocity, and  $A$  = the cross-sectional area of the pipe. Please note that while the flow velocity will vary based on the cross-sectional area of the pipe the volumetric flow rate is the same throughout the system.



# 6 Results

## 6.1 Measurement Test Results

Following the testing procedure described in Chapter 5.2 we conducted a test to measure the accuracy of the measurement concept of our design. We conducted 5 trials at each flow rate and averaged the powers and measured flows together. Table 6.1 shows those results and Figure 6.1 illustrates that data.

Table 6.1 Flow Velocity vs Power Measurement

Velocity(m/s)	Flowrate(LPH)	Power(W)
0.1568930595	160.9722791	0.03115546559
0.1780571449	182.6866307	0.06795870445
0.2045303531	209.8481423	0.07469392713
0.2400822915	246.3244311	0.1314291498

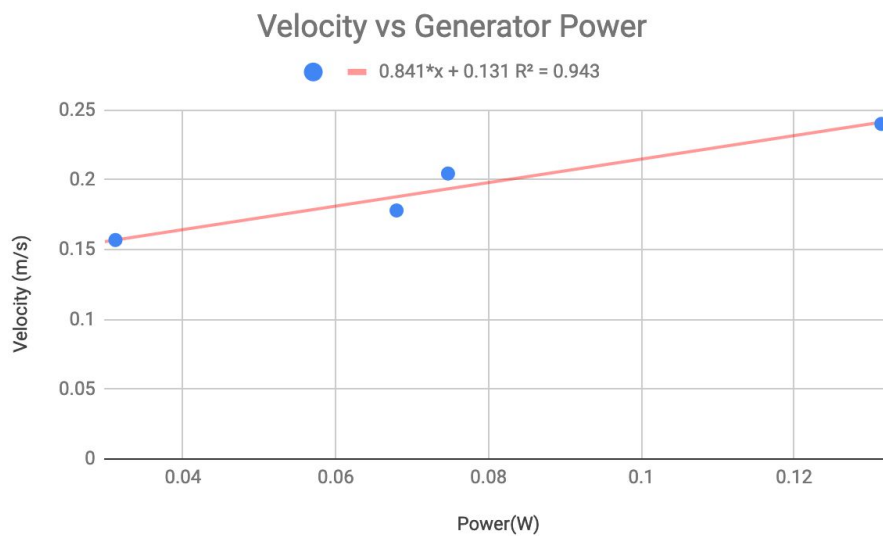

Figure 6.1: Velocity vs Generator Power scatter chart

We know there is a linear relationship so we can fit a line over the points with Equation .

$$v = .841 * P + .131 \tag{8}$$

Even though the coefficient of determination is fairly good ( $R^2 = 0.943$ ) this data is of limited use. There is simply not enough data to be able to extrapolate this line beyond the original data which means we can only measure a range of less than .1 m/s rather than the 3 m/s range we need to be useful. The reason the sample size is limited is due to the difficulty of creating different flow rates. The flow rate depends solely on the pump producing the flow and as we only had two pumps that limited our ability to collect data. We recommend using a dedicated flow velocity sensor in future iterations of this project.

## 6.2 PCB Testing Results

Unfortunately we must end this report anticlimactically, because the PCB did not work, and so we were unable to test its functionally. However disappointing that is there is still valuable information in discussing why it did not work. Figure 6.2 shows the fatal issue, the net leaving X1-1 (the right port on the X1 connector) should not have been set to net 0. Net 0 is the ground reference net for the circuit and during the schematic design it appears that the net leaving X1-1 was inadvertently set to net 0 which caused it to be connected to every ground on the PCB.

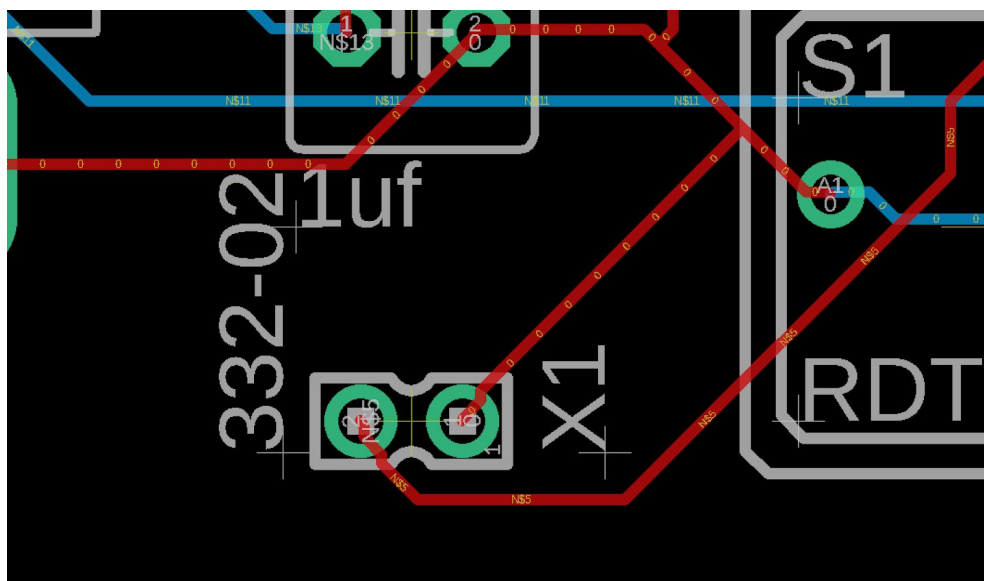

Figure 6.2: Fatal Error on PCB Layout

This error was not caught during the schematic design because the schematic appears correct, there is no visible connection between the X1-1 net and ground. Also EAGLE, the software used to design the schematic and PCB does not display the net name unless the net

is individually inspected. The error was also not caught during the PCB design and layout. It was only realized upon testing the board. The mistake was quickly fixed by deleting the net and replacing it, however at that point there was insufficient time to re-spin a new board, populate it, and test it. The fixed PCB layout was shown in Figure 5.1, however it is untested.

## 7 Conclusion and Future Works

The overall goal of our project was to demonstrate our original concept and design a device that fulfills a particular need in the tidal energy space. While we were unable to demonstrate our proof of concept, we still had our production design as a potential need for the new energy market. As a result of this project, we are interested in seeing how the tidal energy space can develop and advance in order to utilize it as a reliable source of renewable energy.

Our device is a replacement for the needs of tidal current studies and the use of prediction models for current data; our devices can be deployed for a long period while providing real-time current data in a broad area, which makes it much easier and affordable to determine potential sites for smaller-scale tidal stream energy installations.

Ultimately, there are still a number of areas where we could have improved the project. For our testing apparatus, instead of measuring the power generated from the turbine to determine the flow velocity of water, it would have been much more appropriate to include a speed sensor. A dedicated propeller design, as well as, a gearbox are also desired from mechanical engineers. Specifically, we are also interested in the development of an open-source SONAR communication protocol so that sonar devices could become cheaper and more accessible.

## References

- [1] "In 2018, the United States consumed more energy than ever before", *Today in Energy*, 2018. [Online]. Available: <https://www.eia.gov/todayinenergy/detail.php?id=39092>. [Accessed: Apr- 2019].
- [2] "Wave & Tidal Energy - RenewableUK", *Renewableuk.com*. [Online]. Available: <https://www.renewableuk.com/page/WaveTidalEnergy>. [Accessed: Apr- 2019].
- [3] "NOAA Tides & Currents", *Tidesandcurrents.noaa.gov*. [Online]. Available: <https://tidesandcurrents.noaa.gov/constitu.html>. [Accessed: Apr- 2019].
- [4] E. Wolanski and M. Elliott, "Estuarine water circulation", *Estuarine Ecohydrology*, pp. 35-76, 2016. Available: 10.1016/b978-0-444-63398-9.00002-7 [Accessed April 2019].
- [5] "Types and Causes of Tidal Cycles - Tides and Water Levels: NOAA's National Ocean Service Education", *Oceanservice.noaa.gov*, 2019. [Online]. Available: [https://oceanservice.noaa.gov/education/tutorial\\_tides/tides07\\_cycles.html](https://oceanservice.noaa.gov/education/tutorial_tides/tides07_cycles.html).
- [6] "How do we monitor currents?", *Oceanservice.noaa.gov*. [Online]. Available: <https://oceanservice.noaa.gov/facts/currentmon.html>. [Accessed: 24- Apr- 2019].
- [7] M. Ryckaert, *Olhão (Algarve, Portugal), Natural Park Ria Formosa: the tide mill*. 2007.
- [8] "Tidal Barrage and Tidal Barrage Energy Devices", *Alternative Energy Tutorials*, 2019. [Online]. Available: <http://www.alternative-energy-tutorials.com/tidal-energy/tidal-barrage.html>.
- [9] Wales News Service, *Artist's impression of the Swansea Tidal lagoon*.
- [10] "Tidal Power", *EDF France*, 2019. [Online]. Available: <https://www.edf.fr/en/the-edf-group/industrial-provider/renewable-energies/marine-energy/tidal-power>.
- [11] Wikimedia, *Maquette de la coupe du barrage de la Rance*. 2002.
- [12] Tswgb, *Aerial view of the tidal barrage on the Rance and of Saint Malo*. 2007.

- [13] MyGen, *Tidal Energy Project Pentland Firth*. 2007.
- [14] "Tidal developers", *Emec.org.uk*, 2019. [Online]. Available: <http://www.emec.org.uk/marine-energy/tidal-developers/>. [Accessed: Apr- 2019].
- [15] Ocean Renewable Power Company (ORPC), *ORPC's TidGen® Power System prior to installation in Cobscook Bay, Maine*. 2012.
- [16] "Marine Power Project :: Oscillating Hydrofoil", *Esru.strath.ac.uk*, 2019. [Online]. Available: [http://www.esru.strath.ac.uk/EandE/Web\\_sites/05-06/marine\\_renewables/technology/oshydro.htm](http://www.esru.strath.ac.uk/EandE/Web_sites/05-06/marine_renewables/technology/oshydro.htm). [Accessed: Apr- 2019].
- [17] Minesto, *Deep Green Tidal Kite*. 2013.
- [18] A. Roberts, B. Thomas, P. Sewell, Z. Khan, S. Balmain and J. Gillman, "Current tidal power technologies and their suitability for applications in coastal and marine areas", *Journal of Ocean Engineering and Marine Energy*, vol. 2, no. 2, pp. 227-245, 2016. Available: 10.1007/s40722-016-0044-8 [Accessed April 2019].
- [19] NOAA Ocean Education, *Two ADCPs deployed in a waterway*.
- [20] "Acoustic Doppler Current Profiler (ADCP)", *Woods Hole Oceanographic Institution*, 2019. [Online]. Available: <https://www.whoi.edu/page.do?pid=8415&tid=282&cid=819>. [Accessed: Apr- 2019].
- [21] "NOAA's National Ocean Service Education: Currents: ADCP, Acoustic Doppler Current Profiler", *Oceanservice.noaa.gov*, 2019. [Online]. Available: <https://oceanservice.noaa.gov/education/kits/currents/07measure5.html>. [Accessed: Apr- 2019].
- [22] NOAA Ocean Education, *Shore-based Current Meters*.
- [23] "NOAA's National Ocean Service Education: Currents: Shore-based Current Meters", *Oceanservice.noaa.gov*, 2019. [Online]. Available: <https://oceanservice.noaa.gov/education/kits/currents/07measure6.html>. [Accessed: Apr- 2019].

- [24] NOAA Ocean Education, *Shallow Water Davis Drifter Schematic*.
- [25] "Currents: How Are Currents Measured?: Shallow Water Drifter", *Oceanservice.noaa.gov*, 2019. [Online]. Available: <https://oceanservice.noaa.gov/education/kits/currents/07measure3.html>. [Accessed: Apr- 2019].
- [26] NOAA Ocean Education, *Deep Ocean Drifter*.
- [27] "Currents: How Are Currents Measured?: Deep Ocean Drifter", *Oceanservice.noaa.gov*, 2019. [Online]. Available: <https://oceanservice.noaa.gov/education/kits/currents/07measure4.html>. [Accessed: 24- Apr- 2019].
- [28] S. L. Bernstein *et al.*, "Long-range communications at extremely low frequencies," in *Proceedings of the IEEE*, vol. 62, no. 3, pp. 292-312, March 1974.  
doi: 10.1109/PROC.1974.9426
- [29] DSPComm, *Aquacom Wireless Connectivity*. 2018.

## Appendix A: Large Form Production Version Block Diagram

[This page is intentionally blank the next page contains the block diagram]



### Data Relay Buoy

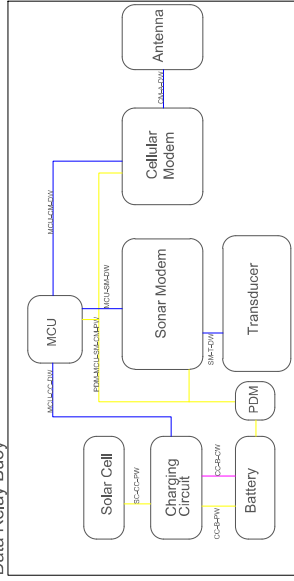

### Shore Station

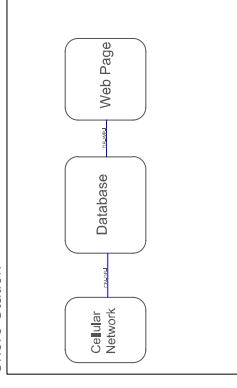

DRB-SS-WD



DRB-IJSD-WD

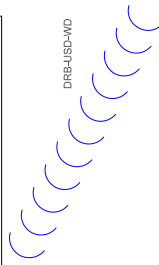

## Underwater Sensing Device

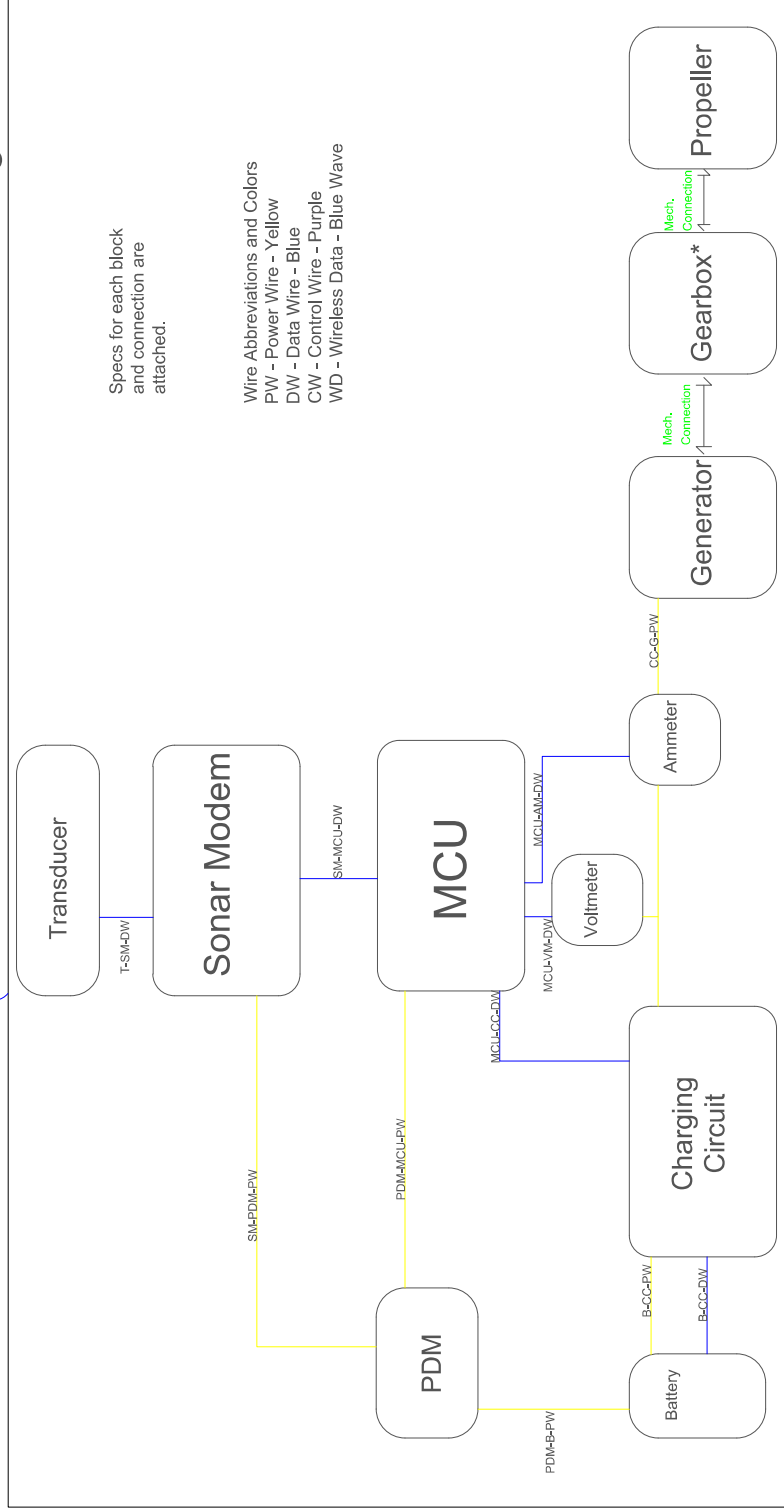

## Appendix B: Large Form Proof of Concept Block Diagram

[This page is intentionally blank the next page contains the block diagram]

Shore Station

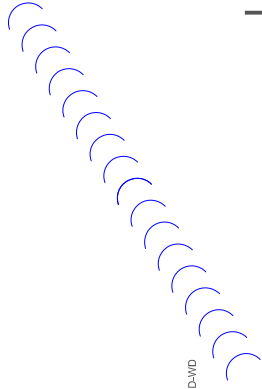
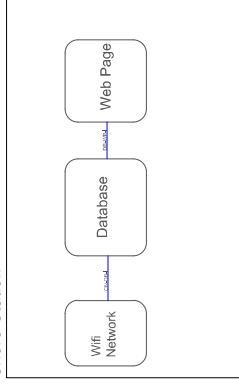

DRB-USD-WD

# Underwater Sensing Device

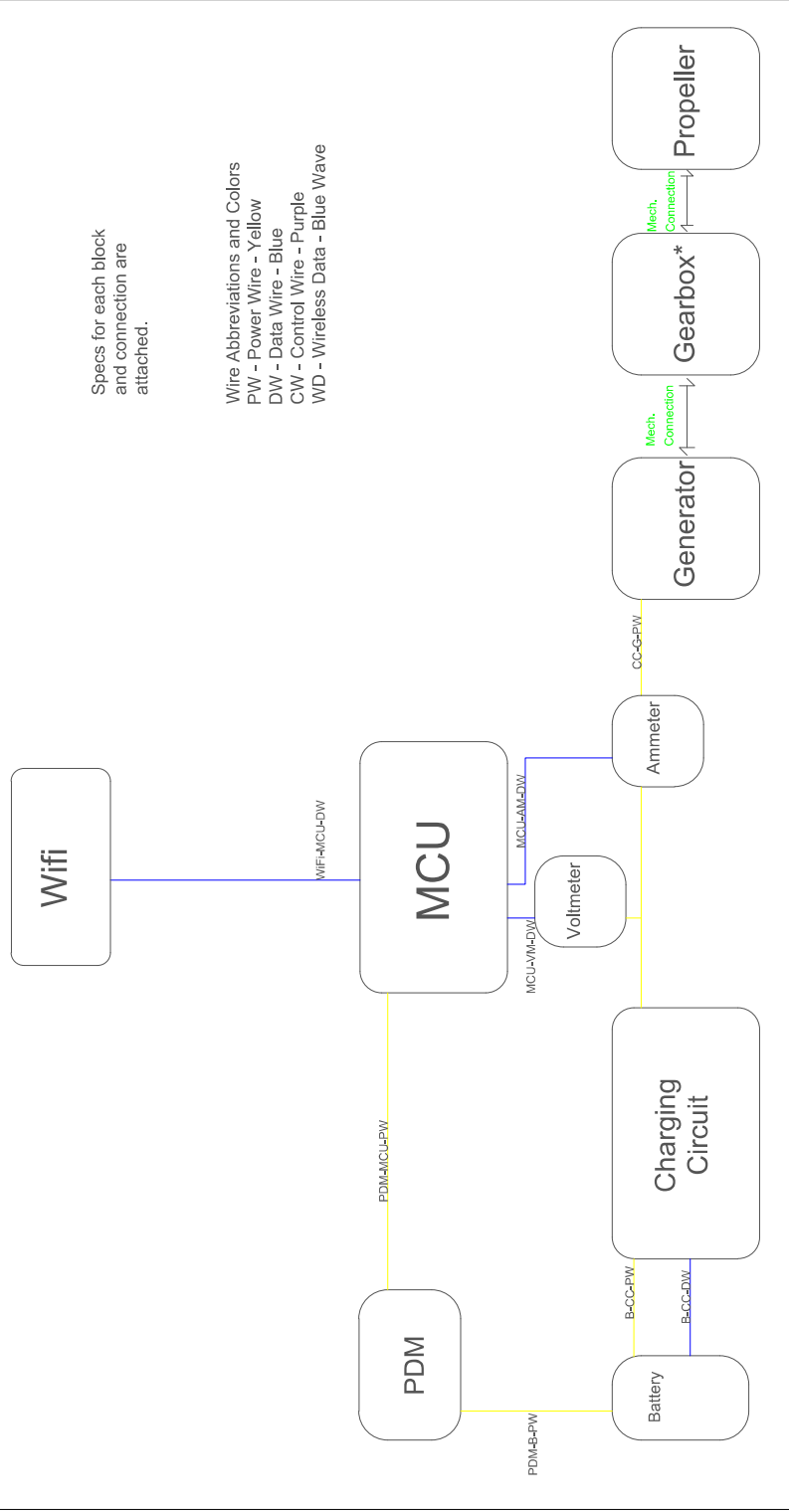

## Appendix C: Production Version Block Diagram Specifications

[This page is intentionally blank the next page starts the Specifications]

# TEST System Block Diagram Specifications

Revision C

# Table of Contents

<b>Table of Contents</b>	<b>1</b>
<b>Preface</b>	<b>3</b>
<b>Underwater Sensing Device</b>	<b>4</b>
Transducer	4
T-SM-DW	4
Sonar Modem	4
SM-PDM-PW	5
SM-MCU-DW	5
PDM	5
PDM-B-PW	5
PDM-MCU-PW	6
MCU	6
MCU-CC-DW	6
MCU-VM-DW	6
MCU-AM-DW	7
Voltmeter	7
Ammeter	7
Battery	7
B-CC-PW	8
B-CC-DW	8
Charging Circuit	8
CC-G-PW	8
Generator	8
Gearbox	9
Propeller	9
<b>Data Relay Buoy</b>	<b>9</b>
DRB-USD-WD	9
DRB-CN-WD	9
MCU	10
MCU-CC-DW	10
MCU-SM-DW	10
MCU-CM-DW	10
Solar Cell	10

SC-CC-PW	11
Charging Circuit	11
CC-B-PW	11
CC-B-CW	11
Battery	11
PDM	12
PDM-MCU-SM-CM-PW	12
Sonar Modem	12
SM-PDM-PW	12
SM-T-DW	13
Transducer	13
Cellular Modem	13
CM-A-DW	13
Antenna	13
<b>Shore Station</b>	<b>13</b>
Cellular Network	14
Database	14
Web Page	14
<b>Appendix 1</b>	<b>15</b>

# Preface

The following is a list of specifications for each block and connection in the the TEST system block diagram revision A. Some specs may have more detail than others at this stage of the designs, more detail will come in following revisions. Some blocks may be later modified or omitted all together.

Note on the formatting of this document. The blocks will be grouped by what device they are located on, as shown on the diagram drawing. Within each device blocks will be listed top-down, left-right, as shown on the drawing. Associated connections will be listed under the leading block in the name of the connection on the drawing. For example connection SM-MCU-DW will be under the Sonar Modem's specs.



# Underwater Sensing Device

- The device will be placed underwater at a depth of 20 - 300 meters
  - Will be placed within 2-5 kilometers of another device
  - Cased together with the transducer and the MCU for its underwater suitability.
- 

## Transducer

- Purchased and packaged with the Sonar Modem
- Omni-directional beam pattern

## T-SM-DW

- Transducer to Sonar Modem Data Wire.
  - Transfers signal generated by the Sonar Modem to the transducer.
  - Comes preinstalled with Transducer, not necessary to design.
  - Should be suitable to underwater environments.
  - Will be in close proximity to modem so length is not a large concern but should be long enough to reach but not so long as to be unmanageable. In the range of 1-3 ft would be ideal if available
- 

## Sonar Modem

- Will spec around the [DSP AquaComm](#)
- Power Supply Voltage: 5 to 12VDC
- Current:
  - 24mA transmitting
  - 2.4mA receiving
  - <150  $\mu$ A standby
- Range: 3km
- Data rate: 100 bits per second
- Included error correction
- Uniquely addressable
- Comes with networking support. See support doc linked in Appendix B.

## SM-PDM-PW

- Sonar Modem to Power Distribution module Power Wire
- Provides power to the Sonar Modem
- Voltage Rating: 5V
- Current Rating: 24mA

## SM-MCU-DW

- Sonar Module to MCU Data Wire
  - Transfers data packets from the MCU to the Sonar Modem to be send to the data relay buoy
  - Will likely use RS-232 digital serial interface
  - RS232 serial communications.
  - 9600 baud (default), 1 start bit, 1 stop bit, no parity
  - 4800, 2400 or 1200 baud programmable
  - Either TTL voltage levels (3.3V) or RS232 voltage levels selectable
  - Simple ASCII command set to configure and command the modem
- 

## PDM

- Power Distribution Module
- Responsible for providing power from the battery to the MCU and Sonar Monitor
- Should include protective circuitry to protect the sensitive electronics in the MCU and Sonar Monitor things like Over/Under Current or Voltage.
- Both devices run on 5V so the PDM will need a boost converter to up the voltage from the battery 3.7V
- Boost converter like [TPS61256](#) (Surface Mount) or
- $V_{in} = 2.3$  to  $5.5$
- $V_{out} = 5V$
- $I_{out} = \sim 1.3$  A
- [LT1302-5](#) (Through Hole)
- $V_{in} = 2$  to  $8$  V
- $V_{out} = 5V$
- $I_{out} = \sim 2A$

## PDM-B-PW

- Power Distribution Module to Battery Power Wire
- Provides power for Power Distribution Module

- Voltage: ~5

## PDM-MCU-PW

- Power Distribution Module to MCU Power Wire
  - Provides appropriate amount of energy to power MCU.
  - Power requirements depend on MCU selected (RS485)
  - Voltage: ~5V
- 

## MCU

- NUC029TAN(<https://www.techdesign.com/market/product/Embedded-Processors-and-Controllers/Microcontrollers-MCU?search=NUC029TAN&is=false&pu=9&p=1> Price:1.08 dollar)
- Arm® Cortex®-M0 micro-controller
- Compatible with either RS232 or RS485
- Voltage rating: 2.4V-5.5V
- Operating frequency: up to 50MHz
- Industrial temperature grade: -40~+105°C
- 2 UART
- 32K data flash
- 4K SRAM
- 4K LDROM
- Supports ISP/ICP/IAP
- Clocks: External 4-24Mhz; Internal 22.1184Mhz
- 10kHz low power oscillator for Watchdog and Wake up in sleep
- Will track the data from the voltage and current sensors on the generator.
- Change notice: In Rev\_A the MCU was going to be responsible for the battery charging. In revision B that has been handed off to the integrated charging circuit. Depending on the charging circuit chosen there may be communication possible between the MCU and charging circuit.

## MCU-CC-DW

- Programs the charging IC.

## MCU-VM-DW

- Transfers voltage information from Voltmeter to MCU

## MCU-AM-DW

- Transfers current information from Voltmeter to MCU
- 

## Voltmeter

- Measures the voltage coming from the generator using ADC onboard MCU.
- This with the ammeter will be how we determine the speed of the water. By knowing the power generated by the generator and the parameters of the propeller we can calculate the speed of the water.

## Ammeter

- Measures the current coming from the generator
  - Measured by shunt resistor and op-amp for amplification.
- 

## Battery

- The battery will need to be able to supply power during slackwater.
- The industry standard for battery technology is Lithium battery and this should follow that standard.
- Should be able to store the total energy produced daily by the generator, based on the calculators from the current revision that is about 3.5 WH. Total energy use by the device is less than 1 W so this extra capacity will let the device stay on if there is an issue with generator. Also by doing this the battery will be kept at a high percentage of charge which is good for the battery chemistry.
- Closest commercially available is 5.5 WH which should not be an issue
- Below is a spec part, actual should be this is similar
- [Polymer Li-Ion Cell: 3.7V 1500mAh \(703562-2C, 5.55Wh, 3A rate\) - UN38.3 Passed -](#)
- Voltage: 3.7 V
- Discharging Current(Max): 3.0A
- Charging Current(Max): 1.5A
- Capacity: 1500 mAh            5.55 WH
- Dimensions: 65mm x 35.5mm x 7.0mm
- Weight: 28 grams

## B-CC-PW

- The charging current of the battery will travel on this connection
- Voltage: 3.4-4V
- Current(Max): 1.2A

## B-CC-DW

- Provide temperature data to the charging IC
- 

## Charging Circuit

- Must allow for generator to spin in both directions, mean voltage on input must be reversible.
- Two stage:
- Stage one is a full bridge rectifier to convert the generator current to DC
- Stage two is an integrated lithium battery charger.
- Suitable ICs will depend on the final Generator choice but some possible choices include:
  - [MAX8900](#)
  - [FAN5400](#)
  - [BC3770](#)
- All have similar specs so sing the MAX8900 as an example
  - Voltage in: 3.4 to 8.7 V
  - Charge Current(Max): 1.2
  - All options are very customizable

## CC-G-PW

- The raw current generated by the generator is send to the charging circuit to charge the battery which powers the device.
- 

## Generator

- Ideally the generator would operate most efficiently at the rotational speed that the propeller spins at under normally usage, so that the gearbox could be omitted.
- Should be a brushed DC motor, if AC then a rectifier would need to be added.

- The power rating should be over the maximum current power expected to protect against the cases of exceptionally high currents.
- 

## Gearbox

- The gearbox will convert the propeller shaft speed to the one required by the generator to operate efficiently.
  - The exact reduction would be based on the generator, propeller, and area of deployment
- 

## Propeller

- The propeller requires special design to be efficient at the low speeds it is meant to be operated in. For an axial rotor type this would require a specific pitch and diameter.
  - The power that can be extracted over a tidal current range from the current for a propeller with a given efficiency and diameter can be calculated using the Matlab program in Appendix 1
- 

## Data Relay Buoy

- This device will relay data from the Underwater Sensing Device using SONAR communication to the shore station using GSM cellular.
- Will be equipped with a solar cell and battery so that it can self-power data transmission.

### DRB-USD-WD

- SONAR communication.\*

### DRB-CN-WD

- Communication to the cellular network, used to upload the data from the devices. The data should be directly uploaded to a database.
-

## MCU

- Primarily responsible for taking in the data from the sonar modem and sending it to the cellular network.
- Must use the cellular modem to establish a TCP connection with the server and check the integrity of the connection.
- Must strip down the incoming transmissions from the USD to the bare data, then put into a format to be entered into a SQL table.
- Will also interface with the charging circuit.
- NUC029TA the same as the underwater sensing device.

## MCU-CC-DW

- Controls the function of the charging circuit.
- Serial Connection

## MCU-SM-DW

- The incoming transmissions from the Underwater Sensing Device received by the sonar modem.

## MCU-CM-DW

- Connects the MCU to the Cellular Modem.
- 

## Solar Cell

- The size of the cell depends on a few factors.
  - One is the device power usage, this will depend on the number of devices in the network, because it has to communicate with all of them.
  - Two the location of the deployment and time of year some locations get more solar energy than others. For design purposes we will use New York City during the summer for our design and then factor in a large safety margin
- Will likely be a 12V panel because they are a popular size for use in charging car batteries
- Can be maximum 18W with the selected charging chip. That should be more than enough capacity based on the preliminary information the cellular modem will use at most 2W
- For the demo version a smaller cell can be used. Like FIT0601-ND
  - $V_{oc} = 7.2V$
  - $I_{sc} = 1.1A$

## SC-CC-PW

- Supplies the current from the solar panel to the battery charging circuit.
  - Voltage: 3.9-14V
  - Current: 100mA to 3.5 A
- 

## Charging Circuit

- It is good practice in design to use the same parts where appropriate however in this case the power generation from a solar panel is going to be much different than the power from the underwater generator and for this reason we find it better to use a different charging IC.
- The [TI bq25898](#) seems better suited to a solar cell application because it allows for a higher input voltage and higher charger current, to be able to take advantage of the solar power while it is available. Also because the cell will not generate at night and possibly for several days during adverse weather the battery will need to be much larger than the underwater device.
- Voltage input: 3.9 -14V
- Charging current (Max): 4A
- I2C controlled
- This should allow us to use a solar panel upto 18 W

## CC-B-PW

- Charging current
- Current (Max): 4A
- Voltage: 3.4-4.5V

## CC-B-CW

- Information about charging like temperature and voltage level.
- 

## Battery

- Will need to be much larger than the underwater device because it will have to last all night with no power generator or even several days of adverse weather.



- Most likely will be based around an 18650 package due to its large capacity and widespread availability.
  - Will have low current draw likely less than 1A
  - Single cell voltage of 3.7V
  - For the demo version the same battery as the Underwater Sensing Device can be used.
- 

## PDM

- Converts battery voltage (3.7) to operating voltage 5V
- Boost converter like [TPS61256](#)
- $V_{in} = 2.3$  to 5.5
- $V_{out} = 5V$
- $I_{out} = \sim 1.3 A$

## PDM-MCU-SM-CM-PW

- Provides power to all modules of the device
- 

## Sonar Modem

- Will use the same manufacturer as the modem of the underwater device, specs copied.
- Will spec around the [DSP AquaComm](#)
- Power Supply Voltage: 5 to 12VDC
- Current:
  - 24mA transmitting
  - 2.4mA receiving
  - $<150 \mu A$  standby
- Range: 3km
- Data rate: 100 bits per second
- Included error correction
- Uniquely addressable
- Comes with networking support. See support doc.

## SM-PDM-PW

- Provides power from the boost converter that brings the 3.7V battery voltage to the required 5V.

## SM-T-DW

- Signal received from transducer is send to the Sonar Modem
- 

## Transducer

- Solid dunking transducer from DSPcomm.
  - Piezoelectric transducer that sends SONAR waves through the water.
- 

## Cellular Modem

- Should have direct data connection. Will require subscription to a network provider.
- Research shows 5 to 12 mile range off shore near populated areas.
- Will likely use the GSM network protocol.
- Will use AT commands to establish a tcp connection to the server and then upload the data in a SQL format
- Adafruit FONA should work well: <https://www.adafruit.com/product/1946>

## CM-A-DW

- Data from the cellular modem is transferred to the antenna to be sent to the internet
- 

## Antenna

- Must be chosen to be compatible with both the modem and network provider.
  - Slim Sticker-type GSM/Cellular Quad-Band Antenna - 3dBi uFL  
<https://www.adafruit.com/product/1991>
- 

## Shore Station

- In this revision the Shore Station is not a physical location, rather a virtual one. The data from the USDs are sent over the cellular data network to database(SQL server). The data on that server can then be accessed by a webpage to display the information, or tailored to the needs of the client

---

## Cellular Network

- Must support “data” access, meaning the network must allow for connection to an IP address.
- Most likely GSM.
- Will connect using AT commands to establish a TCP connection with the server, then SQL commands can be executed on the server to upload the data.

---

## Database

- Must be able to be remotely accessed by both a webpage and the Data relay buoy.
- Will most likely use a SQL server. For testing this server can be run on a remote machine, in production it will be hosting on a dedicated server.
- Will hold a table with the data for each device, and a table that maps the devices to a location.

---

## Web Page

- Will access the SQL database and display the data.
- Should organize the data, most likely by device.
- Ideally it could overlay the points on a map.

# Addendum 1

Matlab code to find the power generated by the prop in a sinusoidal current.

```
t = linspace(0,4*pi,1000);
plot(t, findPower(t))
findP = @findPower;
Energy = integral(findP, 0, 4*pi)

AvgP = Energy* (1/(4*pi-0))

function P = findPower(t)
max_current_speed = 1.5; %Maximum current speed in an area
current_cutoff = 1.25; %Minimum current speed that will generate
power
p = 1000; %Density of water
A = .002; % Sweep Area
%P = .166; %Current Power
n = .25; %Efficiency
current = abs(max_current_speed * sin(t));;

%Cuts of power for currents behold threshold
cutoff_current = zeros(1,length(current));
for i = 1:length(current)

    if current(i) > current_cutoff
        cutoff_current(i) = current(i);
    end
end
%plot(t,cutoff_current)
P = .5 * n * p *A* cutoff_current.^3; %Power calculation

End
```

## Appendix D: Full Page Circuit Schematic

[This page is intentionally blank the next page contains the circuit schematic]

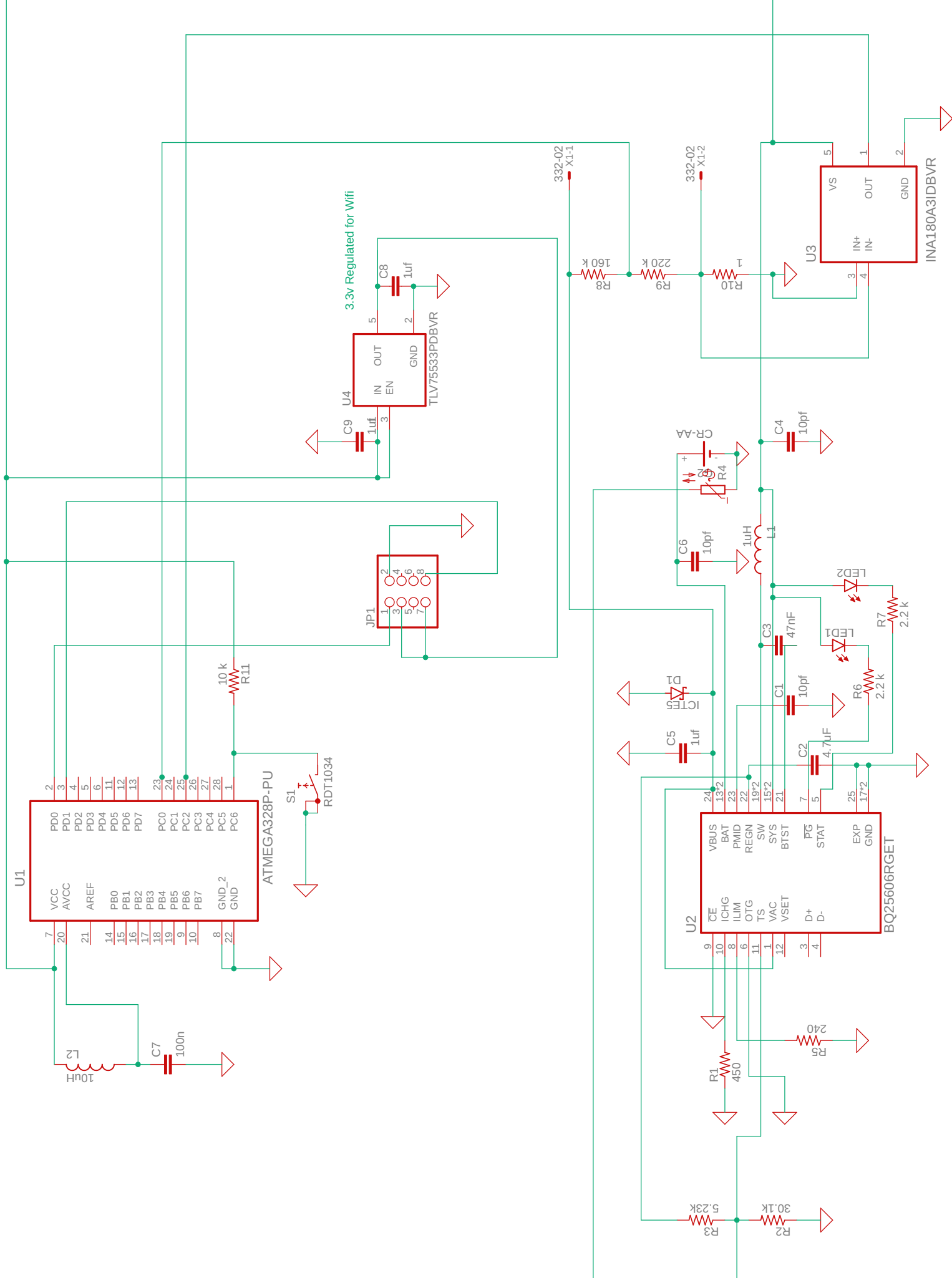

## Appendix E: Microcontroller Measurement Code

```
void loop() {  
  //Serial Monitor for computer at 9600 bytes/sec for testing  
  Serial.begin(9600);  
  
  //Voltage monitor input  
  int voltageValue = analogRead(A0);  
  
  //Amperage input  
  int ampValue = analogRead(A2);  
  
  /*Current Processing.....  
  */  
  //Resistor Values (Placeholder one)  
  float shuntResistor = 1;  
  float amplification = 100;  
  
  //Converts AmpValue from int 0-> 1023 to Float 0.0 -> 5.0  
  //Actual voltage coming from OpAmp  
  float ampValueFloat = ampValue * (5.0/1023.0);  
  
  //Equation to convert Low-Side Current Sense Circuit output to voltage across shunt  
  float shuntVoltage = ampValueFloat / amplification;  
  
  //Convert Voltage to current  $I = V/R$   
  float shuntCurrent = shuntVoltage/shuntResistor;  
  /*Voltage Processing.....  
  */  
  //Resistor Values (Placeholder)
```

```

float voltageDividerR1 = 160;
float voltageDividerR2 = 220;

//Converts voltageValue from int 0->1023 to Float 0.0 -> 5.0
float voltageValueFloat = voltageValue * (5.0/1023.0);

//Equation to convert voltage divider output to the full generator voltage
float generatorVoltage = (voltageValueFloat * (voltageDividerR1 +
voltageDividerR2))/voltageDividerR2;

//Find instantaneous power
float generatedInstantPower = generatorVoltage * shuntCurrent;

//Calculate flow velocity equation determined imperically
float flowVelocity = 0.841 * generatedInstantPower + 0.131;

delay(10000); //Take measurements every 10 seconds
}

```



## Appendix F: PHP Code

This code is used on a XAMPP web server and allows for data to be entered into a MySQL database using HTTP requests. Note this code could not be used in production because it lacks security. Anyone with access to the IP address of the web server has full access to the MySQL database. The SQL requests are allow not protected against SQL-injection attacks, however this code is just meant for testing.

```
<?php
    // Prepare variables for database connection
    $dbuser = "arduino"; // enter database username
    $dbpass = "test"; // enter database password
    $dbhost = "localhost";
    $db = "currents";

    // Connect to database
    $conn = mysqli_connect($dbhost, $dbuser, $dbpass, $db);

    // Check connection
    if (mysqli_connect_errno())
    {
        echo "Failed to connect to MySQL: " . mysqli_connect_error();
    }
    // Prepare the SQL statement
    $sql = "INSERT INTO currents.flowvelocities (Velocity) VALUES
    (".$_GET["value"].")";

    // Execute SQL statement
    mysqli_query($conn,$sql);

?>
```