

Creating A Wireless OBDII Scanner

A Major Qualifying Project Report
Submitted to the Faculty
of the
WORCESTER POLYTECHNIC INSTITUTE
In partial fulfillment of the requirements for the
Degree of Bachelor of Science
in
Electrical and Computer Engineering
by

John Keenan III

This 30th day of April, 2009.

Project Advisor:

Professor Stephen J. Bitar

Abstract

This project consisted of the creation of a wireless On-Board Diagnostics scan tool which implemented communications wirelessly. The main goal of the project was to be able to read codes from a diagnostics port on a vehicle and report the codes wirelessly to a computer receiver. The end result was a wireless communication device which utilized standard RS232 data communication to send and receive codes.

Table of Contents

| | |
|--|----|
| Abstract..... | 1 |
| Table of Figures | 5 |
| Table of Tables | 6 |
| 1 Background..... | 7 |
| 1.1 The Clean Air Act | 7 |
| 1.2 The Air Quality Act..... | 7 |
| 1.3 On-Board Diagnostics | 8 |
| 1.4 Standardization of On-Board Diagnostics..... | 10 |
| 1.5 Introduction of OBD-II | 10 |
| 1.6 Types of OBD-II | 12 |
| 1.6.1 Implementation of OBD-II | 12 |
| 1.6.2 SAE J1850 | 14 |
| 1.6.3 ISO 9141-2..... | 28 |
| 1.6.4 Controller Area Networks..... | 30 |
| 1.6.4.2 Message / Frame Types | 31 |
| 1.6.4.3 Data Transmission Breakdown | 32 |
| ISO 11519, Breband.net, <i>CAN Information</i> | 39 |
| 2 Project Definition..... | 44 |
| 2.1 Understanding Possible Target Markets | 44 |
| 2.1.1 AutoZone | 44 |
| 2.1.2 Emissions Testing Garages | 46 |
| 2.2 Customer Requirements | 47 |
| 2.3 Product Specifications..... | 47 |
| 3 Product Design..... | 48 |
| 3.1 System Flow | 48 |
| 3.1.1 Mobile Wireless Unit..... | 49 |
| 3.1.2 Base Station Unit | 60 |
| 3.2 System Block Diagram..... | 62 |
| 3.3 Hardware Assembly | 63 |
| 3.3.1 Final Hardware Purchase List..... | 63 |
| 4.1.2 Identification of Interfaces | 70 |
| 4 Signal Representations..... | 71 |
| 4.1 OxBB | 71 |
| 4.2 Ox55..... | 72 |
| 5 Communication..... | 74 |
| 6 Recommendations..... | 83 |
| 6.1 Multiple Mobile Wireless Units..... | 83 |
| 6.2 Scan Tool Implementation | 84 |
| 7 Conclusions..... | 84 |

Bibliography 87
Appendixes 879

Table of Figures

| | |
|--|-------------------------------------|
| FIGURE 1 - TERMINAL IDENTIFICATION FOR ON BOARD DIAGNOSTICS PORT | 9 |
| FIGURE 2 – OBD-II FEMALE ADAPTER | 11 |
| FIGURE 3 - LAYER PROTOCOL IN USE FOR THIS SYSTEM | 13 |
| FIGURE 4 - SAE J1850 VPW WAVEFORM | 16 |
| FIGURE 5 - J1850 MESSAGE | 18 |
| FIGURE 6 - J1850 MESSAGE HEADER FRAME | 19 |
| FIGURE 7 - SAE J1850 BIT SYMBOL TIMINGS | 21 |
| FIGURE 8 - PWM WAVEFORM EXAMPLES | 23 |
| FIGURE 9 - BIT DEFINITIONS FOR J1850 (VPW) | 25 |
| FIGURE 10 - J1850 VPW WAVEFORM USING PWM SIGNALS | 27 |
| FIGURE 11 - STANDARD FRAME BREAKDOWN, WIKIPEDIA.COM | ERROR! BOOKMARK NOT DEFINED. |
| FIGURE 12 - EXTENDED FRAME BREAKDOWN, WIKIPEDIA.COM | ERROR! BOOKMARK NOT DEFINED. |
| FIGURE 13 - CAN PROTOCOL, KVASER.COM | ERROR! BOOKMARK NOT DEFINED. |
| FIGURE 14 - CAN BIT TIMING DIAGRAM, ROCKETMAGNET | ERROR! BOOKMARK NOT DEFINED. |
| FIGURE 15 - CAN NETWORK IN PRACTICE | ERROR! BOOKMARK NOT DEFINED. |
| FIGURE 16 - MOBILE WIRELESS UNIT BLOCK DIAGRAM | 49 |
| FIGURE 17 - MOBILE WIRELESS UNIT FINAL BLOCK DIAGRAM | 50 |
| FIGURE 18 - BASE STATION UNIT BLOCK DIAGRAM | 61 |
| FIGURE 19 - SYSTEM BLOCK DIAGRAM | 63 |
| FIGURE 20 - ARDUINO PIN CONFIGURATION | 66 |
| FIGURE 21 - XBEE SHIELD | 70 |

Table of Tables

| | |
|---|----|
| TABLE 1 - J1850 PROTOCOL OPTIONS (VALENTINE, 1998)..... | 15 |
| TABLE 2 - CAN MESSAGE TYPES..... | 32 |
| TABLE 3 - STANDARD FRAME DEFINITIONS..... | 34 |
| TABLE 4 – EXTENDED FRAME DEFINITIONS | 35 |

1 Background

1.1 The Clean Air Act

Over the span of the 20th century, citizens of the United States have witnessed the birth and growth of one of today's largest industries, the automotive industry. By 1960 the number of automobiles on the road rose to over 74 million and would continue to rise throughout the decade. Originally identified by Congress's Air Pollution Act of 1955, Congress acknowledged that air pollution may result in major harm to the public welfare from personal health to national health of the country and with a 25 million dollar grant "An Act to provide research and technical assistance relating to air pollution control" was executed.

After eight years The Public Health Service's research concluded the necessity for a standardized form of regulation by local and state governments in order to protect the well being of the public. In 1963, Congress passed The Clean Air Act, "An Act to improve, strengthen, and accelerate programs for the prevention and abatement of air pollution." Exhaust from these vehicles was the largest factor in their pollution and would soon result in national emission standards. Another major influence to the amount of pollution was the oil being used which of contained high levels of sulfur, the Clean Air Act mandated that research and development would remove the sulfur from the fuels being used.

1.2 The Air Quality Act

A major stepping stone came in 1967 with the Air Quality Act. This Act divided the United States into Air Quality Control Regions in an effort to monitor ambient air. With continued

research, the 1970 Clean Air Act, "An Act to amend the Clean Air Act to provide for a more effective program to improve the quality of the Nation's air," was put into effect.

President Richard Nixon formed the Environmental Protection Agency (EPA) in the interest to protect human health and the United States' air, water, and land. Under the 1970 Clean Air Act, the EPA received thirty million dollars to develop and enforce emission standards and regulations to minimize airborne contaminants such as those made by engine combustion; Sulfur Oxides, Carbon Dioxides, Hydrocarbons, and Nitrogen Oxides. The EPA developed minimal regulations of all 1975 models to emit 90% less Hydrocarbons and Carbon Monoxide in comparison to those of 1970 models. Nitrogen Oxides would be given until 1976 models to be reduced by 90%. To make sure the Automotive Industry was adhering to the newly formed emission regulations the EPA enforced an enormous ten thousand dollar fine for every vehicle built that did not meet specifications. From 1975 through 1980 the EPA worked hand in hand with the Automotive Industry and continuously granted extensions in an effort to lower Hydrocarbons and Carbon Monoxide.

1.3 On-Board Diagnostics

A milestone for automotive efficiency arrived in the forms of On-board computers On-Board Diagnostics, OBD, beginning in 1980. These computers would monitor the fuel injection systems and would have simple capabilities and adjustments, in return, were the start of something great to come. The General Motors Company became the first to build an interface in their vehicle in 1982, the Assembly Line Communications Link. By 1986, the ALCL, known as the ALDL, Assembly Line Diagnostic Link, seen below in Figure 1 - Terminal Identification for

On Board Diagnostics Port, had developed into a much better system where the problem with inconsistency in communication links had been resolved with the implementation of The Universal Asynchronous Receiver/Transmitter.

The original On Board Diagnostic interface included twelve input bays, nine of which were connected to a line of some sort. Each line had a specific function and communicated utilizing a non standard protocol. A drawing representation of the original on board diagnostics port can be found in Figure 1.

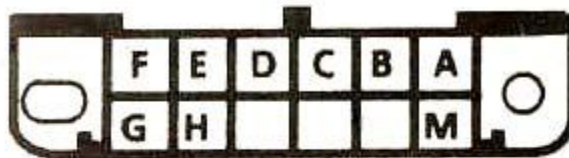

13.16 The assembly line communications link (ALCL) terminal identification (Sec 4)

- | | |
|---|-----------------------------------|
| <i>A Ground</i> | <i>F TCC (if used)</i> |
| <i>B Diagnostic terminal</i> | <i>G Fuel pump (if used)</i> |
| <i>C AIR (if used)</i> | <i>H Brake sensor speed input</i> |
| <i>D Check engine light (if used)</i> | <i>M Not used on V6 or V8</i> |
| <i>E Serial data (special tool required — do not use)</i> | |

Figure 1 - Terminal Identification for On Board Diagnostics Port¹

¹ Robert Powers Motorsports - http://robertpowersmotorsports.freesevers.com/images/ALDL_plug.jpg

1.4 Standardization of On-Board Diagnostics

Throughout the growth of emission standards and regulations, the state of California was the backbone for many of the changes that took place. The California Air Resource Board (CARB) enforced that all new vehicles that would be sold in California in 1988 would have an On-Board Diagnostic system incorporated. This became known as OBD-I. In an effort to clean the air, the CARB anticipated that by monitoring the vehicles overall efficiency by enforcing yearly emissions testing, the public would desire vehicles that would more reliably pass inspection. Unfortunately, due to the lack of standardization of the emissions tests and the variety of OBD-I systems from different manufactures, the annual emissions testing was a long way from where it needed to be to enforce the public's vehicles to meet any regulations. In collaboration with the EPA, CARB conducted an OBD-I case study.

1.5 Introduction of OBD-II

California again led the emissions standards into the next era after six years of on board diagnostics research. The next generation diagnostics interface was called OBD-II. All new vehicles sold in California after 1996 are required to meet OBD-II specifications and standards.

OBD-II is a result of the years of research and development by the Society of Automotive Engineers (SAE), the CARB and the EPA. Incorporating OBDIs positive aspects, these engineers developed a system that would be standardized throughout the country in an effort to successfully enforce emissions standards.

OBD-II standards required a standardized diagnostic connector and location, consistent signaling transfer of information, as well as the format of information transferred. The Data Link Connector, DLC seen below in Figure 2, is the standard “pin-out” connector for OBD-II. The standard also mandated what aspects of the vehicles would be monitored and of what caliber. In the event that a vehicles system was not operating according to emissions standards, the Diagnostic Trouble Code would appear in the dashboard of the vehicle, often in the generic form of a "check engine light." Due to this easy identification of common trouble codes, annual emissions testing became possible, the nation followed suit and mandated that all new vehicles sold in the country must meet OBD-II standards.



Figure 2 – OBD-II Female Adapter²

² Speed Scene Wiring – <http://www.speedscenewiring.com>

1.6 Types of OBD-II

There are three types of OBD-II. The first, and oldest standard, is ISO 9141-2. This standard was defined by the International Organization for Standardization in 1989 in response to the California Air Resources Board's call for cleaner emissions.

The second standard was standardized by the Society of Automotive Engineers. The standardization defined is the SAE J1850 Communications Standard. This standard can be implemented in one of two ways. The implementation occurs through Variable Pulse Width (VPW), or Pulse-Width Modulation (PWM).

1.6.1 Implementation of OBD-II

One needs to create a new architecture to accomplish the feat of translation. The Mobile Wireless Unit will be responsible for reading any and all messages from the vehicle's OBD-II port and translating these messages to RS232 signals, thus eliminating the ambiguity of understanding which protocol is being used on the Vehicle. This would ensure that any communication on the RS232 line will never be protocol specific, and will always be in the context of speaking to the ELM chip on the Mobile Wireless Unit. This is an important concept for the rest of the project. It is important that only significant information be transmitted to the RS232. This information cannot be tied to a particular protocol, and should ignore any idiosyncrasies among the different protocols.

This means of transporting information is very similar to the problems network engineers first faced when creating the internet. It was decided very early that there would be particular

“layers” to a network, and that each layer would have particular functions that no other layer would ever worry about understanding. This separates the abilities of the layers, and thus allows each layer to be very specialized in its nature.

The proposed architecture for this project is similar to a network layer structure as it has two layers, a physical layer and a application layer. The physical layer would handle all direct communications with the outside interfaces. This includes the OBD-II port on the vehicle, and a possible scan tool made for interfacing with the vehicles OBD-II port. Once any communication came from outside communications, its signal would then be translated into bits, and handed off to the next layer, the transport layer. The transport layer would send the message’s bits through a communications means which would allow another point to translate those bits into a signal that could be read by an outside interface. A picture representation can be seen below in Figure 3.

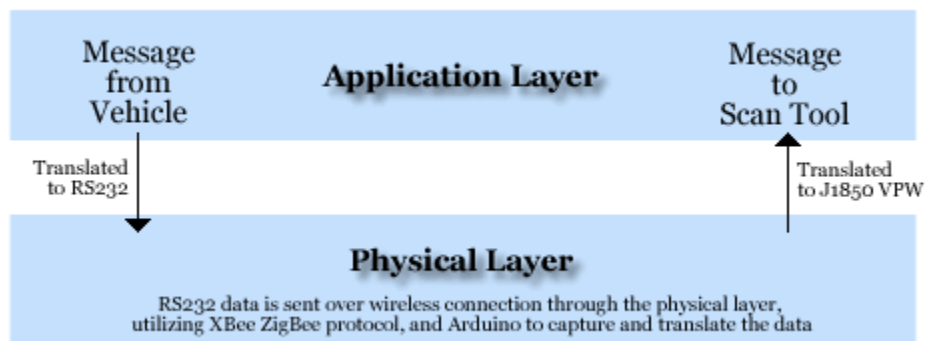

Figure 3 - Layer Protocol in use for this system

As one can see, the separation of functions in this respect helps isolate steps needed in order to interface with different communications means. Particularly when dealing with four different protocols, it can be easy to become overwhelmed with the amount of data being sent. Separating functions into clear layers has allowed us to methodically step through the transmission of this data.

Data coming from the vehicle is translated into RS232 codes using a circuit defined by the Mobile Wireless Unit's project specification. This RS232 signal is then transmitted wirelessly through the XBee ZigBee protocol, to be captured by the Arduino programming environment.

The Arduino then reads the bits, understands what they mean, and translates these bit sets in a way described below to be sent using the VPW protocol. Doing these small steps sequentially allows the transmission of data to be methodical and very precise on the bit level.

1.6.2 SAE J1850

The SAE J1850 standard was a recommended standard for seven years before being officially adopted by the Society of Automotive Engineers in February, 1994.³ The standard which has come to be known as SAE J1850 is a Class B classification. There are two types of pulse modulation. Frequency Division Multiplexing, which transmits two or more messages simultaneously on a single channel, and Time division multiplexing, which interleaves two or more signals on the same channel for either a fixed or a variable length of time.

³ Oliver, D. John: Implementing the J1850 Protocol – Intel Corporation

1.6.2.1 J1850 Implementation Types

There are two implementations of the J1850 standard. The first is Variable-Pulse Width (VPW) modulation. VPW occurs at 10.4Kbps, and uses a variable time length and division multiplexing approach to transmit signals.

The second implementation of J1850 involves Pulse-Width Modulation, or PWM. Pulse-Width Modulation is a method of communication that involves a fixed width pulse. There is a fixed period square wave form which has a duty cycle. PWM is commonly used in drills to change drill bit speed, and light dimmers, which give a linear brightness scale to a light source, allowing the light to have a 0% duty cycle (absolutely dark), or a 100% duty cycle (bright as designed).

| Feature | 1 & 3 Byte Headers | 1 & 3 Byte Headers | 1 Byte Header |
|----------------|-------------------------------|-------------------------------|----------------------|
| Bit Encoding | PWM | VPW | VPW |
| Bus Medium | Dual Wire | Single Wire | Single Wire |
| Data Rate | 41.7 kbps | 10.4 kbps | 10.4 kbps |
| Data Integrity | CRC | CRC | Checksum |

Table 1 - J1850 Protocol Options (Valentine, 1998)

As seen in Table 1, PWM can only communicate over a Dual Wire differential bus, operating at 41.7 kbps. If data is to be checked, the only method for which the data can be verified is through the use of a Cyclical Redundancy Check, or CRC.

1.6.1.3 PWM Explained

PWM is the encoding scheme of choice for all 41.7 kbps J1850 implementations. This standard uses one line of communication

1.6.2.2 VPW Explained

VPW is the encoding scheme of choice for all 10.4Kbaud J1850 implementations. The standard uses two lines for communication, one communication line and one ground reference line. The communication line is defined to be Pin 2 on the OBD-II connector, and the ground reference line is one of the two ground types, Chassis Ground on Pin 4, or Signal Ground on Pin 5. Signal high, known as an Active bit, or logic 1, is represented by +7 volts. Under +3.5 v is defined as a Passive Bit, signal low, or logic 0.

VPW communicates on the data bus via time dependent symbols. More specifically, a “high” bit is not necessarily a high potential on the bus. Through VPW communications, a “one” or “high” bit is a symbol denoted by a transition on the bus that lasts for some fixed amount of time. The amount of time that the bus stays at a particular potential is the determination of which “bit” is being transferred.



Figure 4 - SAE J1850 VPW Waveform⁴

⁴ Oliver, D. John – Implementing the J1850 Protocol

Figure 4 shows a typical VPW Waveform, from low to high. $V_{oh, min}$ is defined to be the minimum output high voltage. This is the highest trip point with the J1850 2v receiver noise taken into consideration. $V_{in, min}$ is the minimum input high voltage. This is the highest value that the active signal will have without noise. V_t is the ideal receiver trip point, where the receiver understands that the signal being given on the bus is active. $V_{il, max}$ is the maximum input high voltage. This is the lowest trip point with no offset noise. $V_{ol, max}$ is defined to be the maximum output low voltage. This is the highest trip point with 2v source noise. Finally, $T_{t, max}$ is the maximum signal transition time, or a maximum of 18.0 μ s.⁵

The VPW J1850 standard defines a high potential bus driven for 64 μ s as a “dominate one” bit.⁶ The VPW J1850 bus is pulled low “weakly,” and driven high by a strong pull-up transistor at each node. A node communicates on the bus by waiting for the bus to be weakly drawn to its low potential at ground, or it can drive the bus to a high potential of approximately 7.5v with the node’s pull-up transistor.

The SAE J1850 standard defines a “high” potential to be anything between 4.25v to 20v. A low potential is anything below 3.5v and above 0v. This inherently allows any node driving the bus to a high potential to overdrive any other node waiting for a low potential before it transmits. The node driving the bus to a high potential will then become the dominate symbols.

⁵ Oliver, D. John – Implementing the J1850 Protocol

⁶ Oliver, D. John – Implementing the J1850 Protocol

Network allocation occurs through the concept of arbitration. Arbitration is a process of determining which of two or more nodes can continue to transmit when both or all network nodes begin transmission simultaneously.⁷ The J1850 bus is an asynchronous bus, which creates a master-less, peer-to-peer network allowing equal access to every node. A transmitting node broadcasts its message to all nodes, including back on its own receive buffer. The node will read its own message through an echo.

1.6.2.3 J1850 Messages

1.6.2.3.1 Message Frames and Format

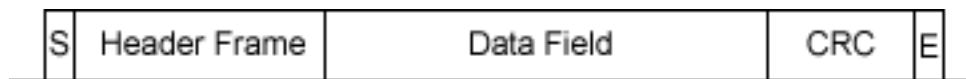

Figure 5 - J1850 Message

Messages are limited to a 12-byte frame (PWM) or a 101-bit frame (VPW), which includes a Cyclical Redundancy Check Byte (CRC) and an In-Frame Response (IFR) byte. This frame is comprised of an Active Start-of-Frame symbol, followed by a series of 8-bit messages, and closed by a Passive End-of-Frame symbol. In the 12-byte frame, data is transferred sending the Most Significant Byte (MSB) first.

The message starts with a Start of Frame (SOF), denoted by the ‘S’ in Figure 5, symbol. This SOF is crucial for carrier sense and arbitration purposes. The SOF is defined as being a high potential on the J1850 bus for a period of 200µs. Once the SOF symbol is transmitted on the

⁷ Oliver, D. John – Implementing the J1850 Protocol

data bus, bit symbols are transferred. Any number of bytes between one and eleven can be transferred.

Message Header Byte-Frame

The header byte contains information about what a receiving node should expect in the proceeding message frame. Once the SOF symbol is sent on the J1850 bus, the header frame is the next set of 8-bits transferred. The Header Frame is pictured in Figure 6.

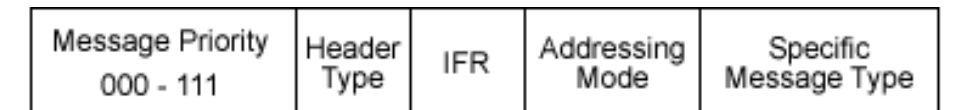

Figure 6 - J1850 Message Header Frame

The first three bits are considered to be the Message Priority value. The priority value ranges from 000 (highest priority) to 111 (lowest priority). This gives 8 values for the priority of a particular message.

The next bit to get transferred is called the “Header Type.” This bit defines the message coming as either being a three-byte message or a one-byte message. A value of “0” in this Header Type value forecasts a three-byte header, while a value of “1” forecasts a one-byte header.

Following the Header Type bit is the In-Frame-Response (IFR) requirement flag. This bit defines whether an In-Frame Response is requested or not. This bit is also called the K-bit. If this bit is set to “zero,” then an IFR is requested. With a “one” bit flagged, no IFR is requested.

Next, the source sends to the bus an Addressing Mode bit, also called the “Y” bit. The Y bit conveys to the receiver that the message is using one of two types of addressing associated with the J1850 protocol. One is a functional type of addressing, and the other is called physical type. If this “Y” bit is set to zero, then functional addressing is used. Conversely, if the Y-bit is set to “one,” then physical addressing is used. Functional addressing has a higher priority than the physical addressing has, providing that all preceding bits are the exact same.

1.6.2.3.2 Functional Addressing

Functional Addressing is a scheme that labels messages based on their operation code or the message’s content. This type of messaging is important for networks where a target receiver node does not have a publically known physical address, but its function to the entire network is known. (Powers, 1992) This and other nodes can be addressed by utilizing a function code, to which the node that has the specific function will answer.

1.6.2.3.3 Physical Addressing

Physical Addressing is an addressing scheme that labels messages based upon the physical address location of their source and / or their destination. While physical addressing is independent of the geographic location, connector pins, and / or wire identification assignments of the node, the addressing occurs for nodes which have a specific hardware identifier. The node with the specific physical address will answer the request (Valentine, 1998).

1.6.2.4 J1850 Bit Definitions

Since all communication which happens on the J1850 Bus is through binary bits, and the active and passive voltage levels have little to do with the bits' value, the time division multiplier must be defined such that the message can be deciphered. There are four types of bits which can be sent on the data bus. The four types are Active 1, Active 0, Passive 1, and Passive 0. These bits are depicted further in a non-scale Figure 7.

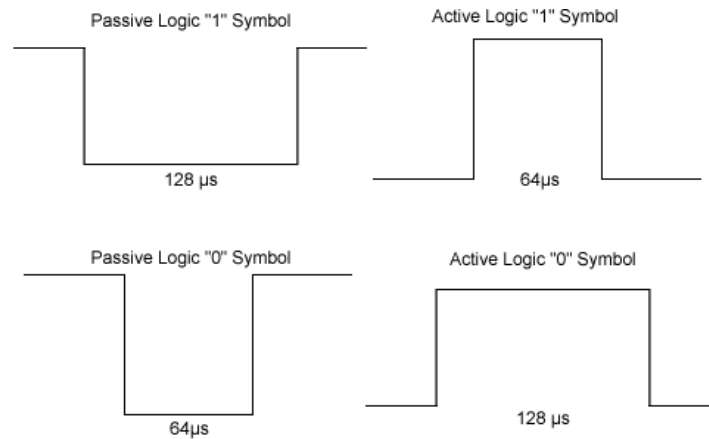

Figure 7 - SAE J1850 Bit Symbol Timings

1.6.2.5 Emulating J1850 VPW Bits

1.6.2.5.1 Bit Emulation Using Software

Sending and receiving data bits using the J1850 VPW protocol involves setting a signal line to high and low for variable amounts of time. This proves to be difficult in that we need an exact time value at every edge on the signal, since the amount of time that the line stays at a particular state is what denotes the value of the bit.

Further, if software is used to generate the waveform, the processes needed to run the other code of the system will be tied up, and the system will only be able to perform one function at a time.

This would cause problems with timing, as well as halt other operations needed to translate, transmit, and receive data. It is for these reasons that software cannot be trusted to perform the exact calculations of each rising and falling edge. With this requirement in mind, it is still helpful to implement a software waveform generation so that the concept can be proven and a waveform resembling the VPW protocol can be created.

Doing so was not difficult. We know the speed of the processor, and how many clock ticks happen with each instruction. We were able to implement a signal that generated 0xAA (0b01010101) on the line at all times. The waveform was a bit off, but this is to be expected with the weight associated with the instructions being used to change the line's state.

1.6.2.5.2 Bit Emulation using Hardware

One of the most important features of the ATmega168 is its timers' ability to enter WGM, or Wave Generation Mode. With WGM, we were able to implement a Pulse-Width-Modulation (PWM) waveform that had a constant period. Having a hardware-implemented timer gives the engineer freedoms that software does not. Most importantly, the engineer is not tied to any other processes when dealing with a hardware timer. No matter what the microcontroller is doing, when a hardware interrupt occurs, the process stops, and a hardware interrupt routine is performed.

PWM by definition has a constant period, with a variable amount of its period that stays at either a high or a low state. Although the period is constant, this variable high or low time, or 'the duty

cycle,' could be changed by setting a particular variable counter that was constantly compared to the counter's value through hardware means. This particular variable ranges from 0 to 256. If one wants a 0% duty cycle, he or she would set this counter to 0. If one wanted a 75% duty cycle, this value would be set to 191. Figure 8 shows two PWM waveforms, one with 90% duty cycle, and one with 50% duty cycle.

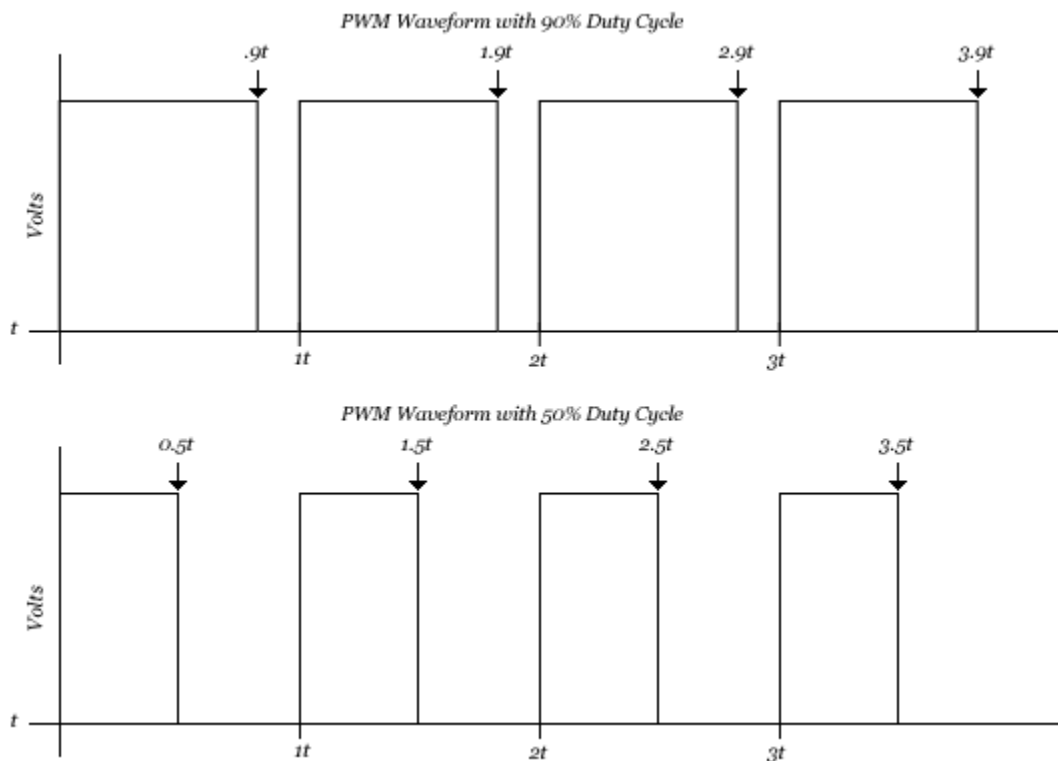

Figure 8 - PWM Waveform Examples

The amount of time that the signal stays at high or low is controllable by a variable, thus allowing an engineer the ability to have 100% duty cycles and 0% duty cycles together in sequences. Understanding this basic concept was instrumental in setting up the VPW signal using a PWM signal.

More specifically, one could set up a timer that interrupts every 16 microseconds. This timer would generate a signal with 100% duty cycle for 4 interrupts, allowing us to generate a “high” signal for 64 microseconds, then switch to a 0% duty cycle thereafter, defined by the J1850 VPW protocol as an “Active 0” signal! So, by allowing a PWM to run for a particular amount of time with a particular duty cycle, we have generated a waveform that conforms to an external communications protocol.

1.6.2.5.3 Generating the Waveform

Now that the generation of particular square waveforms utilizing a variable duty cycle PWM wave is defined, the structure of each bit must be defined utilizing the J1850 spec from the Society of Automotive Engineers. The document clearly explains the data being transferred, but a simpler pictorial is shown below to help explain what each bit looks like. Figure 9 gives another representation of VPW bit formats.

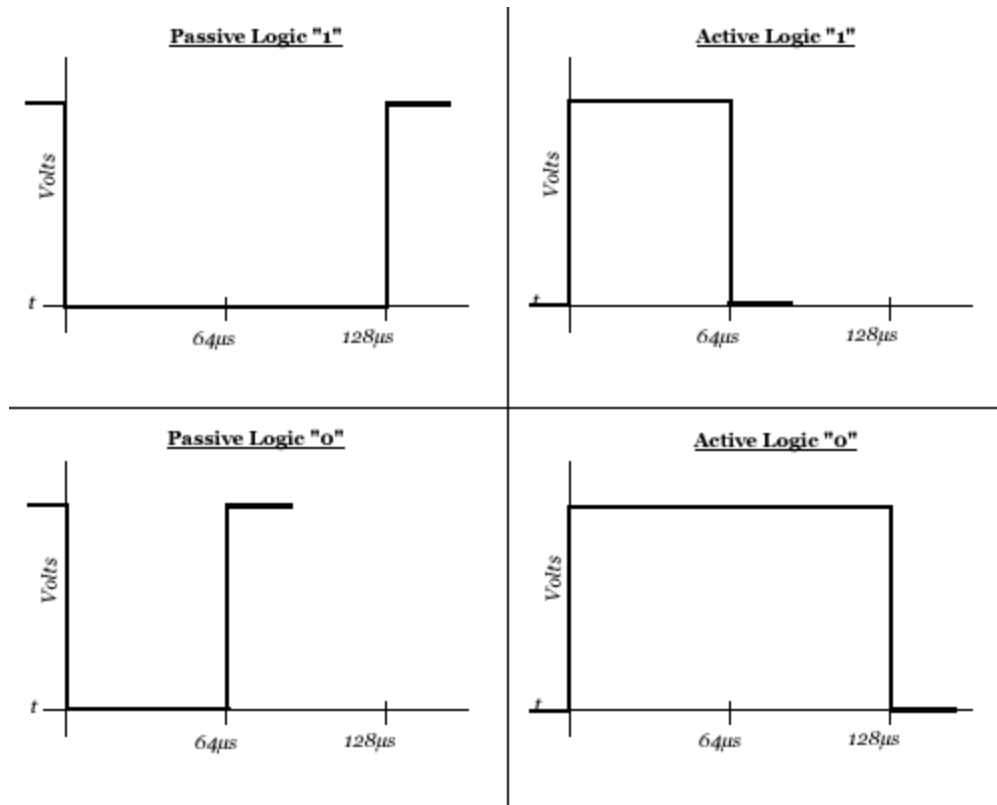

Figure 9 - Bit Definitions for J1850 (VPW)

There are four types of bits, 0 and 1, each having an Active and a Passive state. These states can further be explained as a prioritization scheme. Since SAE J1850 calls for a single-line bus, one can see that many different apparatuses may be trying to communicate at the same time. Not only are these apparatuses trying to communicate at the same time, but their bit streams may be the same for some immeasurable amount of time. It is for this reason that the prioritization scheme was defined, and it was done through the use of time splicing data.

The prioritization scheme utilized by J1850 VPW calls for a pulse of either high or low (which will always alternate, one will never have two high pulses in sequence), for a period of 64 microseconds or 128 microseconds. The network's bus is a "Wired-OR" bus, which means that

if any apparatus is trying to bring the line high, the line will go high. Any apparatus, which sees that it is trying to send a low signal, while the line stays high, will cancel its transmission because J1850 defines this as being a lower priority signal. It is for this reason that the highest prioritized messages will try to keep its signal “high” as much as possible.

It is important to note that a message’s bits will alternate between active and passive, and will never have two active bits in sequence, and additionally will never have two passive bits in sequence. The highest prioritized messages will have most of its bit stream at logic high.

Below is a picture representation of a VPW waveform using a PWM generator. At each falling or rising edge on the waveform, the PWM’s duty cycle is changed from 100% to 0%, or 0% to 100%, respectively. The waveform below in Figure 10 has the bit set 0-1-0-0-1-1.

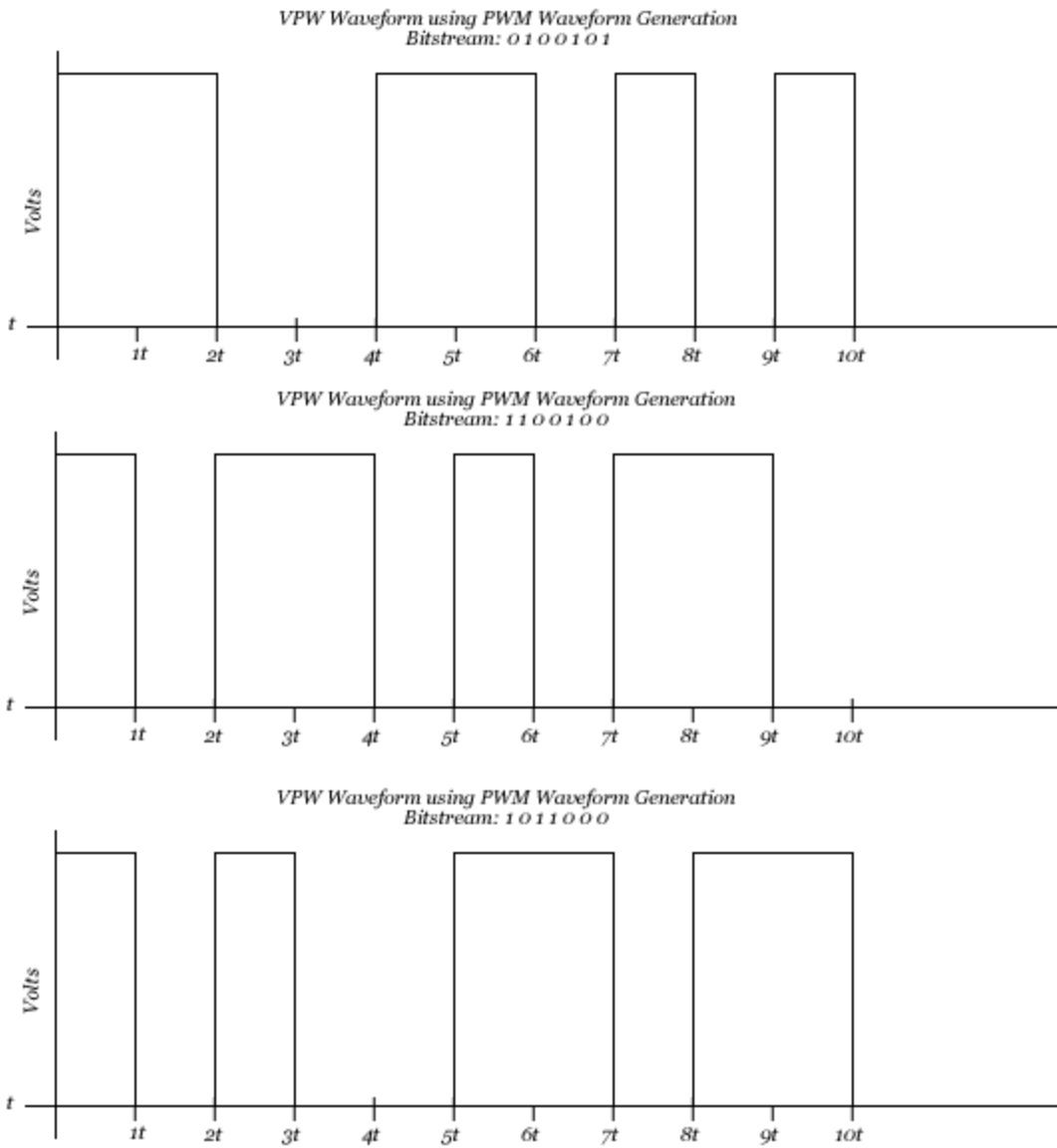

Figure 10 - J1850 VPW Waveform using PWM Signals

The above waveforms in Figure 10 depict true bit transfers of J1850 VPW. Square waves of period of either 64 microseconds or 128 microseconds translate into active and passive bits as defined in Figure 9. With these tools of generating a VPW waveform, one can now begin to

structure bit streams that resemble OBD-II messages, which can be given to scan tools, vehicle OBD-II ports, or alternatively any other communications method utilizing a variable pulse width.

1.6.2.6 J1850 Bus Error Checking

This is a section about J1850 error checking.

1.6.3 ISO 9141-2

1.6.3.1 Speed and Voltages

The ISO 9141-2 protocol is based on serial communication using one of two lines. Pin 7 and Pin 15 are the two lines of communication, and are labeled K line and L line, respectively. Serial communication transfers bits using high and low voltages to represent bits, 0, or low, is represented by a zero volt message, 1, or high, is represented by 12 volts.

Communication through ISO 9141-2 is asynchronous and has a data transfer speed of 10.4 kBaud. Data bits have a maximum high to low propagation delay of 2 microseconds. Similarly, the maximum low to high propagation delay is also 2 microseconds.

This protocol is framed with a certain set of data which includes a header byte, a set of data bytes, and a checksum byte. The frame is the same as the J1850 messages, and follows the same message format. The difference lies in the physical architecture.

ISO 9141-2 has a similar protocol to RS-232. The K line is the communication wire, and the L line is used solely for “waking up” the unit, and is optional and useless other than for this

particular function. The unit can, in fact, be woken up utilizing the K line, which makes the L line somewhat obsolete.

1.6.3.2 Initiation Protocol

Connecting to an ISO 9141 capable OBD-II port requires a sequence of handshaking steps in order to communicate. The process⁸ is as follows:

1. Select the K line from the OBD-II wiring harness to use as Serial Communications
2. Set outgoing communication to 5 baud
3. Transmit a hex value of 0x33h to the OBD-II Port
4. Immediately set incoming/outgoing communications to 10400 baud
5. The line is now half duplex and the OBD-II Port should echo 0x33h
6. A response from the OBD-II will read 0x55h

Since this was the first standard put into place for OBD-II communication, it is somewhat limited in its functionality. There is no error checking available to programmers and it is the slowest type of communication. The communication between the OBD-II scan tool and the OBD-II port is very structured and cannot be interrupted. Once a command is sent, the sender must wait for a response from the receiver.

1.6.3.3 ISO 9141-2 Signaling

The K line of the ISO 9141-2 bus idles high, and is drawn down with messaging. A specific UART is used in the communication, although not at RS-232 voltage levels. High voltage is set at the voltage of the battery.

⁸ Software Development - <http://www.obd.dk/sw.htm>

The message frames are signaled to look the exact same as the J1850 protocol, but is restricted to 12 bytes.

1.6.4 Controller Area Networks

1.6.4.1 CAN Background⁸

Robert Bosch GmbH, the world's largest automotive components supplier, pursued a method to better communication within a vehicle's electrical and mechanical system. Bosch chose the Intel Corporation, the world's largest semiconductor company, to join on this venture. The objective for the electrical and mechanical system project was to make automobiles more efficient in respect to fuel consumption, emissions, weight, and reliability. Together in 1983, these companies delivered the Controller Area Network, CAN.

Controller Area Networks is a protocol that uses content addressed messaging in a broadcast manor. Every node on the network receives every message transmitted. Acknowledgement is immediately sent and the message is then discarded or kept to be processed by each node. By using CSMA/CD (Carrier Sense Multiple Access/Collision Detection) each node can gain access to the bus equally, and by using dominant and recessive identification, the process runs smoothly with the appropriate information arriving first. Fault Confinement is used by CAN to address faulty nodes and if need be, automatically turning them off to guarantee the network's availability.

CAN Protocol patents are owned by Robert Bosch GmbH, and a CAN Protocol License is required as described below in the information from Bosch.com:

“Additionally to the CAN IP modules offered by Bosch, a CAN Protocol License is required. The CAN Protocol License is also required for self-developed CAN modules, or for CAN modules purchased from another vendor. Bosch is licensing the CAN protocol as follows:

1. CAN Protocol License for ASIC-manufacturers and FPGA mass programming

Performance of Bosch:

- Delivery of the CAN Protocol Specification together with comprehensive explanations*
- Delivery of a functional C Reference CAN Model*
- Granting the right to use the CAN know-how and the CAN patents for the manufacture of ASICs or the programming of FPGAs with CAN and their worldwide sale*

2. CAN Protocol License for FPGA Programming

Performance of Bosch:

- Granting the right to use the CAN patents for the programming of FPGAs with CAN and their worldwide sale”*

1.6.4.2 Message / Frame Types

CAN uses a message based protocol often referred to as ‘content-addressed.’ Content-addressed implies that each message has the destination within. A priority and the data to be transferred is embedded into the message and broadcasted to every node on the network. It is up to the nodes to acknowledge that the message was received properly and to discard or process the message. Messages can be sent to an abundance of nodes and processed or processed by a single node according to who is destined to receive it. Messages are referred to as ‘Frames’ and there are four types of frames in the CAN protocol. The frame types are defined as the Data Frame, Remote Frame, Error Frame, and Overload Frame. Each type is explained below in Table 2.

| CAN Message/Frame Types | |
|-------------------------|---|
| Data Frame | Always used when information transmits. |
| Remote Frame | Same properties as a Data Frame with an additional bit to signify it is a Remote Transmit Request (RTR bit) |
| Error Frame | Generated by any node that detects an error. Errors can be of the five error conditions defined by CAN. |
| Overload Frame | Generated to give the nodes processing the message they already received more time. |

Table 2 - CAN Message Types

1.6.4.3 Data Transmission Breakdown

There are two different types of Frame formats. CAN 2.0a (identical to 1.0x) and CAN 2.0b. 2.0a is referred to as ‘standard frame format’ and 2.0b is referred to as ‘extended frame format.’ The arbitration fields consist of either 12 bits or 32 bits. The difference is that Standard frames are composed of 11 bits for the identifier while the extended frame has 29 bits for the identifier. To determine if the format is standard or extended, extended frame format has an additional IDE bit. Frames begin with a SOF, Start of Frame, and bit to denote the start of the transmission. The IDE bit is sent in the form a recessive bit for an extended frame and a dominant bit for standard

frame. The CAN standard requires “the implementation *must* accept the base frame format and *may* accept the extended frame format, but *must* tolerate the extended frame format.”⁸

1.6.4.4 Frame Bit Breakdown^{7,8}

Data Frame:

RTR = 0; The dominant association identifies as a data frame.

Standard Frame: 11 Identifier Bits

Extended Frame: 29 Identifier Bits

Remote Frame:

There is an RTR, remote transmit request, bit identified as 1, a recessive identification. There is also no data field.

Inter-frame Spacing:

Both data frames and remote frames use a bit field to separate themselves from the previous frame. These are called Inter-frames and most often consist of 96 bits. The space is allotted to provide intermission between frames for other transmissions to commence as well as the opportunity to suspend transmission.

Transmission Priority:

Dominant bits are designated with logical 0 and recessive bits a logical 1. Messages include dominant and or recessive bits to identify the importance and resulting in a priority based transmission method. The method is known as automatic arbitration free transmission. The message with the highest priority will be processed while all other messages wait to be resent and processed.

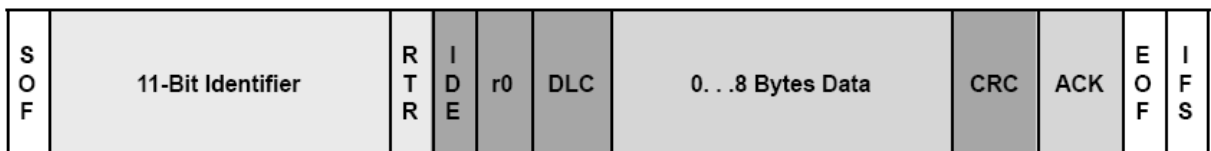

Figure 11 - Standard Frame Breakdown, Texas Instruments, *Introduction to CAN*

| Name | Bits | Definition |
|-------------------|------|---|
| SOF | 1 | Start of Frame bit notates the start of a message. It is also used to synchronize the nodes on a bus when they have been idle. |
| 11 Bit Identifier | 11 | 11 bit identifier includes the priority of the message. A higher priority message, as previously stated, has a lower binary value. |
| RTR | 1 | The remote transmission request bit is dominant in the event that the information is required from another node. |
| IDE | 1 | Identifier Extension bit is a dominant bit that will identify the information to be of standard frame. |
| R0 | 1 | Reserved bit currently not used |
| DLC | | is the Data length code containing the number of bytes of data being transmitted |
| Data | <64 | the data field |
| CRC | 16 | the cyclic redundancy check, 15 bits and a delimiter. The CRC contains the number of bits being transmitted of the preceding application data for error detection |
| ACK | 2 | the acknowledgement bit, plus a delimiter, that every node overwrites after successfully receiving an accurate message. The recessive bit is overwritten with a dominant bit if an error free message has been sent. In the event that a node detects an error, the bit is left as recessive and the message is discarded. As a result the sending node will retransmit the original message. |
| EOF | 7 | Is the End of frame bit field that notates the end of the frame. |
| IFS | 7 | the inter-frame space. The inter-frame space is designed to give a controller the necessary time to move a correctly received frame to its destination in the buffer |

Table 3 - Standard Frame Definitions

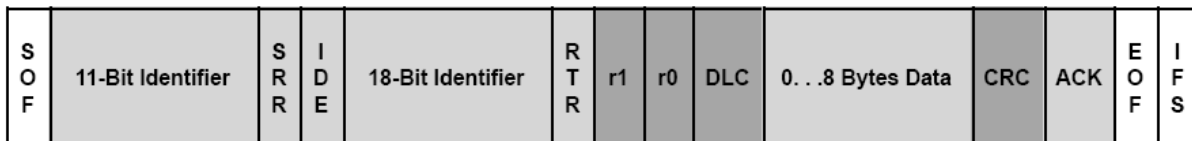

Figure 12 - Extended Frame Breakdown, Texas Instruments, *Introduction to CAN*

| Name | Bits | Definition |
|-------------------|-------------|---|
| SOF | 1 | the Start of Frame bit notates the start of a message. It is also used to synchronize the nodes on a bus when they have been idle. |
| SRR | 1 | the substitute remote request bit, used to place hold where the RTR bit is usually located in the standard message. |
| IDE | 1 | Identifier Extension bit is a recessive bit that will identify the information to be of extended frame. |
| 18 Bit Identifier | 18 | The 18 bit identifier includes the priority of the message. A higher priority message, as previously stated, has a lower binary value. |
| RTR | 1 | remote transmission request bit is dominant in the event that the information is required from another node. |
| R1 | 1 | Reserved bit currently not used |
| R0 | 1 | Reserved bit currently not used |
| DLC | 4 | the Data length code containing the number of bytes of data being transmitted. |
| Data | <64 | the data field |
| CRC | 16 | the cyclic redundancy check, 15 bits and a delimiter. The CRC contains the number of bits being transmitted of the preceding application data for error detection. |
| ACK | 2 | the acknowledgement bit, plus a delimiter, that every node overwrites after successfully receiving an accurate message. The recessive bit is overwritten with a dominant bit if an error free message has been sent. In the event that a node detects an error, the bit is left as recessive and the message is discarded. As a result the sending node will retransmit the original message. |
| EOF | 7 | End of frame bit field that notates the end of the frame |
| IFS | 7 | the inter-frame space. The inter-frame space is designed to give a controller the necessary time to move a correctly received frame to its destination in the buffer. |

Table 4 – Extended Frame Definitions

1.6.4.5 Non-Return-to-Zero

NRZ, Non-Return-to-Zero line code is a transmission method used by CAN where logic '1's are represented by a high voltage and a logic '0' is represented by low voltage. There is no rest condition, with CAN, but bit stuffing is used. ⁸

1.6.4.6 Bit Stuffing

CAN is asynchronous, meaning that it does not require a global clock signal but uses the recovering clock information from the data stream. Here, CAN uses Bit Stuffing. For CAN, Bit Stuffing is the process in which an opposing polarity bit will be put into the data stream if five bits of the same polarity are sent. Used only for synchronization, the bit is disregarded and not used as data. ³

1.6.4.7 Error Detection^{6,7,8}

1.6.4.7.1 CRC Error

The CRC, cyclic redundancy check, is a 15 bit value calculated by the transmitting node, transmitted in the CRC field. The cyclic redundancy check is a way to ensure that all the nodes on the network received the correct message. If the CRC calculated by each node on the network does not the CRC values broadcasted, an Error Frame will be generated and the message will be resent.

1.6.4.7.2 Acknowledge Error

For at least one node to correctly receive a message, an Acknowledge Slot must contain a dominant bit. If the bit is a recessive bit, then the message transmitted was not received by any node correctly. As a result an Error Frame is generated and the message will be resent.

1.6.4.7.3 Form Error

In the case that an End of Frame, Inter-frame Space, Acknowledge Delimiter or CRC Delimiter contains a dominant bit, a Form Error is generated. As a result, the message will be resent.

1.6.4.7.4 Bit Error

A Bit Error will occur in the event that a transmitter sends a dominant bit and a recessive bit is identified. A Bit Error will also take place when a recessive bit is sent and a dominant bit is detected. As a result of the detection, an Error Frame is generated and the message is resent.

1.6.4.7.5 Stuff Error

A Stuff Error occurs in the condition that Bit Stuffing is not properly executed and six bits with the same polarity are transmitted and or detected. An Error Frame is sent and the message is resent.

1.6.4.8 Fault Confinement⁸

According to the severity of an error, CAN nodes are capable of determining fault condition and transition to error states. This process is called Fault Confinement and is implemented to guarantee bandwidth for critical system information.

1.6.4.9 Three CAN Error States^{1,4,5,6,7,8}

In the event that an Error Frame or Error flag is created, the transmission of the message that resulted in the error is terminated. The message will be present when it has the network availability. Below are the three types or error states:

1.6.4.9.1 Error-Active

If a node's Transmit Error Counter and Receiver Error Counter are below 128, it is Error Active. While a node is Error Active, communication with the bus can still take place and an error flag will be sent. An error flag is comprised of six dominant bits violating the Bit Stuffing rule. As a result, every node sends an Error flag. During this process, the Error 'Echo' Flag is sent from all the other nodes in addition to the Error Flag, can send up to twelve consecutive dominant bits.

1.6.4.9.2 Error-Passive

When the Transmit Error Counter (TEC) and Receiver Error Counter (REC) exceed 127 a node becomes Error Passive. Opposite of Error-Active, when a node is Error-Passive, six recessive bits are transmitted as the Error Flag. In the event that the Error-Passive node's message is the only message being sent, acknowledgement of the Bit Stuffing rule violation will be made from the receiving nodes. There is no effect on the bus unless the Error Passive node is the only transmitter.

1.6.4.9.3 Bus -Off

If the Transmit Error Counter is greater than 255, the node will immediately go into the Bus-Off state. Nodes are not able to send, receive or acknowledge messages in this state. Error frames can also not be sent. The justification of the Bus-Off state is to keep the network available for transmission of other important information.

1.6.4.10 Speed and Voltages ⁴

CAN is defined by ISO 11898 or ISO 114519. Data transfer rates range from a maximum of 1Mbps to a minimum of 10kbps. Communication lines used on the OBDII connector are Pin 6 as a high, Pin14 as a low. In addition CAN uses two ground types, Pin 4 as the Chassis Ground, and Pin 5 as the Signal Ground. The two communication lines operate in a differential

| | | | | | | | | | |
|-------------|----------|-----------------|---------|-----|----------------|---------|------|------|-------------|
| mode | Signal | recessive state | | | dominant state | | | unit | where the |
| voltages | | min | nominal | max | min | nominal | max | | carried are |
| inverted to | CAN-High | 2.0 | 2.5 | 3.0 | 2.75 | 3.5 | 4.5 | Volt | decrease |
| noise | CAN-Low | 2.0 | 2.5 | 3.0 | 0.5 | 1.5 | 2.25 | Volt | |

interference. Pin 16 is the voltage of the battery. Below are the standards for the voltage levels for both the ISO 11898 and ISO 11519;

ISO 11898, Bredband.net, *CAN Information*

| Signal | recessive state | | | dominant state | | | unit |
|----------|-----------------|---------|-----|----------------|---------|------|------|
| | min | nominal | max | min | nominal | max | |
| CAN-High | 1.6 | 1.75 | 1.9 | 3.85 | 4.0 | 5.0 | Volt |
| CAN-Low | 3.1 | 3.25 | 3.4 | 0 | 1.0 | 1.15 | Volt |

ISO 11519, Bredband.net, *CAN Information*

The impedance of the cable, a twisted pair of wires, used in the ISO 11898 network is 120 +/- 12ohms. ISO 11898 contains 120ohm termination resistors at the end of each wire while ISO 11519 does not require termination resistors due to the lower bit rates. Bit rates determine the maximum bus length for the network. The bus lengths are limited to all the bit signal to travel and from to every node on the network before the bit is sampled. See table below:

| | |
|---------------------|--------------------------|
| Bus length (meters) | Maximum bit rate (bit/s) |
|---------------------|--------------------------|

| | |
|------|------------|
| 40 | 1 Mbit/s |
| 100 | 500 kbit/s |
| 200 | 250 kbit/s |
| 500 | 125 kbit/s |
| 6 km | 10 kbit/s |

Bus length vs. Maximum bit rate, Breband.net, *CAN Information*

1.6.4.11 Bit Timing

A frame is divided into four segments consisting of one or more time quanta. A time quanta is a time length derived from the CAN controller. The time quanta is a fixed time length and includes a prescale factor. As seen below in Figure XVV, the four segments are comprised of Synchronization, Propagation, Phase 1 and Phase 2. Length of each phase segment is determined by the conditions provided by the network and node under the following conditions; The Synchronization segment is always one quanta in length and synchronizes the nodes on the bus. The Propagation segment is programmable between 1 and 8 quanta to compensate for delay in the bus cables. Both Phase segments 1 and 2 are used for resynchronization. Continuous synchronization is achievable by the sample point found between Phase 1 and Phase 2's buffer segments. Continuous synchronization allows the receiver of the frame to correctly read the message being sent. ^{3,5,8}

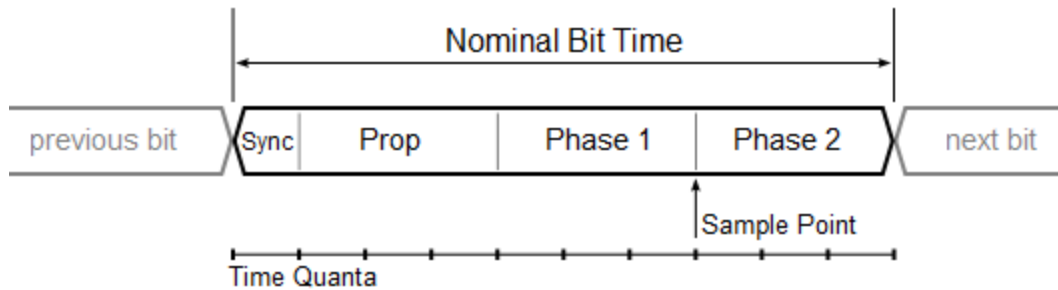

Figure 13 - CAN Bit Timing Diagram, RocketMagnet

Baudrate Calculations

Baudrate, also known as modulation rate, is the number of distinct symbol changes made per unit second in line code or a digital signal. For CAN, the baudrate of the bus is derived from the following equation:

$$\text{Baudrate} = f_{\text{crystal}} / (2 * n * (\text{BRP} + 1))$$

Baudrate Equation, Breband.net, *CAN Information*

Variable BRP is the prescaler factor. Variable 'n' is the number of time quanta in one bit derived from the equation; $n = \text{SYNCHSEG} + \text{Phase1} + \text{Phase2}$. The Sample point is usually derived from the percent of the bit time between the Quanta before the sampling point and the quanta after the sampling point; $(\text{Phase1} + 1) / (\text{Phase1} + 1 + \text{Phase2})$.

Resynchronization is a fashion to compensate for bus delays and nodes of different crystal frequencies. There are two types of resynchronization, Hard and within a frame. Hard resynchronization is used to as the bus leaves the idle stage after detecting a starting bit. It will be resynchronized on its own to place the edge inside the synchronization segment. Within a frame CAN controllers use SJW, a Synchronization Jump Width to determine the maximum number of quanta the controller can resynchronize each bit. ¹

1.6.4.12 Network Structure

An example Controller Area Network may be seen below in Figure 14. There are a multitude of devices such as emissions, safety, control devices, and many others. Each device communicates with a host processor via a CAN Controller connected to the bus.

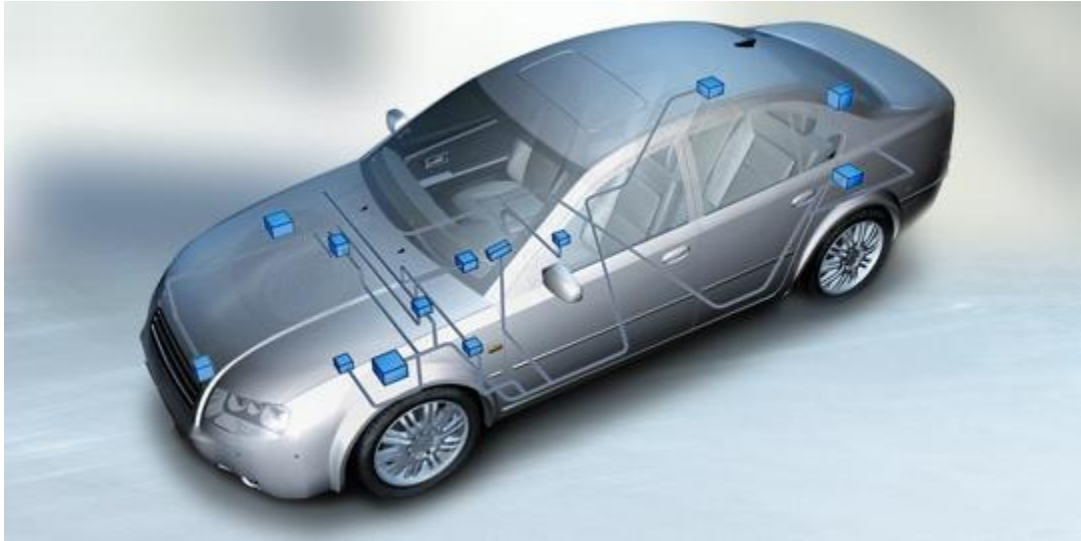

Figure 14 - CAN Network in Practice

1.6.4.13 Node Structure

Nodes are composed of a host processor, a CAN controller, and a transceiver. In a node, the host processor will derive received messages and will calculate what messages to transmit. The CAN Controller is the primary means of sending and receiving messages within a node. To send, once the host processor has completely stored the desired message to be transmitted into the CAN Controller, transition will commence in the form of bits serially onto the bus. To receive, the CAN Controller serially stores bits and is available if the message pertains to the host processors request. A CAN Controller has a synchronous clock. The final part of the node structure is a Transceiver often built into the CAN Controller. The Transceiver translates transmitted and received messages to and from the bus and the controller respectively. While receiving, the Transceiver will adjust the signal levels from the bus to those the CAN Controller can process.

While sending, the Transceiver takes converts the signal provided by the CAN Controller to that of which the bus requires. In addition to the Transceiver's receiving and sending capabilities, it also provides the CAN Controller with a buffer protective circuitry layer.³

1.6.4.14 Node Application

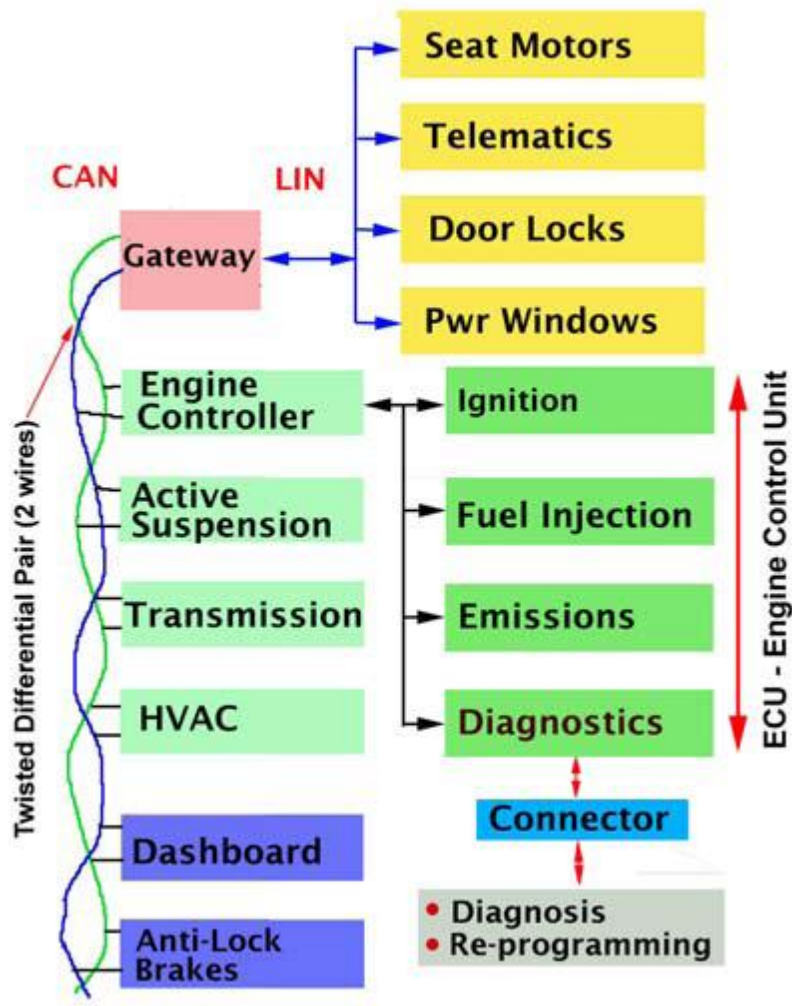

A Vehicle Network and its Components, DGTech.com, *Controller Area Network*

The figure above connects a Controller Area Network bus with a Local Interconnect Network bus by a gateway located within one of the Electronic Control Modules of the vehicle most often in the Engine Control Unit. The Engine Control Unit is where the vital engine control functions are located and is a clearinghouse for the vehicle's diagnostics in this case, OBDII.²

2 Project Definition

2.1 Understanding Possible Target Markets

Interviewing mechanics and employees of local consumer auto parts stores proved to be valuable in identifying a problem that there is inefficiency in the way OBD-II codes are transmitted from the car to the professional. This inefficiency can be eliminated with a product which removed the most important part of the OBD-II scan tool from the untrained user's custody.

2.1.1 AutoZone

One of the possible customers that were identified was AutoZone. AutoZone is a consumer automotive parts store that sells a multitude of products to end consumers. Founded in 1979, AutoZone is a multi-country, public company that offers consumer auto parts. Consumers can visit a store and have their car scanned for OBDII codes, which helps in the diagnosis of what the customer needs to buy.

The inherent problem with allowing customers to "borrow" a scan tool is that the scan tool is not always returned. Further, the scan tool can be mishandled by untrained customers and come back in a worse condition. Over time, the scan tool will be used to the point that the unit will break from the wear and tear of untrained users. Therein lays a problem where the use of the

scan tool by untrained users causes a loss in the assets of a particular company, in this case, AutoZone.

The product which this MQP team intends to create will solve the problem of asset loss, and help keep the most important parts of a scan tool in the hands of the professionals. The base unit, which accepts, reformats, and transmits through either a USB cord or to the regular scan tool. The unit sent with the customer, however, is a unit which transmits the codes directly only and does no calculation or reporting.

Having a setup this way would help AutoZone in that they will no longer have to send a professional staff member with consumers to plug the unit into their cars. Giving the unit to the consumer and instructing them on where to place the plug is the only work that needs to happen. The unit instructs the user when the signals are complete, and can remove the unit. Once these instructions are given, the user unplugs the unit, and walks back into the AutoZone shop. The attendant has already seen the codes and has the ability to print out product listings and instructions for the customer.

This increases the store's revenue and frees up man hours for the staff, which allows the AutoZone to do better staffing, and better business. AutoZone would benefit both financially and operationally from the use of this product.

2.1.2 Emissions Testing Garages

A second possible customer is identified as the Automotive Inspection Bays throughout the United States. With over 230 million vehicles on the road in the US, Automotive Bays have continuously run inspection tests on vehicles since 1996. Comprised within the inspection testing are three major sub-tests; Visual, Safety and Emissions inspection. Safety and Visual inspections are serious parts of the overall test, but the focus of our product is on the emissions. A certified technician will connect a male OBDII connector from the state regulated machine, such as The SPX Corporation Emission Analyzer, directly to the vehicle's female OBDII connector. The vehicle's female OBDII connector is connected to the vehicle's internal computer. The internal computer holds the information on how the vehicle's engine and emissions controls have been operating. The technician will then download the data from the vehicle into his or hers computer. If the data received will be inform the technician if the vehicle passes the emissions test.

According to the technicians that were interviewed for market research on this product, inspections may take anywhere between 15 and 30 minutes per vehicle. Often times customers are lost due to waiting time on the availability of the testing equipment. As a result, each technician explained how vehicle efficiency could greatly be increased with the use of wireless connections, and the possibility of having information readily available to transfer from the vehicles for emissions testing.

A simple connection with the wireless connector alone would allow the location of the vehicle to not be mandated. Moving vehicles around, being restricted to a minimum distance from the machine takes up time. Bottom line, time is money. The faster the test can correctly be completed the more money per hour the Inspection Bay will make.

Advanced to the next stage, the process can become an assembly line with the introduction of the multi-vehicle wireless connections. In the event that there are only a few days left in the month, every month, Automotive Inspection Bays receive a major positive spike in the number of vehicles being tested. This is partly due to the Citation issued by the state for a moving vehicle infraction. An outdated inspection sticker is a \$50 fine with a direct result on personal driver's insurance. On like examples, multiple vehicles will be in line to be tested and the assembly line may be introduced. In example, as one technician focuses on visual inspection and inserting an identifiable wireless connection in each vehicle another technician can quickly go through and run them individually through the computer. As a result, production is increased and profit increases.

2.2 Customer Requirements

The following customer requirements were generated from the interviews with the target market. Mechanics from local automotive shops, attendants at inspection bays, and employees at consumer automotive part stores were interviewed in this subset of the target market for this product. The list is as follows.

- Durable & Sturdy
- Informative
- Parking lot distance wireless capability
- Easy to use
- Comparable price to wired units
- Fit current architecture

2.3 Product Specifications

The following product specifications are derived from the appropriate customer requirements. Each Product Specification is identified in direct result to satisfy a Customer Requirement.

- 1 The system passes all data sent from OBD-II port connected to the Mobile Wireless Unit to the Base Station Unit, connected to a scan tool.
- 2 The system must be able to function without any problems under normal working conditions. Normal working conditions include exposure to dust, dirt, and a frequency of usage which ranges between 5 to 30 times per day
- 3 The Base Station Unit must inform the user that it is connected with a Mobile Wireless Unit correctly or incorrectly. As a result, the user must know if he or she is able to send and receive data through the Base Station Unit to communicate with the OBD-II data port on the automobile outside.
- 4 The unit functions at a range of up to 100 feet
- 5 The system is simple enough to require no user interaction to ensure proper function. The Mobile Wireless Unit only needs to be connected correctly to the OBD-II port on an automobile, and the Base Station Unit to an OBD-II scan tool.
- 6 Unit is compatible with protocols J1850 VPW, J1850 PWM, ISO 9141-2, and Automotive CAN.

3 Product Design

3.1 System Flow

The theoretical unit designed and created in this document is comprised of multiple parts. There is a mobile, wireless unit which is taken to the vehicle, and there is a base station which is not designed to move very far or travel very often.

3.1.1 Mobile Wireless Unit

The Mobile Wireless Unit (MWU) is designed to be transported by hand from the base station's area and brought directly to the OBD-II code source, usually a consumer automobile. The user plugs the unit into the female adapter of the automobile's OBD-II port.

3.1.1.1 Mobile Wireless Unit Block Diagram

The Mobile Wireless Unit will have the components laid out in such a way that it can interface with all types of OBD-II protocols. The block diagram is shown in Figure 15.

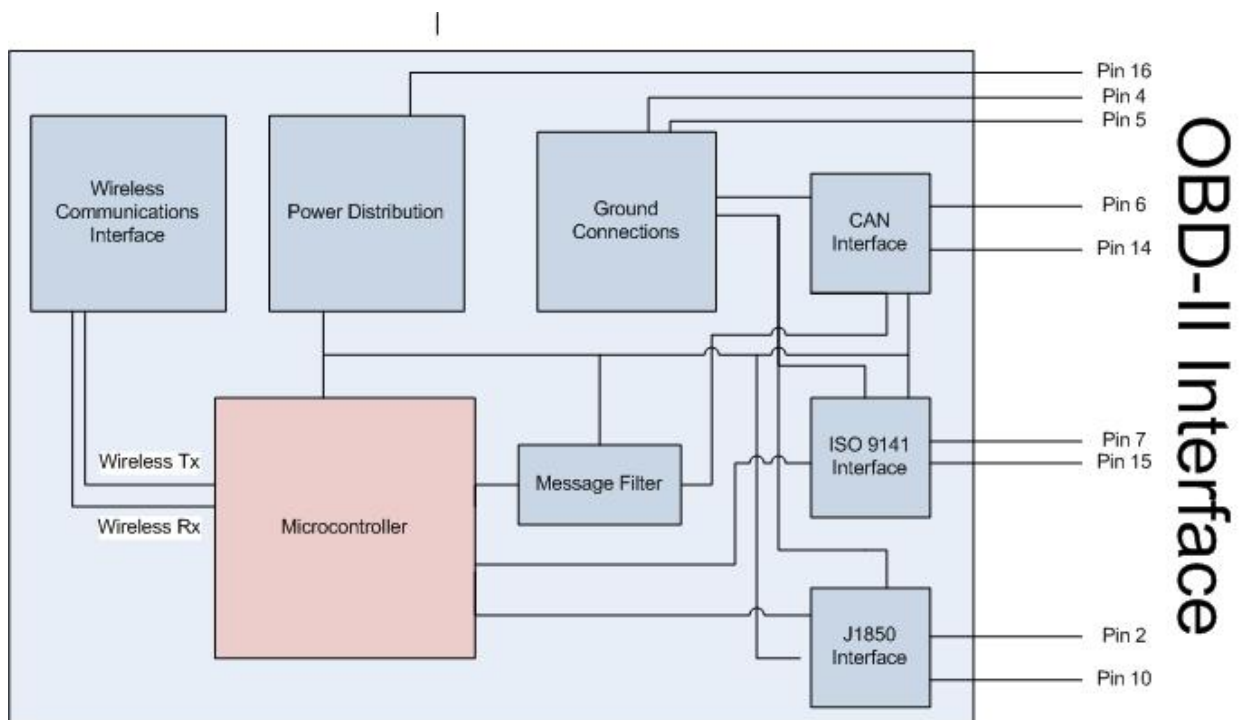

Figure 15 - Mobile Wireless Unit Block Diagram

The block diagram will further be broken into its subcomponents. There needs to be a wireless communications interface which communicates with another mesh network node. This wireless

communications interface would further interface with the microprocessor in the MWU. As more is understood about the signals produced by and through OBD-II standards, a filter will be created to interface with the specific protocol used in the vehicle in question.

With all of the above information being true, a final block diagram is created to display the actual setup for the Mobile Wireless Unit.

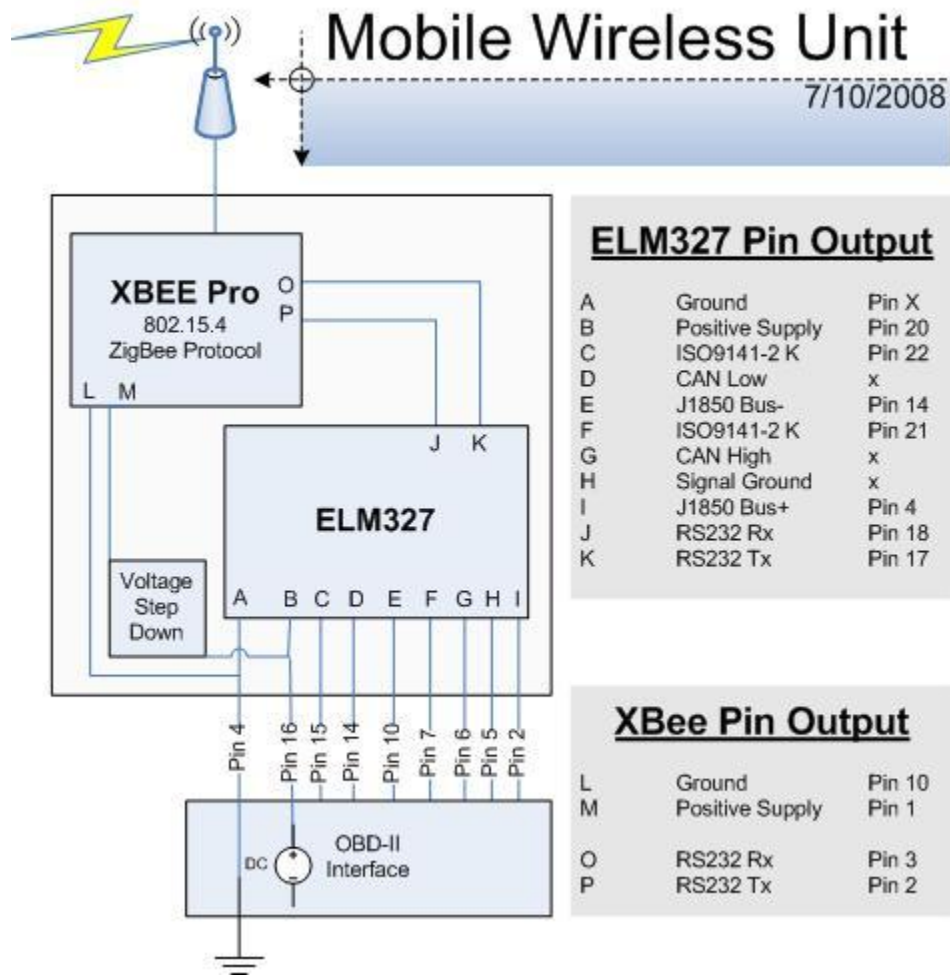

Figure 16 - Mobile Wireless Unit Final Block Diagram

The ELM327 has taken the place of the interface for J1850, ISO9141-2, and CAN OBD-II protocols. This is a proprietary product that is based on the PIC microprocessor

The block diagram is simplified into a series of step up transistors, step-down transistors, resistors, voltage dividers, and the ELM. With these in place, the Mobile Wireless Unit is an eloquent solution to a complex problem. This project team is now able to interface with the vehicle's OBD-II port, regardless of protocol, using RS232 signals.

This is truly a breakthrough in the project, as it allows a communications standard to interface with another communications standard. While the chip may be a bit more expensive than that of an internally developed solution, it allows this team to get to the market faster, and once the product is in the market, the team will search for second generation alternatives to implementation techniques, including but not limited to, the designing of a new system to exclude the ELM327 chip.

3.1.1.2 Mobile Wireless Unit Use

The Mobile Wireless Unit will connect to a female J1962 16 pin connector, communicate with the major OBDII and CAN forms and transmit wirelessly the RS232 Codes to the receiver. The figure below represents the block diagram of the Mobile Wireless Unit.

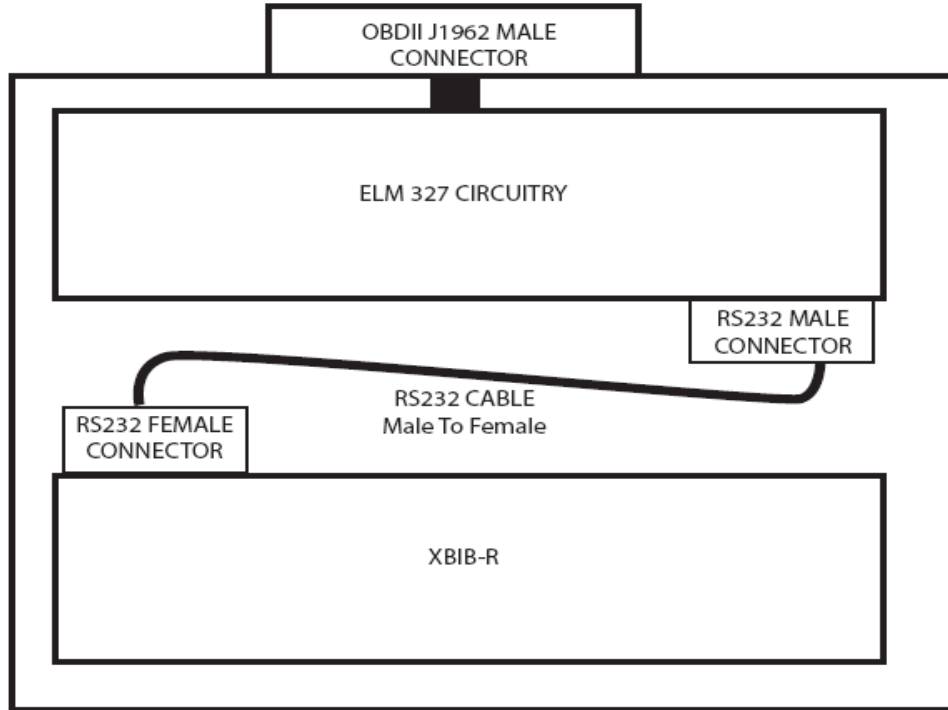

Figure 17 - Mobile Wireless Unit Block Diagram

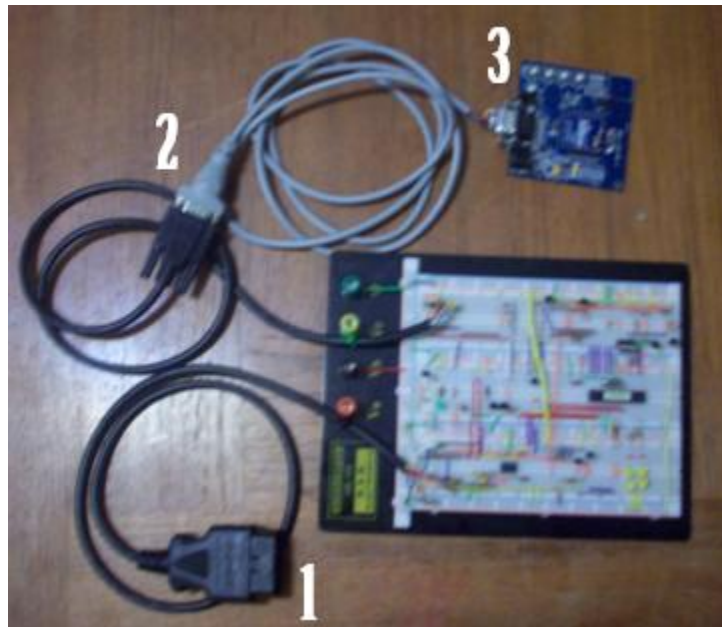

Figure 18 - Mobile Wireless Unit

To begin the connection of the Mobile Wireless Unit, MWU, the user puts the automobile in a state which will cause the automobile to deliver OBD-II codes. This method is completed

differently for each protocol and automobile, and is not standard. Often known as ‘key on engine off,’ the key inserted and turned to the position prior to starting the vehicle. Located on the lower dash panel of the driver’s side of the vehicle a J1962 female 16 pin connector is required by the OBDII standard and will be the interface for communication with the MWU. The user must now connect the male J1962 16 pin connector, seen bellow in Figure 902, to the female J1962 connector.

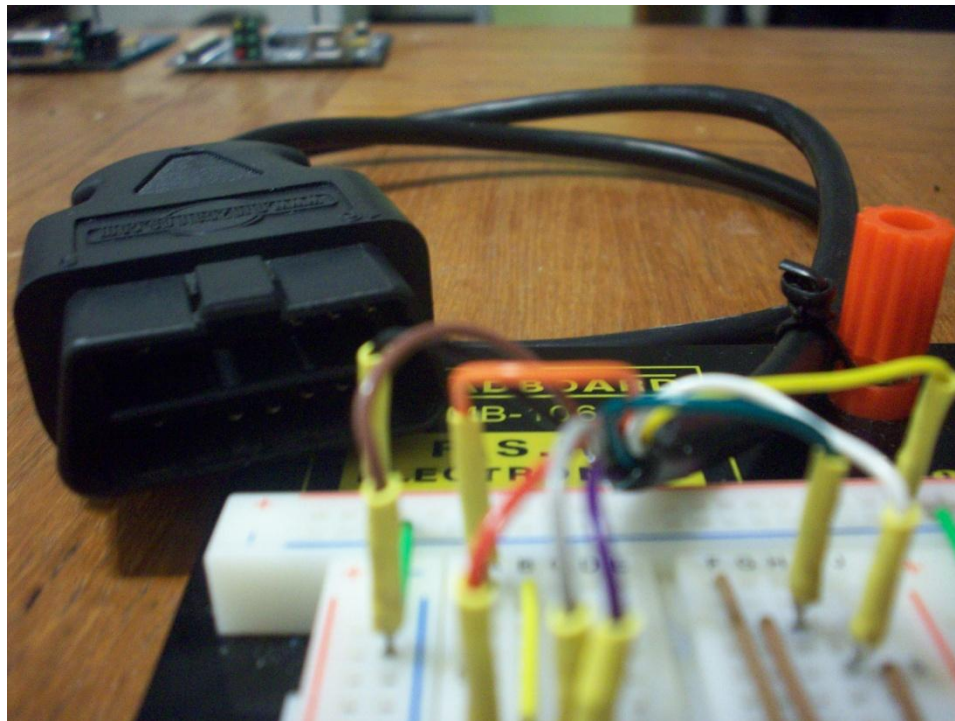

Figure 19 - Male J1962 Connector

The Mobile Wireless Unit runs off of the voltage which is supplied by the automobile’s battery, on Pin 16 of the J1962 female connector. The ground is also provided by the automobile via pin 4, the chassis ground, and pin 5, the signal ground. Voltage is stepped down by the voltage regulator ‘LM78L05 Series 3-Terminal Positive Regulator’ to 5 volts with a $\pm 5\%$

tolerance. Featured below in Figure 903a is the LM78L05 from National.com used in the circuit shown in Figure 903b below.

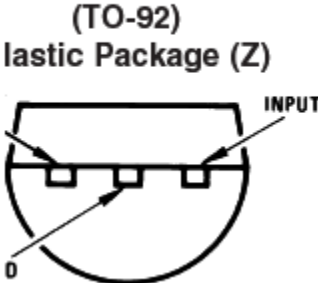

Figure 20 - National.com TO-92 Package

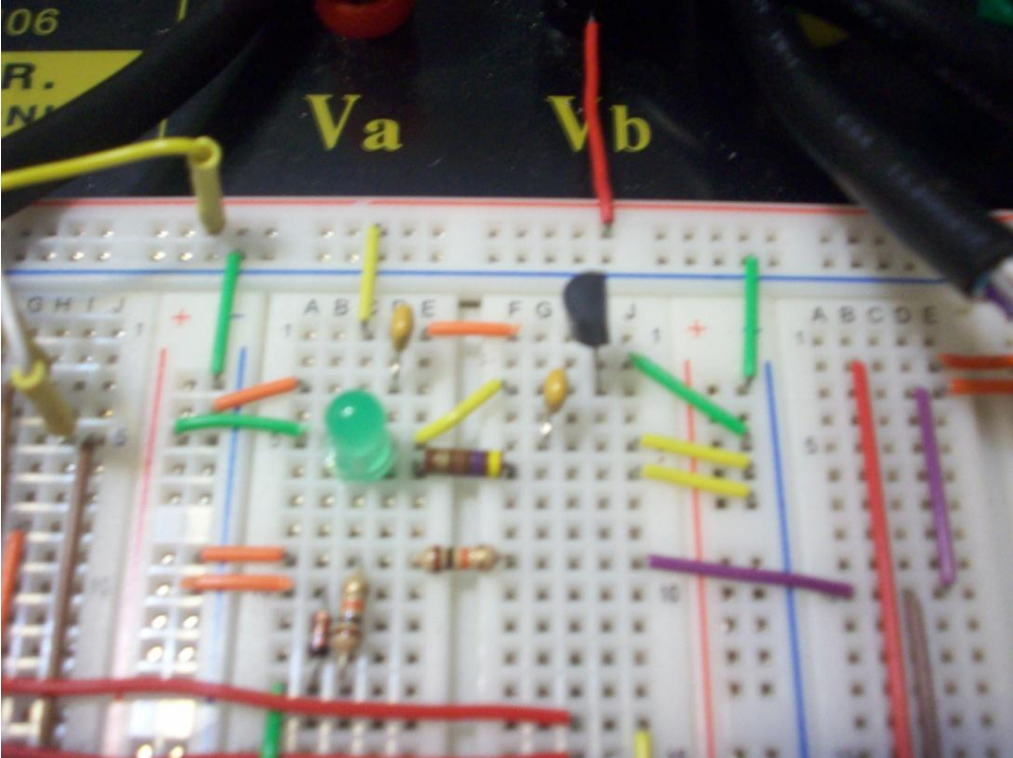

Figure 21 – Voltage Regulation

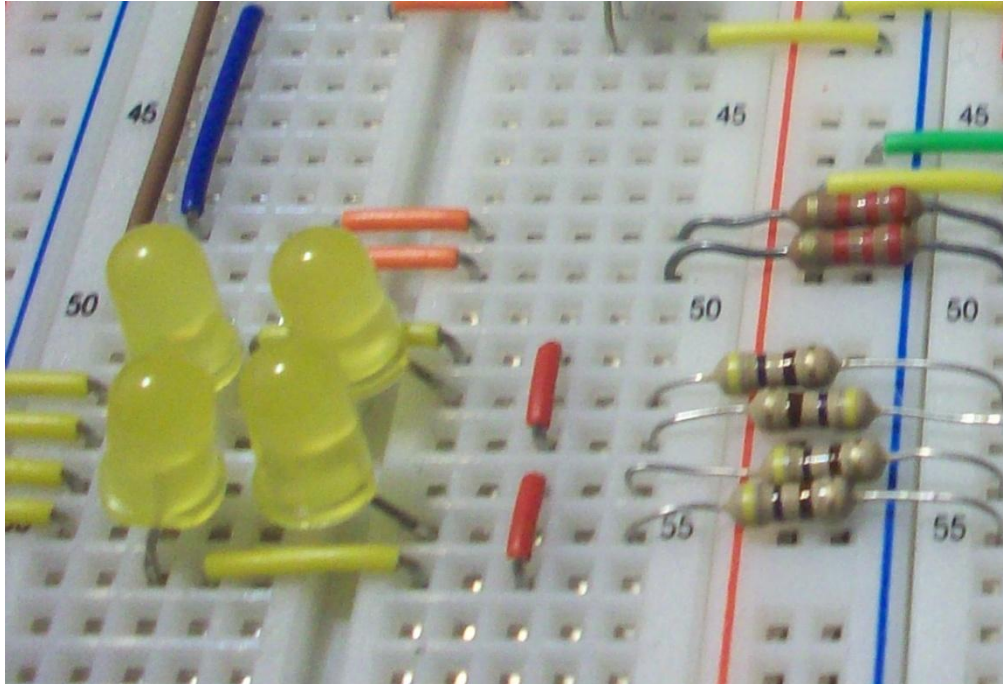

Figure 22 - Proper Connection and Operation Detected

If the MWU is properly connected, these four yellow LEDs shown in Figure 904 will light in a clockwise sequence from bottom right to bottom right. The top left yellow LED represents the Tx, transmit, LED. Upon successful connection this LED will blink once more in after the clockwise sequence. This lets the user know that the board is connected correctly and sends the message “ELM327 v1.2a.” shown below. In addition, the green LED shown in Figure 903 will remain illuminated as long as there is power from the automobile. The circuitry shown below in Figure 905 is compiled of the ELM327 microprocessor, the MCP2551, voltage regulators, resistors, transistors, LEDs, capacitors, a 4.000MHz crystal, diodes, the J1962 male connector and the RS232 Connector.

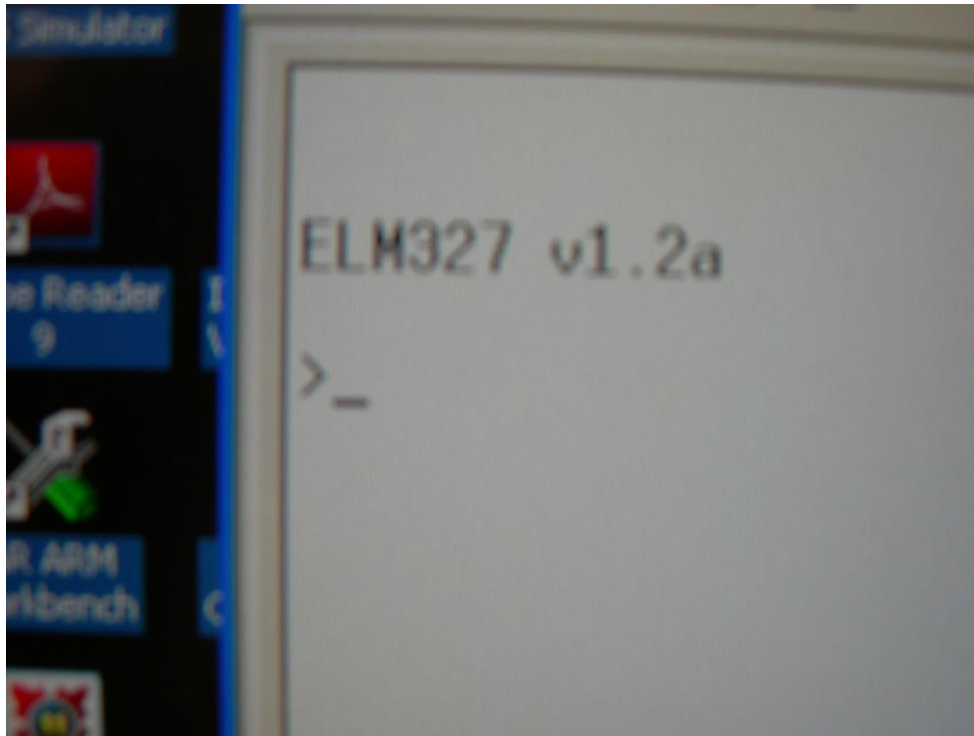

Figure 23 - Initial ELM327 v1.2a Message on HyperTerminal

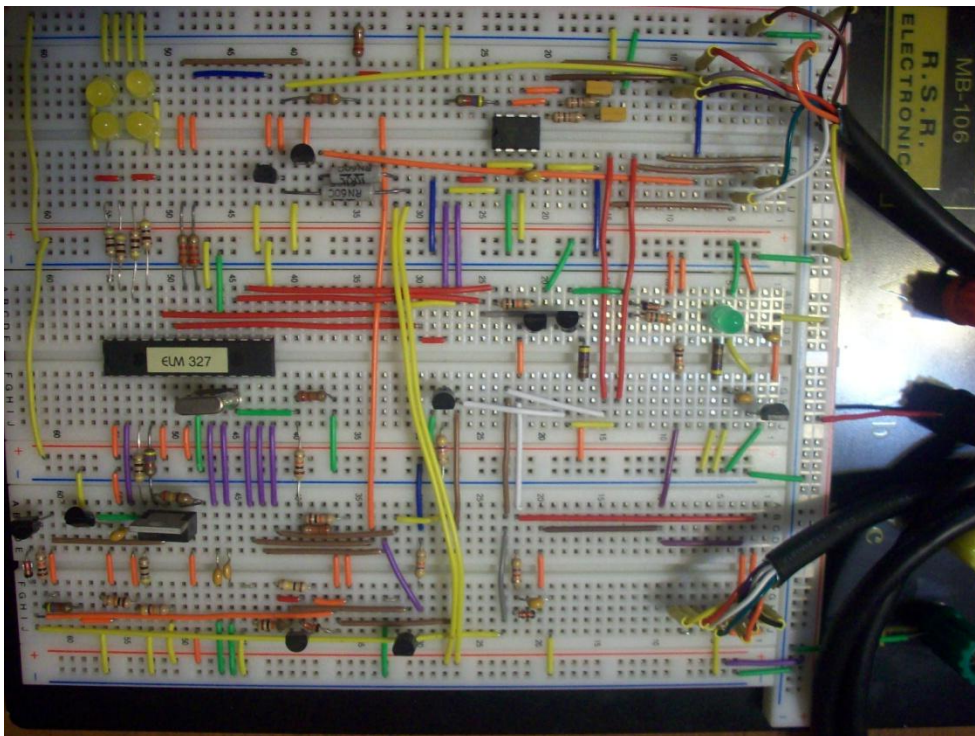

Figure 24 - Breadboard Overhead Shot

4.

The ELM327 is a 28 pin microprocessor that supports 12 protocols, automatically identifies the protocol, is a low power CMOS design, and communicates via RS232 with the ability to be configured using AT commands. As described earlier in this paper is the Controller Area Network protocol, the newest and most prevalent of the OBDII protocols. The ELM327 communicates to vehicles with CAN directly through a high speed CAN transceiver, the MCP2551. This transceiver is ideal due to its features including 1Mb/s capabilities, low current standby operation, power on reset, circuit protection to high-voltages, temperature, ground fault and more. The MCP2551 connects to pin 14, CAN High, of the J1962 male connector via pin 6 of the integrated circuit. In addition, the MCP2551 connects to pin 6, CAN Low, of the J1962 male connector via pin 7. The ELM327 initiates communication with the MCP2551 when CAN is detected using the transmitting, Tx, and receiving pins, Rx, pins 23 and 24 respectively. The MCP2551 connects to the ELM327 via pin 1, for Tx, and pin 4, for Rx.

Pin 25 of the ELM327 is connected to one of the four yellow LEDs shown above in Figure 904 and 905, during RS232 Rx communication, this LED will blink. Likewise, pins 26, 27 and 28 are each connected to a yellow LED for RS232 Tx, OBD Rx and OBD Tx respectively.

Communication between the ELM327 and a vehicle with the ISO protocol, is through pin 21 of the ELM327 to pin 7, of the J1962 male connector ISO-K, and pin 22 of the ELM327 to pin 15 of the J1962 male connector, ISO-L. Pin 12 of the ELM327 is also connected to pin 7 of the J1962 for other forms of the ISO standard. To protect the ELM327, Resistors and transistors are placed in series between the J1962 male connector and the ELM327.

J1850 protocols communicate with the ELM327 via pins 10, J1850 bus negative, and 2, J1850 bus positive, of the J1962 male connector and pins 3, 4, 11, 13, and 14 of the ELM327. Pin 3 of the ELM327 controls the voltage supplied if necessary between 5volts and 8volts. Pin 4 of the ELM327 drives the positive J1850 bus line connected to pin 2 of the J1962 to an active high. Pin 11 of the ELM327 is for the VPW high input for J1962. Pin 13 and 14 of the ELM327 are used for the Pulse Width J1850 low input and to drive the negative J1850 bus line respectively.

The Mobile Wireless Unit is powered, readily available to communicate with the 12 protocols, and ready to transmit information the corresponding data. To transmit the data, the ELM327 uses pin 17 to transmit RS232 data and pin 18 to receive. As shown in figure 906 below these pins connect to pin 2, RS232 Tx, and 3, RS232 Rx, of a DB9F cable. The DB9F cable is also connected to a signal ground via pin 5 and shorted together via pin 1, 4, and 6 along as is pin 7 and 8.

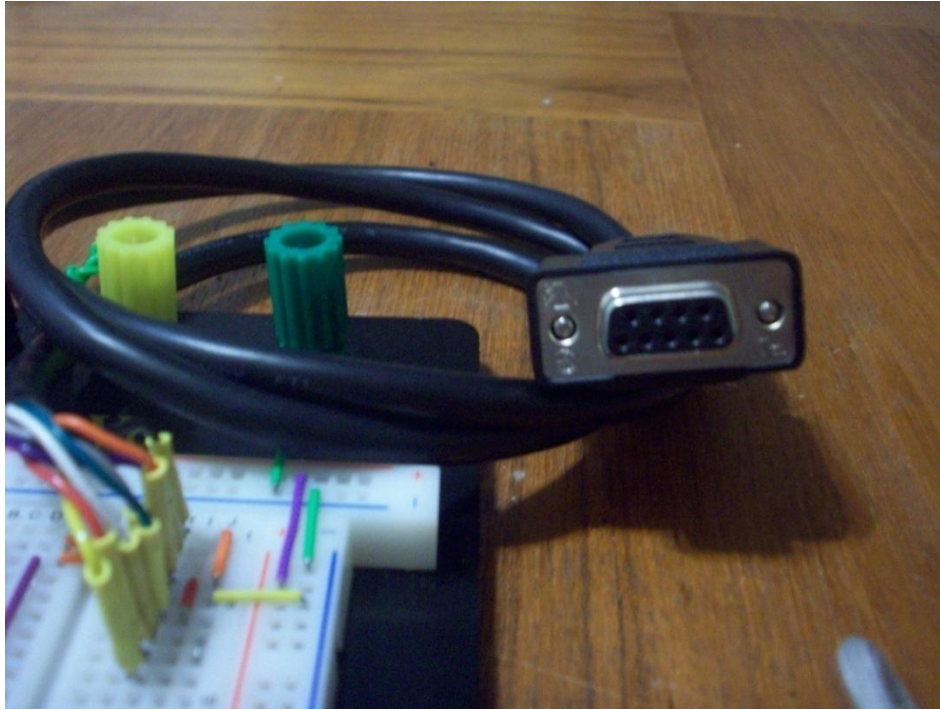

Figure 25 - RS232 DB9F Connector/Cable

The figure below demonstrates the connection of the RS232 cable and the XBee used for wireless transmission.



Figure 26 - XBeePRO MWU

Communication can be made both wirelessly and wired. A wired connection can be made using a standard personal computer, PC, with a serial DB9 port and connecting an RS232 cable directly from the MWU without the Xbees. A wireless connection can be made in conjunction with the 2 Xbee boards and a USB cable to a computer with USB ports. The platform used to send and receive data is a standard HyperTerminal that comes in most PCs. With this, the baud rate can be set to the needed 9600 baud and the appropriate communication port selected. With the connection made between the PC and the MWU, the male J1962 connector may be plugged into the vehicles female J1962 port and the first message as described and shown above is 'ELM327 v1.2a.' displayed in the HyperTerminal. On the second line will be the ELM327 prompt character '>.' The MWU is ready to receive characters from the HyperTerminal and begin use. These character commands can be found in the Elm Electronics ELM327 appendices attached to this paper.

3.1.2 Base Station Unit

The Base Station Unit, or BSU, sends and receives information to and with the Mobile Wireless Unit. The BSU is always in a state waiting for a connection request. Once the Base Station Unit detects a request to connect from a Mobile Wireless Unit, a handshaking process occurs between the units.

Upon a successful connection handshaking process, the Mobile Wireless Unit transmits data to and from the Base Station Unit. The Base Station Unit has the functionality to pass data

immediately through to an existing OBD-II Scan Tool, and has the hardware required to connect through USB to any peripheral device which can connect to USB.

The BSU should have the ability to connect multiple Mobile Wireless Units simultaneously, so that the limitation of a one-to-one ratio of connectors to scanners is eliminated. A block diagram of the Base Station Unit is shown below in Figure 27.

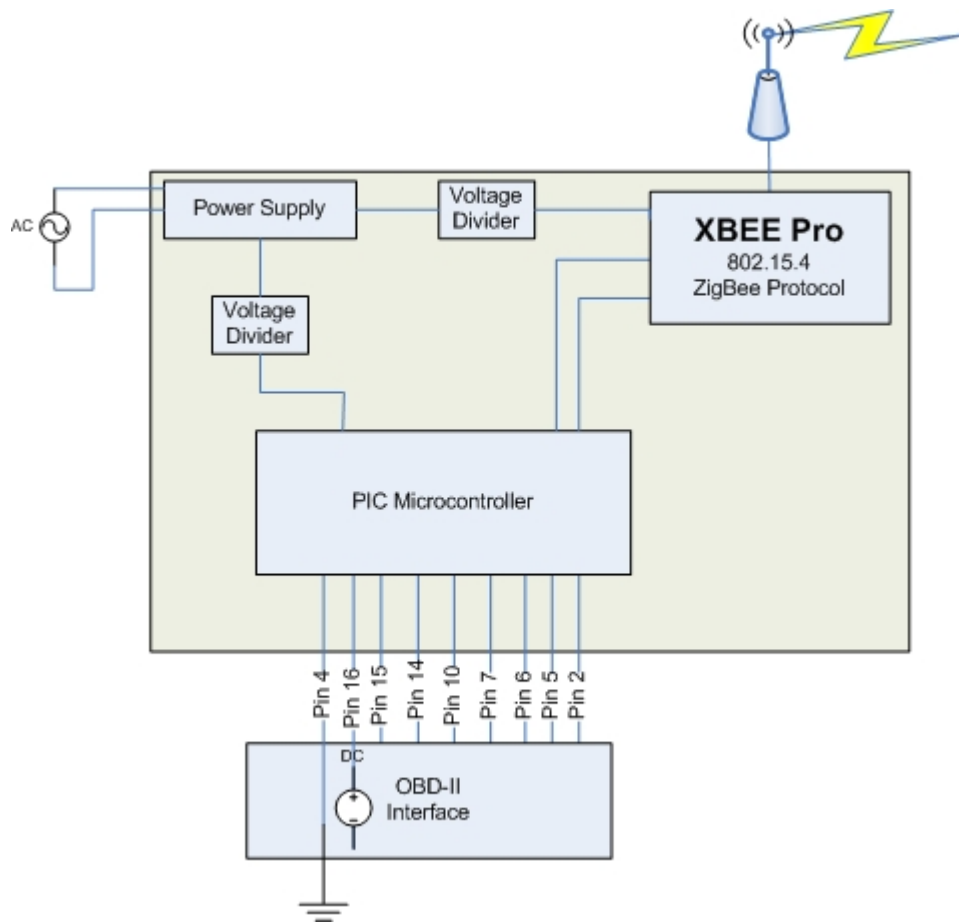

Figure 27 - Base Station Unit Block Diagram

With this identified, the members of this project team can begin work on creating this part of the project, which involves two interfaces.

3.1.2.1 Pass-Through Functionality

Initially the BSU is set up to only pass through data which is being sent through the wireless connection. The data is accepted from the Mobile Wireless Unit, the BSU then sets the voltage of each corresponding OBD-II pin to match the data being sent from the Mobile Wireless Unit. This is the functionality which is implemented in the completion of this project.

3.2.1.1 USB Connectivity

The BSU should have the ability to collect data from multiple Mobile Wireless Units simultaneously and transfer this information in real time to a computer connected through USB. This functionality opens the door to an unbelievable amount of extended features. Services could be created which would enrich the use of this product solution.

Possible additional services include monthly updates with new automobile support, computer program upgrades and support, mass data storage, and other online services which may be identified at a later date.

3.2 System Block Diagram

The Mobile Wireless Unit transmits information wirelessly to the Base Station Unit. The Base Station Unit also has transmission capability with the Mobile Wireless Unit. As these units transmit data between themselves, data must also be sent and received from peripheral devices to make this product useful to a consumer. The BSU has a female OBD-II adapter as part of its architecture, and allows the end user to interface with the automobile's OBD-II port from a sheltered, remote location. The OBD-II female port on the BSU is virtually the same port as that

to which the Mobile Wireless Unit is plugged. Figure 28 illustrates a high level block diagram of the final functioning system.

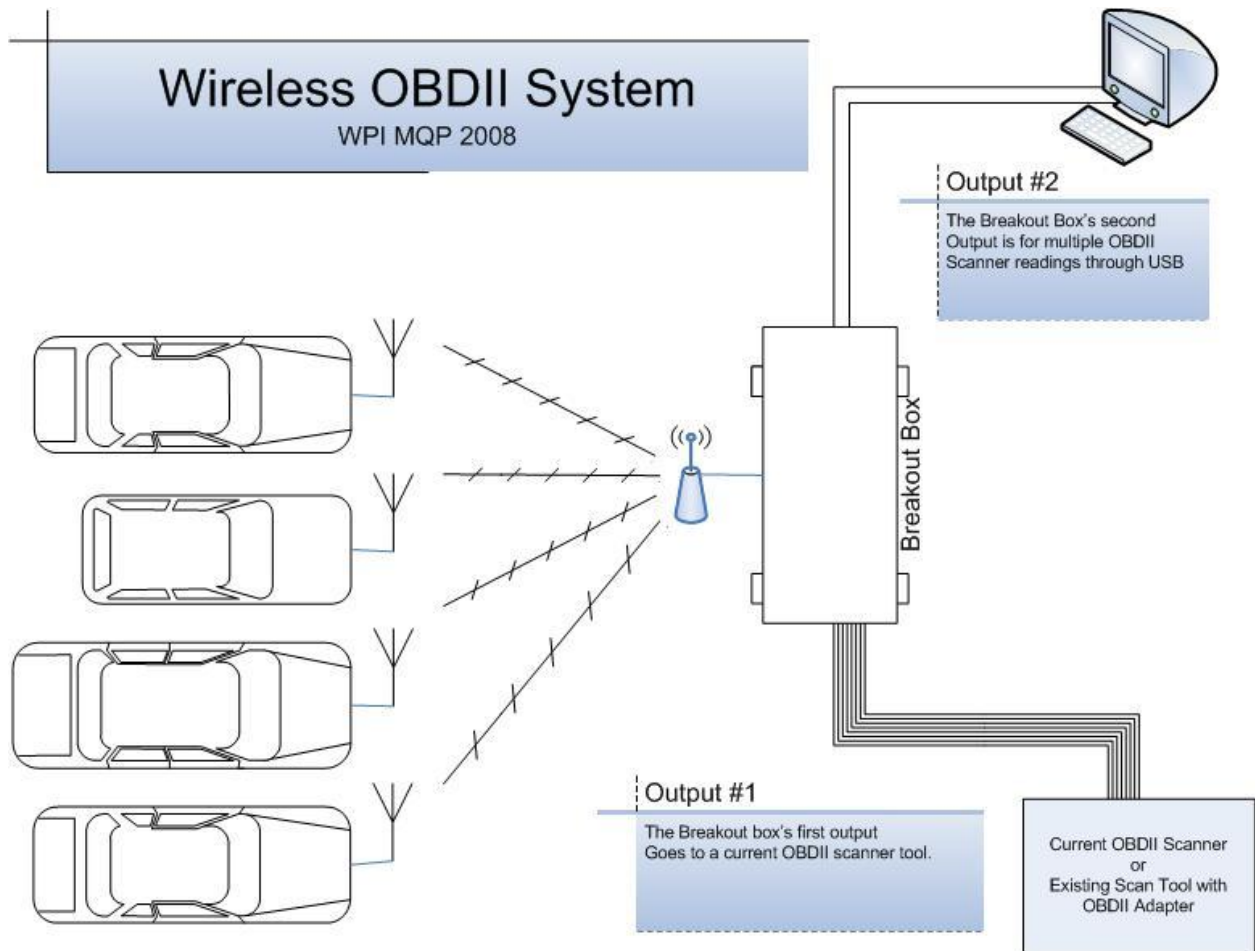

Figure 28 - System Block Diagram

3.3 Hardware Assembly

3.3.1 Final Hardware Purchase List

The system block diagram, Figure 28, displays wireless components working with microprocessor components. These components are built around OBD-II connectors, both male

and female, and have simple interfaces to each other. A hardware list has been identified for the initial development of this system.

- XBee-PRO Development Kit
- Arduino Development Kit
- Rabbit Semiconductor Development Kit
- USB Development Board

The above hardware sets were available through online resources directly from manufacturers.

3.3.1.1 XBee-PRO Development Kit

For the purposes of this project, the team has chosen to use RS232 to communicate among interfaces involved with the Mobile Wireless Unit and the Base Station Unit, and further a computer receiver or a commercial scan-tool. It became increasingly important to choose a medium of wireless communication that understood and replicated RS232 signals. The research completed led the team to the use of the XBee-PRO.

The XBee-PRO is a wireless communication platform created by Digi. The platform allows the communication of RS232 signals without the in-depth knowledge required to program difficult to use other wireless protocols. The XBee-PRO utilizes the ZigBee protocol, which is a mesh-network protocol created for close-proximity nodes in a network. An example of proposed ZigBee use includes home automation, where one node can communicate with another.

For example, while at work, a person can send a command through the internet to have his or her stove, which had been refrigerating a turkey, to change temperatures to defrost, or even begin to

cook the turkey, so that travel time can be used effectively, and dinner for the family would be ready at a more convenient time.

Another example of ZigBee's proposed use is that of traffic engineering. Each car would be equipped with this relatively inexpensive product, and a mesh network would be created. Information about the car's speed, and data about a driver's tendency to change lanes and acceleration data can all be collected for future reference of developing better traffic flow control.

As a relatively new technology, this MQP team believed that it was the best option for the purpose of wirelessly communicating OBD-II data between the MWU and the BSU. This puts the MQP team right in line with emerging technologies, and allows this project to function using products at a discount. We were able to obtain a few chips at relatively low-cost, and were able to prove the concept of wirelessly communicating utilizing this protocol at a reasonable price. Thankfully, this technology ended up being a great solution and we are happy with the decision to move forward with the XBee PRO.

3.3.1.2 Arduino Microprocessor Development Kit

The Arduino Development Board includes the Atmega168 microprocessor on its board.

There is a large sized following for people on the internet who use this architecture for all types of applications. The team felt that this board would best suit the needs of this project, and would interface nicely with the ZigBee-PRO wireless circuits.

Figure 29 shows the Pin Mapping for the Arduino board. The black, inner text is used to identify the function for which the microprocessor uses, and the outer red text is used to show for what function the Arduino uses the pin.

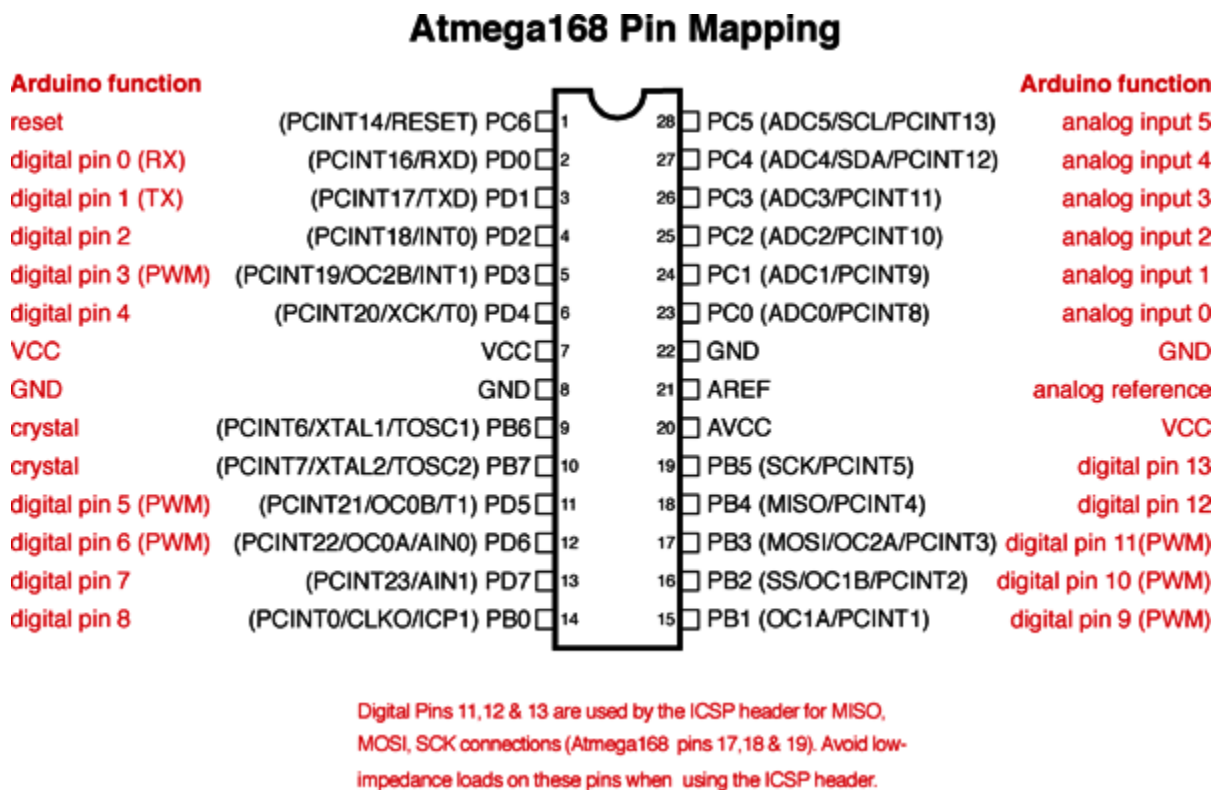

4 Figure 29 - Arduino Pin Configuration⁹

⁹ Arduino – Atmega168Hardware: <http://www.arduino.cc/en/Hacking/Atmega168Hardware>

Understanding this pin configuration became increasingly important as the project continued, as the chip would often have to be removed from the Arduino environment to ensure that the digital state of the pin was correct, and that the predictive nature of microprocessors were correct.

Lastly, the PWM pins used in the software implementation were simply digital pins which were changed with an internal function. This project had to rewrite the code to ensure that the PWM signals were being generated utilizing hardware interfaces instead of software digitalWrite commands.

4.1.1.1 Printed Circuit Board Development

A Printed Circuit Board, PCB, is a board that electronic components are placed on and connected using traces. Traces act as the wires that connect the electronic components. Etching is a process in which the traces are created. A board covered in a metal, such as aluminum or copper, will be ‘masked.’ Masking is covering the areas of the board that are to remain after etching. When the desired traces are masked out, the unwanted metal on the board will be dissolved by using chemicals or acids such as sodium hydroxide or nitric acids.

Designing a PCB

The first step in designing a PCB is to layout the board using National Instruments’ MultiSim 10.0. This program offers the designer a comfortable and easy to use platform to simulate, design and validate PCBs. The MultiSim file featured below features traces, components, rails, and nets.

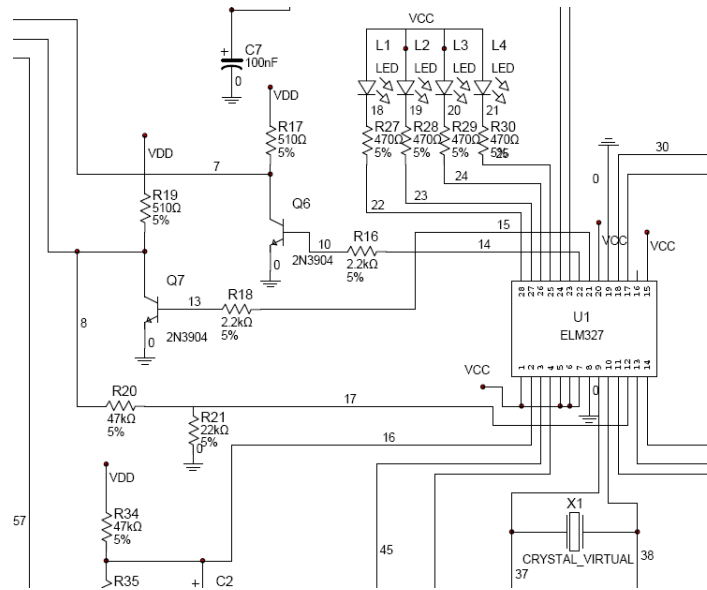

Figure 30 - MultiSim Section

Upon completion in MultiSim, the file was transferred into UltiBoard. Here the components were laid out in a fashion for easy trouble shooting if there were any errors in the design. On one end of the board lies the DB9 connector and on the other the J1962 connector with wire. Throughout the duration of the project many adjustments were made to the design and using the “forward annotation” tool in MultiSim, design was completed in UltiBoard. A few precautionary procedures were made before sending to be manufactured. Connectivity Check was successful as well as the Design Rule Checks. Everything checked out okay. Below is the 3 dimensional view of the board in UltiBoard.

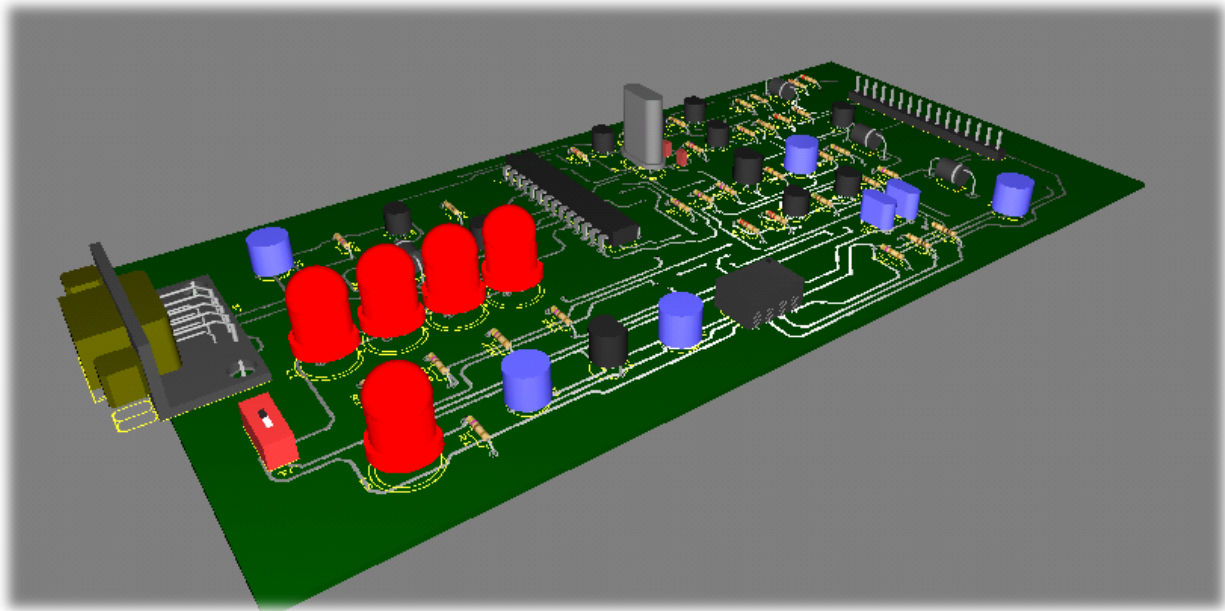

Figure 31 - UltiBoard 3D Board

Featured below is the final board manufactured by Advanced Circuits, found on the internet at www.4pcb.com.

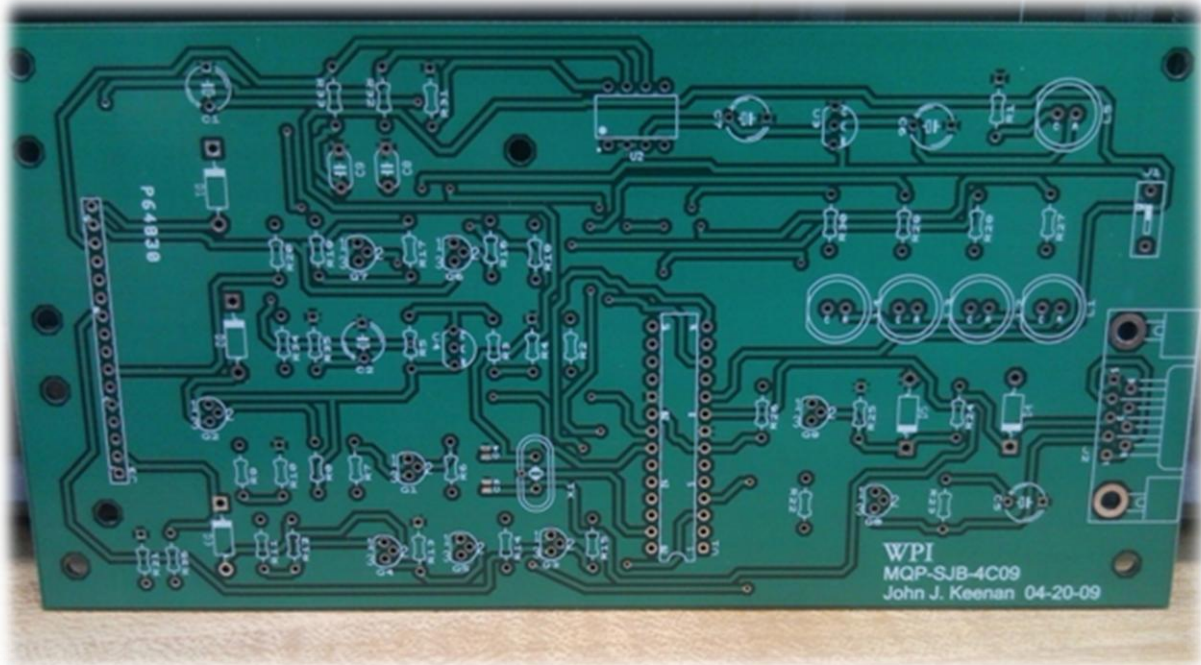

Figure 32 - Manufactured PCB

4.1.2 Identification of Interfaces

4.1.2.1 Mobile Wireless Unit Interfaces

The ZigBee-PRO development kit will interface with the Arduino microprocessor through a breakout board purchased through a company called SparkFun.com. The breakout shield is pictured below in Figure 33.

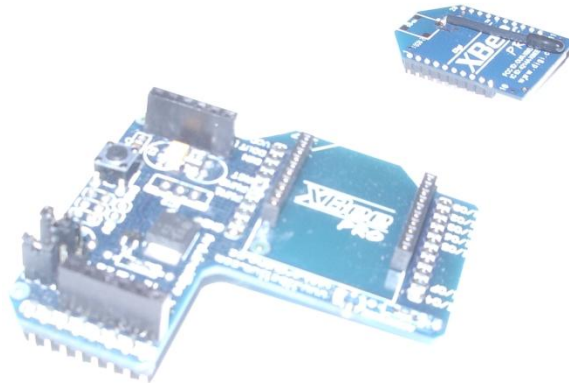

Figure 33 - XBee Shield

Since there are three protocols which need to be supported when dealing with OBD-II, the Mobile Wireless Unit must be able to understand and transmit information between the OBD-II connector and the XBee wireless component. This can become increasingly difficult due to the addition of interfaces throughout the system. Left unchanged, signals between a scan tool and the OBD-II port transmit over a wire. This project introduces a replacement for the wire by using wireless ZigBee protocol, thus introducing an interface that must transmit the data in a medium that it can translate back into OBD-II signals later.

4.1.2.2 Base Station Unit Interfaces

The Base Station Unit is a bit more complicated than the Mobile Wireless Unit. There are three interfaces identified. The first interface, the ZigBee-PRO with the Arduino Microprocessor, is similar and will work the exact same way that the Mobile Wireless Unit's interface works. One may reference Figure 15 for more information on the Mobile Wireless Unit's interface.

The second interface in the BSU involves the connection between the BSU and an existing OBD-II scanner. The existing scanner is able to connect to the BSU as if the BSU was the automobile being scanned.

4 Signal Representations

For the convenience of the reader, this project team has put together some examples of theory signal generation and its real-world representation.

4.1 0xBB

The first signal which is represented is the bit stream 1-0-1-0-1-0-1-0. This bit stream represents the hexadecimal 0xBB. The theory signal is shown in Figure 34 below. This figure is a relatively good way of identifying longer pulses in sequence which generates this bit stream.

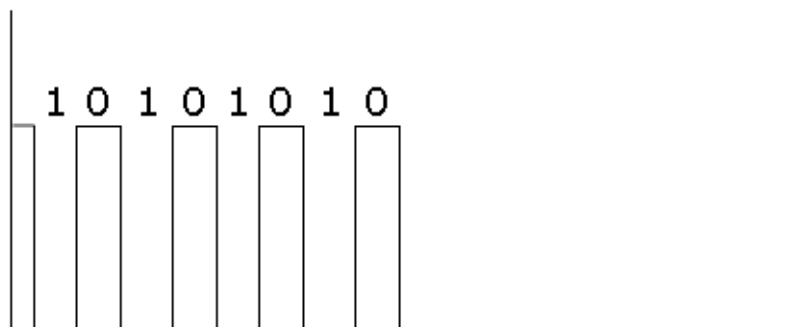

Figure 34 - 0xBB Signal (Theory)

As one can see, it is a string of longer pulses at both high and low. Referencing Figure 9, the reader can decipher this string to read 1-0-1-0-1-0-1-0. Now that the reader knows what the signal looks like in theory, the hardware created and used in this project can be used to generate the signal.

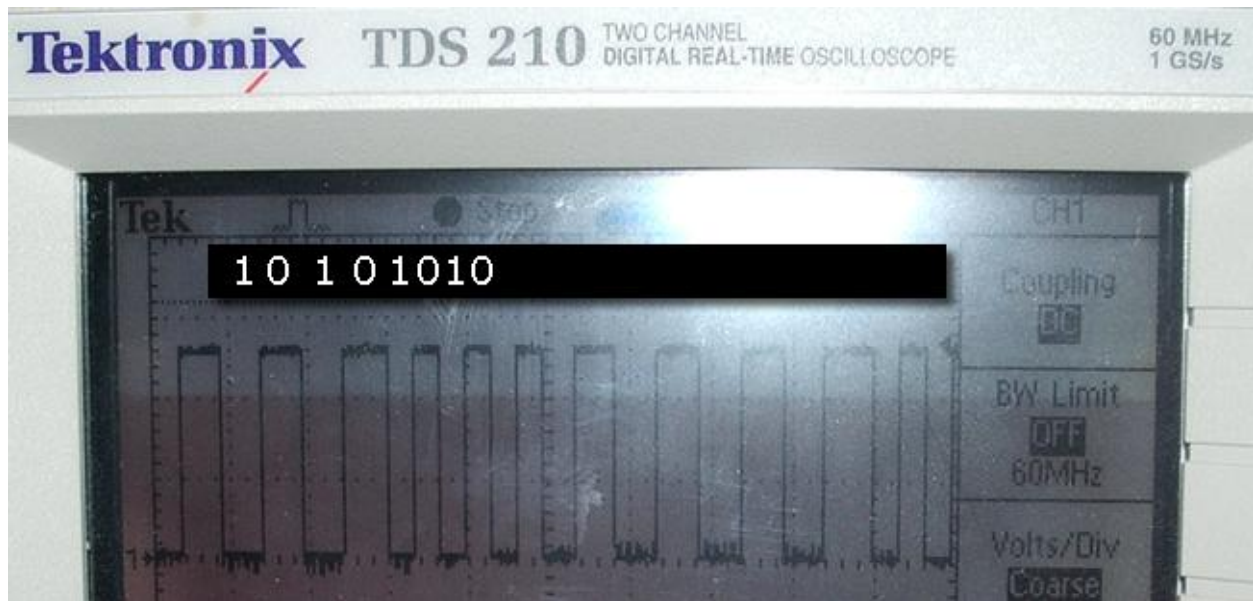

Figure 35 - 0xBB Signal (Practice)

0xBB has been created using the hardware in this project. A Two channel digital real time oscilloscope has been used to show the signal in its truest form. For convenience, the black box above the signal in Figure 35 helps the reader decipher where the bits are 0, and where they are 1.

4.2 0x55

The second example theory vs. practice signals generated using J1850 VPW is 0x55, which has the bit stream 0-1-0-1-0-1-0-1. One may assume that this bit stream is the same over time as 1-0-1-0-1-0-1-0, but that is not the case. Since there is an additional consideration of the Bus' last

state, the active signals versus the passive signals change their dynamic and the reader will see that there is now a different signal. Figure 36 shows a representation for this signal in theory.

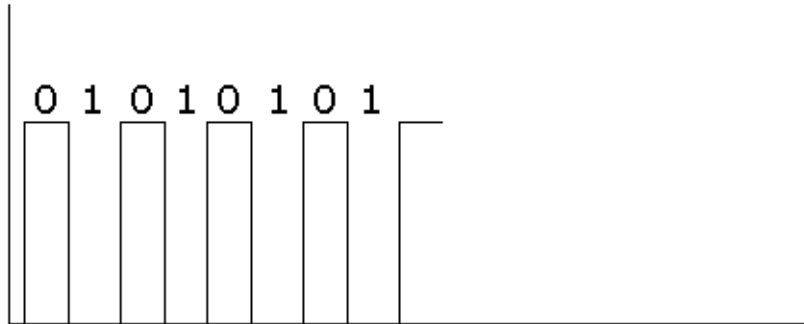

Figure 36 - 0x55 Signal (Theory)

The signal differs from 0xBB such that the active and passive bits are flipped. What was once active is now passive, and the timing for each bit changes. Figure 37 shows the signal on the oscilloscope.



Figure 37 - 0x55 Signal (Practice)

Viewing this new signal in the oscilloscope shows the timing to be different. This project was successful in that we were able to generate VPW bits to interface with a scan tool.

5 Communication

The first stage for communication was between a laboratory DC power supply and a desktop computer via RS232 over a standard DE9 serial port. Using the desktop computer standard HyperTerminal, the user prompted to name the file, select which COM port to use, set the bits per second, data bits, parity, stop bits as well as flow control. As shown in the figures below, COM port 1 is selected, the bits per second is set to 9600, 8 data bits, no parity, 1 stop bit, and flow control is by the hardware. The power supply's negative probe was connected the ground rail of the board and the power supply's positive probe was connected to the 12V power rail. After setting the voltage of the power supply to 12 volts with a minimal current of a half amp, the output button was pressed. The LED sequence including the additional blink from the Tx LED was successful and the computer's HyperTerminal correctly displayed the message "ELM327 v1.2a." At this point no other communication could be made without vehicle connectivity.

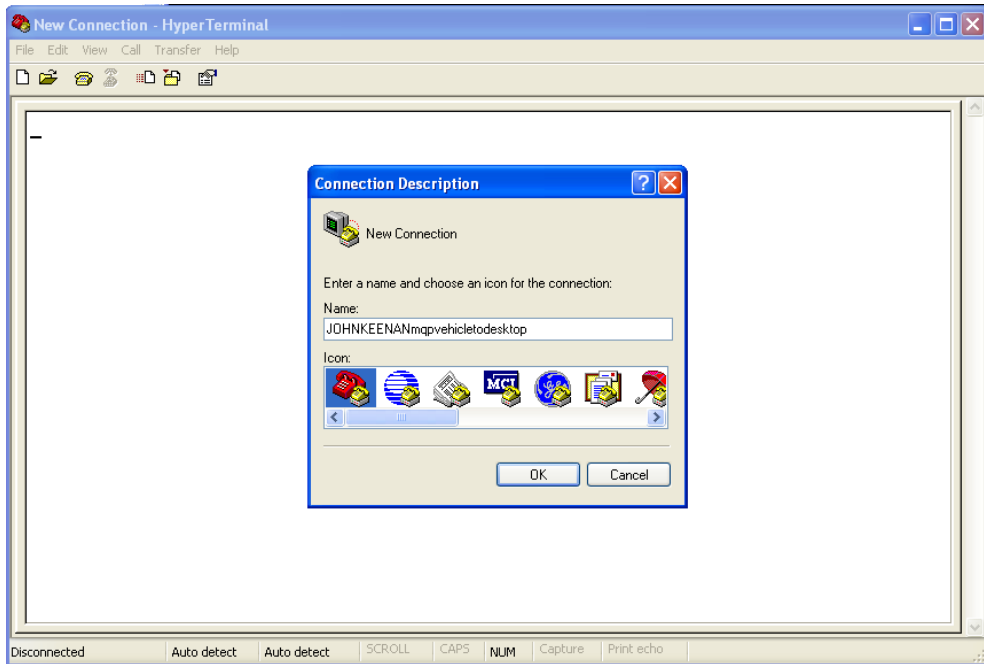

Figure 38 - HyperTerminal File Name

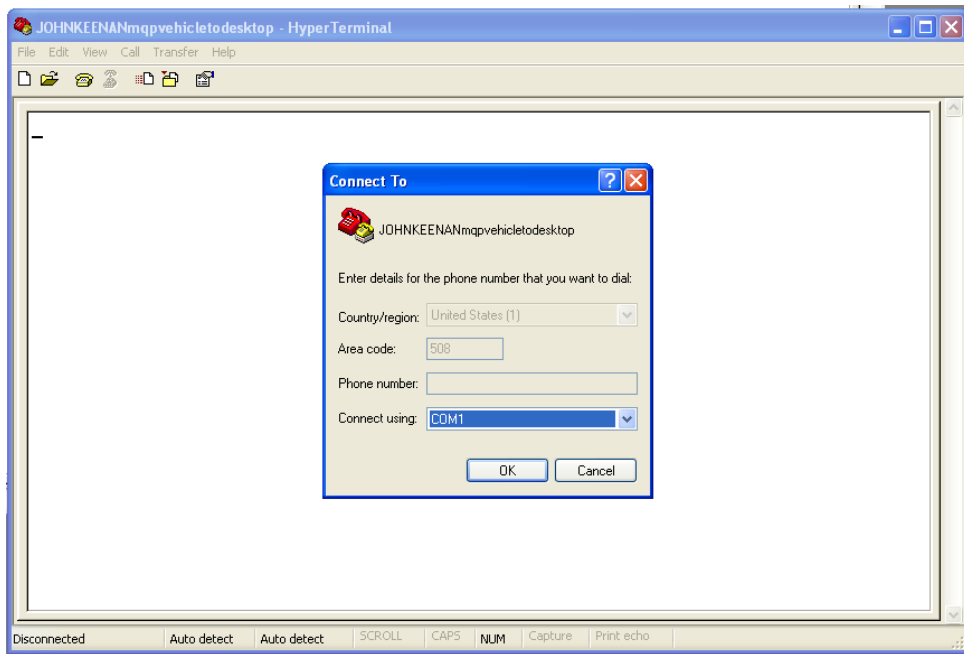

Figure 39 – HyperTerminal COM Selection

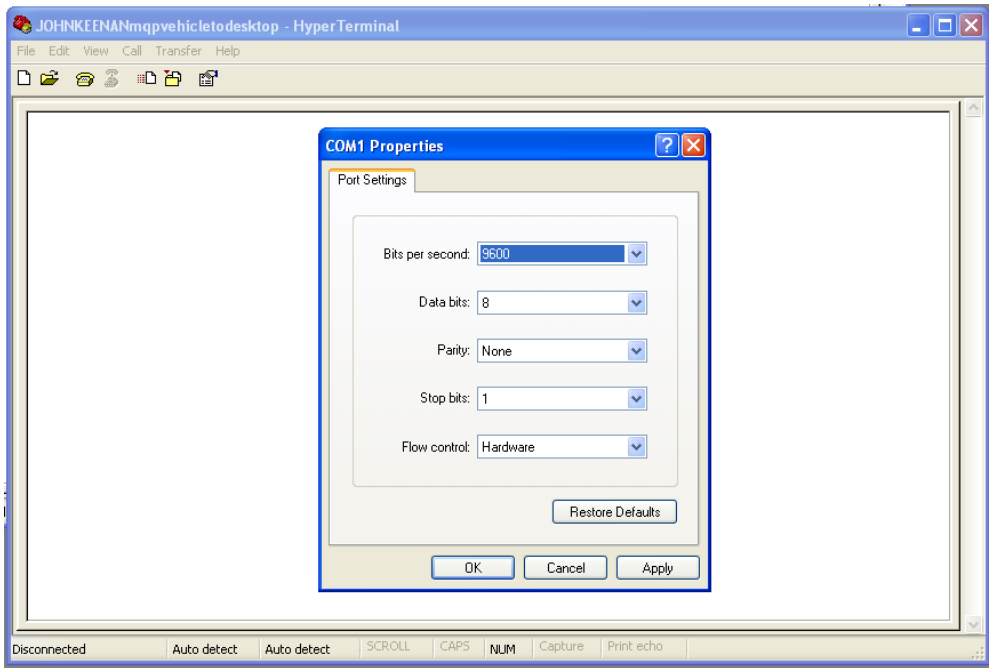

Figure 40 - HyperTerminal Port Settings

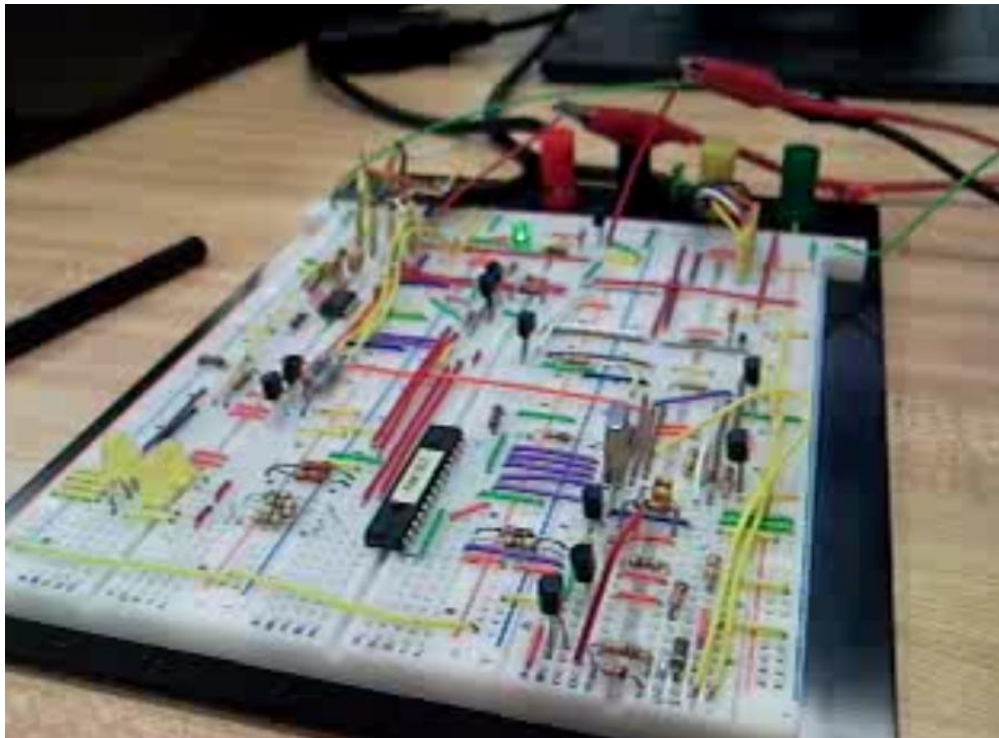

Figure 41 - Board Connected to Power Supply and Computer

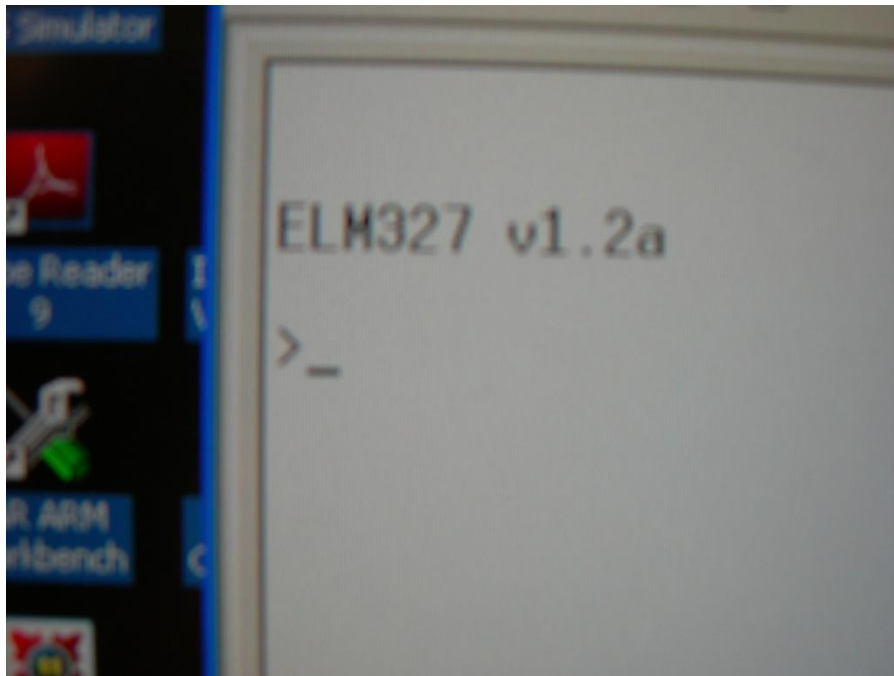

Figure 42 - HyperTerminal Message Display

Stage two for communication is between a vehicle and a desktop computer using hardwired DB9 serial cables. Due to the removal of DB9 serial ports from laptops, the use of a desktop computer was necessary to test the communication between the vehicle and a computer. The HyperTerminal is opened and the process of naming the file, selecting the COM port, as well as selecting the port settings is completed the as before for the laboratory testing. With the desktop positioned in the passenger seat leg area of the vehicle and the HyperTerminal ready for communication, the male J1962 connector was plugged into the vehicles port. The correct LED sequence performed and the first message was sent to the HyperTerminal; “ELM327 v1.3a.”



Figure 43 - Desktop in Vehicle



Figure 44 - Male J1962 Connector ready to plug-in



Figure 45 - Wires all connected

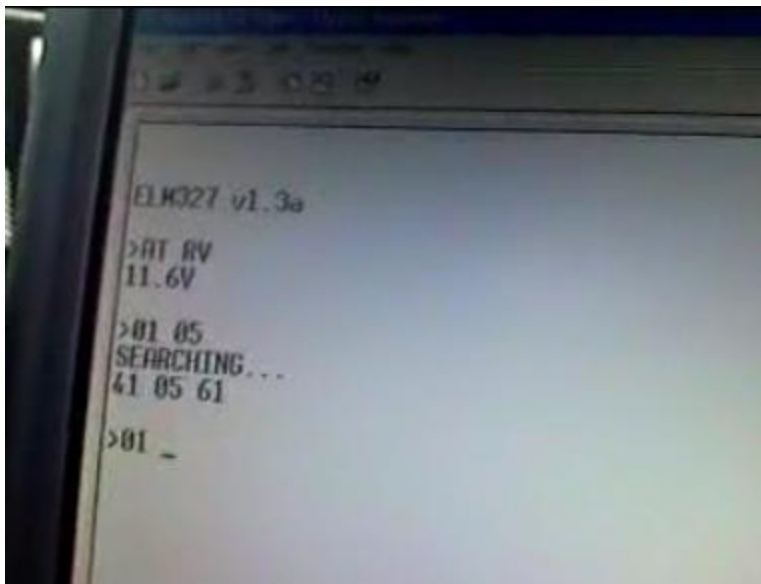

Figure 46 - Successful Communication

Communication between the Vehicle and the computer were now successful! To show a few of the capabilities of communication, commands were sent to the vehicle and the corresponding data was returned. Command “AT RV” is a request for the vehicle’s battery voltage which was 11.6 volts.

The third stage of communication included the second stage, communication between a vehicle and a computer, as well as implanting the use of a GUI, graphical user interface. For this, the decision was made to use EASYOBDII's software "EasyOBDII version 2.2.0." This GUI allows for Live Dashboard Feeds, Vehicle Scans, Data logging, Showing Faults and more, ideal for the use with our system.

Using serial cables to connect the board to the desktop computer and with the J1962 connector plugged into the vehicle, the "System Reset" button in EasyOBDII GUI is pressed and the interface shows successful connection as seen in the figure below.

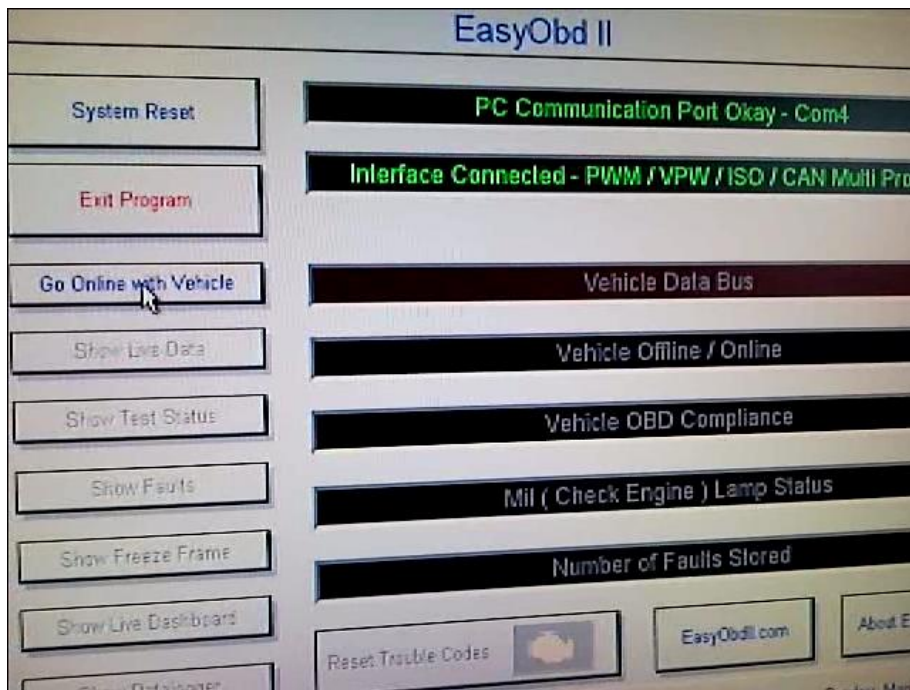

Figure 47 - EasyOBD II GUI

Next, the GUI checks the Vehicle Bus and Data, and also checks the vehicle response. The vehicle is verified to be OBD compliant and a scan for MIL, malfunction indicator lamp (known more commonly as the check engine light), begins. Seen in the figure below, the vehicle's MIL

lamp status is on due to three faults. By clicking the “Show Faults” button the faults are listed; the first is a cylinder misfire, the second identifies that it is the fourth cylinder that is misfiring and the third is for the oxygen sensor reporting that the vehicle is running too rich. After finding out what the faults were exactly, I cleared the codes using the “Clear Faults” button.



Figure 48 - EasyOBDII Operating

Taking the GUI to the next level a live data feed of the vehicles RPM, speed, temperature, throttle position and other data is available to the user. Another feature of EasyOBDII is the “Live Dashboard Feed.” Here, the GUI represents the vehicles dashboard live on the computer including the RPM, Speed, Temperature, Battery Voltage, MILs, and Throttle Position.

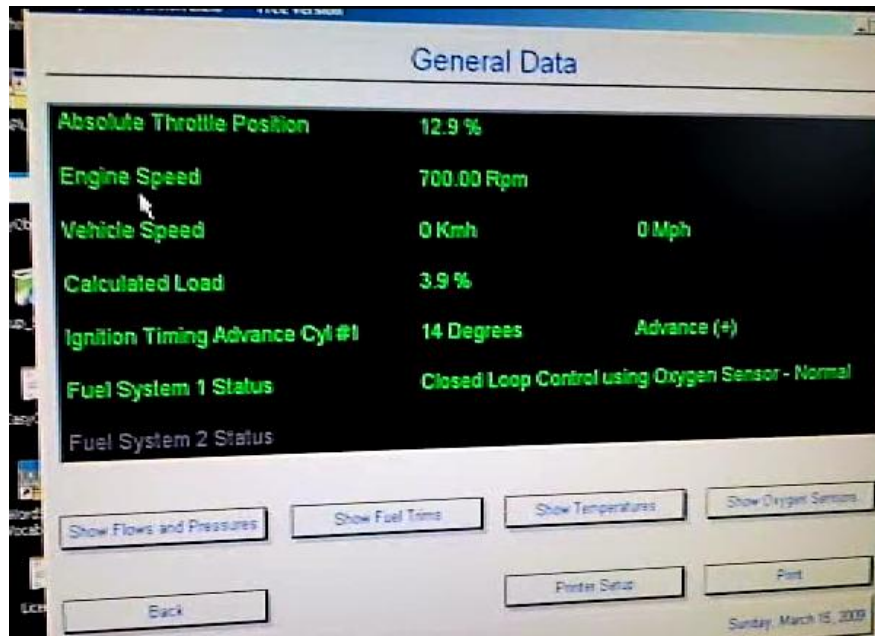

Figure 49 - EasyOBDII Live Feed

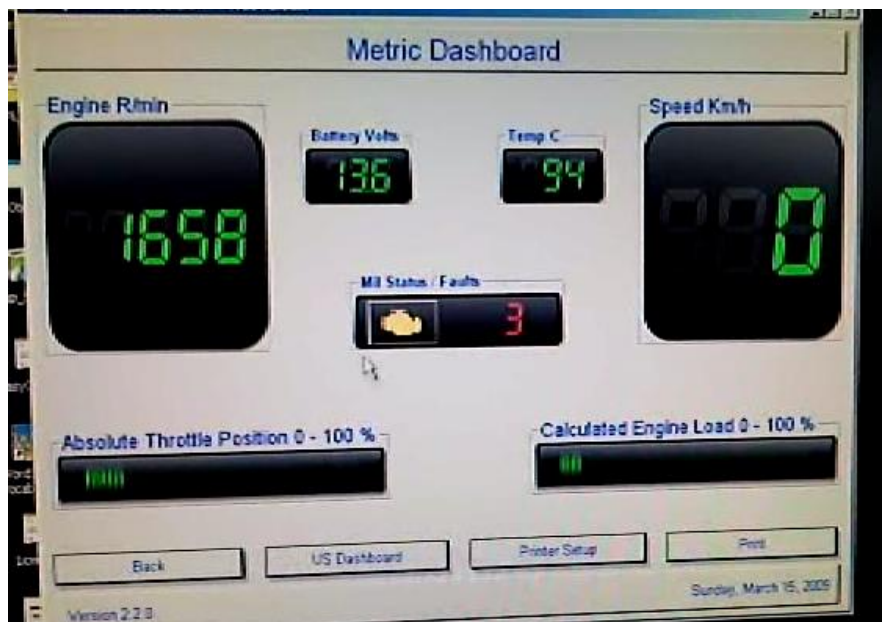

Figure 50 - EasyOBDII Live Dashboard Feed

Unfortunately, at the time that this paper was completed, there has not been a wireless transmission from a vehicle to a computer. When broken down into the components, there has been proven data communication between two XBee-PRO nodes, and there has also been proven

data communication between the computer and the XBee-PRO. Using a virtual USB to Serial converter supplied by DIGIKEY, communication and data transmission has also been successful between two computers and the two XBee-PROs. With all of these proven communications in place, data should seamlessly transmit through the different interfaces, although it has not been done thus far. The Arduino is programmed to read signals sent from the ELM327, and one can send signals back from the Arduino to the MWU.

6 Recommendations

Two of the biggest challenges faced by this group included a miss wired serial patch cable which led to a long duration of unsuccessful communication as well as ordering and waiting for parts to arrive. Four of the six goals set forth throughout the duration of the project have been accomplished; three types of communication, as well as the design and manufacturing of the printed circuit board. Goal five, wireless communication between the vehicle and computer, is still being debugged and until its completion, it keeps the sixth goal from being completed. The sixth goal of connecting the Arduino to the Mobile Wireless Unit in theory will work, and conquered immediately upon the success of goal five.

6.1 Multiple Mobile Wireless Units

With the customer in mind from the beginning of this project, work was done to allow a future expansion of the system to allow multiple Mobile Wireless Units to communicate with a singular Base Station Unit. If another team takes this continues this project, they should carefully study the ZigBee Mesh protocol to find out addressing techniques and further understand how protocol addressing is handled.

6.2 Scan Tool Implementation

One recommendation that this project would like to make to all future projects is that hardware truly is the best way to solve repeated, time-critical solutions. Implementing the signal generation for VPW in software was somewhat of a waste of time, it was inaccurate, was subject to hardware interrupts, and caused a lot of valuable time resources to be used. The knowledge of what the signal was supposed to look like was available, and it may have been helpful to have proof of concept, but it truly ended up wasting time, and the implementation for both VPW and PWM should have happened on the hardware from the beginning.

Implementing signal generation utilizing hardware interrupts is truly the way to implement communications protocols. The hardware understands when an interrupt is to occur, and it allows implemented software to perform functions when the signal on a line is at its correct state.

While the hardware was waiting for another interrupt, the next bit value could be loaded into a temporary placeholder for the interrupt routine to read. Since this move takes a very little amount of clock cycles, it can be assured that this execution will not be missed through hardware interrupts.

7 Conclusions

Due to the intense work done to interface with a vehicle's diagnostic's port, this team was able to achieve multiple goals set forth throughout the duration of this project. The team was able to successfully interface with a vehicle's OBD-II port, and communicate with the vehicle using and

HyperTerminal as well as a graphical user interface. The team was also able to receive live codes from the vehicle as those codes change and update as the vehicle is being driven.

Successful wireless communication was also made between two computers using HyperTerminals.

The main connector involved in the project, the J1962 female connector, is the vehicle's OBD-II port. The OBD-II port is based on standards that are proprietary and standard across the world. This project has the ability to interface with a vehicle through J1850 VPW, J1850 PWM, CAN, ISO 9141, KWM, and variations of these protocols, as well. The ability to do this was paramount in the creation of this project, and identified the first major milestone in the project.

This team further proved that RS232 signals could wirelessly be transmitted in a way that could be predicted to a Base Station Unit, utilizing the ZigBee protocol for a point-to-point network (rather than its initial use, a mesh-network).

Another accomplishment of this project was the start to finish design of a printed circuit board using National Instrument's MultiSim and UltiBoard software. With no prior experience in this field, this may have been the most beneficial part of the MQP for our future as Electrical and Computer Engineers.

The final fundamental accomplishment involves the emulation of bits utilizing the VPW, PWM J1850 protocols. This was a major milestone in the project because it concretely showed proof of concept for generation of these protocols' signals. With this knowledge, we were able to

create an interface that not only communicates with scan tool, but it also essentially reacts the same way the vehicle's OBD-II port does to requests from a scan tool.

While there was a bit of adversity faced between the team members of this project, the end result required much work and a strong commitment from the two partners. However we believe that we learned a great deal not only about automotive standard protocols, designing printed circuit boards as well as interfaces in general. Future projects involving the ground-up creation of electronics will run more smoothly due to the guidance provided by Professor Bitar. We would like to officially thank him for all of his help and guidance throughout the project.

Bibliography

- Powers, Chuck. 1992.** AN1212. [Online] 1992. [Cited: June 23, 2008.] http://www.diy-efi.org/gmecm/ecm_info/obd2/AN1212.REV0.PDF.
- Valentine, Richard. 1998.** Motor Control Electronic Handbook. *Motor Control Electronic Handbook*. s.l. : McGraw Hill, 1998.
- Perquin. 2001.** *OBD-II* [Online] 2001. [Cited: July 25, 2008.] <http://prj.perquin.com/obdii/>
- Beyer, Ronald. 2005.** *OBD-II Specifications* [Cited: April 19, 2008.] <http://obdproject.com/OBD2Info/Specs/>
- Micronics Forum. 2005.** *AVR J1850 VPW Interface* [Online.] <http://www.micronics.de/smf/index.php?topic=155.15>
- Stern, Trampas. 2005** *AVR J1850 Interface Code* [Online] <http://avrobdii.googlecode.com/svn/trunk/code/J1850.c>
- California, University of. 2006.** *Serial Communications* [Online] <http://esd.cs.ucr.edu/labs/serial/serial.html>
- Diagnostics, OBD. 2005.** *OBDII Message Structure* [Online] http://www.obddiagnostics.com/obdinfo/msg_struct.html
- Technologies, Werner. 2002.** *OBD2 Standards/Terms*. [Online.] <http://www.obd2crazy.com/techstd.html>
- Davis, Leroy. 1998.** *Glossary of Electronics and Engineering OBD Terms*. [Online] http://www.interfacebus.com/Glossary-of-Terms_OBD-interface.html
- Davis, Leroy. 1998.** *SAE J1850 Description, Electrical Interface Bus* [Online.] http://www.interfacebus.com/Automotive_SAE_J1850_Bus.html

Davis, Leroy. 1998. *CAN Bus Interface Description, CAN Bus Pinout, and Signal Names, Controller Area Network* [Online.]

http://www.interfacebus.com/Design_Connector_CAN.html

Oliver, D John. *Implementing the J1850 VPW protocol.* [Online.]

http://developer.intel.com/design/intarch/papers/j1850_wp.pdf

Breband. *CAN Information, Baudrate Equation.* <http://breband.net>

DGTech. *A Vehicle Network and its Components, Controller Area Network.* <http://DGTech.com>

ELM327 OBD to RS232 Interpreter, 2008.

Etschberger, Konrad. *Controller Area Network.* 2001

Intel. *Introduction to the Controller Area Network (CAN) Protocol.* 1995

Kvaser Advanced CAN Solutions. *The CAN Protocol Tour.* <http://kvaser.com/can/protocol>

Lawrenz, Wolfhard. *From Theory to Practical Applications: CAN.* 1997.

National Instruments. *Controller Area Network (CAN).* <http://ni.com/can/>

Robert Bosch GmbH, *CAN Specifications.* 1991

Texas Instruments, *Introduction to CAN.* 1997.

Appendixes

ELM327 OBD to RS232 Interpreter, 2008.



ELM327

OBD to RS232 Interpreter

Description

Almost all new automobiles produced today are required, by law, to provide an interface from which test equipment can obtain diagnostic information. The data transfer on these interfaces follow several standards, none of which are directly compatible with PCs or PDAs. The ELM327 is designed to act as a bridge between these On-Board Diagnostics (OBD) ports and a standard RS232 interface.

The ELM327 builds on improved versions of our proven ELM320, ELM322, and ELM323 interfaces by adding seven CAN protocols to them. The result is an IC that can automatically sense and convert the most common protocols in use today. There are a number of other improvements as well – a high speed RS232 option, battery voltage monitoring, and customizable features through programmable parameters, to name only a few.

The ELM327 requires few external components to make a fully functioning circuit. The following pages discuss the interface details, and show how to use the IC to 'talk' to your vehicle, then concludes with two schematics to get you started.

Features

- Supports 12 protocols
- RS232 baud rates to 500Kbps
- Automatically searches for protocols
- Fully configurable with AT commands
- Voltage input for battery monitoring
- Low power CMOS design

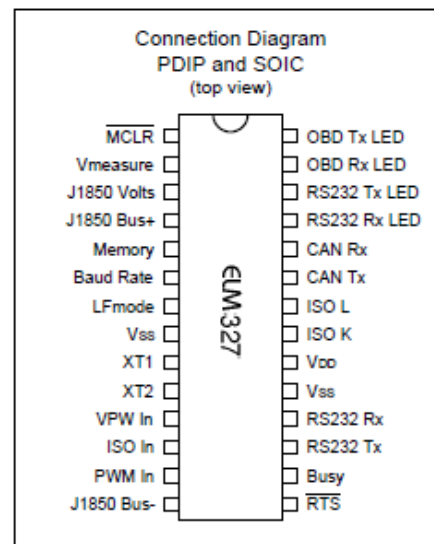

Applications

- Diagnostic trouble code readers
- Automotive scan tools
- Teaching aids

Block Diagram

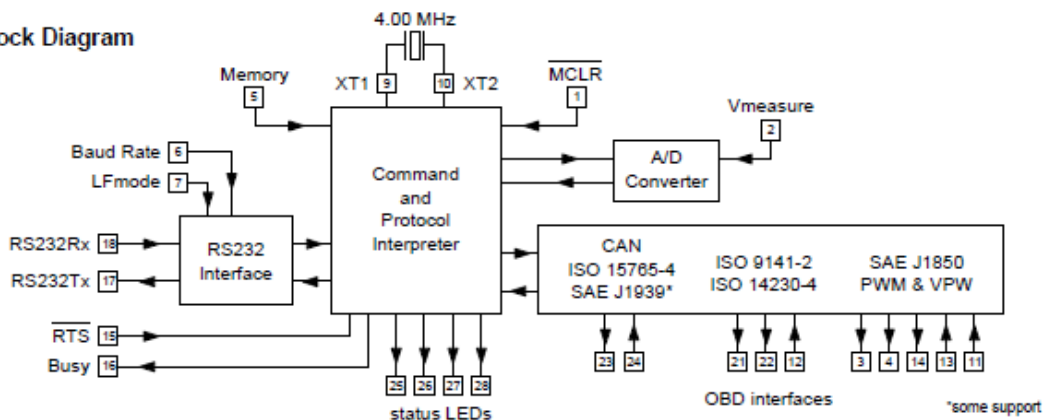



Pin Descriptions

MCLR (pin 1)

A momentary (>2 μ sec) logic low applied to this input will reset the ELM327. If unused, this pin should be connected to a logic high (V_{DD}) level.

Vmeasure (pin 2)

This analog input is used to measure a 0 to 5V signal that is applied to it. Care must be taken to prevent the voltage from going outside of the supply levels of the ELM327, or damage may occur. If it is not used, this pin should be tied to either V_{DD} or V_{SS} .

J1850 Volts (pin 3)

This output can be used to control a voltage supply for the J1850 Bus+ output. The pin will output a logic high level when a nominal 8V is required (for J1850 VPW), and will output a low level when 5V is needed (as for J1850 PWM applications). If this switching capability is not required for your application, this output can be left open-circuited.

J1850 Bus+ (pin 4)

This active high output is used to drive the J1850 Bus+ Line to an active level. Note that this signal does not have to be used for the Bus- Line (as was the case for the ELM320), since a separate J1850 Bus- drive output is provided on pin 14.

Memory (pin 5)

This input controls the default state of the memory option. If this pin is at a high level during power-up or reset, the memory function will be enabled by default. If it is at a low level, then the default will be to have it disabled. Memory can always be enabled or disabled with the AT M1 and AT M0 commands.

Baud Rate (pin 6)

This input controls the baud rate of the RS232 interface. If it is at a high level during power-up or

reset, the baud rate will be set to 38400 (or the rate that has been set by PP 0C). If at a low level, the baud rate will always be 9600.

LFmode (pin 7)

This input is used to select the default linefeed mode to be used after a power-up or system reset. If it is at a high level, then by default messages sent by the ELM327 will be terminated with both a carriage return and a linefeed character. If it is at a low level, lines will be terminated by a carriage return only. This behaviour can always be modified by issuing an AT L1 or AT L0 command.

Vss (pins 8 and 19)

Circuit common must be connected to these pins.

XT1 (pin 9) and XT2 (pin 10)

A 4.000 MHz oscillator crystal is connected between these two pins. Loading capacitors as required by the crystal (typically 27pF each) will also need to be connected between each of these pins and circuit common (V_{SS}).

Note that this device has not been configured for operation with an external oscillator – it expects a crystal to be connected to these pins. Use of an external clock source is not recommended.

VPW In (pin 11)

This is the active high input for the J1850 VPW data signal. When at rest (bus recessive) this pin should be at a low logic level. This input has Schmitt trigger waveshaping, so no special amplification is required.

ISO In (pin 12)

This is the active low input for the ISO 9141 and ISO 14230 data signal. It is derived from the K Line, and should be at a high logic level when at

All rights reserved. Copyright 2005, 2006, 2007, and 2008 by Elm Electronics Inc.
Every effort is made to verify the accuracy of information provided in this document, but no representation or warranty can be given and no liability assumed by Elm Electronics with respect to the accuracy and/or use of any products or information described in this document. Elm Electronics will not be responsible for any patent infringements arising from the use of these products or information, and does not authorize or warrant the use of any Elm Electronics product in life support devices and/or systems. Elm Electronics reserves the right to make changes to the device(s) described in this document in order to improve reliability, function, or design.



Pin Descriptions (continued)

rest (bus recessive). No special amplification is required, as this input has Schmitt trigger waveshaping.

PWM In (pin 13)

This is the active low input for the J1850 PWM data signal. It should normally be at a high level when at rest (ie. bus recessive). This input has Schmitt trigger waveshaping, so no special amplification is required.

J1850 Bus- (pin 14)

This active high output is used to drive the J1850 Bus- Line to an active (dominant) level for J1850 PWM applications. If unused, this output can be left open-circuited.

$\overline{\text{RTS}}$ (pin 15)

This active low "Request To Send" input can be used to interrupt the OBD processing in order to send a new command. Normally high, the line is brought low for attention, and should remain so until the Busy line (pin 16) indicates that the ELM327 is no longer busy. This input has Schmitt trigger waveshaping.

Busy (pin 16)

This active high output shows the current state of the ELM327. If it is at a low level, the processor is ready to receive ASCII commands and characters, but if it is at a high level, commands are being processed.

RS232Tx (pin 17)

This is the RS232 data transmit output. The signal level is compatible with most interface ICs (output is normally high), and there is sufficient current drive to allow interfacing using only a PNP transistor, if desired.

RS232Rx (pin 18)

This is the RS232 receive data input. The signal level is compatible with most interface ICs (when at idle, the level is normally high), but can be used with other interfaces as well, since the input has Schmitt trigger waveshaping.

V_{DD} (pin 20)

This pin is the positive supply pin, and should always be the most positive point in the circuit. Internal circuitry connected to this pin is used to provide power on reset of the microprocessor, so an external reset signal is not required. Refer to the Electrical Characteristics section for further information.

ISO K (pin 21) and ISO L (pin 22)

These are the active high output signals which are used to drive the ISO 9141 and ISO 14230 buses to an active (dominant) level. Many new vehicles do not require the L Line – if yours does not, you can simply leave pin 22 open-circuited.

CAN Tx (pin 23) and CAN Rx (pin 24)

These are the two CAN interface signals that must be connected to a CAN transceiver IC (see the Example Applications section for more information). If unused, pin 24 should be connected to a logic high (V_{DD}) level.

RS232 Rx LED (pin 25), RS232 Tx LED (pin 26), OBD Rx LED (pin 27) and OBD Tx LED (pin 28)

These four output pins are normally high, and are driven to low levels when the ELM327 is transmitting or receiving data. These outputs are suitable for directly driving most LEDs through current limiting resistors, or interfacing to other logic circuits. If unused, these pins may be left open-circuited.

Note that pin 28 can also be used to turn off all of the Programmable Parameters - see page 45 for details.

Ordering Information

These integrated circuits are 28 pin devices, available in either a 300 mil wide plastic ('skinny') DIP format or in a 300 mil SOIC surface mount type of package. To order, add the appropriate suffix to the part number:

300 mil 28 pin Plastic DIP.....ELM327P 300 mil 28 pin SOIC.....ELM327SM