



Construction of a Wind Turbine Project in the Town of Florida, MA

A Major Qualifying Project
Submitted to the faculty of
Worcester Polytechnic Institute
in partial fulfillment of the requirements for the
Degree of Bachelor of Science

Submitted by:

Matthew Burger
Sean Colella
Sean Quinlivan
Joel Rousseau

Sponsoring Agency:

Worcester Polytechnic Institute

Submitted To:

Project Advisor:
Tahar El-Korchi

Date: March 1, 2007
windmqp@wpi.edu

Abstract

This Major Qualifying Project (MQP) presents recommendations for the design and construction of a feasible 7.5 mega Watt (1.5 mW/turbine) wind turbine power generation plant in the town of Florida, MA. This project addresses the following topics and issues: permitting, land acquisition, turbine foundation design and construction, access road design and construction, operations and maintenance building design, substation design, soil analysis and retaining wall design, power output to the national grid, a detailed cost estimate and environmental conservation issues.

Table of Contents

1	Introduction.....	12
1.1	History of Wind Power.....	16
1.2	Wind Turbine Technology.....	17
1.3	World Wide Wind Energy.....	19
1.4	Massachusetts Wind Power.....	23
1.5	Hoosac Wind Project.....	24
1.6	PPM Energy.....	25
2	Background.....	26
2.1	Site Location Assessment.....	26
2.1.1	Environmental Impacts.....	29
2.1.2	Visual Impacts.....	33
2.2	Construction of Proposed Wind Turbine Power Site.....	34
2.3	Local / Access Roads and Turbine Pads.....	34
2.4	Construction of the Wind Turbine Foundation.....	37
2.5	Wind Turbine Transportation to Florida, Massachusetts.....	39
2.6	Wind Turbine Components.....	41
2.6.1	Rotor.....	42
2.6.2	Yaw Drive.....	43
2.6.3	Transmission.....	43
2.6.4	Generator.....	44
2.6.5	Tower.....	45
2.7	Wind Power Plant Layout.....	46
2.7.1	Operation and Maintenance (O&M) Facility.....	47

2.7.2	Control and Communications System	47
2.7.3	Electrical Power Collection System.....	47
3	Methodology.....	54
3.1	Turbine Foundation Design & Structural Analysis	54
3.2	Access Roads	60
3.2.1	Design of Access Roads.....	60
3.2.2	Clearing and Grubbing.....	62
3.2.3	Excavation of Native Soils.....	62
3.2.4	Construction of Access Roads	63
3.3	Operation and Maintenance Building	63
3.4	Culverts.....	75
3.4.1	Inlet Design.....	75
3.4.2	Outlet Design	78
3.5	Soil Mechanics.....	79
3.5.1	Unit Shear and Stress	80
3.5.2	Simple Bearing Capacity	80
3.5.3	Terzaghi's Bearing Capacity.....	81
3.5.4	Factor of Safety.....	81
3.5.5	Compressibility.....	82
3.5.6	Settlement	82
3.5.7	Lateral Earth Pressure.....	83
3.5.8	Retaining Walls.....	84
3.6	Substation Design	90

3.7	Power Output of Project.....	92
4	Results & Cost Analysis	96
4.1	Turbine Foundation.....	96
4.1.1	Cost of Turbine Foundation.....	98
4.2	Gravel Roads.....	99
4.2.1	Costs for Gravel Road Construction.....	100
4.3	Operations and Maintenance Building.....	101
4.3.1	Cost of Operations Management Building	103
4.4	Culverts.....	104
4.4.1	Culvert Cost Analysis	104
4.5	Retaining Wall	105
4.5.1	Cost Estimate of Retaining Wall.....	106
4.6	Wind Turbine	110
4.6.1	Cost of Wind Turbines.....	110
4.7	Electrical System	110
4.7.1	The Electrical System Cost.....	110
4.8	Manitowac 2250 Crane.....	111
4.8.1	Cost of Manitowac 2250 Crane	111
4.9	Concrete Batch Plant.....	111
4.9.1	Concrete Batch Plant Cost	112
4.10	Total Projected Cost.....	112
5	Recommendations.....	113
6	References.....	117

7	Appendix.....	119
7.1	Foundation Design Calculations.....	119
7.1.1	Foundation Costs	128
7.1.2	Foundation Images.....	131
7.2	Gravel Road Design.....	132
7.2.1	Access Road Images	142
7.2.2	Base & Sub base Layers	147
7.2.3	Road Material.....	150
7.2.4	Truck Load Images	152
7.2.5	Access Road Cost	156
7.3	Operations and Maintenance Building Calculations.....	163
7.3.1	Operations and Maintenance Building Cost	212
7.4	Culvert Design Calculations	214
7.5	Retaining Wall Calculations	231
7.5.1	Retaining Wall Pictures	242
7.5.2	Soil Calculations	244
7.5.3	Wind Turbine Images	265
7.6	Electrical System Calculations	267

List of Figures

Figure 1: Global Annual Mean Temperatures 1880-2005	13
Figure 2: Carbon Dioxide Emissions	14
Figure 3: Annual Petroleum Imports in the US	15
Figure 4: Wind Turbine Components	17
Figure 5: Worldwide Wind Energy Capacity	20
Figure 6: Cost per Kilowatt Hour 1980-2020 (projected)	20
Figure 7: World Wind Electricity-Generating Capacity by Country 1980-2005	22
Figure 8: Hans Bakke.....	26
Figure 9: Town of Florida in Northwestern Massachusetts.....	27
Figure 10: Bakke Mountain Location	27
Figure 11: Annual Mean Wind Speeds in Northwestern Massachusetts.....	28
Figure 12: Bakke Mountain Terrain	28
Figure 13: The Golden Rod Plant.....	31
Figure 14: Visual Simulation of completed Hoosac Wind Turbine Project.....	33
Figure 15: Wind Turbine Components	42
Figure 16: Proposed Turbine Site Layout.....	46
Figure 17: Operation and Maintenance Building.....	64
Figure 18: Foundation Cross Section.....	65
Figure 19: Foundation Plan.....	66
Figure 20: Truss design #1.....	72
Figure 21: Truss design #2.....	72
Figure 22: Plywood orientation	73

Figure 23: Nailing schedule 73

List of Tables

Table 1: US Energy Consumption by Source Type in 2005.....	15
Table 2: Renewable Energy Increase.....	23
Table 3: Total Damage vs. Thickness for Serviceability and Rutting Criteria.....	61
Table 4: Load Types	68
Table 5: Load Combinations.....	69
Table 6: O&M Components.....	75
Table 7: Cost of Energy	93
Table 8: Funding Costs.....	94
Table 9: Cost for Access Road.....	101
Table 10: O&M Cost	103
Table 11: Retaining Wall Cost.....	107
Table 12: Total Cost.....	112

List of Equations

Equation 1: Kinetic Energy of Wind	18
Equation 2: Power Delivered	19
Equation 3: Power Loss	48
Equation 4: Current.....	48
Equation 5: Drag Force.....	55
Equation 6: Moment Equation.....	56
Equation 7: Shear Equation	56
Equation 8: Critical Shear Force.....	56
Equation 9: Cantilever Distance	57
Equation 10: Factored Bending Moment.....	57
Equation 11: Area of Steel.....	58
Equation 12: Legth.....	59
Equation 13: Interactive Stress Equation #1	70
Equation 14: Interactive Stress Equation #2.....	71
Equation 15: Flow Rate	75
Equation 16: Culvert Pipe Diameter.....	77
Equation 17: Inlet Elevation at Culvert Face.....	77
Equation 18: Inlet Elevation at Culvert Face (2)	77
Equation 19: Culvert Face Elevation	78
Equation 20: Tail Water Depth.....	78
Equation 21: Depth of Culvert Invert to HGL.....	78
Equation 22: Unit Shear.....	80

Equation 23: Bearing Capacity	80
Equation 24: Ultimate Bearing Capacity	81
Equation 25: Soil Compressibility	82
Equation 26: Ultimate Consolidation Settlement	83
Equation 27: Lateral Pressure	83
Equation 28: Lateral Pressure Factor K	83
Equation 29: Active Pressure Coefficient.....	85
Equation 30: Base Length.....	85
Equation 31: Horizontal Force.....	85
Equation 32: Effective Depth.....	86
Equation 33: Effective Depth.....	87
Equation 34: Soil Pressure	88
Equation 35: Area of Steel.....	89
Equation 36: Resisting Moment Force	89
Equation 37: Capacity Factor.....	92
Equation 38: Cost of Energy.....	94

1 Introduction

This portion of the report discusses issues and arguments behind the need for renewable energy and a short history of wind power.

Renewable energy is being highly sought now, more than ever, as fossil fuels are being depleted and the high costs are ever increasing to search deeper into the earth and reach out to more foreign areas for energy sources. This is especially true in The United States which houses 4.7% of the world's population, yet uses nearly 25% of the world's energy each year. Currently the U.S. imports one half of the fossil fuel energy it uses annually, costing nearly \$65 billion. Fossil fuel reserves in the U.S. are rapidly depleting, and it very costly if the nation had to rely solely on imported fossil fuels.¹

As current oil quantities run low in the United States, new exploration of oil has become common. Finding large quantities of oil is a difficult task, which often requires high tech equipment for oil extraction. In many cases it is necessary to probe four to six miles into the earth in search of rock and oil characteristics that could be extracted as profitable materials.² Petroleum is the country's main source of energy and more than one half of the United States national consumption is currently being imported annually. This fact has increased the need for alternate energy sources.

Many of these alternate energy sources are renewable types of energy. Renewable energy is currently available by means of solar energy, fuel cells, and wind energy. However, many types of renewable energy sources are still in the trial phase and

¹ <http://dieoff.org/page84.htm>

² Environmental Science Activities for the 21st Century

the long term results are uncertain. In most cases, states and towns are given tax breaks and incentives for constructing and implementing renewable energy sources, which has led to recent growth in the renewable energy field.

In addition to the fact that traditional energy sources are being used up, the burning of fossil fuels for energy release a tremendous amount of carbon dioxide into the atmosphere. Carbon Dioxide is known to deplete the protective outer layer of the atmosphere, which is more commonly known as the ozone layer. The result of ozone depletion is global warming, which is depicted in Figure 1. According to the graph it is evident that annual average temperatures are steadily increasing.

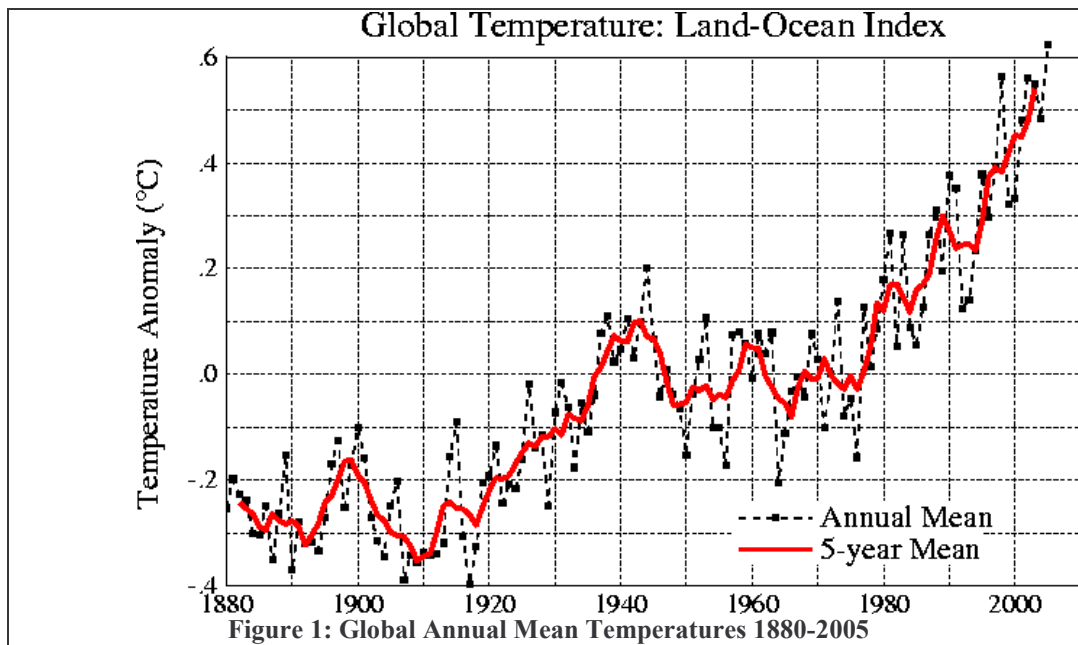
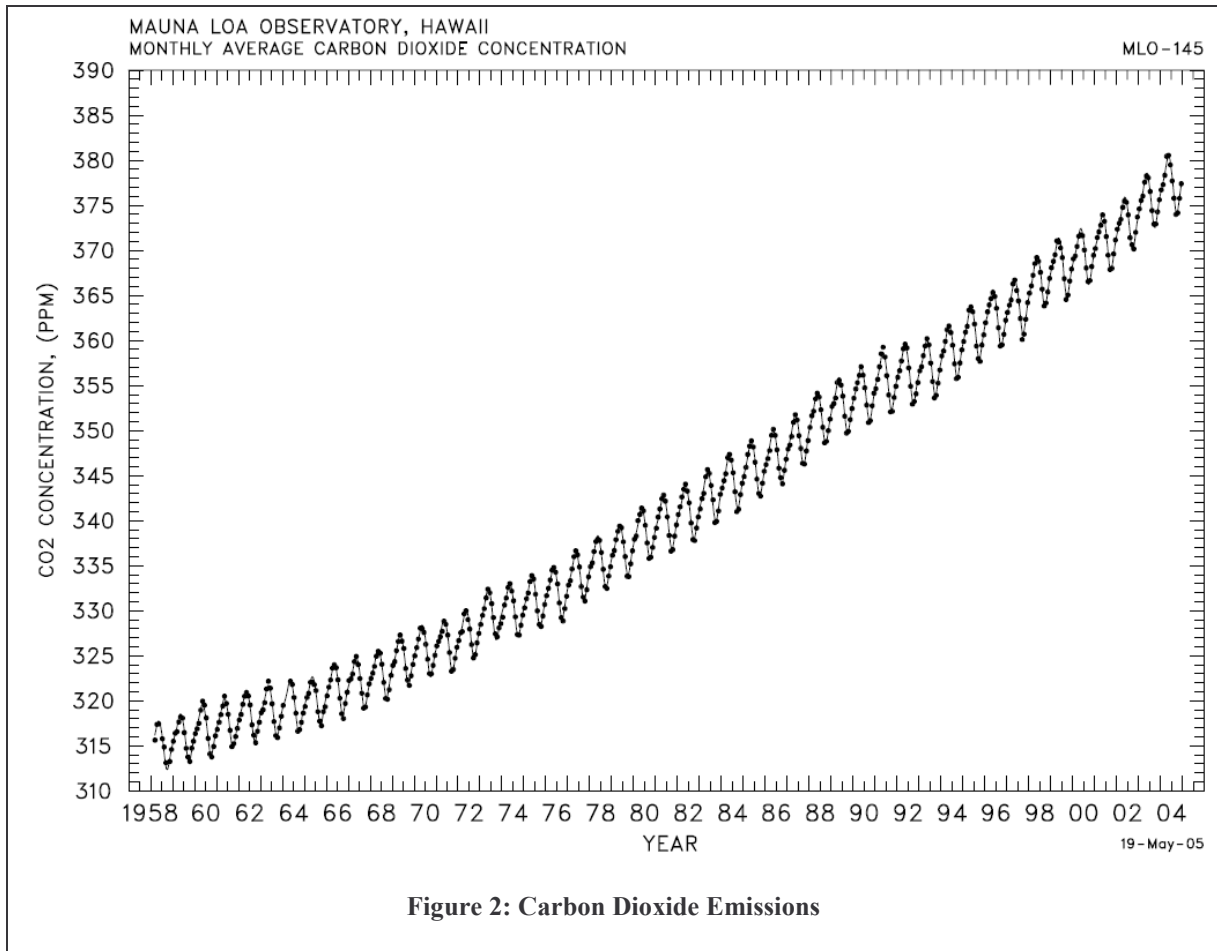

Figure 1: Global Annual Mean Temperatures 1880-2005

Some scientists argue that global warming is a natural geological process, that temperatures are cyclic and will go in reverse in the coming years. The fact is that carbon dioxide emissions and other “green house” gases trap more infrared energy than occur naturally in the atmosphere. This phenomenon results in a production of additional heat,

which increases the temperature of the atmosphere and earth surface. Figure 2, shows a steady increase in CO₂ levels from 1958-2004. This steady increase illustrates the ever increasing need to acquire a new environmentally friendly means of energy production based on the detrimental effects which are produced by “green house” gases and huge amounts of carbon dioxide emissions from fossil fuels.



Energy made from petroleum, coal, natural gas and nuclear power plants provides the majority of energy used in The United States. Fossil fuels currently support 85.7% of our nation’s energy usage. Figure 3, shows a breakdown of the major energy sources used in The United States in 2005.

Energy Consumption Type in U.S. in 2005	
<u>Energy Type</u>	<u>Percentage</u>
Petroleum	40.2
Natural Gas	22.6
Coal	22.9
Nuclear	8.1
Renewable	6.1

Table 1: US Energy Consumption by Source Type in 2005

Petroleum is the country's leading energy source, 65% of it is currently being imported yearly (shown in Figure 3).³ High costs for imported petroleum has played

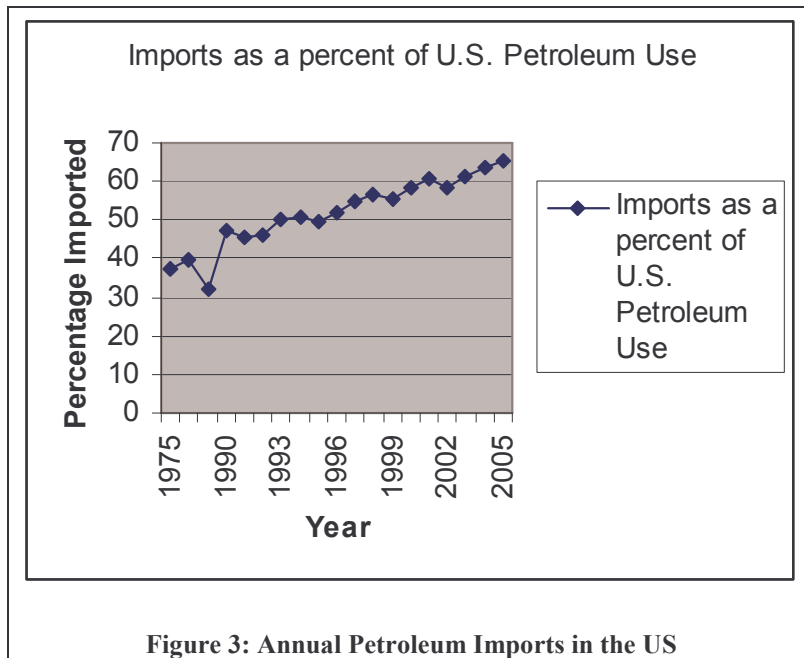

Figure 3: Annual Petroleum Imports in the US

³ http://www.crest.org/articles/static/1/Massachusetts_RPS.html

a large part in the increased desire for alternate energy sources. Many sources of renewable energy are currently available, but the long term results are uncertain. However, new tax credits and incentives for utilizing renewable energy sources have led to recent growth in the renewable energy field.

1.1 History of Wind Power

Wind Power has been utilized throughout history, dating back to 500 A.D. in Persia, when the first windmills were developed for grain-grinding and water-pumping.⁴ The wind power industry did not see any substantial growth however, until the 1970's when oil prices rose sharply and people began to question the world's reliance on non-renewable fossil fuels. It was not until then that the interest in wind power rose again. Following the 1970's, wind energy programs were established in most European nations and in the United States. Both private companies and the government began to conduct research on wind-generators. This new research sparked the creation of larger wind generators, some capable of producing megawatts of electric power, and they soon began to be installed in a number of countries worldwide. Presently, wind generated power is highly sought after and the installation and technology is on a rapid increase due to the high price and diminishing quantity of fossil fuel resources.

⁴ <http://www.telosnet.com/wind/early.html>

1.2 Wind Turbine Technology

The concept behind wind generated power is simple. Wind turbine blades are moved by the wind creating kinetic energy. Turbines use air foils or blades like the wing of an airplane to turn a central hub creating a rotational motion which captures the kinetic energy of the wind. This kinetic energy is then converted into electricity by rotating a series of gears and shafts, which transfer the energy to a generator. The generator technology is identical to that used by traditional fossil fuel generating plants. Wind turbines range from small residential systems to large utility systems. Wind power

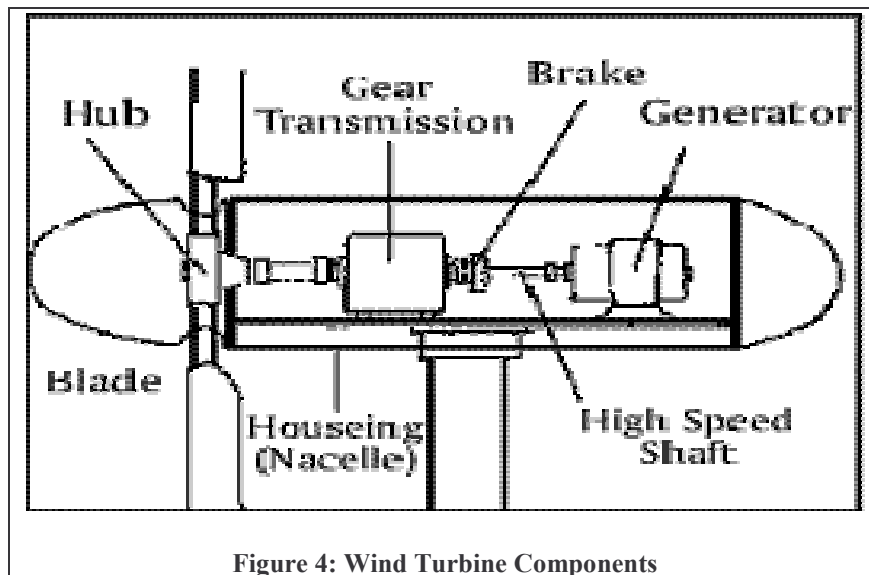

Figure 4: Wind Turbine Components

systems are modular and can be scaled easily to any application.

A basic schematic of the wind turbine components are shown in Figure 4, and are characteristic of all types of wind turbine systems.

$$KE = 0.5MV^2$$

Equation 1: Kinetic Energy of Wind

The available power in the wind is derived from the kinetic energy of air molecules and particles. The energy in wind is due to the kinetic energy of moving air. This is given where M is mass and V is velocity, or wind speed. The mass of the air can be found using the relative density of the air multiplied by the volume. This product yields the weight of the air, which can be inserted into Equation 1 along with the wind (air) velocity to calculate the kinetic energy.

It is also important to note that the power in the wind is proportional to the cube of the wind speed. This means that small increases in wind speed produce large increases in available wind power. A turbine works by slowing the wind down; the kinetic energy in the wind is transferred to kinetic energy of the wind turbine which in turn is converted into electrical power. However, not all the energy in the wind can be captured by the windmill. Scientists have found that the maximum percentage of the wind energy that can be extracted from blowing wind is 59.3 percent. This limit is known as the Betz limit. The Betz limit is an adjustment factor which “Says that you can only convert less than 16/27 or 59.3 percent of the kinetic energy in the wind.” [Betz' Law](#)⁵ This is the optimal ratio between stopping the air and forcing it to go around the machine. In the power

⁵ <http://www.windpower.org/en/core.htm>

equation for a wind turbine the Betz limit is referred to as C_p , and the power equation is shown below.

$$Power = C_p \times A \frac{1}{2} dV^3$$

**Equation 2: Power
Delivered**

Where:

C_p = the power efficiency of the rotor (Betz limit), explained above

A = swept area of the turbine blades = πr^2 ; ($\pi = 3.14$) r = radius of swept area, i.e.

blade length

d = density of air

V = wind speed

1.3 World Wide Wind Energy

There has been a staggering increase in the production and use of wind power over the last thirty years. Recently in 2004, the global wind power industry installed 7,976 megawatts (MW) of wind generated power, an increase in total installed generating capacity of twenty percent, according to figures recently released by the Global Wind Energy Council (GWEC). As of 2004, the total global wind power capacity had grown to roughly 47,500 MW of wind power. Since then, the Global wind electricity-generating capacity increased by 24 percent in 2005, to 59,100 megawatts, as shown in Figure 6. This represents a twelve fold increase from a decade ago, when world wind-generating capacity stood at less than 5,000 megawatts.

Wind is the world's fastest-growing energy source with an average annual growth

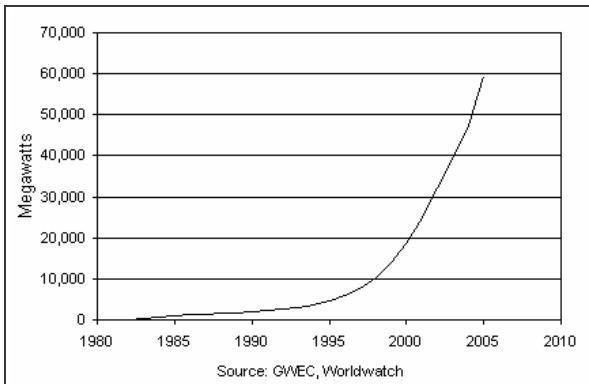

Figure 5: Worldwide Wind Energy Capacity

rate of 29 percent over the last ten years.

In contrast, over the same time period, coal use has grown by 2.5 percent per year, nuclear power by 1.8 percent, natural gas by 2.5 percent, and oil by 1.7 percent. This can be attributed to the dramatic decrease in the cost per kilowatt

hour throughout the history of wind power illustrated in Figure 7. Overall, the cost of wind power has decreased by nearly 90 percent since the 1980's to 4 cents or less per kilowatt-hour in prime wind sites.⁶

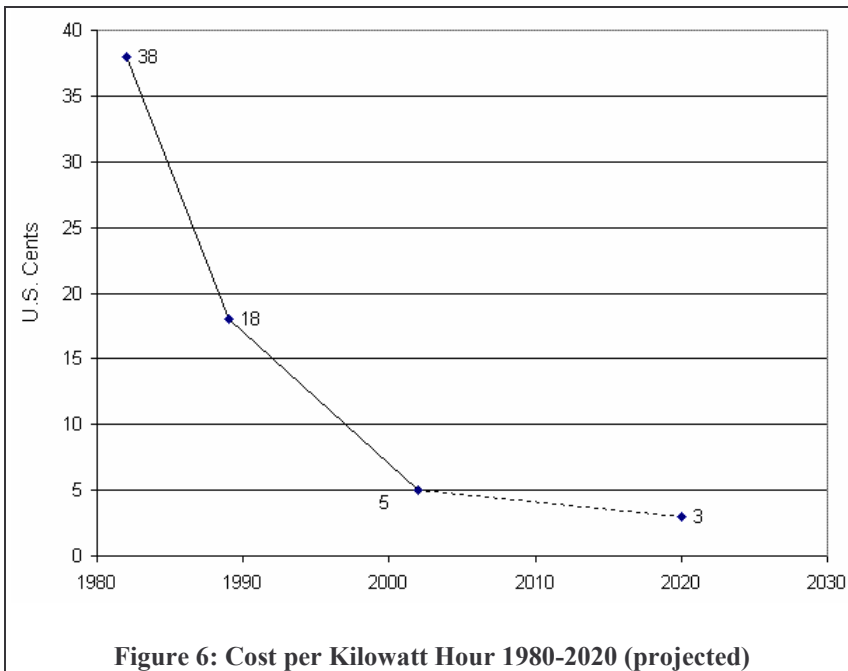

Figure 6: Cost per Kilowatt Hour 1980-2020 (projected)

The countries with the highest total installed wind power capacity are Germany (16,629 MW), Spain (10,000 MW), the United States (9,100 MW), Denmark (3,117 MW) and India (3,000

MW). These five countries account for roughly seventy five percent of the total wind energy installations worldwide. However, a number of countries, including Italy, the

⁶ EPI from NREL, EWEA

Netherlands, Japan, and the U.K., are near the 1,000-MW mark in national wind production.

Europe is the front runner in wind power production. Germany is the country with the most installed wind-generating capacity and currently receives six percent of its electricity from its 18,400 megawatts of wind power. Spain is next in line with over 10,000 megawatts of capacity and gets eight percent of its electricity from wind. Denmark's 3,100 megawatts of wind capacity can handle twenty percent of its electricity needs nationwide, the largest share in any country. This number ranks fifth worldwide in installed capacity. Denmark is also the global leader in offshore wind power installations, with 400 megawatts of existing capacity. Over 900 megawatts of offshore wind capacity will be installed by the end of 2006 in Europe.

The U.S. has installed 9,100 megawatts of wind power capacity. The U.S. wind industry installed a record-breaking 2,400 megawatts of wind power in 2005, a dramatic increase from installing just 370 megawatts in 2004 and 1,700 megawatts in 2003. This inconsistent growth is attributed to the intermittent availability of the federal wind production tax credit (PTC) that currently stands at 1.8¢ per kilowatt hour. In mid 2005, Congress extended the PTC by two years, marking the first time lawmakers extended the tax credit without first allowing it to lapse. With the PTC guaranteed for the year, the U.S. wind industry projects that it will install 25 percent more capacity in 2006 than it did in 2005.

Canada's installed wind capacity of 680 megawatts at the end of 2005 is expected to increase to 1,200 megawatts by the end of 2006. While Canada's federal government is striving toward the installation of 4,000 megawatts of wind energy by 2010, it has a

more drawn out governmental plan to install a total of 9,200 megawatts by 2015, which would be a substantial supplement to their current energy supply.

Asian countries have installed nearly 7,000 megawatts of wind-generated electricity capacity. India has 4,400 megawatts of capacity, ranking fourth after Germany, the United States, and Spain. Wind power in China, currently at 1,260 megawatts, is beginning to flourish due to the country’s new Renewable Energy Law. This law provides tax incentives and subsidies for wind power and targets the development of 30,000 megawatts of wind capacity by 2010. Ambitious as these goals are, experts within the Chinese wind industry report that China could produce 400,000 megawatts of wind capacity by 2050. For comparison, China’s total electric power generation capacity at the end of 2003 was 356,100 megawatts. Figure 8 shows a break down of the world wind electricity-generating capacity by country between 1980 and 2005.

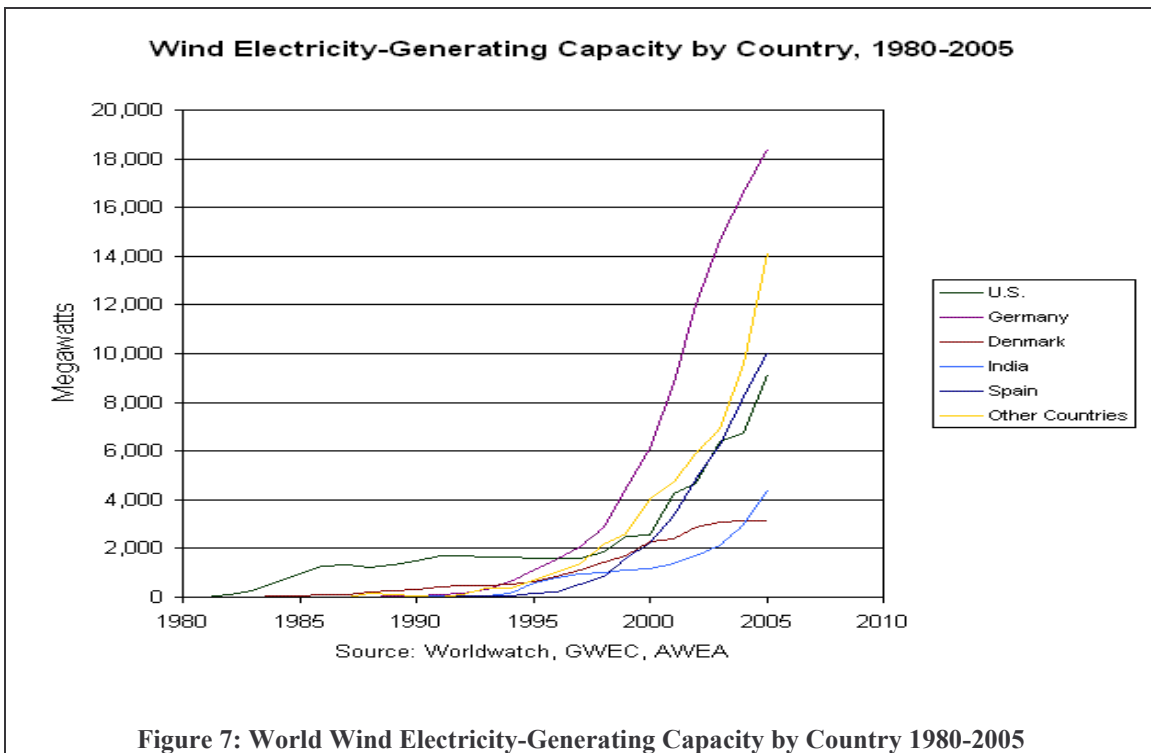

Europe can be characterized as the global leader in wind energy, but wind energy companies are beginning to embark on the globalization of the wind energy market. European countries and the United States are among the many other worldwide countries who have experienced substantial average annual growth rates over the past quarter century in wind energy. However, further progress that the industry is capable of rapidly delivering is constrained by barriers such as grid access, political barriers, and administrative hurdles.

1.4 Massachusetts Wind Power

The state of Massachusetts implemented its Renewable Energy Policy Project in 1997 which is to take effect from 2003-2009. “The renewable portfolio standard (RPS) was created by Massachusetts electricity utility legislation.” It specifies that by 2009, 4% of electricity be generated from renewable sources, and then increase 1% per year after 2009.⁷ This renewable energy source increase is depicted in Table 2.

Compliance Year	Cumulative Minimum Percent Renewable Generation
2003	1.0
2004	1.5
2005	2.0
2006	2.5
2007	3.0
2008	3.5
2009	4.0

One of the main proposed sources of renewable energy for Massachusetts outlined in the document is wind energy. Approximately 3.5% of Massachusetts land has sufficient average wind speeds

Table 2: Renewable Energy Increase

and available land for the installation of utility-scale wind turbines. This number excludes areas that have already been developed or identified as environmentally sensitive.

Because wind farms do not require significant areas of land, at most only 0.35% of the 3.5% of available land would be utilized by turbines and associated structures. Included in this 3.5% of land is Bakke Mountain in the Town of Florida, Massachusetts, and the site of the proposed project location.

In Massachusetts, there are several examples of both existing and proposed wind energy projects. Massachusetts has several prime locations for wind development including the hilltops of Western Mass, including Florida and Monroe Massachusetts, in addition to the shorelines and areas throughout Nantucket Sound. Massachusetts Energy is actively involved in promoting the development of several of these wind projects in Massachusetts. The focus of this Major Qualifying Project will be to develop a wind turbine system based on the proposed project in Florida and Monroe Massachusetts, more specifically called The Hoosac Wind Project.

1.5 Hoosac Wind Project

The Hoosac Wind Project is a proposed small wind turbine project in Florida, MA. The project is engineered to consist of 20 turbines on two ridgelines in the northwestern Massachusetts towns of Florida and Monroe. Upon completion, the project will generate 30 mW of energy. The project was initially owned and developed by enXco, a company out of East California, but ownership was sold to PPM Energy for \$40 million in February 2006.

1.6 PPM Energy

PPM Energy is a multidimensional energy supply company which utilizes wind power and natural gas as its main resources. PPM Energy is based out of Portland, Oregon and has completed numerous projects in Oregon, California, Minnesota, Texas, and many other western states. The Hoosac Wind Project will be the company's first project in New England. PPM Energy plans to generate 2,300 mW of energy from wind by the year 2010.

2 Background

2.1 Site Location Assessment

The Town of Florida, Massachusetts is a village on the summit of the Green Mountain range in the northwest corner of Berkshire County. The first settler in Florida was Dr. Daniel Nelson from Stamford, Connecticut, who arrived in 1783. The town was once a boom town; formerly used as the staging site for construction of a tunnel through Hoosac Mountain. It is largely bordered by the Deerfield River and is a succession of hills and valleys containing some of the highest peaks in Massachusetts, resulting in favorable wind speeds for generating wind power. The town has elevations ranging from 1,000 to 2,700 feet. One of the most notable mountains in the area is Bakke Mountain, which has an elevation of 2,566 feet. The mountain was named after Master Sergeant Roald Bakke, who died in the tragic collapse of an oil tower in Texas. His family, headed



Figure 8: Hans Bakke

by Hans Bakke (Figure 8), currently owns a large portion of the land which comprises most of the mountain. The mountain is the scene of wildlife and forest conservation efforts and serves as one of the primary sites of the Hoosac Wind Project. The town is located in Northwestern Massachusetts and is bordered by Stamford, Vermont, and Monroe on the north; Rowe and Charlemont on the east; Savoy to the south; and North Adams

and Clarksburg on the west. Florida is 28 miles north of Pittsfield and 127 miles northwest of Boston. The latitude of Florida is 42.666N and its longitude is -73.011W. The town is about twenty-five square miles and is home to six hundred and seventy six

people, thus having a population density of 27.5 people per square mile, which ranks 333rd in

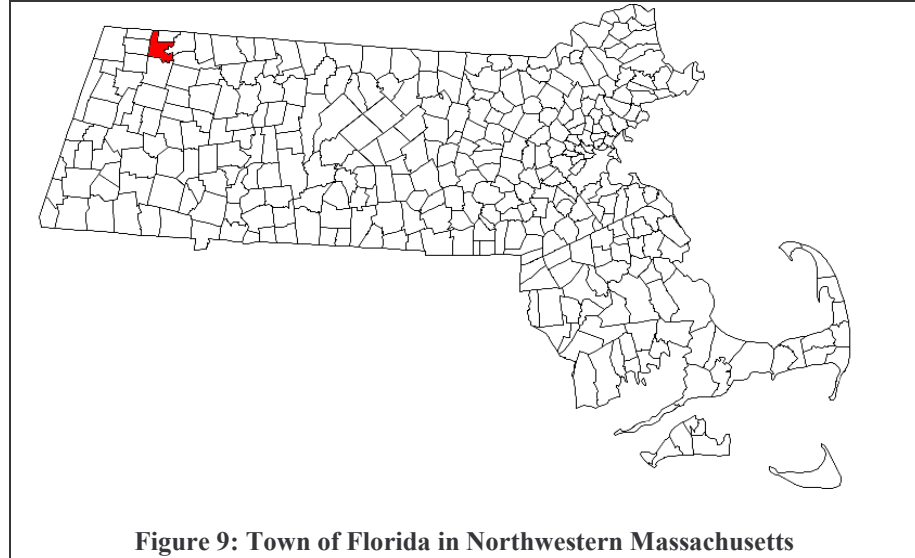

Figure 9: Town of Florida in Northwestern Massachusetts

Massachusetts. The town is highlighted in red on Figure 9.

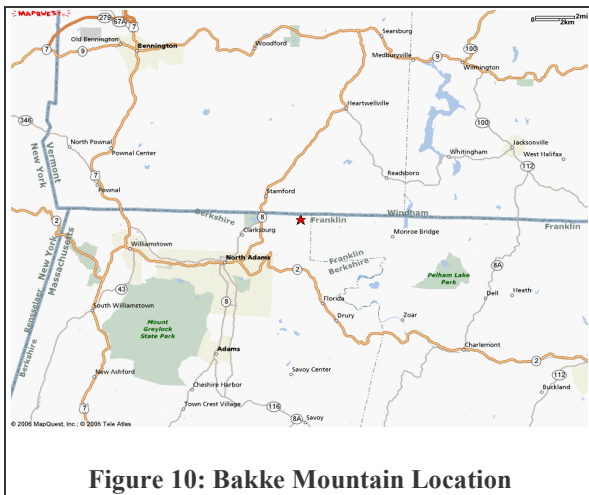
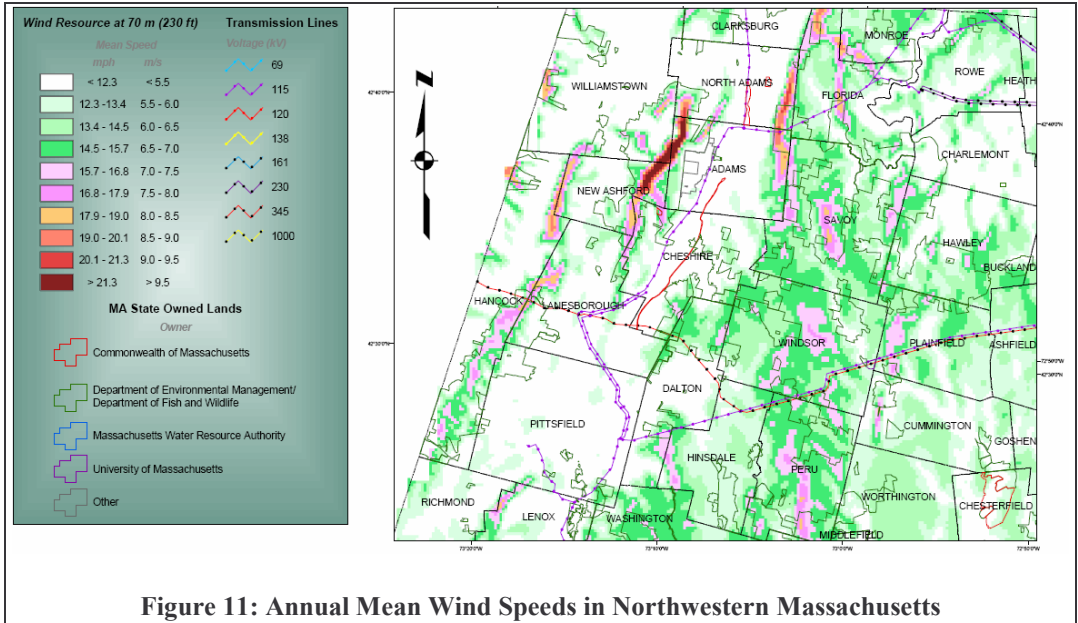

Figure 10: Bakke Mountain Location

The next illustration, Figure 10, maps the exact location of Bakke Mountain in the town of Florida, and is designated by a red star. The proposed wind power plant is to be located on the ridgeline of Bakke Mountain, where the wind speed is most favorable for wind power production. The

wind speed in this geographic location is between 14.5 and 17.9 miles per hour (Figure 11). According to the NSC, (National Science Council) “the ideal wind speed is 22.4 to 25.6 km/h or 14 to 16 mph”⁸ to operate a wind turbine system. Bakke Mountain’s location falls directly within these boundaries as illustrated in Figure 11, a wind resource map of Northwestern Massachusetts. Thus, the proposed location is ideal for the construction of a wind turbine system.

⁸ National Science Council



Here is a computer generated landscape photo of Bakke Mountain's terrain (Figure 12).

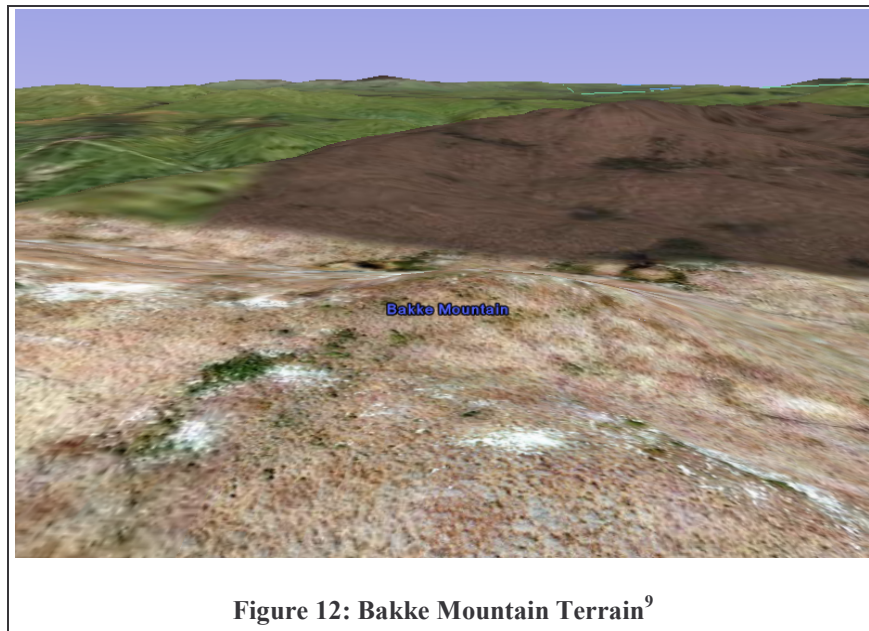

⁹ Google Earth

2.1.1 Environmental Impacts

As with every large construction project anywhere, there are always environmental impacts that will affect the surrounding community's vegetation, and wildlife.

In order to begin the proposed project, a series of permits are needed to begin construction on the turbine power system. This process involves site plan review conducted not only by the local town officials, but also by the Department of Environmental Protection (DEP) to ensure that the project conforms to all the local and state standards mandated by the state of Massachusetts and the town of Florida. Presently, the Hoosac Wind Project is in its second round of appeals with the DEP pertaining to the use of a proposed open bottom culvert design, which would be used where access roads cross over local streams found on Bakke Mountain. The culverts are in question due to the fact that they promote excessive shade and diminish the quality of the sunlight to the surrounding vegetation. The arguments for the appeal stem from the Wetlands Protection Act and DEP regulations upheld by the state of Massachusetts. The second round of appeals is currently before a court judge in Florida, and the owners of this project, PPM Energy, are awaiting the decision.

A local environmental group comprised of a single party of community members, who call themselves "Ten Local Citizen Group," also oppose the construction of the Hoosac Wind Project. The group is backed by a Massachusetts company, Green Berkshires, Inc. based out of Great Barrington, Massachusetts. Green Berkshires, Inc. is the financial supporter for the group and supplies money for all the court appeal fees and charges. Green Berkshires, Inc. protects the foothills and ridgelines of the Berkshires and

all the surrounding ranges. The region is considered part of the Northern Appalachians, and contains the Taconic Mountains, the Southern Green Mountains, and of course, the Berkshire Hills.¹⁰ The official appeal document submitted by “Ten Local Citizen Group” contains arguments based on the Wetlands Protection Act, DEP regulations and issues related to the open-bottom culverts.

In addition to the tributary streams being in the path of the access roads, there appears to be a moderate amount of wetland area around the ridge where the turbines sites are proposed to be constructed. In order to develop the surrounding land an environmentally friendly approach will have to be implemented in order to reproduce all the wetlands that will be affected both during and after the construction of the wind project.

Another environmental issue involved with the proposed wind project deals with the vegetation around Bakke Mountain. One major concern is a native plant known as “goldenrod,” “European goldenrod,” or “*Solidago virgaurea*”. This species of vegetation is native to the land that makes up Bakke Mountain and is protected in the Town of Florida. Goldenrod is a very common wildflower, typically found in meadows and close to the borders of forests. Figure 13 illustrates the goldenrod plant in its natural surroundings.

¹⁰ greenberkshires.org



Figure 13: The Golden Rod Plant

There are over 125 varieties of the plant native to North America and in traditional use goldenrod was used to treat tuberculosis, diabetes, gout, asthma, and rheumatic complications.¹¹ A second plant native to the construction site, which appeared on the state’s watch list, is the mountain wood fern. This particular species is defined as an “uncommon” or “possibly rare” plant. The mountain wood fern is found at the base of ridges near the outcroppings of the lower rock formations. It is also found on the edge of mountain trails that run through the Bakke Mountain and along many of its outlying hills.

One of the more primary environmental concerns is the impact of wind turbines on the local bird and bat populations in the vicinity of the turbine system. It has been theorized that various avian species will fly into and through the wind turbines unknowingly, resulting in the reduction of local bird and bat populations. This concern arose from a large wind farm at the Altamont Pass in California. “In the early 1980s, three major wind farms were built in passes in California. At the Altamont Pass site,

¹¹ ontariowildflower.com

deaths of birds, particularly raptors, prompted a number of studies that subsequently influenced both the design of newer wind turbines and the location of wind farms. It was discovered that raptors perch atop the wind generators for a better view while hunting, and upon rare occasion get caught in the spinning blades when the wind begins to blow.”

¹² The wind farm is constructed of fifty-four hundred turbines closely packed and situated on a major raptor migration corridor. This area is also the location of the highest concentration of gold eagles in North America. The system had a noticeable effect on the raptor populations.

While there is some evidence to support a detrimental bird interaction theory with regards to large wind farms composed of multiple turbines, there is no evidence that a system composed of five turbines spread out over one half of a mile would have a severe impact on the local avian population. In fact, the impact has been stated to be less than one to two birds per turbine, per year. When compared to other man-made structures such as buildings, automobiles, and even domestic animals or natural predators this number is negligible. Current wind turbine technology offers solid tubular towers to prevent birds from perching on them. Turbine blades also rotate much slower than those of earlier designs, reducing potential for collisions with birds. Wind turbine impact on bat populations has not been studied as extensively, but it is theorized that the impact is even lower than that for birds. Conventional fuels used in other forms of electricity-production have a far greater environmental impact due to their pollution of air and water sources.

Recent research has resulted in the conclusion that the entire wildlife population native to the Town of Florida will not be affected by the construction of the Hoosac Wind

¹² powerscorecard.org

Project. There have been extensive studies of migratory bats and avian wildlife that are indigenous to Bakke Mountain. These various studies have all concluded that the project will not have a detrimental impact on any of the native wildlife. However, in order to implement a safety mechanism each turbine tower will be equipped with a night light to provide visual warnings to both avian wildlife and possible airplanes traveling through the area.

2.1.2 Visual Impacts

Besides environmental impacts, a large concern from many of the community members is the visual impacts that will be present when construction of the wind turbine project is complete. Below is a visual simulation of the proposed wind project taken from Stamford, VT on Route 8, looking southeast, approximately 2 miles from the turbines.



Figure 14: Visual Simulation of completed Hoosac Wind Turbine Project

2.2 Construction of Proposed Wind Turbine Power Site

Construction of a commercial-scale wind farm takes several steps. The first step, once all permits are obtained, is to build roads that provide access to the site. As the access roads are being built, construction workers bury electrical cables along the ridgeline between the planned turbine pad locations to the point of interconnection with the overhead utility lines. Once the access roads have been built and the transmission lines have been buried in the ground the concrete foundations for the turbines are formed and constructed. Next, the turbine components are delivered to the site. It takes about eight tractor-trailers to deliver each turbine due to the size of the large components. A large crane does the turbine assembly and each turbine takes about one day to build.

The project construction can be divided into three phases: civil infrastructure, electrical infrastructure and turbine installation. The installation of civil infrastructure involves the construction of access roads, crane pads, lay down areas, foundations, the operation and maintenance building and the meteorological tower. All aspects of the civil work will utilize similar equipment and site restoration techniques. The electrical infrastructure associated with the project consists of underground and overhead electrical collector systems, the sub-station and the transmission lines. The turbine installation will involve the delivery, assembly, installation and commissioning of the wind turbines.

2.3 Local / Access Roads and Turbine Pads

In order for equipment and personnel to reach the construction sites there must be a connecting road system leading from the local existing Tilda Hill road to the five different wind mill construction sites. In addition, there will also be an inter-turbine road

that connects each individual turbine site to the others. This type of road is often referred to as a turbine string road. This road system must be adequately constructed to support large tractor trailer trucks carrying the turbine parts to the sites.

Many of the parts, such as the turbine blades and the tower components are extremely long and will require a wide turning radius for the long cargo trucks to maneuver around the turns. Once construction is complete, the access roads are made permanent. The purpose of the access roads is to provide access for maintenance workers and operators to each of the elements in the system. Permanent access roads are necessary to navigate to the wind turbines, the meteorological tower, the substation, and the operation and maintenance building; they will be substantially narrower than the temporary access roads. Additional temporary access spaces need to be constructed for an on-site concrete batch plant, a transportation opening for the construction cranes and for the entire construction vehicle parking during the entire construction phase of the project. These spaces would also accommodate any pieces of the turbines that need to be stored during the construction phase as well.

Each construction site needs to be designed in order to accommodate the construction of the wind turbines. Level grade will need to be established in order to form a suitable platform for the crane to be stabilized upon. An area adjacent to the wind turbine will be prepared to support the heavy lift crane. This crane pad, which will have similar construction requirements as the access roads, may be removed once the turbine is installed, in order to return the land to its original use. The crane pads encompass an area of approximately twenty-five hundred square feet.

Additional lay down area will also have to be constructed for the cranes to efficiently assemble the massive turbine components. There will be an area immediately adjacent to the foundation, which may be cleared to enable the turbine components to be unloaded and stored prior to installation. These lay down areas will be approximately twenty three thousand square feet and must have specified capacity and grade to allow the components to be unloaded and stored.

In order to reduce costs as much as possible, it will be useful to design roads to form to the existing contours of the area. However, it will be necessary to stay within the limits of the safety specifications, which are listed below:

- Maximum access road slope of 10 percent
- Maximum road slope between turbines (inter-turbine road) between 7-10 percent
- Maximum road width of 50 feet
- Finished gravel access road width less than 20 feet
- Minimum turn radius (inside of roadway) of 115 feet
- Road Surface shall be gravel and able to support max axial load of 20,000 pounds

There is a specific sequence of events that take place in the construction of the access and turbine string roads when developing a wind turbine power site. Site access and turbine string roads will generally be constructed first by staking out a centerline based on initial surveying and land layout techniques. Once the stakes are laid out necessary stabilization features are placed on site including silt fences, straw bails and additional wooden stakes along the limits of construction.

The roadway construction begins with all clearing and grubbing of the natural vegetation in the direct path of the associated access and string roads. This involves moving all local vegetation and trees to allow for the heavy tractors and equipment to establish a grade for the access roads. Once the topsoil is removed it will be separated and then stockpiled for later use. Following the initial grading of the roads, the sub grade is compacted, the geo textile fabric is laid down and the necessary aggregate lifts (2) are assembled and compressed to 95 percent compaction; forming a gravel road surface capable of withstanding heavy construction loads. Once the roads are complete, areas around the constructed road will be returned to there previous states, and final stabilization and methods of re vegetation will be implemented. Following this process all temporary stabilization methods are removed and taken off site.

Often in the process of road construction, a method of cut and fill is implemented before construction to calculate an estimate of the soil that will need to be brought either to or from the site to complete the construction of the roads. This is done in order to maximize the native soil onsite and minimize the cost of hauling excess soil away from the site or trucking in additional soil.

2.4 Construction of the Wind Turbine Foundation

The foundation of the wind turbine provides an anchoring platform that will be the sole stabilization of the apparatus. The wind turbine will be able to resist the forces caused by the wind and the rotation of the turbine blades with the use of an adequate foundation design. A large amount of earth excavation is necessary to complete the construction process of the turbine foundations. Much of the excavated material, however,

will be used to backfill in and around the foundations themselves. This will reduce the need for removal or relocation of the excavated material.

For this particular wind project the design system for a spread or mat foundation will be used. The specifications of the foundation require wide and shallow excavations for the construction of the structure. All the foundation systems must be designed using the information gathered from a geotechnical investigation.

Located at the top of the foundation is the turbine base. The base consists of a metal ring and a series of anchor bolt connections to plant the foundation to the bottom of the wind turbine tower. The turbine base is connected to the concrete reinforced structure using large bolts that are imbedded into the foundation at a specific embedment depth. An electrical earthing mat is typically cast in place when the concrete for the foundation is poured. The casting and the subsequent backfilling of the foundation is typically done prior to the delivery of the wind turbine tower to allow lowest sections of the wind turbine tower to be placed.

All pertinent steps for the foundation assembly are listed below in chronological order.

1. Survey/Stake Site
2. Clear/Grub Site
3. Perform Site Grading
4. Rock Removal and Blasting
5. Excavation
6. Install Below Grade Raceway for Power Cable Equipment (Conduit, Duct Bank, Trench, etc.)

7. Install Below Grade Grid Mat
8. Install a Sub-Layer of Crushed Rock Surfacing
9. Backfill with Required Aggregate
10. Install Foundations
 - a. Place Rebar
 - b. Place Turbine Base
 - c. Place Forms
 - d. Pour Concrete

It is important to note that an extensive geotechnical investigation must be conducted prior to any construction. If excavated soils do not match the required specifications of construction for the turbine then the materials will be placed back into the ground and compacted until reaching the state at which they were prior to the excavation and a new site is located.

A geological and wetland map of Franklin and Berkshire County shows that crystalline bedrock, mostly igneous and metasedimentary rock lie beneath the project site. The site soils are a mix of Lyman and Tunbridge. During the final design and construction of the turbines, the soil type and bedrock will be considered in order to determine the proper foundation support for the turbines.

2.5 Wind Turbine Transportation to Florida, Massachusetts

Transportation on major roadways will be applicable to this project in order to deliver the turbine components to the access roads. The pertinent roads that will be necessary travel routes for the proposed project are Route 2 (Mohawk Trail) and Tilda Hill Road. Initially, it was believed that the Route 2 / Tilda Hill Road intersection would

be modified to accommodate construction vehicles and the turbine delivery. However, one of the residents whose property is located at the intersection of Tilda Hill Rd and Route 2 is willing to allow all construction traffic that requires a larger turning radius at the intersection to utilize their driveway as a means of travel whereas no reconstruction of the intersection will be necessary to transport the components to the construction site.

Transportation of materials to the project site will be a time consuming and labor intensive task due to the large size of the wind turbine components. The first task will be to offload the windmill components from rail cars from the local railroad to trucks for transportation west along Route 2, then approximately 7.5 miles up Florida Mountain for final installation on Bakke Mountain.

The initial unloading site will be on the south side of Rt. 2 near Tilda Hill Road. From there the trucks will travel approximately 5 mph from the unloading site to the installation site. The trip will take approximately two hours. Such a slow speed is necessary because the trucks carrying the turbine components are twice as long as a typical semi-trailer truck and weigh twice as much. Fully loaded the trucks weigh up to 195,000 pounds, which is double the amount seen on a typical semi truck. During the transportation phase trucks carry eight different loads to the site a day, every other day except for weekends, with no trips taking place after dark. On average each turbine takes eight truck trips to transport all the components, and a total of forty to transport five complete turbine setups. Due to the massive size of the trucks significant road closures will be necessary to complete this work and coordination and details will have to be provided by either Mass Highway or the wind project developer.

Public road transportation will require large tractor trailer trucks and extremely large oversized loads. For the transportation of the components of the turbine and turbine tower, a 135' tractor-trailer will be necessary for carrying a single 116' wind turbine blade. The tractor-trailer's loaded height is 14', the number of axles is five, and the span between the two central axles is 98'. There is no driver at the rear, and the turning radius is 120' 7", which will be crucial in the access and string road designs.

There are also specifications for the trucks that will transport other large tower parts. The overall truck length is 112' with 11 axles, the loaded height is 15' 4", the width is 11' 6", and the gross weight is 197,000 pounds. The turning radius is 111' 3". All of the axles are grouped thusly, from front to back: one with a load of 12,000 pounds; three spaced 4.5' apart (axle to axle) for a maximum of 45,000 pounds; two at the same interval for a total of 40,000 pounds; three with the same intervals and a maximum of 60,000 pounds; and the rear two, same intervals, totaling 40,000 pounds. These loading constraints will be vital in construction of the roadway and also in the amount of cover necessary over any culvert or stream crossing design to maneuver over various small streams and creeks flowing down the mountain along the path of construction.

2.6 Wind Turbine Components

Of the many wind turbine models used in various locations around the globe, most operate in a similar way and have components that serve similar functions. Figure 15 shows the major working components that a typical wind turbine contains.

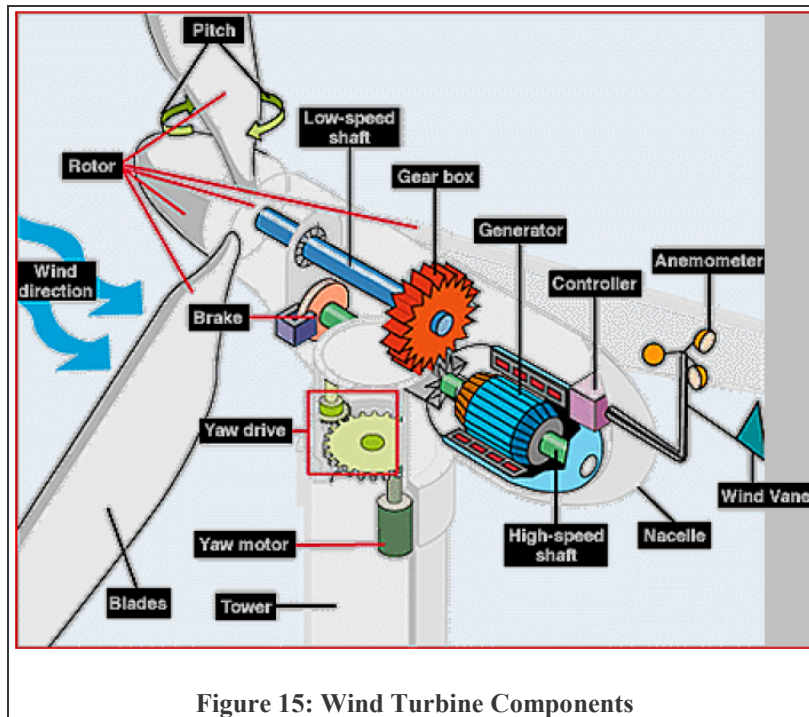

Figure 15: Wind Turbine Components

2.6.1 Rotor

The rotor is the turbine component responsible for collecting the energy that is present in the wind and transforming that energy into mechanical motion. As the overall diameter of the rotor design increases, so too does the energy that the rotor may extract from the wind. Therefore, turbines are often designed around a certain size rotor diameter and the predicted energy that it may remove from the wind in a given application.

Two aerodynamic principles are the basis for the rotor design. They are lift and drag. Drag design rotors operate on the principal of the wind moving the blades out of the way in effect directly exerting a perpendicular force on the rotor; setting the rotor into motion. Drag designs have slower rotational speeds but high-torque capabilities, making them ideal for lower wind speed applications. With lift design rotors, the blades are designed to function like a wing. In lift applications, each blade is designed as an airfoil,

causing a lift force as the wind moves past the blades. The airfoil operates on the basis of Bernoulli's Principle where the shape of the blade causes a pressure differential between its upper and lower surfaces. This difference in pressure causes an upward force that lifts the airfoil. For a wind turbine this lift causes the blades to rotate thus transforming the energy in the wind into mechanical motion.

The design of the individual blades also affects the overall design of the rotor. Since the blades require a fairly smooth airflow to perform properly, the blades must be strategically arranged around the axis of rotation so that they cause the minimum amount of turbulence to the airflow of adjacent blades. It is for this reason that most rotors have only two or three blades.

2.6.2 Yaw Drive

The Yaw Drive is a component of the turbine which allows the rotor to rotate in the direction of the prevailing wind so as to optimize the wind speed by orienting the blades into a position facing directly against the wind current. The Yaw system can be operated from the monitoring facility based on the wind direction at any given time.

2.6.3 Transmission

Due to their huge diameters, the rotors of large scale wind turbines tend to have slower rotational speeds. In most cases, these speeds are insufficient to operate their generators at peak efficiency (for most generators, somewhere between 1200-1800 revolutions per minute (rpm)).

The solution is to insert a gear-box transmission between the rotor output shaft and the generator input shaft so that that rotor speed can be geared up to the appropriate

rpm for maximum power generation. This is also illustrated in Fig. 14, showing the gearbox containing the gears for the low speed and high speed shafts. Wind turbines with smaller rotor diameters may not need a transmission between the rotor and generator. A decrease in rotor diameter results in a smaller arc-length that the rotor must travel per revolution. Ultimately, this causes a comparatively larger rotational speed than that of a larger rotor for a given wind speed. If these larger rotational speeds are appropriate for the type of generator being used, the rotor may be connected directly to the generator resulting in a Direct-Drive system. These systems tend to be simpler and require less maintenance; however they require a larger generator in order to produce voltages comparable to that of AC power. Therefore, Direct-Drive systems are predominately used in DC applications (Battery charging, etc).

2.6.4 Generator

The generator is the component of the wind turbine responsible for converting the mechanical motion of the rotor into electrical energy. There are many different types and sizes of electric generators for a wide range of applications. Depending on the size of the rotor and the amount of mechanical energy removed from the wind, a generator may be chosen to produce either AC or DC voltage over a variety of power outputs.

There are two major steps which characterize the generation process. The first is the actual conversion of the mechanical energy to electrical, for which we employ either one of the generators mentioned previously. However, the raw output of these generators is highly irregular with voltages and frequencies that may vary tremendously and are referred to as being “wild” in nature. Therefore, a second critical step is used where the output from these generators is regulated to a fairly constant voltage and frequency

before it may be utilized in any sort of an electrical application. To accomplish this, there are power processing devices that take the generated output and produce a specific voltage and frequency.

2.6.5 Tower

One of the most important pieces of the wind turbine assembly is the tower that it is mounted upon. Mounting a wind turbine on the highest possible tower results in increased power production due to the stronger winds present at higher altitudes. In addition, the effects of the wind shear caused by the surrounding terrain is also much less at higher altitudes, providing yet another reason to mount the turbine as high as possible. Of course, there are some limitations for the height of a tower in a given application. One such consideration is the structural requirement necessary to support the turbine being considered, including how much the turbine weighs as well as what types of environmental forces (high winds, snow, and rain) it will have to sustain over time.

Zoning regulations may also play a role in dictating the maximum allowable height that the turbine assembly may be elevated off the ground. There are many different types of towers available for a wide variety of turbine sizes to fit any application worldwide.

Due to its immense foundation, located almost entirely underground, tube towers are extremely sturdy structures that can withstand the strongest forces. While not possible until today's modern manufacturing and engineering practices, tube towers have engulfed the entire wind industry and it is rare to see a turbine of any appreciable size erected that is not situated so.

2.7 Wind Power Plant Layout

In addition to the access roads and foundation construction for the erection of the wind turbines and tower assembly, wind power plants contain other components that are necessary for proper operation. Figure 16 provides an illustration of the components that comprise a typical wind energy project and how the individual parts of the system are arranged. Groups or rows of wind turbines are positioned for optimum exposure to the prevailing winds while accounting for terrain variations. Inter-turbine spacing is selected to maximize production while minimizing exposure to damaging rotor turbulence. Inter-turbine and inter-row spacing vary as a function of the rotor diameter and the wind resource characteristics. Because wide spacing between turbines generally maximizes

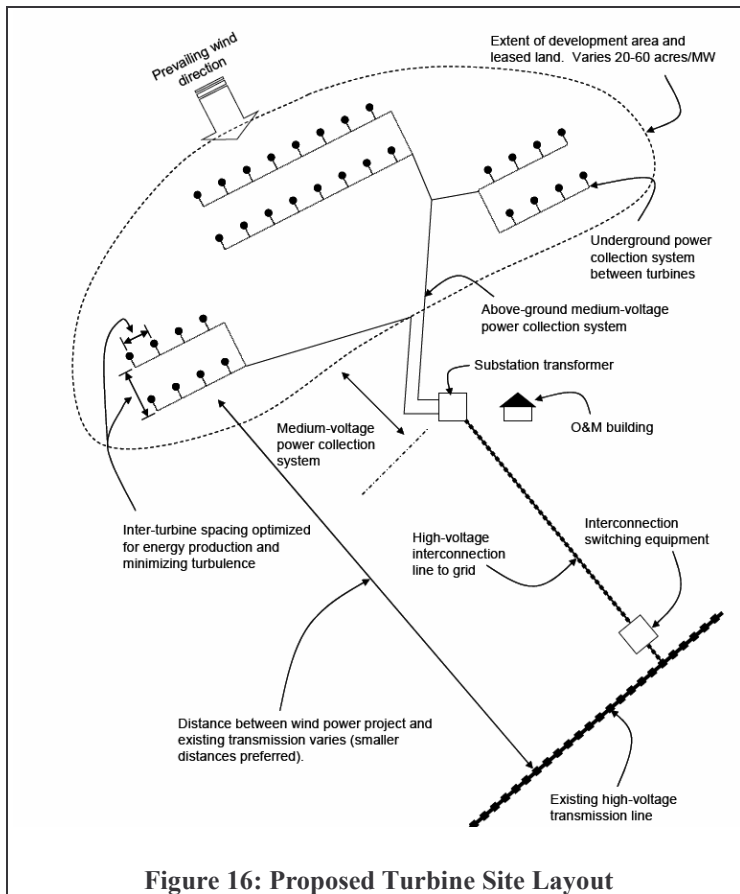

Figure 16: Proposed Turbine Site Layout

energy production but increases infrastructure costs (i.e., land, cabling, and road building), the total pricing must also be considered when determining the layout of a project. A trade-off exists between optimizing the turbine location for energy production through wider spacing and maintaining reasonable turbine interconnection costs, which

increase with wider spacing.

Site visits, mathematical analysis, and cost considerations are implemented into the determination of an optimum setup given all of the existing site conditions and proposed turbine equipment. The majority of civil and electrical work required to design and construct a wind power plant is similar to the activities for other power plants.

2.7.1 Operation and Maintenance (O&M) Facility

O&M facilities for wind power plants generally consist of an office and maintenance shop. These spaces are located on site, usually in close proximity to the wind turbines. An office is necessary for plant management staff, control computers, and communication systems. The maintenance shop is used to store vehicles and spare parts, and provides a work space for the repair of turbine components.

2.7.2 Control and Communications System

In addition to individual turbine control systems on each machine, a wind project typically includes a Supervisory Control and Data Acquisition System (SCADA). SCADA systems consist of a central computer with control capabilities for individual turbines and the ability to collect, analyze, and archive time-series data. Communication cables, connecting the central computer with the individual turbine controllers, are commonly buried in the same trenches as the electrical collection system.

2.7.3 Electrical Power Collection System

For a typical wind turbine system power transformation may take place in several stages in sequence. The starting point is at the rotor where the wind power is harnessed and converted into electrical energy through the generator. For the Hoosac Wind Project,

$$P_{loss} = RI^2$$

**Equation 3:
Power Loss**

electrical energy produced by the GE 1.5 mW turbines is via a three phase generator operating at a voltage of 690 V. Next, the power is sent through a pad-mounted transformer, which is typically located at the base of the turbine tower, to step up the voltage while decreasing the current to minimize the power loss in the lines along the path to the substation. Also, these pad-mounted transformers are used to transform the low-voltage power produced by the turbine to the higher voltage of the on-site electrical collection system. At the transformer, the voltage is stepped up to a 34kV collector system. To minimize cable size, cost and electrical losses the underground system will connect to a double circuit 34.5 kV line. The voltage is increased and the power losses in the lines are given by the following equation:

$$I = \frac{P}{V}$$

Equation 4: Current

This equation illustrates the fact that power losses are proportional to the resistance of the wire and the square of the current. Due to this relationship stepping up the voltage in the transmission lines will result a lower current and ultimately lead to more power. Once the energy is produced from the turbines and collected in a medium-voltage power collection system (34.5 kV), the power is then conveyed to the substation and transformed into a voltage of 138 kV, which matches the power in the local grid. This increase in power is performed by another step up transformer. This system typically consists of below-ground cabling within the turbine rows and above-ground power lines

from the turbine rows to the main substation and then to the local utility grid as shown in Figure 16.

The interconnection point to the utility line can be co-located in the substation or it can be physically separated and located adjacent to the utility line. In general, wind energy projects are positioned within 1 to 10 miles of the high-voltage transmission line to minimize costs associated with the interconnection. However, greater distances may be economically feasible if the wind resource is sufficiently high.

2.7.3.1 Underground cable system

As noted previously, the 690 volt/34.5 kV transformer for each wind-powered generator would be mounted on a concrete pad adjacent to the base of the tower. The concrete foundation for a pad mounted transformer typically would be about five feet by five feet and would be approximately five feet from the base of the turbine tower. The exact distance from the tower base would be determined once the final tower foundation design was in place. Most likely, the pad would be located near the tower access road and would be part of the area disrupted by construction of the tower and road.

The 34.5 kV side of the transformer at the foot of the turbine tower would be connected to three underground collection system cables that would run to the overhead collection system. The overhead line would proceed directly to the proposed interconnection substation near the east end of the project area. The underground collection system lines are likely to run adjacent to access roads, but the exact path of any particular collection line between turbine towers cannot be determined until the actual construction on site takes place. Some flexibility in routing the underground collection system lines is necessary. The reason being the best place to bore may be found under

streams or the best route to avoid disrupting crop growth is on or along the access roads. These measures can be determined and implemented into the construction scheme once the construction phase is in progress.

Each circuit, consisting of three cables, would require a trench about 12 inches wide backfilled with suitable materials. In places where multiple circuits run parallel to one another, four feet of separation between circuits may be required. Thus, two parallel circuits would require a total of six feet of spacing between them. This entails two 12-inch spaces plus four feet of separation. This is referred to as a construction “Right of Way”. The construction utility path would be about eight feet wide, to accommodate the trenching machine and a lead vehicle with the reel of cable. The trench installations would end at the junction of any additional cables or at the risers at the utility poles.

In general, the underground collector cables would connect a series or string of turbines. As the collector system runs along the string of turbines and more energy input enters the collector system, the diameter of the cables would increase, as well as the ability to carry current. The more turbine outputs collected, the greater the diameter of the underground collector cables. From that turbine to the westernmost proposed transfer point, it may be reasonable to have two parallel sets of three-cable systems. The three-cable (single circuit) underground collector systems from the string could be joined to the overhead system at one riser pole. One string of cable collectors would need to be routed directly into the substation near Tilda Hill Road.

2.7.3.2 Junction and riser the transfer locations

At certain points in the collection system, the electricity generated by a group of towers would be compiled at a junction. There will be one location where the 34.5 kV

underground electrical collection systems would be brought aboveground through a riser and connected to wood poles, to connect in turn to the overhead 34.5 kV line. The proposed locations of the transfer points are along the end of the proposed access road, at the beginning of the turbine string, and at the new substation near the Tilda Hill intersection. A transfer location could be close to or near the access route, separated by a normal 34.5 kV line spanning between poles, approximately two hundred and fifty feet per span of above ground cabling. A riser pole would be about 45 feet in height and imbedded approximately ten feet in the ground. A span of similar utility poles would lead along the side of the access road to the substation and then to the interconnection point.

Construction for each riser would involve drilling a hole for the wood pole and using a crane to set the pole in place. The remainder of the hole would be filled and compacted, and insulators would be installed on the pole. With the insulators in place, the underground collection wires would be brought out of the ground at the pole and installed through a metal tubular attachment on the riser pole. On the upper portion of the pole, the cables would emerge from the tube, be attached to the insulators, and become part of the 34.5 kV overhead circuits that extend to the proposed substation.

Construction of the transfer point riser structures would require equipment such as a backhoe, a crane, a flatbed truck for material delivery, and crew trucks. The construction area would disrupt an area approximately 50 feet by 50 feet (2,500 square feet). Lay down areas for parts, cables, and utility poles that would be within the overhead line construction path are also necessary.

2.7.3.3 Substation and Interconnection

“A substation is a subsidiary station of an electricity generation, transmission and distribution system where voltage is transformed from high to low or the reverse using transformers.” The word substation comes from the days before the distribution system became a grid. The first substations were connected to one power station where the generator was housed. Each individual substation was only a subsidiary of that single power station.

For the Hoosac Wind energy project, electrical energy produced by the turbines runs at 690 volts and passes through a substation where it is metered and the voltage is increased to match that of the utility grid. For all of the five GE 1.5 mW turbines proposed, transformers will be placed near each assembly to transform the power output into a 34.5 kV underground and overhead circuit. These circuits will in turn feed the local grid. Isolation breakers, power quality monitors, and protective equipment are all necessary components in the substation to protect both the electrical grid and the wind turbines themselves. A system of switches and overhead infrastructure is used to connect the substation to the utility’s power lines. “Substations may be on the surface in fenced enclosures, underground, or located in special-purpose buildings. Substations located within the buildings they serve are particularly a feature of high-rise buildings. Indoor substations are usually found in urban areas to reduce the noise from the transformers, and for reasons of appearance.”¹³ A fence surrounding a substation must be properly grounded to protect people from high voltages that may occur during a fault in the

¹³ http://en.wikipedia.org/wiki/Electrical_substation

transmission system. A substation surrounded by a fence is the most economical way to house this type of power system. Safety precautions are important to an open design.

Transmission lines and substations provide the necessary support to deliver power to customer's load requirements. The transmission system must provide the four basic requirements listed below. These requirements are addressed by the studies of all electrical systems for potential power plant developers:

1. Thermal Requirements – this defines the system capacity to avoid overheating and damaging the equipment or violating safety code clearances.
2. Voltage Levels – the system must maintain a proper range of transmission voltages during various load and generation levels, included under system contingencies.
3. System Stability – this defines the ability of the specific generator and other regional generators to stay synchronized with each other and avoid tripping off line due to faults, power surges, etc.
4. Breaker Duty – this determines the ability of the circuit interruption equipment to remove faults from the system quickly and disallow equipment damage while maintaining system integrity.

3 Methodology

In order to complete this project our team developed and engineered a wind turbine system and its components to produce a 7.5 mW power supply in the town of Florida, MA. There are five vital components that will be analyzed and designed in order to accommodate the prevailing physical and environmental conditions present near and around Bakke Mountain. They are the access roads, the turbine foundations, the O&M building, the electrical system, a retaining wall and the proposed culverts for all stream crossings.

3.1 Turbine Foundation Design & Structural Analysis

The design process for the wind mill foundation is primarily dependant on two things. One; the dead load caused by the mast (tower), the nacelle and blades of the structure and two; the moment force caused by the wind pressure on the structure.

Typically when designing a spread footing foundation, the load from the some element pushes down on the central part of the footing exerting a force. This is true in the foundation of a wind turbine. This downward pressure causes a compressive force along the top of the footing and a tensile force along the bottom of the footing. Concrete is naturally suited to endure high compressive loads, and the concrete footing will endure all the compressive forces caused by the loads. The tensile forces however exceed the tensile strength of the concrete. The concrete must be reinforced in sections of the footing that are enduring tensile forces to increase the tensile strength. The reinforcement that will prevent the concrete footing from failing under the heavy loading conditions consists

of steel dowels or rebar that are assembled into a mesh style mat and cast in place at the bottom of the spread footing where the tensile forces occur.

The loads imposed on the footing must first be assessed to determine the required amount of rebar that will be used to reinforce the footing. The windmill assembly produces a dead load of 376 kips or 376,000 pounds, a figure gathered through research into the existing Bakke Mountain wind project. Additional pressure, caused by the wind, exerts a lateral force on the windward side of the wind turbine unit; in turn causing a moment force at the base of the mast and the top of the foundation. The moment force is used to design the amount of rebar required to successfully anchor the mast to the foundation. An assumed wind speed of 100 miles per hour is used as a design parameter of the foundation; the 100 mph wind speed creates a drag force acting on all the components of the turbine, (mast and rotor blades)¹⁴.

$$Fd = (Cd)(0.5)(p)(A)(V^2)$$

Equation 5: Drag Force

Equation 5 is used to calculate drag force. The equation is derived from the following factors: “Cd” is the drag coefficient, which is determined based on the shape of the object that the fluid (air for wind applications) is interacting with. “p” is the density of the fluid. “A” represents the surface area of the object that the fluid is acting on. Lastly, “V” represents the velocity of the fluid. Multiplying these variables yields the total drag force. A GE 1.5 mW turbine consisting of the following dimensions: a tower height of 213 feet. The rotor blades have a length of 80 feet and an average width of 7 feet. Using

¹⁴ www.windpower.org

the dimensions of the turbine the moment and the shear force that will be transmitted into the foundation is found using the following data:

$$M_u = R_t + F_t = 3210 \text{ ft} \cdot \text{Kips}$$

Equation 6: Moment Equation

$$V_u = F_t = 16209 \text{ lbs}$$

Equation 7: Shear Equation

Using these values a critical shear force can be found using the following equation.¹⁵

$$V_{uc} = \left[\left(\frac{P_u}{4} \right) + \left(\frac{M_u}{2r} \right) \right] \times \left(\frac{B^2 - \pi r^2}{B^2} \right)$$

Equation 8: Critical Shear Force

$P_u = 376$ Kip; the force of the mast and rotor blades

$M_u = 3210$ ft Kip; the moment force caused by the wind on the structure

$B = 42$ ft; the lateral length of the foundation

$R = 10.66$ ft; the distance from the center of the mast to the critical shear line

The critical shear force is created by both the weight of the structure and the moment caused by the wind on the structure. The moment force will create tensile force on one end of the foundation and a compressive force on the other. The section which

¹⁵ Coduto

endures the compressive force is referred to as critical shear area. This area endures both the compressive forces caused by the moment force in addition to as the weight of the structure.

The next step is to determine how much rebar is needed to endure the bending moment on the critical area. To determine the factored bending moment of the critical area, the cantilever distance “L” must be calculated using Equation 9.

$$L = \left[\frac{2B - (C + C_p)}{4} \right]$$

Equation 9: Cantilever Distance

As previously stated “B” represents the 42 foot lateral length along the base of the foundation. The equation is used to determine the cantilever distance for a steel column and plate structure. C and C_p represent the width of the steel column and the width of the steel plate at the bottom of the column. The design requires a 14 foot diameter for the column and a 16 foot diameter for the plate. The resulting cantilever distance is 13.5 feet.

Once the cantilever distance is found, the factored bending moment can be determined using equation 10.

$$M_{uc} = \left[\frac{Pu \times L^2}{2 \times B} \right] + \left[\frac{2 \times Mu \times L}{B} \right]$$

Equation 10: Factored Bending Moment

The required amount of the area of steel “As” depends on the factored bending moment value which is calculated to be 2880 foot Kips. The area of steel can be

$$A_s = \left[\frac{(f'c \times b)}{(1.176 \times f_y)} \right] \times \left[\frac{d - (2.353 \times M_{uc})}{(\phi \times f'c \times b)^{1/2}} \right]$$

Equation 11: Area of Steel

calculated using equation 11.

The new variables are as follows: “b” is the length of the foundation in terms of inches. So, the length of the foundation is converted into inches (42 feet x 12 inches/foot = 504 inches). “f’c” represents the compressive strength of concrete, which is assumed to be 4 Ksi, “fy” is the yield strength of reinforcing steel which is assumed to be 60 Ksi, and “φ” is 0.9 which represents the flexure in reinforced concrete.

The value for the total required area of steel is fifteen squared inches. The type of rebar used in the reinforcement for the base of the foundation is Number 8 rebar. The dimensions of this particular type of rebar consist of a diameter of 1 inch and a cross sectional area of .785 square inches. The total required area of the steel divided by the area of each reinforcement bar yields the total number of bars which is roughly 19.05 bars so 20 bars will be used. The 20 bars run along the span of the foundation in each direction, resulting in a total of 40 bars at the base of the foundation.

Steel reinforcement is also needed to anchor the bottom of the mast to the foundation. The rebar must be able to withstand the tensile forces caused by the moment. The required amount of rebar needed to successfully anchor the mast to the foundation

can be found through using the following equation from chapter 7 of Everard and Tanner¹⁶.

$$L = \frac{(A_s * f_s)}{(\Sigma_o * U)}$$

Equation 12: Legth

As = Area of steel = 0.785 inches²

$\Sigma_o = \pi \times d = 3.141$

fs = 1605 Kips

U = 133 (table 7.2)

The bonding stress is determined through analyzing the moment force caused by the wind. The foundation must endure this moment force which is causing downward pressure into the foundation on the leeward side of the mast while causing an upward tensile force on the windward side of the mast. The total moment force that is calculated initially is equal to 654 ft Kips. So 654 divided by two is the 327 Kip tensile force, which the anchoring bars must resist. The total required length of rebar is 120 feet. This amount will be needed for each side of the foundation to successfully anchor the mast to the foundation. The 120 feet of rebar will be divided into 12 individual bars which will be equally spaced around the circumference of the mast at a radius of 15 feet. Each bar will be a length of 10 feet. It will be necessary for the bar to bend as it reaches the bottom of the footing. This will result in an “L” shape for each individual anchoring bar. The type

¹⁶ Eyerard and Tanner

of reinforcement that this system has been designed for is type 14s rebar. The 14s rebar has a diameter of 1.693 inches and a cross-sectional area of 0.8465 square inches.

3.2 Access Roads

Before construction of the wind turbines begin, access roads must be constructed. The construction roads (also referred to as access roads) run from the existing road to the turbine sites. The access road design must be wide enough so that the large vehicles used for bringing parts of the wind turbine and the crane used to erect the wind turbines are able to travel easily. For this project, the roads must be strong enough to withstand loads of up to 200,000 pounds. In an attempt to try to reduce the environmental impacts due to water run off, the access roads are unfinished roads made up of processed gravel on top of a stabilizing geo-textile fabric. Proper design and construction of the access roads is vital to this project, extra costs will be incurred if there are problems transporting supplies to the wind turbine sites.

3.2.1 Design of Access Roads

It is important that special attention is given to the design of the roads because the whole construction process will slow if they fail. In designing the gravel road, the maximum loads needed to be supported were found. A maximum axel load of 20,000 pounds is what the design parameters are based on. Design of the access road follows the ‘Gravel Road Thickness Design Methods’ manual¹⁷. Factors such as serviceability, maximum allowable rutting depth, seasonal damage, climate region, and base layer

¹⁷ <http://www.epa.gov/owow/nps/gravelroads/appa.pdf>.

resilient modulus all contribute to the design of the access road. A maximum rutting depth of 1.5 inches was chosen due to the fairly dry climate that exists in climate region 3. In performing the design calculations, a base layer with a resilient modulus is 25,000 pounds per square inch was used.

Roads are designed for rutting damage, as seasonal damage is found to be significantly less. For this project, total damage for both seasonal and rutting damage both had to be below a value of one. With this being said, [multiple gravel depths](#) were tested and a 16 inch base layer was found to be sufficient to carry the traffic loads for this

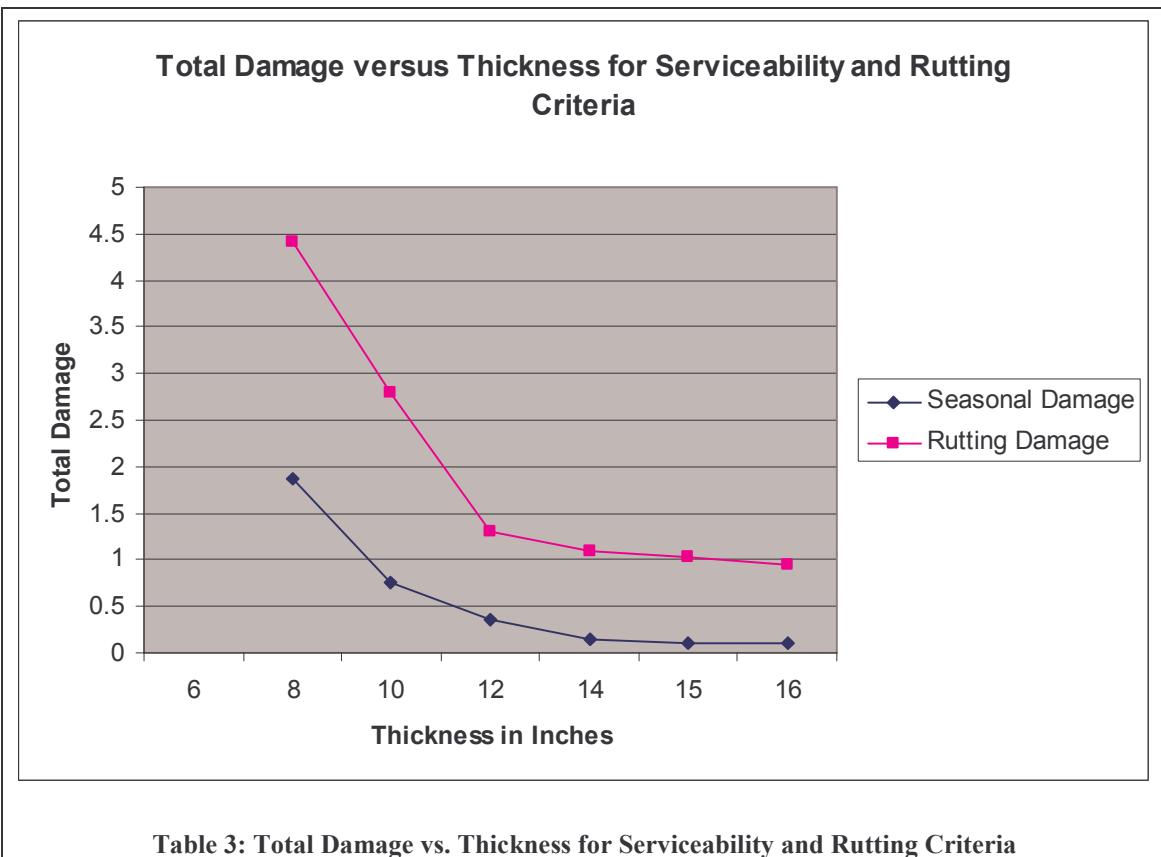

project. Once the 16 inch base layer is chosen, the next step is to split up road thickness into a base layer and sub base layer. Again, multiple trials were done as shown in the [appendix](#). The base layer gravel has a resilient modulus of 25,000 psi, and the sub base

gravel layer will have a resilient modulus of 15,000 psi. Beneath the top two layers a 1 foot layer of compacted sub grade will be placed. The top two gravel layers will be separated from the compacted sub grade by a geotextile separator.

Slopes from the side of the construction road to existing ground will be of at least a 2 to 1 ratio and silt fences will be installed at the side of the main access road to reduce erosion. This specification is in an effort to reduce the rate of water run off that would potentially affect the surrounding area. The inter-turbine road atop Bakke Mountain does not require sloped sides or silt fences, as the water will naturally run down the mountain.

Other issues considered for the construction process are the elevation changes throughout the length of the access road. Maximum allowable elevation of access roads is 10 degrees which is not an issue for this road as the maximum elevation change is between 3 and 4 percent grade.

3.2.2 Clearing and Grubbing

Before the construction of the access roads can begin, the area where the access road will be built must be cleared. This involves clearing trees, stumps, and brush. For this project the forest encountered generally includes brush and small trees with diameters less than 6 inches.

3.2.3 Excavation of Native Soils

In order to make room for the gravel that is to be imported it is necessary to excavate native soil to a depth equal to the depth of gravel to be imported for the width of the proposed access roads. A portion of the topsoil and sub soil that is cut to allow for placement of gravel shall be separated into separate piles and stored on each side of the

construction road. The stored soils will then be replaced over the top of the sloped areas along the 16 foot wide access road. For the purposes of this project topsoil will be considered the top 8 inches of soil, while the next 10 inches below that will be considered sub soil. The bottom foot of soil excavated will be hauled away along with other unneeded topsoil and sub soils.

3.2.4 Construction of Access Roads

Since this is a relatively small wind turbine site and there are only 5 turbines, only one access road will be necessary and each wind turbine site will be branched off of the main access road atop Bakke Mountain. The access road for this project is just less than 2 miles long. The main access road is 1.4 miles long, leading up to the 0.43 mile inter-turbine access road. The main 1.4 mile access road will be a 16 foot wide road with 2 foot shoulders on each side as shown in the [appendix](#) (Type A Access Road).

The inter-turbine road (Type C Access Road) is of the similar design, except the finished gravel road is [25 feet wide](#) to allow for crane movement during erection of the wind turbines. Also included in this road is a utility trench to encase the electrical lines from the individual wind turbines to the upper part of the access road. At the top of the access road the electrical lines then run above ground to the substation.

3.3 Operation and Maintenance Building

The Operation and Management Facility is a vital part of a wind turbine system. The building houses all the equipment necessary for maintaining the system and also is responsible for both the operation and maintenance of the wind turbines and all the related components. The building also contains a monitoring system, which tracks the

electrical production of the wind turbines. Our team created the design of a stick built facility using ASD wood design standards. The building is made up of an office space that contains all the monitoring equipment necessary to operate the wind turbine system and a large maintenance area. The maintenance area is designated for the storage of all equipment necessary for maintaining the site and also for a large space to work on all components of the turbines, which need to be serviced or replaced. The dimensions of the building are forty feet by forty feet. The structure consists of approximately one hundred and twenty five square feet of office and personal space, and fourteen hundred and seventy five square feet of open space for both storage and workspace.

The building has a corrugated aluminum roof and flat panel aluminum siding. There are three openings on the structure; an entrance and two twelve by twelve garage doors.

The design initiated with a preliminary sketch and later developed into a detailed drawing once the structural design is complete. Figure 1 depicts the initial concept of the building which later developed into a detailed structure using ASD wood design techniques.¹⁸



Figure 17: Operation and Maintenance Building

¹⁸ *Design of Wood Structures – ASD* by Breyer, Fridley, Pollock and Cobeen

The initial concept is a square structure which contains a main entrance and two large maintenance bays. The structural assembly has three distinct categories; the site work, the foundation, and the wood structure itself.

Typically, the initial site work entails grubbing, mass excavation, and structural excavation. Once the building construction is complete then all finish landscape and final site development can take place. The building is located approximately an eighth of a mile off Tilda Hill Road situated directly off the access road. The site work for this aspect of the project involves grading approximately one acre of land and excavating in order to accommodate the foundation.

The extent of the structural excavation is a trench five feet deep by seven feet wide with a length of one hundred and sixty feet. Sloped sides are recommended in the excavation process to eliminate shoring of the disturbed soil. Figure 2 shows a typical cross section of the structural excavation and the relevant soil limits.

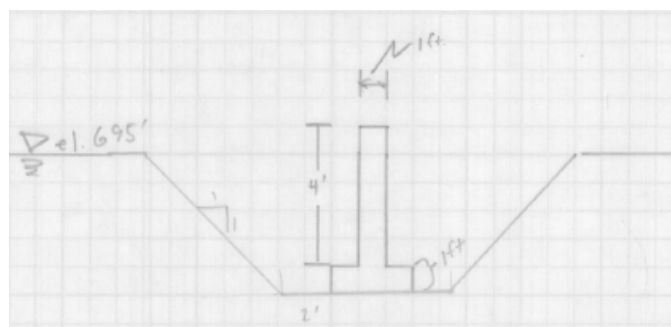

Figure 18: Foundation Cross Section

Removing two feet of soil from the inside of the foundation walls allows adequate space for the components of the poured concrete slab floor, which is constructed after the

foundation is complete. Approximately one hundred and thirty cubic yards of soil needs to be excavated on site for the foundation construction to begin. Once the soil has been excavated the foundation can be constructed.

The first structural component of the building is the foundation. The foundation consists of a four foot high wall which rests on a three foot wide continuous footing that spans around the entire perimeter of the building, depicted in Figure 2. The layout of the foundation is illustrated in Figure 3. The dashed line represents the footing and the solid line represents the foundation wall.

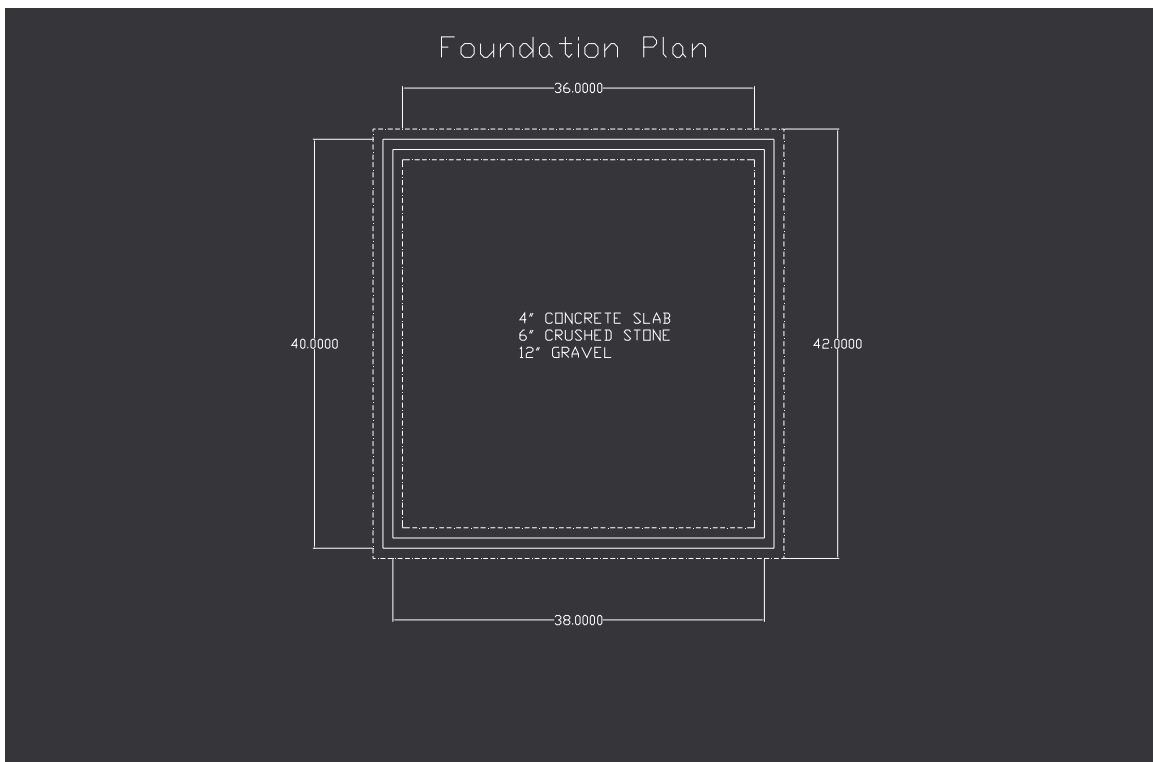

Figure 19: Foundation Plan

The construction of the foundation involves two phases. The first phase will be construction of the footing. First, forms are assemble and secured. Then the concrete is

poured and finished. After finishing, a keyway is created to ensure the proper bond between the footing and the foundation wall. Once all these steps are accomplished then the concrete will need to cure so that the wall can be assembled.

Formwork for the walls will begin only after the footing has been allowed to cure. The foundation walls are four feet high and therefore construction requires four foot forms and twelve inch steel ties to complete the form assembly. Thirteen hundred square feet of forms are necessary for the wall construction. Following the form assembly the concrete is poured and finished and allowed to cure. Once the concrete has cured then the forms are stripped and the foundation is waterproofed and then backfilled using material left over from the excavation. Approximately thirteen yards of excess material remains after the foundation has been backfilled. This soil is either transported from the site or used elsewhere in the construction process.

Roughly twenty four cubic yards of concrete is needed for the construction of the foundation. The footing contains twelve cubic yards of concrete, and the walls also contain twelve cubic yards of concrete.

The four inch thick concrete slab floor rests on six inches of three quarter inch stone above six inches of compacted gravel. The materials associated with the installation of the floor are twenty nine cubic yards of stone and nineteen cubic yards of cement.

Following the construction of the foundation and the slab the wood structure is assembled. The construction of the wood structure is based on the building design which utilized ASD wood structure design standards. The building design is based on two major design criteria; the vertical (gravity) loads and the lateral forces that affect the structure.

The first step in the building design is calculating the vertical loads on the structure. There are three groups of vertical loads. They are the dead loads, the live loads, and the snow load.

The building is located in Florida, Massachusetts which is in Zone number four in the Massachusetts building code. This location is designated design snow load of forty pounds per square foot. The building is a single story structure meaning that the roof, ceiling and stud walls are all taken into consideration when calculating the dead loading. The Table 1 is a list of the vertical loading on the structure:

Load Type	Load (lb per square foot)
ceiling dead load	3.9
roof dead load	4
wall dead load	8.1
snow load	19.6 (horizontal plane)
roof live load	12

Table 4: Load Types

The next step in the design process is calculation of the lateral forces acting on the structure. Seismic forces and wind forces are the two primary lateral loads used in establishing the design parameters for the structure. Using a fastest mile wind speed of one hundred and ten miles per hour the wind load equals 15.4 psf. Using a site class D and categorizing the structure as a category two building the seismic force equals .37 psf. Ultimately the seismic load is negligible when compared to the wind load.

Once the vertical and lateral forces are known then various load combinations are evaluated in order to determine the governing forces on the building.

The various combinations are listed below:

Load Combination	Load (psf)
D	16
D+Lr	28
D+S	35.6
D+W	41.4
D+.7E	16.3
.6D+W	24.4
.6D+.7E	9.97

Table 5: Load Combinations

Where:

D = dead load

Lr = the live load

W = the wind load

S = the snow load

E = seismic load

After evaluating all the loading cases, all design is based on the governing parameters which result in the highest loading combinations. The truss design is designed based on the dead load plus the snow load (D+S). This load combination equals 35.6 psf. The wall design is based on the dead load plus the wind load (D+W). This load combination equals 31.4 psf.

Establishing the governing forces leads to the design of all the different components of the O&M facility. The building is composed of the stud wall, the diaphragm (plywood) the roof trusses and all associated connections.

The structural design involves calculating all associated stresses which result from both the vertical and lateral forces acting on the building. Sizing the structural members involves checking the actual stresses of each member against the tabulated stress values to determine if allowable stresses in all the members are exceeded.

The stud wall design calls for 2 X 6 construction spaced at sixteen inches on center. This is determined by using the interactive stress formula which ensures that the members are supported with respect to both the force due to the horizontal load and also the force due to the vertical load as well. The axial load on each stud is 78.35 psi and the bending load is 914.27. The tabulated stresses (load a particular sized member can withstand) are 427.68 psi for an axial load and 2808 psi in bending. Using the following equation the interactive stresses can be checked to determine whether or not the stud wall has the capacity to withstand both loading types:

$$\left(\frac{f_c}{F'_c}\right)^2 + \frac{fb}{F'b\left[1 - \left(\frac{f_c}{F_cEx}\right)\right]} \leq 1.0$$

Equation 13: Interactive Stress Equation #1

Where:

f_c =actual compressive stress

F'_c =allowable column stress

f_b =actual bending stress

F'_b =allowable bending stress

E_x =modulus of elasticity

F_c =Tabulated bending stress

Using 2X6 Douglas fir larch studs spaced sixteen inches on center gave an interactive stress value of .334 which meets the interactive stress requirement below 1.0, thus the 2 X 6 DFL at sixteen inches on center will be sufficient for the stud wall construction.

The truss design is performed in the same fashion based on the spacing at two feet on center. The axial stresses in each member are calculated using the method of joints and the bending stresses are calculated using the various loading parameters for each individual member. The truss design called for an alternate interactive stress equation.

The equation used is:

$$\left(\frac{fc}{F'_c}\right)^2 + \left[\frac{1}{1 - \left(\frac{fc}{FcEx}\right)}\right] \frac{fb}{F'_b} \leq 1.0$$

Equation 14: Interactive Stress Equation #2

Where:

f_c =actual compressive stress

F'_c =allowable column stress

f_b =actual bending stress

F'_b =allowable bending stress

E_x = modulus of elasticity

F_c = Tabulated bending stress

There are two different truss designs which were designed using this equation, a king style truss and a queen style truss. The queen truss proved to be a more reasonable design due to its uniform 2 X 8 DFL members. The two different truss designs are shown in Figures 4 and 5.

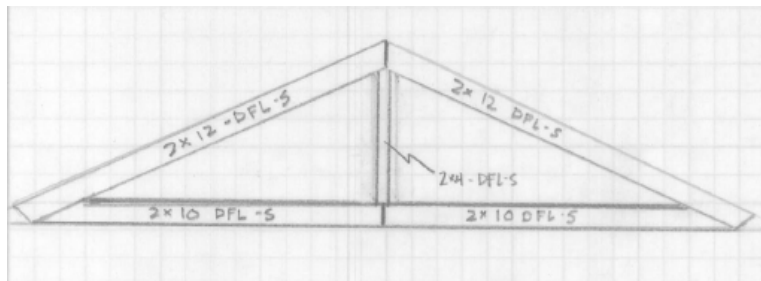

Figure 20: Truss design #1

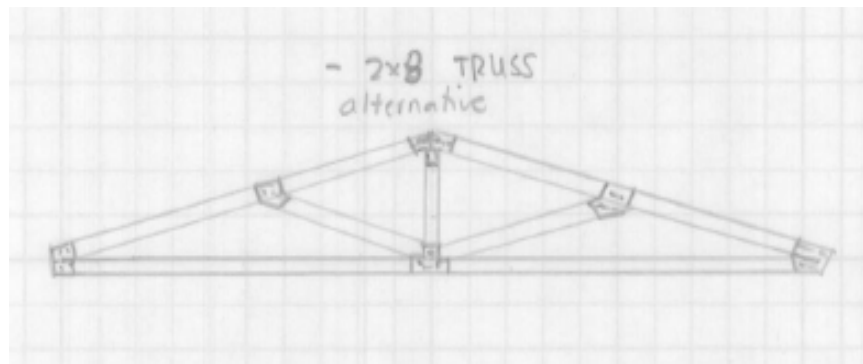

Figure 21: Truss design #2

The diaphragm consists of staggered (common bond) one half inch plywood on the roof and the walls as shown in Figure 22. The nailing schedule is 4 inches on center for all outside edges, six inches on center for all panel edges and twelve inches on center for all field nailing shown in Figure 23.

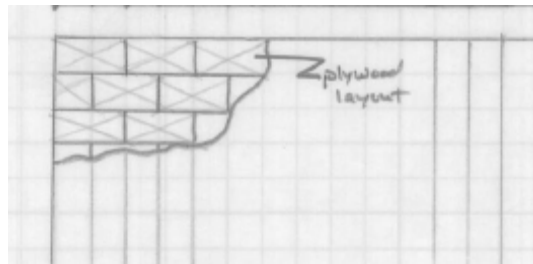

Figure 22: Plywood orientation

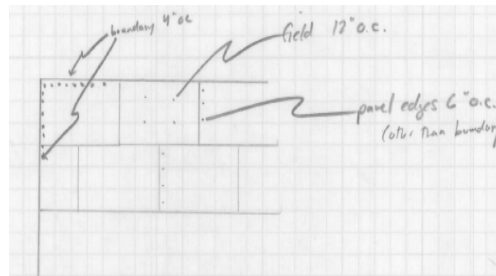

Figure 23: Nailing schedule

The inside of the building serves two distinct purposes. One is to house all the necessary equipment and tools needed to run the turbine system. The other is to provide a small office space to accommodate a monitoring system and a small amount of personal space for the staff that will be working in the building. The office and rest room areas will only take up one hundred and twenty five square feet and will be framed using two by four construction. The rest of the space will remain open so as to provide a sufficient area to work on and maintain the turbines if problems arise.

Below is a table of all the construction items that will be used in the O&M building:

CONCRETE	QUANTITY (CY)	
FOOTING		12
WALL		12
SLAB		19
CRUSHED STONE	QUANTITY (CY)	
SLAB FILL		29
STUDS	QUANTITY (#)	
2X4X8		20
2X6X8		10
2X6X10		10
2X6X16		110
HEADERS	QUANTITY (#)	
2X12X8		2
2X12X14		4
TRUSSES	QUANTITY (#)	
40' PRE BUILT TRUSS		21
PLYWOOD (4X8 SHEET)	QUANTITY (32 SF)	
1/2" PLY FOR ROOF		55
1/2" PLY FOR WALLS		70
TOTAL		
INSULATION	QUANTITY (SF/110 SF)	
WALLS		20
CEILING		15
DRYWALL	QUANTITY	
WALLS (4X8 SHEETS)		80
CEILING (4X8 SHEETS)		54
SCREWS (BOXES)		5
JOINT COMPOUND (4.5 GAL. BUCKET)		2
FIBERGLASS TAPE (ROLL 300 FT)		11
ROOF - CORRUGATED ALUMINUM ROOF	QUANTITY (SQUARE)	
ROOF		17
AIR VENTS		2
TOTAL		
SIDING	QUANTITY (100 SF)	
FLAT ALUMINUM SIDING		23
ELECTRICAL	QUANTITY	
2x4 TROFFER		5
2x2 TROFFER		2
2 WAY SWITCH		4
GFI PLUG		4
.5 KVA SINGLE PHASE TRANSFORMER		1
EMEGENCY/EXIT FIXTURE		1
120 VOLT TANKLESS WATER HEATER		1
SMOKE DETECTOR		2

20 AMP CURCUIT BREAKER	4
FEET OF 12/2 MC	500
CURCUIT PANNEL	1
PLUMBING	QUANTITY(#)
TOILET	1
VANITY	1
PVC PIPING (FLEXIBLE)	150'
DELUX TROFF STYLE SINK	1

Table 6: O&M Components

3.4 Culverts

For all figures (Refer to [Appendix 7.1](#))

3.4.1 Inlet Design

In design of the culverts, it is essential to calculate many properties of the tributary streams involved. A hydraulic analysis of the effected area involves the estimation of a design flow rate based on native climate and watershed characteristics. The hydraulic analysis is one of the most important aspects of culvert design. The hydraulic design of a culvert requires the evaluation of data including culvert location, waterway data, roadway data, and the design headwater for any given flood plane or streambed effected by a roadway crossing.

The first step of the hydraulic analysis of a watershed area is to calculate the flow rate, which will essentially determine the area of the culvert pipe to be used. This is done by using the rational formula, which is shown below.

$$Q = ciA$$

**Equation 15:
Flow Rate**

Where: Q = the flow rate

c = coefficient of runoff

i = rainfall intensity

A = effected area

In order to calculate the flow rate it is necessary to examine the stream bed and local terrain in question. Establishing a point of interest (POI), where the culvert is located, allows for an analysis of the surrounding topography to determine the total area which contributes storm water runoff to the streambed at the culvert location. Once this area is established a land strip needs to be estimated. This strip is a distance from a point furthest away from the POI that contributes storm water runoff to the streambed creating flow in the direction of the POI. Once the strip has been located then that distance, along with the character of the ground as well as the slope of the terrain all can be used to determine the inlet concentration time by using [Miscellaneous Publication No.204, U.S. Dept. of Agriculture Figure H](#) (The Overland Flow Time). After the inlet concentration time is interpolated from [Fig H](#) the next step is to interpolate the rainfall intensity from [Fig. J](#), Rainfall Intensity-Duration. For this interpolation it is necessary to find the one hour rainfall in inches to be expected once in twenty five years using [Fig. G](#) (Intensity Expectation for One Hour Rainfall). Using the inlet concentration time and the one hour intensity expected in twenty five years Interpolation of [Fig. J](#) yields the rainfall intensity in inches per hour.

The coefficient of runoff is attained using [Table B](#) (Values of c) of Miscellaneous Publication No.204, U.S. Dept. of Agriculture. Plugging in the intensity, the coefficient of runoff and the affected area into the rational formula (shown above) yields the flow

rate. Once the flow rate is determined, the culvert pipe diameter can be calculated using the following equation:

$$Q = AV$$

**Equation 16: Culvert
Pipe Diameter**

Assuming a pipe velocity of five feet per second, and using the flow rate determined using the rational formula; the pipe area is equal to the quotient of Q (the flow rate) divided by the velocity (V). This area is then used to determine the pipe diameter. After the pipe diameter calculation, the ratio of the allowable headwater to the pipe diameter is interpolated using the Hydraulic Engineering Circular (HEC) (Exhibit 8-41). This interpolation is used to find a pipe size that produces a headwater depth which is close to the allowable headwater depth attained from the [HEC Exhibit 8-41](#). This process governs the inlet design parameters of the culvert.

Using the inlet design parameters, the next step is to calculate the required depression (fall) of the inlet control section below the streambed. It is important to realize that the velocity head is included in the headwater calculations so the approach velocity head should be deducted from the original headwater to attain the required headwater depth. The following equations are used to calculate the elevation of the inlet at the face of the culvert.

$$Fall = Hwi - Hwd$$

**Equation 17: Inlet Elevation
at Culvert Face**

$$Hwd = Elhd - Elsf$$

**Equation 18: Inlet Elevation
at Culvert Face (2)**

Where: Hwd - design headwater

ELhd - design headwater elevation

ELst - elevation of streambed at face

Hwi - required headwater depth

The fall is calculated first. Then the fall is used to generate an elevation at the face of the culvert (ELi).

$$ELi = ELsf - fall$$

**Equation 19:
Culvert Face
Elevation**

The result is the inlet control of the concrete pipe culvert. Following the inlet design, the outlet characteristics of the proposed pipe must be designed and checked to ensure the pipe will handle the given flow rate.

3.4.2 Outlet Design

The outlet design ensures that the design headwater elevation is greater than the actual headwater elevation. The first step in designing the outlet control is to establish the depth from the culvert outlet invert to the hydraulic grade line. This is done by taking the greater numerical value from the following two equations:

$$ho = TW$$

Equation 20: Tail Water Depth

$$ho = \frac{(dc + D)}{2}$$

Equation 21: Depth of Culvert Invert to HGL



where:

h_o = the depth from the culvert invert at the outlet to the hydraulic grade line (HGL)

TW = tail water depth

d_c = critical depth (interpolated from [Fig III-19](#)---Critical Depth Chart)

D = culvert diameter

Next all the energy losses through the barrel must be obtained by using [Fig III-20](#) (Outlet Control Nomograph) or by hand computation summing all the energy losses. Taking into account these losses the required headwater elevation can be attained, and compared to the design headwater elevation. If the required headwater elevation is less than that of the design headwater elevation than the culvert is sufficiently sized for the given POI and thus it can safely carry the flow generated by the stream.

3.5 Soil Mechanics

It is often difficult to totally understand the way a soil will react under certain loading conditions and given moisture content. Soil is highly unpredictable, and even with the most advanced technology and scientific measurements, nothing is certain; resulting in many codes and standards created by ASTM, AASHTO, and ASCE to prevent disasters from occurring.

3.5.1 Unit Shear and Stress

The equation for calculating unit shear is shown below¹⁹:

$$V = \frac{3 Pxz^2}{2 \Pi R^5}$$

Equation 22: Unit Shear

Where P is the load acting on the soil, x and z are the distances from the point of loading, and R is the direct distance to the point in the soil being measured. Each distance is measured in feet, and the load is measured in kips. Using the equation and the 700 kip load due to the weight of the turbine structure, the unit shear for the soil surrounding the foundation was calculated.

3.5.2 Simple Bearing Capacity

The simple bearing capacity formula allows an engineer to determine the ultimate bearing capacity (q_{ult}) using simple concepts of geometry. Here, S_u is the shear strength

$$q_{ult} = 2 \Pi S_u + \sigma_{ZD}$$

Equation 23: Bearing Capacity

of the soil and σ_{ZD} is the effective stress resulting from the weight of the soil. Assuming the ground water table is extremely deep, the pore pressure in the pertinent area is essentially 0. Assuming the density of the soil to be 100 pcf, and using a soil height of 10

¹⁹ Plummer's Book

feet, a chart can be formulated so as to link the changing internal angle of friction with the changing bearing capacity.

3.5.3 Terzaghi's Bearing Capacity

Another method for determining the ultimate bearing capacity was developed using more realistic geometry for soils and is much more accurate in calculations. The

$$q_{ult} = 1.3c'N_c + \sigma_{zD}N_q + 0.4\gamma'BN_\gamma$$

Equation 24: Ultimate Bearing Capacity

three (3) N's in the above equation correlate to Terzaghi's bearing capacity factors, which can be located in the appendices. The other variables include the effective cohesion (c'), the effective stress (σ'_{zD}), the effective density of the soil (γ'), and the length of the foundation (B). Assuming the effective cohesion to be 1 pcf, a soil density of 100 pcf and ignoring the ground water table again, the equation is very simple. After eliminating the variables, the equation depends only on the internal friction angle of the soil.

3.5.4 Factor of Safety

Soil is most dangerous when it has potential energy. When slopes are not properly held together, there is a recipe for disaster. It is important to determine what precautions, if any, should be taken when building on a slight slope. A simple method to determine the factor of safety of a slope is the "simple slice method". The slope is essentially cut into pieces which are then used to calculate the individual weights per foot of length. This is done using geometry and the unit densities of the soils, if there happens to be more than one soil. The weights along with the internal friction angle, the effective cohesion, and the length of the individual slopes are combined in a table, shown in the

appendices. Some more calculations need to be completed for the last two (2) columns of the table, and then the factor of safety can be determined. During these calculations, some assumptions were made. The soil was a homogenous soil, with an effective cohesion of 100 pcf, an internal friction angle of 30° , a density of 110 pcf, and assuming all heights and angles are accurate. To make the calculations easier, the ground water table was neglected again. The factor of safety is the shear strength of the slope divided by the shear stress.

3.5.5 Compressibility

Now that the soil has been analyzed for structural integrity alone, it is time to understand how a massive foundation, with a 700 kip load on top, will affect the surrounding soil. An easy way to compute the affect is to use the equation shown above.

$$\sigma'_{zf} = \sigma'_{zo} + \gamma_{fill} H_{fill}$$

**Equation 25: Soil
Compressibility**

The density of the fill will be approximately 150 pcf, which corresponds to the weight of reinforced concrete. The effective stress of the soil is added to the weight of the concrete at each depth in the soil. As the depth of the soil increases, so does the effective stress of the foundation acting on the soil. Again, the ground water table is ignored, to simplify the calculations. The height of the foundation is 5 feet and the density of the medium clay is 100 pcf.

3.5.6 Settlement

The problem with constructing a massive foundation with 700 kips resting on top is the settlement due to the immense loading. Soil is unable to withstand such a gigantic

weight. Settlement is expected. Tests need to be done on the soil to determine the cohesive factors C_c , C_r , and e_0 . Using these factors and the equation shown below,

$$(\delta_c)_{ult} = \sum \frac{C_c}{1+e_0} H \log \left(\frac{\sigma'_{zf}}{\sigma'_{z0}} \right)$$

Equation 26: Ultimate Consolidation Settlement

the ultimate consolidation settlement $(\delta_c)_{ult}$ can be derived for the type of soil. Assuming the soil is medium clay with a density of 100 pcf and an effective cohesion stress of 75 psf, the soil is broken down into five (5) or six (6) equal layers. The consolidation is determined for each layer, and the sum of the individual settlements is the final number.

3.5.7 Lateral Earth Pressure

When dealing with slopes and slope stability, attention is brought to the retaining walls. These are necessary when the slope is too steep or when the cohesion in the soil is not adequate enough to keep the slope together. The soil exerts pressure in 360 degrees all around. The equation used to calculate the lateral pressure is seen below:

$$\frac{P_0}{b} = \frac{\gamma H^2 K_0}{2}$$

Equation 27: Lateral Pressure

This equation involves the loading, soil density, height, lateral pressure factor (K), and the width of the retaining wall. Tests need to be completed to determine the internal friction angle and the density of the soil. The lateral pressure factor, K, can be determined using equation 23 from above. Assume no effective cohesion, an internal friction angle of 35°, a soil density of 127 pcf, and an over-consolidation ratio of 2. Again, groundwater was neglected during the calculation process to simplify the example.

$$K_0 = (1 - \sin \phi') (OCR^{\sin \phi'})$$

Equation 28: Lateral

3.5.8 Retaining Walls

Currently there are two (2) types of walls that would fit this project. One is a simple cantilever retaining wall and the other is a counter fort wall. The two walls differ in the ways they are supported. The cantilever wall relies on reinforcing bars inside the concrete to prevent cracking and to support the tension side of the wall, mainly because concrete has poor tensile strength. The counter fort wall has supports on the outside. The wall is shaped like an “L” and has more concrete buttresses built in to support the lateral pressure from the soil. The differences are clearly shown in the appendices. The counter fort wall is far too large to use in this project, therefore the cantilever wall is the logical choice.

3.5.8.1 Assumptions and Estimations

Before the design process for the cantilever retaining wall can begin, some assumptions need to be made about the soil characteristics seeing that no boring logs were taken at the site. Using the surrounding soil as an estimated and educated hypothesis, assume that the unit weight (γ) of the soil is 100 pcf and the internal friction angle (Φ) is 30 degrees. The compressive strength for the concrete used in the retaining wall is 3.5 ksi and the yield strength of the steel reinforcing bars will be 40 ksi. In order to adequately estimate the dimension for the retaining wall, assume that the weight of the concrete is approximately the same as the weight of the soil to make this process simpler. The ground water table is also ignored for simplicity.

3.5.8.2 Original Dimensions

The only dimension that is known to start is the overall height of the retaining wall from the bottom of the base to the top of the stem. The active pressure coefficient, K_a , can be determined using the following equation:

$$K_a = \frac{(1 - \sin \Phi)}{(1 + \sin \Phi)}$$

Equation 29: Active Pressure Coefficient

The resulting answer is approximately 1/3. Then, using the active pressure coefficient and the overall height, the total length of the base of the retaining wall was calculated using the equation seen below.

$$L = 1.5 \sqrt{\frac{K_a h^2}{3}}$$

Equation 30: Base Length

Another educated assumption is made to determine the thickness of the footing to be approximately eight (8) percent of the overall height. The pressure at the base of the stem was calculated using the active pressure coefficient, height of the stem, and the unit weight of the soil. The pressure is equivalent to 245 psf. The horizontal force on the stem caused by the soil backfill was calculated using the following equation, where P_B is the pressure at the base of the stem:

$$H = P_B \frac{H}{2}$$

Equation 31: Horizontal Force

The calculated horizontal force, or shear force (V_B), on the stem is approximately 900 lbs/ft. From this force, a moment was determined. The ultimate shear (V_u) and ultimate moment (M_u) forces on the retaining wall were calculated using the previous numbers and a magnification factor of 1.5. The next dimension needed for the retaining wall is the effective depth of the reinforcing bars, d . The effective depth was computed using the equation shown below:

$$d = \sqrt{\frac{M_u}{\Phi R_u b}}$$

Equation 32: Effective Depth

M_u is 3300 lbs/ft, ΦR_u is 485, and b is 12 in/ft in this calculation. A three (3.0) inch cover is needed to adequately keep the reinforcing bars from disrupting the curing of the concrete, among other problems. The design process shows that the thickness should be increased to the next highest half an inch. The next step is to check the stem for shear stress. The actual shear stress was calculated to be 16.1 psf and the allowable shear stress is 100.6 psf. This concludes that the stem has adequate capacity to withstand the shear from the soil pressure acting due to the backfill.

To estimate the dimensions for the base of the retaining wall, the ground water table and upward soil pressure are disregarded for simplicity. The total force acting down upon the heel of the base is calculated using the area of soil above the heel and the unit weight. The ultimate moment is also calculated around the point on the bottom of the heel farthest from the top of the soil. Rearranging the shear equation results in the following:

$$d = \frac{V_u}{V_{cu} b}$$

Equation 33: Effective Depth

The value for V_u is 1314 lbs/ft, V_{cu} is 100.6 psi from the allowable shear stress previously calculated, and b is 12 in/ft. The result is 1.10 inches for the effective depth. Round up to the nearest whole inch and add three (3.0) inches for cover and another half an inch for the diameter of the reinforcing bar. This calculation only results in an overall depth of 5.5 inches. The minimum depth for the base is 6.5 inches.

3.5.8.3 Overturning Moment

Use all the assumptions already in place. Also assume that the unit weight (γ) of concrete is 150 pcf. The retaining wall and surrounding soil are broken down into four (4) separate areas to be used in force and moment calculations. The total area of each section is found and multiplied by the corresponding unit weights, concrete (150 pcf) or soil (100 pcf). This computation results in vertical forces for each area. The sum of these forces is equivalent to the total shear force acting on the base of the retaining wall (ΣV) which is 2.987 kips. The moments are calculated using the forces just determined and the distance from the middle of each section to a point on the bottom of the base. The point A is on the bottom of the base farthest from the top layer of soil. The sum of the moments (ΣM_A) is 5.158 ft-kips. Dividing the sum of the moments by the sum of the shear forces and then subtracting half the length of the base results in the location of the resultant force. The resultant force needs to reside inside the base to resist the overturning moment. The first time the computation was completed the resultant was less than 0, which means the resultant was located outside the base of the retaining wall. This is unacceptable. The

length of the base was extended by six (6) inches on both sides, and when the same procedure was completed again, the resultant lies inside the base.

3.5.8.4 Sliding

The retaining wall must support its own weight and resist the sliding effects caused by the horizontal force from the soil pressure. If the soil pressure is too great a key can be added to the base to add to the friction force keeping the wall from moving. The shear available along the base is 2.060 kips. This was calculated from the total shear force and the internal friction angle of 30 degrees. Using the following equation:

$$P_p = 5.8 \left(\frac{\gamma H^2}{2 \cos \delta} \right)$$

Equation 34: Soil Pressure

The minimum and maximum sliding forces can be determined. γ is the unit weight of the soil and δ is 2/3 of the internal friction angle. The P_p was calculated to be 2.778 kips.

The minimum force is determined by dividing the shear along the base (2.060 kips) by the horizontal force acting on the stem of the wall (1.536 kips). The resulting answer is 1.341. This number is the one that will govern because it is the smaller of the two. The minimum sliding force needs to be greater than 1.5 in order to resist the horizontal pressure acting on the retaining wall.

3.5.8.5 Reinforcing Steel Bars

Concrete is much stronger in compression than in tension. That is why reinforcing steel bars are placed inside the concrete retaining wall to give it the adequate tensile strength. For the vertical reinforcement, use 2.194 kips as the horizontal force acting a third of the way up on the stem. Using these simple facts, the moment acting on

the stem is computed to be 64.344 in-k. Assume the moment arm from the edge of the stem to the reinforcing bars is 6.5 inches. T is defined as the moment acting on the stem divided by the assumed moment arm. The calculation results in 9.9 kips. To determine the area of steel required in the concrete stem, use the following equation:

$$A_s = \frac{T}{\Phi F_y}$$

Equation 35: Area of Steel

Use 40 ksi as the steel yield strength and 0.9 for the bending magnification factor (Φ). Then go to the reinforced concrete text and look through [Table A-8](#) to find reinforcing bars adequate in size to satisfy the needed area of steel. It is always best to round up to the next highest area to allow for safety. [Table A-6](#) shows the allowable width for spacing of reinforcing bars. Next, check the available moment given from the reinforcing bars. Using the following equation:

$$M_r = A_s F_y \Phi * arm$$

Equation 36: Resisting Moment Force

The resisting moment force was calculated to be 93.6 in-k, which far exceeds the moment acting on the stem (64.344 in-k). The reinforcing bars check out and are adequate to use in the stem. The reinforcing bars in the base are calculated using the same procedure.

3.6 Substation Design

The substation is the central component of the overall wind system where the energy generated by the turbines is collected from all the individual turbines and transformed so that it can be linked to the current electrical grid.

In the substation, incoming lines will have a disconnect switch and a circuit breaker. These devices are used as isolation and protection devices. A disconnect switch is almost always used solely to provide isolation, due to it not being rated for breaking a loaded circuit, while a circuit breaker is often used both as an isolation element as well as a protection device. When and where a large fault current flows through the circuit break can be detected through the use of current transformers. The magnitude of the current transformer outputs may be used to 'trip' the circuit breaker resulting in a disconnection of the load supplied by the circuit break from the feeding point. This seeks to isolate the fault point from the rest of the system, and allow the system to continue operating with minimal impact.

Once past the switching components, the lines of a given voltage all tie in to a common bus. This is a number of thick metal bus bars, in most cases there are three bars, since three-phase electrical power distribution is largely universal around the world. Once having established buses for the various voltage levels, transformers may be connected between the voltage levels. These will again have a circuit breaker, much like transmission lines, in case a transformer has a fault (commonly called a short circuit). In addition, the substation always has control circuitry needed to command the various breakers to open in case of the failure of some component.

A vital function performed by a substation is switching, which is the connecting and disconnecting of transmission lines or other components to and from the system. These switching events may be "planned" or "unplanned". A transmission line or other component may need to be shut down for maintenance or for new construction. For example, adding or removing a transmission line or a transformer while the system is still operating. To maintain reliability of the power supply, the operation never brings down the whole system for maintenance. All work to be performed, from routine testing to adding entirely new turbines to the operation is done while keeping the whole system running.

More importantly, a fault may develop in a transmission line or any other component. Some examples of this would be if a line is hit by lightning and develops an arc, or if by chance a turbine is blown down by a storm with high wind velocities. The function of the substation is to isolate the faulted portion of the system in the shortest possible time and take that faulty portion off of the running circuit.

There are two main reasons why isolation of a faulty portion of the system needs to be isolated. The first reason is that a fault tends to cause equipment damage; and it tends to destabilize the whole system. For example, a transmission line left in a faulted condition will eventually burn down. A second reason is that if a transformer is left in a faulted condition will eventually explode. While these two scenarios are happening, the power drain makes the system more unstable. Disconnecting the faulted component, quickly, tends to minimize both of these problems. Due to these factors Disconnects and circuit breakers are a necessity to a well maintained wind turbine system.

3.7 Power Output of Project

The total estimated power output for the proposed 7.5 mW wind turbine system located in the town of Florida, Massachusetts is based on the use of five GE 1.5 mW turbines running at 99% wind availability, and an operating time of 90% annually. Using a capacity factor of .184 (reasonable power output range) yields a yearly energy production of 2.5 million kWh of electrical power that can be supplied to the local energy grid by each individual turbine resulting in a total energy output of 12.6 million kWh of energy supplied by the entire system annually.

The energy output of the system is given by the equation below:

$$CF = \frac{AEO}{RPO}$$

Equation 37: Capacity Factor

Where:

CF=capacity factor (.20 typical--.19 for Hoosac Wind)

AEO=actual energy output

RPO=Rated power output

Table 7 shows the results for values that represent the most likely costs and financing terms for the Hoosac wind turbine project with no grants and present costs for funding a project. The average rate is based on a blend of equity (12% return) and debt (8% return) financing, for a 20% financing rate. Of that 20%, 50% is paid to the principal and 50% is paid to the interest of the financed amount, resulting in a Fixed Charge Rate (FCR) of 10%.

The cost for the wind turbines (\$850/mW) is the minimum current cost for wind turbines. A price of 1.3 million per turbine for the Hoosac wind project reflects this price. The balance-of-station costs (engineering, roads, control/storage building, wind turbine foundations, monitoring and control systems, one-time installation fee by land owner, and electrical infrastructure cost) generally have a range between \$230.00 and \$280.00 per installed mW. A value of \$270 per mW was used for this calculation to account for the difficult access and rugged mountainous terrain.

Cost of Energy	
Item	Nominal Values
Project Capacity (mW)	7.5
Project Life (years)	20
Fixed Charge Rate *	0.1
Wind Turbine Cost	6,500,000
Balance-Of-Station Cost (@ \$280/kW)	420,000
Transaction Costs (5% of WTC and BOSC)	346,000
Total Capital Cost	7,266,000
Annualized Amortization (FCR * Capital Cost)	871920
Annual Operation and Maintenance Cost**	150,000
Total Annualized Cost	1021920
Annual Net kWh	12,548,700
Cost of Energy (COE) (\$/kWh)	\$0.069
<p>*based on 12% equity return and an 8% debt return for a total of 20% return--- use 50% equity and 50%debt</p> <p>**Includes management, repairs, scheduled maintenance, blade washing, and annualized scheduled replacement/overhaul costs</p>	

Table 7: Cost of Energy

The price of energy for a 7.5 mW wind turbine system located in the town of Florida, Massachusetts would be 6.9 cents per kWh of energy production using the following equation:

$$COE = \frac{(FCR * CC) + AOM}{ANEG}$$

Equation 38: Cost of Energy

COE=Cost of energy

FCR=Fixed charge rate (assumption)

CC=Capital cost

AOM=Annual O&M cost

ANEG=Annual net energy generation

The following table illustrates the feasibility of the project, assuming no grants or federal funds.

Maximum Cost of Energy to Fund a Commercial Wind Project

Item	\$/kWh
payment from utility company (current rate)	0.04
tax credits*	0.018
Total (break even)	0.058

*Federal 1.8¢ per kWh production tax credit (PTC) for wind generated power for 10 years with conditions of renewal

Table 8: Funding Costs

The total cost of the project will be 6.9 cents per kWh to construct the 7.5 mW turbine system in Florida, Ma. According to Table the maximum cost of energy cannot exceed 5.8 cents per kWh in order to break even and cover all capital costs. The gap between the cost to generate the energy and the potential income is 1.1 cents per kWh, however, if funding is provided to finance the project (via low cost financing and/or grant funds), this project could be a profitable venture to the owner.

Findings and Conclusions

1. The average wind resources measured at both sites were marginal, with annual average wind speeds of 14.4-17.9 mph at a 65-meter hub height, and wind shears of 0.08 – 0.13. Using GE 1.5 MW wind turbines with a hub height of 65 meters, yields a net capacity factor of approximately 0.19.
2. The cost-of-energy for a commercial project is estimated at approximately 6.9¢ per kWh using current costs for capital and equipment prices.
3. Economic viability for a commercial wind power station would require a subsidy or grant funding of 25% of the project capital cost to make this a feasible construction project.
4. Because the cost-of-energy from wind power is decreasing, and because there may be small pockets of higher winds on Bakke Mountain, our recommendation is to expand the project, upgrading all old turbines and install new turbines along the entire ridgeline of the mountain after the project life of twenty years.

4 Results & Cost Analysis

4.1 Turbine Foundation

The results for the Wind Mill Foundation are found through using the calculations presented in the Wind Mill Foundation Methodology. The Foundation's function is to provide the wind mill mast, pod and blades proper stabilization against wind forces. To determine the required amount of reinforcement bars in the entire foundation, a simulated 100 miles per hour wind force was used in the design calculations. This wind force provided both an extreme but theoretical shear and moment force that a wind turbine unit would have to endure during its lifetime.

The wind force on the wind mill unit yielded a result drag force of approximately 16 kips. The total moment force due to the drag of the wind resulted in a 3210 ft kip moment force. These were the values that the foundation would have to endure.

The foundation's dimensions were assumed to be a 42 by 42 by 4 foot cube. The concrete used has a unit strength of 4 kips per square inch. The highly compressive resistance of the concrete will successfully support the wind mill unit's weight as long as the foundation has reinforcement along its base. The base reinforcement bars consist of type 8 rebar which has a diameter of 1 inch and a shear unit strength of 60 kips per inch.

Through the calculations found in the Wind Mill Foundation Methodology section the total required area of steel needed to successfully reinforce the base of the foundation is 15 square inches. The 15 square inches is divided into 20 type 8 rebar going in both directions, which results in a total of 40 reinforcement bars in the base of the foundation. To comply with standard foundation construction the re-bars will be placed 3 inches from

the bottom surface of the foundation. Rebar will be spaced approximately two feet apart from one another.

Anchoring reinforcement will also need to be designed. The anchoring reinforcement keeps the wind mill unit firmly anchored to the foundation and keeps the unit from falling over. The anchoring rebar will be a type 14S rebar, which has a diameter thickness of 1.693 inches. The reason for using a thicker anchoring reinforcement bar is to help decrease the amount of rebar needed in the anchoring mechanism. A thicker, stronger reinforcement bar will mean less bars are need to successfully anchor the mast to the foundation. Through using the calculations found in the Wind Mill Foundation Methodology a total of (12) ten foot re-bars.

The total ten feet of each rebar will be completely submerged in the foundation. Each bar will curve at a radius of 8.5 inches outward to form an “L.” These “L” shaped bars will be able to fit in the four foot deep foundation. An additional foot of each anchoring rebar will emerge from the top of the foundation. This section of the bar will be threaded so that the base plate can be securely fastened and welded to the rebar. During the construction the anchoring rebar must be arranged and stabilized while the liquid concrete is poured and set. To accomplish this, two type 14s circular rebar collars will be welded to vertical section of all 12 anchoring re-bars.

The mast of the Wind Mill Unit will rest in the center of the foundation on a 16 foot diameter plate which it will be welded to. The plate will be an inch and a half thick with twelve holes equally spaced at a 15 foot diameter circle about the center. Each of these twelve holes will mate with the top of the threaded anchoring rebar. The holes will be cut at 1.693 inch diameters to fit snugly onto the rebar.

The construction cost of each of the wind turbine foundations consists of the price for the concrete and the reinforcement bars. The total price with both the steel and concrete considered comes out to be \$34,142.36.

The unit price for steel is \$170 dollars per 1 ton. This converts to \$.085 per pound of steel. The type 8 rebar has length weight of 2.67 pounds per foot. The total length of type 8 rebar in each foundation is 1667 feet. This required amount of base reinforcement bars totals up to be \$378.33.

The total length of required type 14s rebar is 120 feet. The type 14s rebar's weight per length is 7.65 lbs per feet. The total amount of weight for all of the anchoring rebar comes out to be 918 lbs. This results in a total cost of \$78.03.

Unit prices for the type of concrete used in this particular foundation project is \$12,890 per 100 cubic yards. Considering this, the approximate 262 cubic yards of concrete in each foundation slab yields a total price of \$33,686 for the required amount of concrete in each foundation slab.

4.1.1 Cost of Turbine Foundation

The total cost for construction of the wind mill foundations is based an estimate of costs for labor, materials and construction equipment. The estimates used for this projection are based on the figures shown in the 2006 National Construction Estimator. The total price for each foundation comes out to be \$56,486.80. In this project there are to be five separate wind mill foundations all using the same spread footing design, so total foundation construction cost results in an amount of \$282,434.

4.2 Gravel Roads

In the design of the gravel roads for this project, three different designs were found to be sufficient to resist the expected loads during the construction of this project. All three options include three layers of aggregate: A base layer with a resilient modulus (Mr) of 25,000 psi, a sub base layer with a Mr of 15,000 psi, and compacted sub grade layer. In all three scenarios the compacted sub grade layer is a depth of one foot. In order to select the type of material that is to be used, A.A.S.H.O. Soil Classification tables were used.²⁰ A.A.S.H.O material A-2-6 which has a typical resilient modulus (Mr) of 26,000 psi was used for the base layer and material A-6 which has a typical Mr of 17,000 psi was used for the sub base layer.

The first design option consisted of an 8” base layer and a 17.5” sub base layer. The second design option included a 9” base layer and a 12” base layer, while the third option consisted of a 10” base layer with a sub base layer of 8 inches. Quantity take offs were completed for each of the different road designs and compared to one and other. It was found that road design option #3 will be the most economical, as there will be less material that will need to be excavated and less aggregate brought to the project site. In comparison, road design option # 3 will require nearly 10,000 CY less excavation and more than 7,500 less cubic yards of imported aggregate. This will save time and money. The complete breakdown of all construction quantities by road design type can be found in [Appendix](#) .

²⁰ Pavement Deflection Analysis, Participant’s handbook, FHWA-HI-94-021, 1994

4.2.1 Costs for Gravel Road Construction

Besides construction costs of the gravel road itself, there are a variety of other steps that must be accounted for in estimating the cost of the access road. Aspects such

- as:
- Clearing and grubbing the area the road is to be placed
 - Excavation and transportation of extra native soils away from the project site
 - Excavation and storage of some native soils on site
 - Replacing native soils stored on site when construction is complete
 - Cost of aggregate
 - Transportation of gravel to the project site
 - Geo textile material
 - Gravel compaction
 - Silt fencing

Clearing and grubbing will extend out 5 feet further than the constructed access road and 10 feet further on each side of the inter turbine road.

For the purposes of this project we will assume that all excavated earth is taken to a quarry 2 miles away from the project site and there will be no charge for disposal, as there is rich topsoil that the quarry can sell. The system used to transport excavated material away from the project site will include five 16 CY dump trailers.

When construction is complete, the sloped sides of the main 1.4 mile access road will be filled back in with native soils that were previously stored on site. This quantity is almost exactly 3,000 cubic yards which will be stored along the outer edge of the access road during construction.