

Treasure Valley Scout Reservation Solar Energy Sustainability Study

August 17, 2015

Authors

Mahir Uğurtan Derman, *umderman@wpi.edu*

Jason Correia, *jcorreia@wpi.edu*

Approved by:

Professor Fred Looft

Electrical and Computer Engineering,
and Systems Engineering



An Interactive Qualifying Project Report
submitted to the Faculty of
WORCESTER POLYTECHNIC INSTITUTE
in partial fulfillment of the requirements for the
Degree of Bachelor of Science

This report represents the work of one or more WPI undergraduate students submitted to the faculty as evidence of completion of a degree requirement. WPI routinely publishes these reports on its website without editorial or peer review.

Table of Contents

- Table of Figures 1
- Acknowledgements 4
- Abstract 5
- 1.0 Introduction 6
 - Energy in the U.S. 6
 - US Electrical Energy Generation and Use 8
 - Sustainability and Photovoltaics 9
 - Scouting and Sustainability 10
 - The Project Site 11
 - TVSR Environmental Conservation Building (ECon) 12
- 1.1 Project Statement 13
- 1.2 Summary 13
- 2.0 Background 14
 - 2.1 Electrical Background 14
 - Volt 14
 - Ampere 14
 - Watts 15
 - Resistance 16
 - Joules 16
 - 2.2 Solar Energy System Basics 17
 - Solar Panels 18
 - Solar Panel Mounting 20
 - Solar Panel Pointing 21
 - Charge Controller 22
 - Storage 23
 - Inverter 23
 - Solar Path Finder 24
 - 2.3 PV Panel Environmental Concerns 25
 - 2.4 Types of Solar Installations 25
 - Grid-Tied 26
 - Off-Grid 26

2.5 Solar Power Financial Incentives	26
National Incentives	26
Massachusetts State Incentives	27
Other Financing Options.....	28
2.6 Scouting Advancement	28
Scout Rank	28
Merit Badges.....	29
Nova Awards	32
2.7 STEM and Education	33
2.8 Educational Theory	34
Maslow’s Hierarchy of Needs	34
Maslow Criticism and Updates.....	35
Federal Aviation Administration (FAA) Perspective	36
Education in the Natural Environment Study	37
The Importance of Peer Learning	38
Educational Theory Summary	38
2.9 Background Summary.....	39
3.0 Methods.....	40
3.1 Educational Planning Methods.....	40
3.2 Solar System Assessment and Planning Methods.....	41
3.3 Methods Summary	42
4.0 Results.....	43
4.1 ECon Energy Needs Assessment Results	43
Lights	43
Heating Rock	45
Refrigerator	45
Cooling Fans	46
4.2 ECon Energy Supply Assessment Results	48
One Line Diagram.....	49
Detailed Electrical Schematics	50
4.3 ECon System Components Assessment Results	51

Panels	52
Mounting.....	53
Tree Removal.....	55
Transmission Line.....	56
Charge Controller.....	57
Batteries	57
Timer.....	58
Fuses	59
Inverter	60
4.4 Educational Results	61
Merit Badges	61
NOVA Requirements.....	70
4.5 Results Summary.....	73
5.0 Project Discussion, Recommendations, and Summary.....	75
5.1 Restrictions to ECon Site Expansion	75
5.2 ECon site ‘Vision’	79
5.3 Development of the ECon Site into a Center for STEM and Sustainability.....	80
5.4 Short-Term Recommendations	81
5.5 Near-Term Recommendations	82
5.6 Long-Term Recommendations.....	83
5.7 Future Project Recommendations	84
5.8 Project Summary.....	86
Citations	87
Appendix.....	93

Table of Figures

Figure 1 - History of U.S. total energy use	6
Figure 2 - Histogram of U.S. energy illustrating different energy sources.....	7
Figure 3 - U.S. energy consumption with an emphasis on renewable sources	8
Figure 4 - Electric consumption flow in the U.S., source to target.....	9
Figure 5 - Basic photovoltaic cell operation	10
Figure 6 - TVSR East Camp with reference to ECon.....	11
Figure 7 - ECon building	12
Figure 8: Alessandro Giuseppe Antonio Anastasio Volta (1745-1827) [13].....	14
Figure 9: André-Marie Ampère (1775-1836) [14].....	15
Figure 10: James Watt (1736-1819) [15].....	16
Figure 11: Georg Simon Ohm (1789-1854) [16].....	16
Figure 12: James Prescott Joule (1818-1889) [17]	17
Figure 13: A solar system with associated components [18].....	18
Figure 14: A thermal solar panel installation [19].	18
Figure 15: Thermal Solar tubes in detail [20].....	19
Figure 16: PV cell in detail [21].....	19
Figure 17: Multiple PV panels mounted on the ground [22]	20
Figure 18: PV panel roof-mounted on a hard shelter roof at TVSR	20
Figure 19: PV panel wall mounted [23].....	21
Figure 20: Solar panel mounting angle considerations [24].	22
Figure 21: Pure Sine Inverter.	23
Figure 22: Solar Path Finder.	24
Figure 23: A SPF survey on a chart.	25
Figure 24 - Scout rank badges [32].....	29
Figure 25 - The Engineering Merit Badge.....	29
Figure 26 - Merit badge sampling.....	31
Figure 27 – William T. Hornaday Medal.....	31
Figure 28 - Eagle Palms.....	31
Figure 29 - Nova Award patch.....	32

Figure 30 - Maslow's Hierarchy of Needs 1954	35
Figure 31 - Modern version of Maslow's Hierarchy of Needs.....	36
Figure 32: Compact fluorescent bulbs [48].....	43
Figure 33 Types of light bulbs compared [49].....	44
Figure 34: 6W LED light.	44
Figure 35: Heating rock	45
Figure 36: Old Emerson refrigerator.....	46
Figure 37: New ECO refrigerator [51].....	46
Figure 38: The old Holmes fan	47
Figure 39: 12V DC fan [52].....	47
Figure 40: One line diagram	50
Figure 41: Electrical schematic of the ECon building	50
Figure 42 Simulated power loss.....	51
Figure 43: Solar setup components.....	52
Figure 44 - 215Watts PV panel.....	52
Figure 45 - Specification sticker on the back of the panel.....	53
Figure 46: Custom made ground mounting equipment for the solar panels.....	53
Figure 47 Solar path finder survey locations	54
Figure 48: Bird eye view of the ECon building site	55
Figure 49: Path of the sun and blocking trees	56
Figure 50: Transmission line trench.....	56
Figure 51: Charge controller	57
Figure 52: 85Ah VMax Battery	58
Figure 53: Timer	58
Figure 54: Instructions	59
Figure 55: Fuses	60
Figure 56: Pure sine inverter	60
Figure 57 - Electricity Merit Badge [54]	61
Figure 58 - Electronics Merit Badge [55]	63

Figure 59 - Energy Merit Badge [56].....	65
Figure 60 - Engineering Merit Badge [33].....	67
Figure 61 - Sustainability Merit Badge [57]	68
Figure 62 - NOVA cub scout module “Science Everywhere” [58]	70
Figure 63 - NOVA Cub Scout module "Tech Talk” [58]	71
Figure 64 - NOVA Boy Scout module "Start Your Engines!" [59].....	72
Figure 65 - NOVA Boy Scout module "Whoosh!" [59]	73
Figure 66 - ECon site area topographic map [60]	75
Figure 67 - ECon site area satellite map [61].....	76
Figure 68 - ECon site looking from East to West	76
Figure 69 - Shading in the East side of the ECon site.....	77
Figure 70 - ECon site with vernal pool [60]	78
Figure 71 - Vernal pool at ground level.....	78
Figure 72 - Envisioned STEM/sustainability center	86

Acknowledgements

The successful completion of this project would not have been possible without the support of the following people and organizations. We would like to thank our advisor, Professor Fred Looft, for guidance at every stage of the project. Thanks goes to Jim Dunn, who donated supplies to our project. We would also like to thank Raymond Griffin from Treasure Valley Scout Reservation for being a dedicated and involved liaison for the BSA's interests, Matt McLaughlin who dropped what he was doing to lend a hand and helped with site development, and to the other stakeholders at Treasure Valley, Thomas Chamberlin, Jeff Hotchkiss, and the Friends of Treasure Valley, thank you for the support and several cups of coffee.

Abstract

The purpose of this project was to perform a sustainability and STEM utilization planning study of the Ecology Conservation (ECon) building and site at Treasure Valley Scout Reservation that included the planning of an off-grid solar installation, and a vision for the development of the site to include STEM and sustainability programs, including solar energy installation, future site development, and educational benefits. The solar energy component involved a plan to provide power to the ECon building for lighting and wildlife habitat support. Visioning for future site development consisted of recommendations for the use of the ECon site as a center for STEM and sustainability education. The educational benefit was focused on merging current BSA merit badge and other requirements with STEM and sustainability programs that could use a solar power system as a medium for education and training. It is hoped that future projects will continue to develop the ECon site into an educational center that incorporates STEM and sustainability education and site development work completed by this project.

1.0 Introduction

Energy in the U.S.

Energy utilities are a modern necessity with many energy-using applications well integrated in our daily lives. Some energy uses such as air conditioning and television improve the quality of life, while other energy uses such as medical applications, communications, and transportation save lives. As a result of the general usefulness of various forms of energy, the demand for energy generation has increased with almost every year that has passed [1]. This increase in demand can be seen in Figure 1 below where the yellow line (top) illustrates energy consumption in the United States from approximately 1950 to present day. The demand for energy has in fact more than doubled in the last fifty years with almost no interruption.

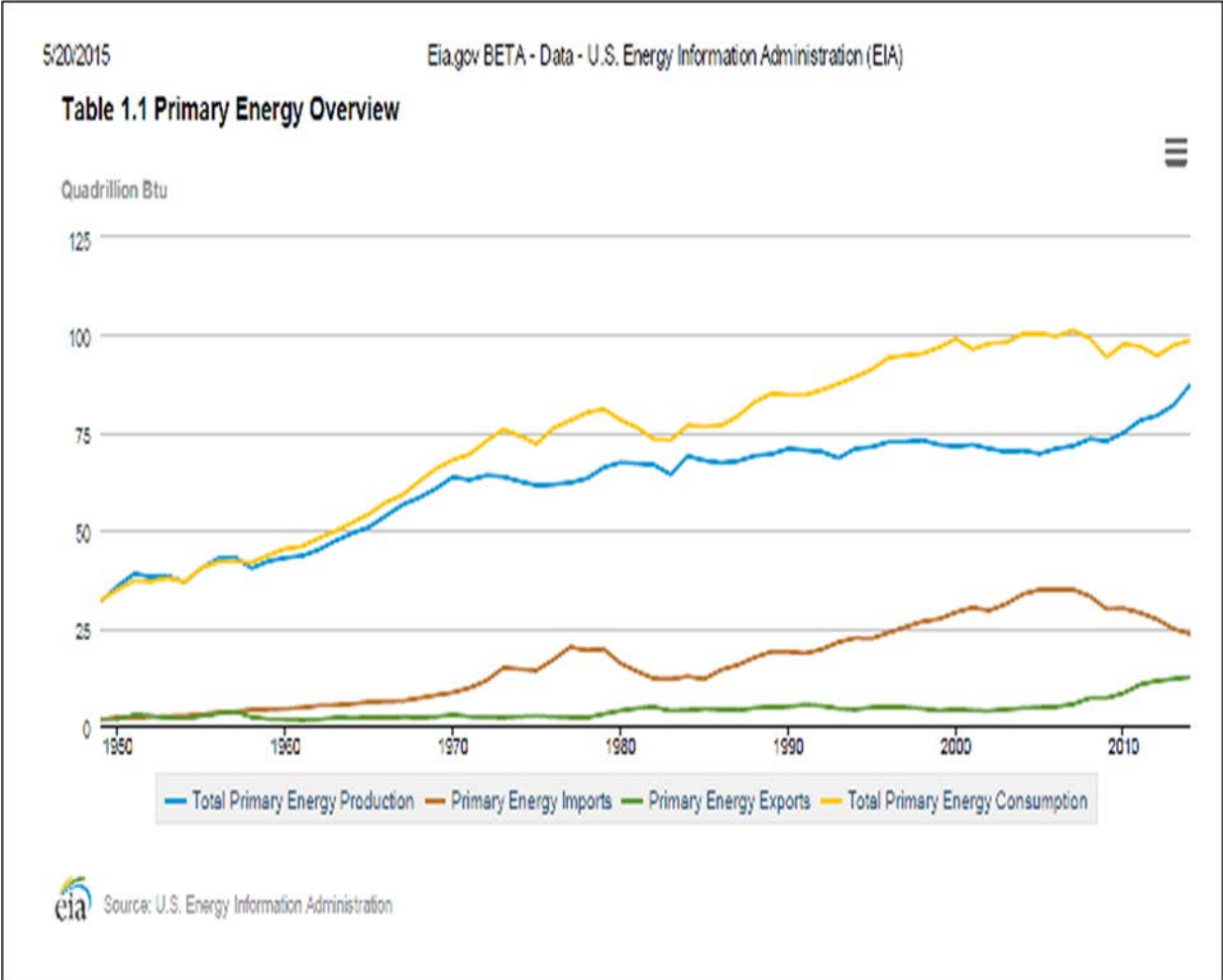

Figure 1 - History of U.S. total energy use

Figure 2 below illustrates a more complete timeline for the United States of the types of energy consumed [2]. In the early history of the US, wood was the leading source of energy, until overtaken by coal around 1890. Coal was then overtaken by petroleum just before 1950, and then by natural gas just after 1950. Since about 1940 however, petroleum has remained the top

energy source in the United States by a wide margin. It can also be observed that nuclear energy has been on the rise since the 1970's, while wood and hydroelectric sources have remained relatively constant since 1980.

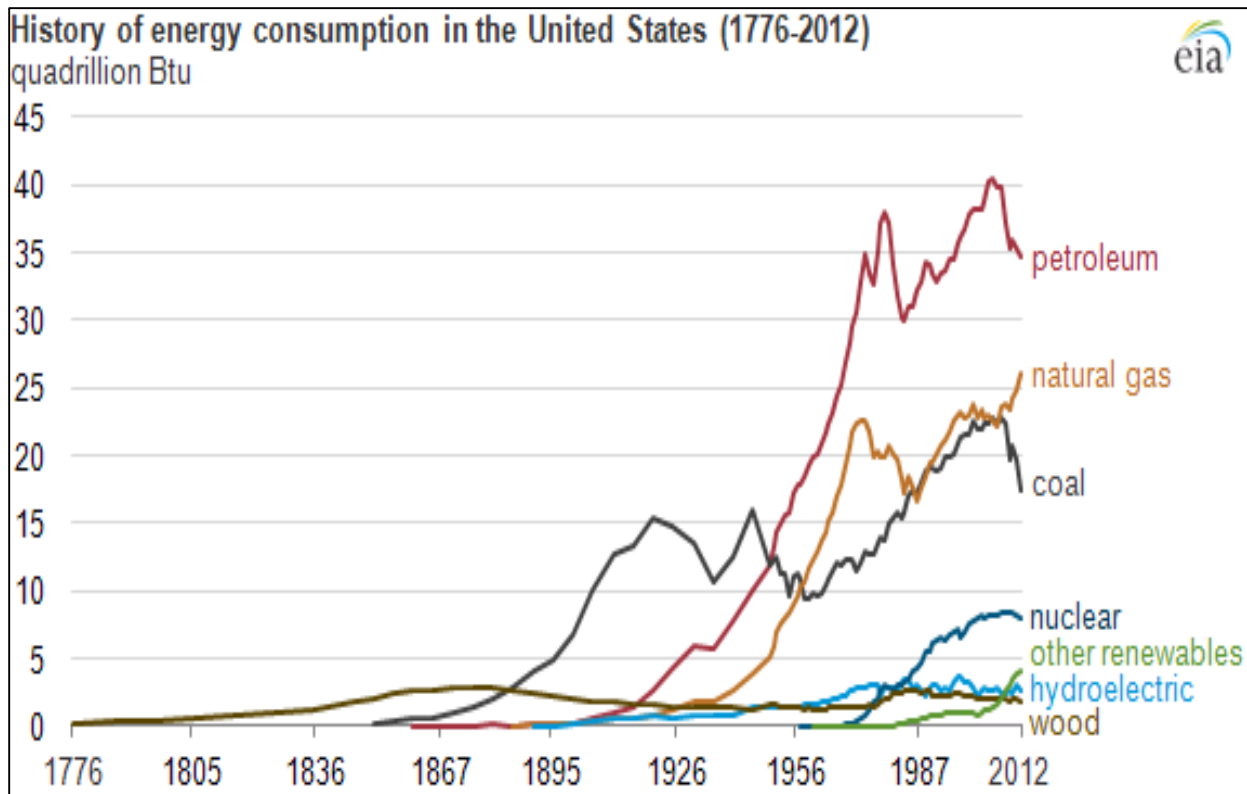

Figure 2 - Histogram of U.S. energy illustrating different energy sources

Regardless of the type of energy, all forms of energy have until recently exhibited an increasing trend, correlating with the overall increase in total energy consumption. Another notable trend however is that 'other renewables' have recently taken on a larger energy production role than hydroelectric and wood. It can be concluded that renewable energy production is growing due the various benefits over fossil fuels, such as minimal greenhouse gas emissions, and being sustainable [3].

Renewable energy in particular is depicted in Figure 3 below as a part of total energy consumption in the United States [4]. Renewables represent about ten percent of the total energy production, and includes hydroelectric, geothermal, solar, wind, and biomass. Notice in this figure that electric power generation/consumption accounts for about 40% of all energy produced. Also, notice that electrical power is generated from about 65% fossil fuel, and 13% renewable sources among others (primarily nuclear, hydro and wind). Although there has been a recent sharp increase in renewable energy production, the majority of electric power and overall energy consumption continues to be based on fossil fuel use as of 2014.

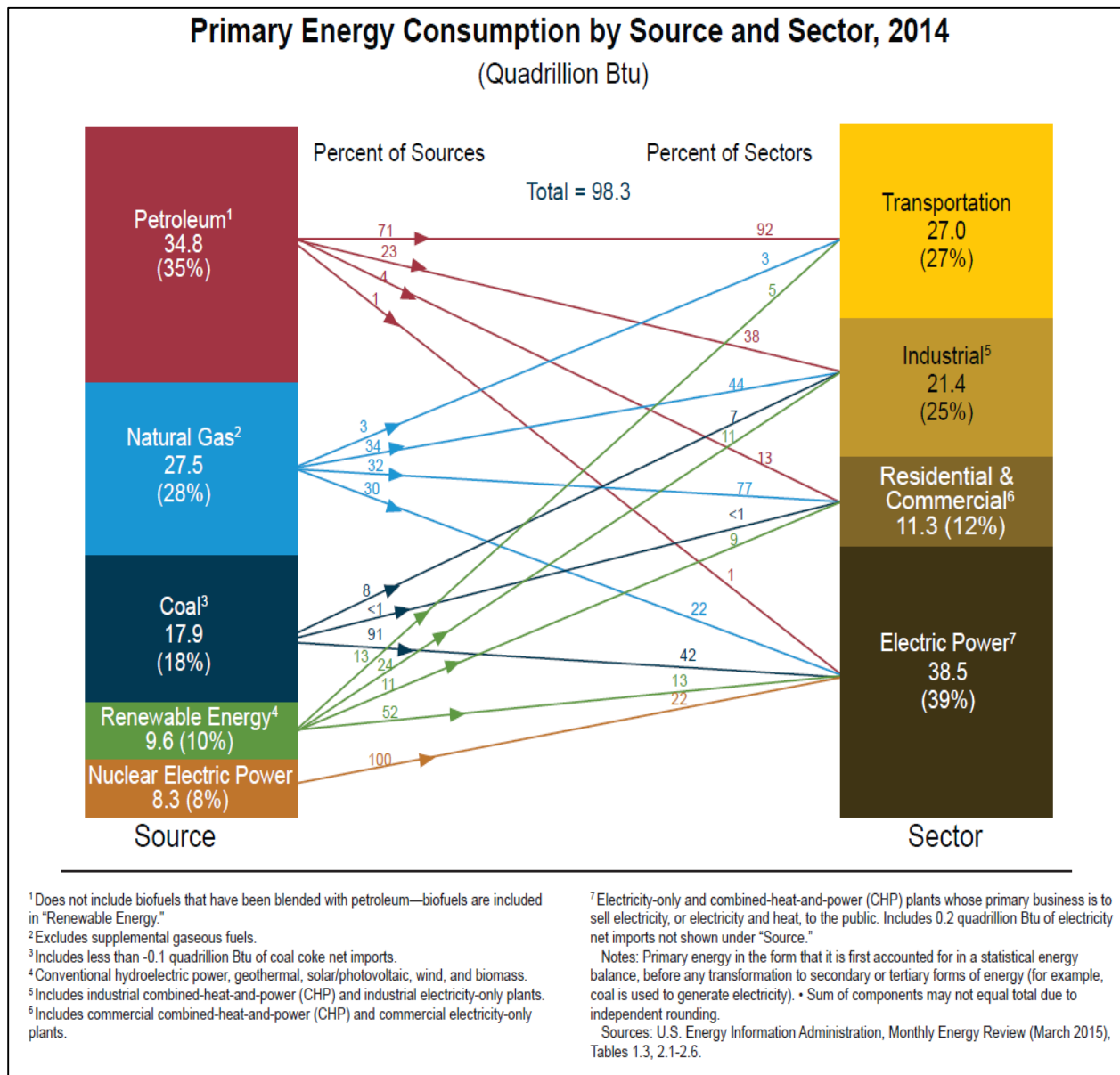

Figure 3 - U.S. energy consumption with an emphasis on renewable sources

US Electrical Energy Generation and Use

Figure 4 depicts how electricity is used in the United States [5]. This figure illustrates the consumption based on measurable electricity generation from utilities [5]. Electricity generation for 2014 was generated from power plants that used almost no petroleum; however, fossil fuels (primarily coal) still composed the majority of the electrical energy generation energy source. It is particularly interesting in this figure to note that about half of the electrical energy generated is lost to conversion losses. From Figure 4, there is an efficiency issue with the utility method and transferring that electrical energy to the consumer. Fuel-related energy requires a fuel cost, and the cost of this fuel may be considerably reduce if the Conversion Losses can be mitigated.

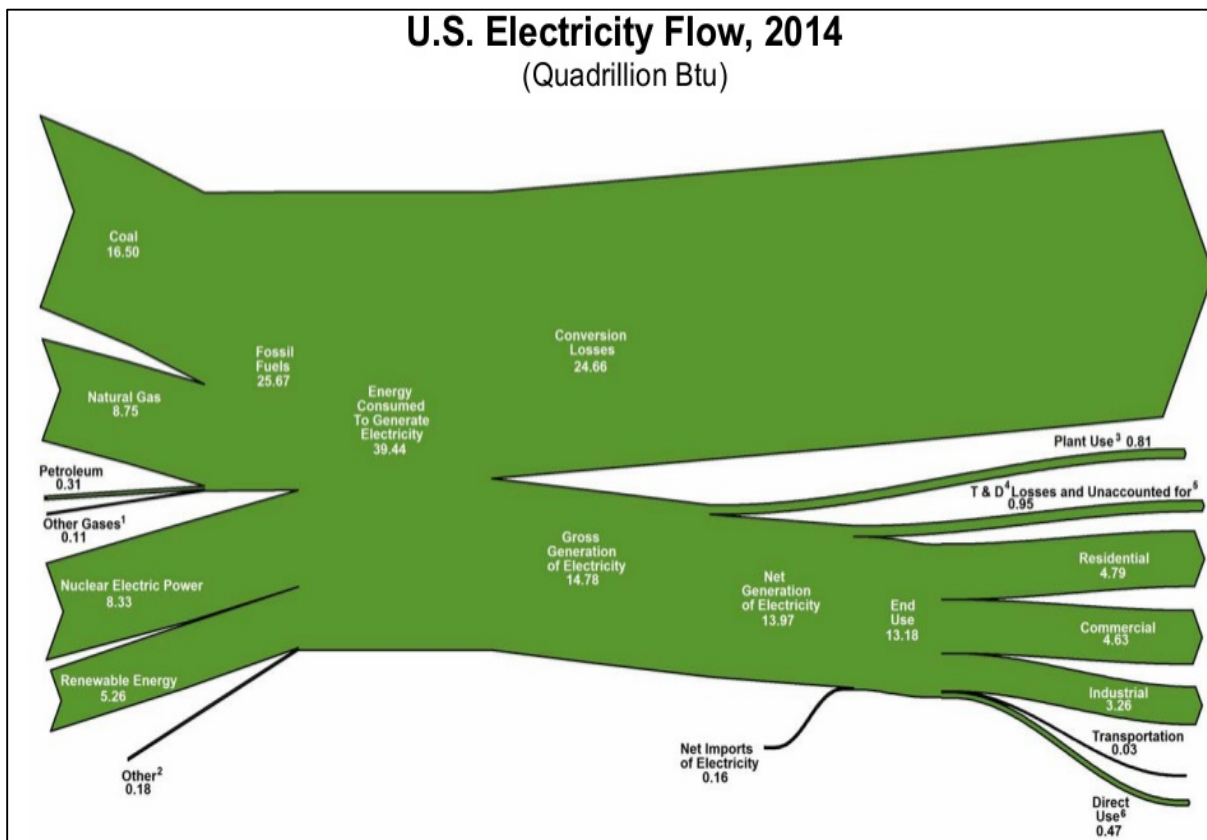

Figure 4 - Electric consumption flow in the U.S., source to target

Finally, renewable energy accounted for about 13% of the electrical energy generated in 2014. Since there is a continuing concern about the future availability of non-renewable energy sources for electrical energy generation, it may be possible to significantly reduce, or even eliminate the use of the fossil fuels as an electrical energy generation source if conversion losses could be significantly reduced. The reality is that conversion losses are a part of modern power plant energy generation, and additional losses are present in the required transmission lines to transport electrical energy to consumers. Using localized renewable energy generation, such as a home solar installation on every roof, would greatly reduce conversion losses and fossil fuel generation. Nevertheless, hypothetically omitting conversion losses illustrates the potential impact of efficiency improvements on modern electrical utility systems.

Sustainability and Photovoltaics

The increase in electrical energy demand can be met only by increasing electrical production. If the goal is to balance power needs in a responsible and sustainable way, then renewable energy sources should be used to generate electricity with minimal impacts on the environment.

A working definition of ‘sustainability’ can be taken directly from [6],

“...capable of being maintained in existence without interruption or diminution...”

Based on this definition, energy must both be self-sufficient and without negative impact to the surroundings, implying renewable sources. Renewable energy sources that seem to meet this definition of self-sufficient and no negative impacts include wood, hydroelectric, biomass, wind, photovoltaic and geothermal. The focus for this project was photovoltaic (PV) electrical energy generation.

As shown in Figure 5 below, PV cells are composed of semiconductor material, and convert solar energy directly to electrical energy [7]. Using PV collectors, electricity is generated by harvesting light from the sun and turning light energy into a useable utility [7]. PV collectors' dependence on sunlight alone and a lack of negative environmental impact fits well within the idea of sustainability.

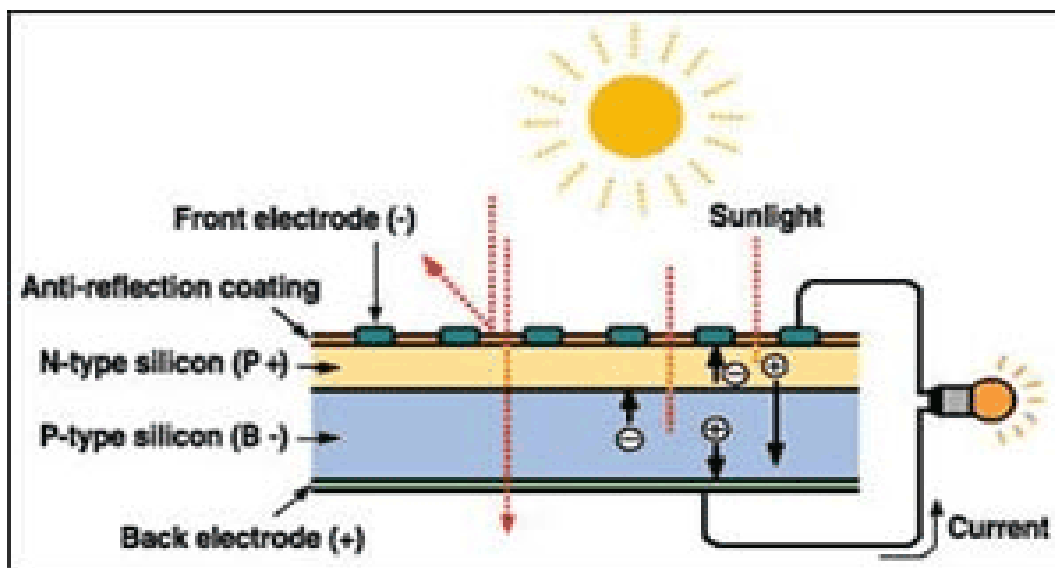

Figure 5 - Basic photovoltaic cell operation

Scouting and Sustainability

The Boy Scouts of America (BSA) have been helping the youth of America and abroad become 'self-sufficient and ethical leaders through the development of life skills' [8]. As stated in the BSA handbook [9],

“The mission of the Boy Scouts of America is to prepare young people to make ethical and moral choices over their lifetimes by instilling in them the values of the Scout Oath and Scout Law.”

There are multiple development activities available to scouting youth, nearly all of which have roots in outdoor stewardship and many of which are based on understanding the meaning and practice of sustainability. This basis in understanding and practice is embodied in the Boy Scout Outdoor Code, which explains these values as follows [9],

*“As an American, I will do my best to
 Be clean in my outdoor manners,
 Be careful with fire,
 Be considerate in the outdoors,
 and
 Be conservation minded.”*

The Project Site

Figure 6 is a map of the east side of the [Treasure Valley Scout Reservation \(TVSR\)](#), in the Mohegan Council in Massachusetts. Summer camp at TVSR facilitates an educational, hands on experience appropriate for scouts younger than 18 years of age [10]. The skills practiced during this weekly residential camp largely take part in the outdoors, where scouts can grow a further appreciation for nature [10].



Figure 6 - TVSR East Camp with reference to ECon

TVSR Environmental Conservation Building (ECon)

The TVSR ECon building is emphasized with an orange arrow and circle in Figure 6 above. An overhead depiction of the ECon building area was hand-drawn in Figure 7 [11]. There are a few things to note in Figure 7, including bathrooms in the lower left corner, old power lines connecting to the ECon building in the top of the figure, a campfire area, and even a beekeepers box in the figure's top center. Within the ECon building are lights, tables, and animal holding tanks for ecology education. It may be concluded from Figure 6 and 7 that the ECon site is relatively remote, has electrical energy needs, and would be a good candidate for a remote-site sustainable energy installation (such as solar generation) to meet electrical energy needs. The PV panels and self-sustained electrical system could then be used to further develop ecology conservation, and sustainability-education in scouting.



Figure 7 - ECon building

The ECon building consist of one large and one small room. The front room is used for most of the activities, whereas the backroom is used for storage. The large front room has one door on the south side of the building which is also the main entrance to the building. The backroom has one door which is accessed through the front main room. The electric lines arrives to this building through the north wall of the backroom. There is a 50A breaker placed inside a small metal box on the outside of the building. There are also two 20A breakers on the inside on the opposite side of the wall where the 50A breaker is installed. All electrical wires are distributed from these two 20A breakers into the backroom and the large main room.

1.1 Project Statement

The goals for this project were to:

1. Assess the electrical energy needs of the Environmental Conservation (ECon) building,
2. Develop a plan using solar energy to meet the ECon building needs,
3. Develop a plan for sustainability studies and solar energy generation to be incorporated into existing scouting educational programs and badges, and
4. Develop a vision for the future use of the ECon site as a center for Science, Technology, Engineering, Math (STEM) and sustainability studies.

Within the context of providing for the ECon building energy needs, our outcomes included assessing the electrical energy needs of the building, and designing a PV system which would meet the buildings electrical needs.

Relative to our third goal, our outcomes included educational benefit for the Scouts through observing and learning from the ECon building. This outcome had an emphasis on highlighting various methods of scouting achievement and advancement, such as merit badges, other sustainability related awards, and NOVA program awards.

Relative to the fourth goal, the work done on the ECon site by this project modified the ECon building and the way the ECon site is used for education. By planning for future development of the ECon site to further STEM and sustainability education, the ECon site could serve as a valuable resource and model for the BSA and their STEM related programs. The vision for the ECon site will provide a direction to continue progress after the completion of this project.

Finally, it is worth mentioning that there have been previous projects at TVSR that investigated PV panel potential for the purposes of lighting for a few hours at night. This project has differed from the previous projects by providing electrical energy for a small building in its entirety, and educational material distributed for the Scouts' benefit. Additionally, this project was a larger scale project than those previously conducted at TVSR, and could serve as an example to other larger projects around the camp.

1.2 Summary

This project addressed the sustainable electrical energy needs of the TVSR Econ building and the need for a sustainable energy plan for TVSR. The need was assessed and a plan was developed to build a PV panel system which would supply the energy needs of the Econ building. The knowledge gained from planning and implementing a PV system for the Econ building allowed for informative material to be created for the scouts, focused on sustainability education and advancement. The future use of the ECon site was then envisioned through providing suggested development of the site to further the STEM and sustainability education at TVSR.

2.0 Background

In this section, descriptions for topics relevant to this project will be provided such as Boy Scout advancement, solar photovoltaic systems, educational theory, solar financial planning, and solar site planning.

2.1 Electrical Background

There are number of electrical terms which will be repeatedly used in this project. This section will provide brief descriptions for each of the electrical terms which are associated with solar energy generation and storage systems. In additions, the formulas to obtain critical solar energy values will be explained.

Volt

The Volt (V) is a potential difference of electrical forces between two conductors [12]. Figure 8 below is a painting of the Italian physicist Alessandro Giuseppe Antonio Anastasio Volta (1745-1827). The electrical term name Volt is to honor Alessandro Volta for inventing the voltaic pile and the chemical battery.



Figure 8 - Alessandro Giuseppe Antonio Anastasio Volta (1745-1827) [13]

Typical voltage at our homes in the US is 120V alternating current (AC). Most home appliances and electronics are designed to operate at 120VAC for this reason. Boats, automobiles, recreation vehicles (RV) and campers use 12V direct current (DC) batteries to supply electric to their electronics. The electronics which are designed to be used in boats, automobiles, RVs and campers are designed to operate at 12VDC.

Ampere

The Ampere (A), often shortened to “amp” is the amount of electric charge per volume flowing through a conductor [12]. Figure 9 below is a painting of the French mathematician and physicist André-Marie Ampère (1775–1836) who the unit is named after, and honors André-Marie Ampère who is considered the father of electrodynamics.



Figure 9 - André-Marie Ampère (1775-1836) [14]

In many electronics such as batteries, fuses, and breakers, Amperes are used to represent their capacity. These electronics are designed to operate on a single specific voltage, however if different voltage potentials are used, the Amperes differs due to the Ohm's law. For instance, a 60W compact florescent light (CFL) uses one half an AH at 120V; however, a 60W CFL designed for 12V uses 10AH. On a system with multiple voltages, it is more appropriate to use Watts to represent capacity.

Watts

The Watt (W) is work performed in electrical terms [12]. It is the associated term which represents instantaneous electrical power. The Watt is calculated using Equation 1 below where "V" is the voltage across the system and "I" is the current flow. In Equation 1, substituting I times R for V from the Ohm's Law results Equation 2 below to calculate the power. In this form the power equation is independent from the voltage. Due to these characteristics, the Watts are preferred in terms of representing power.

$$P(W) = V \times I(A)$$

Equation 1: Watt Equation.

$$P(W) = I^2R$$

Equation 2: Watt Equation with V substituted

Figure 10 below is a painting of the Scottish inventor and mechanical engineer James Watt (1736-1819). The electrical term name Watt is to honor James Watt who invented the concept of horsepower and its electrical equivalent, the watt.

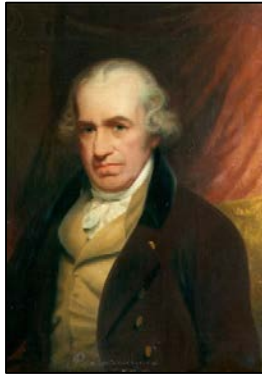

Figure 10 - James Watt (1736-1819) [15].

Resistance

Electrical resistance is the restraining force electricity must overcome to flow through the conductor [12]. Electrical resistance is measured in Ohms. The electrical term “Ohm” was named to honor the German physicist Georg Simon Ohm depicted in Figure 11 below. Materials with very low resistance to current flow (think of a large diameter water hose) are called conductors and materials with very high resistance to charge flow (think of a small diameter water hose) are called insulators. Copper (Cu) and aluminum (Al) are two of the commonly used conductors with high conductivity and low cost [16]. All electrical components have an inherited resistance associated to them.



Figure 11 - Georg Simon Ohm (1789-1854) [16]

Joules

The Joule (J) is the electrical term for energy and represents total power used over time. The electrical term “Joule” was named to honor the English physicist James Prescott Joule (1818-1889) pictured in figure 12 below.



Figure 12 - James Prescott Joule (1818-1889) [17]

The total energy in Joules used in a system can be calculated by multiplying the power consumption in Watts with the time in seconds the system is on. For instance, a 6 Watt LED uses 6 Joules of energy every second. Watts and Watt-Hours are preferred over Joules because the convention of electricity that uses Amperes and Volts creates simple equations with Watts, not Joules.

2.2 Solar Energy System Basics

There are number of components incorporated into solar electric energy generation and storage. Some setups are very complicated, needing many additional components than just solar panels. Figure 13 below represents a complex solar system setup with its associated components. Definitions for the components which are associated to solar systems are discussed in this section. Furthermore, different types of solar systems are also explained. This sub-section will serve as the technical background for this project.

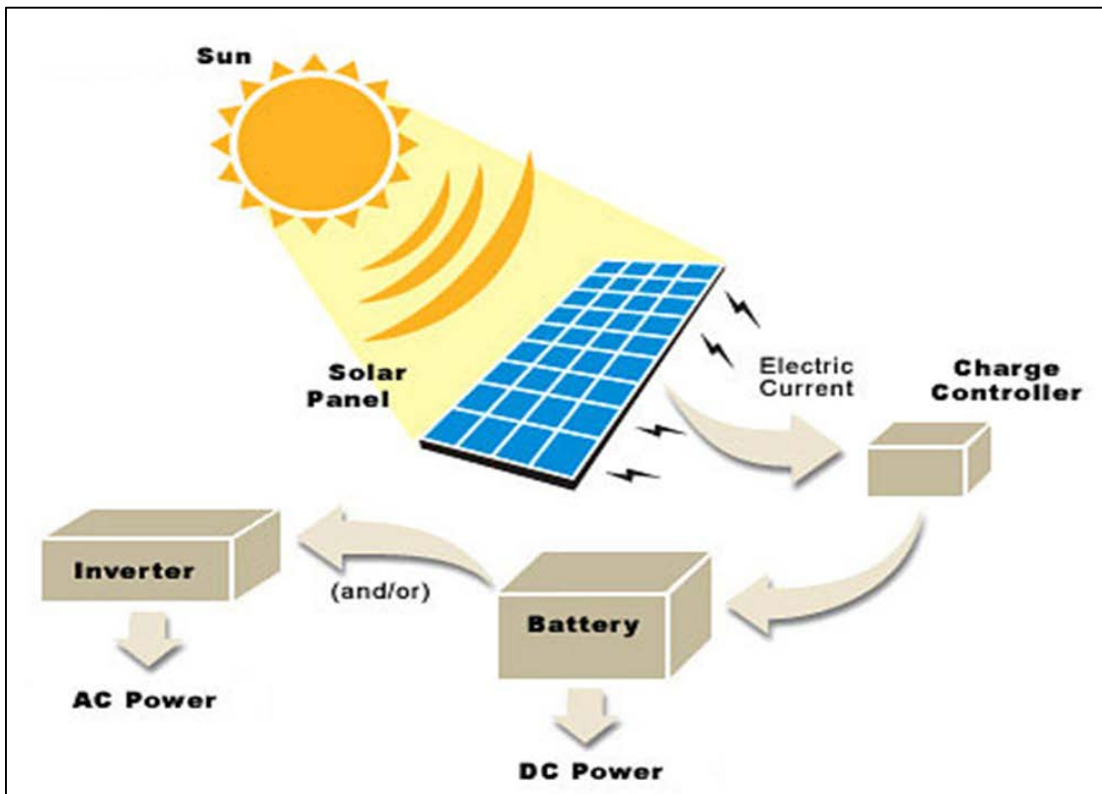

Figure 13 - A solar system with associated components [18]

Solar Panels

Thermal and Photovoltaic solar panels are the two primary solar panel types. Thermal solar panels use the thermal effect of solar energy to heat water directly and can only work during the day when sun is available [16]. The thermal heating effect cannot be stored, and therefore cannot be taken advantage of at night. Figure 14 below has a close up picture of a thermal solar panel installation.



Figure 14 - A thermal solar panel installation [19].

Below figure 15 is a representation of one of the tubes in a thermal solar panel. The tubes in the thermal solar panel are made of glass and their inner surface is tinted black. Sunlight gets trapped

inside the evacuated-tube and converts to heat by the tinted dark inner surface. A copper pipe inside the tube absorbs the heat and the hot vapor raises to the elevated side of the panel while the cold vapor moves to the bottom to repeat the cycle [6].

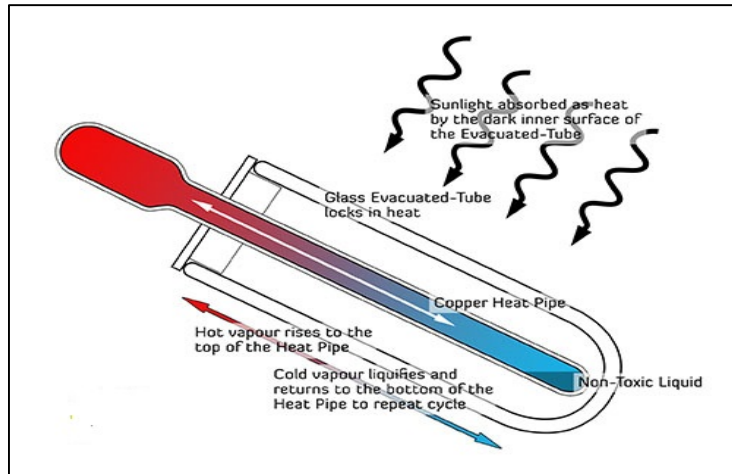

Figure 15 - Thermal Solar tubes in detail [20].

Photovoltaic (PV) solar panels are responsible for converting light energy into electrical energy using the photovoltaic effect, and much like thermal systems, only create electric energy when sunlight shines onto the panel's surface area [16]. Figure 16 below illustrates a PV cell in detail. The PV cell is made up of negatively charged n-type and positively charged p-type silicon conductors which are stacked horizontally in equal size to each other (very similar to a diode). Some of the energy gets absorbed when the sunlight shines on the PV panel and this energy frees electrons in the n-type silicon which allow them to flow through the p-type silicon. This flow creates the electric current in the panel [6].

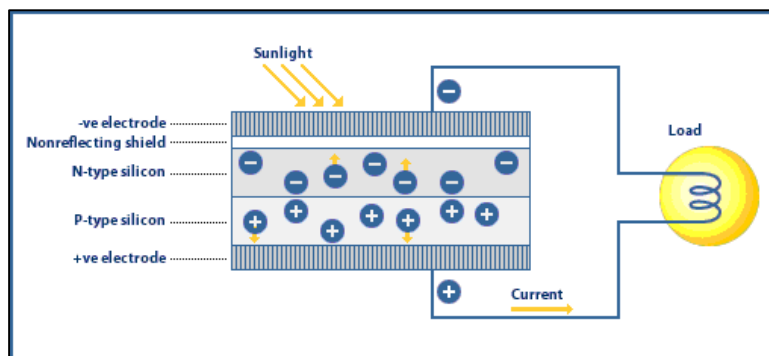

Figure 16 - PV cell in detail [21].

Figure 17 below depicts a picture of multiple PV panels mounted on the ground. Some of these panels are connected in parallel while some are in series. Series connected panels allows the total voltage output to reach to a desired system design voltage level and while parallel connected panels increase the total current at a given voltage. In many applications, multiple stacks of

series connected panels are also parallel connected to other stacks of series connected panels to optimize the efficiency of the solar system based on specific design goals.



Figure 17 - Multiple PV panels mounted on the ground [22]

Solar Panel Mounting

Mounting and positioning the solar panels correctly is critical to collecting as much sunlight as possible, maximizing electrical energy. A PV system operates at maximum efficiency when the panels are mounted at a location and position which allow them to get direct sunlight throughout the day. There are multiple mounting options. The most common are roof mounted, ground mounted and wall mounted.



Figure 18 - PV panel roof-mounted on a hard shelter roof at TVSR

In locations where a ground location isn't available or stable, roof mounting makes good use of roof space as seen in Figure 18. The roof must be able to handle the additional weight of the

panels and the angle of the roof may need to be modified to point the panels in the direction that receives direct sunlight. Although PV panels are maintenance free, debris on panels such as snow, branches and leaves must be periodically cleared to further generate as much energy as possible.

Accessing the roof to clean roof-mounted panels from debris or adjust for different season angles can be difficult. Wall mounting, shown in Figure 19 below, is favored over ground or roof mounting where a stable ground location is not available and can also provide easy access to panels.

Ground mounting the panel as in Figure 17 above is favored where there is plenty of stable ground space available. In this configuration, the panels can be easily cleared from any debris and adjusted for the optimum angle for the months or seasons of the year. For properly mounting panels on the ground, the ground must be suitable to support the panels, and a trench for an underground transmission line might be necessary to safely transfer the power to the desired site.



Figure 19 - PV panel wall mounted [23]

Solar Panel Pointing

The positioning of the solar panel is an important step in gathering as much light energy from the sun as possible. The path of the sun in each month is different as shown in the figure 20 below. If the solar panel is pointed to one fixed angle, it will only have sun beams perpendicular to it in only one month. Adjusting the panel mounting angle according to seasons or months can increase efficiency of the PV panel.

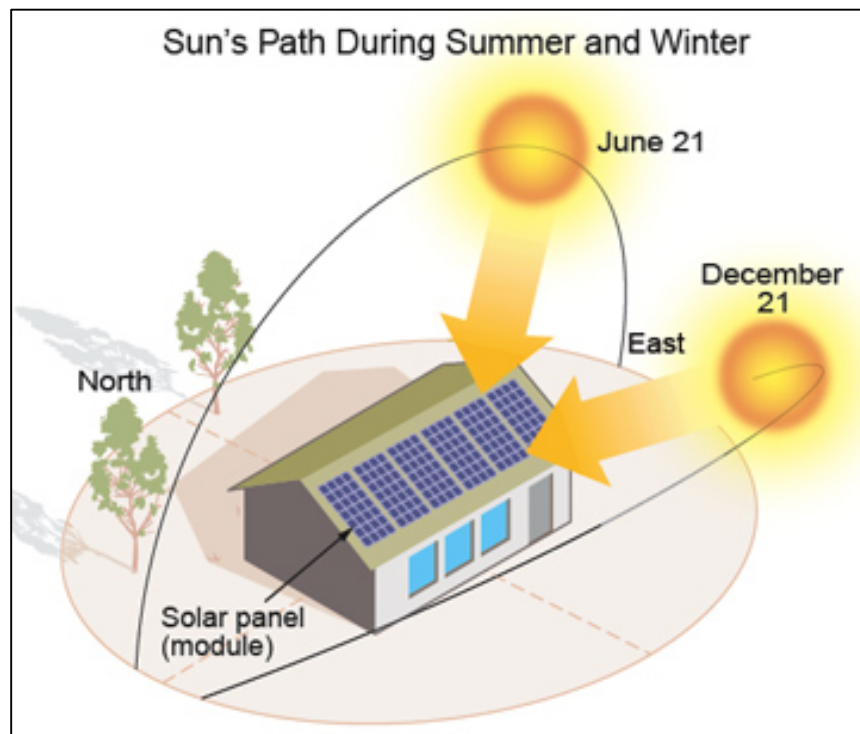

Figure 20 - Solar panel mounting angle considerations [24].

For solar panel locations in the northern hemisphere, the angle of panels should be equal to the latitude of the location and also adjusted according to magnetic declination. Magnetic declination must be adjusted because accuracy in tracking the sun depends on the direction of true north, whereas the compass points to magnetic north. Applying a minus tilt angle of 15 degrees to this angle in the summer and a plus 15 degrees in the winter can further improve efficiency [16]. For example, in Worcester (42 degrees north latitude) the optimal panel angle in the summer is about 35 degrees from horizontal, while in the winter it is about 55 degrees from horizontal.

Charge Controller

A charge controller is an electrical device responsible for controlling the charge to the PV system batteries, and for regulating the charge taken out of the batteries to the power system loads. During solar electric generation, charge controllers direct the PV generated energy (current) into batteries as well as to the loads. When the batteries reach to maximum charge capacity, the charge controller limits the current flow to the batteries to a trickle charge level to maintain the batteries in a state of full charge [12].

Charge controllers use various techniques to adjust charging current flow to ensure maximum lifespan is achieved from batteries, depending on battery chemistry (lead acid, NiMH, Lithium, etc.). Charge controllers also limit the power provided to loads when the battery voltage indicates that the battery energy capacity has been depleted. As a result, charge controllers extend the life

of the batteries and increase the efficiency of solar systems by insuring that the system batteries are not overcharged or fully depleted.

Storage

Since solar cells generate power only during the day, the electricity must be stored in order to provide power at night. As noted in the previous section, batteries are used to store charge [16]. The most common type of batteries are deep-cycle sealed lead-acid batteries. These batteries can discharge to 20 percent capacity without any damage occurring to them.

When connecting multiple batteries in series, the total voltage is calculated by adding all battery voltages together. In a series configuration, the total voltage output of the combined batteries is increased where as their *individual* battery energy capacity (in AH) remains unchanged. However, the *system* energy capacity is doubled since the voltage is double with two identical batteries in series (WH). When connecting batteries in parallel, the voltage of the batteries must be identical. As a result, the system voltage is the same as a single battery, and the system current is the sum of the individual batteries' energy capacity (in AH) [16].

Inverter

Most electrical appliances and lights utilize 120VAC in residential and industrial environments. Since electricity is generated as direct current (DC) through solar panels, an electrical device called inverter is needed to make the necessary conversion [12]. Fortunately many common electronic devices are offered in DC versions for motorhomes and boats. As a result, many of the electronics found in residential environments can be replaced by their DC version equivalents and therefore need no power conversion system: however, appliances that are not available in 12V or 24V DC versions would require an inverter to supply the 120VAC necessary from a DC source.



Figure 21 - Pure Sine Inverter.

Modern inverters use high speed switches to alternate the polarity of the DC current provided hence creating AC current. Pure sine wave filters furthermore add complex circuits and filtering to create sine waves as opposed to the square wave outputs of less expensive inverters. Figure 21 above is a picture of a Pure Sine Inverter by Wagan which has an output power capacity of 400W.

Solar Path Finder

[The Solar Path Finder](#) (SPF) is a device used to analyze a site for optimum sun exposure, allowing efficient placement of the solar panels. Figure 22 below is a picture of the SPF device set up and in use. The SPF device is a round object with a diameter of approximately 8 inches with a level in the center for best alignment and a compass for aligning the solar pathfinder with magnetic north. The manufacturer provides multiple survey charts which have associated lines for the appropriate latitude. These lines represents the path of sun at various months of the year and various times of the day. Charts for different latitudes can also be ordered, in case the SPF is to be used in different parts of the globe.



Figure 22 - Solar Path Finder.

A tinted glass dome is placed at the top of one of these charts. The dome focuses the sun rays onto the chart under the dome. Any obstacles blocking the sun appears as shadows on the chart. These shadow areas then represent the months of the year and hours of the day when solar power generation will be interrupted by these obstacles.



Figure 23 - A SPF survey on a chart.

To use the SPF, a specific site for placement must be found. Then, a chart must be selected by matching an appropriate latitude range to the survey location. Figure 23 above shows a chart with a specified range between 37 and 43 degrees latitude. The SPF is also equipped with an air-bubble level and a compass. Once assembled, the SPF can be adjusted at the base to configure the level and compass. The compass and the level inside the SPF are used to collect the most accurate data possible, by flattening the SPF with the level for proper sun angle and aligning the SPF with the compass to a specific magnetic north declination. Once the SPF is configured correctly, the direct sunlight potential and shading can be seen through the tinted glass dome, and the chart can be marked by hand to use later for a closer analysis.

2.3 PV Panel Environmental Concerns

PV panels are made up of silicon PV cells, and the environmental pollution from producing silicon cells is not considered significant [16]; however, in the process of manufacturing PV panels, some toxic chemicals are used. Since the panels are solid glass encased, and the cells themselves bind the toxic chemicals in a glass like substance, solar cells are not considered environmentally hazardous. Further, when generating electricity, solar energy replaces fossil fuels and nuclear fuels, which have well-known negative environmental impacts and problems.

2.4 Types of Solar Installations

There are multiple solar systems available today. Among the most typical are grid tied systems and off grid systems. A backup generator can be incorporated in any one of these in order to sustain system operation continuity during limited sun times (clouds, night) or loss of battery power.

Grid-Tied

The most common type of residential solar installation is a grid-tied system. Grid-connected or grid-tied systems are directly tied to the electric utility. The energy generated supplies your building first, and the surplus is put directly into the utility grid through the utility meter. By putting energy into the grid through the meter, the owner of the installation may run the meter backward, effectively lowering the monthly electric bill. A grid-tied installation can only supply energy directly during the day due to no energy storage setup, therefore using the electrical utility for energy needs at night. Grid-Tied solar installations are most common because the consumer is allowed to rely on the utility for high energy use when needed, and the cost is considerably lower without an energy storage system.

Off-Grid

This type of PV energy generation is popular in remote locations where electric utility is either unavailable or too expensive. In off-grid systems, electrical energy is provided solely through solar energy generation. Most off-grid systems employ the use of battery energy storage, so electrical energy may be used at night. The primary concern with an off-grid installation is the limiting energy provided by current PV panel technology, and the limiting energy capacity of the current battery technology.

Hybrid off-grid systems incorporate a backup generator in case peaks loads need more power than the system batteries can safely provide, or if the batteries are not sufficiently charged by the PV panels because of clouds, rain, or other issues. Grid tied systems can also benefit from being a hybrid system during power shortages.

2.5 Solar Power Financial Incentives

Building a solar installation costs money, and financing options for renewable sources vary from state to state. TVSR is under the umbrella of the Mohegan Council, and is considered a non-profit organization, which is given a 501(c)(3) tax code by the United States Internal Revenue Service (IRS) [25]. A non-profit organization must meet certain [requirements](#) to be exempt from taxation by the federal government, and can be described as benefiting charity instead of individuals or private stakeholders [25]. Non-profit tax code also declares corporation status, and includes special tax-exempt circumstances the Mohegan Council may benefit from [25].

National Incentives

As far as the federal government is concerned, non-profit organizations do not benefit from solar installation tax credits due to their tax exempt status [26]. As a result, tax exempt organizations are often challenged to find funding for solar projects [26]. In particular, lenders are reluctant to support small solar (and other) projects due to higher risk, including the bad publicity connected to the possibility of foreclosing on a non-profit whose cause is charity.

There are, however, certain federal agencies that support sustainability projects and collect grant information for non-profit organizations. The Environmental Protection Agency (EPA) provides a list of funding opportunities for ‘Green Building’ [27]. One of these opportunities specifically for Massachusetts is the [Renewable Energy Trust Fund](#), both for non-profit organizations and for PV installations [27].

Massachusetts State Incentives

[The Solar Carve-Out II Program](#) is the latest solar incentive program, and was developed to expand PV installations in the state of Massachusetts including non-profit organizations [28]. This program has several goals, one of which is to grow solar installation to reach 1,600 MW by 2020 [28]. One important caveat of this program is that the power generated must be connected to the utility grid in Massachusetts [28], thus eliminating the possibility of any non-grid tied system from receiving program funds.

The Solar Carve-Out Program is market production based, where rebates in the form of Solar Renewable Energy Certificates (SRECs) are earned for each megawatt produced [28]. The Table 1 below describes the SREC earnings categories.

Table 1 - SREC Earning Categories for Solar Carve-Out II Program

Market Sector	Generation Unit Type	SREC Factor
A	<ol style="list-style-type: none"> 1. Generation Units with a capacity of <=25 kW DC 2. Solar Canopy Generation Units 3. Emergency Power Generation Units 4. Community Shared Solar Generation Units 5. Low or Moderate Income Housing Generation Units 	1.0
B	<ol style="list-style-type: none"> 1. Building Mounted Generation Units 2. Ground mounted Generation Units with a capacity > 25 kW DC with 67% or more of the electric output on an annual basis used by an on-site load 	0.9
C	<ol style="list-style-type: none"> 1. Generation Units sited on Eligible Landfills 2. Generation Units sited on Brownfields 3. Ground mounted Generation Units with a capacity of <= 650 kW with less than 67% of the electrical output on an annual basis used by an on-site load. 	0.8
Managed Growth	Unit that does not meet the criteria of Market Sector A, B, or C.	0.7

Other Financing Options

There are a few options outside government aid specifically designed for non-profit organizations. Three options currently exist:

- 1.) Solar Power Purchase Agreements (PPA) are very similar to a solar lease with little to no upfront cost of the installation; however, the PV system is owned by someone else. The PPA is designed for the user to be able to buy electricity at a lower price than the utility company provides, includes equipment maintenance, and typically is contracted for about 20 years [29].
- 2.) Property Assessed Clean Energy (PACE) allows for the price of the solar installation to be paid over 20 years in property tax ‘through a special tax assessment’. Although non-profits do not pay property tax, the special tax assessment is allowed, and can be used in conjunction with other incentives, including PPA [29].
- 3.) Crowd Funding is done through a finance company that collects investors, pays for the solar installation, and collects from the non-profit as a PPA would. This allows the non-profit a lower electricity bill, and a return for the investors [29].

2.6 Scouting Advancement

The BSA has clearly and thoroughly defined advancement for Scouts. There are three main sections in [Advancement Defined](#) [30]:

- 1.) It is a Method – Not an End in Itself
- 2.) Advancement Is Based on Experiential Learning
- 3.) Personal Growth Is the Primary Goal

These three guidelines are set in place primarily to ‘further the BSA mission’ and ‘broaden horizons at the individual Scouts’ level’ [30]. Through these definition branches, a method is implemented to fulfill the scouting mission in Cub Scouting, Boy Scouting and Varsity Scouting, Venturing, and Sea Scouts [30].

Scout Rank

Boy Scout rank is a fundamental system of scouting advancement particular to the individual Scout. There are seven ranks each scout can achieve, starting with Scout and ending at Eagle [31]. The badges for each of the scout ranks is shown in Figure 24.



Figure 24 - Scout rank badges [32]

To correspond with the goal of scout education, it is important to note that the age requirement for earning scout advancement must be within a certain age range. The age range is before the Scouts’ eighteenth birthday, and in meeting one of these rules [31]:

- 1.) Be 11 years old,
- 2.) Has completed the fifth grade,
- 3.) Has earned the Arrow of Light Award and is at least 10 years old

It may be concluded that the age range is early adolescent to the beginning of adulthood, from the ages of 10 to 18.

Merit Badges

The merit badge system is designed for Boy Scouts to acquire skills by completing requirements in specific modules. A merit badge is earned by completing specified activities in any order, after which an iconic patch is presented to the Scout in a ceremonious fashion. Figure 25 below displays a typical merit badge and a partial example of a requirements list [33].



Figure 25 - The Engineering Merit Badge

Requirements

1. *Select a manufactured item in your home (such as a toy or an appliance) and, under adult supervision and with the approval of your counselor, investigate how and why it works as it does. Find out what sort of engineering activities were needed to create it. Discuss with your counselor what you learned and how you got the information.*
2. *Select an engineering achievement that has had a major impact on society. Using resources such as the Internet (with your parent's permission), books, and magazines, find out about the engineers who made this engineering feat possible, the special obstacles they had to overcome, and how this achievement has influenced the world today. Tell your counselor what you learned.*
3. *Explain the work of six types of engineers. Pick two of the six and explain how their work is related.*
4. *Visit with an engineer (who may be your counselor or parent) and do the following:*
 - a. *Discuss the work this engineer does and the tools the engineer uses.*
 - b. *Discuss with the engineer a current project and the engineer's particular role in it.*
 - c. *Find out how the engineer's work is done and how results are achieved.*
 - d. *Ask to see the reports that the engineer writes concerning the project.*
 - e. *Discuss with your counselor what you learned about engineering from this visit.*

Each merit badge must be achieved by working with an approved merit badge counselor, who has advanced knowledge in the specific merit badge and ultimately decides upon examination of the scout whether the scout has achieved both the spirit and requirements of the desired badge [31]. The description is best summed up as [31],

“You can learn about sports, crafts, science, trades, business, and future careers as you earn merit badges. There are more than 100 merit badges, and any Boy Scout or Varsity Scout, or any qualified Venturer or Sea Scout may earn any of these at any time.”

There are multiple merit badges that have one or more requirements pertaining to sustainability and solar energy. Requirement 6e for the Engineering merit badge in Figure 25 is an example of how solar energy education and project work can be done to help earn the merit badge, and lists as follows [33],

“Converting energy. Do an experiment to show how mechanical, heat, chemical, solar, and/or electrical energy may be converted from one or more types of energy to another. Explain your results. Describe to your counselor what energy is and how energy is converted and used in your surroundings.”

Certain merit badges are required to reach the rank of Star, Life, and Eagle [31]. Each of the merit badges below in Figure 26 have at least one requirement pertaining to sustainability or solar energy [31]. Additionally, a merit badge with a silver colored ring around the outside is required for Eagle rank, while the merit badges with a green colored ring around the outside are not required for Eagle rank [31]. A scout must earn a total of twenty-one merit badges to achieve Eagle rank, of which thirteen are essentially required, such as the Sustainability merit badge in Figure 26 [31].

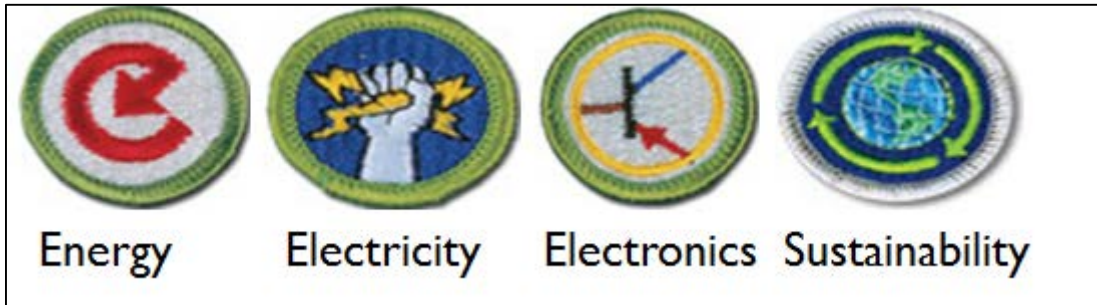

Figure 26 - Merit badge sampling

Certain merit badges are also required to achieve [Eagle Palms](#) and the Hornaday Awards, depicted in Figures 27 and 28 below [34] [35]. Eagle Palms may be awarded if a scout has earned Eagle rank and is under the age of eighteen, while earning additional merit badges not already used to earn Eagle rank [31].



Figure 27 – William T. Hornaday Medal



Figure 28 - Eagle Palms

Eagle Palms may be awarded by earning any merit badge, but the William T. Hornaday Awards require specific merit badges [34]. Hornaday awards are based on project work, and include the earning of certain merit badges in conservation and ecology [34]. The Hornaday Awards are not required to attain scout rank; however, the achievement of a Hornaday medal is difficult and prestigious, as only around 1,100 have been awarded since the medals' inception date of 1917 [34].

“Dr. William T. Hornaday, an ardent conservationist, established this awards program to recognize Scouts who undertook and completed truly exceptional conservation projects. Earning one is hard work—it is supposed to be—but it's worth it [34].”

Nova Awards

The Nova Awards depicted in Figure 29 below, were developed to take advantage of the learning opportunities that modern STEM programs have to offer [36]. The Nova program helps scouts develop relevant modern skills in order to be prepared in their present and the future lives. The Nova Awards stand out in scouting due to their recent creation, appeal to STEM activities unrelated to typical outdoors activities, and requirements coinciding with sustainability and solar energy.



Figure 29 - Nova Award patch

There are a few other aspects of the Nova Awards that distinguish them from the rest of the scouting awards, such as their appeal to all age ranges in scouting, unlike merit badges. Nova awards requirements are also different for each of the four categories: Cub Scouts, Webelos, Boy Scouts, and Venture Scouts [36]. Another difference from other scouting awards is that they are not required to gain rank, and at present seem to be unrelated to rank; however, some requirements for the Nova Awards include earning certain merit badges [36].

2.7 STEM and Education

This section talks about the role of STEM in the American job market, the vitality of STEM professionals, the availability of STEM careers, and the importance of STEM education, and some opinions surrounding STEM. Information regarding STEM and education is vital to understanding this projects' motivations in education and in how the future of the ECon site has been envisioned. STEM education has become a national priority for the Obama administration and is commonly described as the key to the prosperity of the future of the United States [38].

Beginning with the federal governments' perspective, President Barack Obama has stated [37],

“...Leadership tomorrow depends on how we educate our students today – especially in science, technology, engineering and math.”

The perspective also describes a deficit in engagement and interest in professional STEM fields, falling behind other counties in test score statistics and not meeting projected STEM job openings [37]. A second STEM focus is to train teachers to excel in STEM education and to engage and properly teach students STEM topics [37]

Further considering the national concern for enhanced STEM education, the growth in employment for STEM jobs from 2010 to 2020 is projected to be about 5% higher than the projected growth of all other employment [39]. Given these projections, the need for enhanced STEM education would clearly help provide leaders and workers with the expertise needed for growth of the US economy.

In contrast to the projections and focus of the federal government, others have contrary opinions regarding whether STEM should be a legitimate concern to the future of the US. The first argument against the federal stance is that the job projections are estimations, and cannot be considered accurate as they have been decidedly inaccurate in the past [40]. That is to say, assuming an 'above average' job market projection does not mean it will happen, and has failed to happen in the past.

Another criticism of a national STEM initiative is that the numbers of projected jobs are not sufficient to support the number of students that graduate with a STEM focus [40]. Also, it has been reported that many with STEM credentials work in non-STEM related fields, and that after 10 years of earning a STEM degree, 58 percent of the graduates had chosen to work in another line of work [40]. In addition to people leaving the STEM field, STEM (tech) jobs previously held in the US are also subject to outsourcing [40]. The numbers are not adding up when it comes to STEM job projected statistics, and the numbers are further compromised by the high attrition rate of STEM graduates and other unforeseen statistical data.

Yet another criticism can be described as a boom-and-bust cycle, a shortage in STEM professionals which is followed by a boom of STEM professionals, shortly followed by the 'bust' again where the employment market is flooded with STEM professionals [40]. The overall idea of the boom-and-bust cycle is that there was no initial STEM professional shortage

in the first place [40]. One possible explanation of constant boom-and-bust may be that companies are promoting a shortage to keep salaries lower and the talent pool higher [40]. Indeed, it can be observed that the average salaries of STEM professionals has stagnated in comparison to non-STEM professions, a consequence of supply surpassing demand [40].

The difference between advocacy for STEM education and denying the need for exaggerated STEM education, at least in terms of the government, lies in the details; one view focuses solely on the near-term job market and meeting economic demands, whereas the view of the federal government stresses the long-term educational status and welfare of the nation as the bigger picture. It seems the heart of the matter may be that while the US may not need to fill STEM employment opportunities with college graduates, and this is the key point: *STEM education teaches skills that can be used in many professions, leading to a future with more opportunity.*

Perhaps the attrition rate of qualified professionals with STEM jobs can be explained as moving to non-STEM fields that offer more financial security, stable work hours, or even a promotion to a managerial role. A 58 percent attrition rate in ten years could also either mean STEM graduates are sought after in other non-STEM fields for their skills or the graduates finished college without a desire to work in their field, only driven by the desire to pursue STEM education for secure employment. Nevertheless, STEM education provides practical skills and marketability in the US economy, promotes problem solving and innovative thinking, and can provide fulfilling and stimulating professional lives.

2.8 Educational Theory

The information furnished regarding educational theory consists of methods aimed to effectively educate the scouts during summer camp at TVSR, in accordance with our educational goals. The educational theory focuses on STEM education best practices particularly for educating scouts about sustainability at the planned ECon site.

Maslow's Hierarchy of Needs

The psychologist Abraham Maslow proposed in 1943 that [41],

“...people are motivated to achieve certain needs. When one need is fulfilled a person seeks to fulfill the next one, and so on.”

Figure 30 below depicts the steps an individual must climb to achieve peak experiences by realizing full personal potential [41]. As the theory describes, each person is focused on one level of need at a time, and must achieve the lower need to move on to the higher need [41]. It is possible for anyone to move up to any level, but because of individual circumstances and experiences, some people may seldom if ever reach upper levels [41].



Figure 30 - Maslow's Hierarchy of Needs 1954

Maslow continued to develop his list of need levels, and expanded from the five original needs in Figure 8, to eight needs [41]. These needs include cognitive, aesthetic, and transcendence, all of which are around the top of the original hierarchy [41]. Maslow believed that only one in a hundred reached the top, largely due to society mainly rewarding the esteem and love needs [41].

Maslow Criticism and Updates

Maslow's theory of hierarchical needs was written over fifty years ago, and has since been subject to scrutiny. It is important to understand the direction of these scrutiny's in order to properly gauge the accuracy of Maslow's theory as a useable educational theory.

One critical review suggests that Maslow's theory is correct in universal human need, but the order in which they are needed is not accurate, whereby equating the needs to vitamins [42]. Though Maslow has put emphasis on the individual, it is now thought that happiness is a combination of these individual needs in conjunction with social needs [42]. Though this criticism targets the process of Maslow's original needs, the needs themselves remain relatively unchanged, especially the basic ones.

Another critical review includes a possible path of evolution for the Hierarchy of Needs theory. As seen below in Figure 31 below, a new hierarchy is proposed with parenting on top, replacing self-actualization [43]. It is proposed that the need to pass on knowledge in the form of parenting is a paramount human need in all cultures, as well as a biological need [43]. Part of this new theory is that the needs overlap and co-exist, as may be seen in the figure 31 [43].

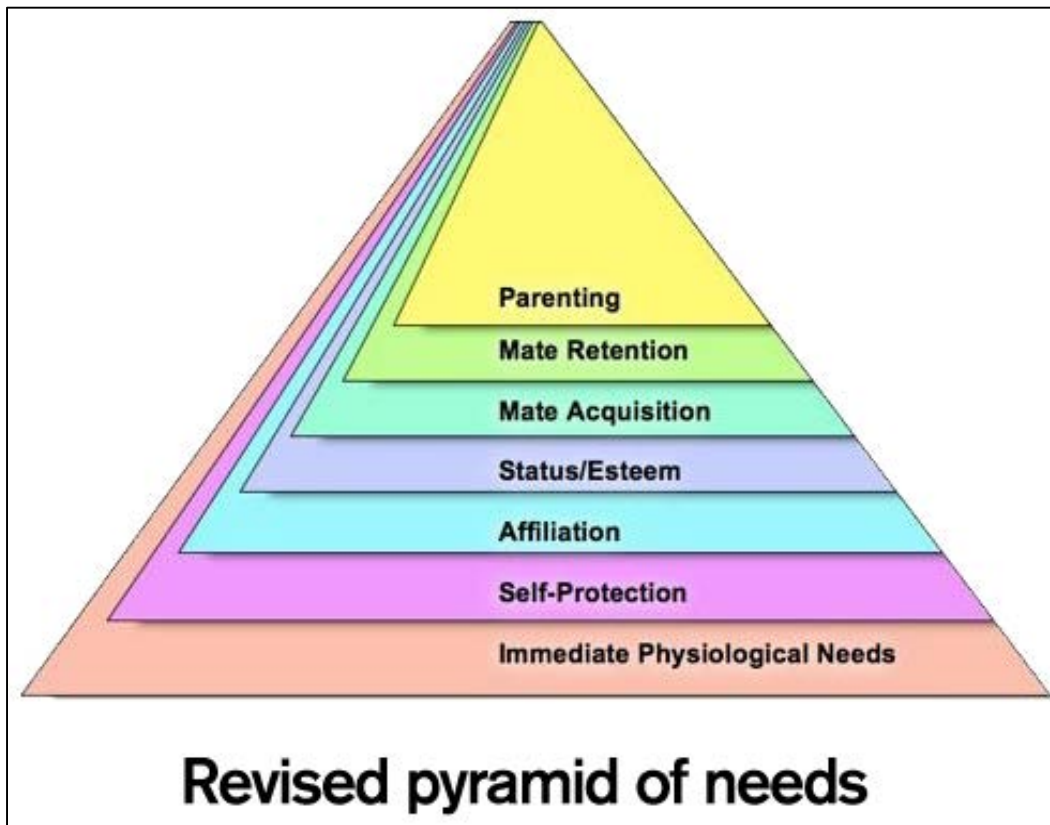

Figure 31 - Modern version of Maslow's Hierarchy of Needs

It can be concluded that Maslow's Hierarchy of Needs is not wrong by modern standards, but rather in need of conditioning and further study. In both criticisms, the basic workings of the model is the same, with the differences focused on the final resultant goal of self-actualization. While the resultant product of Maslow's Hierarchy of Needs is currently debated, the original theory may be regarded as sound and appropriate for educational goals.

Federal Aviation Administration (FAA) Perspective

The FAA created an [Aviation Instructors Handbook](#) (AIH) specifically designed to aid new aviation instructors learn educational techniques [44]. The AIH material describes aspects of teaching and learning psychology practical for flight training [44]. Though used for flight training, the educational theory may be transferred to scouting instruction. One of the many sections of the handbook discussed here is human behavior.

“The study of human behavior is an attempt to explain how and why human function the way they do. ...In the scientific world, human behavior is seen as the product of factors that cause people to act in predictable ways [44].”

Using human behavior theory, an instructor can observe the student to assess how students are attempting to meet individual needs [44]. Using the information gathered about the students, the instructor can then tailor the instruction to work best with the particular students' tendencies [44]. On the other hand, the instructor can better accommodate to the student by observing his

own behavior to find teaching strengths and weaknesses [44]. One way to explore this theory is through the study of personality types [44].

“Research has led many educational psychologists to feel that based on personality type, everyone also has an individual style of learning...[and] working with that style, rather than against it, benefits both instructor and student [44].”

Personality theory suggests that when instructors adapt to the students learning style, the student can remember more information, better retain information, use the information practically with higher efficacy, and maintain a generally positive outlook regarding the learning experience [44]. In today’s computer age, it is easy to go online and take a free personality test to better know yourself and others [44]. Personality theory has also become a powerful tool in non-educational fields, aiding in career choices and online date matching to name a few [44]. To conclude, the instructor can be more effective by recognizing the individual personalities of the learners in the classroom, and personalizing instruction to meet higher educational goals.

Another useful discussion in the AIH regarding scouting education is the topic of motivation. Motivation can come in many forms, from self-interest to social status, but all types of motivation provide a reward of some kind [44]. Knowing why the learner is electing to sit through instruction can be useful in terms of providing a good learning experience for the student [44]. Discovering what motivates scouts from the ages of 10 to 18 could also help distinguish the scouts’ personal learning style, and help to keep scouts learning throughout the course.

Once a student is motivated, keeping the student motivated is important for long-term goal achievement. One way to do this is to continually reward accomplishment and good deeds throughout the course [44]. In addition to rewarding success, new challenges should be presented to keep the student engaged [44]. An important fact is that learning is not a straight ramp upwards, but rather a series of peaks and valleys, as learners will seem less motivated and frustrated after a time [44]. In this circumstance, students should be reminded of their original interest in learning and encouraged to keep working hard to see results [44]. Knowing and implementing techniques that keeps the scout motivated can keep the scout focused in the sensory rich outdoor classroom.

Education in the Natural Environment Study

Scouts encounter the outdoors in almost every aspect of their residency during camp, many of the activities physically including nature and natural experiments. This study provides insight to how children learn in an outdoors residential program.

Through a study done in Environmental Education (EE) for 4th and 5th grade students [45], the learner had heightened experiences through sensory stimulation. Self-managed free time in an EE residential program allowed students to make meaningful connections with nature by seeing, hearing, touching, and smelling during their prolonged exposure to nature [45]. Scouting programs at TVSR provide a similar learning environment to this study, such as submersion in

nature and temporarily residing at the location. The study implies that if the learner is given more choice and control over exploration time in the real world, then the student will make deeper personal and education progress [45].

A second result of the same study was how the students took their sensory perceptions, and discussed them socially with peers and adults [45]. The ability to share and discuss with peers served as another educational experience by making the real-world experience through the senses more memorable and descriptive [45]. Additionally, the interaction with instructional staff and other adults about their individual experiences in an informal setting, such as meals, campfires, etc., provided other personal and educational fulfillment [45]. Students gained additional information, different perspectives, and fulfillment in the desire to share with an adult by having intermittent access to instructors and other adults [45].

The Importance of Peer Learning

The traditional classroom is comprised of a group of students gathering information from an instructor doing a monologue-style lecture. Scout camp provides more of a communal atmosphere in natural surroundings, encouraging a non-traditional classroom ambiance where students engage with their surroundings and others. Discovering more about peer learning can also lead to a rich individual learning experience. Peer learning can be defined as learning with and from others, and described as not independent, composed of various activities, and providing a mutually educational experience for each party involved [46].

“Students learn a great deal by explaining their ideas to others and by participating in activities in which they can learn from their peers. They develop skills in organizing and planning learning activities, working collaboratively with others, giving and receiving feedback and evaluating their own learning [46].”

Peer learning can be both effective and ineffective, depending on its implementation [47]. A planned, structured, and well led group activity with diverse groups of students generally has positive results, opposed to the instructor putting groups together and simply hoping for the best [47]. Using an effective method of peer learning can provide for a give and take educational experience for programs in scouting, allowing more knowledgeable scouts to fill in detail gaps for the less experienced scout while developing skills by rediscovering and effectively communicating the known material.

Educational Theory Summary

The case studies and theories above indicate effective methods to educate students and guide instructors. Understanding the students’ needs inside and outside the classroom can lead to a better understanding for an effective instructional approach. Likewise, the ability to identify the personalities and motivations of the student can lead to personalized, efficient instruction. It can be concluded that educational experiences are more memorable and the knowledge longer retained, when both physically interacting with the educational subject matter and interacting

with peers. These techniques should prove useful to the student and instructor when educating in an outdoors setting such as TVSR.

2.9 Background Summary

The information in the background was provided to better understand the contents of this reports' results and recommendations, and create a basic knowledge base supporting our projects' goals. Electrical history and background information can be used to understand the basic operation of the solar system installed at ECon and the other various hard shelters around TVSR. Solar power financial incentives can aid in the future installation of other renewable energy by benefiting from the programs offered by the government and crowd-funding. Educational information about scouting advancement and theory to assist being an effective learner and teacher can be used to efficiently plan and run programming to support STEM education at the ECon site.

3.0 Methods

This section details how we achieved our project goals. In general, our methods can be separated into two categories, solar system needs assessment and planning, and educational planning. Our methods included camp visits, formal research, measurement techniques, interviews, and other forms of information gathering.

3.1 Educational Planning Methods

Scout education methods were started by researching the BSA and the educational programs offered by the BSA. Because this IQP was focused on a solar energy sustainability study, a search was started to identify BSA educational opportunities that link sustainable energy generation to scouting. After having studied the Boy Scouts Requirements [31] book and the Boy Scout Handbook [9] to find educational requirements related to STEM and sustainability, we found certain merit badges and NOVA advancements that would be ideal through interacting with a solar system at the ECon building and other hard shelters at TVSR. By indicating the possible scouting advancements able to be completed through the various solar systems around TVSR, useful educational content that would benefit scouting and our sustainability/STEM goals could be conceived.

Educating scouts about a PV system at the ECon building coincided with a small number of BSA advancement requirements in the areas of ecology, environmentalism, conservation, sustainability, and others. This led to the discovery of a potential to reward scouts for learning about solar energy and the effects of clean energy. A detailed review of merit badges was conducted to determine which merit badges included requirements pertaining to the responsible use of energy, energy science, and the impact of energy with polluting byproducts.

After our initial BSA handbook, on-line and other forms of basic BSA policy, outreach, and educational methods research, interviews were scheduled with a scout executive and other staff to determine how scout camp education was structured to enhance STEM education. The various advancement opportunities were discussed and provided a direction for how to enhance educationally advanced content and practice. Specific topics discussed during interview and personal conversations included the following:

- The current programs implementing STEM and sustainability at TVSR
- Current issues preventing STEM education at TVSR
- The importance of STEM education in the grand scheme of TVSR
- Thoughts about the current solar system usefulness already at TVSR
- To what length is the expansion of solar energy and STEM education considered appropriate for the BSA at TVSR
- What electrical/safety standards must be lawfully upheld to install a solar system at ECon
- Ideas about ways to improve STEM and sustainability programs at TVSR

Since scouting is centered in the outdoors at TVSR, the aspects of social interaction and a close experience with nature allowed for a few educational theories to come to the forefront. Various educational theories, most notably the FAA manual, were studied to learn about practical education theory implementation.

STEM educational methods and BSA interests were investigated first through researching case studies to find best practices for STEM education outdoors. A meeting was held shortly afterward with a STEM professional and WPI professor to discuss how to approach STEM education in the setting of a Boy Scout camp. To continue the research into opportunities for BSA-STEM education, a STEM summit was planned for shortly after this IQP was completed to determine to what extent the STEM related educational goals at the ECon site were in the BSA's interests. Another goal of the summit was to discuss what the ECon site would look like as a center for STEM and sustainability, with the purpose of future site planning and goal setting. This summit was planned to be held at WPI, where BSA personnel, WPI faculty, and other related persons were invited to discuss the future of STEM and sustainability at TVSR and the ECon site.

During the solar system needs assessment and educational planning process, it had become evident that this project was only part of the larger objective of developing STEM and sustainability at TVSR, both through education and facility upgrading. Envisioning the path of STEM development continued as we realized our project had a limited scope, and by developing plans for the future of the ECon site and the project that may fulfill the visionary plans.

3.2 Solar System Assessment and Planning Methods

Our system assessment and planning methods started by visiting the ECon building and surrounding areas, and deciding where the PV equipment should go. Sun path measurements were made, and trees identified that need to be removed to make a solar installation practical. We specifically used the Solar Pathfinder for direct sunlight analysis by assessing the path of the sun in order to decide with accuracy which trees to recommend for additional removal. Using the SPF, we also decided how to place the panels, and consequently how far the transmission lines would have to travel from the panels to the ECon building. Educational goals were also an influence on the placement of the solar panels, deciding where the best placement would be for educational observation and interaction.

The ECon building contents and purpose were reviewed and documented through numerous (weekly) site visits. The total electrical load within was closely estimated and recommendations developed based on power/energy models, battery capacity, building needs, and building use. These figures were later cross referenced with information from ECon lodge camp staff through interviews.

The PV installation setup includes panel placement, transmission line installation, battery and charge controller installation, and the devices used in the ECon building. The placement of the

panels included an appropriate sun angle was researched on the web from solar installation recommendations. The transmission line path was measured with a standard measuring tape to decide how much wiring material was needed to traverse the gap between the solar panels and the entrance to the building. The batteries and charge controller requirements were selected based on the electrical load approximation, and the placement was decided with an emphasis on safety. The devices needed in the ECon building were researched and chosen to fit the energy generation of the solar panels. Several sections of the PV installation equipment were made possible through donation.

3.3 Methods Summary

Educational planning and electrical planning were reached through vigorous research and assessment. Several interviews with TVSR staff and other BSA Mohegan Council employees furnished the information needed to achieve our goals with a firm grasp of the needs of our Mohegan Council stake holders. On-site measurements and assessments allowed for accurate modeling of a PV installation to meet electrical energy needs at the ECon site. Through weekly camp visits, ongoing research, and scheduling meetings as needed, we were able to improve the status of our project continually.

4.0 Results

Our results section includes all the data gathered to recommend a self-sustainable solar energy installation, recommended BSA advancement requirements that may be met through the installation, and a possible future outlook of the ECon site regarding the sites' potential as a center for sustainability.

4.1 ECon Energy Needs Assessment Results

Investigating the original electrical devices used in the ECon building was an important step in discovering the energy previously needed at the site. The electrical hardware used in the ECon building revealed the capabilities needed from the solar installation. It was important to design an installation which could provide for all electrical energy needs of the building throughout the day and also at night. It was also important for the solar installation to be designed to consider future upgrades and increased electrical needs for the ECon building.

Once all the required electrical items were accounted for, the power consumption and operation conditions of each electrical item had to be considered. Best case and worst case scenarios were created with the determined electrical items to reach the solar installations' full energy potential. The energy provided by the installation must match the energy consumed by the devices for the installation to be sustainable, and often we were looking for devices that would draw the least amount of energy.

This section describes characteristics of each electrical item which is expected to be used in the ECon building.

Lights

The lighting in the ECon building provides the necessary light to teach in the building on a rainy day and during the night. During cloud cover or night, the lights will rely on the solar installations' batteries to provide the energy for lighting. The lights in the ECon building were originally comprised of 8 compact fluorescent bulbs. Compact fluorescent light (CFL) bulbs shown in Figure 32 offer good energy savings and extended life over standard light bulbs as explained in Figure 33. They typically operate on 120V AC and consume 10W to 30W of energy.



Figure 32 - Compact fluorescent bulbs [48]

Light Emitting Diode (LED) light bulbs can offer further energy savings than CFL with longer lifetime. In Figure 33, incandescent, fluorescent and LED light bulbs are compared. The first row shows the luminous efficiency in lumens per Watt for each type of light bulb. LED light bulbs are %75 more efficient than fluorescent light bulbs and almost 6 times more efficient than incandescent light bulbs. LED light bulbs initial purchase cost is high comparing to other types however its useful lifetime is 3 times of fluorescent and 60 times of incandescent light bulbs.

Parameter	Type of Light Bulb			
	Incandescent	Fluorescent	White LED	
			Circa 2010	Circa 2025
Luminous Efficacy (lumens/W)	~12	~40	~70	~150
Useful Lifetime (hours)	~1000	~20,000	~60,000	~100,000
Purchase Price	~\$1.50	~\$5	~\$10	~\$5
Estimated Cost over 10 Years	~\$410	~\$110	~\$100	~\$40

Explanation: Even though the initial purchase price of a white LED is several times greater than that of the incandescent light bulb, the total 10-year cost of using the LED is only one-fourth of the incandescent's (in 2010), and expected to decrease to one-tenth by 2025.

Figure 33 - Types of light bulbs compared [49]

Replacing traditional light bulbs with energy efficient LED lights can reduce the lighting energy demand for the ECon building significantly. Figure 34 below is a picture of one of the 8 LED lights which are proposed for the ECon building. They are rated 6W each and designed to operate at 12V DC.



Figure 34 - 6W LED light.

Heating Rock

The ECon building's role in TVSR necessitates various different animals to be available in the building for the scouts to study and observe. A Boa constrictor snake is one of the animals in the building and is available to scouts to study from morning to evening. The snake is moved to a different building in the evening and returned to the ECon building every morning. Snakes are cold blooded animals [50] and require a heating rock to keep their body warm. A heating rock as shown in Figure 35 below is recommended to create a suitable habitat for the Boa snake in the ECon building. The proposed heating rock operates on 120V AC therefore needs an inverter to step up the voltage. Its power consumption is 5W.



Figure 35 - Heating rock

Refrigerator

The Econ building's backroom houses necessary many of the tools and food supplies to take care of the animals displayed in the large room. A small sized refrigerator with a freezer section is utilized to keep animal's food fresh. This refrigerator is also used to preserve fish and various other animal to be later studied by the scouts. The refrigerator is the most demanding appliance in the ECon building in which it needs to be operational 24hrs a day.



Figure 36 - Old Emerson refrigerator

The backroom of the ECon building previously had a small Emerson refrigerator pictured above in figure 36 which used 20W at 120V AC. The eco refrigerator pictured below in figure 37 is a specialty model designed for boats and recreational vehicles by Sunshine Works. It operated on 12V DC and uses only 5W which is a %75 reduction in energy consumption over the old refrigerator.



Figure 37 - New ECO refrigerator [51]

Cooling Fans

The ECon building has one large and one small room. Most of the activities are conducted in the large room, while the small room is used for storage. The large room has large windows with

screens which allow air circulation for the room however the backroom has only one small window and it can get very warm during the day. The interviews conducted with the leaders of the camp made clear that installing one or multiple cooling fans can significantly increase the comfort in working in the backroom.



Figure 38 - The old Holmes fan

The cooling fans are desired during excessively hot and humid days. The interviewees expressed that the usage of the back room is minimal, which indicates mainly cooling the large room. It must be also noted that the room temperature is generally higher on sunny days in which the electricity production by the PV panels are also respectively higher.

The ECon building has a Holmes Blizzard cooling fan pictured in Figure 38 which is rated 70W at 120V AC. The fan in Figure 39 which is made by Fantastic Vent is recommended to replace the Holmes Blizzard cooling fan for further reductions in energy demand. It operates on 12V DC and is rated only 13W.



Figure 39 - 12V DC fan [52]

4.2 ECon Energy Supply Assessment Results

One of the goals of this project was to supply the electrical energy demand of the ECon building through solar energy creation. Designing a solar system which can supply the entire electrical energy demand of the ECon building accomplishes multiple objectives such as promoting sustainability, providing visual and functioning aid for STEM education, and allowing scouts to complete certain badge requirements explained in the background section.

Table 2 below was created using the data gathered in the ECon building energy needs assessment results section. All the electrical hardware in use in the ECon building is listed with their associated electrical energy demands. Table 2 displays the hours of operation for each hardware and total electrical energy consumption in Watts. 4 different scenarios are created for 1, 2, 3 and 4 PV panel installations. Each scenario has checkmarks for each hardware item which is within the electrical energy creation limits of each design. This table was useful to determine how many PV panels are needed in order to supply the entire electrical energy demand of the ECon building with the current electrical hardware. In order to supply the entire energy demand of the ECon building, 4 PV panels need to be integrated into the solar installation setup. With 4 panels, the electrical energy creation is 1600W and estimated energy consumption is 1599. Some days the solar energy creation can be lower due to bad weather conditions or the demand can be higher due to added new hardware such as cell phone chargers and laptop computers. It is desirable to have higher supply value than the demand. For this reason, two other options were considered. One option is to install more panels and the other option is to replace each electrical hardware with the energy efficient equivalents suggested in the ECon energy needs assessment results section.

Energy Needs with Old Existing Electronics					
	Hrs Operating/day				
# of Panels		1	2	3	4
Watt-Hr	4	400	800	1200	1600
CFL Lighting 8x - 104W	4		✓	✓	✓
Heat Rock - 9W	12	✓	✓	✓	✓
Fridge - 20W(estimate)	24			✓	✓
Cooling Fan - 75W	8				✓
TOTAL WATT-HR USED		108	524	999	1599
*Panel power is derated 50% from 215W to 100W, for inconsistent sun scenarios (cloud cover, rain, etc.)					

Table 2 – ECon energy needs with existing electronics

Table 3 below has the current hardware items replaced with the higher efficiency versions recommended in the ECon building energy needs assessment results section. The same four scenarios are applied for this table. Due to lesser electrical energy consumption of the proposed

hardware, the demand was met with only two PV panels. The estimated demand for all the hardware is 633.6W whereas the supply with two PV panels is 800W with over 160W extra energy remaining in this scenario.

Energy Needs with NEW Electronics					
	Hrs Operating/day				
# of Panels		1	2	3	4
Watt-Hr	4	400	800	1200	1600
LED Lighting 8x - 48W	4	✓	✓	✓	✓
Heat Rock - 9W	12	✓	✓	✓	✓
Mini Fridge - 5W(tested)	24		✓	✓	✓
Cooling Fan - 27W	8		✓	✓	✓
TOTAL WATT-HR USED		300	634	634	634
*Panel power is derated 50% from 215W to 100W, for inconsistent sun scenarios (cloud cover, rain, etc.)					

Table 3 – ECon energy needs with existing electronics

Integrating 2 PV panels into the final solar setup accomplishes the goal of supplying the entire electrical energy demand of the ECon building with the proposed electrical hardware with only 160W margin. For a higher margin a 3rd PV panel can be added to the system.

One Line Diagram

A one line diagram can be useful for simplifying the electrical representation of the entire electrical setup of the ECon building. Figure 40 is the one line diagram created for the ECon building solar installation setup. 2 PV panels on the left are connected to the charge controller in the center. The charge controller regulates the Voltage for the system and charges the battery connected below. Each load is represented with an appropriate resistor value and the LED light bulbs are represented with a yellow light bulb. The 2 PV panels provide electrical charge during the day. The charge controller routes this charge to the batteries and the system. The charge controller stops the current to the batteries when the battery charge level reaches full. At night the charge controller utilizes the batteries to power the system. The charge controller shuts off the system when the batteries' charge level reaches 20%.

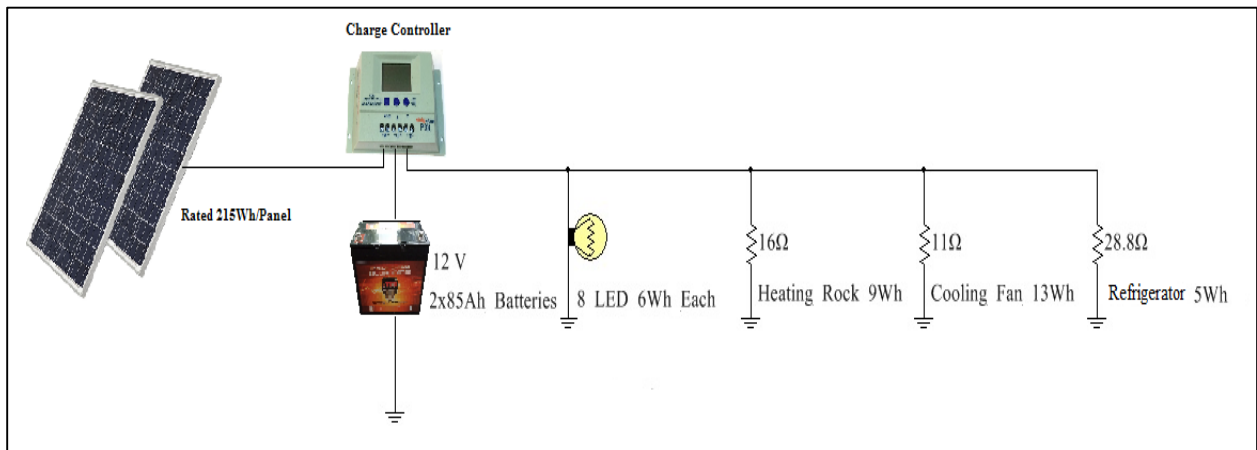

Figure 40 - One line diagram

Detailed Electrical Schematics

A detailed electrical schematics can be useful to study power losses on the wires on the ECon building electrical setup. Below detailed electrical schematics in Figure 41 was created with the circuit design simulation software [Multisim](#) for the ECon building. The simulation was later revised for added room details such as doors and walls. Each load is represented with an appropriate resistor value and each LED is represented with a yellow light bulb. The solar installation except the PV panels is also integrated to this schematics.

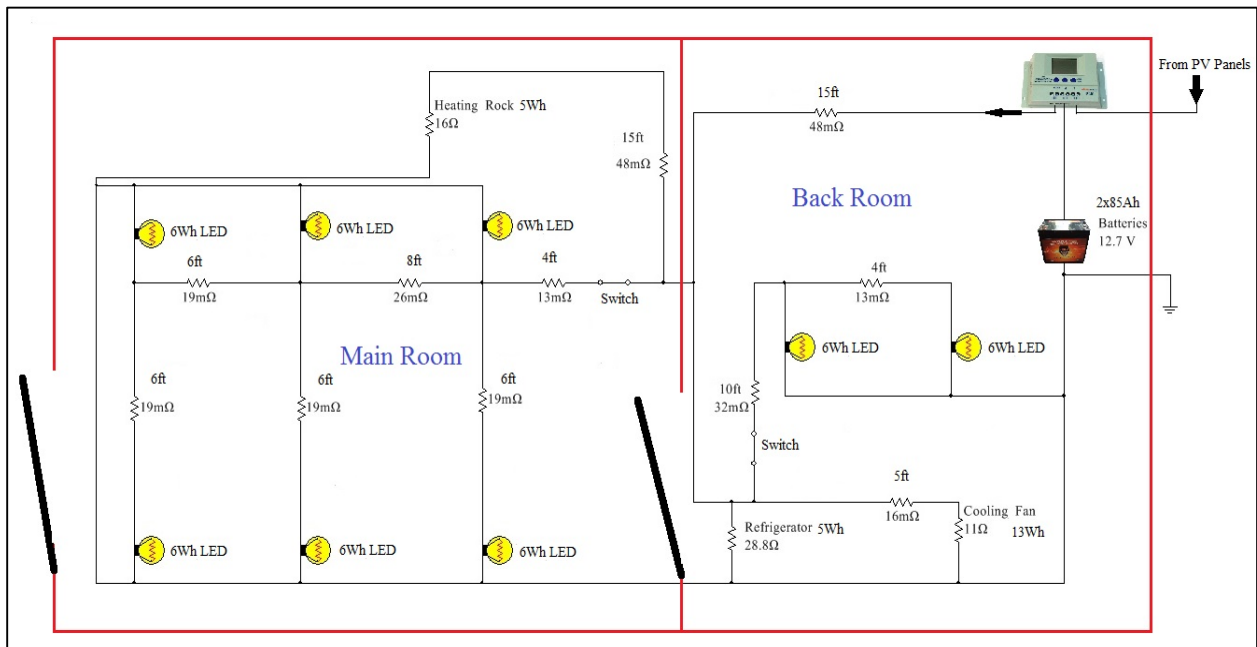

Figure 41 - Electrical schematic of the ECon building

The Multisim software allowed each power losses at each of the loads to be determined without making complicated calculations. The most critical electrical load was the LED light bulb located near the main entrance door. This LED light bulb is the farthest electrical load from the

supply with longest electrical wire run which results the highest electrical power loss. Below Figure 42 is the voltage reading of the simulated multimeter result for this LED light bulb. The supply battery voltage is 12.7V and the simulated multimeter reads approximately 12.1V. The proposed LED light bulbs were tested to work safely between 10V and 14V in a laboratory experiment earlier therefore the power losses are negligible. The power losses are expected to be lower on the other electrical loads due to shorter electrical wiring lengths applied in the setup.

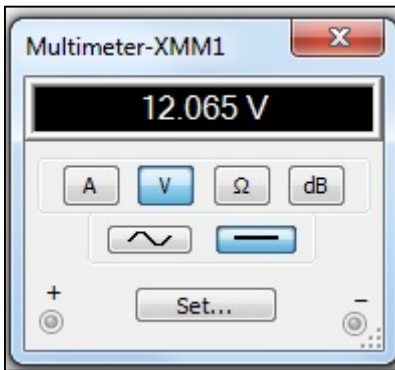

Figure 42 - Simulated power loss

4.3 ECon System Components Assessment Results

The ECon building energy needs and supply assessment results sections provided enough information to select the right components to design and build a solar system for the ECon building. Figure 43 below is a simplified graphical representation of the solar system proposed for this project. The solar setup consists of PV panels, a charge controller, batteries, Voltage meters, a timer and fuses. The PV panels convert sunlight into electrical energy. The charge controller directs this electrical energy to the batteries and the main system. The charge controller stops the electrical energy flow to the batteries when the battery charge level reaches full to avoid overcharging which would cause damage to the batteries. At night the charge controller utilizes the batteries to power the system. The charge controller shuts off the system when the batteries' charge level reaches %20 to protect them from fully depleting which would cause damage. A timer is utilized to limit the usage of the LED light bulbs to a specific time frame to avoid any user error such as leaving the LEDs turned on during the day. Multiple fuses are incorporated to protect the system and users from overloading the system or its individual components. Voltage meters are used for monitoring the solar energy generation and battery charge levels. The recommended components and their specifications are discussed in detail in subcategories in this section.

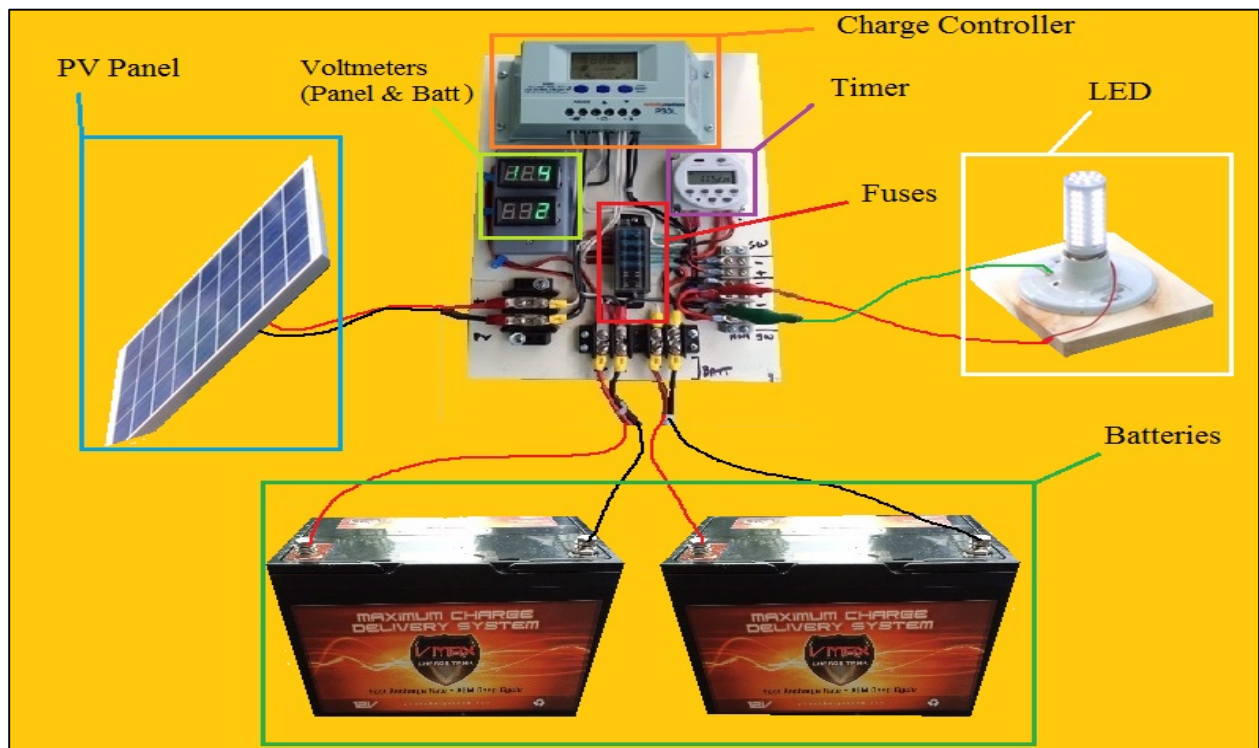

Figure 43 - Solar setup components

Panels

Two PV panels were available for the ECon building solar system installation. One of these panels with an attached specification sticker on the back is pictured in Figure 44 and 45 below. The panel is rated at 215W, but it is expected to generate on an average of 100Wh during the day due to variation in sunlight. During peak sun hours it is possible to expect power generation up to its rated output of 215W. The variation in the output is due to factors such as the changing sun beam angle and the changing sun intensity at different hours of the day.



Figure 44 - 215Watts PV panel.

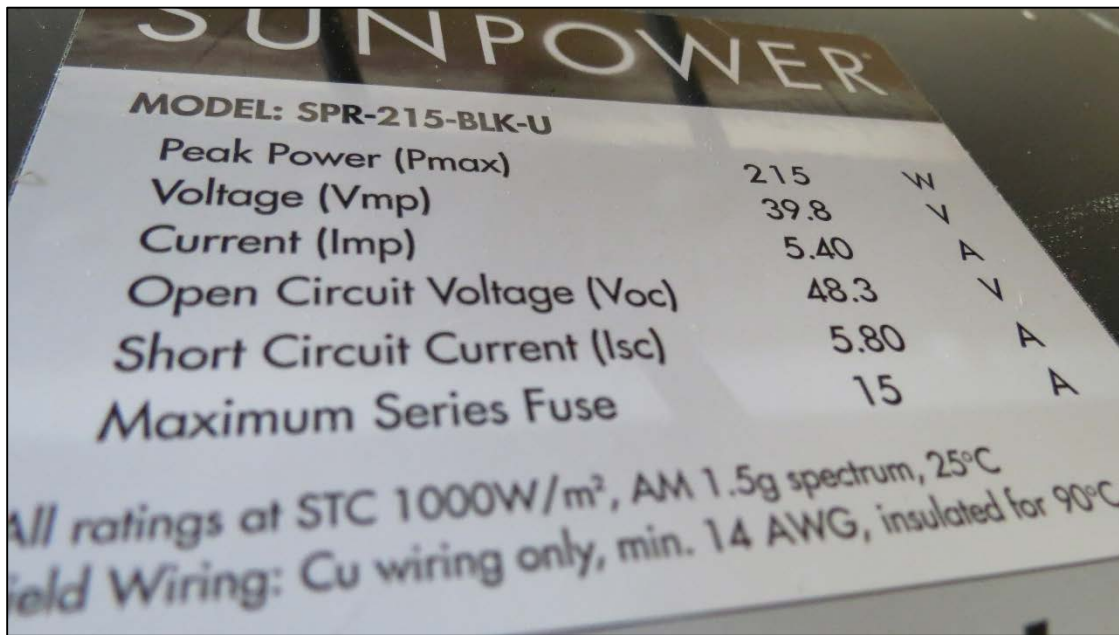

Figure 45 - Specification sticker on the back of the panel

Mounting

Mounting the PV panels at the most optimum location for the best sunlight exposure and satisfying an educational aspect of the project required considering different mounting options. The mounting option considerations included wall mounting, roof mounting and ground mounting. The research performed for the background section determined that the PV effect is increased to its maximum potential if the angle of the sunbeams are perpendicular to the panel's surface area. This could be achieved with all three mounting options. The educational theory study performed for the educational background section suggests that hands on education with visible aids is the best method for effective education. The wall and roof mounting options proved difficult to assist scouts in solar setup education due to their difficult to reach location. However the ground mounting option accomplishes the educational aid goal of the project.



Figure 46 - Custom made ground mounting equipment for the solar panels.

A ground mount is recommended for this project to house the 2 available PV panels. The recommended ground mounting equipment design can be seen in Figure 46 above. Two-by-four lumber can be used to custom build this mount, at a suggested angle of 45 degrees. Recommended measurements are approximately 10 feet wide and 4 feet high which can support two PV panels, one on each end. Leaving room for an additional PV panel in the middle for future upgrades is also recommended.

The ground mount allows the panels to be positioned at the most optimum location around the building where they get the most direct sunlight. In addition, this allows the scouts to better view the panels. To determine the optimum location for the panels, the solar path finder was used at multiple locations nearby the ECon building.

To determine the optimum location for the panels, the solar path finder was used at six different locations nearby the ECon building. These suggested locations are marked with an “x” on the picture in Figure 47, and the optimum location is circled. A bird’s eye view of the site with the recommended location of the ground mounted panels can be seen in Figure 48.



Figure 47 - Solar path finder survey locations

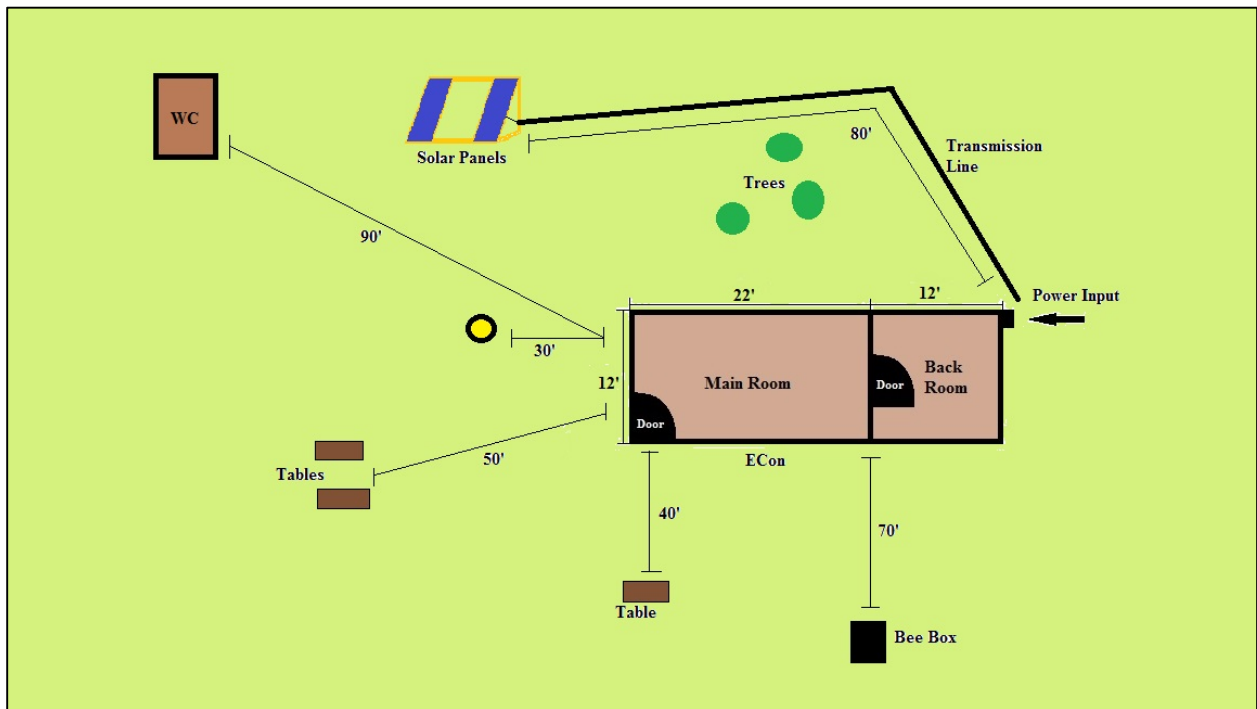

Figure 48 - Bird eye view of the ECon building site

Tree Removal

The ECon building site is located in a densely forested area. The solar installation requires hours of direct sunlight to generate dependable energy. The shading from the trees in the ECon building site needed to be removed to allow the sunlight to reach the PV panels on the ground. In anticipation of the lack of sunlight, some trees were removed by the authorities at TVSR before this project officially started; however, the preemptive removal was not sufficient for the goals of this project.

The Figure 49 below indicates an overall idea of the sun path at the site from where the panels are located, and shows the trees identified for removal in order to provide at least four hours of direct sunlight in the summer months.

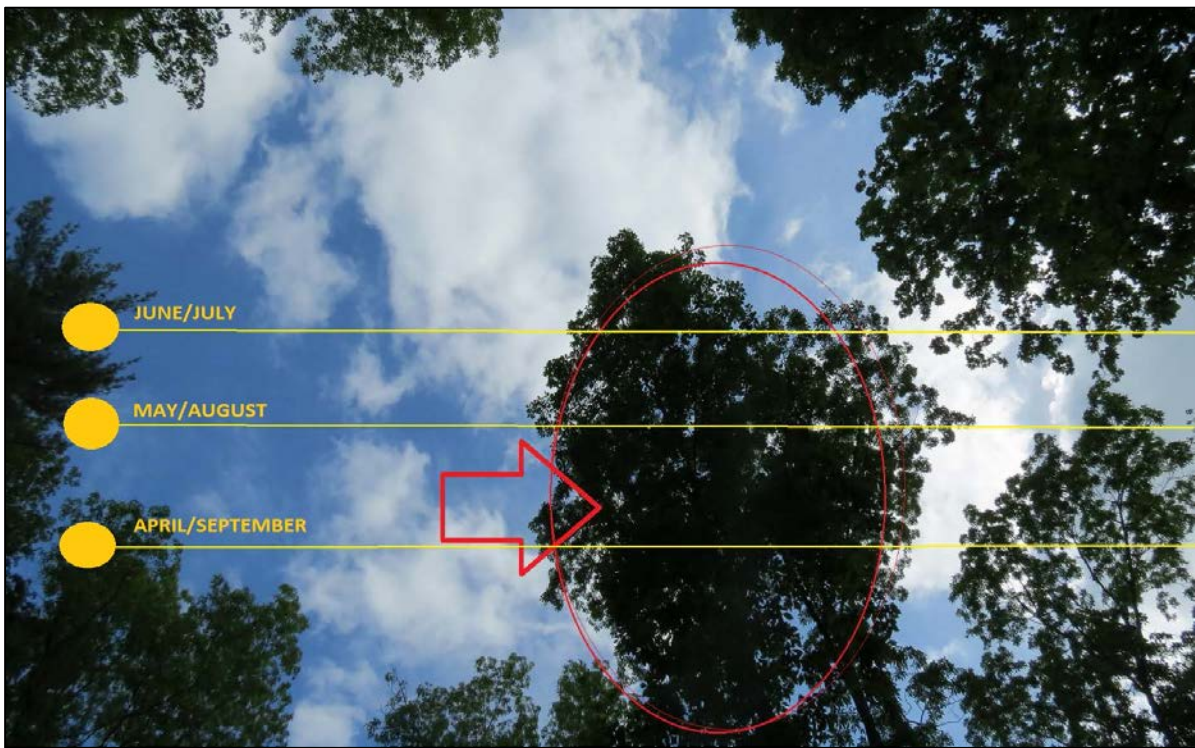

Figure 49 - Path of the sun and blocking trees

Transmission Line

The PV panels are ground mounted approximately 80 feet southwest of the ECon building. The solar energy created by the panels needed to be transferred into the building via a transmission line. A transmission line is an electrical wire which carries electric energy between the source and the loads. Gauging and the length of the wire must be selected carefully.

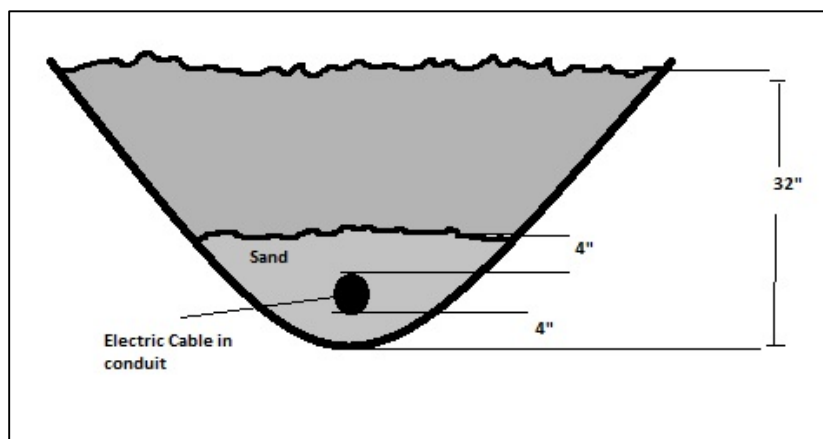

Figure 50 - Transmission line trench.

Safety is an important measure in the ECon building solar installation project. Although following the electric code for low voltage solar panel installations isn't obligated, the appropriate safety measures within the electric code is recommended for to this setup. Electric

code dictates any high voltage transmission line which is to be buried under ground must at a depth of at least 32 inches [53]. There must be 4 inches of sand above and below the transmission line as shown in figure 50. In addition, the transmission line should be concealed inside a conduit.

The ECon building transmission line is recommended to be consisted of two 100 feet 12 gauge romex wires concealed and buried underground between the PV panels and the north wall of the ECon building. Each 12 gauge romex wire is rated to carry 20A of current safely per NEC. It must be noted only one of the two 12 gauge romex wires is needed for the recommended solar setup. The inclusion of the second wire within the transmission line is recommended for possible future upgrades with added PV panels.

Charge Controller

The ECon building solar system design includes a charge controller which will ensure the safety and reliability of the setup. The charge controller recommended for this design also regulates voltages going into the system. In figure 51, the Windy Nation P30L is the charge controller which is recommended for the ECon building.



Figure 51 - Charge controller

There are 6 connections on the bottom of the unit. Two connectors to the left are connected to the PV panels, two in the middle are connected to the batteries and the two on the right are connected to the system.

Batteries

The research conducted for the ECon building's electrical hardware needs suggested the electric energy is required throughout the day and night for the ECon building. Uninterrupted 24 hours of electrical operations in the ECon requires the electricity generated by the PV panels to be stored for usage when solar electricity generation isn't available. The storage units should be able to store electricity enough for multiple days in case of multiple consequent cloudy days which results in little to no solar electricity generation. Relying on electrical power through stored electrical energy for multiple days can result in discharging the storage units down to their minimum potential, thus requiring deep cycling ability. Furthermore, the use of battery energy

after the sun has gone down means the batteries could discharge to the minimum potential every day. This results in a charge-discharge cycle at least once per day. The storage units must be able to perform several thousand cycles in order to provide reliable operations for several years.



Figure 52 - 85Ah VMax Battery

The ECon building previously didn't have any back up system for power interruptions. The solar system design includes two 85Ah deep cycling batteries as shown in Figure 52 to be used as electrical energy storage units. These batteries will ensure uninterrupted operations when solar energy generation isn't available.

Timer

A timer is recommended for the lights to limit the usage of the LEDs only at night. Figure 53 is the picture of the timer recommended for this purpose in the ECon building. It allows the light to be turned on only programmed hours. This helps avoid lights to be accidentally left on during the day or late night. In Figure 54 the instructions to operate the timer is printed on a sheet and displayed. There is also instructions to turn the light on or off manually on different times.



Figure 53 - Timer

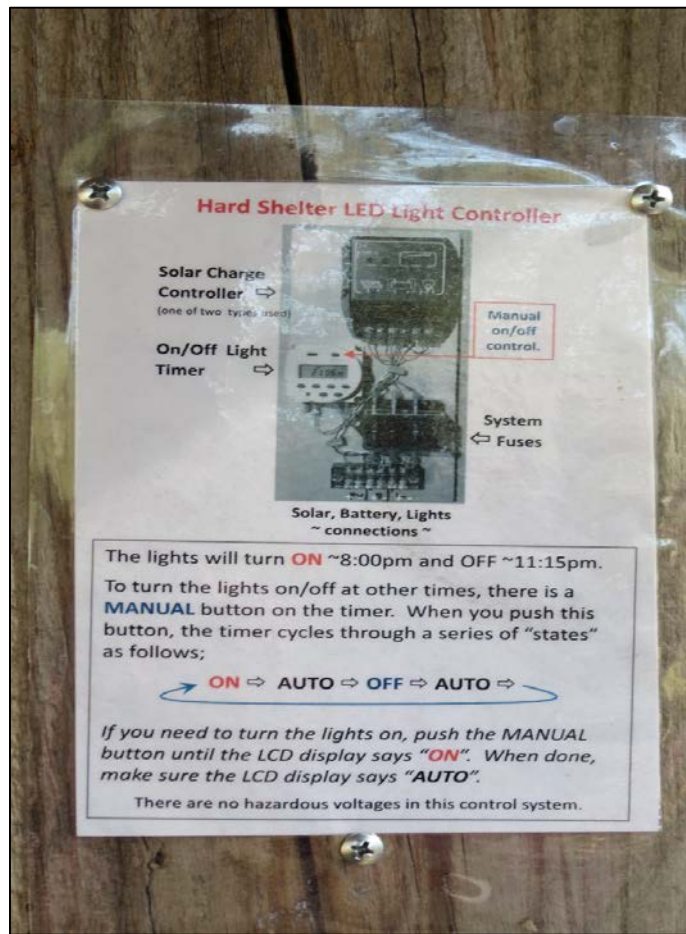

Figure 54 - Instructions

Fuses

Use of a number of fuses is recommended on the ECon building setup. The fuses protect the system and the operator for shorts and overloads. If the PV panels output exceeds the tolerance of the charge controller or other components the fuses blow and protect the system. Each component is recommended to have its own dedicated 5A fuse. Figure 55 shows the fuses for the charge controller, PV panels, batteries, and the main system. Each battery and PV panel also have fuses on their terminals for added security.

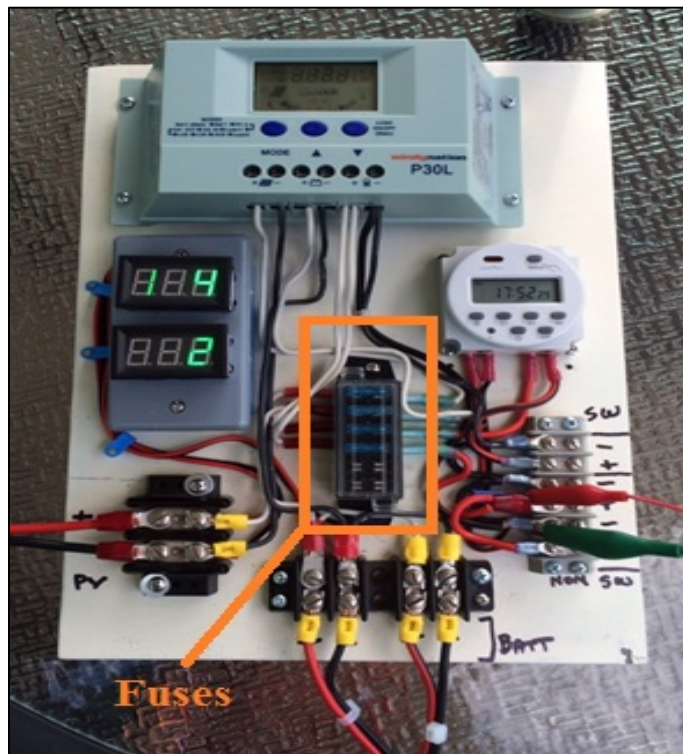

Figure 55 - Fuses

Inverter

An inverter is needed for powering the heating rock for the reptile tank. The 100Wh pure sine inverter as shown in Figure 56 is recommended for this purpose. The heating rock only consumes 5Wh therefore this sine inverter can be utilized for other duties as well in the future. One possibility is adding an additional heating rock in case the reptile demands more heat.



Figure 56 - Pure sine inverter

4.4 Educational Results

In this section, various merit badges and their requirements will be described. For each badge, the relationship will be made to various educational topics, including electricity, environmental studies, sustainability, and STEM education. Following the merit badge descriptions, a similar analysis will be presented with NOVA requirements.

Merit Badges

This section of the project highlights merit badge requirements that are applicable to sustainable studies and, in particular, requirements that can be addressed through hands on activities and related studies focused on the various solar systems installed at TVSR. For each merit badge description below, the BSA requirements are displayed in italics, followed by a statement of how the various TVSR solar installations can be used to enhance requirement completion.

Electricity Merit Badge

“Electricity is a powerful and fascinating force of nature. As early as 600 b.c., observers of the physical world suspected that electricity existed but did not have a name for it. In fact, real progress in unraveling the mystery of electricity has come only within the last 250 years [54].”



Figure 57 - Electricity Merit Badge [54]

4. Explain the difference between direct current and alternating current.

Direct current can be explained and measured using any of the solar system at TVSR. Alternating current can be explained and demonstrated using the DC to AC inverter and a portable oscilloscope, with proper safety precautions and supervision, at the TVSR ECon building. Use a portable oscilloscope to demonstrate the differences between AC and DC system voltages and characteristics. Sketch the differences in waveform, the voltage levels and be able to explain why the waveforms are different, the advantages and disadvantages of each, and why the voltages are different. Finally, explain the DC voltage circuits, components and systems for a hard-shelter solar system at TVSR.

7. *Explain what overloading an electric circuit means. Tell what you have done to make sure your home circuits are not overloaded.*

Overloading can be taught through understanding the current limits inherent in various electrical components, wiring and systems. Current overloading is prevented by using fuses or circuit breakers designed to “open” a circuit when over-current is detected. Any of the TVSR solar systems can be used as a hands-on demonstration of how circuits are protected from overloading by showing the circuit fuse systems, and explaining how devices draw power from the energy source through the wires. Through further explanation of wire ampere capacity and device energy needs, overloading can be exemplified.

8. *Make a floor plan wiring diagram of the lights, switches, and outlets for a room in your home. Show which fuse or circuit breaker protects each one.*

The ‘room in your home’ can be the entire ECon building. The merit badge counselor or MB mentor should point out all of the components of the ECon building solar system, starting with the PV panels, the wiring connecting the panels to the building, the protection and control systems, the power distribution systems, and the energy storage (battery) and power conversion (inverter) systems. Walk the scout around the building and point out the components as the scout sketches a diagram of the system. The fuse blocks should be explained in terms of what is protected and why. A spare fuse may be used for display. Do not pull the fuse from the installation except under direct supervision of a knowledgeable mentor or MB counselor.

9. *Do the following:*

1. *Discuss with your counselor five ways in which your family can conserve energy.*

A few different ways to conserve energy at home can be illustrated by the ECon building solar system. After being informed about the installation, a few ways to conserve energy would be to use low energy devices, use energy controlling devices such as timers to reduce energy, use the devices only when needed, consider doing things manually instead of using an electric appliance, etc.

10. *Explain the following electrical terms: volt, ampere, watt, ohm, resistance, potential difference, rectifier, rheostat, conductor, ground, circuit, and short circuit.*

The MB counselor can use the ECon solar system as a model, walking around the entire system and pointing out all the components. The scout should sketch the system and include all the components. The scout should then be able to show the MB counselor on his sketch a working example of volts, amperes, ohms, resistance, potential difference, conductor, ground, circuit, and short circuit. The terms that are not modeled in the ECon solar system are rectifier and rheostat. A rheostat may be modeled as a light switch dimmer; as the switch is moved from end to end, the current provided to the light is increased or decreased by varying the resistance. A rectifier may be explained as the reverse operation of the inverter. The rectifier converts an AC signal to a DC signal, while the inverter converts a DC signal to an AC signal.

Electronics Merit Badge

“Electronics is the science that controls the behavior of electrons so that some type of useful function is performed. Today, electronics is a fast-changing and exciting field [55].”



Figure 58 - Electronics Merit Badge [55]

1. *Describe the safety precautions you must exercise when using, building, altering, or repairing electronic devices.*

When describing safety precautions, the components of the ECon solar system and the hard shelter systems may be used to show proper safety procedures. An easy way to demonstrate safety is with the batteries of the system by demonstrating how to connect and disconnect the batteries from the rest of the electrical circuit by first powering down all devices. Wearing gloves and eye protection, remove the negative (black) terminal connector from the battery first, and then remove the positive (red) terminal connector. When altering any electrical system, it is important to disconnect the energy source to avoid electric shock, as the shock may be lethal. Another way to achieve the same results is to identify particular fuses or breakers to pull or switch off before working on an electrical system. When reconnecting the batteries, make sure all electrical modifications are complete and well-connected and all conductors are insulated and tucked away. Make sure all the devices are switched off and reconnect the battery terminals in reverse order from disconnecting (red, then black).

2. *Do the following:*

- a. *Draw a simple schematic diagram. It must show resistors, capacitors, and transistors or integrated circuits. Use the correct symbols. Label all parts.*
- b. *Tell the purpose of each part.*

With the help of the MB counselor, the scout can point out and draw a simple schematic of the ECon building solar system. With the help of the MB counselor, the scout can reduce the entire system to a simple series circuit, with the reptile heating rock as the resistor, one LED light as a transistor (diode), and

superimpose a capacitor in parallel. Using a battery as the energy source, a realistic closed circuit schematic diagram may be drawn and labeled.

4. *Discuss each of the following with your merit badge counselor, and then choose ONE of the following and build a circuit to show the techniques used:*

- a. *Tell how you can use electronics for a control purpose, and then build a control device.*

With the aid of the MB counselor, the scout can observe and learn about the charge controller panel at either the ECon building or the hard top solar systems. On the charge controller panel, there is a control device called a timer that is programmed to allow current to flow at some times and restrict current at other times. A more complex control device called the charge controller device controls the amount of current flowing into the batteries to achieve maximum charging potential, and also regulates the voltage supplied to the electronics. The charge controller device also has the capability to shut off the power supplied to the electronics if the batteries have reached their depletion, which maximizes the lifetime of the battery and prevents battery damage.

5. *Do the following:*

- a. *Show how to solve a simple problem involving current, voltage, and resistance using Ohm's law.*
- b. *Tell about the need for and the use of test equipment in electronics. Name three types of test equipment. Tell how they operate.*

With the aid of the MB counselor the scout can be shown some ECon building solar system devices needed to solve a simple problem using Ohm's law. By using the batteries as the energy source and the heating rock as a resistor, a simple closed circuit can be drawn and evaluated with Ohm's law.

The test equipment may be modeled by using a multimeter, which can serve as several distinct pieces of equipment in one device. The most practical are the Voltmeter, Amp meter, and the Ohm meter. This device may be used with the supervision of the MB counselor around the ECon building solar system to show the voltages, currents, and resistances at certain terminals, such as light terminals and battery terminals.

6. *Find out about three career opportunities in electronics that interest you. Discuss with and explain to your counselor what training and education are needed for each position.*

There are several career opportunities that may be explored using the ECon building and hard-top solar systems. Solar panels are created from semiconductors, and career training in electronics and semiconductor physics provide for advances in that technology. Career training in power electronics and electrical engineering is necessary for a position creating devices such as the power inverter used for the reptile heating rock in the ECon building solar system. A third career opportunity in consumer electronics design, such as

designing light bulbs or the reptile heating rock in ECon, includes training in electrical engineering, animal science, and even materials engineering.

Energy Merit Badge

“Saving, producing, and using energy wisely will be critical to America’s future. If we are to leave future generations with a world in which they can live as well or better than we have, scouts and other potential leaders of tomorrow must begin the hard work of understanding energy and the vital role it will play in the future [56].”



Figure 59 - Energy Merit Badge [56]

3. *Show you understand energy efficiency by explaining to your counselor a common example of a situation where energy moves through a system to produce a useful result. Do the following:*

- a. *Identify the parts of the system that are affected by the energy movement.*
- b. *Name the system’s primary source of energy.*
- c. *Identify the useful outcomes of the system.*
- d. *Identify the energy losses of the system.*

The ECon building and TVSR hard-shelter solar systems may be used as a model for these requirements. Part (a.) may be completed by drawing a schematic of the installation from the panels to the load, and then identifying the system parts affected by the energy movement. The scout should become aware that every connected part of the solar system is affected by energy movement.

Part (b.) may be completed by identifying the three energy sources: working backward, the batteries (technically energy storage), the solar panels, and the primary energy source is the sun.

Part (c.) may be completed by recognizing the usefulness of the electrical output, namely the devices powered and their purposes. Another useful outcome of the system could be described as self-sustainable energy provided in a remote location, not having to rely on others for electricity. Yet another useful outcome of the system could be described as a cleaner and ecological method of energy

generation, generating energy without producing greenhouse gas or environmental waste.

Part (d.) may be approached with the help of the MB counselor by measuring segments of the solar system with a multimeter, and recording the voltages and currents on a hand drawn schematic of solar system. The student can then see where on the schematic where power was lost through wiring or the use of a device. The student may further prepare for energy loss recognition by drawing the solar system first and doing Ohm's law calculations, then comparing measured results. Another loss to be identified in the system is through the solar panels, by subtracting the power direct sunlight would provide on the surface area of the panel from the rated power of the solar panel. The scout must generally understand that there is some energy loss present in every part of the installation.

7. *Tell what is being done to make FIVE of the following energy systems produce more usable energy. In your explanation, describe the technology, cost, environmental impacts, and safety concerns.*

a. *Solar power systems*

To produce more useable energy, the semiconductor cells must be upgraded somehow. The silicon has physical limitations, and does not use all the energy in the light absorbed. To increase efficiency, it is possible to combine silicon cells with other layers of other semiconductor materials to maximize the range of light absorbed, and thus maximizing potential energy.

Cost is directly related to the efficiency and complexity of the semiconductors that make up the solar panels. Although consumer solar panels can be affordable, solar panels can also reach prices that ward off buyers. Generally, the more money you spend on solar panels, the better the quality. Another major cost to consider is battery storage, which is still in technological infancy compared to the rest of the technology involved. The batteries are the weakest part of the solar installation, and cost is consequently prohibitive to the consumer.

The environmental impacts, as discussed in the background, are very small compared to fossil fuels. Manufacturing semiconductors includes caustic chemicals, environmental waste, and emits some greenhouse gas. Otherwise, there are no greenhouse gases emitted when producing solar energy. In addition, the panels provide no chemical safety risk known after having been created, other than the suspected electrical dangers of generating energy.

Engineering Merit Badge

“Engineers use both science and technology to turn ideas into reality, devising all sorts of things, ranging from a tiny, low-cost battery for your cell phone to a gigantic dam across the mighty Yangtze River in China [33].”



Figure 60 - Engineering Merit Badge [33]

1. *Select a manufactured item in your home (such as a toy or an appliance) and, under adult supervision and with the approval of your counselor, investigate how and why it works as it does. Find out what sort of engineering activities were needed to create it. Discuss with your counselor what you learned and how you got the information.*

The manufactured item in the ‘home’ could be a device in the ECon building solar system. The easiest could be the LED light bulb, but other appliances working on the solar installation could be used. With the help of the MB counselor, the LED light can be represented in a sketch and used to explore the design of the device. Information about LED’s, diodes, semiconductors, and current-controlled devices should be enough background for the scout to understand the materials and design of the LED light. The scout should understand that engineering can be understood as the skills needed to solve specific problems. Engineering activities needed to create the LED bulb include circuit analysis, remote location power supply analysis, and the amount of lumens required to see adequately with the LED light.

2. *Select an engineering achievement that has had a major impact on society. Using resources such as the Internet (with your parent’s permission), books, and magazines, find out about the engineers who made this engineering feat possible, the special obstacles they had to overcome, and how this achievement has influenced the world today. Tell your counselor what you learned.*

The engineering achievement that could be focused on with the help the MB counselor and the ECon building or hard-shelter solar systems would be the creation of solar panels. The needed information could be provided for the scout by the MB counselor on the history of the solar panel and semiconductors, and how they are being used to shape the

world today. The counselor or mentor can then walk the scout around the solar system and point out the solar panels and the semiconductors that make them up.

6. Do TWO of the following:

- e. *Converting energy. Do an experiment to show how mechanical, heat, chemical, solar, and/or electrical energy may be converted from one or more types of energy to another. Explain your results. Describe to you counselor what energy is and how energy is converted and used in your surroundings.*

Energy conversion may be modeled with the ECon building or hard-shelter solar systems two ways. One way is for the MB counselor to bring the scout to the solar panels and explain the sun's light transforming to electrical energy through the solar panels. The scout can experiment by measuring the solar panels' area and record the rated power of the solar panel to compare to the power provided by the sunlight in the same area. The scout should discover the conversion efficiency of the sunlight energy to electrical energy.

The second way for the scout to learn energy conversion is by studying electrical energy converting to light energy in the LED lighting. An experiment in electric energy to light energy would be to use an electric power supply to supply the electricity to an LED light. Under MB counselor supervision, the scout may then slowly increase or decrease the voltage and current supply to understand the needed energy to produce light with the LED light. Another experiment could be to use a small solar panel to turn a light on while in the sun, but providing no light when in the dark.

Sustainability Merit Badge

“Planet Earth is our common home that provides us with the fundamental resources for survival. These resources, however are limited and can be depleted if we don't manage them carefully [57].”



Figure 61 - Sustainability Merit Badge [57]

2. *Do the following:*

Energy. *Do A AND either B OR C.*

- a. *Learn about the sustainability of different energy sources, including fossil fuels, solar, wind, nuclear, hydropower, and geothermal. Find out how the production and consumption of each of these energy sources affects the environment and what the term “carbon footprint” means. Discuss what you learn with your counselor and explain how you think your family can reduce its carbon footprint.*
With the aid of the MB counselor, the scout can walk around the solar systems at the ECon building or at the hard-shelters and discover the effects of solar energy generation on the environment to be free of emissions. After the scout experiences solar energy generation as emission free, the scout can then compare solar generation to something commonly known such as a cars' combustion engine. Each energy source can be described briefly with a few pros and cons, including the carbon footprint of greenhouse gasses produced while operating. Then, with the help of a MB counselor or mentor, the scout can learn how energy is provided to his home, and that the energy used around his home affects greenhouse gas (CO₂) emissions through the local power plant. The scout should then come to the conclusion that the way to reduce his carbon footprint would be to conserve energy at home by limiting device usage and driving vehicles only when required.

NOVA Requirements

To further suggest the educational benefit of the ECon building solar system at TVSR, this section shall include NOVA requirements able to be completed sustainable studies and energy studies in the STEM-based curriculum. The NOVA requirements are broken up into four modules for each STEM area, similar to merit badges. This section will include the requirements for both cub scouts and boy scouts. For each NOVA module description below, the BSA requirements are displayed in italics, followed by a statement of how the various TVSR solar installations can be used to enhance requirement completion.

Cub Scout NOVA Requirements

Science Everywhere Module

“This module is designed to help you explore how science affects your life each day [58].”

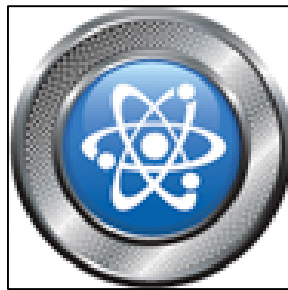

Figure 62 - NOVA cub scout module “Science Everywhere” [58]

3. *Act like a scientist! Explore EACH of the following:*
 - A. *With your counselor, choose a question you would like to investigate.*
 5. *What other activity can you think of that involves some kind of scientific questions or investigation?*
 - B. *With your counselor, use the scientific method/process to investigate your question. Keep records of your question, the information you found, how you investigated, and what you found out about your question.*
 - C. *Discuss your investigation and finding with your counselor.*

The scout may investigate the solar systems at the ECon building or the various hard shelters, inquiring how sustainable solar energy works with solar panels or how the energy of the sun is transformed into electrical energy. With the help of a counselor the scout can follow the path of electrical devices, from the panels to the transmission lines to the batteries, and gain a hands-on perspective of electrical energy creation with no CO₂ emissions. The scout may then hypothesize how the system works, and again with the MB counselor investigate the energy that is available on the earth's surface from the sun, semiconductor PN junction operation, and electrical conductors. The scout may continue by drawing

correct conclusions about sustainable solar energy, such as how the energy is created, how the energy is transmitted, and how energy generation may be sustainable and responsible.

4. *Visit a place where science is being done, used, or explained, such as one of the following: zoo, aquarium, water treatment plant, observatory, science museum, weather station, fish hatchery, or any other location where science is being done, used, or explained.*
 - A. *During your visit, talk to someone in charge about science.*
 - B. *Discuss with your counselor the science done, used, or explained at the place you visited.*

The scout may visit any of the solar system setups at the hard shelters or the ECon building at TVSR to observe electrical energy generation. All the solar systems include solar panels, wiring, batteries, a charge controller panel, and lighting. The MB counselor can walk the scout around the devices as the scout takes notes on what the devices are, how the devices work, and the larger scale role the devices play in the solar system. The scout may then draw his own diagram to illustrate the operation of a solar system, and the path the energy takes to get from the sunlight energy to the energy used by the electrical devices.

Tech Talk Module

“This module is designed to help you explore how technology affects your life each day [58].”



Figure 63 - NOVA Cub Scout module "Tech Talk" [58]

4. *Visit a place where technology is being designed, used, or explained, such as one of the following: an amusement park, a police or fire station, a newspaper office, a factory or store, or any other location where technology is being designed, used, or explained.*
 - A. *During your visit, talk to someone in charge about the following:*
 1. *The technology used where you are visiting*
 2. *Why the organization is using these technologies*

B. *Discuss with your counselor the technology that is designed, used, or explained at the place you visited.*

The educational suggestion for this requirement, is that same as #4 in the Science Everywhere module.

5. *Discuss with your counselor how technology affects your everyday life.*

The scout can learn about how technology can provide emissions-free energy through renewable solar energy generation. Using the ECon building or hard shelter solar systems, the scout can work his way from the devices that need energy, describe how they are important, and move the batteries to discuss how battery storage of electrical energy provides for many daily used devices. From there, the scout can continue toward the solar panels, and how renewable energy sources can provide energy without the emission of greenhouse gasses.

Boy Scout NOVA Requirements

Start Your Engines! Module

“This module is designed to help you explore how technology affects your life each day [59].”



Figure 64 - NOVA Boy Scout module "Start Your Engines!" [59]

2. *Complete ONE merit badge from the following list. (Choose one that you have not already used toward another Nova award.) After completion, discuss with your counselor how the merit badge you earned uses technology.*

*[Automotive Maintenance, Aviation, Canoeing, Cycling, Drafting, **Electricity**, **Energy**, Farm Mechanics, Motorboating, Nuclear Science, Railroad, Small-Boat Sailing, Space Exploration, Truck Transportation]*

The Electricity and Energy merit badges in bold above can either be completed in whole or in part using the ECon building or hard shelter solar systems at TVSR. Reference the merit badge section of the results to view the requirements recommended for completion in the Electricity and Energy merit badges.

3. *Do ALL of the following.*

C. *With your counselor:*

3. *Discuss alternative sources of energy.*

4. *Discuss the pros and cons of using alternative energy sources.*

The ECon building and other hard shelter solar systems can help the scout both discuss alternative sources of energy and pros and cons of using alternative energy sources. The scout may better describe solar energy as an alternative source by observing the panels as emissions free and using the energy from the sunlight to produce usable electric energy as a pro. The scout may then discover that the solar panels have limitations, and that the solar panels are only dependable when exposed to direct sunlight. Considering cloud cover, rain, night, and poor sunlight in the winter, the scout may understand the dependable limitations of solar energy generation as a con.

Whoosh! Module

“This module is designed to help you explore how engineering affects your life each day [59].”



Figure 65 - NOVA Boy Scout module "Whoosh!" [59]

2. *Choose ONE merit badge from the following list. (Choose one you have not already used for another Nova award.) After completion, discuss with your counselor how the merit badge you earned uses engineering.*

*[Archery, Aviation, Composite Materials, Drafting, **Electronics, Engineering**, Inventing, Model Design and Building, Railroading, Rifle Shooting, Robotics, Shotgun Shooting]*

The Electronics and Engineering merit badges in bold above can either be completed in whole or in part using the ECon building or hard shelter solar systems at TVSR.

Reference the merit badge section of the results to view the requirements recommended for completion in the Electricity and Energy merit badges.

4.5 Results Summary

The results of this project provide suggestions and recommendations for a solar installation at the ECon building, and also for the educational instruction to benefit scouting advancement while interacting with the ECon building solar installation. Electrical results recommend several energy saving devices that could be used to efficiently utilize the energy provided by the solar

system, and also provide schematics that detail the solar system from source to load. The educational results list merit badge and NOVA requirements that may be met through interaction with the ECon building and hard shelter solar systems, and suggest methods to complete the requirements.

5.0 Project Discussion, Recommendations, and Summary

The topics addressed in this section include our vision for the ECon site, thoughts about building and siting restrictions at the ECon site, and a section on expanding the ECon site to include new buildings and structures to enhance both year round use as well as shared ECon and STEM education programs. Section 5 will also present a summary of the recommendations developed and presented in earlier sections of this report, as well as provide a few additional recommendations that address the long term development and use of the TVSR ECon site. Finally, we will briefly describe a few third and fourth year WPI projects that could be used to further develop the ECon site into a center for sustainability.

5.1 Restrictions to ECon Site Expansion

Restrictions to the expansion of the ECon site entail some natural obstacles. The first restriction is the extent of tree cover in the area. Concerning the solar panel operation and achieving reliable results from the solar panels, direct sun is absolutely necessary to shine on the solar panel for a set number of hours a day. The trees surrounding and existing in the ECon site are tall canopy trees that provide lots of shading to the area, which hinders the solar possibilities of the ECon site. To expand the ECon building solar system to include more panels, trees must be removed. The Solar Pathfinder or a similar sun tracking device could be used to accurately and responsibly remove the trees that block the sun's path in an area being considered for solar panel placement. Below are a few maps outlining the area of the ECon site in Figures 66 and 67, followed by some pictures in Figures 68 and 69 that illustrate tree coverage in the ECon site.



Figure 66 - ECon site area topographic map [60]



Figure 67 - ECon site area satellite map [61]



Figure 68 - ECon site looking from East to West



Figure 69 - Shading in the East side of the ECon site

As seen in Figures 68 and 69 above, the sun is blocked from nearly all angles. Cutting trees would be most beneficial on the southern end of the ECon site due to the path of the sun, but a solar path measuring device would be needed to strategically remove trees where required. Further tree removal, all over the site but the East end in particular, would allow direct sunlight to reach solar panels at future solar system sites. The development of the site regarding tree removal is critical to generate enough energy for future energy needs. If enough trees were removed from the ECon site in general, the possibility of installing more solar panels, including on the roof of the ECon building, would be a useful addition to supplying future energy needs to the building.

Another restriction to further ECon site development is the existence of a vernal pool about 20 feet away from the ECon building. In the spring, a vernal pool manifests itself next to the ECon building, and drains just in front of the ECon building. Due to environmental regulations, the vernal pool may not be tampered with to protect the ecology in the area. Further the vernal pool is in close enough proximity to the ECon building, that creating a simple addition would be difficult without disturbing the annual vernal pool. The ECon site is illustrated below in Figure 70 with the location of the vernal pool, and a ground level picture of the vernal pool in Figure 71. It can be shown in the ground level picture that the pool is dry in the summer (taken late July), and a stone path has been created to mark the pool boundary for preservation.

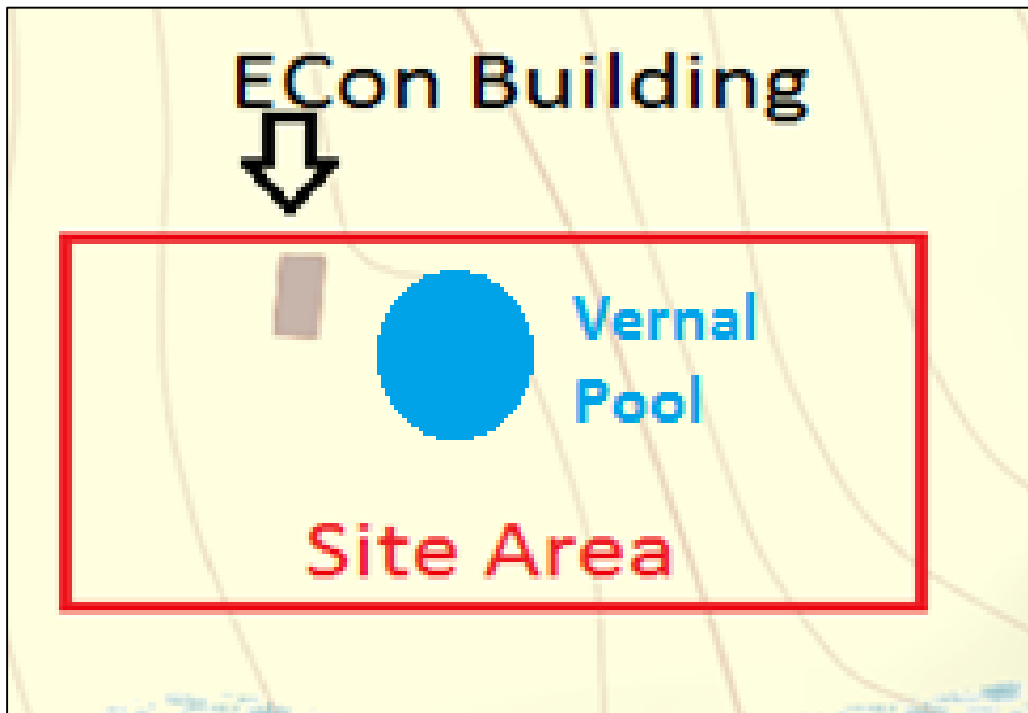

Figure 70 - ECon site with vernal pool [60]



Figure 71 - Vernal pool at ground level

If the vernal pool must stay, perhaps the vernal pool site could be taken advantage of. Ecologically speaking, the vernal pool could be used as a scouting educational tool, displaying the creatures and plants that belong to the micro-habitat. Highlighting the vernal pool by perhaps

building a walking deck around the site would turn this restriction into something useful. Though not related to energy sustainability, turning the vernal pool into an educational display would further develop the ECon site in a positive way, and may be used to further the ecology conservation achievements.

5.2 ECon site ‘Vision’

One of this projects’ goals was to ‘envision the future use of the ECon site as a center for STEM and sustainability studies’. The potential gauged through studying the ECon site and BSA objectives has provided a vision to combine ecology conservation, energy sustainability, and STEM into one connected sustainability center. The ECon site can continue to offer all the ecology conservation programs currently offered with the suggestions of this report, and may also expand their repertoire of ecology studies with future projects. In addition to ecology conservation, the recommendations of this project offer new possibilities for energy conservation programs. Through further site construction, modification, and planning, the ECon site could be equipped to serve as a model for sustainability education, particularly in the BSA and the programs provided for scouts.

1. Separate the ECon Site into Two Areas

The current situation at the ECon site lives up to its’ namesake, Ecology Conservation. The merit badges offered during summer camp at the ECon site include: environmental science, fishing, fly fishing, fish and wildlife management, forestry, plant science, reptile and amphibian study, and soil and water conservation. The merit badges that may be offered due to the ECon solar system at the ECon site listed in the results section 4.3 are different from the merit badges listed above, yet the two groups of merit badges both teach sustainability. The ECon site is large enough to be able to teach both groups of merit badges, and may benefit from splitting the site into an area for ecology conservation and a separate area for energy sustainability.

Planning for two separate areas in the ECon site will require further development of the available space. In the immediate future, the two areas may easily coexist; however, as both programs expand, the need for two distinct areas will become evident. The ecology conservation program at TVSR is currently using the ECon building for their purposes, housing equipment, animals, and wildlife specimen. The vision is to have two buildings, one for each educational area. Since the ecology program requires certain electrical needs, it may be recommended to share the back room of the ECon lodge for specimen storage in a refrigerator and perhaps night storage for some animals that need electrical devices such as a heating rock or a fish tank pump. The current ECon building could serve as the future energy sustainability building, while another building is proposed on site specifically for ecology conservation.

2. STEM Area at the ECon Site

Further planning to achieve the vision of a center for sustainability includes space available for STEM programs. Some NOVA requirements include building, designing, or learning about

STEM projects. The space available at the ECon site could be developed to include learning pavilions for STEM projects. The hard shelters available in many of the camp sites at TVSR could be built to provide the learning centers or project centers at the ECon site. Many NOVA requirements include building something or exploring projectile motion. Testing projectiles and other active equipment may be better at a site more suitable for testing with less forestation and more room for active experiments.

3. Year Round Use of the ECon Building

Another part of the ECon site vision is developing the ECon building to be used for energy sustainability education in the months before and after camp, and perhaps even all year round. The benefit to the BSA would not only serve as an educational outlet, but could also serve as a useable building during the winter months for any reason. The sunlight in the winter months is not strong in Massachusetts, thus preparations must be made to provide the solar panels with as much direct sunlight as possible. This can be done by cutting trees on the South side of the ECon site to allow sunlight to the panels when the sun moves lower in the winter sky. Angling the pitch of the panels further up in the winter would also be helpful in collecting direct sunlight, which implies a commonly used method of tweaking the pitch of the panels twice a year (summer pitch and winter pitch). If the batteries can be provided a certain amount of energy from the solar panels, all year use could be possible; though even more tree removal must be considered, because the sun's path is at the lowest point in the winter.

5.3 Development of the ECon Site into a Center for STEM and Sustainability

The new proposed building for ecology conservation at the ECon site could be located on the other side of the site in the south-east corner or in the northeast side of the ECon site by the vernal pool. Using the current ECon building for energy sustainability would be preferable considering the direct sunlight available next to the building. The new building for the ecology conservation studies could mimic the ECon building by including a solar system to provide the necessary energy for refrigerator storage and lighting as needed. The south-east corner of the ECon site is particularly shrouded by canopy trees, which would need to be studied for tree removal in order to provide direct sunlight in that location.

In addition to constructing another small building at the ECon site, another suggestion for additional buildings would be to construct a few hard shelters throughout the site. Currently, the ECon site outside the building comprises of wooden picnic tables under low-tied canvas tents to provide instruction in all weather, and protection of animals and equipment from the elements. Newly constructed hard shelters could additionally be outfitted with a solar system to provide lighting when needed as has been done at various camp sites at TVSR, and serve as an additional learning tool for energy sustainability. Hard shelters are superior to tented tables in both space and comfort, and would provide quality learning areas.

Finally, constructing an addition to the ECon building would provide the necessary space for program expansion, equipment housing, and device demonstration. This addition would include both more building space and additional solar panel installations. Additional solar panels would provide the necessary energy to power more devices for educational demonstration. The additional space provided in this expansion has many possibilities, but the recommended use for an energy sustainability building where students learn about energy would be to construct a laboratory room where scouts may interact with energy devices to provide a hands-on learning experience. The equipment used at such a laboratory could be as simple as electronics wires and AA batteries to build circuits. An addition to the ECon building would provide a two-room system, where learning is done in one room and experimenting is done in the other, effectively combining theory and practice.

5.4 Short-Term Recommendations

1. Replace all ECon lighting systems with LED bulbs.

The goal of these recommendations is to minimize energy consumption to foster sustainable practices. LED lighting uses the least amount of energy of any lighting currently available, and LED bulbs are available that can operate off of the 12V provided in the recommended ECon building solar system. Although LED lighting is also more expensive than incandescent or CFL bulbs, LED lights have a significantly longer life span, justifying the higher cost over time.

2. Remove the reptile heating lamp and replace with a heating rock.

A heat rock uses much less energy than any lamp, can be run through low power inverter operating off a 12V solar system, and is more energy efficient than a heat lamp.

3. Refrigerator

The original refrigerator at the ECon building was not designed for energy efficiency and would exhaust the energy supplied by the ECon building solar system. An energy efficient, mini refrigerator, such as the [SunDanzer DC Refrigerator DCR50](#), could be used for the required storage of animals or ecology related specimen. The size of the refrigerator is about two-thirds the size of the original Emmerson refrigerator used previously, and is designed to work on the energy constraints of a solar system, providing an energy-efficient solution for refrigeration. The SunDanzer DCR50 does not have a freezer compartment as the Emmerson does, but interviews with the ECon site staff suggests a freezer is not needed. The SunDanzer DCR50 operates with a compressor; however, there are also Peltier mini refrigerators available that provide solid-state refrigeration (more durable, longer lasting) as well as energy efficient operation. A refrigerator such as the SunDanzer DCR50 or an refrigerator equipped with Peltier technology is recommended.

4. Cooling Fan

A cooling fan for the ECon lodge is not technically required for any educational programs at the ECon lodge, but is rather a comfort device; however, providing a comfortable environment for the scouts and their instructors while working will help maintain concentration and productivity according to Maslow's Hierarchy of Needs. A suggested energy efficient cooling fan would be something along the lines of the [Fan-Tastic 01100WH Endless Breeze Stand alone Fan](#). The Fan-Tastic is designed for DC operation and energy efficiency, and should provide similar circulation to the previously used Holmes Blizzard.

5. 12V outlets

Most electronics and home appliances are designed to be connected to traditional wall outlets (two prong) with 120VAC and typical electronics are not always compatible with a 12V outlet. The easiest way make electronics compatible without question is to install 12V outlets, similar to the 12V outlet in a car, so 12V adapters can be used with typical electronics and appliances. In the case that the appliance or other device needs 120VAC to work properly, the 12V outlet is most appropriate, because you can then plug in phone chargers, other 12V appliances, and an inverter to run low power AC devices (such as the heat rock).

6. Additional Solar Panels

This report plans to install two solar panels for the ECon building solar system, but over time, additional panels and an extra battery storage would help supply the energy needed for other electronics, such as fish tank pumps or additional lighting. Without building any addition, the planned solar panel frame for the ECon building solar system could accommodate one more identical solar panel. Adding another panel and battery would increase the energy available to use at the ECon building, and provide some convenience beyond the current needs of the ECon building.

5.5 Mid-Term Recommendations

7. Add Lighting/Motion Sensors

Though not discussed in the results, there are other devices we are recommending for future installation to increase efficiency and device autonomy. One item for future installation would be motion sensors used in conjunction with light sensors. The lighting sensors would be used to automatically turn the lights on and off as a switch does, but only when the light in the room is sensed as inadequate and only when somebody is detected to have moved inside the building. The current planned solar installation at the ECon building has a timer that turns the lights on and off at certain times, creating a rigid and perhaps inconvenient schedule for lighting. The lighting timer was planned to predict the energy spent on lighting on a daily basis; however, the lighting needs of the ECon building as discussed with the ECon site staff is intermittent and not necessarily during the times the timer would be set for, thus creating waste. The sensor devices

would eliminate the possibility of leaving the lights on and depleting the batteries, and can operate 24 hours using little energy without the inconvenience of a rigid schedule.

8. Add Timed Switches for the Lighting

Another solution to lighting control that is perhaps simpler than motion activated lighting would be to install a push-button switch that times the light-on period. The timer switch would be pushed, the lights would turn on, and the timer would keep them on for 15, 20, 30, or however many minutes would be appropriate. The suggested time would be 15 to 20 minutes, because the timer would keep the lights on when not needed in certain circumstances, draining the stored energy in the solar system. The timer switches would replace the typical flip-switch, and would be an all-in-one device with the timer built in. One drawback of this method of lighting energy control would be that anyone can push the button for light at any time, turning the lights on when not needed and using the stored solar system energy irresponsibly.

9. Electrical Energy Informational Display

This project had done the work to make the ECon site sustainable in terms of electrical energy, only designing electrical energy use in correlation with the estimated energy generated by the solar panels. In the event that electrical energy use exceeds the energy produced by the solar panels, the system is designed to cut power to all the devices to limit battery damage until the batteries have recharged to a certain level. A display panel connected to the batteries, the solar panels, and the output wire would display the amount of energy provided by the panels, the charge of the batteries, and the energy used in the ECon building, which would be useful in both monitoring energy use and educating scouts about energy distribution. It is recommended that this panel should be wall mounted in the main room of the ECon building, away from the charge controller and batteries, and in plain sight to anyone in the room.

5.6 Long-Term Recommendations

10. Remove Additional Trees

The tree coverage all around the ECon site was extensive, which limits the potential to generate solar energy. This recommendation, though brief, may be the most important regarding the future of the ECon site to be electrically self-sustainable. Trees must be removed from the ECon site and surrounding perimeter to allow direct sunlight to be provided to future solar panel sites.

Responsible deforestation requires focused planning, and removing trees that do not need to be removed, such as clearcutting, destroys natural habitat and may have unintended consequences. To decide which trees to cut down, first decide where the direct sunlight is needed and for how many hours a day. The next step would be to take a device, such as the Solar Pathfinder, and collect data on the targeted site. Using this data, make an educated decision as to which trees being felled would provide the required sunlight to the area. Deforestation includes heavy equipment that may be dangerous to the unskilled, so it is suggested that knowledgeable professionals facilitate the physical tree removal.

11. Measure Solar Energy Potential Using Sun Mapping

Future solar system installation depends on solar panel placement and direct sunlight available at the site in question. Using a sun-mapping device such as the Solar Pathfinder, visit all the sites being considered for future solar panel installation and record the available sun at these sites. The data collected at the sites will be instrumental in planning for future effective solar systems by helping select a location that can provide the needed sunlight, or by helping to decide which trees or other obstacles need to be removed to help provide the needed sunlight.

12. Study the Use of Energy on TVSR-West Buildings

To prepare for future solar system installation on the TVSR-west buildings, it would be useful to start recording energy use for these buildings throughout the year. This would include recording when the building is in use, the electronics or electrical energy used while in use, and creating an educated estimate for electrical energy consumption through electronic device energy ratings for an entire year. The information gathered through recording energy use would be helpful in predicting the requirements for the individual solar system installations on each building considered, by deciding how many panels are needed, how many batteries are needed for storage, and what kind of improvements can be made by eliminating or replacing energy-hungry devices.

5.7 Future Project Recommendations

13. Vernal Pool Development Study

One project includes the study and development of the vernal pool in the ECon site. Studying the water, soil, and wildlife of the area surrounding the vernal pool, this site could be preserved and better observed for educational use. Proposed during the spring when the vernal pool would be both created and active, the study would include gathering water samples, soil samples, and notes on the kind of life that thrive there. The information gathered would then provide valuable learning material to visiting scouts during the summer camp off-season, so that when visiting, the scouts and their leaders may use the vernal pool as an educational asset. Providing an educational scouting experience would include further augmenting requirement completion at the ECon site, making the ECon site more useful to the BSA.

In addition to an ecological study of the ECon sites' vernal pool, the proposed project may also suggest a viewing platform that may be used and constructed without interfering with the vernal pool. Suggesting a viewing platform would entail documenting the size and behavior of the vernal pool, and deciding the type of platform that would be appropriate without disturbing the seasonal habitat, while increasing the educational experience.

14. New Ecology Conservation Building and Program Expansion Study

Another suggested project would be to initiate building designs dedicated to the needs of a new ecology conservation building. This new building location may take this papers suggestion or

another location, such as in close proximity to the vernal pool and the pools' proposed observation deck. The new building should also be designed with off-grid solar power as the energy source, as the site will have no power. The design of the proposed ecology conservation building will accommodate the needs of the BSA ecology program, allowing the current ECon building to be used solely as an energy sustainability building. Using the information from the proposed vernal pool project, designing a new ecology conservation building should consider connecting the vernal pool viewing platform to the new building, using the pool to enhance the BSA ecology program.

15. Advanced Solar System Design and System Expansion Study

The purpose of this project would be to limit human interaction with the ECon building solar system with the intent of creating the most efficient use of energy possible. This project would include automatic operation of all the electronics, including automatic light switching, appliance control, and electrical monitoring of devices when human interaction is absolutely necessary. As an example, automatic lights and appliances would entail sensors and switches, but electrical monitoring would include a warning alarm if the mini fridge is open too long, or displaying battery energy storage percent levels on a monitor panel. This project may also include a redundancy plan for a case where the autonomy electronics are broken or malfunctioning, including manual switches.

16. Additional Solar Panel and ECon Electrical Output Study

Another suggested project would be closely related to this project, by installing another three solar panels and designing the power distribution throughout the ECon building. With double the energy available, several other possibilities to use the energy may be proposed. This project may include suggesting a separate 24V line distributed throughout the ECon building to power various electronics. The project could focus on the power electronics involved to meet future electrical energy needs and goals of the ECon building, with an emphasis on energy efficiency. The project could also include planning for outdoor lighting at the ECon building, which the ECon staff requested for further development of the programming at the ECon site.

To help conceive the sum of all the changes presented in our recommendation section, Figure 72 below represents our version of the layout of the envisioned sustainability center.

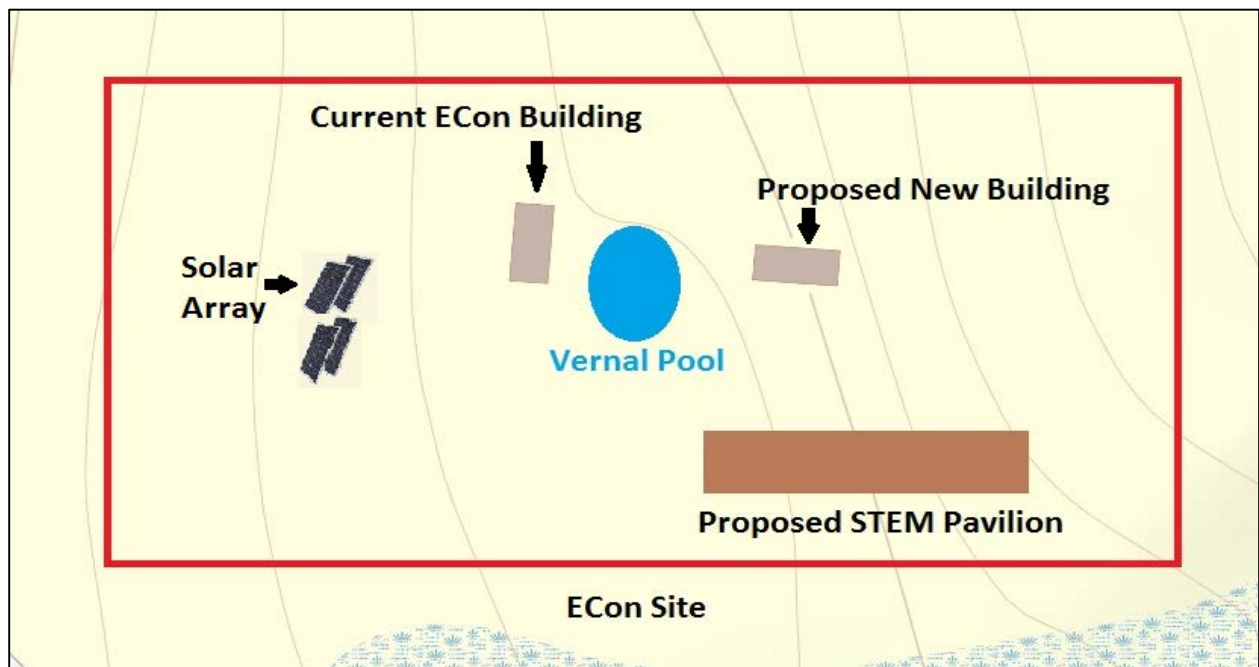

Figure 72 - Envisioned STEM/sustainability center

5.8 Project Summary

This project can be summarized as having planned four goals: assessing electrical energy needs at the ECon building, planning for a solar system installation at ECon to meet those energy needs, planning for sustainability and STEM education for scouts using the new solar system at ECon, and providing a vision for the ECon site as a center for STEM and sustainability. It is heartening to have seen some progress made to fulfill these goals at the ECon site. We look forward to future participation with the implementation of the ideas set forth in this project report.

Citations

- [1 U. E. I. Administration, "TOTAL ENERGY (graph)," U.S. Department of Energy, 1 January 2012. [Online]. Available: <http://www.eia.gov/beta/MER/index.cfm?tbl=T01.01#/?f=A&start=200001>. [Accessed 19 May 2015].
- [2 U. E. I. Administration, "TODAY IN ENERGY," U.S. Department of Energy, 3 July 2013. [Online]. Available: <http://www.eia.gov/todayinenergy/detail.cfm?id=11951>. [Accessed 1 June 2015].
- [3 U. E. I. Administration, "TOTAL ENERGY," U.S. Department of Energy, 27 September 2012. [Online]. Available: <http://www.eia.gov/totalenergy/data/annual/perspectives.cfm>. [Accessed 1 June 2015].
- [4 U. E. I. Administration, "Primary Energy Consumption by Source and Sector, 2014," March 2015. [Online]. Available: http://www.eia.gov/totalenergy/data/monthly/pdf/flow/css_2014_energy.pdf. [Accessed 4 June 2015].
- [5 U. E. I. Administration, "DATA: Monthly Energy Review," 22 May 2015. [Online]. Available: <http://www.eia.gov/totalenergy/data/monthly/>. [Accessed 4 June 2015].
- [6 R. Engelman, "Beyond Sustainability," in *Is Sustainability Still Possible?*, Washington, DC: Worldwatch Institute, 2013, pp. 3 - 17.
- [7 E. (figure), "Photovoltaics," 2014. [Online]. Available: <http://www.engineering.com/SustainableEngineering/RenewableEnergyEngineering/SolarEnergyEngineering/Photovoltaics/tabid/3890/Default.aspx>. [Accessed 1 June 2015].
- [8 J. Hotchkiss, Interviewee, *Scout Executive/CEO, BSA-Mohegan Council*. [Interview]. 18 May 2015.
- [9 B. S. o. America, Scout, *The Boy Scout Handbook: A Guide To Adventure, A Guide Book For Life*, Irving, TX: Self Published, 2014.
- [1 B. S. o. A. Mohegan Council, "Treasure Valley Scout Reservation," 2014. [Online]. Available: <http://www.mohegancouncilbsa.org/treasure-valley-scout-reservation/>. [Accessed 4 June 2015].
- [1 J. Correia, *ECon hand-drawn overhead*, Worcester, 2015.

- [1 S. Gregersen, Build Your Own Low-Budget Solar Power System, Lexington, KY: Self
2] Published, 2015.
- [1 W. Peter, "www.anthroposophie.net," Anthroposophie , [Online]. Available:
3] http://www.anthroposophie.net/bibliothek/nawi/physik/volta/bib_volta.htm. [Accessed 22 6
2015].
- [1 P. U. Javeriana. [Online]. Available:
4] http://pioneros.puj.edu.co/biografias/edad_moderna/1750_1800/andre_marie_ampere.html.
[Accessed 22 6 2015].
- [1 R. Kaza, "University of Houston," [Online]. Available:
5] <http://www.uh.edu/engines/epi2869.htm>. [Accessed 22 6 2015].
- [1 G. Boyle, Renewable Energy - Power for a Sustainable Future, Oxford: Oxford University
6] Press, 2004.
- [1 "Randolph College," [Online]. Available:
7] <http://faculty.randolphcollege.edu/tmichalik/images/Joule2.jpg>. [Accessed 28 6 2015].
- [1 Alternative-energy.org, "Alternative Energy," [Online]. Available: [http://www.alternative-
8\] energy-news.info/images/technical/solar-power.jpg](http://www.alternative-8] energy-news.info/images/technical/solar-power.jpg). [Accessed 22 6 2015].
- [1 "The Green Home," [Online]. Available: [http://www.thegreenhome.co.uk/wp-
9\] content/uploads/2013/03/solar-thermal-panels.jpg](http://www.thegreenhome.co.uk/wp-9] content/uploads/2013/03/solar-thermal-panels.jpg). [Accessed 24 6 2015].
- [2 "The green home," [Online]. Available: [http://www.thegreenhome.co.uk/wp-
10\] content/uploads/2013/08/Solar-Thermal-Panels-or-Evacuated-Tubes-500x385.jpg](http://www.thegreenhome.co.uk/wp-10] content/uploads/2013/08/Solar-Thermal-Panels-or-Evacuated-Tubes-500x385.jpg). [Accessed
2015 6 7].
- [2 "Solar knowledge," Everlight home, [Online]. Available: [http://www.everlight-
1\] solar.com/en/home3.html](http://www.everlight-1] solar.com/en/home3.html). [Accessed 28 6 2015].
- [2 "Controller tracks sun for PV Panels," Solar Power World Online, [Online]. Available:
2] <http://www.solarpowerworldonline.com/2010/08/controller-tracks-the-sun-for-pv-panels/>.
[Accessed 28 6 2015].
- [2 "Feg Structural," [Online]. Available:
3] <http://www.fegstructural.com/announcements/20110707>. [Accessed 31 7 2015].
- [2 Thesolarplanner.com, "The Solar Planner," [Online]. Available:
4] http://www.thesolarplanner.com/array_placement.html. [Accessed 24 6 2015].
- [2 I. R. Service, "Exemption Requirements - 501(c)(3) Organizations," IRS, 08 January 2015.
5] [Online]. Available: <http://www.irs.gov/Charities-&-Non-Profits/Charitable->

Organizations/Exemption-Requirements-Section-501(c)(3)-Organizations. [Accessed 22 June 2015].

- [2 A. Field, "This Platform Helps Nonprofits Pay For Solar Power," *Forbes*, 18 2014.
- 6] [Online]. Available: <http://www.forbes.com/sites/annefield/2014/01/18/this-platform-helps-nonprofits-pay-for-solar-power/>. [Accessed 30 June 2015].
- [2 U. E. P. Agency, "Green Building Funding Opportunities," U.S. Environmental Protection
- 7] Agency, 9 October 2014. [Online]. Available: <http://www.epa.gov/greenbuilding/tools/funding.htm>. [Accessed 30 June 2015].
- [2 C. o. Massachusetts, "About the Solar Carve-Out II program," Executive Office of Energy
- 8] and Environmental Affairs, 2015. [Online]. Available: <http://www.mass.gov/eea/energy-utilities-clean-tech/renewable-energy/solar/rps-solar-carve-out-2/about-solar-carve-out-ii.html>. [Accessed 22 June 2015].
- [2 REC-Admin, "Learn About Three New Solar Financing Models for Non-Profits Wanting To
- 9] Go Solar," *REC Solar*, 22 April 2014. [Online]. Available: <http://blog.recsolar.com/2014/04/learn-about-three-new-finance-models-for-non-profits-wanting-to-go-solar/>. [Accessed 30 June 2015].
- [3 B. S. o. America, "Advancement Defined," Boy Scouts of America, 2015. [Online].
- 0] Available: <http://www.scouting.org/Home/GuideToAdvancement/AdvancementDefined.aspx>. [Accessed 2 June 2015].
- [3 B. S. o. America, 2015 Boy Scout Requirements, Irving, TX: Self Published, 2015.
- 1]
- [3 B. S. o. A. N. N. J. Council, "Internet Advancement," Boy Scouts of America, 2015.
- 2] [Online]. Available: <http://www.nnjbsa.org/boy-scouts/advancement/59120>. [Accessed 11 June 2015].
- [3 B. S. o. America, "Engineering," Boy Scouts of America, 2015. [Online]. Available:
- 3] <http://www.scouting.org/scoutsource/BoyScouts/AdvancementandAwards/MeritBadges/mb-ENGI.aspx>. [Accessed 11 June 2015].
- [3 B. S. o. America, "Earning a Hornaday Medal," BSA, 2015. [Online]. Available:
- 4] <http://www.scouting.org/scoutsource/Awards/HornadayAwards/Earn.aspx>. [Accessed 3 June 2015].

- [3 B. S. o. America, "Eagle Palms*," Boy Scouts of America, 2015. [Online]. Available:
5] <http://www.scouting.org/scoutsource/BoyScouts/AdvancementandAwards/eaglepalm.aspx>.
[Accessed 11 June 2015].
- [3 B. S. o. America, "What is STEM and Nova?," Boy Scouts of America, 2015. [Online].
6] Available: <http://www.scouting.org/stem/AboutSTEM.aspx>. [Accessed 2 June 2015].
- [3 U. D. o. Education, "Science, Technology, Engineering and Math: Education for Global
7] Leadership," U.S. Department of Education, 2015. [Online]. Available:
<http://www.ed.gov/stem>. [Accessed 30 July 2015].
- [3 S. E. Coalition, "Home," STEM Education Coalition, 2015. [Online]. Available:
8] <http://www.stemedcoalition.org/>. [Accessed 30 July 2015].
- [3 N. S. Foundation, "What does the S&E job market look like for U.S. graduates?," National
9] Science Foundation, 2015. [Online]. Available:
<https://www.nsf.gov/nsb/sei/edTool/data/workforce-03.html>. [Accessed 30 July 2015].
- [4 R. N. Charette, "The STEM Crisis Is a Myth," IEEE , 30 August 2013. [Online]. Available:
0] <http://spectrum.ieee.org/at-work/education/the-stem-crisis-is-a-myth#>. [Accessed 30 July
2015].
- [4 S. McLeod, "Maslow's Hierarchy of Needs," Simply Psychology, 2007. [Online]. Available:
1] [http://www.ouchihs.org/apps/download/2/NghLRUHA09ycRFi190Zws5youGeihn81UYVG
pHLCukjXEs1.pdf/Maslow's%20Hierarchy%20of%20Needs.pdf](http://www.ouchihs.org/apps/download/2/NghLRUHA09ycRFi190Zws5youGeihn81UYVGpHLCukjXEs1.pdf/Maslow's%20Hierarchy%20of%20Needs.pdf). [Accessed 9 June 2015].
- [4 H. Villarica, "Maslow 2.0: A New and Improved Recipe for Happiness," 17 August 2011.
2] [Online]. Available: [http://www.theatlantic.com/health/archive/2011/08/maslow-20-a-new-
and-improved-recipe-for-happiness/243486/](http://www.theatlantic.com/health/archive/2011/08/maslow-20-a-new-and-improved-recipe-for-happiness/243486/). [Accessed 9 June 2015].
- [4 A. S. University, "Maslow's pyramid gets a much needed renovation," Arizona State
3] University, 18 August 2010. [Online]. Available:
https://asunews.asu.edu/20100819_maslowspyramid. [Accessed 9 June 2015].
- [4 U. D. o. T. F. A. Administration, Aviation Instructor's Handbook, Washington, DC: United
4] States Government Printing Office, 2008.
- [4 R. D. B. J. Joy James, "Children's Role in Meaning Making Through Their Participation in
5] an Environmental Education Program," *The Journal of Environmental Education*, vol. 39,
no. 4, pp. 44-59, 2008.
- [4 D. R. C. a. J. S. e. Boud, Peer learning in higher education: Learning from and with each
6] other, London: Kogan Page Limited, 2014.

- [4 K. J. Topping, "Trends in Peer Learning," *Educational Psychology: An International Journal of Experimental Educational Psychology*, vol. 25, no. 6, pp. 631 - 645, 2005.
- [4 [Online]. Available: http://energy.gov/sites/prod/files/lights_cfls_hires_0.jpg. [Accessed 24 7 8] 2015].
- [4 E. M. U. R. Fawwaz T. Ulaby, *Fundamentals of Applied Electromagnetics*, Salt Lake, Utah: 9] Prentice Hall, 2010.
- [5 A. Questions, "Animalquestions.org," animal questions, 20 1 2015. [Online]. Available: 0] <http://animalquestions.org/reptiles/snakes/are-snakes-warm-blooded-or-cold-blooded/>. [Accessed 10 8 2015].
- [5 [Online]. Available: <http://sunshineworks.com/sundanzer-dc-refrigerator-50l.htm> . [Accessed 1] 24 7 2015].
- [5 "Fantastic Vent," Fantastic Vent, [Online]. Available: <http://www.fantasticvent.com/fantastic-vent-s-retail-stand-alone-fans.html>. [Accessed 24 7 2015].
- [5 M. W. Earley, 2014 NFPA 70: National Electrical Code (NEC), National Fire Protection 3] Association, 2014.
- [5 B. S. o. America, "Electricity," BSA, 2015. [Online]. Available: 4] <http://www.scouting.org/scoutsource/BoyScouts/AdvancementandAwards/MeritBadges/mb-ELEC.aspx>. [Accessed 31 July 2015].
- [5 B. S. o. America, "Electronics," BSA, 2015. [Online]. Available: 5] <http://www.scouting.org/Home/BoyScouts/AdvancementandAwards/MeritBadges/mb-ELET.aspx>. [Accessed 31 July 2015].
- [5 B. S. o. America, "Energy," BSA, 2015. [Online]. Available: 6] <http://www.scouting.org/scoutsource/BoyScouts/AdvancementandAwards/MeritBadges/mb-ENER.aspx>. [Accessed 31 July 2015].
- [5 B. S. o. America, "Green to Deep Green," BSA, 2015. [Online]. Available: 7] <http://www.greentodeepgreen.org/index.php#block2>. [Accessed 31 July 2015].
- [5 B. S. o. America, "STEM/Nova Cub Scout," BSA, 2015. [Online]. Available: 8] <http://www.scouting.org/stem/Awards/CubScout.aspx>. [Accessed 31 July 2015].
- [5 B. S. o. America, "STEM/Nova Boy Scouts," BSA, 2015. [Online]. Available: 9] <http://www.scouting.org/stem/Awards/BoyScouts.aspx>. [Accessed 31 July 2015].
- [6 M. Town of Paxton, "MuniMapper: Paxton, MA," Town of Paxton Web Site, 2015. [Online]. 0] Available: http://maps.massgis.state.ma.us/map_ol/paxton.php . [Accessed 5 August 2015].

- [6 Google, "Google Maps Satellite," Google, 2015. [Online]. Available:
1] <https://www.google.com/maps/@42.3214754,-71.9919469,382m/data=!3m1!1e3!5m1!1e4> .
[Accessed 5 August 2015].
- [6 C. Kinkaid, Solar PV Off-Grid Power: How to Build Solar PV Energy Systems for Stand
2] Alone LED Lighting, Cameras, Electronics, and Remote Communication Power Systems,
Portland, Oregon: Solardyne, LLC, 2014.
- [6 D. J. MacKay, Sustainable Energy - without the hot air, Cambridge: UIT Cambridge Ltd.,
3] 2009.
- [6 P. Hurley, Solar II: How to Design, Build and Set Up Photovoltaic Components and Solar
4] Electric Systems, Wheelock, VT: Wheelock Mountain Publications, 2012.
- [6 B. Gehrman, "wikipedia.org," [Online]. Available:
5] https://en.wikipedia.org/wiki/Georg_Simon_Ohm#/media/File:Georg_Simon_Ohm3.jpg.
[Accessed 27 6 2015].

Appendix A

The Project Contact List contains the persons instrumental in the outcomes of this project.

Project Contact List		
Name	Position	Contact Info
Martha Cyr	K-12 STEM expert, WPI faculty	mcyr@wpi.edu
Jeff Hotchkiss	Mohegan Council CEO	jeff.hotchkiss@scouting.org
Ray Griffin	BSA solar expert	ray.j.griffin@gmail.com
Matt McLaughlin	full-time TVSR ranger	matt.mclaughlin@scouting.org
Annika McRae	ECon site summer camp program director	annika.mcrae@gmail.com
Tom Chamberland	TVSR staff	tchamberland301@gmail.com
Jim Dunn	Solar equipment supporter and donator	jpdunn1@charter.net , www.FutureSolarSystems.com
Fred Looft	Project Advisor, WPI faculty	fjlooft@wpi.edu

Executive Summary

Project Goals

5. Assess the electrical energy needs of the Environmental Conservation (ECon) building,
6. Develop a plan using solar energy to meet the ECon building needs,
7. Develop a plan for sustainability studies and solar energy generation to be incorporated into existing scouting educational programs and badges, and
8. Develop a vision for the future use of the ECon site as a center for Science, Technology, Engineering, Math (STEM) and sustainability studies.

The Project Site

- Treasure Valley Scout Reservation, Mohegan Council, Massachusetts
- Includes the towns of Paxton, Rutland, Oakham, and Spencer
- ECon is on the East side of camp

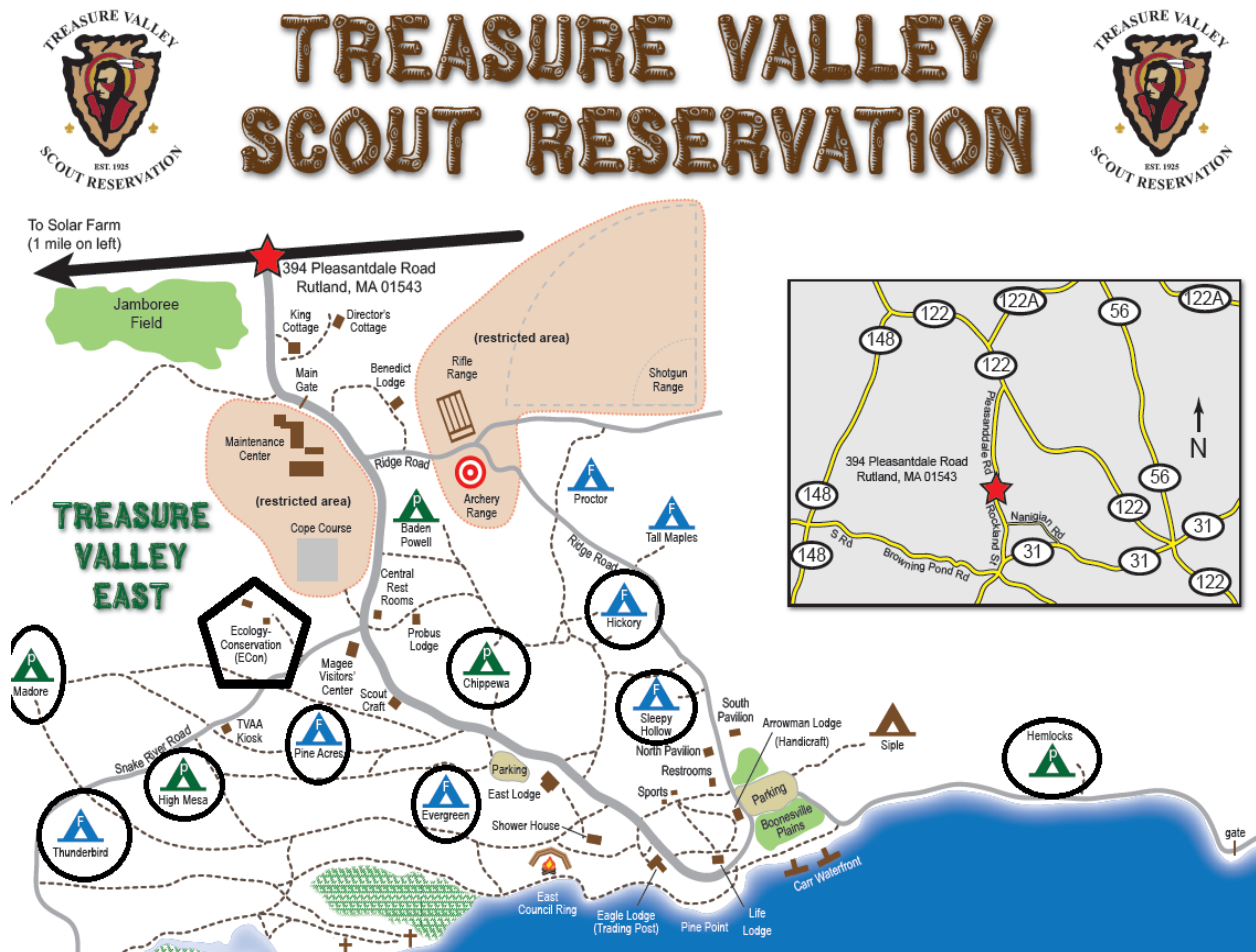

Figure 73

The map above in Figure 1 is the East side of camp only, showing the Boy Scout camp sites and activities. Solar systems have been installed on this side only, and are complete at the circled sites. The circled sites are camp sites with solar lighting provided in the latrines and dining pavilions. The ECon site is located in the pentagon, and is the target of our projects' solar study, providing for all the electrical energy needs at the ECon building.

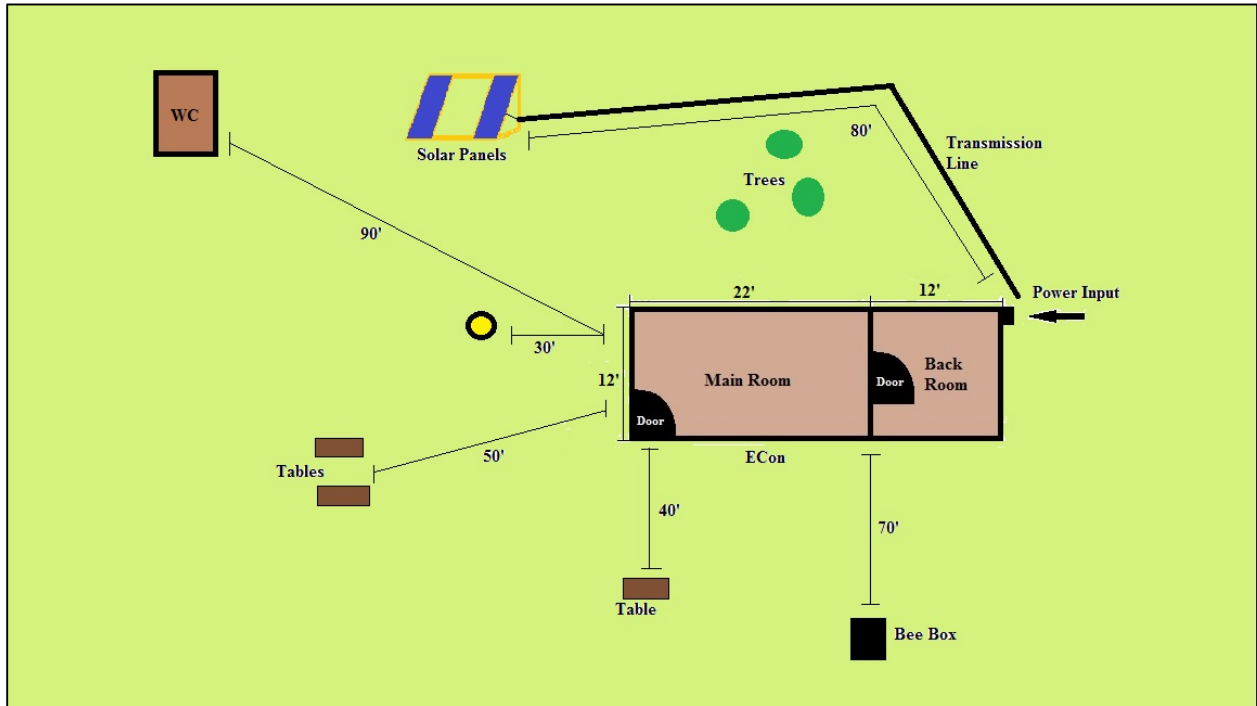

Figure 74

Figure 2 shows a descriptive map of the ECon building and surrounding area. The building is shown to have two rooms, a main room for ecology conservation education, and the back room for storage. The proposed solar panel placement can be seen with a suggested transmission line path to the back of the building. The proposed installation electrical equipment is suggested to be placed out of the way in the back room, near to where the old electric utility circuit breaker was located. Other features of the ECon site in Figure 2 are picnic tables, a latrine, a fire pit, and a bee box.

Solar Electrical Energy Generation

- Renewable, no emissions
- Enables self-regulated, self-maintained energy generation
- Uses semi-conductor science to turn light energy into electrical energy
- Off-Grid solar generation was recommended for ECon, regulating energy through batteries

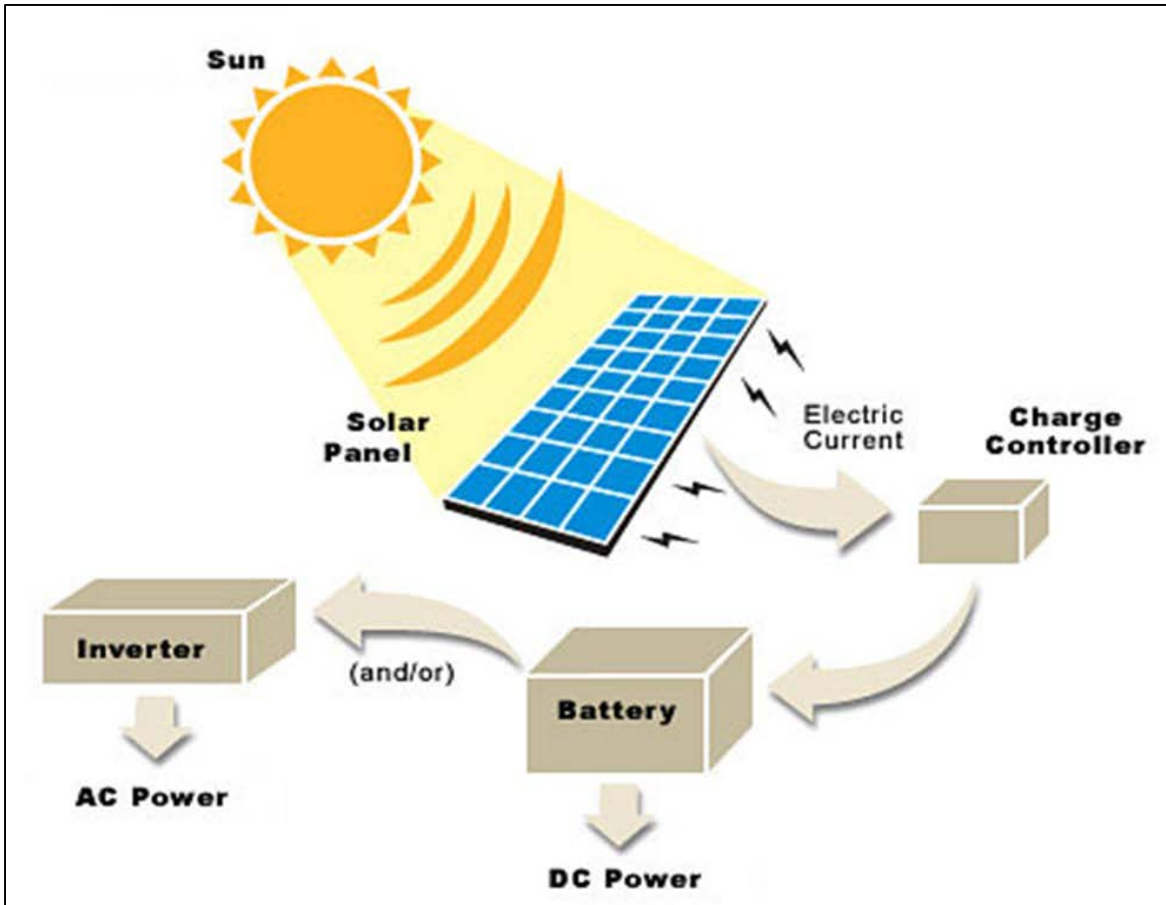

Figure 75

Figure 3 illustrates a simple example of off-grid solar energy flow from the sun to the power output. The sunlight is captured and turned to electrical energy by the solar panel, which then is transmitted to the charge controller. The charge controller is the main junction of the whole solar system, controlling voltage and current flow to the batteries, and controlling the output voltage. The batteries provide the energy for the devices connected to the output in DC power; however, an inverter may be connected to the batteries to provide for AC-powered devices, such as common household appliances.

Scouting Education through Advancement Requirements

- Merit Badges (MB) are the main advancement in scouting
- A few MB can be taught through the planned solar system at ECon
- NOVA advancement requirements may also be met through the planned solar system at ECon
- The requirements that may be met for each MB and the NOVA program are described with suggested methods of completion

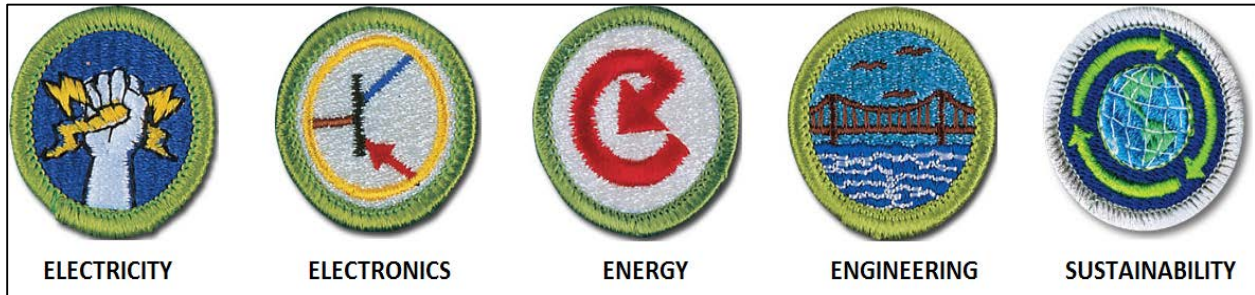

Figure 76

Figure 4 shows the merit badges with requirements that may be worked on with the help of the planned solar system at the ECon building, and other various campsites. Planning to have the solar panels installed on the ground will provide for an interactive display that will help with STEM/sustainability education in scouting. The Sustainability merit badge is the only merit badge shown here to be considered required for Eagle rank.

Electrical Needs of the ECon Building

- Through investigation, the building needs lighting, animal habitat support, refrigeration, and ventilation.
- The ecology conservation program currently uses the site for their needs.
- Solar energy is renewable, but not unlimited; therefore, electronics must be carefully selected to run efficiently off of the off-grid solar system.

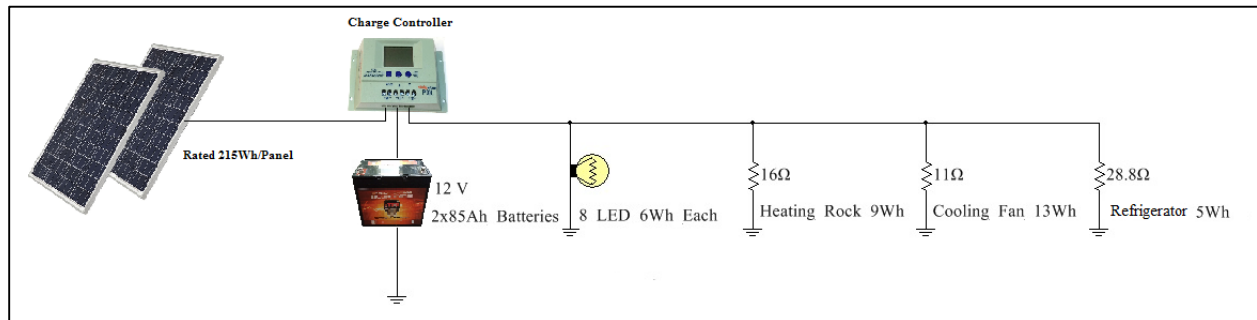

Figure 77

Figure 5 displays a one-line diagram of the proposed solar system at the ECon building with the estimated electrical load of energy saving devices. The one-line diagram is a simplified version of a proper electrical analysis of the building, but creates an accurate and easy to understand concept of the electrical workings of the proposed solar system.

Energy Needs with NEW Electronics					
	Hrs Operating/day				
# of Panels		1	2	3	4
Watt-Hr	4	400	800	1200	1600
LED Lighting 8x - 48W	4	✓	✓	✓	✓
Heat Rock - 9W	12	✓	✓	✓	✓
Mini Fridge - 5W(tested)	24		✓	✓	✓
Cooling Fan - 27W	8		✓	✓	✓
TOTAL WATT-HR USED		300	634	634	634
*Panel power is derated 50% from 215W to 100W, for inconsistent sun scenarios (cloud cover, rain, etc.)					

Figure 78

Figure 6 is an electrical energy analysis of the proposed solar system for the ECon building with energy-saving devices based on the needs of the ECon building. The highlighted column shows that with the proposed installation of two solar panels, the electrical energy demands of the ECon building may be met. It can be seen that with two solar panels, 800 Watt-Hours can be expected to be generated in four hours of full sun, and generating a marginal electrical energy surplus after providing the 634 Watt-Hours needed to run the devices listed.

ECon Site Considerations or Restrictions

- ECon site is a heavily wooded area, restricting direct sunlight to the ground level
- Vernal pool area takes away development opportunity from the ECon site, but may also serve as an area for ecology conservation study.



Figure 79

Figure 7 shows a picture taken from one side of the ECon site looking down to the other side, and showing that the amount of direct sunlight during the middle of the day is at a minimum. The area in the back of the picture is relatively well-lit, and is the proposed site for the ECon building solar panels. The well-lit part of the ECon site has been created by removing trees specifically targeted with sun-tracking equipment.

Project Recommendations

The following suggestions were recommended for our project to meet the energy demands of the ECon building.

- Replace lighting with LED bulbs
- Replace heating lamp with heating rock
- Upgrade to energy saving refrigerator, possibly DC or Peltier
- Replace the cooling fan with energy saver cooling fan
- 12V outlets in the ECon building
- Additional solar panel for the ECon building

Future Project Recommendations

To fulfill the vision of a STEM/sustainability center, the following is recommended to continue the work done by our project.

1. Mid-Term
 - Add sensors for the lighting
 - Add timed-switches for the lighting

- Electrical activity display for ECon building
2. Long-Term
 - ECon site strategic tree removal
 - Map solar capabilities around the ECon site
 - Study the energy used at buildings on the West side of camp on an annual scale
 3. Future Projects
 - Vernal pool study and development
 - A new ecology conservation building
 - Solar system electrical upgrades for automated energy efficiency
 - Add solar panels and more electrical output to the ECon building

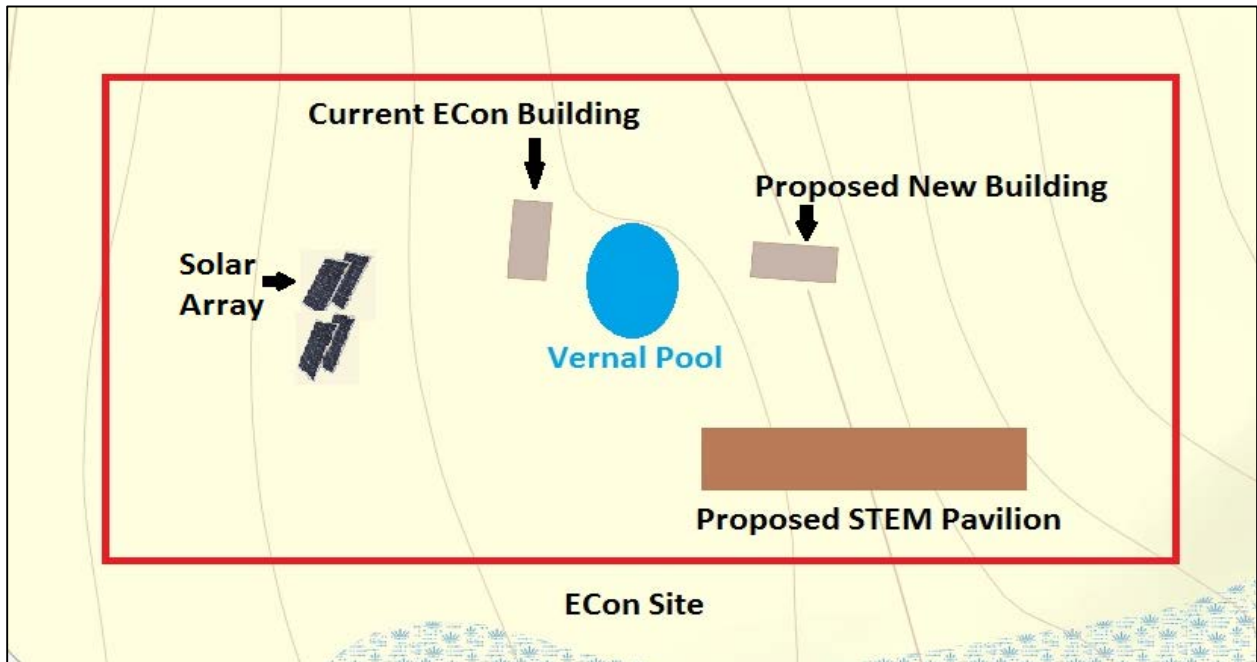

Figure 80

Figure 8 is a representation of the future layout of the ECon site envisioned in our project. The proposed new building would be dedicated to ecology conservation and using the vernal pool as part of its' program, while the current ECon building would be dedicated to electrical energy sustainability/conservation. The solar panel array location is shown next to the current ECon building, recommending that more panels be installed in the future. The proposed STEM pavilion location is also shown, where students may learn STEM concepts outlined in the NOVA program and create STEM projects.