

# Design of a Fibrin Microthread Bundling Device

A Major Qualifying Project Report

Submitted to the Faculty of

Worcester Polytechnic Institute

In partial fulfillment of the requirements for the

Degree of Bachelor of Science

By

---

Dennis Chen

---

Naim Habib

---

Catherine Knott

---

Corey Mjeika

July 2, 2013

Approved by:

---

Professor Glenn Gaudette, Advisor

## Table of Contents

<b>Acknowledgements .....</b>	<b>7</b>
<b>Abstract .....</b>	<b>8</b>
<b>Chapter 1: Introduction .....</b>	<b>9</b>
<b>Chapter 2: Background .....</b>	<b>10</b>
<b>2.1 Mesenchymal Stem Cells .....</b>	<b>10</b>
2.1.1 MSC Regenerative Applications .....	11
<b>2.2 Myocardial Infarction Treatments .....</b>	<b>12</b>
<b>2.3 Biological Value of Fibrin.....</b>	<b>13</b>
<b>2.4 Fibrin Microthread Production .....</b>	<b>14</b>
2.4.1 Fibrin Microthread Bundling Process .....	14
<b>2.5 Physical Properties of Fibrin Microthreads.....</b>	<b>14</b>
2.5.1 Mechanical Properties of Fibrin Microthreads.....	15
2.5.2 Cell Seedability of Fibrin Microthreads .....	15
2.5.3 Effects of Crosslinking on Fibrin Microthreads.....	15
<b>2.6 Suture Production .....</b>	<b>16</b>
<b>2.7 Current Thread and Rope Making Processes .....</b>	<b>17</b>
2.7.1 Braiding Machines .....	17
2.7.2 Maypole Braiding Technique .....	18
2.7.3 Marine Industry Techniques .....	19
<b>Chapter 3: Project Strategy.....</b>	<b>20</b>
<b>3.1 Initial Client Statement.....</b>	<b>20</b>
<b>3.2 Design Objectives and Constraints.....</b>	<b>20</b>
3.2.1 Initial Design Objectives.....	21
3.2.2 Qualitative Assessment of Objectives.....	21
3.2.3 Design Constraints.....	23
<b>3.3 Revised Client Statement.....</b>	<b>23</b>
<b>3.4 Design Functions and Specifications .....</b>	<b>24</b>
3.4.1 Functions.....	24
3.4.2 Design Specifications.....	25

<b>Chapter 4: Alternative Designs</b> .....	<b>26</b>
<b>4.1 Needs Analysis</b> .....	<b>26</b>
Systemic Needs .....	27
Systemic Wants.....	28
<b>4.2 Conceptual Designs</b> .....	<b>30</b>
4.2.1 Bundling Through Twisting.....	30
4.2.2 Bundling Through Braiding.....	32
<b>4.3 Preliminary Designs</b> .....	<b>33</b>
4.3.1 Maypole Single and Double Braid Design – Preliminary Design 1 .....	34
4.3.2 Jelly Fish Design – Preliminary Design 2.....	34
4.3.3 Screw and Plate Design – Preliminary Design .....	35
4.3.4 Simple Twist Design – Preliminary Design 4.....	36
<b>4.4 Design Modeling</b> .....	<b>37</b>
4.4.1 Maypole Braiding Technique Modeling.....	37
4.4.2 Design Concept Modeling .....	37
<b>4.5 Feasibility Study and Preliminary Experiments</b> .....	<b>38</b>
4.5.1 Mechanical Testing – Preliminary Experiment .....	38
<b>4.5 Preliminary Data</b> .....	<b>41</b>
4.5.1 Mechanical Testing Results.....	41
<b>Chapter 5: Design Verification</b> .....	<b>42</b>
<b>5.1 Mechanical Testing Results</b> .....	<b>42</b>
<b>5.2 Cell Seedability Testing Results</b> .....	<b>45</b>
<b>5.3 Consistency Testing Results</b> .....	<b>47</b>
<b>Chapter 6: Discussion</b> .....	<b>49</b>
<b>6.1 Bundle Mechanics Testing</b> .....	<b>49</b>
<b>6.2 Cell Seedability Testing</b> .....	<b>50</b>
<b>6.3 Consistency Testing</b> .....	<b>51</b>
<b>6.4 Impact Analysis</b> .....	<b>51</b>
6.4.1 Economic impact.....	51
6.4.2 Environmental Impacts.....	51
6.4.3 Societal Influence .....	52
6.4.4 Political Ramifications .....	52

6.4.5 Ethical Concerns.....	52
6.4.6 Health and Safety Issue .....	52
6.4.7 Manufacturability .....	53
6.4.8 Sustainability .....	53
<b>Chapter 7: Final Design and Validation .....</b>	<b>54</b>
<b>7.1 Machine Validation .....</b>	<b>55</b>
7.1.1 Thread Path.....	55
7.1.2 Lifting System.....	57
7.1.3 Guiding Mechanism.....	57
7.1.4 Hydration .....	58
<b>7.2 Bundle Validation.....</b>	<b>59</b>
7.2.1 Mechanical Analysis.....	59
7.2.2 Structural Analysis .....	59
<b>7.3 Final Design .....</b>	<b>60</b>
<b>Chapter 8: Conclusions and Recommendations .....</b>	<b>62</b>
<b>8.1 Recommendations.....</b>	<b>62</b>
<b>References .....</b>	<b>64</b>
<b>Appendices .....</b>	<b>67</b>
<b>Appendix A: Design Objectives Tree.....</b>	<b>67</b>
<b>Appendix B: Design Specifications .....</b>	<b>68</b>
<b>Appendix C: Instron Testing Protocol for Microthread Bundle .....</b>	<b>69</b>
<b>Appendix D: Cell Culturing and Media Production Protocols.....</b>	<b>73</b>
<b>Appendix E: Protocol for Seeding Fibrin thread bundles with hMSCs using Rotator .....</b>	<b>76</b>
<b>Appendix F: Staining Protocol.....</b>	<b>77</b>
<b>Appendix G: CyQUANT DNA Assay .....</b>	<b>78</b>
<b>Appendix H: Consistency testing protocol.....</b>	<b>82</b>
<b>Appendix I: Initial Prototype Images.....</b>	<b>83</b>
<b>Appendix J: Second Prototype Images.....</b>	<b>85</b>

## Table of Figures

Figure 1: Ant heads used as ancient sutures .....	16
Figure 2: Schematic diagram of circular braiding arrangement.....	18
Figure 3: Maypole Braiding Machine Gear and Sprocket Assembly.....	19
Figure 4: Maypole machine used in textile and rope industries.....	34
Figure 5: CAD model of Jelly Fish Design – Preliminary Design 2.....	35
Figure 6: CAD model of Screw and Plate Design – Preliminary Design 3 .....	36
Figure 7: CAD model of Simple Twist Design – Preliminary Design 4 .....	36
Figure 8: Left - Single yarn braid from Maypole technique. Right - double yarn braid from Maypole technique.....	37
Figure 9: Left - Cardboard model of Screw and Plate Design. Right - cardboard model of Simple Twist Design.....	38
Figure 10: Gateway's Instron Machine used for uniaxial mechanical testing.....	38
Figure 11: A sample image of taken of a microthread bundle used for mechanical testing.	39
Figure 12: A microthread bundle sample loaded into the custom grips used for uniaxial mechanical testing.....	39
Figure 13: The sample loaded into the Instron machine ready for testing.....	40
Figure 14: The calculated mean diameter for each sample and the mean and standard deviation for VitaThreads and prototype produced bundle samples.....	43
Figure 15: The calculated yield strength (YS) for each sample and the mean and standard deviation for VitaThreads and prototype produced bundle samples.....	44
Figure 16: The calculated ultimate tensile strength (UTS) for each sample and the mean and standard deviation for VitaThreads and prototype produced bundle samples.....	44
Figure 17: The calculated modulus of elasticity ( $E$ ) for each sample and the mean and standard deviation for VitaThreads and prototype produced bundle samples.....	45
Figure 18: VitaThreads bundle sample with Phalloidin and Hoescht stain at 5x magnification.....	46
Figure 19: A sample bundle being imaged at 5x under the microscope for twist consistency testing.....	47

Figure 20: Results of the consistency testing showing number of twist per cm for prototype produced bundles.....	48
Figure 21: The design team's Gantt chart for the project.....	55
Figure 22: The final design for the threading discs. ....	56
Figure 23: CAD model of the final design of the bundling device.....	61

## Table of Tables

Table 1: Averaged objectives ranking from outside opinions .....	22
Table 2: Team's objectives ranking.....	22
Table 3: Initial Design Constraints .....	23
Table 4: Needs and wants for the system.....	27
Table 5: System Design Matrix.....	29
Table 6: Calculated results of preliminary mechanical testing on microthread bundles. ....	41
Table 7: The mean and standard deviation for the two sample sets for all of the measured and calculate mechanical and physical properties.....	43
Table 8: Average number of cell on sutures per cm for prototype and VitaThreads samples. .....	46
Table 9: Results of different threading discs testing.....	56
Table 10: Results of different lifting system testing.....	57
Table 11: Results of different guiding mechanism testing.....	58
Table 12: Results of different hydration method testing. ....	58

## Acknowledgements

The team would like to acknowledge the following for their assistance and support in the lab and expertise in their respective fields:

### **Department of Biomedical Engineering:**

Professor Glenn Gaudette

Professor Sakthikumar Ambady

John Favreau, Ph. D. Candidate

Katrina Hansen, Ph. D. Candidate

Lisa Wall, Lab Manager

### **VitaThreads:**

Adam Collette, President



## Abstract

Fibrin microthreads are a biological material being examined for use in a targeted cell delivery system, but sutures created from the threads exhibit a variance in their mechanical properties. A mechanized and standardized fibrin microthread bundling device was designed and constructed to achieve the goal of producing consistent and reproducible microthread bundles. This was achieved by a rotating set of disks which combined the threads through a simple twist mechanism. The resulting bundles were compared to hand-made bundles through mechanical properties and cell seedability, with additional prototype measurements for thread twist consistency. Hand-twisted samples were calculated to have a  $YS$ ,  $UTS$ , and  $E$  of  $0.390 \pm 0.190$ ,  $1.066 \pm 0.678$ , and  $0.405 \pm 0.168$  MPa, respectively. Prototype produced bundles were found to have a  $YS$ ,  $UTS$ , and  $E$  of  $0.196 \pm 0.050$ ,  $0.537 \pm 0.181$ , and  $0.269 \pm 0.158$  MPa respectively. Additional prototype twisted bundles were found to contain an average of  $1.65 \pm 0.5$  twists per cm. Average values for bundle mechanics were found to be lower for prototype produced bundles. Standard deviations were also lower though, suggesting more consistent bundle production.

## Chapter 1: Introduction

Fibrin microthreads are made from the crosslinking of fibrinogen and thrombin. Fibrin is a natural provisional matrix for cell attachment and migration during wound healing and has been used in the form of hydrogels and microthreads for cell delivery to target areas. This can lead to the restoration of skeletal muscle defects, as fibrin microthreads have been shown to increase healing outcome for a variety of wound types (Page et al, 2011). Fibrin microthreads have also been shown to support fibroblast attachment, proliferation, and alignment, suggesting that they represent a viable biomaterial in tissue regeneration (Cornwell and Pins, 2007). The current process of making these fibrin microthreads can be automated or manual by drawing the tube of fibrin in a series of lines through a pan of solution. Once solidified, the threads are taken out to dry and are readied for the bundling process to turn them into microthread sutures (Cornwall and Pins 2007).

Currently there is no mechanical device or system to bundle, by twisting or braiding, the microthreads into bundles and ultimately sutures; therefore, this process is done by hand, which leads to bundle inconsistencies. Our goal is to design a fibrin microthread bundling device that will improve the current process of making the bundles by easily attaching to the surgical needle, maintain similar properties to the current suture, have consistent suture production, be easy to manufacture, and be user-friendly.

There is also a clinical need for cell delivery via fibrin microthreads. Since these microthreads are composed of biocompatible and biodegradable biomaterials, they can be seeded with human mesenchymal stem cells (MSCs), which can then be sewn into the target area to deliver the cells to a specified area. A previous team has shown that the fibrin microthread sutures can in fact be seeded with MSCs, and still maintain their multipotency (Kowaleski, 2012).

During this MQP, our team will design and build a prototype of our suture maker and test the mechanical properties as well as the cell seedability of the produced bundles. In addition to building a prototype we will model our design in CAD and complete mechanical and cell seedability testing of the current handmade sutures for comparison to our produced sutures.

## Chapter 2: Background

Each year, 715,000 Americans suffer from a heart attack, and 600,000 die from all types of heart disease (CDC site, Heart Disease Facts). Heart attacks occur when blood flow has been cut off in one of the coronary arteries, resulting in myocardial infarction. When this happens, the cardiac muscle cells in the heart can die, resulting in a partially dead heart that is not operating at full capacity. As a result, studies have been conducted in an effort to develop methods to rejuvenate the damaged heart tissue and restore a patient's health.

### 2.1 Mesenchymal Stem Cells

Recently, cell-based therapies have become very popular in regenerative medicine. Mesenchymal stem cells, known as MSCs, are most commonly used in studies and research due to their ability to differentiate into other various types of cells and the fact that they can be found throughout the body (Barry & Murphy, 2003). These cells can be isolated from various tissues such as adipose tissue, peripheral blood, umbilical cord and placenta, as well as bone marrow (Barry & Murphy, 2003). They also have a remarkable capacity of extensive in vitro expansion which allows them to rapidly reach the desired number for in vivo therapy (Wang et al, 2012).

MSC's have been used to treat different kinds of problems like graft-versus-host disease, cardiovascular repair, skeletal muscle repair, liver disease and many others (Wang et al, 2012). The International Society even has defined MSC's by three criteria:

- (1) MSCs must be adherent to plastic under standard tissue culture conditions.
- (2) MSCs must express certain cell surface markers such as CD73, CD90, and CD105, and lack expression of other markers including CD45, CD34, CD14, or CD11b, CD79alpha or CD19 and HLA-DR surface molecules.
- (3) MSCs must have the capacity to differentiate into osteoblasts, adipocytes, and chondroblasts under in vitro conditions. (Wang et al, 2012)

MSCs can be obtained in more sufficient numbers for effective clinical treatment than other cell candidates such as cardiac stem cells and fetal cardiomyocytes, and thus have emerged as a potential cell type for different types of tissue repair (Murphy et al, 2008).

As the MSCs are able to differentiate into such a wide range of cell lines, they are useful in many regenerative medicine applications. These cells can be applied for the healing of several tissue types, and experiments have been conducted to evaluate the effect of the introduction of MSCs to damaged areas of the body. Areas seen to benefit from the stem cell therapy include nerve injury, skin graft survival, skeletal muscle defects, and damaged cardiac muscle.

### 2.1.1 MSC Regenerative Applications

For nerve cell healing, there has been work done with the neuro-regulatory molecules BDNF and  $\beta$ -NGF, which are expressed by certain MSC subpopulations. These neurotrophins were shown to correlate with the ability of the cells to assist in the survival and neurite formation in neuroblastoma cells and peripheral neurons within DRG explants (Crigler et al., 2006). The MSCs were also seen to secrete the glycoprotein prosaposin and the cytokine pleiotrophin. Though the effect of these molecules was not directly studied, they have been seen to stimulate neurite outgrowth in previous studies (O'Brien et al., 1994), (Li et al., 1990).

Further uses of MSCs have been examined and highlighted through their effect on skin graft survival in a primate focused study. An experiment was conducted to understand the relationship between the activities of MSCs in the bone marrow and a potential immunomodulatory effect on lymphocytes (Bartholomew et al., 2001). It was seen that baboon MSCs had suppressed the proliferative activity of allogeneic peripheral blood lymphocytes *in vitro*. When a single dose of MSCs was delivered intravenously, transplanted skin grafts were seen to have a statistically greater duration of skin graft survival.

For use in skeletal muscle defects, studies have been conducted to understand the roles of MSCs when applied to muscle tissue. Adult human synovial membrane-derived MSCs that were known to have myogenic potential *in vitro* (De Bari, et al., 2001) were used for skeletal muscle regeneration in a nude mouse model. The hSM-MSCs were seen to contribute to myofibrils and long-term functional satellite cells (De Bari et al., 2003), and were also characterized as being sensitive to environmental cues in the body.

## 2.2 Myocardial Infarction Treatments

With the mesenchymal stem cells showing such promise in tissue healing, they were seen as a potential treatment for the regeneration of hearts subject to myocardial infarctions. In humans specifically, cardiac tissue has low natural regeneration (Laflamme & Murry, 2011) and is slow to heal on its own. In addition, the therapies for the infarctions are limited and not as effective as they could be. As a result, the application of MSCs to damaged cardiac tissue has been studied as a novel treatment option.

Studies have been conducted to evaluate the effects that the stem cells have on the infarcted tissue, and to show the beneficial effect they have. Applications methods vary, but have included intravenous (IV) cell delivery, intramyocardial (IM) injection, intracoronary (IC) cell delivery, and cell seeded scaffolding. These delivery methods result in varying levels of success in partial cell engraftment for each distribution mode.

For IV cell delivery, a study examined the delivery of bone marrow derived mesenchymal stem cells (BM-MSCs) for myocardial repair after infarction. The BM-MSCs were procured from rat bone marrow, and were transfused into the left ventricular cavity of the rats. The cells were found to have a retention in the heart of less than 1% in the first hours after transplantation, most cells were found to coalesce within the lungs, with additional cells found in the liver, spleen, and bone marrow (Barbash et al., 2003)

Further studies were completed on the distribution of peripheral blood mononuclear cells (PBMNCs) after being delivery to the heart by different means. For IM injection, the anterior surface of the heart was exposed through opening the pericardium, and a suspension of cells was injected at 10 evenly spaced sites in the anterior left ventricular wall. This method was found to result in 26% of the cells found in the lungs, and 11% retained inside the myocardium. For IC delivery, an angioplasty balloon was inflated at low pressure inside the infarcted artery, and cells were infused over 30 to 45 seconds, with the balloon being deflated after 3 minutes. The IC cell delivery lead to 47% of the cells localized in the lungs, with a 2.6% retention of cells in the myocardium. In both experiments, the animals were euthanized one hour after cell delivery to evaluate the cell retention rate (Hou et al., 2005).

As an alternative to the stem cell injections, an epicardially applied cardiac patch, which contained human-MSCs, was used to evaluate the potential for increased exogenous cell engraftment. The hMSCs were embedded into a type I collagen matrix obtained from a rat tail, and the patch was then secured to hearts with fibrin sealant after induced myocardial infarction. The patch was found to have a cell engraftment of 23% after 1 week in the body, after the patches were cultured for 4 days (Simpson et al., 2007). Though more effective than other treatment options, the graft is not able to properly aid in the regeneration of the cardiac tissue on the inside of the heart walls.

The research has shown that stem cells can be applied to damaged areas of the heart, but such procedures can often lead to the presence of the stem cells in other non-targeted areas. The movement of the MSCs in itself does not pose a large risk, but allowing the cells to circulate throughout the body may have detrimental effects on the patient. Studies have proven that MSCs may affect cancer progression, with experiments showing cancer growth initiation *in vivo*, and cell transformation into malignant cells *in vitro*, though no definite evidence supports spontaneous *in vitro* human MSC transformation (Torsvik & Bjerkvig, 2012).

Further work has been done to develop a method of localized stem cell delivery for an additional way to administer cells for cardiac muscle cell regeneration. Fibrin microthreads were created through an extrusion of fibrinogen and (thrombin from bovine plasma), and were then bundled together in groups and then seeded with MSCs for cell delivery (Proulx et al., 2010). The bundles are then attached to a needle and recombined to create a biological, cell seeded suture. The suture is transplanted into the heart at the site of damage, and removed at a later time. This method was seen to result in a cell delivery efficiency of 63% *in vivo*, 1 hour after suture implantation (Guyette et al., 2012).

### 2.3 Biological Value of Fibrin

Within the body, fibrinogen and thrombin react as part of the wound-healing cascade. The reaction of these two compounds, in conjunction with production of platelets, produces a provisional extracellular matrix. Ultimately, it is through this process that fibrin clots are able to form. When this is reproduced *in vitro*, the produced fibrin clots have poor mechanical properties because the structure of natural *in vivo* fibrin is amorphous

(Cornwell, 2007). In order to take advantage of the wound-healing characteristics of fibrin, the compound must be modified in order to be successful.

## **2.4 Fibrin Microthread Production**

The fibrin microthreads used for our project were produced by VitaThreads using a modified automated version of the procedure described in the Kornwell and Pins' 2007 article (Kornwell & Pins, 2007). A set of two 1 mL syringes, one of fibrinogen and the other of thrombin are coextruded using a control syringe pump at a constant rate. The two solutions are then combined within the blending connector, which is then extruded through a single needle into a polyethylene tube into a bath. The threads are left in the bath to allow for the complete polymerization of the fibrin. The fibers are then removed from the bath and air-dried on the rack.

### **2.4.1 Fibrin Microthread Bundling Process**

From these threads, bundles are produced. Bundles consist of a group of threads that have been carefully twisted and bound together using the attachment properties of the threads when exposed to water. VitaThreads currently uses a method of taping either end of a group of dry threads and twisting until there is approximately one twist per cm. Once the bundle is twisted, the bundle is then hydrated and then left to dry. Once dry, the bundle is threaded through a surgical needle. The bundle is finally doubled over bundle is then twisted again, in the counter direction of the original twist, to produce a combination Z and S twist. Alternate processes for the bundle making process include wetting the threads for the duration of the twisting process, although no studies has been done to determine if there are any differences in the bundles produces from these processes.

## **2.5 Physical Properties of Fibrin Microthreads**

The physical properties of fibrin microthreads have been thoroughly researched. Previous studies have reviewed the mechanical properties and cell seedability of both the threads and bundles (Proulx et al., 2010, Guyette et al., 2012). Other studies of the threads have reviewed the effects of crosslinking and other potential strengthening techniques to the microthreads (Cornwell & Pins, 2007, Graman et al, 2012).

### 2.5.1 Mechanical Properties of Fibrin Microthreads

There have been several different studies done to review the mechanical properties of fibrin microthreads. Due to the significant differences in mechanical properties of fibrin microthreads, the process by which the threads were produced has had a significant impact on their mechanical properties. Previous published studies have shown that the threads have significantly different moduli depending on the diameter (Cornwell & Pins, 2007, Grasman et al, 2012). Through the automation of the thread making technique that VitaThreads currently uses, in addition to standardizing the bundling process through this project, the variability in mechanical properties should be minimized. In previous studies of fibrin microthreads, mechanical properties have been measured using a series of uniaxial loading Instron tests. Through the stress-strain curves the failure strain (FS), ultimate tensile strength (UTS), and the maximum tangent modulus ( $E$ ) were calculated for the bundles (Cornwell & Pins, 2007). The calculated results found the FS, UTS,  $E$  to be  $0.31 \pm 0.15$  (mm/mm),  $4.48 \pm 1.79$  (MPa), and  $60.70 \pm 2.71$ (MPa) respectively (Cornwell and Pins, 2007).

### 2.5.2 Cell Seedability of Fibrin Microthreads

Several previous studies have detailed the cell seedability and cell proliferation of cell attached to fibrin microthreads. Following standard cell seeding and passaging techniques to the microthreads, live/dead cell viability stains were conducted at days 1 and 7 or 3 and 7 (Cornwell & Pins, 2007, Grasman et al., 2012).

### 2.5.3 Effects of Crosslinking on Fibrin Microthreads

In an effort to strengthen fibrin microthreads, research has been done to study the effects of typically strengthening techniques such as UV light exposure. UV exposure proved to increase several mechanical properties of the threads, such as the ultimate tensile strength (UTS), but had negative effects on cell proliferation and thread swelling (Cornwell & Pins, 2007). Different methods of crosslinking have been shown to have little to no effect on cell proliferation and cell viability, two of the factors that had previously been impacted (Grasman et al, 2012). Ultimately, more research is needed to determine if



the positive effects of some methods of UV crosslinking can be exploited for use in microthread sutures to enhance mechanical properties.

## 2.6 Suture Production

The existence of sutures has been prevalent in the medical industry for thousands of years. In ancient India, physicians used the heads of beetles or ants to effectively staple wounds shut (Inc, 2013). The live creatures were affixed to the edges of the wound which they clamped shut with their pincers. The bodies of the insects were removed and mouths left behind fastening the wound together as seen in Figure 1. Doctor's also utilized flax, hair, grass, cotton and silk as natural material sutures.



Figure 1: Ant heads used as ancient sutures (by Van Thi Hong Tran, 23 May 2012, [vanttran.tumblr.com](https://www.tumblr.com/vanttran) 23 May 2013.)

Sutures are designed for different applications with varying qualities. In this research paper the team is investigating a means to design and build a machine capable of twisting or braiding fibrin microthreads embedded with hMSC stem cells into a bundle for treatment and regeneration of cardiac infarctions. In this section we explore methods that are used in the textile industry to twist and braid certain materials into fabric.

## 2.7 Current Thread and Rope Making Processes

The overall process in making a suture is very similar to the methods used in the textile industry. In the manufacturing process the first step is the production of raw polymer. The raw polymer is then forced through a die and discharged as tiny pellets. The pellets are then placed in an extrusion machine and form individual filaments. Filaments are stretched between two rollers. Some sutures are manufactured as monofilaments and others are braided or twisted. In order to braid a suture the extruded filament can be wound onto bobbins. The bobbins are loaded onto an automatic braiding machine. The process here does not require a lot of human intervention only to the point of accessing the machines workability. After filaments are braided a number of secondary processing steps are carried out depending on the type of bundle being manufactured. Each bundle is inspected for either heat-treated or to be hydrated until desired suture is produced. A quality inspection is done to evaluate the diameter, length, and strength of the bundle. Next the bundle is attached to a needle and packaged. The needles are usually produced at another manufacturing plant. The final packaged suture is sterile and ready for surgery.

### 2.7.1 Braiding Machines

Strand-forming braiding machines have horn gears arranged on a braider table. The gears turn in opposite direction. This is necessary for the drive mechanism of the bobbins. In accordance with the number of reparations the bobbin feet are taken from the neighboring horn gear to the next one to pass them on. This means that the bobbin alternatively uses the front and back of subsequent horn gears. A wavy movement path is cut in the braider table underneath the horn gears. The sliding shoes of the bobbins move in that groove and guide the bobbins along the closed path. Each bobbin therefore moves around each horn gear. Intersection of the braiding threads develop at the cross spots of the cut path by simultaneous movement to the left or to the right of one half the bobbins (Burkhard Wulfhorst, 2006). Circular braids can be produced by a closed horn gear arrangement. The bobbins move on two closed paths rotating around the center. One part of the bobbins moves to the left and the other moves to the right, as seen in Figure 2.

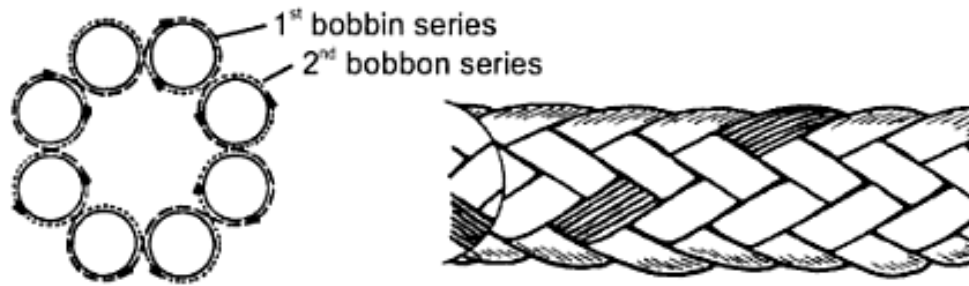

Figure 2: Schematic diagram of circular braiding arrangement (Burkhard Wulforth, 2006. 23 May 2013).

### 2.7.2 Maypole Braiding Technique

The invention of a commonly used technique to braid individual threads into a braided rope is known as a Maypole Braid, this type of braiding technique is utilized in textile, marine and suture industry to manufacture desired braiding arrangement. The methods employed and the apparatus utilized in producing a conventional two over, two under braid vary to some degree. A Maypole or sinuous braiding technique optimizes wherein the strand carriers are moved in intersecting serpentine paths on a braiding deck as the strands are let off under tension onto the tubular structure to be reinforced which is pulled at a uniform rate in a direction perpendicular to the deck (Richardson, 1993). Although early forms of Maypole braiders utilized various mechanisms for driving the carriers in opposite directions around sinuous tracks mounted on the braider deck, modern Maypole braiders utilize planetary gearing and a cam track and cam follower system on the carriers and drivers to eliminate the sinuous tracks and their attendant high friction and wear problems. Figure 3 below highlights the design of the gear and sprocket assembly of a machine that utilizes this technique.

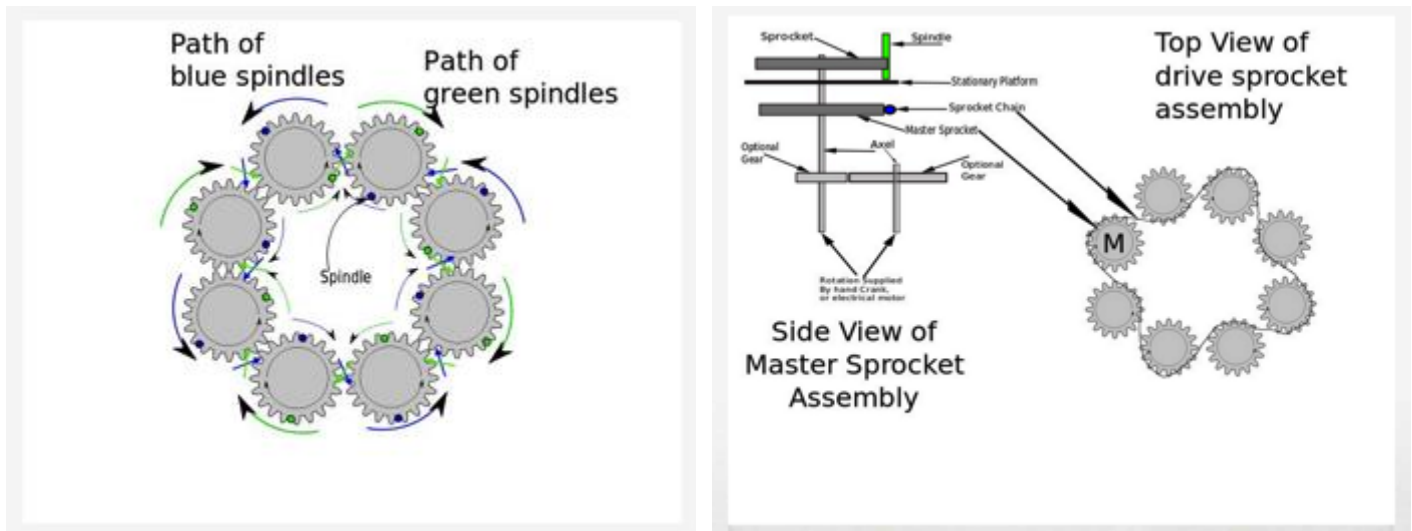

Figure 3: Maypole Braiding Machine Gear and Sprocket Assembly  
[\(http://www.instructables.com/community/Can-anyone-build-a-hand-crank-braiding-machine-S/\)](http://www.instructables.com/community/Can-anyone-build-a-hand-crank-braiding-machine-S/).

### 2.7.3 Marine Industry Techniques

The marine industry requires the use of high strength ropes for use in daily activities. High modulus synthetic fibers have been commercially available for over (40+) years, starting with Kevlar® aramid. In addition to Kevlar and other aramids such as Technora®, HMPE (Spectra® and Dyneema®) and Vectran® Liquid Crystal Polymer (LCP) fibers are now also utilized in high performance ropes, with HMPE constructions proving to be the most versatile across a broad range of applications. Synthetic fiber rope constructions made with these types of materials can equal or exceed the tensile strengths of steel wire ropes (Greenwood, 2006).

## Chapter 3: Project Strategy

In order to create a complete project strategy for a fibrin microthread bundling device, the team needed to interpret and revise the initial client statement as well as develop objectives based on a qualitative assessment of the important goals for the project. From the revised client statement and clearly defined objectives and goals, the team was able to derive the functions of the device. With this information the team was able to gain a complete understanding of the problem statement and was able to develop preliminary designs and experiments and test design concepts.

### 3.1 Initial Client Statement

During the team's first meeting with Prof Gaudette, they were given the challenge of developing a device to consistently bundle fibrin microthreads for suture production. The following was the initial client statement:

“Design a device/system to reproducibly create a biological suture from fibrin microthreads. The system should allow for different numbers of fibrin microthreads to be used, be user friendly and not have detrimental effects on the fibrin microthreads.”

Although there is currently a handmade method for producing fibrin microthread bundles in use, there are several inconsistencies associated with this bundling process that prevent it from being applied to large-scale commercial operations. From the initial client statement and the team's comprehensive understanding of the problem at hand, the team was able to develop a project strategy and refine a list of objectives and functions.

### 3.2 Design Objectives and Constraints

Based off the team's initial design meetings and tour of the VitaThreads' lab space, the team developed a list of objectives and constraints for the design. These objectives were based off of the team's background research and discussions with Prof Gaudette and the client, Adam Collette the President of VitaThreads, as well as potential users, members of the Gaudette Lab and the VitaThreads production team.

### 3.2.1 Initial Design Objectives

The five primary objectives that the team identified, in no particular order, were:

- Easily attachable to a surgical needle
- Maintain similar physical properties to current sutures
- Produce consistent bundles
- Easy to manufacture
- User friendly

Under maintaining similar physical properties, three types of properties were identified, cell seedability, biocompatibility, and mechanical properties. Under manufacturability, two secondary objectives of inexpensive production as well as can be scaled-up for commercial production were identified. Finally, safety and easy to use were identified as the secondary objectives for the user-friendly objective. An objective tree of the team's primary and secondary objective can be seen in Appendix A: Design Objectives Tree.

### 3.2.2 Qualitative Assessment of Objectives

Once the team had fully developed, defined, and grouped the objectives, it was necessary to compare these objectives to each other in order to determine the most important objectives and to revise the client statements. In order to rank these objectives against each other, a pairwise comparison chart was used to determine the ranking. Pairwise comparison charts were given to the project advisor, the client, as well as potential users within the VitaThreads and Gaudette labs, totaling 5 responses. The pairwise comparison chart used each of the five primary objectives and compared them to each other. The chart only allowed for two responses, either a ranking of more important or less important. The objective in the horizontal row received a score of 1 over the objective in the vertical column if it was more important and alternatively, a score of 0 if it was less important. The scores for each objective were counted horizontally across the chart, with the highest score ranking first and the lowest score ranking fifth.

In the case of two objectives receiving the same the ultimate total score, the ranking between those two objectives was revisited and the objective with more importance received the higher overall objective ranking. Upon receiving the completed pairwise

comparison charts, the team scored and the average ranking of the objectives was determine. The averaged results for pairwise comparison charts that the team handed-out to the clients, project advisors, and potential users can be seen in Table 1 and the team’s ranking of the objectives of can be seen below in Table 2.

**Table 1: Averaged objectives ranking from outside opinions**

<b>Ranking</b>	<b>Objective</b>
<b>1</b>	Produces consistent sutures
<b>2</b>	Maintains similar properties
<b>3</b>	User friendly
<b>4</b>	Attaches easily to needle
<b>5</b>	Manufacturability

**Table 2: Team's objectives ranking**

<b>Ranking</b>	<b>Objective</b>
<b>1</b>	Produces consistent sutures
<b>2</b>	Maintains similar properties
<b>3</b>	Attaches easily to needle
<b>4</b>	User friendly
<b>5</b>	Manufacturability

While Table 2 represents the average ranking, there were significant differences in opinion by the stakeholders as to the ranking of certain objectives. One such disparity was that the client ranked manufacturability as most important, while the averaged ranking for this objective was last. This reinforced the team’s understanding that for the client, the ability to manufacture and integrate the device into their current operation was of the utmost importance.

In general, the team’s ranking was mostly in line with the average ranking of surveyed individuals, as seen in Table 1 and Table 2; the only difference was that user friendliness ranked higher than needle attachment. From this, the team recognized that the

user-friendly objective should be reviewed and highly considered throughout the design process.

### 3.2.3 Design Constraints

The team developed a set of initial constraints for the design based off the meetings with Prof Gaudette and VitaThreads employees. The initial constraints developed can be seen in Table 3 below.

**Table 3: Initial Design Constraints**

<b>Constraint</b>	<b>Definition</b>
<b>Money</b>	Budget of \$624
<b>Size</b>	Must fit on lab bench
<b>Time</b>	Must be finished by end of E Term 2013
<b>Safety</b>	Must be safe for user
<b>Materials</b>	Must be non-reactive

The budget for this project was determined by the BME department budget per MQP team member of \$156, giving the team \$624 for the project. Through the team's visit to the VitaThreads lab space, it was determined that the device must be small enough to be stored on the lab bench. Since this project was conducted during E-Term, the entire project must be completed within a seven-week time frame, ending on June 28, 2013. The team also considered that materials that the device could be made from. The materials that the microthreads would come in contact with could not have any harmful or detrimental effects on the bundles being produced.

### 3.3 Revised Client Statement

After completing background research and developing the objectives for the project, the team revised the client statement to reflect the goals of the project as the team identified them. The revised client statement is as follows:



Design a device/system to easily **produce uniform biological sutures** from fibrin microthreads with a consistent amount of twists per unit length. The system should bundle a **range fibrin microthreads**, be **user friendly**, be **inexpensive to manufacture**, and **should not significantly impact the physical properties** of the final suture. The resulting bundles should also be able to **easily interfaced with a surgical needle**.

### 3.4 Design Functions and Specifications

Using the information learned for the literature as well as the refined understanding of the problem through clear objectives and client statements, the team was able to develop a comprehensive list of functions and specifications for the device.

#### 3.4.1 Functions

To determine the functions of the device, the team answered the question “*What must the device do?*” and developed the list of the following functions:

**Functions 1:** The device must produce a consistent twist or braid throughout the length of the sutures.

**Function 2:** The device must securely attach the microthreads and feed them into the bundling process.

**Function 3.** The device must continuously hydrate the microthreads.

**Function 4:** The device must make the microthreads handleable for bundling.

**Function 5:** The device must be user friendly and safe.

**Function 6:** The device must quickly produce bundled microthreads.

**Function 7:** The device must produce a bundle that can be easily attached to the surgical needle.

**Function 8:** The device must not significantly degrade the mechanical properties of the microthread bundles.

**Function 9:** The device must not significantly degrade the cell seedability of the microthread bundles.

**Function 10:** The device must produce microthread bundles that can be easily stored.

**Function 11:** The device must produce microthread bundles that can be easily sterilized.

### 3.4.2 Design Specifications

Based off of the functions, the team developed a set of specifications for the design. The limitations that the team faces with the design project are time, the small size of threads being bundled, the delicate nature of the individual fibrin microthreads, the length of each thread, and the budget given to the team. Taking into account the objectives, functions, and limitations the team has developed specifications for the device. The major specifications for the design are shown below. These were developed to achieve the specific needs of the design taken from the objectives and functions developed by the team. A full list of all specifications for the design can be found in Appendix B: Design Specifications.

**Produces bundles that can be made into sutures of at least 4 cm in length**

**Can bundle 1-24 microthreads**

**Can bundle microthreads of approximately 12 inches in length**

**Take a maximum of 30 minutes to produce a bundle**

**Produce approximately 1.5 twists per cm**

## Chapter 4: Alternative Designs

### 4.1 Needs Analysis

In order for the team to create a sound design the team had to answer the question of what the actual needs of the design were. Revising the client statement from the team's understanding of the clients wants was the first step taken. The team was also able to further refine the system's needs through bi-weekly meetings with professor Gaudette, an interview with Adam Collete, president of VitaThreads, and ranking of objectives from pairwise comparison chart handed out to the members of the Gaudette lab and VitaThreads employees. After reviewing the client statement and collecting the results from the pairwise comparison charts the team ranked the objectives, as shown previously in Table 2. The team also created a list of functions that the device must achieve. The list is highlighted in Section 3.4.1 Functions. The device must hydrate the threads as they are consistently twisted or braided into a bundle. The device must be user friendly and safe. Other important functions of the device is that they should produce a bundle that is easily stored, sterilized and can be easily attached to a surgical needle without degrading the mechanical properties of the threads. The limitations that the team faced with this design project were time, the small size of threads being twisted or braided, the delicate nature of the individual fibrin microthreads, the length of each thread and the budget given to the team. A Needs Analysis was conducted to better understand the requirements and specifications of the system. To do this, the design team identified objectives and classified them under "needs" and "wants". A system need was defined as a crucial system function that must be met for the system to be considered a success. A system want was defined as a desired objective by the user and client, but did not have to be met for success. The objectives developed by the team were broken up into system needs and system wants of the design and can be seen below in Table 4.

**Table 4: Needs and wants for the system.**

<b>Needs</b>	<b>Definition</b>
<b>Reproducible</b>	Ability of the system to produce thread bundles which have consistent bundle to bundle structural and mechanical properties
<b>Precise</b>	Ability of the system to produce thread bundles which have consistent spacing between each twist
<b>Minimize thread failure</b>	Ability of the system to minimize thread failure during production
<b>Automated Stretching</b>	Ability of the system to hold the threads in tension while bundling occurs
<b>Modifiable amount of threads</b>	Ability of the system to produce bundles with different number of threads
<b>Wants</b>	<b>Definition</b>
<b>Sterilization</b>	Ability all parts of the system to be sterilized
<b>Attach to the Needle</b>	Ability for the system to attach the bundle to the needle
<b>Manufacturability</b>	Ability of the system to be scaled up

### Systemic Needs

Pairwise comparison charts evaluated by the user, client, and design team were analyzed and quantified to create a list of systemic needs. “Reproducibility” and “Precision” were two objectives classified as systemic needs since the final design must produce thread bundles that have the same structural and mechanical properties as well as have consistent spacing between each twist within the braided bundle. The system must also be able to maintain tension while minimalizing thread failure during production and thus are also classified as systemic needs. The system as requested by the client and user should be able to have a modifiable amount of threads when bundling. This objective is classified as a systemic need as the design must be able to produce bundles with varying number of threads.

## Systemic Wants

Understanding the needs for the system was important, but understanding the wants was almost equally as important during the design process. Although needs were essential the objectives which should be met for a successful project, wants were objectives which would ideally also be met. Wants were classified during meetings with the client and user as well as through the analysis of objectives.

Manufacturability and an attachable interface of the bundle to the needle were identified as wants. The secondary objective of interfacing the twisted bundle with the surgical needle would make the overall design more complicated, and due to the time and budget constraints, out of the realm of this project. These objectives were not essential in terms of device success, but would be included in an ideal system. For the system to be ideal it would need to have the ability to be scaled up and interface with the suture needle, and produce sutures consistently but due to limitations highlighted above they were identified as wants. Sterilization was also identified, as an objective want for the system. The primary goal of the system was to produce and consistently bundle threads while minimizing thread failure. However, in an ideal system, the threads would be produced and modified in terms of sterility for other experimental needs, which did not fall within the scope of this project.

Table 5: System Design Matrix

	<u>Needs</u>					<u>Wants</u>		
	Reproducible	Consistency	Minimalize Thread Failure	Automated Lifting	Securely attach and feeding	Sterilization	Attach to Needle	Manufacturability
Size of system						X		X
Thread Capacity	X	X			X		X	
Maximum Stress on threads		X	X	X			X	
Maximum Stretch of threads		X	X	X				
Spacing between Individual Twist	X	X						X
Finite Thread Length	X			X				X
Bundling Time	X	X						X

As shown above in Table 5, the matrix compares needs and wants with corresponding systemic specifications. The columns denote the identified needs and wants for the system, whereas the rows denote specific design criteria. An X denotes affected objectives by the design criteria. For example, the specification for the ‘maximum stress on the threads’ directly affects the needs ‘minimal thread failure’ and ‘automated stretching’ as well as the want of ‘manufacturability’ for the system. Because the ‘minimum thread

failure' and 'automated stretching' of the threads were identified as needs, the stress on the threads must not prevent these objectives even at the cost of manufacturability. The purpose of this design analysis was to identify the relationships between specific designs and the needs and wants of the system.

## 4.2 Conceptual Designs

In the process of designing a suitable device that would be able to conform within the desired objectives, constraints, functions, and specifications, several preliminary design concepts were discussed and considered along the way. As the two primary functions that were identified were the bundling mechanism and the hydration mechanism, the potential means for achieving these functions were often the focus for the conceptual designs.

Possible means for the bundling of individual threads included twisting the threads or braiding the threads. Either system could be modified based upon the desired number of threads to be included, the number of threads paired with each other, and the action of bundling. The thread/bundle hydration mechanisms involved spraying/misting, the use of a humidifier, the application of droplets, or complete submersion in liquid during bundling to keep the microthreads well hydrated.

### 4.2.1 Bundling Through Twisting

The first recorded conceptual design was a simple idea that consisted of two concentric, separated circular plates with holes in them to hold and guide the microthreads. The two plates would turn counter to each other, resulting in a twist forming in the threads in the middle of the gap between the two disks and spreading outwards from there. For hydration, simple application of droplets of water or PBS was considered, allowing them to run down to the center of the device, at the bundle formation. This presented the initial concept of using a rotating plate to create a repeatable twist with the threads, as well as using holes to guide the threads.

The next design followed a similar bundling procedure of twisting the threads together through counter rotations at the two ends of the threads, but was arranged horizontally instead of vertically. In addition, the attachment points for both thread ends were grouped into small areas. This allowed the potential for a surgical needle to be

slipped onto the group of microthreads and for the twisting to occur with the needle in place, to simplify the process of twisting the bundle into a suture after being attached to a needle. This was the first concept to implement the idea of having a needle in place as the bundle/suture is created to remove the attachment step. It was ultimately decided that the needle attachment would not be necessary in the final design.

Following the theme of twisting the threads together, the next concept came about as a result of discussions for potential hydration mechanisms. With the possible hydration methods including the system being completely submerged, the idea was presented of using the whirlpool effect to achieve the desired twisting. The threads would have been suspended into the water, and ideally twisted together into a bundle by a vortex in the water, generated by unspecified means. This concept was not pursued, but presented the possibility of complete hydration of the threads and the bundling device during the bundling process.

With many simple sketches completed in the pursuit of a reliable design, a more in depth and detailed illustration and description was completed for the next conceptual design. The mechanism consisted of threaded base rings that would revolve around and upwards on a central screwed column, with the threads coming down from a secondary piece at the top of the column and attaching to the base disks. The structure included a limiter to prevent the possibility of over bundling the threads, as well as a turning knob at the edge of the disks for control of the twisting motion. Several possibilities were discussed for hydration techniques, and included a mist or spray in various directions, direct hydration application to threads through holes, and possible complete system submersion. Notable desired aspects in the system were fixed thread position during bundling, a gentle interaction to avoid breaking of threads when clamping, and the sliding towards center motion. This design really brought out the more advanced device possibilities for the twisting mechanism as a way of providing a more comprehensive mechanism for the bundling process.

#### ***4.2.2.1 Preliminary Design Mechanisms for Twisting***

Moving back a step, the next design concept was for a bundling system with a simple twist as the mode of operation, similar to previous screw ideas. A circular plate with



threads feeding up through it would have been fixed to a threaded column, which extended outwards below it. The column would have threaded into a base, such that as the column moved downwards, it would rotate a fixed amount for the distance traveled, creating a consistent and reproducible twist. This design was meant as a way to solidify the twisting motion into a device that was deemed reliable and feasible as a potentially simple option to execute if the braiding designs were determined to be too complex.

The next concept that was detailed for a potential twisting mechanism was a hollow tube separated into two pieces, designed such that the threaded would pass through the tube. As the two halves of the tube were turned counter to each other, the threads would bundle into a twist in the center of the tube and the twist would then propagate outwards. This concept placed a focus on the idea of having the inside of the tube be a hydration chamber for the threads, with the compact design allowing for a potential complete submersion. This design was meant as a secondary way to create a twisted bundle such that the device allowed for an alternate mode of operation.

Initially designed with another mechanism in mind, the following concept emerged when its original intended mechanisms was seen as being fundamentally flawed. The concept revolved around two separated disks, each containing half of the threads, spinning counter to each other while one set of threads went around the other set. The idea was ultimately seen as not being able to produce the intended bundling upon inspection, but instead yielded a different thread bundling technique. The device would result in a double twist, such that it contained two sets of threads, each twisting in opposite directions. This system introduced the idea of having the double twist in the bundle as an alternative to a simple twist, though still not a full braid. This system also continued the theme of being about to produce different types of twists with changing out the disks used for attaching and twisting the threads.

#### **4.2.2 Bundling Through Braiding**

For an alternative approach to the bundling procedure, a simple design was sketched out that consisted of threads following a sinusoidal track patterned around a disk in order to bundle the threads. The motion would have been such that the resulting bundle would have been braided in the fashion of a maypole braid, in order to increase the

mechanical properties of the final suture. This ultimately introduced the potential of combining the threads into a braid for increased strength, as opposed to the currently produced twists.

From there, the designs progressed to a greater focus on the creation of a system that would be able to result in bundling the threads into a braid instead of a twist. A design was suggested that was aimed at producing a braid based upon the current techniques for braid production that are utilized in the textile industry. The concept focused in on a specialized base which would have allowed for multiple threads to be threaded into one of several disks inside the base, which would have been rotating about the center with each other. The design introduced a potential reliable and concrete method of producing a bundle with greater strength than the twisted bundles, as well as being able to create different types of bundles in one machine.

With a focus on the braiding possibilities, the next conceptual design was planned such that it would be possible to produce a braid in the maypole style, a type of braid that was shown in literature to be common and effective. The structure of the device would have consisted of a series of interconnected gears in a base disk around a center point for the threads to twist about, with the thread attachment point being interchanged between gears and rotated about the ring. This design also allowed for more than one bundling type, along with introducing the maypole braid technique, especially through using a series of gears.

### **4.3 Preliminary Designs**

After background research into the textile and rope industry, the team noticed a common braiding technique across all industries including rope and lace manufacturing. The type of braid produced was noted for stronger tensile strength and increased ultimate tensile strength. The technique used is called the Maypole braid. In our first conceptual design the team set out to build a machine that braided the fibrin microthreads in a Maypole braid. The team also came up with several other twisting techniques that do not braid in the over under pattern like in the Maypole technique. The team came up with four preliminary designs for the suture maker.

#### 4.3.1 Maypole Single and Double Braid Design – Preliminary Design 1

The Maypole machine is utilized in shoelace manufacturing as well as the marine rope industry shown in Figure 4. The Maypole braiding machine has a multiplicity of spool carriers each provided with follower means arranged to co-act with a fixed circular guide track of double undulating and intersecting form and with drive means arranged to engage with recesses on horn gears arranged in a circular, meshing array and respectively carried on pillars positioned centrally of the individual undulations. Upon driving the horn gears the recesses propel the spool carriers along the undulating and intersecting guide track such that one group of carriers moves in a circular direction and the other group of carriers moves in the opposed circular direction and, following the intersecting undulations, alternately pass radially inwardly and radially outwardly of each other. Strands of the spool carriers are paid off to form a braided sheathing co-axially of the central axis of the braiding machine by virtue of the contra-rotating intersecting undulating paths of the spool carriers (John R Jones, 1988).



Figure 4: Maypole machine used in textile and rope industries

#### 4.3.2 Jelly Fish Design – Preliminary Design 2

Out of the maypole design the group attempted to mimic the sinusoidal path of the maypole braiding machines currently available. The design included two separate disks of opposing circular motion and was meant to create the maypole braid and is referred to as the Jelly Fish Design. Although the design failed to make the maypole braid the resulting

machine allowed for multiple twists to be made around a center twisted strands. This design has been modeled, included as a preliminary design and will be evaluated for viability. A simple CAD drawing of this design is show below in Figure 5.

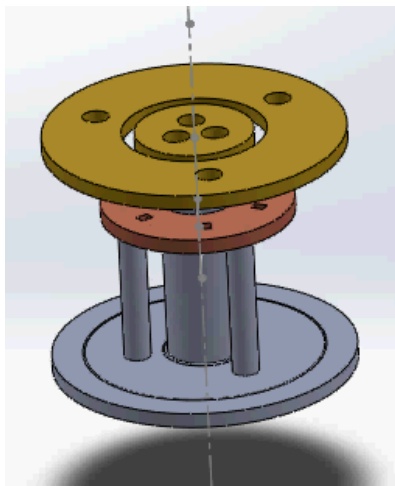

Figure 5: CAD model of Jelly Fish Design – Preliminary Design 2

#### 4.3.3 Screw and Plate Design – Preliminary Design

After investigating similar industries and arriving at the Maypole machine and then failing in an attempt to modify the maypole design and still achieve a maypole braid resulted in a complicated twist technique the team began to brainstorm. In brainstorming the current method used by VitaThreads to twist the fibrin microthreads and bearing in mind the second preliminary design the team came up with a third design, this design is referred to as the Screw and Plate Design. The design comprised primarily of a disc with multiple apertures for thread attachment and a screw system intended to maintain equal spacing between each twist. The threads would be fed into the disc via tubes with hold them hydrated as the disc spun around the center screw. Below in Figure 6 is a CAD drawing depicting the third preliminary design.

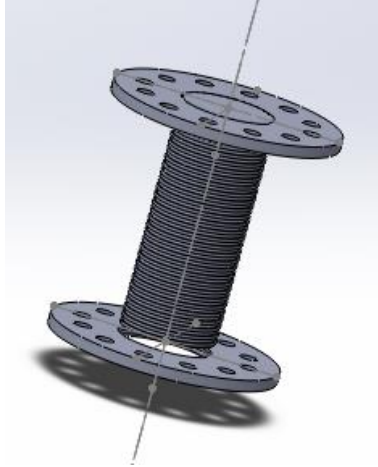

Figure 6: CAD model of Screw and Plate Design – Preliminary Design 3

#### 4.3.4 Simple Twist Design – Preliminary Design 4

The team's fourth and final preliminary design is mechanically the simplest as it has fewest parts. Although the design is simple it achieves the primary function of a suture maker. This design is comprised of two primary parts, two cylinders one with smaller diameter so that it can fit inside the other part. Apertures on either end of the cylinders allow for insertion and attachment of fibrin microthreads. Slits in the face of the cylinder allow for insertion and attachment of fibrin microthreads. Slits in the face of the cylinder allow the threads to be seen as twisting occurs. The cylinders follow a threaded path and the end result is a uniformed twisted bundle of fibrin microthreads. Shown below in Figure 7 is a CAD drawing of the simple twist design.



Figure 7: CAD model of Simple Twist Design – Preliminary Design 4

## 4.4 Design Modeling

To gain a better understanding of the concepts and braiding techniques that were involved in the preliminary designs, the team conducted small scale modeling of different braiding techniques as well as design concepts.

### 4.4.1 Maypole Braiding Technique Modeling

In order to get a hands-on understanding of the sutures and how it would form a maypole braid, the team conducting modeling of the braiding patterns of the maypole technique. After braiding once with sutures, the team quickly switched to a thicker material of blue yarn to model the fibrin microthread made the braiding much easier to visualize. As a team, we modeled a single and double maypole technique braid around a graduated cylinder. Figure 8 below shows the single and double braid made out of yarn. From this modeling, that the team decided to begin brainstorming the Jelly Fish design shown earlier in Figure 5.



Figure 8: Left - Single yarn braid from Maypole technique. Right - double yarn braid from Maypole technique.

### 4.4.2 Design Concept Modeling

Cardboard was used to build some simple models so that the team could test the viability of a conceptual design before building a prototype. A cardboard model of the simple twist design was assembled. Cardboard was also used to model the discs for the Screw and Plate design as well as the discs for the Double Twist design. Both cardboard models are shown below in Figure 9.

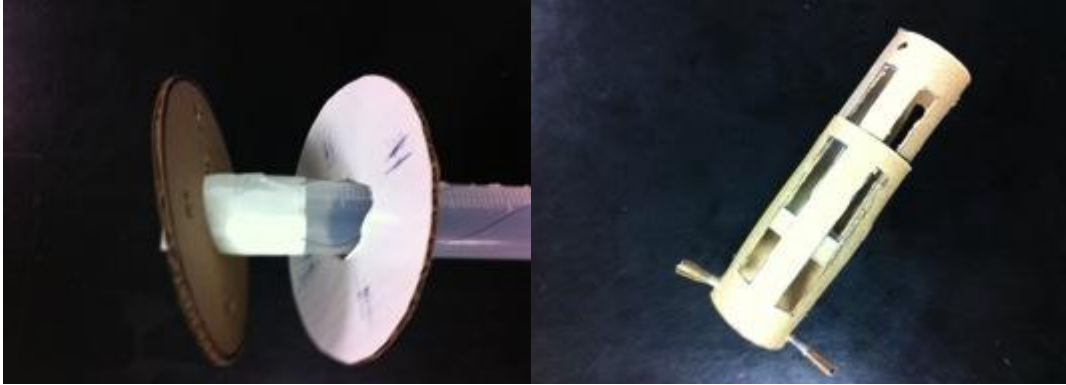

**Figure 9: Left - Cardboard model of Screw and Plate Design. Right - cardboard model of Simple Twist Design.**

The team used the software, Solidworks, to build each part and assemble a model of each of the alternative designs highlighted above. The team also ordered Lego gears in order to assemble the maypole design. Several CAD files the discs were created in Solidworks.

#### **4.5 Feasibility Study and Preliminary Experiments**

In order to gain a better understand of the properties of the fibrin microthreads, the team conducted several experiments using threads and bundles provided from VitaThreads. The team evaluated the mechanical properties through uniaxial tensile testing using Gateway's Instron Eletropuls e1000 machine and the hydration of the microthread through imaging bundles.

##### **4.5.1 Mechanical Testing – Preliminary Experiment**

The team preformed uniaxial testing on Gateway's Instron Eletropuls e1000 machine, seen below in Figure 10.

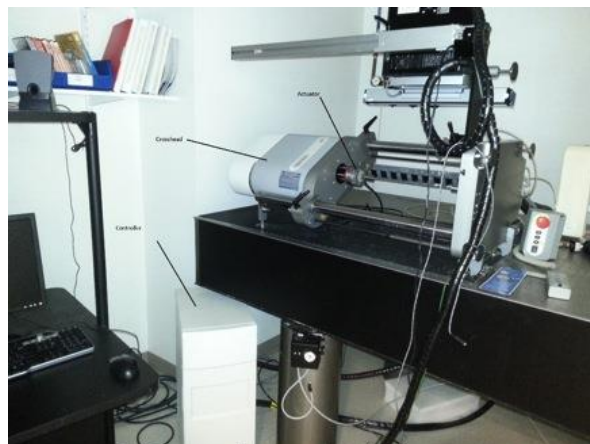

**Figure 10: Gateway's Instron Machine used for uniaxial mechanical testing.**

Samples for this preliminary testing were cut from bundles provided by VitaThreads. Eight samples of approximately 5 cm in length were cut from four VitaThreads bundles. The samples were left to hydrate overnight (17 hr) before mechanical testing and continuously hydrated throughout the testing process. Samples were first imaged using the Leica DM LB2 to determine the diameter of the each sample. Five images were taken of each sample, and an example of the images taken can be seen in Figure 11.

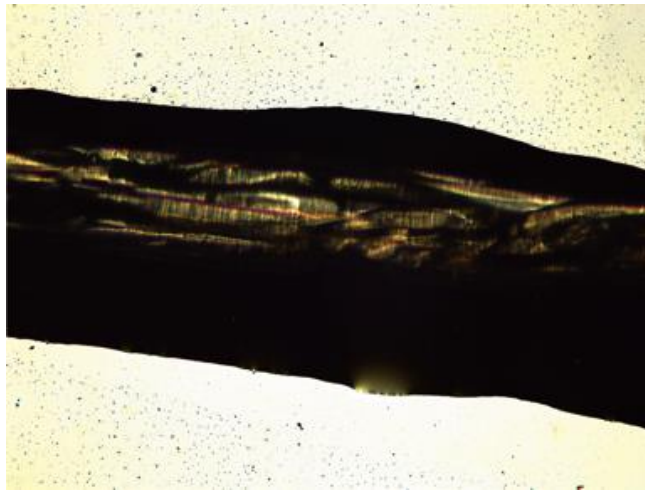

**Figure 11: A sample image of taken of a microthread bundle used for mechanical testing**

The Instron was setup with the 1 N load cell and calibrated to the custom grips used for microthread testing. The grips are comprised of a rubber section where the sample is laid down across the two grips. The grips are then secured with metal rods placed over the rubber portion of the grip and screwed down into place, as seen below in Figure 12.

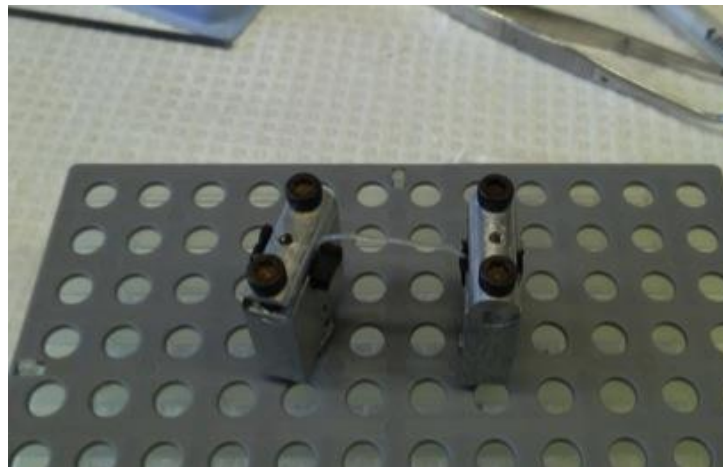

**Figure 12: A microthread bundle sample loaded into the custom grips used for uniaxial mechanical testing.**



Once the sample was loaded into the grips, the grips were then loaded into the Instron Eletropuls e1000 machine at WPI's Gateway Park, as seen below in Figure 13. After the sample was in place, the gauge length was measured and the sample was tested until failure. The bundles were pulled at a rate of 50% strain per minute.

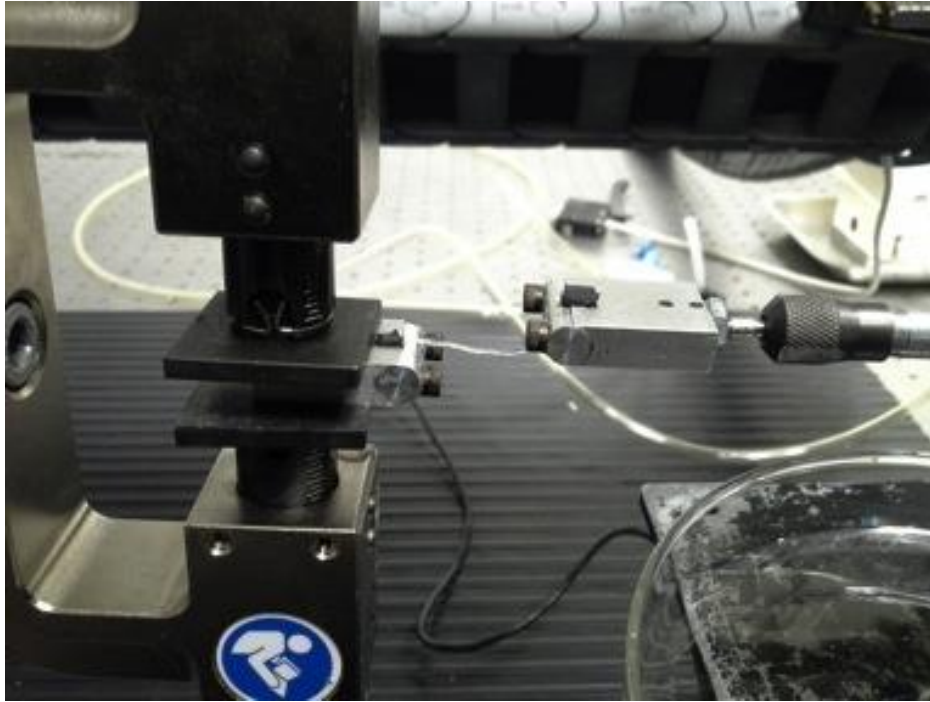

**Figure 13: The sample loaded into the Instron machine ready for testing.**

The Instron raw data and the images from the microscope were used in conjunction with a MatLab program to analysis and determine the average diameter, ultimate tensile strength (UTS), yield strength (YS), failure strain (FS), and modulus of elasticity ( $E$ ) for each sample. The UTS was calculated as the greatest magnitude of stress that the sample experienced, the YS was measured as the point at which the stress-strain curve began to exhibit plastic deformation, the FS was the strain at which the sample broke, and the modulus was calculated as the slope of the stress-strain curve. In order to determine the average diameter, two measurements were taken of each image and the resulting ten measurements were averaged together for each sample. A complete protocol for the uniaxial mechanical load testing can be found in Appendix C: Instron Testing Protocol for Microthread Bundle.



## 4.5 Preliminary Data

### 4.5.1 Mechanical Testing Results

The team calculated the UTS, YS,  $E$ , and FS for each sample. From the eight samples, the mean and standard deviation was calculated for the sample set. These calculated values are seen be found in Table 6.

**Table 6: Calculated results of preliminary mechanical testing on microthread bundles.**

	<b>Mean <math>\pm</math> SD</b>
<b>YS (MPa)</b>	0.39 $\pm$ 0.19
<b>UTS (MPa)</b>	1.07 $\pm$ 0.68
<b>FS (mm/mm)</b>	1.33 $\pm$ 0.32
<b><math>E</math> (MPa)</b>	0.41 $\pm$ 0.17
<b>Diameter (<math>\mu\text{m}</math>)</b>	488.9 $\pm$ 150
<b>Length (mm)</b>	24.88 $\pm$ 3.44

## Chapter 5: Design Verification

The team used several different tests to determine how consistent the device was to the current practices that VitaThreads uses. Three tests were conducted, each to evaluate a different desired property of the final system. The three tests were

- Uniaxial load testing: to determine mechanical properties of the bundles
- Consistency testing: to determine the consistency of twist in each bundle
- Cell seedability testing: to determine cell adhesion to bundles

For the mechanical testing and cell seedability testing, control samples were used from bundles and sutures prepared by VitaThreads. All additional bundles and sutures tested were produced by the design team's prototype. These three tests were chosen because they offered insight about how effectively the prototype was able to fulfill the objectives and functions identified for the design.

### 5.1 Mechanical Testing Results

In order to determine the mechanical properties of the bundles the team's prototype produced, the team conducted uniaxial loading testing on samples and compared the results with the preliminary testing done on mechanical testing performed on VitaThreads bundles. The team used the same protocol for the testing as previously outlined in 4.5.1 Mechanical Testing Results; the full protocol for the testing can be seen in Appendix C: Instron Testing Protocol for Microthread Bundle. The team used six samples from bundles produced by the prototype. During the testing, one sample broke; the remaining five samples were used testing to failure using an Instron Eletropuls e1000 machine. The team measured and calculated the mean diameter ( $\mu\text{m}$ ), gauge length (mm), YS (MPa), UTS (MPa), FS (mm/mm), and  $E$  (MPa). The mean and standard deviation for each property were calculated. Table 7 below shows the mean and standard deviation for all of the measured and calculated results for the mechanical testing.

Table 7: The mean and standard deviation for the two sample sets for all of the measured and calculate mechanical and physical properties.

	MQP Mean $\pm$ SD	VitaThreads Mean $\pm$ SD
YS (MPa)	0.20 $\pm$ 0.05	0.39 $\pm$ 0.19
UTS (MPa)	0.54 $\pm$ 0.18	1.066 $\pm$ 0.68
FS (mm/mm)	1.00 $\pm$ 0.43	1.33 $\pm$ 0.33
E (MPa)	0.27 $\pm$ 0.16	0.41 $\pm$ 0.17
Diameter ( $\mu\text{m}$ )	704.59 $\pm$ 55.5	488.94 $\pm$ 150

The average diameter of each sample can be seen below in Figure 14. The range of values for the prototype samples is smaller than the range for the VitaThreads samples.

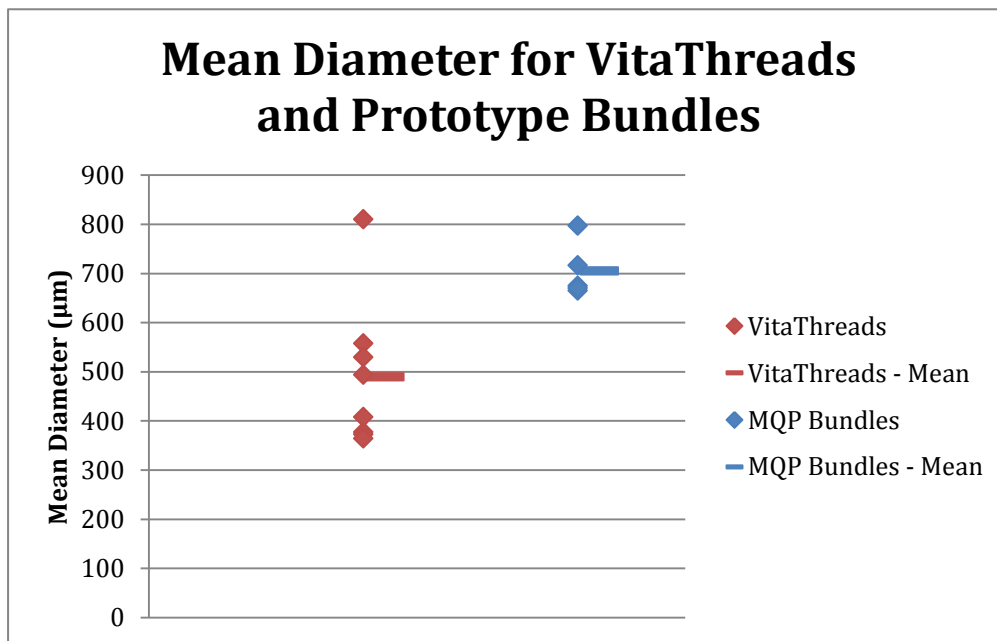

Figure 14: The calculated mean diameter for each sample and the mean and standard deviation for VitaThreads and prototype produced bundle samples.

Because of the application of these sutures in the heart, the team identified as most important mechanical properties as YS and UTS. Below in Figure 15 shows the calculated YS for each sample from the two testing sessions as well the mean and standard deviation for each sample set.

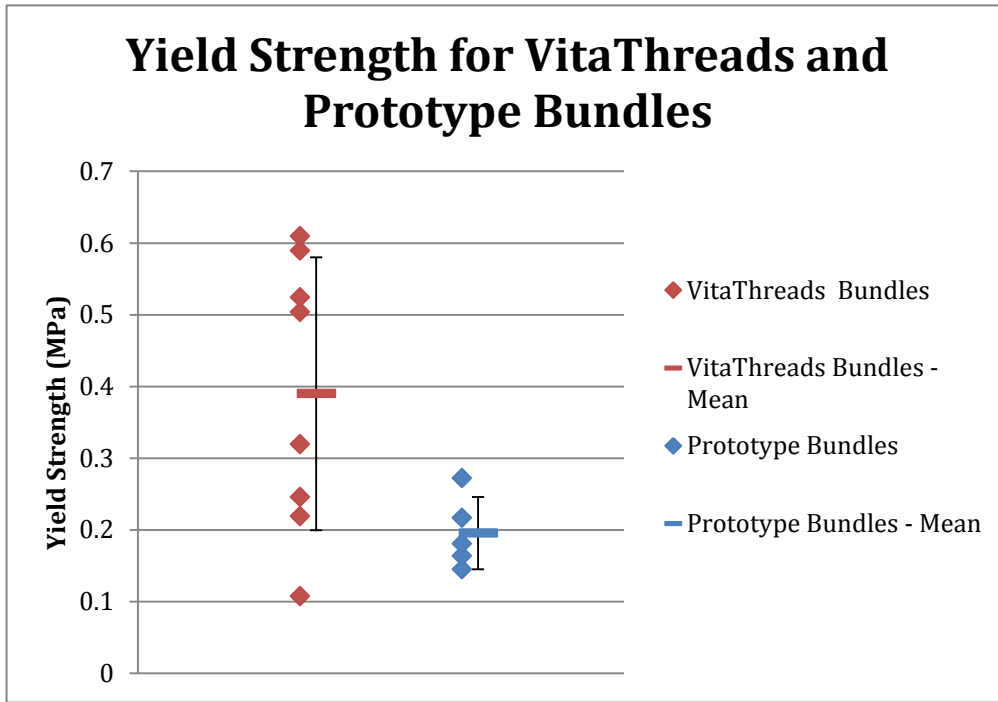

Figure 15: The calculated yield strength (YS) for each sample and the mean and standard deviation for VitaThreads and prototype produced bundle samples.

Figure 16 below shows the calculated UTS for every sample as well as the mean and standard deviation for each set of samples.

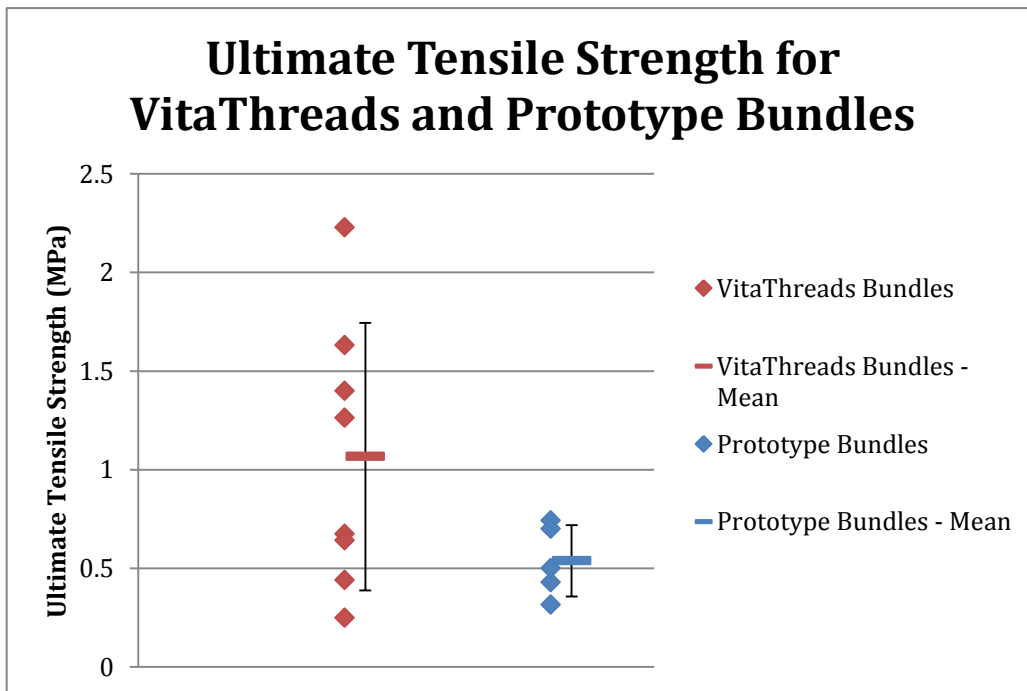

Figure 16: The calculated ultimate tensile strength (UTS) for each sample and the mean and standard deviation for VitaThreads and prototype produced bundle samples.

The team also compared the calculated  $E$  values for the two sample sets. Figure 17 below shows the calculated  $E$  for each sample from the two testing sessions as well the mean and standard deviation for each sample set.

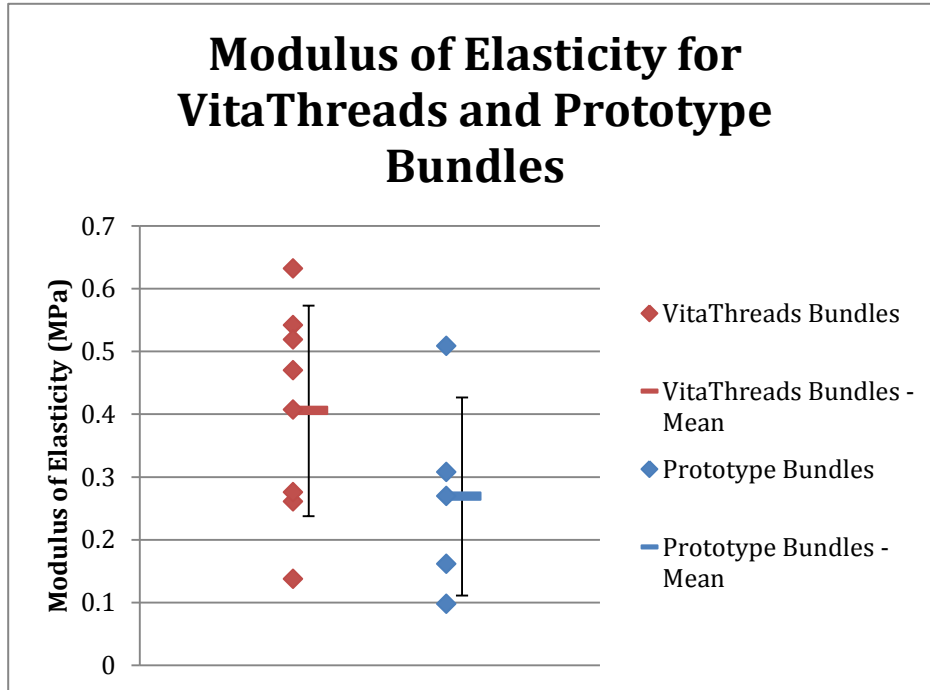

Figure 17: The calculated modulus of elasticity ( $E$ ) for each sample and the mean and standard deviation for VitaThreads and prototype produced bundle samples.

## 5.2 Cell Seedability Testing Results

The team conducted testing to determine if the prototype produced bundles that were able to seed cells as effectively as the current VitaThreads bundles. The team prepared 3 samples from prototype produced sutures and compared them to 4 VitaThreads samples. These samples were prepared in bioreactor tubing and sterilized using ethylene oxide gas. The sterilized samples were then injected with 1cc of hMSCs at a concentration of 100,000 cells/100 microns according to the protocol found in Appendix E: Protocol for Seeding Fibrin thread bundles with hMSCs using Rotator. The cells were passaged to the correct concentration according to the protocol found in Appendix D: Cell Culturing and Media Production Protocols. The seven samples were then set in a tube rotator and set in an incubator for 24 hours. After 24 hours, the samples were then prepared for staining and cell counting. Two methods for these were used for cell counting, staining and CyQUANT.

For the first method, Phalloidin and Hoescht stains were applied to the samples according to the protocol found in Appendix F: Staining Protocol. The samples were imaged using the Leica DM LB2 microscope at both 5x and 10x. Using ImageJ, the images were merged to show both the Phalloidin and Hoescht stains. The results of the staining method did not show any cell adhesion to the prototype produced bundles samples. Inconsistent cell adhesion was found on the VitaThreads samples. This cell adhesion inconsistency can be seen by the lack of green stain (from the Phalloidin stain) on the left side of the bundle, seen below in Figure 18.

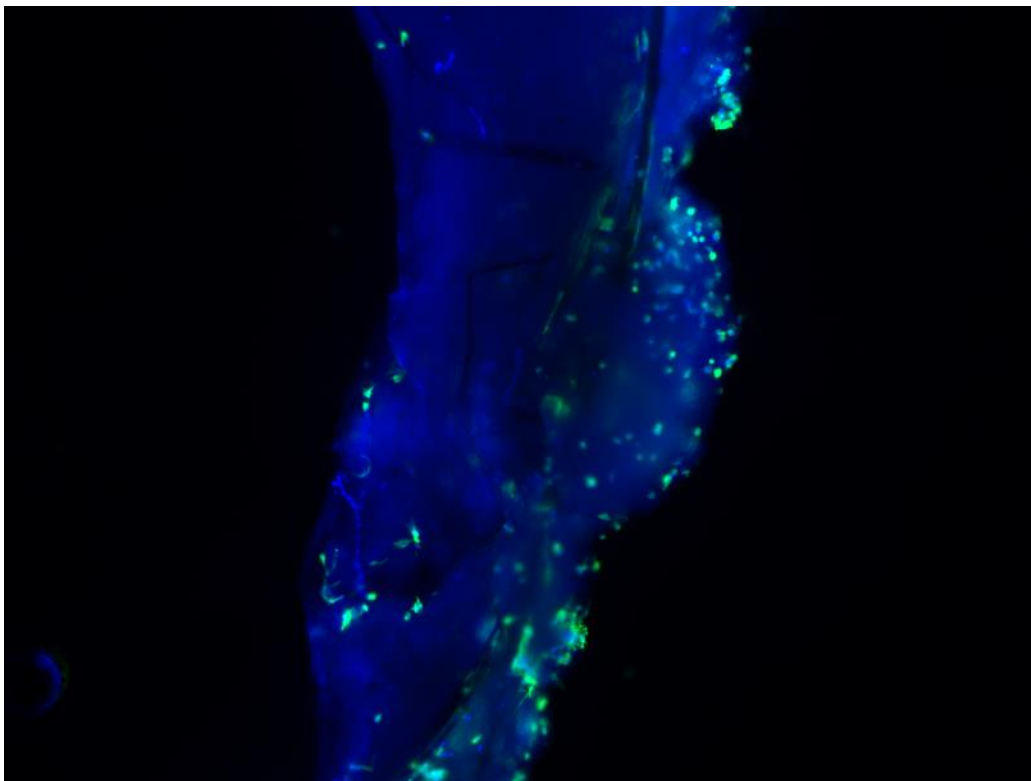

Figure 18: VitaThreads bundle sample with Phalloidin and Hoescht stain at 5x magnification.

The second method for cell counting was a CyQUANT DNA assay. A complete protocol for this method can be found in Appendix G: CyQUANT DNA Assay. From this assay, limited numbers of cells were found on both the prototype and VitaThreads samples. The averages number of cell found on the sutures can be seen below in Table 8.

Table 8: Average number of cell on sutures per cm for prototype and VitaThreads samples.

Sample	Average number of cells on suture/cm
--------	--------------------------------------



<b>Prototype</b>	629.85
<b>VitaThread</b>	777.04

### 5.3 Consistency Testing Results

The team also conducted consistency testing on the prototype produced bundles. The team used one dyed thread, dyed using trypan blue, in a 12-thread bundle. The sample was then imaged using the Amscope 1N300TB microscope in Salisbury Labs at both 5x and 10x. An examples image of a bundle can be seen below in Figure 19.



**Figure 19: A sample bundle being imaged at 5x under the microscope for twist consistency testing.**

Eight measurements were made over the length of the sample. Each measurement consisted of the amount of twists of the dyed thread counted along a length of 4 mm. A full protocol for this experiment can be found in Appendix H: Consistency testing. The mean number and standard deviation of twist per cm per sample was then calculated. Figure 20 below shows the measurements of the frequency of twist in the samples. The mean and standard deviation were calculated to be  $1.65 \pm 0.5$  twists per cm per bundle.

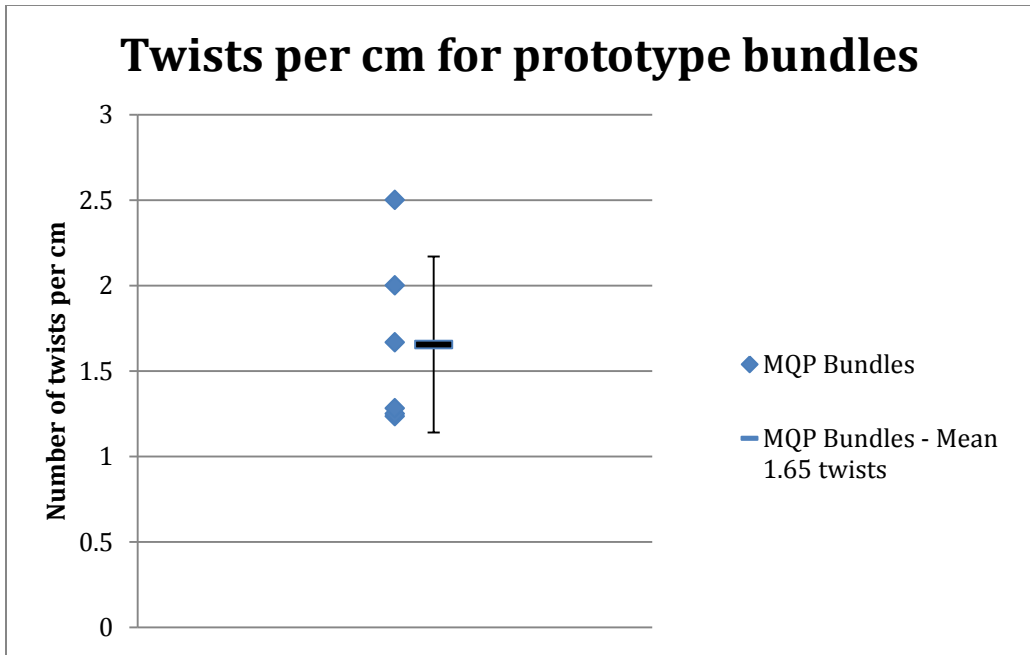

Figure 20: Results of the consistency testing showing number of twist per cm for prototype produced bundles.

## Chapter 6: Discussion

Once the completed prototype was used to create bundled threads, the bundles were subjected to different validation testing procedures to examine their properties. Separate bundles were set aside for each of the different validation testing that was completed, with tests focusing on the mechanical properties, consistency, and cell seedability. It was ensured that different bundles were used for each test, such that the results of one test would not be affected by the rigors of the other tests. For mechanical properties, bundles were subjected to uniaxial tension testing, stretched to their point of failure. Cell seedability was to be tested by seeding equine mesenchymal stem cells (eMSCs) on two sets of sutures. One set was produced by our device and the other from VitaThreads. These samples were then incubated for 24 and then counted. To check the consistency of the other samples bundled by the prototype, one out of the twelve microthreads was dyed to examine the thread's twists throughout the sample.

### 6.1 Bundle Mechanics Testing

From the data, it can be seen that the mean values for the mechanical properties of the device bundled samples are lower than the samples bundled by hand, and the standard deviations are also generally lower for the device bundled samples. Using a t-test with a p value of  $<0.05$  for statistical significance, measured with p values were found to be 0.05, 0.12, and 0.17 for the ultimate tensile strength, failure strain, and modulus of elasticity, respectively. It can be said that null hypothesis that each pair is comprised of different data sets is accurate for the mechanical properties.

For the standard deviation values, there was a 74%, 73%, 6%, and 63% reduction in the standard deviation for the yield strength, ultimate tensile strength, modulus of elasticity, and average diameter, respectively. For the standard deviation of the failure strain, there was an increase of 32%. This shows that despite a statistically lower mean value between the data sets, the lower standard deviation implies that there was a smaller spread in the mechanical properties of the prototype samples, suggesting a more consistent microthread bundle.

For the mechanical properties, we were willing to accept a slight loss in the strength of the bundle if it resulted in an increase in the consistency of the bundle in terms of itself

and overall bundle production. The data suggests that this objective was met, as there was unfortunate mechanical property loss, but there was also a decrease in the standard deviations of the device bundled samples, suggesting an increase in consistency within a bundle, and across different bundles. However, there is also the possibility that the change in standard deviation could have resulted from the smaller sample size of bundle sections from the device.

The loss of mechanical properties may further exacerbate the problem of sutures breaking at the eye of the needle during surgery, but the device has been designed such that the concern could be alleviated through other means. The ability for greater numbers of threads, 24 individual threading channels, allows for a greater number of threads to be evenly bundled for an ending suture of overall increased strength. In addition, the setup of the device that controls the ratio of twists to unit length is consistent across different thread counts, allowing continued consistency across bundles of different sizes.

## 6.2 Cell Seedability Testing

In order to ensure that the automated bundling did not significantly impact the bundle's ability to be seeded with cells, testing was done to examine the adhesion of the cells to the microthreads. To prepare the bundle, it was first threaded through a surgical needle and twisted to form a suture, and then stored inside bioreactor tubing to be sterilized using ethylene oxide gas. After sterilization, the sutures were washed with PBS and then cultured in approximately 100  $\mu$ l of cell media, at a concentration of 100,000 cells per 100  $\mu$ l, and then the sutures were left to seed for a 24 hour period. The cells adhered to the samples were then counted using two different methods.

Due to an unexpected complication, the samples did not receive the approximate amount of CO<sub>2</sub>. Due to limitations with time and samples, these samples were rinsed of cell media and reused for a second run of the experiment. This resulted in the samples being hydrated for over 48 hours. From the staining and the CyQUANT assay, all of the samples had little to no cell adhesion. This was believed to be related to the change in the protocol and the extended hydration period. The relatively close values of average cells per cm for the sutures from CyQUANT assay for the two sample sets suggest that the prototype samples behaved similar to the VitaThreads under these super hydrated conditions.

### 6.3 Consistency Testing

To examine the individual thread consistency within the device manufactured bundles, threads were dyed and examined with a microscope. After dyeing a single thread with trypan blue and operating the bundling device as normal, the resulting bundle was allowed to dry out and then placed on a slide and examined under a microscope. This allowed the path of the single dyed thread to be examined in depth, to view and measure the amount of twists that the single thread made in a given length.

The design team measured the number of twists per cm of the bundles made by the prototype. The prototype bundles had a mean of 1.65 twists per centimeter with a standard deviation of 0.5. VitaThreads bundles were reported to have an average of 1.5 twists per centimeter. As seen above in 5.3 Consistency Testing Results the majority of the twist data fell within one standard deviation of the results. Having a low standard deviation and a mean close to that of VitaThreads specification of 1.5 twists per cm shows that the prototype was successful in producing highly consistent bundles.

### 6.4 Impact Analysis

This design is a prototype, but still has the potential to impact society. The main function of this device is to produce microthread bundles for small-scale, laboratory production. However, the potential for microthreads to become mass-produced is possible, and the device represents the first automated stretching system for fibrin microthreads. This device represents a critical step in the full automation of microthread production. The following is the team's analysis of the societal impact of the device.

#### 6.4.1 Economic impact

Since our device is designed for laboratory production it has little to no economic influence. This device is designed to twist fibrin microthreads into bundles, which will then be used to deliver cells to target areas. It is not intended for mass production and therefore, our device would not affect the economy of everyday living.

#### 6.4.2 Environmental Impacts

The materials that the team is using to build the device are non-renewable and non-biodegradable. The parts are comprised of a variety of metals and plastics. Therefore, the

production of this design would have a negative impact on the environment. Additionally, improper disposal of the parts for this design would have a negative impact on the environment.

#### **6.4.3 Societal Influence**

This bundling device will not have any societal influence on the general population. The device is only designed to twist microthreads into bundles. This process is designed to be performed within a clean laboratory environment by trained lab technicians, and thus the design will not to be used by the general population. Even in production, sales, or marketing, it is expected that mostly medical professionals or companies to be attracted to our device.

#### **6.4.4 Political Ramifications**

There are no influences that the microthread bundling device would have on the global politics. The techniques and uses of microthread sutures are still in a research and development stage and are only used in very specific facilities, such as Vitathreads. Thus, the device will not have an impact on the global market, nor would it have any influence on the cultures of other countries.

#### **6.4.5 Ethical Concerns**

While our design does not directly involve the seeding of cells onto the threads, the larger production of fibrin microthread sutures involves the seeding of stem cells for targeted cell delivery. The stem cells being used are not embryonic stem cells, though the use of stem cells is still a highly debated topic due to the ethical concerns surrounding the retrieval of stem cells.

#### **6.4.6 Health and Safety Issue**

This device is part of a larger operation to produce fibrin microthread sutures for cell delivery. Since this operation is not FDA approved yet, there are health and safety concerns for the materials being used in this operation. Since biological materials are being used to produce the microthreads, these materials need to be well regulated and used properly in order to ensure there are no health and safety issues with this device.

#### **6.4.7 Manufacturability**

As of now, our prototype has many parts that we had to find and put together, such as rods, gears, and pieces that are rapid prototyped. In terms of complexity, our model is not very complicated, but it is not easily built. Since there is not a large market for this device, we did not prioritize our model to be easily reproduced.

#### **6.4.8 Sustainability**

Since our device is only mechanical at the moment, it is powered by human energy using a hand crank system and does not require any electrical energy input. Thus, the device will run off renewable energy and will not negatively impact the environment in this regard.

## Chapter 7: Final Design and Validation

The problem at hand was to design and build a suture maker that consistently produced a bundle of fibrin microthreads that could be easily interfaced with a surgical needle and then seeded with stem cells. The current method used by VitaThreads for bundling is by hand and a lot of the variances in properties between bundles are attributed to this factor. The need for the suture maker to limit those factors ultimately led to an exceedingly reproducible bundle. The individual microthreads are extremely fragile and must be hydrated throughout the bundling process in order to prevent fracture and ensure adhesion between threads. The design of the suture maker must also allow for a varying number of threads to be bundled as requested by the client.

Once the design team had reached a decision on the final design for the suture maker through initial concept validation testing, it was important to conduct machine validation and bundling validation on the final design. Machine validation would serve to affirm that all components of the machine were performing to ensure a consistent twist within the final bundle. Bundle validation would serve to confirm that the suture maker produced bundles that were more consistent than manually produced bundles while maintaining mechanical properties. The controls that were used to test the bundles created by the suture maker were bundles made by VitaThreads and the design team. After successful validation of the design, the team was able to determine how the suture maker had improved the bundling process.

The MQP project was to be completed and all objectives met within 7 weeks. The design team first made Gantt chart, as seen below in Figure 21 to breakdown the work in to weekly goals. This allowed the team to orderly complete the project within the allotted time.



	Week 2	Week 3	Week 4	Week 5	Week 6
Biweekly Writing					
Testing and Analysis Protocols					
Instron Testing (Current Sutures)					
Cell Culture					
Brainstorming Design					
Conceptual Designs					
Evaluation Design Alternatives					
CAD Modeling of Design					
Build Prototype					
Prototype Testing					
Final Report					
Final Presentation					

Figure 21: The design team's Gantt chart for the project.

## 7.1 Machine Validation

The design team arrived at a final decision to use gears and pulleys to create a twisted braid after several initial concept experiments. It was important to the team that this design allowed the threads to be bundled with a higher consistency between bundles and proper thread hydration without any human interaction with the individual threads.

### 7.1.1 Thread Path

In order to ensure that the threads did not interact with each other a set path was developed for them. Three discs with up to 24 apertures were created and placed on a center axial as guiding holes for this path. The 24 apertures allowed for the suture maker to have a variable amount of holes and allowing different number of threads to be bundled.

The discs were drawn using Solidworks and rapid prototyped for testing. Several different designs were created until arriving at our final disc design; Figure 22 below shows the final disc design.

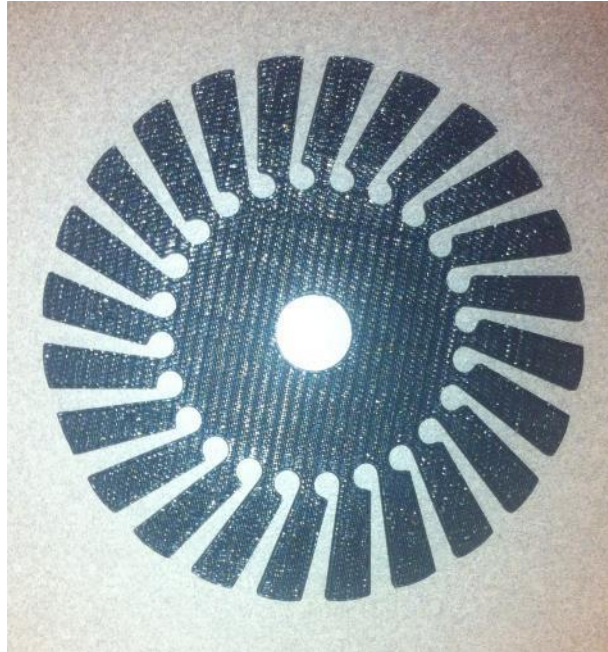

Figure 22: The final design for the threading discs.

The initial discs were similar as they had holes, but the loading time proved to be tedious and long. In order to cut time out of the bundling process and make the process more user friendly, angled slits were cut into the sides of the discs towards each aperture. The number of apertures was increased from 12 to 24 to allow more threads to be bundled. Also, the initial disc designs were white that made it difficult to see the threads, the team made the final discs black as to create a contrast and make the threads more visible during loading. Table 9 below summarizes the data from the disc testing.

Table 9: Results of different threading discs testing.

Test	Disc Type	Success/Failure
1	12 Hole Rapid Prototyped	Success
2	6 Hole Rapid Prototyped	Failure
3	12 Hole Lexen	Failure
4	24 Hole Rapid Prototyped	Success

### 7.1.2 Lifting System

After the development of the discs, the team had to decide on what way the threads would be raised through the disc's apertures. The team ran conceptual tests on a screw system but decided that a pulley would be more efficient. In order to have the threads moving vertically while rotating and twisting, a pulley was placed above the discs and attached to the same crank arm that controlled the rotation of the discs. The crank arm turns the discs together as one and also activated the pulley that lifted the threads through the discs as the bundle was created. Table 10 below is a summary of the conceptual testing done in search of the lifting mechanism.

Table 10: Results of different lifting system testing.

Test	Lifting Mechanism	Success/Failure
1	Screw System	Failure
2	Pulley	Success

### 7.1.3 Guiding Mechanism

With the development of the pulley lifting system the design team noticed that there were some inconsistencies at the initial point of twisting. The team attributed this to variability to the vertical point where the initial twist occurred. The issue seen during testing was that there was no specific point at which the threads would twist. In order to fix this a guiding mechanism was made and placed just above the top disc to provide the proper guidance and set a fixed point where each twist would occur. The guidance hole above the top disc allows the threads to converge at the same point and ensure the same twisting angle between each twist throughout the bundle. Several tests were conducted to find the final design of guidance hole. A summary of our data can be seen below in.

Table 11.

**Table 11: Results of different guiding mechanism testing.**

<b>Test</b>	<b>Guidance Hole</b>	<b>Success/Failure</b>
<b>1</b>	Square shaped	Failure
<b>2</b>	Zip-Tie	Success
<b>3</b>	Circular	Success

#### 7.1.4 Hydration

In the bundling process the hydration of the threads is a very important step. The threads were hydrated prior to bundling and then maintained as the twisting occurred. The adhesive nature of the fibrin allows them to bond to each other and thus creating a bundle. The team tested a number of different hydrating systems as find the most efficient means of hydration. Hydration was conducted using a water dropper; the current method used by VitaThreads, a mist was also used to hydrate threads via spray bottle. A trough system was also used; straws were cut vertically into a “half-pipe” shape and then fitted through the disc apertures. The threads hydrated using the trough system and spray system were both effective means for hydrating the threads during bundling. The team also attempted to use water as we tested the viability of a humidifier, below Table 12 summarizes the results of the hydration methods highlighted above throughout the testing period.

**Table 12: Results of different hydration method testing.**

<b>Test</b>	<b>Hydration Method</b>	<b>Success/Failure</b>
<b>1</b>	Water Droplets	Failure
<b>2</b>	Spray Bottle	Success
<b>3</b>	Humidifier	Failure
<b>4</b>	Troughs	Success

## 7.2 Bundle Validation

In order to determine the consistency of the bundles produced by the prototype, the team used a series of bundles validations tests. The team's bundle validation included mechanical analysis and structural analysis through the testing detailed in Chapter 5 and 6. The team determined that these tests were the best options for validating the consistency of the bundles due to the time constraints of this project. These tests were chosen because similar methods have been used in past studies to better understand the properties of microthreads and are similar to quality control methods currently used by VitaThreads.

### 7.2.1 Mechanical Analysis

After the completion of Instron testing it was evident that the design team accomplished the objective of creating a suture maker that made consistent bundles of similar prosperities. The average YS and UTS seen earlier in Chapter 5: Design Verification of the prototyped produced bundles proved to have lower average values but ultimately had much lower standard deviations implying that the threads had less variance due to the low standard deviations. The data from the Instron testing suggests that the suture maker was successful in achieving Functions 1 and 11 producing a consistent bundle and not significantly effecting mechanical properties which can be seen in 3.4.1 Functions.

### 7.2.2 Structural Analysis

During the prototype testing of the project many bundles were prepared by the MQP and assessed for structural analysis. During hydration testing and Instron testing imaging was done on the bundles. Using the MatLab program in the Gaudette lab several images were assessed for wet diameter. Out of this data an interesting trend arose. The fibrin microthread bundles produced by the design team proved to have an overall higher wet diameter and a much smaller standard deviation than those prepared by VitaThreads. Bundles prepared by the prototype had an average wet diameter of  $704.58 \pm 55.4$  micrometers and the bundles prepared by VitaThreads had an average wet diameter of  $488.94 \pm 150$  micrometers. The prototype produced bundles of great diameter with a much lower deviation between bundles. The small standard deviation seen in the wet diameter

can be attributed to the removal of human role in bundling and indicates that the bundles made by the prototype were more consistent.

Through the consistency testing detailed previously, the team determined that the prototype was able to produce consistency bundles that met the specification of 1.5 twists per cm of the design.

### 7.3 Final Design

After completing validation testing on the machine parts and bundles produced by the prototype the design team built in SolidWorks a model of the final design. The final design was developed as an improved version of the prototype with parts that would address several problems seen throughout the testing period. An emphasis was placed upon creating a prototype that was constructed out of standard parts, and was simpler and safer to operate.

For the rotating disks that guided the threads, the final design included a total of 24 apertures to allow a variable number of threads when bundling, while a guiding hole suspended above the uppermost disk allowed all the threads to converge at the same point. The pulleys placed above the rotating discs allowed the threads to be lifted directly vertically at a controlled rate, as they were hydrated with distilled, deionized water using a spray bottle. The pulley is ultimately able to be raised a distance greater than the fourteen inches accommodated for the disk system, allowing for a greater length of threads to be operated with.

Mechanically speaking, the LEGO® prototype rotated the disc shaft with an array of gears. Appendix I: Initial Prototype Images offers more images of the initial prototype designed from LEGOs. In order to simplify the mechanics and create a smoother machine the team used a mixture of gears and pulleys within the crank box. In Figure 23 below show the prototype with its array of gears and the final design with the changes. A full set of images of the second prototype built based off of this final design can be seen in Appendix J: Second Prototype Images.

In the final design, the inclusion of standardized gears and pulley systems allow for the parts to be alterable, leaving the potential for them to be changed out at later times. This would allow for a different ratio between the ninety degree miter gears, or the two

pulleys inside the box, for an adjustable twist per unit length ratio. Further, the mechanisms were contained within the polycarbonate housing, serving to protect the gears and pulleys from damage, while protecting outside objects from being caught by the moving parts to increase the overall safety of the device for users

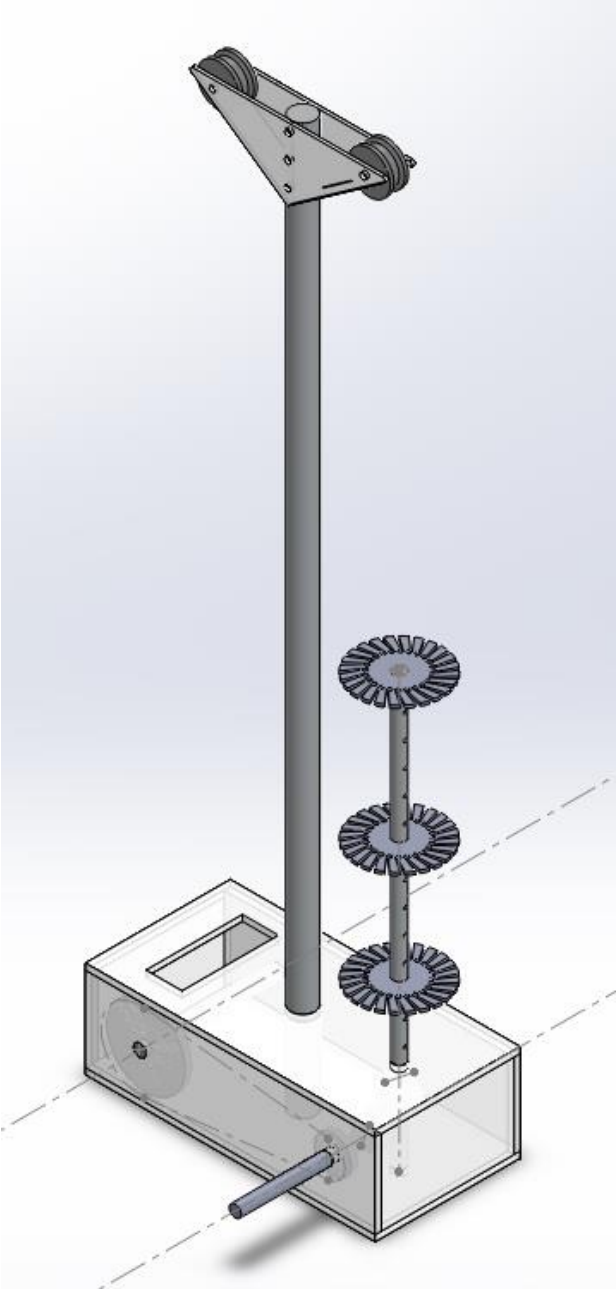

Figure 23: CAD model of the final design of the bundling device.

## Chapter 8: Conclusions and Recommendations

In review, the project and resultant design can be examined such that overall conclusions regarding the completed work can be drawn in reference to the outlined objectives. The primary goal of the entire project, the production of more consistent microthread bundles, resulted from the mechanical bundling of the final design. With respect to other properties of the bundles, it was seen that the mechanical properties were not significantly impacted, and the cell seedability exhibited adhesion of a similar magnitude on bundles produced through different methods. In addition, the device mechanics that maintain the amount of twists in a unit length of the bundle allows for the further removal of human variability in overall suture production, a goal desired by VitaThreads.

The results suggest that the threads produced by the bundling device have increased consistency throughout and across bundles, while maintaining acceptable mechanical properties. The prototype was designed and built to achieve the key functions of consistency and reproducible fibrin microthreads bundles through a simple uniaxial twisting motion. An initial prototype was developed and testing for proof of concept and was able to be used to produce bundles for bundle validation testing. From the testing done with the initial prototype, the team was able to improve upon the initial prototype and redesign using standardized parts with precise dimensions and measurements to improve on the quality of the entire process. Through the prototypes, the team was able to successfully achieve the bundling objectives for the design.

### 8.1 Recommendations

Through the testing of the initial prototype, the team developed several alterations that could be applied to future prototypes and designs for the device, but many of these could not be completed due to time and budget constraints on the project. For further research and testing regarding the construction and layout of the simple twist system, considered aspects that could be improved upon include the pulley and in-box belt systems, a variable diameter spool, and an overall more accessible box. One recommendation the team has for improving the design would be the implementation of an accurately sized O-ring for the pulleys inside of the box. An additional recommendation to



increase the variability of twisting is the addition of similar pulleys on the spool wheel to add a variety in available diameters. This would in turn change how quickly the bundle is pulled upwards and therefore change the frequency of the twists in the bundle. The team also suggests the addition of a smaller diameter feeder loop to increase the effectiveness of this guiding system. Lastly, the team suggests the addition of a hinge of similar mechanism to the closed gear box system to allow for easier maintenance and modifications.

For studies conducted on the bundles produced by the device, it is recommended that more data is acquired on the hydration methods compatible with the system, the mechanics and consistency of additional bundles, and an in-depth examination of the bundling mechanism. Due to the time and material constraints of the project, the team was limited to small sample sizes for all of their testing of the prototypes and design mechanisms. The design was greatly improved throughout the design process, and stands to further standardize the bundling mechanism with appropriate changes. Potential topics of further research could focus on larger sample sizes mechanics and cell seedability testing, and analysis of the effects of different angles the threads are bundled at. The team also suggests additional research be done on the different application methods and time durations of hydration as well as the further developing of the hydration troughs.

Moving forward with the system, larger scale improvements to the consistency of the produced bundles, or an increase of automation that removes the hand crank and human feeding, could be applied for producing bundles in a large scale manufacturing situation. Alternatively, research could be shifted to examine the potential changes to bundles produced through an altered twist or braiding mechanism, to evaluate the effect of physical arrangement of threads on the properties of the overall suture.

## References

- Altman, G. H., Diaz, F., Jakuba, C., Calabro, T., Horan, R. L., Chen, J., et al. (2003). Silk-based biomaterials. *Biomaterials*, 24(3), 401-416.
- Barbash, I. M., Chouraqui, P., Baron, J., Feinberg, M. S., Etzion, S., Tessone, A., et al. (2003). Systemic delivery of bone marrow-derived mesenchymal stem cells to the infarcted myocardium feasibility, cell migration, and body distribution. *Circulation*, 108(7), 863-868.
- Barry, F. P., & Murphy, J. M. (2004). Mesenchymal stem cells: clinical applications and biological characterization. *The international journal of biochemistry & cell biology*, 36(4), 568-584.
- Bartholomew, A., Sturgeon, C., Siatskas, M., Ferrer, K., McIntosh, K., Patil, S., et al. (2002). Mesenchymal stem cells suppress lymphocyte proliferation in vitro and prolong skin graft survival in vivo. *Experimental Hematology*, 30(1), 42-48.
- Burkhard Wulforst, T. G. (2006). *Textile Technology*. Cincinnati, Ohio: Hanser Gardner Publications, Inc.
- Chen, S.-l., Fang, W.-w., Ye, F., Liu, Y.-H., Qian, J., Shan, S.-j., et al. (2004). Effect on left ventricular function of intracoronary transplantation of autologous bone marrow mesenchymal stem cell in patients with acute myocardial infarction. *The American journal of cardiology*, 94(1), 92-95.
- Cornwell, K. G., Lei, P., Andreadis, S. T., & Pins, G. D. (2007). Crosslinking of discrete self-assembled collagen threads: Effects on mechanical strength and cell-matrix interactions. [Article]. *Journal of Biomedical Materials Research Part A*, 80A(2), 362-371.
- Cornwell, K. G., & Pins, G. D. (2007). Discrete crosslinked fibrin microthread scaffolds for tissue regeneration. *Journal of Biomedical Materials Research - Part A*, 82(1), 104-112.
- Cornwell, K. G., & Pins, G. D. (2010). Enhanced proliferation and migration of fibroblasts on the surface of fibroblast growth factor-2-loaded fibrin microthreads. *Tissue Engineering - Part A*, 16(12), 3669-3677.
- Crigler, L., Robey, R. C., Asawachaicharn, A., Gaupp, D., & Phinney, D. G. (2006). Human mesenchymal stem cell subpopulations express a variety of neuro-regulatory

- molecules and promote neuronal cell survival and neuritogenesis. *Experimental neurology*, 198(1), 54.
- De Bari, C., Dell'Accio, F., Vandenabeele, F., Vermeesch, J. R., Raymackers, J.-M., & Luyten, F. P. (2003). Skeletal muscle repair by adult human mesenchymal stem cells from synovial membrane. *The Journal of cell biology*, 160(6), 909-918.
- Grasman, J. M., Page, R. L., Dominko, T., & Pins, G. D. (2012). Crosslinking strategies facilitate tunable structural properties of fibrin microthreads. [Article]. *Acta Biomaterialia*, 8(11), 4020-4030.
- Greenwood, M. (2006). New large diameter synthetic rope testing yields high strength and performance. Anacortes: Cortland Institute.
- Hou, D., Youssef, E. A.-S., Brinton, T. J., Zhang, P., Rogers, P., Price, E. T., et al. (2005). Radiolabeled cell distribution after intramyocardial, intracoronary, and interstitial retrograde coronary venous delivery implications for current clinical trials. *Circulation*, 112(9 suppl), I-150.
- Jones, John J. P. (1988). Patent No. US4774871 A. US.
- Laflamme, M. A., & Murry, C. E. (2011). Heart regeneration. *Nature*, 473(7347), 326-335.
- Li, Y.-S., Milner, P. G., Chauhan, A. K., Watson, M. A., Hoffman, R. M., Kodner, C. M., et al. (1990). Cloning and expression of a developmentally regulated protein that induces mitogenic and neurite outgrowth activity. *Science*, 250(4988), 1690-1694.
- O'Brien, J. S., Carson, G. S., Seo, H.-C., Hiraiwa, M., & Kishimoto, Y. (1994). Identification of prosaposin as a neurotrophic factor. *Proceedings of the National Academy of Sciences*, 91(20), 9593-9596.
- Page, R. L., Malcuit, C., Vilner, L., Vojtic, I., Shaw, S., Hedblom, E., et al. (2011a). Restoration of skeletal muscle defects with adult human cells delivered on fibrin microthreads. *Tissue Engineering - Part A*, 17(21-22), 2629-2640.
- Papyrus, E. S. S. (1994). Mechanical comparison of 10 suture materials before and after in vivo incubation. *Journal of Surgical Research*, 56, 372-377.
- Parekh, D., Carey, S., Gaudette, G. R., Pins, G. D., & Rolle, M. W. (2009). Design of a technique for rapid and uniform cell seeding on fibrin microthreads. Paper presented at the 2009 IEEE 35th Annual Northeast Bioengineering Conference. NEBEC 2009, 3-5 April 2009, Piscataway, NJ, USA.

- PMC, E. P. C. E. (2006). Human mesenchymal stem cell subpopulations express a variety of neuro-regulatory molecules and... - Abstract - Europe PubMed Central. [Comparative Study]. *Experimental Neurology*, 54-64.
- Proulx, M. K., Carey, S. P., Ditroia, L. M., Jones, C. M., Fakharzadeh, M., Guyette, J. P., et al. (2011). Fibrin microthreads support mesenchymal stem cell growth while maintaining differentiation potential. *Journal of Biomedical Materials Research - Part A*, 96 A(2), 301-312.
- Richardson, D. (1993). *Patent No. US525751 A*. USA.
- Simpson, D., Liu, H., Fan, T. H. M., Nerem, R., & Dudley, S. C. (2007). A tissue engineering approach to progenitor cell delivery results in significant cell engraftment and improved myocardial remodeling. *Stem Cells*, 25(9), 2350-2357.
- Torsvik, A., & Bjerkvig, R. (2013). Mesenchymal stem cell signaling in cancer progression. *Cancer treatment reviews*, 39(2), 180-188.
- Viju, S., & Thilagavathi, G. (2012). Fabrication and characterization of silk braided sutures. *Fibers and Polymers*, 13(6), 782-789.
- Wang, Y., Kim, H.-J., Vunjak-Novakovic, G., & Kaplan, D. L. (2006). Stem cell-based tissue engineering with silk biomaterials. *Biomaterials*, 27(36), 6064-6082.
- Yan, J., & Zhu, Q.-J. (2012). Research on tension control system of filament winding machine. Paper presented at the 2011 International Conference on Manufacturing Science and Technology, ICMST 2011, September 16, 2011 - September 18, 2011, Singapore, Singapore.

# Appendices

## Appendix A: Design Objectives Tree

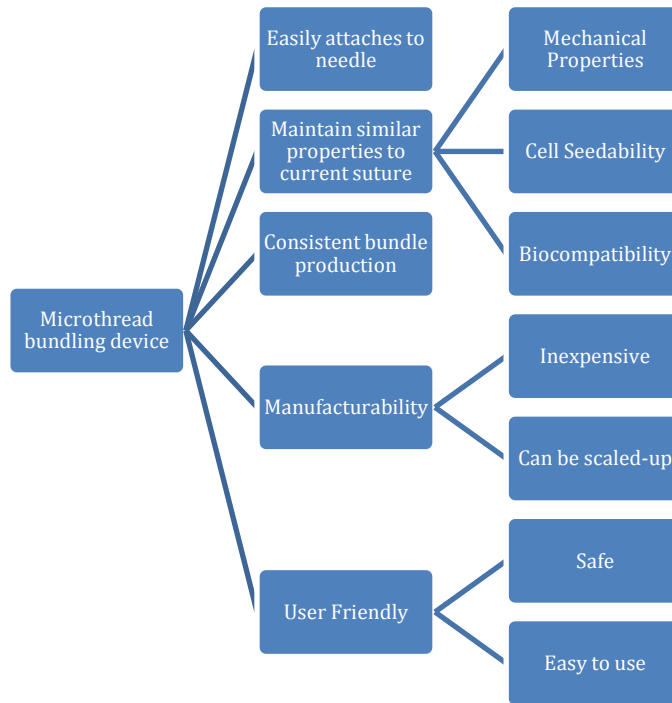

## Appendix B: Design Specifications

- Produce bundles that can be made into sutures of at least 4 cm in length
- Can bundle 1-24 microthreads
- Can bundle microthreads of approximately 12 inches in length
- Take a maximum of 30 minutes to produce a bundle
- Produce approximately 1.5 twists/braids per cm
- Allow thread to bend 90 degrees over 8 cm length
- Minimize exposed gears and sharp objects
- Bundle must be similar diameter to current handmade bundles
- Within two standard deviation to UTS of current bundles
- Within two standard deviation to YS of current bundles
- Maintain similar cell seedability to current sutures

## Appendix C: Instron Testing Protocol for Microthread Bundle

### Hydration

- Hydrate bundles in target solution. This should be done for at least 1 hour.
- While bundles are hydrating, prepare the Instron and microscope for testing.

### Imaging

- Prior to testing, take several 5x images of the thread bundle on the Gaudette Lab scope
  - a. Lay bundle on an uncharged microscope slide and image the bundle at 5x

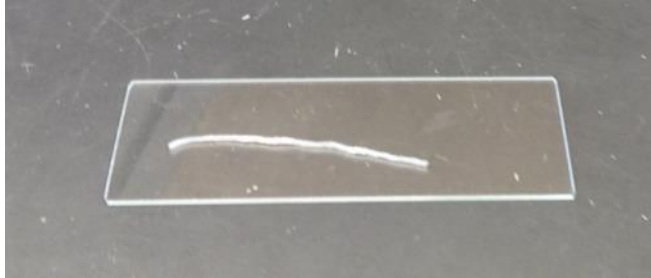

- b. Save pictures in a folder on the desktop being sure to name the files in the form Exp15xxx\_0001.tif etc.
  - c. When all images are taken, CUT and paste the image files onto the Gaudette lab drive: '\\research.wpi.edu\gaudettelab\Raw Data\Exp15000s\Exp15xxx\'
  - d. DO NOT LEAVE FILES ON THE SCOPE COMPUTER
- **After imaging, return the bundles to the hydration solution**

### Setting Up Instron Machine

- Set up the Instron for testing
  - a. CAREFULLY attach the 1N load cell to the Instron and plug it into the back
  - b. Turn on Instron controller
  - c. Log into Instron computer
  - d. Open Instron console
  - e. Calibrate the 1N load cell
  - f. Attach the right bundle grip to the load cell, balance the load cell (the grip can then be removed)
  - g. Open the Instron test panels
  - h. Open Bluehill
- Mount the bundle in the bundle grips
  - a. Lay bundle across grips

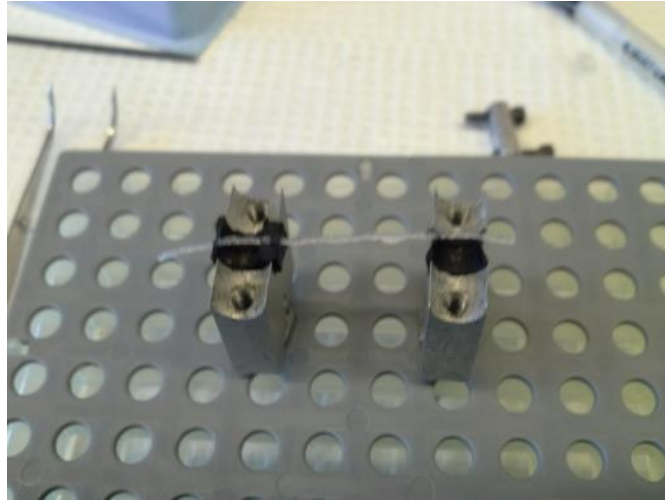

- b. Tighten one side of grips
- c. Tighten other side of grips

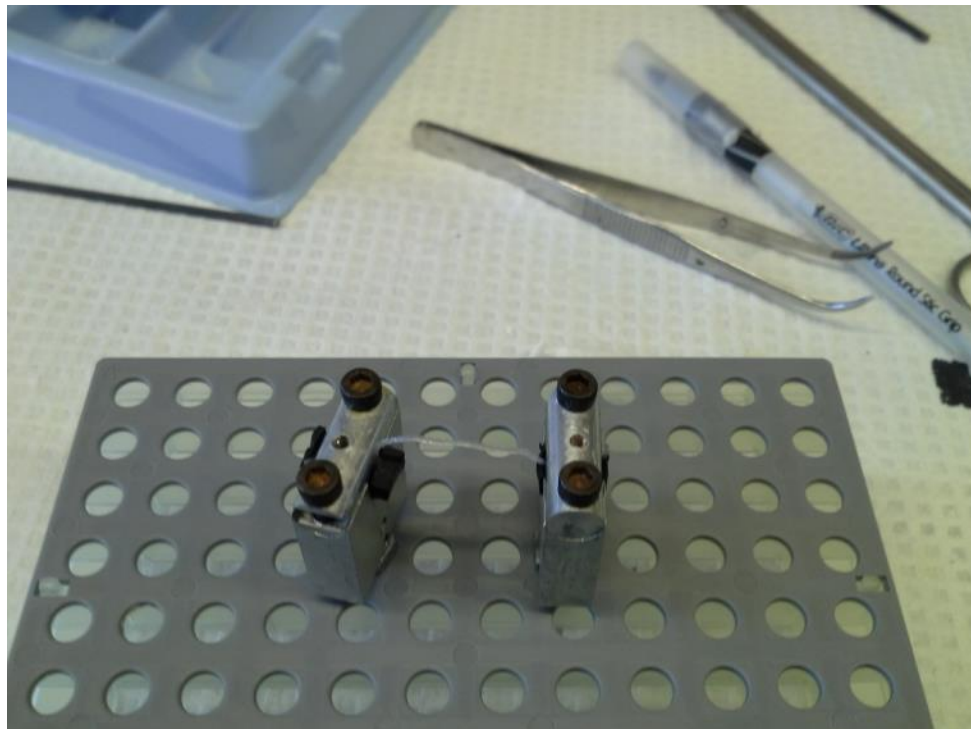

- d. Return thread and grips to hydration solution

### Initializing the Instron Software

- Load the Instron test file
  - a. In bluehill, go to Test, load the latest Fibrin bundle methods file.
  - b. Name the file with the current experiment number (Exp15xxx) and ensure that the instron is saving to the 'G:\Raw Data\Instron raw output' directory.



- c. Enter all pertinent information related to the current thread bundle. Make sure the specimen label is in the form: 'Exp15xxx'

### Loading Instron Machine

- Load the grips onto the instron

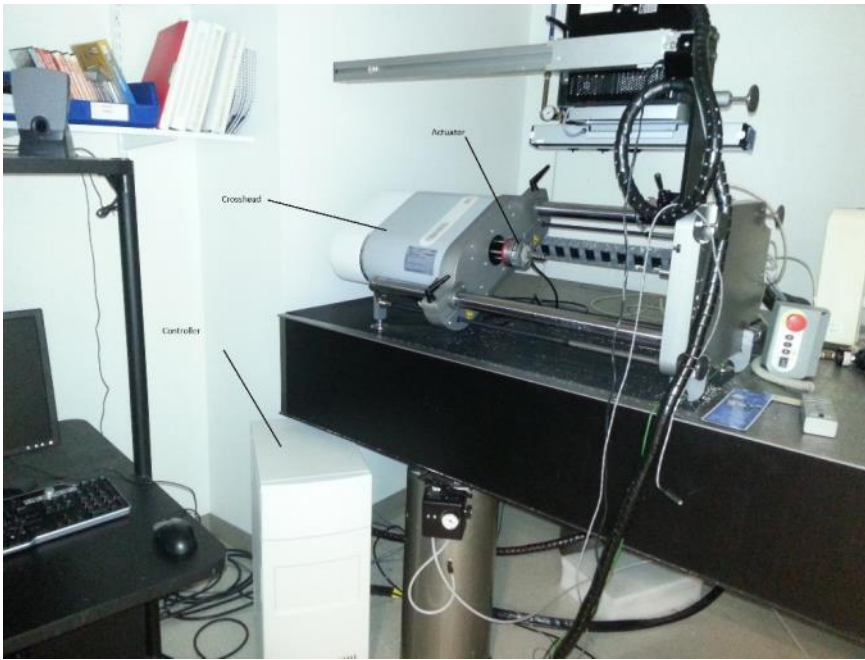

- a. Attach the correct instron grips on both sides
- b. Extend the instron actuator as far out as possible (Extension on test panel will read ~30mm)
- c. Move the crosshead to approximate the grip location with a thread loaded (This will take some practice/experience)

- d. CAREFULLY attach the right thread grip to the 1N load cell. Rest the left grip on the lower piece of the left instron grip

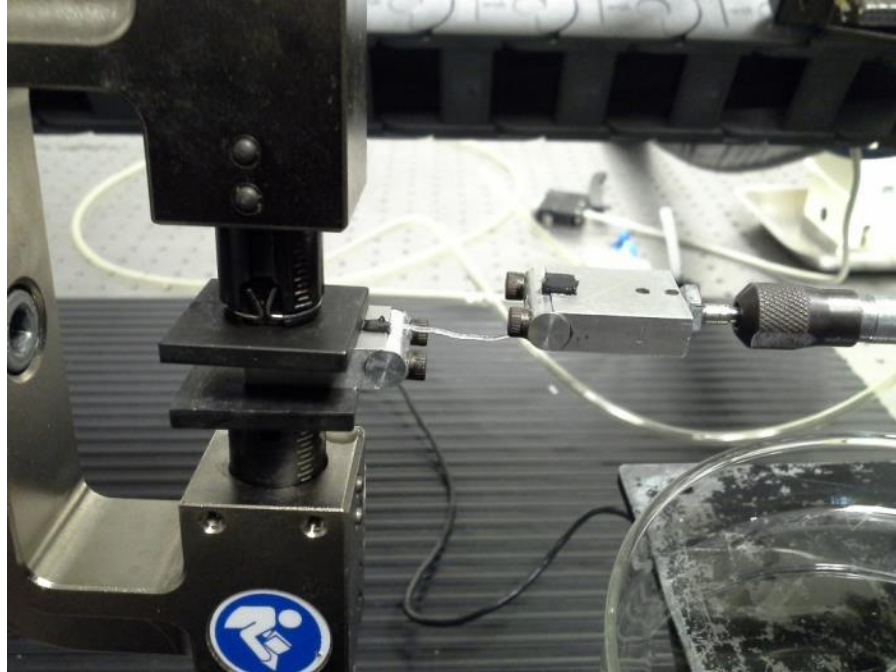

- e. Align the thread linearly in both the vertical and horizontal direction.
- f. Tighten the left side of the thread in the left instron grip
- g. Using the actuator, apply a 10 mN load to the thread. (The viscoelastic properties of the thread will dissipate this force over time, this will not affect results.)
- h. In bluehill, reset gauge length
- i. Measure and record the starting length in bluehill
- j. Rehydrate the thread using a transfer pipette
- k. Run the test

## Appendix D: Cell Culturing and Media Production Protocols

### **Materials:**

- Media and media supplements
  - DMEM basal media with high glucose, sodium pyruvate, phenol red, sodium bicarbonate
  - Fetal bovine serum
  - Glutamax (200 mM)
  - Penn-strep (100X)
- Trypsin (0.25% stock solution; prepare 0.05% working solution)
- Sterile 1X DPBS (without calcium and phosphate)
- DMSO (sterile)
- Sterile tubes and culture plates
- Incubator (5% CO<sub>2</sub>; 37°C)
- Biological Safety Cabinet (BSC)
- Water bath (37°C)
- Centrifuge
- Microscope
- Serological pipets
- Motorized pipet aid
- Vacuum trap
- Sterilized Pasteur pipets
- Hemocytometer
- Solvent resistant markers
- Spray bottle containing 70% ethanol
- Kimwipes
- Gloves

### **General Procedure:**

- Make sure all the materials used for cell culture are sterilized before use.
- Before and after use, wipe the hood surface with 70% ethanol.
- Wipe any non-sterilized material with ethanol before placing them in the hood.
- After using the hood, close the gate and turn on the UV light for at least 20 minutes

### **Passaging:**

1. Receive a 100mm plate of cells from instructor
2. Make sure the cells are there by looking at them under a microscope
3. Once the cells look to be about 70%-80% confluent, they are ready to be passaged
4. Take the complete media and trypsin out of the refrigerator and along with the DPBS, place them into the hood, making sure to wipe the bottles with ethanol beforehand

5. Carefully aspirate the medium with the pasteur pipet and the vacuum tube by tilting the plate so that the medium flows into a corner, try not to scratch the bottom of the plate where the cells are located.
6. Wash the plate with 5ml DPBS by pipetting the PBS onto the side of the plate, so that the cells are not disturbed. Swirl the DPBS around the plate slowly and then aspirate.
7. Add in 1x trypsin EDTA (~3 mL for a 100 mm plate) and swirl it around the plate. Put the plate back into the incubator for 5-10 min to allow for trypsinization.
8. Take the plate back to the hood and add 2 mL of complete media and pipette up and down to break up clumps. Transfer the media into a 15 mL conical tube.
9. Take the tube and spin the cells down in a centrifuge at 10,000 RPM for 5-10 minutes.
10. Take the tube back to the hood and aspirate out the media, be careful not to suck up the cells.
11. Resuspend the cells in 5ml fresh complete media, pipette up and down to break clumps.
12. Obtain a new plate a write your name, the cell type, date, and passage number.
13. For our purposes, we used a 1:20 dilution so that is 0.250 mL of the 5mL
14. Add in enough media to the cell media to make a total of 10mL (.250mL + 9.75mL)
15. Make sure the cells are evenly distributed in the plate and put it back into the incubator

### **Cell Counting:**

1. Clean the hemocytometer with 70% ethonal and rinse with water.
2. Put the coverglass on the hemocytometer and pipette 50uL into the crevice, letting the area fill up by capillary action.
3. Count the cells under a microscope with a counter.
4. Use the four squares in the corners; count the boxes from left to right, top to bottom.
5. Divide the total by 4 to obtain the average number of cells per square.
6. The volume of each square is 100 nl (nanoliters) or 1/10,000 ml. Calculate total count per ml as follows. Make sure to take into account the original dilution of cells (if applicable) and the dilution used during trypan blue staining.
7. Calculate the total cell count by multiplying the above figure with the total volume of cell suspension from which the sample was drawn

Cell count/ml of suspension = Average count per square x dilution factor x 10,000

Total count = Cell count per ml x Total volume of suspension

## Protocol for Production of 100mL Cell Media

<b>Alpha MEM</b>	-	78mL
<b>Horse Serum</b>	10%	10mL
<b>FBS</b>	10%	10mL
<b>Glutamax</b>	1x(2mM)	1mL
<b>P/S</b>	1xStock(100mL)	1mL
<b>Total Cell Media</b>	-	100mL

## Appendix E: Protocol for Seeding Fibrin thread bundles with hMSCs using Rotator

### Materials:

- Sterile thread-bundle in Bioreactor
- Sterile PBS
- Sterile 1 mL syringe (3)
- Cell Suspension (100,000 cells/100  $\mu$ L)
- 50 mL conical tube
- Tube rotator (fully charged!)

### Procedure:

1. Use a sterile syringe to inject sterile PBS into bioreactor (by attaching syringe to the already inserted 27G needle).
2. Ensure all bubbles are eliminated from the bioreactor.
3. Attach slide clamp and remove/discard syringe. (Keep syringe needle in the bioreactor).
4. Allow 20 min for hydration
5. While bundle hydrates prepare cell suspension according to cell passaging protocol
6. Use new syringe to expel all sterile PBS from the bioreactor before seeding. For this, remove the slide clamp at the end opposite to the needle, draw air into a new sterile syringe and push the air into the bioreactor to expel all the PBS.
7. Use a new syringe (1 cc maximum) to inject cell suspension (100,000 cells / 100  $\mu$ L) into the bioreactor. For this, hold the bioreactor such that the open end of the bioreactor (one without slide clamp) remains elevated such that the cell suspension doesn't spill out while being injected. After 100  $\mu$ L of cell suspension is injected into the bioreactor, close the end opposite the needle by sliding the clamp onto the tubing.
8. After injecting the cell suspension and adding the slide clamp, remove the 27G needle from the bioreactor.
9. Place the bioreactor into a gas permeable 50 mL conical tube.
10. Place the bioreactor into the MACSmix tube rotator and rotate at 4 RPM (lowest setting) for 24 hours.

## Appendix F: Staining Protocol

### Phalloidin/Hoechst Staining

#### Reagents:

- Phosphate Buffered Saline
- 4% Paraformaldehyde (Only needed for tissues/cells that have not been fixed);
- 0.25% Triton-X
  - 0.25% V/V Triton-X in PBS
  - 10  $\mu$ L Triton-X in 3990  $\mu$ L PBS
- 1% BSA
  - 1% V (W)/V BSA in PBS
  - 40  $\mu$ L in 3960  $\mu$ L PBS
- Phalloidin (AF 488 Phalloidin A12379, Invitrogen)
  - 2.5% V/V Phalloidin in PBS
  - 50  $\mu$ L in 1950  $\mu$ L
- Hoechst
  - 0.0167% Hoechst dye in PBS
  - 0.5  $\mu$ L in 3000  $\mu$ L PBS

#### For unfixed sections/cells:

1. Rinse in PBS x2
2. Fix in 4% Paraformaldehyde for 10 minutes
3. Follow directions for fixed sections

#### For fixed sections/cells:

1. Rinse with PBS x2
2. Triton-X solution for 10 minutes
3. Rinse with PBS x2
4. Block with BSA solution for 30 minutes
5. Phalloidin solution for 30 minutes
6. Rinse with PBS x2
7. Hoechst solution for 3-5 minutes (typically 3)
8. Rinse with PBS x2
9. Cytoseal and coverslip
10. Store frozen at -20 degrees C.

#### Results:

- F-actin is stained green and nucleus is stained blue

## Appendix G: CyQUANT DNA Assay

### Materials

- DMEM, 10% FBS, 1% P/S (with supplements)
  - Lonza DMEM (Dulbecco's Modified Eagle's Medium)
  - FBS (Fetal Bovine Serum)
  - Pen Strep (Penicillin-Streptomycin Solution)
- Eppendorf Research Pipettes 1mL
- VWR™ tips for 1mL micropipette
- Eppendorf Research micropipettes 10µL
- RT-10F filtered tips for 10µL micropipette
- Drummond® Pipette Aid
- VWR™ Serological Pipettes 10ml
- ISOTEMP 210 Fisher Scientific (Water bath)
- Thermo Forma Class II A/B3 Biosafety Cabinet
- 70% Ethanol spray bottle
- ThermoFischer Scientific Hera Cell 150 ThermoElectron Corporation (Incubator 37°C)
- Pasteur Pipettes
- Molecular Probes/Invitrogen #C7026
- Lysis buffer only #C7027
- Costar® 3599 96 Well Culture Cluster (96 well plate)
- DPBS (Dulbecco's Phosphate buffered saline)
- Microcentrifuge tube rack
- Daigger Vortex Genie 2® A. Daigger & Co., INC.

### References

1. *Protocol for general aseptic technique*
2. *Protocol for cell harvesting (passaging)*
3. *Protocol for cell counting*
4. *Protocol for Plate reader*

### Dilutions

1. Using a micropipette, add 1 mL Lysis buffer to 19mL DPBS
2. Using a micropipette, add 50 µL GR (fluorescent) to 20 mL 1x Lysis buffer

### Method and Analysis

1. Aspirate off media, using a Pasteur pipette.
2. Using a micropipette, add 10 mL of DPBS.



3. Using a Pasteur pipette, aspirate off DPBS.
4. Using a micropipette, add 6 mL of trypsin. *See protocol for Cell Harvesting (Passaging)*. Read trypsinization section. Read centrifugation section.
5. *See Cell Counting Protocol*. Read entire document.
6. Using a micropipette, add as much media as necessary to create a cell suspension of 12,000 cells/100ul (using/saving 1mL of suspension –final cell #: 120,000/1ml).

**Note:** Can change cell concentrations if using/counting larger number of cells.

7. Centrifuge cell suspension down at 2,000 rpm for 5 minutes using the microcentrifuge.
8. Without disrupting the pellet, remove as much media as possible.
9. Add 500  $\mu$ L DPBS.
10. Centrifuge at 2,000 rpm for 5 min using the centrifuge.
11. Remove 400  $\mu$ L.
12. Freeze at  $-80^{\circ}\text{C}$  for at least 1 hour.

**Note:** The sample can be store up to 4 weeks in a  $-80^{\circ}\text{C}$  freezer.

13. In a 96 well plate, place 100  $\mu$ L of CyQUANT dye/lysis buffer into each well in Columns 1-4, Rows B-H.
14. Add additional 100  $\mu$ L of CyQUANT buffer to each well of H1-H4.
15. Remove microcentrifuge tube from freezer.

**Note:** Allow microcentrifuge tube and contents to reach room temperature. Do NOT place in water bath.

16. Vortex lightly using Vortex Genie 2.
17. When thawing is complete, add 900  $\mu$ L of CyQUANT buffer to Standard Curve microcentrifuge tube.

**Note:** The total volume in the Standard Curve should be 1000  $\mu$ L.

18. Lightly vortex using the Vortex Genie 2®.
19. Using a micropipette, take up the Standard Curve solution and dispense 200  $\mu$ L into each of the wells A1-A4.
20. Using a 1000  $\mu$ L micropipette, take up 100  $\mu$ L of CyQUANT buffer from the topmost well in a Column and dispense it into the well directly beneath it. Mix the solution in each well 6 times. Repeat this step through Row G.

**Note:** Row H wells have NO standard curve (this is blank).

21. Using a micropipette, add 100  $\mu$ L of CyQUANT buffer to each well from A1 to G4.

- a. **Note:** This will return the full amount to 200  $\mu\text{L}$ .

#### *Preparation for Sample Analysis*

1. After seeding cells on microthreads and incubating, remove materials from bioreactor.

**Note:** At this point, the cells on the microthreads should be ready to be counted.

**Note:** Make sure you have seeded a control thread with just media – this will give you a baseline fluorescent reading that your calculations depend on!

2. Using a micropipette, add 500  $\mu\text{L}$  of DPBS.
3. Centrifuge microcentrifuge tube at 2,000 rpm for 5 minutes.
4. Using a micropipette, remove 400  $\mu\text{L}$  of DPBS.
5. Place microcentrifuge tube in microcentrifuge tube rack.
6. Place rack in  $-80^{\circ}\text{C}$  freezer for at least 1 hour

**Note:** The sample can be store up to 4 weeks in a  $-80^{\circ}\text{C}$  freezer. The sample will include the thread. Once in freezer, the de-ionized water will lyse the cell membrane leaving the DNA behind. This means no trypsinization is required to remove cells from thread.

7. Remove rack from freezer.

**Note:** Allow microcentrifuge tube and contents to reach room temperature. Do NOT place in water bath.

8. Using a micropipette, add 400  $\mu\text{L}$  of CyQUANT lysis buffer.
9. Vortex lightly using the Vortex Genie 2®.
10. Using a micropipette, remove material from sample.
11. Place materials on a slide for staining.

**Note:** This will confirm cell removal.

12. Using a pipette, take up of solution with cells and dispense 100  $\mu\text{L}$  solutions into each of 4 wells.
13. Once all intended wells are complete,
14. For de-gassing, place in vacuum. This will remove bubbles.
15. Place 96 well plate on plate reader.
16. Run plate reader. (480nm excitation, 520nm absorption)

**Note:** Samples will saturate after 5 minutes of light exposure; work fast.

Should be 200  $\mu$ L in all wells of standard curve, if not add CyQUANT buffer until 200  $\mu$ L is reached.

17. Dispose of waste properly.

### *Calculations*

1. Place 96 well plate on plate reader. *See protocol for Plate reader.* Read operation related sections.
2. Copy obtained data into an empty Excel document. Calculate average, correlation coefficient, slope, and x-intercept of standard curve.

Note: To calculate the correlation coefficient type in desired cell (the cell locations should correspond to cells for calculation)

Ex: =CORREL(A3:A10,F3:F10)

To calculate the average type in desired cell (the cell locations should correspond to cells for calculation)

Ex: =AVERAGE(B3:BE3)

To calculate the intercept type in the desired cell (the cell locations should correspond to cells for calculation)

Ex: =INETERCEPT(F3:F10,A3,A10)

To calculate the slope type in the desired cell (the cell locations should correspond to cells for calculation)

Ex: =SLOPE(F3:F10,A3,A10)

3. Using average, multiple the average by 5 for 500 $\mu$ L.
4. Cell value for sample = (Average - y-intercept)/slope.

## Appendix H: Consistency testing protocol

### Materials

- Fibrin microthread bundles
- Scissors
- Tape
- Meter ruler
- Amscope 1N300TB microscope
- Clean slide

### Procedure

1. Cut the bundle to 10 cm in length
2. Tape one cm off at either end of the sample
3. Place the sample onto a clean glass slide and focus under microscope
4. Place ruler under microscope so that ruler marking and bundle are both visible
5. Take eight measurements along the length of the bundle
  - a. For each measurement count the number of half twists per 4 mm
6. Find the mean and standard deviation of twist for the sample

**Appendix I: Initial Prototype Images**

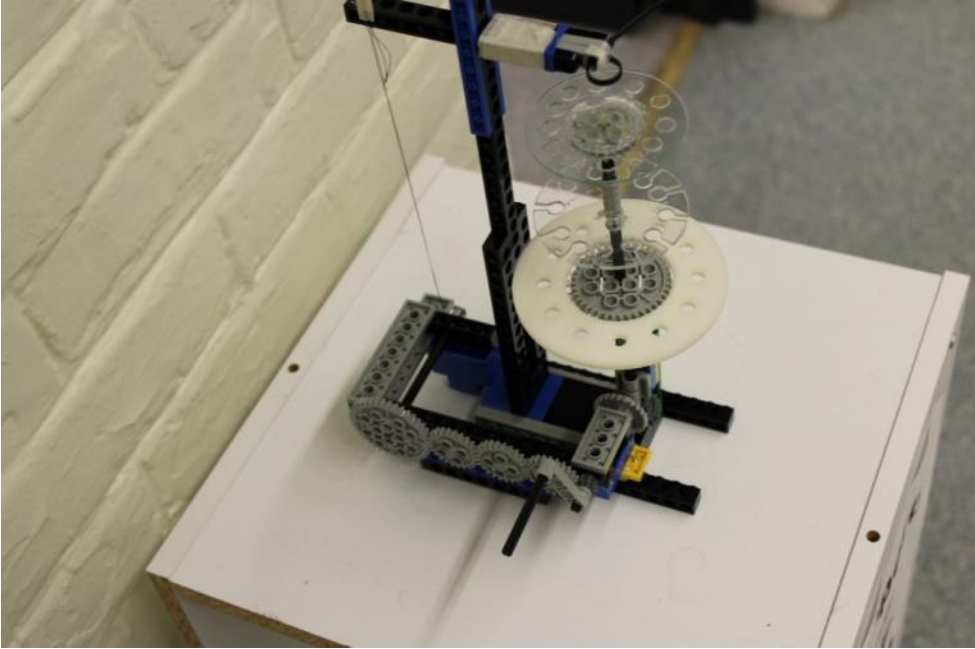

**Figure 1: Top view of initial prototype**



**Figure 2: Side view of initial prototype**



Figure 3: Front view of initial prototype

Appendix J: Second Prototype Images

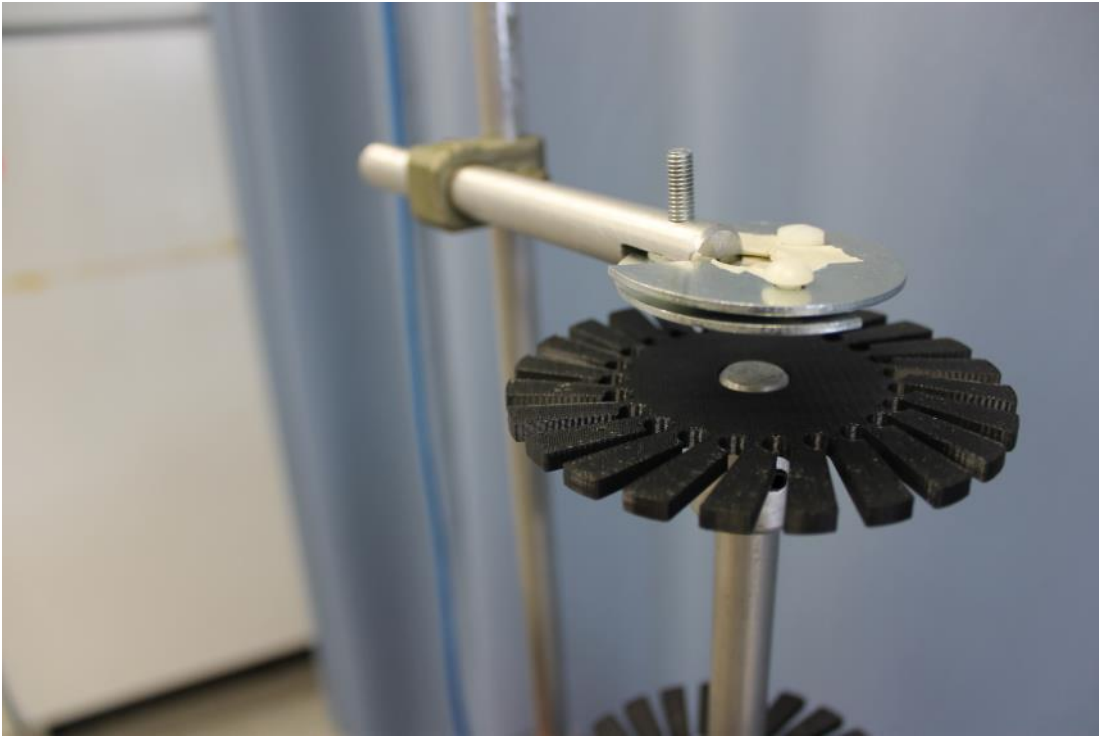

Figure 1: First disc with guiding hole

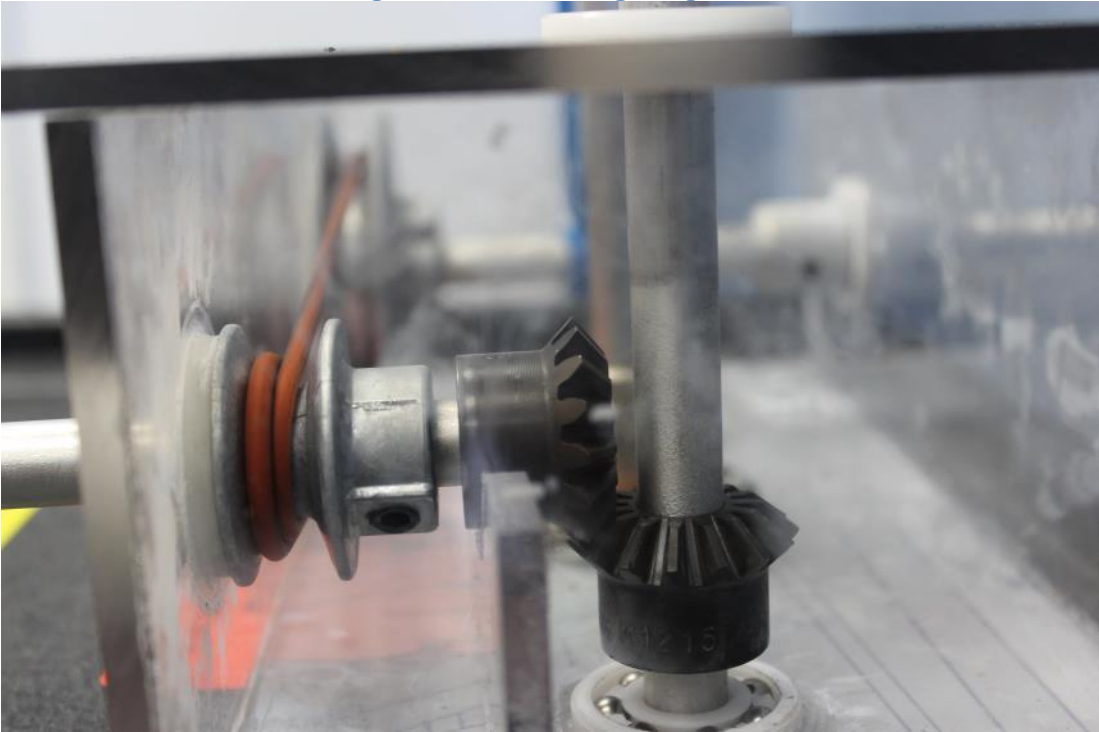

Figure 2: Gears at 90 degree in the base box

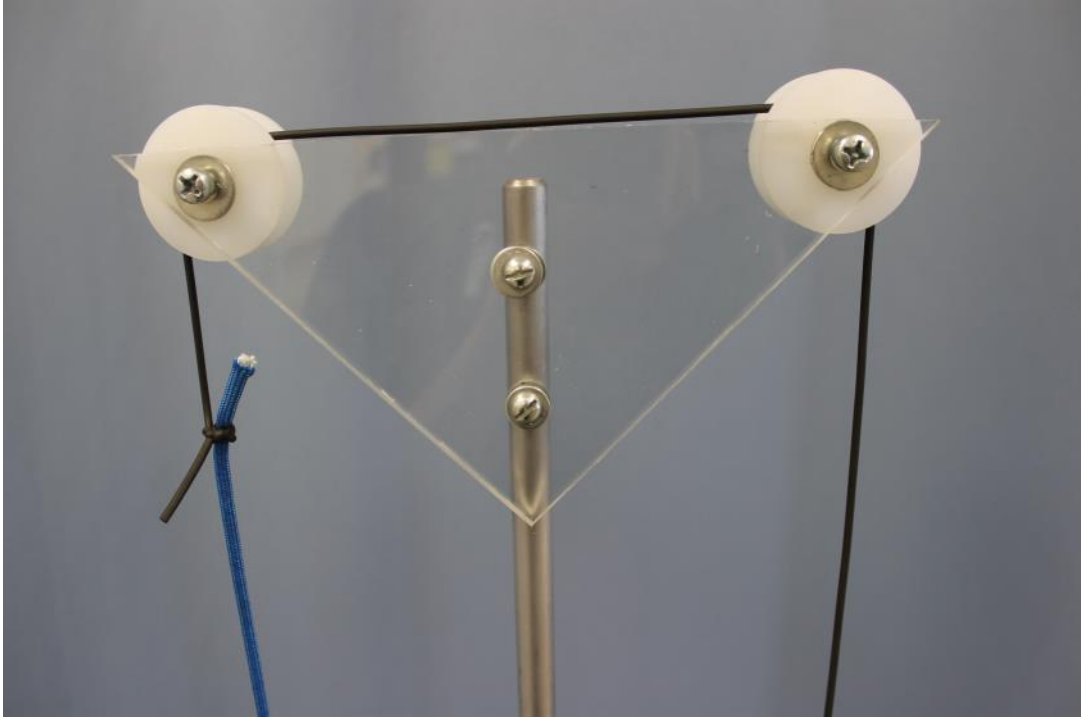

Figure 3: Pulleys at the top of the device



Figure 4: Top view of the base box



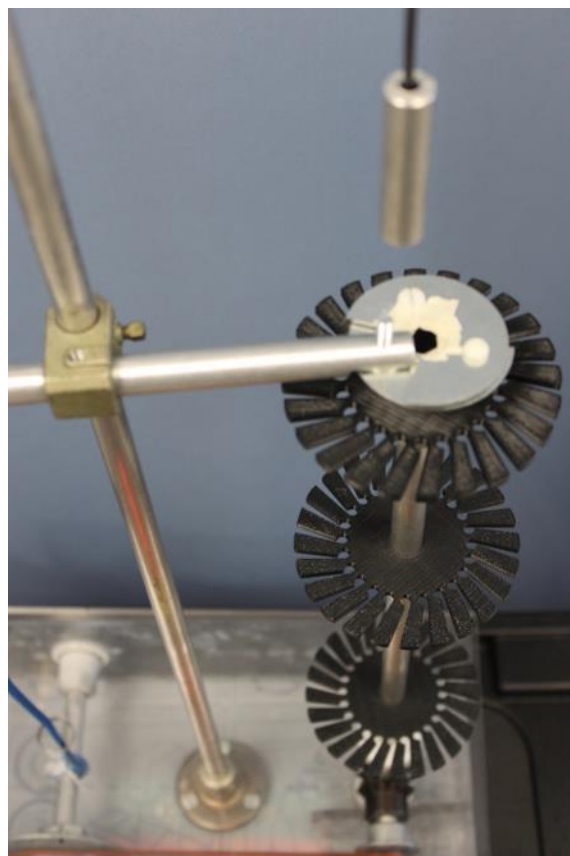

Figure 5: The three discs that hold microthreads with hanging unit



Figure 6: Front view of final prototype