

Patellofemoral Unloader Knee Brace

A Major Qualifying Project

Submitted to the Faculty of

WORCESTER POLYTECHNIC INSTITUTE

in partial fulfilment of the requirements for the

Degree of Bachelor of Science

Submitted By:

James Junker

Matthew Liberacki

Brianna Owen

Olivia Wisniewski

Advisors

Ambady, Sakthikumar

Department of Biomedical Engineering

Sabuncu, Ahmet C

Department of Mechanical Engineering

Table of Contents

Table of Contents

Table of Contents	2
Table of Figures	4
Table of Tables	6
Authorship	7
Acknowledgements	8
Abstract	9
1. Introduction	10
2. Literature Review	11
2.1. Anatomy and Biomechanics of the Knee	11
2.1.1. Bones	11
2.1.2. Tendons and Ligaments.....	13
2.1.3. Cartilage and Synovial Fluid.....	14
2.1.4. Contact Angle, Degree of Flexion, and Forces	15
2.1.5. Q-Angle	16
2.2. Complications of the Patella and Injuries	17
2.2.1. Subluxation and Dislocation	18
2.2.2. Patella Tendonitis and Patellofemoral Pain Syndrome	19
2.3 Patellofemoral Arthritis	20
2.3.1 Pathophysiology	20
2.3. Current Treatments	21
2.4. Benefits and Limitations	24
3. Project Strategy	26
3.1. Initial Client Statement	26
3.2. Revised Client Statement	26
3.3. Objectives & Constraints	27
3.4. Project Approach	27
4. Design Process	28
4.1. Needs Analysis	28
4.1.1. Stakeholder Groups	28
4.1.2. Stakeholder Interviews.....	29
4.1.3. Needs Statement	31
4.2. Design Requirements, Functions (Specifications)	32
4.3. Important Industry Standards	34

4.4.	Additional Considerations	35
4.4.1.	Economics	35
4.4.2.	Environmental Impact.....	35
4.4.3.	Societal Influence	35
4.4.4.	Political Ramifications	35
4.4.5.	Ethical Concerns	36
4.4.6.	Health and Safety Issues	36
4.4.7.	Manufacturability	36
4.4.8.	Sustainability.....	36
4.5.	Conceptual Designs.....	36
4.6.	Design Selection.....	39
4.7.	Modeling.....	42
4.7.1.	Conceptual Design Selection and Rationale	42
4.7.2.	CAD History	44
4.7.3.	Design Rationale.....	48
4.7.4.	Final Design Function	49
4.8.	Test Methods and Traceability.....	52
4.8.1.	Test Methods.....	52
4.8.2.	Traceability.....	54
5.	<i>Verification and Validation.....</i>	55
5.1.	Tensile Wire Test.....	55
5.2.	Dimension Test.....	57
5.3.	Flexion Test.....	58
5.4.	CT Test	58
5.5.	Kinematic Motion Tracking	61
5.6.	FujiFilm.....	67
5.7.	C-Clamp Test	69
5.8.	General Systems Testing.....	70
5.9.	Human Test.....	71
5.10.	Open Sim	72
5.11.	Fatigue.....	73
6.	<i>Discussion.....</i>	74
7.	<i>Conclusion and Future Steps</i>	75
8.	<i>References.....</i>	76
	<i>Appendices</i>	79

Table of Figures

Figure 1: Frontal image of the patella [6]	12
Figure 2: Femoral Chondral A condyle is a round extension at the end of some bones, often coming in pairs. A fossa is a shallow depression in the bones [6].....	12
Figure 3:A leg transitioning from full extension to full flexion [7].....	13
Figure 4: A) Patellar Tendon and Quadricep Tendon [9] B) Ligaments of the knee [10].....	13
Figure 5: Patellofemoral Joint [11]	14
Figure 6: Diagram depicting Q-angle [12].....	16
Figure 7: The path of PFA diagnosis	18
Figure 8: The difference between patellofemoral subluxation and dislocation [15]	18
Figure 9: Example stretches and exercises for patellofemoral pain [24].....	22
Figure 10: McConnell Taping [3]	23
Figure 11: Partial and Total Knee Replacement [22]	23
Figure 12: Three-point unloader knee brace [28]	24
Figure 13: Gantt chart for PFA unloader knee brace project.....	27
Figure 14: Example of conceptual design 1	37
Figure 15: Example of conceptual designs 2	38
Figure 16: Baseline design- DonJoy Tru-Pull Sleeve Advanced System [15]	38
Figure 17: Top 3 designs selected from Pugh comparison chart	43
Figure 18: Generation 1 Full Rigid Base Assembly Drawing	44
Figure 19: Generation 2 Full Rigid Base Assembly Drawing	46
Figure 20: Generation 3 Full Rigid Base Assembly Drawing	47
Figure 21: Generation 4 Full Rigid Base Assembly Drawing	48
Figure 22: Generation 4 Brace Prototype Wire Orientations. Left image shows the “across side” orientation, while the right image shows the “same side” orientation.....	50
Figure 23: Generation 4 Rubber Band Function.....	51
Figure 24: Order of test completion.....	55
Figure 25: Example of the wire break.....	56
Figure 26: Measurement of the brace dimensions	57
Figure 27: Measure of flexion.....	58
Figure 28: The cross-sectional measurement of the patella.....	60
Figure 29: The measurements taken between the patella and femur	60
Figure 30: Comparison of the CT scans	61
Figure 31: Angle Bisector Theorem where A is on the patella, B is on the tibia and C is on the femur and of which all are along the sagittal plane of the leg	62
Figure 32: Patellar Lift.....	63
Figure 33: Relationship between angle and angle bisector.....	63
Figure 34: Flexion Angle Standard.....	64
Figure 35: Bisector Length vs Flexion Angle.....	65
Figure 36:Average Patellar lift vs Average Positive and Negative Control. Going from left to right the x axis labels are as followed: Across Hard configuration 0, Across Hard configuration 1, Across Hard configuration 2, Across Soft configuration 0, Across Soft configuration 1, Across Soft configuration 2, Same Side Hard configuration 0, Same Side Hard configuration 1, Same Side Hard configuration 2	67
Figure 37:Fujifilm Set-up	68

Figure 38: Fujifilm Results	68
Figure 39: General System Test Setup.....	70
Figure 40: Force Per 90 Deg Ratchet Turn	71
Figure 41: Picture of Subject Leg after Test.....	72
Figure 42: Gen 1 Hinge Subassembly Drawing in mm	108
Figure 43: Gen 1 Ball Bearing in mm.....	109
Figure 44: Gen 1 Upper in mm.....	110
Figure 45: Gen 1 Lower in mm.....	111
Figure 46: Gen 1 Upper Connector in mm	112
Figure 47: Gen 1 Lower Connector in mm.....	113
Figure 48: Gen 1 Hinge Inner in mm.....	114
Figure 49: Gen 1 Hinge Outer in mm	115
Figure 50: Gen 2 Pin Hinge Subassembly Drawing in mm.....	116
Figure 51: Gen 2 Upper Drawing in mm	117
Figure 52: Gen 2 Upper Drawing in mm	118
Figure 53: Gen 2 Upper Connector Drawing in mm	119
Figure 54: Gen 2 Lower Connector Drawing in mm.....	120
Figure 55: Gen 2 Hinge Drawing in mm	121
Figure 56: Gen 2 Hinge Pin Drawing in mm.....	122
Figure 57: Gen 2 Hinge Connector Drawing in mm.....	123
Figure 58: Gen 2 Ratchet Anchor Drawing in mm.....	124
Figure 59: Gen 4 Upper Combined in mm	125
Figure 60: Gen 4 Lower Combined in mm.....	126
Figure 61: Gen 4 Hinge in mm	127
Figure 62: Generation 4 C-clamp	128
Figure 63: Generation 4 Anchor Hook	129
Figure 64: 90 degrees of rotation.....	133
Figure 65: 180 degrees of rotation.....	133
Figure 66: The brace and thigh region of the leg are fixed by clamps, and by a team member placing a force on the quadriceps region to hold the leg down	138
Figure 67: This shows the initial brace structure with points marked to indicate start and end locations on the brace.....	140
Figure 68: Test Fixture for Fatigue Testing.....	144
Figure 69: Wire 1 graph.....	153
Figure 70: Wire 2 graph.....	155
Figure 71: Wire 3 graph.....	157
Figure 72: Negative Control	160
Figure 73: Positive Control.....	160
Figure 74: Across Hard 90 Configuration	160
Figure 75: Across Hard 180 Configuration	161
Figure 76: Same Side Hard 0 Configuration.....	161
Figure 77: Same Side Hard 90 Configuration.....	161
Figure 78: Same Side 180 Configuration.....	162
Figure 79: Across Hybrid 0 Configuration	162
Figure 80: Across Hybrid 90 Configuration	162
Figure 81: Across Hybrid 180 Configuration.....	163

Figure 82: Across Hard Configuration Compared to Controls.....	164
Figure 83: Same Side Hard Configuration Compared to Controls.....	165
Figure 84: Across Hybrid Configuration Compared to Controls.....	166
Figure 85: All Data Compared.....	167

Table of Tables

Table 1: Force applied to the patellofemoral joint in various activities [2] [3]	15
Table 2: User needs identifier table	32
Table 3: List of design requirements	33
Table 4: Pairwise Comparison Chart	40
Table 5: Pugh Comparison Chart.....	41
Table 6: Design Requirements and Test Method Traceability Matrix	54
Table 7: Tensile Wire Test Results.....	56
Table 8: Brace Measurements.....	57
Table 9: CT Trials Conducted.....	59
Table 10: Linear Relationship Between Bisector Length and Flexion Angle	66
Table 11: Summary of C-clamp Selection.....	69
Table 12: Brace Configurations	131
Table 13: The locations of each sensor are denoted below in order to properly analyze the movements of the subject.....	135
Table 14: The Test Matrix used for the test including the experimental trials, 3 through 20, and the control trials, 1 and 2.....	135
Table 15: Pass Fail table TM-03.....	141
Table 16: Results Matrix for TM-09.....	151
Table 17: Example Ranking Matrix.....	151
Table 18: Wire 1 Data.....	152
Table 19: Wire 2 Data.....	154
Table 20: Wire 3 Data.....	156
Table 21: CT Scan Information	158
Table 22: Across Hard Data.....	163
Table 23: Same Side Hard Data.....	164
Table 24: Across Hybrid Data	165
Table 25: All Data Compared.....	166
Table 26: C-clamp Analysis 1.....	168
Table 27: C-clamp Analysis 2.....	168
Table 28: General Systems Data.....	172

Authorship

Section	Author	Editor
Introduction	O.W.	J.J. M.L. B.O.
Literature Review	J.J. M.L. B.O O.W.	J.J. M.L. B.O O.W.
Project Strategy	M.L. O.W.	J.J. M.L. B.O O.W.
Design Process	J.J. M.L. B.O O.W.	J.J. M.L. B.O O.W.
Verification and Validation	J.J. M.L. B.O O.W.	J.J. M.L. B.O O.W.
Discussion	O.W.	J.J. M.L. B.O
Conclusion and Future Steps	O.W.	J.J. M.L. B.O O.W.

Acknowledgements

We would like to thank our advisors, Professor Ambady and Professor Sabuncu, for all their help with the project. Additionally, we would like to thank the project sponsor, Dr. Robert Meislin. Finally, we would like to thank Lisa Wall, Karen Troy, Tiffiny Butler, Todd Keiller and Dave Smith for all their support through the project.

Abstract

The knee joint is one of the most complex joints in the human body and it is prone to various anterior knee pain conditions, such as patellofemoral arthritis (PFA). This condition consists of the loss of articular cartilage between the patella and the femur. Upon market research conducted during the NSF I-Corps program, the team determined that there was an unmet orthotic need for solving PFA. To rectify this, a patent pending knee brace was developed to lift the patella and reduce friction between the bones which would relieve the pain felt by the patient. Motion tracking data and computed tomography images were taken of the interaction of the knee brace and a goat leg, which is analogous to the human leg, to evaluate the patellar lift. The analysis of the data seems promising and shows the need for future work such as an early feasibility study. The team was also named a finalist for the national Schulze Entrepreneurship Challenge and won the WPI Provost MQP Award in Biomedical Engineering.

1. Introduction

The knee joint is one of the most complex in the human body. The joint is made up of the femur, tibia and patella, as well as tendons, ligaments, and cartilage which are responsible for mobility [1] The knee joint is important because it bears the weight from the rest of the body. The forces acting on the patella change with different activities. For example, the force acting on the patella is half the individual's body weight when walking. The force greatly increases to 12 times body weight when the individual completes a deep squat [2] [3]. When so much force acts on the patella various conditions can develop.

One group of symptoms common in the knee joint is anterior knee pain which is indicative of other conditions such as patellofemoral arthritis. In this condition, the cartilage between the femur and the patella degrades. Cartilage is a soft load bearing tissue that is found between joints and ensures that the bones do not come in contact with each other [4]. The degradation of the cartilage causes bone on bone interactions. This interaction causes immense pain for the individual.

There is currently a range of treatments for people suffering from anterior knee pain. Short term treatments include non-steroidal anti-inflammatory drugs, physical therapy, patellar alignment taping and weight loss. These treatments work to help relieve the pain that is caused by anterior knee pain, however only for short periods of time. Some current long-term solutions for treating anterior knee pain include cortisone steroid injections and total knee replacements. These are invasive treatments that cost the patient in money and time. Additionally, none of these treatments address the problem forever because cortisone is temporary, and a knee replacement only lasts about 15 years. It is evident that there is a need for a noninvasive long-term treatment.

This need could be met with a knee brace which lifted the patella away from the femur. Currently, there is no brace on the market that pulls the patella away from the femur. The brace would need to avoid skin abrasion and reduce the pressure within the joint. The team created two design objectives when completing the design. The first was that the brace should lift the patella away from the femur thereby reducing the pain. The second objective aimed to offer superior

medial and lateral control of the patella. For this project, the development and testing of this knee brace was conducted.

2. Literature Review

2.1. Anatomy and Biomechanics of the Knee

The knee is one of the most complex joints in the body. A reason for this complexity is the relationship between the many elements of the knee which include bone, tendons, and ligaments. The bones that are associated with the knee include the femur, tibia, fibula, and patella. Tendons are a type of connective tissue that connects bones to muscles. The largest tendon in the knee is the patellar tendon. Finally, the knee has ligaments, which connect bone to bone. The knee has four main ligaments that are important for its stability. Another important feature of the knee is cartilage, which acts as a cushion between bones and prevents both friction and pain for people [1]. These components of the knee work in tandem to permit gait motion: the ability of legs to carry weight forward with each step. Biomechanically, this is accomplished due to powerful tendons along our thighs.

2.1.1. Bones

In the context of this project, the two most important bones are the patella and the femur. The patella is also known as the kneecap and it is the second largest sesamoid bone in the body [5] A sesamoid bone is a small bone that is located within a joint capsule or tendon. The patella is located within the patellar tendon that runs from the tibia to the quadriceps tendon. The quadriceps tendon is located proximal to the patella, and anterior to the femur, and is also responsible for producing the forces needed for gait motion [5].

The patella includes four unique features that provide a shape capable of sliding along the patellar groove. These features include a medial, an odd, and a lateral facet as well as a vertical ridge. Figure 1 provides a front view of the patella [6].

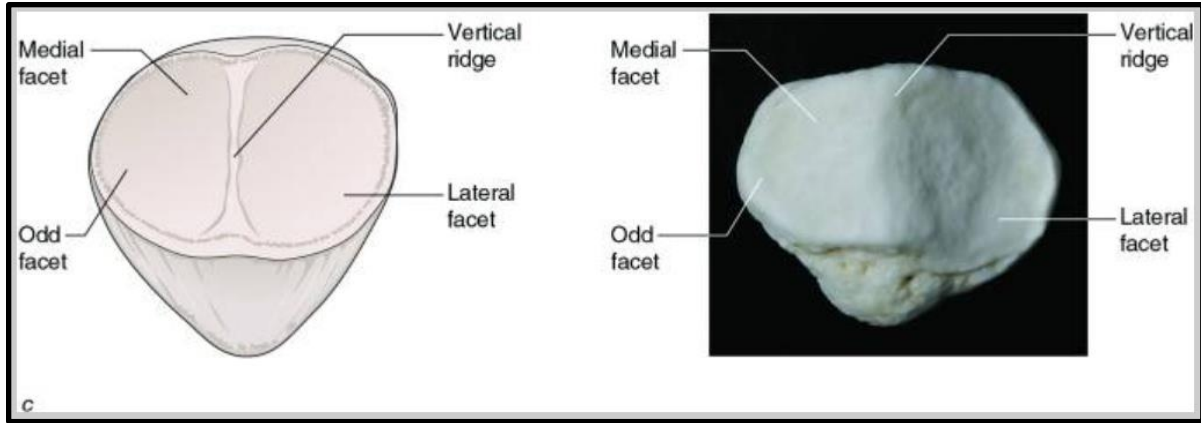

Figure 1: Frontal image of the patella [6]

The femur is a long bone that interacts with the patella through a layer of cartilage. The distal end of the femur looks like an inverted U, which is called the trochlear sulcus, or groove, as shown in Figure 2. It has articular cartilage in the medial and lateral facets. This helps to stabilize the interaction between the patella and the femur [6].

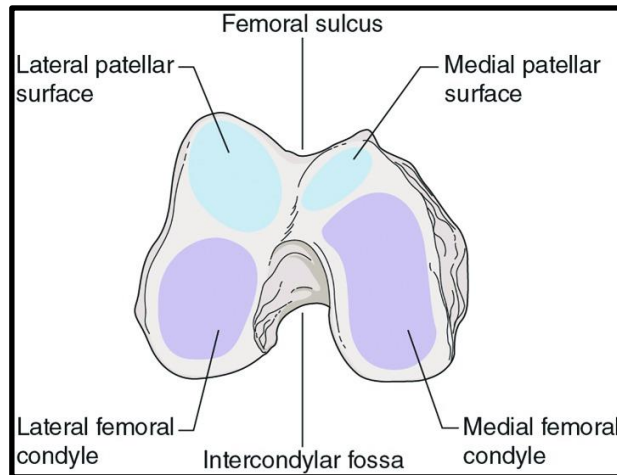

Figure 2: Femoral Chondral A condyle is a round extension at the end of some bones, often coming in pairs. A fossa is a shallow depression in the bones [6].

The purpose of the patella is to maximize the force vectors exerted through the quadriceps tendon. The gait motion is propelled by the compression and extension of skeletal muscles. The compression and extension of such muscles results in the motion of flexion and abduction of the leg distal to the knee. The average degree of flexion of the leg distal to the knee ranges from 0 degrees at full leg extension to 135 degrees at full flexion as shown as shown in Figure 3 [2].

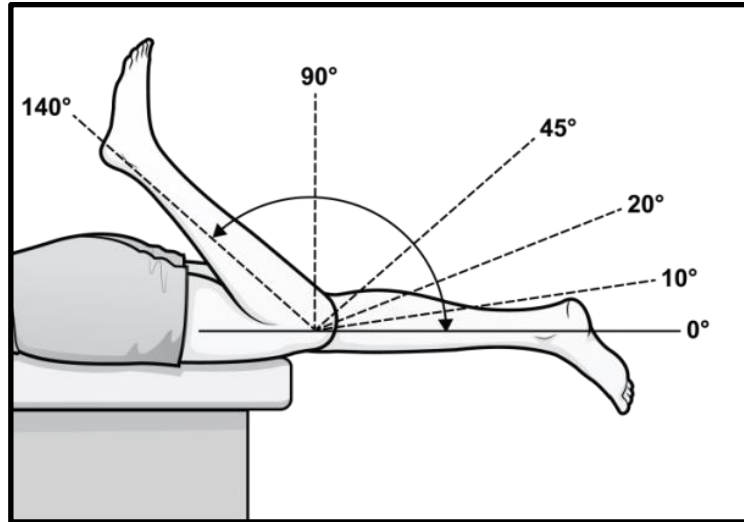

Figure 3: A leg transitioning from full extension to full flexion [7]

2.1.2. Tendons and Ligaments

Tendons connect muscles to bones. In the knee, the biggest tendon is the patellar tendon. The patellar tendon helps the joint become more stabilized by connecting the patella to the tibia. It connects from the quadriceps to the tibial tubercle and encapsulates the patella as shown in Figure 4A [5]. Tendons have a unique extracellular matrix. This matrix is made of tendon fibroblasts and collagen fibrils that create a fiber structure. Within this structure there are collagenous as well as non-collagenous proteins [8].

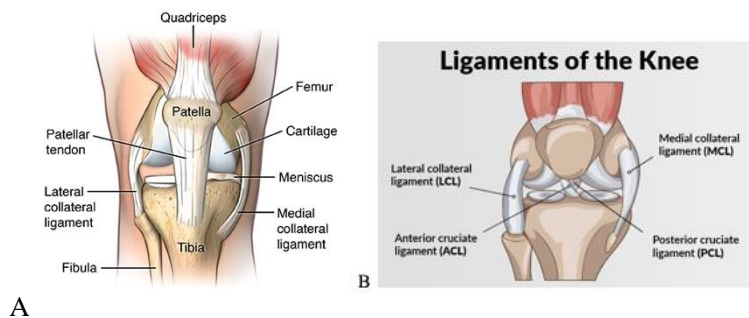

Figure 4: A) Patellar Tendon and Quadriceps Tendon [9] B) Ligaments of the knee [10]

In addition to tendons, ligaments provide the knee with more stability. A ligament connects bone to bone and the knee has four major ligaments. The first major ligament is the anterior cruciate ligament (ACL) as seen in Figure 4B. The ACL is responsible for 85% of the

stability in the knee. Another ligament is the posterior cruciate ligament (PCL) which inhibits the femur from moving posteriorly. The last two ligaments are the medial collateral ligament (MCL) and the lateral collateral ligament (LCL). The MCL works to limit movement in the medial direction and the LCL limits movement in the lateral direction. These four ligaments are essential to the stability of the knee [4].

2.1.3. Cartilage and Synovial Fluid

There are two types of cartilage found in the knee: the menisci and articular cartilage. The menisci are two cushions found between the femur and the tibia that act as shock absorption for the body. They act as a buffer between the bones and allow them to move without touching [4]. This is very important because when there is no buffer between the bones, they rub against each other causing pain for the individual. Articular cartilage serves a similar function to the menisci. Articular cartilage can be found between the patella, femur, and tibia, as seen in Figure 5. The main function of articular cartilage is that it allows bones to move freely past each other [4]. Osteoarthritis is a condition that develops from the degradation of cartilage, which can cause pain for the patient.

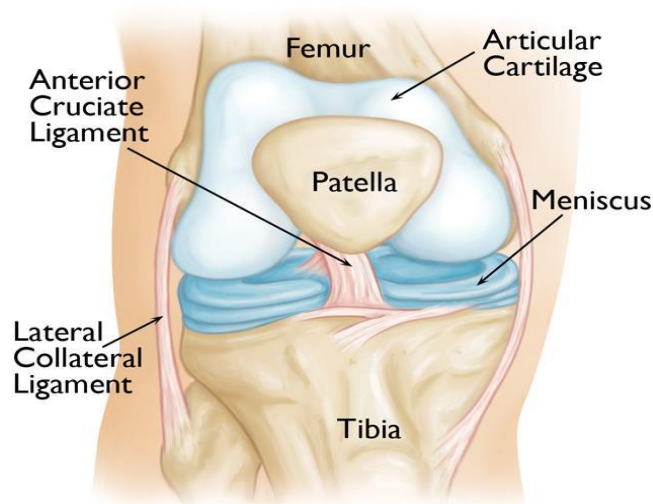

Figure 5: Patellofemoral Joint [11]

The purpose of the knee joint is to compensate for the weight of the body anterior to that joint's location. This weight is added to the load borne by that joint. The joint must be capable of absorbing kinetic energy to bear the load of the body when experiencing impulse on the joint. In this manner, the joint protects essential tissues, such as bone and skeletal muscle. Synovial fluid

and articular cartilage both serve to aid in supporting the forces from the movements. The supporting aspects of synovial fluid are due to its viscoelastic properties ($\sim 1 \text{ Pa s}^{-1}$). Articular cartilage serves as a firm and flexible barrier between bones in joint regions to prevent bone-on-bone abrasion [2].

2.1.4. Contact Angle, Degree of Flexion, and Forces

As the knee flexes, the patellofemoral contact area gradually increases. At 30 degrees of flexion, the average area of patella-to-femur contact is approximately 2.0 cm^2 . At 40 degrees of flexion, the average area increases to 4.0 cm^2 . At 90 degrees of flexion, the patella-to-femur contact increases to 6.0 cm^2 , which is the maximum contact the knee can experience. These metrics are relevant as patella-to-femur contact is directly proportional with pressure experienced [2]. An increase in the resultant force of the quadriceps accompanies the increase of knee contact area. However, the quadriceps muscles contract differently depending on the type of action.

Table 1: Force applied to the patellofemoral joint in various activities [2] [3]

Activity	Range for Angle of Flexion	% of Body Weight contributing to force
Walking	$\sim 20-60^0$	$\sim \frac{1}{2} \times \text{Body Weight}$
Biking	$\sim 0-40^0$	$\sim \frac{1}{2} \times \text{Body Weight}$
Stair-Ascending	$\sim 83-105^0$	$\sim 3.3 \times \text{Body Weight}$
Stair-Descending	$\sim 83-107^0$	$\sim 5 \times \text{Body Weight}$
Jogging	$\sim 90-105^0$	$\sim 7 \times \text{Body Weight}$
Squatting	$\sim 90-117^0$	$\sim 7 \times \text{Body Weight}$
Deep-Squatting	$\sim 117-135^0$	$\sim 12 \times \text{Body Weight}$

As seen in Table 1, an individual experience the greatest amount of force on the patellofemoral joint when undergoing deep squatting, or a squat ending with a flexion angle greater than 90 degrees. During this action, the quadriceps are functioning at maximum capacity. Ultimately, the greater the angle of knee flexion, the greater force is applied onto the patella.

2.1.5. Q-Angle

The Q-angle is an additional factor that influences pressure during flexion. The Q-angle is shown in Figure 6. The Q-angle is the angle between the vector parallel to the length of the femur and the straight vertical vector drawn from the patella upwards along the coronal plane. Patella-to-femur angles are positive when directed medial to lateral, and negative when directed lateral to medial.

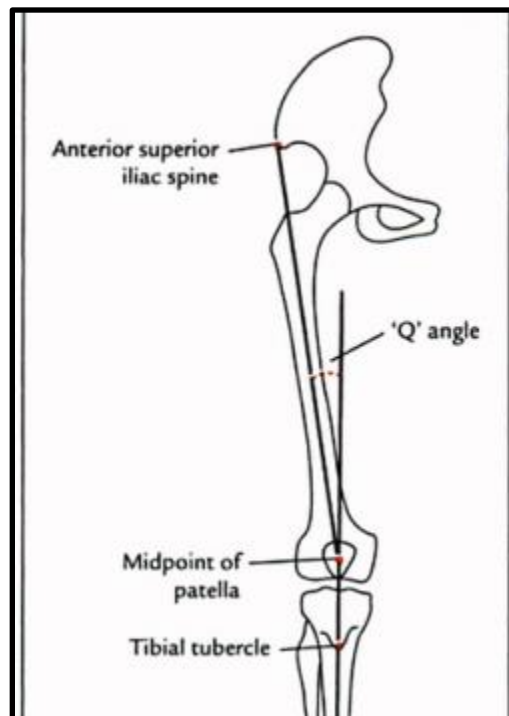

Figure 6: Diagram depicting Q-angle [12]

According to a study by Huberti HH, it was found that any increase or decrease in Q-angle resulted in an increase in peak pressures at the facets of the patella [13]. At 20 degrees of knee flexion with a Q-angle of 10 degrees counterclockwise, the peak pressure at the

patellofemoral joint would increase by approximately 45%. At 20 degrees of flexion with a Q-angle of 10 degrees medial to lateral, the peak pressure at the patellofemoral joint would increase by 50% [3]. Ultimately, Q-angle is indicative of misalignment. The greater the absolute value of Q-angle, the greater the misalignment.

2.2. Complications of the Patella and Injuries

Anterior knee pain is the general term which describes the pain that occurs at the front and center of the knee. The problems which cause anterior knee pain include conditions such as patellar tendonitis and patellar maltracking. All of these conditions result in the same anterior knee pain - hence the general term. However, it should be noted that anterior knee pain is a broad encompassing term, not a condition. There is always an underlying reason for the knee pain. The pain for all the conditions does manifest in very similar ways, which leads to the possibility of any pain management solution working for multiple conditions as well [Appendix I].

Due to the complexity of the knee joint and the large loads placed upon it, the likelihood of developing complications in the knee is high. These complications are varied, but one common complication is the development of osteoarthritis beneath the kneecap, known as patellofemoral arthritis (PFA). There are many solutions to these complications, ranging from physical therapy and bracing, to surgery. However, not all arthritic conditions in the knee are equal.

In general, there are three diagnoses for PFA: post-instability arthritis, post-traumatic arthritis, and overload osteoarthritis. This first diagnosis is the result of cartilage damage caused by repeated dislocations or subluxations in the joint, generally non-traumatic in nature. The second diagnosis refers to cartilage damage that results from a fall or other traumatic injury to the knee, that develops into arthritis. The last main diagnosis of patellofemoral arthritis is generally referred to as overload osteoarthritis, which is a condition resembling osteoarthritis in any other joint. This means the cartilage of the knee progressively thinned due to the usual wear associated with the compartment of the knee. This path is shown in Figure 7 and is diagnosed through minimally invasive methods [14].

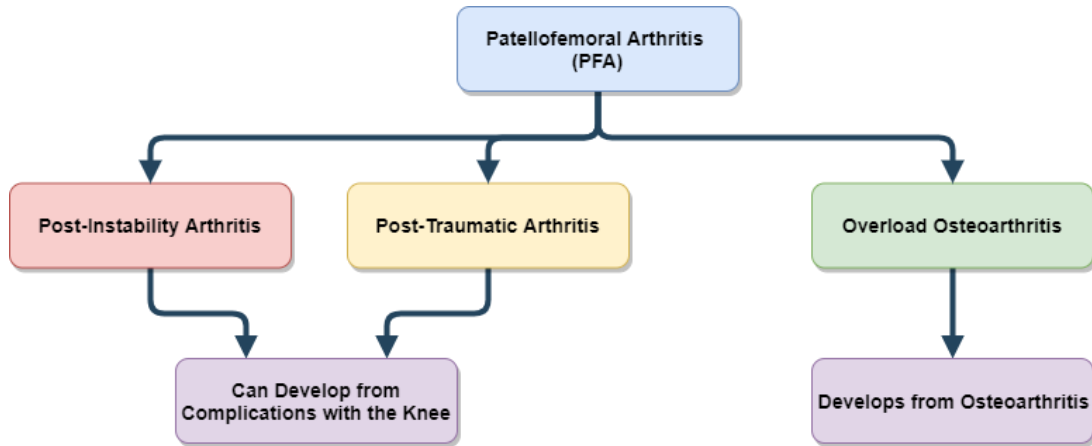

Figure 7: The path of PFA diagnosis

The following sections include injuries involving the first two diagnoses, and how they can lead to the development of patellofemoral arthritis.

2.2.1. Subluxation and Dislocation

The patella is prone to dislocation. One form of this is chronic patellar instability, also known as traumatic subluxation. This is when the kneecap will only partially dislocate out of the groove [14]. It is also possible for the kneecap to dislocate entirely, if presented with enough force. This is known as traumatic dislocation. The difference between subluxation and dislocation can be seen in Figure 8.

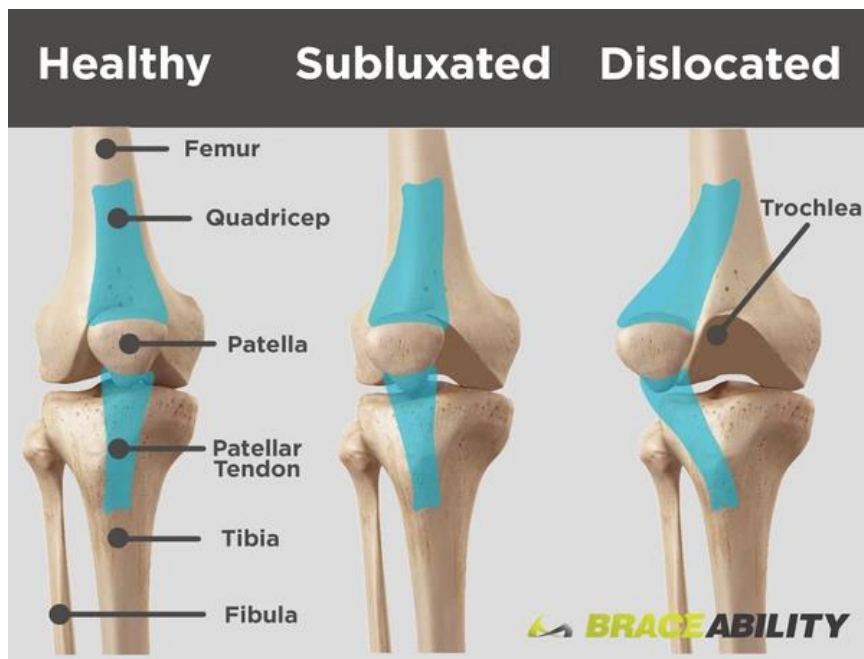

Figure 8: The difference between patellofemoral subluxation and dislocation [15]

Patellar instability is most common in children, especially females, but can be observed in adults as well. Other factors can affect susceptibility to patellar instability, such as cerebral palsy and down syndrome [16]. These conditions can often cause issues such as muscle weakness and balance problems which have an adverse effect on the kneecaps. In patellar subluxation, the patella gets shifted out of place within the femoral groove. Contrastingly, in patellar dislocation the patella gets pushed completely out of the groove. Patellar dislocation commonly occurs when someone's leg is planted on the ground but suddenly changes direction either from the person themselves or an outside force acting upon the patella. If the patella is dislocated in this method, it is known as traumatic patellar dislocation and it is common for this condition to develop into patellofemoral arthritis. The diagnosis in this instance would be post-traumatic arthritis.

There are also cases where the patella also might dislocate without an injury because there is a problem with the structure of the joint. There is a direct relationship between the presence of patellofemoral arthritis and a patient history of instability [16]. In general, when the trochlear groove is shallower or the ligaments connected to the patella are more flexible than normal, the patella is more likely to slide out of place. There are also cases of misalignment in knees which will cause pain in the patella. This form of patellofemoral pain is a patellar tracking issue, where a person's kneecap can push to one side of the trochlear groove upon bending of the knee which causes irritation and pain. These problems can arise from overall alignment issues between your leg and hip. They can also be due to an imbalance of strength between the medial and lateral leg muscles [14], [16]. For example, weak thigh muscles often contribute to this problem. This can also lead to patellofemoral arthritis and would be diagnosed as post-instability arthritis.

2.2.2. Patella Tendonitis and Patellofemoral Pain Syndrome

Patella tendinitis, often called "jumper's knee," or "runner's knee", is an inflammation of the patellar tendon and is the most common tendinitis of the knee. Patellofemoral pain syndrome is a general term that describes the pain in the front of the knee which often encompasses patellar tendinitis. Through personal communication with Mr. Mike DeSavage, the head athletic trainer [Appendix I], patellofemoral pain syndrome is most commonly observed in athletes who participate in basketball, volleyball, distance running, long jumping, mountain climbing, figure

skating, tennis, or even high impact aerobics. It typically affects adolescents and young adults whereas knee pain experienced by older populations is more commonly caused by arthritis. Patellofemoral pain syndrome is not patellofemoral arthritis, but these conditions can be mistakenly confused for one another.

2.3 Patellofemoral Arthritis

PFA refers to the pain and inflammation of the knee due to the degenerative changes underneath the patella. This form of arthritis can manifest in a range of ways, from no symptoms, to anterior knee pain, to severe difficulties with stair climbing. There is a condition called chondromalacia, also known as runners' knee, which describes the early degradation of articular cartilage that may eventually lead to PFA [17].

The patient population that is affected by PFA usually relates to those who have patellofemoral complications such as subluxation or malalignment, as well as the patient population affected by arthritis of other joints. Risk factors such as increasing age, obesity, or overuse, increase the odds for the development of arthritis in the knees. Prior dislocation of the patella is also a significant risk factor for patellofemoral arthritis. Medscape found in one cohort study of 609 patients, that almost fifty percent of patients, “had symptoms and radiographic changes consistent with arthritis at 25 years after lateral patellar dislocation” [18]. Most research into PFA now focuses on the anatomical and biomechanical causes of damage to the patellofemoral joint. These usually come in the form of shear forces, compressive forces, abnormal patellar tracking, and patella subluxation or dislocation. This directly correlates to the development of PFA in younger patients as a direct result of malalignment or a traumatic injury [18].

2.3.1 Pathophysiology

The articular cartilage of the patella is different than that of other joints. It is not necessarily congruent with the contours of the underlying subchondral bone. For example, in 60% of patellae, the thickest area of articular cartilage is located lateral to the thickest area in the underlying bone. This is not the only oddity surrounding the patellar joint. There have also been biomechanical studies which indicated that the patellar cartilage is more compressible than that

of other joints [18]. In general, by taking a look at the anatomy and composition of the knee, it is possible to tell many things about it including the intended mechanics of the knee. This remains true for the pathology of PFA as well. There are some indications of PFA that can be found in the anatomy of the knee.

Q-angle is thought to play a large role in the development of knee injuries and arthritis. It is hypothesized that, the larger the Q-angle, the greater the lateral tracking of the patella mechanism [18]. Normal Q-angles are less than 20 degrees and in general, women typically have larger Q-angles than men because of their wider hips. However, while the connection between Q-angles and the development of osteoarthritis is hypothesized, there is no definitive link between them and knee pathology. There have been several studies which demonstrated a trend among the increase in Q-angle with the predisposition to high rates of patellar maltracking [19].

At normal Q-angles, pressure should be evenly distributed across the patella. When there are increases in this angle, however, there can be a shift of pressure to the lateral facet or a change in the distribution of force. This is demonstrated in cadaveric studies whose findings show that with increasing Q-angle, the patella is shifted laterally and rotates medially as the knee is flexed. This is predicted to increase the lateral contact at the patellofemoral joint and to increase the incidence of patella subluxation and dislocation [18]. This outcome means that, due to these studies and others like them, many believe that an increase in Q-angle will have a direct impact on increased complications with the knee, either directly or indirectly leading to patellofemoral arthritis.

2.3. Current Treatments

Due to the complexity of the patellofemoral joint and the varying degree of severity associated with PFA, the treatments can range from short term pain management, to non-invasive rehabilitation treatments, to complete knee joint replacements.

Short term pain management is usually obtained by using anti-inflammatory drugs such as nonsteroidal anti-inflammatory drugs (NSAIDs) and cortisone steroid injections. These treatment options are only for pain management and do not actually improve the condition in the long term [20]. NSAIDs decrease pain by blocking the enzyme cyclooxygenase which is produced when a joint is injured or inflamed. Some common NSAIDs include aspirin, ibuprofen,

naproxen, and nabumetone. Cortisone injections are steroids that reduce inflammation, which results in a reduction of pain in the joint. These injections can last months within the body, requiring only 3-4 shots per year. Cortisone injections are generally more effective and powerful than traditional NSAIDs [21].

Other treatment options focus on non-invasive rehabilitation. The most straight-forward treatment is weight loss. By reducing the forces acting on the joint, the pain in the joint is also decreased [22]. Another popular treatment is physical therapy because it is non-invasive and can be used in conjunction with other treatments. Physical therapy focuses on decreasing pain by strengthening and stretching the muscles and ligaments around the patella. This decreases the stress on the joint and improves the tracking in the trochlear groove. Physical therapy is popular because it is highly customizable to the individual, their specific symptoms, and their physiology. Some exercises include straight leg lifts, external hip rotations, and wall slides as well as stretches focusing on the hamstring, calf, iliotibial band, and glute, as seen in Figure 9 [23].

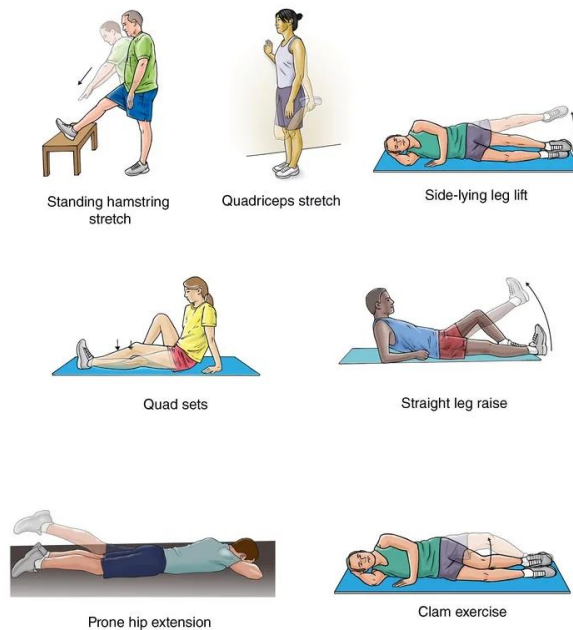

Figure 9: Example stretches and exercises for patellofemoral pain [24]

In addition to physical therapy, patients can use taping to treat PFA. This treatment is often preferred for short term pain management in athletes. Taping decreases pain by aligning and supporting the patella. The most common taping technique is the McConnell Taping shown

in Figure 10. This technique applies a lateral force to move the patella in the medial direction. This leads to a reduction in pain because it aids the alignment of the patella in the trochlear groove [25].

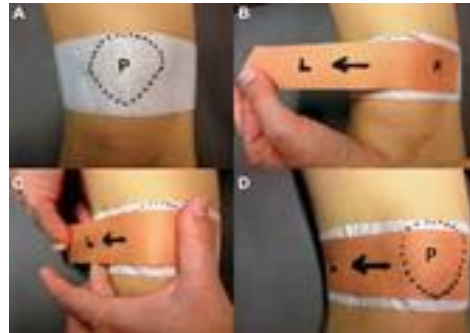

Figure 10: McConnell Taping [3]

If non-invasive treatments fail to treat PFA, more invasive treatments can be pursued. One such treatment is viscosupplementation. This procedure injects hyaluronic acid into the joint once every 6 months to act as a lubricant to reduce any potential grinding within the joint. However, the efficacy of this treatment remains controversial, as some patients do not experience any reduction in pain [26]. The most invasive option involves surgically treating PFA by a total knee replacement, as shown in Figure 11. This is often a last resort for patients suffering PFA. This surgery either partially or completely replaces the patella and surrounding damaged cartilage with a prosthetic implant.

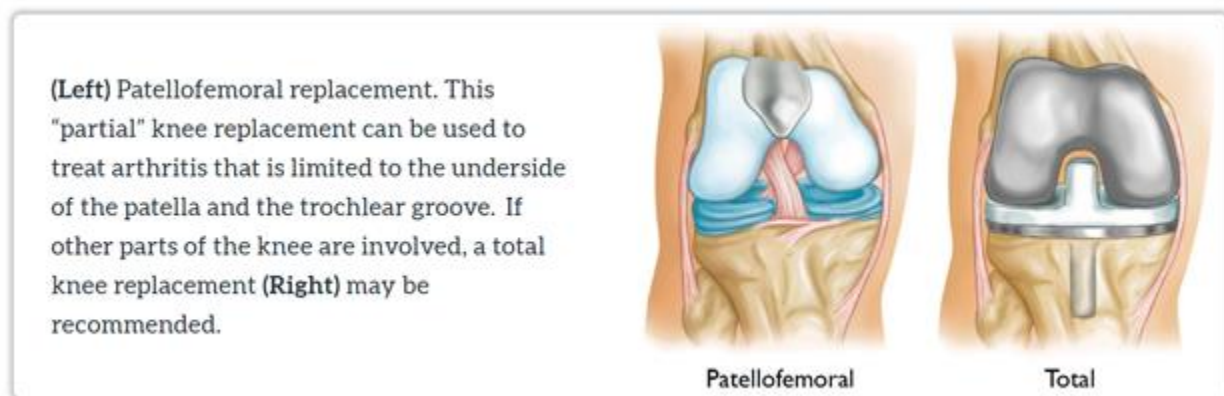

Figure 11: Partial and Total Knee Replacement [22]

By removing and replacing the affected areas of the joint, the surgery aims to reduce inflammation and pain in the joint. This surgery, however, is highly invasive and requires a long recovery period. It also presents multiple risks, including implant loosening, deep venous thrombosis, infection, and osteolysis [27].

Braces can be used to treat PFA. This treatment is often used in conjunction with physical therapy. Unlike other pain management treatments like NSAIDs, when bracing is coupled with physical therapy, it can be used for long term rehabilitation and decreased drug use. An advantage of using braces are the wide variety of designs on the market that patients can choose from to address their specific needs. Furthermore, they are inexpensive compared to surgical options. One of the most common brace types to treat pain in the patellofemoral joint is the unloader knee brace as shown in Figure 12.

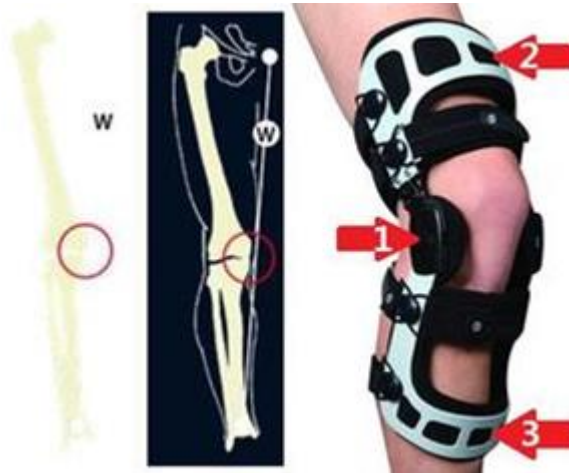

Figure 12: Three-point unloader knee brace [28]

These braces focus on reducing the abduction moment of the knee by utilizing a three-point loading design to decrease pressure on one side of the joint [29]. However, this brace design does not adequately address PFA because the brace does not reduce the contact area of the patella on the femur. Additionally, from professional feedback, the DonJoy Tru-Pull was a favorite for treating patients with Patellofemoral pain or arthritis, but there are currently no braces on the market that directly attempt to mechanically unload the patella. All braces on the market currently can be categorized as either a compressive sleeve, patella alignment braces such as J-braces like the Tru-Pull, an unloader brace as seen in Figure 12 above, or an immobilizing brace that is frequently used after knee and leg surgeries.

2.4. Benefits and Limitations

When treating PFA, non-invasive treatments like NSAIDs, cortisone shots, physical therapy, taping, and bracing are always first options as they present less risk to the patient.

NSAIDs, cortisone shots, taping, and bracing can also be cheaper than other options available like surgery. However, physical therapy, taping, bracing, and surgery offer long term rehabilitation and recovery from PFA.

Treatment options like surgery that can completely remove damaged tissues in the joint involve more risk and have a longer recovery time than other treatment options. Additionally, research shows that patients who underwent surgery for an earlier knee dislocation or subluxation had the same rate of recurrence of subluxation as patients who did not have surgery and were also more likely to develop arthritis in their knee [30] [31]. Other treatments like NSAIDs and cortisone shots, while cost effective, do not directly treat PFA and will not cause an improvement in arthritis over a long period of time. Currently, bracing and taping focus on patellar alignment and stabilization in the trochlear groove. These treatments do not necessarily alleviate any pain associated with grinding between the patella and the cartilage underneath in the trochlear groove. There are currently no braces, or treatment options, that are designed to lift the patellar up off the cartilage to relieve the grinding stresses.

3. Project Strategy

3.1. Initial Client Statement

“Patellofemoral arthritis occurs when the articular cartilage of the undersurface of the patella and the adjoining trochlea wear down. Biomechanically, maximum forces at the PF joint at 55-60 degrees of flexion. Anterior knee pain is multifactorial, caused by PF arthritis, hypermobility, patellar misalignment, lateral compression, or quadriceps/patellar tendinitis. Current unloader knee braces available on the market address only medial or lateral compartment arthritis (bone on bone). There is no unloader knee brace for the PF compartment in part due to the challenge of how to effectively unload this compartment. The primary focus of this project is to create a 3-point pivoting system for the PF joint. The device should:

1. Circumferentially pull the patella away from the trochlea during the active flexion and extension of the knee; a gripping type device for the patella hinged to the brace.
2. Avoid skin injury.
3. Reduce pressure at the PF joint.”

-Initial client statement provided by the project’s sponsor, Dr. Robert Meislin.

3.2. Revised Client Statement

“Patellofemoral arthritis and anterior knee pain cause pain for patients in the knee joint. There are no current unloader knee devices on the market, that successfully address the needs of these individuals. There is a current market need for a non-invasive solution, that offers instant pain relief, and requires no professional help beyond diagnosis. The primary focus of this project is to create an off the shelf unloader knee brace for the PF joint. The device should:

1. Circumferentially pull the patella away from the trochlea during the active flexion and extension of the knee.
2. Avoid skin injury.
3. Reduce pressure at the PF joint.
4. Provide medial and lateral control of the patella.”

In addition to the initial client statement provided by Dr. Robert Meislin, the team was able to design the brace to enhance the physical manipulation of the patella compared to current braces on the market. In the event that the brace was not capable of lifting the patella

superficially from the femur, the brace would still be able to minimize knee pain by allowing for adjustable lateral and medial manipulation of the patella. Additionally, the knee brace’s user demographic expanded to include patients with anterior knee pain.

3.3. Objectives & Constraints

The goal of this project was to create a knee brace that would minimize the pain felt by the patients with patellofemoral arthritis and anterior knee pain. To accomplish this goal, the team’s primary objective was to design a knee brace that reduces the contact between the patella and femur during flexion and extension, thereby reducing the pain.

The team’s secondary objective is to design a knee brace that would allow for the user to control lateral and medial displacement of the patella, providing enhanced customizability for the user. Such a brace would compete with braces currently used for patellofemoral pain that isolate the patella, as well as compete with professional care techniques, such as KT taping.

3.4. Project Approach

Shown below in Figure 13 is the team’s Gantt Chart, representing the tasks the team set forth along with start and end dates for each task. Tasks labelled as “TM-” are considered “test methods”, or detailed experiments that follow a particular procedure, which are expanded on in section 6.8.

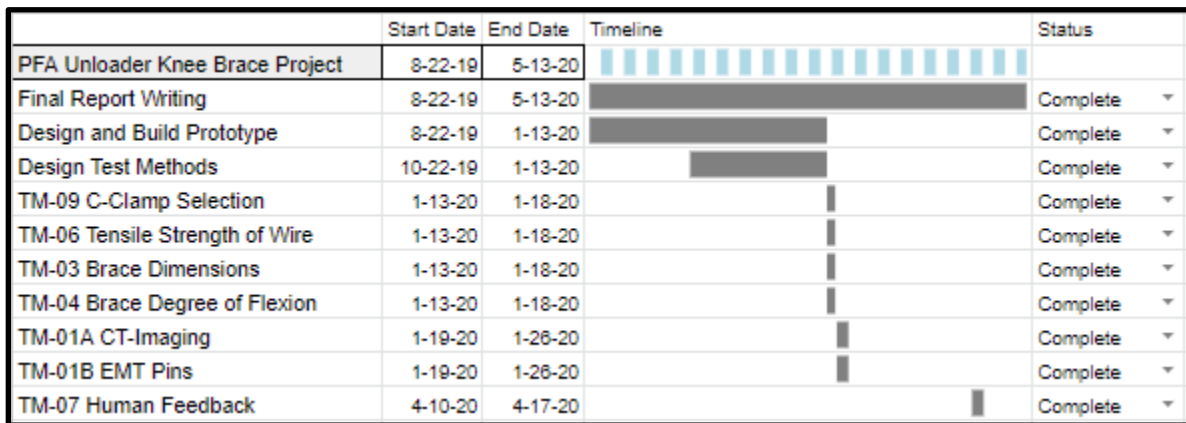

Figure 13: Gantt chart for PFA unloader knee brace project

4. Design Process

4.1. Needs Analysis

4.1.1. Stakeholder Groups

The team participated in the National Science Foundation I-Corps program which focuses on customer discovery and is led by WPI's Director of Intellectual Property and Innovation, Todd Keiller. Part of the program encouraged interviewing people to understand the unmet market need. In order to better understand the current unmet market need for treating anterior knee pain, specifically patellofemoral arthritis, the team sought insight from various stakeholder groups. The team decided to seek interviews with the following stakeholder groups: Engineering experts, end users, medical doctors and healthcare professionals, athletic trainers, physical therapists, insurance underwriters, and bracing specialists.

Engineering experts were important contacts to have, as they can provide input on design concept feasibility and options for verification testing. Potential end users of our brace, or patients with anterior knee pain, were essential to speak with as their input would unveil user needs and guide design requirements. Medical doctors and healthcare professions include individuals who work with potential end users that provide clinical insight into the market need. Athletic trainers, specifically those who work in academic institutions, work with a younger population of potential end users who possess the prerequisite conditions for patellofemoral arthritis. These athletic trainers could provide us with insight on the types of knee injuries they observe, what products exist on the market for treating these injuries, how they are used, and challenges that exist for brace end users. Physical therapists are able to provide similar information as athletic trainers, but physical therapists work with a wider variety of people of various ages and backgrounds. Interviewing physical therapists expanded our knowledge of the need that exists for potential end users. Insurance underwriters work with engineers and clinicians to help verify the need of healthcare products, orthopedics included, and approve these devices for subsidization using the Healthcare Common Procedure Coding System (HCPCS). Lastly, bracing specialists include those who obtain the necessary health information, such as leg dimensions, to create a custom brace that best fits the end user's need. In this way, bracing specialists act as middlemen between end users and bracing companies.

4.1.2. Stakeholder Interviews

The two engineering experts we were able to interview were both WPI Biomedical Engineering faculty members. Dr. Tiffany Butler, the director of Multicultural Affairs at WPI and an Assistant Teaching Professor in the Biomedical Engineering Department (BME), and Dr. Karen Troy, a BME Professor at WPI specializing in biomechanical research. Dr. Butler has received her Masters and Doctoral degrees in Kinesiology (Athletic Training and Integrative Exercise Physiology). Much of the discussion with professor Butler revolved around the initial design ideas for the brace as well as potential methods for measuring its success. In particular, the team's discussion with Dr. Butler provided insight into the early design iteration of the brace and was an inspiration for the measurement of patellar movement through kinematic tracking sensors. She also had several useful contacts, including Dr. Karen Troy, a BME professor at WPI, for further guidance. The full interview with Dr. Butler can be found in Appendix I.

Dr. Troy informed us of testing methods for us to consider for verification testing of the knee brace. Some of her verification testing suggestions included: using the computed tomography (CT) scanner at WPI's Gateway Park, using the pressure sensitive film called Fujifilm, using kinematic tracking sensors for motion tracking, and using OpenSIM software for knee joint finite element analysis. Additionally, Dr. Troy suggested that we extend our project to include multiple objectives, as our primary objective (lifting the patella), may prove to be too difficult an endeavor because of the forces required to lift the patella and the nature of the joint. The full interview with Dr. Butler can be found in Appendix I.

In accordance with HIPAA privacy laws, the team chose not to seek out those with patellofemoral arthritis through connections with healthcare professionals. Instead, the team chose to interview individuals within the WPI community who expressed concern about knee pain. Due in part to the COVID-19 pandemic bringing our interview rate to a halt, we were not able to interview anyone who was specifically diagnosed with patellofemoral knee pain. Part of the essential information gained from these interviews were that tendonitis in the muscles around the knee joint can lead to anterior knee pain of some kind, and that there are mixed reviews on the effectiveness of the brace. Some think that they are irritating and do not work. Some think they work fine. Some think they work only as a placebo effect. The full potential end user interviews with WPI Community Members 1, 2 and 3 can be found in Appendix I.

Of the healthcare professionals spoken with, the first was our project's sponsor, Dr. Robert Meislin. In the initial phases of the project, the team video called with Dr. Meislin. The goal of this interview was to answer questions the team had when conducting their literature review. He helped the team find information about the force vectors acting on the patella during different movements. He recommended we determine the patellofemoral joint forces by reading through peer reviewed journal articles. He provided us with our initial client statement and described the potential benefit of creating an unloader knee brace. The population that he sees with this condition ranges from young athletes to the elderly population. The team also learned that common treatments that Dr. Meislin had previously treated patients using KT tape, cortisone shots, and, in extreme cases, surgical procedures. He said that a brace would be an ideal initial step for patients to use once it is developed. The full interview with Dr. Meislin can be found in Appendix I.

Other healthcare professionals spoken with included a University of Massachusetts (Umass) Memorial Medical Center orthopedic surgeon, a Umass Memorial Medical Center sports medicine doctor, and a retired registered nurse. Part of the information gathered from these individuals were that females age 30-40 and anyone age 50+ are at a higher risk of developing osteoarthritis. Several treatments exist, but there is a need for a long lasting, effective treatment of osteoarthritis. Also, osteoarthritis dramatically affects the knee's mechanical ability. The full interviews with the Umass Memorial Medical Center orthopedic surgeon, a Umass Memorial Medical Center sports medicine doctor, and a retired registered nurse can be found in Appendix I.

One of the athletic trainers the team interviewed was Mr. Mike DeSavage, the head athletic trainer at WPI. His master's thesis focused on creating a shoulder brace, and in his time as an athletic trainer he has worked with different taping techniques and braces for athletes. Part of his role at WPI involves working with athletes to manage their pain. He also noted that athletes with patellar pain tend to have swelling around the knee, which is a good indicator of injury. Additionally, DeSavage recommended that the team analyze DonJoy braces as references. The full interview with Mike DeSavage can be found in Appendix I.

Other athletic trainers and physical therapists interviewed include two members of WPI's athletic trainer staff, physical therapists from Worcester PT in Massachusetts, and physical therapists from Greendale PT in Worcester, Massachusetts. Among the information obtained

from these interviews, the team was informed that athletic trainers really do not encounter any patients with arthritis, just those with the prerequisites, such as patellar malalignment. Athletic trainers also explained that bracing is rarely used as isolated treatment and is usually paired with other treatments such as physical therapy. Physical therapists hold the perspective that younger people are at a greater risk for poor lateral patellar tracking, while older people are at a greater risk of osteoarthritis. Female patients are usually at greater risk of developing such knee pain. Patients attending physical therapy normally attend 2-3 sessions of physical therapy per week. The full interviews with WPI's athletic trainer staff, physical therapists from Worcester PT, and physical therapists from Greendale PT can be found in Appendix I.

The team was able to interview underwriters from Fallon Health, Ninestone, and the Milford Regional Physician Group. From these interviews, the team learned about HCPCS codes and how they are used for billing orthotics devices. The brace code that the team's brace will likely fall under is identified as M17.9, with several subset codes available. The full interviews with Fallon Health, Ninestone, and the Milford Regional Physician Group can be found in Appendix I.

The team was able to interview a bracing specialist who works for Surgi-care. From this individual, the team gained a better understanding of the price ranging of braces. Lower end knee stabilizing braces range from \$100 to \$200, while customized braces range from \$600 to \$1000. The full interview can be found in Appendix I.

4.1.3. Needs Statement

The team was able to identify different needs for this project based on the interviews with our sponsor, Dr. Meislin and different stakeholder meetings. The team organized the user needs, in no particular order, in Table 2.

Table 2: User needs identifier table

ID #	User Needs
U1	The Device should be able to unload the patella from the knee joint
U2	The Device should reduce or eliminate Patellofemoral pain
U3	The Device should be easy to wear in all normal ranges of motion
U4	The Device should be durable and stand up to a year of constant use at minimum
U5	The Device should be lightweight and breathable
U6	The Device should be easy to use
U7	The Device should be affordable
U8	The Device should be adjustable for the individual

The first user need is that the device needs to remove the patella from the femur. This aligns with the second user need because preventing friction between the patella and femur will theoretically decrease patient pain. The third need is to ensure comfort for the user and maintain their normal gait. This is essential because normal gait is important to healthy lower limbs. The fourth user need is important as the device will be frequently used by the user, so having good durability is a key aspect of the device. The fifth user need came directly from the team's interview with DeSavage. He recommended that the brace be light weight to ensure more comfort for the user. The sixth user need is intended for ease of use. The device needs to be affordable, the seventh user need, so that it is accessible to all that need it. The eighth user need is that the device needs to be customizable for the individual to ensure proper fit.

4.2. Design Requirements, Functions (Specifications)

The design requirements can be found in table 3. The design requirements are essential to the project because they are what the design is built upon. Some of the design requirements are qualitative, however, the majority of the design requirements are quantitative.

Table 3: List of design requirements

Design Requirements
01- The device must lift the patella away from the trochlea to reduce contact between the bones in the anterior direction.
02- The device should oppose the force vector of the patella withstanding up to approximately 500 N, in all directions (medial, lateral, and anterior).
03- The device must fit the dimensions of the user. Range of thigh- 21'' -23.5'' Range of knee- 15''- 17'' Range of calf- 16''-18''
04- The device must permit up to 135 degrees of flexion of the knee
05- Survive a fatigue test of 2,555,000 cycles per year
06- The device must not cause discomfort for the user

The first design requirement is a qualitatively observed requirement. It correlates with the first user need in the previous section. The device must move the patella away from the femur. The next design requirement quantifies the forces that are needed to oppose the patella. These forces were calculated from the literature review. The base user that the team decided to use weighed 150 lbs. The anterior force of the patella on the femur during a squat for the individual is seven times their body weight, as seen in Table 1.

$$150 * 7 = 1050 \text{ lbf} \qquad 1050 \text{ lbf} = 4670 \text{ N}$$

The team rounded up to have the device withstand 5000 N of force. However, this force is distributed across the surface of the patella. To approximate the amount of force needed to lift the patella against the distributed force, the team divided the force value by 10 and estimated the force to be 500 N. This value was used because the anterior force is a distributed load and it is the initial benchmark that the team set for themselves as lifting the patella has not been attempted before. This also posed less risk for the user.

The third design requirement is in reference to the dimensions of the user. There is a range that the device must be in to ensure user comfort. This range is for the thigh, the knee, and the calf as seen in Table 3. In addition to fitting the user, the device must have a normal range of motion. This normal range of motion will enable a regular gait which aligns with the third user need.

The brace must also withstand a year's worth of wear, with the average person taking on average 7000 steps a day, resulting in 2,555,000 steps per year. The final device must withstand

a fatigue test of 2,555,000 cycles so that the brace will last the user for at least a year. In addition to the wear that occurs with walking and other activities, the device needs a wire that can withstand wear.

The final design requirement from Table 3 is that the device must not cause the patient discomfort. This is the second qualitative design requirement. This is important to the entirety of the project because if the device is not comfortable for the user, they will not wear it. This would also result in continuous pain for the user and ultimately the brace would fail.

These seven design requirements are essential to the success of the brace. If the final brace does not fulfill the requirements it will not be an effective brace.

4.3. Important Industry Standards

There are several important engineering standards that the medical device industry relies on for specific technical details and characteristics. All products, systems, and processes that the industry must adhere to these standards. These standards are the guidelines that may be used to ensure that any medical device developed is fit for their intended purpose. This makes certain the minimum performance of any medical device is met as is the safety, repeatability, and compatibility of the medical device.

The main engineering standard used in reference for this prototype patellofemoral knee brace is ISO 22523:2006(en). This ISO standard can be considered the gold standard for lower limb orthoses but there are also many other standards that were referenced throughout the duration of this project. The engineering standards that were referenced when developing test methods for the brace prototype are as follows:

- ISO 22523:2006(en) External limb prostheses and external orthoses — Requirements and test methods
- ISO 13485:2016(en) Medical devices — Quality management systems — Requirements for regulatory purposes
- ISO 10993-1 Biological Evaluation and Biocompatibility Testing of Medical Devices
- ASTM F2808 – 17 Standard Test Method for Performing Behind-the-Knee (BTK) Test for Evaluating Skin Irritation
- ASTM A931 – 18 Standard Test Method for Tension Testing of Wire Ropes and Strand

ISO 10993 and the two ASTM standards were used as references when creating the test methods for this project. They outline the standard procedures used and set the criteria of success in many cases. ISO 10993 covers biocompatibility for medical devices and is important to consider through the design and testing processes. ASTM F2808 details the method for evaluating skin irritation for devices that involve components behind the knee. ASTM A931 goes over the standard method used for evaluating the tensile strength of wires. ISO 13485 was used in a broader sense as a reference when setting up our quality management system. It was used to help create a consensus on the team's definition of risk and what systems to put in place in order to mitigate that risk.

4.4. Additional Considerations

In addition to standards the team had to take other factors into consideration when designing the brace. These considerations include economics, environmental impact, societal influence, political ramifications, ethical concerns, health and safety issues, manufacturability, and sustainability.

4.4.1. Economics

The economics of the project vary upon final result. The team could partner with an established bracing company, which would have more connections and systems in place to commercialize the brace in the market. This would increase the economic value of the device. It might limit the influence the team has over the product.

4.4.2. Environmental Impact

The team has also thought of the environmental impact of their device. The team considered the long-term degradation of the brace after the user has finished using it. The team hopes to use materials that would degrade without negative impact on the environment or would be easily recyclable, but that is to be developed after a final working prototype is decided upon.

4.4.3. Societal Influence

The societal influence of the brace is high. The team sees a value in marketing the brace. The product could greatly impact the society. The team believes that selling the completed brace will help people with anterior knee pain live a healthier and more pain free life.

4.4.4. Political Ramifications

The political ramifications of the device are minimal. The team hopes that the brace will enter the global market with the aid of an established bracing company. The goal of the device is to help as many people as possible, regardless of their socioeconomic status.

4.4.5. Ethical Concerns

The ethical concerns of this project take place during testing. The team used a goat leg as an analog to a human leg. Additionally, the team plans on conducting human studies. The team needs to take precautions when testing the brace on human subjects to minimize risk. Fortunately, the brace poses minimal risk to humans due to the non-invasiveness, lack of other potential hazards, and ease of removability.

4.4.6. Health and Safety Issues

The goal of the device is to improve the quality of life of individuals with anterior knee pain. The team wants to improve the lives of people with knee pain. The health and wellbeing of these individuals will increase with the use of the brace.

4.4.7. Manufacturability

The team would like to pursue avenues for manufacturing the device. The device should be easy to manufacture. This is something that needs to be considered in detail after the final prototype is completed.

4.4.8. Sustainability

Finally, the team would need to create sustainable manufacturing processes when developing the device. The team hopes to minimize the environmental impact of the development of the brace.

4.5. Conceptual Designs

After preliminary research the team decided to create designs separate from each other. Each team member presented their conceptual designs so that they could be discussed, and a final design could be chosen.

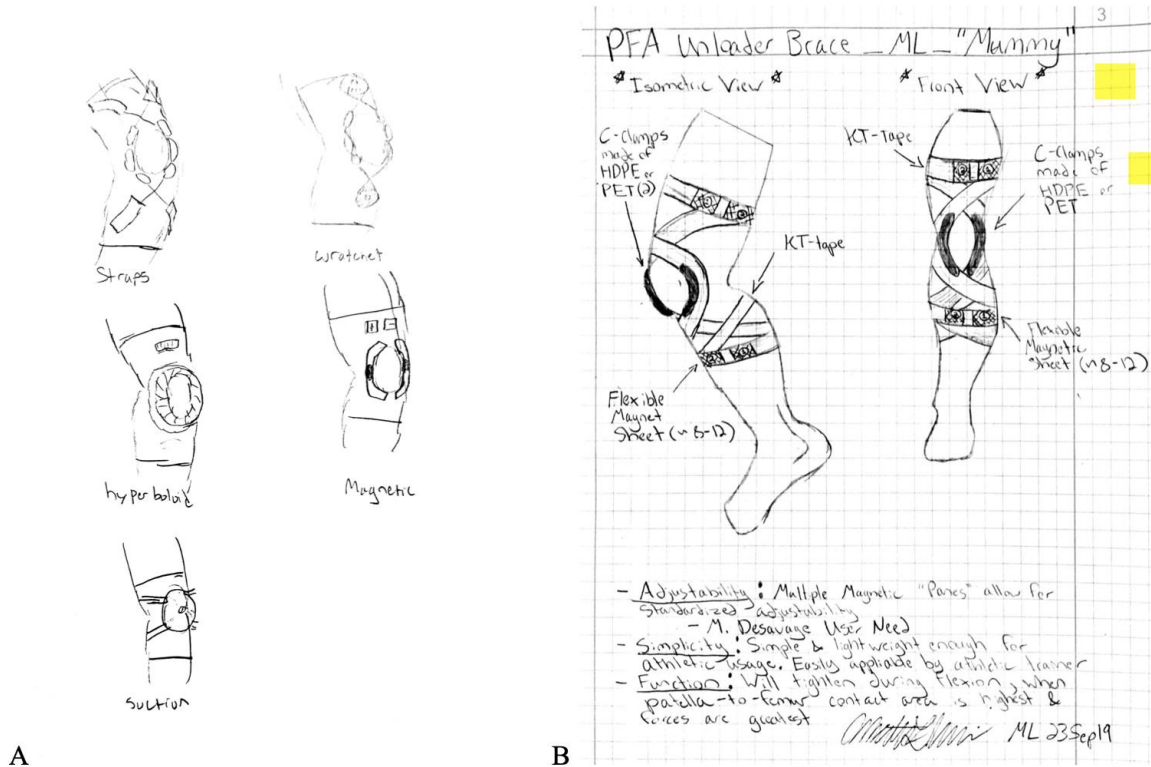

Figure 14: Example of conceptual design 1

Figure 14 shows some of the initial conceptual designs the team created. Figure 14A shows five conceptual designs. The first is using wires and a c-clamp to pull up on the patella. The forces in the design would be created using adjustable straps. The second design is similar to the first, except that instead of using straps, it uses a ratcheting system. The hyperboloid design concept is to be turned like a ratchet and as it does this, it wedges under the patella. The magnetic conceptual design is using a magnetized c-clamps to wedge under the patella and pull it up. The final design of figure 14A is the suction concept. In this design there would be a suction device pulling up on the patella, reducing its contact with the femur. Figure 14B is a conceptual design named the mummy. This uses a combination of straps and c-clamps to pull up on the patella as well as magnets to adjust the pull of the leg.

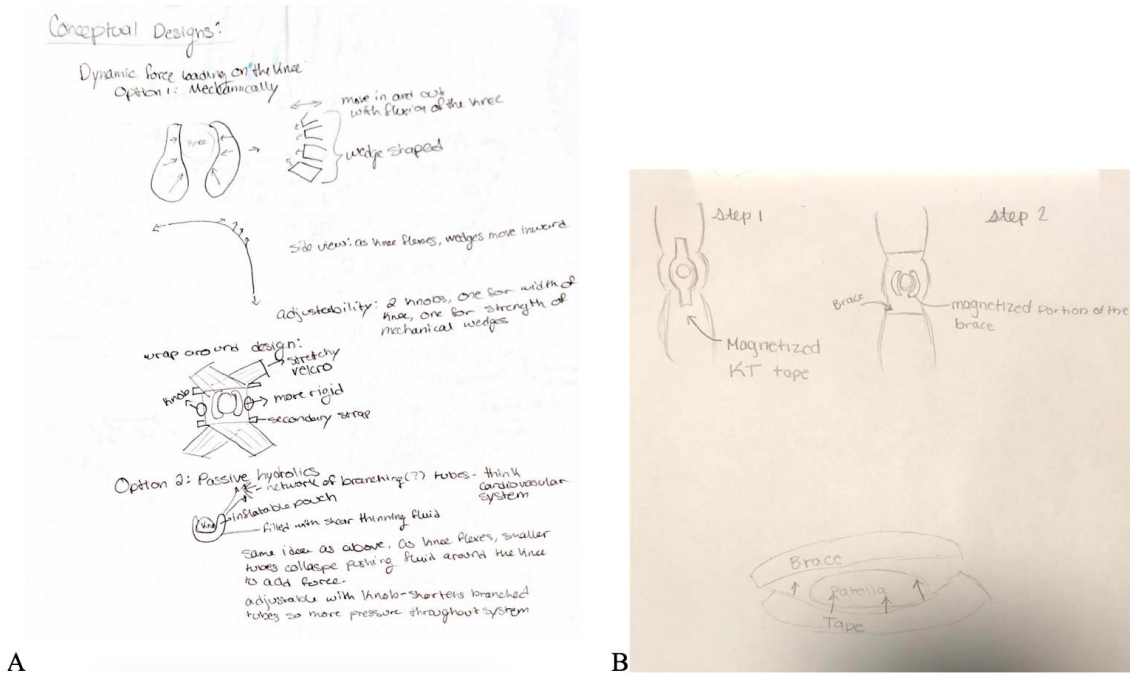

Figure 15: Example of conceptual designs 2

Figure 15 shows additional conceptual designs created by the team. Figure 15A shows a design that mechanically pushes up on the patella with knobs. This design is similar to the ratchet design with the knobs acting as ratchets in different locations. The final conceptual design that the team created is seen in Figure 15B. This design uses magnetic kinesiology tape (KT tape) to grip the knee. The brace is then placed on the patient and has a magnetic base that pulls up on the KT tape, distending the patella.



Figure 16: Baseline design- DonJoy Tru-Pull Sleeve Advanced System [15]

The team conducted a study to see what types of braces already existed on the market. As there were no braces that were specifically intended for patellofemoral arthritis, the team looked at a brace that could be used for similar conditions. The DonJoy Tru-Pull brace seen in Figure 16 was chosen. This design was used as a baseline that the team's conceptual designs were compared to.

4.6. Design Selection

After the initial designs were made the team created a pairwise comparison chart to determine the importance of each user need. The team interpreted the user needs from section 5.1.2. as the initial column of Table 4. The user needs were then given a ranking compared with one another in the below pairwise comparison chart.

Table 4: Pairwise Comparison Chart

	Reduce Pain	Non-restrictive	Fatigue Life	Less Material	User Friendly	Affordable	Adjustable	Avoid abrasion	Total
Reduce Pain	x	1	1	1	1	1	1	1	7
Non-restrictive	0	x	1	1	0	1	0	0	3
Fatigue life	0	0	x	1	.5	1	0	0	2.5
Less material	0	0	0	x	.5	0	0	0	.5
User friendly	0	1	.5	.5	x	.5	.5	0	3
Affordable	0	0	0	1	.5	x	0	0	1.5
Adjustable	0	1	1	1	.5	1	x	0	4.5
Avoid Abrasion	0	1	1	1	1	1	1	x	6

A pairwise comparison chart compares user needs to one another and ranks each by their level of importance to the ultimate design. The “X”s represent boxes that are comparing user needs to themselves, making them unnecessary for the pairwise comparison chart. For each box, the user need on the left axis is compared to the user need on the upper axis. If the left axis user need is more important than the upper axis user need, then a “1” is placed within the box. If the left axis user need is less important than the upper axis user need, then a “0” is placed within the box. If both user needs are deemed equal in importance, then a “0.5” is placed within the box. After every box has been filled, the numbers in each row are summed up. The sum of each row is

equivalent to the rank of importance of the user need in that same row. Based on the comparison chart, reducing pain is the highest weighted factor.

Table 5: Pugh Comparison Chart

	Weight	Baseline (DonJoy Tru-Pull)	Mech Dynamic Force Loading	Passive hydraulic Force Loading	Elasto	MagniCe	Mummy	Straps	Ratchet
Reduce Pain	7	0	1	1	1	1	1	1	1
Avoid abrasion	6	0	0	0	0	0	0	0	0
Adjustability	4.5	0	1	1	0	1	0	0	1
Non-restrictive	3	0	1	1	1	1	-1	1	1
User Friendly	3	0	-1	-1	0	0	0	0	1
Fatigue	2.5	0	-1	-1	1	0	0	0	0
Affordable	1.5	0	0	-1	0	0	1	0	0
Less Material	.5	0	0	0	1	1	1	0	-1
Total		0	9	7.5	13	15	6	10	17

Using the results of the pairwise comparison chart, the various conceptual design ideas were compared to one another using a Pugh Comparison Chart. A Pugh Comparison Chart evaluates whether or not a conceptual design can satisfy a given weighted factor. If a conceptual design is expected to positively affect a given factor, it is given a value of “1”. If a conceptual design is expected to negatively affect a given factor, it is given a value of “-1”. If the conceptual design is expected to have no effect on a given factor, it is given a value of “0”. The given values

for each factor are then multiplied by the weight obtained from the Pairwise Comparison Chart. The products for each factor are then summed for each individual conceptual design. The design with the highest score was pursued.

4.7. Modeling

4.7.1. Conceptual Design Selection and Rationale

Based on the Pugh comparison chart, the team was able to conclude that the best conceptual designs compared to the DonJoy Tru-Pull were the Ratchet, the MagniCe and the Elasto which received scores of 17, 15 and 13, respectively, based on Table 5. The team decided to create more detailed conceptual designs of these three designs as shown in Figure 17.

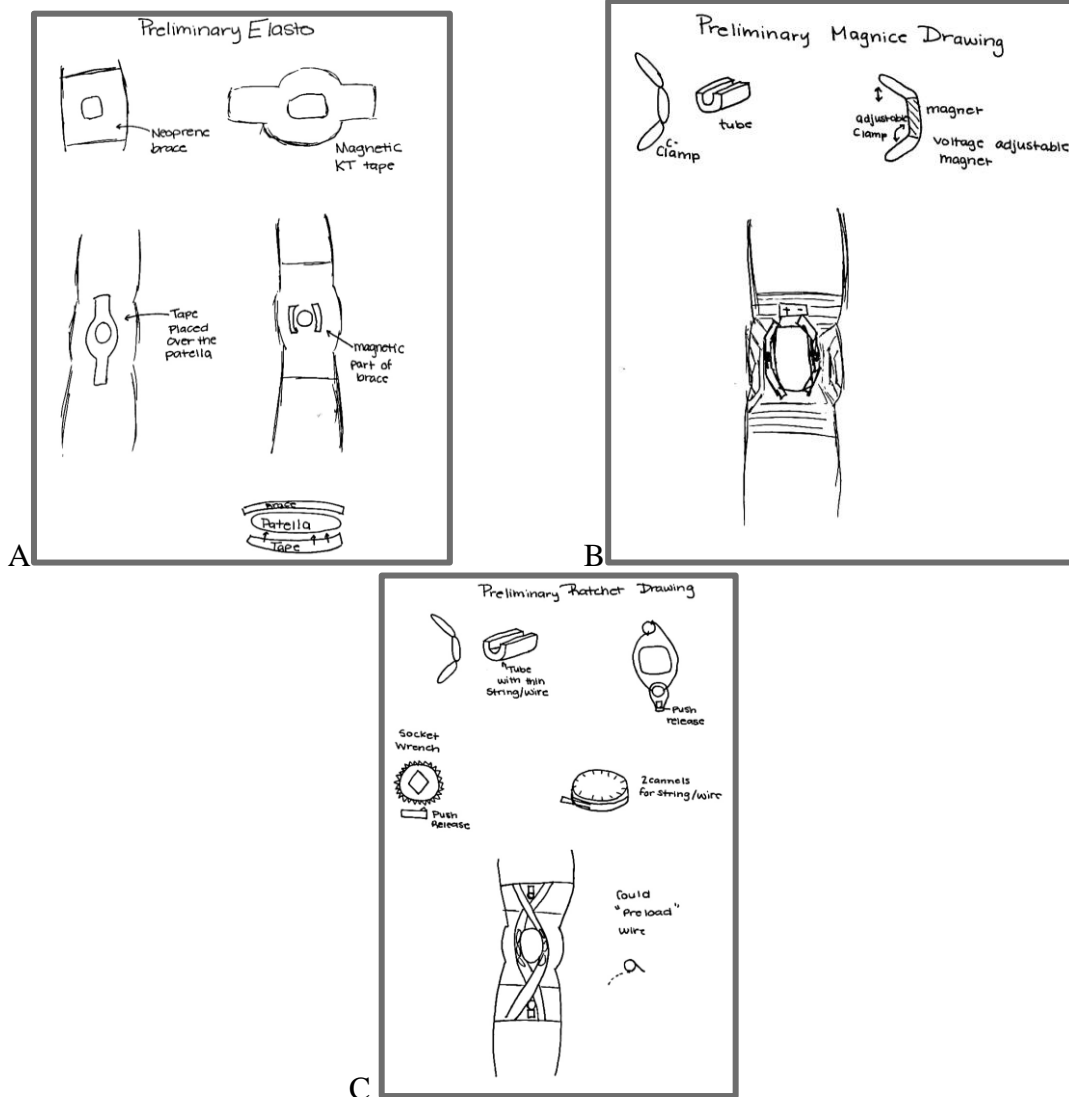

Figure 17: Top 3 designs selected from Pugh comparison chart

The first preliminary design that was discussed was the Elasto. This design uses magnetic KT tape to wrap around the patella. The tape would wrap around the patella and a flexible neoprene brace would be placed over the knee. There would be magnetic sections around the patella in the brace, which would pull up on the patella. This brace is seen in Figure 17A.

The second preliminary drawing is shown in Figure 17B. This is for the Magnice design, which uses magnets to wedge under the patella. The magnets would be aligned in a c-clamp fashion with an adjustable magnet. The magnet would have an external remote that would be used to increase and decrease the magnetism, which would pull up on the patella.

The preliminary drawing for the ratchet design is seen in Figure 17C. This design received the highest score in the Pugh comparison chart. This design uses a thin string and

covered by a thin tubing creating a c-clamp around the patella. The thin string connects to the ratchets on the rigid base at the thigh and the shin. The main concept of this design is that the ratchets would pull the string to tighten around the patella and the c-clamp would wedge itself under the patella. This could result in the patella being lifted away from the femur reducing patient pain. Ultimately the ratchet device was selected, and the team developed different designs.

4.7.2. CAD History

The design of the prototype knee brace was created through iterative design and testing. There have been four generations of complete prototypes created. The generation designs are detailed below in their respective full assembly drawings. The individual drawings for each subassembly and part, for each generation, can be found in Appendix II.

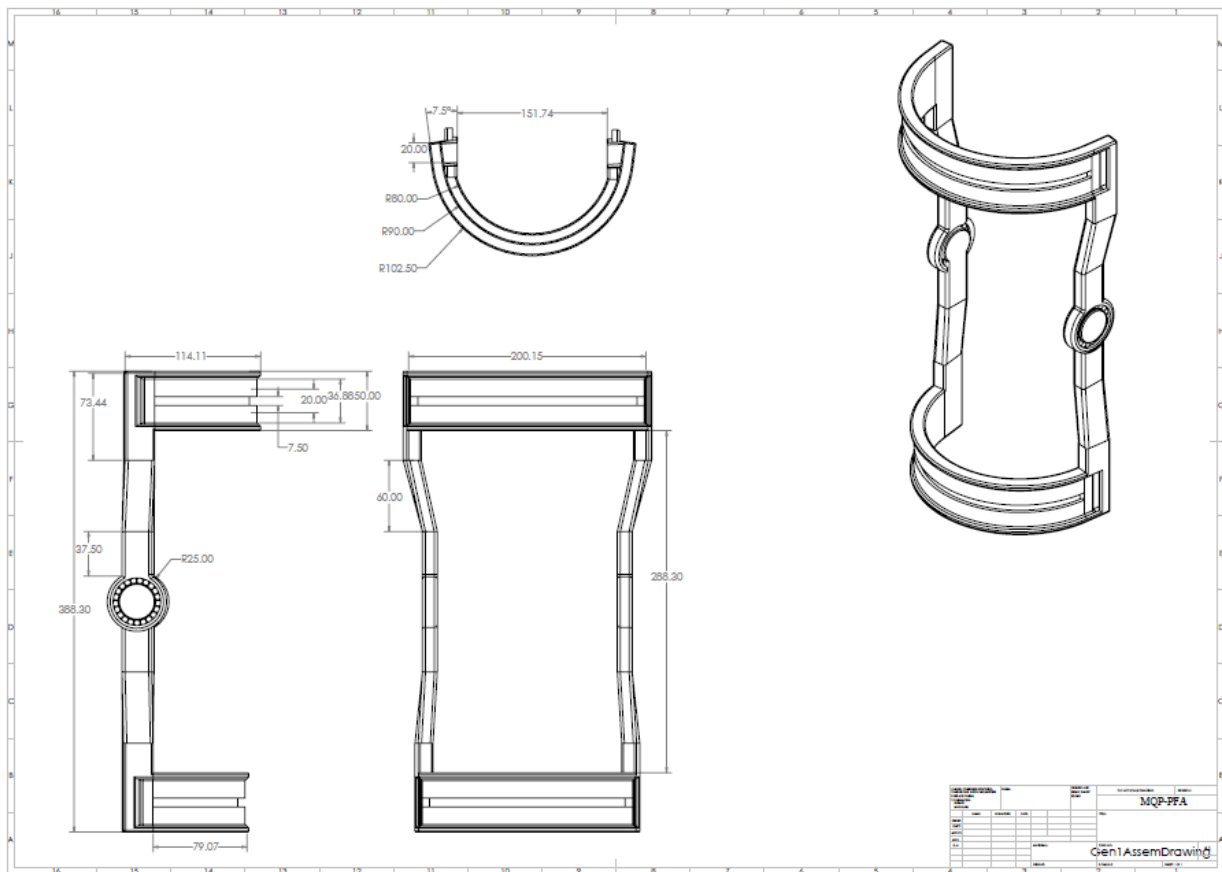

Figure 18: Generation 1 Full Rigid Base Assembly Drawing

The first generation of the prototype consisted of a rigid base and external components. As shown in Figure 18, the rigid base consisted of two different 12.5 mm thick circular bands

which spanned a total of 165 degrees of their respective inner radii: 90 mm for the thigh, and 80 mm for the calf. These two bands were connected to a ball bearing hinge joint by twisting connector pieces. The method of attachment between parts was press fit. The span between the parallel hinges was 150 mm. The hinges were designed as ball bearing joints.

The upper and lower bands had features to allow straps to wrap around the leg and secure to the rigid base as well as channels through the front of the bands for attachment. The original design intent was to create moveable platforms by which to attach the ratcheting systems and the anchors of the wires. Upon initial iterative printing of these parts, however, several concerns were raised about the design such as the thickness of the brace, the lack of any real need to move the ratcheting system, and the difficulty in assembling the hinges with the finicky ball bearings. These concerns stemmed from the design of the rigid base but also the limitations of the equipment we were using and the tolerancing ability of the available 3D printers.

All parts for the generation one rigid base were created through additive manufacturing using fused deposition modeling (FDM) and the thermoplastic extrusion technology of the Makerbot Replicator+. Initial parts were made using PLA as the print material. The only exception was the ball bearings which were ordered separately due to the need for more precise tolerancing than our 3D printers allowed.

The same material and printers were used to test individual parts as the 2nd generation of the rigid base was developed. Once the brace design was finalized, one of the two Makerbot printers was transitioned to printing with Makerbot Tough Filament, which is a more durable thermoplastic that is more suited to withstand the expected loads.

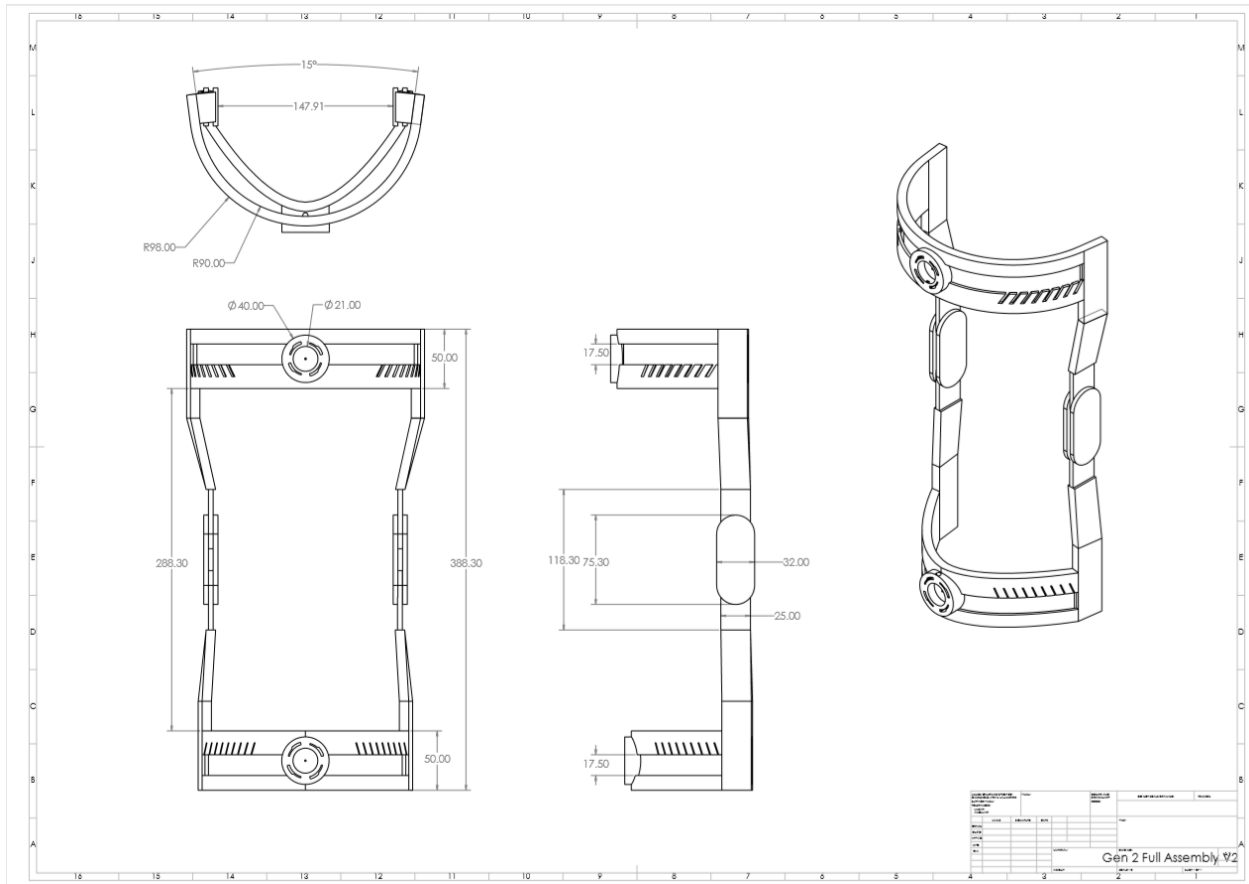

Figure 19: Generation 2 Full Rigid Base Assembly Drawing

The second generation of the rigid base design worked on addressing the concerns of the previous generation. Overall, the thickness of the base was reduced to 8 mm. As seen in Figure 19, the rigid base now incorporated within it the anchoring system and the platform for the ratchet to attach to. It also shifted from the unnecessarily complicated ball bearing hinge to a simpler pin-based hinge joint. Furthermore, to reduce the need for joints and adhesives, the connector parts were combined with the upper and lower parts. The total size of the new combined parts fits into the tray and into the capabilities of our 3-D printing technology. The last change that was made was to the strap securing the brace to the thigh and calf. Instead of connecting to the end of the brace, it can now wrap all the way around through the upper and lower parts, to connect at the other side, allowing for a more comfortable and secure fit.

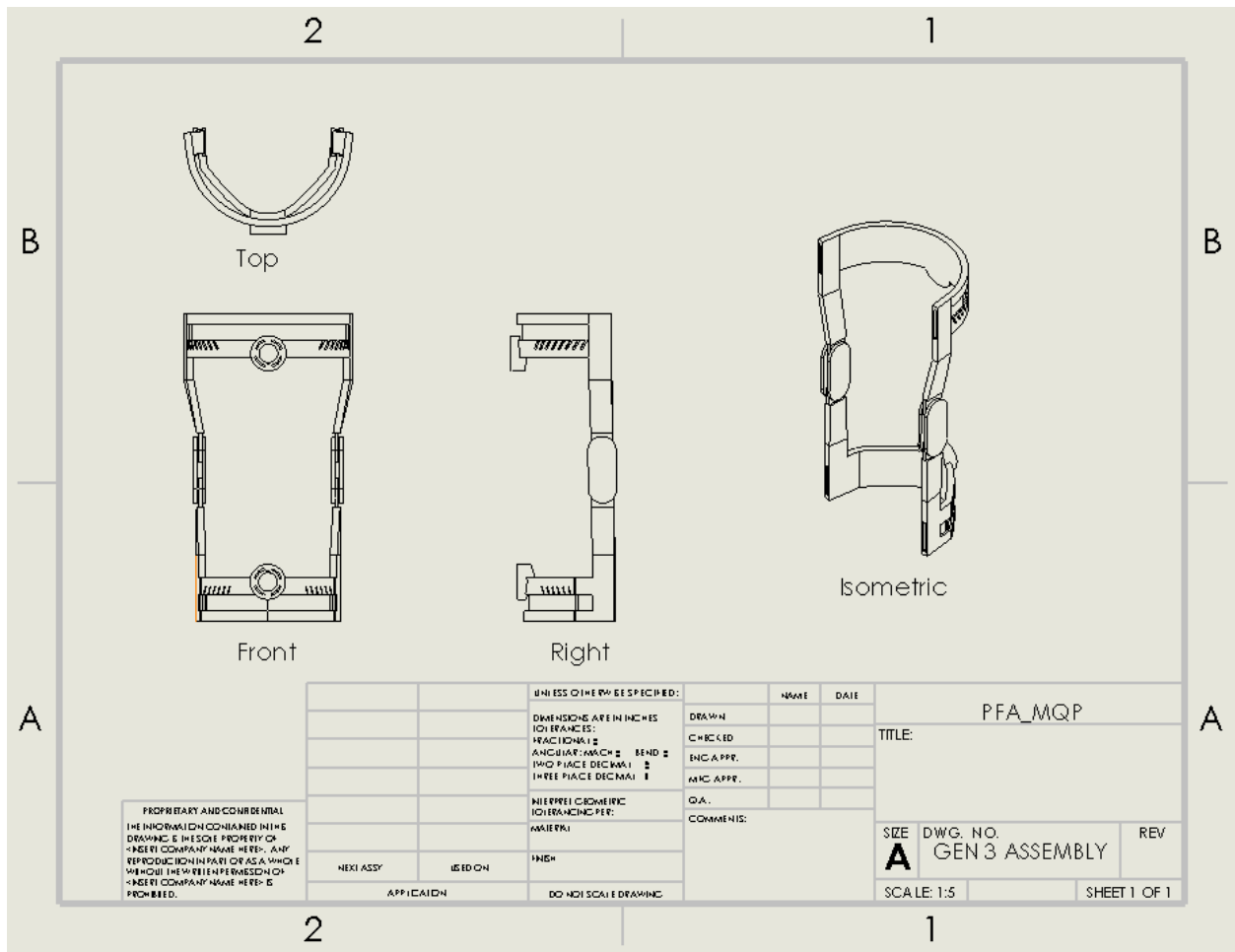

Figure 20: Generation 3 Full Rigid Base Assembly Drawing

As seen in Figure 20, the third generation of the rigid base design is nearly identical to the generation 2 rigid base design with regards to features. The only difference was minor dimension adjustments for enhanced form fitness for human legs. The fourth generation of the rigid base design is shown below in Figure 21. The details of this design will be covered in section 6.7.4.

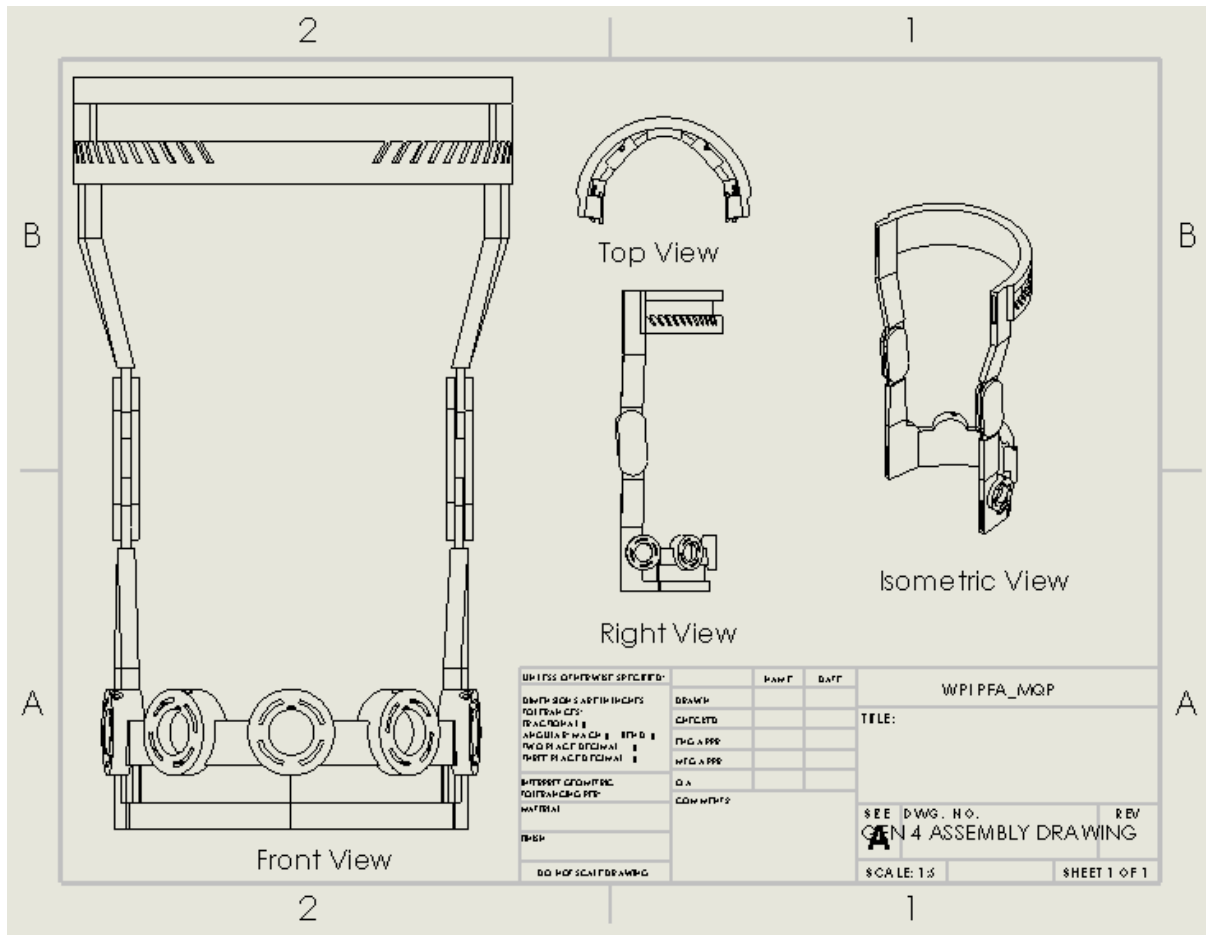

Figure 21: Generation 4 Full Rigid Base Assembly Drawing

4.7.3. Design Rationale

During the design process, there were a multitude of choices that had to be made. These choices could be external to the design of the brace and ranged from which 3D modeling software to use, to how the parts would be manufactured, to what material would be used and for which part. These questions could be answered with relative confidence. The team would use Solidworks because of the large amount of combined experience of the team members. The team would manufacture the parts using additive manufacturing to allow for quick changes and quick realization to our prototype. The team would use the toughest and best suited thermoplastic that was compatible with our 3D printer, the MakerBot Replicator+.

However, there were even more choices that had to be made when developing the design concept into the final design prototype. These decisions did not always have a clear answer. In many cases, the team members working on the design would make a case for each side of the

argument and go with the one which had the most advantages or was most in line with the design requirements.

For example, when deciding the thickness of the brace for the second generation, it was found that the thickness of the assembly was bulky, cumbersome, and could potentially interfere with normal gait motion on the inside of the thighs. The immediate response was to make the brace thinner, but with this came some drawbacks. If the thickness of the brace were to be reduced, the press fit connections of the first generation would suffer. This potential flaw influenced and helped propel the resulting decision to eliminate as many connections as possible in between parts. This would mean printing the upper and lower parts with the connectors attached. In the end, this allowed for two positives to come out of the design thought process from an apparent negative.

There were other ideas which could only be tested, and not rationalized, such as the method of attachment for the straps to the rigid base. Generation One had a strip of plastic allocated for this on either side of the upper and lower parts, but after printing and trying out this system, it was found that the straps were too raised from the individual's leg and introduced some discomfort. To rectify this, a channel for the strap to wrap around the inside of the upper and lower parts was created in the next iteration of the brace. This system of iterative prototyping was helpful in coming to design decisions when there were no clear answers. The design rationale behind each part is described by their respective drawings in Appendix II.

4.7.4. Final Design Function

Beyond the rigid base, there are other components to the brace prototype. Specifically, there are three component types: a ratchet, a wire, and a set of c-clamps. In Figure 22 below, the ratchets are represented in red, the wires in blue, and the c-clamps in magenta. The orange object is representative of the patella.

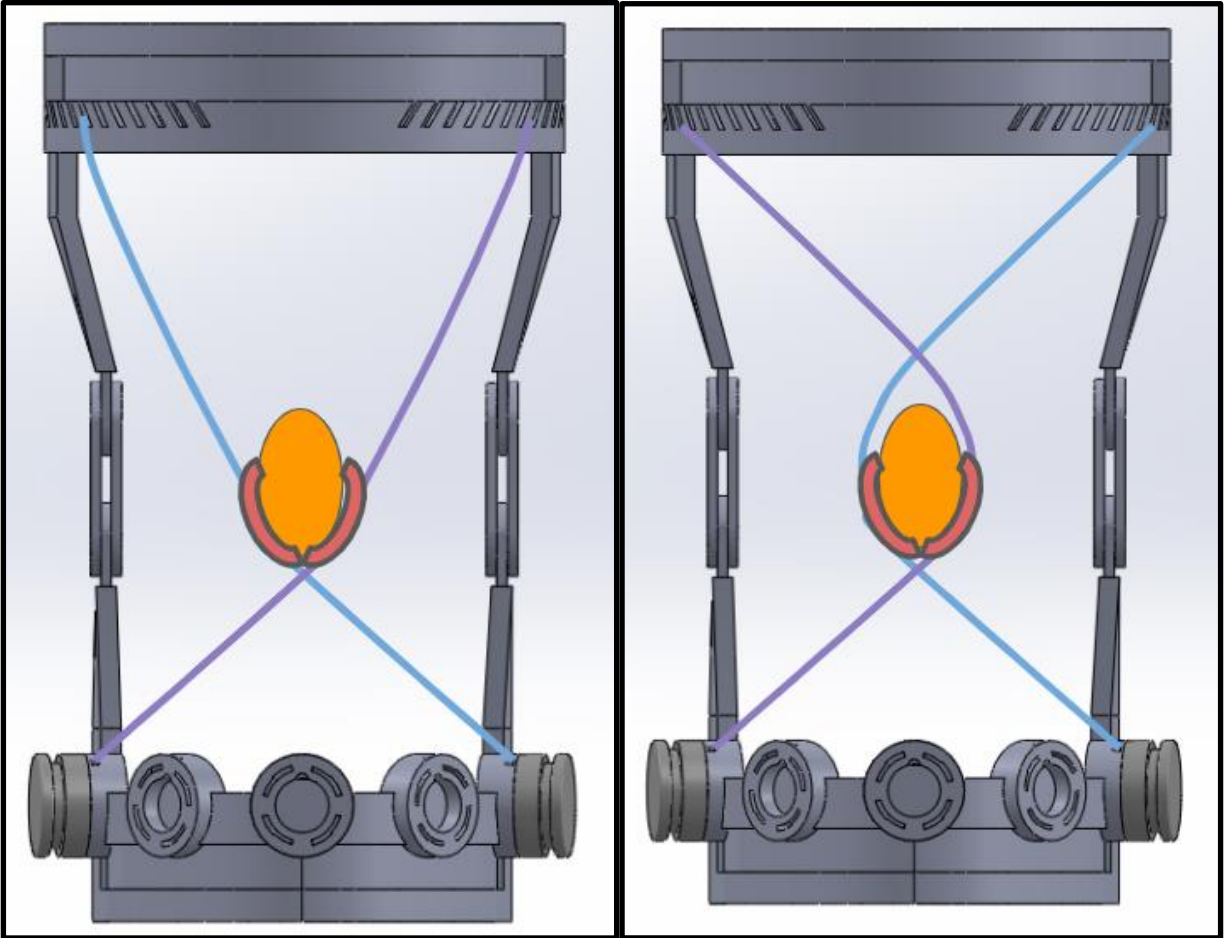

Figure 22: Generation 4 Brace Prototype Wire Orientations. Left image shows the “across side” orientation, while the right image shows the “same side” orientation.

Wire orientation included two variations: one where the wires from each ratchet anchor themselves on the same side of the wire’s ratchet location, and one where they anchor themselves on the opposite side, called the “same” and “across” orientations respectively. The end of the wire anchored to the rigid base will be capped by a bent aglet, such that it is anchored behind the channel of the rigid base. Around the middle of the wire, by the patella, will be a set of c-clamps. The function of these c-clamps is two-fold; first they must secure the patella, and second, they must aid in channeling the forces of the wire in getting underneath the patella and providing lift. The forces in the wire will be generated and held through the actuation of the ratchets attached to the upper and lower parts of the rigid base.

The H-series ratchet design of the BOA Company was chosen for the ratchets. These ratchets were determined by the team to be the strongest and most durable ratcheting systems of the desired size currently on the market. The team felt that going with a pre-made system was going to be better designed as well as more time and cost effective. The wire that was chosen

was the metal wire provided by BOA due to the compatibility of the wire with the ratchet design and the expected mechanical properties being well above the required range ~2-6 GPa of tensile strength. The ratchet model number is the H3, Dial G, SS2 and the wire model is Lace, SS2, 140cm.

There are a few potential designs of c-clamps that were created which were evaluated in one of the test methods. C-clamp design included 3 different types: the “Hard” clamp type was 3D printed out of PLA, the “Soft” type was made from a compressible pencil grip, and the “Hybrid” type was a combination of the “Hard” and “Soft” types. One of the last additions to the design was that of rubber bands. Holes within the connectors and the clamps allowed for rubber bands to attach the c-clamps to the rigid base. This function would potentially allow for the stabilization of the c-clamps when in the across orientation. An example of this is shown in Figure 23 below.

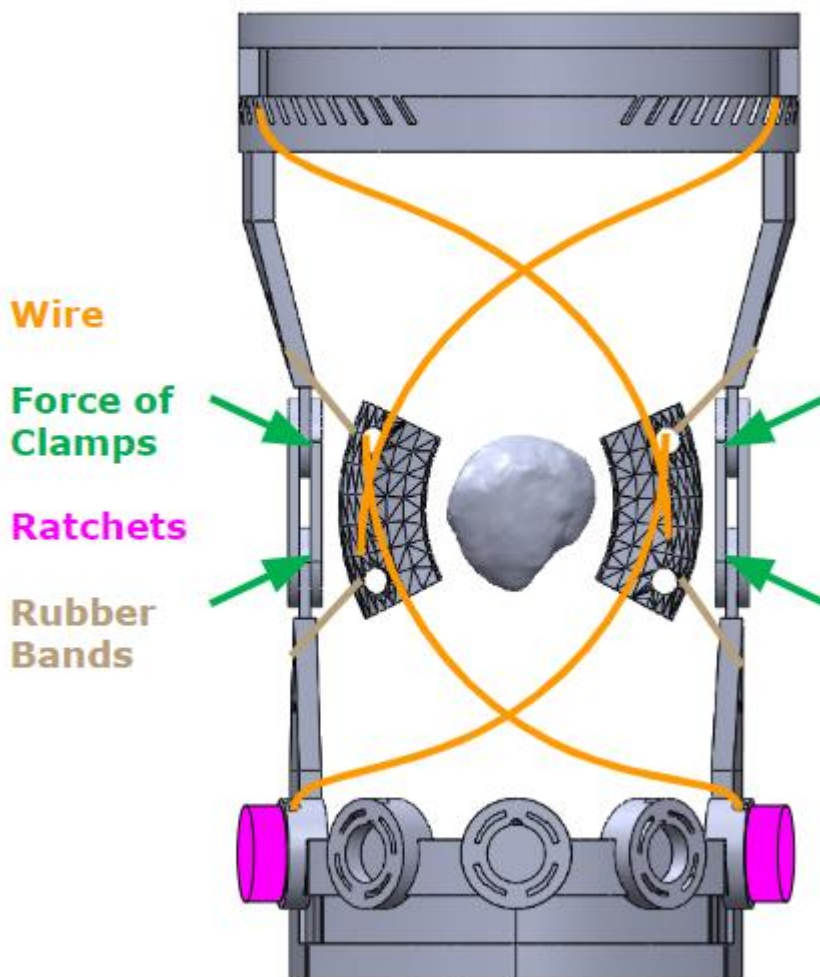

Figure 23: Generation 4 Rubber Band Function

4.8. Test Methods and Traceability

4.8.1. Test Methods

Over the course of the project, the team was able to complete and develop test methods to test against the design requirements. In total, the team created 10 test methods, identifiable by the acronym “TM-”, to complete their goals. The test methods were numbered in the order that the team created them.

TM-01 is broken up into two parts; one, a CT scan test, and two, a kinematic tracking test. The CT test (TM-01A) consists of the brace being put on a goat model and actuated. The scan shows the knee with and without the prototype under various brace configurations without flexion. The objective of this test method was to visually show if the patella is removed from the femur. The second part of this test, TM-01B, utilizes kinematic tracking sensors to collect 3D positional data on the movement of the leg. The sensors are fixed to the femur, the tibia, and the patella. The movement of the patella is analyzed using the PiMgr software. TM-01 can be found in Appendix III.

Before conducting the goat leg test methods, a veterinarian was consulted about the preparation of the goat leg. The team was able to order one goat leg in advance which a veterinarian helped us in a practice session on how to prepare the goat leg for our brace and for our test methods.

The second test method involves the use of the software OpenSIM, with the Open Knee platform, which is aimed to provide an accredited three-dimensional finite element representation of the human knee joint. This software allows the team to simulate forces on the knee joint, and obtain the theoretical response, which is useful in more accurately estimating the expected forces generated by the brace prototype. TM-02 can be found in Appendix III.

The third test method is important to ensure that the knee brace fits the user. The brace needs to fit within the specified dimensions, especially around the thigh and calf. This test method helps to ensure user comfort. TM-03 can be found in Appendix III.

The fourth test method is used to measure the range of motion of the user. This is measured using a goniometer. The maximum and minimum angle of the brace are measured in

order to ensure normal motion. This is essential because it allows the user to maintain normal gait motion. TM-04 can be found in Appendix III.

The fifth test method consists of a fatigue test for the device. This is important because the device is intended to withstand a year of use. The fatigue test is conducted using a custom test fixture incorporating a motor that cycles the brace flexion and extension. TM-05 can be found in Appendix III.

The sixth test method is important to ensure the strength of the wire in the device. The wire needs to be strong enough to withstand the tension that is produced by the ratchet. The wire must also be strong so that it can pull up on the patella. TM-06 can be found in Appendix III.

The seventh test method is a human comfort test. In this test, the user is asked a series of preliminary questions. After the questions are complete, the user wears the brace in contact with bare skin for 5 hours. After the 5-hour test, the user will be asked a follow up series of questions in regard to comfort and skin irritation. This test is important because it determines the comfort the user has when wearing the brace. TM-07 can be found in Appendix III.

The eighth test method involves the use of Fujifilm to measure the pressure and contact area between the patella and femur of the goat model. The Fujifilm is placed between the patella and femur. The knee is bent so that the film is able to measure the pressure. In addition to having a qualitative measure of pressure, a quantitative measurement will be generated using the Instron at different forces and different Fujifilms. TM-08 can be found in Appendix III.

The ninth test method evaluates the effectiveness of the c-claps on the brace. The c-clamp designs are analyzed in another human subject test. In the test, a user wears the two c-clamp designs and completes a list of actions. The user then answers questions relating to the different clamps and their experience. Additionally, Fujifilm will be used to measure the pressure that the c-clamp designs apply to the skin. These two tests help to determine the optimal c-clamp design to use in the brace. TM-09 can be found in Appendix III.

The last test method, TM-10, evaluates the relationship between the force applied by the wire to the degree of rotation of the ratchet. For this test, a human subject wears the brace, attaches a force gage onto the wire, and collects data every 90-degree rotation of the ratchet. This test helps to understand how much force the ratchet can exert on the wire while on the user. TM-10 can be found in Appendix III.

4.8.2. Traceability

The test methods from the previous section were matched with the design requirements they aim to test against. Table 6 shows the relationship between the design requirements and the test methods.

Table 6: Design Requirements and Test Method Traceability Matrix

Design Requirement	Test Method
01- The device must lift the patella away from the femur to reduce contact between the bones	TM- 01 TM- 08
02- The device should oppose the force vector of the patella withstanding up to approximately 500 N	TM-02 TM-06
03- The device must fit the dimensions of the user Range of thigh- 21'' -23.5'' Range of knee- 15''- 17'' Range of calf- 16''-18''	TM-03
04- The device must permit up to 135 degrees of flexion of the knee	TM-04
05- Survive a fatigue test of 2,555,000 cycles/ year	TM-05
06- The device must not cause discomfort for the user	TM-07 TM-09

Based on Table 4, each design requirement is covered by at least one test method. Design requirement 1, or DR-01 is associated with TM-01A, TM-01B and TM-08. These test methods help the team evaluate if the brace reduces contact between the patella and the femur. DR-02 is associated with TM-02, as the simulation from OpenSIM can predict the forces on the patella and TM-06 the tensile test of the wire. DR-03 is associated with TM-03, as the test is specific to ensuring the fit of the brace. DR-04 is covered by TM-04, which measures the angle that is produced by the brace. DR-05 is associated with test method TM-05. This test method focuses on evaluating whether or not the brace can withstand a fatigue life of a year. DR-06 is authenticated by test method TM-07 and TM-09. These test methods are user based to give the best indication of user comfort.

5. Verification and Validation

Upon completion of the tests the team created an order of completion Figure 24 to better visualize the tests.

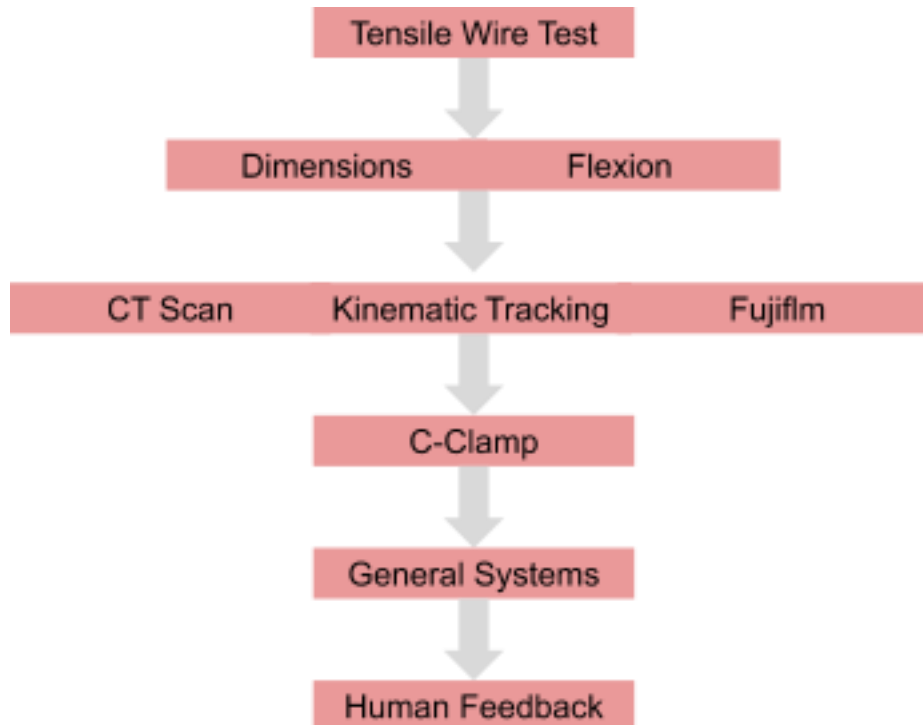

Figure 24: Order of test completion

5.1. Tensile Wire Test

The first test that the team conducted was the tensile test of the wire. The purpose of this test was to determine the yield strength of the wire. The wire needed to be strong enough to withstand the forces created by the brace. Based on the design requirements the wire should exceed a yield stress of 500 N.

When testing, the team analyzed three wires of the same type. The wire needed to be specific to the ratchet and have a diameter of 1/32 in. The team used three segments of one wire and tested them in the Instron 5544. The data collected from the tests is organized in Table 7.

Table 7: Tensile Wire Test Results

	Load at Failure (kgf)
Wire 1	59.05
Wire 2	50.09
Wire 3	65.28
Average	58.14

An example of the load vs. extension curve can be seen in Figure 25 For a full representation of the data see Appendix IV.

Load vs. Extension: Wire 1

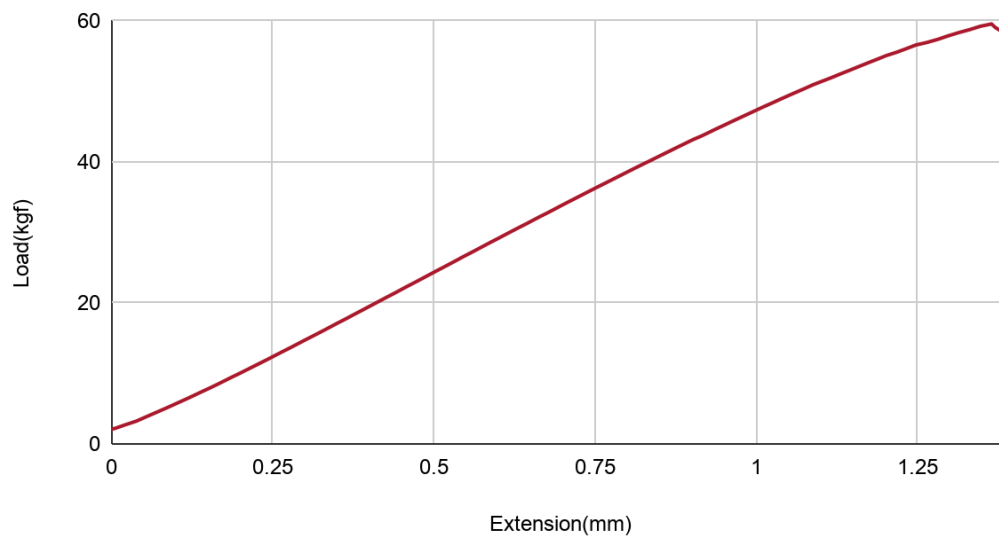

Figure 25: Example of the wire break

The average break of the wire was 58.13 kgf which is equal to 570 N. This exceeds the 500N design requirement that the team was following. This verified that the wire will withstand the forces needed in the brace.

5.2.Dimension Test

The next test conducted by the team was the measurement of the dimensions of the brace. Since there were many design iterations, the team saw the need for this test to verify that the brace maintained the sizing dimensions proposed in the design requirements. For reference, the team used the dimensions range of a standard “large” DonJoy brace. The team assumes that, since this brace is off the shelf, the brace dimensions should be designed to fit most if not all people. The team used a tape measure to measure the interior side of the brace components of the thigh and shin. This measurement can be seen in Figure 26.



Figure 26: Measurement of the brace dimensions

The values were doubled to show the full circumference of the brace and are compared to the DonJoy in Table 8.

Table 8: Brace Measurements

	Expected Range	Measured
Thigh	21''-23.5''	25''
Calf	16''-18''	19.625''

Based on the table, the brace created was slightly bigger than the expected range. One of the reasons for this may be because several design iterations were made to ensure fit to the first human test subject, whose dimensions were larger than those specified by DonJoy.

5.3. Flexion Test

Similar to the dimension test, the flexion capability of the brace was measured. The team used a goniometer to identify the angle produced by the brace. Figure 27 shows the measurement of the flexion.

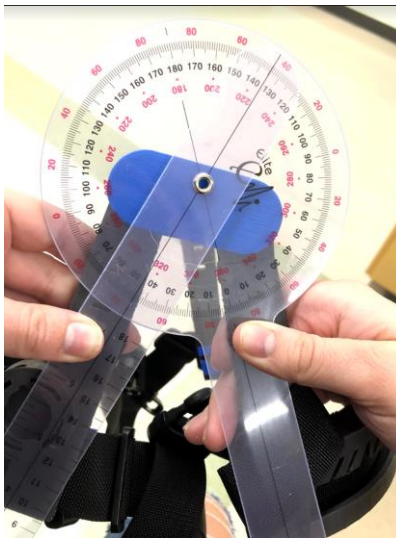

Figure 27: Measure of flexion

The normal range of flexion in the knee joint is 135° . The team wanted to ensure that the user would be able to use the brace in normal movement. When measured the brace was able to reach and exceed the normal range of flexion.

5.4. CT Test

The first test that the team conducted using the goat leg was a CT scan. The team first dissected the goat leg so that it was as analogous to the human leg as possible. The leg was then placed in saran wrap to be put into the scanner. There were 11 scans taken in total during the testing as seen in Table 9. The team was hoping to complete all the possible configurations but could not because of time constraints with the necessary equipment. As each scan took approximately 20 minutes to complete and some configurations needed to be rescanned, the overall time the team had with the CT scanner was limited.

Table 9: CT Trials Conducted

Trial #	Wire Orientation	C-clamp Type	Ratchet Level
1	No Brace	N/A	N/A
2	Brace	N/A	N/A
3	Across	Hard	Secure
4			90 degrees
5			180 degrees
6	Same	Hard	Secure
7			90 degrees
8			180 degrees
9	Across	Hybrid	Secure
10			90 degrees
11			180 degrees

In order to compare images from each scan, the same cross section had to be selected. The team created a systematic way of identifying the same cross section for every scan. The cross sections of the patella were measured in every scan and consistency was kept in those measurements throughout. An example of the cross-sectional measurement can be seen in Figure 28. Additionally, the area of the patella was measured using ImageJ, an image processing tool commonly used for measurements in the biomedical industry. The areas were compared for all the scans to ensure that the same cross section was being analyzed.

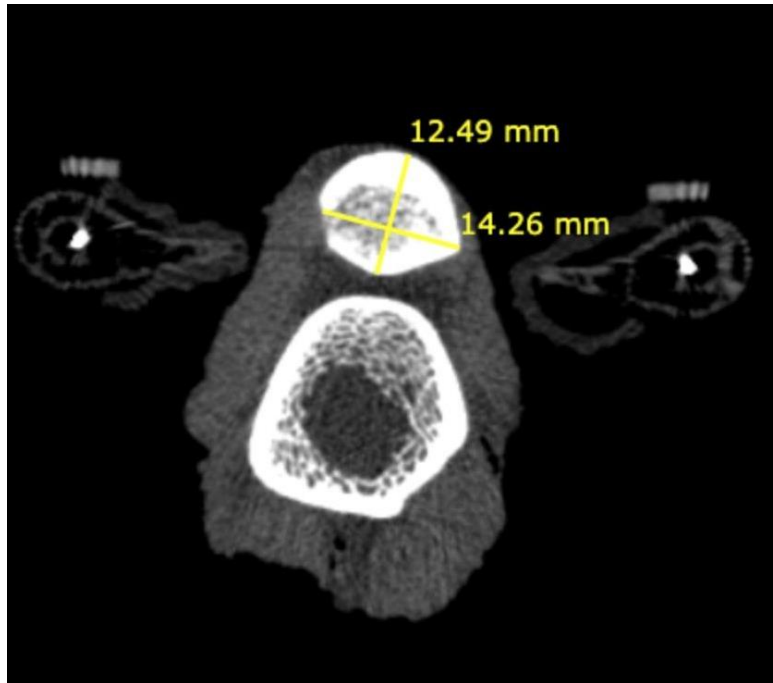

Figure 28: The cross-sectional measurement of the patella.

After this, the medial and lateral distance was measured between the patella and the femur. This measurement is indicated by the blue line in Figure 29. The red line in Figure 29 indicates the middle distance measured between the patella and the femur. To see all the analyzed scans, see Appendix IV.

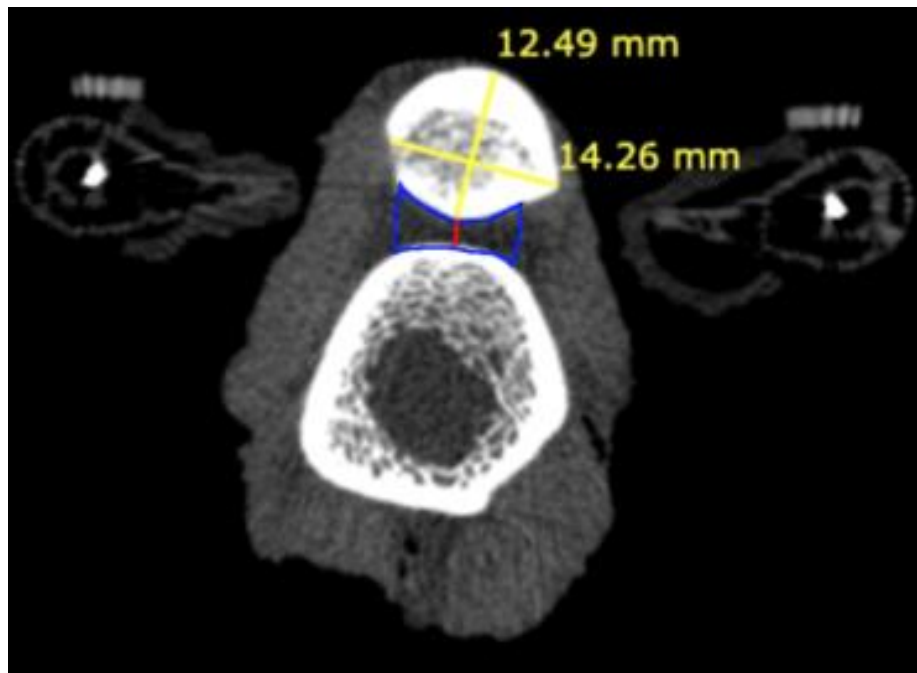

Figure 29: The measurements taken between the patella and femur

Once all the measurements were taken using Image J, they were recorded in an excel document and the scans were all compared. The compared data can be seen in Figure 30.

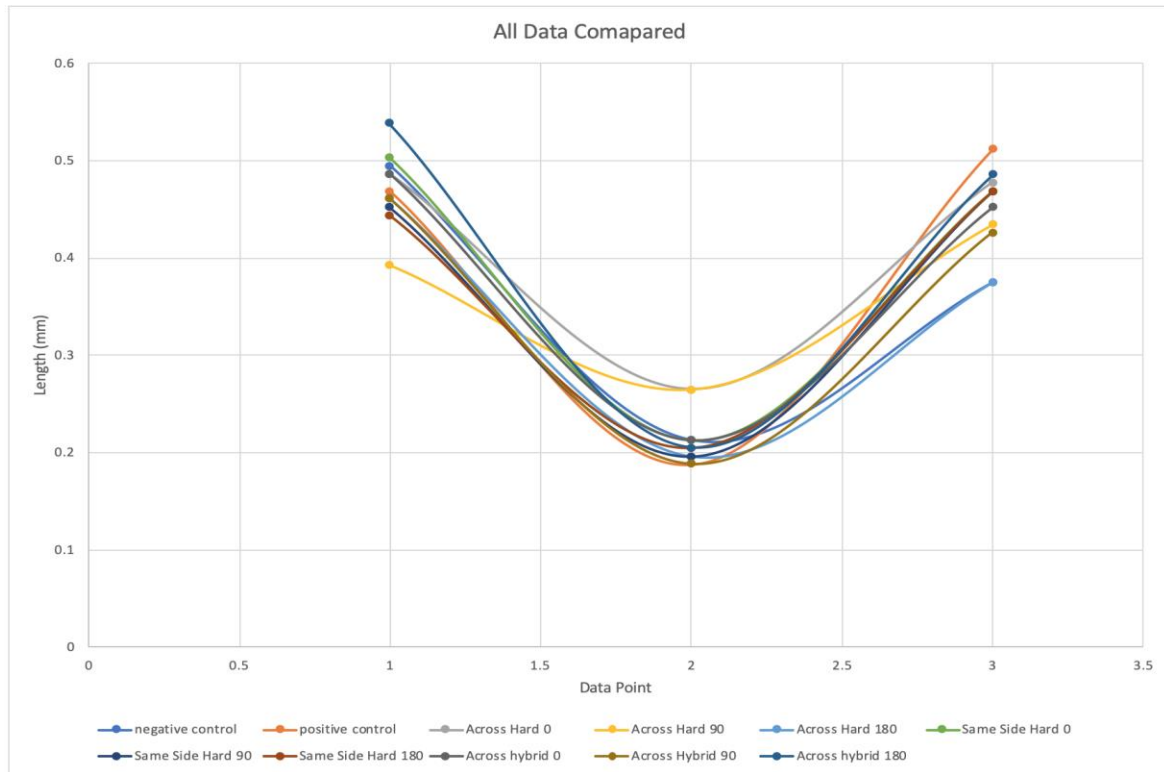

Figure 30: Comparison of the CT scans

Based on the data collected, the Across Hard 0 and Across Hard 90 configurations seemed to lift the patella more than the other configurations. There was little lift in the patella in these scans compared to the positive and negative control. Since there was not a significant lift in the patella the tests are inconclusive. The team sees the need to reproduce this test to show better results.

5.5. Kinematic Motion Tracking

Using the kinematic motion tracking equipment and software (Polhemus G⁴ Motion Tracker), the raw coordinate data from each trial was exported to a .csv file. The .csv files each ranged from 750 to 1000 frames, and each frame consisted of three cartesian coordinates for each of the three sensors. The value output for each cartesian coordinate provided decimals up until a thousandth of a millimeter. The matrix of the configurations that were tested can be found in Appendix III.

Variation existed between trials due to the various potential sources of error, the most egregious being the shift of the goat leg within the brace and within the setup. With the goat leg shifting and rotating in place, it would no longer be easy to measure the path length of the trials versus the controls in any comparable manner. Thus, we decided to attempt to measure the difference in a different way. After looking through many different mathematical options we decided on a geometrical approach.

By taking the difference between cartesian points, the team was able to calculate the vector magnitude for each line segment between the sensors. Segment “*a*” was the length between sensor 3 and sensor 1, segment “*b*” was the length between sensor 2 and sensor 3, and segment “*c*” was the length between sensor 2 and sensor 1. Sensor 1 was located at the tibia, sensor 2 was located at the patella, and sensor 3 was located at the femur.

The angle bisector theorem is able to produce the length of the angle bisector *d* given the length of segments *a*, *b*, and *c*. This theorem is detailed in Figure 31.

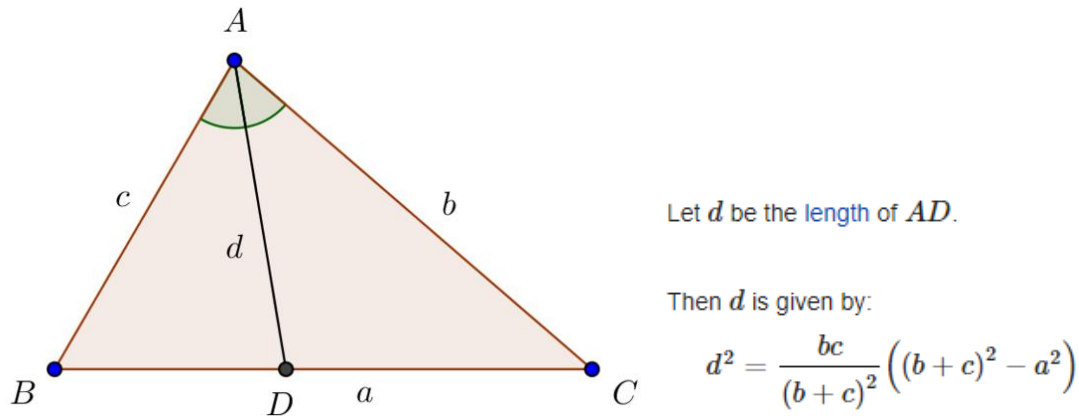

Figure 31: Angle Bisector Theorem where A is on the patella, B is on the tibia and C is on the femur and of which all are along the sagittal plane of the leg

The angle bisector was an important measurement because of the “direction” it had. We could use the fact that the angle bisector would always measure in the normal direction of the intersection at point A to our advantage. From the raw data we were able to calculate the line segment lengths and record the angle A. Point B corresponded to the tibial sensor, A to the patellar sensor, and C to the femoral sensor. Angle A then was representative of the flexion angle. Using these inputs, we could hope to isolate the patellar lift through taking the difference in bisector length. This is drawn out in Figure 32.

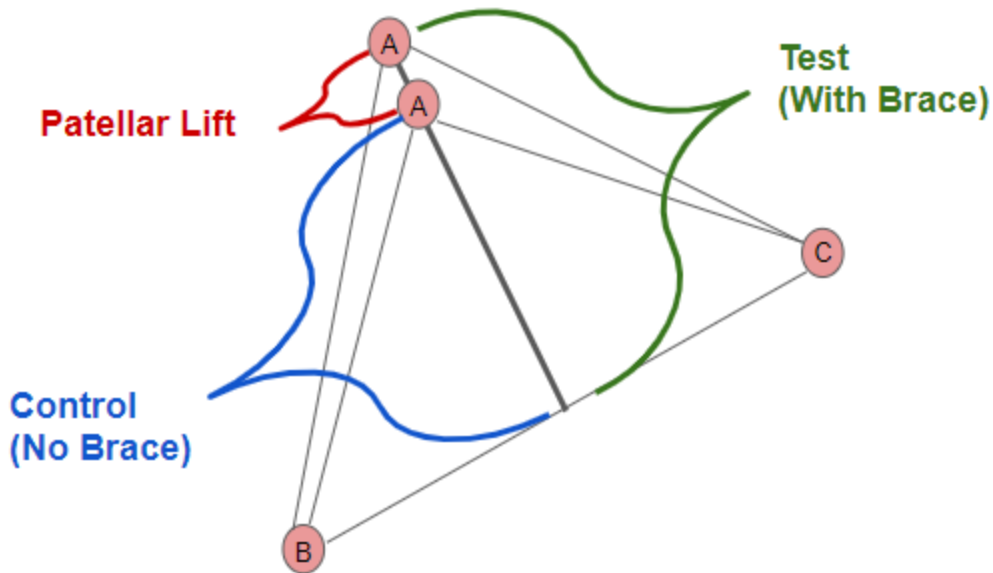

Figure 32: Patellar Lift

However, we soon discovered that this method came with constraints which must be considered. The bisector length did not remain constant during flexion. With the length of line segments b and c remaining constant due to the sensors being drilled into bone, we could model our situation as an isosceles triangle with a changing angle. Upon simple analysis it is clear to see that change in angle has a significant effect on the length of the bisector, as is shown in Figure 33.

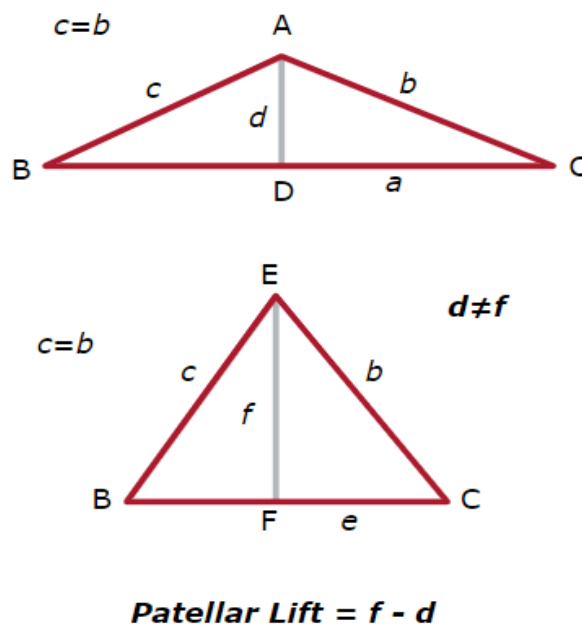

Figure 33: Relationship between angle and angle bisector

To account for this difference, it was imperative to compare the bisectors at the same flexion angle. Otherwise, there would be significant misrepresentations in the results.

The next step was to create a graph of the bisectors while taking account of the flexion angle to see how they were related. One small change that was made before creating the graph was to subtract the flexion angle from 180 degrees. This was to make the measurement consistent with the standard measurement of knee flexion shown in the Figure 34 below.

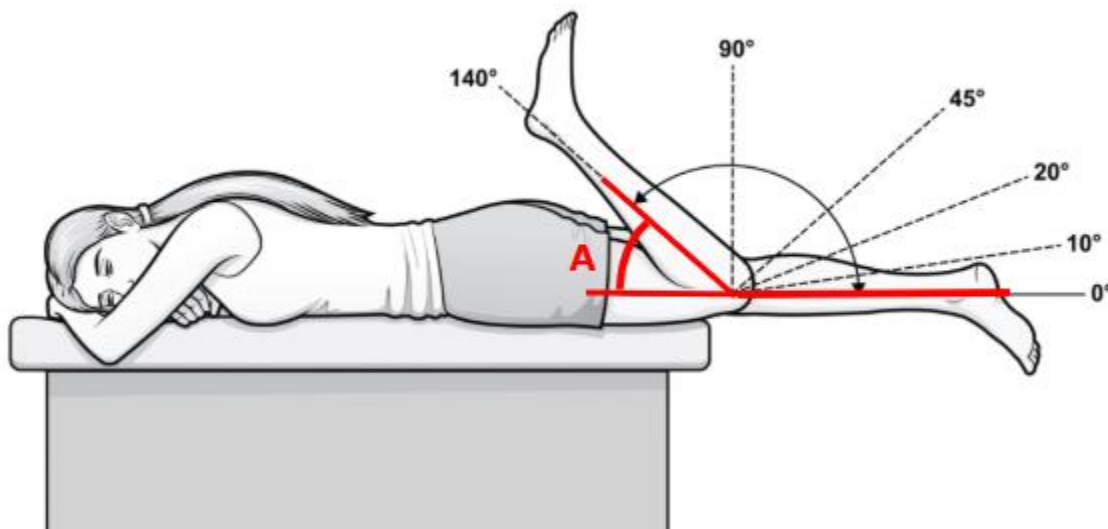

Figure 34: Flexion Angle Standard

With this change made it was possible to graph all of the data.

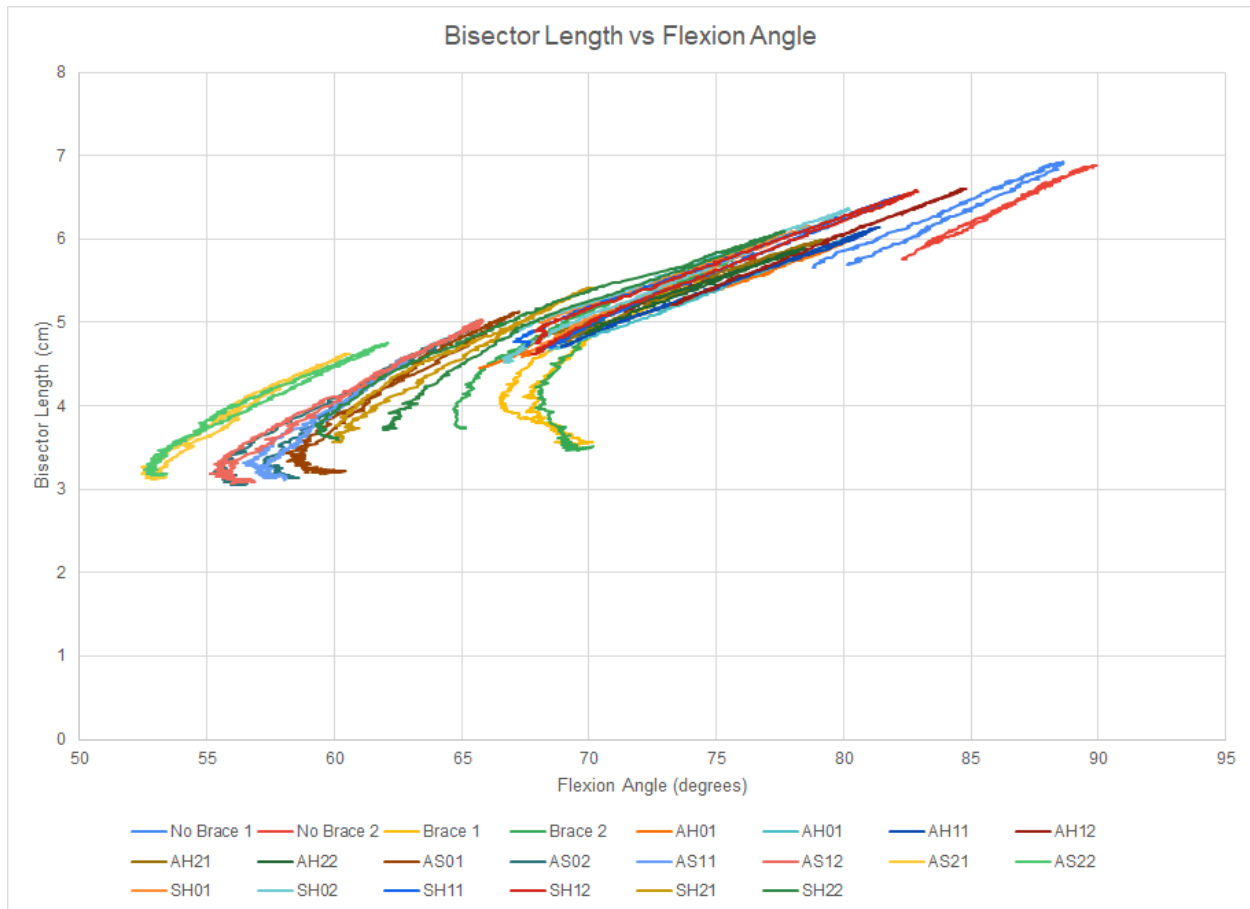

Figure 35: Bisector Length vs Flexion Angle

As seen in Figure 35, all the different bisector lengths are shown with the associated flexion angle of the knee. There are often two values of the bisector shown for each flexion angle (usually very close to each other). This is due to the fact that the test method flexed the knee, held it for three seconds at max flexion, and then extended it back to the original position.

On this graph the ideal comparison would be the bisector length at the max flexion angle. However, it is immediately evident that the max flexion angles do not often line up. In fact, in some cases the ranges of the data do not share any common flexion angles at all. The different setups between trials seem to have introduced different ranges of flexion as the leg shifted within the brace, and the padding which was added was moved around. However, the graph also showed the strong linear relationship between the bisector length and flexion angle. Depending on the strength of these relationships, it would be possible to make comparisons.

Looking at Figure 35, the linear relationship of the data points for each configuration seems very strong, especially near the max flexion end of the data set. In some configurations there seems to be a curved deviation at the ends which is possibly due to the leg shifting within the brace when it is closer to max flexion. This likely could have occurred due to the tension that the quadricep muscle was under and the brace not fitting the goat leg appropriately due to the smaller than average size of the leg used. These factors combined could have allowed for unwanted movement of the undersized goat leg within the brace. However, it is possible to just remove these data points when looking for the linear relationship. This is because we are trying to compare the bisectors at the maximum flexion values. In Figure 35, the linear relationship around the max flexion values are all very strong.

The next step in analyzing the data consisted of calculating the best fit line for the control data sets to find the linear relationships and R^2 values. These are listed in Table 10 below.

Table 10: Linear Relationship Between Bisector Length and Flexion Angle

No Brace 1	$y = -0.1334x + 19.110$	$R^2 = 0.9882$
No Brace 2	$y = -0.1499x + 20.427$	$R^2 = 0.9963$
Brace 1	$y = -0.1404x + 20.385$	$R^2 = 0.9503$
Brace 2	$y = -0.1327x + 19.672$	$R^2 = 0.9911$

All the relationships have a R^2 value of 0.95 or higher which demonstrates the strong relationship. The relationships then were able to be used to compare the bisector lengths at the same flexion value. This was done by plugging in the max flexion value of the trials into the equations and comparing the subsequent bisector length with the trial's bisector length. Figure 36 shows the average between the two trials performed with each brace configuration subtracted from both the average of the two trials performed for the positive control and the negative control. Since the controls involved no external forces on the goat leg, the differences made clear the success of each brace configuration and ratchet activation level with respect to one another.

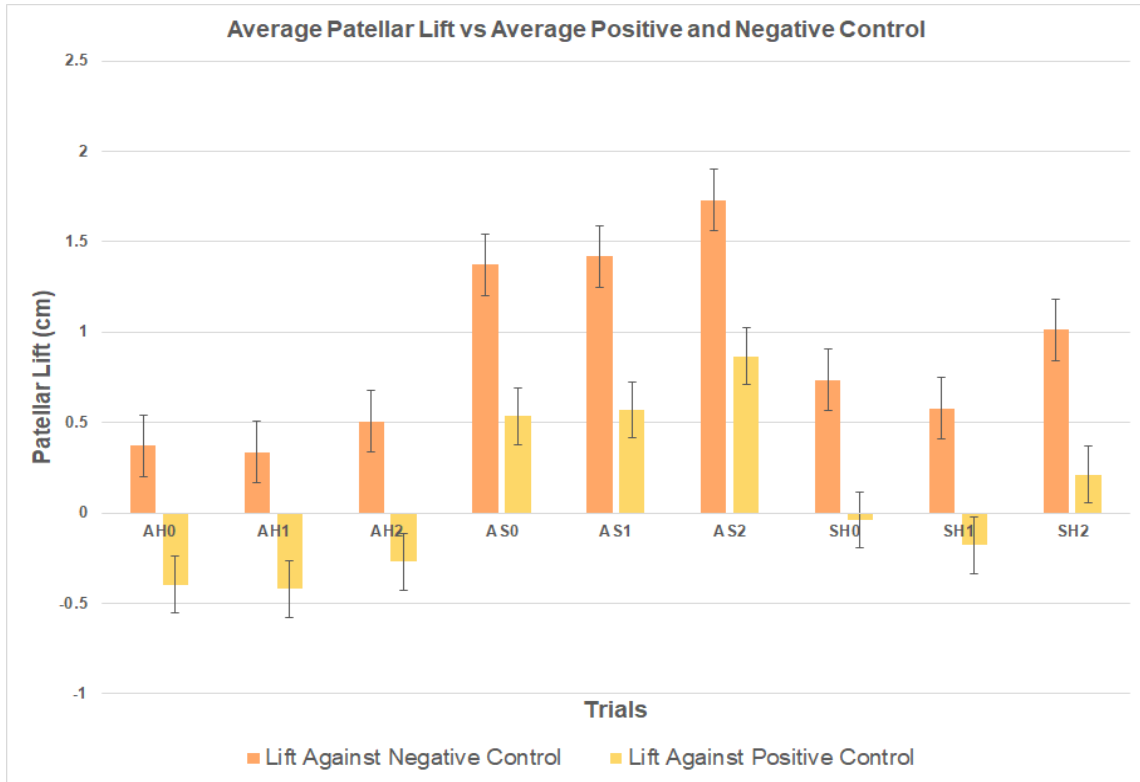

Figure 36: Average Patellar lift vs Average Positive and Negative Control. Going from left to right the x axis labels are as followed: Across Hard configuration 0, Across Hard configuration 1, Across Hard configuration 2, Across Soft configuration 0, Across Soft configuration 1, Across Soft configuration 2, Same Side Hard configuration 0, Same Side Hard configuration 1, Same Side Hard configuration 2

Based on these results, the team was able to conclude that the brace configuration that had the greatest patellar lift was the across, soft orientation with 180 degrees set on the ratchet. Based on the results, the patella was displaced by ~1cm, which is an extremely reasonable value. These results indicate that this brace holds promise.

5.6. FujiFilm

Test Method 08 was attempted and halted part of the way through. There are many reasons for this, but they all aggregate into the test method working better in theory than in practice. The team completed the set up as shown in Figure 37. However, the resulting cut outs of Fujifilm were inconclusive. As seen in Figure 38, the results were sporadic, and it was difficult to isolate the effect on the film as being created solely due to the patella.



Figure 37: Fujifilm Set-up

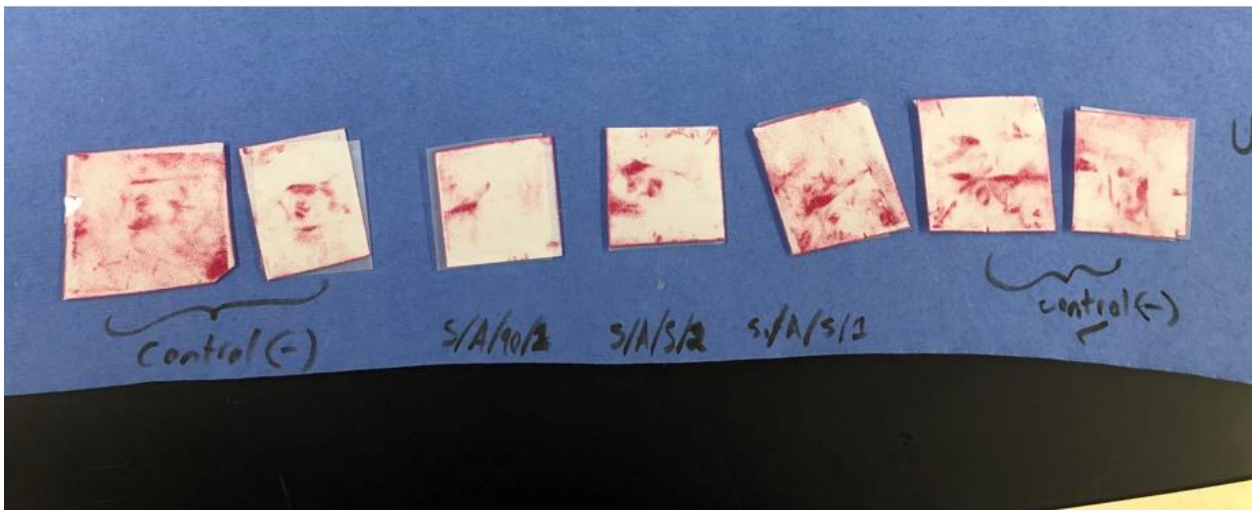

Figure 38: Fujifilm Results

Testing was halted for multiple reasons. First, the leg had been used for two tests before this one was started, as such the leg was worn and partially damaged. Additionally, for this test the leg was stiff from being in the refrigerator for 5 days. Lastly, cutting into the side of the patella compartment in order to insert the Fuji Film prevented the joint from normal, expected, motion. After initial attempted trials, the test was ended as the leg was not exhibiting properties necessary to collect significant data.

Overall, however, this method should be repeated in the future with a better-quality goat leg, as the data collected from this test method would still be valuable to understanding the efficacy of the brace.

5.7.C-Clamp Test

C-clamp selection was designed to get human feedback on their preference of clamp type. This test was run in conjunction with human testing. There were two test subjects for this test method, each subject wore the brace with the hard c-clamps then the soft c-clamps. Hybrid clamps were not tested as they were not available at the time of testing. The user secured the brace to their leg at their desired setting and performed a variety of actions including walking, walking upstairs, walking downstairs, sitting down and standing up. Afterwards, the subjects were asked a series of questions about the functionality, comfort, and overall opinion on preference of the brace. Below in Table 11 are the summarized pros and cons of the tests. Full test results can be found in Appendix IV.

Table 11: Summary of C-clamp Selection

Hard Clamp	Soft Clamp
<p>Pros:</p> <ul style="list-style-type: none"> ● Wedged well ● Felt firm <p>Cons:</p> <ul style="list-style-type: none"> ● Did not stay engaged through full flexion of leg 	<p>Pros:</p> <ul style="list-style-type: none"> ● Stayed in place ● Flexed with the flexion of the leg <p>Cons:</p> <ul style="list-style-type: none"> ● Less wedge

Both test subjects agreed that the hard clamp properly wedged around the knee well but failed to stay engaged after the knee straightened from being bent. While both test subjects agreed that the soft clamp stayed in place and flexed with the knee unlike the hard clamp, they still preferred the wedging ability of the hard clamps over the soft clamps. Overall, the subjects both wished to see a clamp that could wedge like the hard clamp but was flexible so as to stay engaged during full range of motion.

5.8. General Systems Testing

General Systems testing served to quantify the relationship between the rotation of the ratchet and the force exerted by the wire. The team conducted this test with the limited supplies available during D-term due to COVID-19. For this test, a 50lbs force gage was secured to a stationary pole and to the hook of one of the wires on the brace at the side of the knee joint. This test was conducted while the brace was worn by a user. To ensure all readings accounted only for the forces exerted by the wire, all other degrees of freedom were constrained. The brace was immobilized such that it could not rotate about the leg or bend at the hinges at the knee. Additionally, to control for the angle of measurement of the force to be perpendicular to the wire, the leg was aligned with straight markings on the floor under the stool, which were measured to be perpendicular to the pole. Below in Figure 39 is the full set up.



Figure 39: General System Test Setup

The test method consisted of 8 trials, starting at a force reading of 0lbs and each trial increasing by 90 degree turn of the ratchet. The data obtained from the 8 trials are graphed below in Figure 40.

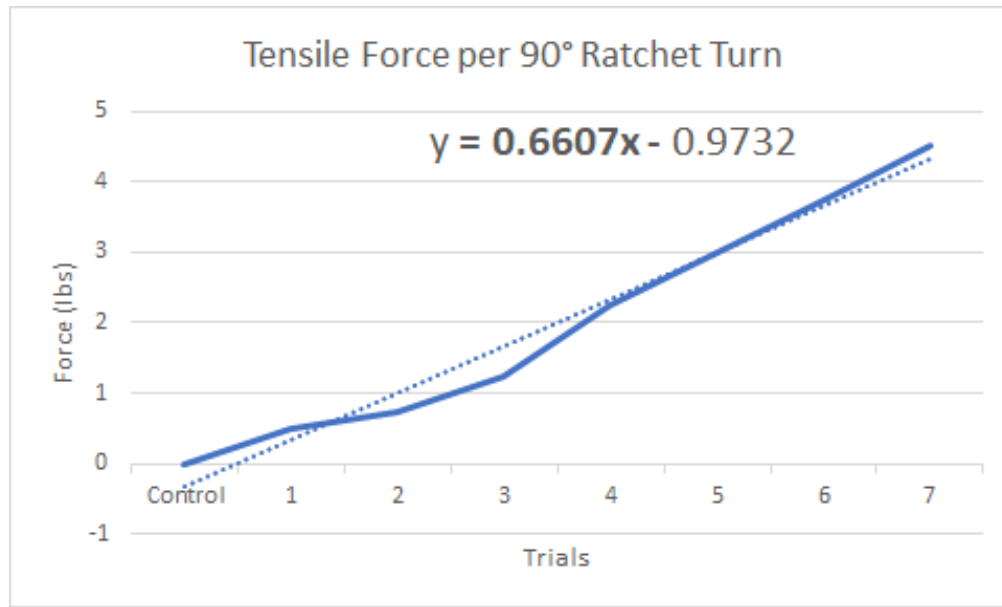

Figure 40: Force Per 90 Deg Ratchet Turn

From this line graph the best fit linear equation shows that on average the force increases by 0.66lbs per 90-degree ratchet turn.

5.9. Human Test

This test method focused on checking for skin abrasion from wearing the brace. Two test subjects wore the brace for 5 hours while performing their normal daily tasks and then checked and reported any skin irritation or marks caused by the brace. Below, Figure 41 shows the effect of the brace on the leg at the end of testing.



Figure 41: Picture of Subject Leg after Test

At the end of the test both subjects reported the wire digging into and leaving indents in the skin. But both subjects reported no other signs of abrasion from use of the brace for the test. A secondary observation from the test was reported that the subjects needed to readjust the brace frequently to stop the brace from falling down their leg. The subjects suggested utilizing more contact area between the skin and the brace, such as a sleeve or more straps, to help hold the brace in place.

5.10. Open Sim

The purpose of this test method was to serve as a conceptual check of our design validity. For this, the test method aimed to apply forces to an open source anatomically correct knee model found at OpenKnee in a finite element analysis software. The model produced from OpenKnee was created by a group of collaborating researchers who converted scanned CT images of knees into a single 3D model. Unfortunately, the 3D model meant for finite element analysis software does not include the patella and the tendons attached to it even though the rest of the knee is accurately modeled for the software. As such the team could not complete this test method. The team looks forward to the release of the newest model update which the team hopes will include an accurate incorporation of the patella and tendons.

5.11. Fatigue

One of the goals for the brace was to last one year of normal use. This test method was designed to simulate, on average, one year's worth of steps. The goal was to test if the brace fails before one year's worth of use. Since this test method was meant to test durability, this method was planned to be performed last, on the most finalized version of the prototype. However, due to COVID-19, the team was unable to pursue a more finalized version of the prototype using traditional manufacturing processes. Since the current prototype used 3D printed parts, this method was postponed until a later prototype was built using materials that would be for commercial use of the brace.

6. Discussion

The team was able to reach many conclusions based on the outcomes of the tests that were conducted. The first major conclusion that the team was able to make was that the brace was able to lift the patella during flexion. This is based on the data collected from the kinematic tracking test method. The best configuration was the across, soft orientation. In this configuration, the patella of the goat leg was lifted by approximately 1 cm.

The second conclusion that the team was able to draw was that the brace needs to be adjusted to meet the needs from human feedback. During the human feedback test, the wire came into direct contact with the skin. This caused an imprint of the wire on the skin and added pressure. Additionally, the human test showed that the brace slipped down the leg when walking. The team determined that there was a need for additional straps that would better hold the brace to the leg.

The final conclusion that the team was able to make was that there is a need for more testing. The team would like to complete more human testing to understand how to optimize the brace. This is further discussed in the Conclusion and Future Steps section of this paper.

7. Conclusion and Future Steps

The team sees the need for more work to be done on the device. Due to the shortening of the school year because of COVID-19, the team was unable to make some of the changes to the device that resulted from testing.

The team received feedback from human subject testing that would greatly enhance the brace. During human feedback testing, the subjects reported that the hard clamp wedged better, but the soft clamp moved more in line with normal gait. The team hopes to develop a hybrid clamp that is made out of a stiff rubber material that will be able to wedge as well as move with the joint. Additionally, the subjects reported that the brace slipped as it was worn. One adjustment that the team would like to make in the future is adding straps that would better secure it to the leg. The final adjustment the team would want to make based on human feedback is adding a layer of neoprene between the skin and the wires to reduce the contact and imprinting of the wires on the skin.

The team would like to complete a non-significant risk (NSR) early feasibility study (EFS). This study would be done with 12-15 participants with the goal of altering the brace using their feedback. This would be an iterative process that would help develop the brace. This would allow the brace to be as effective as possible.

Once the brace is optimized to have the best results, the team wants to create and optimize a manufacturing process as well. The team would like to work with a manufacturer to develop a subtractive or formative process to strengthen the brace components. Once the team has a developed process, we want to work with a distributor to sell the product. The team is also looking to work with an established bracing company to better market and sell the developed brace.

The team was able to submit their project to a few competitions. The first competition was the national Schulze Entrepreneurship Challenge. The team was named a finalist and given valuable feedback for the team. The team also plans on submitting to the Debut competition through Venturewell. This will help the team establish a company and further their goals. The team was also named the winner of WPI's Provost MQP Award in Biomedical Engineering.

8. References

- [1] Hamilton, W.J. (1976). Textbook of human anatomy, 2nd Ed., MacMillan (London).
- [2] Mansfield, P.J., and Neumann, A.D. (2018). Essentials of Kinesiology for the Physical Therapist Assistant, 3rd Ed. Elsevier.
- [3] Escamilla, R.F.1., Zheng, N., MacLeod, T.D., Edwards, W.B., Hreljac, A., Fleisig, G.S., Wilk, K.E., Moorman, C.T 3rd, Imamura, R. (2008). *Clin Biomech* (Bristol, Avon). 23(8):1026-1037.
- [4] Abulhasan, J.F. and Grey, M.J. (2017). Anatomy and Physiology of Knee Stability. *J. Funct. Morphol. Kinesiol.* 2 (34). <https://doi.org/10.3390/jfmk2040034>
- [5] M. E. Samuels, S. Regnault, and J. R. Hutchinson, "Evolution of the patellar sesamoid bone in mammals," *PeerJ*, 21-Mar-2017. doi: 10.7717/peerj.3103
- [6] Loudon, J.K. (2016). Biomechanics and pathomechanics of the patellofemoral joint, *Int J Sports Phys Ther.* 11(6): 820–830.
- [7] "Sandy's Story: Building Strength, Restoring Range of Motion and Getting Back to Life! - OSMS - Orthopedic and Rheumatology Services in Wisconsin," *OSMS*, 20-Nov-2018. [Online]. Available: <https://osmsgb.com/ortho/sandys-story-building-strength-restoring-range-of-motion-and-getting-back-to-life/>.
- [8] Zhang, G., Young, B.B., Ezura, Y., Favata, M., Soslowsky ,L.J., Chakravarti. S., Birk. D.E. (2005). Development of tendon structure and function: regulation of collagen fibrillogenesis. *J Musculoskelet Neuronal Interact.* 5(1):5-21.
- [9] "Patellar Tendonitis (Jumper's Knee)," *Patellar Tendonitis (Jumper's Knee) | Johns Hopkins Medicine*. [Online]. Available: <https://www.hopkinsmedicine.org/health/conditions-and-diseases/patellar-tendonitis-jumpers-knee>.
- [10] "Knee Ligament Injuries: Causes, Symptoms, Treatment & Prevention," *pt Health*. [Online]. Available: <https://www.pthealth.ca/conditions/sprains/knee-ligament-injuries/>.
- [11] R. Wilkerson, "Knee Arthroscopy - OrthoInfo - AAOS," *OrthoInfo*, Sep-2016. [Online]. Available: <https://orthoinfo.aaos.org/en/treatment/knee-arthroscopy/>.
- [12] "'Q' Angle," *Physiopedia*. [Online]. Available: https://www.physio-pedia.com/'Q'_Angle.
- [13] Huberti, H.H., and Hayes, W.C. (1984). Patellofemoral contact pressures. The influence of q-angle and tendofemoral contact. *J Bone Joint Surg Am.* 66(5):715-724.

- [14] Sherman, S.L., Raines, B.T., Burch, M.B., Ray, T., Stein, B.E.S. (2019). Patellofemoral Imaging and Analysis. *Operative Techniques in Sports Medicine*, 27(4): 150684.
- [15] C. Miller, “Patellar Subluxation (Partially Dislocated Kneecap),” BraceAbility, 21-May-2016. Available: <https://www.braceability.com/blogs/info/patellar-subluxation>
- [16] Johnson, D.S., and Turner, P.G. (2019). Replacement for patellofemoral arthritis. *Knee*. 26(6):1166-1170.
- [17] Adams, A.J., Kazarian, G.S., Lonner, J.H. (2017). Preoperative Patellofemoral Chondromalacia is Not a Contraindication for Fixed-Bearing Medial Unicompartmental Knee Arthroplasty. *J Arthroplasty*. 32(6):1786-1791.
- [18] Patel, D., Hogan, K.A., Schutte, H.D. (2019) “Patellofemoral Arthritis,” Background, Anatomy, Pathophysiology. <https://emedicine.medscape.com/article/1933589-overview>
- [19] Cuthbert, R., Tibrewal, S., Tibrewal, S.B. (2018). Patellofemoral arthroplasty: Current concepts. *J Clin Orthop Trauma*. 9(1): 24–28.
- [20] Day, R.O., and Graham, G.G. (2013). Non-steroidal anti-inflammatory drugs (NSAIDs). *BMJ*. 346:f3195.
- [21] Schumacher, H.R., and Chen, L.X. (2005). Injectable corticosteroids in treatment of arthritis of the knee. *Am J Med*. 118(11):1208-1214.
- [22] Grelsamer, R.P., Dejour, D., Gould, J. (2008). The pathophysiology of patellofemoral arthritis. *Orthop Clin North Am*. 39(3):269-274.
- [23] Malek, M.M., and Mangine, R.E. (1981). Patellofemoral pain syndromes: a comprehensive and conservative approach. *J Orthop Sports Phys Ther*. 2(3):108-116.
- [24] Summit Medical Group (2014)
https://www.summitmedicalgroup.com/library/pediatric_health/sma_patellofemoral_painsyndrome_exercises/.
- [25] Derasari, A., Brindle, T.J., Alter, K.E., Sheehan, F.T. (2010). McConnell taping shifts the patella inferiorly in patients with patellofemoral pain: a dynamic magnetic resonance imaging study. *Phys Ther*. 90(3):411-419.
- [26] Evaniew, N., Simunovic, N., Karlsson, J. (2014). Cochrane in CORR®: Viscosupplementation for the Treatment of Osteoarthritis of the Knee. *Clin Orthop Relat Res*. 472(7): 2028–2034.
- [27] Medical Advisory Secretariat. (2005). Total knee replacement: an evidence-based analysis. *Ont Health Technol Assess Ser*. 5(9):1-51.

- [28] What causes OA? How does a knee brace help? - Valgus / Varus. Orthomen.
<https://www.orthomen.com/blogs/knee-braces/medial-valgus-unloader-brace-for-osteoarthritis>
- [29] Toda, Y., Segal, N., Kato, A., Yamamoto, S., Irie, M. (2001). Effect of a novel insole on the subtalar joint of patients with medial compartment osteoarthritis of the knee. *The Journal of Rheumatology*. 28(12) 2705-2710.
- [30] Stefancin, J.J., and Parker, R.D. (2007). First-time traumatic patellar dislocation: a systematic review. *Clin Orthop Relat Res*. 455:93-101.
- [31] Campbell, K.A., Erickson, B.J., Saltzman, B.M., Mascarenhas, R., Bach, B.R Jr., Cole, B.J., Verma, N.N. (2015). Is Local Viscosupplementation Injection Clinically Superior to Other Therapies in the Treatment of Osteoarthritis of the Knee: A Systematic Review of Overlapping Meta-analyses. *Arthroscopy*. 31(10):2036-2045.e14.

Appendices

I. Interviews

a. Dr Mieslin

- Do you have access to the forces applied to the patella by connective tissue and skeletal muscle? We need a resultant force for our prototype's technical design.
 - (If he does not have that info) Can you identify for us the muscles, tendons, ligaments etc. involved in pulling the patella?
 - **The forces are pretty basic.**
 - **Victor Franco wrote a biomechanics book**
 - **Full extension there are minimal forces**
 - **From 0 deg to 20 deg there should be minimal forces.**
 - **20-30 deg of flexion there is more pain**
 - **Why is 55-60 deg maximum force?**
 - **High flexion the force is 3x body weight**
- Do you have any sort of visual model of the patella that flexes in motion?
 - **He can get us a basic knee model**
 - **Working with a cadaver is hard but creating a 3d model might be easier to use**
- What force would you like to see a reduction in the knee?
- Clarify our current User Needs
 - **Cover all the demographic with the disease**
- Are you able to get in contact with someone with PFA?
 - Would we have to fill out any sort of paperwork in order to interview patients?
 - **Pain centers around the kneecap**
 - **Primary focus anterior knee pain**
- What was your inspiration for this project?
- Pitch our Tentative Design ideas
- Give breakdown of our schedule (In months not ABCD term)
 - Working on Background
 - Interviews
 - Define Knee biomechanics
 - Work on Design
 - Pick Design
 - Prototype
 - Testing by December
- **Specific demographic**
 - **Women in their 20s and 30s have hypermobility issues**
 - **20+**
 - **Patellofemoral pain**
 - **He sees demographic across the board**
 - **Athletic world and elderly**
- **What do you recommend now?**
 - **KT tape**
 - **Injections**

- Rarely cortisone
 - Surgical procedure
 - Brace would be the initial step (once developed)
- **Q angle**
 - Potential risk factor
- **There are tables with the forces with different common activities**
- **Knee contact area is crucial**
 - Surface contact area

b. Mike DeSavage interview

Master's thesis in college was on shoulder braces

Do a lot of bracing in athletics

If you do not have a space in the back of the knee the leg will not bend

Don-joy is a bracing company -- stopped making their most successful brace

Patella usually goes laterally

This is because the lateral quadricep is bigger than the medial side

Most common injury is the lateral dislocation of the kneecap

- What treatments have you used? Taping?
 - **McConal tape job -- can look this up**
 - **KT tape is more of a sensory thing whereas the McConal tape is more of a stabilizer**
 - **Might have some success using KT tape and pulling that up**
 - **Using Velcro to pull up the KT tape**
 - Have any treatments been more successful than others?
 - What physical therapy do you recommend?
 - What has been your experience with KT tape?
 - Successes with it?
 - Can it move/realign more than muscle tissue?
- How do you measure a patient's pain (Ex. rate form 1-10)?
 - **Mostly just pain management but not full healing, chronic injury, mostly evaluates by watching them wince when playing with the knee**
- What population do you see this the most in? (Ex. Do you see this more in athletes? Specific Sport? Female Athletes?)
 - **Runners-- one of the teams was jogging over the summer and then the team started doing side to side maneuvers and the knee was not trained to do this and it caused a lot of injury**
- How do you wish PFA could be treated? If money/technology was not an option? - If money was not an issue, how would you envision treating PFA
 - **Somewhere to add a number system to adjust the brace,**
- Where is there still a gap in user need?
 - With regards to bracing?
- Do you know of people that have had surgery to treat PFA?
 - **Had someone have 6 surgeries -- this person had so much damage on the bone that she needed surgery**
- Ask him about the biomechanics of the knee? Do you know how we could go about finding this?
- Is there swelling that occurs with PFA?
 - **There can be a lot of swelling with this injury**
 - **Ice calms the swelling**
- Have you had any experience with lubrication shots (hyaluronic acid shots, cortisone shots?)
 - **Doctors tend to make this type of recommendation, not common**
- Are there any resources that you can point us to?
 - **Reach out directly to companies like DonJoy**

- They might be open to being involved
- They are money driven though
- Work closely with Worcester PT and Greendale PT
 - The old head athletic trainer works at Worcester PT

Ensure that the materials are lighter so to not impact the sports (running times etc.)

Tough skin makes skin tacky

Typical questions asked is does it hurt to walk upstairs? Downstairs?

Look at NCAA regulations

c. Dr. Butler

Butler Notes

- Ansys
- Bumper idea
- Practice point
- Enough sensors, fine sensor, (need more cameras)
 - Quantification would be motion analysis
 - Muscle activation within Practice Points
 - Understand forces
 - How joint is moving at different points of flexion
- Look into different sensors, small
 - Motion in different directions
- Changes in movements of patella with/without brace

Or muscle tension - to

Look into models for this force means this contact force/pressure

Finding movement due to action occurring

Moment at joint, all muscles working together

More this muscle * moment is + force in this muscle *moment arm

Estimate based on anatomy what muscles are activating (or with sensors)

Distance of application

Check against actions - most vulnerable to pain in these degrees of motion

Compare with forces in terms of BW

Abacus, Ansys,

Potential connect with a senior research scientist at university of Iowa

Professor Troy - finite element analysis

- d. Dr. Troy
- Testing considerations:
 - Biplane fluoroscopy of patellar tendon
 - Pressure sensors
 - Fujifilm wrapped in Mylar
 - Die can burst at certain pressures
 - Film cannot become wet
 - Will need to determine various levels of calibration
 - Tech Scan
 - Change in pressure distributed over flexion
 - ~\$80-100
 - Limited localization
 - Electromagnetic tracking by drilling into the femur, patella and tibia
 - Grab patella, fix position of femur and patella. Obtain centroid, attribute to eigenvalue and then use that to determine patella displacement
 - Use pin holes
 - Voxyl size
 - Open SIM Knee Software
 - FEA software for knee
 - Also called SIM TK
 - CT Scanner
 - 15cm² length
 - Should fit brace dimensions
 - Probably will not be able to flex patella in CT scanner

e. WPI Community Member 1

Notes:

- Blew both ACLS
 - Wears two braces on both
 - Playing basketball
 - Surgeon
 - One cadaver
 - One of his own
- He has gone back to basketball
 - That is why he got the braces
- They cut into the back of his knee
 - Has 2 so kind of awkward
- The knee braces were more preventative
- Both knees hurt
- Hinges
 - 6 or 8 different straps
 - Curved
 - Custom fit
- Went to orthopedic
 - MRI, X-ray
 - Want to play again
 - Get this brace
 - Custom - 1000
- His brace hurts
 - Does not use it because it bites into his knee
 - Even with a sock
- Pain
- One bright orange
- One bright green
- Not hiding it
- Wife when skiing
 - Has to conceal because of the cold
 - Not that comfortable
- Physical Therapy is amazing
- Electrical stimulation helped to jump start the leg flexion
 - He thought the muscle was gone
 - But he helped find the muscles with e-stim
 - The change routines each week
 - Non intuitive
- Cheaper sure good for sports
 - But they good the option custom
 - Presumably better
 - Willing to pay a lot for health
 - Duct tape on car

- f. WPI Community Member 2
- How long have you had knee pain?
 - Probably about 6 months. He believes it is because he has been running for 50 years. 55,000 miles ever, 1,400 miles per year. 26 miles per week. 3-4 runs per week. He has done 15 marathons. Overstrained and developed Achilles tendonitis. Trained on an elliptical to rehabilitate. Felt his Achilles hurt during the first hour of his most recent marathon. He has done physical therapy, given inserts in his shoe. He took out the knee implant, and that brought up the knee pain. When running, he can feel it come back.
 - Have you been diagnosed with a particular condition?
 - Went to primary care. Gave a prescription for PT, referral for orthopod, but Aleve has been satisfactory. He does not like taking it, he would prefer not to solve this with drugs. Insurance covered the PT.
 - Is the pain localized in the knee joint or does it dissipate to other parts of your leg?
 - Hip and dissipates down.
 - How do you currently treat your pain?
 - What treatments have you tried? What were the pros and cons to those treatments?
 - Massage therapist and chiropractor. He went to PT in Worcester and did not think it worked. He had a cortisone shot in his Achilles, and that did not work. He is interested in using a small band knee brace, he does not want to wear anything larger.
 - How/Who recommended this treatment to you?
 - Podiatrist, they diagnosed the knee pain (starts with the hip, radiates down causing knee pain). He did not like to have to pay hundreds on the inserts. There are other informal
 - Why did you talk to that person?
 - Were they actually helpful?
 - Have you ever used a knee brace for this pain before?
 - What was the process you had to follow to get a knee brace? (if applicable)
 - When do you feel the greatest amount of pain?
 - Any particular actions? Time of the day?
 - What would you consider your activity level?
 - Workout / go for runs for how many hours/miles per week?
 - At what age did you come to notice that you had knee pain?
 - Was there something you were expecting us to ask that we did not?
 - Expected us to ask if he had used braces before. He has used a simple wrap before, but he did not see much improvement. Sometimes his knee would lock in wrestling, and a coach would have to pop it back.

g. WPI Community Member 3

Notes:

- The warmth helps to get the blood flowing
- Had runners' knee
 - Patellar Tendinitis
 - When he was at his highest activity level (120 miles a week)
- Iced it afterwards
- Knew a lot of people with pain on the side of the knee
- He has known a lot of people to give up running for this
 - Particularly women
 - Q angle again
- Only really rest has worked - braces have not worked for him or in his experience
 - Took a couple months of rest and came back slowly
 - 2-3 months November - February
- What was the PT and rest process like for you?
 - Straightforward referral
 - As long as you are insured - they push a lot of PT
 - Because they are a business, they try to keep you
- Doctors do not give out braces for these issues ~ unless you snap an ACL
 - Even the PT people are not going to send braces
 - Maybe the Patella support band
 - Did not help him
- Runners are crazy
 - People are looking for things to put on so that they can still exercise
- His issue is more overuse, so the tendons get overworked.
- Using bracing for *during* running
 - Not really using it for after
 - Except for when he had severe tendinitis
 - It took the pain away for when he was walking
 - The warmth and the support
- Braces could almost be negative as they are currently because they allow you to exercise when you maybe should not.
 - It takes the pain away and maybe exacerbates the issue.
- His wife had hand-based tendinitis
 - She ordered a brace on amazon
 - She showed to her doctor - he said that is what he would've gotten her but his would have just been more expensive.
- Runners, especially older
 - Some are osteoarthritis
 - Some are patellar tendonitis
 - All related to pain in some form
 - Maybe related to mechanics of their form
- He is worried about squats and quad stuff because of his age
 - He needs the muscle mass for the knee
 - He knows he needs to prep for the season to prevent injury
- They are all doing their PT exercises

- More likely to do them due to athlete
 - And age for injury prevention
- Squats are the toughest for the knees
- A lot of bikers refuse to shift gears (because of the knees)
- Basketball - ACL & MCL (same with Soccer)
- Swimming - Breaststroke
- He thinks there would still be value for a brace, even if it did not allow for exercise because it would relieve pain.

h. Umass Memorial Orthopedic Surgeon

- What is your position title?
 - How long have you been working in this position?
- How often do you treat patients with patellofemoral arthritis?
 - What population usually has PFA?
 - Over the age of 50, sometimes isolated PFA (more common in female patients-could be in the 30s/40s)
 - Do they have similar? Weight or runners? We see all the subsets, women mostly because of the q-angle which causes it to be knocked knee(can be predisposed to PFA, early kneecap intervention (preventative) can move the patellar tendon to reduce the q angle)
- 3. What treatment method do you currently use to help these patients?
 - Wide range of treatments, protein/plasma rich platelets (to regrow cartilage, not proven) knee replacement (usually partial) not a lot of data on the technique, he does not do partial, he only does full replacement, but some do medial or lateral compartment replacements
- At what point do you decide to do replacement?-surgery is only once everything else fails, so first pin meds and PT, then move to surgery if those do not work, arthroscopy to clean up the knee
- What is the biggest problem with trying to treat PFA?
 - Most patients either do not want to or cant (medicine), weight is more and more of a problem, a lack of good surgical options that are long lasting's- fixation, rest of knee wears out, patient understanding more and more patients are showing up with arthritis earlier in their life whereas replacement was originally reserved for 60+, lots of people want to stay active but the replacement cannot replace the knee you're born with, better than a bad knee
- Is bracing something you see in older populations? Some can use taping, sometime patella realigning surgeries, can do cartilage transplant (from your own knee), Genzyme can grow your cartilage to put back into you, microfracture-cartilage defects so drill small holes into the bone to grow scar tissue which is similar to cartilage (not normal cartilage, but better than nothing) also not a permanent solution
- Do you try to unload the knee?
 - Only if the weight is on one side or the other (like most unloader knee braces) there is a surgery where you can break the bone,
- Most alignment treatments are before the arthritis develops
- Is there a financial burden? Arthritis is up there because it is chronic, lost work, reduced productivity, arthritis is definitely a significant burden, no medicine to regrow arthritis, full knee replacements are better than the partial replacements
- Where is the pain coming from? Right under the kneecap
- Is there nothing on the market to lift on the patella? No, nothing, lifting it could potentially have biomechanics issues, usually the patella is shifted side to side or tilted
- 4. Is there a treatment method that you hope to see developed to treat PFA?
- 5. What treatments align with what stage of PFA?
- 6. How could treatments be made more effective?
 - Things that were longer lasting like cortisone shots but has a large time range for when it wears off, effectively and efficiently replacing the cartilage, anything with

hardware wears out, non-biological glues will wear out

- At what point do you move from cortisone shots to replacement?- its elective, comes down to quality of life, more a conversation between doctor and explaining the options available to them, everybody is different, so they choose different options
- 7. Was there something you were expecting us to ask that we did not?
 - no

- i. Retired Registered Nurse
- She is currently retired
 - She understands how things get approved for payment
 - Also understands how to work the connections between orthopedic surgeons and bracing companies
- She worked in and out of PT with people
- She has not had PFA herself
 - But her friends have had it (Skiing)
- She worked in Orthopedics for a long time (not in the past 25 years)
 - She does not work directly with the patients anymore
- She has mostly seen PFA in younger athletes
 - But she also believes older patients could be a demographic
 - One more group that is most likely to recommend a specific brace are physical therapists.
- There are unmet needs
 - Something that works
 - Something that is easy to use
- PFA is a long-term chronic thing
 - Athletes just want to play
 - Older generation just want pain relief
- The product that is right for them
- Many cases the brace is not covered by insurance
 - Patients want something that works and that is cost effective for them
- “Medicare is a 900-pound Gorilla”
 - If it gets approved by Medicare, there is a higher chance of it getting covered by other insurance plans
 - DonJoy has a full-time insurance person
 - They cover which products will be covered by insurance
 - They have good info on how to get products covered
- ACL Reconstruction failed after 20 years
 - DR recommended brace
 - Would delay needing another replacement
 - Allow to ski again
 - Insurance covered brace
- Had shoulder surgery
 - Got a brace with it
 - Have not received a bill for it - unsure if it covered by the procedure payment
- Best product that meets you needs and is affordable
 - But if it is not **comfortable** it is not meeting your needs - they will not wear it.
- Price point - If it is something we want to be covered by insurance
 - Big insurance companies have technical assessment committees which assess products and decide whether it is in their interests to cover it.
- If we can get through this process, then it would be paid for by insurance which is a huge positive.
 - Just increases the amount of people that would use the brace.
- Ron Hurska

- Does a lot with muscle and balance?
- Did some Patellofemoral stuff
 - Theory that it was caused by muscle imbalance~~
 - There could be a therapeutic competitor
- On his own ~ maybe through
- Postural Restoration institute website
- When a new product comes out in the market, there is a lag for when it is adopted
 - What accelerates that is efficacy
 - cannot be the same effectiveness, has to be better

j. Umass Memorial Sports Medicine Doctor

Notes:

- The most common diagnosis is knee arthritis
 - Mostly middle age
 - Not totally inactive
- Start with the least aggressive option
 - Then move up
 - Physical Therapy, pain management, braces etc.
- Never use a brace in isolation, typically pair with PT
 - Not a particular reason
- The compression generally helps arthritis
 - But PFA not so much, more irritates it
- The Patella bands are for Patellar tendinitis
- Diagnosis based on Patient answers, x-rays, and an exam
 - Leaning hard on x-rays for diagnosis
 - Weight bearing x-rays
 - Fairing signs, bone spurs, sclerosis (whiter than rest of the bone)
- Compartment vs entire joint?
 - Generally multiple compartments
- Most patella dislocations are lateral
 - Lateral trochlea is injured
 - The cartilage is banged off as it goes out or back in
- Patellar alignment
 - More likely to develop arthritis
- 98%
- Do not have to worry about the tendons being stretched or if we are shifting medially or laterally in burdening the other cartilage
- How to prove
 - Blind study shows PFA same population
 - With brace / without brace
- Uses rehab braces to recover from surgery
 - Functional bracing
 - Looking for price and convince
 - Based off of company – trusts them
 - Otherwise the compression braces are all so similar – there is not difference
- Most places like this (Umass) do not stock braces without hinges
- Best ways for us to advertise
 - Journal
 - Conferences
 - Publish where surgeons would see or other professionals
- It would really help to have proof of efficacy
- The braces they have, are compression braces with hinges (rigid not soft)
 - Not really for PFA
 - Go to Dicks, get a compression brace
 - Some helps and some it does not
 - One that squeezes the entire brace

- Compression helps with swelling
- Pain for PFA is it from of swelling or from bone?
 - Both
 - It is from swelling or flares
- PFA replacement is only when everything else does not work
 - First PT
 - Then cortisone injection
 - Then arthroscopy
 - Then knee replacements
- Replace the whole knee (most people)
- You can do partial (but generally not as effective)
- The goal of the patient
 - Pain relief
 - Function (depends on above)
 - Depends on individual
- If you improved pain
 - There would be value no matter how much
- Braces have very low risk
 - If you could reduce pain at any stage, there would be value
- Can go straight to human
 - Low risk
 - And do to issues with using animals, getting comparison efficacy and pain feedback
- Pain are usually visual analog scales (1-10)
 - Depends on certain actions
 - Like upstairs, downstairs, when you kneel
- Where is the inflammation occurring?
 - Some bone inflammation
 - The synovium (diffuse swelling)
 - Ice, medications, injections,
 - When it is irritated, it makes more fluid
 - The body hates stretch
- Most people are going to have patellofemoral tracking
 - So up is best
 - But also, up and medially would tackle most

k. WPI Athletic Trainers

- **What is your position in your physical therapy company?**
 - Hailey 4 YEARS ATHLETIC TRAINER, Rachel- 3 years.
 - **How long have you been working as a physical therapist?**
- **How often do you treat patients with patellofemoral arthritis?**
 - Not yet arthritis, but the syndrome is the start, when kneecap is not tracking correctly, every day, most common chronic injury, usually in both knees, special tests-is not ligament, is it PFS, apprehension, find where pain is, how do they stand, bowlegged? Arches? Observation is key, could give us the “standard operating” principles of athletic training, orthopedic test for PFS, has a full range of options for treatment based on what is causing the pain, knee alignment, higharched, hips placement,
 - **What population usually has PFA?**
- **How do you recommend that patients continue with their daily activities while dealing with PFA?**
 - Generic braces, j-strap patella, DonJoy true pull is the best that has ever existed on market, the spider brace- those suck, DonJoy and Breg, true pull was best because you could apply as much pressure as you wanted, the doctor’s office set the pressure “brace technician”/trainer, something that could be better about it? Irritation-skin irritation, Mike used it at Woo state, Hailey used it at Keen, biggest problem with most braces is that there is not enough room behind the knee to allow for movement, no preference between sleeve and strap its entirely personal preference, slipping is large issue, hold against the top of calf or be really high on the thigh, some like compression, most athletes try to avoid bracing and prefer tape, cost is a large factor since tape is cheaper, underlying reasons, usually only take 30 minutes to diagnose, there are brace fitters, SURGICARE-TALK TO THEM, rarely have patellofemoral braces in orthopedic offices
- **What treatment method do you currently use to help these patients?**
 - Ice and rest most often, strengthening VMO, hip muscle because they can push/pull the knee out of the way, KT tape, McConnell taping is gold standard, biggest thing is rehabbed to strengthen all muscles around the kneecap to help reposition it. You need to irritate it to help fix it, aka small lunge/squat to help.
 - **What do you like best about this method?**
 - **What do you like the least?**
- **Is there a treatment method that you hope to see developed to treat PFA?**
- **What treatments align with what stage of PFA?**
- **How could treatments be made more effective?**
 - Younger population or older get those braces, people are generally “satisfied” with the performance and pain relief of the brace, its either brace or tape, for the most part it tapes
- **What is the biggest issue with treating PFA?**
 - Exercises that bother it are also the ones that will help it, they need to basically stop, stop moving until pain free and then slowly build up the strength to help support the knee, sometimes injections, where is the arthritis? There are just so many variables and MRI are usually later in the treatment if things are not helping, first year 7 years ago, woman had 7 surgeries on it, they had joint glue, just change some activates

- Treatment plan is the hardest, because it takes time and you need to convince them to commit to it for some amount of time: they can be extremely variable for how long but mostly 6-8 weeks treatment plan
- **Was there something you were expecting us to ask that we did not?**
 - You could make the best brace in the world but if insurance will not cover it. Have to order from dealer basically instead of going through insurance
 - Research biomechanics of the knee, like how it moves, its usually just not the knee

1. Worcester PT

- **Is there a treatment method that you hope to see developed to treat PFA?**
 - Early education is idea
 - The earlier you get to a problem the better-- physical education -- learn about proper movement
 - You can see a lot of impact in this
 - PT only see people when it is a problem
- **What treatments align with what stage of PFA?**
 - Only major change is treating the inflammation and swelling-- do lower level activities -- address other impairments before

Women tend to have more PFA

Weakness of the VMO

There are weaker glute muscles

Knees come together

PFA happens when the patella moves medially and laterally

Causes that irritation and pain

PFA typically happens when someone is active is having knee pain – in younger people

Increase glute strengthening and improving form

There may be different restrictions that will impact the knee

Most patients come 2-3 times a week

Have at home activates that they do

Try to address impairments

Common supplemental treatment

j-braces

KT tape can be used

McConnell taping can be used

The taping will not have long term benefits

Compliance with the home program is essential to the success of the program

Mechanics are critical to making sure that people are doing it correctly

PFA should go away as long as you will fix your mechanics

Early onset pain – lots of patients – if treated and corrected there is chance of good recovery

Usually a knee replacement is not just PFA, usually more

If there is a knee replacement, there can be an artificial kneecap or the regular one

There is a lot of patients that have arthritis—it is the breaking down of the joint

There is a lot to people with arthritis

People are becoming more active

They see a lot because they are an orthopedic company

You see the younger patients with lateral tracking and older people with joint breakdown
The treatment is usually the same
Look at squats ROM and look at different deficits

People are lacking hip extension
Hard to flex glutes

Functional outcome score-- scale for the success of the program
There is a knee specific functional scale
KIOS ?
Objectify some
Strength training
Observation of the patella tracking

m. Greendale PT

- **What is your position in your physical therapy company?**
 - Rachel 5 years in outpatient
 - Nick 9 months -- just graduated
 - **How long have you been working as a physical therapist?**
- **How often do you treat patients with patellofemoral arthritis?**
 - knees are the middle tier problems
 - Knees are up there in treating
 - Patella dysfunction-- teenage girl and she grew 5 in in a year and the tracking problem
 - See this as a patellofemoral tracking problem
 - The function is not affected as much with the younger
 - Weak hips are the main aspect of it
 - Arthritis is more in older people
 - **What population usually has PFA?**
- **How do you recommend that patients continue with their daily activities while dealing with PFA?**
 - In the younger age it is a muscle thing in the hips
 - Weaker hips
 - Actual arthritis is a stiff joint
 - The young girl has a normal range of motion
 - There is a neurological component to this
 - They have difficulty controlling their body
 - Actual arthritis is trying to loosen the joint
- There is a lot of swelling and pressure on nerves
 - There is a true grind of the patella there can be bone spurs
- **What treatment method do you currently use to help these patients?**
 - Patients come in 2 times a week
 - Patients get a home program that they can work on their joints
 - Not everything at home-- some patients can do aquatic therapy
 - **What do you like best about this method?**
 - The methods work but they take a long time
 - It is hard to get this through to patients
 - Sometimes you get worse before you get better
 - Convincing them to come back and keep working on it
 - Sometimes there is too much degeneration and they might need a surgery-- it can sometimes be the only option
 - You can treat the symptoms but not fix it always
 - **What do you like the least?**
 - Giving them a few exercises to keep the joints moving
- **Is there a treatment method that you hope to see developed to treat PFA?**
 - Look into muscle firing and biofeedback -- ability to focus on specific muscles
- **What treatments align with what stage of PFA?**
- **How could treatments be made more effective?**
 -
- **What is the biggest issue with treating PFA?**

-
- **Was there something you were expecting us to ask that we did not?**
 - How does the brace impact gait?
 - The biggest thing functionally that people cannot do is going up the stairs

n. Ninestone Insurance Underwriter

Notes:

- She is worked in medical Reimbursement
 - Federal
 - DME (from a reimbursement and benefits perspective)
- Benefits
 - Covered by parents for insurance
 - Benefit description from company
 - Description of benefit
 - Durable medical equipment
 - Sometimes orthotics is covered~
- Reimbursement
 - How much the provider bills ~ relationship with the manufacturer?
 - How much is the allowed amount?
 - Based on the arrangement with stat, fed gov
 - Almost always a cost share involved
 - Can be a co-pay
 - Or co-insurance (percent of the allowed amount) ~10-20%
- Through the process to get on the approved list
- Step 1
 - Find a manufacturer
 - Who are doing another orthotics?
 - Sell the patent
 - GO through their process
- If starting a company
 - Different struggle
- Has other friend in med devices
 - She may have additional insight on how to break into the market/door for getting the knee brace approved.
 - However typically done through **manufacturing**
- Xcel Orthopedics <https://www.excelortho.com/>
 - Distributor~ Would use the knee brace
 - Might be a good avenue to get the “how do we make it happen?”
- Mass Gen
 - Big orthopedics practice - sports injury
- All the big integrated one
 - Partners
 - Bigham
 - Etc
 - All have divisions or orthopedic specialty division

o. Fallon Health Insurance Underwriter

Working now in medical and payment policies

Medical policies—determine what is covered

Payment policy—is the billing information using CPT codes

CPT codes usually used for surgery and x-rays and lab tests

HPCS- billed for orthotics

How do the codes work?

Patient goes to the doctor for knee pain and the doctor recommends a brace—needs prior authorization

Supplier will file a claim

Gives insurance company all the information

How does a brace get covered?

We would have to work with the supplier

How does your company go about deciding whether or not to include access to braces within their coverage?

They have criteria that they follow

9/10 patients use Medicare criteria

Like consistency—easier across the board for everyone involved

Off the shelf orthotics—require little adjustment

Custom orthotics have different codes

All have unique codes

There are all kinds of rules for orthotics

Health insurance companies follow Medicare guidelines

Medicare population is the ones that use insurance the most

Who makes codes?

CMS

For CPT codes – American medical association

HCPS codes – CMS

Need to look If the device will fit a code

Each code has an unspecified code as well

All policies are posted on Fallon website

CMS.gov has a lot of valuable information

Manuals

Internet only manuals

Medicare claims processing manuals

Durable medical equipment

Shows how orthotics are covered

Only prior auth things that can be abused – usually expensive or customized
Lab tests are not usually prior auth, but genetic testing is prior auth

CMS website – you can search off the shelf

- Describes off the shelf orthotics

- Has list of off the shelf codes

Can google codes for more information

If we cannot find a code that is off the shelf our brace might be custom

DMEPOS quality standards – google

- First link

- Educational article

- Follow appendix C

Diagnosis code M17.9

- p. Milford Regional Physician Group Employee
- **How long have you been working with insurance offerings and/or processing of claims associated with sports and specifically knee injuries?**
 - Milford regional physician group- 170 physician, director of billing, responsible for the whole physician billing process, there were coding who would review coding from the doctor's visit, 33 different sites, copays and balances on account which would go to a central location for daily deposits, the billers did follow up work and follow up with insurance if there was a payment error. Auditing department review medical records to make sure things that were billed are correct.
 - For a knee brace= coding- need a couple appointments, first visit would be that that is what is needed, then application of the brace, (a couple different of codes- cannot pay for application, but would go into doctors visit billing and the supply cost) then follow up visit to see how the brace was going.
 - **Is there a preferred treatment/ management for a condition?**
 - Injections, new therapies-take your own plasma then inject just the plasma cells into the area that needs repair, or Prolo therapy similar but not with blood, physical therapy- knee braces usually prescribed in conjunction, lots of patients would rather just the brace

q. Surgicare Bracing Specialist

Could you explain your job to us? In particular we are seeking to understand the sales cycle (Opportunity identification – Qualification – Sale – Post-sale) for braces and (if applicable) other products for treatment of knee pain/ injuries.

He is an orthotist. He works with people involved with braces. He sees people who are referred to him multiple times. He is usually brought in by a physical therapy / personal trainer. Been in the business 20 years.

How long have you been a medical sales representative and over that time, how have you seen the approach to treating knee injuries in general and patellofemoral arthritis specifically evolve?

He does more ACL type of bracing than anything else. Surgery is usually the best approach. Unloader braces are better, especially for arthritis. Such a brace would usually be in the office.

What measurements are taken when calibrating a knee brace?

He mainly determines height, weight, offset, medial - lateral distance.

What are the various “settings” for the braces “so-and-so” supplies?

Insurance has become difficult, mainly because of cost. Insurance is most of the time private. MDE (covers braces). Insurance has gotten smarter, less coverage, larger deductible from braces. Once through those obstacles, the service is acceptable. In insurance, the braces are usually \$100-200, for athletes, the braces can be as expensive as \$600-1000. More times than not, braces are usually off the shelf.

What is your most popular brace for treating people with arthritis underneath their patella?

Medial - lateral OA braces are mainly used. 70% are for the medial side. Arthritis braces are usually Medicare patients. These braces are in the realm of \$600 braces.

What population do you work with the most for knee pain?

Most popular: athlete for ACL
2nd popular: Older population with OA (osteoarthritis), they obtain it literally from anything (just walking, high activity, health issues, Q angle, **weight**, on and on)

What areas of the industry are strongest currently, and where do you feel are current unmet needs?

Everything is insurance driven, everything is documented, money driven, prices become less and less, the care becomes less effective. People often are not noticing a difference. People get desperate for a solution that is not surgery.

Who do you interact with the most when selling orthotics?

Always working with the provider, the doctor.

Was there something you were expecting us to ask that we did not?

Doctors do not really get any follow-up, they do not know about how the braces work, “if they work, they work”. Although people see patients, they never really are able to get accurate data with regards to the success of the brace. Follow-up is not there, hard to validate a brace. How compliant someone is to go through exercises, how successful a brace is.

Is there anyone that you would recommend we speak to about this? Would you be able to provide us with an introduction?

OA subset. With regards to meeting with patients with PFA (OA), ask Dr Deangelis, or a physical therapist if they can get us in contact with patients.

General notes

Don-Joy Tru pull (J brace) = that was a bigger one

Braces should always be work under clothing (or in contact with bear skins)

Chris has worked with Brady, Matt Lacosse and other patriots

BrightPTO makes braces. Check them out

Everyday use is lighter.

Lacking features in current braces: too complex (not simple enough), too heavy

If he

290-pound patient wore a brace for 9 years, and it has worked out for him

Take the patella off the condyle = it would definitely be a challenge, but it could be a great potential short-term solution.

II. CAD drawings

a. Gen 1 Subassemblies

i. Hinge Subassembly

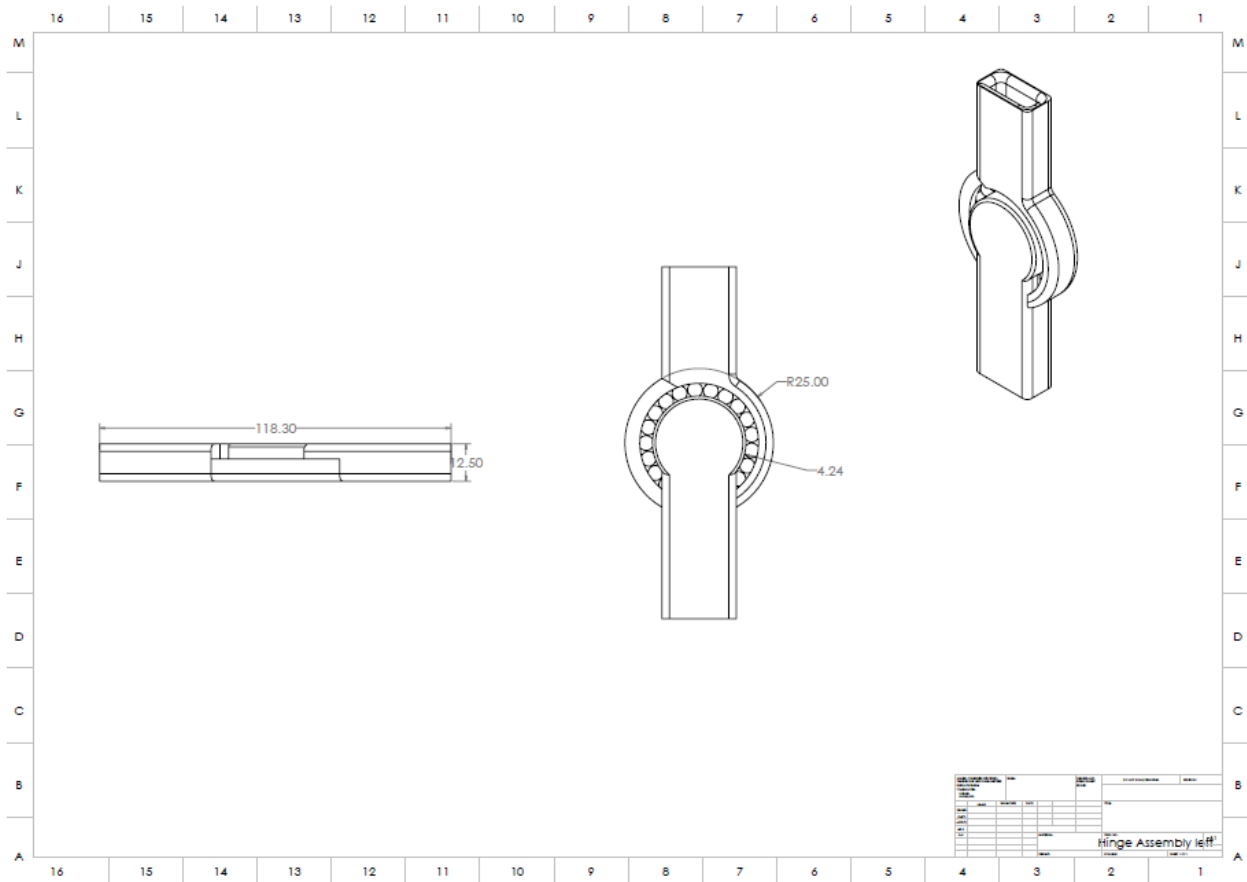

Figure 42: Gen 1 Hinge Subassembly Drawing in mm

As shown in Figure 42, the design intent of this subassembly was to provide the overall rigid brace the ability to bend with the flexion of the knee up to 105 degrees. There were upper and lower parts of the hinge. The ball bearings were set into a circular groove offset to the outside to allow for the connectors to rotate past one another. The inclusion of ball bearings was intended to allow for smooth rotation. Unfortunately, the connector pieces limited the rotation to 105 degrees.

ii. Upper

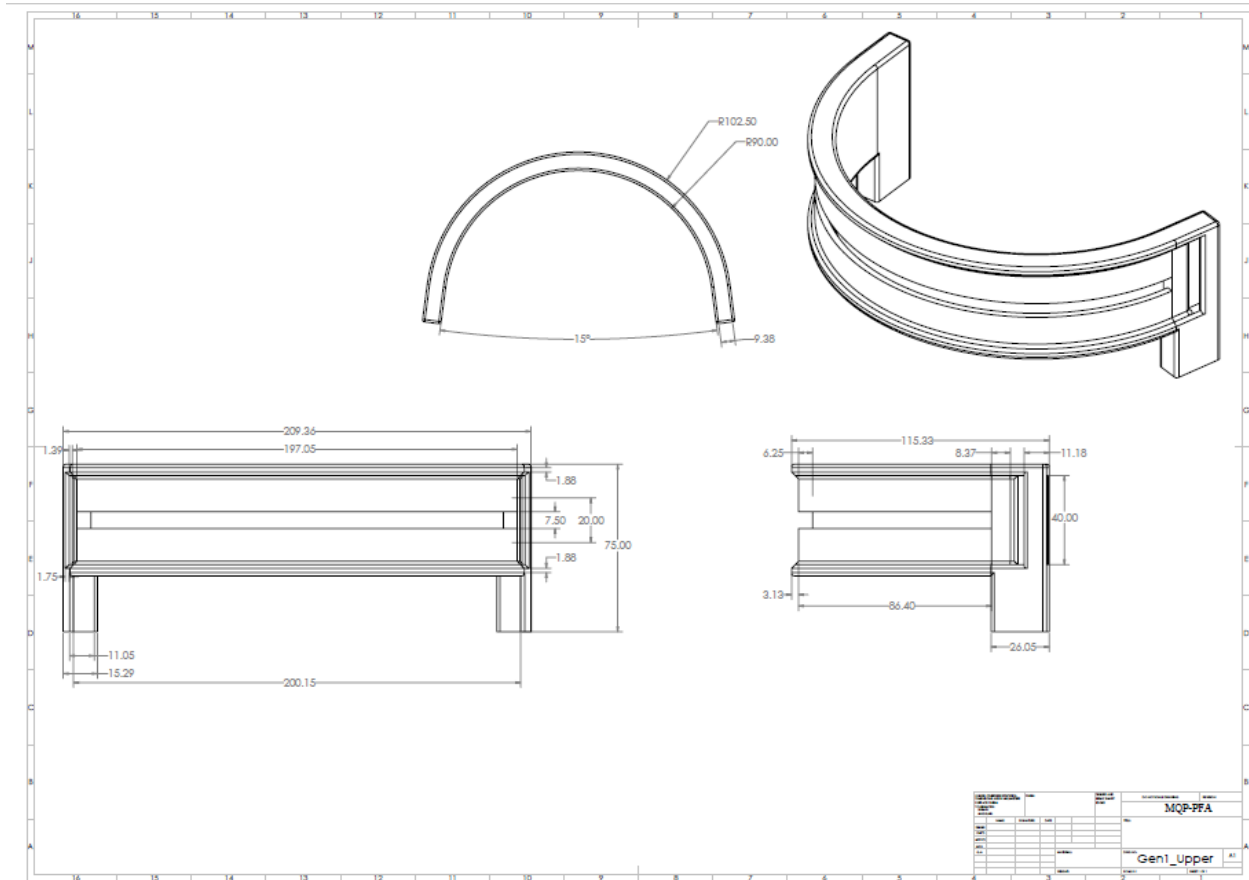

Figure 44: Gen 1 Upper in mm

As shown in Figure 44, the upper part of the rigid body was designed to fit the dimensions of a human thigh. It includes a rail system to allow the ratchet placement to be adjustable. This design also includes a slit on both sides for a strap to be used to secure the rigid brace to the leg and press fit indents for the connector pieces.

iii. Lower

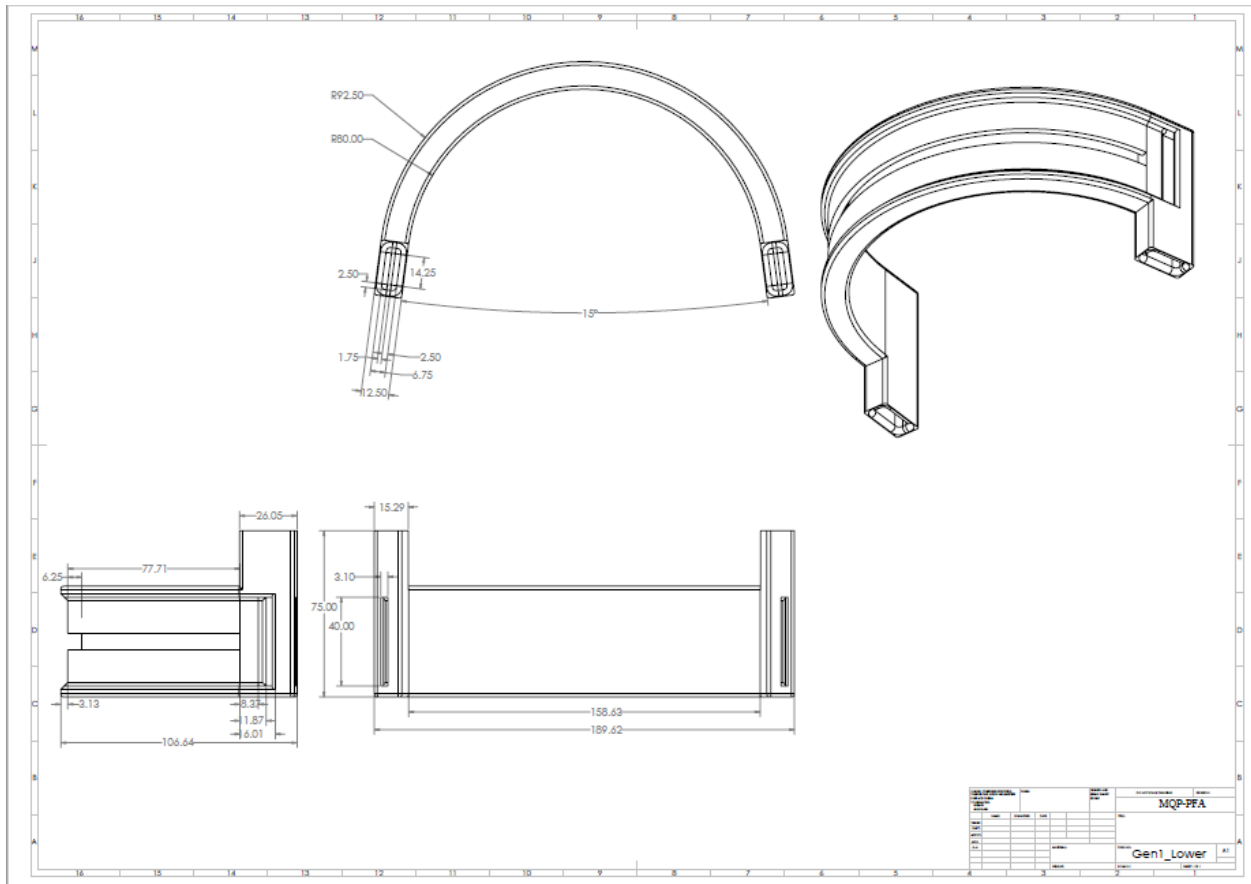

Figure 45: Gen 1 Lower in mm

As shown in Figure 45, the lower part of the rigid body was designed to fit the dimensions of a human shin. It includes a rail system to allow the ratchet placement to be adjustable. This design also includes a slit on both sides for a strap to be used to secure the rigid brace to the leg and press fit indents for the connector pieces.

iv. Upper Connector

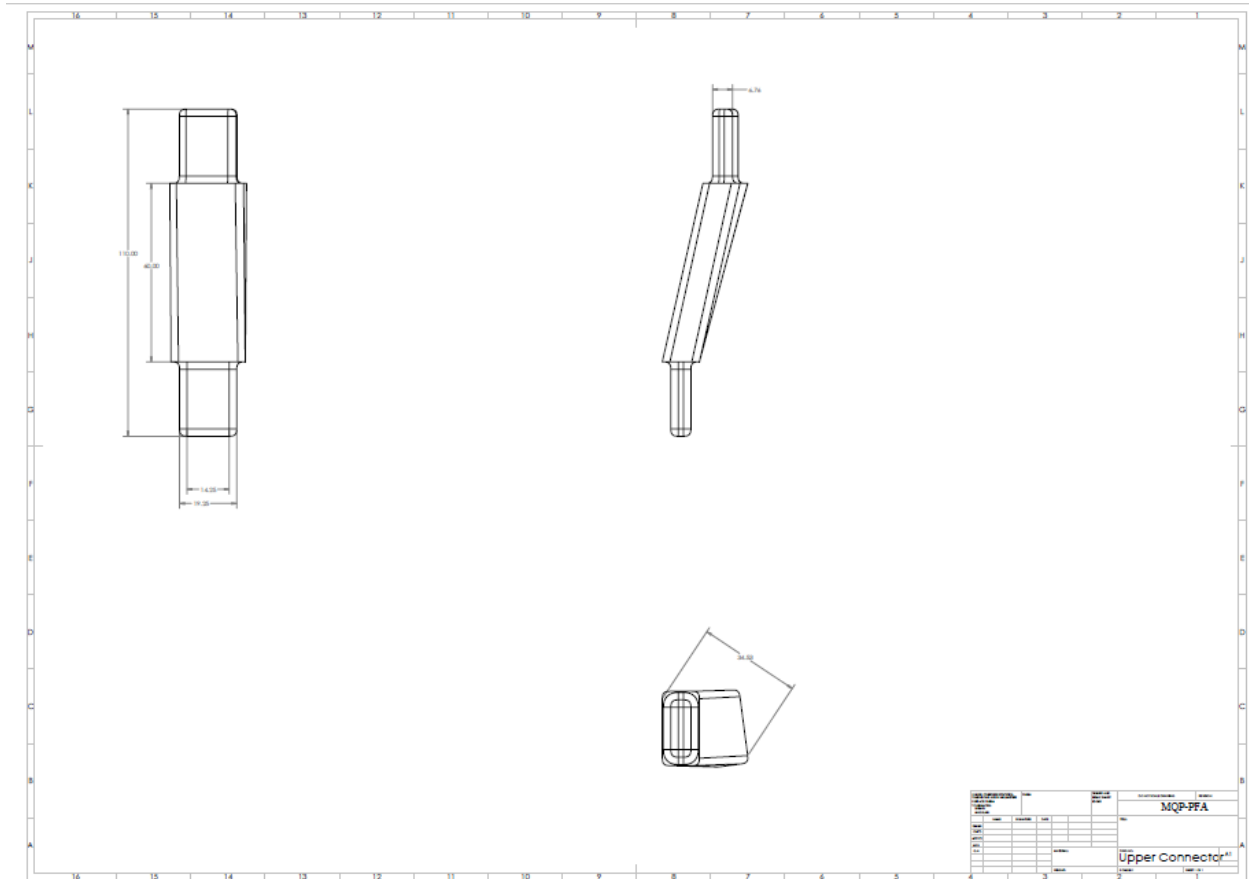

Figure 46: Gen 1 Upper Connector in mm

As shown in Figure 46, the upper connector piece was designed to connect the upper component to the ball bearing hinge. This design is molded to follow the changing diameter and angle down the side of the thigh to the side of the knee joint such that the brace can stay flush to the leg.

v. Lower Connector

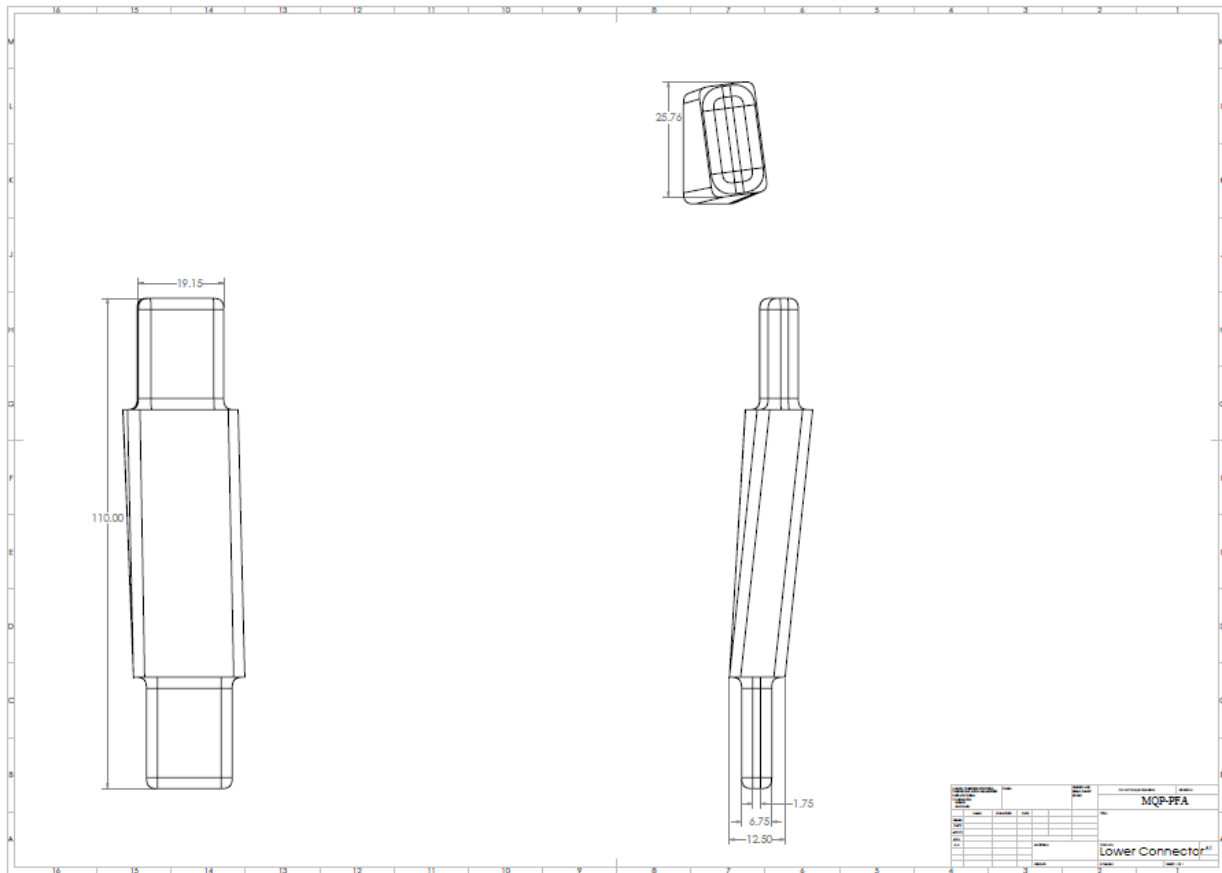

Figure 47: Gen 1 Lower Connector in mm

As shown in Figure 47, the lower connector piece was designed to connect the lower component to the ball bearing hinge. This design is molded to follow the changing diameter and angle down the side of the calf to the lower component about the shin such that the brace can stay flush to the leg.

1. Hinge Inner

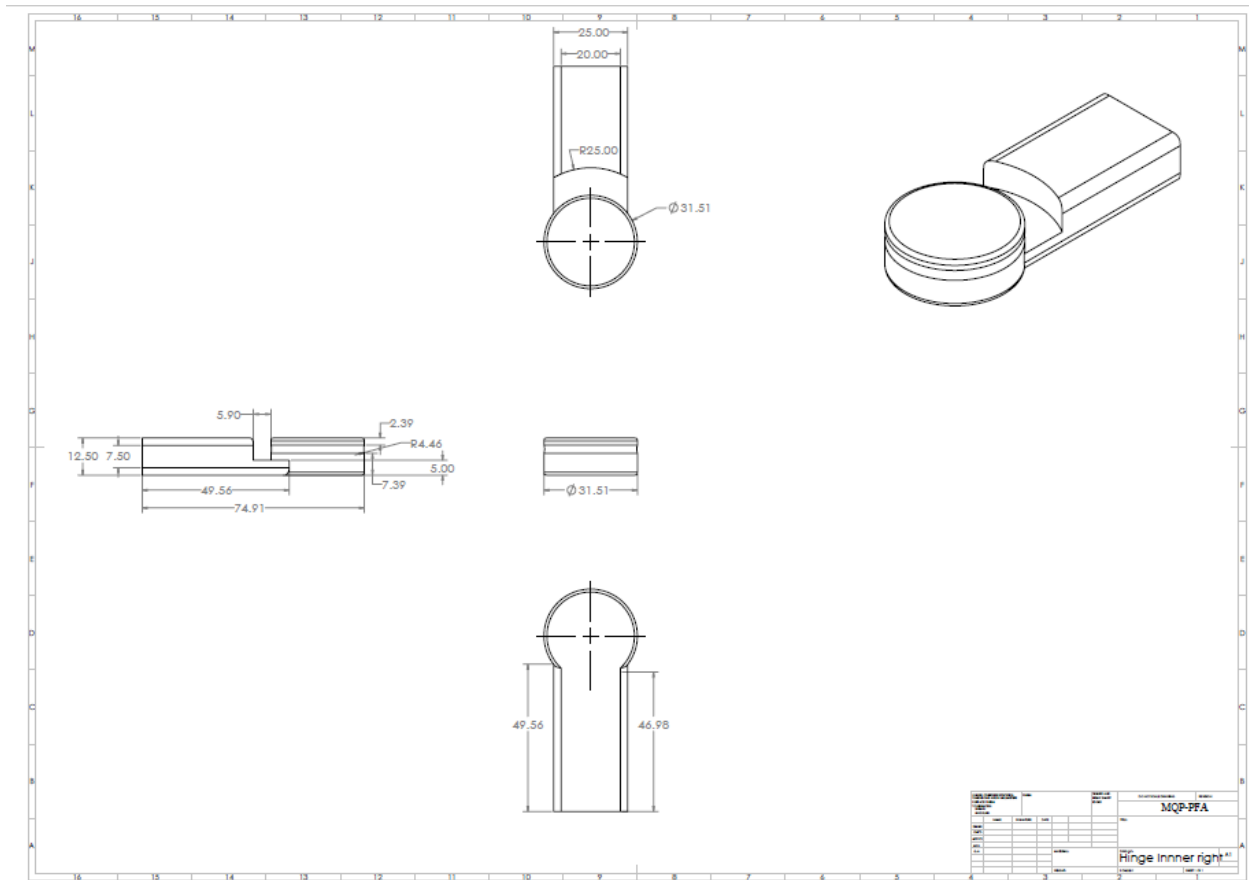

Figure 48: Gen 1 Hinge Inner in mm

As shown in Figure 48, the inner hinge is the component of the hinge joint flush to the leg. This bottom component of the joint is designed such that there is a groove for the ball bearings to move about and the top component of the hinge to freely rotate.

2. Hinge Outer

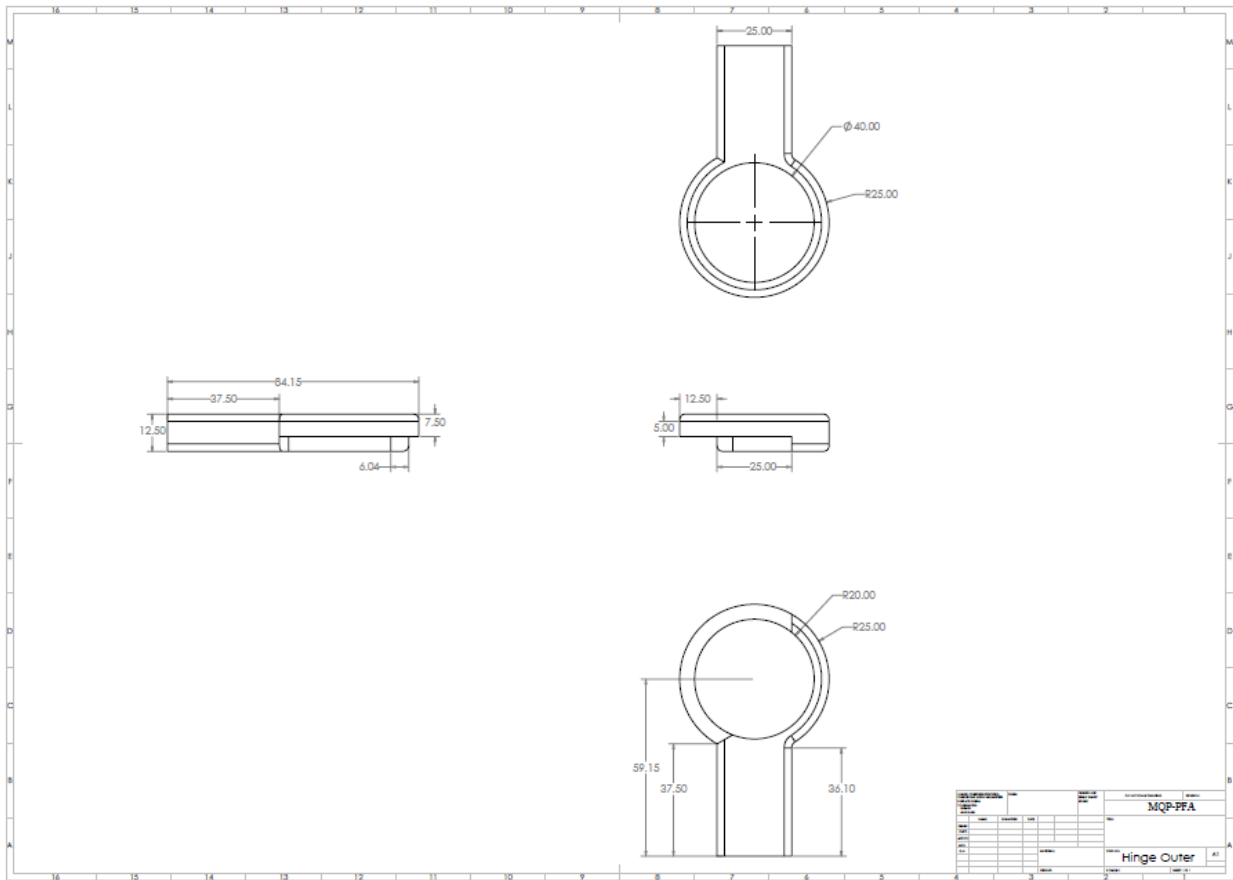

Figure 49: Gen 1 Hinge Outer in mm

As shown in Figure 49, the outer component of the hinge joint is designed to be the outer groove that holds the ball bearings in place with the back component as the inner radius. This component also has a cut out to allow the outer and inner hinge to move over each other without interference so that the hinge can achieve 105 degrees of rotation.

c. Gen 2 Subassemblies

i. Pin Hinge Joint Subassembly

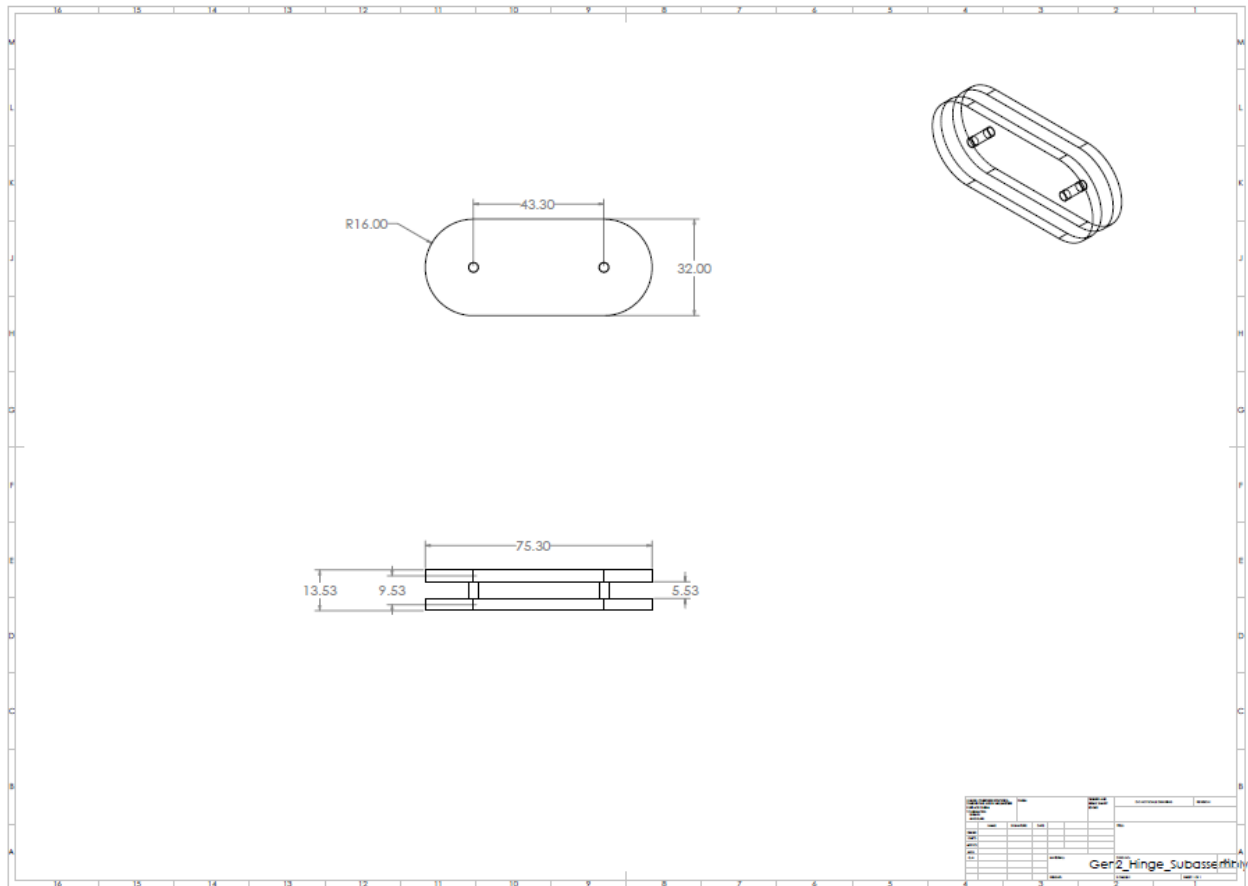

Figure 50: Gen 2 Pin Hinge Subassembly Drawing in mm

As shown in Figure 50, the second-generation hinge joint was designed to increase simplicity, manufacturability, and degrees of rotation. With this design, a dowel will be glued to the front and back components with the upper and lower components to rotate about the dowels.

ii. Gen 2 Parts

1. Upper

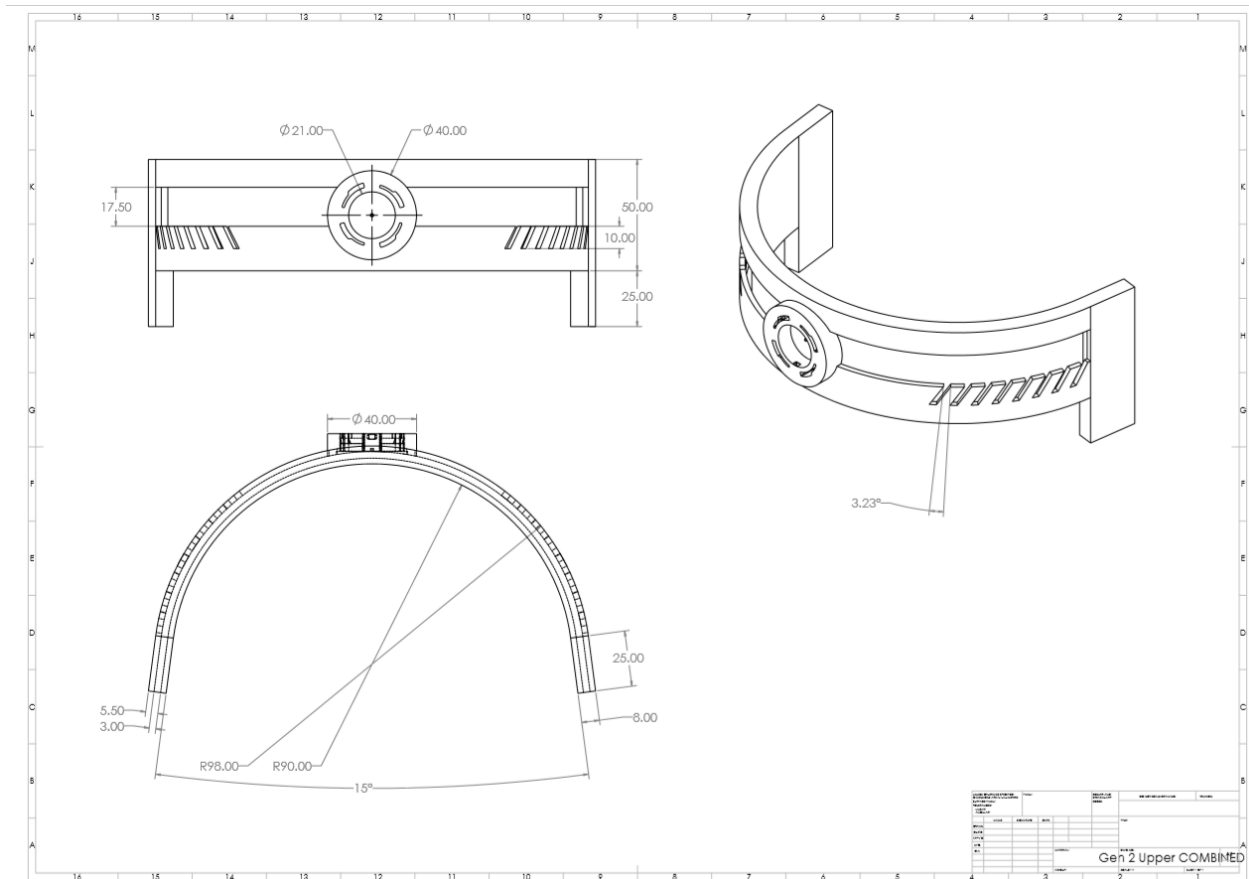

Figure 51: Gen 2 Upper Drawing in mm

As shown in Figure 52, the Gen 2 Upper component contains a few new features compared to its Gen 1 counterpart. The wire anchor features are located on either side of the brace with respect to the front view and allow for easy user adjustment of the angle of the wires for securing the wires to a fixed point. The ratchet anchor, located at the center of the upper component with respect to the front of the brace, allows for a sturdy, fixed location to push-fit the BAO H-series ratchet into.

2. Lower

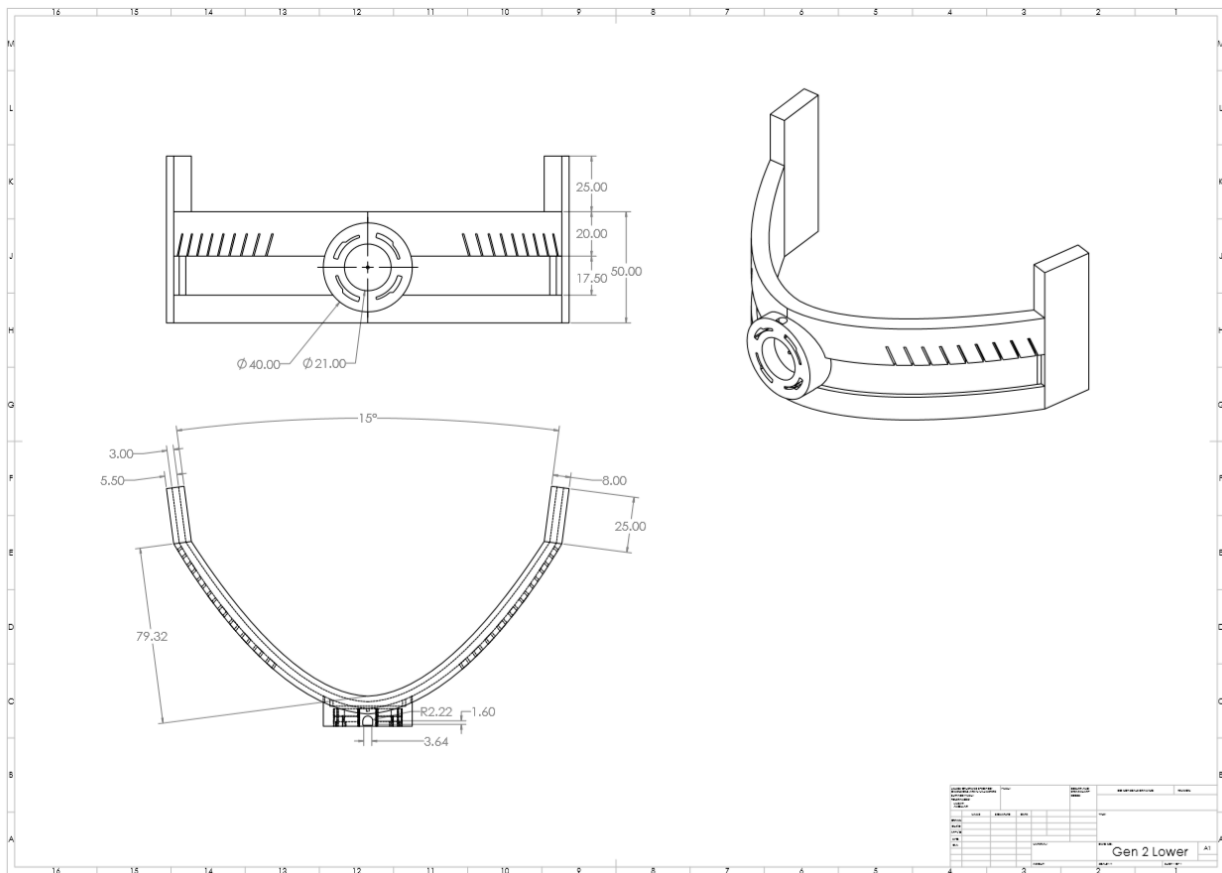

Figure 52: Gen 2 Upper Drawing in mm

As shown in Figure 52, the Gen 2 Lower component contains a few new features compared to its Gen 1 counterpart. The wire anchor features are located on either side of the brace with respect to the front view and allow for easy user adjustment of the angle of the wires for securing the wires to a fixed point. The ratchet anchor, located at the center of the upper component with respect to the front of the brace, allows for a sturdy, fixed location to push-fit the BAO H-series ratchet into. Additionally, the Gen 2 Lower component has a unique curve allowing for better conformance with a human shin compared to the Gen 1 counterpart.

3. Upper Connector

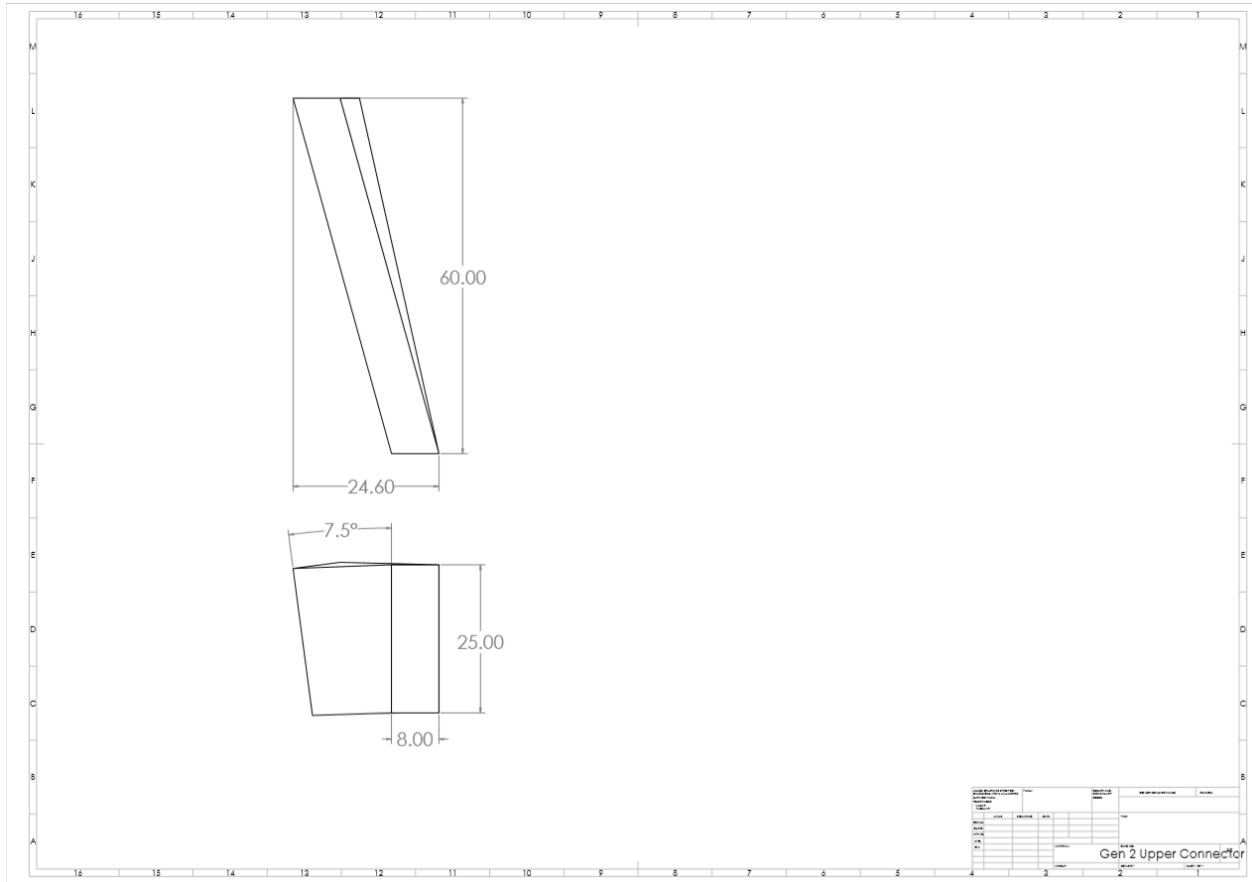

Figure 53: Gen 2 Upper Connector Drawing in mm

As shown in Figure 53, the upper connectors were 60 mm long extrusions of an 8 by 25 mm rectangle. The purpose of the connector was to link the upper part with the hinge joint. To do this the lower have had to be twisted 8.5 degrees and shifted inwards by 15 mm.

4. Lower Connector

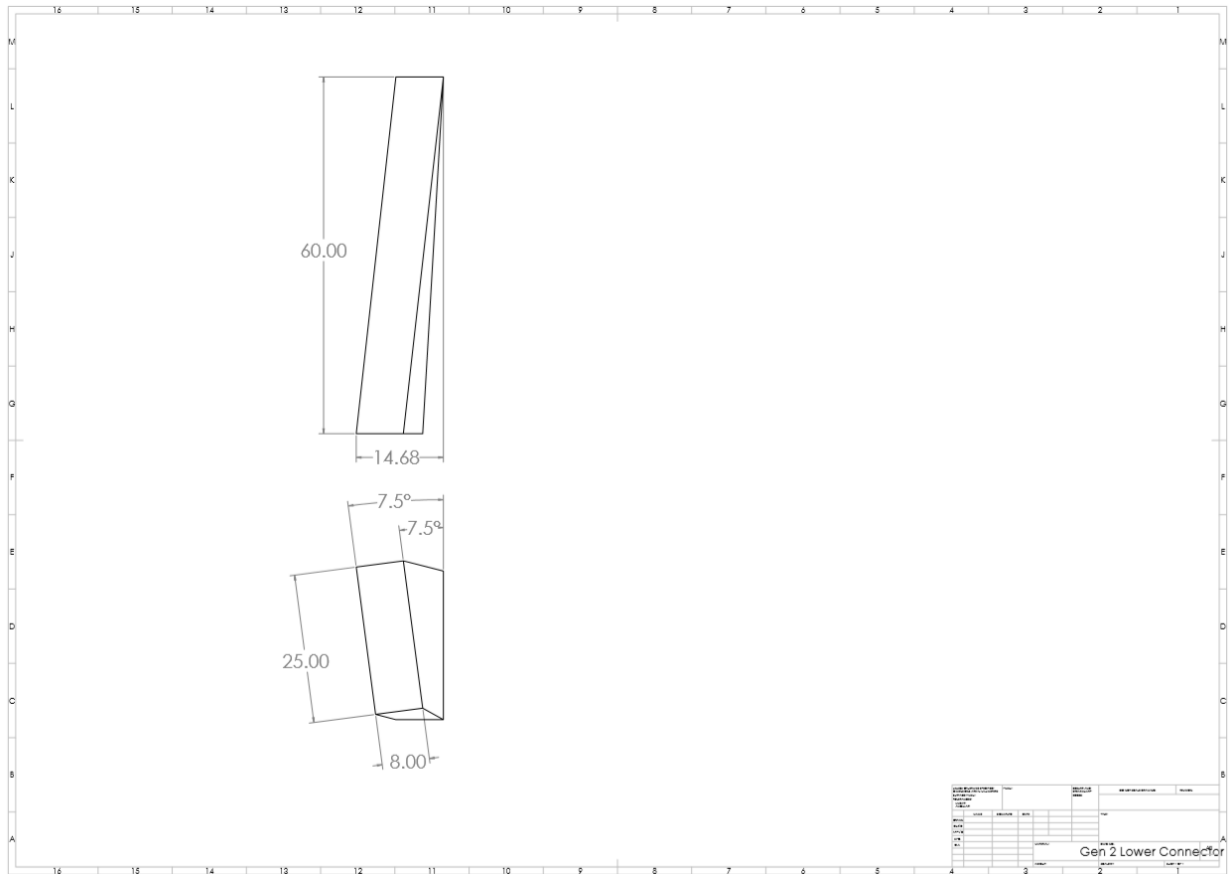

Figure 54: Gen 2 Lower Connector Drawing in mm

As shown in Figure 54, the lower connectors were 60 mm long extrusions of an 8 by 25 mm rectangle. The purpose of the connector was to link the upper part with the hinge joint. To do this the lower have had to be twisted 8.5 degrees and shifted inwards by 5 mm.

5. Hinge

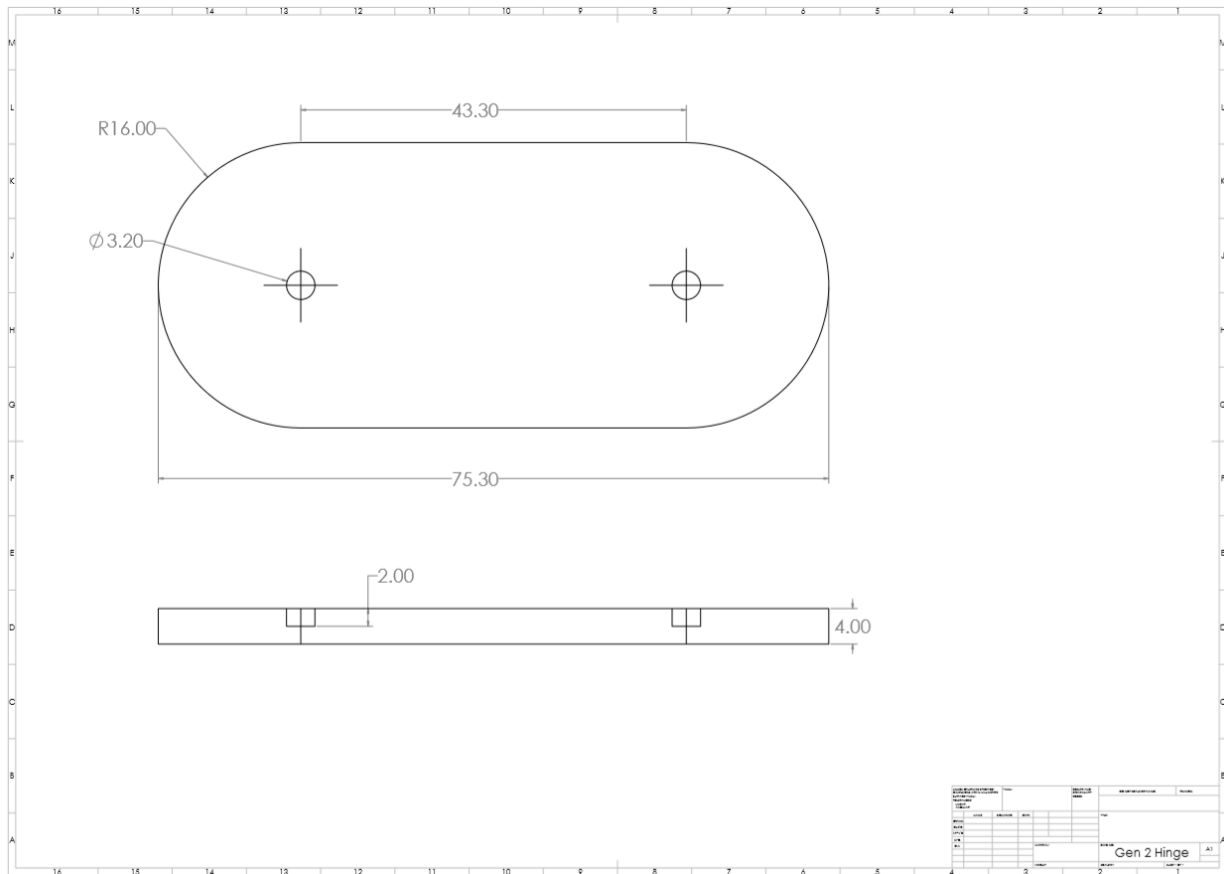

Figure 55: Gen 2 Hinge Drawing in mm

As shown in Figure 55, the hinge part was made to serve as the anchor for two pins, to allow for a huge range of flexion for any connector piece place between two hinges, depending on their dimensions. The hole is set at a radius of 3.2 mm, which leaves little room for a 3 mm radius pin.

6. Hinge Pin

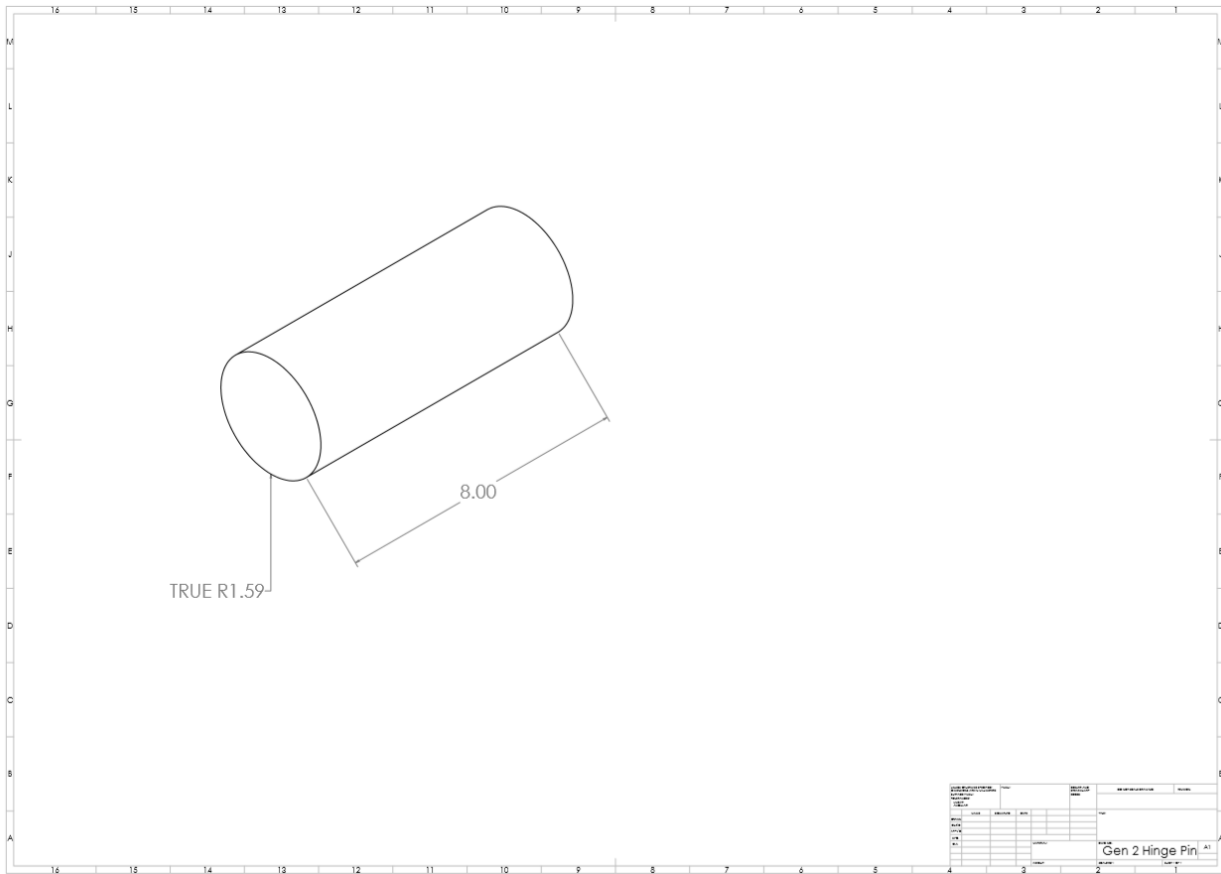

Figure 56: Gen 2 Hinge Pin Drawing in mm

As shown in Figure 56, the pin is 8 mm long with a radius of 3 mm. It is meant to be used in tandem with two hinge pieces and a hinge connector.

7. Hinge Connector

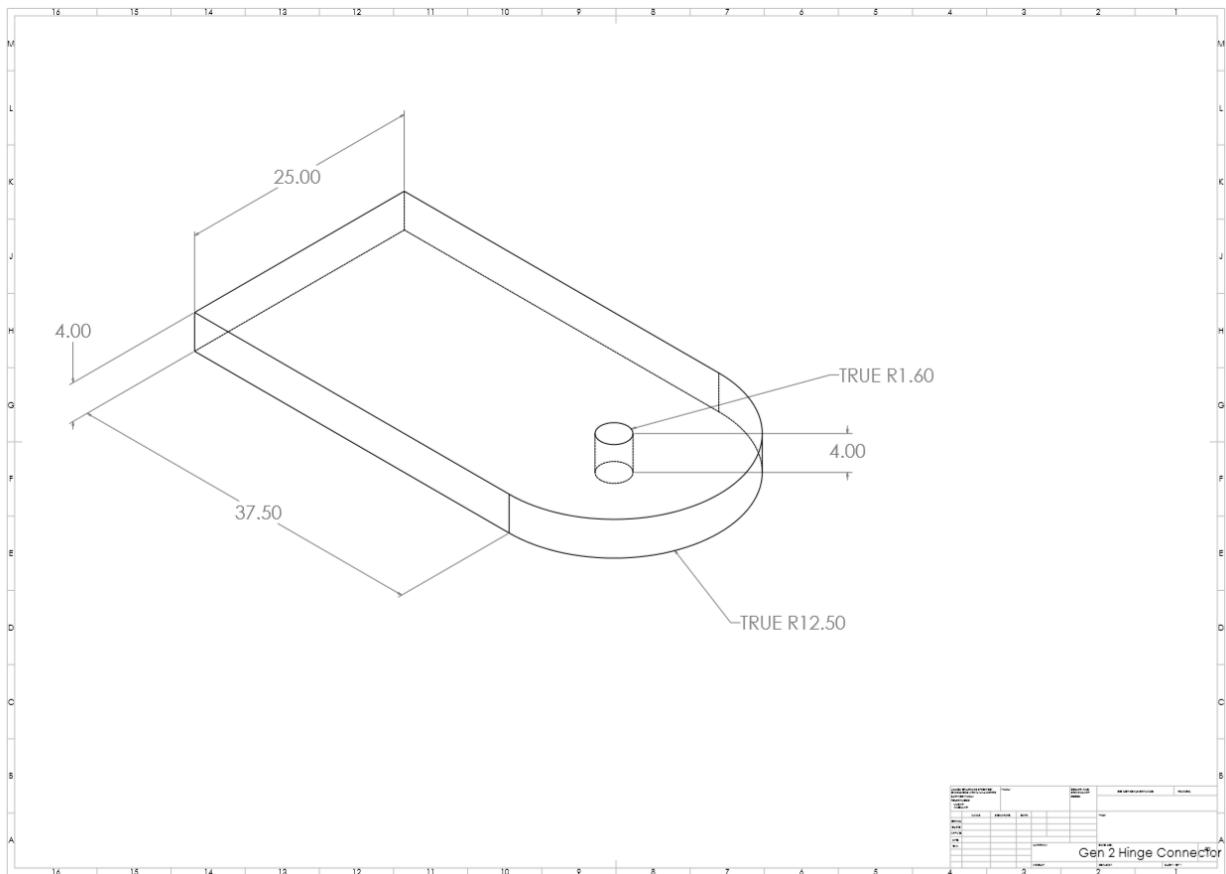

Figure 57: Gen 2 Hinge Connector Drawing in mm

As shown in Figure 57, the hinge connector is meant to be attached to the upper and lower connectors. It works to connect the upper and lower parts of the rigid body to each other through the hinge via the hinge pin.

8. Ratchet Anchor

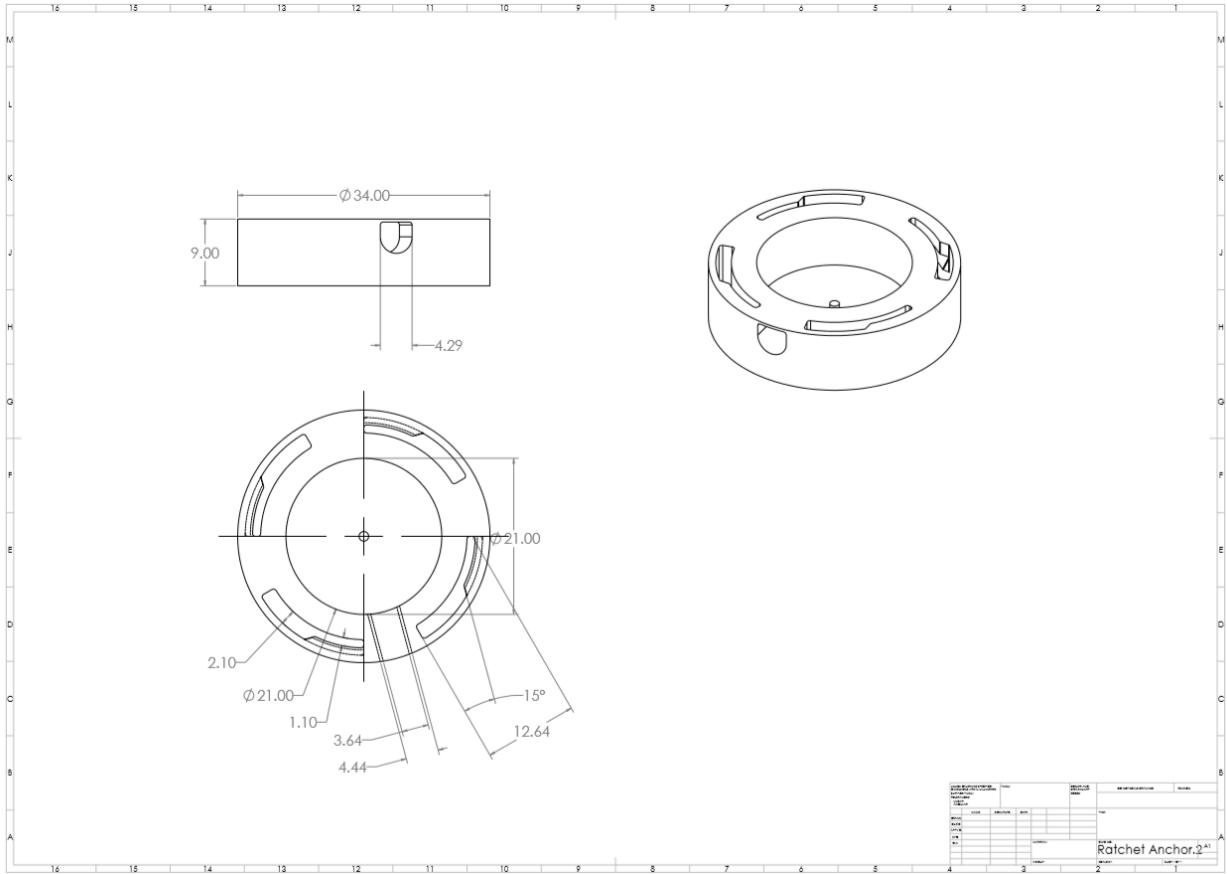

Figure 58: Gen 2 Ratchet Anchor Drawing in mm

As shown in Figure 58, the Gen 2 Ratchet Anchor is intended to secure the ratchet into place, while still allowing the wire to be reeled-in and released with ease.

d. Gen 4 Parts

i. Gen 4 Upper Combined

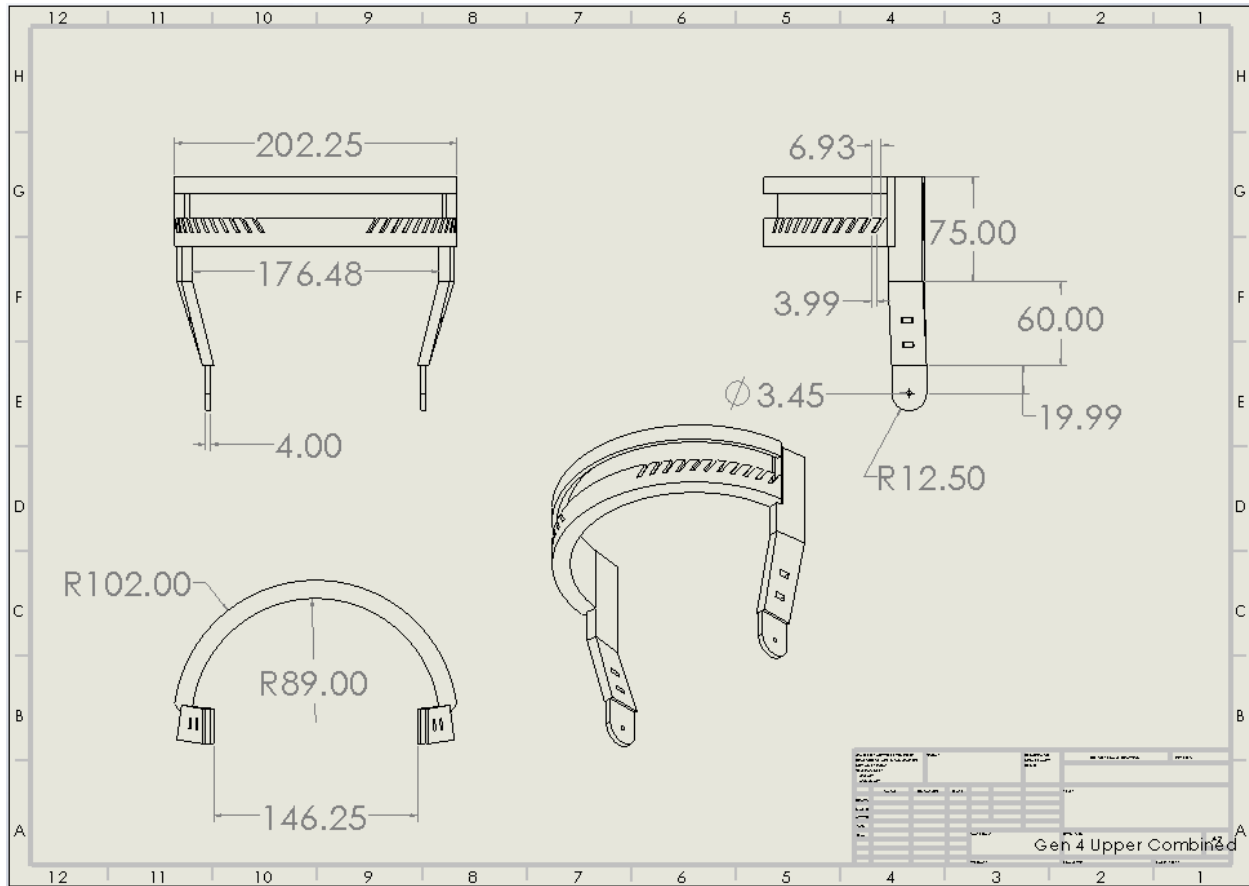

Figure 59: Gen 4 Upper Combined in mm

As shown in Figure 59, the third Generation of the device was skipped in naming. The reason for this was due to the similarities with Generation 2. Instead Generation 3 was just merged with Generation 2. However, Generation 4 was significantly different.

The biggest change for the upper part was the change in ratchet placement. There no longer was a ratchet holder on the upper portion of the brace - instead the main purpose of Upper was to act as the anchor for the wire. Another change was that the connector pieces were merged with the upper portion of the brace. Additionally, two holes were added within each connector. These holes functioned as an interface for rubber bands to interact with and help the ratcheting system.

ii. Gen 4 Lower Combined

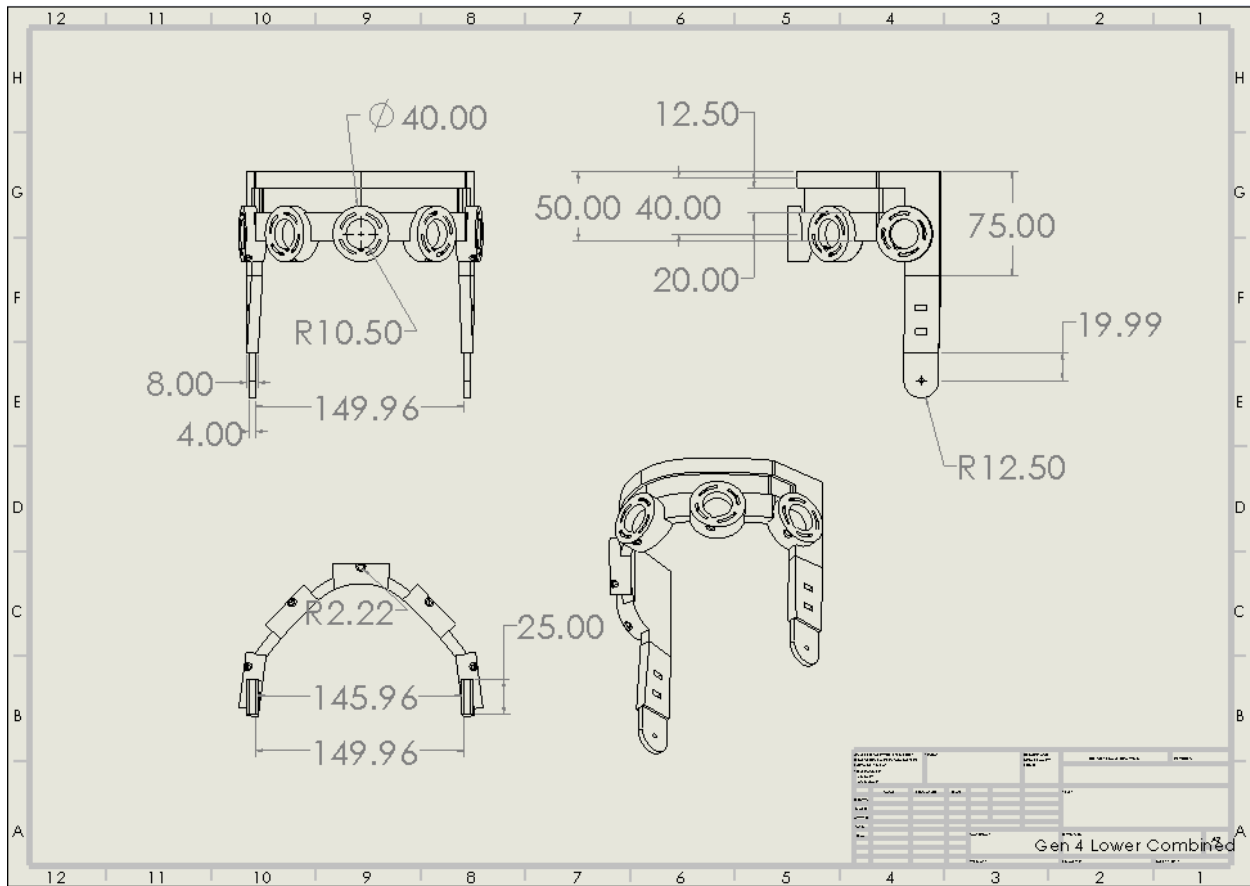

Figure 60: Gen 4 Lower Combined in mm

The biggest change in the Gen 4 Lower, was the replacement of the wire anchors with ratchet holders. As shown in Figure 60, the Lower part also had the connectors attached and adapted to include the rubber band holes. The main purpose of the Lower part now revolved around the placement of the ratchets.

iii. Gen 4 Hinge

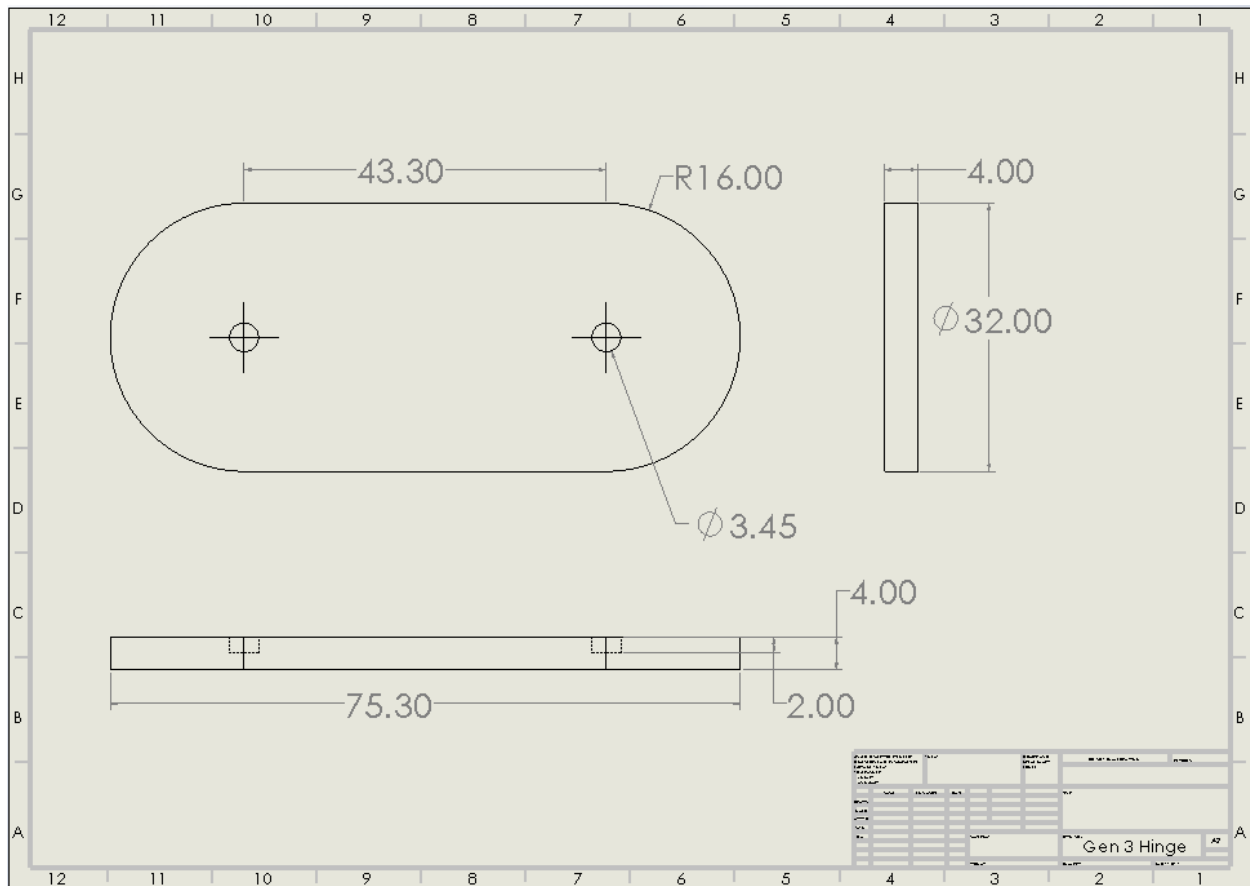

Figure 61: Gen 4 Hinge in mm

As shown in Figure 61, the dimensions of the Gen 4 Hinge changed slightly from the 2nd and 3rd generations to better fit the 4th Generation.

iv. Hard C-clamp



Figure 62: Generation 4 C-clamp

As shown in Figure 62, the c-clamp has a curved geometry which is used to wedge between the patella and the femur. There are two holes through the clamp to allow for the rubber bands to attach to.

v. Anchor Hook

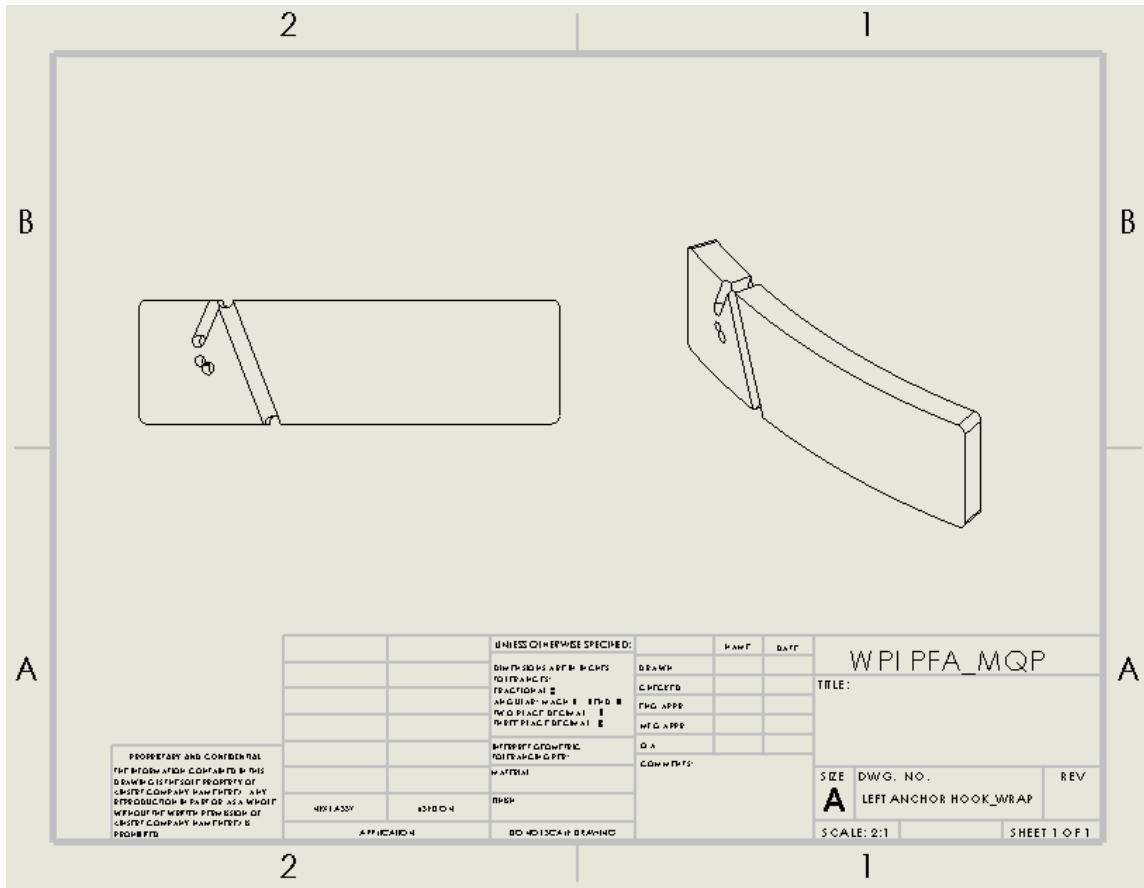

Figure 63: Generation 4 Anchor Hook

As shown in Figure 63, the function of the anchor hook was to hold the wire in place within the Upper portion of the brace. The wire is looped through and wrapped around the anchor hook.

vi. Gen 4 Hinge Pin

Same as Gen 2 Hinge Pin. See Appendix 11.2.4.6.

III. Test Methods

a. TM-01

TM-01 Measuring Brace's Ability to Prevent Patellar-Femoral Contact using CT Scanners

Purpose: The purpose of TM-01, is to evaluate the prototype against DR-01. In order to accomplish this, we will observe whether or not the knee brace minimizes contact between the patella and the knee, and if contact minimization occurs, measure the distance between the two. The team will satisfy this measurement by visually observing CT scans of the patellofemoral joint while the brace is worn by a fully extended goat leg.

Materials:

The following materials will be required for the CT Scanning portion of this test method:

- CT scanning equipment
- Animal knee joint model (goat)
- The prototype knee brace (sized for the goat)

Safety Precaution:

Proper Personal Protective Equipment (PPE) should be worn throughout the duration of the procedure. This equipment consists of rubber gloves, lab coat, and safety glasses. Only handle the animal model when wearing all stated PPE. The CT scanner is a relatively safe machine to use, only utilizing a small amount of x-ray radiation to produce cross sectional images. However, this x-ray radiation poses a slight chance of developing health issues from radiation exposure. Additionally, dissection equipment will be needed. Take precautionary measures to ensure that the surgeons do not harm themselves with the sharp equipment required for dissection.

Procedure:

A negative and positive control will be performed to compare experimental values to. Force applied to the knee joint on each side will be adjusted to meet the conditions of Table 1. .

Table 12: Brace Configurations

Trial #	Wire Orientation	C-clamp Type	Ratchet Level
1	No Brace	N/A	N/A
2	Brace	N/A	N/A
3	Across	Hard	Secure
4			90 degrees
5			180 degrees
6	Same	Hard	Secure

7			90 degrees
8			180 degrees
9	Across	Hybrid	Secure
10			90 degrees
11			180 degrees
12	Same	Hybrid	Secure
13			90 degrees
14			180 degrees
15	Across	Soft	Secure
16			90 degrees
17			180 degrees
18	Same	Soft	Secure
19			90 degrees
20			180 degrees

Because of unexpected complications the team was only able to complete tests 1-14.

Negative Controls Procedure:

1. Place the goat knee joint model into the CT Scanner
2. Capture CT image of the model

Positive Control Procedure:

1. Place the brace, not engaged, on the leg.
2. Capture CT image of the model

Tests 3 to 5:

1. Place the brace in the goat leg with the hard clamp on.
2. Anchor the wire at the top of the brace on the opposite side that the corresponding ratchet is on.
 - a. After this is done for both ratchets, tighten until the c-clamps are secure on to the goat leg, this will be the secure orientation. Place the goat leg into the scanner
 - b. After this scan is complete, tighten both ratchets 90 degrees as indicated by Figure 64.
 - c. After this scan is complete, tighten both ratchets another 90 degrees as indicated by Figure 65.



Figure 64: 90 degrees of rotation



Figure 65: 180 degrees of rotation

Tests 6 to 9:

1. Place the brace in the goat leg with the hard clamp on.
2. Anchor the wire at the top of the brace on the same side that the corresponding ratchet is on.
 - a. After this is done for both ratchets, tighten until the c-clamps are secure on to the goat leg, this will be the secure orientation. Place the goat leg into the scanner
 - b. After this scan is complete, tighten both ratchets 90 degrees as indicated by figure 64.
 - c. After this scan is complete, tighten both ratchets another 90 degrees as indicated by figure 65.

Tests 9 to 11:

3. Place the brace in the goat leg with the hybrid clamp on.
4. Anchor the wire at the top of the brace on the same side that the corresponding ratchet is on.
 - a. After this is done for both ratchets, tighten until the c-clamps are secure on to the goat leg, this will be the secure orientation. Place the goat leg into the scanner
 - b. After this scan is complete, tighten both ratchets 90 degrees as indicated by figure 64.
 - c. After this scan is complete, tighten both ratchets another 90 degrees as indicated by figure 65.

Tests 12to 14:

5. Place the brace in the goat leg with the hybrid clamp on.
6. Anchor the wire at the top of the brace on the opposite side that the corresponding ratchet is on.
 - a. After this is done for both ratchets, tighten until the c-clamps are secure on to the goat leg, this will be the secure orientation. Place the goat leg into the scanner
 - b. After this scan is complete, tighten both ratchets 90 degrees as indicated by figure 64.

- c. After this scan is complete, tighten both ratchets another 90 degrees as indicated by figure 65.

Hypotheses for CT Scanner:

Alternative Hypothesis: Our team believes that with increased pressure applied to the medial and lateral sides of the patella while the leg is fully extended, the patella will become more distanced from the femur compared to the negative control group.

Null Hypothesis: There will be no change in patella-to-femur distance between the experimental and control groups.

Analysis for CT Scanner:

When considering the legitimacy of the results gathered from an experiment, it is important to statistically compare the data. The method used will be a linear regression. For each trial, the ratchet will be cranked more and more. The distance between the patella and the femur will be measured with each trial. The data will be represented via a ratchet rotation (degrees) vs patellar-femoral distance (mm) graph.

Success Criteria for CT Scanner:

Success for this test will be determined by whether or not our team proves our hypothesis, that the patella will be distanced from the femur when the brace is activated.

- b. Kinematic Tracking Test

Objective: The purpose of this test was to compare the effect that the prototype brace has on patellar lift during flexion to that of a patella uninfluenced by the brace.

Kinematic Tracking Procedure Overview:

The software used to capture the data electromagnetic positional data is called PiMgr which quantifies the positional data of the Polhemus motion capture equipment. The Polhemus equipment included the Polhemus hub and the positional sensors. Controlled magnetic fields are generated by a fixed transmitter, called the Polhemus Hub, which are detected by the receivers, called the Polhemus sensors, that are fixed on the goat leg via electromagnetic sensors. The sensors were inserted into bone in the specified places as listed in Table 13. This configuration was set up to ensure the positional data obtained met the test objective.

Table 13: The locations of each sensor are denoted below in order to properly analyze the movements of the subject.

Hub	On the source box, serving as the global coordinate location of (0,0,0).
Sensor 1	Attached to the femur approximately along the sagittal plane of the goat leg using bone screws
Sensor 2	Approximately the center of the patella
Sensor 3	Attached to the tibia approximately along the sagittal plane of the goat leg using bone screws

Several brace configurations were tested by placing the brace on the sensed goat leg. The below table 14 shows the test matrix used for the experiment.

Table 14: The Test Matrix used for the test including the experimental trials, 3 through 20, and the control trials, 1 and 2.

Trial #	Wire Orientation	C-clamp Type	Ratchet Level
1	No Brace	N/A	N/A
2	Brace	N/A	N/A
3	Across	Hard	Secure
4			90 degrees
5			180 degrees
6	Same	Hard	Secure
7			90 degrees
8			180 degrees
9	Across	Hybrid	Secure
10			90 degrees
11			180 degrees

12	Same	Hybrid	Secure
13			90 degrees
14			180 degrees
15	Across	Soft	Secure
16			90 degrees
17			180 degrees
18	Same	Soft	Secure
19			90 degrees
20			180 degrees

The team chose three brace configuration settings to compare to one another as Independent Variables. These 3 included Ratchet Activation level, Wire Orientation, and c-clamp Type. Ratchet Activation Level included three levels: A Secure level where the ratchets are rotated until the c-clamps barely made contact with the patella, and two other levels, called 90 degree and 180 degree, which rotated the specified amount of degrees past the secure level. Wire orientation included two variations: one where the wires from each ratchet anchored themselves on the same side of the wire's ratchet location, and one where they anchored themselves on the opposite side, called the Same and Across orientations respectively. C-clamp type included 3 different types: The Hard clamp type was 3D printed out of PLA, the Soft type was made from a compressible pencil grip, and the Hybrid type was a combination of the Hard and Soft types. Our test matrix included every combination between our 3 independent variables, as well as a negative control, where the brace was not placed on the goat leg, and a positive control, where the brace was placed on the goat leg, but without any manipulation by the brace itself. As shown on the right, testing each trial once would equate to a total of 20 trials, which is what was attempted with the CT imaging test, while testing every trial twice would account for 40 trials total, which is what was attempted with the Kinematic Tracking test.

Set-up procedure:

1. Predrill holes into the femur, tibia, and patella .
 - a. Dissect the animal model down to the surfaces of the femur, patella, and tibia.
 - b. Drill holes into each of those respective bones to anchor the metal pins.
2. Fit screws through the sensor's attachment holes.
3. Drill the screws into the femur, tibia, and patella through the predrilled holes
4. Check to make sure that the screws and sensors are securely anchored to the bones.
5. Before proceeding, the hub needed to be paired with the PiMgr program.
 - a. To test that the program is synced to the tracking system, the PiMgr software should be opened. Click OPEN and then APPLY to identify the correct configuration of the kinematic tracking source. Choose the most recent file with the extension “.g4c”
6. Have the subject stood within the +x hemisphere of the global coordinate system (in front of the sensor).
7. Turn on the source and hubs, with the software program running.
 - a. The hubs should appear in the software, as well as their corresponding sensors.
8. Use some sort of marker to determine when full extension and full flexion is reached. In this case, tape was used to pinpoint where these regions were in space.
9. Before recording a real test, flex the goat knee with the sensors attached to it to ensure that the PiMg Tracking Configuration software is able to identify each sensor and its movement.

Testing procedure for each trial in test matrix:

1. Set the PiMg software to record measurements in millimeters (mm)
2. Set the necessary configurations for the trial (c-clamp type, wire orientation, ratchet activation level).
3. Fit the knee brace onto the goat leg model.
 - a. The goat leg thigh region should be fixed to the test fixture that secures the leg in place, as shown in Figure 66 below. Despite having the thigh region fixed, the patellofemoral joint must be allowed to flex without issue. This should be repeatable and consistent across trials.



Figure 66: The brace and thigh region of the leg are fixed by clamps, and by a team member placing a force on the quadriceps region to hold the leg down

4. Position the leg at full extension.
5. Click “RUN” on the PiMg software.
6. Over 3 seconds, flex the leg until max flexion is reached.
7. Hold the leg at full flexion for 3 seconds.
8. Over 3 seconds, extend the leg back to full extension.
9. Click “STOP” on the PiMg software.
10. Save the cartesian coordinate data as a .csv file.
11. Check to ensure the data was saved.
12. Repeat each of the 20 unique trials once, so that by the end 40 trials were completed. This ensures an $n=2$.
13. Repeat steps 2 through 12 for each unique trial

Analysis:

The analysis for this test is described in detail in section 7.5 of the report.

Success Criteria for Kinematic Tracking Scanner:

Success for this test will be determined by whether or not our team finds a difference in patellar lift between the experimental trials and the controls.

c. TM-02

The purpose of this test is to gather information about the forces that act on the knee joint. The test method aimed to use a computer software to simulate the forces on the patella. Upon further evaluation, the recommended software did not have a patella, so the test was not able to be completed.

d. TM-03

Test Method-03 Measuring the Dimensions to Fit the Leg

Purpose: The purpose of TM-03 is to evaluate the prototype against DR-03. The importance of this design requirement is that the brace fits the user. The brace needs to be adjustable and fit comfortably around the thigh and the calf.

Materials:

The following materials will be required for this Test Method:

- Tape measure

Procedure (Experimental & Control):

Procedure:

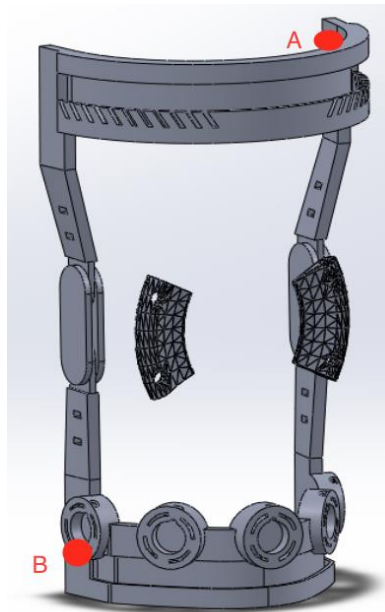

Figure 67: This shows the initial brace structure with points marked to indicate start and end locations on the brace.

1. Start by anchoring the tape measure at point A of Figure 67.
2. Wrap the tape measure around the inside of the brace until it reaches the other side of the brace.
3. Record the length and double it to get an accurate measurement of the thigh as shown in Table 15. Repeat steps 1-3 now anchoring the tape measure at point B pictured in Figure 67.

Table 15: Pass Fail table TM-03

	Measurement	In range?	Pass or Fail?
Thigh		21'' -23.5''	
Calf		16''-18''	

Success Criteria:

The success of this is ensuring that the brace will fit the leg of the user. If the circumference of the thigh is between 21''-23.5'' the brace is successful, if not it fails. If the circumference of the calf is between 16''-18'' the brace is successful, if not it fails.

e. TM-04

TM-04 Range of Motion

Purpose: The purpose of TM-04 is to evaluate the prototype against DR-04. This is required to ensure the user has a normal range of motion when wearing the brace.

Materials:

The following materials will be required for this Test Method:

- Goniometer

Procedure (Experimental & Control):

1. Extend the knee brace completely.
2. Place the center of the goniometer over the center of the hinge.
3. Align the stationary arm with the upper portion of the brace.
4. Move the brace into full flexion and align the moving arm with the lower portion of the brace.
5. Measure and record the flexion angle.

Success Criteria:

The brace achieves 105 degrees of flexion. This is a pass/fail success criteria.

f. TM-05

TM-05 Fatigue Testing

Purpose: the purpose of TM-05 is to evaluate the prototype against DR 05. The importance of this test is to ensure that the brace will not fail under one year of average use.

Materials: The Following materials will be required for this Test Method:

- Prototype of the brace
- Knee Model Fixture
- 2 PVC Pipes (equivalent in diameter of the thigh and calf)
- Motor
- Bar Linkages

Safety Precaution:

Proper Personal Protective Equipment (PPE) should be worn throughout the duration of the procedure. This equipment consists of the following.

- Protective Eyewear

Procedure (Experimental & Control):

Procedure:

1. Attach the respectively sized PVC pipes to the prototype knee brace via the thigh and calf straps already on the brace as seen in Figure 68.
2. Mount the brace and Pipe system to the fixed model “knee”
3. Attach the bar linkages to the PVC pipes
4. Attach the bar linkages to the Motor
5. Run the motor for 2,550,000 cycles, which is equivalent to the average number of steps a person takes per year

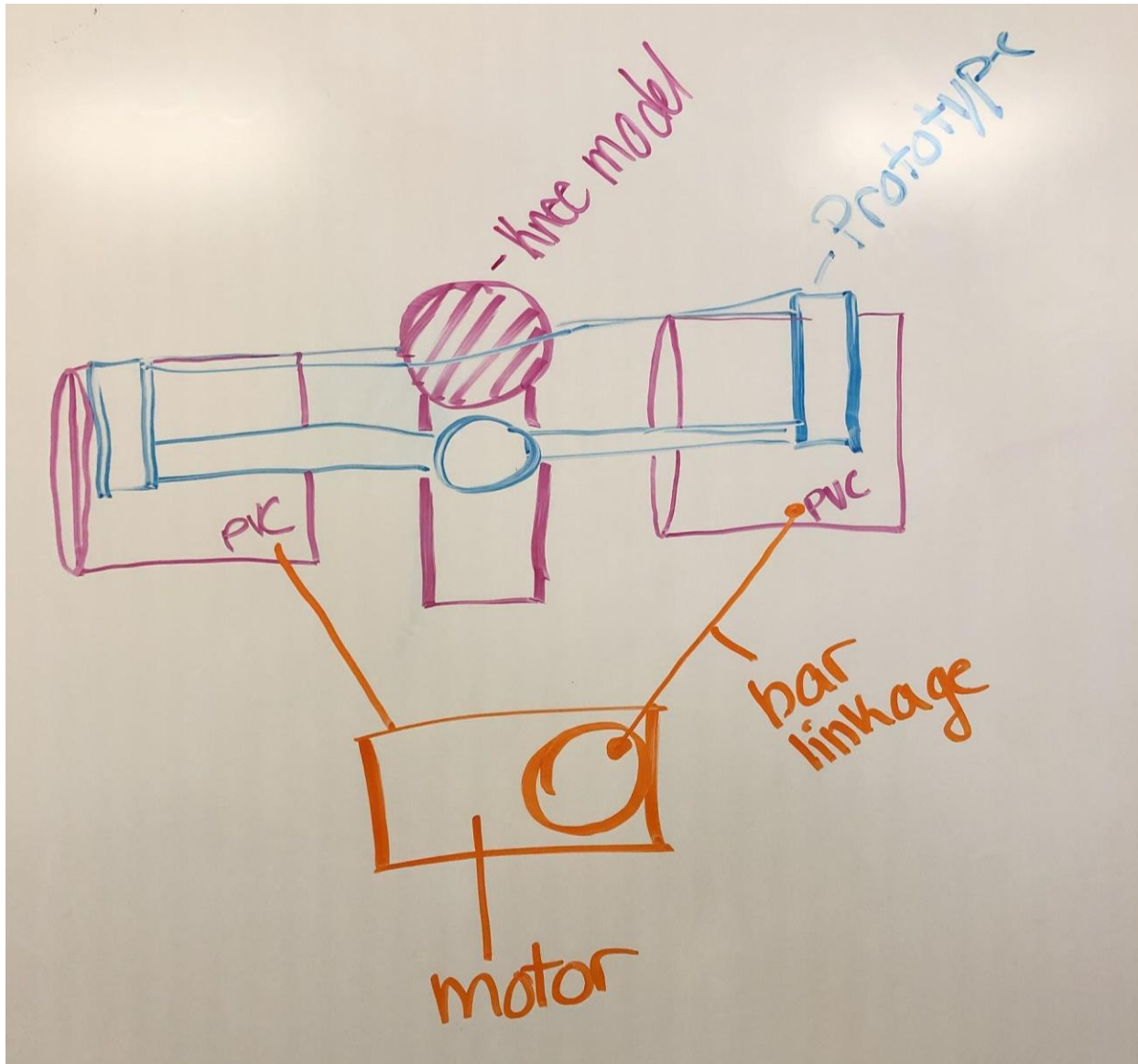

Figure 68: Test Fixture for Fatigue Testing

Success Criteria:

The prototype can be considered to have passed if at the end of the test there are:

- No structural failures
- No signs of fatigue or cracks

g. TM-06

TM-06 Wire Tensile Testing

Purpose: The purpose of TM-06 is to evaluate the prototype against DR-06. The wire to be used in the brace must be capable of surviving mechanical stress without experiencing failure.

Materials:

The following materials will be required for this Test Method:

- Instron 2544
- Wire used for brace
- Tensile grips

Safety Precaution:

Proper Personal Protective Equipment (PPE) should be worn throughout the duration of the procedure. This equipment consists of safety glasses. When testing samples, ensure to place the protective shield in front of the machine during testing.

Hypotheses:

The wire will not fail when burdened by a load of 500N per the wire's specifications.

Procedure (Experimental & Control):

Set the following parameters for the bluehill software:

- Strain rate: .5mm/s,
- Force Upper limit: 500N
- Input: measured gauge length, measured sample diameter
- Output: stress (N/m²), strain, force, and displacement

Once the above requirements have been met:

1. Attach the wire to between the grips of the Instron.
2. Commence tensile test to pull wire from 0 to 500N.

Analysis:

To verify the legitimacy of the results gathered from an experiment, a stress (N) vs strain graph was obtained.

There will only be three wire tested, so the results will not be statistically significant. This limitation is due to the limited financial budget for this project resulting in fewer wires being allocated for this purpose. However, the expected strength of the wire should be several magnitudes above the required strength, producing a large safety factor. This would allow us to be confident in the strength of the wire despite the small number of trials for this test method.

Success Criteria:

The experiment will be considered successful if the wire proves the hypothesis and will be considered unsuccessful if the wire disproves the hypothesis.

h. TM-07

TM-07 Test Method for Human Testing

Purpose:

The purpose of TM-07 is to evaluate the prototype against DR-07. This test method aims to bring comfort to the user of the brace. ASTM F2808, the standard test method for performing behind-the-knee (BTK) tests for evaluating skin irritation, was used as a reference during the creation of this test method.

Materials:

The following materials will be required for this Test Method:

- Brace Prototype

Safety Precaution:

If the user has significant pain at the placement of the brace or at any point of the duration of the test, suspend the test and the user should seek medical attention. Additionally, to ensure consent, it is crucial for all participating members of the client population to understand the test method in its entirety.

Procedure (Experimental & Control):

The user of the brace should have some indications of patellofemoral pain or patellofemoral arthritis. The user should expect to wear shorts so that the brace can come into contact with the skin.

Before both trials the user will be asked the following questions:

1. When was the last time you have experienced patellofemoral pain?
2. What is the consistency of the pain that you experience?
3. On a scale of 1 to 10 rate your pain.
4. Is there a concentration of pain in a specific region of your knee?
 - a. If so, can you indicate it?
5. Is there any chance that you may be pregnant?

Procedure:

1. Have the user wear the brace for 5 hours. The brace will be in direct contact with the skin, not separated by clothing fabrics.
2. Measure and record any dryness or irritation for this time frame.

Control:

1. Have the user put the brace on the knee with no under padding.
2. Have the user wear the brace for 5 hours and the irritation will be measured

After both trials the user will be asked the following questions:

1. Did the brace cause more skin irritation with or without the pre-wrap?
2. Did the brace relieve pain when it was worn?
3. Was there dryness in the contact area of the brace and the knee?
4. Did the brace cause any pain or discomfort?

Answers will be recorded within a team notebook.

Success Criteria:

Little to no irritation as compared to the leg prior to testing.

i. TM-08

TM-08 Test Method - Fujifilm

Purpose: The purpose of TM-08 is to identify the location of and to quantitatively measure the pressure between the patella and the femur. This would help provide evidence that the brace is capable of pulling up on the patella and potentially relieving the pain that is caused by patellofemoral arthritis.

Materials:

- Goat Knee
- Fujifilm Strips x 13
- Instron 5544
- 3-point bending attachments

Safety Precaution:

Wear gloves and PPE. Use disinfectant and proper laboratory practice as necessary.

Procedure (Experimental & Control):

Quantitative measurements:

1. Set up the Instron 5544 for a 3-point bending test.
2. Place a metal plate across the bottom two pins and prepare 10 pieces of Fujifilm.
3. Imprint 100N, 200N, 300N, 400N, 500N, 600N, 700N, 800N, 900N, 1000N onto separate labeled films, by jogging the Instron head down to press into the film with different forces.

Procedure:

1. Prepare FujiFilm and Goat Leg such that the Fujifilm can be inserted underneath the patella
 - a. Seal Fujifilm within a plastic cover prior to being inserted into the knee. This is done by placing a layer of saran wrap on the bottom and top of the Fujifilm and sealing it together with heat.
 - b. Prepare the goat leg by making incisions into the side of the leg which allows for the insertion of the film in between the patella and the femur.

Control:

1. Place Fujifilm underneath the patella at 0 degrees flexion with no brace
2. Flex leg 85 degrees (this is a flexion which is equivalent with descending stairs)
3. Wait 5 seconds
4. Unflex knee and remove Fujifilm
5. Repeat with new Fujifilm film two more times
6. Label the results as control and identify the medial and lateral facets

Test 1:

1. Put brace on the leg
2. Place Fujifilm underneath the patella at 0 degrees flexion

3. Tighten both ratchets equally to the optimal force found in TM-01
4. Flex the leg 85 degrees
5. Wait 5 Seconds
6. Unflex knee and remove Fujifilm. Release the ratcheting mechanism so that there is no tension in the wire
7. Repeat with new Fujifilm until 3 trials have been run in total
8. Label the results as Test 1 and identify the medial and lateral facets

Test 2:

1. Put brace on the leg
2. Place Fujifilm underneath the patella at 0 degrees flexion
3. Tighten the ratchet so that the thigh ratchet is cranked two times more than the calf ratchet
4. Flex the leg 85 degrees
5. Wait 5 Seconds
6. Unflex knee and remove Fujifilm. Release the ratcheting mechanism so that there is no tension in the wire
7. Repeat with new Fujifilm until 3 trials have been run in total
8. Label the results as Test 2 and identify the medial and lateral facets

Test 3:

9. Put brace on the leg
10. Place Fujifilm underneath the patella at 0 degrees flexion
11. Tighten the ratchet so that the calf ratchet is cranked two times more than the thigh ratchet
12. Flex the leg 85 degrees
13. Wait 5 Seconds
14. Unflex knee and remove Fujifilm. Release the ratcheting mechanism so that there is no tension in the wire
15. Repeat with new Fujifilm until 3 trials have been run in total
16. Label the results as Test 3 and identify the medial and lateral facets

Analysis:

The tests will be compared to one another as well as the quantitative film measured from the Instron. Visual inspection should be carried out and tentative values should be assigned to the different films depending on the scale created by the Instron.

Success Criteria:

There are two main tests being conducted with this test.

The test shall be evaluated by the following pass-fail criteria:

- Pass - the brace relieved pressure underneath patella at any flexion
- Fail - there was no noticeable difference in pressure underneath the patella between tests with the brace and without the brace

The test shall also be evaluated by the following quantitative table generated by the quantitative

measurement protocol. The color of the Fujifilm corresponding to certain forces / pressures will be helpful to identify how well, if at all, the brace relieved pressure underneath the patella.

j. TM-09

TM-09 Test Method - Test Clamp Functionality Testing

Purpose: The purpose of TM-09 is to evaluate the effectiveness of each of the c-clamp designs to identify the optimal design for the team's prototype. The evaluation will be accomplished through DR-01 satisfaction testing, user population feedback, finite element analysis, and Fujifilm comparison.

Materials:

- Creo Software
- ANSYS Software
- All c-clamp designs
- CT scanner
- Goat leg

Safety Precaution: The CT scanner utilizes a small amount of radiation to produce cross sectional images of subcutaneous regions of the human body. As such, users will be exposed to a slight amount of radiation. Additionally, to ensure consent, it is crucial for all participating members of the user population to understand the test method in its entirety.

Procedure (Experimental & Control):

User Population Feedback

1. Invite users, or individuals with patellofemoral arthritis, to participate in this section of the test method. The purpose and procedure should be provided so that no aspect of the test method should be left to question.
2. Once consent is received, ask users to wear the brace with the c-clamp design in question attached on the brace.
3. Ask users to turn the ratchet until the ratchet is securely tightened around the knee.
4. Ask user to perform a series of actions, such as walking, jogging, walking upstairs, walking downstairs, sitting down and standing up.
5. Asked the following questions while the patients are wearing the brace:
 - a. Is it comfortable to wear in each action? If not, which actions were uncomfortable? Could you rank them from least to most comfortable?
 - b. Did the c-clamp feel like it remained fixed to your knee in each action? If not, which actions moved the c-clamps out of place? How often did this happen for each action?
 - c. Is there anything in particular that stood out to you about this c-clamp in particular?
6. Repeat the above steps until each c-clamp has been tested and evaluated. Afterwards, ask the user the following questions:

- a. Which c-clamp performed best in your opinion, and what influenced your opinion? What qualities did this c-clamp have that made the difference?
7. Record all answers in Table 16.

Table 16: Results Matrix for TM-09

C-clamp	Question 5a	Question 5b	Question 5c
Hard clamp			
Soft clamp			
Final Question Response			

Success Criteria:

The test will be successful if one particular c-clamp has a higher ranking. An example of a test ranking is shown in Table 17. If clamps are too similar to rank, then there is no obvious superior clamp. Therefore, the test fails.

Table 17: Example Ranking Matrix

Clamp Type	User preference	Forces applied from film	Final ranking
Type A	Most preferred	40N	1
Type B	Least preferred	30N	2

IV. Testing Results
a. Tensile Wire Test
Wire 1:

Table 18: Wire 1 Data

Break (Standard) : Extension at Break (Standard)	1.37083	mm
Break (Standard) : Load at Break (Standard)	59.05031	kgf
Break (Standard) : Tensile extension at Break (Standard)	1.37083	mm
Break (Standard) : Tensile strain (Extension) at Break (Standard)	0.01896	mm/mm
Break (Standard) : Time at Break (Standard)	8.222	s
Break (Standard) : Tensile stress at Break (Standard)	0.00006	kgf/mm ²
Area under curve : Area under curve	0	J
Area under curve : Status number at Area under curve	1	
Break (Standard) : Data point at Break (Standard)	115	
Specimen properties : Final length	100	mm
Specimen properties : Length	72.3	mm
Strain : Tensile strain (Extension) gauge length	72.3	mm
Yield (Zero slope) : Data point at Yield (Zero slope)	114	
Yield (Zero slope) : Energy at Yield (Zero slope)	0.43209	J
Yield (Zero slope) : Extension at Yield (Zero slope)	1.36479	mm
Yield (Zero slope) : Load at Yield (Zero slope)	59.56104	kgf
Yield (Zero slope) : Status number at Yield (Zero slope)	1	
Yield (Zero slope) : Tenacity at Yield (Zero slope)	5.84094	N/tex
Yield (Zero slope) : Tensile extension at Yield (Zero slope)	1.36479	mm
Yield (Zero slope) : Tensile strain (Extension) at Yield (Zero slope)	0.01888	mm/mm
Yield (Zero slope) : Time at Yield (Zero slope)	8.186	s

Yield (Zero slope) : Tensile stress at Yield (Zero slope)

0.00006

kgf/mm²

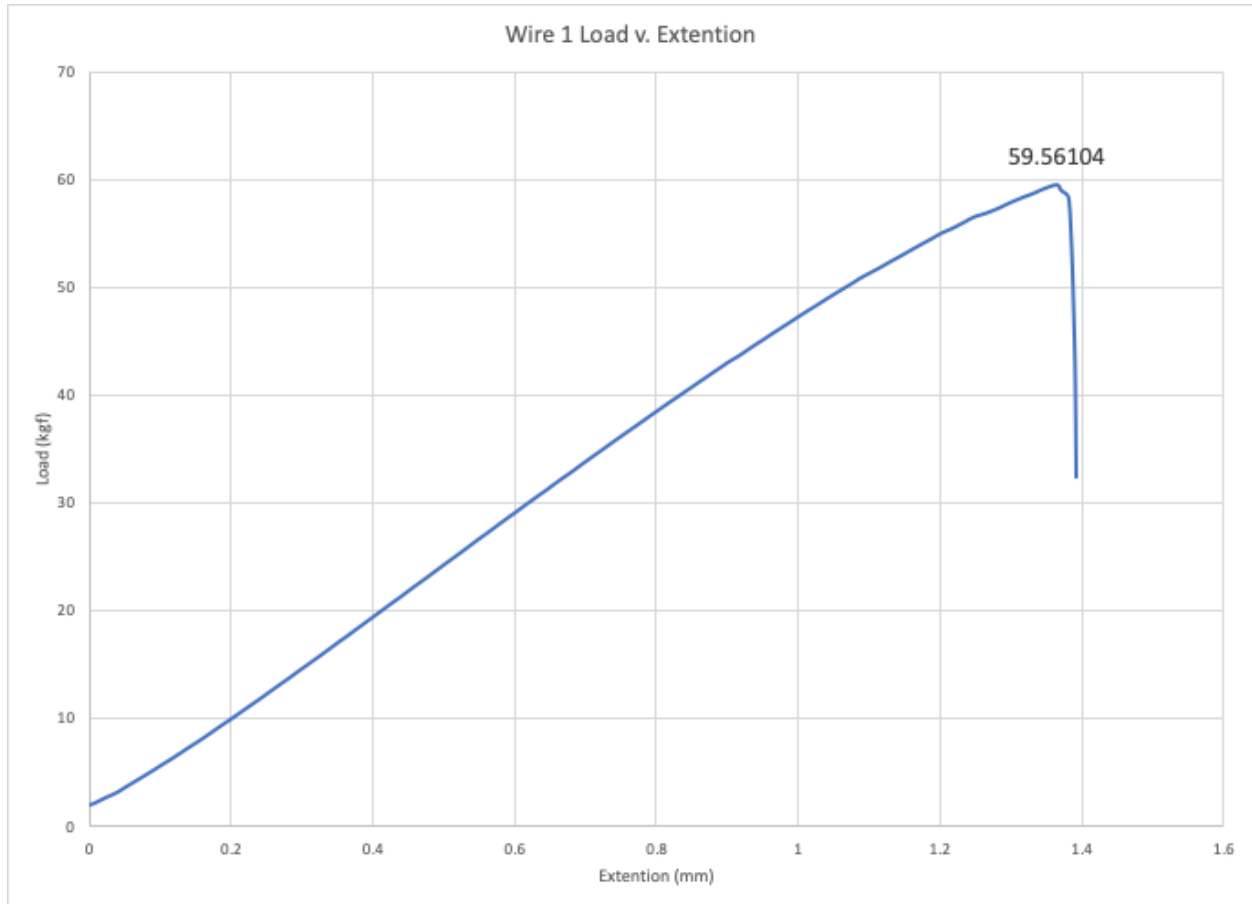

Figure 69: Wire 1 graph

Wire 2:

Table 19: Wire 2 Data

Extension at Break (Standard)	1.99542	mm
Load at Break (Standard)	50.09124	kgf
Tensile extension at Break (Standard)	1.99542	mm
Tensile strain (Extension) at Break (Standard)	0.01882	mm/mm
Time at Break (Standard)	11.972	s
Tensile stress at Break (Standard)	0.00005	kgf/mm ²
Area under curve	0	J
Status number at Area under curve	1	
Data point at Break (Standard)	131	
Final length	100	mm
Length	106	mm
Tensile strain (Extension) gauge length	106	mm
Data point at Yield (Zero slope)	123	
Energy at Yield (Zero slope)	0.60855	J
Extension at Yield (Zero slope)	1.88646	mm
Load at Yield (Zero slope)	51.72346	kgf
Status number at Yield (Zero slope)	1	
Tenacity at Yield (Zero slope)	5.07234	N/tex
Tensile extension at Yield (Zero slope)	1.88646	mm
Tensile strain (Extension) at Yield (Zero slope)	0.0178	mm/mm
Time at Yield (Zero slope)	11.318	s
Tensile stress at Yield (Zero slope)	0.00005	kgf/mm ²

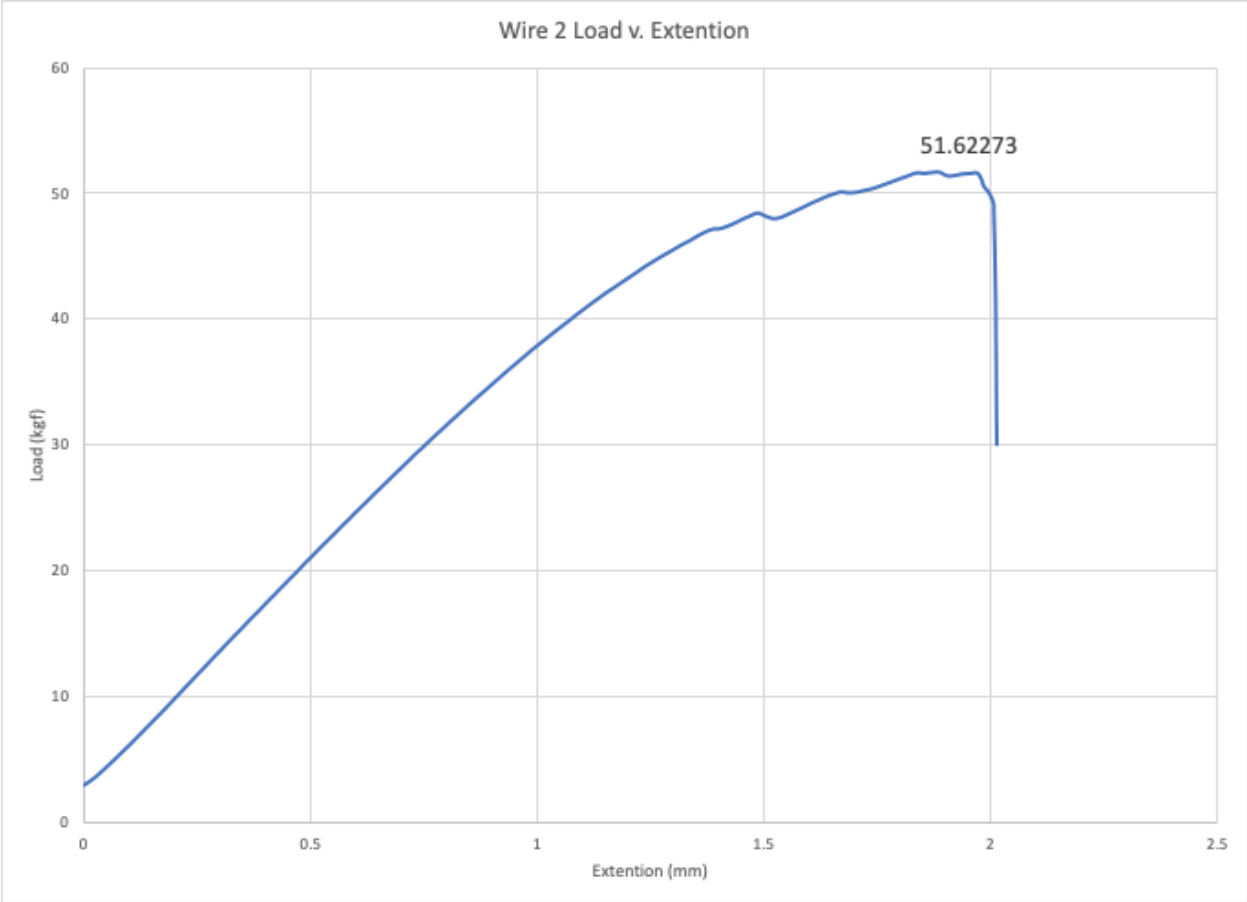

Figure 70: Wire 2 graph

Wire 3:

Table 20: Wire 3 Data

Extension at Break (Standard)	2.48021	mm
Load at Break (Standard)	65.27577	kgf
Tensile extension at Break (Standard)	2.48021	mm
Tensile strain (Extension) at Break (Standard)	0.02708	mm/mm
Time at Break (Standard)	14.88	s
Tensile stress at Break (Standard)	0.00007	kgf/mm ²
Area under curve	0	J
Status number at Area under curve	1	
Data point at Break (Standard)	166	
Final length	100	mm
Length	91.6	mm
Tensile strain (Extension) gauge length	91.6	mm
Data point at Yield (Zero slope)	166	
Energy at Yield (Zero slope)	0.65823	J
Extension at Yield (Zero slope)	2.48021	mm
Load at Yield (Zero slope)	65.27577	kgf
Status number at Yield (Zero slope)	1	
Tenacity at Yield (Zero slope)	6.40137	N/tex
Tensile extension at Yield (Zero slope)	2.48021	mm
Tensile strain (Extension) at Yield (Zero slope)	0.02708	mm/mm
Time at Yield (Zero slope)	14.88	s
Tensile stress at Yield (Zero slope)	0.00007	kgf/mm ²

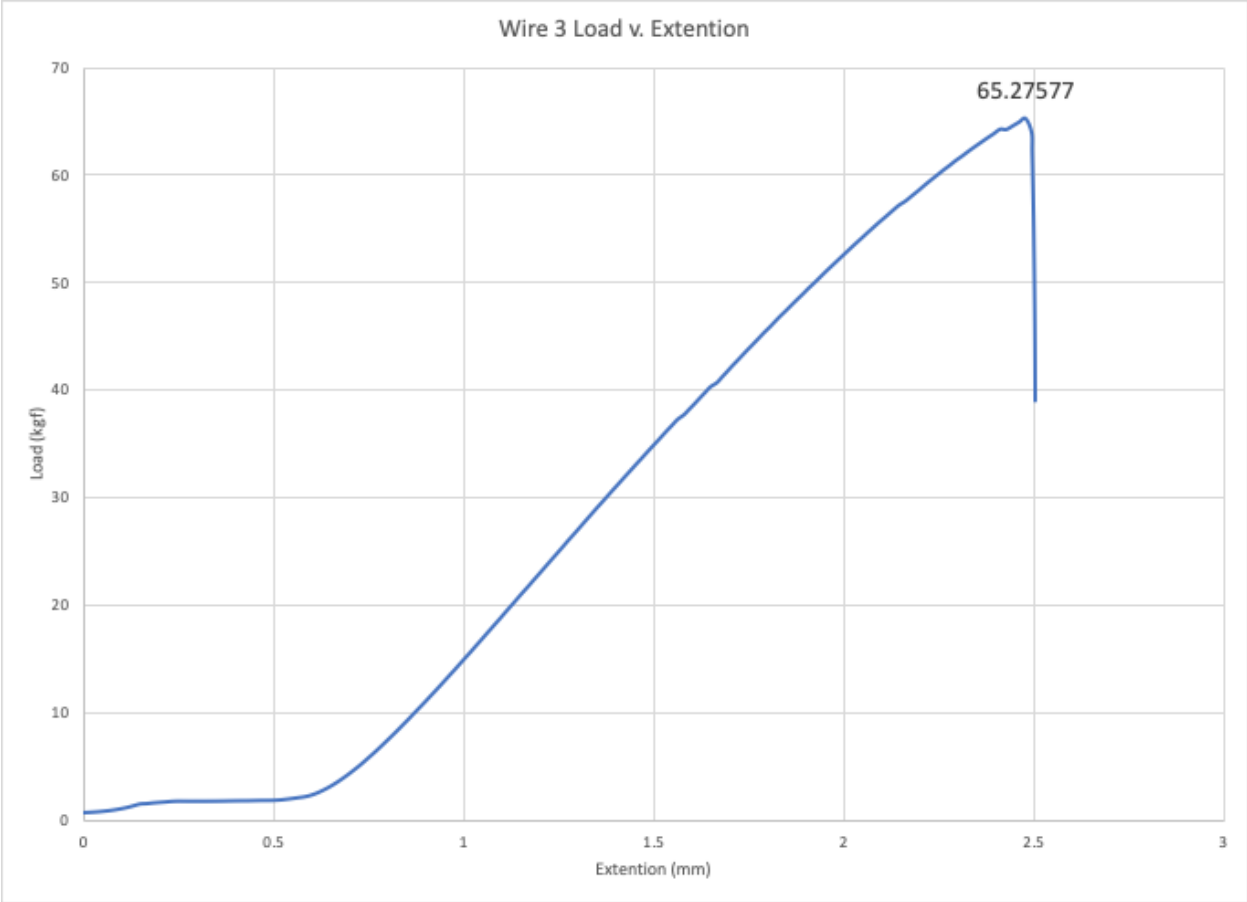

Figure 71: Wire 3 graph

b. CT Test
Scanning information, during the completion of the test:

Table 21: CT Scan Information

Image #	Anchor Orientation	Clamp Type	Wire Crossing	Ratchet	Scan #	Resulting image (good or bad)?	Notes
1	control	control	control	control	4166	good image (xy shows shifted to left)	Negative Control Scan (just leg)
2	control	control	control	control	4167	good image (xy shows shifted to right)	Positive Control Scan (brace + leg) Scanning in stacks of 9mm, the length of image 110mm -> 79mm
3	across	hard	cross below	0	4168	good image (no good data)	We lost a lot of the patella on the scout view due to the bone being offset in the brace. it was moved more flush to try and fit more in the image
4	across	hard	cross below	1 (90 deg)	4169	good image (no good data)	We packed the underside of the patella so that it was in contact with the brace. The upper and lower components were touching
5	across	hard	cross below	2 (90 deg)	4170	good image (no good data) (patella shifted right)	Each ratchet was rotated 45 degrees for further activation. Lower half of c-clamp (longways) in contact with patella, but upper half of c-clamp did not appeared in contact with the patella. Success with the cross below in wire crossing category seems doubtful. [ML]
6	same side	hard	both	0	4171	good image (1/2 good data)	The patella is not in the center of the brace due to the improper sizing of the leg and constraints of the CT scanner - this impacted the efficacy of the rubber band in holding the c-clamps in place
7	same side	hard	both	1 (90 deg)	4172	good image (no good data)	Having trouble keeping the lateral clamp (right goat leg) stay under the patella (tissue squishy around and the rubber bands are doing very little to keep the clamps down and in place
8	same side	hard	both	2 (90 deg)	4173	good image (no good data)	As we ratcheted, we noticed that the whole leg is shifted medially within the brace (since the leg is smaller) This means although the medial c-clamp looked pushed down at an odd angle, it was closer than the lateral c-clamp which we were having trouble with
9	across	hybrid	cross below	0	4174	great image (1.5/2 good data)	confident about this patella being farther down - modified how we put

							the rubber bands in
10	across	hybrid	cross below	1 (90 deg)	4175	great image (1.5/2 good data)	a little offset maybe 50 degrees offset (where before it was 75 degrees)
11	across	hybrid	cross below	2 (90 deg)	4176	great image (2/2 good data)	realigned the leg to get a better scan (close to 0 offset hopefully)
12	across	hard	cross below	2 (90 deg)	4177	great image (0.5/2 good data)	Retake the images of the hard c-clamp now that we know how to best position the c-clamps on the patella (the images of the hybrid) It was not positioned properly, we assessed and tried to retake the picture with the next scan
13	across	hard	cross below	2 (90 deg)	4178	great image (1.5/2 good data)	The re-retake still looks tilted but good!
14	same side	hard	both	2 (90 deg)	4179	great image (2/2 good data)	

Scan selected:

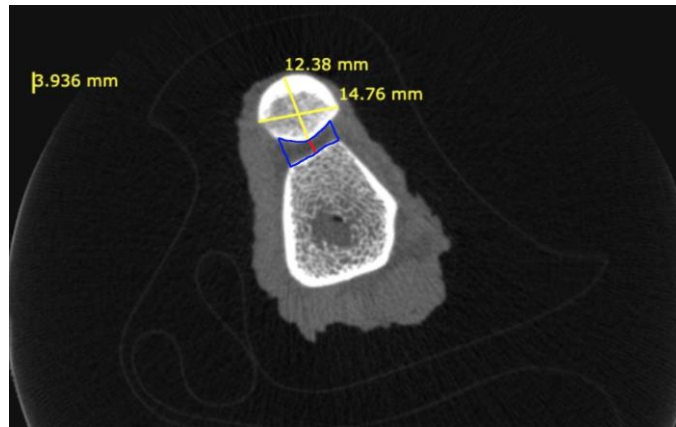

Figure 72: Negative Control

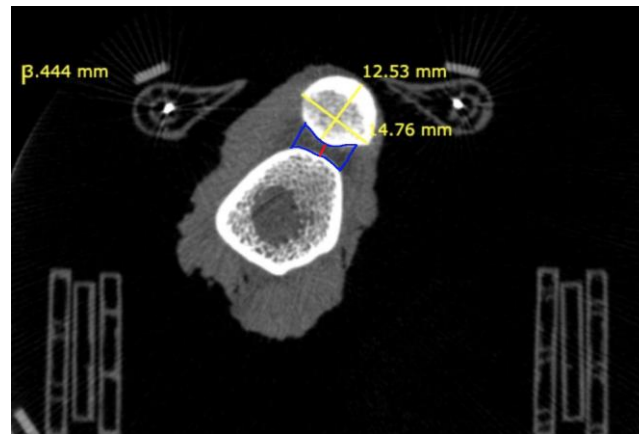

Figure 73: Positive Control

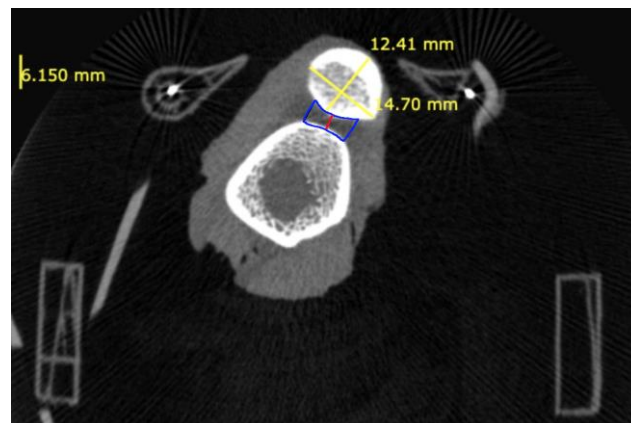

Figure 74: Across Hard 90 Configuration

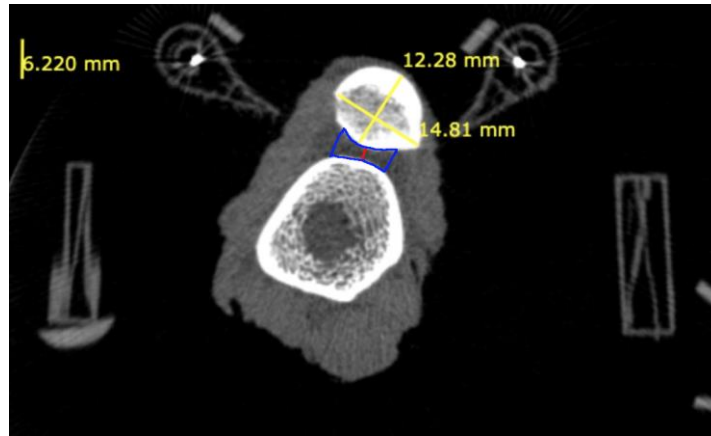

Figure 75: Across Hard 180 Configuration

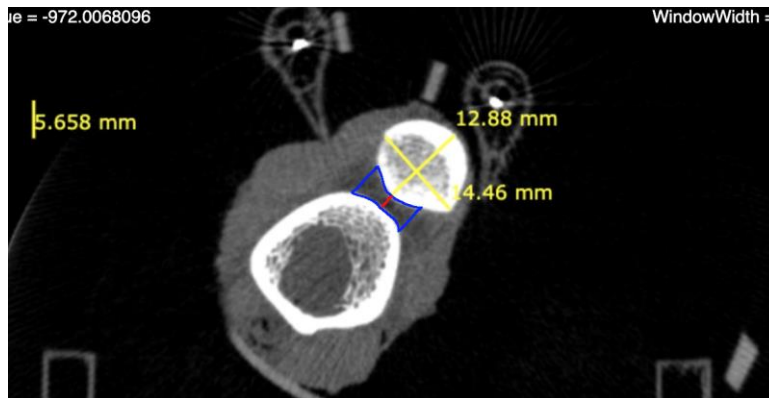

Figure 76: Same Side Hard 0 Configuration

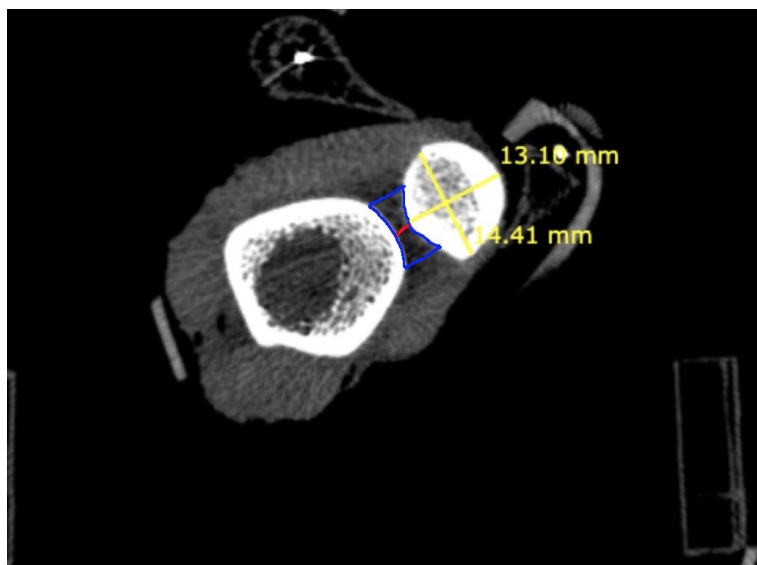

Figure 77: Same Side Hard 90 Configuration

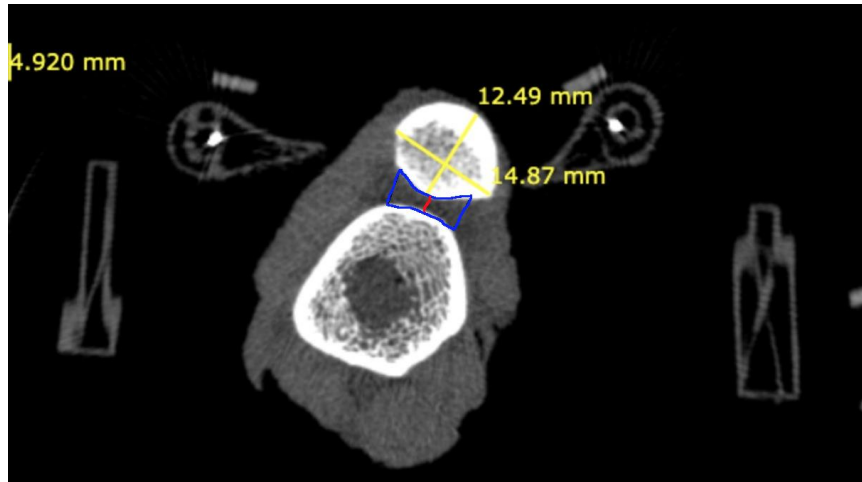

Figure 78: Same Side 180 Configuration

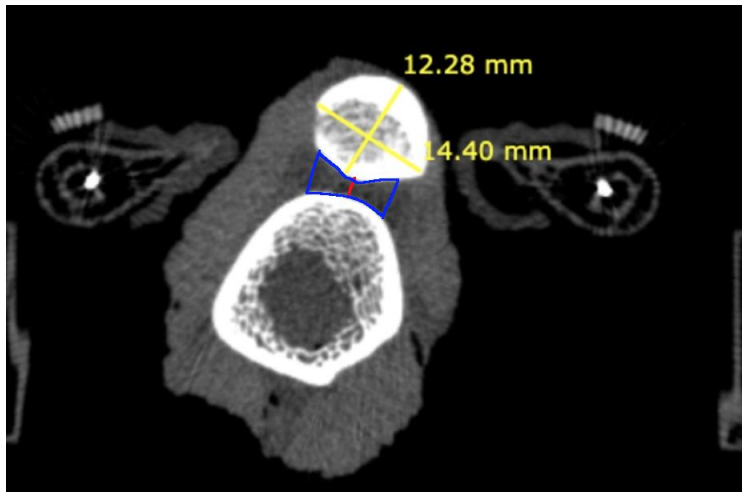

Figure 79: Across Hybrid 0 Configuration

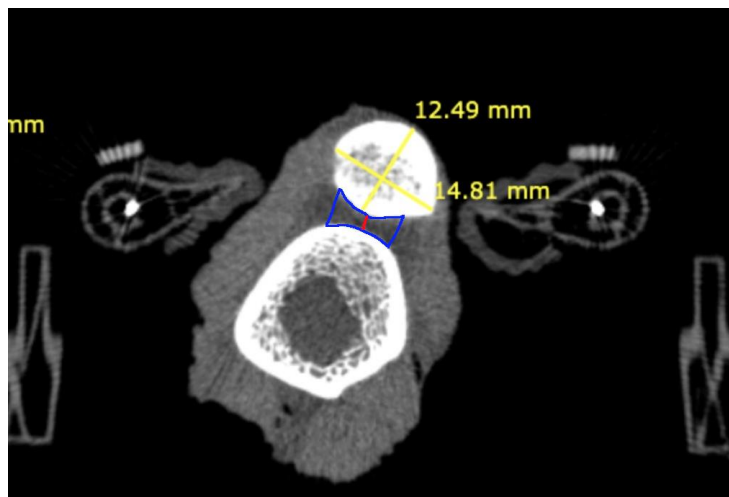

Figure 80: Across Hybrid 90 Configuration

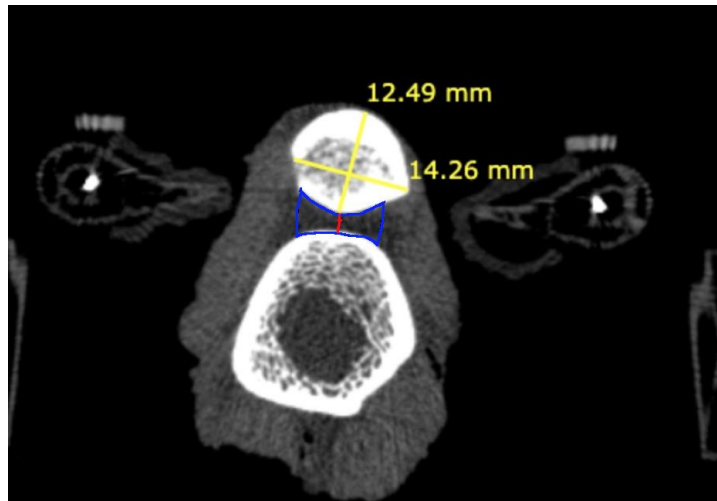

Figure 81: Across Hybrid 180 Configuration

Across hard analyzed

Table 22: Across Hard Data

	lb	MP	RB	area
negative control	0.495	0.213	0.375	34.627
positive control	0.469	0.188	0.512	32.11
Across Hard 0	0.486	0.265	0.478	32.656
Across Hard 90	0.393	0.265	0.435	27.315
Across Hard 180	0.461	0.196	0.375	24.695

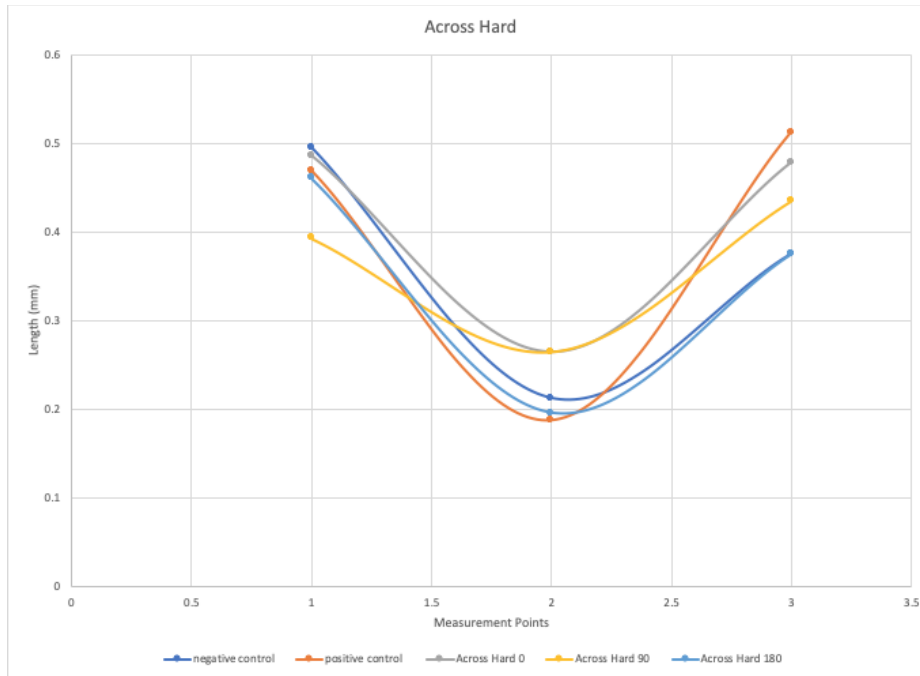

Figure 82: Across Hard Configuration Compared to Controls

Same Side Hard analysis

Table 23: Same Side Hard Data

	LB	MP	RB	area
negative control	0.495	0.213	0.375	34.627
positive control	0.469	0.188	0.512	32.11
Same Side Hard 0	0.503	0.213	0.469	29.559
Same Side Hard 90	0.452	0.196	0.469	28.289
Same Side Hard 180	0.444	0.205	0.469	28.927

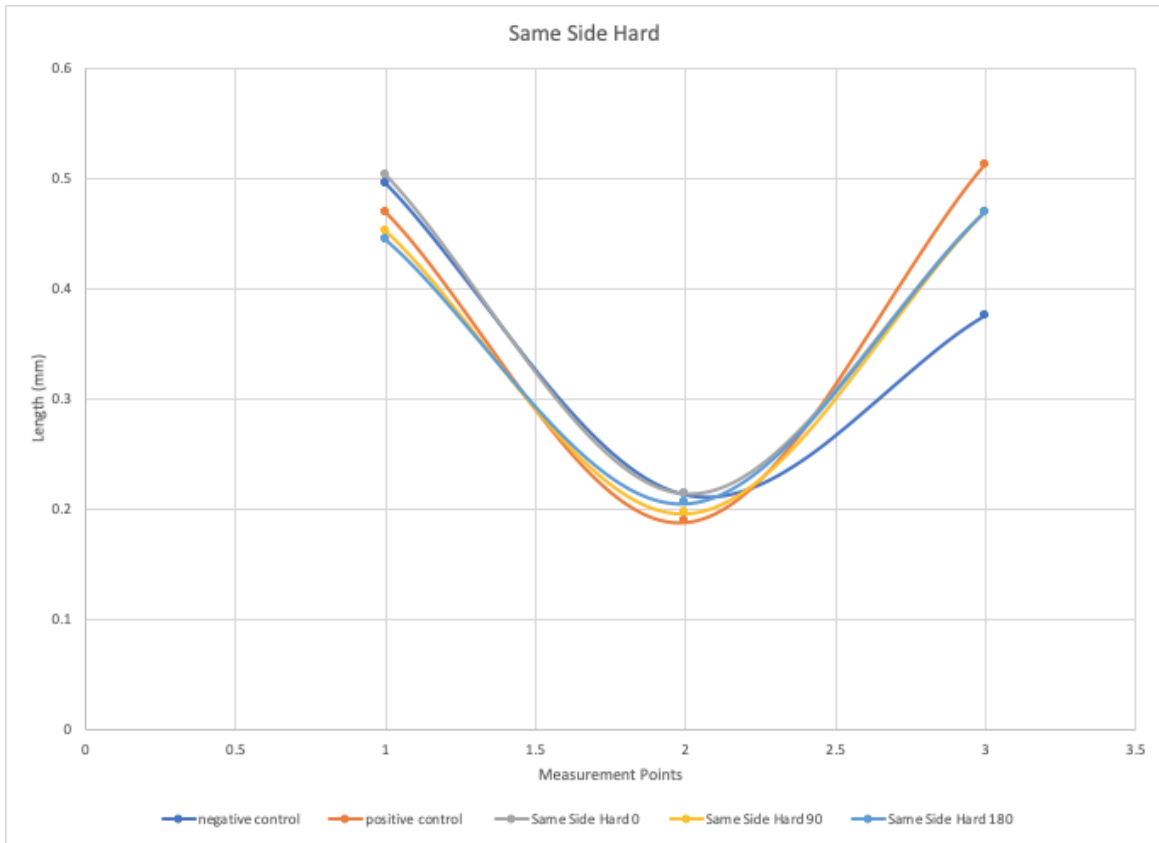

Figure 83: Same Side Hard Configuration Compared to Controls

Across Hybrid Analyzed

Table 24: Across Hybrid Data

	LB	MP	RB	area
negative control	0.495	0.213	0.375	34.627
positive control	0.469	0.188	0.512	32.11
Across hybrid 0	0.486	0.213	0.452	29.866
Across Hybrid 90	0.461	0.188	0.427	25.147
Across hybrid 180	0.538	0.205	0.486	29.431

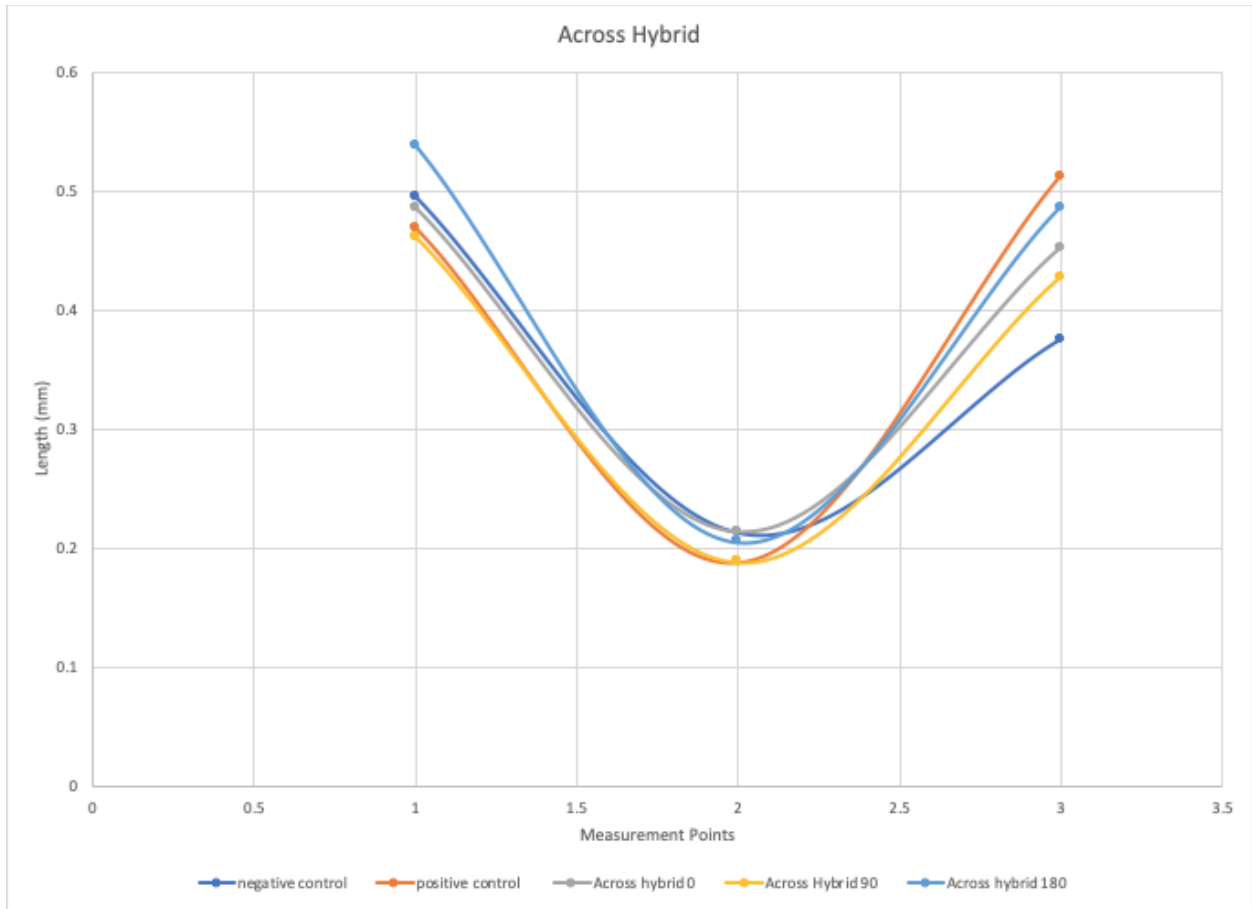

Figure 84: Across Hybrid Configuration Compared to Controls

All Data Compared

Table 25: All Data Compared

	LB	MP	RB	area
Negative control	0.495	0.213	0.375	34.627
Positive control	0.469	0.188	0.512	32.11
Across Hard 0	0.486	0.265	0.478	32.656
Across Hard 90	0.393	0.265	0.435	27.315
Across Hard 180	0.461	0.196	0.375	24.695
Same Side Hard 0	0.503	0.213	0.469	29.559
Same Side Hard 90	0.452	0.196	0.469	28.289

Same Side Hard 180	0.444	0.205	0.469	28.927
Across Hybrid 0	0.486	0.213	0.452	29.866
Across Hybrid 90	0.461	0.188	0.427	25.147
Across hybrid 180	0.538	0.205	0.486	29.431

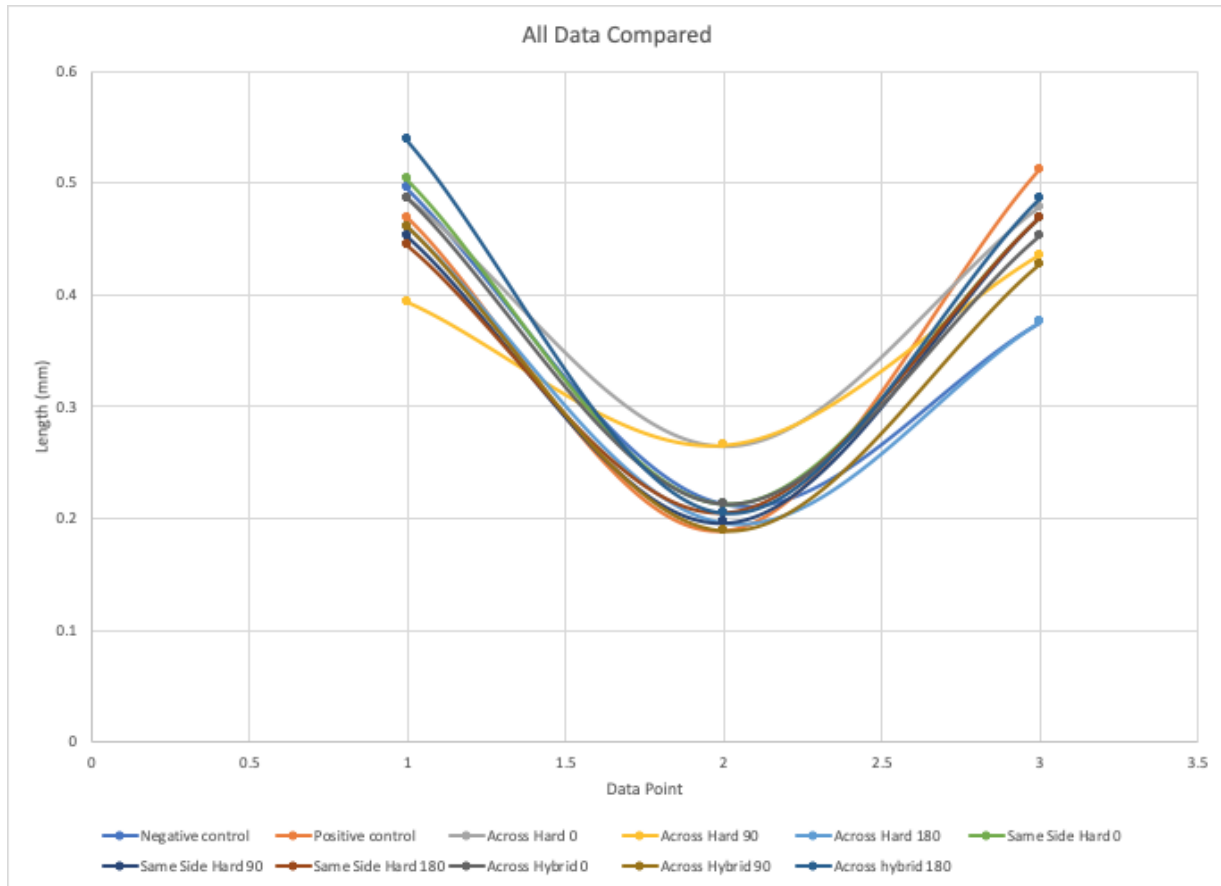

Figure 85: All Data Compared

c. Kinematic Tracking Test

Due to the large nature of the results files from this test method, they are not included directly within this report. However, the raw data and sheets used for analysis can be found using this link:

<https://drive.google.com/drive/folders/1J422hGBmFNCvH4ShEYcQ5kF-o9ljcYxA?usp=sharing>

If the link is broken or no longer works, please contact Dr. Ambady or Dr. Sabuncu at sambady@wpi.edu and acsabuncu@wpi.edu respectively.

d. C-clamp

- Ask user to perform a series of actions, such as walking, jogging, walking upstairs, walking downstairs, sitting down and standing up.

- Asked the following questions while the patients are wearing the brace:
 - Is it comfortable to wear in each action? If not, which actions were uncomfortable? Could you rank them from least to most comfortable?
 - Did the c-clamp feel like it remained fixed to your knee in each action? If not, which actions moved the c-clamps out of place? How often did this happen for each action?
 - Is there anything in particular that stood out to you about this c-clamp in particular?
- Repeat the above steps until each c-clamp has been tested and evaluated. Afterwards, ask the user the following questions:
 - Which c-clamp performed best in your opinion, and what influenced your opinion? What qualities did this c-clamp have that made the difference?

Test Subject #1

Table 26: C-clamp Analysis 1

C-clamp	Question 5a	Question 5b	Question 5c
Hard clamp	All were comfortable, the brace slides off more when squatting or standing up	They wedged well while the knee was bent, but would “unwedge” when leg was straight	Felt secure in the brace, reminds me of the j-braces I used to wear, I can really feel the wedge when it was engaged correctly
Soft clamp	All were comfortable	This stayed wedged more consistently	As much as it stayed engaged through all actions, I preferred the feel of the hard clamp
Final Question Response	Preferred the hard clamp, the feel just worked better for comfort around the knee, would love to see a design update so it stayed engaged for through full flexion of the leg		

Test Subject #2

Table 27: C-clamp Analysis 2

C-clamp	Question 5a	Question 5b	Question 5c
Hard clamp	All was comfortable, moved a lot when sitting down or standing up	Felt great when leg was bent, it was engaged, but it would lose some wedge	I liked how well it wedged when it was engaged, I could clearly feel it interact

		when leg was straightened, might be because my knees hyperextend	with my knee as I was wearing it
Soft clamp	All were comfortable	Fit well, did not move throughout flexion	Harder to place around my knee versus the wedge from the hard clamp
Final Question Response	Preferred the hard clamp, it wedged under my patella whereas the soft felt like it interacted with the skin more than the joint.		

e. Human Feedback

Test Subject #1

Before both trials the user will be asked the following questions:

1. When was the last time you have experienced patellofemoral pain?

About 1 week ago

2. What is the consistency of the pain that you experience?

Generally, it is limited to when I am doing activity, but I feel it when I walk.

3. On a scale of 0 to 10 rate your pain.

1

Figure 1: Pain Chart

4. Is there a concentration of pain in a specific region of your knee?

yes

a. If so, can you indicate where?

Right under the kneecap towards the tibia

5. Is there any chance that you may be pregnant?

No

Procedure:

1. Have the user wear the brace for 5 hours. The brace will be in direct contact with the skin, not separated by clothing fabrics.
2. Measure and record any dryness or irritation for this time frame.

Control:

1. Have the user put the brace on the knee with no under padding.
2. Have the user wear the brace for 5 hours and the irritation will be measured

After the trial the user will be asked the following questions:

1. Did the brace relieve pain when it was worn?

yes

- a. On a scale of 0 to 10 rate your pain using the same pain chart as in Figure 1.0

2. Was there dryness in the contact area of the brace and the knee?

No

3. Did the brace cause any pain or discomfort?

The wires from the brace dug into the skin, otherwise it was comfortable

Answers will be recorded within a team notebook.

Success Criteria:

Little to no irritation as compared to the leg prior to testing.

Test Subject #2

Before both trials the user will be asked the following questions:

1. When was the last time you have experienced patellofemoral pain?
 1. A few weeks ago
2. What is the consistency of the pain that you experience?

1. If doing athletics: skiing/squats/lunges then pretty frequently, but outside more rare
3. On a scale of 0 to 10 rate your pain.

Figure 1: Pain Chart

- 0
4. Is there a concentration of pain in a specific region of your knee?
 1. Usually right underneath the kneecap and on the outer edge of the kneecap
- b. If so, can you indicate where?
5. Is there any chance that you may be pregnant?
 1. no

Procedure:

1. Have the user wear the brace for 5 hours. The brace will be in direct contact with the skin, not separated by clothing fabrics.
2. Measure and record any dryness or irritation for this time frame.

Control:

1. Have the user put the brace on the knee with no under padding.
2. Have the user wear the brace for 5 hours and the irritation will be measured

After the trial the user will be asked the following questions:

1. Did the brace relieve pain when it was worn?
 1. I could see it relieving pain and I can feel it pinching the kneecap
- b. On a scale of 0 to 10 rate your pain using the same pain chart as in Figure 1.
 1. 0
 2. Was there dryness in the contact area of the brace and the knee?
 3. Did the brace cause any pain or discomfort?

Answers will be recorded within a team notebook.

Success Criteria:

Little to no irritation as compared to the leg prior to testing.

Other notes:

1. C-Clamps does not stay in place when bending
2. Slipping down leg (leg smaller than bris)
3. Back of strap on thigh is abrasion
4. The thickness of the brace hinders normal gait(leg swings out to avoid chaffing)
5. The brace is not uncomfortable, and user is excited
6. When take brace off knee feels better, easier to walk, feels more “loose” (good in her opinion” like more lubed up?
7. Soft clamp does not feel as “wedgy” not as stabilizing as the hard clamp *but* it moves with the movement of the patella through gait better than the hard clamp

f. General Systems

Table 28: General Systems Data

Trial	Force (lbs)
0	0.00
1	0.50
2	0.75
3	1.25
4	2.25
5	3.00
6	3.75
7	4.50