

300W DC to DC Converter for Use in AC Inverters

A Major Qualifying Project Report:

Submitted to

WORCESTER POLYTECHNIC INSTITUTE

As a requirement for the

Degree of Bachelor of Science by:

Seth Crocker

Nathan Roux

Submitted on 08/01/2011

Approved By:

Prof. Stephen J. Bitar

Abstract

The purpose of this project was to create a high voltage DC-DC converter for use in inverter applications. Extensive background research was conducted to evaluate existing inverter device functionality. Multiple prototypes were constructed to characterize losses and investigate ways to maximize efficiency. Testing of the final prototype included load testing, thermal characterization, efficiency evaluation, and noise level capture, with mixed results. Further work is required to provide closed loop control, safety shut off and low battery warnings.

Acknowledgements

We would like to thank the following people and parties for helping us with our project.

Our thanks first go out to the company Waste to Watts who came up with the problem of which hopefully our project will be the solution. We wish the best of luck to them in their business, and hope that it takes root and they make a great difference in the lives of the people in countries who are not fortunate to have such a stable power infrastructure as we do here in the states.

Secondly we would like to thank our project advisor Professor Stephen Bitar, for overseeing our project from the initial research to this paper. His time and effort as well as his advice and guidance undoubtedly were the driving force behind our project.

Lastly we would like to thank the ECE department and WPI as a whole for our education and help with understanding our material without which we would not possess the tools required for the completion of this project.

Table of Contents

Abstract.....	i
Acknowledgements.....	ii
Table of Figures.....	v
Table of Tables	vi
Table of Equations	vi
1 Introduction to Waste to Watts.....	1
1.1 Our interaction with Waste to Watts.....	1
2 Introduction	2
2.1 Introduction to DC-DC Converters	2
2.2 Types of DC-DC Converters	2
2.3 Research Space/ Goals.....	8
2.4 Purpose of Circuit.....	8
2.5 Prior Art.....	8
2.6 Real World Parts	13
2.7 Safety Standards	13
3 The DC-DC Converter Type We Chose	17
3.1 Advantages and Disadvantages with Our Possible Choices.....	17
3.2 Our final decision	18
4 System Level Design.....	19
4.1 How it works (Block Diagram Level/ qualitative explanation).....	19
4.2 Control Chips compatible with our design.....	21
4.3 Detailed Front End and Transformer Bias Design.....	23
4.4 Detailed Switch Control Design.....	24
4.5 Transformer and Output Filtering Design	25
5 Simulations.....	26
5.1 Spice Models	26
5.2 Basic Realistic Transformer Model.....	26
5.3 DC-DC Boost Converter Model	27
5.4 Two-Stage DC-DC Converter	29

5.5	V2.2 Prototype primary side	30
6	Testing/results	33
6.1	Potential Components	33
6.2	V0	34
6.3	V2	38
6.4	V2.1	42
6.5	V2.2	45
6.6	Coil testing	48
7	Future Work/Improvements.....	51
7.1	Safety	51
7.2	Efficiency	51
7.3	Additional Functionality	52
7.4	Conclusion.....	53
8	Conclusion.....	54
9	Appendix A.....	55
10	Appendix B: Waste to Watts.....	57
10.1	Company Overview*	57
10.2	Business Description and Vision	58
10.3	Product Description- Enzi.....	59
11	References	61

Table of Figures

Figure 1: Basic boost converter schematic diagram	2
Figure 2: Buck boost converter schematic diagram.....	4
Figure 3: Ćuk converter schematic diagram	5
Figure 4: SEPIC converter schematic diagram	6
Figure 5: Flyback Converter Schematic Diagram	6
Figure 6: Half Bridge Converter Schematic Diagram	7
Figure 7: Inverter waveform types[2]	9
Figure 8: The PV375 power inverter from Triplite.....	12
Figure 9: NEMA 5-15R diagram[5]	15
Figure 10: Typical efficiency graphs for a DC-DC boost converter[3]	17
Figure 11: System Block Diagram.....	19
Figure 12: Front End and Transformer Bias Block Schematic Diagram.....	20
Figure 13: Switch Control Block Schematic Diagram	20
Figure 14: Transformer and Output Filtering Schematic Diagram.....	21
Figure 15: Our custom transformer coil	25
Figure 16: Schematic Diagram of the Transformer Model	27
Figure 17: Schematic Diagram of the Boost Converter Model	28
Figure 18: Basic DC-DC boost converter model result.....	28
Figure 19: Schematic Diagram of the Two Stage Boost Converter Model	30
Figure 20: Two stage DC-DC boost converter model result.....	30
Figure 21: Parasitic circuit elements causing large voltage overshoots	31
Figure 22: The result of adding a small capacitor to fix the losses from parasitic inductance.....	32
Figure 23: V0 prototype schematic.....	35
Figure 24: Picture of the V0 prototype	36
Figure 25: MOSFET Gates and Drains post Hex inveter	37
Figure 26: MOSFET gates post hex inverter.....	37
Figure 27: MOSFET gates with hex inverter.....	37
Figure 28: xformer output before bridge post hex inverter	38
Figure 29: V2 prototype schematic diagram.....	38
Figure 30: MOSFET drains V2.....	41
Figure 31: MOSFET gates V2	42
Figure 32: V2.1 Schematic Diagram	43
Figure 33: MOSFET Drains V2.1	44
Figure 34: MOSFET gates V2.1	45
Figure 35: Picture of the V2.2 prototype	46
Figure 36: V2.2 MOSFET gates signal.....	47
Figure 37: V2.2 MOSFET drains voltage characteristic	47
Figure 38: Original Coil's Frequency Response	49
Figure 39: Rewound Coil's Frequency Response	49
Figure 40: Traced schematic from the Triplite PV375 power inverter (DC DC boost converter half)	56

Figure 41: Waste to Watts Kellogg Foundation Logic Model 58

Figure 42: a) Grid power used to charge battery and run the attached device; b) Grid power interruption causes Enzi to go into battery backup mode, where battery power is used to run the attached device.. 60

Figure 43: (Left) Picture of 3rd Generation Prototype, (Right) Enzi Functional Block Diagram 60

Table of Tables

Table 1: Prior Art Compare 11

Table 2: Coil Testing 48

Table 3: Old Coil Data..... 55

Table 4: Rewound Coil Data 55

Table of Equations

Equation 1: Current, voltage, inductance, & time relation of a DC-DC boost converter closed switch condition 3

Equation 2: Equation 1 rearranged to solve for current change in time 3

Equation 3: Current, voltage, inductance, & time relation of a DC-DC boost converter open switch condition 3

Equation 4: Open & closed circuit conditions averaged for one period..... 3

Equation 5: Output voltage equation for a DC DC boost converter 3

Equation 6: Calculating minimum required inductance for a DC-DC boost converter..... 3

Equation 7: Calculating output ripple for a DC-DC boost converter..... 3

Equation 8: Calculating output voltage of a Buck-Boost converter..... 4

Equation 9: Calculating minimum inductance required for a Buck-Boost converter 4

Equation 10: Calculating output voltage ripple for a Ćuk converter 5

Equation 11: Calculating minimum required inductance for L1 for the Ćuk converter 5

Equation 12: Calculating minimum required inductance for L2 for the Ćuk converter 5

Equation 13: Calculating output voltage of the SEPIC converter 6

Equation 14: Calculating output voltage ripple for the SEPIC converter..... 6

Equation 15: Calculating minimum capacitance required for circuit operation of a SEPIC converter..... 6

Equation 16: Calculating output voltage of a Flyback converter 7

Equation 17: Calculating minimum transformer magnetizing inductance for a Flyback converter..... 7

Equation 18: Calculating output voltage of a Half Bridge converter 7

Equation 19: Ohm's law basic equations 23

Equation 20: Capacitor discharge equation, the equation solved for time, and the equation solved for capacitance 23

1 Introduction to Waste to Watts

This section describes our interaction with the company that is responsible for funding this project. This company is called Waste to Watts and as a company it has a unique business plan. What makes it special is its built in effort to reduce the proliferation of electronic waste in third world countries, as well as its conscious decision as part of its plan is to help alleviate the problem of constant power failures for a better quality of life. More information on Waste to Watts please see Appendix B.

1.1 Our interaction with Waste to Watts

Our interaction with Waste to Watts occurred mostly at the beginning and end of our project, and not so much in the middle. It consisted mostly of pairing up our ideas for the project with what they had in mind for the project.

In the beginning of our project our advisor was a go between, between us and W2W. This was the time were trying to decide what the requirements for the project should be. Requirements such as output wattage, potential form factor, potential weight, cost considerations, etc. was taken into consideration. The weekly meetings with our advisor and W2W helped define the requirements for our project.

Towards the end of our project we not only got more help on our design but received more data from W2W on exactly what they were all about. Until almost the end of our project our group had only a vague idea of what W2W really does. We actually had a meeting with one of the founders of W2W and we were shown the prototype Enzi they already had as well as where given an in depth look at the company. It was exciting for our group to see what where were potentially designing for. The largest interaction we had though had to be during the one week were we were having trouble with our project and we were bouncing ideas off of the electrical engineer from W2W. We conversed with them via email and phone. We were able to assess that we were on the right track to solving the problems that the project was presenting to us. Some problem existed like switching losses and voltage overshooting on the MOSFET drains. The electrical engineer from W2W gave us pointers after reviewing our designs as well as our oscillograms that we had given to him.

So, all in all our interaction with W2W was a great experience for our group. This is because not only were we funded by a company but to also be able to reach out at any time and get feedback from them as we needed help. Again please see Appendix B for more information on W2W.

2 Introduction

The purpose of this project is to design and prototype the DC-DC boost stage of a pure sine wave inverter. The DC-DC boost stage must be capable of operating at a continuous 300W and must be able to handle all reasonable load types.

2.1 Introduction to DC-DC Converters

In this section we will discuss different types of boost converters and their typical applications as well as their strengths and weaknesses. During the course of our research, we looked into the various types of dc-dc boost converters in literature to better understand the theory behind dc-dc conversion and to get a grasp on the number and types of converters available. By doing this research, we hoped to narrow our search for a converter that fits well with our overall design requirements.

2.2 Types of DC-DC Converters

DC-DC Boost Converter

The most basic type of boost converter consists of very few parts and is very straightforward. This type of converter charges an inductor with current flow while the switch is closed, and uses that current when the switch is opened to produce a voltage across the load that is higher than the initial voltage applied to the inductor. A filter capacitor across the output keeps the voltage from dipping too low across the load while the inductor is charging, and a diode ensures that the capacitor does not discharge itself across the switch when it is closed. The theory is that if one can open and close the switch fast enough, the load will see a seemingly constant voltage that is boosted to some degree compared to the original voltage applied to the circuit. The ratio of output to input voltage depends on the duty cycle of the switch opening and closing, with higher ratios occurring with higher duty cycles.

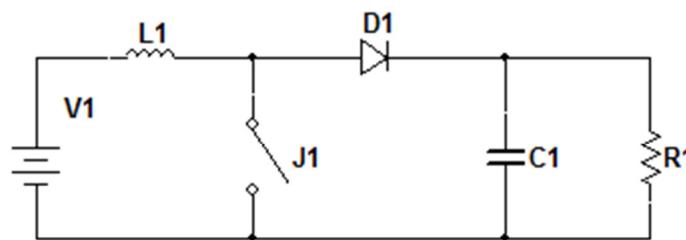

Figure 1: Basic boost converter schematic diagram

To analyze this circuit, we must first assume that the inductor current is continuous and always a positive value, the capacitor is very large and holds the output constant, and the parts are ideal. We start with the switch closed, which allows current to flow through the inductor from the voltage source with no path resistance. This causes a steady increase in current over time, whose maximum value depends on the inductance of the coil, the voltage of the source, and the amount of time the switch is closed. Assuming that T is the period of oscillation and D is the percentage of time that the switch is closed, we can put this relation into equation form as follows:

$$\frac{\Delta i}{DT} = \frac{V_s}{L}$$

Equation 1: Current, voltage, inductance, & time relation of a DC-DC boost converter closed switch condition

$$\Delta i = \frac{V_s * DT}{L}$$

Equation 2: Equation 1 rearranged to solve for current change in time

When the switch is open, the inductor current decreases linearly while the inductor pushes its current through the diode and into the output capacitor and load. The rate of change is dependent upon the same factors as the closed switch case, with the addition of the output voltage of the circuit impeding current flow. For this case, the governing equation is as follows:

$$\Delta i = \frac{(V_s - V_o)(1 - D)T}{L}$$

Equation 3: Current, voltage, inductance, & time relation of a DC-DC boost converter open switch condition

For steady state operation, the net change of current between the on state and off states must be zero. Therefore, we can set up the two equations as follows:

$$\frac{V_s * DT}{L} + \frac{(V_s - V_o)(1 - D)T}{L} = 0$$

Equation 4: Open & closed circuit conditions averaged for one period

Solving for V out, we get:

$$V_o = \frac{V_s}{1 - D}$$

Equation 5: Output voltage equation for a DC DC boost converter

There is a minimum value of inductance required so that the current doesn't drop to zero when the switch is open. This minimum inductance value may be computed by:

$$L_{min} = \frac{D(1 - D)^2 R}{2f}$$

Equation 6: Calculating minimum required inductance for a DC-DC boost converter

There will be an output ripple since the capacitor cannot be infinitely large. The amount of ripple present is governed as follows:

$$\frac{\Delta V_o}{V_o} = \frac{D}{RCf}$$

Equation 7: Calculating output ripple for a DC-DC boost converter

Buck-Boost Converter

This type of dc-dc converter is extremely similar to the dc-dc boost converter in that it requires the same number of parts, but rearranged slightly. The inductor and switch have their positions reversed, and the diode is turned backwards. This configuration supposedly allows the output to be either higher or lower than the input source, though we do not need this feature for our project.

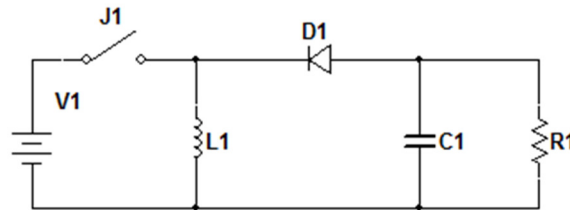

Figure 2: Buck boost converter schematic diagram

The equation and analysis that held true for the DC-DC boost converter is exactly the same for this circuit while the switch is closed. When the switch is opened, there is a polarity reversal, and the source voltage from the battery does not help the inductor supply voltage to the load. The output voltage for this circuit is:

$$V_o = -V_s \left(\frac{D}{1-D} \right)$$

Equation 8: Calculating output voltage of a Buck-Boost converter

The other equation that changes from the original boost converter diagram is the minimum inductance required. That equation is:

$$L_{min} = \frac{(1-D)^2 R}{2f}$$

Equation 9: Calculating minimum inductance required for a Buck-Boost converter

Ćuk Converter

The Ćuk converter is a dc-dc converter with an interesting mode of operation. The principle is that you use the same inductor switching technique as the previously discussed converters, but instead of providing this current directly to the load, you use it to force a charge upon a series capacitor. When the switch is open, the current that was stored in the inductor is forced through the capacitor, whose net positive voltage causes the diode to turn on and provide a low resistance path for the current, and results in a voltage drop across the capacitor. When the switch is closed, the inductor charges again, but the capacitor now has a net negative voltage at the anode of the diode, forcing it to turn off. The only path left for the capacitor to discharge through is the load circuit, which uses both a capacitor and inductor to smooth out the output waveform. When the switch is closed again, the same thing happens with the source side inductor-capacitor pair, but the load side inductor, now with a diode that is turned on, will discharge and attempt to keep the current and voltage through the output the same.

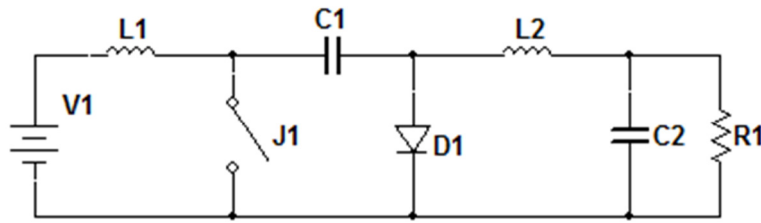

Figure 3: Ćuk converter schematic diagram

Surprisingly, this circuit has the same output voltage equation as the buck boost converter. However, this circuit has a much different output ripple voltage, which is characterized as being similar to a buck converter:

$$\frac{\Delta V_o}{V_o} = \frac{1 - D}{8L_2C_2f^2}$$

Equation 10: Calculating output voltage ripple for a Ćuk converter

This circuit also has two separate minimum inductor values, depending on which inductor you are referring to:

$$L_{1,min} = \frac{(1 - D)^2 R}{2Df}$$

Equation 11: Calculating minimum required inductance for L1 for the Ćuk converter

$$L_{2,min} = \frac{(1 - D)R}{2f}$$

Equation 12: Calculating minimum required inductance for L2 for the Ćuk converter

SEPIC Converter

The SEPIC converter is similar to the Ćuk converter in that it has similar construction and the same part count and type, but the positions of the load side inductor and the diode are swapped. This allows the capacitor and inductor to charge the parallel inductor, capacitor, and load when the switch is open. When the switch is closed, the net positive charge on the load forces the diode off, which makes it difficult for the capacitor to discharge since the load side inductor still wants to source current. Meanwhile, the source side inductor is charging current, so once the switch is opened again, the capacitor is not as discharged as it otherwise would have been and reaches a higher value on the continuing cycles until steady state is met.

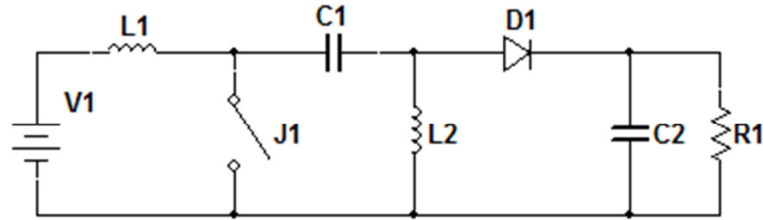

Figure 4: SEPIC converter schematic diagram

The output voltage relationship for this circuit is:

$$V_o = V_s \left(\frac{D}{1-D} \right)$$

Equation 13: Calculating output voltage of the SEPIC converter

The output ripple voltage seen on this circuit is:

$$\frac{\Delta V_o}{V_o} = \frac{D}{RC_2 f}$$

Equation 14: Calculating output voltage ripple for the SEPIC converter

In this circuit, capacitor C1 has a required value of:

$$C_1 = \frac{D}{R \left(\frac{\Delta V_{C1}}{V_o} \right) f}$$

Equation 15: Calculating minimum capacitance required for circuit operation of a SEPIC converter

Flyback Converter

The flyback converter relies on the principal that using a switched topology means that you can use a transformer to achieve a better dc-dc conversion ratio while not suffering too badly from transformer losses. The idea is to use a switch to control the amount of time the primary side of the transformer is allowed to charge, relying on the transformer's internal inductance to replace a conventional inductor in these types of circuits. The capacitor, diode and load configuration is identical to the dc-dc boost converter circuit diagram.

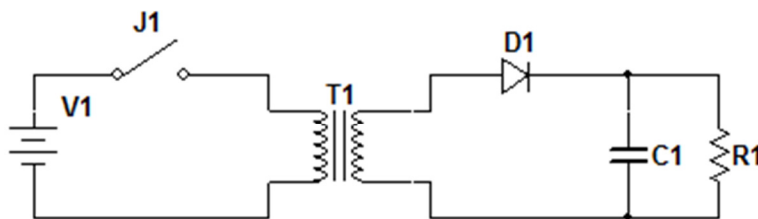

Figure 5: Flyback Converter Schematic Diagram

The output voltage of this circuit is very similar to the buck boost converter, except that there is no polarity reversal, and the transformer turns ratio is taken into account. The output equation for this circuit is:

$$V_o = V_s \left(\frac{D}{1-D} \right) \left(\frac{N_2}{N_1} \right)$$

Equation 16: Calculating output voltage of a Flyback converter

The output voltage ripple is the same as the DC-DC boost converter. In this circuit, the transformer acts like the inductor. Therefore, there exists a minimum amount of magnetizing inductance in the transformer for the circuit to operate properly.

$$(L_m)_{min} = \frac{(1-D)^2 R}{2f} \left(\frac{N_1}{N_2} \right)^2$$

Equation 17: Calculating minimum transformer magnetizing inductance for a Flyback converter

Half Bridge Converter

The half bridge converter is a converter design that uses a transformer with a center tapped secondary with some diodes and a load. The duty cycle is split in half among the two source side switches, with the duty cycles for each switch computed as the amount of time spent in the on state during its half cycle. The output on the other side of the transformer sees a flat topped, pulsated AC waveform from the transformer, which is rectified by the two diodes to produce a DC waveform that has on and off periods. The inductor and capacitor work as a pair to smooth out the resulting waveform across the load.

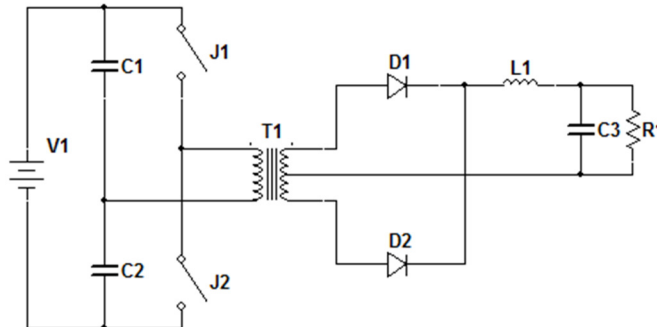

Figure 6: Half Bridge Converter Schematic Diagram

The output voltage of this circuit is:

$$V_o = V_s \left(\frac{N_2}{N_1} \right) D$$

Equation 18: Calculating output voltage of a Half Bridge converter

There are more techniques that can produce a boost in DC voltage, and many more considerations that must be taken when designing a system to do so. For additional information about boost converter topologies, consult reference material discussing the topic[1].

2.3 Research Space/ Goals

With an idea of the types of DC-DC converter topologies available, we came to define a number of goals that we wanted our design to meet or exceed. We realize that we may not be able to meet all of them, but we wanted to ensure that our inverter is capable of handling at least a 300W load at the output, the parts used in constructing the final design have a cost of \$20 total or less, reach at least 170V at the output, and have under a 5% $\Delta V_o/V_o$ ripple voltage. We also wanted the final design to have a form factor smaller than half the volume of a standard DVD drive in a modern computer. Some things that cannot have a quantitative value but were still important was to ensure that the individual parts were easy to get at for replacement and as many of the parts as possible be able to be substituted with scrap parts.

2.4 Purpose of Circuit

Our DC-DC converter was developed in order to provide the voltage boost needed to convert $12V_{DC}$ from a battery to the voltage levels required to replicate AC power equivalent to what would come from the electrical grid. The inverter that this boost converter supplies power for will act as a standby power supply for medical equipment should the grid experience a temporary power problem during a critical operation. Our converter was also designed with a secondary purpose in mind: To reuse good parts from existing waste power electronic material. Much of the electronics in these waste supplies is still good and can be used for many years, but the entire unit is usually disposed of after the original user decides to get rid of it. Recycling these old used parts was a driving factor during the design phase of the project.

2.5 Prior Art

Before starting on the endeavor of designing our project we decided to get a good idea of what was already on the market. This provides a few benefits for us since it will give us a baseline for what our product should have to compete with as far as price, form factor, and features go. We mainly researched AC inverter designs since our product is intended to fit into one, and many different products already out their available to the general public. However there are two types of inverters out there on the market: true sine wave inverters that produce a perfect sine wave output, and a modified sine wave output. Most consumer inverters available on the market that are inexpensive and are modified sine inverters. Modified Sine wave inverters have a problem that since they have almost instantaneous voltage transitions this produces a lot of high frequency content that can be harmful to some sensitive equipment. Such equipment such as radios, TV's, computers, or printers may not operate off of these modified sine wave inverters, without excess noise or unwanted operation. On the next page is a picture of a true 120Vrms (170V peak) sine wave, a 120V square wave and a 170V modified sine wave. The advantage over a 170V modified sine rather than a 120V square wave is first lower harmonic distortion and secondly since it reaches the full 170V more electronics will work with it, since all of them expect to be reaching that peak voltage and some may need that full 170V to function properly.

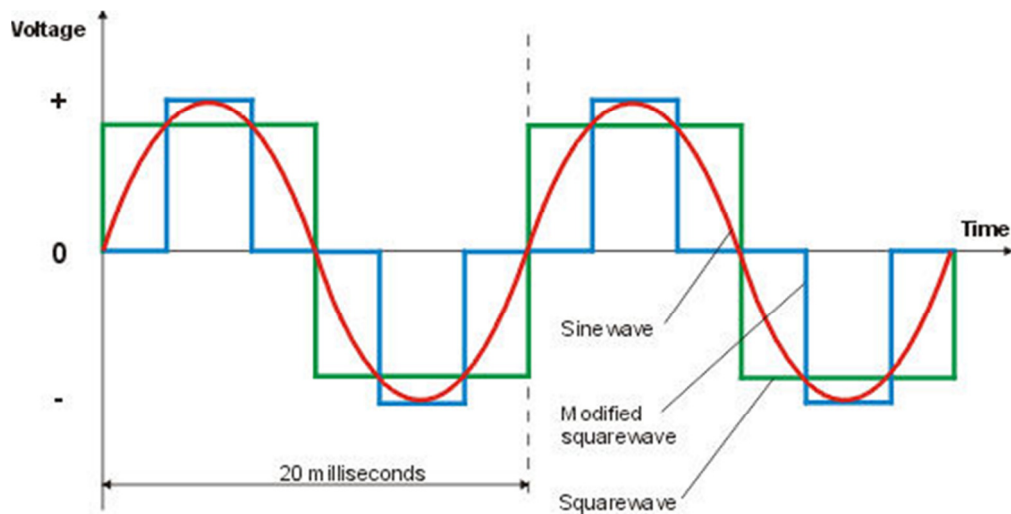

Figure 7: Inverter waveform types[2]

Since one of our earliest design goals in our project was to try to construct a cheap DC to DC converter for use in a pure sine wave inverter, we decided that our research into existing products should focus on pure sine wave inverters only. We also entertained the fact that perhaps our product could go into part of an interruptible power supply unit for hospitals in other countries that have less than reliable power. So our research yielded a representative product of what a hospital would use a modified sine inverter, and a few pure sine inverters for comparison. To follow will be the analysis of the features of each. Some information will not be complete on all of them since not all datasheets even between different models made by the same company contain the same information, but the comparison will be as complete as possible with the given information that the manufactures release with the product.

The major manufactures that where researched where Samlex, Triplite, Wagan and AIMS. These where popular major manufactures that were found to be carried by many stores online and the products they made where targeted to consumers groups from commuters that needed wall current, campers/RV users, boat users and offsite power. The research however did not focus on the higher wattage inverters but rather the lowest power ones that where around 300W which is another design goal that we were shooting for. A 300W inverter was actually some of the lowest wattage inverters that many of these companies made; most went up to a few thousand or 5000W. Features that where documented between the 9 models that were found to be suitable where power output, surge power output, price range, output ripple, cooling method, battery low voltage feature, low battery power off feature, THD, no load power consumption, efficiency, size, weight and circuit protection methods. Again as previously mentioned not all of the models listed contain all of the information listed above.

Form Factor

As far as form factor goes most of the models where close to the same. The weight varied between about 3 and 7lbs and the size is about 3"x6"x8" (HWD). This is about the size of a CD-ROM

drive in a computer and 2 to 3 times heavier. The two heaviest products were the 300W inverters made by Samlex the SA-300-12 and the S300-112. They weighed in at 7.7lbs and as the model numbers suggest and the datasheets the two products were almost identical. The lightest product was the Samlex SSW-350-12A weighing in at only 1.5lbs. Almost all models were also equipped with a fan to assist in cooling ability.

Output

When searching for inverters the goal was to find inverters with a 300W rating so that we could have them as close to the wattage that our design was shooting for. The inverters that were researched ended up being between 300 and 400W because some companies either did not make an inverter with 300W but somewhere higher or lower. Also a very interesting find was the fact that all of the inverters had a surge power rating of close to 200% of the inverters power output. The find was not surprising as some devices can have some nasty transience, especially if looking into the device. Most have capacitors that need to be charged, so there will be a surge of current into the device that could blow the inverter if it cannot handle that short power spike. Another figure that the inverters all fell within a close group is the output voltage tolerance while some specified it as a pure percent, and some as a voltage range they all fell within a 10V difference which is good considering that is better than the tolerance on most wall outlets.

Prior Art Comparison Table

number	1	2	3	4	5	6	7	8	9
Model num.	PWRI30012S	2201 Elite	HCRK	PV375	PST-30S-12A	SA-300-112	SSW-350-12A	S300-112	SK350-112
Manufacture	AIMS	Wagan	Tripplite	Tripplite	Samlex	Samlex	Samlex	Samlex	Samlex
PWR Output	300W	400W	300W	375W	300W	300W	350W	300W	350W
Surge PWR	600W	800W	750W	600W	500W	400W	700W	400W	700W
Price	~\$99	\$95-120	~\$1,195	~\$72	\$115-160	~\$194	\$159-113	~\$300	~\$281
Output V Ripple	+/- 3%			115 +/- 8V	+/- 3%	+/- 5%	115 +/- 5V	+/-5%	+/- 5%
cooling		fan	fan	fan	fan	fan	fan	fan	fan
Bat. Low V alarm	10.5 +/- .5		yes	yes	10.5V	LED	11.0 +/- 0.5		11V
Bat. Low V s/d	10.0 +/- 0.5				10V	10 +/- 0.5	10.2 +/- 0.5	10 +/- 0.5	10.5
THD		<3%			<3%	<6%		<6%	<3%
No load pwr consum.	< 0.7A	<0.35A		0.65A	<0.7A	0.24A	<0.5A	0.24A	1.25A, standby 0.25A
Load Eff.	Full 90% 1/3 95%	max 90%			~85%	~89%	~89%	~89%	~89%
Size (HWD)(")	2x6.2x6			2x4.25x7	2.6x5.8x8.5	2.8x6.1x9.3	2.24x6.10x7.87	2.83x6.10x9.33	2.44x5.78x8.42
Weight (lbs)	2.8			2.3	3.3	7.7	1.5	7.7	5.95
Circuit protection	15V	overload 400-450W, fused, auto shutdown	battery pack 12hrs, battery charger, RUI	fused 40A	fused 40A, 16.5V shutdown	fused 40A, 15-16V shutdown, overtemp shutdown	15.0 +/- 0.5V shutdown	fused 40A, 15-16V shutdown, overtemp shutdown	fused 20Ax2, 15.3V overvoltage shutdown

Table 1: Prior Art Compare

Existing Inverter Design on the Market

The most intuitive place to look for hints on how to design a good AC inverter is to look at the existing market designs of inverters. Unfortunately for the researchers, companies like to hide their designs so that their competitors cannot reproduce and improve on their hardware. Luckily, designs can usually be reverse-engineered (mostly) by looking at the insides of the physical product, so long as some form of destructive anti-tampering strategy isn't used by the manufacturer to prevent such research from being done (such as liberal application of sticky heat conductive material over the part numbers and traces).

We purchased an inverter around the power range that we are looking for in our design to ascertain how the product was designed, and what we could learn from it.

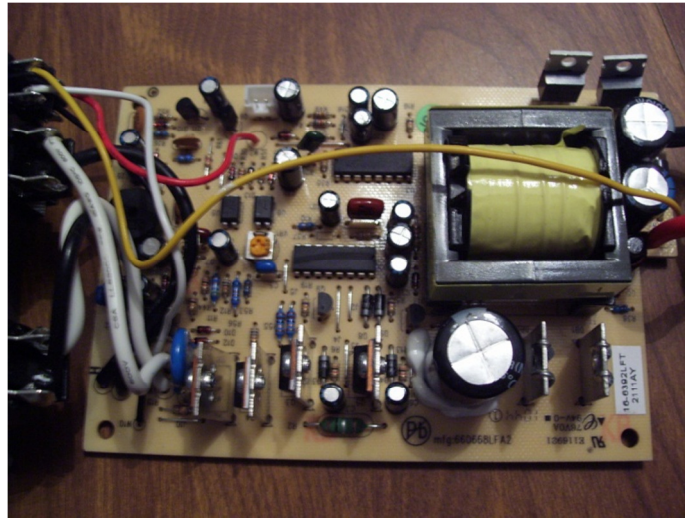

Figure 8: The PV375 power inverter from Tripplite

The inverter that we obtained is the 375 Watt Tripp-Lite “PowerVerter”. After receiving it via shipping, we opened up the case and took note of the parts used and how they were connected. Specifically, we were concerned with the initial voltage boost stage of the inverter, as that is the part of the design our project is based upon. We traced all of the parts from this stage and created the schematic diagram found in the appendix.

This schematic is extremely reminiscent of the designs we found while searching through the internet for schematics available online. There is a transformer with a center tapped primary with two MOSFET switches to ground on either side to double the effective input voltage across the transformer, and relies on the turns ratio of the transformer to boost the voltage for the output full wave bridge rectifier and capacitor bank. Through testing, we found that the switching frequency of the MOSFETs is just under 40KHz (no load), and it seems that the two sides of the transformer are magnetically isolated from each other. The closest literature circuit topology to these circuits is a push-pull converter that is modified to have a single secondary output with a full wave bridge rectifier at the output.

At first, this analysis seemed somewhat finalized, but upon measurements with the oscilloscope probes we found that the drains of the MOSFETs are biased to 24V while in the off state rather than the 12V we expected. We were very confused by this, because in essence it meant that we were passing the rough equivalent of a 24V peak sine wave through the transformer from a 12V DC source. We continued studying the circuit to find the answer, and initially thought that the diode, capacitor and inductor combination formed a boost converter before the signal hit the transformer. But the topology was wrong, and after consultation with an outside resource, we found the correct conclusion. When one half of the primary is energized, the voltage is transferred via electromagnetic coupling to the secondary. However, if the other half of the primary is open, it too will be affected by the first half of the secondary and energize, creating a total of 24V across the primary. Since the turns ratio of the transformer involves

the entire primary and secondary side, it is the 24V total that is passed through on the primary to the secondary, and the secondary will see twice the voltage compared to a single primary winding.

We were not able to find any other designs that did not follow this general principle. It seems to be the most tried and true method used in the industry, but on the positive side the design confirmed what we were initially thinking during our brainstorming sessions. There is far too much current flowing through the transformer if it is connected directly to the 12V input, so an initial boost stage is required to bring the current down enough for a transformer design to be feasible in our cost and size range. This design opened the door to us a bit so that we could seriously reconsider the use of a transformer in our design instead of a two stage boost topology. Another thing worthy of note about this circuit is that all of the components were far above specification in terms of how much voltage normal circuit operation would see. In some cases, the voltage rating was above double the amount that we measured with our tools. The inverter must be an extremely durable design as a result, but had us wondering why they went so far above the expected values.

2.6 Real World Parts

Some research into basic parts was also done to investigate what types of parts we can expect to be using in our coming designs. During this research, we came across a real world circuit that used a power MOSFET labeled STB160N75F3. After a quick search through Digikey, we found the datasheet for this part, and discovered that it can provide up to 120A of current with an internal “on” resistance of only 4mΩ! The total amount of voltage it can handle across its source and drain is 75V, which is more than plenty of headroom for our source side switching circuit. With an average input current of 30A expected for our circuit, this would mean that while the MOSFET is turned on, it is only dropping 3.6W across its terminals, which is fantastically low for semiconductors handling that much current. It also would probably not require too large of a heat sink, freeing up our budget and space constraints a bit.

Another power MOSFET we found was the FDMS2734. This is a 250V MOSFET that can handle a continuous current of 2.8A, and that value can be pushed higher if the current is pulsed like from a switching circuit. This MOSFET also has an internal resistance of less than 200mΩ at reasonable temperatures, which means that at an average output current of 2A from our circuit, we can expect a power drop of less than .8W from this part if we chose to replace any diodes on the load side of our circuit with MOSFETs to help increase circuit efficiency (to bypass the combined internal resistance of diodes and their inherent small forward voltage drop across them).

2.7 Safety Standards

In our endeavour to construct a product in the most complete manner we felt as a group that we needed to look into safety standards. Since our design might one day go into a real world product we wanted to safety keep in mind, so that when building and designing our project it would be not only complete but safe for use. It is our understanding that our project must not only be functional but be safe to use. So some research into how safety standards are met we felt was going to be beneficial to our project.

So once again going back to the prior art research that we previously completed we looked at the documentation each of the inverters to see what safety standards that they complied with. From there a list was generated containing all of the different standards that the inverters listed. The list

yielded both standards from the US and Europe. Since our one application of our project might be part of a UPS for hospital use in a third world country, we specifically played close attention to the standards listed in the medical grade UPS system researched in our prior art. The category of safety standards ranged from EMI emissions and transmission to shock prevention.

Our plan of attack was to find out what each different standard was and then try to gear the design of our project so that we could adhere to as many as was feasible to do so. However this turned out not to work as planned. Once the list was complete we started on the next step which was to find out what each standard covered and some basic information about it. Using search engines we went through each one trying to find this seemingly elementary data and we hit our first road block. The description of what the standards covered for vague at best. Then trying to find specifics from there was even more difficult. There were not websites out there that offered a .pdf or some sort of documentation of what these safety standards were, what parameters were tested to meet them. Every site wanted an absurd amount of money for a .pdf of what the standard was. It was cheaper to buy a semester's worth of textbooks than the safety standards guide book. Even the outdated past revisions were a few hundred dollars or more.

Listed below is the overview of the safety standards:

Safety Standards List

- UL-606001-1
- NEMA 5-15R AC outlets
- NEMA 5-15PHG plug
- CAW/CSA-C22.2 NO.601.1M90
- UL1778
- UL 458 -> GFCI
- EN55022 class B
- EN 61000-3-2,3
- EN60950-1
- E-13*72/245/EEC,95/54/E6
- EMI conduction/radiation -> FCC class B

Safety Standards List Expanded

EIC/UL-60601-1 [4]

Is a general safety standard for all medical electrical equipment. The goal of this standard is to specify general requirements for all medical equipment to adhere to. However other standards that specify more in depth particular standards override this general standard.

This standard also sets limits for leakage current to the patient attached to the equipment or the person operating it. Some other items specified are trace spacing on PCB boards to eliminate or reduce such things as creepage/leakage voltage/current.

As far as the research that was available which isn't much, the current revision available is the 2nd Edition and the 3rd Edition will not be out until July of 2013.

NEMA 5-15R AC Outlet/Plug [5][6]

This is a standard for how outlets and plugs for the use of 125V AC up to 15A. It specifies how the physical plug and outlet must be constructed in order to ensure safety. The plug and outlet is three

wire, two pole setup. There are 3 prongs on the plug and they are for hot, neutral and ground. The ground pin is either round or half round in shape and is $\frac{1}{4}$ " above the hot and neutral prongs. The hot and neutral prongs are spaced $\frac{3}{4}$ " apart and are $\frac{1}{8}$ " shorter than the ground pin. This is to ensure that the ground pin is the first pin to be connected when plugging the plug into the socket. The neutral prong is also wider than the hot prong because the NEMA 5 standard is polarized unlike the older NEMA standards that are not. Also the NEMA 5-15R socket may also have a t-slot in the neutral to support the 5-15P plug where the neutral blade is rotated by 90degrees.

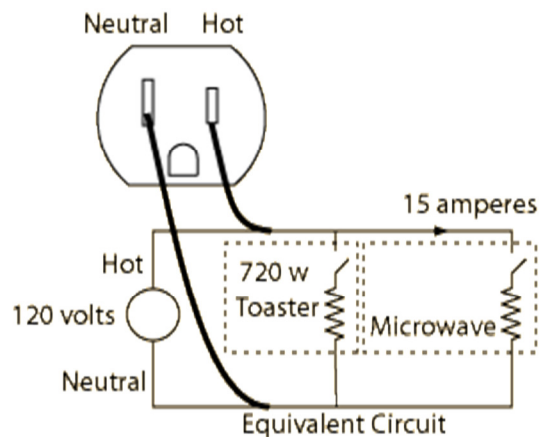

Figure 9: NEMA 5-15R diagram[5]

This polarization ensures then when a device is plugged into a NEMA 5 outlet and the device is powered off by a switch located on the device that the device will be at ground potential. Otherwise the device is at 120V potential and all that is needed is a ground path and electric shock could result.

CAW/CSA – C22.2 No. 601.1M90 [7]

Is a Canadian safety standard for medical safety equipment is equivalent to the US UL-60601-1 standard.

UL 1778 [4]

The scope of this standard covers uninterruptable power supply equipment (does not cover devices intended for medical use). This standard covers nearly every aspect of the UPS below is a list of a few of the items covered in this standard.

- Enclosure material
- Wire enclosure openings
- Electrical shock
- Spacing
- Over current protection
- Flammability
- Batteries
- THD

Also contained in the standard are outlines for tests the UPS must pass in order to be certified that that particular design meets or exceeds the standard.

UL 458 [4]

This standard covers fixed/stationary power converters, power converting systems, and accessories having a nominal voltage of 120V and/or 240V AC or DC or 24V DC or less. The standard covered only these devices or accessories whose applications are limited to marine crafts and land vehicles and the devices are not exposed to outdoor conditions.

EMI conduction/Radiance -> FCC class B [8]

Falls under FCC part 15 that states certain aspects of how devices must operate. There are two main classes of certifications Class A and Class B. Below is a brief description of what the difference between the two are.

- Class B
 - For intended use in residential/domestic environments
- Class A
 - For intended use in non-residential/non-domestic environments may cause interference and require the user to take adequate corrective measures.

Also in FCC part 15 there are limits on EMI both conduction and radiation by the device. The device must pass these limits and depending on its application will get a Class A or B rating that it passed FCC part 15.

Conclusion

In the end we did not end up having the capability of adhering to any of the safety standard because we did not have any sort of metrics in which to assess that our device met those standards. In order to get the information required to make informed design changes to meet said requirements we would have to spend thousands of dollars to buy the standards where everything is explained. So in the end we turned to focus more on the functionality of our project than the safety standards.

3 The DC-DC Converter Type We Chose

There were many factors involved with the choice in how we wanted to proceed to create our final design. We needed to consider size, cost, performance, and isolation characteristics of all our options and select the one that worked best with our design requirements.

3.1 Advantages and Disadvantages with Our Possible Choices

The ordinary DC-DC boost converter circuit is a very low cost solution to dc-dc voltage conversion, it can reach over 90% efficiency, and it does not take up much space. However, this circuit is susceptible to output ripple with higher duty cycles, it does not provide any sort of isolation between source and load, its ripple is partly dependent upon the load, and due to real world losses anything above a ratio of 3:1 output to input becomes exceedingly difficult to get any sort of good efficiency out of, not to mention that it becomes difficult very quickly to achieve anything more than a 4:1 output to input ratio in general. The ratio we need to boost 12V to 170V is 14.17:1, which is far beyond what this circuit is supposedly capable of.

The buck-boost converter has the same advantages as the normal dc-dc boost converter in that it can be constructed from inexpensive parts and does not take up much space, but it also suffers all of the disadvantages as well, and the added disadvantage of producing a polarity reversal at the output, causing there to be no true common ground in the circuit. The Ćuk converter is less susceptible to the effects of output ripple changing due to changes on the load, but suffers from efficiency losses at high boost values, is more expensive to produce due to the increased number of parts and additionally produces a polarity reversal at the output. The SEPIC converter loses the Ćuk converter's advantage of better output ripple regulation, but it does not provide a polarity reversal and uses the same number of parts. All of these topologies are limited by high boost efficiency losses.

The flyback topology introduces two big advantages over its transformer-less cousins. The first is that the circuit now provides magnetic isolation between the source and the load of the circuit. The second, and more important to us, is that the turns ratio of the transformer plays a direct part in the boost/buck conversion ratio, which enables a far greater range of efficient dc-dc conversion ratios than is otherwise possible. The flyback converter does have quite a few drawbacks. There is an additional cost in purchasing a transformer rather than an inductor, which are generally cheaper. The switching frequency must now also consider transformer losses, which must be kept to a minimum if you want a very efficient circuit. The transformer that one can use to power the load must be carefully chosen, as there is a minimum inductance requirement for the primary side of the coil for the circuit to function properly. The core is also somewhat easily saturated, forcing the user to use larger, more expensive

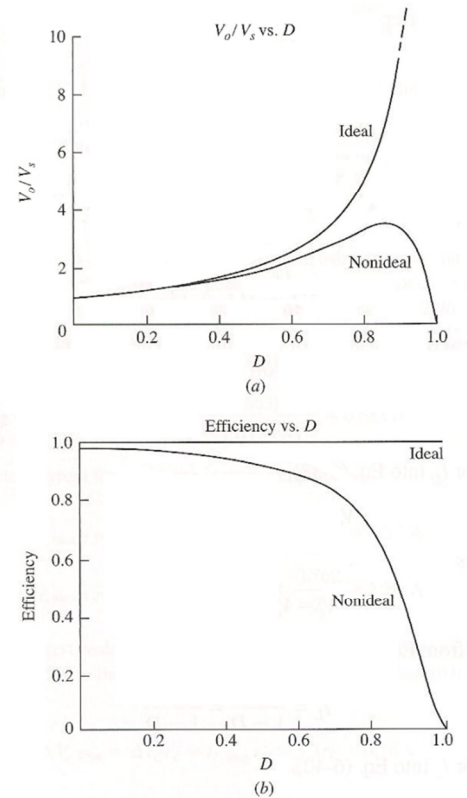

Figure 10: Typical efficiency graphs for a DC-DC boost converter[3]

transformers to do the job, and due to the transformer's primary inductance charging to the input voltage, the voltage seen across the switch while it is closed is twice the amount of voltage being supplied to the circuit.

The advantages of the half-bridge converter design is that each input switch only sees the input voltage from the source across it as a maximum, instead of twice the input voltage. The circuit does not saturate the transformer quite as easily as a flyback transformer, allowing smaller cores to be used. It provides magnetic isolation, can boost voltage quite a bit with minimal efficiency loss, and provides good DC regulation at its output. The disadvantages of this circuit, however, include the normal disadvantages associated with a design created with a transformer, in that the switching frequency needs to be selected with transformer efficiency in mind, the added cost and space of a transformer in a circuit, and the general loss in efficiency through a transformer. The output side of the circuit itself is a buck converter, so the amount of boost provided by the transformer turns ratio needs to be higher than the desired ratio to account for the small amount of voltage that is stepped down at the output. The circuit also fundamentally requires at least three capacitors, two switches, and two diodes, which is more than any other previously discussed circuit, and circuit cost and size would need to be taken into consideration.

The push-pull converter provides double the boost of a half bridge converter for the same turns ratio on its transformer. It shares all other advantages of the half bridge topology, with the added bonuses that the output is easily fitted with a full wave bridge rectifier and it does not require extra capacitors on the inputs. It also shares most of the disadvantages as the half bridge converter, with the extra disadvantage of having a total of twice the input voltage present upon each of the switches.

3.2 Our final decision

Before choosing which type of converter we wanted to go with, we looked carefully at all of our options and discussed them with our peers and advisors. It seems clear that in power, you want to electrically isolate what is happening at the high current side of the circuit from the low current side, in case a component between the two sides blows and creates and causes the low current parts to experience a very high current. We knew that even though we could use a two stage DC-DC boost converter to bring the voltage up to the necessary value, a transformer could do this just as well for around the same price and have the electrical isolation that we wanted.

Between all the different types of converters that use transformers, the flyback converter was one that we did not want to use. We want the circuit to be able to use as wide a variety of replacement parts as possible, and for a large part like the transformer we didn't want to cut out a large section of available transformers due to a minimum magnetizing inductance. This left us with the choice between the half bridge converter and the modified push pull converter. After looking at each topology, we decided that the one we would go with was the modified push pull converter. The main reasoning is that this converter had a nice characteristic of doubling the source voltage going through the transformer, which means that we could reduce the turns ratio of the transformer by a factor of two. There are also no real distinct advantages that the half bridge converter has over the push pull converter, so we went ahead and started designing around a push pull converter topology.

4 System Level Design

In order to maintain organization and ensure that each major function of the design is kept separated so that we could troubleshoot each section individually, we needed to follow a basic system level design pattern. This would also make the system easier to explain with the use of block diagrams and gives the ability to go through the circuit piece by piece.

4.1 How it works (Block Diagram Level/ qualitative explanation)

The basic system function as stated before is to boost a battery voltage of 12V up to over 170V while also supplying at least 300W of power at the system's output. In order to accomplish this using a push pull converter, the system needs to be broken down into a few steps.

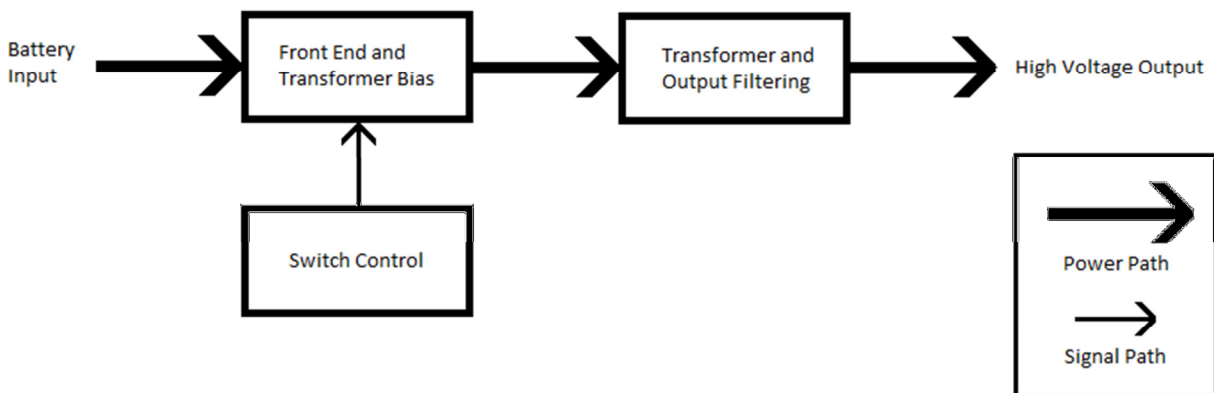

Figure 11: System Block Diagram

The input to the whole system is a 12V battery that is capable of supplying at least 30A of current to the circuit. Examples of what could provide this are car and marine batteries, both of which are capable of storing a very large charge and can source a lot of power. This voltage also supplies the switch control with power, but that section of the circuit uses such little power that in the block diagram it is not labeled as a power path.

The front end and transformer bias section of the circuit provides circuit and input protection functions as well as controlling the signal to the transformer. To ensure the circuit doesn't draw too much power from the battery if one of the components malfunctions, it needs a 40A fuse to immediately stop power to the rest of the circuit. The circuit also needs to filter the input voltage from the battery to ensure that any stray noise from the battery, which may originate from loading, stray signals picked up from the cables, or a quick intermittent break don't make it to the transformer. This is accomplished using a couple of capacitors to hold the charge from the battery and ground any AC signals from the source. This section also controls the signal to the transformer, directing the current path to alternate between the two legs of the transformer. It uses a couple of high power MOSFETs in order to accomplish this task. This block needs to have minimal resistance in the power path, and be able to sufficiently protect the circuit from stray AC signals as well as potential component burn out.

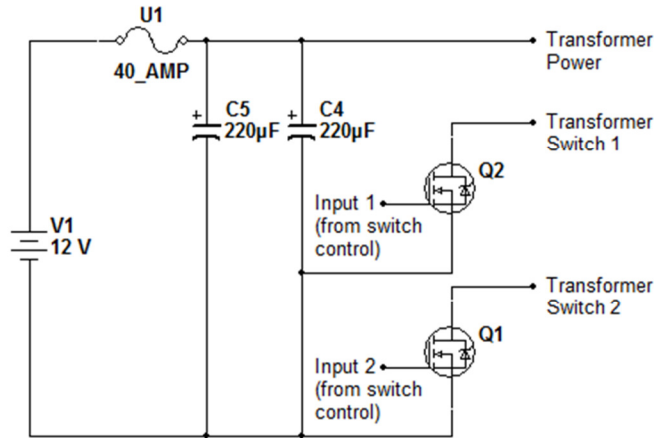

Figure 12: Front End and Transformer Bias Block Schematic Diagram

The switch control section of the circuit provides the signals for the MOSFET gates to tell the circuit when each leg of the transformer should have power. This circuit's "input" is its own oscillator, which directs the timing for the entire system. Ideally, the switch control circuit would produce two 50% duty cycle synchronized signals where they would alternate which MOSFET was on at any given time, whose frequency was somewhere between 80KHz and 120KHz. This can be accomplished either using a 555 timer circuit with an output inverter to create the two appropriate output signals, or by using a dedicated premade control chip with proper biasing. This circuit needs to be able to be reproduced with minimal changes in the signal characteristics between different units, and reliably produce a duty cycle that has no more than 5% change from the targeted 50% that we want.

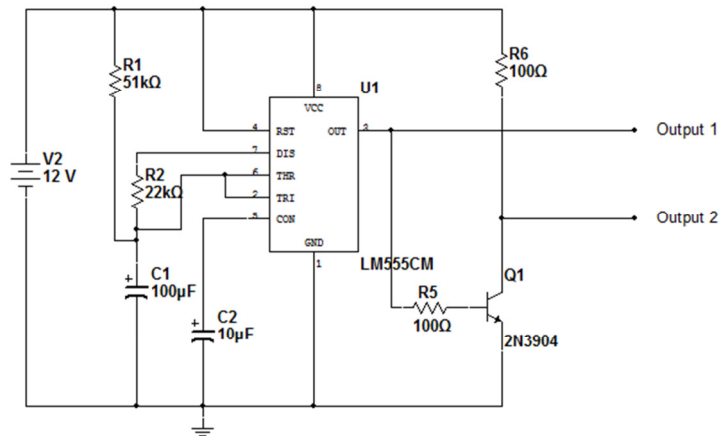

Figure 13: Switch Control Block Schematic Diagram

The transformer and output filtering section boosts takes the high power signal produced from the first two sections working together and increases its voltage to the desired level, then re-filter it back to a DC signal. A transformer with a dual primary produces a 24V signal across the input, which through the 1:10 turns ratio boosts the voltage up to an ideal 240V. The current then passes through a

full wave rectifier bridge which turns the rough square wave produced by the transformer into a rough DC signal. This signal then charges the capacitors on the output of the circuit, which filters out the imperfections of the input voltage and produces the high voltage DC at the output of the circuit. This circuit also needs to have minimal resistance through the power path, as well as being able to handle high voltages and large amounts of heat.

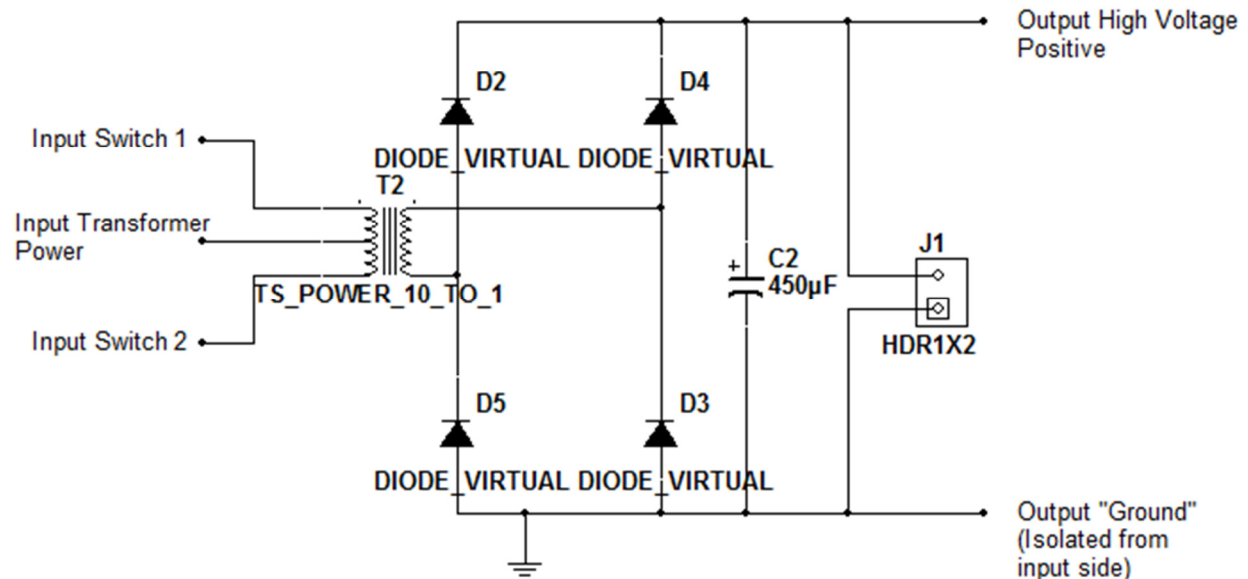

Figure 14: Transformer and Output Filtering Schematic Diagram

4.2 Control Chips compatible with our design

All DC-DC converters with a regulated output need a control chip to sense the amount of voltage at the output of the circuit as well as adjust the duty cycle to compensate for the amount of load present. In rare cases discrete external circuitry is used to perform this function, but usually it is cheaper just to buy a premade dedicated microchip. This being the case, we researched many manufacturers that supply these chips in the hope that we would find one that was compatible with our design. We also wanted to use the same chip for both stages in the case of a two stage design, since this was a possibility while doing the research. This primarily means that if the first stage boosted the voltage by a factor of four, we could need the chip to handle up to 48V on the second stage, limiting the number of choices we have.

We first looked at the company Zetek, who is listed on Digikey as producing some of these types of parts. However, on further inspection we discovered that they did not make boost converter control chips, but rather other types of various dc-dc conversion topologies. Therefore, we determined that this company did not meet our design requirements, and we began looking elsewhere shortly after.

We then looked at the manufacturer Fairchild Semiconductor, who does make dc-dc boost converter control chips. We scanned through their catalog, but found that the number of actual boost converter control chip types they produce are very limited. They mostly design their chips around the voltage and power levels necessary to drive LED circuits, so they do not produce anything that can

handle the high amounts of voltage and current that we handle. Therefore, we decided that Fairchild could not provide us with what we needed, and continued looking.

The company Analog Devices was looked at next. This company was far more along the lines of what we had hoped to find from the beginning, in that they produce a wide variety of dc-dc boost converter control microchips. However, this company didn't quite reach the voltage levels we were looking for. We did find one chip made by them, the ADP1621, which could possibly work for our design with some very careful and clever engineering, but the solution offered would not be preferred. Something of note that this company had in its specification sheets recommended trace sizes for handling different amounts of current, which is something we did not find with any other manufacturer. They also had a lot of other applications related documentation which may still prove to be useful for our design, even if we select a different chip. The search continued for a better solution, but the documentation of this chip stayed in the back of our minds.

National Semiconductor also makes a good number of chips that may work with our design. The LM5022, specifically, seems to meet every one of our design requirements. It can handle a very wide input range of $10.5V$ to about 60V, which covers the input ranges on both stages of our boost converter. It can handle up to a 90% duty cycle all the way down to none, and with the use of resistors can handle our output voltage and current ranges. With this as our control, we can regulate both stages of our boost converter to ensure that even the input to the second stage always remains within a certain range. It is always good to have multiple options, however, so we continued looking to see if we could find another chip that would work for us in case we ran into problems with this one.

We looked at Linear Technology for control chip solutions. We found that they produce many control chips that are compatible with our topology, but none of the solutions they offer meet the wide input voltage range that we require. We would only be able to use their designs on the first boost stage, because none of the chips we found were capable of handling 50+V of potential across its input terminals. With an already ideal chip that we found from another manufacturer, we didn't want to compromise with using two chips to control both stages, so we moved on to our final manufacturer.

Texas Instruments also makes a very wide variety of control chips for dc-dc converters. After searching through their parts catalog, we found the TPS40210, which like the LM5022 also meets all of our design requirements. It can handle the required input range for both stages (the headroom is a bit lower though), and it can reach an acceptable duty cycle range. Digikey also lists this part specifically as being capable of not only handling our input range, but our output voltage and current ranges was well, giving us far more confidence in using this chip. This is an excellent alternative to our other feasible chip, so we had multiple design paths that we could follow.

We had found two control chips that we could guarantee would work with our circuit, those being the LM5022 and the TPS40210. From the design of the DC-DC converter from the inverter we had bought, we had a working example of a SG3525A control chip in our hands as well. All we really needed from these chips was a working 50% duty cycle oscillator with adjustable frequency control, so when we looked at the big picture we realized that if we could do it with reasonable reproducibility between

manufactured units; we could also use a 555 timer circuit set to have a 50% duty cycle. We made our choice based on familiarity and cost. We were both very comfortable working with 555 timers and it was the cheapest apparent option. We knew we might run into problems finding ways to get the circuit as precisely close to a 50% duty cycle as we wanted, so we decided that should the 555 timer not give us the performance we wanted, we would use the SG3525A control chip as a backup, since we had a working example of it in operation if we needed to troubleshoot it. Seth also had some experience working with the TPS40210 PWM controller as well, so that would be our second fallback plan should both other choices fail us.

4.3 Detailed Front End and Transformer Bias Design

In order to supply 300W at the output of the circuit, and assuming that the input of the circuit supplies 340W due to efficiency loss, the average current that must enter the circuit from the 12V battery must be approximately 28A by ohm's law. We expect that the input current will have a significant ripple to it, due to the fact that since this converter is a switched topology. We decided that we would allow the input current to potentially swing +/-10A to allow for proper circuit operation, so a 40A fuse would be appropriate to protect the circuit from currents that exceed the design capabilities.

$$V = I * R$$

$$P = V * I$$

Equation 19: Ohm's law basic equations

We selected two 220µF capacitors in parallel to filter the input voltage for a couple reasons. First, we wanted to protect circuit operation should the battery receive a quick intermittent connection. We decided that if we assumed that the capacitors supplying power down to about 10V would allow the circuit to continue functioning, we could calculate the number of switching cycles that it would cover for loss of battery power.

$$V(t) = V_o(1 - e^{-t/R*C})$$

$$t = \frac{V^2}{P_{out}} * C * -\ln(1 - \frac{V(t)}{V_o})$$

$$C = t * \frac{P_{out}}{V^2} * \frac{1}{-\ln(1 - \frac{V(t)}{V_o})}$$

Equation 20: Capacitor discharge equation, the equation solved for time, and the equation solved for capacitance

Using the equations listed above, we could tune the value of C in order to predict the amount of time that the capacitors would allow proper circuit operation by themselves. We decided that we wanted a hold up time of at least 300µs (or 30 oscillations) just in case the cables the circuit was bumped and had a slight intermittent connection, but keeping the capacitor sizes in check by not asking for too high of a capacitor value. We found that a capacitor value of 348.81µF would suffice. After searching various databases from retailers, we determined that the most space efficient, economical

solution was to use two 220 μ F capacitors in parallel to achieve 440 μ F, which would also give us a hold up time of about 378 μ s, an extra seven switch oscillations. Also, with this much capacitance an AC signal would need to have a lot of energy in it in order not to be filtered out.

The two MOSFETs needed to be selected to have a fast switching time, high current handling, and low internal resistance. We decided to search for parts with a switching time of less than 100 times smaller than our switching period (at 100KHz this equates to less than 100ns) to avoid major switching losses, handle at least 40A of current, and dissipates less than 8W while turned on. We used ohm's law again to calculate the average power dissipated through the switches using 30A as our average current and 4A as our power. This led to a maximum on resistance of 8.8m Ω . After extensive searching, we found a part that met all of our requirements. The IRF3205Z N-channel MOSFET has turn on and turn off times of less than 100ns, is capable of handling up to 70A of continuous current (provided the proper heat sink is attached), and had a maximum internal on resistance rating of 6.5m Ω . We decided that this would be the MOSFET we would use for our final design, but for the first prototype we would use the RPF40N10 N-channel MOSFET with 40A rating, less than 50ns turn on and turn off times, and 40m Ω of internal resistance due to its quick availability and that we wanted to be able to measure how the signals in the circuit were affected when the MOSFET resistance was far too high.

4.4 Detailed Switch Control Design

The 555 timer circuit used in this design was a modified version of a premade suggested circuit from the 555 timer datasheet available from STMicroelectronics. The trick is that instead of the normal astable setup where the capacitor charges through R1 and R2 and discharges through R2, the resistor R2 is moved slightly so that the discharge pin must run through it before anything else. This causes the capacitor to charge through R1 and discharge through the voltage divider created by R1 and R2. So as long as the resistance while discharging is low enough to make up for the fact that it does not settle at 0V while discharging without being too low, you can get the rise time of the voltage on the threshold pin to equal the fall time of the voltage. This happens to occur at around a R1:R2 ratio of about 51:22, so a 51K Ω and 22K Ω resistor can be used for R1 and R2 respectively to produce an approximate 50% duty cycle (this information was given to us by the datasheet, since the actual rise and fall time calculations can be quite complex to solve for the appropriate ratio). The frequency of the output can then be adjusted by tuning the size of C1 as necessary. A value of 100 μ F provides a frequency of around 100KHz, as we verified through experimentation which was faster than substituting values for the equation until we got it right.

After the output of the 555 timer circuit, we needed to provide a second output that was the logical inverse of the first. Most cheap logical inverters could not handle sourcing enough current to charge the gate of the MOSFET quickly enough, so we decided to use a simple BJT inverter to get the job done. We selected the 2N2222 NPN BJT as a transistor that could handle the currents we wanted, and set it up into a common emitter amplifier configuration (which inverts the signal at the output). We selected 100 Ω resistors as current limiters to keep the current at a maximum of 240mA at any given time, both to protect the transistor from excess heat dissipation and to limit the amount of current used by the switching control circuit. With a maximum path resistance to the gate of the MOSFET limited to 100 Ω , we assumed the circuit would provide proper control to the rest of the circuit.

4.5 Transformer and Output Filtering Design

The heart of the design was the transformer, which provides the actual voltage boost, the critical function of the circuit. The design requirements of this part were that it was able to handle an average of 30A on its center tapped primary winding, had a turns ratio of 10:1, did not saturate at our switching frequency and current ratings, and was at least 80% efficient. We quickly found that it is very difficult to find such transformer available for purchase on the market that fit those requirements and did not cost an enormous amount of cash. In fact, the only way we could obtain a transformer like this was to hire a company to build a custom one for us, which would have been extremely expensive. In the end, we decided to make one ourselves to save us that cost. We took a ferrite core from a large transformer in our example ATX power supplies and rewound it to meet our turns ratio and current specifications. This way we could experiment with various other configurations if we so wished and be able to do it at minimal cost.



Figure 15: Our custom transformer coil

The diodes in the full wave bridge rectifier are necessary to ensure the AC signal from the transformer can be converted back to DC power. For this the criteria was simple: find the cheapest diode that could handle at least 300V (safety margin), 3A of current, and switch at less than 100ns like the MOSFETs that controlled the transformer. The STTH3L06 fit the bill, switching at 85ns, handling 3A of current, and could handle 600V of reverse bias if necessary.

Finally, the output of the circuit needed capacitors to filter it to a proper DC signal. We decided that it would be best if the output capacitors were relatively similar in size to the input capacitors, since in theory the output capacitors would be supplying the same amount of power compared to the input capacitors, but have 20^2 (400) times the amount of energy storage capability of the input capacitors (the voltage is about 20 times higher, so the energy by $.5CV^2$ is roughly 400 times greater). Since the power requirements are roughly the same at the input and output, this would give the rest of the circuit plenty of time to return to steady state conditions for a power disconnection situation greater than the amount of time that the input capacitors could handle. Calculated by multiplying the holdup time of the input capacitors from the previous section by 400, this gives the circuit a total of about 150ms holdup time at the output once power was disconnected at the input.

5 Simulations

One of the keys to good design is the ability to accurately simulate systems to ensure that the final product will be functional and behave in an expected manner. Another good design methodology is to use simulation whenever possible to determine the cause of an unexpected design problem and use it to find an acceptable modified design.

5.1 Spice Models

In the power electronics field, it is generally accepted that a SPICE model is the most accurate and reliable way to simulate your designs. We needed to test each circuit we designed in simulation to look for potential problems before ordering parts that could not be returned. This also allowed us to cheaply look into many design options at once, and helped us choose our circuit topology. We used the AMS simulator from Cadence to test various parameters of our designs, and to look for design errors.

5.2 Basic Realistic Transformer Model

Transformers do not have a discrete part type in PSPICE, and since many of the circuit topologies we were looking at use a transformer, we needed to create a reliable transformer model whose input-output characteristics would closely reflect its real world counterpart. The driving characteristics of a transformer are its primary and secondary impedances (the secondary can be scaled and added to the primary for simulation purposes), its magnetizing inductance (primary inductance), its secondary inductance (equals the primary times the turns ratio squared), and the fact that the primary and secondary are as ideally as possible mutually coupled. The result of this circuit is that a change of current on the primary will yield a scaled change in current on the secondary (and corresponding voltage changes). For our models, we needed a transformer with a center tapped secondary and a single primary winding. We modeled this in our design as two separate inductor pairs, with the primaries kept separate and the secondary windings connected in series. This was done to help with simulation time, since the simulator's engine code had an easier time dealing with two systems in parallel than a single complicated system. Once completed, we had created the following spice code:

```
.SUBCKT TRANSFORMER 2 3 4 5 6
RT 2 7 1n
LP1 7 10 10u IC=0
LP2 7 11 10u IC=0
LS1 8 5 250u IC=0
LS2 5 9 250u IC=0
RS1 8 4 5n
RS2 9 6 5n
K1 LP1 LS1 .999
K2 LP2 LS2 .999
RLOOP 3 5 1G
RBREAK1 10 3 1n
RBREAK2 11 3 1n
.ENDS
```

The equivalent visual based schematic is as follows:

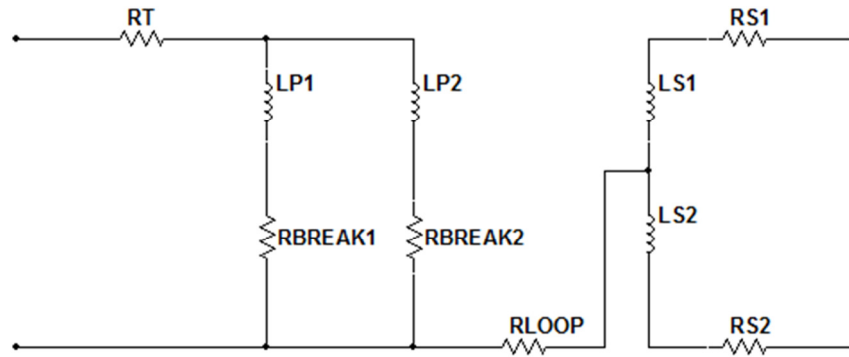

Figure 16: Schematic Diagram of the Transformer Model

In this schematic, RLOOP is used as a high impedance resistor connecting the primary side ground to the center of the secondary. PSPICE does not allow any circuit components to be left floating (in other words, every connection needs a ground point), so this resistor was necessary to help the tools set up the proper calculations. RBREAK1 and RBREAK2 were used to help prevent LP1 and LP2 from being directly connected at both ends, which causes an error to occur during simulation. Originally this was modeled as a single resistor in series between LP2 and RT, but it was discovered that the tools then used less efficient equations for calculations, greatly increasing the compiling time. Although it can't be seen here, it is assumed that LP1 has near perfect mutual inductance with LS1, and the same with LP2 and LS2. This model works very well with sinusoidal inputs, but dc pulses cause a very high instantaneous voltage to appear across the output, decreasing the accuracy of the tools and increasing compiling time.

5.3 DC-DC Boost Converter Model

The next spice model we made was a simple single stage DC-DC boost converter model. Fortunately there is no mutual inductance to worry about in these designs, and they are relatively simple in that they can be modeled almost exactly as they look in the visual schematics. For our DC-DC boost converter model we used a virtual switch with resistance to model our MOSFET switch temporarily, an inductor, a capacitor, and a diode. The rest of the circuit elements were there either to model real world losses, provide input or load, or to control the switching frequency and duty cycle. We created the following spice code:

```
.SUBCKT BOOSTER4X 1 2 3 4 ; 1=Power In,
2=PWM In, 3=Output, 4=Ground
.MODEL MOSSWITCH NMOS(KP=50 VTO=2)
.MODEL DIODE D(BV=500 VJ=0.7 IS=0 N=1
CJO=2p)
.MODEL VIRTUALSWITCH VSWITCH(ROFF=10MEG VON=3 VOFF=1)
LSW 1 5 10u IC=0 ; Switching Inductor
RLSW 5 6 2m
RMSW 6 7 4m
SMSW 7 4 2 0 VIRTUALSWITCH
D1 6 3 DIODE
X1 7 4 SNUBBER
X2 6 3 SNUBBER
C1 3 4 27u IC=0 ; Filter Cap
.ENDS
.SUBCKT SNUBBER 20 21
R1 20 22 1MEG
```

```

C1 22 21 .01n IC=0
.ENDS
V1 10 0 12
X1 10 11 12 0 BOOSTER4X
V2 11 0 PULSE(0 5 3123n 1n 1n 9.375u 12.5u)
RL 12 0 7
.PROBE
.TRAN 200u 51m 50.95m 50u UIC
.END

```

The equivalent visual based schematic is as follows:

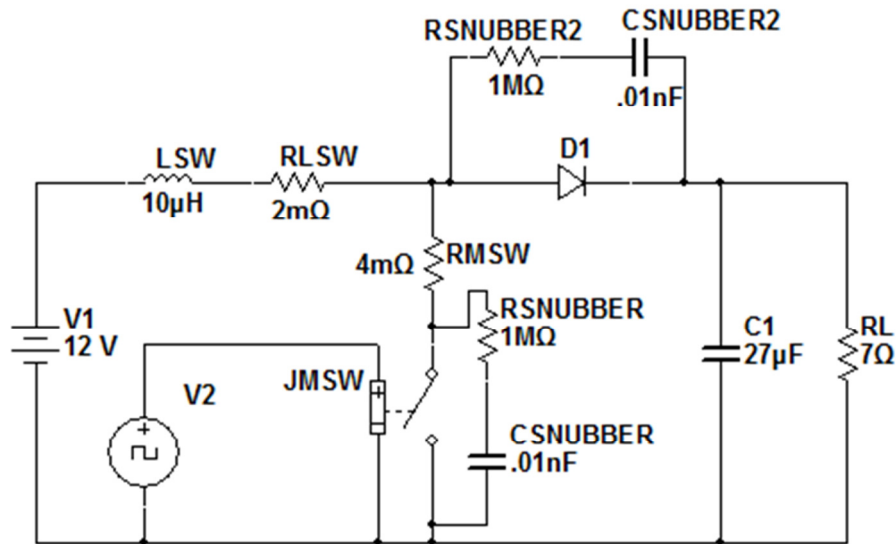

Figure 17: Schematic Diagram of the Boost Converter Model

Aside from the resistances that were obviously added to help model real world losses, there are also “snubber” resistances and capacitances across the solid state components. These are used to help create a realistic time constant for the voltage across the parts, to assist in the simulation of the code. Without these parts, a “timestep too small” error occurs. When simulated, the circuit produces the following graph:

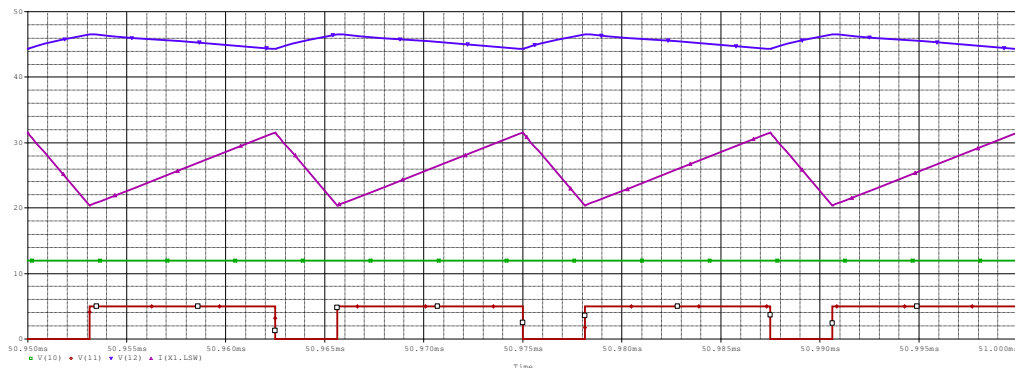

Figure 18: Basic DC-DC boost converter model result

The red line is the voltage source V2, which controls the simulated MOSFET switch. The green line is the input voltage at 12V. The purple line is the current flowing through the inductor in time, and

the blue/purple line at the top is the output voltage across the capacitor. The circuit successfully produced a near 4x boost with an average of about 312W of power entering the circuit.

5.4 Two-Stage DC-DC Converter

Due to real world circuit losses, a single stage boost converter is not capable of providing the amount of boost required by our design. To make a boost converter design feasible, we created a “two stage” boost converter that was essentially a boost converter followed by a second one. This topology would allow our circuit to achieve the necessary output voltage and current requirements, and thus a model of the circuit was necessary for testing. For these tests, we created the following spice code:

```
TWO STAGE BOOST CONVERTER

.MODEL MOSSWITCH NMOS(KP=50 VTO=2)
.MODEL DIODE D(BV=600 VJ=0.7 IS=.001f
N=0.75 CJO=200p)
.MODEL VIRTUALSWITCH VSWITCH(ROFF=1.2m
ROFF=10MEG VON=3 VOFF=1)
.MODEL VIRTUALSWITCH_2
VSWITCH(ROFF=170m ROFF=1MEG VON=3
VOFF=1)

.SUBCKT BOOSTER_S1 1 2 3 4 ; 1=Power In,
2=PWM In, 3=Output, 4=Ground
LSW 1 5 5u IC=0 ; Switching Inductor
RLSW 5 6 8m
RMSW 6 7 1n
SMSW 7 4 2 0 VIRTUALSWITCH
D1 6 3 DIODE
X1 7 4 SNUBBER
X2 6 3 SNUBBER
C1 3 4 47u IC=0 ; Filter Cap
.ENDS

.SUBCKT BOOSTER_S2 1 2 3 4 ; 1=Power In,
2=PWM In, 3=Output, 4=Ground
LSW 1 5 100u IC=0 ; Switching Inductor
RLSW 5 6 37m
RMSW 6 7 1n
SMSW 7 4 2 0 VIRTUALSWITCH_2
D1 6 3 DIODE
X1 7 4 SNUBBER
X2 6 3 SNUBBER
C1 3 4 10u IC=0 ; Filter Cap
.ENDS

.SUBCKT BATTERY 1 2
V1 1 10 12
Rs 10 2 7m
.ENDS

X5 10 0 BATTERY
;V1 10 0 12
V2 11 0 PULSE(0 5 3123n 1n 1n 9.375u 12.5u)
X1 10 11 12 0 BOOSTER_S1
X2 12 11 13 0 BOOSTER_S2
RL 13 0 107

.SUBCKT SNUBBER 20 21
R1 20 22 1MEG
C1 22 21 .01n IC=0
.ENDS

.PROBE
.TRAN 40u 1m 0m 10u UIC
.END
```

This equated to the following visual schematic:

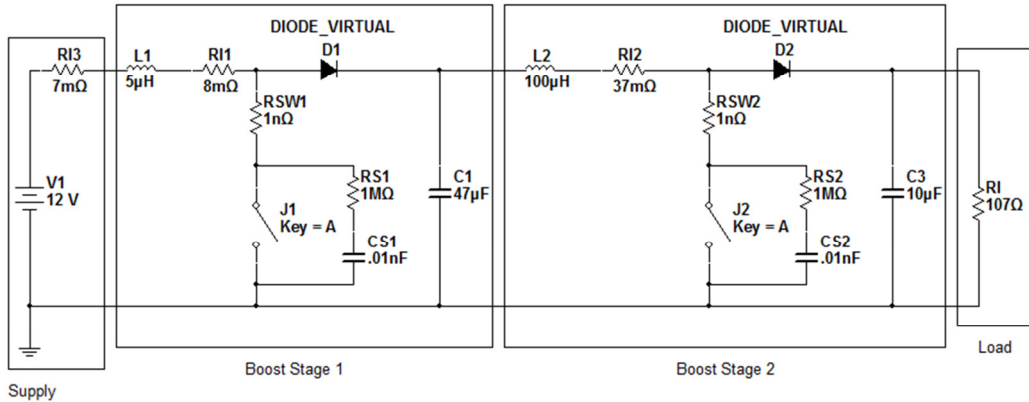

Figure 19: Schematic Diagram of the Two Stage Boost Converter Model

In this schematic, the second boost stage acts like the load for the first boost stage. The output of the entire circuit acts like the load for the second boost stage. The snubbers are not shown for the diodes in this schematic, as well as the source for the switches. Simulating this circuit produced the following graph:

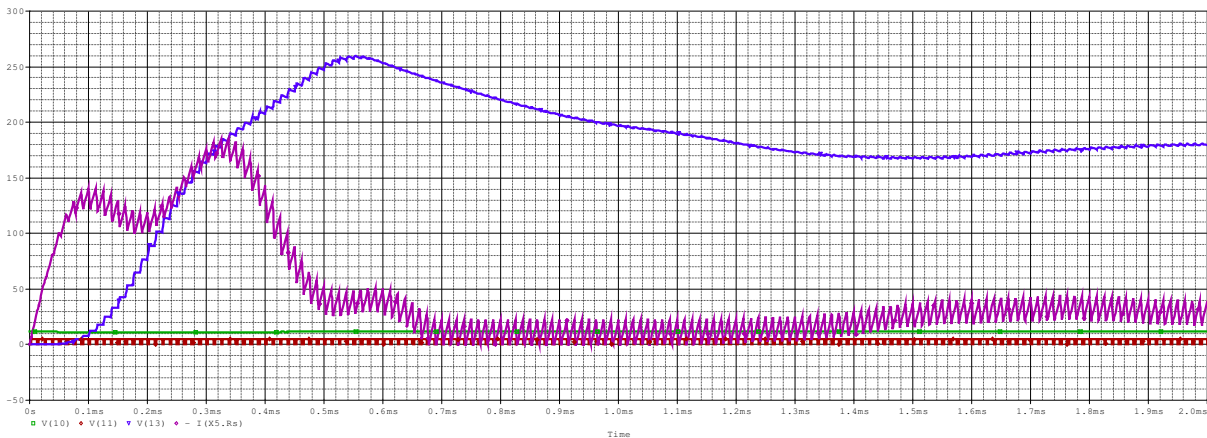

Figure 20: Two stage DC-DC boost converter model result

This graph shows the transient response and settling of the boost converter model. The circuit eventually settled to around 200V at the output while supplying about 300W of power to the load. The transient response isn't very desirable since at one point it wants to draw almost 200A of current, but overall the circuit runs reasonably well.

5.5 V2.2 Prototype primary side

We constructed our original V0 prototype with the mindset that we wanted to see the maximum effects of real world losses, so we intentionally built that prototype with very non-ideal parts and without a simulation so that we could characterize real world losses in the circuit to be able to account for them as much as possible in the next revision. Our V2 prototype was created from the lessons we learned from the V0 prototype, but eventually we ran into some issues on the primary side

of the circuit. We therefore decided to simulate the primary side of the circuit to see if we could find the source of the mysterious characteristics we were seeing. The spice code is as follows:

```

PRIMARY MODEL
.MODEL VIRTUALSWITCH1 VSWITCH(ROFF=1u
ROFF=10MEG VON=5 VOFF=0)
.MODEL VIRTUALSWITCH2 VSWITCH(ROFF=1u
ROFF=10MEG VON=5 VOFF=0)
.SUBCKT SNUBBER 20 21
R1 20 22 62
C1 22 21 10u IC=0
.ENDS
.SUBCKT SNUBBER2 20 21
R1 20 22 62
C1 22 21 10u IC=0
.ENDS
VS 1 0 12
VSW1 11 0 PULSE(0 5 5u 1n 1n 4.5u 10u)
VSW2 12 0 PULSE(0 5 0 1n 1n 4.5u 10u)

RP 1 2 1n
CP 2 0 20u IC=0
LPARA 2 3 10n IC=0
LP1 3 4 8m IC=0
LP2 3 5 8m IC=0
K LP1 LP2 .8
X1 3 4 SNUBBER
X2 3 5 SNUBBER
SM1 4 6 11 0 VIRTUALSWITCH1
SM2 5 7 12 0 VIRTUALSWITCH2
RS1 6 0 4m
RS2 7 0 4m
.PROBE
.TRAN 10u 5m 4.95m 2u UIC
.END

```

This model replicates the primary side of our V2 prototype, with the addition of a small parasitic inductance to the center tap of the transformer. This configuration produces the following graph:

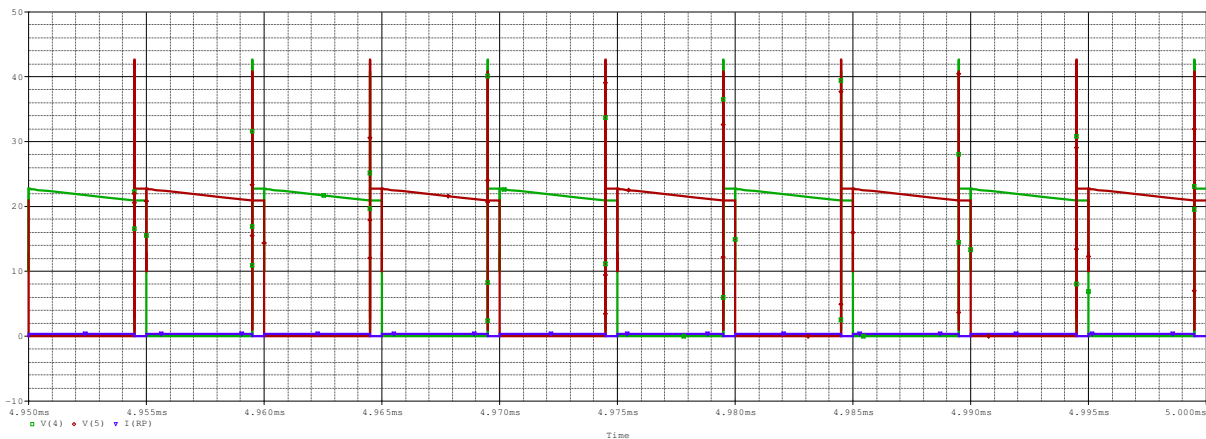

Figure 21: Parasitic circuit elements causing large voltage overshoots

The addition of the more accurate small parasitic inductance to the center tap of the transformer causes a large overshoot of voltage on the drains of the MOSFETs. By adding a small capacitor right in front of the transformer (in this model move CP from 2 0 to 3 0) alters the simulation result:

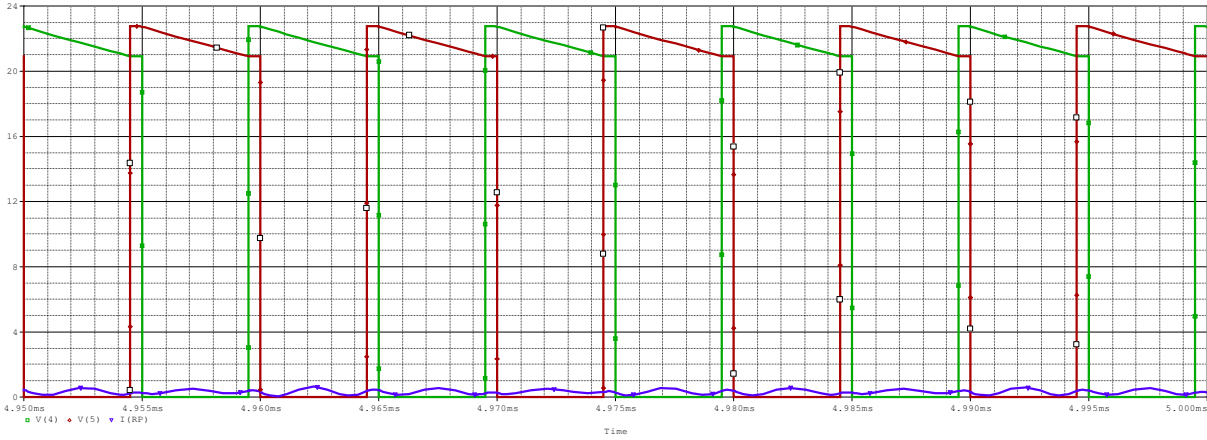

Figure 22: The result of adding a small capacitor to fix the losses from parasitic inductance

The circuit no longer experiences a large voltage across the drains of the MOSFETs with this fix, but at the cost of a small oscillation and extra losses on the input current. To ensure our parts do not experience overvoltage, this is an acceptable compromise.

6 Testing/results

The designs that we created may have worked on paper really well, but thorough testing is necessary for any design to ensure that the system will act reliably and as expected. This section details all of the prototype and final design revisions we made and how they held up to expectations.

6.1 Potential Components

In order to satisfy all of the design requirements, we must include the possibility of using scrap parts harvested from recycled power supplies and inverters. Therefore, our design needs to be flexible enough with the design tolerances to be capable of substituting at least a range of parts that can do each job within the circuit.

The switched mode power MOSFETs used to bias the primary of the transformer can be considered parts where a range of types is acceptable. The necessary requirements for these MOSFETs are that they are able to handle the current capability, the switching speed, and the maximum voltage drop that may be seen across their terminals. Therefore, anything MOSFET that can switch at a speed of 500ns or faster, can handle at least 50V across its terminals, and handle 30 Amps of current may be used to replace the MOSFETs we choose for the final design. The amount of drain source resistance will have to be kept in mind of the person replacing the parts in order to ensure that the MOSFETs don't dump too much power and introduce inefficiency to the circuit, but the amount of inefficiency that is acceptable is up to whoever is doing the replacing.

The transformer core we used in our prototype is actually harvested from an old power supply, so with it we are already proving that the transformer can be made from scrap parts. It is highly likely, however, that whatever transformers/cores found on old supplies will need to be rewound to specification. If done carefully, some of the wire from the old windings could be reused on the "refurbished" transformer, saving some money and resources there. The transformer will need to be retested after being rewound in order to ensure proper operation, but that shouldn't be too much of a problem.

For a brief time, we considered the possibility of the electrolytic capacitors being harvested from the old electronic waste as well. Although it is relatively easy and common to find capacitors that meet or exceed design specification, the capacitors themselves usually do not have a very long shelf life. The problem is that the chemicals that are used as a dielectric in the capacitor eventually eat through the case and cause the part to fail, and it is not uncommon for the capacitors to be the first thing to give out in old parts. Therefore, with much of the capacitors useful time already eaten up by the old system they were in, they should not be reused in new systems because they will not last nearly as long as the other parts in the system. Therefore, all electrolytic capacitors used in this design should be bought new.

The controller chip we use for our design isn't impossible to find in electronic waste. The inverter we bought to study used the same chip probably for the same reasons we did, so although we don't have a good idea of just how common it is to use that part, we find it probable that many power inverters will have at least one inside of them. We don't have the budget to go and buy enough inverters

on the market to try and find a good spread of designs that have them, but field research with the waste products may yield some good results.

Many of the other simple discrete parts may come from recycled parts as well. There are many resistors in our design that can handle a good tolerance of values, and can be taken from electronic waste. The diode bridge on the secondary of the transformer only really needs to be able to handle the current and switch at a speed of at least 500ns or faster, so the diodes are eligible as well.

6.2 V0

This section will describe the first prototype that we constructed to demonstrate that our project could actually achieve DC-DC conversion.

Background

After doing the aforementioned background research into existing inverter designs and the studying of the PV375 we decided to go with a similar design as was in the PV375. Obviously since many of the inverters had the same design there were at least a few good reasons that this design was desirable. The first is its simplicity. The core design consists of a center tap transformer, 2 drive MOSFETs, a full wave rectifier bridge and a filter cap. The most complicated part of this circuit is the drive circuitry and circuit protection design. The second comes from the use of the center tap transformer, using the center tap transformer on the primary side allows for less wire because less turns are required to step up the voltage to the secondary. Exactly how this works will be explained later. Lastly the reason this design is so popular is the price. Given that the core design is so simple for this design the price to build it is less than one that would require more complicated circuitry or different components. The only flaw in this circuit from an initial look is the size and weight. Since it uses a coil that is heavy and has a large profile compared to another design we looked at consisting of two buck converters in series. So jumping ahead with our design we build a rough prototype in the lab from available parts that the ECE shop. Our prototype was named V0 and was constructed on a perf board. The components where roughly spec'd out as V0 was merely a proof of concept design that would demonstrate that this design approach could generate high voltage DC from low voltage DC.

Parts

Here is a parts list of the parts that make up V0 all parts where as close to the required amperage and voltage requirements as was available at the ECE shop.

- 1x perforated board approximately 4"x1.5"
- 2x 330V 200uF electrolytic capacitors
- 4x 1N5408G rectifier diodes
- 2x 25V 220uF electrolytic capacitors
- 1x SN74LS04N - 6 hex inverters
- 2x RFP40N10 N-channel MOSFETs

Design outline

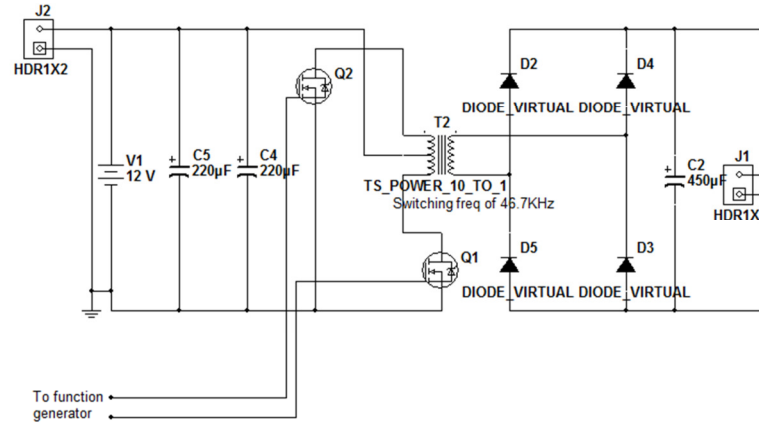

Figure 23: V0 prototype schematic

The picture above shows the core design of V0. The way that the circuit works is by pulsing 12 volts across each leg of the center tap primary. The pulsing is controlled by each MOSFETs and they fire 12 degrees out of phase. When one leg is fired it induces 12 volts into the other leg and thus 24 volts is seen across the outer legs of the center tap. Then since the coil is wound as a 1:10 transformer the transformer should see up to 240V on the secondary side of the coil. The high voltage pulsed DC then run through the 4 diodes that are in a full bridge configuration and then filtered by the 2 capacitors, thus producing high voltage DC on the output with some ripple.

In this design there is no logic to control the MOSFETs switches and the board is powered off of a 12V bench top power supply. The function generator takes the place of the control circuitry and produces the gate drive signal. One MOSFET is connected directly to the function generator and the other is connected through the hex inverter then inverts the signal so that the MOSFETs fires 180degrees out of phase.

Test Results

The results of test this initial designs where labeled as a success but came with mixed results. While we were able to achieve high voltage DC with this design we were only able to achieve 75V. To test V0 we connected the circuit to the lab power supply set to 12V and the function generator set to a 100kHz square wave ranging from 0-5V. We then used to oscilloscope to view the waveforms of V0 under a no load condition. The circuit had significant power loss through the MOSFETs resulting in them heating up significantly and this resulted in only being able to leave the circuit to be powered for seconds at a time. Looking at the oscillograms it proved that the hex inverting that we were using could not source enough current to handle the switching the gate of the MOSFET. So after that realization we instead used the TTL output as well as the regular of the function generator to run each MOSFET gate. The regular output of the function generator was set to 180degrees out of phase with the TTL output and this proved well enough to drive the MOSFET gates.

Even after this fix though our circuit worked better there was still a lot of power being dissipated by the MOSFETs. The cause of this is the fact that the switching waveforms are overlapping and both MOSFETs are trying to conduct. Also looking at the waveforms the voltage across the MOSFETs never reaches 0V. This means that there is resistance in the MOSFETs and thus causing them to dissipate power at the rate of $I^2 \cdot R$. The resistance of the MOSFETs is caused by RDS of the MOSFETs and either it is too high because the MOSFETs is not fully on or because the RDS of the MOSFETs when it is fully on is just too high. When there circuit was running the lab power supply was showing the circuit to be running at 5A and since the RDS of these MOSFETs in the datasheet is 40m Ω the MOSFETs is dissipating $5 \cdot 5 \cdot 40\text{m}\Omega = 1\text{W}$ of power. This was unacceptable because under full load running at 300W the power losses would be $25 \cdot 25 \cdot 40\text{m}\Omega = 25\text{W}!!$ The MOSFETs would instantly burn out.

Another problem noted from the oscillograms was the ringing of the drains of the MOSFETs causing an overshoot. These are caused from the inductance of the coil when the magnetic field of the primary coil collapses and switches polarity.

From these results we concluded that our MOSFETs while able to handle the amperage and voltage of our circuits just had too much internal resistance. So we decided that we needed to change our MOSFETs with ones that had a lot lower RDS. Also we concluded that we had to put in place circuitry that would have “cleaner” switching that would reduce overlap of the MOSFETs and to mitigate the ringing and overshoot of the drains of the MOSFETs.

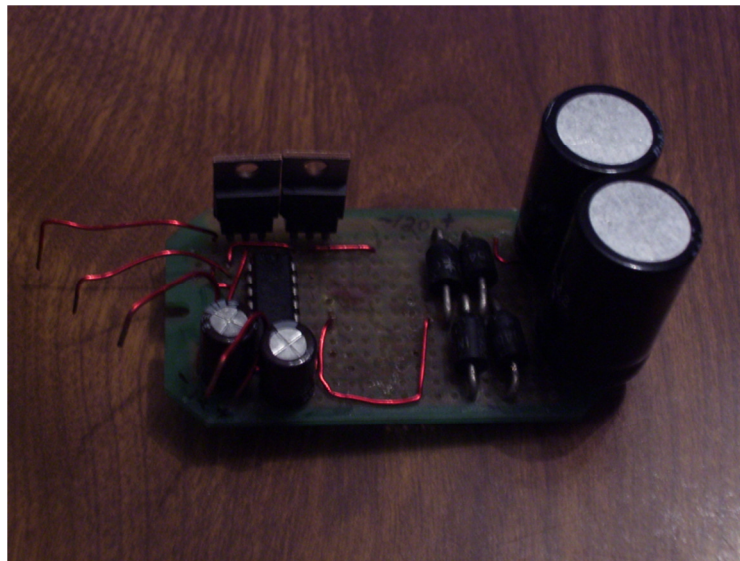

Figure 24: Picture of the V0 prototype

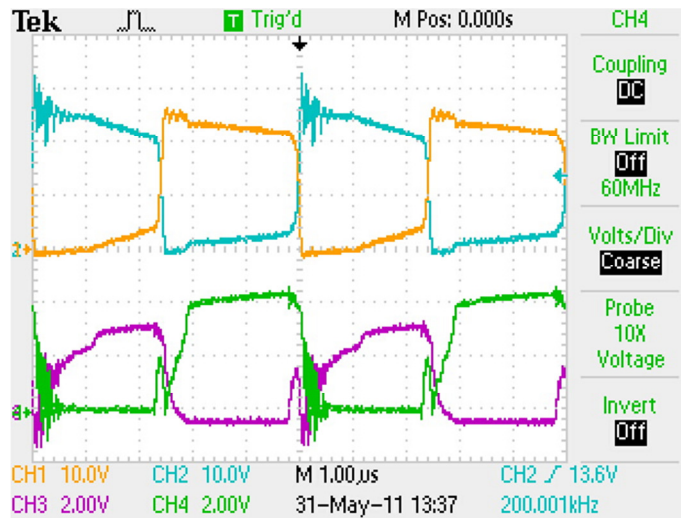

Figure 25: MOSFET Gates and Drains post Hex inverter

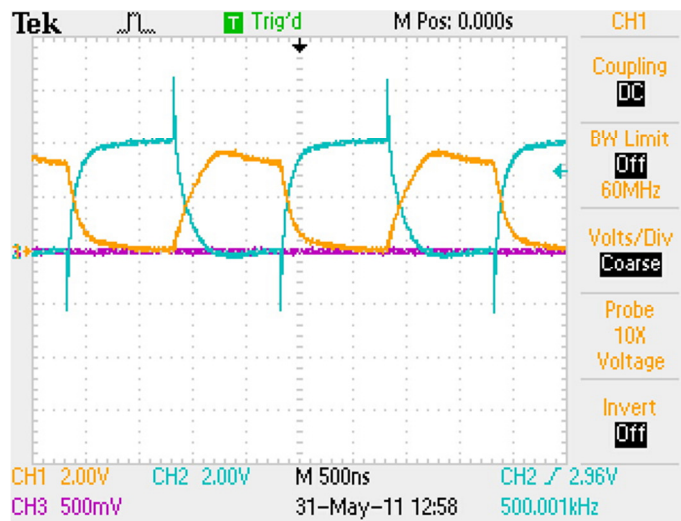

Figure 26: MOSFET gates post hex inverter

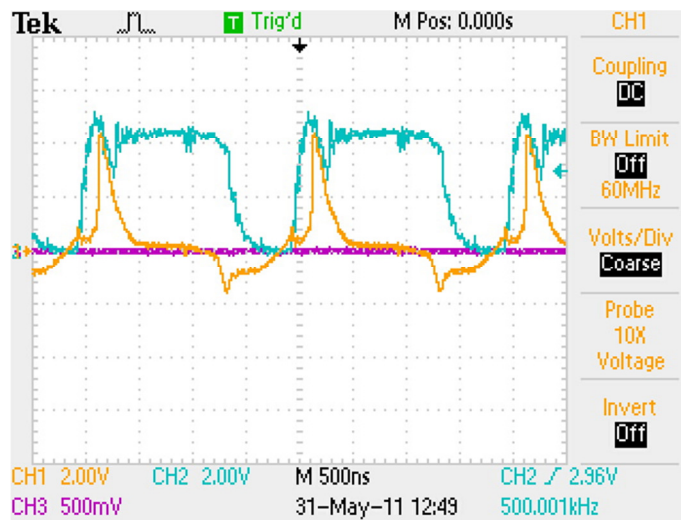

Figure 27: MOSFET gates with hex inverter

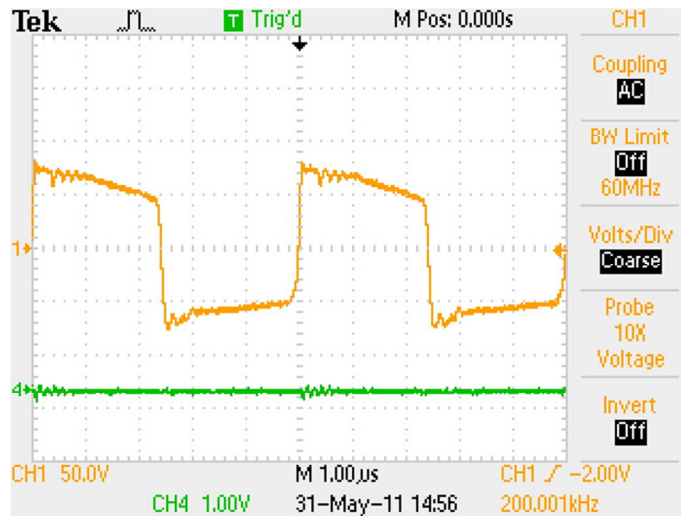

Figure 28: xformer output before bridge post hex inverter

6.3 V2

We revised the original prototype to incorporate improvements to the design to help make the efficiency of the circuit better and reduce the size of the prototype.

Background/Improvements

Before we could continue testing prototypes, we needed to ensure the switching MOSFETs would not overheat themselves. We selected the first pair of MOSFETs from the shop so that we could quickly get a prototype running and see what we could learn from it. These MOSFETs, the RFP40N10, have an internal “on” resistance of 40mΩ, so when the necessary 30 Amps of current runs through them 50% of the time, they are each dissipating an average of 18 watts. This is far too much for our design, both for overall efficiency reasons and the fact that they generate too much heat for us to get rid of. Therefore, we ordered some IRF3205Z’s from Digikey, which only have a fifth of the internal on resistance compared to the original set, cutting efficiency losses and reducing component heating drastically.

Second, we set up a dedicated oscillator circuit on the prototype board instead of running it through an external circuit. The original prototype had problems with trying to get a stable signal to the MOSFET gates in order to switch them properly. This is because at a switching speed of 100KHz, the capacitance effects from long wires combined with the standing wave effects also generated from the standing wave wire lengths made it difficult to get a clean signal through to the gates. We decided to solve both problems simultaneously by moving the oscillator circuit physically closer to the devices it is supposed to operate, and since we would’ve had to contend with a dedicated oscillator anyway for the final design, we decided to do it at this point in the project. We used the same oscillator that we experimented with on a breadboard for our original prototype, and placed it as close to the MOSFET gates as we could.

Third, we added rudimentary “clip on” heat sinks to the switching MOSFETs. We wanted to ensure that even though we had lowered the amount of heat that the devices generated, they still could deal with the amount that would inevitably be generated from load testing. Our final design would also need heat sinks anyway, so from these tests we could also get a reasonable idea of how large of heat sinks we would need in the end.

Fourth, we replaced the diodes in the diode bridge that was connected on the secondary of the transformer with fast switching diodes. Since the device is operating at 100KHz, we wanted to ensure minimal switching losses from all of our components, and the original diodes we chose had a slight amount of lag time on the switching. The new diodes we hoped would remedy that problem.

Finally, we decided to buy a 10:1 transformer from an outside company so that we could see how well the custom transformer that we would stand up to one made by professionals. By comparing the custom transformer’s performance to the new transformer, we hoped to see if the core and materials we chose to build ours with was a smart choice, or if we needed to look elsewhere inside power supplies for the materials we needed for an optimal design.

Parts

Upon purchase of a new perforated board from the ECE shop at WPI, and when the parts were shipped from Digikey, we assembled the new prototype. The parts that we used were:

- 1x perforated board approximately 4”x1.5”
- 2x 330V 200uF electrolytic capacitors
- 4x STTH3L06 rectifier diodes
- 2x 25V 220uF electrolytic capacitors
- 2x IRF3205Z N-channel MOSFETs
- 1x NE555P 555-timer
- 1x 51K Ω 1/4W resistor
- 1x 22K Ω 1/4W resistor
- 1x 25V 100 μ F electrolytic capacitor
- 1x 50V 10 μ F electrolytic capacitor
- 2x 100 Ω 1/4W resistor
- 1x 2N3904 BJT NPN transistor

Design Outline

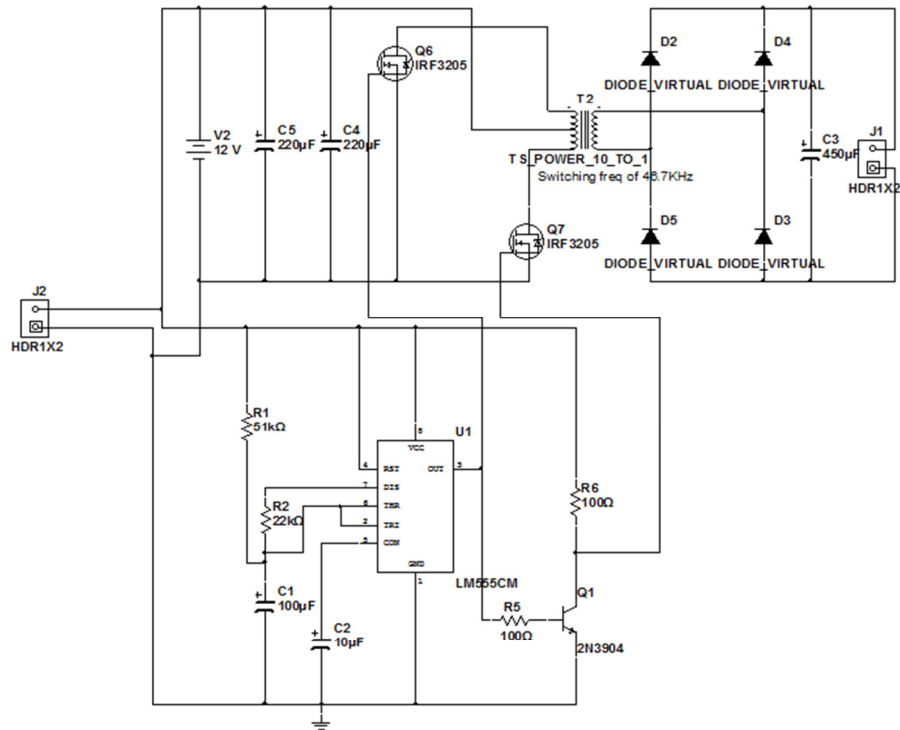

Figure 29: V2 prototype schematic diagram

The core power components run in exactly the same manner as the original prototype, with only optimized components differentiating the two. The main major functional difference between this prototype and the original one is that the circuit has its own dedicated oscillator setup so it doesn't need to rely on an external function generator to provide the switching signal to the MOSFETs. Essentially, pin 3 of the 555 timer acts as the signal source for the two MOSFETs, whose state is governed by the threshold and trigger pins. If those pins see a voltage of greater than $2/3 V_{CC}$, the output drives itself negative and the discharge pin becomes shorted. This discharges the capacitor C1 through R2 until the voltage across it is $1/3 V_{CC}$, where the output drives itself high again, the discharge pin opens and the cycle repeats itself. The selection of components and their placement optimized the circuit to run at a 50% duty cycle and provide a 100kHz square wave signal to the MOSFETs. There is also a simple common emitter amplifier that inverts the signal that runs to the second MOSFET, so that both MOSFETs run while the other one is off.

We took our time during assembly, and were able to connect everything correctly on the first try. We then moved on to test our new prototype.

Test Results

After setting up the test source and measurement devices, we turned on the power to the circuit. Within a few seconds, something was already smoking and we were forced to immediately shut off the power. We investigated the cause of the smoke, and found that our transformer was the problem, and that in the short time it was on it had burned out the internal wires on the primary. We

investigated further and found that our mistake was not in wiring the circuit, but we had made an error looking at the specification sheet. The transformer was rated at enough amperage to do the job, and the turns ratio was correct, but the center tap was on the secondary side of the transformer, not the primary (step down transformer). Therefore, we had connected the high current side of the circuit to the low current side of the transformer, and burned the part. We took the old transformer out of the V0 prototype and put it on the new one so that we could continue testing.

Initial test results were less than what we desired. To illustrate one of the main problems we found, the following is the oscillogram taken from the MOSFET switch drains:

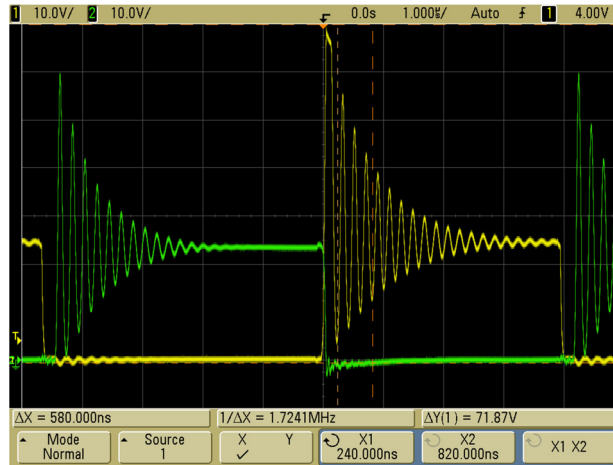

Figure 30: MOSFET drains V2

Ringings and noise were major issues in this prototype. The initial voltage spike on the MOSFET drains easily doubled the steady state amounts that it was supposed to reach. It then continued to oscillate, throughout the entire waveform in the case of Channel 1, until that MOSFET was turned on and therefore lost its resistivity and voltage drop. There are also inherent problems with our oscillator that can be seen from this image as well. There is a significant offset and delay time between the two MOSFETS, and can be seen in the transitions as one MOSFET turns on and the other turns off. Channel 1's voltage overlaps channel 2's when its corresponding MOSFET turns off, but it turns on again well before channel 2's MOSFET on the other transition. Also, the duty cycle between the two MOSFETs are not 50%, since channel 2's MOSFET takes 4.5us of off time while channel 1's MOSFET takes only 4us of off time per cycle. The gates of the MOSFETs also had some ringing on them, as shown in the following oscillogram. However, it had the additional problem of trying to drive the inverted MOSFET straight from the transistor inverter circuit we created, which we had determined would work, but the data clearly shows that the inverter we were using could not source enough current to overcome the RC time constant of the MOSFET gate very well.

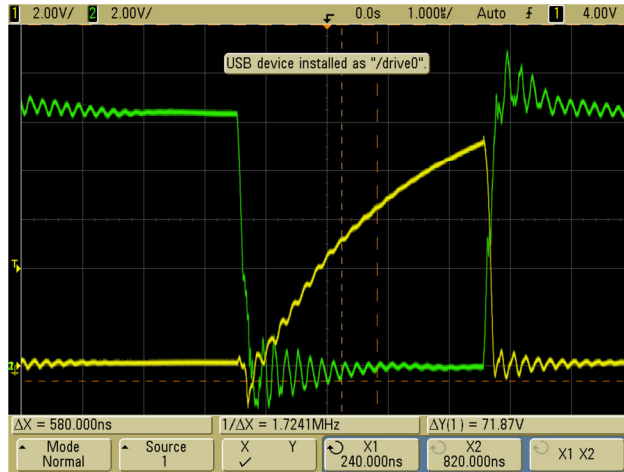

Figure 31: MOSFET gates V2

Because of all these problems, it created heavy losses in the circuit, and the prototype would use more current than our 6A power supply could handle sitting in the idle state. All of that heat would get pushed on to the switches and transformer, and it became apparent that tweaking this prototype to get rid of these problems were necessary.

6.4 V2.1

An improvement to the V2 prototype was constructed from the original V2 prototype instead of building and entirely new one. This upgraded version of the prototype was called V2.1.

Background/Improvements

We decided to adjust the circuit to remove some of the inherent signal problems we were viewing. To accomplish this, we first added a pair of RC snubbers across the transformer to reduce the ringing that was present on the MOSFET drains. Second, we added buffer circuits from the 555 timer and inverter to ensure that the gates were sourced with enough current to switch the MOSFET quickly. Third, we added a small series resistor to each MOSFET gate to reduce the overshoot and ringing present on the MOSFET gates. Fourth, we modified the 555 timer circuit to more closely achieve a 50% duty cycle. Finally, we added zener diodes across the transformer to clamp the voltage in case it became too much for the snubbers to handle.

Parts

- 1x perforated board approximately 4"x1.5"
- 2x 330V 200uF electrolytic capacitors
- 4x STTH3L06 rectifier diodes
- 2x 25V 220uF electrolytic capacitors
- 2x IRF3205Z N-channel MOSFETs
- 1x NE555P 555-timer
- 2x 3KΩ 1/4W resistor

- 2x small signal diodes
- 1x 25V 100 μ F electrolytic capacitor
- 1x .002 μ F capacitor
- 2x 100 Ω 1/4W resistor
- 1x 1K Ω 1/4W resistor
- 2x 2N3904 BJT NPN transistors
- 1x 2n3906 BJT PNP transistors
- 2x 1N5364A 33V 1W zener diodes
- 2x 2.2 Ω 1/4W resistors
- 2x 20K Ω 1/4W resistors
- 2x 500V .01 Ω F capacitor
- 2x 62 Ω 1/4W resistors

Design Outline

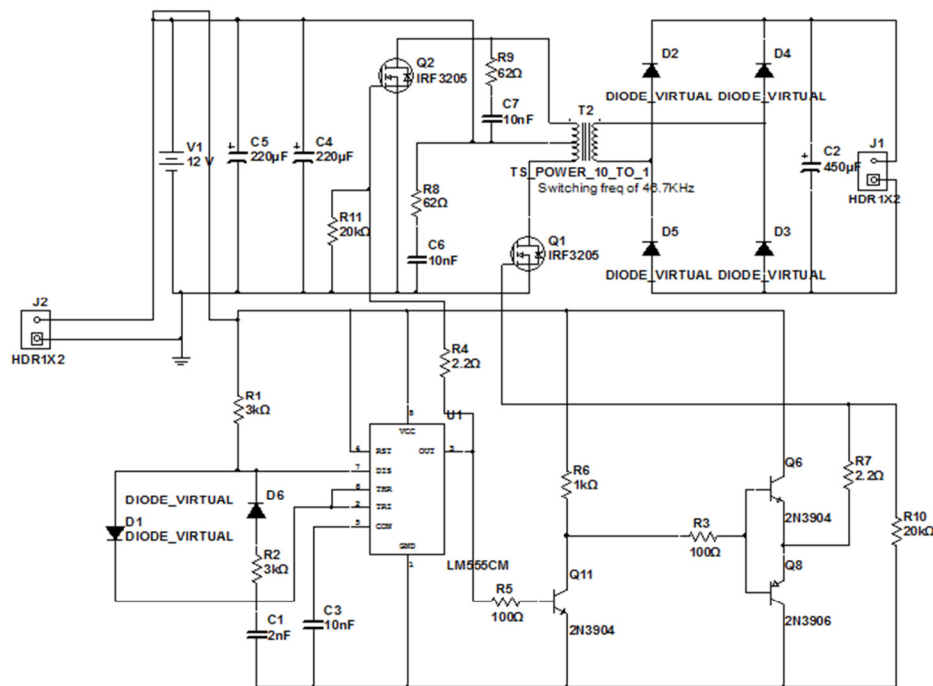

Figure 32: V2.1 Schematic Diagram

The functionality of this circuit is mostly the same compared to the original V2 circuit. There are quite a few small changes that make improvements, though. One improvement is that the resistor capacitor pairs across the transformer's primary legs act as snubber circuits, drastically decreasing the ringing and overshoot that the circuit experiences. This greatly improves efficiency since the MOSFET is not switching between off and on while the current is not supposed to be running through it. The zener clamps across the transformer legs ensure that the MOSFETs are protected from any overshoot that the drains see.

The signal running to the gates of the MOSFETs also see improvements in this circuit. The small resistances in front of the gates help keep oscillations off of those pins considerably by preventing any initial overshoot. The resistors and capacitor that controlled the 555 timer signal have also been modified to take advantage of using diodes to make it easier to control the exact values of components controlling the 555 timer, and ensure that it puts out a signal much closer to a 50% duty cycle than before. The pair of 2N3904 and 2N3906's seen is a class B amplifier that amplifies the maximum amount of current a circuit can produce while minimally affecting voltage. By using this pairs we are able to drive the MOSFET gate connected to the inverter to its maximum and minimum values at a faster rate.

Test Results

It immediately became apparent that the zener clamps we not going to work out as well as we had hoped. The circuit was dissipating too much power through the zener diodes and was burning them just a few short seconds after first power on. We removed the diodes from the circuit and decided to rely on the snubber circuits to limit the ringing by themselves. The new oscillogram taken from the MOSFET drains is as follows:

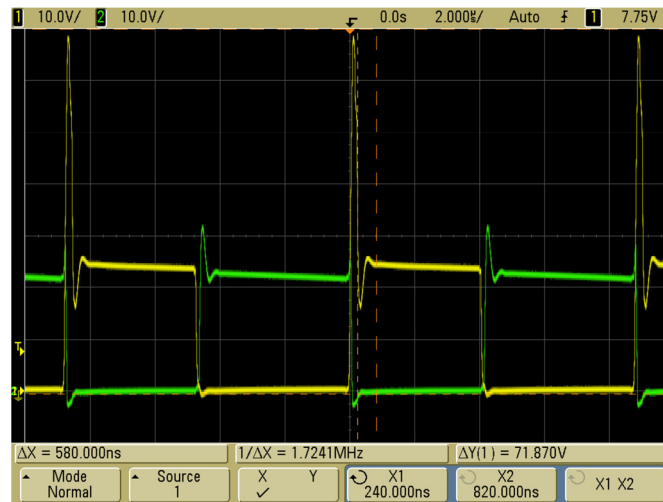

Figure 33: MOSFET Drains V2.1

As can be seen from the oscillogram, the ringing has been tremendously decreased by the circuit alteration. The MOSFET connected to the second channel has also seen a vast decrease of its initial overshoot. The MOSFET connected to channel 1 still as a very large overshoot problem, but its ringing has been largely taken care of as well. Despite the change to the 555 timer circuit, the duty cycle is still not close enough to 50% to make us truly happy with the result. The MOSFET gates have also seen a big improvement in this version:

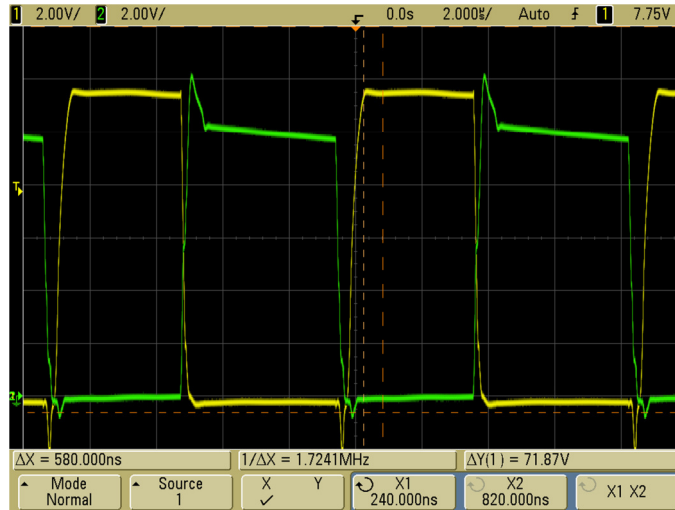

Figure 34: MOSFET gates V2.1

The circuit still draws about 5A idle though, which gets dissipated in various parts of the circuit. The part that receives the most power drop depends on some factors, such as the values of the snubbers. If the snubbers have too low of a resistance, they'll begin to draw power and dissipate a lot of heat. If they are set to the correct value, the MOSFET with the very large ringing problem will then tend to create a lot of heat. Should the 555 timer be slightly adjusted to make it closer to a 50% duty cycle, then the transformer begins to dissipate a lot of heat. After some experimentation with various circuit values, we concluded that the problem was twofold: First, the duty cycle needs to be as close as possible to 50% so that the circuit does not see an average DC value through one of its primary legs, which causes a large increase of heat on that leg's MOSFET. Second, circuit performance was better on the half cycle where there was some dead time between switching, rather than the case where the MOSFETs on times overlapped. After some discussion, we determined that the quickest and easiest path to solving both these problems was to invest in a dedicated control chip to drive the MOSFET gates, eliminating the duty cycle problem and letting us select a user defined dead time simultaneously.

6.5 V2.2

After it became apparent that we were not going to be able to cheaply ensure that the 555 timer produced a 50% duty cycle signal with controlled dead time, we decided to replace it with a dedicated PWM controller. This updated V2 prototype was called V2.2.

Background/Improvements

We purchased an SG3525A control chip from digikey and implemented it into our design. By default, this chip produces an exact 50% duty cycle from its output since it uses a flip flop after its oscillator so that the duty cycle will be a constant 50% so long as the frequency of the oscillator is stable. This chip also has a small amount of dead time even when the resistance between the pins that control the dead time is at zero ohms, which is its lowest setting, so we decided to insert a potentiometer so that we could experiment with what would happen at various dead time settings.

Parts

- 1x perforated board approximately 4"x1.5"
- 2x 330V 200uF electrolytic capacitors
- 4x STTH3L06 rectifier diodes
- 2x 25V 220uF electrolytic capacitors
- 2x IRF3205Z N-channel MOSFETs
- 2x 2.2 Ω 1/4W resistors
- 2x 20K Ω 1/4W resistors
- 3x 500V .01 Ω F capacitor
- 2x 62 Ω 1/4W resistors
- 1x SG3525A PWM controller
- 2x 10K Ω 1/4W resistors
- 1x 2K Ω 1/4W resistor
- 1x 5.1K Ω 1/4W resistor
- 1x 1K Ω potentiometer
- 1x .001 μ F capacitor
- 1x 100pF capacitor

Design Outline

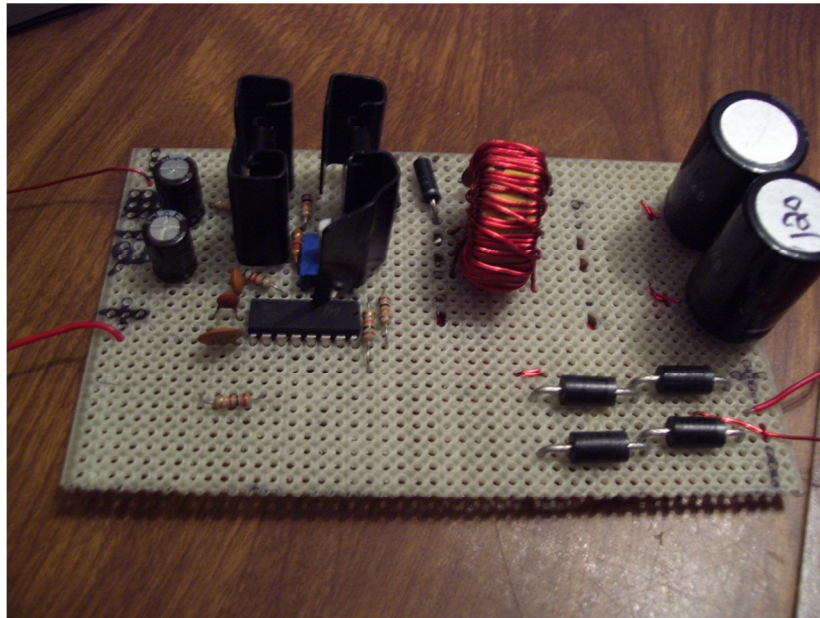

Figure 35: Picture of the V2.2 prototype

The circuit changes from the previous version were solely isolated to the signal generation circuit. The various pins on the chip need to be biased properly for the internal functions of the chip to work. We came up with our design after thoroughly examining the application notes section of the chip's datasheet and looking at various completed design schematics on the internet to figure out how exactly the chip works. The capacitor and resistor values were selected so that the circuit would produce

a 100kHz square wave with 50% duty cycle, and the potentiometer can adjust the duty cycle on the output pins.

Test Results

As soon as we completed the circuit, we immediately began doing test measurements on the design.

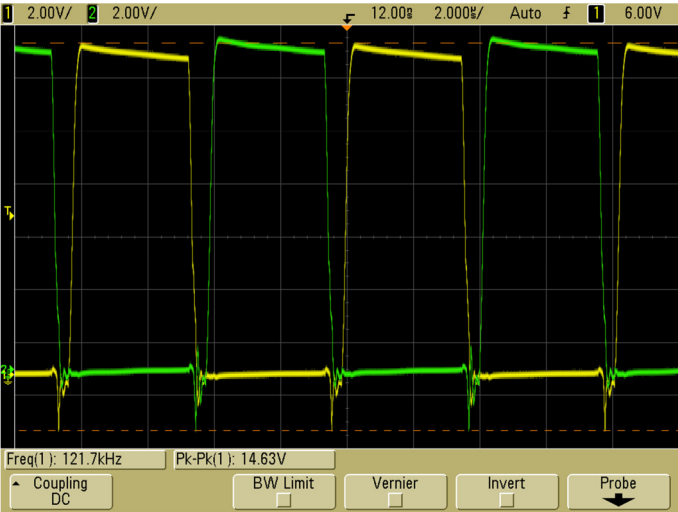

Figure 36: V2.2 MOSFET gates signal

The MOSFET gates have a much cleaner signal running to them. There is now a clear 50% duty cycle, with a small amount of dead time, and both gates are driven all the way up to 12V.

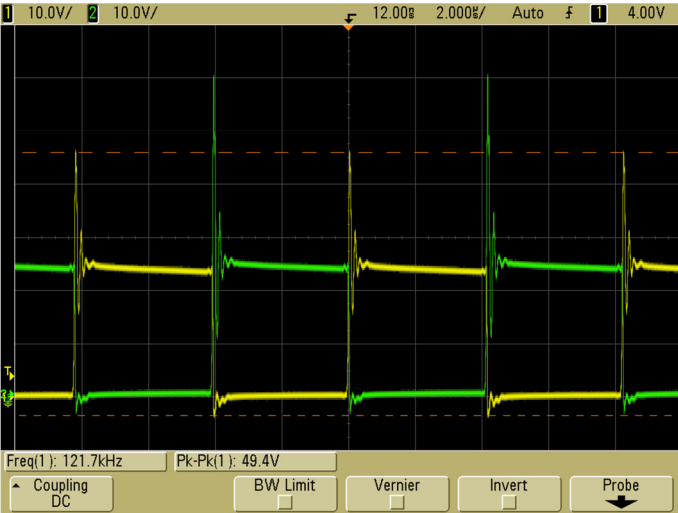

Figure 37: V2.2 MOSFET drains voltage characteristic

The MOSFET drains still have an initial voltage spike, but the rest of the signal looks fairly good. However, the MOSFET connected to channel 2 has spikes above the rated 55V of the MOSFET. Since they're instantaneous, they don't create too much of a problem, but it still is undesirable circuit operation, since those spikes carry over to the secondary of the transformer and cause a large voltage across the output.

This version of the circuit works much better than previous iterations. It draws an average of .5A at no load and none of the components heat up in such a manner that a heat sink wouldn't take care of all excess heat. It has become apparent that in the end a heat sink for the transformer will also be required, but that isn't a very big deal since it is such a small component we couldn't expect it to handle 30A through it without one anyway.

6.6 Coil testing

The heart of our design, the transformer, received some additional testing by itself near the end of the project. We wanted to experiment with various ways to try and improve coil performance. First, we collected data corresponding to the amount of gain the coil produces at various frequencies, which directly corresponds to the efficiency of the transformer (ideally a gain of 10). Here we used the term "gain" referring to the ratio of output voltage to input voltage of the transformer, although it is not typically used in this situation.

frequency(kHz)	Vout(V pkpk)	Vin(mV pkpk)	Gain
20.00	1.58	188	8.40
30.00	2.32	286	8.11
40.00	3.08	388	7.94
50.00	3.84	480	8.00
60.00	4.60	572	8.04
70.00	5.40	668	8.08
80.00	6.12	764	8.01
90.00	6.88	864	7.96
100.00	7.52	960	7.83
125.00	9.36	1180	7.93
150.00	11.20	1410	7.94
175.00	13.40	1600	8.38
200.00	15.00	1820	8.24
250.00	18.20	2220	8.20
300.00	21.40	2620	8.17
400.00	27.60	3340	8.26
500.00	33.20	4040	8.22
600.00	38.00	4560	8.33
800.00	46.80	5720	8.18
1000.00	54.00	6480	8.33

Table 2: Coil Testing

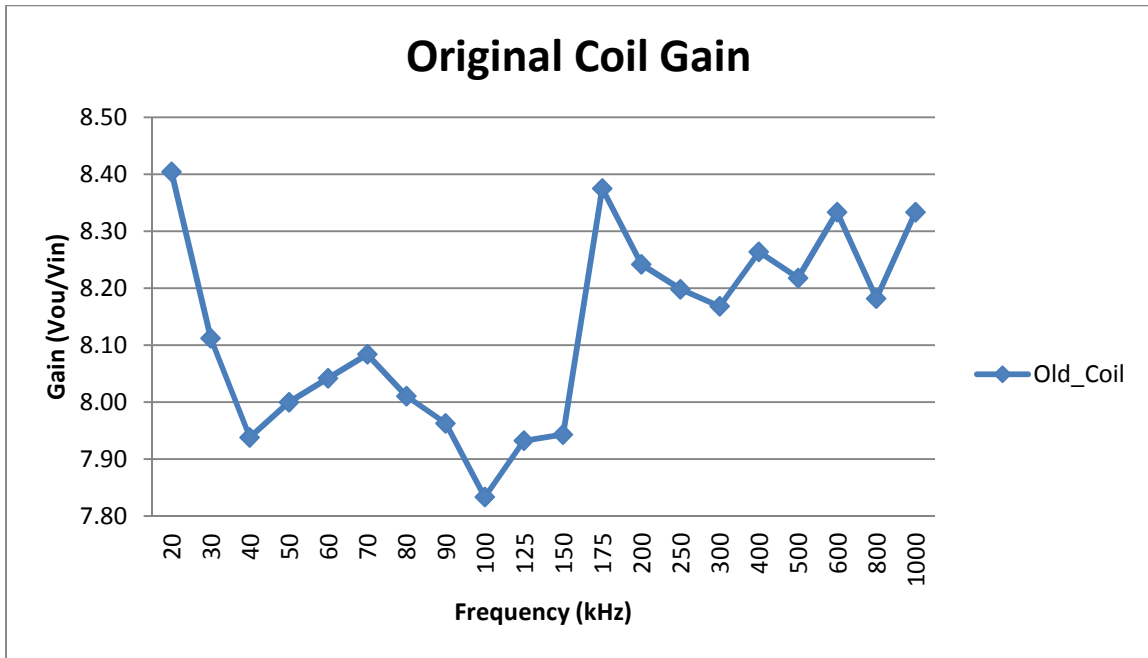

Figure 38: Original Coil's Frequency Response

We originally based our design frequency on what we thought would give us a good tradeoff between switching losses to ripple on the output of the system. However, we see from this graph that we accidentally picked the worst possible spot for the transformer's efficiency between 20KHz and 1MHz. Regardless, we rewound our coil to double the number of windings, while keeping the turns ratio the same to see if the efficiency was significantly affected by this. To save time, we drastically reduced the number of test points we took to just try and measure the general curve.

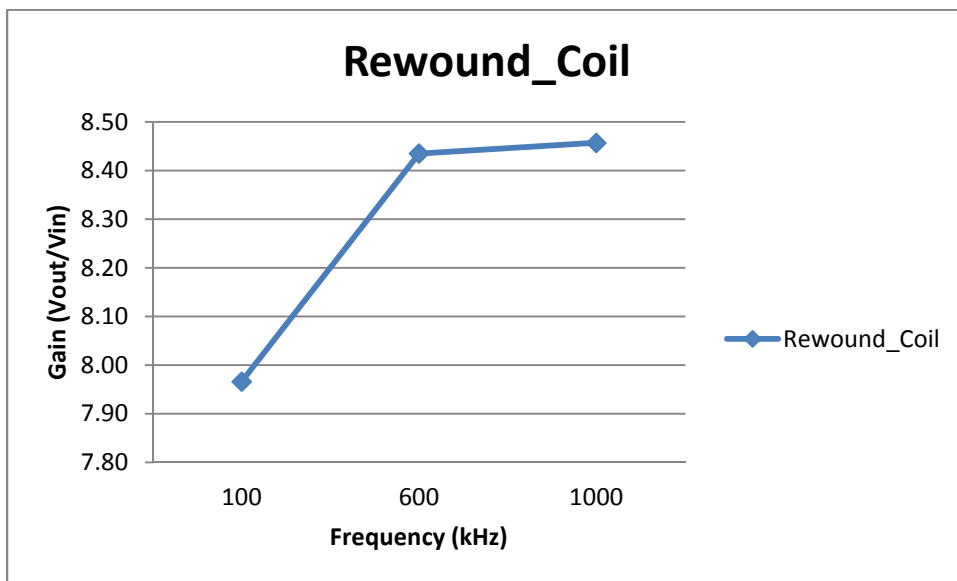

Figure 39: Rewound Coil's Frequency Response

The newly rewound coil seems to perform identically to the original coil, so our experiment ended with the conclusion that the only reasonable way we could improve our transformer's efficiency was to change the ferrite core material used. It is worth noting that the transformer now has more material through which to dissipate heat, so it may show better heat characteristics than before.

7 Future Work/Improvements

As the motto goes “There is always room for improvements”, such holds true even for our project. While our project satisfies the design requirements, there are aspects of it that could be improved upon from a functional standpoint. While perhaps our design is better for the inverter that Waste to Watts had in mind which was simple and cheap, a more efficient design could be made that would be more expensive. This more expensive model would more than likely be better suited for a wider range of applications as efficiency mean a cheaper running cost for the user.

Improvements that can be made to our design fall under three main categories safety, efficiency and functionality. First safety allows our design to be safer for the end user in different circumstances in cases such as of overloading, reverse polarity, power surges etc. Secondly category is efficiency which makes the operating costs for the end user cheaper because less power consumption. The third and final category is more functionality for the user which would make our design more appealing.

7.1 Safety

So first things first, is the design improvements to make our design safer. Obviously safety is a concern to many people from the people who might sell a product with our design in it to the people who use a product with our design in it. Also there are many safety standards out there both in the US and Europe that in order to be certified for must pass testing and such.

As of yet our design does not contain any measures to address basic safety concerns. Such concerns are overvoltage, reverse voltage, over loading, power surges, and overheating. Circuitry can be designed to address each of these.

A simple circuit that might be implemented to address overloading, reverse polarity, and over voltage all in one might be a fuse and diode at the input of the circuit. This is the way Tripplite did it in their circuit (see figure 34). The fuse prevents the circuit from drawing too much power and the reverse bias diode in parallel is forward bias if the polarity is reverse thus creating a short and blowing the fuse. Overvoltage protection may be obtained from this circuit if the diode in reverse bias diode has a breakdown voltage close to that of the circuits operating voltage which will cause the diode to again cause a short that blows the fuse. However better circuitry might be introduced that is not so “fuse-centric” that act more like automatic circuit breakers that blow when one of the conditions above happen and reset itself when the condition goes away. This might be better for the user so that they do not have to keep replacing fuses when these conditions happen.

There are other safety factors as mentioned before that is covered by safety standards such as shock proofing a device. These almost maybe implemented as part of a redesign of our circuit.

7.2 Efficiency

To increase efficiency the first change that could be made is to make the scheme switching more efficient. There are two main improvements that fall under this category. One is to completely get rid of the ringing on the MOSFETs drains. This could be achieved by a better engineered snubber circuit as well as improving the switching circuit for the MOSFETs gates. A better engineered snubber circuit could also implement some form of energy recovery. This would allow some of the energy in the ringing to be put

back into the circuit rather than to be wasted as heat in the snubber resistor. By doing this the efficiency of the circuit would be increased.

Another efficiency increase could be found that falls under the switching category would be to implement a “smart” switching circuit. This would allow feedback from the output of the circuit to control the switching of the MOSFETs so that they only switch when needed and as much as needed. This would be a huge increase in efficiency. This is true because our circuit eats up about an amp of current just sitting there under no load conditions. If the MOSFETs only switched such that the capacitors on the output were charged to their full potential and then the switching stopped until a load was put on, this would stop that one amp of continuous current. Also by only switching as much as needed like in short bursts or perhaps different frequencies the existing switching losses of which can never be zero will occur less often. By the switches switching less in a period of time, reducing the switching losses per unit of time power will be saved.

The great thing about the design of our circuit is that the current controller chip for the MOSFETs is a PWM controller, so to implement the additional changes above for the smart switching requires no change in controller chips just added components to utilize what is already available on that chip.

If in the next design the smart switching is implemented using the existing PWM controller chips the ringing issue may be abated enough that additional snubber circuitry may not be needed at all.

Another change that can further improve the efficiency is a cooling fan. By adding a cooling fan a couple of benefits are added. One is that smaller heat sinks can be used reducing the price and weight of the design. A small fan can be cheaper than a small fan. Also by keeping the circuit cooler the circuit may operate better. This is because as many components heat up their internal resistance rises. Such is the case for resistors, the R_{ds} on MOSFETs and just plain old copper wires/traces and other components. By reducing these resistances it saves energy perhaps enough to justify the power drawn by the fan.

Also by avoiding overheating the MOSFETs to the point of thermal run away will add to the life expectancy of the MOSFETs as well as keep that R_{ds} in check. During thermal runaway the MOSFETs R_{ds} can spike making it dissipate more energy and in some cases burn out.

Another addition to go with the fan could be a temperature sensor that varies the speed of the fan. This can do two things. One it makes the design quieter when not under full load, compared to a fan that’s always on. The second gain from speed control is the decreased power draw from the fan so that the circuit is more efficient.

7.3 Additional Functionality

More is better? Well maybe but the last category additional functionality might be something to be considered for future work. The end user of this circuit might want some built in features helpful to them. For instance if our circuit is used as part of a UPS design it would be more than likely be powered by batteries. So certain features that could be incorporated would be low voltage battery alarm or indicator light and a low voltage shutdown. These could be useful so that the user does not completely

drain their battery. For instance if they use a non deep cycle battery repeated complete discharge will render the battery junk.

To implement such changes could involve a microprocessor for the digital approach or op-amps for the analog approach. Either way the battery voltage on the input could be monitored and depending on its value if the voltage is detected to be too low the low battery indicator or LED could light up. Then if the battery voltage is really low the microcontroller or op-amp could use the shutdown pin of the PWM controller chip for the MOSFETs to shut the whole thing down.

Furthermore to prevent the rapid cycling on and off when the voltage approaches the limits set for the low voltage alarm/indicator and the low voltage shutdown the use of hysteresis should be used. The microprocessor could achieve this by code and for the analog approach a Schmitt trigger could be used.

7.4 Conclusion

So all in all there are a lot of different things that could be improved upon in our circuit. First and foremost is safety it is something that if our circuit is going to be used at all has to be added. The second depending partially on the application of our DC-DC converter is the efficiency. It should be improved as much as possible without increasing the cost of our design. Lastly is additional functionality, and this largely depends on how our circuit is to be used. Certain additions might want to be made for our circuit to be better suited for its use.

8 Conclusion

The 300W DC-DC converter designed in this project while not a novel idea and perhaps considered trivial for a seasoned engineer, it allowed our group to learn a great deal about the engineering process and how to logically step through and solve an engineering problem. Since this was the first time for a large project to go from a problem to an engineered solution. We encounter road blocks and engineering hurdles during our design process. These problems taught us how to take the tools that we have been learning at WPI during our academic career and how to apply them properly to best solve the problem at hand. For as most know it takes the right tool for the right job used properly to of any use to the user.

From the process of lab testing, to computer simulations, down to just figuring where problems in a circuit are that are causing inefficiencies, these are the fine skills not learned in a college classroom. They are so vital to an engineer and this is what this project allowed us to learn and of course your advisor was always there to prod us in the correct direction when we strayed the path.

One example of a design hurdle that we had to overcome was the excessive heating of our driving MOSFETs because of energy dissipation. We had a circuit that worked, it boosted the voltage from the 12V to almost 200V DC but while just sitting there under no load the MOSFETs were almost burning up after a few seconds of being on. So we had to think why is that? What did we not account for? What are we missing? So we go back to what we learned in the classroom how does a MOSFETs work? We are using it as a switch and a perfect switch it is supposed to open and close instantaneously. It should also have infinite resistance when it is off and zero resistance when it is on. However MOSFETs are not perfect switches. MOSFETs by their very nature take time to transition on and off and always have some on resistance referred to as t_{PLH} t_{PHL} and R_{DS} respectively. These characteristics are described in the datasheet for the MOSFETs we choose we consulted the datasheet as well as took oscillograms to look at the MOSFETs operation. After some observations, calculations and such we concluded that our MOSFETs switching time was not the problem. There was some switching losses but not enough to have the problems that we were seeing but it was the turn on resistance R_{DS} . Even though the R_{DS} was small on the MOSFETs the I^2R losses through it were huge up around 2W! So we had to find MOSFETs that had a lot less R_{DS} so they would not dissipate so much power.

This was a small fact just one characteristic in a part among dozens that need to be accounted for. In our initial search for MOSFETs we looked at the voltage, current, switching speed and price of the MOSFETs forgetting the R_{DS} . We paid the price for our fault and we ended up spending time rectifying it.

So in the end we came up with a design that met the requirements laid down at the beginning of the project. However just as any engineer knows there is always some way a design can be improved. So while our design is a good initial design, future iterations can improve the design. However the skills learned and the lessons learned from this project on how to engineer will stay with my group now forever as we go down the path of becoming a seasoned engineer.

9 Appendix A

Old Coil			
frequency(kHz)	Vout(V pkpk)	Vin(mV pkpk)	Gain
20	1.58	188	8.40
30	2.32	286	8.11
40	3.08	388	7.94
50	3.84	480	8.00
60	4.60	572	8.04
70	5.40	668	8.08
80	6.12	764	8.01
90	6.88	864	7.96
100	7.52	960	7.83
125	9.36	1180	7.93
150	11.20	1410	7.94
175	13.40	1600	8.38
200	15.00	1820	8.24
250	18.20	2220	8.20
300	21.40	2620	8.17
400	27.60	3340	8.26
500	33.20	4040	8.22
600	38.00	4560	8.33
800	46.80	5720	8.18
1000	54.00	6480	8.33

Table 3: Old Coil Data

Rewound Coil			
frequency(kHz)	Vout(V pkpk)	Vin(mV pkpk)	Gain
100	7.52	944	7.97
600	38.80	4600	8.43
1000	54.80	6480	8.46

Table 4: Rewound Coil Data

10 Appendix B: Waste to Watts

10.1 Company Overview*

Waste to Watts (W2W) commits to creating innovative products from repurposed electronic waste that meets the energy dilemmas of developing economies. The World Bank names energy poverty in developing economies as one of the world's most widespread and debilitating crises, and estimates that the average developing world business or hospital can experience 18 power outages in a single month. Business value lost due to power outages exceeds 10% annually in developing economies, draining billions of dollars from these nations and critically damaging quality of life. Concurrently, habitual consumerism and proliferation of cheap electronics continue to drive the disposal of vast quantities of electronics worldwide. 400 million units of environmentally hazardous electronic waste are discarded annually – 87.5% of which ends up in landfills.

Inspired by a summer spent volunteering in Tanzanian hospitals repairing medical equipment, the founders of W2W have designed a proprietary, low-cost, modular back-up power supply that can support a wide range of critical electronic devices for several hours when the power goes out. The device is called the Enzi, which translates to 'powerful' in Swahili. How are costs controlled to make the unit affordable for eager consumers in developing economies? We integrate recycled components from discarded electronic waste to take the place of the most expensive parts of our design.

Waste to Watts offers the first affordable back-up power solution that meets specific needs of consumers in developing countries, and provides the solution in an environmentally beneficial and sustainable process. W2W has deployed a 3rd iteration of its prototype for pre-pilot testing in Rwandan, Cambodian, and Tanzanian hospitals. The company is planning a pilot operation with a non-profit partner in Nicaragua to begin in Q4 of 2011. The e-waste components required to build the device will initially be sourced through contracts with e-cycling companies in the USA, but a primary goal of the pilot operation is to establish connections to local electronic waste streams to provide local environmental impact and decrease supply chain overhead.

Management & Advisory Team

The Waste to Watts leadership team is composed of James Molini (Georgia Tech–B.S. Biomedical Engineering), Chris Hamman (Duke University–M.S. Engineering Management/WPI–M.S. Electrical Engineering), Patrick Caputo (Georgia Tech–Ph.D. candidate in Electrical and Computer Engineering), and Jennifer Blanco (MPP-University of Chicago). The multi-disciplinary team has professional experience in outside sales, product development, project management, corporate social responsibility, non-profit sector, as well as work experience in developing countries.

The advisory panel includes Dr. Lawrence Fryda, an international technology consultant to developing world nations, Sid Rupani, a Ph.D. from MIT specializing in process optimization research, Fernando Gonzalez, former regional CFO of AES Corp. and ContourGlobal, Tom Lynch IV, a serial entrepreneur who has founded three companies, Mark Seal, a former operations & supply chain chief executive, and Eben Armstrong, a biomedical engineer with hospital and device experience in over 30 developing world countries.

Logic Model

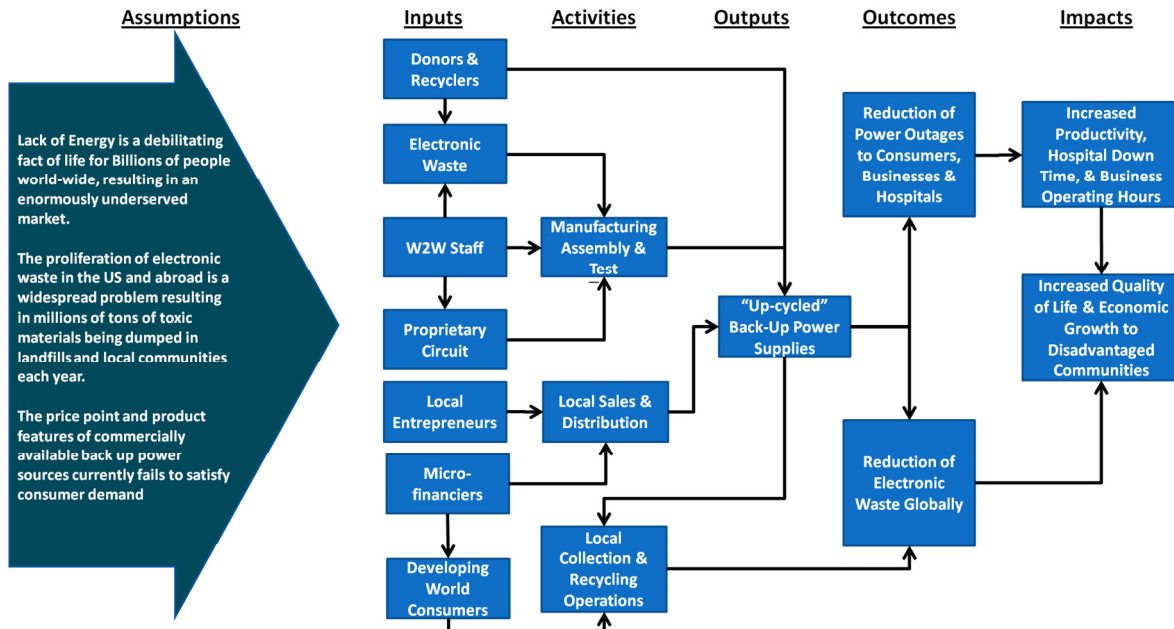

Figure 41: Waste to Watts Kellogg Foundation Logic Model

Above is a visual representation of the founding idea behind Waste to Watts and how it intends on interweaving its business successfully into the existing fabric of local economies around the world as well as the positive impacts that it hopes to have.

10.2 Business Description and Vision

Imagine yourself at the hospital bed of a loved one. Doctors and nurses have rushed in to resuscitate them. Their life hangs in the balance, not because of a device malfunction or health complication, but a power outage. As discovered by Waste to Watts' founders, these tragedies are harrowing truths every day for many citizens in developing countries.

The inception of Waste to Watts LLC (W2W) occurred in the summer of 2009 after the founders met while volunteering as medical equipment technicians in Tanzania as a part of the Duke University-Engineering World Health Summer Institute. While repairing medical equipment in several hospitals, it quickly became evident that the disparity between the reliability of power in developing countries and OECD (Organization for Economic Co-operation and Development) nations was a crucial factor contributing to problems in local economic productivity and quality of life. After analyzing the present market for reliable back-up power products in developing economies, cost-effectiveness arose as the most critical metric by which to evaluate product viability in the target environment. W2W concluded that utilizing discarded, yet still functioning, electronic waste components to build a product would not only meet the primary goal of limiting cost but would also provide an accessory benefit of creating a vehicle to curb the proliferation of environmentally hazardous electronic waste. The need for a low-cost solution that could mitigate losses due to power outages drove the founders to build a first prototype of W2W's flagship product on-site in Karatu, Tanzania.

W2W's first product offering is the Enzi (meaning "powerful" in Swahili): a low-cost, modular uninterruptible power supply (UPS) that cuts manufacturing costs by utilizing repurposed electronic waste to replace expensive components. The proprietary technology is composed of a combination of recycled electronic waste components interfaced with an inexpensive custom circuit interface that includes a battery charger and a pulsed desulfator component. By incorporating electronic waste components that can be sourced in the developing world, the Enzi cuts costs yet can still exceed the run times of commercial UPS units while at the same time combating the proliferation of electronic waste in local communities. Waste to Watts aspires to be a pioneer in not only alleviating developing world energy poverty but establishing sustainable recycling initiatives in emerging markets.

Waste to Watts is a for-profit Limited Liability Company based in Atlanta, Georgia. W2W's mission is to create innovative products from repurposed electronic waste to meet the growing energy demands of the developing world. W2W commits to following the triple bottom line (3BL) standard of People, Planet, Profit, adopted by the UN which emphasizes "an expanded spectrum of values for measuring organizational success: economic, ecological, and social".

10.3 Product Description- Enzi

The Enzi is a low-cost solution for developing world customers who lack access to reliable power. For customers with access to the grid the Enzi can be used as an offline uninterruptible power supply (UPS). When grid power is available, it will be filtered and used to power devices attached to the Enzi while also charging the backup battery. When the power goes out or if the line voltage is too low or high to safely power devices, the battery is used to power appliances with the DC/AC inverter built into the Enzi. The switch from grid power to backup power will take a fraction of one power cycle (<12ms), so that the switchover is completely transparent to the user (Fig. 2). The UPS consists of an "E-cycled" component, a new or used lead acid battery, and the Enzi interface, as well as an enclosure for the system. Repurposed "E-cycled" components include a discarded power supply from a consumer electronic device such as a laptop and a used 12V lead acid battery, such as those found in cars, trucks, and motorcycles. A custom circuit that functions as the battery charger, DC/AC inverter, and desulfator completes the system (Fig. 3). The Enzi is able to reclaim some of the lost capacity in used lead acid batteries and prolong the life of new lead acid batteries by utilizing pulsed charging desulfating technology. The Enzi mitigates the effects of sulfation, the primary wear mechanism in lead acid batteries, by sending short bursts of current into the battery, which forces lead sulfate crystals on the lead plates to dissolve thereby reconditioning the battery.

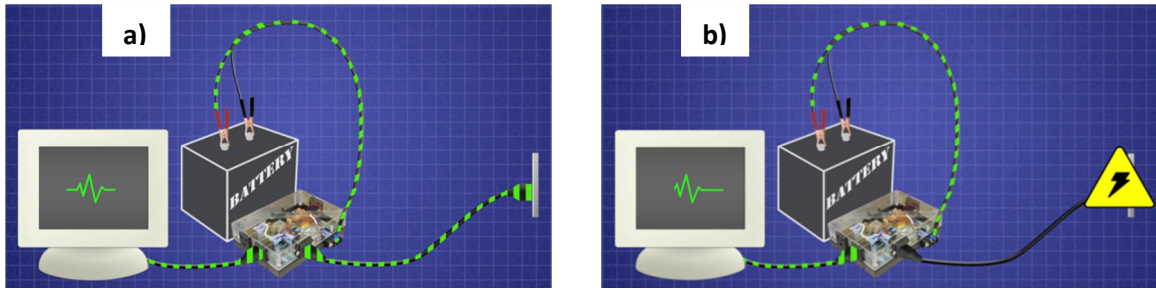

Figure 42: a) Grid power used to charge battery and run the attached device; b) Grid power interruption causes Enzi to go into battery backup mode, where battery power is used to run the attached device

When grid power is unavailable or in locations where outages last many hours, the Enzi can utilize a solar panel to either completely replace or supplement grid power. Solar energy is the most abundant renewable energy source and the Enzi allows customs to take advantage of this endless resource. Waste to Watts has filed for a provisional patent for the design and hired a Patent Attorney to pursue patent and trademark filings. The 3rd generation prototype has been tested in Rwanda, Tanzania, and Cambodia and the 4th generation is currently in development and scheduled to be completed in August 2011.

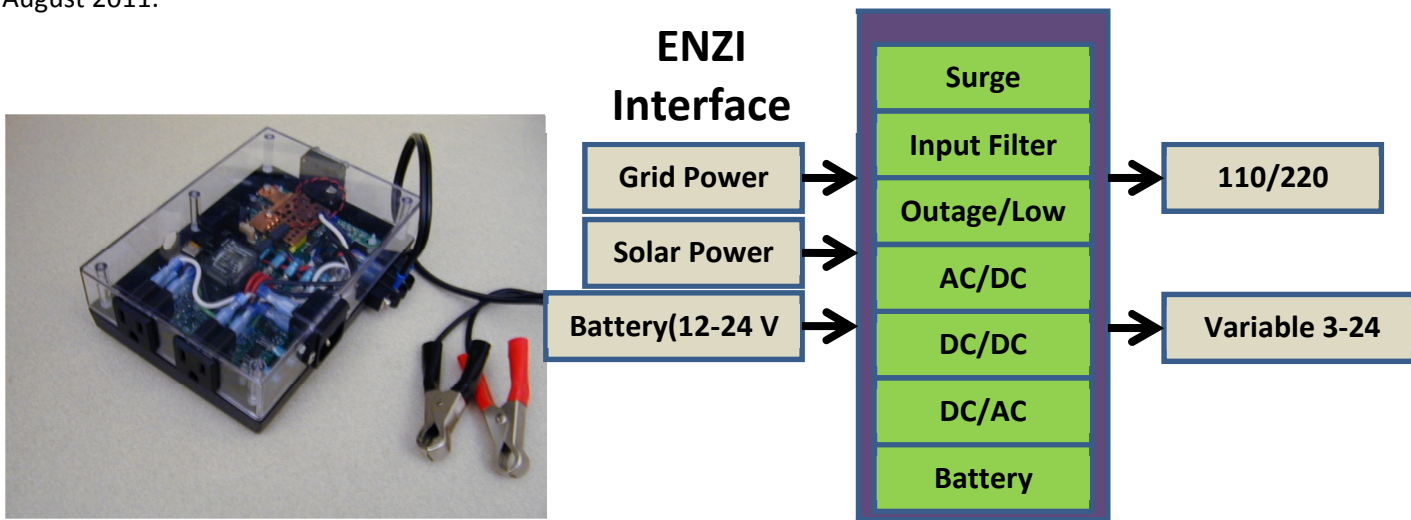

Figure 43: (Left) Picture of 3rd Generation Prototype, (Right) Enzi Functional Block Diagram

11 References

- [1] Hart, Daniel W. *Power Electronics*. New York, NY: McGraw-Hill, 2011. Print.
- [2] Sine, Square, and Modified Sine Waves. Digital image. *SineWaveInverters.info*. 17 Sept. 2010. Web. 31 July 2011. <<http://sinewaveinverter.info/admin-updates/page/2/>>.
- [3] Hart, Daniel W. *Power Electronics*. New York, NY: McGraw-Hill, 2011. Page 220. Print.
- [4] "UL Standards." *UL | UL Standards*. Underwriter Laboratories. Web. 01 Aug. 2011. <<http://www.ul.com/global/eng/pages/corporate/standards/>>.
- [5] Nave, R. "Household Electric Circuits." *Household Electronic Circuits*. Georgia State University. Web. 01 Aug. 2011. <<http://hyperphysics.phy-astr.gsu.edu/hbase/electric/hsehld.html>>.
- [6] "NEMA Plug Receptacle and Configurations." *No Outage.com LLC*. 16, Jul. 2011. Web. 01 Aug. 2011. <http://www.nooutage.com/nema_configurations.htm>
- [7] "CAN/CSA C22.2 NO. 601.1-M90 (R2005) Medical Electrical Equipment - Part 1: General Requirements for Safety." *TechStreet*. The Thomson Reuters Corporation. Web. 01 Aug. 2011. <http://www.techstreet.com/cgi-bin/detail?doc_no=can_csa|c22_2_no_601_1_m90_r2005_;product_id=944303>
- [8] "FCC Part 15." *Communication Certification Laboratory*. Nemko-CCL Inc. Web. 01 Aug. 2011. <<http://www.cclab.com/fcc-part-15.htm>>.
- *All information in the Waste to Watts section was information directly given to us from Waste to Watts LLC.