



Evaluating the Role of Stormwater Treatment Basins in Controlling Highway Runoff Quality

A Major Qualifying Project Report

Submitted to the Faculty of

Worcester Polytechnic Institute

In partial fulfillment of the Requirements for the

Degree of Bachelor of Science

March 3rd, 2017

Elizabeth Desjardins, Julia Scott and Anna Valdez

Advisors: Professor Paul Mathisen and Professor Suzanne LePage

This report represents work of WPI undergraduate students submitted to the faculty as evidence of a degree requirement. WPI routinely publishes these reports on its web site without editorial or peer review. For more information about the projects program at WPI, see

<http://www.wpi.edu/Academics/Projects>

Abstract

The goal of this project was to understand the function and effectiveness of stormwater treatment basins in removing contaminants from highway runoff in the Wachusett Watershed. Fieldwork and lab analysis of runoff, soil, groundwater and surface water samples were conducted to determine levels of specific conductance, solids, and metals. Additionally, an optimal stormwater basin was designed through modeling and low-cost alternatives were made to the Massachusetts Department of Conservation and Recreation to improve the current basin in place.

Acknowledgements

The project team would like to extend their appreciation and gratitude to the following people for their support and help with the completion of this Major Qualifying Project.

Professor Paul Mathisen

WPI Civil and Environmental Engineering Associate Professor - Project Advisor

Professor Suzanne LePage

WPI Civil and Environmental Engineering Instructor - Project Advisor

Donald Pellegrino

WPI Civil and Environmental Engineering Laboratory Manager

Pat Austin

Massachusetts Department of Conservation and Recreation
Division of Water Supply Protection- Wachusett/Sudbury Section

Daniel Crocker

Massachusetts Department of Conservation and Recreation
Division of Water Supply Protection- Wachusett/Sudbury Section

Steve Sulprizio

Massachusetts Department of Conservation and Recreation
Division of Water Supply Protection- Wachusett/Sudbury Section

Vincent Vignaly

Massachusetts Department of Conservation and Recreation
Division of Water Supply Protection- Wachusett/Sudbury Section

Anne Bastoni

Massachusetts Department of Transportation- Highway Division Environmental Services Section

William Clougherty

Massachusetts Department of Transportation- Highway Division District 4 Project Design
Section

Capstone Design

The Major Qualifying Project (MQP) for the Environmental Engineering Major at Worcester Polytechnic Institute is required to have a Capstone Design as part of the final project deliverable. To meet this requirement for the project, an optimal design and alternative recommendations were given to the sponsor, the Department of Conservation and Recreation (DCR), for a basin adjacent to Interstate 190 (I-190) in the Wachusett Watershed. The project selected one basin and analyzed its function and efficiency of trapping pollutants. Through gaining a better understanding of the basins, an optimal design was developed which could be implemented for multiple basins in the I-190 region of the watershed. The Accreditation Board for Engineering and Technology requires that students graduate with the documented ability to "design a system, component, or process to meet desired needs within realistic constraints." To meet this requirement the design considered impacts of the following factors: environmental, constructability, sustainability, economic, social, and health and safety.

Environmental

The environmental impacts of this project were considered in Chapter 5 Recommendations / Design of this report. The recommendations focused on improving efficiency of the basin. By improving the basin's ability to capture sediments and contaminants associated with runoff from I-190, the project helped to improve water quality in the Wachusett Watershed. Additionally, it is especially important if there were to be a toxic spill on I-190 that the basin would be able to contain these hazards.

Constructability

With completion of this project, a list of improvements were provided to the DCR that could be implemented with the support of the MassDOT. Additionally, the construction process of the optimal basin is relatively similar to previous basin construction plans as it aligns with the MassDEP Handbook and MassDOT Handbook standards and can be accomplished with limited difficulties.

Sustainability

The key to a quality product is to be sustainable, needing minimal maintenance and ensuring longevity. Through observation we noticed that the basins often became overgrown with vegetation making them difficult to enter. All recommendations for the basin attempted to minimize required maintenance and increase the life cycle of the basin.

Economic

The equipment and materials that were proposed in our report were not only considered for effectiveness but also cost. The state has a budget they have to work with, therefore improvements had to be selected for best quality with the lowest cost. For each characteristic of

the basin the cost was considered when choosing the details. For example, the optimal basin's outlet structure we replicated the current outlet used in the project basin because it is stable and effective at this site. It is also the most cost effective option even though the MassDOT's recommended design is an outlet pipe. Our team also provided the DCR with a list of additional improvements to allow for upgrades to be made to the basin as funds become available.

Social

The suggested improvements in our report impact the surrounding community of the reservoir and the Boston community that is supplied water from the reservoir. By recommending upgrades to the basin it helped improve the basin's preventative measures of inhibiting contaminants from spreading. Therefore the outflow water will be of higher quality and be less expensive to treat during the water treatment process. Higher water quality improves health for citizens and wildlife affected by the Wachusett Watershed.

Health and Safety

The DCR was concerned with the unknown risk of uncontained contaminants leaching from the basins into the Wachusett Reservoir. By deciding to collect groundwater, runoff, and soil data from several locations our team gathered a broad perspective of what flowed into and out of the basin. With these specific recommendations that improve the efficiency and quality of the basin, the DCR will be able to improve the health and safety of the surrounding community through cleaner drinking water.

Executive Summary

The Wachusett Reservoir provides clean drinking water to the Greater Boston area. The water quality of this reservoir is monitored by the Department of Conservation and Recreation (DCR). One aspect of maintaining high water quality is treating stormwater runoff produced during storms, in particular highway runoff. The region this project focused on was Interstate 190 (I-190) in Sterling, MA. The types of stormwater Best Management Practice (BMP) used in this area are stormwater treatment basins which temporarily store and infiltrate water.

The effects of these basins have not been monitored by the DCR. Therefore the MQP team wanted to develop a better understanding of these basins. The goal of this project was to evaluate the impact of the stormwater basins along I-190 in controlling runoff and develop appropriate recommendations to improve their effectiveness. The steps to accomplish this goal were to select the project basin and understand the impacts of the basin through field and lab work and desktop analysis with ArcGIS and HydroCAD®. The last step was to perform desktop modeling with HydroCAD® and Revit® to develop an optimal design and alternative recommendations for the current BMPs.

Runoff, soil, and groundwater samples were collected between October and December 2016 at the project basin. Additionally, surface water samples were taken at Stillwater River, a nearby tributary of the reservoir. The runoff samples were collected during two storms via a Cipolletti weir constructed by wood and sandbags to create a measureable inlet pool to collect samples. Flow rates were then calculated for these storms. The soil samples were collected with a coring device and a shovel and the groundwater samples were collected with piezometers the team made.

The samples were then analyzed for specific conductance, pH, Total Suspended Solids (TSS), and levels of metals in the WPI Kaven Hall Laboratory. The modeling program HydroCAD® was used to model the hydrology of the project drainage area and project basin. Hydrographs were then created for entirety of the storm events and theoretical storms. The key findings developed from our graphs and data analysis were in regards to metals in the runoff. The two metals that had detectable levels and were able to be easily followed throughout the flow path of the basin were Sodium (Na) and Magnesium (Mg). Na levels stayed consistent throughout the basin and various points of treatment. The groundwater levels near the outflow of the basin were similar to the inlet concentrations. On the other hand, Mg did decrease throughout the basin and had almost negligible levels at the outflow, showing that the basin was effective in trapping some contaminants.

In order to address the areas of the project basin that needed improvement, an optimal BMP was designed. Alternative recommendations were made for the current project basin if the optimal

basin is not feasible. The BMP was designed in compliance with the revised 2008 MA Stormwater Management Standards and the 2017 Draft version of the MassDOT Stormwater Management Design Handbook. The required storage volume was determined to be 51,300 ft³ with dimensions of: 90 W x 95 L x 6H for the infiltration basin. The Simple Dynamic Method and hydrographs were used to determine this sizing and make sure the basin was designed to support storm events up to 100 year storm.

The layout design for the optimal basin begins with a concrete ditch leading to a basin inlet where stormwater runoff from I-190 enters. The runoff will continue through a trash rack into the sediment forebay, where sediments will collect and settle, with runoff pooling until it spills over the check dam. The check dam will then direct the flow of the runoff into the infiltration basin while reducing the flow's velocity. Within the infiltration basin there will be two groundwater testing wells, native vegetation, and a permeable nonwoven geotextile liner below the soil layer. The runoff will continue to settle and infiltrate until it reaches the groundwater. The runoff will then exit the basin via groundwater or the spillway outlet. AutoCAD© and Revit© were used to show the layout, placement, elevations and dimensions of the optimal basin.

While the optimal basin is our recommendation and preferred choice, low cost alternatives could be made to the current basin. These include planting native species, removing existing fences, performing routine maintenance, adding a trash rack to the inlet of the basin, and implementing permanent groundwater testing wells.

This MQP provided the DCR with a greater understanding of the effectiveness of a stormwater treatment basin along I-190 and how runoff is being contained and treated. Future monitoring and extrapolation to the entirety of the BMPs along I-190 would allow for continually improved stormwater management.

Professional Licensure Statement

Professional Engineers (PE) stand for quality, trust, and commitment to their work. The seal of a Professional Engineer represents that high standards and proper safety standards are met for the people and environment their work affects. Having a PE licensure allows private and public employers and clients to trust the work of that engineer. For some firms it is illegal to sign plans without holding onto a PE. Additionally, some universities and other higher education institutions require their teachers to have their PE. The PE has been a symbol of qualified work since its beginning 100 years ago in the state of Colorado (NSPE).

To obtain a PE one must go through a multiple step process. The first step begins with completing four years of education in an accredited engineering program. After graduation, an engineer is expected to pass the Fundamentals of Engineering Exam. Then, once the engineer has completed four years of practice under a licensed PE they can take the Principles and Practice of Engineering Exam. The exam's concentration correlates with the specialty of the engineer. The Environmental Engineering PE exam is eight hours long and addresses the following areas: water, air, solid waste, site assessment and remediation, and environmental health and safety. Each state has a different PE exam but many have reciprocity between them.

Passing the exam allows the engineer to become a PE and have the ability to sign and stamp engineering drawings, allowing them to go from design to construction. Holding a PE gives an engineer more opportunities, such as higher pay, job preference, and better job security. A PE on a business card or resume sets one apart from other candidates as being more prepared and better equipped. It also grants respect from others in the community. By holding a PE, you have gained the respect of those working under you, along with you, and above you as being qualified and competent to provide safe and high quality work.

Table of Contents

Chapter 1: Introduction	1
Chapter 2: Background	3
2.1 Wachusett Reservoir	3
2.2 Relevant Stakeholders	3
2.2.1 U.S. Environmental Protection Agency	4
2.2.2 Massachusetts Water Resources Authority	4
2.2.3 The Department of Conservation and Recreation	4
2.2.4 Massachusetts Department of Transportation	5
2.2.5 Worcester Polytechnic Institute	5
2.3 Stormwater Management	6
2.3.1 Interstate Stormwater Runoff	6
2.3.2 Stormwater Regulations	6
2.3.3 Best Management Practices	6
2.3.4 Quality Concerns	7
2.3.4.1 Specific Conductance	7
2.3.4.2 Metals	8
2.3.4.3 Total Suspended Solids	9
2.3.4.4 pH	9
Chapter 3: Methodology	10
3.1 Selection of Basin	11
3.1.1 Accessibility	11
3.1.2 Direct Inlet of Runoff	12
3.1.3 Size	12
3.1.4 Drainage Area	12
3.1.5 Proximity to Monitoring Station	12
3.2 Understanding the Basin	13
3.2.1 Sampling Plan	13
3.2.1.1 Location and Description	13
3.2.1.2 Samples	15
3.2.2 Storm Selection	15
3.2.2.1 Sampling Timeline	15
3.2.3 Field and Lab Procedures	16
3.2.3.1 Soil	17
3.2.3.2 Water from Stream	18
3.2.3.3 Construction of Weir	19
3.2.3.4 Runoff	20
3.2.3.5 Construction of Piezometers	21
3.2.3.6 Groundwater	22
3.2.4 Desktop Analysis	23
3.2.4.1 Flow Rate Cipolletti Weir	23

3.2.4.2 HydroCAD©	23
Chapter 4: Results	26
4.1 Project Basin	26
4.1.1 Selection of Basin	26
4.1.2 Basin Drainage Area	27
4.1.3 Layout of Basin	28
4.2 Hydrograph.....	30
4.2.1 Weir Design & Construction.....	30
4.2.2 CN Values and Tc.....	30
4.2.3 Storm Data	31
4.2.4 Mathematically Calculated Flow Rates.....	33
4.2.5 HydroCAD© Output	33
4.3 Field Observations.....	35
4.4 Stormwater and Basin Characteristics.....	35
4.4.1 Runoff.....	35
4.4.1.1 Sodium in Runoff	35
4.4.1.2 Magnesium in Runoff	38
4.4.1.3 Specific Conductance and Na in Runoff.....	39
4.4.1.4 TSS in Runoff.....	40
4.4.1.5 TSS and Specific Conductance in Runoff.....	41
4.4.2 Soil.....	43
4.4.3 Groundwater	45
4.4.3.1 Sodium in Groundwater	46
4.4.3.2 Magnesium in Groundwater.....	47
4.4.3.3 TSS in Groundwater	48
4.4.4 Surface Water	49
4.4.4.1 Sodium in Surface Water	50
4.4.4.2 Specific Conductance in Surface Water.....	51
Chapter 5: Recommendations / Design	53
5.1 Optimal Basin Design.....	53
5.1.1 Size	56
5.1.2 Sediment Forebay	58
5.1.2.1 Potential Spill on Highway	59
5.1.3 Check Dam	59
5.1.4 Liner	59
5.1.5 Soil.....	60
5.1.6 Plants.....	61
5.1.7 Outlet	62
5.1.8 Groundwater Testing Well.....	62
5.1.9 Trash Rack	63
5.1.10 Removal of Fences	64
5.2 Stormwater Management Standards.....	64

5.2.1 Standard 1: Erosion	64
5.2.2 Standard 2: Peak Discharge	64
5.2.3 Standard 3: Recharge Volume	64
5.2.4 Standard 4: Water Quality Volume	65
5.2.5 Standard 5: LUHPPL	66
5.2.6 Standard 6: Critical Area Discharges	66
5.2.7 Standard 7: Redevelopment	67
5.2.8 Standard 8: Construction	67
5.2.9 Standard 9: O&M Plan	67
5.2.10 Standard 10: Illicit Discharges	68
5.3 Alternative Recommendations for Current Project Basin	68
5.3.1 Road Salt Alternatives	68
Chapter 6: Conclusion	69
Chapter 7: References	71
Chapter 10: Appendices	74
Appendix A: Project Proposal	74
Appendix B: Layout	93
Appendix C: Thermometer Procedure	96
Appendix D: Lab Procedures	97
Appendix D: 1 Specific Conductance	97
Appendix D: 2 Total Suspended Solids	98
Appendix D: 3 Test for Elements: Soil	100
Appendix D: 4 Test for Elements and Anions: Runoff and Groundwater	101
Appendix E: Drainage Area	102
Appendix F: Flow Rates	104
Appendix F: 1 Cipolletti Weir Hand Calculations	104
Appendix F: 2 HydroCAD©	104
Appendix G: Field Notes	106
Appendix G: 1 Field Visit 9-26-2016	106
Appendix G: 2 Field Visit 10-27-2016	109
Appendix G: 3 Field Visit 11-2-2016	111
Appendix G: 4 Field Visit 11-14-2016	118
Appendix G: 5 Field Visit 11-15-2016	121
Appendix G: 6 Field Visit 11-16-2016	125
Appendix G: 7 Field Visits 11-29-2016	128
Appendix G: 8 Field Visit 12-2-2016	131
Appendix H: Data Sheets	135
Appendix H: 1 Field Data Sheet: Surface Water	135
Appendix H: 2 Field Data Sheet: Runoff	136
Appendix H: 3 Field Data Sheet: Groundwater	137

Appendix H: 4 Field Data Sheet: Soil.....	138
Appendix H: 5 Lab Data: Digested Metals.....	138
Appendix H: 6 Lab Data: Digested Minerals	139
Appendix H: 7 Lab Data: Dissolved Metals	140
Appendix H: 8 Lab Data: Dissolved Minerals	141
Appendix I: Graphs.....	142
Appendix I: 1 Soil.....	142
Appendix I: 2 Runoff	143
Appendix J: USGS Storm Data	152
Appendix J: 1 USGS 11/15/2016 Data.....	152
Appendix J: 2 USGS 11/29/2017 Data.....	154

Table of Figures

FIGURE 1: WACHUSETT RESERVOIR (GOOGLE, 2016)	3
FIGURE 2: WACHUSETT WATERSHED (USGS, 2016).....	5
FIGURE 3: METHODOLOGY FLOW CHART	10
FIGURE 4: ACCESSIBLE BASIN	11
FIGURE 5: INACCESSIBLE BASIN.....	11
FIGURE 6: BASIN 16:07 SAMPLING LOCATIONS.....	13
FIGURE 7: UPSTREAM & DOWNSTREAM LOCATION (OLIVER, 2017).....	14
FIGURE 8: CORING DEVICE IN SOIL.....	17
FIGURE 9: SUBMERGED SAMPLE BOTTLE.....	18
FIGURE 10: WEIR OUTLINE	19
FIGURE 11: SETUP OF WEIR WITH SANDBAGS.....	19
FIGURE 12: STORM RUNOFF POOL	20
FIGURE 13: CUTTING PIEZOMETER SLITS	21
FIGURE 14: PIEZOMETER IN SOIL.....	21
FIGURE 15: COLLECTION OF GROUNDWATER SAMPLES WITH GEOPUMP	22
FIGURE 16: PROJECT BASIN ROUTING DIAGRAM	24
FIGURE 17: PROJECT BASIN HYDROCAD© AREAS AND CN.....	24
FIGURE 18: INPUTTING STORMS.....	25
FIGURE 19: PROJECT BASIN (GOOGLE, 2017)	26
FIGURE 20: BASIN SELECTION	27
FIGURE 21: PROJECT BASIN DRAINAGE AREA.....	27
FIGURE 22: OVERVIEW OF BASIN	28
FIGURE 23: ORIGINALLY CONSTRUCTED SEDIMENT BASIN	29
FIGURE 24: ORIGINAL SEDIMENT BASIN DIMENSION CHART FROM PLANS	29
FIGURE 25: PROJECT BASIN Tc FLOW LENGTH	31
FIGURE 26: CUMULATIVE PRECIPITATION OF STORM 1 AND STORM 2	32
FIGURE 27: FLOWRATE AND RAINFALL FOR STORM 1 AND STORM 2 DURING SAMPLING PERIOD	33
FIGURE 28: STORM 1 HYDROCAD© HYDROLOGY	34
FIGURE 29: STORM 2 HYDROCAD© HYDROLOGY	34
FIGURE 30: RUNOFF DISSOLVED METALS WITH TOTAL PRECIPITATION FROM STORM 1	36
FIGURE 31: RUNOFF DISSOLVED METALS WITH TOTAL PRECIPITATION FROM STORM 2	37
FIGURE 32: COMPARISON OF NA FOR CUMULATIVE PRECIPITATION OF STORM 1 AND STORM 2	37
FIGURE 33: RUNOFF DISSOLVED METALS W/O NA WITH SPECIFIC CONDUCTANCE FROM STORM 1.....	38
FIGURE 34: COMPARISON OF MG FOR CUMULATIVE PRECIPITATION OF STORM 1 AND STORM 2	39

FIGURE 35: COMPARISON OF NA AND SPECIFIC CONDUCTANCE OF STORM 1 AND STORM 2	40
FIGURE 36: RUNOFF TESTED FOR TSS WITH CUMULATIVE RAINFALL FOR STORM 1 AND STORM 2	41
FIGURE 37: RUNOFF TESTED FOR SPECIFIC CONDUCTANCE VS. TSS STORM 1	42
FIGURE 38: RUNOFF TESTED FOR SPECIFIC CONDUCTANCE VS. TSS STORM 2	42
FIGURE 39: SOIL SAMPLE MAP	43
FIGURE 40: SOILS TESTED FOR TOTAL METALS.....	44
FIGURE 41: GROUNDWATER SAMPLE MAP	45
FIGURE 42: GROUNDWATER TESTED FOR DISSOLVED METALS STORM 1.....	46
FIGURE 43: GROUNDWATER TESTED FOR DISSOLVED METALS STORM 2.....	46
FIGURE 44: GROUNDWATER TESTED FOR DISSOLVED METALS STORM 1 W/O NA	47
FIGURE 45: GROUNDWATER TESTED FOR DISSOLVED METALS STORM 2 W/O NA	48
FIGURE 46: GROUNDWATER TESTED FOR TSS	49
FIGURE 47: STORM 1 GROUNDWATER SAMPLES	49
FIGURE 48: SURFACE WATER TESTED FOR DISSOLVED METALS UPSTREAM & DOWNSTREAM STORM 2	50
FIGURE 49: SURFACE WATER TESTED FOR DISSOLVED METALS UPSTREAM & DOWNSTREAM STORM 2 W/O NA.....	50
FIGURE 50: SURFACE WATER DOWNSTREAM VS. UPSTREAM TESTED FOR DISSOLVED METALS DURING STORM 2.....	51
FIGURE 51: OPTIMAL BASIN LAYOUT.....	54
FIGURE 52: OPTIMAL BASIN SECTION.....	56
FIGURE 53: OPTIMAL BASIN EVENTS.....	58
FIGURE 54: GROUNDWATER TESTING WELL (SEWAGE DISPOSAL SYSTEM, 2015)	63
FIGURE 55: TRASH COLLECTION RACK DESIGN OPTION (MISC. METALS, 2012).....	63
FIGURE 56: IMPERVIOUS AREA.....	65
FIGURE 57: ZONE A AREA (OLIVER, 2016)	67
FIGURE 58: SIDE VIEW OF THE SEDIMENTATION POOL'S DITCH	93
FIGURE 59: TOP AND SIDE VIEW OF INLET WEIR	93
FIGURE 60: TYPE 1 OF BARRIER	94
FIGURE 61: TYPE 2 OF BARRIER	94
FIGURE 62: SIDE VIEW OF OUTLET WEIR.....	94
FIGURE 63: TOP VIEW AND SIDE VIEW OF THE BASIN.....	95
FIGURE 64: MEASUREMENT OF TEMPERATURE.....	96
FIGURE 65: SPECIFIC CONDUCTANCE PROBE.....	97
FIGURE 66: KNF NEUBERGER VACUUM PUMP	99
FIGURE 67: DRIED FILTER WITH SOLIDS PRESENT.....	99
FIGURE 68: PLACEMENT OF SOIL SAMPLE ON PAN.....	100
FIGURE 69: SOIL DRIED IN OVEN.....	100
FIGURE 70: PROJECT BASIN 16:07 1S HYDROCAD© OUTPUT.....	104
FIGURE 71: BASIN 16:07 1P SUMMARY HYDROCAD© OUTPUT.....	105
FIGURE 72: OPTIMAL BASIN 1P SUMMARY.....	105
FIGURE 73: SOILS TESTED FOR DIGESTED METALS	142
FIGURE 74: SOILS TESTED FOR DIGESTED METALS W/O AL AND MG	142
FIGURE 75: RUNOFF TESTED FOR PH VS. SPECIFIC CONDUCTANCE FOR STORM 2.....	143
FIGURE 76: RUNOFF TESTED FOR DISSOLVED METALS WITH SPECIFIC CONDUCTANCE FOR STORM 1	143
FIGURE 77: RUNOFF TESTED FOR DISSOLVED METALS WITH PH FOR STORM 2	144
FIGURE 78: RUNOFF DISSOLVE METALS WITH TOTAL PRECIPITATION FROM STORM 1	144
FIGURE 79: RUNOFF METALS W/OUT NA WITH TOTAL PRECIPITATION FROM STORM 1	145
FIGURE 80: RUNOFF DISSOLVED METALS WITH CUMULATIVE PRECIPITATION FROM STORM 2	145

FIGURE 81: RUNOFF DISSOLVED METALS W/OUT NA WITH CUMULATIVE PRECIPITATION FROM STORM 2	146
FIGURE 82: GROUNDWATER TESTED FOR DISSOLVED METALS STORM 1	146
FIGURE 83: GROUNDWATER TESTED FOR DISSOLVED METALS STORM 1 WITHOUT NA	147
FIGURE 84: GROUNDWATER TESTED FOR DIGESTED METALS STORM 1	147
FIGURE 85: GROUNDWATER TESTED FOR DIGESTED METALS STORM 1 WITHOUT NA	148
FIGURE 86: GROUNDWATER TESTED FOR DISSOLVED METALS STORM 2	148
FIGURE 87: GROUNDWATER TESTED FOR DISSOLVED METALS STORM 2 WITHOUT NA	149
FIGURE 88: STREAM WATER TESTED FOR TSS	149
FIGURE 89: SURFACE WATER DOWNSTREAM VS. UPSTREAM TESTED FOR DISSOLVED METALS DURING DRY WEATHER	150
FIGURE 90: SURFACE WATER DOWNSTREAM VS. UPSTREAM DISSOLVED METALS W/OUT NA	150
FIGURE 91: SURFACE WATER DOWNSTREAM VS. UPSTREAM TESTED FOR DISSOLVED METALS STORM 2	151
FIGURE 92: SURFACE WATER DOWNSTREAM VS UPSTREAM TESTED FOR DISSOLVED METALS STORM 2 W/OUT NA	151

Table of Tables

TABLE 1: SAMPLE ITINERARY	16
TABLE 2: SOIL COLLECTION SUPPLIES AND PROCEDURE	17
TABLE 3: WATER COLLECTION SUPPLIES AND PROCEDURE	18
TABLE 4: WEIR CONSTRUCTION SUPPLIES AND PROCEDURE	19
TABLE 5: RUNOFF COLLECTION SUPPLIES AND PROCEDURE	20
TABLE 6: PIEZOMETERS CONSTRUCTION SUPPLIES AND PROCEDURE	21
TABLE 7: GROUNDWATER COLLECTION SUPPLIES AND PROCEDURE	22
TABLE 8: NODE 1P PARAMETERS	25
TABLE 9: ACRES AND CN VALUES	30
TABLE 10: FLOW LENGTHS AND WATERCOURSE SLOPE	31
TABLE 11: SOIL SAMPLE LOCATION AND TYPE	44
TABLE 12: SIMILARITIES AND DIFFERENCES BETWEEN PRESENT AND OPTIMAL BASIN	55
TABLE 13: 1982 RAWLS RATES	57
TABLE 14: PLANT MATRIX	61
TABLE 15: RECHARGE TARGET DEPTH BY HYDROLOGIC SOIL GROUP (HANDBOOK, 2008)	65
TABLE 16: TEMPERATURE MEASUREMENT SUPPLIES AND PROCEDURE	96
TABLE 17: GROUNDWATER COLLECTION SUPPLIES AND PROCEDURE	97
TABLE 18: TOTAL SUSPENDED SOLIDS SUPPLIES AND PROCEDURE	98
TABLE 19: SOIL SAMPLE SUPPLIES AND PROCEDURE	100
TABLE 20: DISSOLVED METAL SUPPLIES AND PROCEDURE	101
TABLE 21: DIGESTED METAL SUPPLIES AND PROCEDURE	101
TABLE 22: FLOW RATES FOR STORM SAMPLES	104

Table of Equations

EQUATION 1	23
EQUATION 2	23
EQUATION 3	23
EQUATION 4	57
EQUATION 5	57
EQUATION 6	65
EQUATION 7	66

Chapter 1: Introduction

“Stormwater runoff is generated from rain and snowmelt events that flow over land or impervious surfaces, such as paved streets, parking lots, and building rooftops, and does not soak into the ground” according to the US Environmental Protection Agency (EPA). This can be problematic because as the water moves over land or impervious surfaces it picks up various sources of contaminants and carries them to rivers, lakes, reservoirs, etc., threatening their water quality (EPA, 2016b). Specifically, road runoff can contain heavy metals, oils, debris and other toxic substances that are generated from construction, road maintenance and traffic (Nonpoint Source: Roads Highways and Bridges, 2015). This has a direct impact on water quality, especially for drinking water sources such as a reservoir. The need to maintain water quality provides the framework for setting up points of treatment for stormwater.

In Massachusetts, reservoirs are a crucial component in needed to provide clean drinking water. Maintaining a high quality of water in surface water bodies minimizes the amount of treatment required prior to distribution to communities. The Department of Conservation and Recreation (DCR) monitors the Wachusett Reservoir through sampling at water quality stations, which supplies water to the Greater Boston area through the Massachusetts Water Resources Authority (MWRA).

A portion of this watershed and a number of tributary streams associated with the Wachusett Reservoir are in close proximity to Interstate-190 (I-190). Since highways are a main source of runoff and accumulation of pollutants, Stormwater Best Management Practices (BMPs) have been established in this region to control and treat this runoff before it enters the reservoir to protect the water quality. The type of BMP used along I-190 is a stormwater treatment basin which temporarily stores water during storms. This type is typically found near roads with large amounts of traffic (Pennsylvania Stormwater Best Management Practices Manual, 2013).

The DCR and our Worcester Polytechnic Institute (WPI) Major Qualifying Project (MQP) Team agreed to work together to gain a better understanding of the function of these BMPs in protecting water quality. The goal of this project was to evaluate the impact of the basins along I-190 in controlling runoff and develop appropriate recommendations to improve its effectiveness. These basins were crucial in controlling the impact of the runoff, but the effects of these basins were not monitored. Comprehension of these effects was completed through sampling, testing and data analysis that focused on specific conductance, heavy metals and Total Suspended Solids (TSS). To accomplish our goal, we developed the following objectives:

Objective 1: Develop an understanding of the impacts of highway runoff to the watershed and the use of a stormwater treatment basin as a management technique.

- Review relevant literature regarding highway runoff and stormwater management
- From possible basins, select project basin to focus on for testing and analysis
- Perform collection of soil samples and groundwater samples in the project basin
- Perform collection of water samples in the project basin and locations in the Stillwater River
- Analyze samples in the laboratory

Objective 2: Develop findings and identify deficiencies of the project basin.

- Compare analyzed data to stormwater regulations and standards
- Determine which contaminants negatively affect the water quality

Objective 3: Deduce recommendations for the DCR that will improve the project basin and maximize its potential for protecting water quality.

- Develop innovative design components and improvements for the project basin
 - Complete a design for an optimal basin that improves water quality and supports capacity storm events
 - Provide suggestions and design alternatives to improve current project basin based on real world constraints such as a lack of resources and finances

Chapter 2: Background

A literature review of the main topics in this project is necessary to provide a basic understanding of what the project entails. This was done through research of the Wachusett Reservoir, the parties associated with the reservoir, stormwater runoff, regulations and best management practices. This process of reviewing past literature helps strengthen our team's understanding of the project and allows us to move forward with the development of the methodology.

2.1 Wachusett Reservoir

The Wachusett Dam was constructed in order to create the Wachusett Reservoir, resulting in the restriction of the flow of the Nashua River partially in the flooding areas of Boylston, West Boylston, Clinton and Sterling (MWRA, 2015). Since construction was completed in 1905 the reservoir has reached capacity at 4,135-acres of surface area (Energy and Environmental Affairs, 2016). The MWRA incorporated the Wachusett Reservoir into its water system due to the continual growth of the Boston area. In 2015, with the additional input flowing from the Quabbin Reservoir, the average volume of the reservoir was 58977-mg (MWRA, 2016a). Fifty-one communities in Massachusetts receive their water from a combination of the Wachusett and Quabbin Reservoirs through purchasing contracts with the MWRA (MWRA, 2016). The Wachusett Reservoir can be seen in Figure 1.

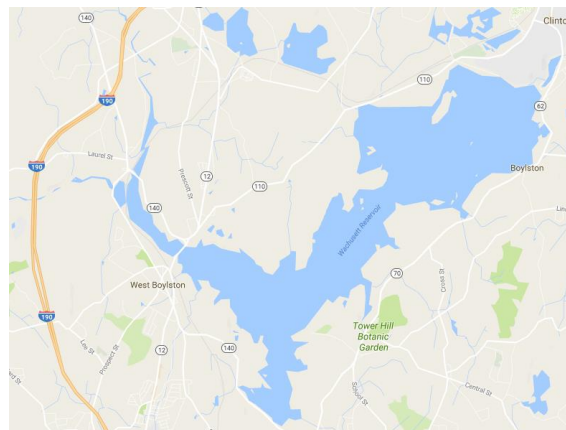

FIGURE 1: WACHUSETT RESERVOIR (GOOGLE, 2016)

2.2 Relevant Stakeholders

Various stakeholders concerned with the Wachusett Watershed were utilized in this project as a source of research and information particularly in regards to stormwater management and water quality. The Wachusett Reservoir is co-managed by the MWRA and the DCR. The parties must work together to follow the requirements, regulations and guidance provided by the EPA. Part of ensuring that they meet the EPA standards is working with the Massachusetts Department of Transportation (MassDOT) to ensure BMPs along roadways are being maintained to a regulated

standard. Our team took into account all parties during the project; working closely with the DCR while taking input from the MassDOT.

2.2.1 U.S. Environmental Protection Agency

The EPA's Office of Water (OW) is tasked with ensuring that drinking water is safe for consumption while restoring and maintaining oceans and watersheds to protect human life and ecosystems. They implemented both the Clean Water Act (CWA) and Safe Drinking Water Act to ensure the reduction of runoff and improvement of water quality. In Massachusetts, the EPA is responsible for implementation and oversight of the National Pollutant Discharge Elimination System permit program (Tetra Tech, 2010). The various stormwater management programs set up by the EPA are the guidelines our sponsor and the impacted communities need to comply with.

2.2.2 Massachusetts Water Resources Authority

The MWRA is responsible for the delivery and distribution of the reservoir water. To ensure they are providing reliable and quality water, they implemented the Integrated Water Supply/ Quality Program, in addition to complying with the EPA's Safe Drinking Water Act (MWRA, 2015). The MWRA has to treat water if needed before it is distributed, therefore any data our team can provide pertaining to the runoff that goes from the stormwater treatment basins to the reservoir could be beneficial.

2.2.3 The Department of Conservation and Recreation

The DCR's responsibility for the Wachusett Reservoir is to keep the water supply clean and protected against various sources of contamination. The DCR oversees the 21,028 acres of land that contains the Wachusett Reservoir and the watershed which surrounds the reservoir as seen in Figure 2 (DCR, 2004). The DCR's oversight of the watershed area is important because the reservoir is naturally replenished from precipitation that enters the watershed and makes its way to the reservoir. Although land surrounding the reservoir is a mix of forest and wetlands, some land uses, such as roads, increase the potential of contamination to the reservoir (MWRA, 2016). Stormwater treatment basins are in place along the highways and some local roads, but the DCR would like to have a better understanding of the overall effectiveness and performance of them. Through a better understanding of what is flowing into the basins and how the basins are capturing or releasing contaminants, the DCR will be more aware of how they can contribute to effectively protecting the reservoir.

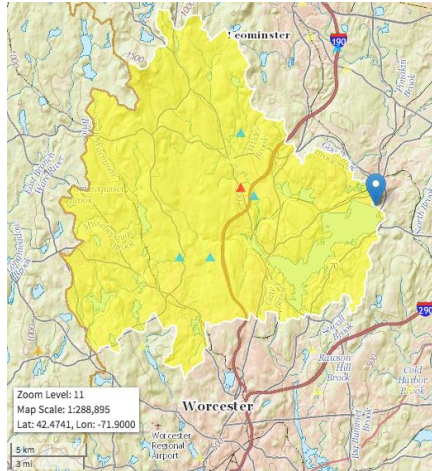

FIGURE 2: WACHUSETT WATERSHED (USGS, 2016)

2.2.4 Massachusetts Department of Transportation

During this project the MassDOT is listed as a contributing party because they have provided us with access into the basins and gave the DCR permission to provide maintenance to the project basin. MassDOT was a point of contact for our team, providing additional resources and advice on current stormwater practices. Additionally, the MassDOT has a main role in MA in protecting water quality and must consider various regulations and factors while providing a safe and reliable transportation system. This is done through the process of abiding by their Stormwater Management Plan revised in 2009 that was granted with the approval of their Notice of Intent application for the EPA's National Pollutant Discharge Elimination System General Permit for Stormwater Discharges from Small Municipal Separate Storm Sewer Systems (National Pollutant Discharge Elimination System, 2016). Since I-190 runs north to south on the west side of the reservoir as shown in Figure 2, it may cause risks to the quality of the water in the reservoir over a long period of time. Due to this potential risk, during the construction of I-190, sediment basins were put into place to capture water runoff from the roads during storms. According to Vincent Vignaly, from the DCR, some of the stormwater treatment basins in place today along I-190 were converted from the construction-phase sediment basins.

2.2.5 Worcester Polytechnic Institute

Our WPI team wants to effectively work with the DCR to create a deliverable that can be utilized and ideally implemented to improve the water quality of the Wachusett Reservoir in regards to stormwater treatment basins. Our team needs to ensure that along with the data and recommendations provided, there is also a capstone design element. In addition, we want to learn new skills and gain knowledge in concern with runoff, groundwater, soil, contamination impacts, watershed characteristics, sampling collection, and testing.

2.3 Stormwater Management

As previously mentioned in Chapter 1 Introduction, stormwater runoff collects contaminants as it moves through an area transporting them to bodies of water. This is a risk to water quality therefore BMPs are used to help mitigate the effects of these contaminants to surface water.

2.3.1 Interstate Stormwater Runoff

Multiple studies have been conducted pertaining to stormwater runoff to discover what is coming off of highways, the quantity of these contaminants, and why these contaminants are present. A recent study was done by the MassDOT, in partner with US Department of Transportation and USGS, *Quality of Stormwater Discharge from Massachusetts Highways, 2005-07*. The study looked at twelve sites along multiple highways with different amounts of traffic for two years by using automatic samplers. The study investigated runoff volume, turbidity, pH, and recoverable metals. The results showed that runoff during a rainstorm and snowmelt have higher levels of pollutants. pH was discovered to fluctuate depending on the time of year and runoff quantity. The study also conclusively found that deicing materials and maintenance sand are the leading contributors to spikes of pollutants in levels during winter months. The levels of chloride, nitrogen, total-recoverable metals, phosphorus, iron, and manganese, rose over the two years due to fuels, lubricants, antifreeze, windshield fluids, deicing, maintenance sand, and other automotive components (Smith, 2002). These increased levels are not as common in runoff generated from less busy roadways.

2.3.2 Stormwater Regulations

The EPA has set standards in regards to the amount of pollutants that can be present in stormwater runoff through the CWA and National Pollutant Discharge Elimination System (NPDES). The NPDES sets up a permitting system through the EPA to regulate runoff with a focus on protecting drinking water sources. “Mass Highway Stormwater Handbook for Highways and Bridges” written in 2004 states Massachusetts specific guidelines for stormwater best management practices. These guidelines include controls for wetlands, untreated stormwater, and removal efficiencies.

2.3.3 Best Management Practices

BMPs are used to mitigate the entrance of sediment and contaminants into the surface water and groundwater from various sources such as stormwater. The BMP we focused on in this project is a stormwater treatment basin. This type of BMP collects water during storms, reducing the chance of flooding and traps contaminants in the basin. Initially at this site were sediment basins, built during construction, but they were converted into treatment basins which permanently remained. According to the *Massachusetts Erosion and Sediment Control Guidelines*, sediment basins are a “settling pond with a controlled stormwater release structure

used to store and collect sediment” and “usually consist of an earth dam, spillway to carry normal water flow, and an emergency spillway for storm flows.” Stormwater treatment basins contain one or more chambers that divide the basin to make the basin more effective (Franklin, Hampden, Hampshire Conservation Districts, 2013).

Other BMPs used by MassDOT as described in the MassDOT Stormwater Handbook are stated in this section. An Infiltration BMP is commonly used by MassDOT and essentially is a basin with filtration methods, such as a soil layer to groundwater filtering runoff and contaminants, and providing groundwater recharge. Vegetation, a sediment forebay, and a basin invert are crucial for success of this basin, providing up to 100% TSS removal. Biofiltration BMPs are shallow basins that filter stormwater through vegetation and soil media that has been engineered with some microbial processes. Through this up to 100% TSS removal can be achieved. One type of this BMP is Filtering Bioretention areas where infiltration cannot be used in areas of poor soil. The other type is Exfiltrating Bioretention areas where groundwater recharge and infiltration occurs. Another type of BMP is a Stormwater Wetlands. Constructed Stormwater Wetlands resemble wetlands where the basin site must have the ability to be naturally wet throughout the year. Sedimentation, sorption and microbial processes are used for treatment, with 60-80% TSS removal. A Subsurface Gravel Wetland is a subsurface structure that has a sediment forebay with at least one other subsurface component. The various elements of the basin provide aerobic and anaerobic treatment with up to 100% TSS removal. The last BMP to be discussed is a Wet Pond which is used in an area with significant pooling throughout the year and uses settling and storage mechanisms to treat stormwater. It provides 60-80% TSS removal. The characteristics of these various BMPs can be used for reference when designing the optimal basin.

2.3.4 Quality Concerns

In order to ensure the continued flow of high quality water into the reservoir, the DCR performs routine sampling, analysis, and patrolling of the surrounding tributaries. From the water quality data of the surrounding tributaries and the reservoir collected in 2015, the DCR prepared a Water Quality Report. Based on the available data, the areas of focus of this report were bacteria, specific conductance, turbidity, pH and temperature.

2.3.4.1 Specific Conductance

Specific conductance is the measurement of water’s ability to support an electric current. This can then be used to determine what ions are present in water. Currently there are nineteen tributaries in the Wachusett Watershed region that are tested on a weekly or biweekly basis for specific conductance (2015 Water Quality Report, 2016). Potential factors that can increase specific conductance are dissolved solids and runoff from vehicles and salts such as NaCl (Murphy, 2007).

The Quinapoxet and Stillwater Rivers are the two main tributaries to Wachusett Reservoir and are estimated to account for approximately 75 percent of annual inflow from the reservoir watershed. Measurements of conductivity in these rivers generally range between 60 and 240 uS/cm with an average value between 125 and 150 uS/cm (2015 Water Quality Report, 2016).

These average values mentioned previously can then be used as a comparison to the values of specific conductance found in the runoff, soil and groundwater of the project basin. If the values found in the basin are higher it shows that the runoff off of I-190 has poorer water quality than the tributaries, “elevated conductivity levels indicate contamination from stormwater” (2015 Water Quality Report, 2016). Sampling of the progression of specific conductance throughout the basin reveals how the basin is trapping the ions. It is important to address specific conductance at its source or prior to entrance into the reservoir because it minimizes the need for additional treatment prior to distribution. “During periods of isothermy and mixing (November through March), conductivity values throughout the main Wachusett basin typically range from 75 to 145 uS/cm” (2015 Water Quality Report, 2016). Additionally, numerous criteria need to be met according to the Federal Surface Treatment Rule or implementing filtration will be required (2015 Water Quality Report, 2016).

2.3.4.2 Metals

Heavy metals are a main area of concern with regards to stormwater runoff potentially impacting water supply and aquatic life. Heavy metals are present on highways due to the use of automobiles and industry (Environmental Assessment, 2016).

Lead, zinc and copper are common metals present from automobiles pertaining to certain aspects of the vehicle. Lead is present due to “leaded gasoline, tire wear, lubricating oil and grease, bearing wear, and atmospheric fallout” (Smith, 2010). Zinc is present from “tire wear, motor oil, and grease” (Smith, 2010). Copper is present in the runoff due to “metal plating, bearing wear, engine parts, brake lining wear, and fungicides and insecticides use” (Smith, 2010).

Road maintenance materials such as road salt (sodium chloride), sand (phosphorus, iron, and manganese), and liquid magnesium chloride all contribute to higher levels of metals on roadways during winter months. As a result, states that have to perform road maintenance due to snow should consider the impact that these additional pollutants have on the environment (Smith, 2010).

Metals can accumulate in soil depending on the solubility of the metals and the chemistry of the soil. This interaction between the soil and the metals can cause the trapping of certain metals in the soil in the stormwater treatment basin. The exchange process can be seen when dissolved

metals exchange with metals found in the soil. This process would cause the metals to remain in the basin, maintaining a high quality outflow from the basin (Evanko, 1997).

2.3.4.3 Total Suspended Solids

According to the “2015 Water Quality Report for the Wachusett Reservoir Watershed” “total suspended solids are those particles suspended in a water sample retained by a filter of 2µm pore size.” These particles can be naturally present or result from human activity. In general, “total suspended solids in Wachusett tributaries ranged from <5.0 mg/L to 22 mg/L, but only five of 110 samples contained more than the detection limit” in the 2015 report, revealing TSS to not typically be of concern. During storms though “measurements in excess of 100 mg/L are not uncommon,” therefore samples for measuring TSS were collected in the project basin and Stillwater River during dry and wet weather as comparison. It is common for TSS to accumulate in stormwater due to runoff containing pavement wear, road salt, debris, and vehicle exhaust emissions (Smith, 2010).

2.3.4.4 pH

The Wachusett Reservoir is routinely tested for pH, the activity of hydrogen ions. "Generally, pH values in Wachusett Reservoir are unremarkable, ranging from around neutral (pH=7) to slightly acidic (pH=6)" (2015 Water Quality Report, 2016). Due to these consistently minor fluctuations, pH is not typically a point of concern but we measured it in runoff, groundwater and river samples as a point of reference.

Chapter 3: Methodology

The goal of this project was to evaluate the impact of the stormwater treatment basins along I-190 in controlling runoff and develop appropriate recommendations to improve its effectiveness. To accomplish this the following tasks were performed. First, the project basin was selected from a list of 12 basins provided by the DCR. Selection criteria included accessibility, direct inlet of runoff, size, drainage area, and proximity to monitoring station. Then, a plan was developed and executed to determine the existing conditions of the basin through selecting storms, sampling, and desktop analysis. From the collected and analyzed data, desktop modeling was used to design an optimal BMP and adapt it to real life constraints. Figure 3 visualizes the tasks performed.

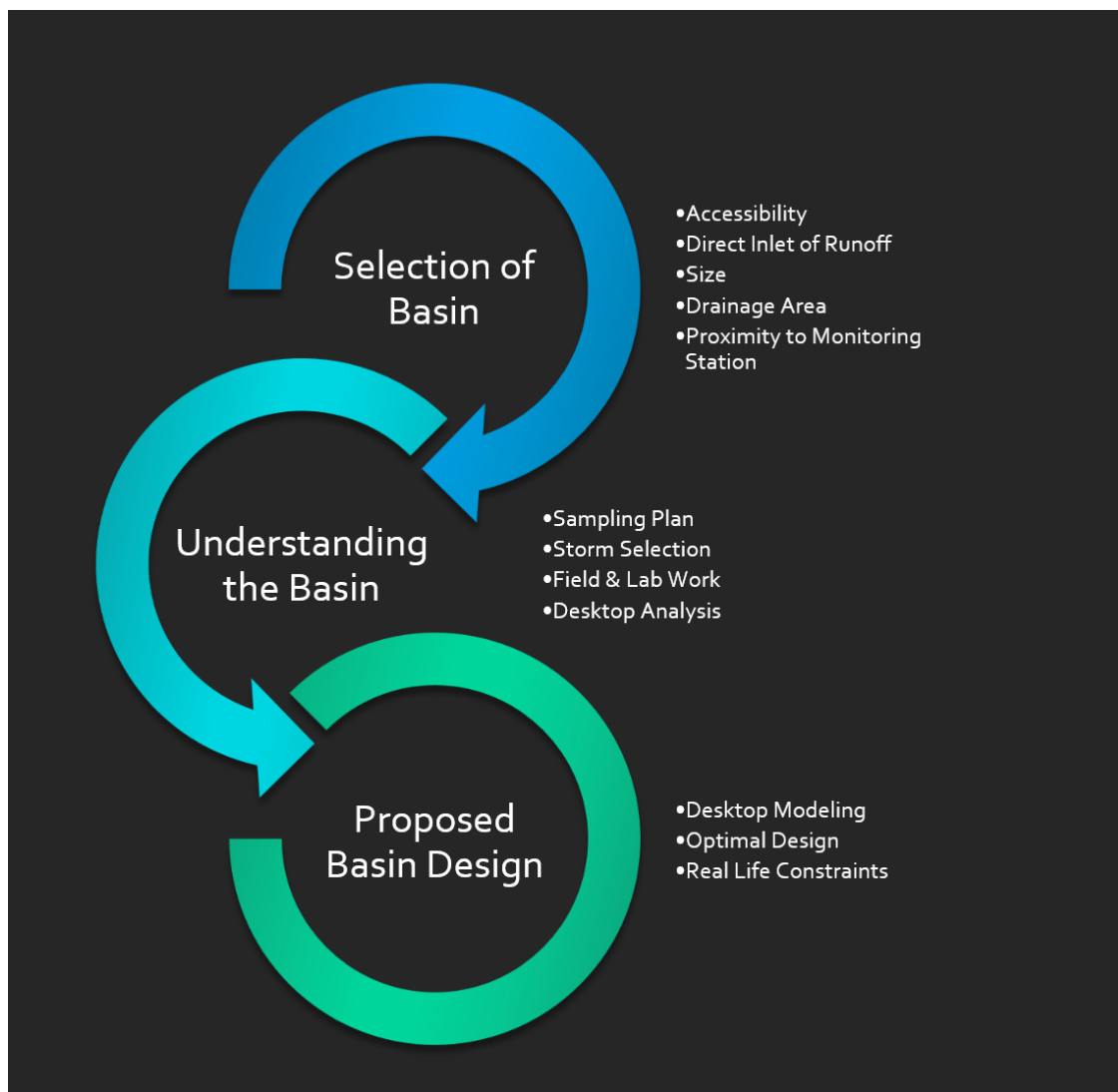

FIGURE 3: METHODOLOGY FLOW CHART

3.1 Selection of Basin

The project basin was selected through evaluation of various characteristics including accessibility, direct inlet of runoff, size, drainage area, and the location relative to monitoring stations. To evaluate these characteristics various basins were visited in the watershed region per suggestion of the DCR from their expertise and knowledge of the area. The site visits were documented, in Appendix G: Field Notes, and observations were made based upon general understanding of how basins work and what they are supposed to accomplish. We also reviewed the construction plans for the basins and used Arc Geographic Information System (ArcGIS).

3.1.1 Accessibility

The first criterion was to have a basin with feasible entry to allow for the completion of sampling. Daniel Crocker and other members of the DCR visited all potential basin sites at the commencement of the project to determine their accessibility. Later, our team visited the basins that were not clearly ruled out as inaccessible along with members of the DCR to evaluate their conditions. Many basins had not been maintained in several years, therefore, the locks were stuck or the basins were too overgrown to drive or walk through. Figure 4 demonstrates a basin with adequate access, while Figure 5 demonstrates an inaccessible basin. Basins with inadequate access were eliminated from consideration and the remaining basins moved on to be evaluated according to the next characteristic.



FIGURE 4: ACCESSIBLE BASIN



FIGURE 5: INACCESSIBLE BASIN

3.1.2 Direct Inlet of Runoff

Direct inlet of runoff was the next characteristic used to evaluate the basins. It was important for the basin to allow for runoff samples to be taken directly from I-190. Therefore, it was necessary to have a basin that was in close approximation to the highway. Our team evaluated the source of runoff by reviewing the construction plans and using Google maps to locate catch basins. Catch basins are placed on the sides of roads as a stormwater management practice to transport water off of the roadway. The findings were all confirmed during field visits. The basins that did not have direct pipe inlets for runoff from I-190 were taken off the list of potential basins and the remaining basins were further evaluated.

3.1.3 Size

The third characteristic of the basin that was reviewed was the size. The size of the basin was considered because our team wanted to be able to access the entire basin during the observation and sampling process. A large basin would require more soil and groundwater samples to be taken than able to be tested in the lab. Additionally, samples from a larger basin would have a higher likelihood of negligible detection levels since the contaminants in the basin would be more dispersed. Due to this the larger basins were eliminated from the list.

3.1.4 Drainage Area

Once it was determined that the basins on the list were of adequate size, the size of their drainage area also needed to be evaluated. A larger drainage area would maximize the chance of obtaining useful results from the samples taken due to the fact that the basin would have a larger volume of input. To determine the drainage areas of the basins the 2ft contours layer was used on ArcGIS in parallel with the basin construction plans drainage details. On both ArcGIS and the construction plans, the catch basins were used to correlate the two in order to determine the drainage area.

3.1.5 Proximity to Monitoring Station

Finally, our team decided on a basin that had the option of testing nearby water, such as a stream, pond or river. This was done to compare the samples from the project basin, which were directly from highway stormwater runoff, to a water source upstream and downstream from the project basin.

3.2 Understanding the Basin

3.2.1 Sampling Plan

A detailed sampling plan was created that included when, what, and how samples would be collected and analyzed. The purpose of collecting samples was to determine the efficiency of the basin. We measured specific conductance, pH, metal content, and TSS. Samples were taken at multiple locations in the basin to provide a well-rounded understanding of how the contaminants entered and moved through the basin. Runoff water samples were taken during storms to determine what entered the basin. Soil samples were collected to determine what contaminants were trapped by the soils. Groundwater samples were used to determine the metals that infiltrated the soil and verify if the substances left or remained in the basin area. Surface water samples were taken to determine how levels upstream and downstream of the basin differed from the runoff from I-190. All of the samples were tested in WPI's Kaven Hall Environmental Laboratory.

3.2.1.1 Location and Description

Selecting locations for sampling was crucial. Basin 16:07 was selected as the example basin to show the sampling plan which was later modified for the chosen basin. In Figure 6 the blue triangles represent runoff water samples, the red triangles represent soil samples, and the green triangles represent groundwater samples.

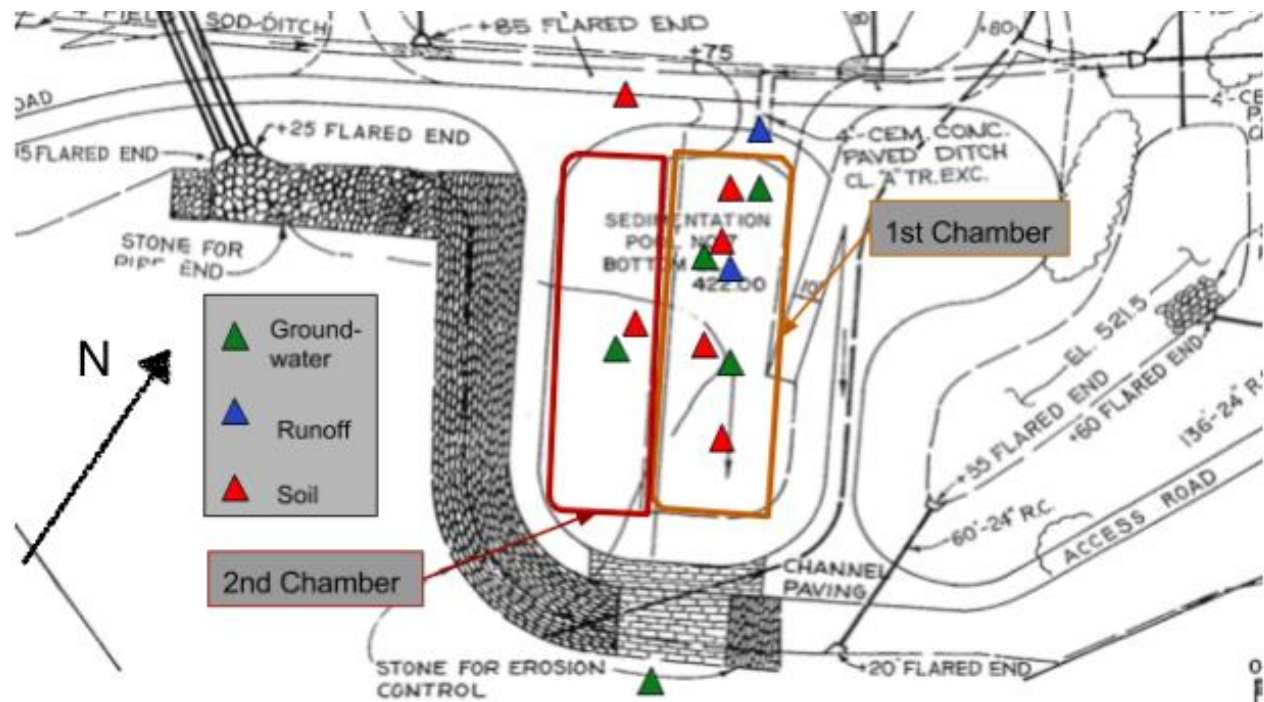

FIGURE 6: BASIN 16:07 SAMPLING LOCATIONS

Runoff samples were collected at the inlet of the basin at the cement inflow weir where multiple runoff points collect. The second location for runoff water samples was in the basin itself. Initially there was concern that this might be slightly more challenging since we noticed during our preliminary site visits that most of the basins were dry, but samples were able to be taken during and after storms. This provided a more well-rounded view of the basin and how the contaminants moved through it.

Soil samples were collected at the end of the inflow weir where a majority of sediments accumulated. Samples were also collected at two other locations in the first chamber, to allow our team to understand the types of sediments that were present in the basin. The team took a soil sample in Chamber 2 of the basin to better understand the flow of metals from Chamber 1 to the Chamber 2. Changes in the soil type and amount of topsoil from Chamber 1 to Chamber 2 provided our team information about soil flow. A control sample was taken near the basin at a location of the same soil type but was not theoretically contaminated by storm runoff from I-190.

Groundwater samples were taken near the proximity of the inflow weir and at two additional locations in Chamber 1. A groundwater sample was also collected in the second chamber of the basin and a sample was taken outside of the basin near a potential outflow to understand the contaminant movement.

In addition to the samples mentioned above, samples were also taken at two locations separate from the project basin, one upstream and one downstream of I-190 as shown in Figure 7.

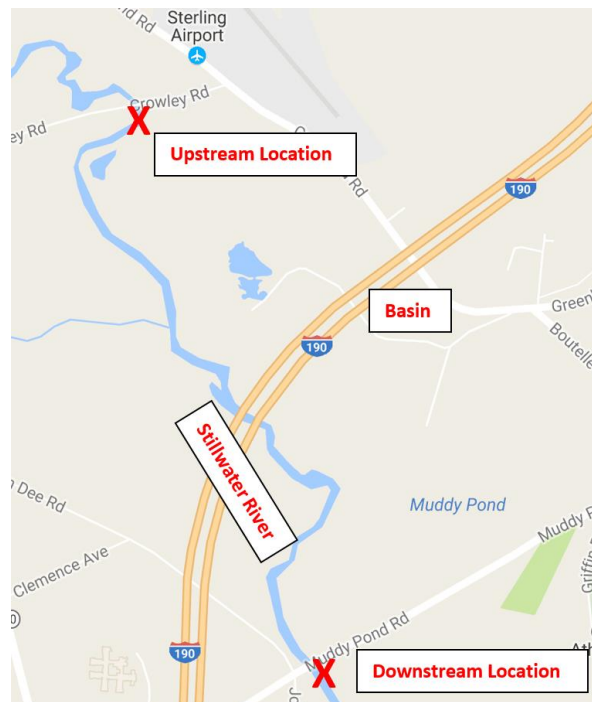

FIGURE 7: UPSTREAM & DOWNSTREAM LOCATION (OLIVER, 2017)

Although there were many contributing factors that flow into the Stillwater River, the river that flows perpendicular to I-190, sampling data provided us with a broader view of water quality in this region. The upstream sample was taken from Stillwater River at Crowley Road, Northwest of I-190. The downstream sample was taken at an USGS automatic monitoring station, number 01095220, which is on Muddy Pond Rd at the Stillwater River, East of I-190. The station itself collects measurements of specific conductance at 25°C, water levels, pH, and precipitation.

3.2.1.2 Samples

We collected samples to test for a specific set of metals, specific conductance, pH and TSS. Multiple samples were taken on multiple days, to obtain comprehensive readings for the locations. The date, time, weather (rainfall data), and location were also documented. TSS samples were collected in one liter bottles. Specific conductance and pH were collected in one 250 milliliter bottle. Metal samples were collected in 250 milliliter bottles. Soil was also collected in 250 milliliter bottles but had to undergo a drying process before testing.

The following metals were analyzed: Aluminum (Al), Arsenic (As), Calcium (Ca), Chloride (Cl), Chromium (Cr), Copper (Cu), Cadmium (Cd), Chromium (Cr), Cobalt (Co), Iron (Fe), Lead (Pb), Manganese (Mn), Magnesium (Mg), Nickel (Ni), Potassium (K), Sodium (Na), Vanadium (V), and Zinc (Zn). These are common metals found in road runoff as documented in the study conducted by Smith and Granato, "Quality of Stormwater Runoff Discharged from Massachusetts Highways, 2005–07." The research included many of these elements which helped our team narrow down which metals to analyze in the water, soil and groundwater samples.

The metals that are from road salt remnants are: Ca, Cl, Mg, and Na. Learning what the MassDOT uses on the roads during the winter on I-190 near the Wachusett Reservoir helped our team compile this list (Kenna, 2016).

Nutrients were not analyzed for this project because the DCR already had detailed information on nutrients in this area. Nutrients include phosphorus, potassium, and sulfur.

3.2.2 Storm Selection

Our team worked with the DCR employee, Steve Sulprizio, to determine what storms would be suitable for sampling. The main requirements for the storm selection process included the storm being at least a 0.5 inch storm and the storm aligning with sampling during daylight. Additionally, Steve provided us with the times for the start, peak, and end of the storm so we could plan our sampling accordingly.

3.2.2.1 Sampling Timeline

The collected samples were dated and individually numbered and the number of samples taken from each site were recorded. A table was developed specifying sample number, sample location, sample time/date, and what the sample would be tested for. Table 1 provides a basic outline of

when certain samples were collected and tested. We collected multiple samples to ensure an overview of the basin which helped us then understand the efficiency.

TABLE 1: SAMPLE ITINERARY

Day	11/2	11/15	11/16	11/29	12/1
Weather	No Precipitation	Precipitation	No Precipitation	Precipitation	No Precipitation
Task	Collected soil samples and dry stream samples	Collect runoff and surface water samples	Collect groundwater samples	Collect runoff, surface water samples, and stream samples	Collect groundwater samples

3.2.3 Field and Lab Procedures

The procedures and supplies used in the field to collect soil, water from the stream, runoff, and groundwater samples are explained in greater detail below. Laboratory analysis was completed for all the samples collected to further understand the characteristics of each sample through tests of specific conductance, pH, TSS, and levels of metals present. Through the mass spectrometry machines, the ICPMS Machine, and the ICS Machine, it was determined if a level of metal present seems high or hazardous to water quality. More details of the methods used to complete these lab tests can be found in Appendix D: Lab Procedures.

3.2.3.1 Soil

Soil was collected in the project basin at various locations and depths as described in Table 2. The soil samples were brought to the lab to be analyzed for metals and salts.

TABLE 2: SOIL COLLECTION SUPPLIES AND PROCEDURE

Supplies	Procedure
<ul style="list-style-type: none">• Stainless steel shovel• Coring device• 250-mL Plastic sample bottles (one per sampling location)• Piece of notebook paper	<ol style="list-style-type: none">1. Remove topsoil with shovel2. Use coring device to dig deeper into the soil as seen in Figure 83. Pull coring device out of ground4. Pour soil in the bottom of the coring device onto the piece of paper5. Funnel the soil into the sample bottle6. Take measurements of the depth of the soil samples



FIGURE 8: CORING DEVICE IN SOIL

3.2.3.2 Water from Stream

Three water samples were collected as described in Table 3 from the Stillwater River at an upstream and downstream location from the project basin to be used as a comparison. 1 L of water was collected for TSS, 250 mL was collected to measure specific conductance and pH, and 250 mL was collected to test for anions and elements in the lab.

TABLE 3: WATER COLLECTION SUPPLIES AND PROCEDURE

Supplies	Procedure
<ul style="list-style-type: none">• 1-L Plastic sample bottle (one per sampling location)• 250-mL Plastic sample bottle (2 per sampling location)• Thermometer• Cooler	<ol style="list-style-type: none">1. Rinse out sample bottle with river water three times2. Completely submerge sample bottle in the river until the bottle is completely full, as seen in Figure 93. Measure temperature of river with thermometer4. Bring sample bottles back to lab for analysis in a cooler



FIGURE 9: SUBMERGED SAMPLE BOTTLE

3.2.3.3 Construction of Weir

To prepare for the collection of runoff during a storm event and determine flow rate, we constructed a Cipolletti weir and set up sandbags to direct and control the runoff with the help of the DCR as described in Table 4.

TABLE 4: WEIR CONSTRUCTION SUPPLIES AND PROCEDURE

Supplies	Procedure
<ul style="list-style-type: none">● Piece of wood● Measuring tape● Pencil or pen● Circular saw● Rafter square● Level● Sandbags	<ol style="list-style-type: none">1. Measure the length and height of the piece of wood2. With the use of the <i>Discharge of Standard Cipolletti Weirs in ft³/s</i> table found on the United States Bureau of Reclamation website, determine the amount of head needed to support the rate of discharge3. Use a measuring tape, rafting square, and pencil to draw the required dimensions on the board, as seen in Figure 104. Use a circular saw to cut out the drawn dimensions5. Place sandbags, filled with soil from the project basin, in a format that supports the weir and builds a wall to trap runoff as shown in Figure 11



FIGURE 10: WEIR OUTLINE

FIGURE 11: SETUP OF WEIR WITH SANDBAGS

3.2.3.4 Runoff

During a storm event samples were collected about every half hour from the project basin, with the first sample being collected the moment the runoff overflowed the weir. 1 L of water was collected for TSS, 250 mL for specific conductance and pH and 250 mL for anions and elements. The level of the water and the length of the weir were documented to later determine the flow rate of the runoff at varying times. The supplies and procedures can be seen in Table 5.

TABLE 5: RUNOFF COLLECTION SUPPLIES AND PROCEDURE

Supplies	Procedure
<ul style="list-style-type: none">● 1-L Plastic sample bottles● 250-mL Plastic sample bottles● Water gauge● Staff gauge● Rain gage● Weir● Thermometer● Cooler	<ol style="list-style-type: none">1. During storm collect runoff that has pooled near the weir as shown in Figure 122. Rinse bottles 3 times with water3. Submerge bottle underwater to fill4. Take a 1L sample and two 250 mL samples5. Document the level of water in the rain gauge6. Measure height of the runoff with staff gauge7. Measure the temperature of the runoff with a thermometer8. Bring samples back to lab in cooler



FIGURE 12: STORM RUNOFF POOL

3.2.3.5 Construction of Piezometers

To prepare for the collection of groundwater after a storm event, we constructed piezometers and placed them in the ground at various locations in and around the project basin as described in Table 6. They were placed at a depth of one to two feet down in the soil.

TABLE 6: PIEZOMETERS CONSTRUCTION SUPPLIES AND PROCEDURE

Supplies	Procedure
<ul style="list-style-type: none"> ● Stainless steel shovel ● Coring device ● Measuring tape ● PVC pipes ● PVC pipe caps ● Handsaw ● 1 Metal poll piezometer 	<ol style="list-style-type: none"> 1. Cut 3 ft. section of pipe 2. Saw 1 in slits in the bottom 6 in of the pipe as seen in Figure 13 3. Insert a cap into both ends 4. Remove topsoil with shovel 5. Use coring device to dig deeper 6. Measure depth of the hole and record location 7. Place piezometers in the hole 8. Collect small stones and place them around piezometer to prevent clogging 9. Fill in and back hole with removed soil as shown in Figure 14



FIGURE 13: CUTTING PIEZOMETER SLITS

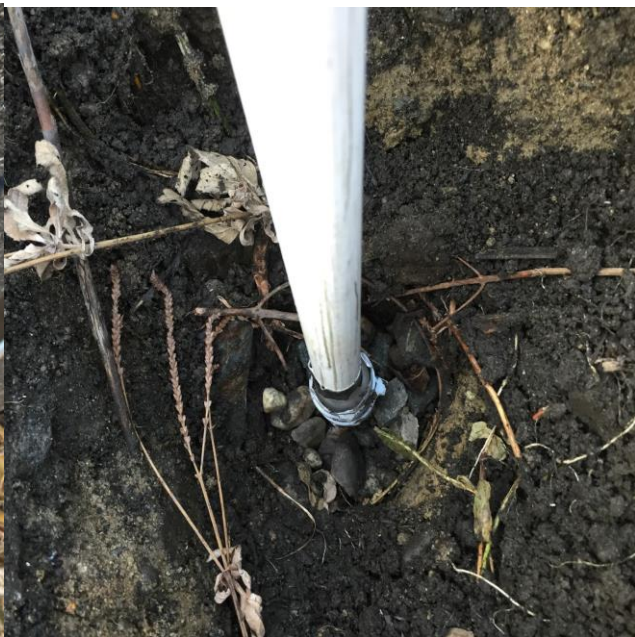

FIGURE 14: PIEZOMETER IN SOIL

3.2.3.6 Groundwater

Water that accumulates in the project basin eventually evaporates or infiltrates into the ground. To determine the quality of the water that infiltrated, groundwater within and near the project basin was collected using the piezometer. A groundwater sample of 250 mL was collected for TSS, another sample of 250 mL for specific conductance and pH and a third sample of 250 mL for metals at each location as described in Table 7. Determining what was in the groundwater helped our team comprehend the movement of water through the basin.

TABLE 7: GROUNDWATER COLLECTION SUPPLIES AND PROCEDURE

Supplies	Procedure
<ul style="list-style-type: none">● GeoPump 2 made by Geotech Environmental Equipment Inc.● 4' Plastic tubing● 250-mL Plastic sample bottles (3 per location)● Cooler	<ol style="list-style-type: none">1. Insert or attach plastic tubing to piezometer2. Hook GeoPump 2 up to the tubing3. Connect the pump to a battery and turn on4. Take three flushes of groundwater and discard5. Take three samples using 250-mL sample bottles as seen in Figures 156. Unhook pump and leave piezometer7. Bring samples back to lab in cooler



FIGURE 15: COLLECTION OF GROUNDWATER SAMPLES WITH GEOPUMP

3.2.4 Desktop Analysis

Once results were produced through field and lab work, our team interpreted the results. To achieve this we created graphs using Microsoft Excel of all the results and determined what graphs showed us a trend, varied levels, or correlations. Graphs for our final analysis can be found in Section 4.4 Stormwater and Basin Characteristics and additional graphs can be found in Appendix I: Graphs. In addition to analyzing our lab results, a desktop design analysis was conducted to gain a greater understanding of the current project basin to be used in the optimal basin design. This desktop design analysis consisted of calculating flow rates for the runoff during Storm 1 and Storm 2 to determine the discharge from the drainage area going into the project basin. Flows were calculated via two different methods. The first method used a mathematical equation specific to the type of weir used, a Cipolletti weir. The second method was with the computer software program HydroCAD®.

3.2.4.1 Flow Rate Cipolletti Weir

Section 3.2.3.3 Field and Lab Procedures stated the procedure followed to create the weir. Equation 1 was used to calculate the flow rate during Storm 1 and Storm 2, specific to the Cipolletti (trapezoidal) weir. It takes the level of water, height of the weir and length of weir (L) into consideration for each measurement of runoff collected. Refer to Appendix F:1 Cipolletti Weir Hand Calculations to see the calculations of flow rates for each sample that was collected during the storms.

$$Q = 3.367 * L * h^{\frac{3}{2}}$$

EQUATION 1

$$\textit{head}(h) = \textit{water depth behind weir} - \textit{depth of weir crest}$$

EQUATION 2

$$L = \textit{length of weir}$$

EQUATION 3

3.2.4.2 HydroCAD®

HydroCAD® was used to model the hydrology of the project drainage area and basin. Using HydroCAD® allowed our team to create hydrographs for the entirety of the storm events and theoretical storms, not just for the samples we had collected. To model the hydrology of the project drainage area and basin a series of 2 nodes was used. A subcatchment node (1S) was used for the drainage area and a pond node (1P) was used for the project basin as seen in the final diagram in Figure 16.

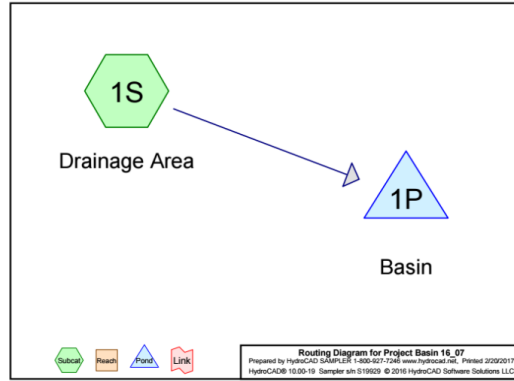

FIGURE 16: PROJECT BASIN ROUTING DIAGRAM

The parameters used in node 1S were the area, curve numbers (CN) and time of concentration (Tc). To determine the area, the drainage area was divided up by land use with soil type using ArcGIS and the acreage for each was recorded in the table as seen in Figure 17. The CN is a parameter representing the direct runoff and infiltration of an area. To find the CN value associated with each land section the "Lookup CN feature" on HydroCAD© was used as seen in Figure 17. The final weighted CN used was 88. To determine the Tc, the sheet flow, shallow concentrated flow, pipe channel, and parabolic channel methods were used. The sheet flow was used for the plane grass surface. The shallow concentrated method was used instead of sheet flow for the grassed waterway ditch because its flow length exceeded 300ft and it is assumed that at over 300ft sheet flow becomes shallow concentrated flow (United States Department of Agriculture, 1986). The pipe flow method was used for the concrete pipe and the parabolic channel method was used for the concrete ditch. ArcGIS elevations and distances were used in hand calculations to determine slopes. The final Tc used was 22.9 minutes. This Tc generally agreed with what we observed while in the field for when the storm started and when we began to see the runoff flow into the basin.

The screenshot shows two overlapping dialog boxes in the HydroCAD software. The background dialog is 'Edit Subcat 1S - Project Basin 16_07' with tabs for 'General', 'Area', 'Tc', and 'Notes'. The 'Area' tab is active, showing a table with columns 'Line', 'Area (acres)', 'CN', and 'Description'. Below the table, 'Total Area: (acres)' is 7.400 and 'Weighted CN:' is 88. A 'Lookup CN...' button is visible. The foreground dialog is 'Select Curve Number' with a table listing various curve numbers and their descriptions. The table has columns for 'line', 'Description', 'Condition', and four columns labeled 'A', 'B', 'C', and 'D'. The value '98' is highlighted in the 'A' column for line 9.

line	Description	Condition	A	B	C	D
w2	Classified as Impervious		98	98	98	98
w3	Classified as Pervious	0% imp	98	98	98	98
6	Impervious Areas					
7	Paved parking lots, driveways		98	98	98	98
7a	Unconnected Impervious		98	98	98	98
7b	Roofs		98	98	98	98
7c	Unconnected Impervious		98	98	98	98
8	Streets and roads					
9	Paved; curbs and storm sewers		98	98	98	98
10	Paved; open ditches (w/ROW)	50% imp	83	89	92	93
11a	Gravel (w/o right-of-way)		96	96	96	96
11	Gravel (w/ right-of-way)		76	85	89	91
12	Dirt (w/ right-of-way)		72	82	87	89
13	Urban Districts	impervious				
14	Commercial & business	85% imp	89	92	94	95
15	Industrial	72% imp	81	88	91	93

FIGURE 17: PROJECT BASIN HYDROCAD© AREAS AND CN

Node 1P parameters included the fact that the project basin was a stormwater detention pond, the storage parameters that were found using the construction plans and ArcGIS, and the outlet parameters. For the model, there were two outlets for 1P: Exfiltration and the Broad-crested Rectangular Weir. For exfiltration, the conductivity was chosen by a weighted average of loamy sand and sand from Table 13 to be 5.34. A wetted area was used for exfiltration to include horizontal exfiltration. A summary of the values can be found in Table 8.

TABLE 8: NODE 1P PARAMETERS

Parameter	Value
Storage: Description	Prismatoid
Storage: Invert Elevation	421'
Storage: Bottom Width	65'
Storage: Bottom Length	135'
Storage: Height	5'
Storage: Side-Z (rise/ run)	0.5
Outlet Weir: Invert Elevation	426'
Outlet Weir: Crest Length	50'
Outlet Weir: Crest Breadth	15'
Exfiltration: Conductivity	5.34 in /hr.
Exfiltration: Ground Elevation	390'

In order to create hydrographs for our specific storms we had to input the storm data into the HydroCAD® rainfall directory using the edit function as seen in Figure 18. The duration of storm was 12 hours and the total rainfall was used as the depth for both storms. The antecedent moisture condition (AMC) is the moisture level in the ground immediately prior to the storm according to the HydroCAD® Stormwater Modeling System Version 10 Owner's Manual. The AMC used was 2, which denotes normal soil as it is used in most design work (HydroCAD®, 2011).

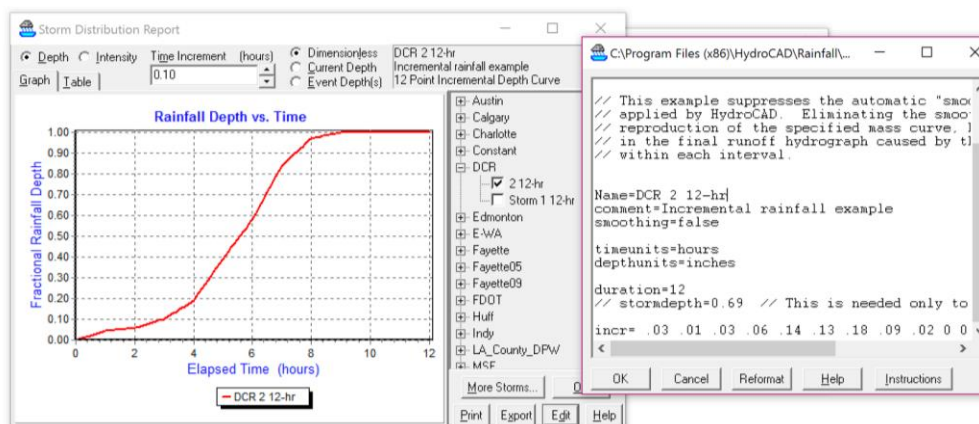

FIGURE 18: INPUTTING STORMS

Chapter 4: Results

The project included the evaluation of the impacts of a stormwater treatment basin on water quality, specifically the impact of the stormwater runoff from I-190 on the Wachusett Reservoir. Once the project basin was selected, we focused on understanding the layout of the basin from its point of construction. Other topics of research included the drainage area to understand the movement of runoff and the different land uses and soils affecting the point of infiltration. The results of this evaluation included detectable levels of Na, Mg, specific conductance and TSS. Na and Mg were examined more closely because they had detectable levels that moved through or were captured within the basin.

4.1 Project Basin

Basin 16:07 was selected as the project basin. As seen in Figure 19, the project basin is located in the southwest quadrant of the intersection of I-190 and Greenland Road in Sterling, Massachusetts near the Sterling Airport and Muddy Pond. Access to the basin can be gained from Greenland Road. The process of selecting a project basin and details specific to the chosen project basin, Basin 16:07, can be found in the following sections.

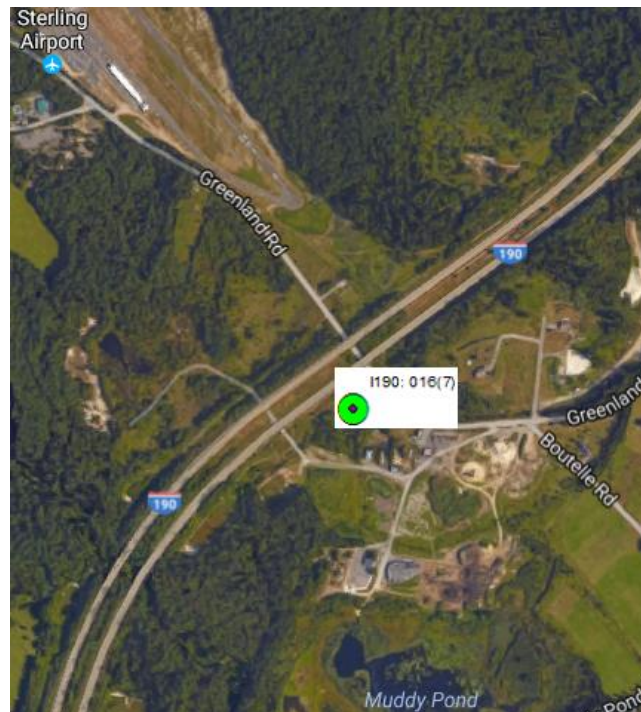

FIGURE 19: PROJECT BASIN (GOOGLE, 2017)

4.1.1 Selection of Basin

Basin 16:07 was chosen after evaluating 12 basins on accessibility, direct inlet of runoff, size, drainage area, and location relative to monitoring stations. Figure 20 provides a summary of the characteristics that were considered and which basins moved on to each level of evaluation.

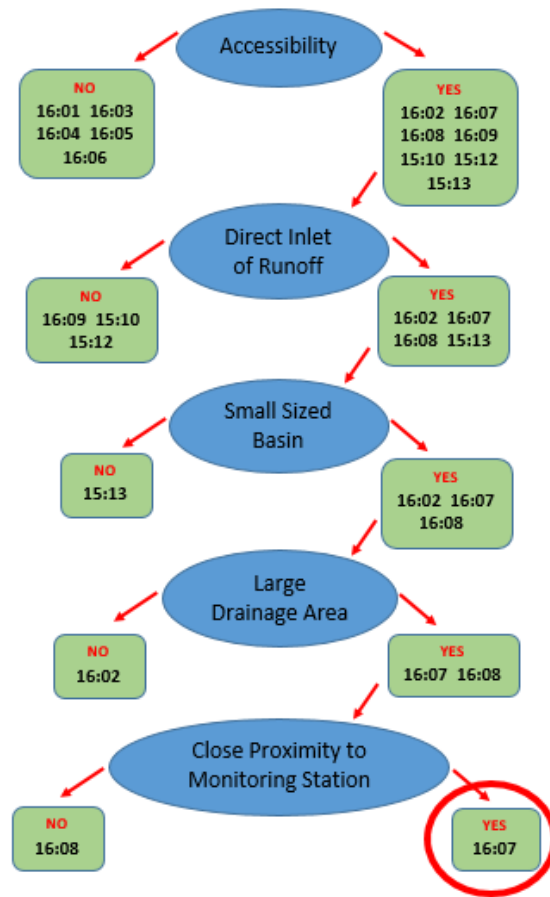

FIGURE 20: BASIN SELECTION

4.1.2 Basin Drainage Area

The drainage area for Basin 16:07 was calculated to be 7.40 acres, as seen in Figure 21, based on the construction plans included in Appendix E: Drainage Area and ArcGIS.

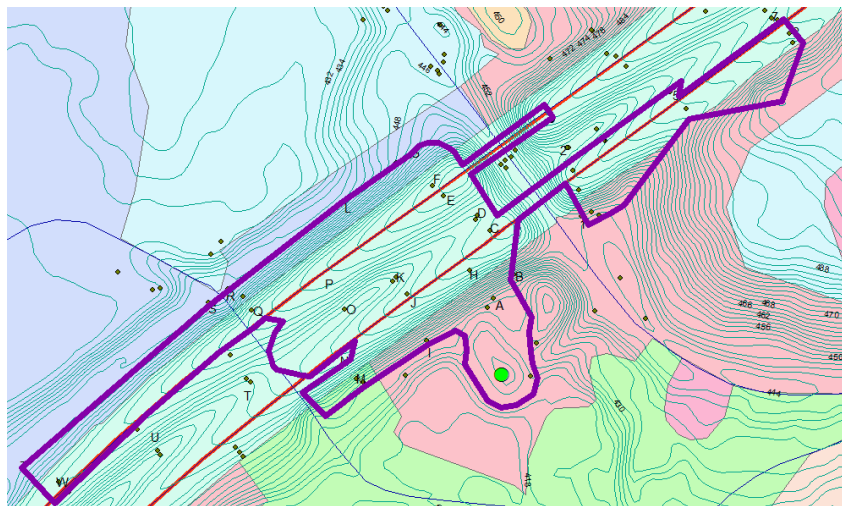

FIGURE 21: PROJECT BASIN DRAINAGE AREA

4.1.3 Layout of Basin

Sedimentation pools were built in the 1970s to collect sediment runoff during the construction of I-190. The basins were modified into stormwater treatment basins after construction was finished to protect the Wachusett Reservoir from pollutants and hazardous spills on the roadway. There are two ways by which water exits I-190. One option is through catch basins, which capture and transport the runoff via pipes to a concrete ditch. The other option is water running off of the road, down the embankment to a concrete ditch. Basin 16:07 utilizes both of these options. Once the water flows along the concrete ditch, it enters the concrete inlet of the basin. The inlet ditch funnels the water and deposits it into Chamber 1 of the basin, as seen in Figure 22.

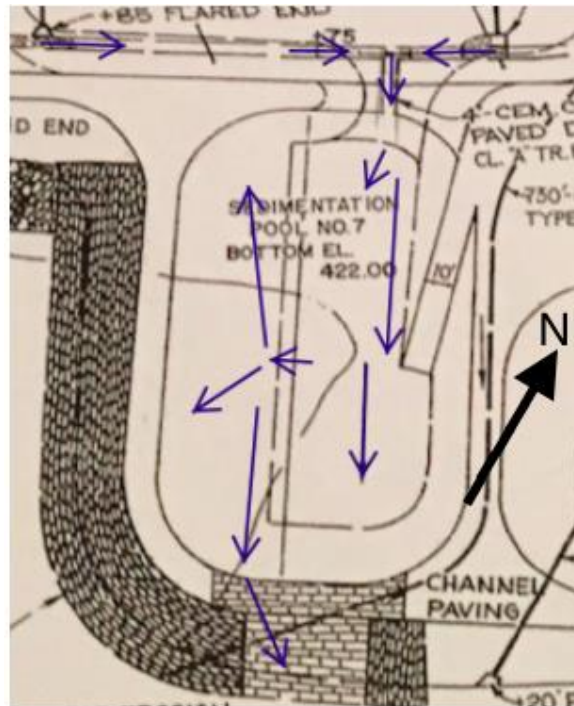

FIGURE 22: OVERVIEW OF BASIN

Chamber 1 is made to support large volumes of runoff water as seen through observations made during field visits, Appendix G:1 Field Visit 9-26-2016. It was noticed during the storms that the water would pool in Chamber 1 and allow suspended solids to sink before water moved to Chamber 2 when Chamber 1 reached maximum storage. Then as the water levels increased throughout the basin, Chamber 2 would fill. To separate the two chambers and help slow flow, Basin 16:07 uses a Type 2 Barrier, which includes a long concrete wall with a wooden panel gate weir. A sand bottom and berm in Chamber 2 promotes infiltration. When water levels exceed the height of both chambers, the water is directed by the grading of the basin to flow out of the

chambers over the spillway of the basin. Figure 22 gives a visual representation of how the water moves in the basin.

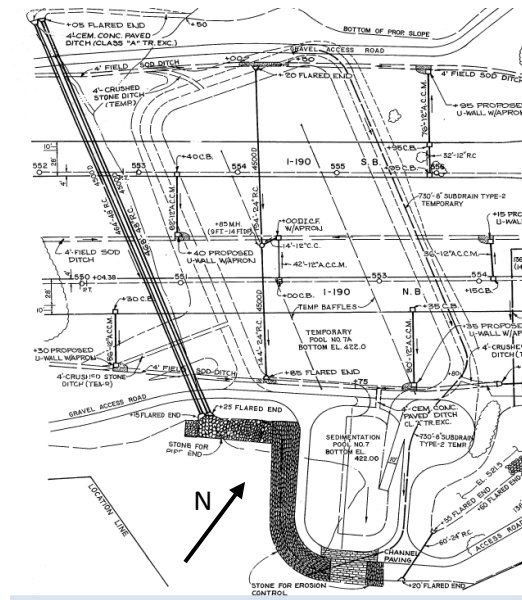

FIGURE 23: ORIGINALLY CONSTRUCTED SEDIMENT BASIN

POOL NO.	TEMPORARY POOL LOCATION	SCHEDULE				ELEVATION		
		DIMENSIONS (FT.)				BOT. OF POOL	TOP OF BERM	SPILLWAY
L	W	D	LS					
1-A	504+00 @ NB	390	85	5.0	---	490.0	496.0	495.0
2-A	518+00 @ NB	230	130	5.0	---	450.0	456.0	455.0
3-A	528+00 @ NB	190	150	5.0	---	414.0	420.0	419.0
---	---	---	---	---	---	---	---	---
---	---	---	---	---	---	---	---	---
7-A	553+00 @ NB	360	180	5.0	---	422.0	428.0	427.0
9-A	19+40 - 22+25 @ RYE-140	244	125	3.1	---	493.8	497.9	496.9

FIGURE 24: ORIGINAL SEDIMENT BASIN DIMENSION CHART FROM PLANS

Basin 16:07 was originally built for the construction of I-190 in the late 1970s to capture construction-related sediment and turbidity. The basin originally extended northerly where I-190 is currently located, as seen in Figure 23. Figure 24 shows the dimensions of Basin 16:07, boxed in pink, at its post-constructed size. However, the pool dimensions changed when it was modified into a stormwater treatment basin and might have changed slightly again due to maintenance in 2004. Current dimensions were taken during field visits. Additionally, the basin was built with a ramp so maintenance vehicles could access the basin. The goal of the basin was to filter the water through physical treatment processes, such as sedimentation and infiltration before the water left the basin. In Appendix B: Layout, multiple figures illustrate the layout, structure, and design of the original design basin.

4.2 Hydrograph

A hydrograph shows the relation between flow during a storm event and time. Understanding the discharge of the runoff allowed for a more thorough understanding of what the project basin was capable of supporting and the necessary process of movement and infiltration through the basin. The results from the flow calculations and total storage area of the basin can be found in the following sections.

4.2.1 Weir Design & Construction

A Cipolletti weir was used in the collection of runoff samples in the project basin. A rough estimate of the anticipated flow was needed to establish the weir length. The table, *Discharge of Standard Cipolletti Weirs in ft³/s*, from the United States Bureau of Reclamation provides information regarding the relationship between head, weir length and the discharge rate. The weir length had to be between 2 and 3 feet and the flow rate had to be approximately 5 cubic feet per second (cfs). Using the table, the head was determined to be 0.7 feet. Then the weir trapezoidal shape was made with a 4:1 slope for 5 cfs with 2.5 feet length and 1.25 feet on each side to be secured with sandbags.

4.2.2 CN Values and Tc

The drainage area was divided into segments according to land use and correlating soil type. Soil type ranged from "A" being a porous sand through "C" being a hard-packed glacial till. The land use, soil type, and area for each segment within the drainage area were taken from ArcGIS and then taken into account to find the CN values for the drainage area on HydroCAD© . A summary of all the values can be found in Table 9. The total drainage area is 7.40 acres resulting in an average CN of 88.

TABLE 9: ACRES AND CN VALUES

Land Use from ArcGIS	Soil Type from ArcGIS	Area (acres)	CN Value
Transportation	A	6.2	98
Brushland/Successional	A	0.535	35
Forest	A	0.535	36
Cropland	A	0.040	49
Forest	C	0.030	73
Forest	B	0.060	60

The specific path used to determine the Tc can be seen in Figure 25. The specific lengths and elevations can be seen in Table 10.

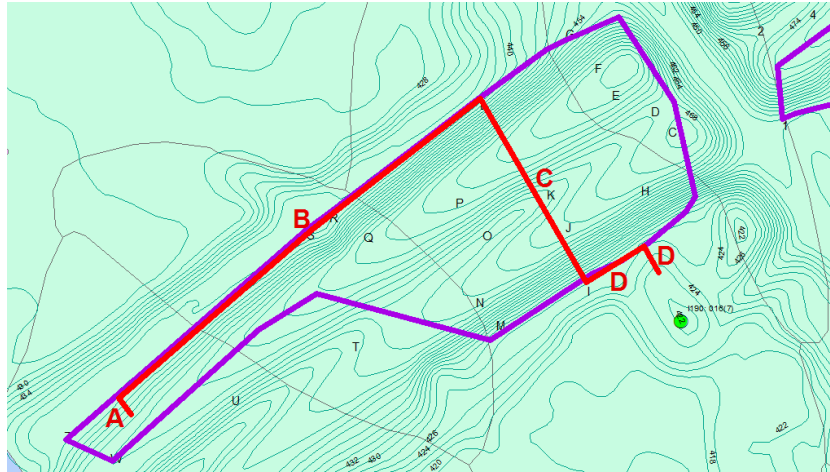

FIGURE 25: PROJECT BASIN Tc FLOW LENGTH

TABLE 10: FLOW LENGTHS AND WATERCOURSE SLOPE

	A Grass	B Sod Ditch	C Concrete Pipe	D Concrete Ditch
Start Elevation	445'	443'	440'	430'
End Elevation	443'	440'	430'	424'
Length	75'	700'	340'	150'
Slope	0.03	0.004	0.03	0.04

4.2.3 Storm Data

Samples were collected during two storms for our project to help comprehend stormwater impacts and responses in the project basin and Stillwater River.

Storm 1 had a total rainfall of 1.07 inches and occurred on Tuesday, November 15, 2016 from 12:30pm until 10:45pm, shown on Figure 26 as hour 0 until 10.25 hours. Runoff samples were collected between 2pm and 5pm in 20-30 minute intervals, shown on Figure 26 as hour 1.5 until 4.5 hours into the storm. Due to the daylight restrictions, our team was not able to collect a sample during the peak of the storm. Storm 1 captured the first flush, the beginning of the stormwater runoff which has high concentrations of contaminants compared to the rest of the storm, as seen in Figure 30.

Storm 2 had a total rainfall of 0.69 inches and took place on Tuesday, November 29th from 11am until 7:30pm, seen on the graph as hour 0 until hour 8.5. Runoff samples were collected between 3pm and 5:40pm in 20-30 minute intervals starting 4 hours into the storm until 6.75 hours into the storm. It is unknown if the first flush was captured during the storm because in Figure 31 there was no peak in contaminant levels. Stillwater River samples were also collected during this time at approximately 2:20pm and 4:15pm, seen on the graph at 3.25 and 5.25 hours after the storm started.

The hyetographs shown in Figure 26, shows a comparison of the rainfall between Storm 1 and Storm 2 over time.

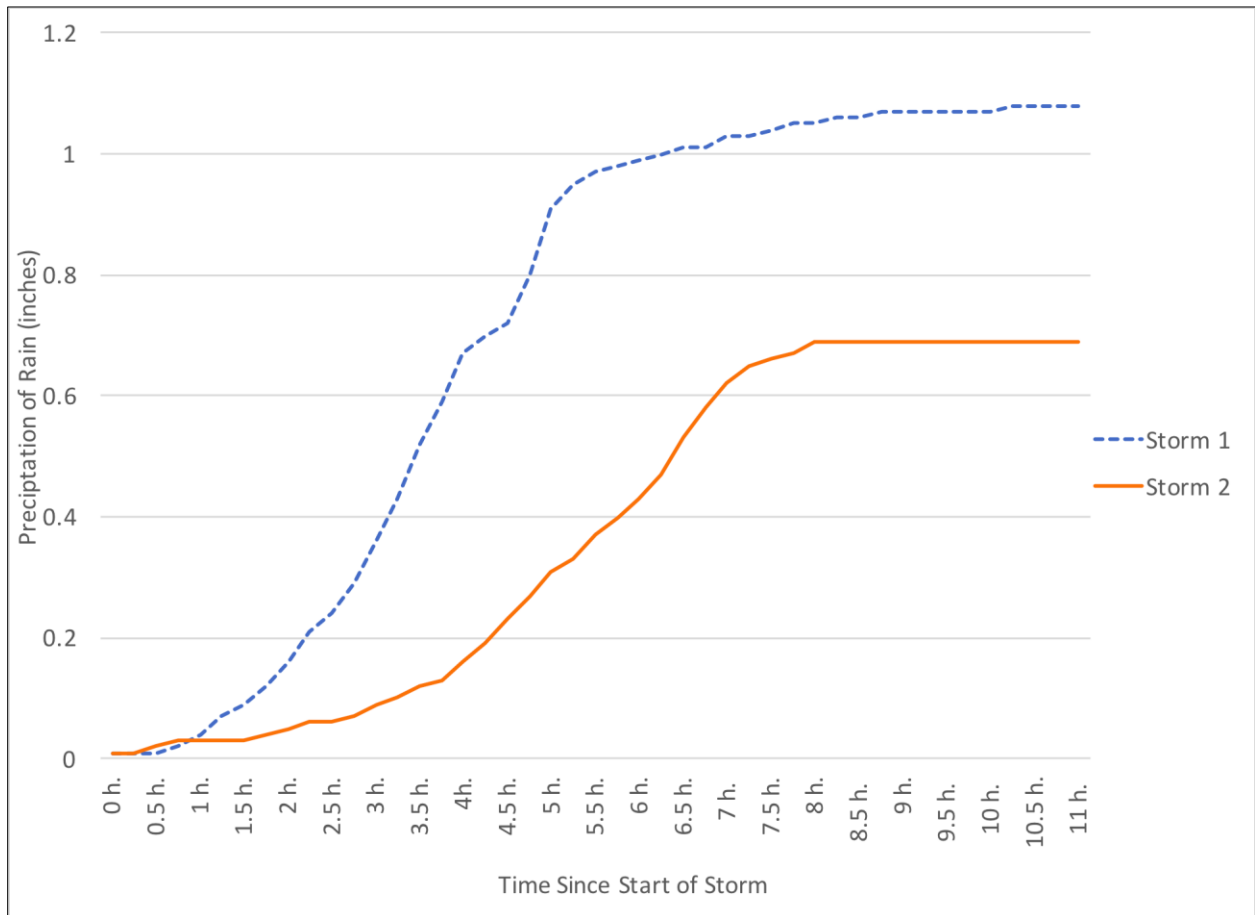

FIGURE 26: CUMULATIVE PRECIPITATION OF STORM 1 AND STORM 2

4.2.4 Mathematically Calculated Flow Rates

The flow rates mathematically calculated for Storm 1 and Storm 2 can be found in Figure 27 versus rainfall depth.

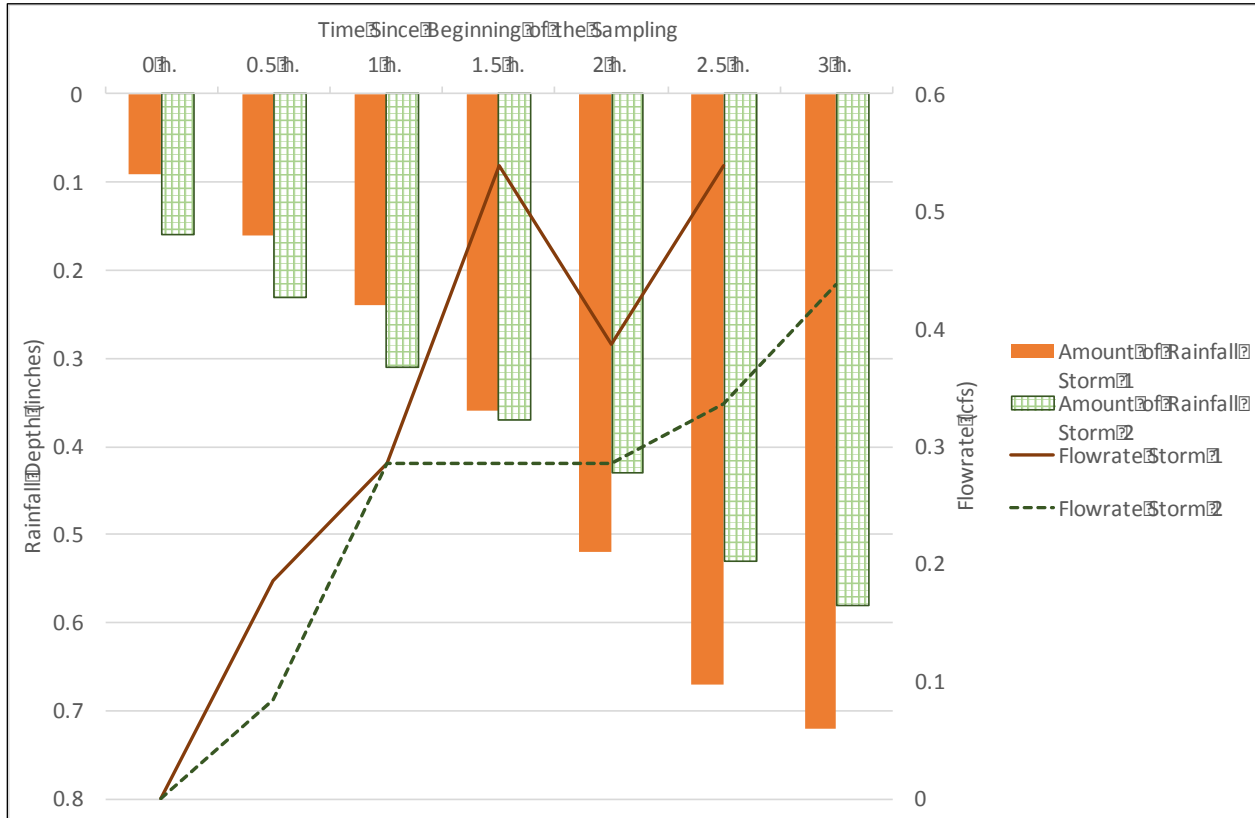

FIGURE 27: FLOWRATE AND RAINFALL FOR STORM 1 AND STORM 2 DURING SAMPLING PERIOD

4.2.5 HydroCAD® Output

The hydraulic outputs for the HydroCAD® model based on Basin 16:07 can be seen for Storm 1 and Storm 2 in Appendix F:2 HydroCAD®. The only parameter different between the two models is the storm chosen. In the hydrology output, shown in Figures 28 and 29, the furthest line back represents the basin inflow. The second line from the back represents the total outflow or the sum of the “primary” and “discharge” lines. The third line from the back represents the discharge though infiltration. All of the water leaves through infiltration for the chosen storms in the project basin. The last line, closest to the front, represents the primary outflow which is at zero since no water leaves over the outfall.

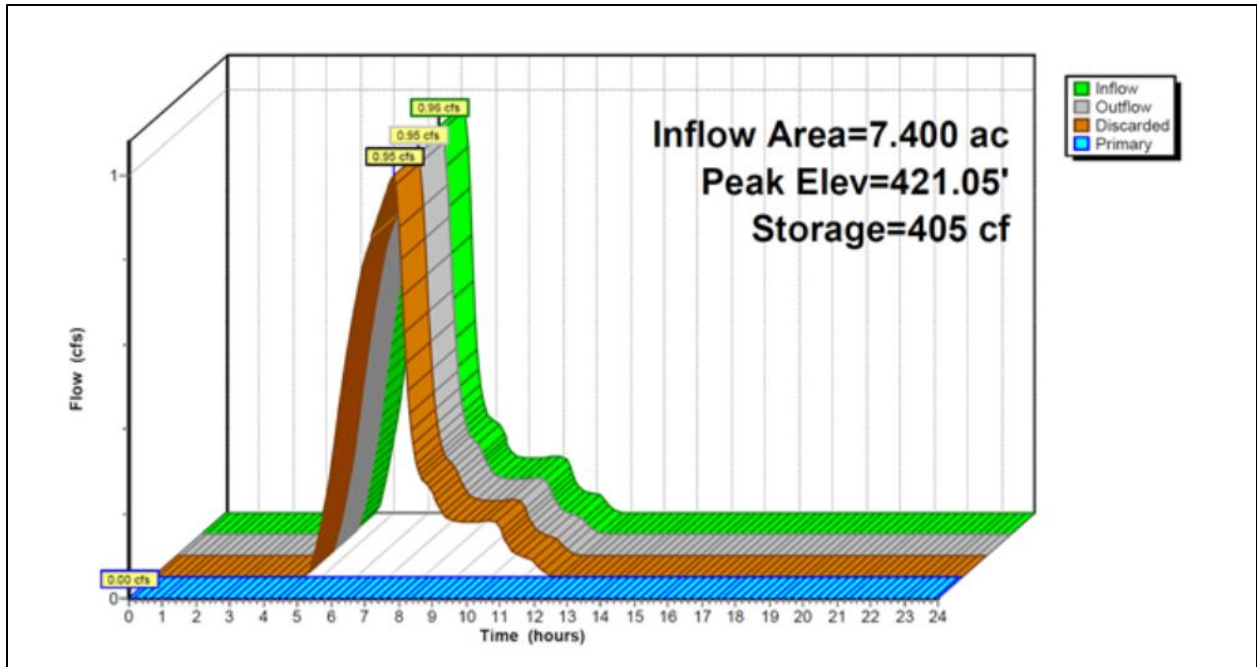

FIGURE 28: STORM 1 HYDROCAD© HYDROLOGY

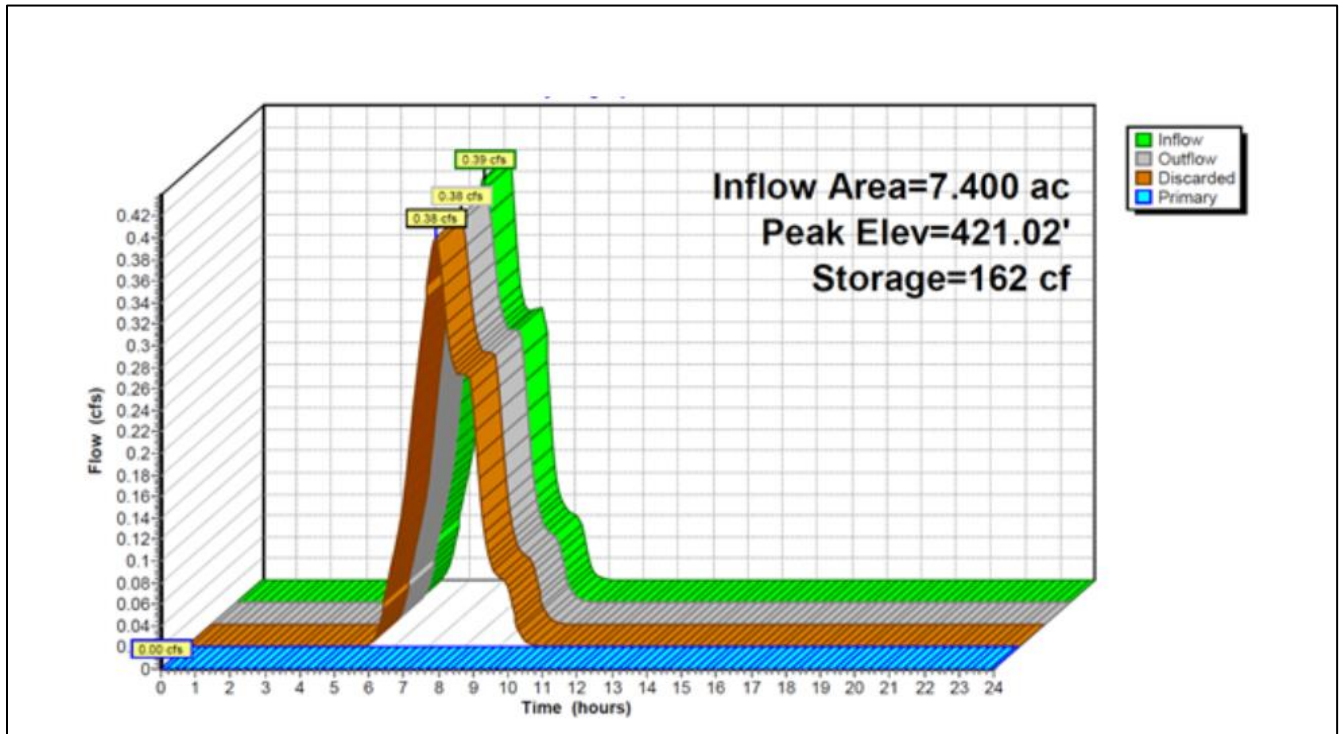

FIGURE 29: STORM 2 HYDROCAD© HYDROLOGY

4.3 Field Observations

Each time our team went to the field we took detailed notes of observations made and tasks completed and summarized them in field notes. Observations recorded included but were not limited to the weather, date, location, materials used, samples taken, and photographic evidence. These notes were used as a reference when performing analysis and writing this report, as found in Appendix G: Field Notes.

One key finding developed from the field notes from Storm 2 sample collection was in regards to groundwater collection. By the time our team collected groundwater samples two days after Storm 2 had occurred, additional rainfall had happened between the two sampling days. When we arrived to collect groundwater samples there was standing water in Chamber 1 and some had overflowed into Chamber 2. The amount of standing water in the two basins may have had some impact on the groundwater quality, although the extent of this impact cannot be fully determined.

4.4 Stormwater and Basin Characteristics

This section will discuss the analysis of the data, following the water as it enters the basin and potential travels to the Stillwater River which carries water to the Wachusett Reservoir. To gain a better understanding of the basin we chose to focus on Na and Mg. Several other metals were tested for and all the raw data can be found in Appendix H: Data Sheets. During the preliminary look of the data, graphs were made with all metals included; those graphs can be found in Appendix I: Graphs. For discussion purposes some metals were removed from the graphs due concentration levels being undetectable. Na and Mg were the two metals that were chosen to present here due to their similarities and differences in how they moved through the basin and their visibly detectable levels.

4.4.1 Runoff

Runoff, was collected during two storms at the inlet of the basin. Metals, TSS, specific conductance, and flow rates were analyzed and compared for each of the storms. Conclusions from these results began the visualization of the movement of stormwater through the basin.

4.4.1.1 Sodium in Runoff

Sodium (Na), one of the several metals that we tested for, was found to have the highest metal amount present during both storms. Due to highway treatment during the winter Na is commonly found in high amounts along the sides of roads. MassDOT regulates the amount of rock salt used on I-190. However, the local towns surrounding I-190 do not have regulations on the amount or type of rock salt they can use.

To better understand how the levels of Na increased we followed it as the storm progressed in the figures below.

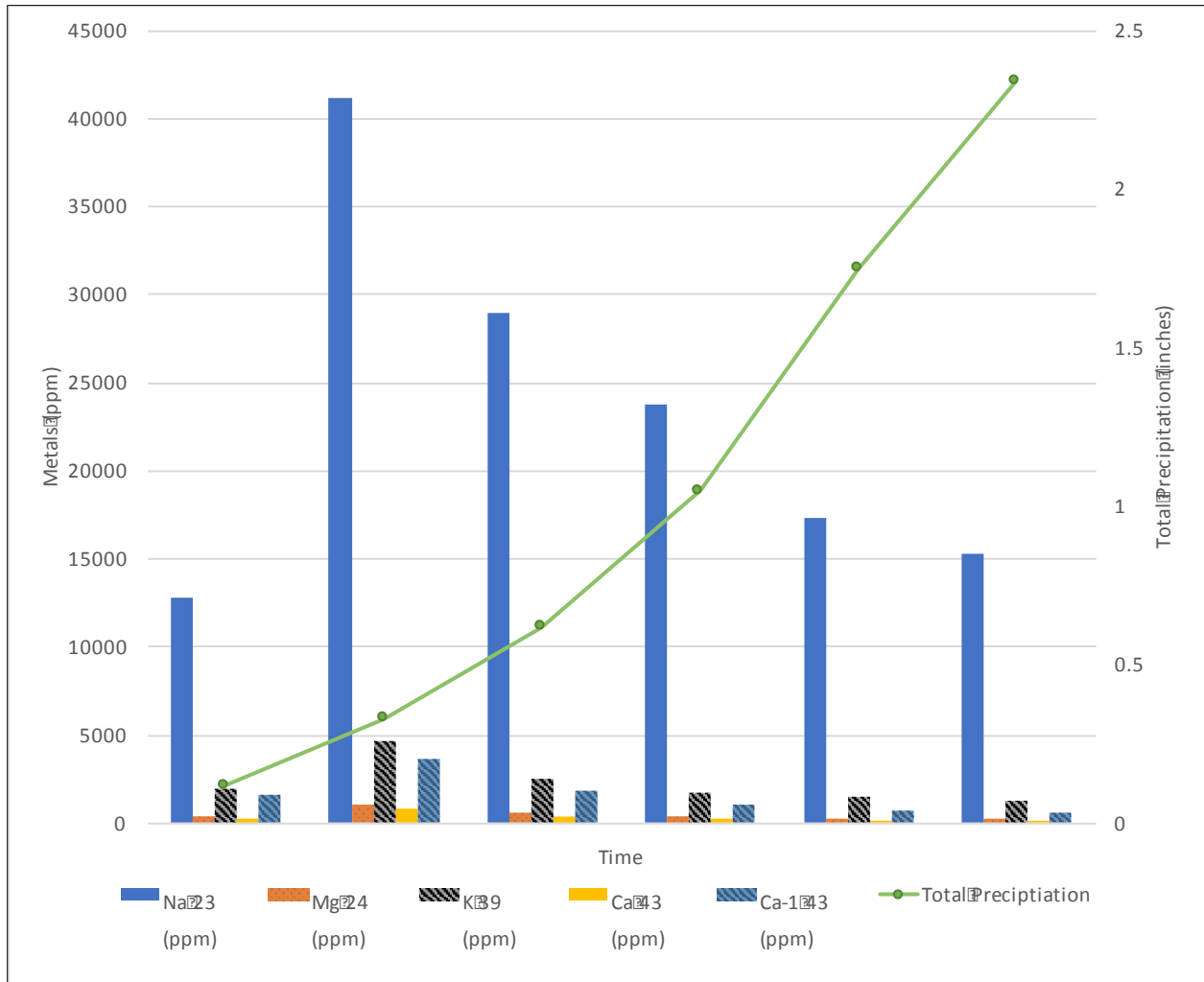

FIGURE 30: RUNOFF DISSOLVED METALS WITH TOTAL PRECIPITATION FROM STORM 1

Figure 30 shows the levels of Na in runoff during Storm 1 along with Mg, K, and Ca. These metals were shown on the figure to show the large difference in concentration between them and Na. Additional metals were tested for but were not included in Figure 30 because their results were much lower and could not be observed on this plot. Since the cumulative precipitation is overlaid on this figure, the first flush can be easily seen in the peak at 0:30. As the storm continues, the concentration of metals decreases as expected.

Figure 31 shows the levels of Na in runoff during Storm 2 along with Mg, K, and Ca. The data begins with the first flush. Figure 30 and Figure 31 have very similarly shaped figures but looking at the y-axis scale it can be seen that the amount of Na in parts per million (ppm) was much higher in Storm 2.

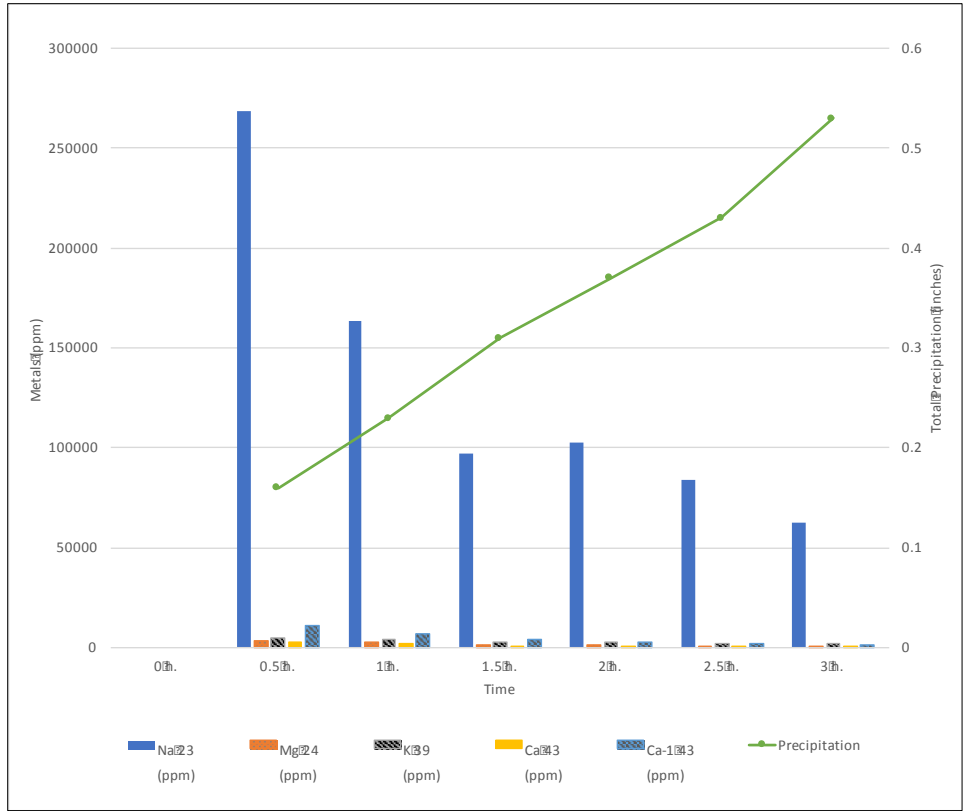

FIGURE 31: RUNOFF DISSOLVED METALS WITH TOTAL PRECIPITATION FROM STORM 2

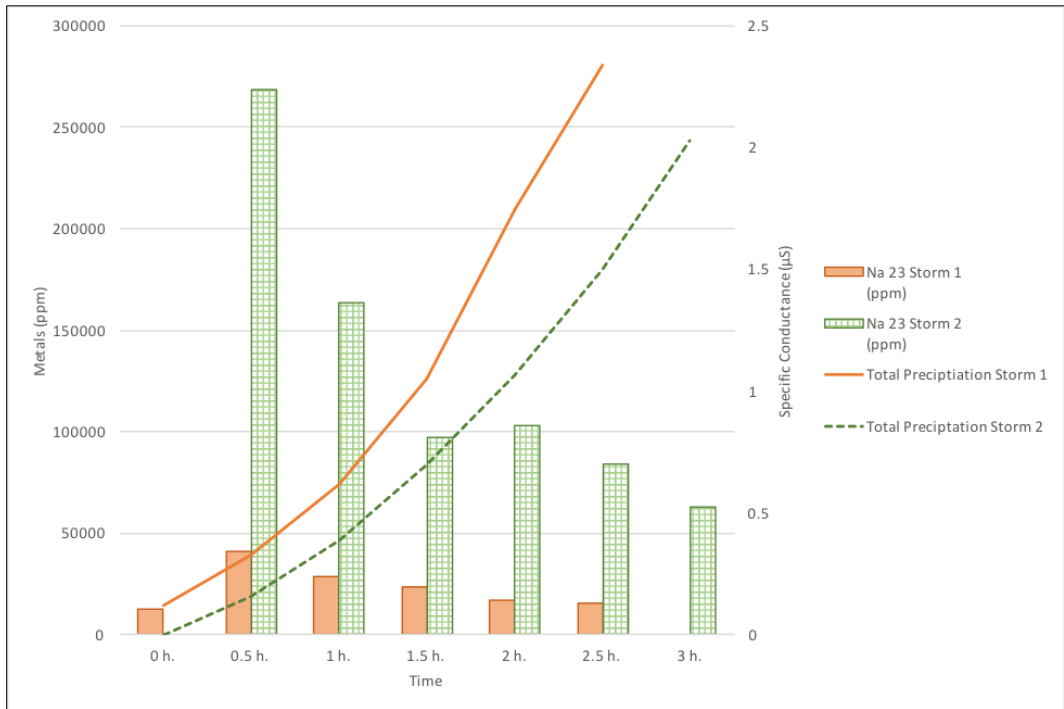

FIGURE 32: COMPARISON OF NA FOR CUMULATIVE PRECIPITATION OF STORM 1 AND STORM 2

Figure 32 shows data from both storms and through comparative analysis it can be seen that Storm 2 had a greater dissolved concentration of Na. We believe the concentration was higher during Storm 2 because during the weekend preceding the storm there was an ice warning on the roads. MassDOT applied road salt and pre-wet magnesium chloride solution on I-190 to ensure safety on the roadway. The road salt was washed off I-190 during the storm and into the project basin. Figure 32 clearly shows the impact road salt has on the amount of Na in the basin. Note that Storm 2 is offset so that both storm's first flushes are aligned.

4.4.1.2 Magnesium in Runoff

The compound magnesium chloride is used as wet pre-treatment before road salt is used on the roads. For this reason Mg was also analyzed. Mg can also be found on the roads from cars; Mg alloy is used in multiple parts of cars, such as car frames due to its light weight and high strength.

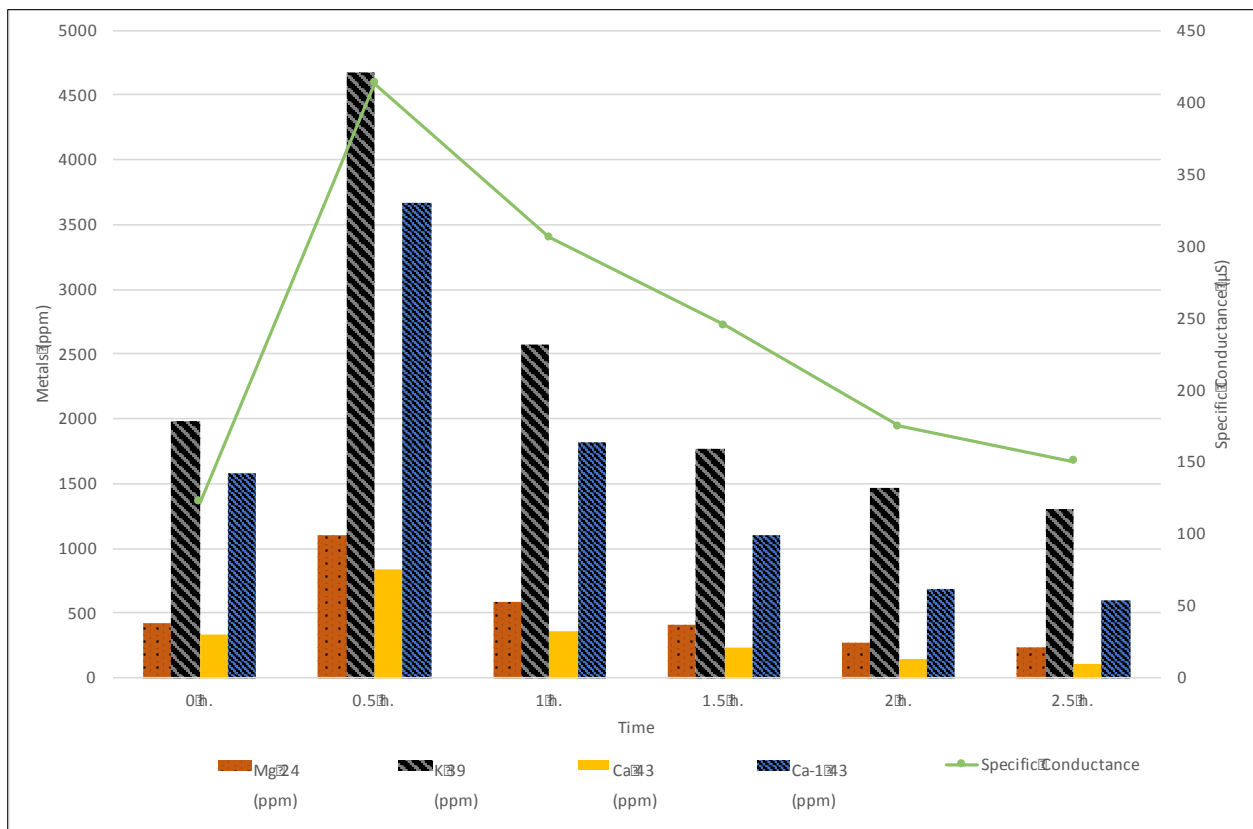

FIGURE 33: RUNOFF DISSOLVED METALS W/O NA WITH SPECIFIC CONDUCTANCE FROM STORM 1

Figure 33, shows the concentrations of Mg from Storm 1 present in the runoff. EPA regulation levels for human and organism health for consumption for Mg need to be below 50 $\mu g/L$. At the peak of Mg during the storm the runoff levels were above 1000ppm (1000mg/L). It is important to note that these samples were taken before the water entered the reservoir, before any water treatment processes.

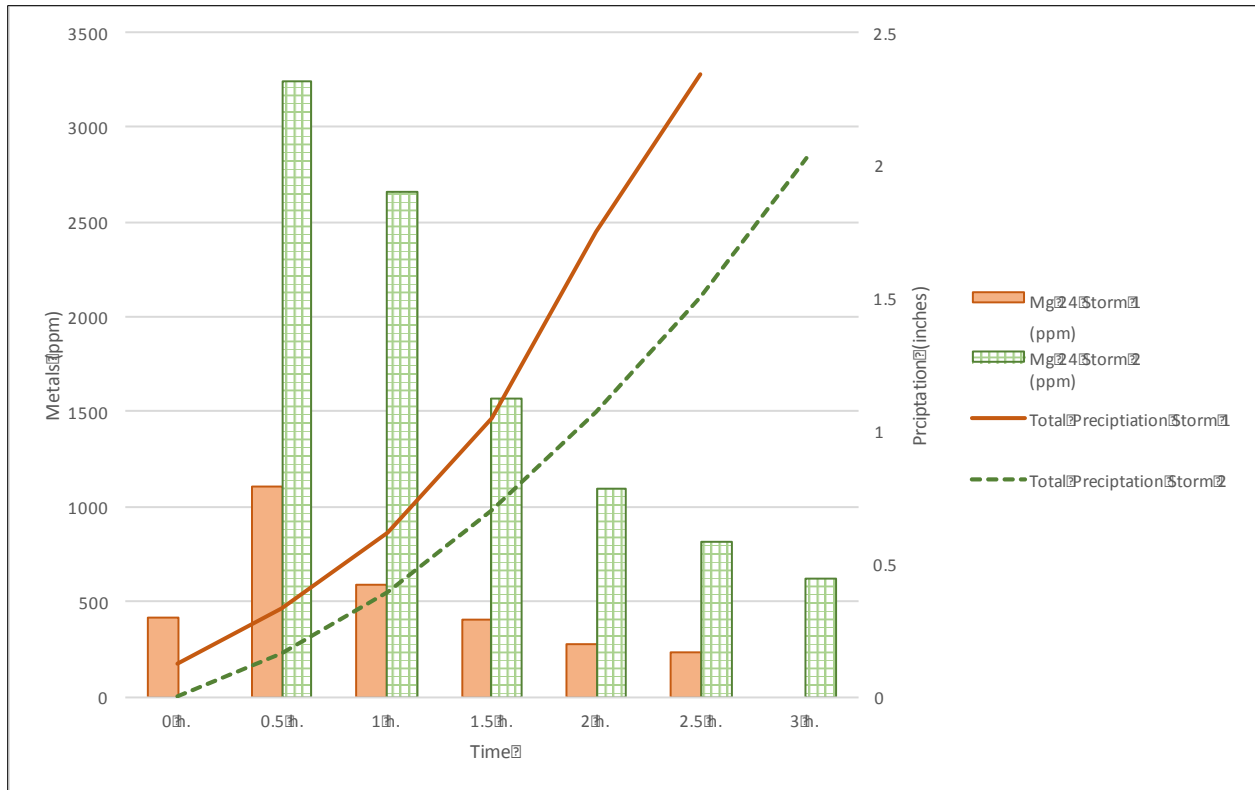

FIGURE 34: COMPARISON OF MG FOR CUMULATIVE PRECIPITATION OF STORM 1 AND STORM 2

Figure 34 shows the difference in Mg concentrations from Storm 1 to Storm 2. The levels of Mg were significantly higher in Storm 2 than Storm 1. The Mg levels at the peak of Storm 2 were at 3025 ppm (3025mg/L), which is still higher the EPA limit. Runoff is all pre-treatment however and the levels did decrease as stormwater progressed through the basin from Chamber 1 to Chamber 2, showing how the project basin was successful in trapping Mg and reducing outflow levels of Mg.

4.4.1.3 Specific Conductance and Na in Runoff

Figure 35 shows how specific conductance from Storm 1 to Storm 2 varied and how closely they matched the Na concentration levels. This revealed how the specific conductance levels decreased as the total metal concentration decreased.

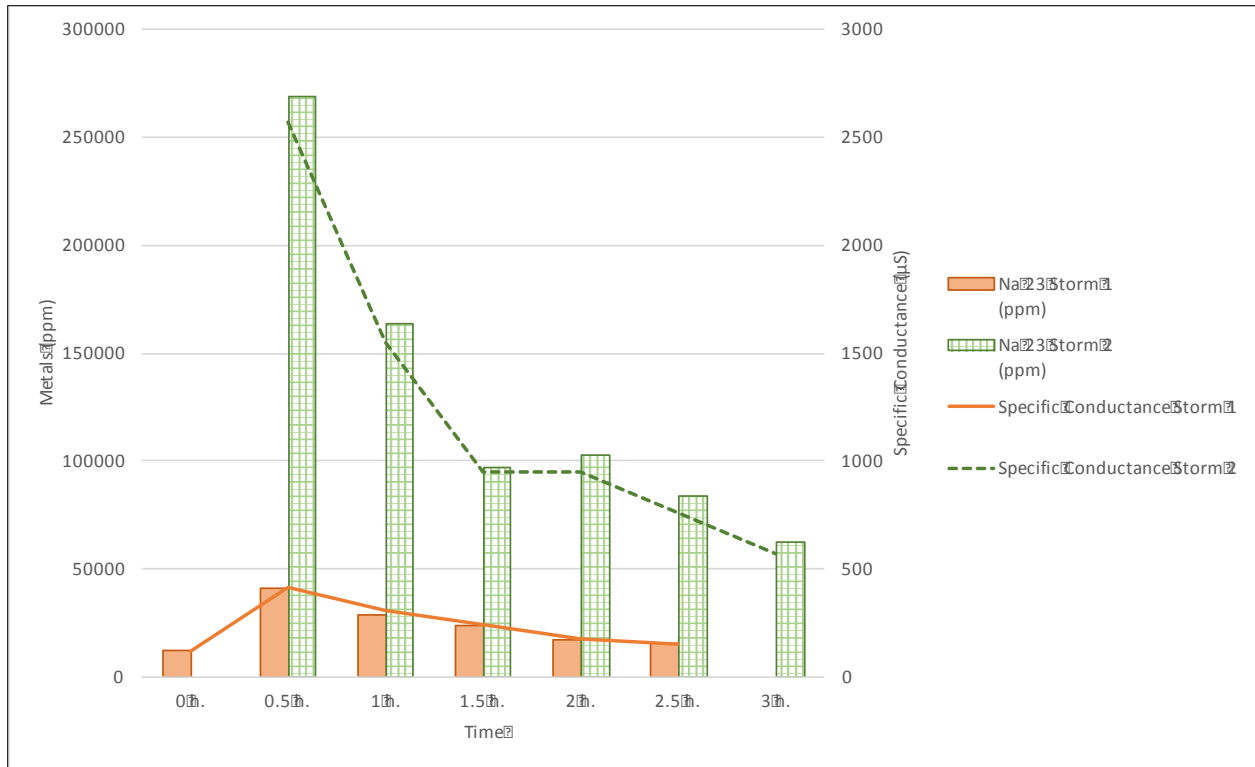

FIGURE 35: COMPARISON OF NA AND SPECIFIC CONDUCTANCE OF STORM 1 AND STORM 2

4.4.1.4 TSS in Runoff

The TSS results for runoff as modeled in Figure 36 show a similar trend for both Storm 1 and Storm 2. The TSS data for Storm 2 were off placed by one in Figure 36 since Storm 1 caught the first flush at time 0. As the storm continues, the TSS per sample decreased.

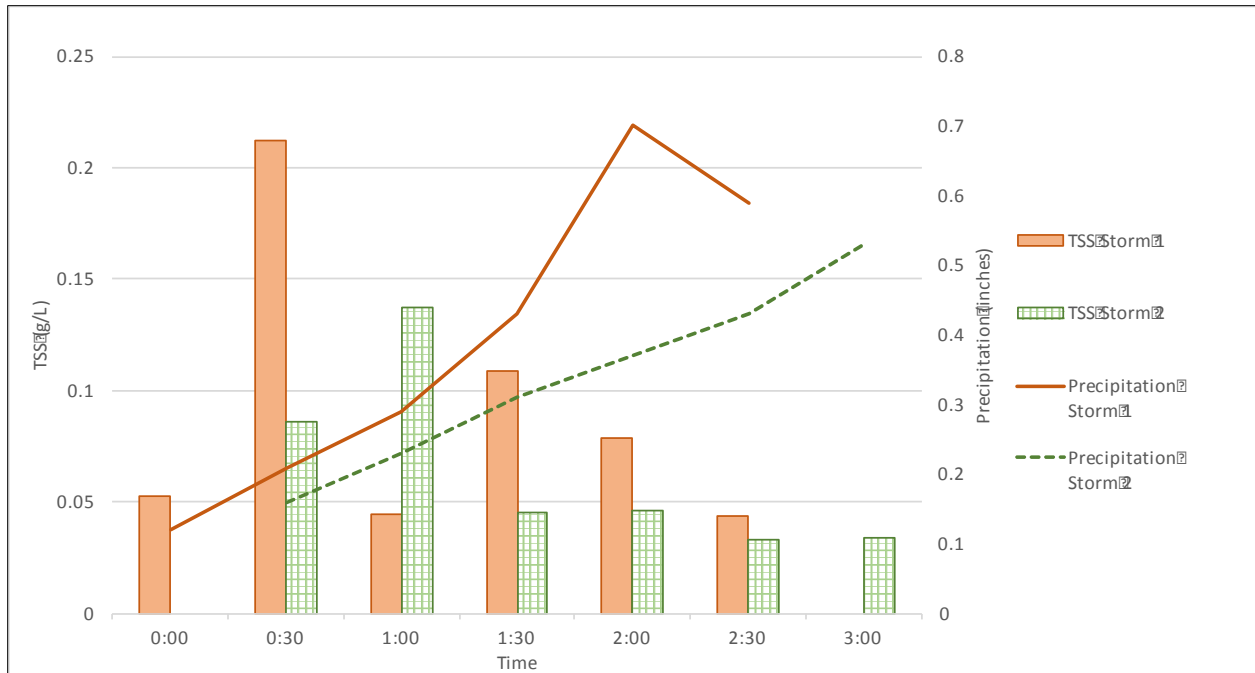

FIGURE 36: RUNOFF TESTED FOR TSS WITH CUMULATIVE RAINFALL FOR STORM 1 AND STORM 2

4.4.1.5 TSS and Specific Conductance in Runoff

Figure 37 shows Storm 1 TSS data along with specific conductance. Even though these levels are read on two separate axes they closely mirror each other; when TSS levels rose, specific conductance levels increased as well. This can also be seen in Figure 38, which represents Storm 2. Except for the drop at hour 1 in Figure 37 and the increase at hour 1 in Figure 38, the similarities of specific conductance and TSS were very close.

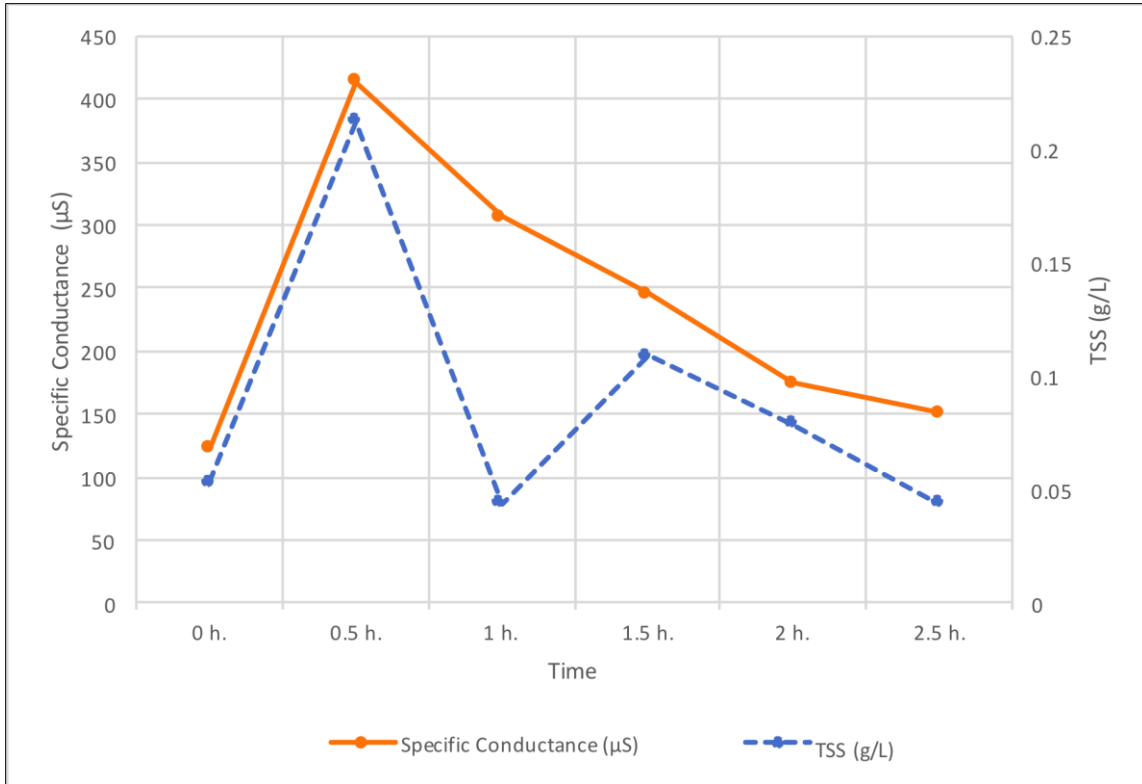

FIGURE 37: RUNOFF TESTED FOR SPECIFIC CONDUCTANCE VS. TSS STORM 1

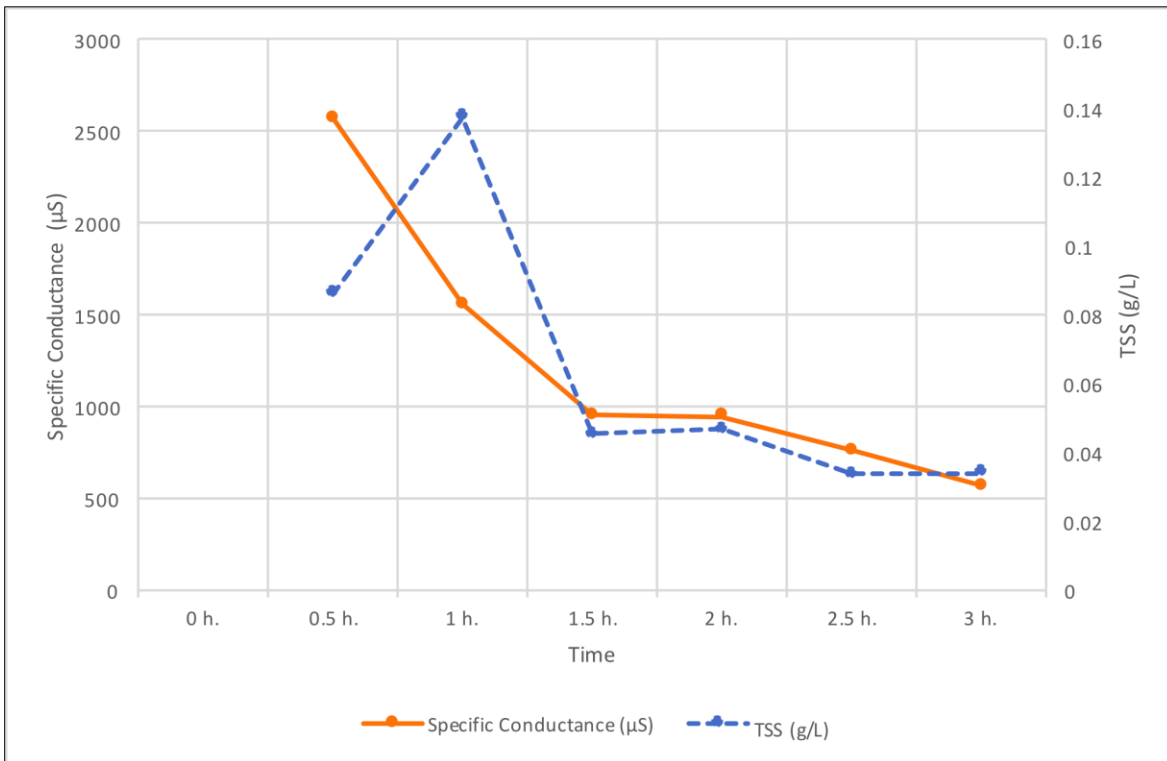

FIGURE 38: RUNOFF TESTED FOR SPECIFIC CONDUCTANCE VS. TSS STORM 2

4.4.2 Soil

The bottom of the basin per construction standard plans, Appendix B: Layout, is composed of crushed rocks and gravel with impervious soil in both chambers. Chamber 1's topsoil had dark organic soil that had washed into the basin due to storm runoff. Chamber 2 had a sloped sand side that ran parallel to it to increase infiltration when water levels were high. Over time a large percentage of the sand had washed down the slope into the bottom of Chamber 2, as seen in the Appendix G: Field Notes. When soil samples were taken, we noticed that the thickness of the dark topsoil decreased in depth the further away from the inlet, as documented in Table 11. The layer below the topsoil was lighter and more compact, most likely filled in during construction. Soil samples were collected according to the map shown in Figure 39.

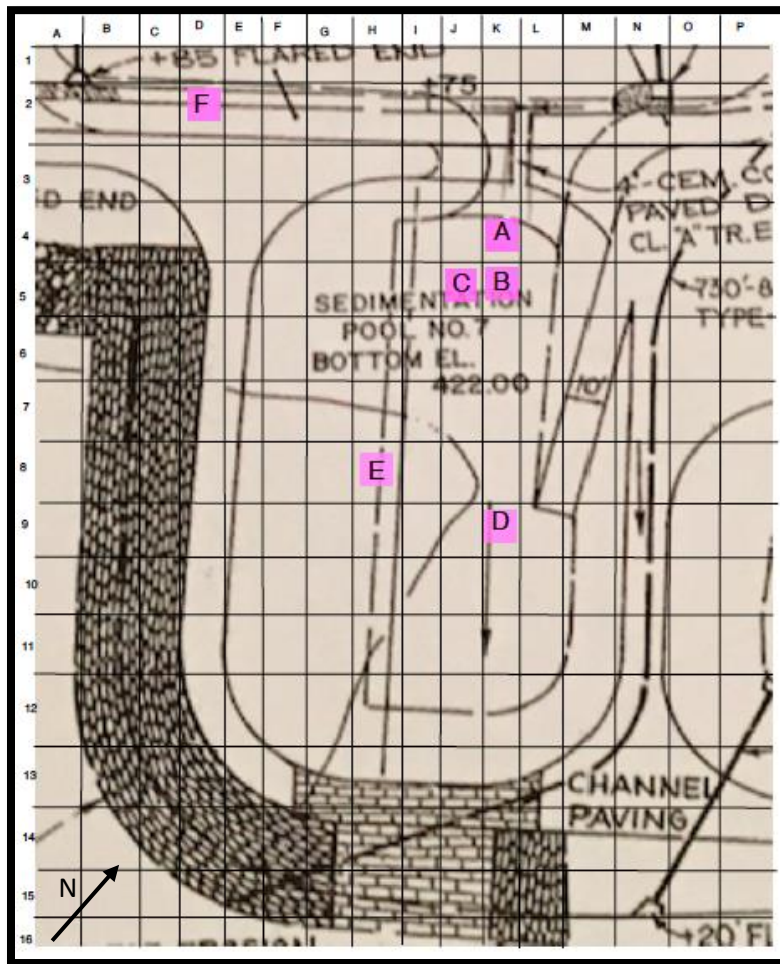

FIGURE 39: SOIL SAMPLE MAP

TABLE 11: SOIL SAMPLE LOCATION AND TYPE

Sample Location	Soil Type	Depth of Sample	Color
A	Topsoil	6"	Dark
B	Topsoil	11"	Dark
C	Fill	6"	Light
D	Mix of Both	1'-1'6"	Light & Dark Mix
E	Topsoil	4.5"	Dark
F (Control)	Topsoil	1'1.5"	Dark

Figure 40 shows the location of sampling vs. the metals that were analyzed with the highest levels. Fe was not included since it was found naturally occurring in soil and its levels would have skewed the rest of the data.

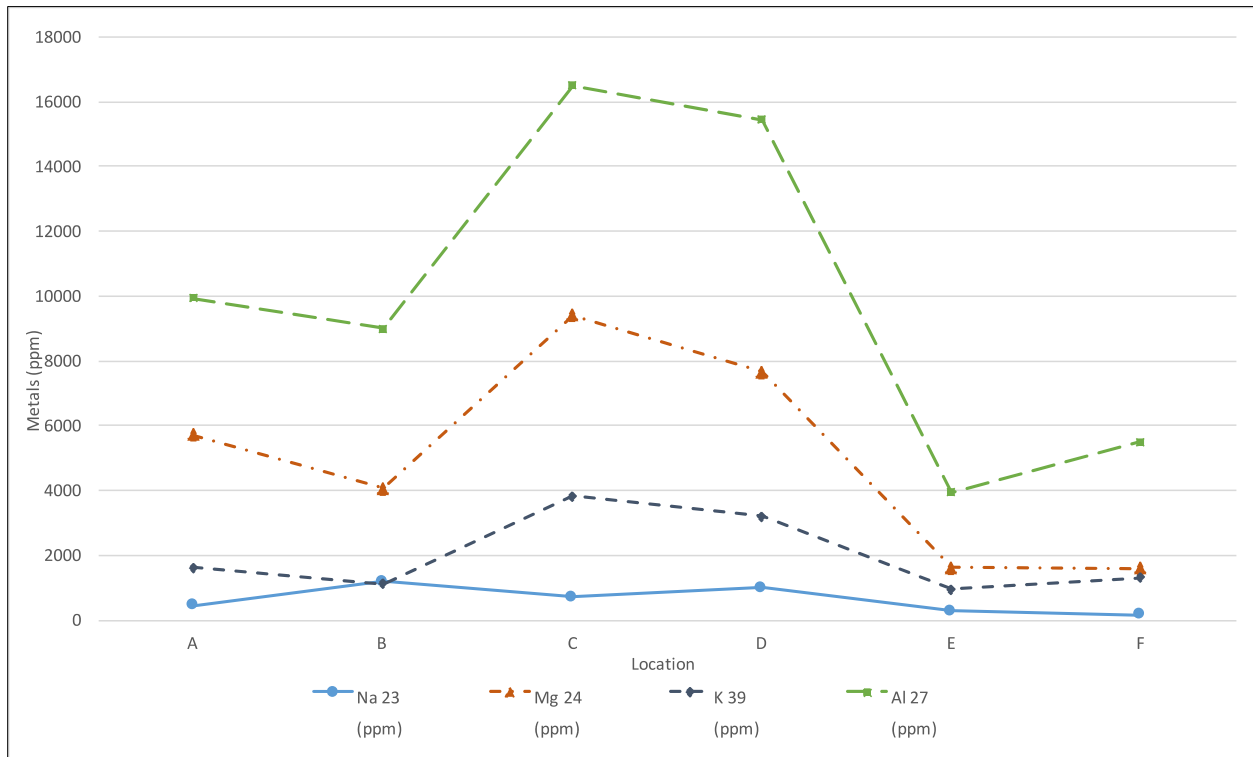

FIGURE 40: SOILS TESTED FOR TOTAL METALS

The most important aspect of Figure 40 was the levels of metals present in the soil. When analyzing this graph, we focused on the significance of the sample's soil type and collection location within the basin. On the sampling location map, B and C are close together, however, their results were largely different on the graph. Higher levels of Mg, K, and Al were found in sample C, which came from the layer of soil below the topsoil. This indicated that this type of soil

attracted those metals specifically. Na was also tested for but had very low levels. When taking a closer look, Na dipped at location C compared to the other types of metals. This means that the topsoil trapped the most Na while the deeper soil did not.

Figure 40, also shows that at location E, found in Chamber 2, the amount of metals captured in the soil was lower than levels found in Chamber 1. This is due to the fact that Chamber 2 had a high level of sand present, which quickly infiltrated the runoff. Additionally, most runoff did not reach Chamber 2.

4.4.3 Groundwater

Groundwater samples were collected according to the map shown in Figure 41. The groundwater table is unknown for this location because we were unable to dig deep enough to reach it. However, after rainstorms, the soil was saturated enough to take several samples.

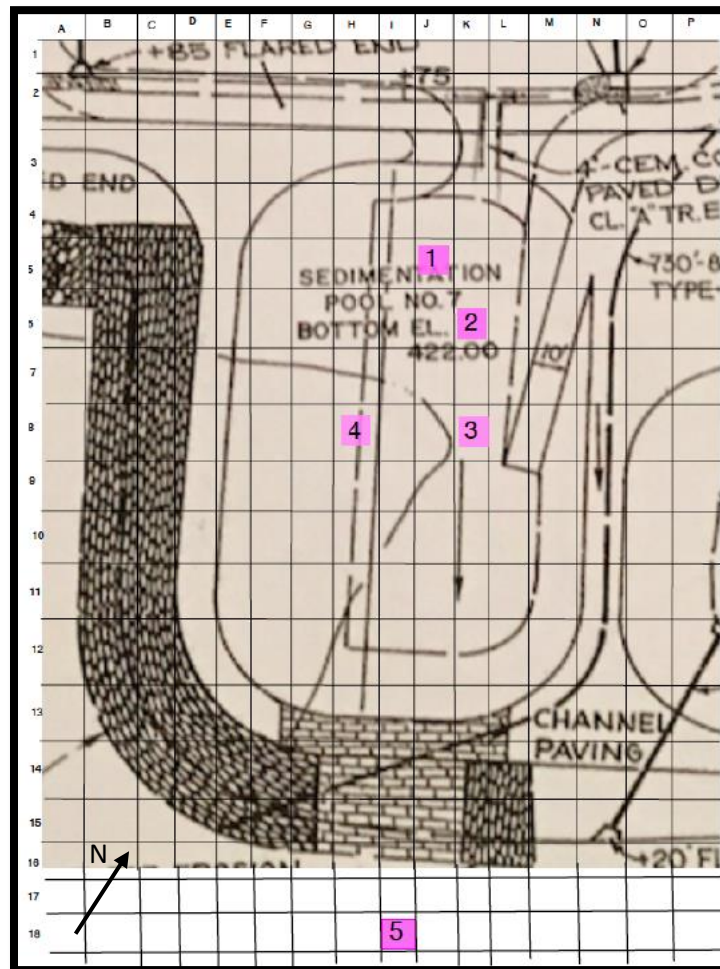

FIGURE 41: GROUNDWATER SAMPLE MAP

4.4.3.1 Sodium in Groundwater

The groundwater samples from both storms were tested for dissolved metals and compared to specific conductance in Figures 42 and 43.

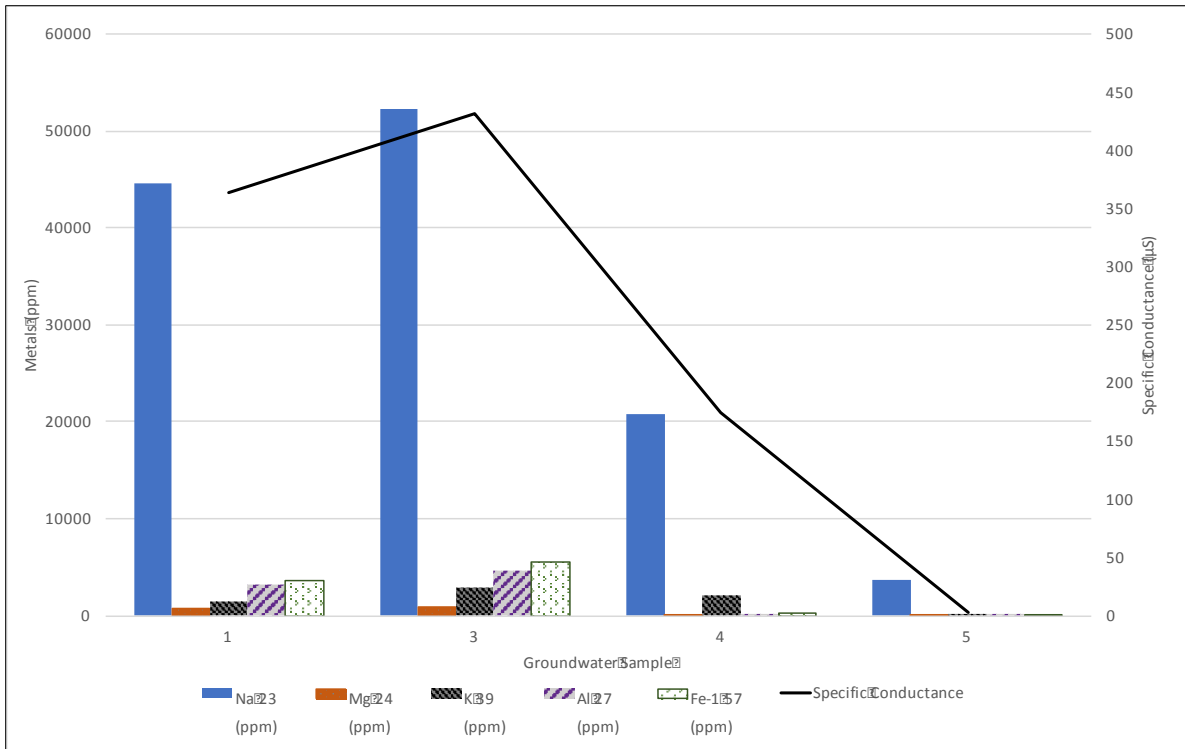

FIGURE 42: GROUNDWATER TESTED FOR DISSOLVED METALS STORM 1

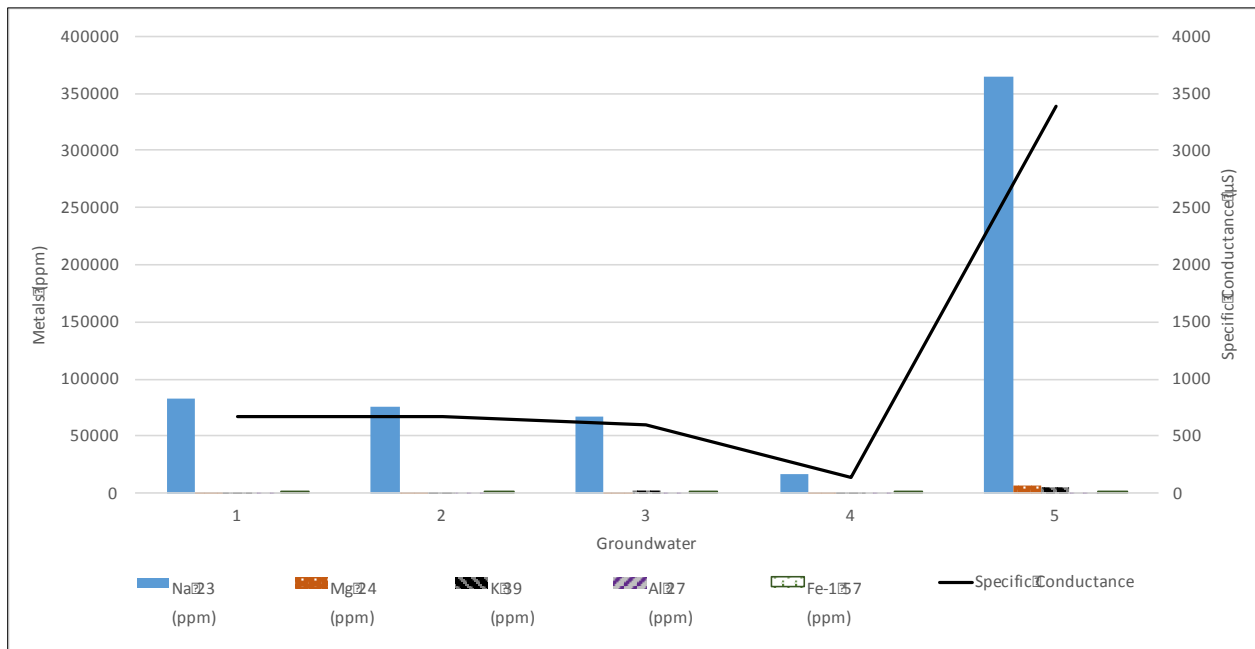

FIGURE 43: GROUNDWATER TESTED FOR DISSOLVED METALS STORM 2

Figures 42 and 43 reveal a decrease in Na concentrations in groundwater along the flow path through the basin. In Figure 43, at location 5 the Na levels were much greater than the other groundwater sample sites from Storm 2. There could be a couple of reasons for this significant increase of Na. One possibility could be an error in sampling or contamination from this specific site. There also could be reactions involving aqueous sodium and sodium sorbed by the sediments that influenced the measured concentration at this location. Another reason could have been that the groundwater collected was not actually flowing from the project basin but from another site. Two possible sources of flow are the clean water bypass that is northwest of location 5 and a culvert outflow collecting runoff from Greenland Road in the northeast direction of location 5. Our team made an educated guess as to where the groundwater from the basin flows; however, we do not have sufficient information to confirm our research at this time.

Both Figures 42 and 43 show that Na levels decreased from Chamber 1 to Chamber 2. Observing the scale of metals in ppm on both graphs shows that the groundwater from Storm 2 was much higher in Na, similarly to the runoff results. At that point in the winter season more road salt, pre-wet solution, and storm debris had accumulated, reflected on these graphs.

4.4.3.2 Magnesium in Groundwater

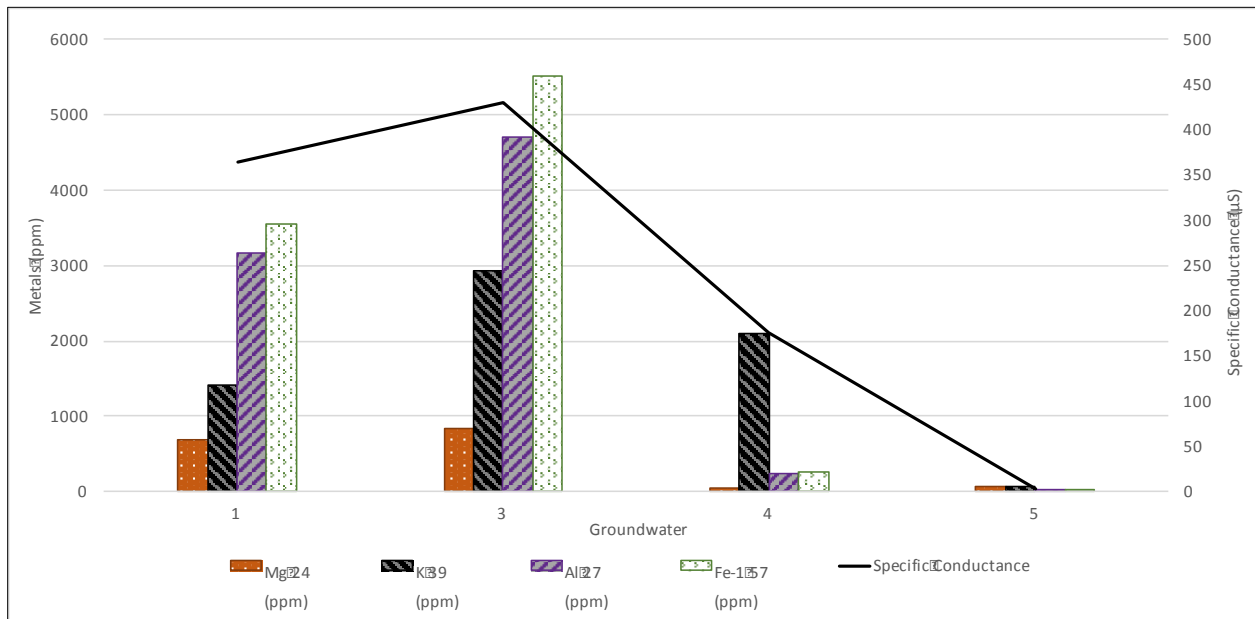

FIGURE 44: GROUNDWATER TESTED FOR DISSOLVED METALS STORM 1 W/O NA

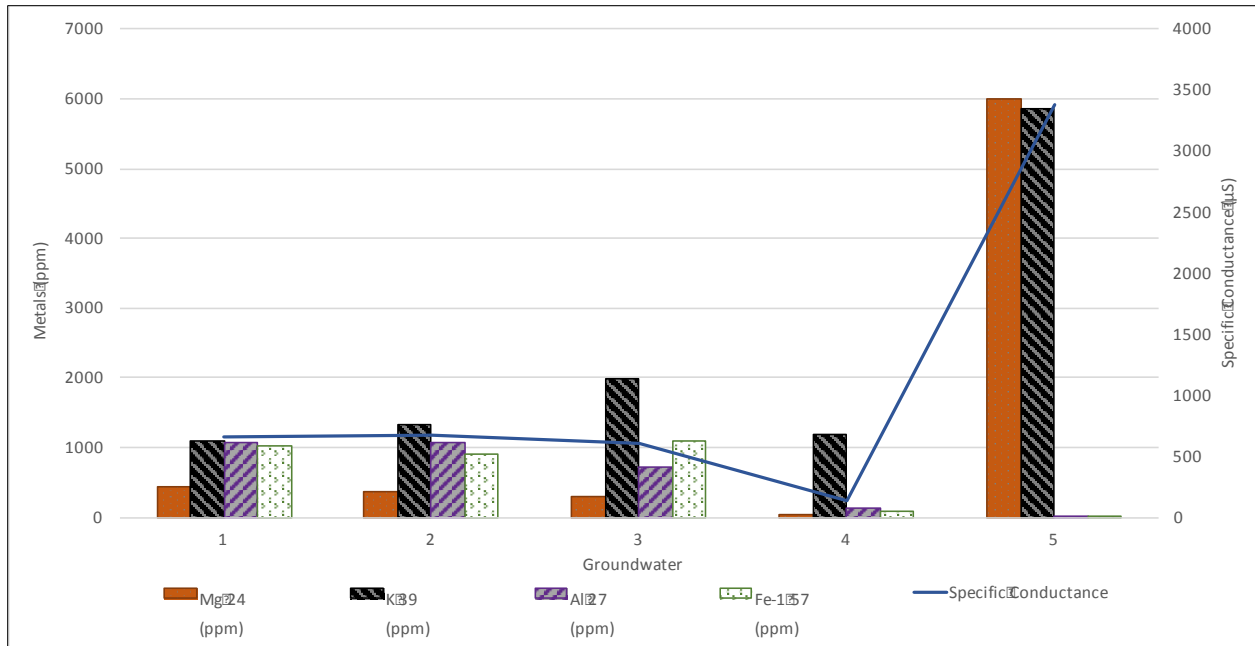

FIGURE 45: GROUNDWATER TESTED FOR DISSOLVED METALS STORM 2 W/O NA

As seen in Figures 44 and 45, Mg was efficiently trapped in the basin and by location 4 it was mostly removed during Storm 2. This revealed that the function of the project basin was effective in and trapping some of the metals.

Specific conductance levels are higher in Storm 2 than Storm 1 due to the higher levels of metals found in the basin. The specific conductance levels found in the reservoir, collected by the DCR, are between 60-240 µS throughout the year. However, the highest levels found in the basin were 431 µS for Storm 1 and 677 µS for Storm 2, significantly higher than what was found in the reservoir.

4.4.3.3 TSS in Groundwater

TSS was also tested for in groundwater as shown in Figure 46. Site 2 was not sampled during Storm 1, which is why there is no data shown. As seen in Figure 41, Locations 1, 2, and 3 were in Chamber 1 which explains their high levels of TSS due to direct runoff accumulation. Location 4, found in Chamber 2, was farther away from the inlet and did not have much runoff water infiltrating from standing water. Instead, we believe the groundwater samples were filtered water from Chamber 1 and by the time the groundwater reached this point the suspended solids had already been trapped. Location 5 had a higher level of TSS than location 4, which was interesting because in Figure 47 of the sample bottles the location 5 bottle was much clearer than location 4. That increase could be due to an error in the lab.

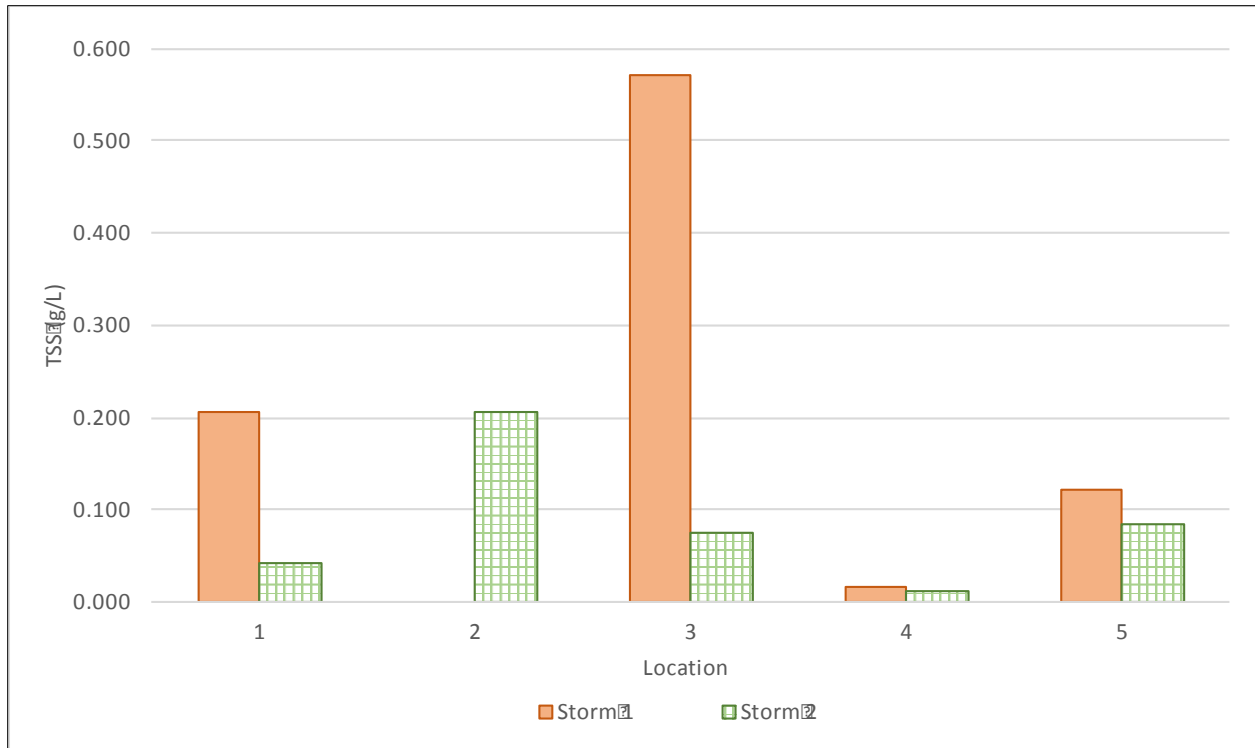

FIGURE 46: GROUNDWATER TESTED FOR TSS

Figure 47 shows the spectrum of groundwater samples collected after Storm 1. Note the visible differences in clarity in the samples labeled according to the sampling location number in red.

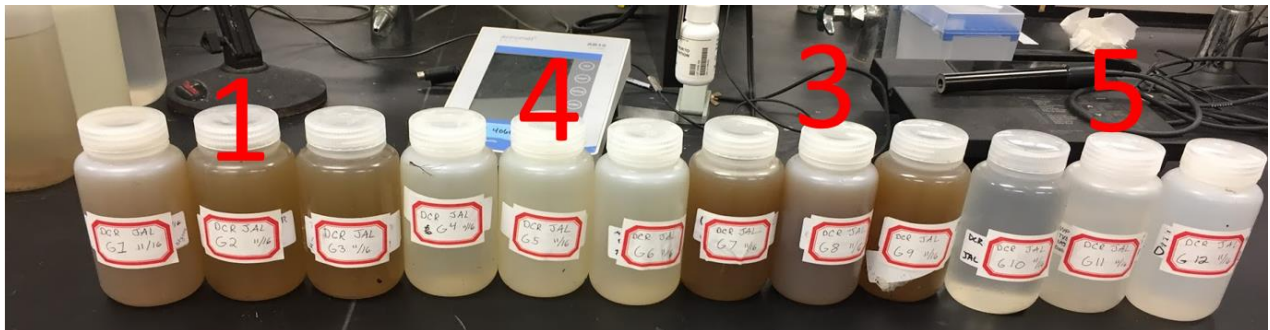

FIGURE 47: STORM 1 GROUNDWATER SAMPLES

4.4.4 Surface Water

Surface water samples were collected from the Stillwater River during dry and wet weather from Storm 2.

4.4.4.1 Sodium in Surface Water

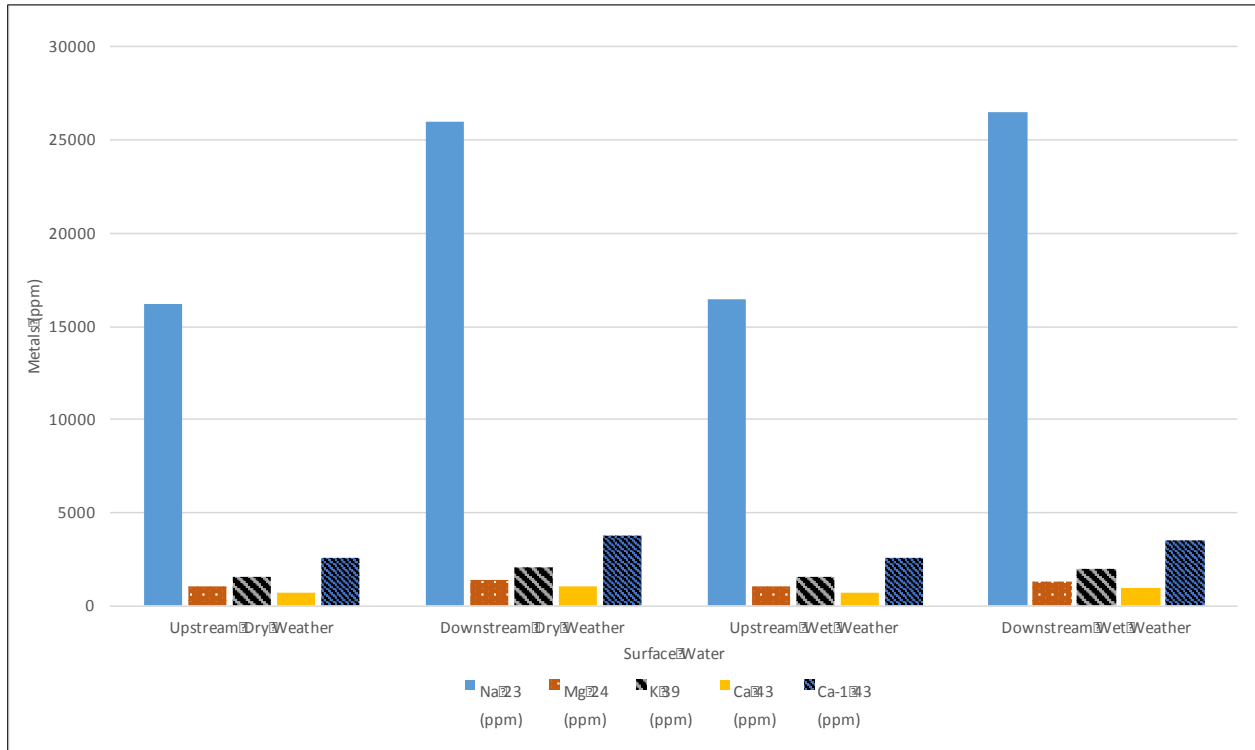

FIGURE 48: SURFACE WATER TESTED FOR DISSOLVED METALS UPSTREAM & DOWNSTREAM STORM 2

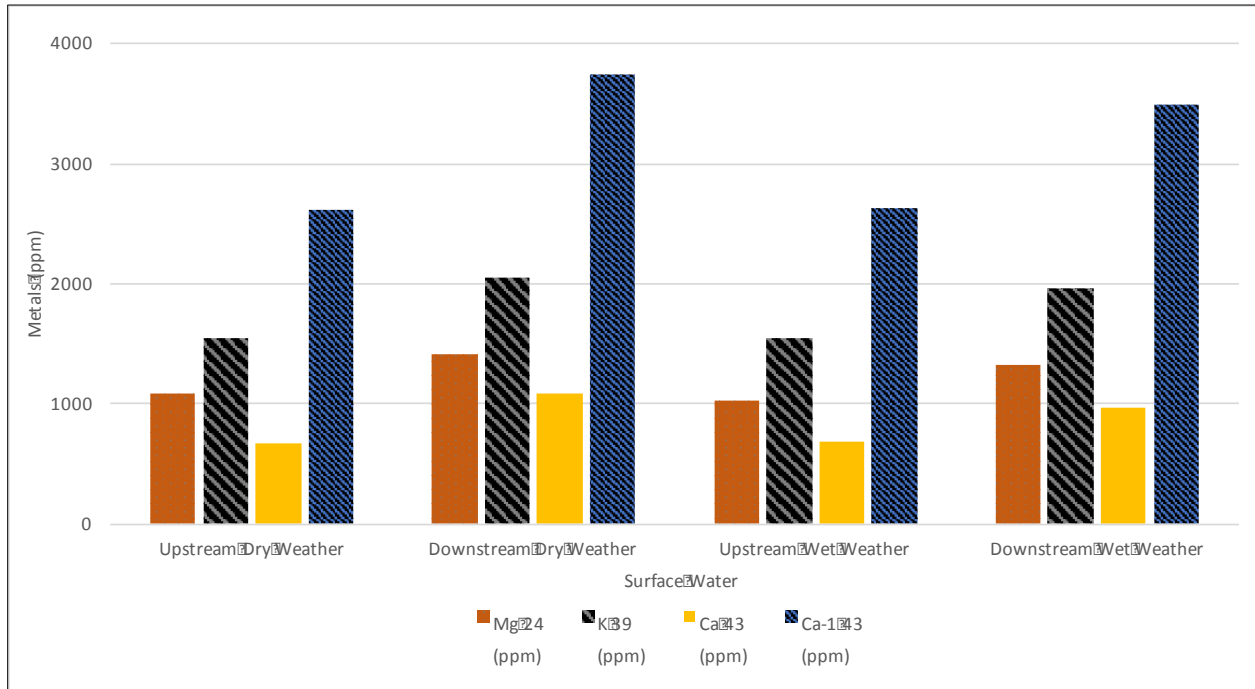

FIGURE 49: SURFACE WATER TESTED FOR DISSOLVED METALS UPSTREAM & DOWNSTREAM STORM 2 W/O NA

Figure 48 shows the Na levels in the Stillwater River upstream and downstream of the basin. The dry weather samples were taken two hours before the wet weather began. The levels of Na did not differ in between the two samples. One reason for the lack of level increase in Na may be due to the increased flow during the storm which would have diluted the concentration of Na present. Additionally, there are many sources flowing into the Stillwater River between the upstream and downstream sampling locations. Figure 49 shows the levels of other metals present such as Mg, K and Ca. The levels fluctuated ever so slightly between the dry and wet weather, for reasons most likely similar to Na.

4.4.4.2 Specific Conductance in Surface Water

Specific conductance is an important factor to consider when looking at water quality. Figure 50 shows the increase of specific conductance from upstream to downstream in the Stillwater River. The upstream samples were lower than the downstream samples by a difference of 100 micrograms. Additionally, we referred to the data from the USGS sample station, Appendix J: USGS Data, and there was an increase in specific conductance between the beginning of the storm and end of the storm.

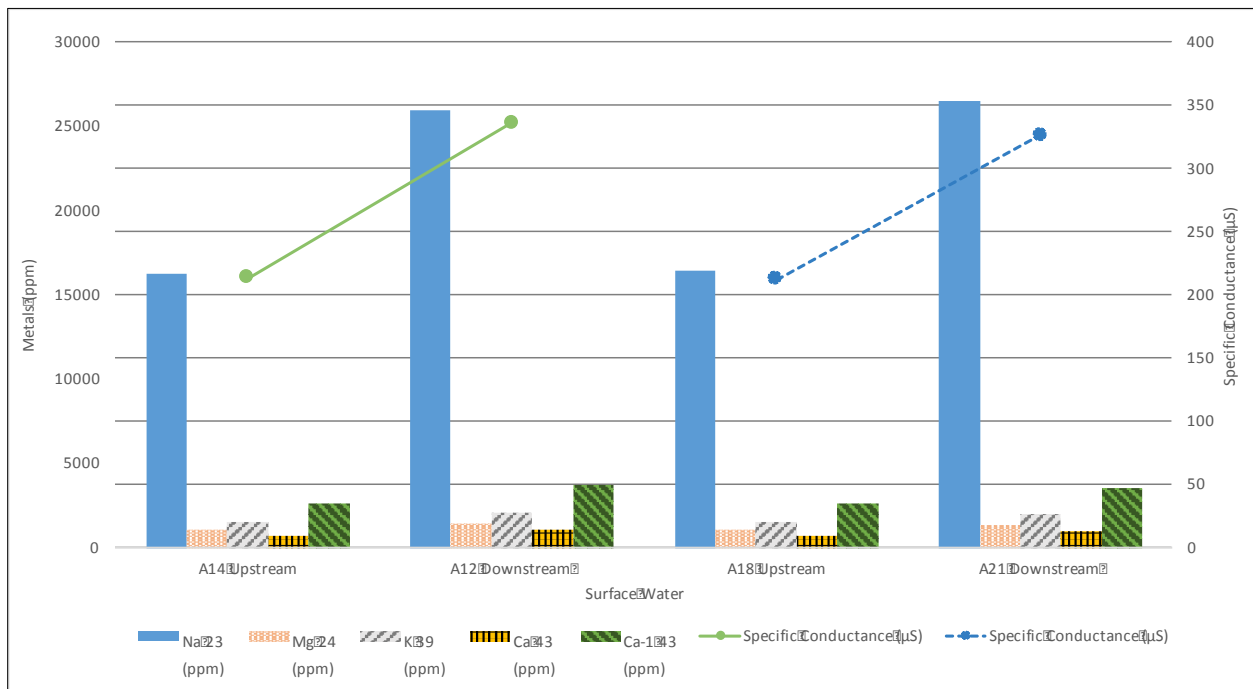

FIGURE 50: SURFACE WATER DOWNSTREAM VS. UPSTREAM TESTED FOR DISSOLVED METALS DURING STORM 2

Figure 50 additionally shows how there is a correlation between an increase in specific conductance and an increase in metal concentrations. Specific conductance levels found in the tributaries of the Wachusett Reservoir, collected by the DCR, were between 60-240 µS throughout the year. However, upstream concentrations in the Stillwater River were measured

at 213 μS and 212 μS while downstream concentrations were measured at 336 μS and 326 μS . Downstream levels are higher than upstream levels and levels recorded by the DCR for this area.

Overall, the data explained in Section 4.4 Stormwater and Basin Characteristics section has clarified how the basin functions. Analysis of the stormwater as it entered the basin to groundwater led to the conclusion that a majority of the metals tested for were captured by the soils. Na enters the basin in high amounts, especially after road salt is placed on the roads, and those amounts remain at high levels throughout the basin which can be seen in the groundwater concentrations. Downstream metal concentrations increased during dry and wet weather concluding that I-190 stormwater runoff could have a possible effect on the levels. Metals are not being completely trapped within the project basin which allows for improvements to be made to the stormwater treatment basin to increase efficiency.

Chapter 5: Recommendations / Design

This project includes a design for an optimal basin for the project location. For the purposes of this project, the method was to design a basin (i.e. the optimal basin) that reflects the current approaches and requirements, which can be compared with the characteristics of current project basin. The design focused on addressing points of concern highlighted in the Chapter 4 Results, finding the most effective way to trap contaminants, complying with the Massachusetts Stormwater Management Standards, and overall improving water quality. Once we selected an infiltration basin for the optimal basin design, each aspect of the basin (including the sediment forebay, check dam, liner, soil, plants, outlet, groundwater testing well, trash rack, and fencing details) were selected. The basin was then evaluated to ensure it met standards 1-10 of the Massachusetts Stormwater Management Standards. In addition, alternative recommendations were made to the DCR that aimed to improve the current project basin to maximize the basin's potential for the region it supports.

5.1 Optimal Basin Design

Our layout design for the optimal basin can be seen in Figure 51. The runoff will be transported from I-190 in a fashion similar to the current project basin. It will be directed by the concrete ditch to enter into the basin inlet. The runoff would then continue through a trash rack as it approaches the sediment forebay. Runoff in the sediment forebay would pool until it spills over the check dam. The check dam would then direct the flow of the runoff into the infiltration basin. Located within this infiltration basin would be two groundwater testing wells, native vegetation and a liner underneath the soil layer, made up of organic matter and clay. The runoff would continue to settle and infiltrate in the basin until it reaches the groundwater. It would exit either through the groundwater or through the spillway outlet. Additionally, there would be no fences surrounding the basin per 2017 Draft MassDOT Handbook guidelines.

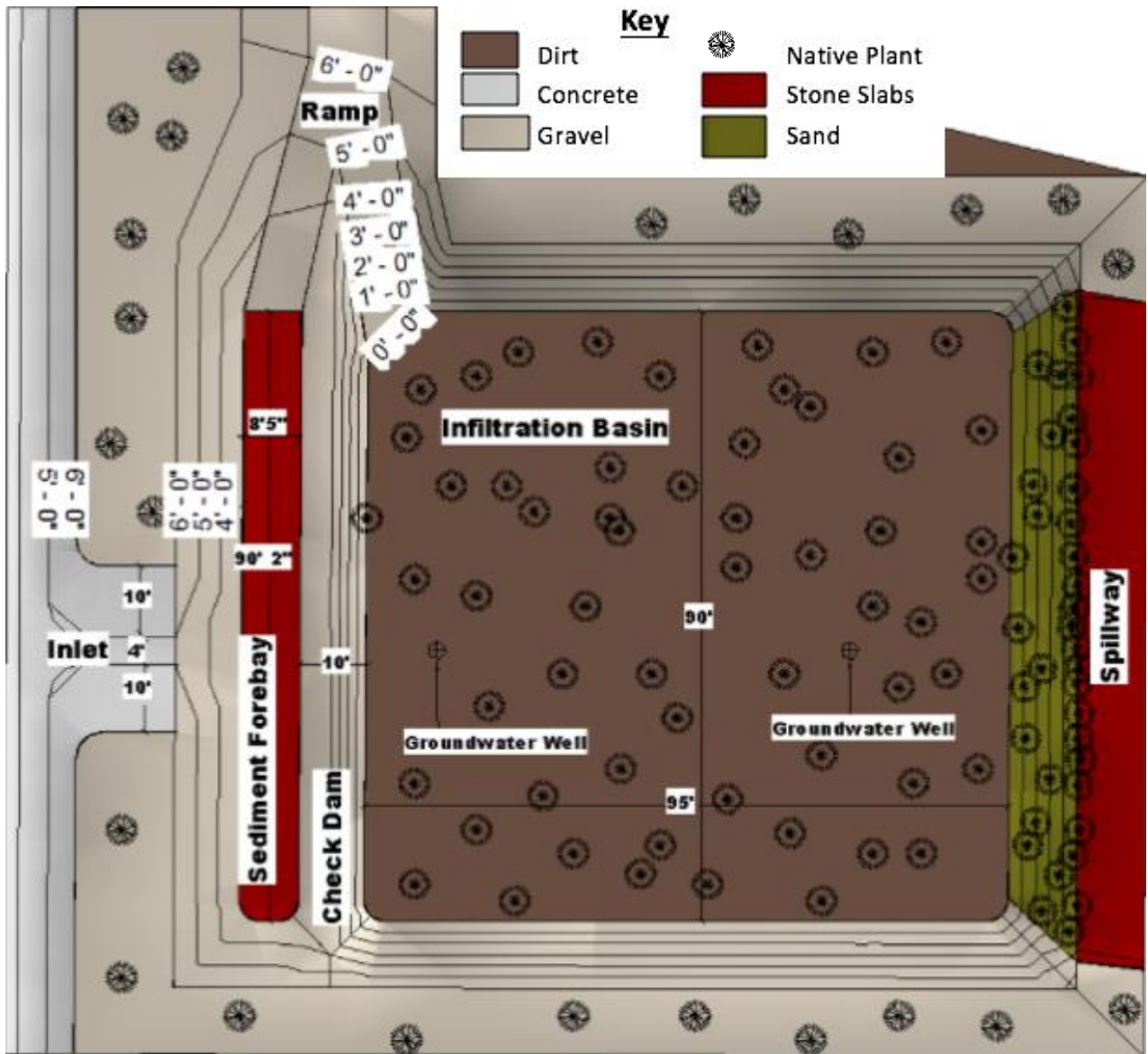

FIGURE 51: OPTIMAL BASIN LAYOUT

The final dimensions for the optimal basin would be 90' W x 95' L x 6' H or 51,300 ft³ for the infiltration basin and 90'2" W x 8'5" L x 3' H or 2,277 ft³ for the sediment forebay. The size increase is just one of the several differences, Table 12 shows a few of the similarities and differences.

TABLE 12: SIMILARITIES AND DIFFERENCES BETWEEN PRESENT AND OPTIMAL BASIN

Similarities	Differences
Similar inlet structure	Optimal basin is larger to be able to handle a 100-year storm
Ramp used to access basin for maintenance	Basin materials differ to trap more metals
Outlet spillway	Permanent groundwater testing wells
Vegetation present	Native vegetation planted
Sand present for rapid infiltration	Basin conforms to Draft 2017 MassDOT Handbook
	Trash rack added to inlet of basin
	Removal of fences
	Liner in basin to trap contaminants
	Impervious Sediment Forebay

In addition to the increased size of the optimal basin, the materials in the basin are used to improve efficiency of the basin. Figure 52 displays a side view section which allows for the layers of the basin to be seen. The materials shown in the Figure 52 will be discussed in further detail to explain why these materials were chosen and how those materials would positively affect water quality.

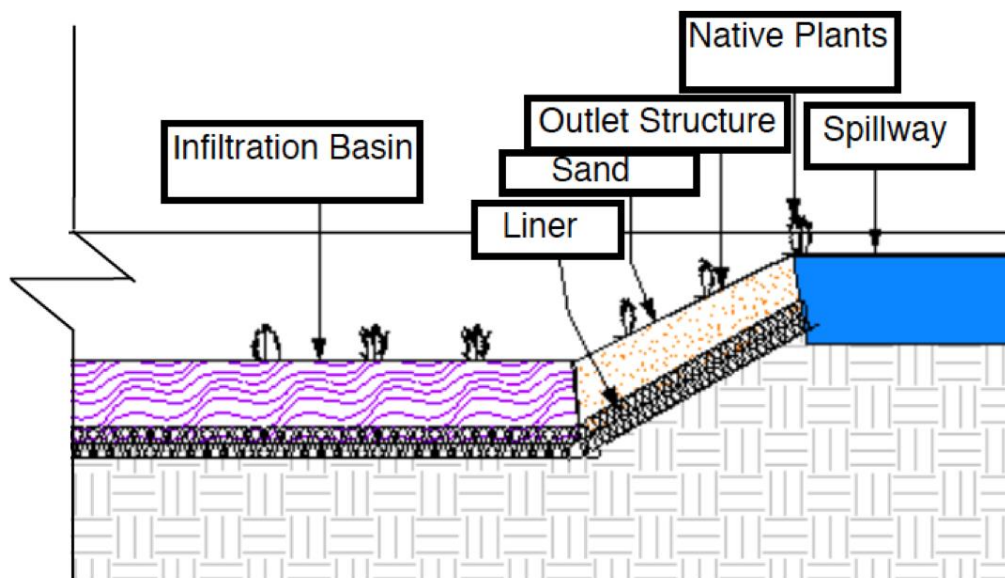
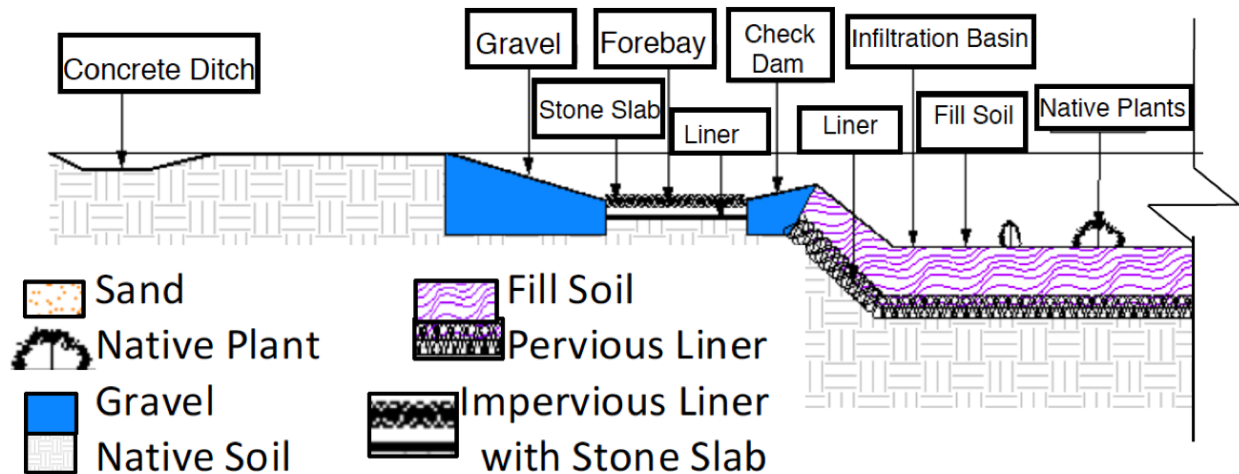

FIGURE 52: OPTIMAL BASIN SECTION

5.1.1 Size

To determine the size of the basin the Simple Dynamic Method was used (MassDEP Handbook, 2008). The Simple Dynamic Method, Equations 4 and 5, was chosen because it takes into account stormwater that exfiltrates at the same time as the chamber is filling up, unlike the Static Method which assumes no exfiltration until the basin holds the required recharge volume. Additionally, the Dynamic Field Method was not chosen because it required more soil testing in the field. The recharge volume (Rv), calculated in Section 5.2.3 Standard 3: Recharge Volume, was 13,426ft³. This value was used to determine the minimum required surface area for the bottom of the basin. The depth of the infiltration basin (D) was assumed to be 6 feet, which is one foot more than the existing project basin's depth because it allows for a smaller area of land to be used while still being an appropriate depth to access the basin for maintenance and testing. The saturated hydraulic conductivity (K) was determined using the 1982 Rawls Rates value from Table 2.3.3 in

the MassDEP Handbook, also shown here in Table 13. The value for loamy sand was used as it is found in the area around the basin. The allowable drawdown during peak of storm (T) was assumed to be 2 hrs. per the Simple Dynamic Method.

$$A = \frac{Rv}{D + KT}$$

EQUATION 4

$$A = \frac{13,426 \text{ ft}^3}{6 \text{ ft} + 2.41 \frac{\text{in}}{\text{hr}} * 2 \text{ hrs}} = 2,097 \text{ ft}^2$$

$$V = A \times D$$

EQUATION 5

$$V = 2097 \text{ ft}^2 * 6 = 12,583 \text{ ft}^3$$

Rv = Required Recharge Volume

A = minimum required surface area for bottom of basin

D = Depth of the infiltration basin

K = Saturated hydraulic Conductivity

T = Allowable drawdown during peak of storm

V = Storage Volume

TABLE 13: 1982 RAWLS RATES

Texture Class	NRCS Hydrologic Soil Group	Infiltration Rate (K) (Inches/Hour)
Sand	A	8.27
Loamy Sand	A	2.41
Sandy Loam	B	1.02
Loam	B	0.52
Silt Loam	C	0.27
Sandy Clay Loam	C	0.17
Clay Loam	D	0.09
Silty Clay Loam	D	0.06
Sandy Clay	D	0.05
Silty Clay	D	0.04
Clay	D	0.02

The required storage volume was determined to be 12,583ft³. Once the storage volume was calculated HydroCAD© was used to verify that the basin provided adequate storage according to the parameters in the simple dynamic method. A type III – 24 hour storm was selected but a start time of 11 hours and an end time of 13 hours was used to model it occurring in just 2 hours, per Volume 3 Chapter 1 of the 2008 MassDEP Handbook. This was used to determine the precipitation depth required to generate the needed recharge volume. The resulting hydrograph was then used to choose the appropriate dimensions of the basin to hold up to a 100 year storm. The final optimal basin size was determined to be 90 W x 95 L x 6 H or 51,300 ft³. The HydroCAD© summary report for the optimal basin can be found in Appendix F:1 Cipolletti Weir Hand Calculations. Figure 53 demonstrates that the optimal basin has adequate storage for all year storm events.

Optimal Basin *Type III 24-hr 100-Year Rainfall=6.50"*
 Prepared by HydroCAD SAMPLER 1-800-927-7246 www.hydrocad.net Printed 2/20/2017
 HydroCAD© 10.00-19 Sampler s/n S19929 © 2016 HydroCAD Software Solutions LLC

This report was prepared with the free HydroCAD SAMPLER, which is licensed for evaluation and educational use ONLY. For actual design or modeling applications you MUST use a full version of HydroCAD which may be purchased at www.hydrocad.net. Full programs also include complete technical support, training materials, and additional features which are essential for actual design work.

Events for Pond 1P: Basin

Event	Inflow (cfs)	Outflow (cfs)	Discarded (cfs)	Primary (cfs)	Elevation (feet)	Storage (cubic-feet)
1-Year	9.60	1.25	1.25	0.00	422.22	19,475
2-Year	11.60	1.31	1.31	0.00	422.86	25,234
5-Year	15.57	1.44	1.44	0.00	424.23	37,832
10-Year	17.55	1.51	1.51	0.00	424.94	44,554
25-Year	20.71	2.13	1.62	0.51	426.02	54,905
50-Year	23.08	6.95	1.63	5.33	426.11	55,813
100-Year	25.44	13.30	1.63	11.67	426.20	56,608

FIGURE 53: OPTIMAL BASIN EVENTS

5.1.2 Sediment Forebay

The sediment forebay is the first method of treatment for the runoff when it enters the basin. Water flows into the forebay chamber and pools until the water rises high enough to spill out of the forebay chamber over the check dam into the infiltration basin. The forebay’s main purpose is to slow the runoff flow from the inlet and allow for coarse sedimentation removal. By trapping the sediments in one location it would improve the ability to maintain the basin efficiently. MassDEP requires sediment forebays as a pretreatment step to infiltration basins (MassDOT Handbook). The sides are made of gravel to decrease erosion as water moves through. The bottom is an impervious stone slab to allow for easy cleaning and removal of sediments and trash. Additionally, a ramp for routine maintenance and emergency cleanup allows for access to this treatment area. According to the MassDEP Handbook sediment forebays must hold 0.1 inches per impervious acre. Since we have 6.2 acres of impervious area the sediment forebay must be

at least 2,250 ft³. By having the sediment forebay be the first step of treatment it allows maintenance crews the ability to quickly and efficiently clean up potential road spills from I-190 before contaminating the entire basin and eventually the Wachusett Reservoir.

5.1.2.1 Potential Spill on Highway

One crucial function of the project basin is to be able to support a potential spill from the interstate and be able to trap the spill until cleanup is able to occur. This influences the size of the sediment forebay, being that it is the first point of treatment which must capture the spill. Having a BMP that is able to do this is essential because it could be very detrimental if the contaminants reached the drinking water source. Procedures to accomplish the cleanup would be according to the Massachusetts Contingency Plan and the groundwater levels of the site would have to meet Massachusetts Drinking Water Standards. Additionally by having the groundwater testing wells in the basin, samples could be collected after the cleanup to determine if site was completely clean. Through discussion with the DCR and according to an assessment made in 2008, the design spill amount is 150 gallons carried by a commercial vehicle. This is a spillage size the sediment forebay can support.

5.1.3 Check Dam

A check dam is used within a stormwater BMP to separate the sediment forebay from the infiltration basin. It is typically made up of stone or earth and built on hardened ground to reduce erosion. It is used to control the flow path and the velocity of runoff that goes through the BMP. An impermeable check dam is best suited for this location because it would retain runoff by creating a pool of water that would accumulate until spillage over the top occurs due to excess water. This process further delays the infiltration time to allow for a greater settling time of sediments before reaching the infiltration basin (MassDOT Handbook, 2017).

5.1.4 Liner

A permeable liner is often used in stormwater BMPs as a treatment aspect of the infiltration basin. The 2017 Draft MassDOT Handbook suggests the usage of a liner as a preventive measure to reduce the transport of contaminants into and through groundwater. It is used to treat the stormwater after it has gone through some portion of soil before it enters the groundwater.

The liner would be placed on the entire bottom of the infiltration basin. Necessary requirements are to assist with erosion control, trap soil particles, and be easily maintained. This would ensure that runoff that does flow through the liner has gone through the treatment of trapping soil particles and the MassDOT can easily repair and monitor how the liner is working. The suggested material for this is geotextile material or earthen material (MassDOT Handbook, 2017).

Through research of various MassDOT documents and companies in the liner industry, nonwoven geotextile liners seem like the best suited option. They filter soil particles, therefore the water

that flows through is clearer. They are made from polypropylene fibers and formed into a fiber network, creating a durable stable structure. This assists with erosion control and improving the life cycle of the basin (Nilex All Products, 2017). While this is the best liner option, overtime clogging could occur and require maintenance. When clogging occurs it will be evident by pooling of water and the liner will need to be replaced.

Woven geotextiles were researched but they are mainly used for construction and help provide support to roads improving life cycle and providing reinforcement. Geosynthetic clay liners were also researched but through its chemical components a seal is created, greatly reducing the passage of water through it. This does not support abundant groundwater recharge (Nilex All Products, 2017).

A geoenvironmental engineer would be required to assist with the development and implementation of this liner in the infiltration basin and would be able to provide insight on exact size and placement.

5.1.5 Soil

Before construction, it is necessary to complete a soil survey. In order to determine the size of the optimal basin the infiltration rate was needed to appropriately account for groundwater recharge. The soil type of the area determines the saturated hydraulic conductivity rate of water through the soil. According to the National Resources Conservation Council (NRCS) Soil Survey the project basin is split into two types of soil. The project basin itself is made up of Sudbury fine sandy loam and the access road to the basin and the soil next to the route road is Hinckley loamy sand. Sudbury fine sandy loam is a moderately drained soil that has moderately rapid permeability with a higher acidity level. Hinckley loam sand is deep and very well drained soil with rapid permeability and high acidity levels. The majority of the land surrounding the project basin is also made up Hinckley loam sand (Soil Survey of Norfolk and Suffolk Counties, Massachusetts, 1989).

During construction of the optimal basin the current soil in place would all be removed and new uncontaminated soil would be brought to the site. This is partially due to our results that showed how the filled soil was capturing less metals than the topsoil, evidence that the filled soil is not currently working well. To slow the process of infiltration from surface water into groundwater is it necessary to have soil that has a moderately slow infiltration rate. Clay soil has smaller pores so that it takes water longer to get through. Therefore, a good soil type for this area would be partially made up of clay. The addition of organic matter increases pore space slightly therefore a correct combination of the two can allow for proper rates of infiltration and function (Soil Quality Indicators). This combination of the two types of soil also promotes Cation Exchange Capability (CEC) which is the ability for soil to hold exchangeable cations. A higher CEC is found in soil that has a higher clay and higher organic matter content. The soil has these negative sites that interact with the cations from the contaminants in the stormwater. This in return supplies

the vegetation in the basin with nutrients to grow. Some steps to maintain the soil is making sure the pH level is above 5 and the net Ca and K in the soil is adequate for plant growth. This creates the soil's buffering capacity. A higher CEC in soil does require less maintenance but liming may need to be performed occasionally to maintain the pH. By performing this maintenance it would help maintain the current levels and context of the soil so that the higher level of CEC would remain (Brown, 2017).

Since the soil is part of the infiltration basin and comes after the sediment forebay, the hope is that flow velocity would be reduced and easier to control. Through advice given under a Civil/Soil Engineer, drainage, maintenance, and erosion concerns can be met.

5.1.6 Plants

Plants were specifically selected to be placed in and around the basin. Certain criteria was looked at when choosing plants such as the cost, maintenance, if they are native to the area, and if they are drought resistant. We also wanted a plant that would not be too tall or disrupt the structure of the basin. The New England Wetland Plants, Inc. (NEWP) was the main resource when researching. Table 14 visualizes how we selected which plants to use for the basin.

TABLE 14: PLANT MATRIX

Characteristic	Native to New England	Erosion Control	Low Maintenance	Low Height (>2')	Soil Tolerance	Drought Resistant	Flood Resistant
Virginia Wild Rye	X		X				X
American Beach Grass	X	X	X	X	X	X	
Blue Flag Iris	X	X	X	X	X		X
Blue Vervain	X	X	X	X			X
Green Bulrush	X	X	X	X		X	X
Boneset	X	X					X
Soft Rush	X	X		X	X		X
Switch Grass	X	X	X			X	
Woolgrass	X	X			X	X	X
Tall Salt Marsh Cordgrass	X				X		X

The plants we have deemed best for the basin that had at least 5 of the 7 characteristics are:

- American Beach Grass
- Blue Flag Iris
- Blue Vervain
- Green Bulrush
- Soft Rush

These plants are well equipped to handle erosion control, detention sites, and different types of soils. Although other types of plants would probably grow in the basin we would rather choose plants that we know would not affect the structure of the basin. We also wanted plants that would be able to withstand periods of droughts and periods of flooding. The present basin's sandy slope has not withstood time very well. We hope by adding a bit of American Beach Grass we can stabilize the sandy soil. The Blue Vervain is eaten by rabbits and other small animals which provides low maintenance control. All plants listed come in a set sold by NEWP, the plants above cost \$1.05 - \$1.40 per plant.

5.1.7 Outlet

The optimal basin outlet would replicate the current outlet used in the project basin because it is stable and effective at this site and the most cost effective option. The current design of the outlet, a spillway outlet, has a lower elevation compared to the top of the basin which directs the water out of the basin. It is lined with stone to decrease erosion of soil. Additionally, the spillway is lined with gravel and crushed stone to slow water flow and decrease erosion as it moves out of the basin.

According to the MassDOT Handbook, Multi-Stage Outlet Control Structures are becoming the new focus for outlets but will not be used at this location. This type of structure replicates a pipe and is preferred in areas where outlet zones are neighboring residential areas which is not applicable to our site. There are no residents directly downstream of the project basin that would be effected by outflow or flooding. One benefit of using pipes is that the outlet location of water is known compared to the current spillway where there is no guarantee to where water would flow.

5.1.8 Groundwater Testing Well

The installation of a groundwater testing well would allow the DCR to routinely be able to take groundwater samples in the basin. The well would have a depth greater than that of the liner. Using a land survey design plan provided by the DCR, the groundwater testing well would be similar to an inspection port as seen in Figure 54. In this design a "4" perforated PVC with screw cap wrap pipe with permeable geotextile fabric" (Sewage Disposal System, 2015) was used. The main requirement for installing this well is using machinery that is able to dig a hole deep enough

for the well. This groundwater testing well would also be used if a spill was captured in the basin to make sure the contaminants were removed.

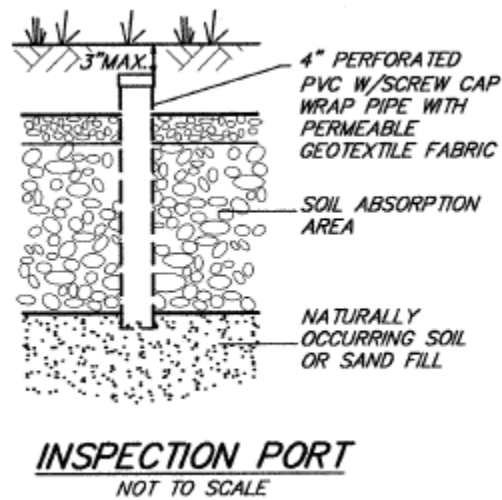

FIGURE 54: GROUNDWATER TESTING WELL (SEWAGE DISPOSAL SYSTEM, 2015)

5.1.9 Trash Rack

The accumulation of trash affects the flow of runoff through the basin and contributes to sediment buildup. One additional feature that could be added to the optimal basin to reduce this is a trash collection rack/cage. The rack would be attached to the concrete inlet on the slope and extend over part of the sediment forebay. This rack would allow for routine pickup of the trash that has collected on top and underneath the rack, preventing it from collecting in the basin like it currently does. Additionally, the rack would be made from steel, therefore able to sustain various weather conditions.



FIGURE 55: TRASH COLLECTION RACK DESIGN OPTION (MISC. METALS, 2012)

Figure 55 shows an example of a rack similar to what would be used in the optimal basin. The only difference is that the trash could be removed from both the top of the rack as well as from the sides.

5.1.10 Removal of Fences

In the 2017 Draft of the MassDOT Handbook the MassDOT calls for removal of all fences at BMP sites to improve access into the BMP in case of emergency. This was also reiterated through conversations with MassDOT employees. Therefore this would just eliminate the construction of this feature from the design.

5.2 Stormwater Management Standards

The Stormwater Management Standards were put in place as part of the Stormwater Policy issued by the Massachusetts Department of Environmental Protection in 1996. The Stormwater Management Standards were revised in 2008 with the Massachusetts Department of Environmental Protection's Stormwater Handbook (MassDEP Handbook) and adopted into the Wetlands Regulations and Water Quality Certification Regulations (MassDEP, 2008). Our optimal BMP is designed in compliance with the revised 2008 Stormwater Management Standards. The Massachusetts Department of Transportation provides the MassDOT Stormwater Management Design Handbook (MassDOT Handbook) as an additional resource to the MassDEP Handbook to assist designers in applying these standards. The MassDOT Handbook was available only in draft stages at the time of the MQP. Compliance with this 2017 Draft version of the MassDOT Handbook is described in detail in the following sections.

5.2.1 Standard 1: Erosion

Standard 1 ensures "no new stormwater conveyances (e.g. outfalls) may discharge untreated stormwater directly to or cause erosion in wetlands or waters of the Commonwealth." Our optimal basin main discharge is infiltration but in the case that excess water needs to exit the basin it would do so over the outfall berm which is lined with stone to prevent erosion.

5.2.2 Standard 2: Peak Discharge

Standard 2 requires that "stormwater management systems shall be designed so that post-development peak discharge rates do not exceed pre-development peak discharge rates." The optimal basin meets this standard because it can hold a 100 year storm.

5.2.3 Standard 3: Recharge Volume

Standard 3 expects that "loss of annual recharge to groundwater shall be eliminated or minimized through the use of infiltration measures including environmentally sensitive site design, low impact development techniques, stormwater best management practices, and good operation and maintenance." Equation 6, from the MassDEP Handbook was used to calculate the required

recharge volume. The target depth factor was determined using Table 2.3.2 from the MassDEP Handbook also shown here in Table 15. From the table a weighted average was calculated using Soil Type A, B and C to get a target depth factor of 0.59 inches due to 96% of the soil being Type A. All land in the drainage area with a CN of 98 was considered to be the impervious area, equaling 6.2 acres as seen in Figure 56.

$$Rv = F \times I$$

EQUATION 6

$$13,426 \text{ ft}^3 = 0.59 \text{ in} \times 6.2 \text{ acres}$$

Rv = Required Recharge Volume

F = Target Depth Factor

I = Impervious Area (pavement and rooftop area on site)

TABLE 15: RECHARGE TARGET DEPTH BY HYDROLOGIC SOIL GROUP (HANDBOOK, 2008)

NRCS Hydrologic Soil Type	Approx. Soil Texture	Target Depth Factor (F) (Inches)
A	Sand	0.6
B	Loam	0.35
C	Silty Loam	0.25
D	Clay	0.1



FIGURE 56: IMPERVIOUS AREA

5.2.4 Standard 4: Water Quality Volume

Standard 4 states that "stormwater Management systems shall be designed to remove 80% of the average annual post-construction load of Total Suspended Solids" from a volume of stormwater runoff. This volume is also known as the Water Quality Volume and is defined in the

handbook as a depth over the impervious contributing area. Since our basin is near the Wachusett Reservoir, a resource protection area, a depth of 1 inch was used. Equation 7 from the handbook was used to determine the water quality volume in order to submit an application to the local Conservation Commission, and to DEP for a Water Quality Certification if alteration of a wetland resource is proposed. Additionally, a sediment forebay was put in place to help remove additional sediment.

$$V_{WQ} = D_{WQ} \times I$$

EQUATION 7

$$V_{WQ} = 1in \times 6.2 \text{ acres} = 22,506 \text{ ft}^3$$

V_{WQ} = Required Water Quality Treatment Volume

D_{WQ} = Water Quality Depth

I = Impervious Area (pavement and rooftop area on site)

5.2.5 Standard 5: LUHPPL

Standard 5 is for Land Uses with Higher Potential stormwater Pollutant Loads (LUHPPL) and since MassDOT does not consider roadways a LUHPPL, this standard is not applicable to our design.

5.2.6 Standard 6: Critical Area Discharges

Standard 6 is for "stormwater discharges within the Zone II or Interim Wellhead Protection Area of a public water supply, and stormwater discharges near or to any other critical area, require the use of the specific source control and pollution prevention measures and the specific structural stormwater best management practices determined by the Department to be suitable for managing discharges to such areas." Discharges in these areas must comply with 314 CMR 3.00 and 314 CMR 4.00. 314 CMR 3.00 is a permit for surface water discharges (MassDEP, 2007). 314 CMR 4.00 is the Massachusetts surface water quality standards (MassDEP, 2013). Figure 57 shows that our project basin location is within a Zone A, Public Surface Water Supply Sources, area and therefore is considered a critical area and would have to comply with both 314 CMR 3.00 and 314 CMR 4.00. A Notice of Intent would have to be submitted to the MassDEP for the optimal basin design in order to gain a surface water discharge permit. If Stormwater Management Standards are met and the discharge permit is granted the surface water quality standards should be achieved.



FIGURE 57: ZONE A AREA (OLIVER, 2016)

5.2.7 Standard 7: Redevelopment

Standard 7 states "a redevelopment project is required to meet the following Stormwater Management Standards only to the maximum extent practicable: Standard 2, Standard 3, and the pretreatment and structural best management practice requirements of Standards 4, 5, and 6. Existing stormwater discharges shall comply with Standard 1 only to the maximum extent practicable." For the optimal basin this standard does not apply because everything currently in place would be removed before it is implemented. However, if redevelopment is chosen through alternative upgrades, this standard would have to be met.

5.2.8 Standard 8: Construction

Standard 8 requires that "a plan to control construction-related impacts including erosion, sedimentation and other pollutant sources during construction and land disturbance activities (construction period erosion, sedimentation, and pollution prevention plan) shall be developed and implemented." This standard should be addressed at the time of construction by the resident engineer. If the optimal basin is constructed a Construction Erosion and Sediment Control Plan would need to be filed and approved by the local Conservation Commission before it is implemented by the contractor.

5.2.9 Standard 9: O&M Plan

Standard 9 requires that "a long-term operation and maintenance plan shall be developed and implemented to ensure that stormwater management systems function as designed." The MassDOT Handbook provides a template for the preparation of a Stormwater System Operation & Maintenance (O&M) plan which can be used to create an O&M plan to be submitted and approved by the Conservation Commission for the basin if the optimal basin is constructed.

5.2.10 Standard 10: Illicit Discharges

Standard 10 states that "all illicit discharges to the stormwater management system are prohibited." MassDOT is in charge of maintenance for our project basin, since its location is off of I-190. Therefore, the optimal basin would comply with Standard 10 through MassDOT's IDDE Program described in their Stormwater Management Plan (MassDOT, 2009).

5.3 Alternative Recommendations for Current Project Basin

For the current project basin, improvements and additions could be made to maximize its function and efficiency if the optimal basin design is not feasible.

- Current vegetation in the project basin could be removed and/or native drought resistant plants can be added. This would help with the current issue of erosion and support current precipitation levels.
- Groundwater testing wells could be added to the basin to assist with future monitoring and testing, according to the placement on Figure 51.
- A trash rack could be placed near the inlet of the basin, collecting trash that accumulates during a storm, a major issue currently in the basin.
- A routine maintenance schedule could be developed so that the basin can reach its maximum potential and always be accessible.
- The fences surrounding the project basin could be removed per new suggestions made by the MassDOT.

The DCR through permission from MassDOT has the ability to utilize one or all of these upgrades to improve the current project basin. These are low cost additions and require little to no maintenance.

5.3.1 Road Salt Alternatives

During icy conditions MassDOT uses rock salt (NaCl) on roadways to improve driver safety. A pre-wet solution (MgCl) can be used as well if the conditions are correct and with proper timing. MassDOT uses 240 lbs. per line mile of rock salt which means 0.19 lbs. are used in the drainage area of the project basin (Kenna, 2016). Since Na levels were high in the basin the use of alternatives to rock salt could reduce those levels. Sand is an option but it has the potential of increasing TSS and unwanted sediment buildup in the basin (Winter Road Treatment and Snow Removal, 2017). MassDOT does work with a Pre-Mix Sodium Chloride/Calcium Chloride blend which is used in their reduced salt areas. This could reduce the amount of rock salt used on I-190 in the Wachusett Watershed while keeping roads safe for drivers. Although, the pre-mix is expensive it could save money for the water treatment plant which treats the Wachusett Reservoir. The switch could also decrease specific conductance levels in the river and reservoir and improve the wildlife in the surrounding area.

Chapter 6: Conclusion

The goal of our MQP was to achieve the following objectives:

Objective 1: Develop an understanding of the impacts of highway runoff to the watershed and the use of a stormwater treatment basin as a management technique.

Objective 2: Develop findings and identify deficiencies of the project basin.

Objective 3: Deduce recommendations for the DCR that will improve the project basin and maximize its potential for protecting water quality.

We accomplished objective 1 by researching and developing a thorough understanding of the Wachusett Reservoir and the stormwater treatment basins along I-190 represented in our Chapter 2 Background. We accomplished objective 2 in our Chapter 3 Methodology and Chapter 4 Results when we presented how we tested the basin's efficiency of trapping contaminants through field and lab procedures and analyzing the data. Lastly, in Chapter 5 Recommendations / Design we produced multiple recommendations for the current basin and designed an optimal stormwater BMP to accomplish objective 3.

The Massachusetts Department of Conservation and Recreation (DCR) wanted a better understanding of the basin and its effect on the treatment of stormwater runoff, specifically metals in the runoff. Through this project we gained a more in-depth understanding of the basin by the collection and analysis of data. The groundwater data for Mg in the results chapter displayed a decrease in Mg levels as the water moves through the basin. This demonstrated that the project basin was performing as expected by the DCR and captured metals between the time water entered as stormwater runoff and exited the basin via groundwater. Other metals tested showed reduced levels similar to Mg found in Appendix H: Data Sheets. TSS and specific conductance were also measured and decreased as water moved through the project basin, producing clearer and better quality water.

Although the project basin was working in some aspects, it could still be improved and become more efficient. The data collected on Na revealed the impact of de-icing the roadways in stormwater runoff and how the project basin allowed large levels of Na to easily move through the basin with minimal amounts captured. Through the increased treatment steps and the addition of native plants and soil with the potential for CEC in the optimal basin, there would be an increase in the levels of Na being captured within the basin. This would decrease the downstream effect on the watershed.

The increasing specific conductance in the Wachusett Reservoir during the winter months, which can be seen in Section 2.3.4.1 Specific Conductance, could be due to the metals that flowed

through groundwater from the treatment basins. These higher levels could be a result of the de-icing materials put on the road.

Limitations aside, the optimal basin design, shown in Figure 51, would be the best and preferred choice for the DCR to improve overall water quality of the outflow of this BMP and ensure that potential road spills would be captured in the basin. If this is not feasible, our team recommends that the DCR and MassDOT implement some of the lower cost alternatives and smaller recommendations.

- Plant native species that would improve the stabilization of the soils and increase water quality
- Remove existing fences
- Perform routine maintenance on the basins
- Add a trash rack to the inlet of the basin
- Implement permanent groundwater testing wells would allow for the DCR and MassDOT to continue monitoring the efficiency of the basin

This MQP answered the questions and concerns initially addressed by the DCR. Over the course of the project we came up with more questions and if time allowed we would have liked to explore deeper into these subjects. Some of these questions though could be answered by future MQP projects.

- Understand and document groundwater flow within the project site. We did not have the time or the tools to test for groundwater samples in multiple places around the basin. Accuracy of where the water from the basin was flowing would have led to a better understanding of the quality of water exiting the basin.
- Extrapolate the flow that enters all of the stormwater basins along I-190 in the Wachusett Watershed. By taking the known flow rates from our project basin and extrapolating the data to include all the other basins, we would have had a better understanding of how much runoff from the stormwater BMPs contributes to the reservoir.
- Extrapolate the total load gathered from our runoff data to the entirety of stormwater basins along I-190 to understand the amount of metals being deposited into the reservoir during a storm.

In conclusion, the data and recommendations provided to the DCR furthered the understanding of stormwater treatment basins, but continuous monitoring and adaptation of these basins would allow for effective stormwater management.

Chapter 7: References

- 2015 Water quality report*. (2016). Massachusetts Department of Conservation and Recreation. Massachusetts. 62.
- Benchmark limits developed, E. *Benchmark limits developed by EPA*. California: California Water Environment Association.
- Brown, K., & Lemon, J. (2017). Cations and cation exchange capacity.
- Commercial driver's license manual – 2005 CDL testing system*. (2005). Massachusetts: Massachusetts Registry of Motor Vehicles.
- Energy and Environmental Affairs. (2016). Wachusett Reservoir.
- Environmental assessment*. National Pollutant Discharge Elimination System, Environmental Protection Agency.
- Evanko, C. R., & Dzombak, D. (1997). *Remediation of metals-contaminated soils and groundwater*.
- Franklin, Hampden, Hampshire Conservation Districts. (2013). *Massachusetts erosion and sediment control guidelines for urban and suburban areas*. Massachusetts Executive Office of Environmental Affairs.
- Google. (2016). Google Maps: Wachusett Reservoir
- HydroCAD® . (2001). *HydroCAD® stormwater modeling system version 10 owners manual*. HydroCAD® Software Solutions LLC.
- Kenna, C., *MassDOT material usage on I-190*, September 9th, 2016
- Kenna, C., *MassDOT material usage on I-190*, February 24th, 2017
- Liners for stormwater management*. (2016). Minnesota Pollution Control Agency.
- Massachusetts Department of Conservation and Recreation Division of Water Supply Protection Office of Watershed Management. (2011). *Wachusett reservoir watershed 2011 public access plan update*. Massachusetts Department of Conservation and Recreation.
- Massachusetts Department of Environmental Protection. (2008) *Changes to the massachusetts stormwater management standards*. AMWS Newsletter.
- Massachusetts Department of Environmental Protection. (2007) *314 CMR 3.00: Surface water discharge permit program*.

Massachusetts Department of Environmental Protection. (2013) *314 CMR 4.00: Massachusetts Surface Water Quality Standards*.

Massachusetts Department of Transportation. (2017). *DRAFT MassDOT Stormwater Management Design Handbook*.

Massachusetts Department of Environmental Protection. (2008) *Massachusetts Stormwater Handbook*.

Massachusetts Department of Transportation. (2016). National Pollutant Discharge Elimination System.

Massachusetts Department of Transportation. (2009). NPDES stormwater management plan for MassHighway owned and operated highways.

Mengel, D. *Fundamentals of soil cation exchange capacity (CEC)*. Purdue University Cooperative Extension Service.

Misc. metals: Flood control, storm drains, storm sewer. (2012). Long Beach Iron Works.

Murphy, S. (2007). *General information on specific conductance*.

MWRA. (2016a). Archive of Wachusett Reservoir Levels: Massachusetts Water Resources Authority.

MWRA. (2015). *Metropolitan boston's water system history*.

MWRA. (2016b). *How the MWRA water system works*.

MWRA. (2016). *Water supply and demand*

NSPE. (2017). *Licensure. National Society of Professional Engineers*

Nilex. (2017). *Nilex All products*.

MA: Massachusetts Department of Environmental Protection and MassHighway. (2004). *Stormwater handbook for highways and bridges*. Commonwealth of Massachusetts

Pennsylvania Stormwater Best Management Practices Manual. (2013). Department of Environmental Protection. Bureau of Watershed Management.

Rawls, Brakensiek and Saxton. *Estimation of Soil Water Properties, Transactions American Society of Agricultural Engineers*. (1982).

Sewage Disposal System. (2015). David E. Ross Associates, Inc.

Smith, K. P., & Granato, G. E. (2010). *Quality of stormwater runoff discharged from massachusetts highways, 2005–07*.

Soil Map—Worcester county, massachusetts, northeastern part basin 16:07. (2016). Web Soil Survey National Cooperative Soil Survey.

Soil quality indicators. (2008).

Soil survey of norfolk and suffolk counties, massachusetts. (1989). Soil Conservation Service, United States Department of Agriculture.

StormRax™ racks and debris cages. (2017).

Tetra Tech, Inc. (2010). Stormwater Best Management Practices (BMP) Performance Analysis. United States Environmental Protection Agency

United States Department of Agriculture. (1986). *Urban hydrology for small watersheds: TR:55*

US Environmental Protection Agency. (2015). *Nonpoint source: roads highways and bridges*.

US Environmental Protection Agency. (2016a). *About the office of water*.

US Environmental Protection Agency. (2016b). *Problems with stormwater pollution*.

U.S. Geological Survey (USGS). (2016). *StreamStats*.

USBR water measurement manual - chapter 7 - weirs, section 12 cipoletti weir. United States Bureau of Reclamation.

Winter road treatment and snow removal. (2017). Massachusetts Department of Transportation.

Chapter 10: Appendices

Appendix A: Project Proposal

Evaluating the Role of Stormwater Basins in Water Quality

Worcester Polytechnic Institute
Major Qualifying Project Proposal

October 11, 2016

Elizabeth Desjardins, Julia Scott and Anna Valdez

Advisors: Professor Paul Mathisen and Professor Suzanne LePage

Table of Contents

Capstone Design	76
Environmental	76
Constructability	76
Sustainability	76
Economic	76
Social	77
Health & Safety	77
Section 1: Introduction	77
Section 2: Background	78
2.1 Wachusett Reservoir	78
2.2 Collaborative Partners	79
2.2.1 U.S. Environmental Protection Agency.....	79
2.2.2 Massachusetts Water Resources Authority.....	80
2.2.3 The Department of Conservation and Recreation.....	80
2.2.4 Massachusetts Department of Transportation.....	81
2.2.5 Worcester Polytechnic Institute	81
2.3 Stormwater Management	82
2.3.1 Interstate Stormwater Runoff.....	82
2.3.2 Best Management Practices	82
2.3.3 Stormwater Regulations	83
2.3.4 Quality Concerns.....	83
Section 3: Methodology	84
3.1 Scope	84
3.2 Objectives	85
3.2.1 Literature Review	85
3.2.2 Selection of Project Basin	85
3.2.3 Sampling and Data Analysis	87
3.2.4 Interpretation of Results.....	90
3.2.5 Formulate Recommendations	90
3.2.6 Extrapolation of Findings	91
Section 4: Expected Outcomes	91

Capstone Design

The Major Qualifying Project (MQP) for Worcester Polytechnic Institute Environmental Engineering major is required to have a Capstone Design as part of the final project deliverable. To meet the requirement for the project, an improved design and future recommendations will be given to the sponsor, the Department of Conservation and Recreation (DCR), for the basins adjacent to Interstate 190 (I-190) in the Wachusett Watershed. The project will be assessing one basin to analyze the function of the basin and the basin's efficiency at capturing pollutants. Through gaining a better understanding of the basin, improvements can be made which could be implemented for multiple basins in the I-190 region of the watershed. The design includes a plan to make sure that contaminants are held in the basin, reducing pollution entrance into the reservoir from I-190. The design would consider impact of the following areas: environmental, constructability, sustainability, economic, social, and health & safety.

Environmental

The environmental impacts of this project will be considered in the recommendations section of the report. The final recommendations will focus on improving efficiency of the basins that potentially impact the Wachusett Watershed. By improving the basins' ability to capture sediments and contaminants associated with runoff from I-190, the project will help to improve water quality in the Wachusett Reservoir.

Constructability

At the end of the project, the goal is to have a list of improvements that the DCR will be able to easily implement. Several of the basins have only one point of access and most have multiple trees and large shrubs surrounding them, making some basins challenging to enter. The feasibility of the solution is essential for the solution to be implemented into multiple basins along I-190 in the Wachusett Watershed.

Sustainability

The key to a quality product is to need minimal maintenance and to have longevity. The basins often become overgrown making them difficult to enter. The upkeep of the basins will preserve them allowing them to work effectively for a longer period of time. By creating a short and long term plan for the DCR to follow, it will allow them to improve multiple basins.

Economic

The equipment and materials that will be proposed in our report were considered due in part by their cost. Since the state has limited resources and wants to be fiscally responsible when making improvements the options were selected for the best quality and lowest cost.

Social

The improvements to increase efficiency have a large impact not just of the community that surrounds the reservoir but also the Boston community that drinks the water. By recommending upgrades and advancements to the basins, the goal is to have the water be of higher quality therefore the water will be less expensive to treat during the water treatment process. Higher quality of water means improved health for citizens and wildlife that live in the Wachusett Watershed.

Health & Safety

The DCR are concerned because of the unknown risk that the uncontained contaminants from the basins could leach into the Wachusett Reservoir which then feeds the greater Boston area. By deciding to collect groundwater, runoff, and soil data from several locations our team can gather a better understanding of what is flowing into and out of the basins. By receiving specific recommendations of how to improve the efficiency and quality of the basin we will improve the health and safety of the surrounding community.

In conclusion, the recommendations that will be made for this basin will revolve around what results are made from the data testing at the site. The improvements will increase efficiency of capturing contaminants in the basin and releasing clean water to the Wachusett Watershed. The runoff could hold potential hazards to the watershed and if a toxic spill happened on I-190 the basins need to be equipped with the preventative measures to inhibit contaminants from spreading too far.

Section 1: Introduction

In Massachusetts, reservoirs are a crucial component in providing clean drinking water. Maintaining a high quality of water in surface water bodies minimizes the amount of treatment required prior to distribution to the communities. The Department of Conservation and Recreation (DCR) monitors the Wachusett Reservoir, through sampling at water quality stations, which supplies water to the greater Boston area through the Massachusetts Water Resources Authority (MWRA).

A portion of the watershed and a number of tributary streams associated with the Wachusett Reservoir are in close proximity to Interstate-190 (I-190). Highways are a main source of runoff and accumulation of pollutants. Stormwater Best Management Practices (BMP) have been established in this region to control and maintain this runoff. The runoff is directed through some type of treatment before entrance into the reservoir to protect the water quality. The type of BMPs used along I-190 are stormwater basins, which are a detention basin, that temporarily

stores water during peak storms. They are typically found near roads with large amounts of traffic (*Pennsylvania Stormwater Best Management Practices Manual*).

The DCR has agreed to partner with our Worcester Polytechnic Institute (WPI) Major Qualifying Project (MQP) Team with the goal to evaluate the impact of the basins along I-190 in controlling runoff and develop appropriate recommendations to mitigate these impacts. These basins are crucial in controlling the impact of the runoff but the effects of these basins are not understood. Our sampling, testing and data analysis has a focus on load, conductance, heavy metals and Total Suspended Solids (TSS) because the DCR has stated these to be areas of concern that also have a lack of data. We have been given the task to collect data on these pollutants for the DCR. The following summary of objectives will help us accomplish our goal:

Develop an understanding of the impacts of highway runoff and of using a stormwater basin as a management technique.

- Review relevant literature regarding highway runoff and stormwater management
- From possible basins, select project basin to focus on for testing and analysis
- Perform sampling in the selected basin and analyze samples in the laboratory.

Develop findings and recommendations for DCR that will improve the basin and maximize the basin's potential for the region it is supporting.

- Interpret findings, compare the data to stormwater regulations and standards, and determine areas of concern for the basin.
- Develop a design and formulate recommendations for the DCR that will improve the basin and maximize the basin's potential for the region it is supporting. From findings develop a design component for the basin that encompasses the following areas: environmental, constructability, sustainability, economic, social, and health & safety.

Section 2: Background

This section aims to provide a basic understanding of the main topics of the project and provide a summary of relevant literature review. The topics begin with a broad understanding of the Wachusett Reservoir, progress to the parties associated with the reservoir, and conclude with the basics of stormwater runoff, regulations and best management practices. The process of reviewing past literature helps strengthen our team's understanding of the project and allows them to move forward with the development of the methodology.

2.1 Wachusett Reservoir

Forty-eight communities in Massachusetts receive their water from a combination of the Wachusett and Quabbin Reservoirs through purchasing contracts with the MWRA (MWRA,

2016). The MWRA incorporated the Wachusett Reservoir into its water system due to the continual growth of the Boston area. The Wachusett Dam was constructed in order to create the Wachusett Reservoir, resulting in the restriction of the flow of the Nashua River partially in the flooding areas of Boylston, West Boylston, Clinton and Sterling (MWRA, 2015). Since construction was completed in 1905 the reservoir has reached capacity at 4,135-acres surface area (Energy and Environmental Affairs, 2016). In 2015 with the additional input flowing from the Quabbin Reservoir the average volume of the reservoir was 58977-mg (MWRA , 2016a). The Wachusett Reservoir can be seen in Figure 1.

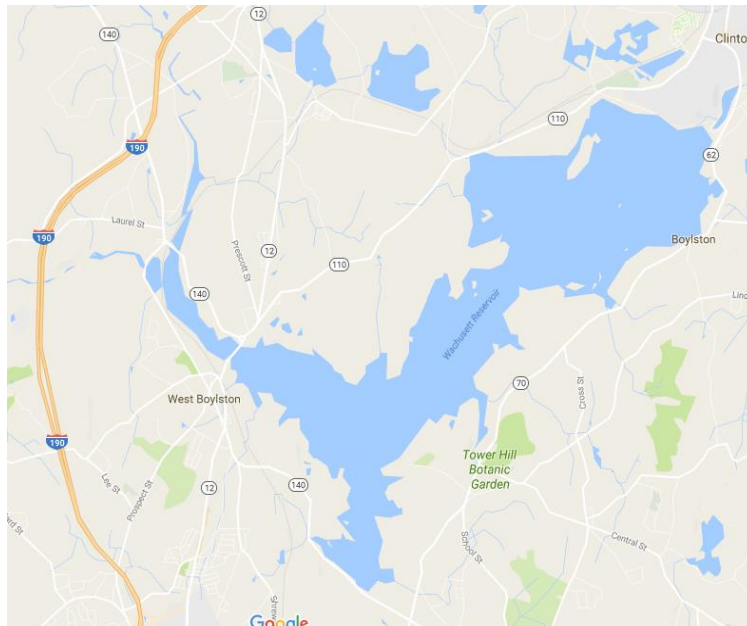

Figure 1: Wachusett Reservoir (Google, 2016)

2.2 Collaborative Partners

The reservoir is co-managed by the MWRA and the DCR. The parties must work together to follow the requirements, regulations and guidance provided by the US Environmental Protection Agency (EPA). Part of ensuring that they meet the EPA standards is working with the Massachusetts Department of Transportation (MassDOT) to ensure BMPs along roadways are being maintained to a regulated standard. The Worcester Polytechnic Institute (WPI) Team will take into account all parties during their project; working closely with the DCR while taking input from the MassDOT to complete the project.

2.2.1 U.S. Environmental Protection Agency

The EPA's Office of Water (OW) is tasked with ensuring that drinking water is safe for consumption while restoring and maintaining oceans and watersheds to protect both human life and ecosystems. They implemented both the Clean Water Act and Safe Drinking Act to ensure

the reduction of runoff and improvement of water quality. In Massachusetts the EPA is also responsible for implementation and oversight of the National Pollutant Discharge Elimination System permit program (Tetra Tech, Inc, 2010). The various stormwater management programs set up by the EPA are the guidelines our sponsor and the communities we are working in, need to comply to.

2.2.2 Massachusetts Water Resources Authority

The MWRA is responsible for the delivery and distribution of the reservoir water. To ensure they are providing reliable and quality water, they implemented the Integrated Water Supply/ Quality Program in addition to complying with the EPA's Safe Drinking Water Act (MWRA, 2015). The MWRA has to treat water if needed before it is distributed and therefore will use any data we can provide pertaining to the runoff that goes from the stormwater basins to the reservoir.

2.2.3 The Department of Conservation and Recreation

The DCR's responsibility for the Wachusett Reservoir is to keep the water supply clean and protected against various sources of contamination. The DCR oversees the 21,028 acres of land that contains the Wachusett Reservoir and the watershed which surrounds the reservoir as seen in Figure 2 below (2004, DCR). The DCR's oversight of the watershed area is important due to the reservoir being naturally replenished from precipitation that enters the watershed and makes its way to the reservoir. Although land surrounding the reservoir is a mix of forest and wetlands, there is also some development present such as roads, which increases the potential of contamination to the reservoir (MWRA, 2016). Stormwater basins are in place along the highways and some local roads, but the DCR would like to have a better understanding of the overall effectiveness and performance of them. With a better understanding of what is flowing into the basins and how the basins are capturing or releasing contaminants, the DCR will be aware of how they can contribute to effectively protecting the reservoir. The DCR would strongly prefer to have basins that can better protect the Wachusett Reservoir from potential risks and increase the overall health of the reservoir.

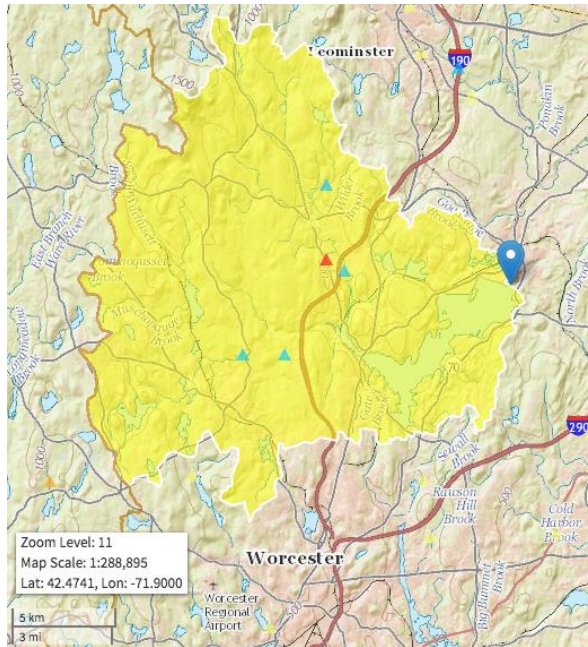

Figure 2: Wachusett Watershed (USGS, 2016)

2.2.4 Massachusetts Department of Transportation

MassDOT is listed as a contributing party because I-190 runs North to South on the west side of the reservoir as shown in Figure 2, which may cause risks to the quality of the water in the reservoir over a long period of time. Due to this there are added regulations and factors the MassDOT must consider while providing a safe and reliable transportation system. The MassDOT must abide by their Stormwater Management Plan that was granted with the approval of their Notice of Intent application for the EPA’s National Pollutant Discharge Elimination System General Permit for Stormwater Discharges from Small Municipal Separate Storm Sewer Systems (National Pollutant Discharge Elimination System, 2016). During construction of I-190, runoff/sediment basins were put into place to capture water runoff from the roads during storms. According to Vincent Vignaly, from the DCR, the basins in place today along I-190 were left after construction completion. Due to irregular inspections and maintenance by MassDOT, many basins access points are hard or impossible to enter.

2.2.5 Worcester Polytechnic Institute

The WPI team wants to effectively work with the DCR to create a deliverable that can be utilized and ideally implemented to improve the water quality of the Wachusett Reservoir in regards to stormwater basins. Our team needs to ensure that along with the data and recommendations provided, there is also a design element. In addition, we want to learn new skills and gain knowledge in concern with runoff, groundwater, soil, contamination impacts, watershed characteristics, sampling collection, and testing.

2.3 Stormwater Management

According to the EPA, “Stormwater runoff is generated from rain and snowmelt events that flow over land or impervious surfaces, such as paved streets, parking lots, and building rooftops, and does not soak into the ground.” This is problematic because as the water moves over the land or impervious surfaces it picks up various sources of contaminants and carries them to rivers, lakes, reservoirs, etc. threatening their water quality (EPA, 2016b). Specifically, road runoff can contain heavy metals, oils, debris and other toxic substances that are generated from construction, road maintenance and traffic (Nonpoint Source: Roads Highways and Bridges, 2015). BMP’s are used to help mitigate the effects of these contaminants to surface water.

2.3.1 Interstate Stormwater Runoff

Recently, multiple studies have been conducted pertaining to stormwater runoff to discover what is coming off of highways, the quantity of these contaminants, and why these contaminants are present. The largest study recently done was by MassDOT, in partner with US Department of Transportation and USGS; *Quality of Stormwater Discharge from Massachusetts Highways; 2005-07*. The study looked at twelve sites along multiple highways with different amounts of traffic for two years by using automatic samplers. The samples looked at runoff amount, turbidity, pH, recoverable metals, and much more. The results showed that during rain storms and snowmelt, more pollutants are contained in the run off. pH was also seen to fluctuate depending on time of year, and runoff quantity. The study conclusively found that deicing materials and maintenance sand are the leading contributors to spikes of pollutants in levels during winter months. The levels of chloride, nitrogen, total-recoverable metals, phosphorous, iron, and manganese, rose over the two years due to fuels, lubricants, antifreeze, windshield fluids, deicing, maintenance sand, and other automotive components (Smith, 2002). These increased levels are not as common next to less busy roadways.

2.3.2 Best Management Practices

Best management practice are in place to mitigate the entrance of sediment and contaminants into the surface water and groundwater. The BMP we focus on in this project is a sedimentation basin. According to the *Massachusetts Erosion and Sediment Control Guidelines*, sediment basins are a “settling pond with a controlled stormwater release structure used to store and collect sediment” and “usually consist of an earth dam, spillway to carry normal water flow, and an emergency spillway for storm flows.” Often sediment basins are built to collect sediment during construction and later remain at the site to become detention ponds to collect stormwater runoff. In order for a construction sediment basin to be left as a permanent basin the collected sediment from construction must be removed. Basins have inlets known as weirs that can alter the flow of water into the basin or the flow between chambers. Basins also contain one or more chambers that divide the basin. Typically, the more chambers a sediment basin has the more

effective it is, however, sediment basins at best are only 70 - 80 percent effective. Therefore, it is important to understand what is not being trapped in the basin and where pollutants are going (Franklin, Hampden, Hampshire Conservation Districts, 2013).

2.3.3 Stormwater Regulations

The EPA has set standards in regards to the amount of pollutants that can be present in stormwater runoff through the Clean Water Act and National Pollutant Discharge Elimination System (NPDES). The NPDES sets up a permitting system through the EPA to regulate runoff with a focus on protecting drinking water sources. "Mass Highway Stormwater Handbook for Highways and Bridges" written in 2004 states Massachusetts specific guidelines for stormwater best management practices. These guidelines include controls for wetlands, untreated stormwater, and removal efficiencies. Additionally the "2015 Water Quality Report for the Wachusett Reservoir Watershed" includes historic data to be used as a comparison for values our team collects.

2.3.4 Quality Concerns

In order to ensure the continued flow of high water quality into the reservoir, the DCR performs routine sampling, analysis, and patrolling of the surrounding tributaries. From the water quality data of the surrounding tributaries and the reservoir collected in 2015, the DCR prepared a Water Quality Report. Based on the available data, the areas of focus of the report were bacteria, specific conductance, turbidity, and temperature.

2.3.4.1 Conductance

The DCR has stated that an area of concern and lack of detailed data and analysis is specific conductance. Specific conductance is the measurement of water to be able to support an electric current. Analyzing specific conductance can determine what ions are present in the runoff. Currently there are nineteen tributaries in the Wachusett Watershed region that are tested on a weekly or biweekly basis for specific conductance (*2015 Water Quality Report, 2016*). Potential general areas of concern that increased specific conductance are dissolved solids and runoff from vehicles and salts such as NaCl (Murphy, 2007).

The Quinapoxet and Stillwater Rivers are the two main tributaries to Wachusett Reservoir and are estimated to account for approximately 75 percent of annual inflow from the reservoir watershed. Measurements of conductivity in these rivers generally range between 60 and 240 uS/cm with an average value between 125 and 150 uS/cm (*2015 Water Quality Report, 2016*).

It is important to address areas of concern at their source or prior to entrance into the reservoir because it minimizes the need for additional treatment prior to distribution. Additionally,

numerous criteria need to be met according to the Federal Surface Treatment Rule or implementing filtration will be required (*2015 Water Quality Report, 2016*).

2.3.4.2 Heavy Metals

Heavy metals are a main area of concern with regards to stormwater runoff potentially impacting the water supply and aquatic life. Heavy metals are present on highways due to the use of automobiles. According to the EPA, lead, zinc and copper have the highest concentrations. While all three metals are present from automobiles, they each affect certain aspects of vehicles. Lead is present due to “leaded gasoline, tire wear, lubricating oil and grease, bearing wear, and atmospheric fallout” (*Typical pollutants in stormwater runoff, 2016*). Zinc is present from “tire wear, motor oil, and grease” (*Typical pollutants in stormwater runoff, 2016*). Copper is present in the runoff due to “metal plating, bearing wear, engine parts, brake lining wear, and fungicides and insecticides use” (*Typical pollutants in stormwater runoff, 2016*).

Road maintenance materials such as road salt (sodium chloride), sand (phosphorous, iron, and manganese), and liquid magnesium chloride all contribute to higher levels of metals on roadways during winter months. As a result, states that have to perform road maintenance due to snow should consider the impact that these additional pollutants have on the environment (Smith and Granato).

2.3.4.3 Total Suspended Solids

According to the “2015 Water Quality Report for the Wachusett Reservoir Watershed” “total suspended solids are those particles suspended in a water sample retained by a filter of 2µm pore size.” These particles can be naturally present or a result of human usage. In general “total suspended solids in Wachusett tributaries ranged from <5.0 mg/L to 22 mg/L, but only five of 110 samples contained more than the detection limit” in the 2015 report. TSS that accumulate in stormwater runoff come from pavement wear, road salt, debris, and vehicle exhaust emissions (*Total suspended solids (TSS) in stormwater, 2016*). Various prevention methods can be established to help reduce TSS values such as treatment, controls and pollution preventions.

Section 3: Methodology

3.1 Scope

The scope of this project is to evaluate the impact of the stormwater basins along I-190 in the Wachusett Watershed in controlling runoff and maintaining water quality. DCR wants to understand the function, operation and efficiency of the basins better. This will be completed through research of stormwater runoff, research of expected basin function according to design, sample collection of soil, runoff and groundwater, and laboratory analysis. The next step will be interpreting the findings into results and recommendations to provide DCR with an evaluation of

the stormwater basins located in the 1-190 section of the Wachusett Reservoir region. A suitable design component will be created according to the project findings.

3.2 Objectives

To reach our goal we will complete the following objectives:

1. Review relevant literature pertaining to all topics in this project, in particular stormwater management, BMP stormwater basins, contributing parties, and state and federal regulations.
2. Select project basin to focus on for sampling and data collection and analysis.
3. Perform sampling, according to the sampling plan we created, in the project basin and analyze samples collected in the laboratory. Repeat process as necessary and until enough data have been collected.
4. Our team will interpret findings, compare the data to documented standards stated in the Background Section, and determine areas of concern for the basin.
5. Formulate recommendations for the DCR based upon findings and areas of concern which will improve the basin and maximize the basin's potential for the region it is supporting. This includes a design that will help address the proposed recommendations.
6. Extrapolate basin findings to all basins located in I-190 region of the Wachusett Watershed as limitations allow.

These objectives will be described in greater detail below and updated as they become further developed.

3.2.1 Literature Review

For this MQP there is a numerous range of relevant literature to be reviewed. Relevant topics include stormwater management, BMPs, basin designs and function, water quality and regulations at local, state and federal level. Our sponsor has provided us with basin drawings/ designs, ArcGIS data, and many other articles. The credibility of our sources range greatly from past MQP reports, academic research, EPA guidelines, Massachusetts highway control, and state data, providing varying supportive information.

3.2.2 Selection of Project Basin

The project basin was selected after evaluation of various characteristics including accessibility, runoff, size, drainage area, and monitoring locations. To evaluate these characteristics we visited various basins in the watershed region per suggestion of the DCR from their expertise and knowledge of the area. The site visits were documented through field notes and we made observations based upon general understanding of how basins work and what they are supposed to accomplish. We also reviewed the construction plans for the basins and use GIS. Figure 4 below

provides a summary of the characteristics that were considered and which basins moved on to each level of evaluation. After reviewing these characteristics Basin 16:07 was selected as the project basin.

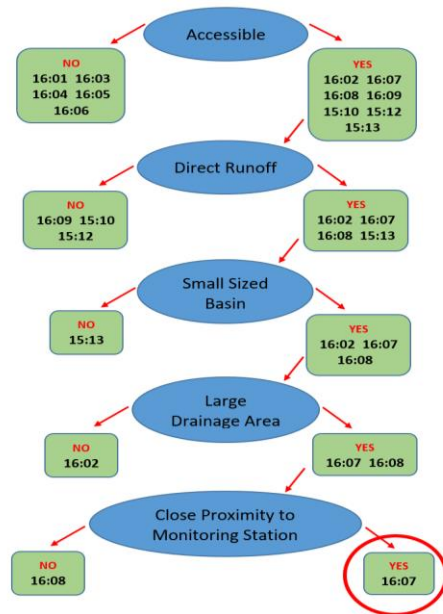

Figure 4: Basin Selection

3.2.2.1 Accessibility

The first criterion was to have a basin with easy entry to allow for the completion of sampling. Members of the DCR, including Daniel Crocker, visited all potential basin sites at the commencement of the project to determine their accessibility. Later, members of our team visited the basins that were not clearly ruled out as inaccessible along with the members of DCR to evaluate their conditions. Many basins had not been maintained in several years therefore the locks were stuck or the basins were too overgrown to drive or walk through. Photo 1 demonstrates a basin with adequate access while Photo 2 demonstrates an inaccessible basin. Basins with inadequate access were crossed off the list and the remaining basins moved on to be evaluated according to the next characteristic.



3.2.2.2 Runoff

Runoff was the next characteristic the basins were evaluated for. It was important that the basin allowed for runoff samples to be taken directly from I-190, therefore it was necessary to have a basin that was in close approximation to the highway. The team evaluated the source of runoff by reviewing the construction plans and using google maps to locate catch basins. The findings were all confirmed during field visits. The basins that did not have direct pipe inlets for runoff from I-190 were taken off the list for potential basins and the remaining basins were further evaluated.

3.2.2.3 Size

The third characteristic of the basin that was reviewed was the size. Our team analyzed the basin through collecting and analyzing samples which required us to be conscious of the basins size. The size of the basin correlated how many samples would be required. A large basin would require a lot of samples, and the samples taken would have a higher likelihood of not being able to detect anything since the contaminants entering the basin would be more dispersed. Due to this the larger basins were crossed off the list.

3.2.2.4 Drainage Area

Once it was determined that the basins on the list were an adequate size their drainage area size also needed to be evaluated. A larger drainage area would maximize the chance of obtaining useful results from the samples taken due to the fact that they would have a larger volume of input. To determine the drainage areas of the basins the 2ft contours layer was used on GIS in parallel with the basin construction plans to determine the drainage area. Basin 16:02 was determined to have too small of a drainage area therefore was crossed off the list.

3.2.2.5 Proximity to Monitoring Station

Finally, our team decided on a basin that had the option of testing nearby water, such as a stream, pond or river, to compare how the samples differed. Of the basins remaining, Basin 16:07 has surface water closer to it for us to test. Both the Sterling River and Muddy Pond are downstream of Basin 16:07. From this conclusion and the previous evaluation steps mentioned, Basin 16:07 was chosen as the project basin.

3.2.3 Sampling and Data Analysis

Initially a detailed sampling plan was created that includes when, what and how samples will be collected and analyzed. The purpose of collecting samples is to determine the efficiency of the basin, to test this we will be looking at specific conductance, metals and TSS. Samples taken at

multiple locations of the basin will give us a well-rounded understanding of how the contaminants enter and move through the basin. The runoff water sample will be taken during a storm to determine what load is entering the basin. Soil samples will be collected to determine what contaminants are being trapped by the soils. The groundwater samples will be used to determine the substances that infiltrate the soil and verify if the substances leave or remain in the basin area. All of the samples will be tested in WPI's Kaven Hall Laboratory.

3.2.3.1 Location and Description

Picking locations for sampling and documenting the process and the specific location chosen is important. In Basin 16:07, shown in Figure 5, the blue triangles represent runoff water samples, the red triangles represent soil samples, and the green triangles represent groundwater samples.

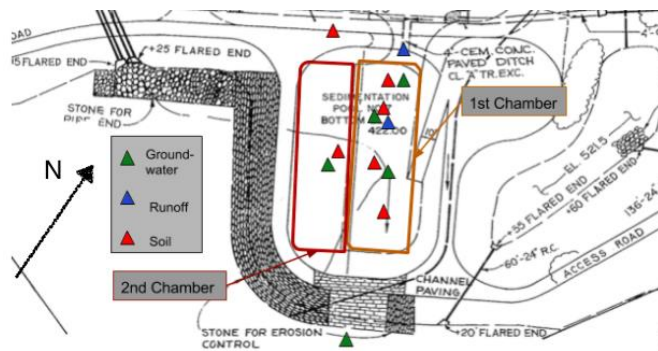

Figure 5: Basin 16:07 Sampling Plan

Runoff samples will be collected at the inlet of the basin at the cement inflow weir. The inflow weir is a single location where multiple runoff points collect. The second and third location for runoff water samples is in the basin itself. This might be slightly more challenging since most basins are dry, but our team wants to make sure that samples are taken at multiple locations of the basin.

Soil samples will be collected at the end of the inflow weir where a majority of sediments accumulate. Samples will also be collected at two locations, to allow our team to understand the types of sediments that are present in the basin. The team will also take a soil sample in the second chamber of the basin to understand the type of sediment flow from the first part of the basin to the second part of the basin. Changes in the soil type and amount of topsoil will give the team more information of soil flow.

Groundwater samples will be taken with a geoprobe or similar device to gather a better understanding of the movement of the pollutants. The samples will display how the contaminants are distributed; by weight of material or by multiple years of buildup. Tests will

near the proximity of the inflow weir, near the soil sample location, to see if the contaminants are leaching into the ground there. Groundwater samples will be collected in the second chamber of the basin and a fourth sample will be taken outside of the basin near the potential outflow to understand the groundwater movement.

In addition, to the above samples, samples will also be taken at two sources outside of the basin, one upstream and one downstream of I-190. Although, there are many contributing factors to the Sterling Stream, the stream that flows perpendicular to I-190, the data can give us a broader view of what the stream contains. The upstream sample will be taken from Sterling Stream at Crowley Road, Northwest of I-190. The downstream site will be taken at an USGS automatic monitoring station, number 01095220 which is on the Sterling Stream at John Dee Road, East of I-190. The station collects information about conductance, water levels, pH, and precipitation. We will be collecting our own samples to test for specific metals.

3.2.3.2 Samples

A list of the bottle sizes, material of the bottles, and what each bottle is used for will be documented in the final report. Multiple samples will be taken on multiple days if possible to obtain readings for the locations. The date, time, weather (rainfall data), and location will also be documented.

The metals that will be tested for will be: Copper (Cu), Cadmium (Cd), Chromium (Cr), Iron (Fe), Lead (Pb), Manganese (Mg), Nickel (Ni), Sodium (Na), Chloride (Cl), Sulfate (SO_2^{-4}), and Zinc (Zn). These are common metals found in road runoff as documented in the study conducted by Smith and Granato, "Quality of Stormwater Runoff Discharged from Massachusetts Highways, 2005–07". The research included many of these elements which helped our team narrow down which conductance to test for. These will be tested for in the water, soil, and groundwater samples.

The road salt remnants that will be tested for are: Calcium (Ca), Chlorine (Cl), Magnesium (Mg), Sodium (Na), and Sulfate (SO_2^{-4}). Learning what MassDOT uses on the roads during the winter on I-190 near the Wachusett Reservoir helped our team compile this list of what to test for (Kenna, 2016).

Nutrients will not be tested for because the DCR already has a lot of information on them. Nutrients typically come from homes and farms, not from roadways. Nutrients include phosphorus, potassium, and sulfur. Nitrate is another nutrient that does not need to be tested but due to other tests that we will be running this data will be therefore be given to us.

Runoff samples will test for total suspended solids (TSS). TSS are small solid particles that are suspended in water and help indicate the quality of water. We will test TSS in the lab by running one liter of the sample through a vacuum filter as outlined by standard methods.

The USGS water quality monitoring station tests for pH, temperature, precipitation, and specific conductance. This information will be used for analysis, however since this is an automatic collector our team will not need to take samples themselves except for when it comes to metal levels and TSS.

TSS samples will be collected in one liter bottles. Metal samples will be taken out of 250 milliliter bottles; those samples will be for runoff, surface water, and groundwater. Soil will be collected separately and dried out before testing.

3.2.3.3 Timing

The collected samples will be dated and individually numbered and the number of samples taken from each site will be recorded. One liter stormwater sample will be collected during each storm event that the team can capture. A table will be included specifying sample number, sample location, sample time/date, and what the sample was testing for. The timeline, found later in the paper, states that the samples will be collected beginning October 24th and continue until December 18th. Table 1 provides a basic outline of when certain samples can be collected and tested. We will collect multiple samples to ensure we get an accurate summary of the efficiency of the basin.

Day	Day 1	Day 2	Day 3	Day 4
Weather	Precipitation	No Precipitation	No Precipitation	No Precipitation
Task	Collect runoff, groundwater, and surface water samples.	Test samples in Laboratory	Collect soil, surface water samples, and groundwater If present	Test sample in Laboratory

Table 1: Sample Itinerary

3.2.4 Interpretation of Results

Once results have been produced, our team will first interpret these findings. Additionally these results will be compared to stormwater regulations and standards stated in the Background Section especially in concern with the DEP Stormwater Manual. The estimated annual pollutant loading from the highway runoff from metals, salts and TSS will be calculated. The point of suspension and the fate of the pollutants entering the basin will be determined as well. We will compare the analyzed data to what we expected from the basins based upon design models we created to determine areas of concern.

3.2.5 Formulate Recommendations

Recommendations will be made to the DCR in concern to the stormwater basins. These recommendations will aim to improve the basin and maximize the basin's potential for the region it is supporting. The recommendation that DCR selects for design improvements will be the bases for the development of our design element included in this project.

3.2.6 Extrapolation of Findings

There are a series of basins in the I-190 region of the Wachusett Watershed. Our team hopes to have a greater impact on the region as a whole by extrapolate findings and recommendations to all basins located in this section as limitations allow.

Section 4: Expected Outcomes

For this project, our team will evaluate the efficiency of the basins in the Wachusett Watershed and provide the DCR with data to be used to promote high water quality. The tasks timeline shown in Table 2 summarizes our general deadlines for the sections of the projects. The main points to highlight are to select the sampling site(s) by October 10th and to collect samples during all of B term in parallel with laboratory data analysis. The constraints are time, weather, and resources for the sampling plan.

In conclusion, our team is excited to work with their sponsor and advisors to learn more about stormwater runoff and basins and to provide the DCR with a useful deliverable.

References

- (2016). *2015 Water Quality Report*. Massachusetts Department of Conservation and Recreation. Massachusetts. 62.
- Benchmark limits developed. E. *Benchmark limits developed by EPA*. (). California: California Water Environment Association.
- Energy and Environmental Affairs. (2016). Wachusett Reservoir.
- Environmental assessment*. National Pollutant Discharge Elimination System, Environmental Protection Agency.
- Franklin, Hampden, Hampshire Conservation Districts. (2013). Massachusetts Erosion and Sediment Control Guidelines for Urban and Suburban Areas. Massachusetts Executive Office of Environmental Affairs.
- Google. (2016). Google Maps: Wachusett Reservoir
- Kenna, C., *MassDOT Material Usage on I-190*, September 9th, 2016
- Massachusetts Department of Conservation and Recreation Division of Water Supply Protection Office of Watershed Management. (2011). *Wachusett Reservoir Watershed 2011 Public Access Plan Update*. Massachusetts Department of Conservation and Recreation.

Massachusetts Department of Transportation. (2016). National Pollutant Discharge Elimination System.

Murphy, S. (2007). General information on specific conductance

MWRA. (2016a). Archive of Wachusett Reservoir Levels: Massachusetts Water Resources Authority.

MWRA. (2015). Metropolitan Boston's Water System History.

MWRA. (2016b). How the MWRA Water System Works.

MWRA Water Supply and Demand. (2016).

(2004). *Stormwater handbook for hiahwavs and bridges*. MA: Massachusetts Department of Environmental Protection and MassHighway.

Pennsvlvania Stormwater Best Manaagemnt Practices Manual: (2013).DEPARTMENT OF ENVIRONMENTAL PROTECTION; Bureau of Watershed Management.

Smith. K. P.. & Granato. G. E. (2010). *Quality of stormwater runoff discharged from massachusetts highways, 2005–07*.

Tetra Tech. Inc. (2010). Stormwater Best Management Practices (BMP) Performance Analysis. Total suspended solids (TSS) in stormwater. (2016).

Typical pollutants in stormwater runoff. (2016).

US Environmental Protection Agency. (2015). Nonpoint Source: Roads Highways and Bridges.

US Environmental Protection Agency. (2016a). About the Office of Water.

US Environmental Protection Agency. (2016b). Problems with Stormwater Pollution

U.S. Geological Survey (USGS). (2016). *StreamStats*. <http://streamstatsags.cr.usgs.gov>

Appendix B: Layout

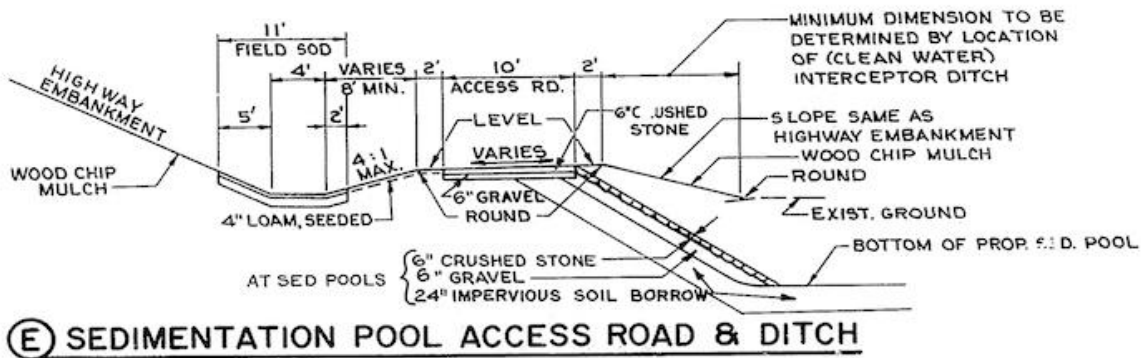

FIGURE 58: SIDE VIEW OF THE SEDIMENTATION POOL'S DITCH

As stated above, the water flowed from the road to a catch basin which directed the water through a series of pipes to a drainage ditch. Concrete ditches were used to transport runoff between the road and the basin itself. Figure 58 shows how the water was contained in the ditch due to the sloped edges, rather than moving into the basin.

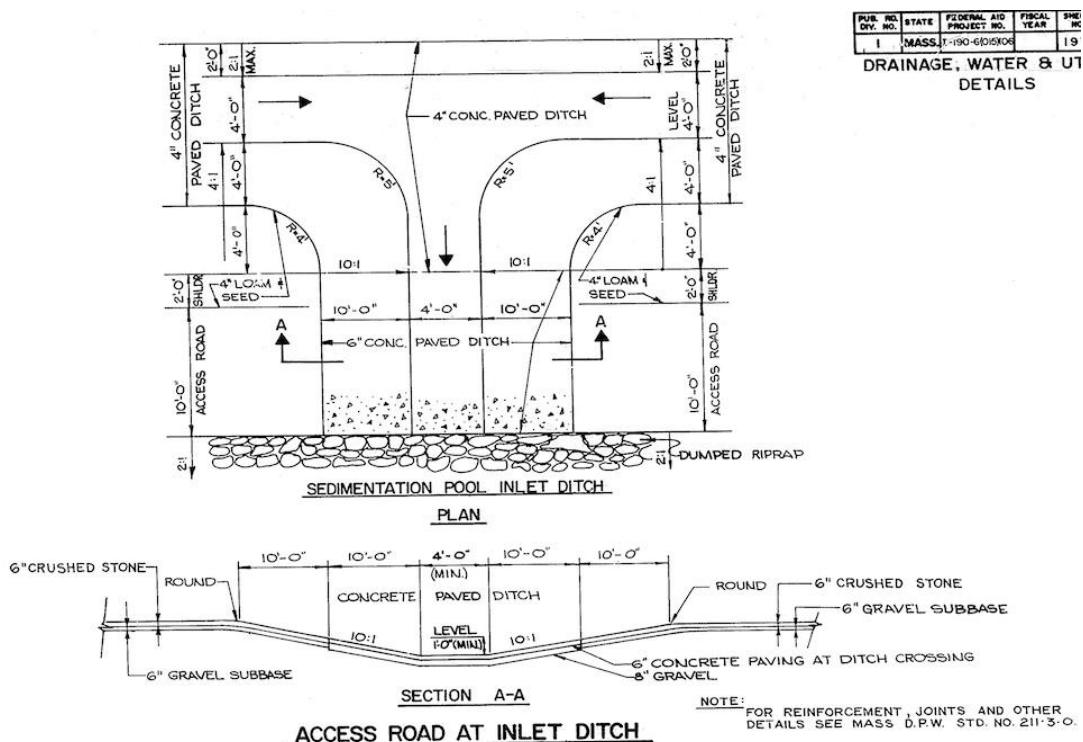

FIGURE 59: TOP AND SIDE VIEW OF INLET WEIR

Figure 59 shows the inlet ditch from two different views: top view and profile section. From the top view it can be seen how the concrete was formed to funnel the water toward the basin with the outer sides sloped. The side view of the inlet weir shows a better view of the 10:1 sloped edges.

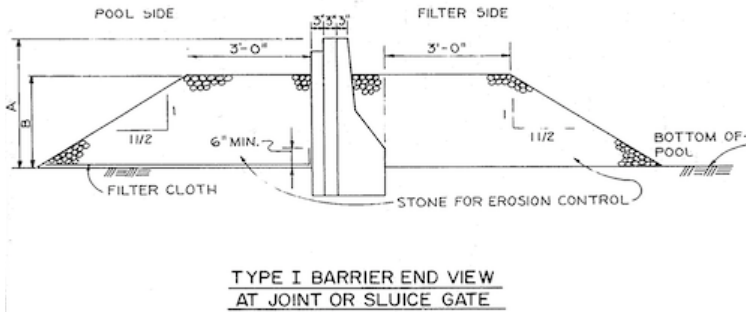

FIGURE 60: TYPE 1 OF BARRIER

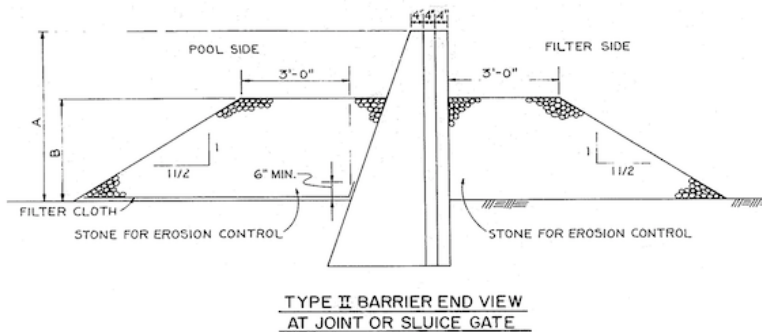

FIGURE 61: TYPE 2 OF BARRIER

Figure 60 and 61 shown above displays two types of barrier that can be found in basins between the chambers. Either type of barrier can be found in basins along I-190. The Chamber 1 is indicated on the left side and is called the “pool side” on the figures. The Chamber 2 is indicated on the right side and is called the “filter side” on the figures. Notice how both have stones built up on either side of the concrete weir wall for erosion control when the barrier is overtopped.

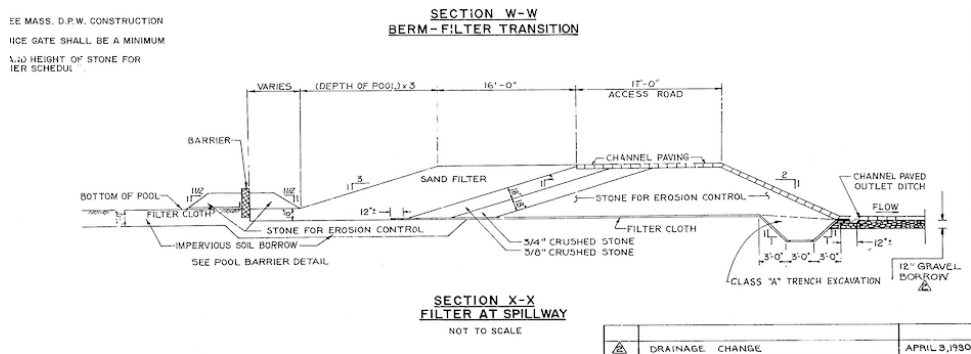

FIGURE 62: SIDE VIEW OF OUTLET WEIR

Figure 62 shows the outlet channel of the berm filter transition. There was crushed stone beneath the sand filter to increase infiltration into the soil and decrease future erosion. There was gravel outside of the basin which decreased erosion when water overflowed the basin.

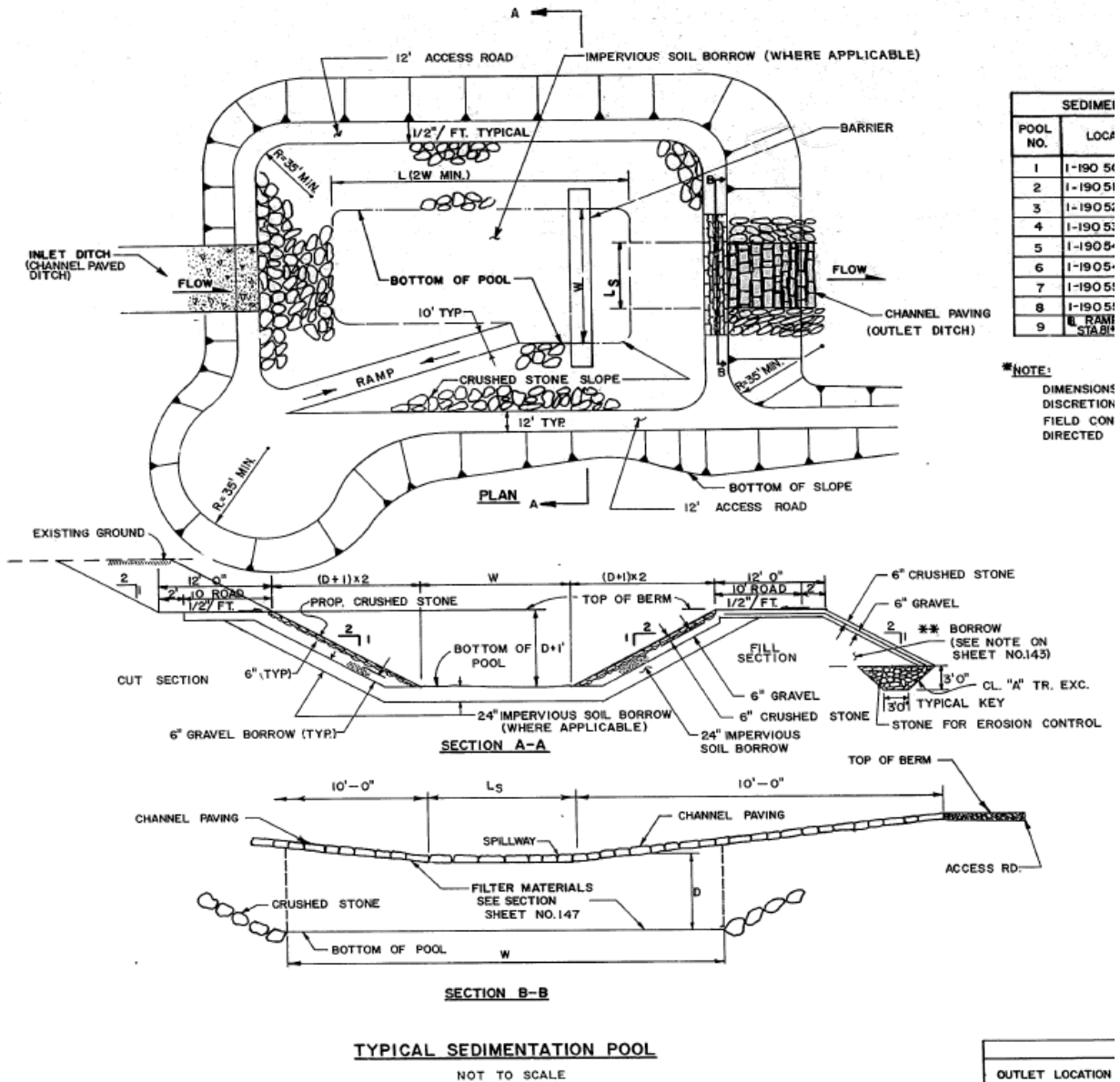

FIGURE 63: TOP VIEW AND SIDE VIEW OF THE BASIN

Figure 63 shows the top of a standard basin and the side view of the basin. These basins are designed to a standard that requires low maintenance over the course of several years. The slopes and materials were chosen to decrease erosion and to withstand large storm flows.

Appendix C: Thermometer Procedure

Temperature was measured at the Stillwater River and at the runoff pool when samples were collected as described in Table 16 because it is a parameter crucial to water quality. The temperature of water influences physical and chemical properties of the water.

TABLE 16: TEMPERATURE MEASUREMENT SUPPLIES AND PROCEDURE

Supplies	Procedure
<ul style="list-style-type: none">• Thermometer	<ol style="list-style-type: none">1. Place thermometer in water for 1 minute as shown in Figure 642. Read the temperature and record it in field notebook



FIGURE 64: MEASUREMENT OF TEMPERATURE

Appendix D: Lab Procedures
Appendix D: 1 Specific Conductance

To determine the rate of electric current in the sample the specific conductance was measured for each sample as described in Table 17.

TABLE 17: GROUNDWATER COLLECTION SUPPLIES AND PROCEDURE

Supplies	Procedure
<ul style="list-style-type: none">• ORION model 150• At least 100 mL of the sample• Beaker (100-mL to 250-mL)	<ol style="list-style-type: none">1. Place water from sample bottle into a beaker2. Clean specific conductance probe with DI water3. Place probe in water sample so the end is completely submerged as seen in Figure 654. When the machine says “ready” take reading5. Read numbers in microsiemens6. Compare results with USGS site if available

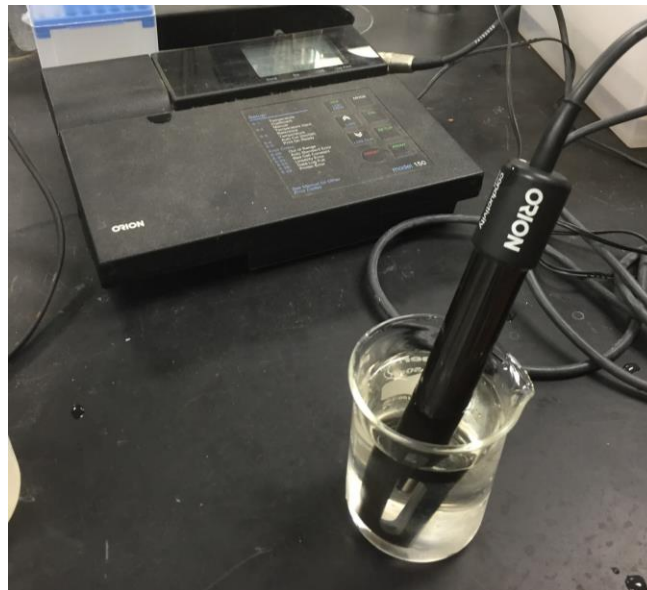

FIGURE 65: SPECIFIC CONDUCTANCE PROBE

Appendix D: 2 Total Suspended Solids

Total suspended solids (TSS) for various samples is measured to determine the amount of solids in the liquid trapped by a filter as described in Table 18. High concentrations for TSS correlates with poor water quality.

TABLE 18: TOTAL SUSPENDED SOLIDS SUPPLIES AND PROCEDURE

Supplies	Procedure
<ul style="list-style-type: none"> • Appropriately sized graduated cylinder • Filter • Tweezers • DI Water • Pans • Drying Oven • Magnetic Funnel Base for Vacuum Flasks • Vacuum Flask • KNF Neuberger Vacuum Pump • Khem Wipes 	<ol style="list-style-type: none"> 1. Wash and dry the Magnetic Funnel Base for Vacuum Flasks and place onto the Vacuum Flask 2. Place filter on Magnetic Funnel Base with tweezers 3. Wash filter with DI water with Vacuum Flask connected to KNF Neuberger Vacuum Pump <ol style="list-style-type: none"> a. Place water in funnel base before beginning vacuum b. Wet the new filter with DI water while being vacuumed c. Take tube off than take funnel off d. Remove filter and place into labeled pan e. Place in dryer for at least 24 hours 4. Clean scale with Khem wipes and zero out the scale using On/Off Switch 5. Weigh the dried filter on balance 6. Measure water sample with graduated cylinder to ensure at least 1L <ol style="list-style-type: none"> a. If sample has medium visible suspended solids decrease 1L to 100 mL b. If sample has lots of visible suspended solids decrease 100 mL to 50 mL c. Make sure to note which samples have decreased amounts 7. Filter sample with vacuum contraption KNF Neuberger Vacuum Pump <ol style="list-style-type: none"> a. Place DI water in before beginning vacuum b. Pour in sample as seen in Figure 66 c. Rinse graduated cylinder and Magnetic Funnel Base d. Take tube off than take funnel off e. Remove filter and place into labeled pan as seen in Figure 67 f. Place in dryer for at least 24 hours 8. Weight dried filter, and suspended solids on balance 9. Record data and subtract the dried filter weight from the dried filter and suspended solids weight

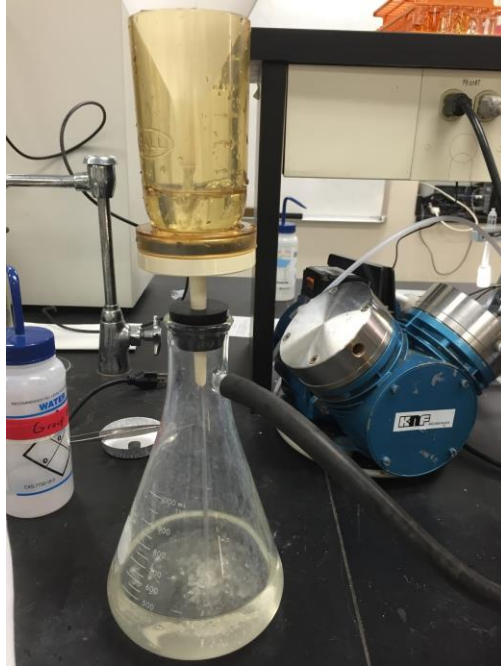

FIGURE 66: KNF NEUBERGER VACUUM PUMP



FIGURE 67: DRIED FILTER WITH SOLIDS PRESENT

Appendix D: 3 Test for Elements: Soil

Elements present in the soil samples were tested in the ICPMS Machine as described below in Table 19. Elements could be a source of contamination and knowing these levels helps understand the characteristics of the soil present in the project basin.

TABLE 19: SOIL SAMPLE SUPPLIES AND PROCEDURE

Supplies	Procedure
<ul style="list-style-type: none">• Soil samples• Drying Oven• Pans• Ziploc bags• ICPMS Machine	<ol style="list-style-type: none">1. Label small aluminum pans2. Add small amount of soil as seen in Figure 68<ol style="list-style-type: none">a. Make sure sample does not contain rocks or plants3. Place in drying oven4. Remove from oven at least 24 hours later as seen in Figure 695. Place in labeled Ziploc bags and put in back lab room6. Don uses acids to digest soils7. Test soils in ICPMS



FIGURE 68: PLACEMENT OF SOIL SAMPLE ON PAN



FIGURE 69: SOIL DRIED IN OVEN

Appendix D: 4 Test for Elements and Anions: Runoff and Groundwater

In the runoff and groundwater, the samples were tested for elements and anions in the ICPMS Machine and ICS Machine, respectively. Determining the levels of elements and anions present helps understand the levels of nutrients and contaminants present. Dissolved metals are measured by filtering out sediments present and testing the resulting filtered solution as described in Table 20. Digested metals measured by the collection of the total sample, where the sediments go through a process to be part of the solution that is tested as described in Table 21.

TABLE 20: DISSOLVED METAL SUPPLIES AND PROCEDURE

Supplies	Procedure
<ul style="list-style-type: none"> • 0.45 micron filter • Sample • Machine 	<ol style="list-style-type: none"> 1. Measure out 50 mL of sample 2. Put sample through filter 3. Place filtered sample in machine

TABLE 21: DIGESTED METAL SUPPLIES AND PROCEDURE

Supplies	Procedure
<ul style="list-style-type: none"> • Sample • Nitric Acid • Hydrochloric Acid • Hot Plate • Deionized water • Centrifuge • 0.45 micron filter • Machine 	<ol style="list-style-type: none"> 1. Shake sample bottle to get the sediment moving 2. Take out 50 mL of sample 3. Add 2 mL of nitric acid and 0.5 mL of hydrochloric acid to the sample 4. Put this on a hot plate, digest for 5 hours and then leave overnight to cool (sample will be reduced to 25 mL) 5. Add 25 mL of dionized water to bring sample up to 50 mL 6. Place in Centrifuge 7. Filter with a 0.45 micron filter 8. Place sample in the machine

Appendix E: Drainage Area

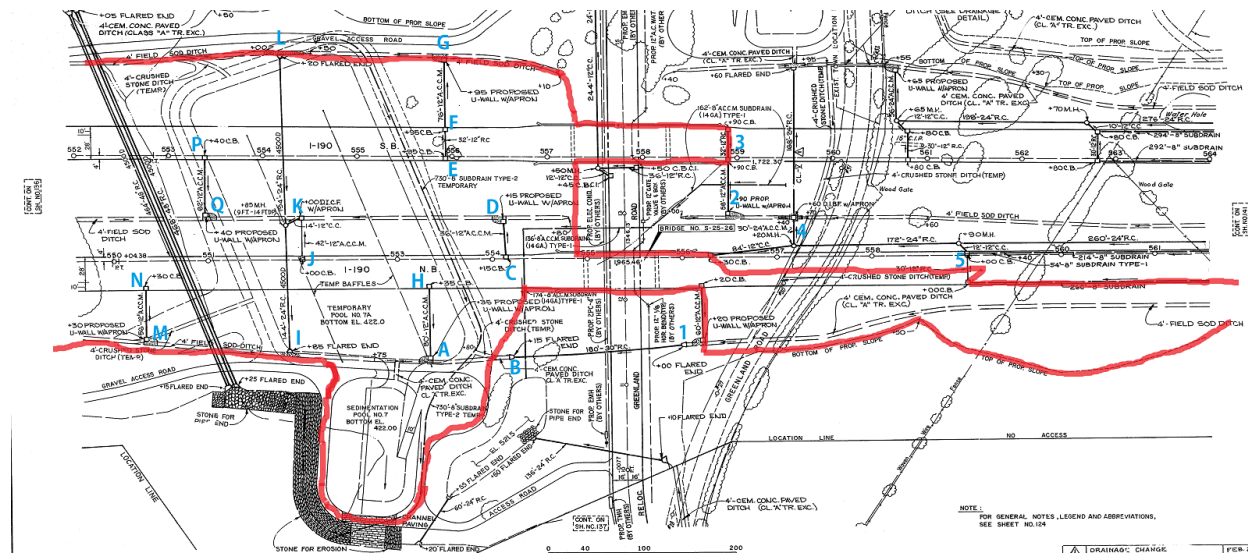
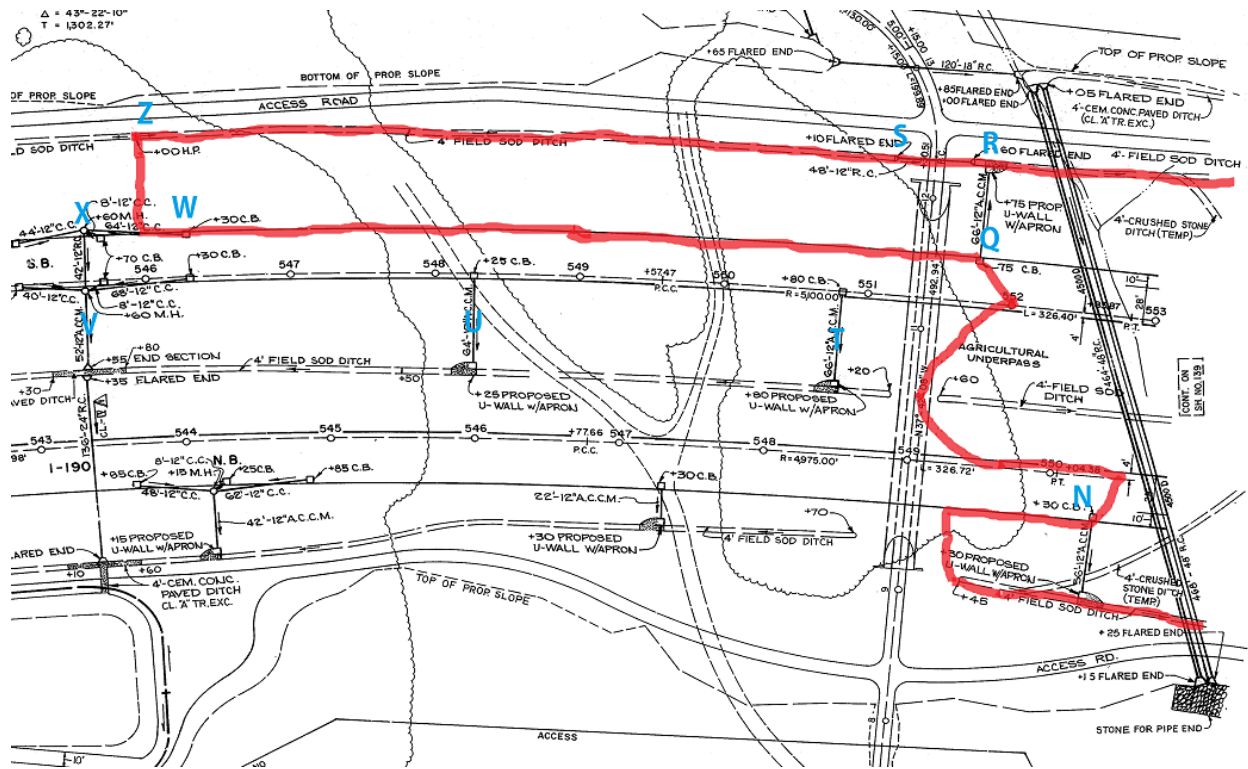

CONT. ON
SHEET NO. 152

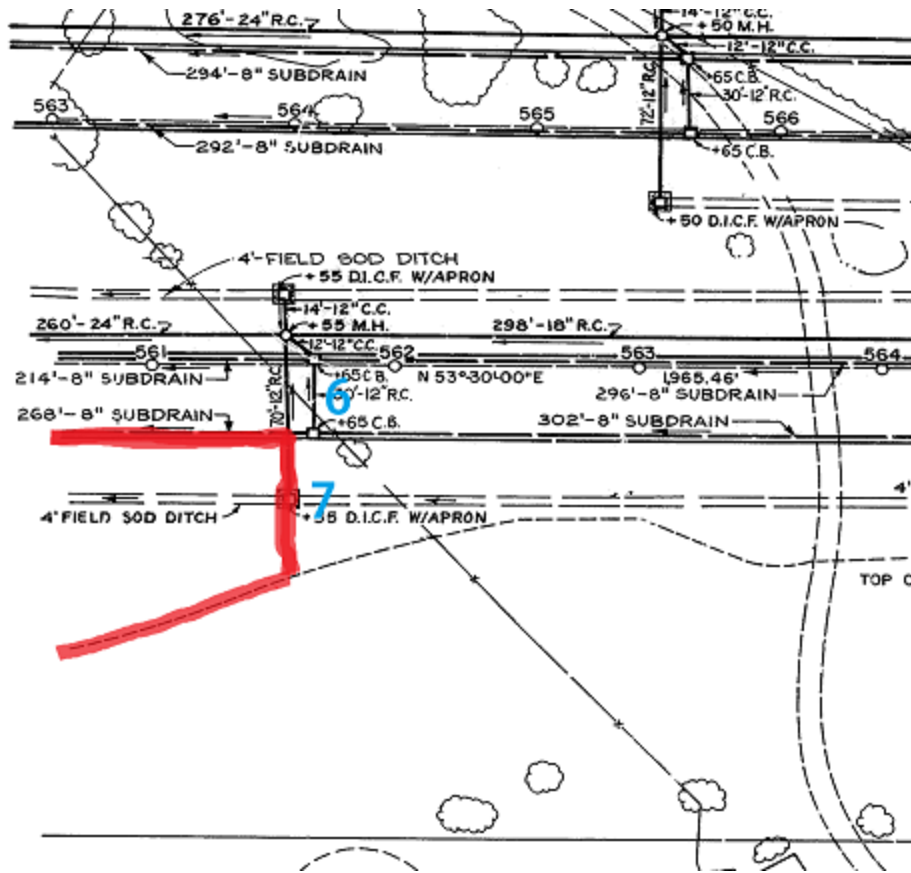

Appendix F: Flow Rates

Appendix F: 1 Cipolletti Weir Hand Calculations

For the weir we constructed at the project basin, the height of the weir (H) was 1/3 feet and the length of the weir was 1.5 feet. Table 22 shows the level of water for each collection time.

TABLE 22: FLOW RATES FOR STORM SAMPLES

Date	Sample Time	Level of Water (ft.)	Head (h) (ft.) (Level of Water - H)	Q (cfs)
11/15	14:46:00	0.37	0.0367	0.1852
11/15	15:17:00	0.39	0.0567	0.2862
11/15	15:50:00	0.44	0.1067	0.5387
11/15	16:15:00	0.41	0.0767	0.3872
11/15	16:50:00	0.44	0.1067	0.5387
11/29	15:07:00	0.35	0.0167	0.0842
11/29	15:38:00	0.39	0.0567	0.2862
11/29	16:07:00	0.39	0.0567	0.2862
11/29	16:40:00	0.39	0.0567	0.2862
11/29	17:08:00	0.4	0.0667	0.3367
11/29	17:38:00	0.42	0.0867	0.4377

Appendix F: 2 HydroCAD©

Project Basin 16_07 Type III 24-hr 100-Year Rainfall=6.50"
 Prepared by HydroCAD SAMPLER 1-800-927-7246 www.hydrocad.net Printed 2/20/2017
 HydroCAD© 10.00-19 Sampler s/n S19929 © 2016 HydroCAD Software Solutions LLC Page 7

This report was prepared with the free HydroCAD SAMPLER, which is licensed for evaluation and educational use ONLY. For actual design or modeling applications you MUST use a full version of HydroCAD which may be purchased at www.hydrocad.net. Full programs also include complete technical support, training materials, and additional features which are essential for actual design work.

Summary for Subcatchment 1S: Drainage Area

Runoff = 27.28 cfs @ 12.31 hrs. Volume= 3.150 af. Depth= 5.11"

Runoff by SCS TR-20 method, UH=SCS, Weighted-CN, Time Span= 0.00-48.00 hrs, dt= 0.05 hrs
 Type III 24-hr 100-Year Rainfall=6.50"

Area (ac)	CN	Description
6.200	98	Paved roads w/curbs & sewers, HSG A
0.535	35	Brush, Fair, HSG A
0.535	36	Woods, Fair, HSG A
0.040	49	Pasture/grassland/range, Fair, HSG A
0.030	73	Woods, Fair, HSG C
0.060	60	Woods, Fair, HSG B
7.400	88	Weighted Average
1.200		16.22% Pervious Area
6.200		83.78% Impervious Area

Tc (min)	Length (feet)	Slope (ft/ft)	Velocity (ft/sec)	Capacity (cfs)	Description
10.0	75	0.0300	0.13		Sheet Flow , Grass: Dense n= 0.240 P2= 3.00"
12.3	700	0.0040	0.95		Shallow Concentrated Flow , Grassed Waterway Kv= 15.0 fps
0.5	340	0.0300	12.47	39.18	Pipe Channel , 24.0" Round Area= 3.1 sf Perim= 6.3' n= 0.50' n= 0.013 Concrete pipe, bends & connections
0.1	150	0.0400	17.20	126.13	Parabolic Channel , W=11.00' D=1.00' Area=7.3 sf Perim=11.2' n= 0.013 Concrete, trowel finish
22.9	1,265	Total			

FIGURE 70: PROJECT BASIN 16:07 1S HYDROCAD© OUTPUT

This report was prepared with the free HydroCAD SAMPLER, which is licensed for evaluation and educational use ONLY. For actual design or modeling applications you MUST use a full version of HydroCAD which may be purchased at www.hydrocad.net. Full programs also include complete technical support, training materials, and additional features which are essential for actual design work.

Summary for Pond 1P: Basin

Inflow Area = 7.400 ac, 83.78% Impervious, Inflow Depth = 5.11" for 100-Year event
 Inflow = 27.28 cfs @ 12.31 hrs, Volume= 3.150 af
 Outflow = 19.14 cfs @ 12.55 hrs, Volume= 3.150 af, Atten= 30%, Lag= 14.7 min
 Discarded = 1.59 cfs @ 12.55 hrs, Volume= 2.426 af
 Primary = 17.55 cfs @ 12.55 hrs, Volume= 0.724 af

Routing by Stor-Ind method, Time Span= 0.00-48.00 hrs, dt= 0.05 hrs
 Peak Elev= 426.26' @ 12.55 hrs Surf.Area= 9,854 sf Storage= 48,943 cf

Plug-Flow detention time= 241.2 min calculated for 3.147 af (100% of inflow)
 Center-of-Mass det. time= 241.2 min (1,045.7 - 804.5)

Volume	Invert	Avail. Storage	Storage Description
#1	421.00'	49,366 cf	65.00'W x 135.00'L x 5.30'H Prismaoid Z=0.5

Device	Routing	Invert	Outlet Devices
#1	Primary	426.00'	50.0' long x 15.0' breadth Broad-Crested Rectangular Weir Head (feet) 0.20 0.40 0.60 0.80 1.00 1.20 1.40 1.60 Coef. (English) 2.68 2.70 2.70 2.64 2.63 2.64 2.64 2.63
#2	Discarded	421.00'	5.340 in/hr Exfiltration over Wetted area Conductivity to Groundwater Elevation = 390.00'

Discarded OutFlow Max=1.59 cfs @ 12.55 hrs HW=426.26' (Free Discharge)
 ↳2=Exfiltration (Controls 1.59 cfs)

Primary OutFlow Max=17.47 cfs @ 12.55 hrs HW=426.26' (Free Discharge)
 ↳1=Broad-Crested Rectangular Weir (Weir Controls 17.47 cfs @ 1.36 fps)

FIGURE 71: BASIN 16:07 1P SUMMARY HYDROCAD® OUTPUT

This report was prepared with the free HydroCAD SAMPLER, which is licensed for evaluation and educational use ONLY. For actual design or modeling applications you MUST use a full version of HydroCAD which may be purchased at www.hydrocad.net. Full programs also include complete technical support, training materials, and additional features which are essential for actual design work.

Summary for Pond 1P: Basin

Inflow Area = 270.072 sf, 100.00% Impervious, Inflow Depth = 6.26" for 100-Year event
 Inflow = 25.44 cfs @ 12.30 hrs, Volume= 140,918 cf
 Outflow = 13.30 cfs @ 12.65 hrs, Volume= 140,918 cf, Atten= 48%, Lag= 21.3 min
 Discarded = 1.63 cfs @ 12.65 hrs, Volume= 121,302 cf
 Primary = 11.67 cfs @ 12.65 hrs, Volume= 19,616 cf

Routing by Stor-Ind method, Time Span= 0.00-48.00 hrs, dt= 0.05 hrs
 Peak Elev= 426.20' @ 12.65 hrs Surf.Area= 9,735 sf Storage= 56,608 cf

Plug-Flow detention time= 282.1 min calculated for 140,771 cf (100% of inflow)
 Center-of-Mass det. time= 282.2 min (1,041.8 - 759.7)

Volume	Invert	Avail. Storage	Storage Description
#1	420.00'	56,645 cf	90.00'W x 95.00'L x 6.20'H Prismaoid Z=0.5

Device	Routing	Invert	Outlet Devices
#1	Primary	426.00'	50.0' long x 15.0' breadth Broad-Crested Rectangular Weir Head (feet) 0.20 0.40 0.60 0.80 1.00 1.20 1.40 1.60 Coef. (English) 2.68 2.70 2.70 2.64 2.63 2.64 2.64 2.63
#2	Discarded	420.00'	5.340 in/hr Exfiltration over Wetted area Conductivity to Groundwater Elevation = 390.00'

Discarded OutFlow Max=1.63 cfs @ 12.65 hrs HW=426.19' (Free Discharge)
 ↳2=Exfiltration (Controls 1.63 cfs)

Primary OutFlow Max=11.51 cfs @ 12.65 hrs HW=426.19' (Free Discharge)
 ↳1=Broad-Crested Rectangular Weir (Weir Controls 11.51 cfs @ 1.18 fps)

FIGURE 72: OPTIMAL BASIN 1P SUMMARY

Appendix G: Field Notes

Appendix G: 1 Field Visit 9-26-2016

I-190 Stormwater Field Visit

Date: September 26, 2016 @ 1:00 pm

Weather: 61°, Sunny

Attendees: Dan Crocker, Elizabeth Desjardins, Paul Mathisen, Julia Scott, Anna Valdez, Vincent Vignaly

Basin 16 – 8

- Is the standard basin design we have been seeing with the two chambers, stone ditch and ramp
- The adjacent land is owned by DCR so there are no trespassing concerns
- There is a washout of sediment creating a plunge pool that has caused a high point with high plant growth, would be an ideal place to sample
- Dan believes that soil and bearing samples exist somewhere
- Would have to build a weir in the channel to be able to test flow rate
- Could potentially put a cloth fence in the basin to trap water in order to localize the infiltration to get groundwater samples
- In 2004/2005 they removed sediment returning back to an even grade



Figure 1: Basin 16-8

Figure 2: Sediment Plunge Pool



Figure 3: Discharge Pipe to Basin Weir

Basin 16- 7

- Was changed after construction, made smaller after road work was completed
- Could potentially put sandbags along fence to be able to measure flow - would be a lot of work and may be able to get what is needed from a desktop analysis
- Important to figure out what we want to find out/test before we take steps that cost money/ time to sample
- Pipe -> Weir , estimate pipe is half full to determine what the weir size will need to be
- Will be dealing with flashy drainage areas (watershed is usually used for larger areas made up of many drainage areas, also called Catchments) since there is a lot of impervious area due to road



Figure 4: Basin 16-7



Figure 5: Inflow Weir

Basin 16: 2

- Sediment was pulled out in 2004
- Lots of cattails
- Some water was present in the basin
- Was made smaller after construction of the road
- There is an old spring well nearby which means there is high groundwater which may be the reason why there was water present in the basin
- Path to get to basin and near inlet is overgrown with poison Ivy present



Figure 6: Overgrown



Figure 7: Water in the Basin



Figure 8: Inflow Weir

Appendix G: 2 Field Visit 10-27-2016

I-190 Stormwater Field Visit

Date: October 27, 2016 @ 5:20 pm - 6:20 pm

Weather: 60°, Rain

Attendees: Elizabeth Desjardins, Anna Valdez

Basin 16 – 7: Observation of Rain Event

- It was noticed that MassDOT had cleared up the site for vehicle access
- Trash was scattered around the premise of the basin, likely from the flash floods the week prior
- There was flow entering the basin that will be able to be used for sampling



Figure 1: Flow into the basin

- Rain was constant during the entire site visit and was a more than a drizzle but not pouring
- Participation Figures from the USGS sampling location nearby are provided below for reference

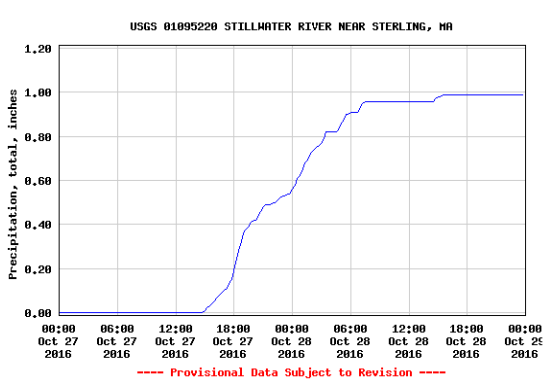

Figure 2: Precipitation Data of Full Storm

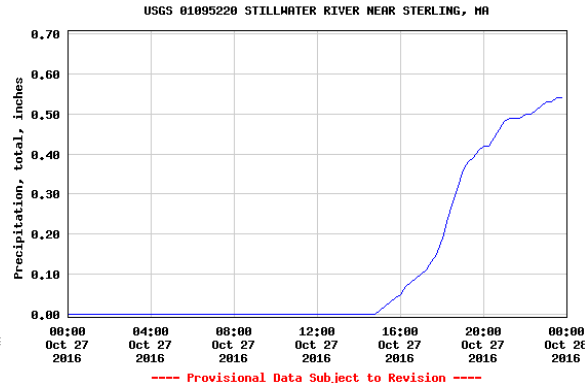

Figure 3: Precipitation data of October 27th

- Debris lined the fence which restricted flow into the basin and caused pooling in the swale



Figure 4: Precipitation data from October 27th



Figure 5: Precipitation data from October 27th

- There was a washout of sediment at the end of the concrete creating pooling
- At the beginning of the site visit water was only pooling in the area blocked by sediment but at the end of the site visit the water had started to flow further into the basin



Figure 6: Pooling at 5:30 pm



Figure 7: Pooling at 6:15 pm

Appendix G: 3 Field Visit 11-2-2016

I-190 Stormwater Field Visit

Date: November 2, 2016 @ 8:00 am - 11:00 am

Weather: 55°F, Sunny

Attendees: Elizabeth Desjardins, Paul Mathisen, Julia Scott, Anna Valdez, Vincent Vignaly

Basin 16 – 7: Initial Day of Sampling

- Upon arriving at the site the team conducted a basic walk through of the site. It was observed that the site had no standing water and there was additional litter within the basin. Overall they did not observe any major changes.
- The sediment build up that was causing pooling during the last site visit (10/27/16) was observed for further detail and photographs were taken to reveal water was no longer present.



Figure 1: Sediment Build Up

- Due to only two groundwater sampling devices being available for the team to use, the team located two areas most suitable for testing groundwater at. The first location was approximately 19 feet out from the inlet and roughly in the center of the first chamber.
- At the groundwater sampling location a shovel was first used followed by a coring device to dig an approximately 1.5 foot hole. The groundwater device was then placed into the hole and surrounded with small rocks to prevent the filter from being clogged with sediment.
- A soil sample was extracted from the coring device and revealed that the soil at this depth only included the lower layer of lighter ground below the sediment layer.
- The hole was then filled back in and the groundwater device was left until the first storm event.
- The Geopump for the groundwater devices was tested to make sure the piping fit but the pump was brought back to the lab.
- The second groundwater device was placed outside the outfall of the basin in an area that appeared to contain a larger amount of moisture.



Figure 2: Removing Topsoil with Shovel



Figure 3: Removing Lower Soil with Coring Device



Figure 4: Lower Soil Used for Sample S1



Figure 5: Groundwater Device Surrounded by Small Stones



Figure 6: Groundwater Sampling Device with Pump

- After the two groundwater devices were set the team continued to take soil samples. A total of 6 soil samples (S1-S6) were taken to bring back to the lab to test. To visually see approximate locations of the sample locations please reference the map attached to these field notes.
- The second sample, S2, was taken only 9 feet from the inlet where the sediment had built up. The coring device was used to take the sample. The soil was all dark sediment and the hole was a depth of 6 inches.



Figure 7: Taking Core for sample S2

- The third sample, S3, was taken on the other side of the basin, 98 feet from the inlet using the same technique as sample S2.
- Sample S3 was a mixture of topsoil/sediment and lower soil. Most of this mixture was made up of lower soil. At this location there was only 1.5 inches of sediment.
- The lower soil was able to be formed into a ribbon.



Figure 8: Hole left after taking Sample S3



Figure 9: Sample S3

- The fourth sample, S4, was taken in the second chamber of the basin near the weir. It was taken 76 feet from the inlet using the same technique as sample S2. This soil was sandy and mostly dry and consistent. A hole 1.5 feet deep was dug and there was no noticeable change in the soil.



Figure 10: Sample S4

- The fifth sample, S5, was taken near sample S1 and S2. It was taken 17 feet from the inlet using the same technique as sample S2. This soil was all sediment. A 1.5 foot hole was then dug and it was observed that there was 11 inches of sediment before the lower soil.
- The sixth and final soil sample, S6, was taken outside the fence next to the concrete swale as a control. There was 9 inches of topsoil before sand was reached. Only the topsoil was used for the sample.
- Before the team left the site they located the clean water bypass pipe to see if there was water present that could potentially be tested. Unfortunately there was no water.
- The team looked at the inlet weir to assess the possibility of using sandbags to determine flow.



Figure 11: Dry Clean Water Bypass



Figure 12: Inlet Weir

- On the way home from the basin the team stopped at three additional sites. Two sites were along the Stillwater Stream to take water samples and one was a spot along a stream that flows into the Stillwater stream to make observations.
- At the first location along the stream, upstream of the basin, samples A1-A2 were taken about 2 feet from the bank with sample bottle completely submerged in water. A liter bottle was used, A1, to test TSS and a 250 mL bottle, A2, was taken for the additional tests. The temperature was also recorded.

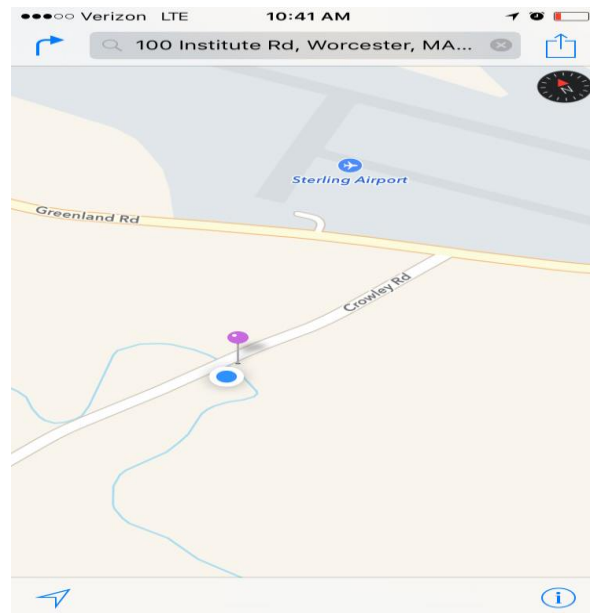

Figure 13: Location Along Stillwater Stream where A1-A3 was taken



Figure 14: Stillwater Stream where A1-A3 was taken



Figure 15: Sample A1

- The second location was along a stream that flows into the Stillwater stream to make observations. It was observed that the stream was flowing into the Stillwater at a fairly steady rate.

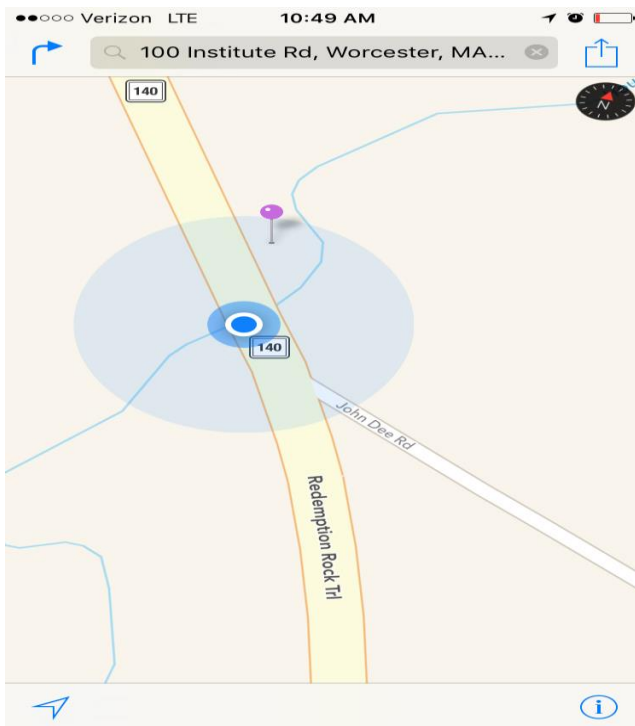

Figure 16: Stream that flows into Stillwater



Figure 17: Stream

- The third location, downstream of the basin, at the USGS Stillwater sample location, samples A3-A4 were taken using the same method as the first location.



Figure 18: Temperature Reading



Figure 19: USGS Sampling Location

- At the return of the trip all samples were stored in the fridge and all equipment was returned.



Figure 20: Samples in Fridge

Appendix G: 4 Field Visit 11-14-2016

I-190 Stormwater Field Visit

Date: November 14, 2016 @ 2:30pm-4:30pm

Weather: 63°F, Partially Cloudy (Sunset)

Attendees: Elizabeth Desjardins, Paul Mathisen, Julia Scott, Anna Valdez, Vincent Vignaly

Basin 16 – 7: Setup of Groundwater Devices

- Professor Mathisen prepared the materials for two more additional groundwater sampling devices prior to the field visit
- Mathisen brought two pvc pipes that have an interior diameter of .5" and a 1" nub on the bottom. The top was left open
- While at the site, Anna used a saw to make deeper slits in the bottom of the pvc pipe to allow for inflow



Figure 1: Cutting slits into groundwater devices

- At the groundwater sampling location a shovel was first used followed by a coring device to dig a hole to place the device in
- First device was placed in the first chamber in J8 at the depth of 15 inches
- Second device was placed in chamber two in H8 at the depth of 19 inches
- Once the groundwater device was placed in the hole, small pebbles were placed around the bottom to prevent clogging
- The hole was then filled back in with soil and the groundwater device was left until the first storm event



Figure 2: Coring device to dig hole



Figure 3: Groundwater device setup complete

Basin 16 – 7: Setup for Runoff Sampling of Upcoming Storm

- With the help of Professor Mathisen and Vinny we designed and built our Cipolletti Weir based upon a table that stated the discharge of standard Cipolletti weirs in ft^3/s
 - Initial Piece of Wood: 11 in by 4 ft
 - Used Head = 0.7 ft
 - 4 in from the bottom
 - 2.5 ft lengthwise, split in half with 1.25 ft on each side
 - 4 to 1 Slope to make the weir trapezoid shape
 - Tools: circular saw, measuring tape, pen and square



Figure 4: Construction of weir

- Once the weir was built we placed it at the top of the cement inlet
- A level was used to ensure the weir was even
- Sandbags were filled with sediment from the basin and placed around the weir to hold it in place and build up the inlet so that all the runoff will be directed through the weir and we could calculate flow



Figure 5: Filling of the sandbags



Figure 6: Setup of sandbags at weir



Figure 7: Completed setup of weir and sandbags

- The weir was left completely setup in preparation for storm event

Appendix G: 5 Field Visit 11-15-2016

I-190 Stormwater Field Visit

Date: November 15, 2016 @ 10:30am-5:00pm (5.5 hours)

Weather: 63°F, Partially Cloudy to Rain Storm depending on the time

Attendees: Elizabeth Desjardins, Julia Scott, Anna Valdez, Vincent Vignaly, Dan Crocker

Basin 16 – 7: Collecting Runoff Samples

- Upon arrival at the site, Elizabeth, Anna and Vincent took a look at the inlet weir flow setup



Figure 1: Top View of Weir Close up

Figure 2: Weir Overview

- The wooden weir was surrounded by small rocks on both sides of the wood and sandbags on the side to make a pooling area. A metal “L” was placed in front to slow down the runoff. The “mesh bag” was placed on the down-gradient side of the weir to reduce erosive forces and prevent undercutting.
- Other metal pieces and concrete blocks were added to encourage pooling within the gauge pool.
- One concrete block had a staff gauge, which read in feet, attached to it with duct tape.
- A rain gage was also set up to measure precipitation.



Figure 3: Rain Gage

- The rain gage was emptied before the start of the storm
- Elizabeth and Anna waited in the car for the rain which started at 1:10pm
- They left the site at 1pm
- When Julia and Anna arrived back on site at 2:00 pm the rain was pouring generously
- A puddle was forming behind the weir but not enough for a sample
- A sample was collected at 2:15pm because more water was in the basin but still not enough to flow over the weir.
- 3 samples were taken
 - 1 - 1 L bottle for TSS
 - 2 - 250 mL bottle for specific conductance and metals
- Other things noted
 - Height of pond
 - Temperature of water and air was noted
 - Amount of rainwater in gage was noted
- Water flowed over the weir at 2:45pm
- A sample was collected at 2:50pm and measurements were taken
- Figure 4 shows this moment



Figure 4: Weir with first water overflow

- Samples were then taken every half hour
 - 3:15pm, 3:50pm, 4:15pm, 4:50pm
- The peak of the storm hit around 4:15pm
 - The water got its highest over the weir
 - Shown in Figure 5



Figure 5: Basin during peak of the storm



Figure 6: Entrance to Weir at 4:15pm



Figure 7: Pond when last sample was taken



Figure 8: Site at 4:50pm

- Figure 6, 7, and 8 shows the site at the end of the sampling time
 - The sun had set so it was difficult to see
 - The back of the weir was a little damaged, most rocks were swept away with the rain
 - Sandbags worked but were saturated with water

- The weir did not keep 100% of the water pooled
- The pond size had decreased from earlier in the night

Basin 16 – 7: Basin

The basin began filling with water at 3:15

- As the storm continued the water flowed further into the basin but only in chamber 1
- At 4:30 Anna took two samples and some measurements from the basin
- Sample A-3, 250 mL water sample, was taken at Location I5 - edge on basin on the rocks between both basins. the water was 4" high in that spot
- Sample A-4, 250 mL water sample, was taken at Location H8, in basin 2 next to the weir. 3" of standing water was found.
- 4.5" of standing water was found in I9



Figure 9: Water Standing in Chamber 1



Figure 10: Chamber 1 with standing water



Figure 11: Chamber 2 with standing water at weir

Appendix G: 6 Field Visit 11-16-2016

I-190 Stormwater Field Visit

Date: November 16, 2016 @ 8:00am-10:15am

Weather: 50°F, Cloudy

Attendees: Elizabeth Desjardins, Julia Scott, Anna Valdez

Basin 16 – 7: Groundwater Sampling

- Elizabeth, Julia, and Anna visited the site the morning after the first sampling storm to observe and take groundwater samples
- The first observation made at the site was that the second half of chamber 1 still had surface water present and there was a small pool of water in the second chamber near the weir
- The first half of chamber 1, by the inlet was moist but there was no surface water present
- The weir that was constructed by the team to determine flow, was observed to be slightly damaged and will need minor repairs and additional reinforcement prior to the next storm



Figure 1: Second Half of Chamber 1



Figure 2: Pooling water in Chamber 2



Figure 3: First Half of Chamber 1



Figure 4: Damaged Weir

- After the team finished observing the site they began taking groundwater samples
- They took samples G1-G3 from the groundwater device in chamber 1 closest to the inlet. The device did not have any surface water around it.
- The team hooked the pump up to the tubing that was already in the groundwater pump and took three flushes and then three samples. Only the three sample bottles were saved, the three flushed were poured out. The flushes were initially kept in case there was not enough water to fill three more bottles.



Figure 5: Sampling at Location 1



Figure 6: Filling sample bottles at Location 1

- At the second location, in chamber 2, samples G4-G6 were taken. This groundwater device also had no surface water above it but the pooling water was only a few feet away. At this location the team stuck a tube down the pvc pipe and hooked the pipe up to the pump. Again they took three flushes and three samples and only kept the samples.



Figure 7: Sampling at Location 2

- The third location, Samples G7-G9, was in the middle of chamber 1. This location was surrounded by surface water so the team had to be careful to not get the pump near the water. They then proceeded with the same process as location 2.



Figure 8: Sampling at Location 3



Figure 9: Location 3 Flushes and Samples

- For the fourth location the team had to walk on the outside of the fence to get to the groundwater device past the outlet of the basin where samples G10-G12 were taken. This groundwater device was different than the other three and the team had to attach the tubing to the metal rod. Only one flush was able to be taken at this site but the water was visibly clearer.

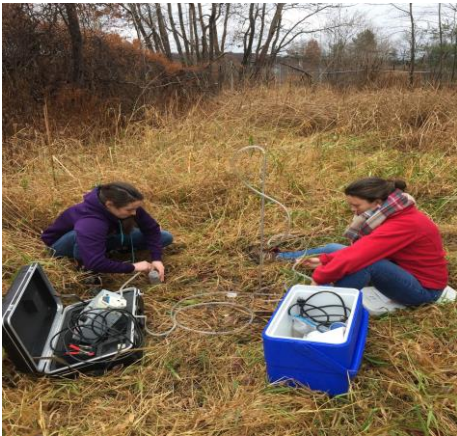

Figure 10: Sampling at Location 4



Figure 11: All Samples

Appendix G: 7 Field Visits 11-29-2016

I-190 Stormwater Field Visit

Date: November 29, 2016 @ 10:00am-6:00pm (8 hours)

Weather: 35-40°F, Drizzling to Rain Storm depending on the time

Attendees: Elizabeth Desjardins, Julia Scott, Anna Valdez, Vincent Vignaly, Steve Sulprizio

Basin 16 – 7: Collecting Runoff Samples

- Upon arrival at the site, Elizabeth, Julia and Vinny took a look at the inlet weir flow setup and made sure excess debris was cleared away and any air gaps underneath the weir were filled
- The wooden weir was still in place from the last storm



Photo 1: Weir Ready for Storm

- The rain gage was emptied before the start of the storm
- Vinny dug a 2 ft hole for a new PVC groundwater well in the first chamber
- The well was constructed using the same process as the wells currently in place



Photo 2: 2' Hole for Groundwater Well

Photo 3: New PVC Groundwater Well

- Steve arrived at site to see the layout of the weir, the groundwater wells and to observe our process for collecting samples
- Rain began at 10:45am but first sample was not taken until 3:07pm when a large enough pool had formed and the water started to flow over the weir
- The rain kept lessening and increasing from 10:45am-2pm and beginning at 2pm a steady rain storm had begun
- 3 samples were taken each time
 - 1 - 1 L bottle for TSS
 - 2 - 250 mL bottle for specific conductance and metals
- Other things noted
 - Height of pond
 - Temperature of water and air was noted
 - Amount of rainwater in gage was noted
- Samples were then taken every half hour
 - 3:38pm, 4:07pm, 4:40pm, 5:08pm and 5:38pm



Photo 4: Waiting for the Pool to Fill



Photo 5: Seconds Before Overflow



Photo 6: Example of Pool Height Measurement

Additionally at 3pm the hydrolab was placed in the pool area in front of the weir

- Around 10am the next morning, 11/30, Vinny picked up the hydrolab



Photo 7: Hydrolab

- Steve arrived around 3pm to take some measurements using his equipment
 - Measured pH, temperature, DO, specific conductance and specific conductance
- Samples were also collected from the Stillwater River at the upstream and downstream locations previously used
 - 2:20pm-2:30pm and 4:10pm - 4:20pm
 - 1 - 1 L bottle for TSS
 - 2 - 250 mL bottle for specific conductance and metals

Appendix G: 8 Field Visit 12-2-2016

I-190 Stormwater Field Visit

Date: December 1, 2016 @ 8:20 am-10:30 am

Weather: 43°F, Sunny

Attendees: Elizabeth Desjardins, Julia Scott, Steve Sulprizio, Anna Valdez

Basin 16 – 7: Groundwater Sampling

- Elizabeth, Julia, and Anna visited the site two mornings after the second sampling storm to observe and take groundwater samples
- The first observation made when arrived at the site was that there was still a small pool of water being restricted by the constructed weir
- The second observation was that all of chamber 1 still had surface water present and there was a small pool of water in the second chamber near the weir with flow entering the second chamber through a crack in the wooden weir separating the chambers
- There had been another storm the night before so the water observed in the basin was likely largely from that storm and not the storm samples



Figure 1: Pool Behind Constructed Weir



Figure 2: Pooling water in Chamber 1 (SouthWest View)



Figure 3: Pooling Water in Chamber 1 (NorthWest View)



Figure 4: Weir between Chambers



Figure 5: Pooling in Chamber 2

- After the team finished observing the site they began taking groundwater samples
- They took samples G13-G15 from the groundwater device in chamber 1 closest to the inlet. The groundwater device was surrounded by surface water
- The team hooked the pump up to the tubing that was already in the groundwater pump and took three flushes and then three samples. Only the three sample bottles were saved, the three flushed were poured out. The flushes were initially kept in case there was not enough water to fill three more bottles.



Figure 6: Sampling at Location 1

- While moving to sample at the second location Steve arrived to observe the groundwater sampling procedure
- At the second location in chamber 1, the newest groundwater device installed, samples G16

- G18 were taken. This groundwater device was also surrounded by surface water. At this location the team stuck a tube down the pvc pipe and hooked the pipe up to the pump. Again they took three flushes and three samples and only kept the samples.



Figure 7: Sampling at Location 2

- The third location, Samples G19-G21, was in the middle of chamber 1, the furthest from the inlet in chamber 1. This location was surrounded by surface water that almost reached the top of the groundwater device. They then proceeded with the same process as location 2.



Figure 8: Sampling at Location 3

- The fourth location, chamber 2, Samples G22-G24 were taken. There was about an inch of surface water surrounding the groundwater device. The same method as in location 2 and 3 was used.



Figure 9: Sampling at Location 4

- For the fifth location the team had to walk on the outside of the fence to get to the groundwater device past the outlet of the basin where samples G25-G27 were taken. This groundwater device was different than the other three and the team had to attach the tubing to the metal rod. Only one flush was able to be taken at this site but the water was visibly clearer.



Figure 10: Sampling at Location 5

All samples were brought back to the lab for testing of TSS, pH, specific conductance, minerals, and metals.

Appendix H: Data Sheets

Appendix H: 1 Field Data Sheet: Surface Water

Sample Key
Runoff Water - R
Ground Water - G
From River - A
Soil - S

Sample Bottles
 TSS samples must be taken in 1L bottles
 Metals can be taken in 250ML bottles

Key
For location please look at the map
- means N/A
X means data will be test for collected

Sample ID	Date	Time	Weather	Location	Temperature	Tests							Notes
						Conductance (µS)	Conductance Data from USGS 01095220	pH	TSS (grams)	Anions	Cations	Digested or Dissolved	
A1	11/02/2016	10:45 AM	Sunny 58°F	Upstream	10°C	282	-	-	X	-	-	Both	Taken from the edge of the bank 1'-2' from the shore. Completely submerged underwater.
A2	11/02/2016	10:45 AM	Sunny 58°F	Upstream	10°C	-	-	-	-	X	X	Both	Taken from the edge of the bank 1'-2' from the shore. Completely submerged underwater.
A3	11/02/2016	10:55 AM	Sunny 58°F	Downstream	9°C	-	-	-	-	X	X	Dissolved	Taken from the edge of the bank 1' from the shore. Completely submerged underwater.
A4	11/02/2016	10:55 AM	Sunny 58°F	Downstream	9°C	398	232	-	X	-	-	Dissolved	Taken from the edge of the bank 1' from the shore. Completely submerged underwater.
A5	11/09/2016	9:33 AM	Overcast 50°F	Downstream	6.5°C	-	-	-	X	-	-	Dissolved	
A6	11/09/2016	9:34 AM	Overcast 50°F	Downstream	6.5°C	-	-	-	X	-	-	Dissolved	
A7	11/09/2016	9:58 AM	Overcast 50°F	Upstream	6.5°C	-	-	-	X	-	-	Dissolved	
A8	11/09/2016	9:58 AM	Overcast 50°F	Upstream	6.5°C	-	-	-	X	-	-	Dissolved	
A9	11/09/2016	9:35 AM	Overcast 50°F	Downstream	6.5°C	414	237	-	-	-	-	Dissolved	
A10	11/09/2016	9:48 AM	Overcast 50°F	Upstream	6.5°C	285	-	-	-	-	-	Dissolved	Water was higher down streams/
A11	11/29/2016	2:21 PM	Rainy 38°F	Down stream	2°C	-	-	-	X	-	-	Dissolved	
A12	11/29/2016	2:21 PM	Rainy 38°F	Downstream		-	-	-	-	X	X	Dissolved	
A13	11/29/2016	2:21 PM	Rainy 38°F	Downstream	1°C	336	-	5.54	-	-	-	Dissolved	
A14	11/29/2016	2:28 PM	Rainy 38°F	Upstream		-	-	-	-	X	X	Dissolved	
A15	11/29/2016	2:28 PM	Rainy 38°F	Upstream	1°C	213	-	5.31	-	-	-	Dissolved	
A16	11/29/2016	2:28 PM	Rainy 38°F	Upstream		-	-	-	X	-	-	Dissolved	
A17	11/29/2016	4:13 PM	Rainy 40°F	Upstream	1°C	-	-	-	X	-	-	Dissolved	
A18	11/29/2016	4:13 PM	Rainy 40°F	Upstream		-	-	-	-	X	X	Dissolved	
A19	11/29/2016	4:13 PM	Rainy 40°F	Upstream		212	-	5.41	-	-	-	Dissolved	
A20	11/29/2016	4:20 PM	Rainy 40°F	Downstream	2°C	-	-	-	X	-	-	Dissolved	
A21	11/29/2016	4:20 PM	Rainy 40°F	Downstream		-	-	-	-	X	X	Dissolved	
A22	11/29/2016	4:20 PM	Rainy 40°F	Downstream		326	-	5.91	-	-	-	Dissolved	

A23	12/01/2016	9:45 AM	Sunny 44	Inlet	-	-	-	-	X	-	-	Dissolved	
A24	12/01/2016	9:45 AM	Sunny 44	Inlet		180.4	-	X	-	-	-	Dissolved	
A25	12/01/2016	9:45 AM	Sunny 44	Inlet		-	-	-	-	X	X	Dissolved	
A26	11/30/2016	3:45 PM	-	Mathisen	-	689	-	6.16	-	-	-	Dissolved	
A27	11/30/2016	3:45 PM	-	Mathisen		537	-	6.3	-	-	-	Dissolved	
A28	11/30/2016	3:50 PM	-	Mathisen		218	-	5.7	-	-	-	Dissolved	

Appendix H: 2 Field Data Sheet: Runoff

Sample Key
Runoff Water = R
Ground Water = G
From River = A
Soil = S

Sample Bottles
 TSS samples must be taken in 1L bottles
 Metals can be taken in 250ML bottles

Key
For location please look at the map
- means N/A
X means data will be test for collected

Sample ID	Date	Time	Weather	Location	Temperature	Teels						Notes
						Conductance (µS)	pH	TSS (grams)	Anions	Cations	Digested or Dissolved	
R1	11/15/2016	2:15 PM	Rainy 45°F	L3	4°C	-	-	X	-	-	Both	Precipitation gauge reading: 4mm Height of H2O: 0.12 ft
R2	11/15/2016	2:15 PM	Rainy 45°F	L3	4°C	122.4	-	-	-	-	Both	
R3	11/15/2016	2:15 PM	Rainy 45°F	L3	4°C	-	-	-	X	X	Both	Precipitation gauge reading: 6mm Height of H2O: 0.37 ft
R4	11/15/2016	2:46 PM	Rainy 45°F	L3	4°C	-	-	X	-	-	Both	
R5	11/15/2016	2:46 PM	Rainy 45°F	L3	4°C	413	-	-	-	-	Both	Precipitation gauge reading: 10mm Height of H2O: 0.39 ft
R6	11/15/2016	2:46 PM	Rainy 45°F	L3	4°C	-	-	-	X	X	Both	
R7	11/15/2016	3:17 PM	Rainy 45°F	L3	4°C	-	-	X	-	-	Both	Precipitation gauge reading: 12mm Height of H2O: 0.44 ft
R8	11/15/2016	3:17 PM	Rainy 45°F	L3	4°C	306	-	-	-	-	Both	
R9	11/15/2016	3:17 PM	Rainy 45°F	L3	4°C	-	-	-	X	X	Both	Precipitation gauge reading: 16mm Height of H2O: 0.44 ft
R10	11/15/2016	3:50 PM	Rainy 45°F	L3	4°C	-	-	X	-	-	Both	
R11	11/15/2016	3:50 PM	Rainy 45°F	L3	4°C	245	-	-	-	-	Both	Precipitation gauge reading: 19 mm Height of H2O: 0.41 ft
R12	11/15/2016	3:50 PM	Rainy 45°F	L3	4°C	-	-	-	X	X	Both	
R13	11/15/2016	4:50 PM	Rainy 45°F	L3	4°C	-	-	X	-	-	Both	Chamber 1 filled with 4" of water. 3" - 4.5" of water found in other location depending on water.
R14	11/15/2016	4:50 PM	Rainy 45°F	L3	4°C	150.6	-	-	-	-	Both	
R15	11/15/2016	4:50 PM	Rainy 45°F	L3	4°C	-	-	-	X	X	Both	Chamber 2: 3" of water pooled on concrete near wooden weir.
R16	11/15/2016	4:15 PM	Rainy 45°F	L3	4°C	-	-	X	-	-	Both	
R17	11/15/2016	4:15 PM	Rainy 45°F	L3	4°C	174.6	-	-	-	-	Both	Precipitation gauge reading: 0.2in Height of H2O: 0.35 ft
R18	11/15/2016	4:15 PM	Rainy 45°F	L3	4°C	-	-	-	X	X	Both	
R19	11/15/2016	4:35 PM	Rainy 45°F	I6	4°C	-	-	-	X	X	Both	Precipitation gauge reading: 0.3in Height of H2O: 0.39 ft
R20	11/15/2016	4:35 PM	Rainy 45°F	H8	4°C	-	-	-	X	X	Both	
R21	11/29/2016	3:07 PM	Rainy 38°F	L3	1°C	-	-	X	-	-	Dissolved	Precipitation gauge reading: 0.3in Height of H2O: 0.39 ft
R22	11/29/2016	3:07 PM	Rainy 38°F	L3	1°C	-	-	-	X	X	Dissolved	
R23	11/29/2016	3:07 PM	Rainy 38°F	L3	1°C	2.57 ms	6.27	-	-	-	Dissolved	Precipitation gauge reading: 0.6in Height of H2O: 0.42 ft
R24	11/29/2016	3:38 PM	Rainy 38°F	L3	1°C	-	-	X	-	-	Dissolved	
R25	11/29/2016	3:38 PM	Rainy 38°F	L3	1°C	-	-	-	X	X	Dissolved	

R24	11/29/2016	3:38 PM	Rainy 38°F	L3	1°C	-	-	X	-	-	Dissolved	Precipitation gauge reading: 0.3in Height of H2O: 0.39 ft
R25	11/29/2016	3:38 PM	Rainy 38°F	L3	1°C	-	-	-	X	X	Dissolved	
R26	11/29/2016	3:38 PM	Rainy 38°F	L3	1°C	1554	6.3	-	-	-	Dissolved	Precipitation gauge reading: 0.3in Height of H2O: 0.39 ft
R27	11/29/2016	4:07 PM	Rainy 38°F	L3	1°C	-	-	X	-	-	Dissolved	
R28	11/29/2016	4:07 PM	Rainy 38°F	L3	1°C	-	-	-	X	X	Dissolved	Precipitation gauge reading: 0.4in Height of H2O: 0.39 ft
R29	11/29/2016	4:07 PM	Rainy 38°F	L3	1°C	953	6.32	-	-	-	Dissolved	
R30	11/29/2016	4:40 PM	Rainy 40°F	L3	1°C	-	-	X	-	-	Dissolved	Precipitation gauge reading: 0.5in Height of H2O: 0.40 ft
R31	11/29/2016	4:40 PM	Rainy 40°F	L3	1°C	-	-	-	X	X	Dissolved	
R32	11/29/2016	4:40 PM	Rainy 40°F	L3	1°C	949	6.42	-	-	-	Dissolved	Precipitation gauge reading: 0.6in Height of H2O: 0.42 ft
R33	11/29/2016	5:08 PM	Rainy 40°F	L3	1°C	-	-	-	X	X	Dissolved	
R34	11/29/2016	5:08 PM	Rainy 40°F	L3	1°C	760	6.17	-	-	-	Dissolved	Precipitation gauge reading: 0.6in Height of H2O: 0.42 ft
R35	11/29/2016	5:08 PM	Rainy 40°F	L3	1°C	-	-	X	-	-	Dissolved	
R36	11/29/2016	5:38 PM	Rainy 40°F	L3	1°C	-	-	X	-	-	Dissolved	Precipitation gauge reading: 0.6in Height of H2O: 0.42 ft
R37	11/29/2016	5:38 PM	Rainy 40°F	L3	1°C	-	-	-	X	X	Dissolved	
R38	11/29/2016	5:38 PM	Rainy 40°F	L3	1°C	570	6.19	-	-	-	Dissolved	

Appendix H: 3 Field Data Sheet: Groundwater

Sample Key
Runoff Water = R
Ground Water = G
From River = A
Soil = S

Sample Bottles
 TSS samples must be taken in 1L bottles
 Metals can be taken in 250ML bottles

Key
For location please look at the map
- means N/A
X means data will be test for collected

Graph #	Location from Map
1	J5
2	K6
3	K8
4	H8
5	I16+

Sample ID	Date	Time	Weather	Location	Tests						Notes
					Conductance (µS) micro(µ) or milli(m)	pH	TSS (grams)	Anions	Cations	Digested or Dissolved	
G1	11/16/2016	4:15 PM	Overcast 50°F	J5	-	-	X	-	-	Both	Sample was too high in Fe and Al to test for minerals
G2	11/16/2016	4:15 PM	Overcast 50°F	J5	364	-	-	-	-	Both	
G3	11/16/2016	4:15 PM	Overcast 50°F	J5	-	-	-	X	X	Both	
G4	11/16/2016	4:15 PM	Overcast 50°F	H8	-	-	X	-	-	Both	Sample was too high in Fe and Al to test for minerals
G5	11/16/2016	4:15 PM	Overcast 50°F	H8	175	-	-	-	-	Both	
G6	11/16/2016	4:15 PM	Overcast 50°F	H8	-	-	-	X	X	Both	
G7	11/16/2016	4:15 PM	Overcast 50°F	K7	-	-	X	-	-	Both	Sample was too high in Fe and Al to test for minerals
G8	11/16/2016	4:15 PM	Overcast 50°F	K7	431	-	-	-	-	Both	
G9	11/16/2016	4:15 PM	Overcast 50°F	K7	-	-	-	X	X	Both	
G10	11/16/2016	4:15 PM	Overcast 50°F	I16+	-	-	X	-	-	Both	No Standing Water
G11	11/16/2016	4:15 PM	Overcast 50°F	I16+	3.42	-	-	-	-	Both	
G12	11/16/2016	4:15 PM	Overcast 50°F	I16+	-	-	-	X	X	Both	
G13	12/01/2016	8:38 AM	Sunny 44	J5	-	-	X	-	-	Dissolved	4" of sitting water near rock weir it was 8" deep
G14	12/01/2016	8:38 AM	Sunny 44	J5	666	5.92	-	-	-	Dissolved	
G15	12/01/2016	8:38 AM	Sunny 44	J5	-	-	-	X	X	Dissolved	
G16	12/01/2016	8:47 AM	Sunny 44	K6	-	-	X	-	-	Dissolved	10" by rock weir , 9.5" of water by weir
G17	12/01/2016	8:47 AM	Sunny 44	K6	677	5.5	-	-	-	Dissolved	
G18	12/01/2016	8:47 AM	Sunny 44	K6	-	-	-	X	X	Dissolved	
G19	12/01/2016	8:57 AM	Sunny 44	K8	-	-	X	-	-	Dissolved	9" of water by weir, 12.25" of water
G20	12/01/2016	8:57 AM	Sunny 44	K8	604	5.79	-	-	-	Dissolved	
G21	12/01/2016	8:57 AM	Sunny 44	K8	-	-	-	X	X	Dissolved	
G22	12/01/2016	9:08 AM	Sunny 44	H8	-	-	X	-	-	Dissolved	1" by the device - 3" by the weir. In grey bag
G23	12/01/2016	9:08 AM	Sunny 44	H8	138.7	6.17	-	-	-	Dissolved	
G24	12/01/2016	9:09 AM	Sunny 44	H8	-	-	-	X	X	Dissolved	
G25	12/01/2016	9:20 AM	Sunny 44	I16+	-	-	X	-	-	Dissolved	2.25" standing water. 2" by it. In yellow bag
G26	12/01/2016	9:08 AM	Sunny 44	I16+	3.38ms	6.02	-	-	-	Dissolved	
G27	12/01/2016	9:00 AM	Sunny 44	I16+	-	-	-	X	X	Dissolved	

Appendix H: 4 Field Data Sheet: Soil

Sample Key
Runoff Water = R
Ground Water = G
From River = A
Soil = S

Sample Bottles
 TSS samples must be taken in 1L bottles
 Metals can be taken in 250ML

Key
For location please look at the map
- means N/A
X means data will be test for collected

Graph #	Location from Map
A	2S
B	5S
C	1S
D	3S
E	4S
F	6S

Sample ID	Date	Time	Weather	Location						Notes
					Anions	Cations	Digested or Dissolved	Distance from Edge	Deep	
1S	11/02/2016	8:35 AM	Sunny 52°F	J5	X	X	Digested	18.9' from inlet 15.8' to wall	1' - 18"	Taken at where groundwater gage was placed. Took lower soil, all light soil, high moisture content, more sandy than others.
2S	11/02/2016	8:45 AM	Sunny 52°F	K4	X	X	Digested	8.5' from inlet 15.8' to wall	6"	Taken at build up, all sediment
3S	11/02/2016	9:02 AM	Sunny 52°F	K9	X	X	Digested	97.5' from inlet 17.8' to wall	6"	1.5" sediments to soil (rocky) (sample sediment and lower level)
4S	11/02/2016	9:30 AM	Sunny 52°F	H8	X	X	Digested	76" to inlet 7.5' to weir	4.5"	sandy, moist (drier than other soils) @ 1'4" no change in soil type
5S	11/02/2016	9:35 AM	Sunny 52°F	K5	X	X	Digested	16.7' to inlet 22.4' to weir	11"	11" of top sediments
6S	11/02/2016	9:51 AM	Sunny 52°F	D2	X	X	Digested	27" to rocks 35" to weir	1' 1.5"	9" of sediment before we hit sand.

Appendix H: 5 Lab Data: Digested Metals

Will be larger in final

Sample ID	Al 27 (ppb)	V 51 (ppb)	Cr-1 52 (ppb)	Mn 55 (ppb)	Fe-1 57 (ppb)	Co 59 (ppb)	Ni 61 (ppb)	Cu 63 (ppb)	Zn 66 (ppb)	As 75 (ppb)	Cd 111 (ppb)	Pb 208 (ppb)
2A	100.369	0.619	0.186	56.888	224.577	0.225	3.323	3.053	10.112	1.441	0.532	0.22
3A	74.313	0.76	0.182	122.339	305.419	0.279	3.639	4.437	8.437	2.305	0.029	0.189
Sample ID	Al 27 (ppm)	V 51 (ppm)	Cr-1 52 (ppm)	Mn 55 (ppm)	Fe-1 57 (ppb)	Co 59 (ppm)	Ni 61 (ppm)	Cu 63 (ppm)	Zn 66 (ppm)	As 75 (ppm)	Cd 111 (ppm)	Pb 208 (ppm)
S-1	16503.6793	25.0065	59.1065	409.2129	-	14.1462	41.1002	33.5949	119.9126	83.8742	0.3914	48.6510
S-2	9945.2482	21.1174	46.0018	483.0000	-	10.2988	25.9277	72.1004	440.9404	7.9869	0.4590	88.1155
S-3	15449.4029	20.7151	50.8473	345.5568	-	10.3841	32.5387	35.0827	141.3917	35.9774	0.1322	42.0961
S-4	3934.0192	-6.1398	10.1736	147.0739	-	4.3774	8.3753	9.9975	62.8828	-7.9803	0.0921	16.5861
S-5	8991.9434	10.3179	37.5679	374.8601	-	7.7652	17.2966	60.8086	258.6533	1.0444	0.2029	126.2656
S-6	5505.8967	-6.0120	8.6781	98.5000	-	2.6196	6.3122	5.4286	22.4999	-7.6657	0.0614	5.3439
Sample ID	Al 27 (ppm)	V 51 (ppm)	Cr-1 52 (ppm)	Mn 55 (ppm)	Fe-1 57 (ppb)	Co 59 (ppm)	Ni 61 (ppm)	Cu 63 (ppm)	Zn 66 (ppm)	As 75 (ppm)	Cd 111 (ppm)	Pb 208 (ppm)
R3	481.0070	3.9934	2.3058	17.0022	700.6901	0.7520	4.7117	16.0561	34.2918	1.9732	0.0378	2.6727
R6	4967.9115	35.1481	33.9723	254.6597	9301.3003	7.1423	24.4823	77.0718	279.6146	13.2197	0.2487	23.5596
R9	2901.8968	19.9184	23.7186	133.0818	5337.2670	3.9308	12.2616	51.7059	150.8103	7.6475	0.1495	13.9007
R12	3619.9699	23.5590	29.1510	178.5555	7114.1150	5.2504	14.3574	57.9570	193.7502	9.9039	0.1627	19.5125
R15	3711.2370	24.3849	29.3168	182.0192	7174.0697	5.3405	15.1271	59.0505	197.1603	10.0617	0.1607	19.5617
R18	2502.2737	17.1741	25.3357	122.6847	4797.0452	3.4840	9.7816	39.4322	123.3519	6.9968	0.0978	12.8064
R19	1672.0208	10.9371	20.5440	83.5710	3174.1465	2.4078	6.9032	31.7930	87.6663	5.3202	0.0681	9.8234
R20	1537.7925	9.1842	15.8199	77.2139	2840.3905	3.1718	8.9873	36.9252	84.7226	8.3338	0.0756	9.3800
Sample ID	Al 27 (ppm)	V 51 (ppm)	Cr-1 52 (ppm)	Mn 55 (ppm)	Fe-1 57 (ppb)	Co 59 (ppm)	Ni 61 (ppm)	Cu 63 (ppm)	Zn 66 (ppm)	As 75 (ppm)	Cd 111 (ppm)	Pb 208 (ppm)
G3	7428.7345	15.8330	20.8676	210.4780	7028.8969	7.3085	20.5542	80.2472	128.1029	50.1393	0.1612	42.6371
G6	696.1010	2.9687	11.9052	26.7106	1034.2983	1.1370	4.6812	20.8466	25.9052	3.3497	0.0316	4.3969
G9	S	30.1749	32.5014	650.0902	16153.6401	26.1207	39.2113	87.6191	120.1399	120.8813	0.1483	61.5012
G12	1169.5936	4.1176	1.9456	24.0799	705.5293	0.6899	9.9033	50.5683	4.4989	3.6421	0.0163	0.7600

Appendix H: 6 Lab Data: Digested Minerals

Sample ID	Na 23 (ppb)	Mg 24 (ppb)	K 39 (ppb)	Ca 43 (ppb)	Ca-1 43 (ppb)
R3	14510.793	701.849	2453.454	494.535	2033.210
R6	40726.247	4050.936	4330.152	968.465	4106.977
R9	32143.475	2357.346	3380.877	688.228	2645.321
R12	25792.530	2734.084	2732.529	420.354	2036.217
R15	25439.518	2678.544	2756.120	511.019	1989.743
R18	19918.550	1859.860	2475.840	403.870	1453.115
R19	18512.121	1289.024	2045.958	280.236	1024.213
R20	27296.326	1185.695	2993.410	255.509	1212.010

Sample ID	Na 23 (ppb)	Mg 24 (ppb)	K 39 (ppb)	Ca 43 (ppb)	Ca-1 43 (ppb)
2A	22394.992	1447.138	2321.147	785.233	3647.195
3A	30561.521	1769.862	2242.599	1153.814	5048.101

Sample ID	Na 23 (ppm)	Mg 24 (ppm)	K 39 (ppm)	Ca 43 (ppm)	Ca-1 43 (ppm)
S-1	713.522	9412.721	3827.812	187.710	842.594
S-2	436.850	5720.160	1627.282	348.641	1543.939
S-3	992.685	7647.496	3208.630	253.527	1220.642
S-4	266.297	1616.710	950.626	119.210	544.457
S-5	1185.784	4069.133	1105.085	230.548	1051.926
S-6	159.001	1596.197	1312.619	129.549	615.693

Sample ID	Na 23 (ppm)	Mg 24 (ppm)	K 39 (ppm)	Ca 43 (ppm)	Ca-1 43 (ppm)
G3	51787.513	2030.852	2222.542	300.842	901.751
G6	23162.758	334.119	2781.317	222.540	705.486
G9	56179.775	3805.933	4513.360	304.963	1117.428
G12	368376.796	7290.459	7526.249	4838.259	18131.009

Appendix H: 7 Lab Data: Dissolved Metals

Sample ID	A1 27 (ppb)	V 51 (ppb)	Cr-1 52 (ppb)	Mn 55 (ppb)	Fe-1 57 (ppb)	Co 59 (ppb)	Ni 61 (ppb)	Cu 63 (ppb)	Zn 66 (ppb)	As 75 (ppb)	Cd 111 (ppb)	Pb 208 (ppb)
A2	55.621	0.308	0.101	36.996	117.153	0.133	1.973	1.737	8.06	1.157	0.441	0.078
A3	34.514	0.474	0.074	79.524	127.602	0.168	2.309	2.677	4.267	1.714	0.022	0.053
A12	33.564	0.397	0.067	56.483	86.063	0.148	2.021	1.920	2.926	1.364	0.009	0.049
A14	44.741	0.277	0.054	25.459	74.701	0.114	1.496	1.121	3.318	0.835	0.021	0.062
A18	44.024	0.298	0.068	25.254	74.071	0.113	1.414	2.131	3.854	0.803	0.120	0.081
A21	31.290	0.448	0.059	50.805	90.985	0.133	1.859	2.182	2.485	1.200	0.006	0.055
A-25	133.293	0.682	1.693	1.07	103.737	0.052	0.822	8.37	4.004	1.048	0	0.698
A26	139.554	1.356	2.551	4.667	159.459	0.092	1.998	23.188	13.177	2.126	0.019	0.875
A-27	92.872	1.298	4.169	2.688	107.385	0.057	1.664	23.501	14.555	1.588	0.149	0.542
A-28	69.058	0.406	0.109	12.616	101.669	0.063	2.246	4.327	6.423	1.282	0.006	0.058

Sample ID	A1 27 (ppb)	V 51 (ppb)	Cr-1 52 (ppb)	Mn 55 (ppb)	Fe-1 57 (ppb)	Co 59 (ppb)	Ni 61 (ppb)	Cu 63 (ppb)	Zn 66 (ppb)	As 75 (ppb)	Cd 111 (ppb)	Pb 208 (ppb)
R3	59.991	1.841	0.473	0.609	39.790	0.104	1.488	8.163	6.102	1.328	0.007	0.182
R6	150.687	3.752	9.714	10.529	180.326	0.251	2.170	13.081	11.896	2.348	0.015	0.516
R9	134.086	2.559	10.045	7.694	170.026	0.211	1.642	13.315	11.803	1.870	0.014	0.515
R12	115.930	2.629	10.947	6.894	144.065	0.165	0.934	9.256	7.815	2.022	0.009	0.445
R15	100.279	2.004	11.890	5.749	117.117	0.123	0.561	6.746	5.965	1.638	0.004	0.374
R18	108.654	2.376	13.490	5.706	129.014	0.131	0.605	7.524	6.113	1.773	0.005	0.407
R19	114.358	2.041	12.489	4.696	145.130	0.131	0.554	8.760	6.452	1.733	0.006	0.558
R20	192.646	1.764	8.893	7.812	246.744	0.696	2.704	15.325	11.268	4.436	0.022	0.862
R22	72.412	3.463	4.356	11.576	88.887	0.221	5.431	37.439	17.278	2.764	0.028	0.212
R25	65.695	2.629	5.923	10.725	77.960	0.182	3.541	33.479	14.273	1.981	0.024	0.189
R28	66.860	2.068	6.948	7.994	83.310	0.145	2.328	24.783	13.317	1.523	0.019	0.230
R31	79.049	2.440	8.794	8.473	90.975	0.154	1.965	26.804	12.125	1.748	0.014	0.231
R33	85.124	2.150	9.976	7.814	91.172	0.141	1.479	22.395	10.998	1.508	0.015	0.236
R37	69.300	1.767	11.975	6.443	81.762	0.130	1.206	16.783	9.576	1.370	0.019	0.213

Sample ID	A1 27 (ppb)	V 51 (ppb)	Cr-1 52 (ppb)	Mn 55 (ppb)	Fe-1 57 (ppb)	Co 59 (ppb)	Ni 61 (ppb)	Cu 63 (ppb)	Zn 66 (ppb)	As 75 (ppb)	Cd 111 (ppb)	Pb 208 (ppb)
G3	3166.254	6.934	13.069	68.926	3543.193	2.161	6.964	50.714	60.985	26.524	0.068	20.612
G6	233.416	1.231	9.650	5.027	259.145	0.321	1.320	11.987	7.881	2.083	0.018	1.237
G9	4711.083	7.661	10.710	149.809	5506.725	6.853	11.544	49.163	79.259	49.660	0.053	22.454
G12	7.336	2.731	0.069	13.032	11.273	0.252	6.057	37.092	1.249	2.624	0.014	0.021
G-15	1066.279	3.119	4.953	27.440	1018.808	0.748	4.484	45.426	17.534	6.551	0.084	6.179
G-18	1082.548	1.959	1.853	60.674	899.231	1.620	3.449	23.474	8.048	8.129	0.036	4.630
G-21	714.920	1.556	3.459	16.385	1084.513	0.780	2.304	19.860	5.052	7.521	0.000	3.308
G-24	126.214	1.094	4.625	1.197	91.597	0.067	0.959	9.090	0.361	1.834	0.000	0.288
G-27	2.664	1.574	0.096	7.636	8.632	0.157	4.351	62.543	-1.835	2.072	0.000	0.000

Appendix H: 8 Lab Data: Dissolved Minerals

Sample ID	Na 23 (ppb)	Mg 24 (ppb)	K 39 (ppb)	Ca 43 (ppb)	Ca-1 43 (ppb)
A2	21398.247	1366.253	1679.396	636.837	2834.866
A3	31764.093	1824.449	1901.095	1026.128	4633.227
A12	25986.477	1407.992	2055.581	1086.443	3748.672
A14	16210.027	1091.985	1554.599	680.063	2619.519
A18	16421.306	1030.663	1546.166	688.356	2626.757
A21	26465.417	1327.540	1965.978	974.481	3489.826
A26	81071.377	1056.570	3007.727	414.822	1760.968
A-27	59489.538	712.417	1750.309	288.071	1425.085
A-28	17035.787	1089.681	1337.648	725.939	2864.300
A-25	21060.006	178.426	969.828	146.916	713.927

Sample ID	Na 23 (ppb)	Mg 24 (ppb)	K 39 (ppb)	Ca 43 (ppb)	Ca-1 43 (ppb)
R3	12803.282	419.625	1977.342	334.185	1585.711
R6	41120.256	1103.062	4672.709	836.845	3666.912
R9	28950.144	591.187	2578.431	361.803	1814.525
R12	23831.075	406.122	1775.921	231.996	1097.575
R15	15348.601	237.300	1300.045	110.474	596.184
R18	17308.233	272.771	1472.895	140.855	686.581
R19	16526.459	256.050	1399.995	102.189	499.730
R20	24206.208	268.013	2050.505	71.808	283.526
R22	268440.536	3241.107	4737.759	2695.386	10823.638
R25	163455.274	2658.667	3762.289	1890.912	6990.511
R28	97243.844	1568.718	2856.076	941.307	4240.612
R31	102916.912	1097.502	2622.500	642.742	2766.303
R33	84207.439	816.639	2287.645	385.645	1875.204
R37	62761.191	615.864	2048.849	410.525	1539.973

Sample ID	Na 23 (ppb)	Mg 24 (ppb)	K 39 (ppb)	Ca 43 (ppb)	Ca-1 43 (ppb)
G3	44557.859	691.525	1424.521	74.570	245.319
G6	20731.454	39.665	2093.159	-13.809	-62.435
G9	52253.067	847.008	2926.104	77.332	402.344
G12	3739.413	65.702	63.174	38.418	180.175
G-15	82444.361	432.509	1087.536	164.200	674.929
G-18	76289.130	358.027	1330.053	224.695	915.071
G-21	67522.309	289.560	1985.241	109.467	531.688
G-24	16458.991	31.030	1194.707	57.614	203.071
G-27	364669.419	5987.403	5853.236	4110.833	17124.468

Appendix I: Graphs

Appendix I: 1 Soil

Figure 73 is of the soil samples taken at 5 locations throughout the basin and a control (F). The samples were tested for digested minerals and metals. The highest contaminants present are Al and Mg at C and D.

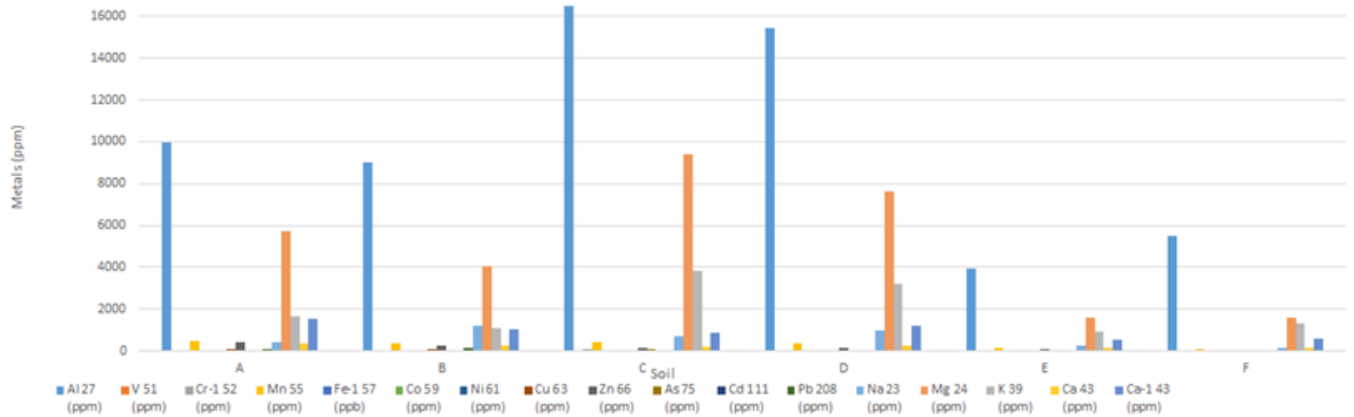

FIGURE 73: SOILS TESTED FOR DIGESTED METALS

Figure 74 is the same as Figure 74 except it excludes data of Al and Mg. The highest contaminants present are K, Ca-1 and Na.

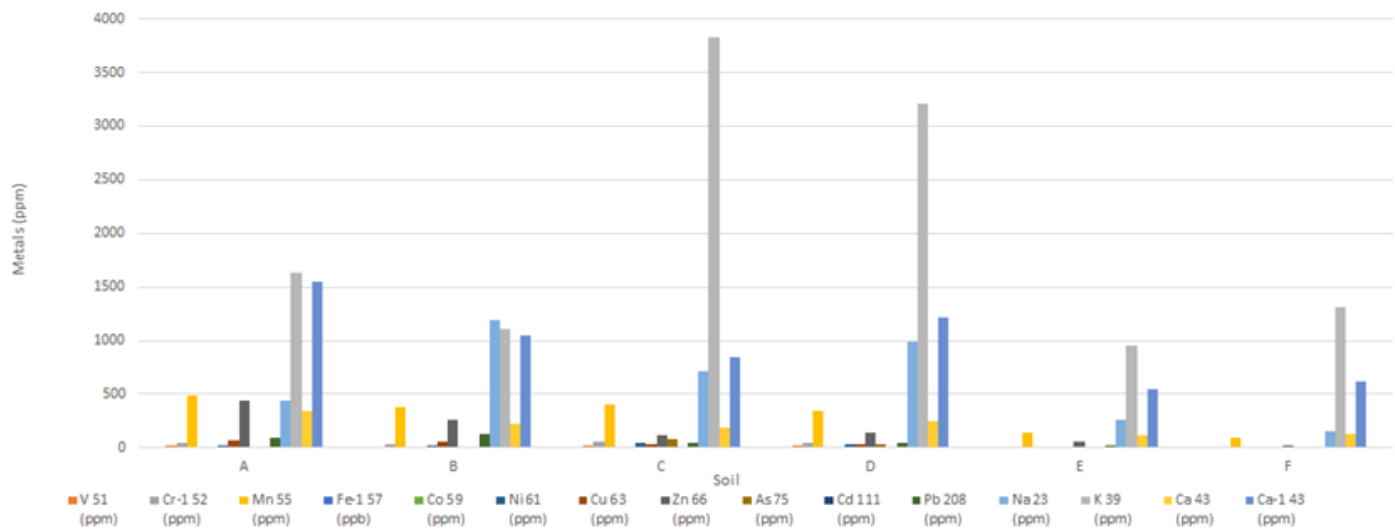

FIGURE 74: SOILS TESTED FOR DIGESTED METALS W/O AL AND MG

Appendix I: 2 Runoff

Figure 75 shows the correlation between pH and Specific Conductance from Storm 2 runoff samples. The pH has a nonlinear spike to it at 4:40pm which could be a bad reading or represents a sudden change in water quality.

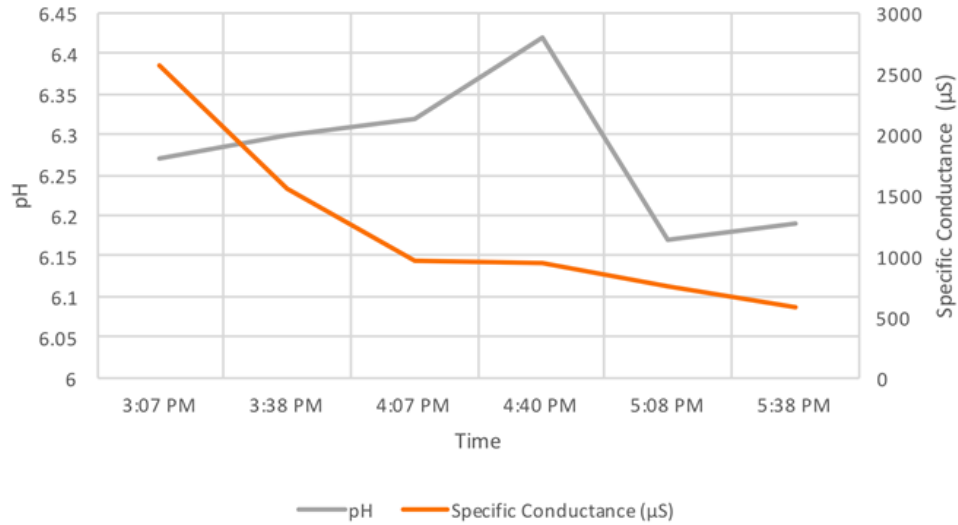

FIGURE 75: RUNOFF TESTED FOR PH VS. SPECIFIC CONDUCTANCE FOR STORM 2

Figure 76 shows the correlation between the levels of metals and the specific conductance. As the metals concentrations increase or decrease so do the specific conductance levels.

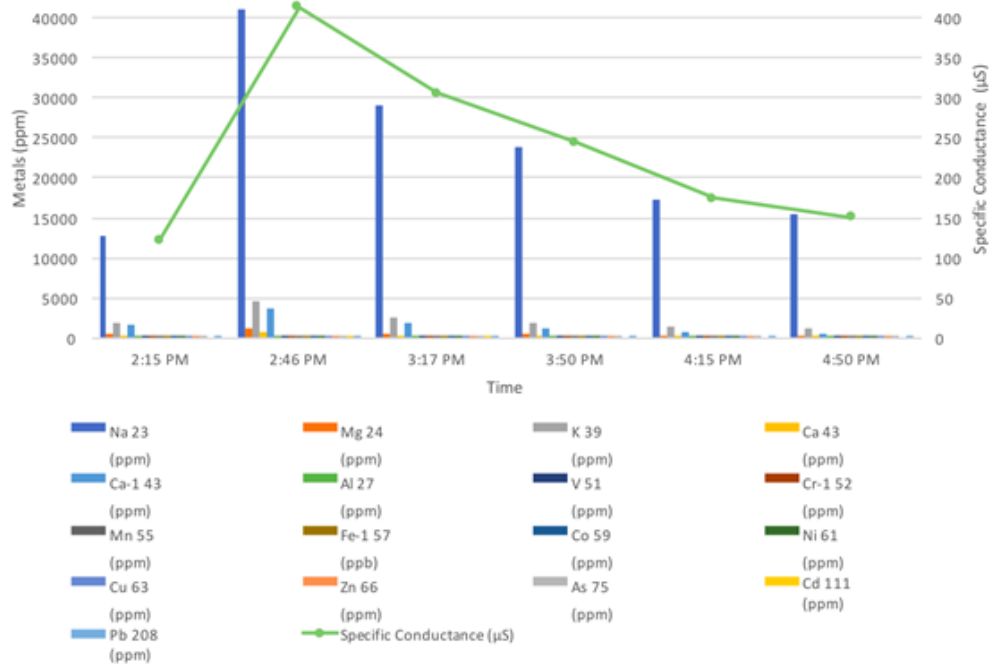

FIGURE 76: RUNOFF TESTED FOR DISSOLVED METALS WITH SPECIFIC CONDUCTANCE FOR STORM 1

Figure 77 shows the correlation between pH levels and the dissolved metals found in Storm 2 runoff samples. The pH has a large peak at 4:40pm which matches a small increase in Na.

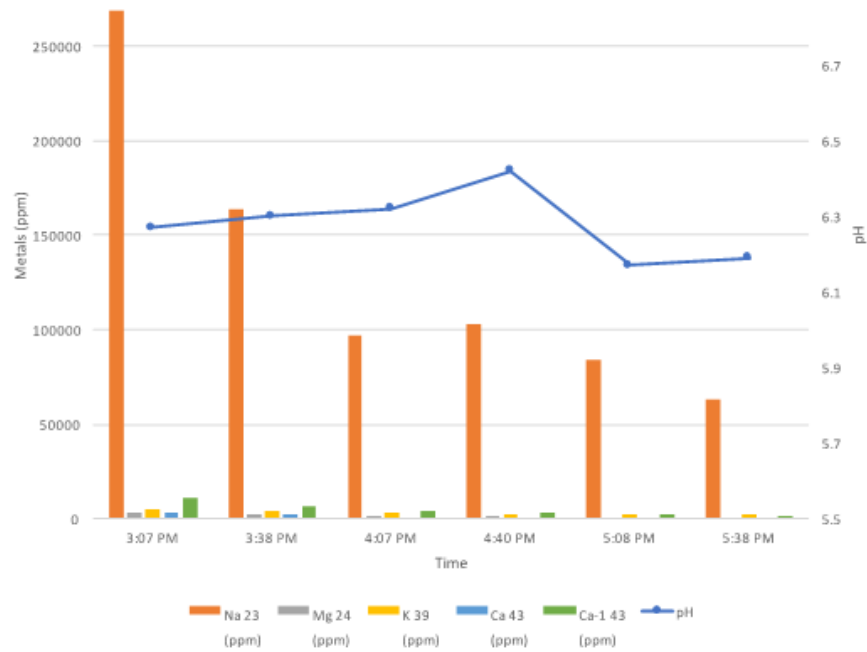

FIGURE 77: RUNOFF TESTED FOR DISSOLVED METALS WITH PH FOR STORM 2

Figure 78 shows the total precipitation during Storm 1 with the decreasing levels of dissolved metals. The concentration of metals decrease after the first flush at 2:46pm.

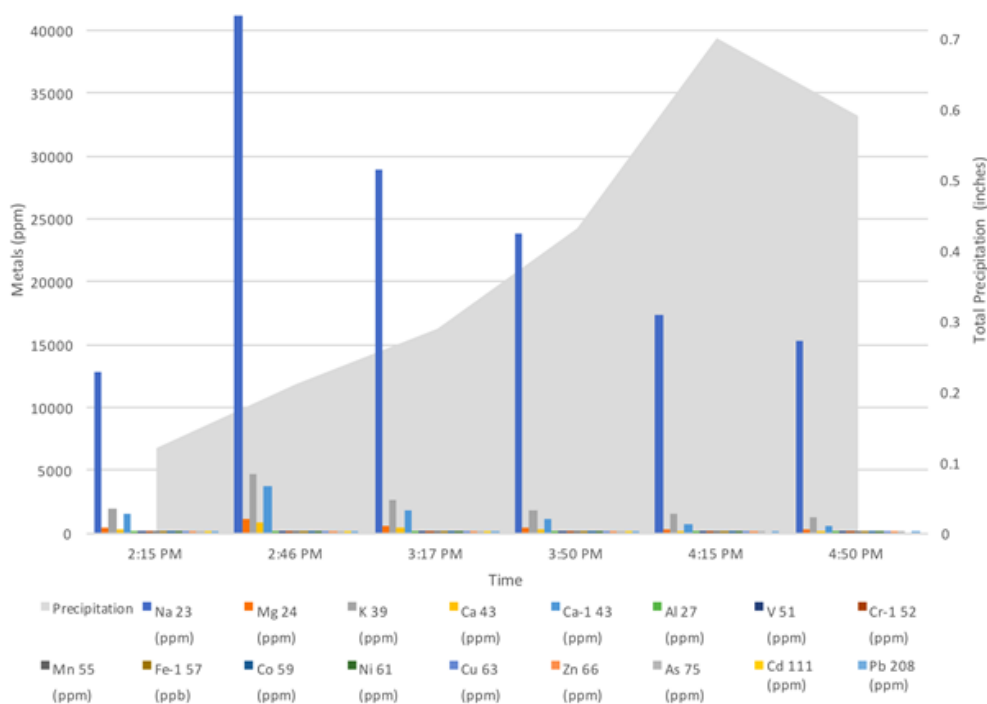

FIGURE 78: RUNOFF DISSOLVE METALS WITH TOTAL PRECIPITATION FROM STORM 1

Figure 79 shows the total precipitation during Storm 1 with the decreasing levels of dissolved metals, however it leaves out Na. By leaving out Na you can see how the other metals similarly decrease after the first flush at 2:46pm.

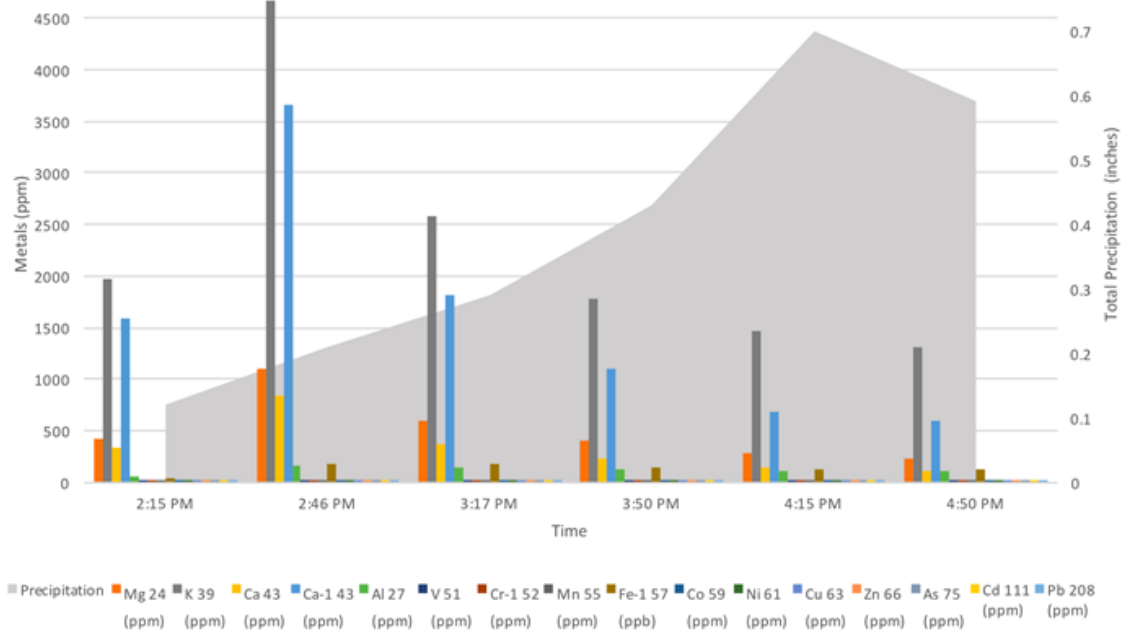

FIGURE 79: RUNOFF METALS W/OUT NA WITH TOTAL PRECIPITATION FROM STORM 1

Figure 80 shows the total precipitation during Storm 2 with the decreasing levels of dissolved metals. As the total amount of precipitation increases the amount of metals in the samples decreases.

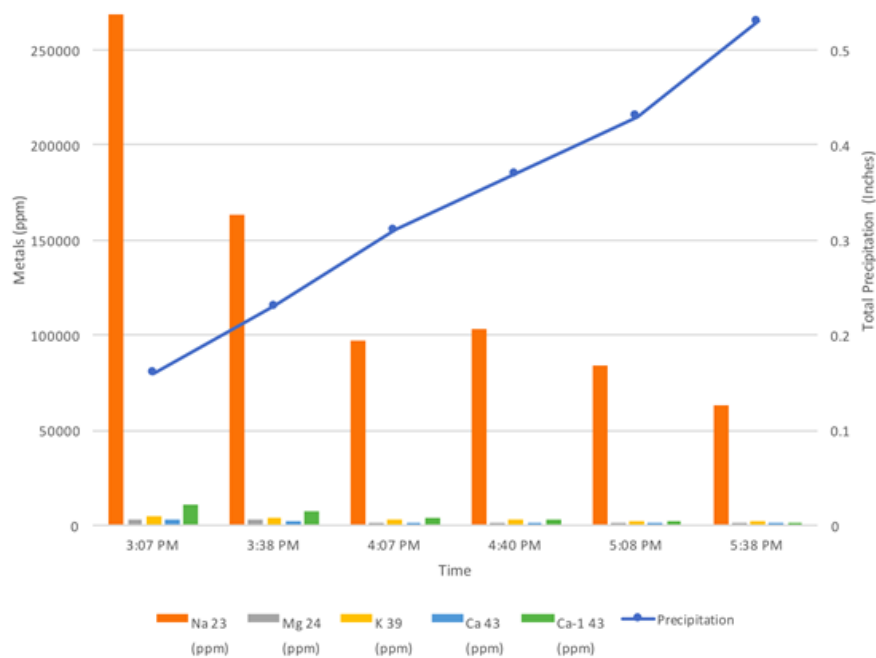

FIGURE 80: RUNOFF DISSOLVED METALS WITH CUMULATIVE PRECIPITATION FROM STORM 2

Figure 81 shows the decrease in metal concentrations without Na as the total precipitation increased over time.

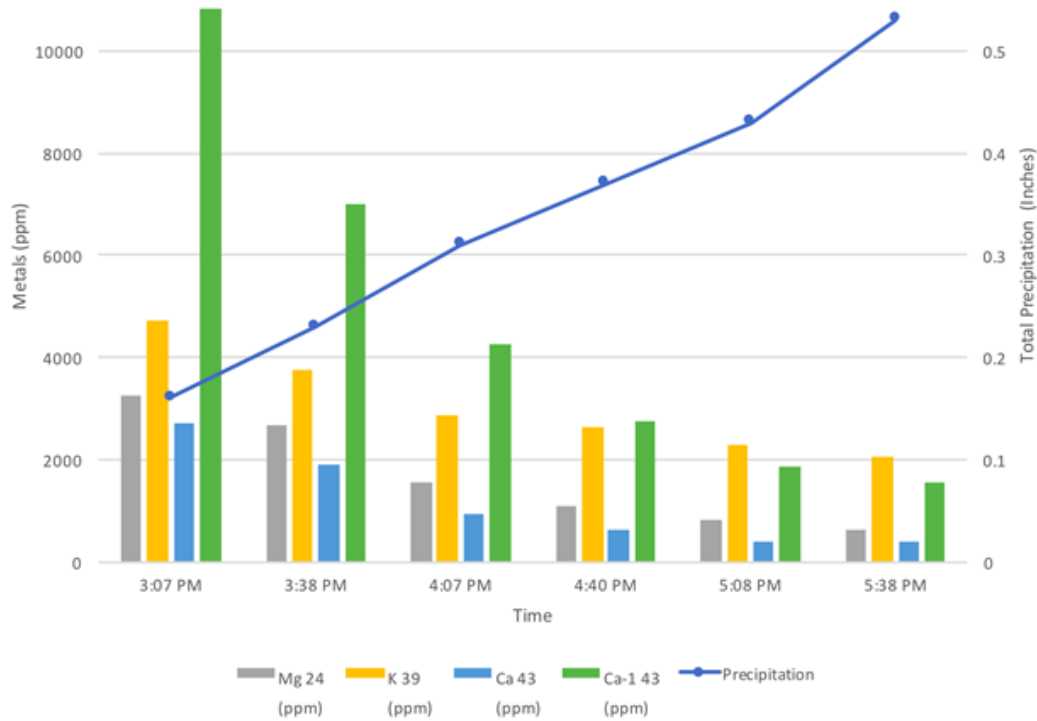

FIGURE 81: RUNOFF DISSOLVED METALS W/OUT NA WITH CUMULATIVE PRECIPITATION FROM STORM 2

Appendix I: 3 Groundwater

Figure 82 represents the groundwater samples taken throughout the basin after Storm 1. These samples were tested for dissolved metals. The highest contaminant present is Na and it is highest at location 3. Specific Conductance mirrors the Na levels, increasing from location 1 to 3 and then decreasing from that point forward out of the basin.

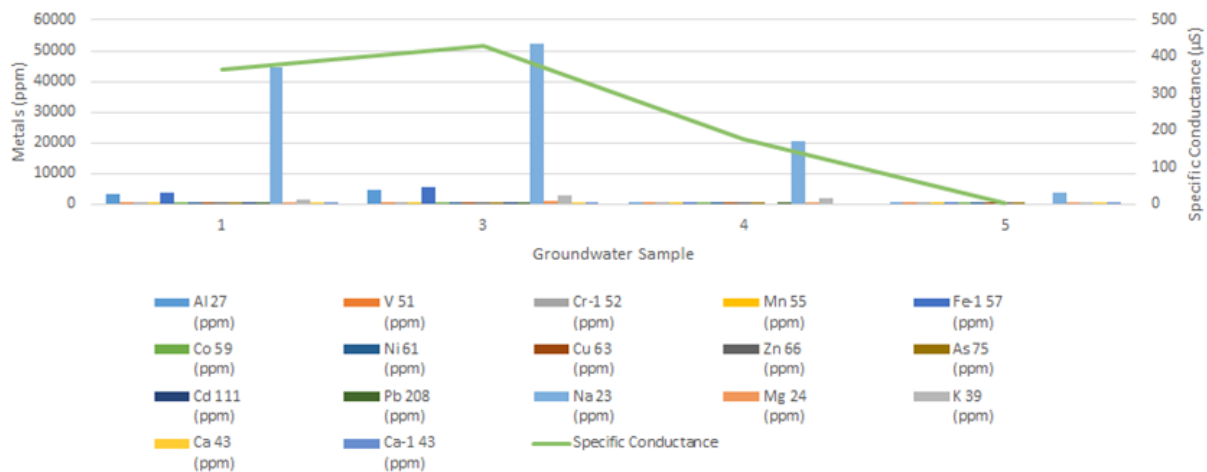

FIGURE 82: GROUNDWATER TESTED FOR DISSOLVED METALS STORM 1

Figure 83 represents Figure 82 except without Na to show the other levels of contaminants. Fe-1, Al and K are the highest contaminants present.

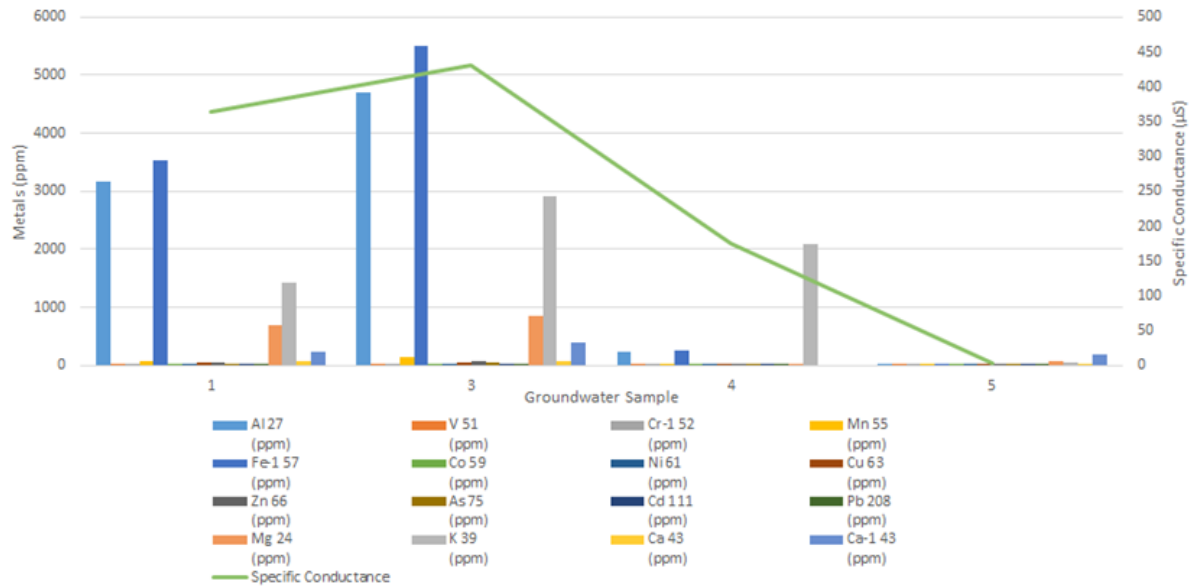

FIGURE 83: GROUNDWATER TESTED FOR DISSOLVED METALS STORM 1 WITHOUT NA

Figure 84 represents the groundwater samples tested for digested metals after the first storm. Here Na is the highest level present again. The largest spike in Na can be seen at location 5, taken outside of the basin. We can guess that there are two possibilities for why this happened. The first is that the ground water from the storm was moving and when we took samples from the furthest location it had the most sodium in it. The second is that it the groundwater tubes were not cleaned well and picked up some unwanted soil which contained high levels of Na.

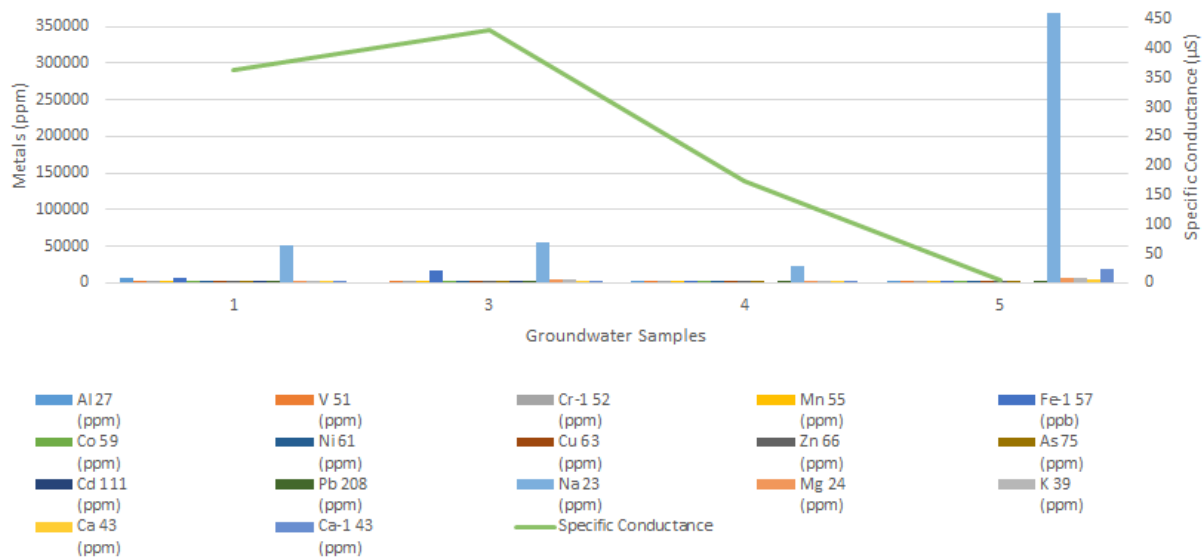

FIGURE 84: GROUNDWATER TESTED FOR DIGESTED METALS STORM 1

Figure 85 is the same as Figure 84 except without Na, revealing Fe-1 to be high at locations 1, 3, and 5. Higher levels of Al at location 1, detected levels of Mg and K at locations 3 and 5 are shown on the figure.

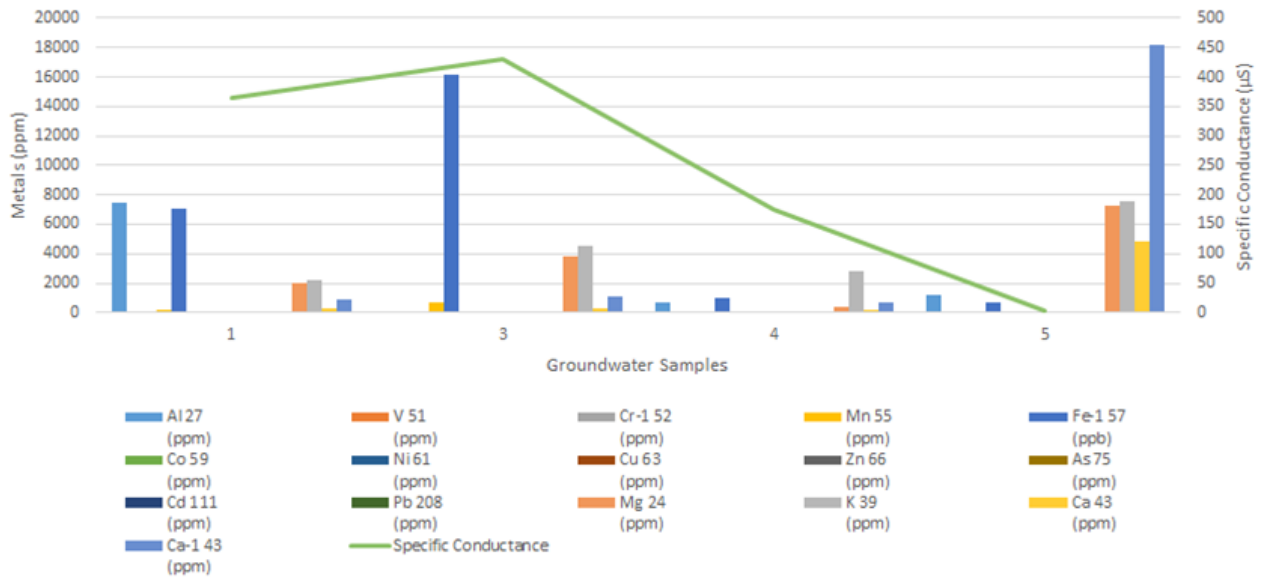

FIGURE 85: GROUNDWATER TESTED FOR DIGESTED METALS STORM 1 WITHOUT NA

This Figure 86 represents the groundwater results for dissolved metals after Storm 2. Na remains with the highest levels present and the level of specific conductance is highest in the location outside of the basin.

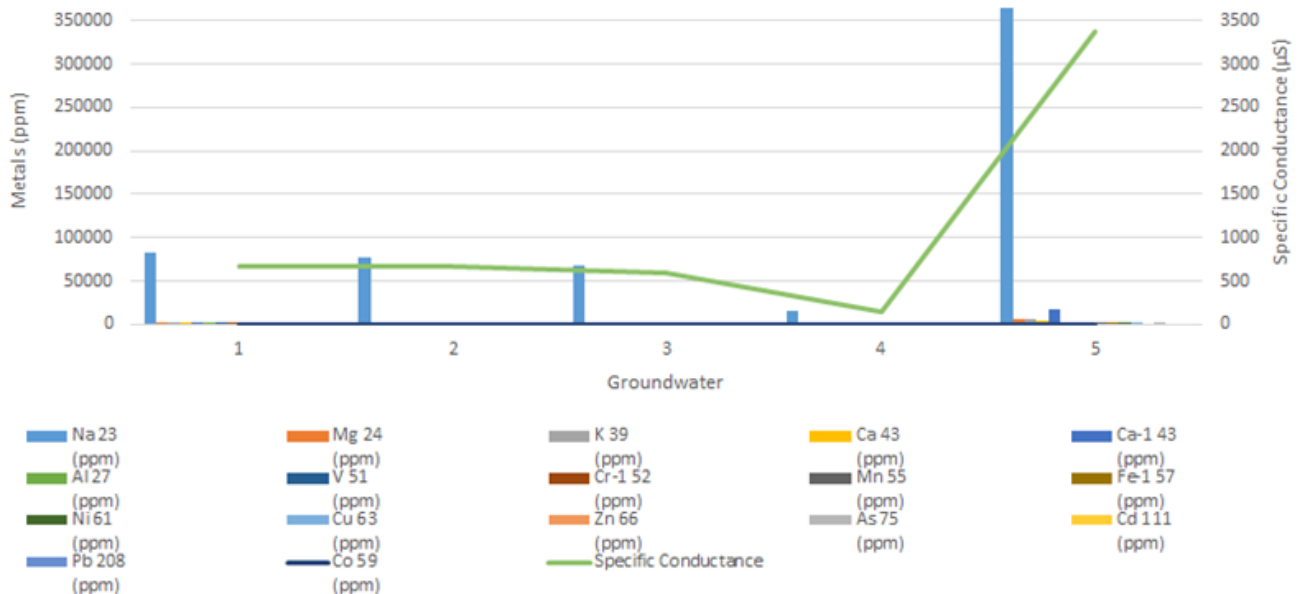

FIGURE 86: GROUNDWATER TESTED FOR DISSOLVED METALS STORM 2

Figure 87 is the same as 86 except without Na present. The highest contaminants shown in this figure are Ca-1, Mg and K.

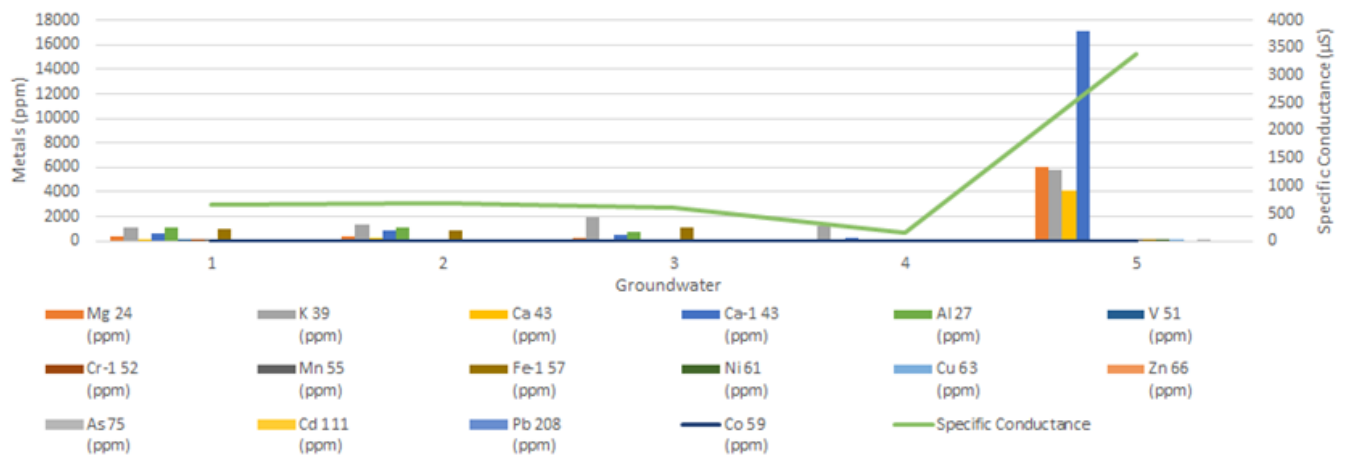

FIGURE 87: GROUNDWATER TESTED FOR DISSOLVED METALS STORM 2 WITHOUT NA

Appendix I: 4 Surface Water

Figure 88 shows the difference between the levels of TSS present upstream compared to downstream during different conditions. Furthest to the left are bars with almost identical TSS concentrations upstream and downstream that represent dry weather conditions on November 9th, 2016 around 3:30pm. The two sets of bars furthest to the right are from data collected during Storm 2, we did not collect samples during Storm 1. The samples for the middle bars were taken at 2:30 pm about 3.5 hours after the start of the storm and the bars to the furthest right were taken at 4pm or 5 hours after the start of the storm and an hour and a half before peak flow. For the Storm 2 data there is a greater amount of TSS downstream with a greater delta closer to the start of the storm. Additionally, there is a greater amount of TSS during wet weather compared to dry weather.

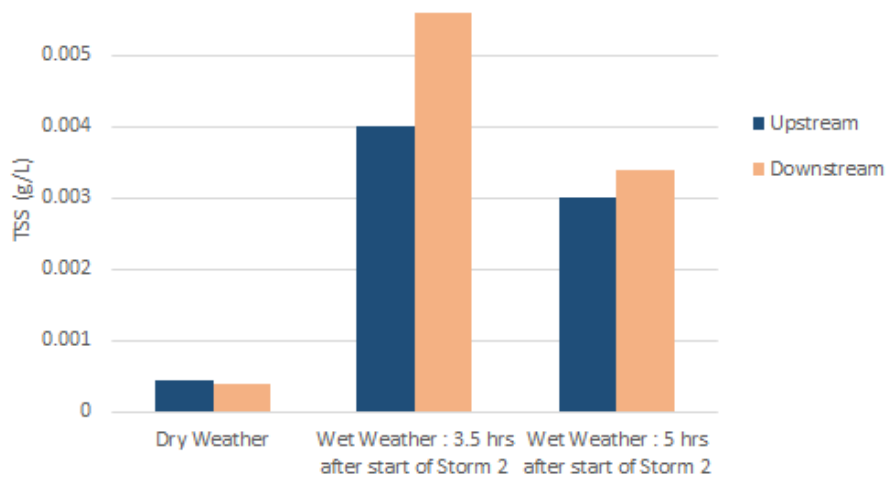

FIGURE 88: STREAM WATER TESTED FOR TSS

Figure 89 shows the relationship of the upstream and downstream locations of the Stillwater River. These samples were taken during dry weather. Specific conductance and contaminants increased downstream and highest metals found were Na and Ca-1.

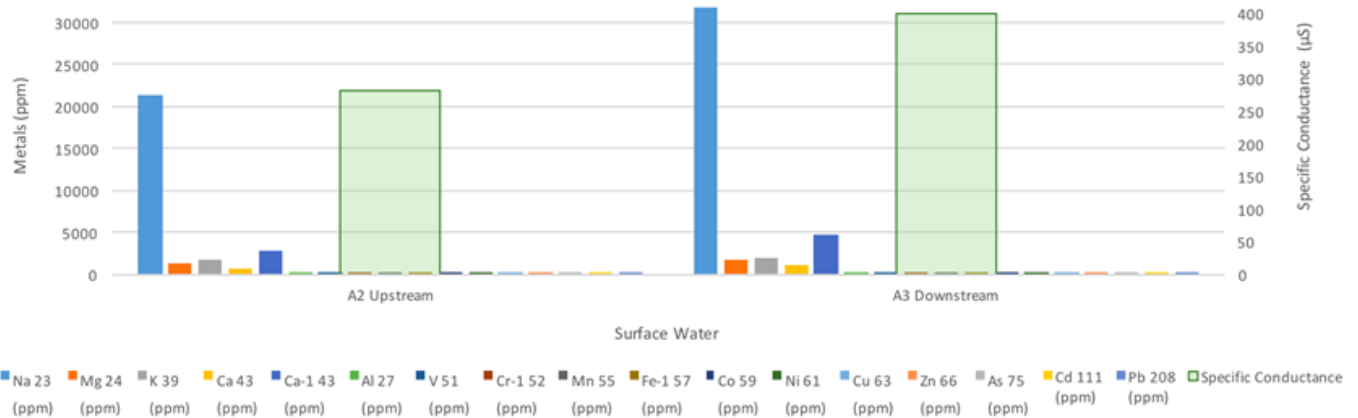

FIGURE 89: SURFACE WATER DOWNSTREAM VS. UPSTREAM TESTED FOR DISSOLVED METALS DURING DRY WEATHER

Figure 90 is the same as Figure 89 except with Na because the levels of Na were so high. This figure clearly shows the highest levels of contaminants to be Ca-1, K, and Mg.

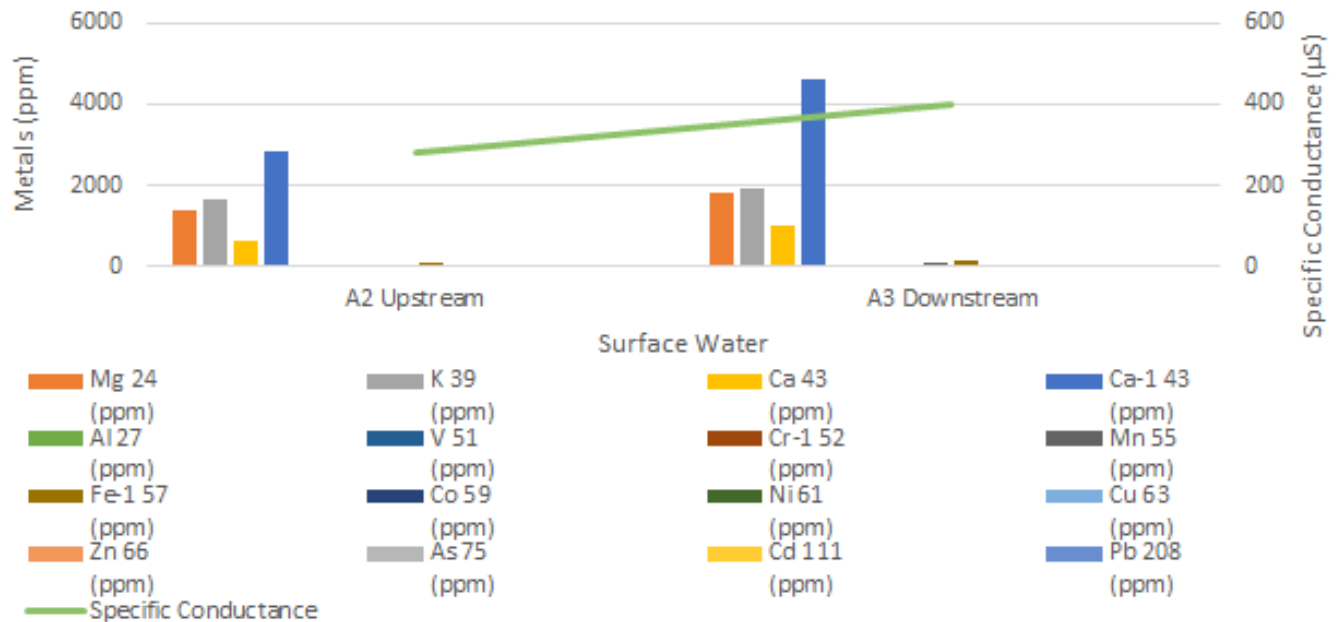

FIGURE 90: SURFACE WATER DOWNSTREAM VS. UPSTREAM DISSOLVED METALS W/OUT NA

Figure 91 show the different levels of metals present upstream and downstream in the Stillwater River during a storm on 11/29. Again Na levels were the highest present and the specific conductance increased from upstream to downstream.

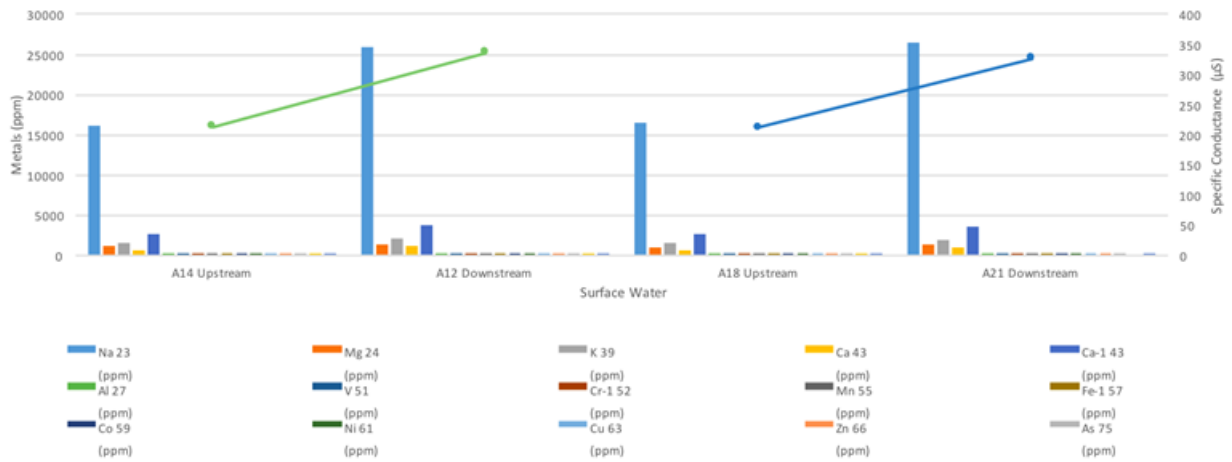

FIGURE 91: SURFACE WATER DOWNSTREAM VS. UPSTREAM TESTED FOR DISSOLVED METALS STORM 2

Figure 92 is the same as Figure 91 except without Na. Here the highest levels Ca-1, K and Mg just like Figures 89 and 90.

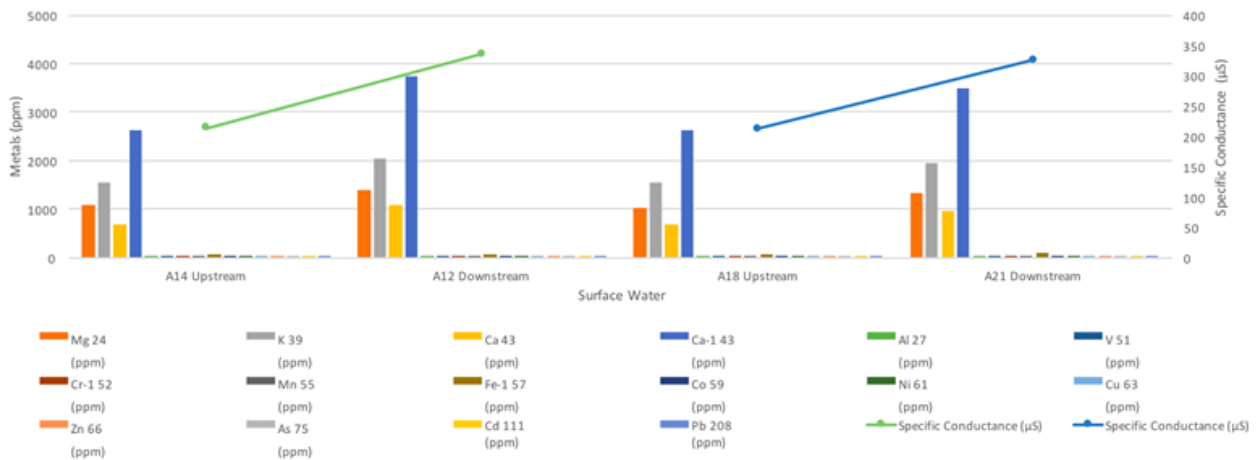

FIGURE 92: SURFACE WATER DOWNSTREAM VS UPSTREAM TESTED FOR DISSOLVED METALS STORM 2 W/OUT NA

Appendix J: USGS Storm Data

Appendix J: 1 USGS 11/15/2016 Data

Date	Time	Temperature, water, degrees Celsius	Specific Conductance, water, unfiltered, microsiemens per centimeter at 25 degrees Celsius	Precipitation, inches	Precipitation, total, inches
11/15/16	11:00	6.9	224	0	0
11/15/16	11:15	6.9	224	0	0
11/15/16	11:30	7	224	0	0
11/15/16	11:45	7	224	0	0
11/15/16	12:00	7.2	224	0	0
11/15/16	12:15	7.2	224	0	0
11/15/16	12:30	7.3	224	0.01	0.01
11/15/16	12:45	7.3	224	0	0.01
11/15/16	13:00	7.4	224	0	0.01
11/15/16	13:15	7.4	224	0.01	0.02
11/15/16	13:30	7.4	224	0.02	0.04
11/15/16	13:45	7.5	224	0.03	0.07
11/15/16	14:00	7.5	224	0.02	0.09
11/15/16	14:15	7.5	224	0.03	0.12
11/15/16	14:30	7.5	224	0.04	0.16
11/15/16	14:45	7.5	224	0.05	0.21
11/15/16	15:00	7.5	224	0.03	0.24
11/15/16	15:15	7.5	224	0.05	0.29
11/15/16	15:30	7.5	224	0.07	0.36
11/15/16	15:45	7.5	224	0.07	0.43
11/15/16	16:00	7.6	223	0.09	0.52
11/15/16	16:15	7.6	223	0.07	0.59
11/15/16	16:30	7.5	223	0.08	0.67
11/15/16	16:45	7.6	222	0.03	0.7
11/15/16	17:00	7.6	222	0.02	0.72
11/15/16	17:15	7.5	222	0.08	0.8
11/15/16	17:30	7.6	222	0.11	0.91
11/15/16	17:45	7.6	222	0.04	0.95
11/15/16	18:00	7.6	221	0.02	0.97
11/15/16	18:15	7.6	222	0.01	0.98

11/15/16	18:30	7.6	221	0.01	0.99
11/15/16	18:45	7.6	222	0.01	1
11/15/16	19:00	7.6	222	0.01	1.01
11/15/16	19:15	7.6	222	0	1.01
11/15/16	19:30	7.6	222	0.02	1.03
11/15/16	19:45	7.6	223	0	1.03
11/15/16	20:00	7.5	223	0.01	1.04
11/15/16	20:15	7.6	224	0.01	1.05
11/15/16	20:30	7.5	225	0	1.05
11/15/16	20:45	7.5	226	0.01	1.06
11/15/16	21:00	7.6	227	0	1.06
11/15/16	21:15	7.6	229	0.01	1.07
11/15/16	21:30	7.6	232	0	1.07
11/15/16	21:45	7.6	234	0	1.07
11/15/16	22:00	7.6	238	0	1.07
11/15/16	22:15	7.6	241	0	1.07
11/15/16	22:30	7.6	244	0	1.07
11/15/16	22:45	7.6	248	0.01	1.08
11/15/16	23:00	7.6	250	0	1.08
11/15/16	23:15	7.6	253	0	1.08
11/15/16	23:30	7.6	249	0	1.08
11/15/16	23:45	7.6	247	0	1.08
11/16/16	0:00	7.6	246	0	1.08
11/16/16	0:15	7.6	246	0	1.08
11/16/16	0:30	7.6	245	0	1.08
11/16/16	0:45	7.6	246	0	1.08
11/16/16	1:00	7.6	250	0	1.08
11/16/16	1:15	7.6	252	0	1.08
11/16/16	1:30	7.6	250	0	1.08
11/16/16	1:45	7.6	250	0	1.08
11/16/16	2:00	7.6	247	0	1.08
11/16/16	2:15	7.6	240	0	1.08
11/16/16	2:30	7.6	234	0	1.08
11/16/16	2:45	7.6	230	0	1.08
11/16/16	3:00	7.6	226	0	1.08

Appendix J: 2 USGS 11/29/2017 Data

Date	Time	Temperature, water, degrees Celsius	Specific Conductance, water, unfiltered, microsiemens per centimeter at 25 degrees Celsius	Precipitation, inches	Precipitation, total, inches
11/29/16	10:00	3.5	191	0	0
11/29/16	10:15	3.5	191	0	0
11/29/16	10:30	3.5	191	0	0
11/29/16	10:45	3.5	191	0	0
11/29/16	11:00	3.5	191	0.01	0.01
11/29/16	11:15	3.6	191	0	0.01
11/29/16	11:30	3.6	190	0.01	0.02
11/29/16	11:45	3.6	190	0.01	0.03
11/29/16	12:00	3.7	190	0	0.03
11/29/16	12:15	3.7	190	0	0.03
11/29/16	12:30	3.7	190	0	0.03
11/29/16	12:45	3.7	190	0.01	0.04
11/29/16	13:00	3.7	190	0.01	0.05
11/29/16	13:15	3.8	190	0.01	0.06
11/29/16	13:30	3.8	190	0	0.06
11/29/16	13:45	3.8	190	0.01	0.07
11/29/16	14:00	3.8	190	0.02	0.09
11/29/16	14:15	3.9	190	0.01	0.1
11/29/16	14:30	3.8	190	0.02	0.12
11/29/16	14:45	3.9	190	0.01	0.13
11/29/16	15:00	3.9	190	0.03	0.16
11/29/16	15:15	3.9	190	0.03	0.19
11/29/16	15:30	3.9	190	0.04	0.23
11/29/16	15:45	3.9	190	0.04	0.27
11/29/16	16:00	3.9	190	0.04	0.31
11/29/16	16:15	4	191	0.02	0.33
11/29/16	16:30	4	192	0.04	0.37
11/29/16	16:45	4	193	0.03	0.4
11/29/16	17:00	4	194	0.03	0.43

11/29/16	17:15	4.1	195	0.04	0.47
11/29/16	17:30	4.1	196	0.06	0.53
11/29/16	17:45	4.1	197	0.05	0.58
11/29/16	18:00	4.1	198	0.04	0.62
11/29/16	18:15	4.2	198	0.03	0.65
11/29/16	18:30	4.2	199	0.01	0.66
11/29/16	18:45	4.2	200	0.01	0.67
11/29/16	19:00	4.3	202	0.02	0.69
11/29/16	19:15	4.3	203	0	0.69
11/29/16	19:30	4.3	206	0	0.69
11/29/16	19:45	4.4	207	0	0.69
11/29/16	20:00	4.4	209	0	0.69
11/29/16	20:15	4.4	210	0	0.69
11/29/16	20:30	4.5	212	0	0.69
11/29/16	20:45	4.5	214	0	0.69
11/29/16	21:00	4.5	215	0	0.69