



Alternative and Renewable Energy

An Interactive Qualifying Project

Submitted to the Faculty of the

WORCESTER POLYTECHNIC INSTITUTE

Advisor: Professor Mayer Humi

Submitted by

Ni Pan

Qiao Li

Jizhang Xu

Tianyu Li

March 14, 2014

Abstract

The current state of energy, in the most optimistic projections, is a finite resource that will be exhausted during the 21st century. This project examines the current using traditional energy resources limitations, investigates existing research on several renewable energy alternatives, and also researches energy policy of various countries in the world. We concentrated on hydropower and examine its potential and new technologies. Finally, we introduce the energy policy we recommended and an outlook for the future.

Contents

1	Traditional Energy	9
1.1	Coal	10
1.2	Oil	14
1.3	Natural Gas	16
1.3.1	Overview	16
1.3.2	Fracking	19
1.4	Nuclear Energy	22
1.4.1	Overview	22
1.4.2	Generation IV	24
2	Renewable Energy	29
2.1	Solar Energy	29
2.2	Wind Energy	35
2.3	Biofuel	43
2.3.1	Overview	43
2.3.2	Algae Fuel	44
2.4	Hydropower & Wavepower	47
3	Energy Policy	50
3.1	United States	50
3.2	Europe Union	51
3.3	Japan	55
3.4	Australia	59
3.5	Russia	61
3.6	India	63
3.6.1	Challenges	63
3.6.2	Policy	64
3.6.3	Rural Electrification	64
3.7	Brazil	65
3.7.1	Energy Conservation (Efficiency)[85]	66
3.7.2	Renewable energy	67
3.8	China	68
3.8.1	Present status	68
3.8.2	Policy for China	70

4	Solutions to Energy Problem: Topics on Hydropower	72
4.1	Hydro Technology	72
4.2	Gulf Stream	74
4.2.1	Basic Information	74
4.2.2	Data	75
4.2.3	Formation (Energy Source of the Gulf Stream)	75
4.2.4	Calculation of mean power	76
4.3	Bay of Fundy	79
4.4	Hydropower and Ocean power in China	85
4.4.1	Tidal Energy	88
4.4.2	Marine Current Energy	90
4.4.3	Wave Energy	90
5	Conclusion	93
	Bibliography	95

List of Figures

1.1	US primary energy consumption estimates by source, 1950-2011[16]	9
1.2	World Coal Consumption by Year[16]	11
1.3	Data regarding Coal Prices from 1987-2012[107]	12
1.4	US Coal Spot Price Index[107]	13
1.5	World Bank Commodity Forecast Price Data, July 2013[72]	14
1.6	World oil consumption 1965-2012[33]	15
1.7	Oil prices in WTI, Brent and Dubai 1976-2012[33]	16
1.8	Global natural gas consumption[30][64]	17
1.9	US natural gas price[15]	18
1.10	US natural gas wellhead price[15]	19
1.11	Hydraulic Fracturing (Fracking)[45]	20
1.12	Worldwide Natural Gas Resources[102]	20
1.13	Schematic geology of natural gas resources[15]	21
1.14	Composition of fracking fluid[5]	22
1.15	World low carbon energy consumption[81]	23
1.16	World Nuclear Consumption by Year[8]	24
1.17	World Electricity Production by Year[24]	25
2.1	Percentage of solar in renewable energy[59]	30
2.2	Earth's Energy Budget[83]	31
2.3	Solar Collector System[83]	32
2.4	How fuel cell works[55]	34
2.5	Projected Transportation Fuel Cell System Cost[65]	35
2.6	Global Annual Installed Wind Capacity 1996-2012 [6]	36
2.7	Cumulative Installed Capacity Forecast[94]	37
2.8	Tip-speed ratio Vs. Power Coefficient[46]	38
2.9	Airfoil aerodynamics[46]	39
2.10	Net Aerodynamic force on blade[46]	39
2.11	Two Detached-flow Conditions[46]	40
2.12	Angle of Twist[46]	41
2.13	Typical Airfoil shapes[46]	42
2.14	Optimum Blade Planform[46]	43
2.15	Wind farms Location distribution[49]	44
2.16	Combined wind power capacity according to states[124]	45
2.17	Global biofuel production from 1990 to 2012[33]	45

2.19	Various Feedstocks and their potential oil yield per acre Note: g/m ² /day is the harvest rate of the algae and % TAG is the percentage of triglycerides[61]	45
2.18	Algae fuel cycle[86]	46
2.20	Algae Fuel Cost[89]	47
2.21	Prediction of the price of algae fuel in 2020 (All producers are come from industry related to algae-based fuel.)[93]	48
3.1	Energy in the world(overview)[77]	52
3.2	Energy consumption of European Union[77]	53
3.3	Energy import of European Union by country and by fuel[77]	54
3.4	Electricity generation from renewable energy in Australia[41]	60
3.5	Russia's oil production and consumption[15]	61
3.6	Export destinations of Russia crude oil[18]	62
3.7	Export destinations of Russia natural gas[17]	62
3.8	Nabucco Gas Pipeline[121]	63
3.9	Total energy consumption in India[15]	64
3.10	India Rural Electrification[91]	65
3.11	Brazil total primary energy consumption by year[1]	65
3.12	Total and final energy consumption trends[1]	66
3.13	Efficiency of power generation and thermal power plants & Electric T&D losses[1]	67
4.1	An diagram of Pumped-Storage Plant[27]	72
4.2	Renewable energy[126]	75
4.3	Surface mean current speed of Gulf Stream[128]	76
4.4	Width and depth of Gulf Stream[128]	77
4.5	Streamline of Gulf Stream based on Stommel Model[128]	78
4.6	Velocity vector and streamline of Gulf Stream[128]	79
4.7	Maximum of dissipation from turbine[128]	79
4.8	Bay of Fundy[97]	80
4.9	Bathymetry(m) of the Region[67]	81
4.10	The Location of Nine Observation Station[36]	82
4.11	Numerically Simulated Amplitude and Phase[80]	83
4.12	Power Density in the Minas Passage (Unit: kW/m^2)[80]	84
4.13	An Underwater Turbine in Cobscook Bay[127]	84
4.14	The distribution of economically exploitable resources in China[75]	86
4.15	Growth of hydropower in China[53][40][39]	86
4.16	Location of 13 Hydropower Bases in China[99]	87
4.17	Tidal Energy Resources Distribution in China[90]	89
4.18	Tidal Current Energy Resources Distribution in China[90]	91
4.19	Wave Energy Resources Distribution in China[90]	92

Executive Summary

The goal of this project is to analyze the current state of global energy resources, determine the energy outlooks and recommend possible solutions. We first researched the main energy resources we typically used today, which include coal, oil, natural gas and nuclear power. According to the most optimistic prediction the world coal reserve is 948 billion short tons that will be exhausted in 129 years, the world oil reserve is 235,800 million tons that will be exhausted in 40 years, and for natural gas the worlds proved reserve is 187.3 trillion cubic meters, which will be exhausted in 74 years. All of those imply we will exhaust traditional fossil fuels in the 21st century; also although the use of nuclear power is relatively effective, it has serious problems on safety issues and the disposal of nuclear waste. The world is sleepwalking to a global energy crisis, and it is urgent to start looking for alternative energy sources that will be in place before we hit the crisis.

For alternatives we look at solar energy, wind energy, biofuel, and hydropower. Solar energy is a great choice since the surface of earth receives 120,000 terawatt of solar radiation each year and it is available as long as the sun is alive, which about another 6.5 billion years; however the currently solar power is not viable due to its high cost on solar panels, access to sunlight is limited at certain times, and energy storage is very expensive and inefficient. Wind power seems like to be a great choice since it has enormous potential which is 20 times more than what the entire human population needs and it has efficiencies upwards of 50%, but it is infeasible due to its inconsistent (wind is a intermittent source) and the noise from turbines. Biofuel is also a competitive alternative since it could absorb carbon dioxide as it grows and both waste CO₂ and wastewater can be used as nutrients, but it isn't a particularly efficient method of generating power, since it requires a considerable amount of land and water, and requires phosphorus as a fertilizer which is becoming scarce. Since all of these options are not ideal, we decide to concentrate on hydropower.

Hydropower is electricity generated using the energy of moving water. It is a renewable energy, which requires no fuel, it is reliable and predictable, and it has high efficiency. Although hydropower has its limitations, it still has great potentials. We look specific in two sites, the Bay of Fundy and the Gulf Stream. We found out that the hydropower-generated electricity is twice the fossil-fuel-

generate price, but if we put in environmental impact and from the long run hydropower is more suitable for our current path of energy development.

Introduction

Nowadays social development of human being growth rapidly. We are at the key point of the fastest urban growth in human society, which leads to the continually improvement of living standards and the increasing of social productivity. At the same time we are suffering from the substantial increase in energy demand and energy use caused by rapid economic development. We need energy for everything from car engine to household appliances.

Energy plays a fundamental role in shaping the human condition. People's need for energy is essential for survival, energy is also essential to the advance of civilization, that the evolution of human societies is dependent on the conversion of energy for human use.

Before the modern era, people relied for power on their own muscles, on the muscles of livestock, such as horses and buffalo, and on water wood and wind.

The modern era began with introduction of steam power which accelerate the eighteenth century's industrial revolution, and it promoted large scale of coal mining. In 1860, the coal consumption is 24%, by 1920 it grew to be 62%, and the world entered the age of coal.

In 1970s electric power replaced steam engine, electrical industry was booming, and the coal consumption was gradually decline. In 1965, oil replaced coal, which became the largest consumption resource, the world jump to the oil era.

Due to the uneven distribution of energy resources, the rapid growth of world's population, and the continually improvement of living standards; the needs for energy is enormous. Those needs resulting the increasingly fierce competition over the energy fight, and serious environmental pollution.

Oil currently has the most world consumption but we are facing the depletion crisis. Fossil fuels massive mining and utilization cause the air pollution and the ecological environment destruction. Therefore developing and transition to new alternative energy is inevitable.

Chapter 1

Traditional Energy

Most of the energy we used now is from nonrenewable energy sources: oil, natural gas, and coal, and we know them as fossil fuels. Fossil fuels are fuels formed by natural processes such as anaerobic decomposition of buried dead organisms. The age of the organisms and their resulting fossil fuels is typically millions of years, and sometimes exceeds 650 million years. Fossil fuels contain high percentages of carbon and include coal, petroleum, and natural gas.[105]

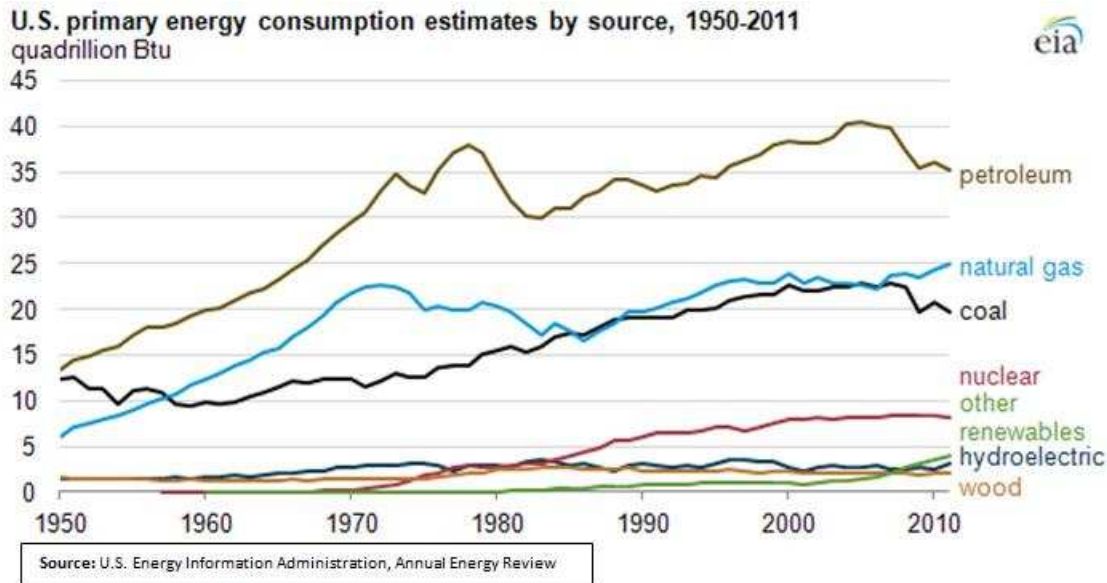

Figure 1.1: US primary energy consumption estimates by source, 1950-2011[16]

While the United States produced a record 78 quadrillion Btu (quads) of energy in 2011, it consumed more than 97 quads of energy in various forms. Nonrenewable fossil fuels made up more than four-fifths of U.S. energy consumption.

As has been the case since 1950, petroleum was the most-consumed fuel in 2011, at 35.3 quads. Use of petroleum, which includes crude oil as well as natural gas plant liquids, has

fallen recently from its peak historical level of 40.4 quads in 2005. Natural gas, which had been consumed in roughly equal amounts to coal for several years, accounts for almost 25 quads compared to coal's 20 quads in 2011. Natural gas and renewable energy were the only fuel sources whose consumption increased in 2011.[20]

1.1 Coal

Coal is one of the most important sources of energy and is being used for various purposes such as heating of houses, as fuel for boilers and steam engines and for generation of electricity by thermal plants. Coal has also become a precious source of production of chemical of industrial importance coal is and will continue to be the mainstay of power generation.[114]

Throughout history, coal has many important uses worldwide. Different types of coal have different uses. Steam coal is mainly used in power generation like electricity. Coking coal[9] is converted to coke by driving off impurities to leave almost pure carbon, and it is mainly used in steel production. The most significant uses of coal are burned for producing electricity and heat, and are also used for industrial purposes such as refining metals. According to the source and data from United States Energy Information Administration[47], since 2010 global coal consumption has grown faster than any other fuels, at an increasing rate of approximately 4% per year. The five largest coal users are China, US, India, Russia and Japan account for 76% of total global coal use. World coal consumption was about 7.99 billion short tons and is expected to increase 48% to 9.98 billion short tons by 2030. In China, about 68.7% of electricity is generated from coal; In US, 46% of the total power was done by coal. Of the world at least 40% electricity comes from coal. One thing should be noted, however, is in US as of 2012, use of coal to generate electricity was declining, as natural gas can be obtained at lower prices.

Here in order to better estimate the coal consumption in the future, we collected the total consumption of coal in the world from 1980-2011[11] and plotted the data by year. The chart below is our plotted data:

In order to model the above plotted data, several choices were being considered. There are several mathematical models[8] can be discussed for this plot, such as exponential growth, exponential decay (increasing form) and logistics growth model. Some of the things that exponential growth is used to model include population growth or bacterial growth, however, in our graph even though it seems to be increase in exponentially but it is increasing slowly. Thus we would consider the other two models left.

Considering with the development of technology and limited recoverable coal reserves, the total worlds coal consumption in the future will eventually slow down and remain at a certain level. For our plot it would be better to choose the logistics growth model mentioned above because we can see from the graph that during year 1989-1998, the worlds total coal consumption is actually almost flat or even decreased due to the energy crisis. Therefore we would use the logistics growth model to make a better estimation.

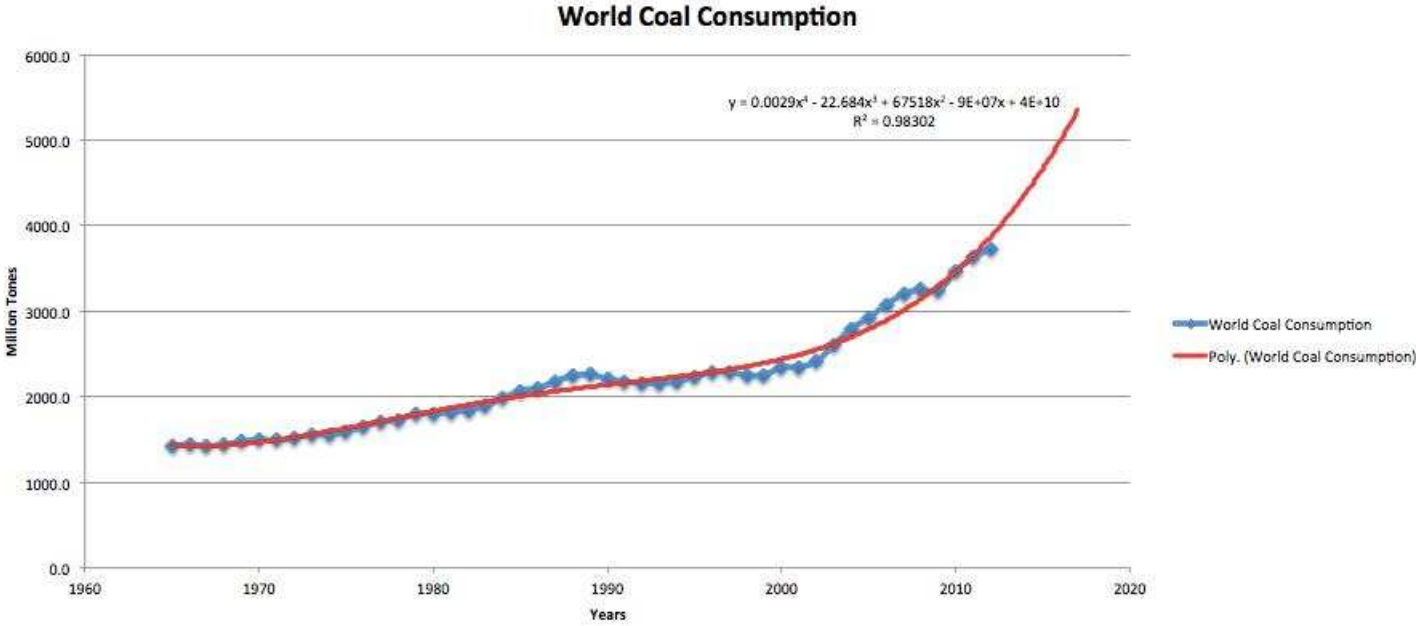

Figure 1.2: World Coal Consumption by Year[16]

Because the coals are buried underground, it is impossible to know exactly how much is left. But estimations still can be made. Here the Estimated recoverable reserves[10] will be used, which means only including the coal that can be mined with today's mining technology, after accessibility constraints and recovery factors are considered. Compared to all other fossil fuels, coal is the most abundant and is widely distributed across the continents worldwide. The estimate for the world's total recoverable reserves of coal as January 1, 2009 was 948 billion short tons. This data was obtained from the US Energy Information Administration[10]. The resulting ratio of coal reserves to consumption is approximately 129 years, meaning that at current estimated rates of consumption, current coal reserves could last that long. From the mathematical model we got from the collected data, we could predict the world coal consumption will be continuously increasing in the near 30-50 years.

With the increasing rate of coal consumption worldwide, there are at the same time also many related problems occurring along with the coal consumption. Coal mining brings a lot of environmental issues, such as soil erosion, dust, noises and water pollution. The greenhouse gas (GHG) emissions are significant while burning coals and these eventually will cause the global warming. Air pollution will probably be more and more severe because of the increasing inhalable particle matters of burning, which will affect human health.

The world's total recoverable reserves of coal could be seen as enough for our generation, but for the next generation what can be consumed would be far less than right now and people will be facing severe energy shortage problems. Nowadays, people are still working hard on finding alternative energy resources like solar energy or more efficient resources to help us deal

with the current obstacles. However, there are still many other aspects need to be considered, such as price, stability, efficiency, etc., before shifting our current energy resource to a new field.

Usually, price goes up with the demand. Therefore, the coal price is related to the coal consumption. The data regarding coal prices showed below is obtained from company BPs website.[31] This coal prices are calculated as cif prices[31], where cif = cost + insurance + freight (average freight prices). All prices are quoted in US dollars per tonne.

A	B	C	D	E	F
Coal: Prices					
US dollars per tonne	Northwest Europe marker price †	US Central Appalachian coal spot price index ‡	Japan coking coal import cif price	Japan steam coal import cif price	Asian Marker price †
1987	31.30	-	53.44	41.28	-
1988	39.94	-	55.06	42.47	-
1989	42.08	-	58.68	48.86	-
1990	43.48	31.59	60.54	50.81	-
1991	42.80	29.01	60.45	50.30	-
1992	38.53	28.53	57.82	48.45	-
1993	33.68	29.85	55.26	45.71	-
1994	37.18	31.72	51.77	43.66	-
1995	44.50	27.01	54.47	47.58	-
1996	41.25	29.86	56.68	49.54	-
1997	38.92	29.76	55.51	45.53	-
1998	32.00	31.00	50.76	40.51	29.48
1999	28.79	31.29	42.83	35.74	27.82
2000	35.99	29.90	39.69	34.58	31.76
2001	39.03	50.15	41.33	37.96	36.89
2002	31.65	33.20	42.01	36.90	30.41
2003	43.60	38.52	41.57	34.74	36.53
2004	72.08	64.90	60.96	51.34	72.42
2005	60.54	70.12	89.33	62.91	61.84
2006	64.11	62.96	93.46	63.04	56.47
2007	88.79	51.16	88.24	69.86	84.57
2008	147.67	118.79	179.03	122.81	148.06
2009	70.66	68.08	167.82	110.11	78.81
2010	92.50	71.63	158.95	105.19	105.43
2011	121.52	87.38	229.12	136.21	125.74
2012	92.50	72.06	191.46	133.61	105.50

† Source: McCloskey Coal Information Service. Prices for 1990-2000 are the average of the monthly marker, 2001-2012 the average of weekly prices.
‡ Source: Platts. Prices are for CAPP 12,500 Btu, 1.2 SO2 coal, fob.
Prices for 1990-2000 are by coal price publication date, 2001-2012 by coal price assessment date.
Note: CAPP = Central Appalachian; cif = cost+insurance+freight (average prices); fob = free on board.

Figure 1.3: Data regarding Coal Prices from 1987-2012[107]

The above data is plotted in the graph showing below:

Clearly there is a coal price spike in 2008 observed from the above plotted chart. Merrill Lynch has predicted that the prices will jump by as much as 200 percent in 2008.[82] This can also be observed from the data collected from BPs website[31], that the coal price index jumped from around 51 to 118 in 2008. The main reason of causing this price spike is the supply disruptions resulted in a severe global shortage. The flooding in Australia's Queensland state removed about 15 million tonnes of coking coal from the export market. In addition the heavy snowstorms have slowed Chinese coke export[4]. The rising energy and environmental cost issues are also likely to curb stronger China coke production, said by ANZs senior commodity strategist, Mark Pervan.[4] According to Merrill Lynch, due to these

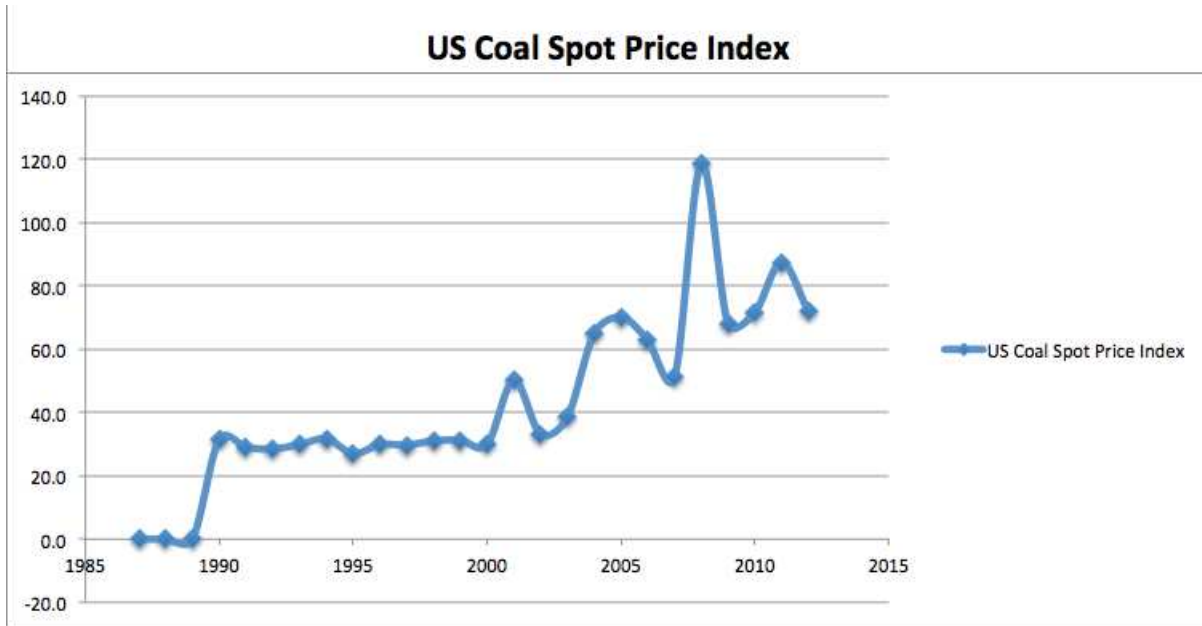

Figure 1.4: US Coal Spot Price Index[107]

supply disruptions from Australia, China and South Africa, combined with powerful Asian demand, would result in supply deficit of 160 million tonnes for thermal coal in 2008. This spike is also Temporary because of the severe weather condition in 2008. The coal price would significantly fall back after 2008 due to the recovery from the shortage. Another smaller spike can be observed from the graph in year of 2011. This is mainly caused by the increasing demand of coal in China and Australian coal supplies showed signs of tightening.

Since Australia is the worlds largest coal exporter, as it exports roughly 70% of coal production.[118] A predication of coal price in the near future will be made based on Australia coal market. In the face of growing tax, production and environmental regulation pressures, plus the limited coal reserves and the continuously increasing coal consumption, the coal price will be increasing modestly regardless the supply shortage caused by unforeseen reason.

The price of coal doesn't increase significantly along with the increasing coal consumption. Even though the price will not increase dramatically, the coal reserves are limited and will be used up one day. Therefore, alternative way of dealing energy problem needs to be come up with for future severe energy situation.

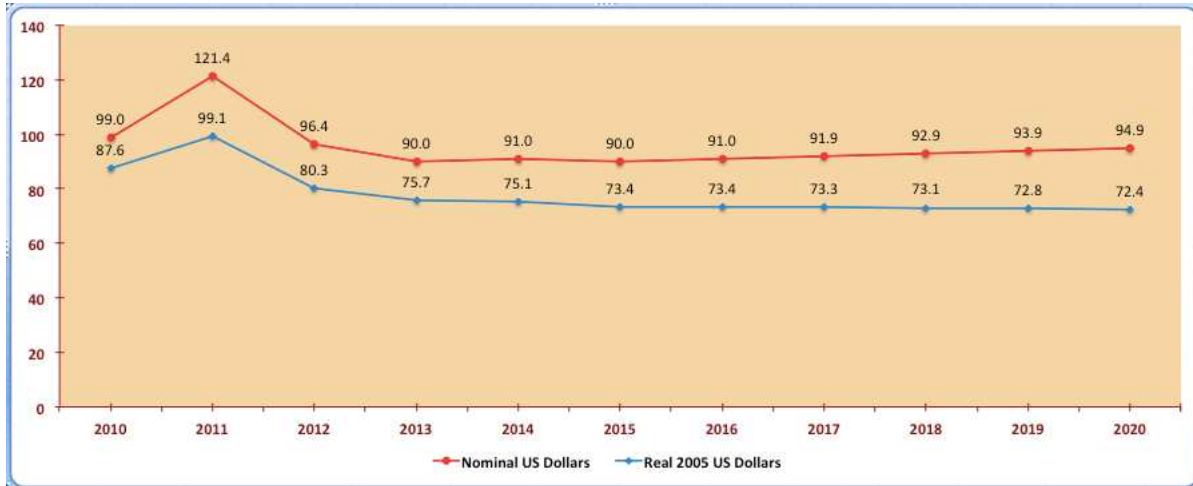

Figure 1.5: World Bank Commodity Forecast Price Data, July 2013[72]

1.2 Oil

Petroleum is formed by hydrocarbons (a hydrocarbon is a compound made up of carbon and hydrogen) with the addition of certain other substances, primarily sulphur. Petroleum in its natural form when first collected is usually named crude oil, and can be clear, green or black and may be either thin like gasoline or thick like tar. There are several major oil-producing regions around the globe. The Kuwait and Saudi Arabia's crude oil fields are the largest, although Middle East oil from other countries in the region such as Iran and Iraq also make up a significant part of world production figures.

Note that there are declines in 1974, 1980, 1992 and 2009. In 1973, 1979 and 1991, there were three oil crises, which cause the decline of oil production and consumption. 1974, 1980 and 1992: three oil crisis. In 2008, the global financial crisis happened. It made the economy depress and decline the oil consumption. Otherwise, the world oil reserve in 2012 is 235 800 million tons.

Figure 7 shows us the price of oil in three major crude oil prices: West Texas Intermediate, Brent Blend and Dubai Crude from 1976 to 2012. The three curves variation trend are similar, thus I think they can stands for the global oil price.

Figure 1: World oil consumption from 1965 to 2012 (unit: Million tons)

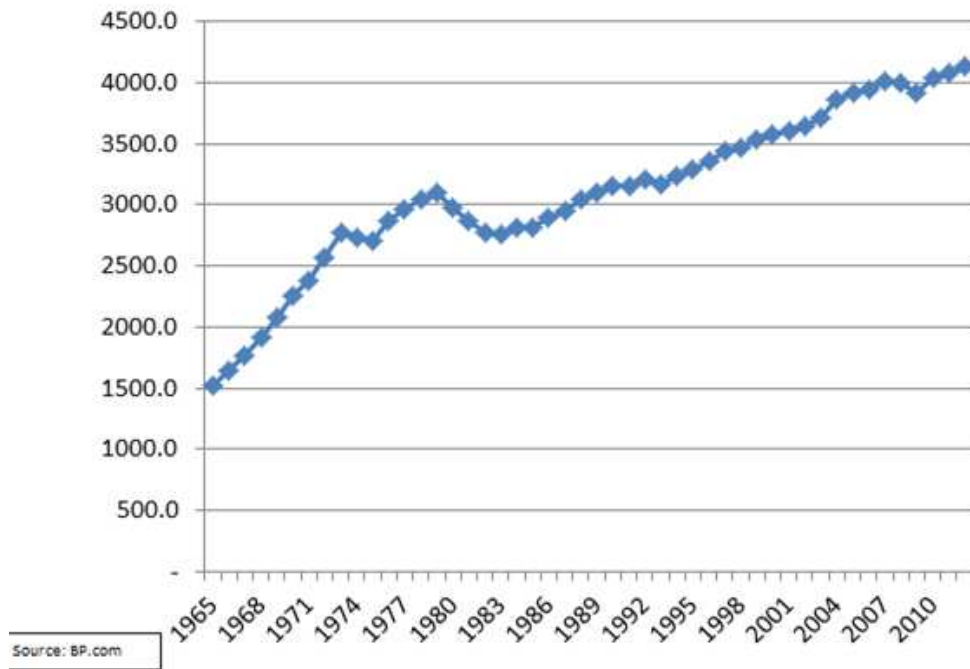

Figure 1.6: World oil consumption 1965-2012[33]

The reason is that the price depends on many factors including supply-demand relationship, economy, politics, OPEC, etc. However, the consumption is mainly depends on the demand of industrial production and transportation. Thus I do not think that the price would be a considerable factor in oil consumption.

Oil Prices in WTI, Brent and Dubai from 1976 to 2012

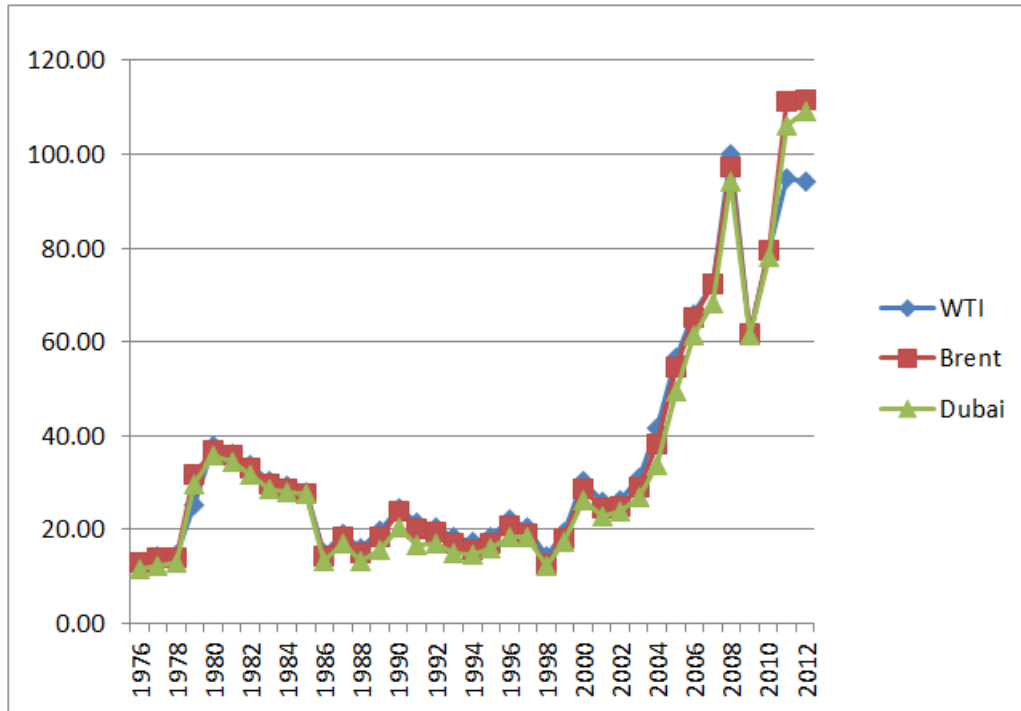

Figure 1.7: Oil prices in WTI, Brent and Dubai 1976-2012[33]

1.3 Natural Gas

1.3.1 Overview

Natural gas is a mixture of several hydrocarbon gases, including methane (between 70% and 90%), ethane, propane, butane and pentane, as well as carbon dioxide, nitrogen and hydrogen sulphide. The composition of natural gas can vary widely, depending on the gas field. Natural gas is referred to as wet when hydrocarbons other than methane are present, dry when it is almost pure methane, and sour when it contains significant amounts of hydrogen sulphide.

The Global natural gas demand was estimated at 3 284 billion cubic metres (bcm) in 2010, up 7.4% from 2009 levels. Gas demand has increased by around 800 bcm over the last decade, or 2.7% per year. Gas has a 21% share in the global primary energy mix, behind oil and coal. For comparison, 50 billion cubic meters (bcm) of natural gas is roughly equivalent to 7% of the USs consumption in 2010, or Frances entire annual consumption in 2010. In terms of volume, 50 bcm could fill roughly 20 million Olympic swimming pools([88]).

The graph above shows the natural gas overview for the last 40 years. The blue line shows the natural gas production, the orange line shows the natural gas consumption, and the green line is the trendline of the consumption of natural gas. Starting at 1970 the graph shows a step increase until now. The keep rising of natural gas consumption and production due to

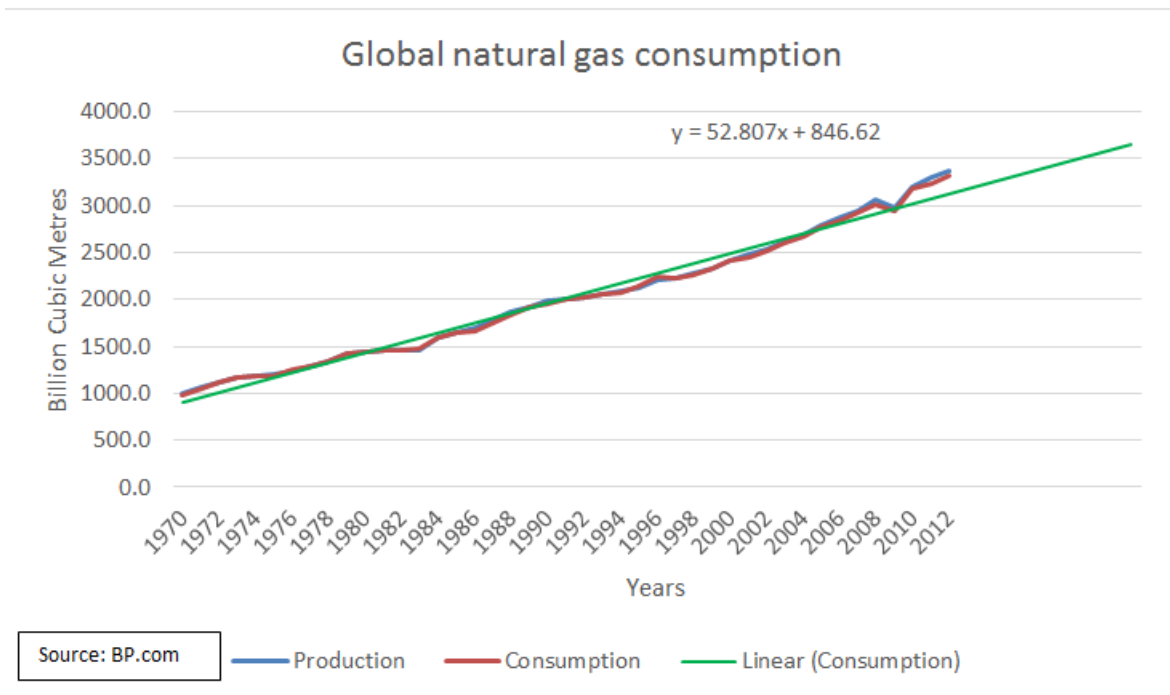

Figure 1.8: Global natural gas consumption[30][64]

the rise of energy needs over the last 40 years.

By observing the consumption graph I decide to use a linear trendline to model the consumption graph. The linear equation is $y = 52.807x + 846.62$.

The price that residential consumers pay for natural gas has two main parts (all cost components include a number of taxes):

1. Commodity costs: the cost of the natural gas itself, known as the wellhead cost, which showed by the graph above as blue line.
2. Transmission and distribution costs: the cost to move the natural gas by pipeline from where it is produced to the customer's local gas company, and to bring the natural gas from the local gas company to the customer's house. These transmission and distribution costs account for the difference between the price of natural gas at the wellhead and the price paid by residential customers[100].

From 1954 to 1978, the Federal Power Commission regulated the price of natural gas transported through the interstate pipeline system. Under this system, price setting was based on production costs and applications for rate increases moved slowly through the bureaucratic process. As a result, prices changed very little from year to year. As seen in the graph above, from 1954 to 1978, wellhead prices averaged \$0.21 per thousand cubic feet (mcf), with an annual standard deviation of \$0.20 per mcf.

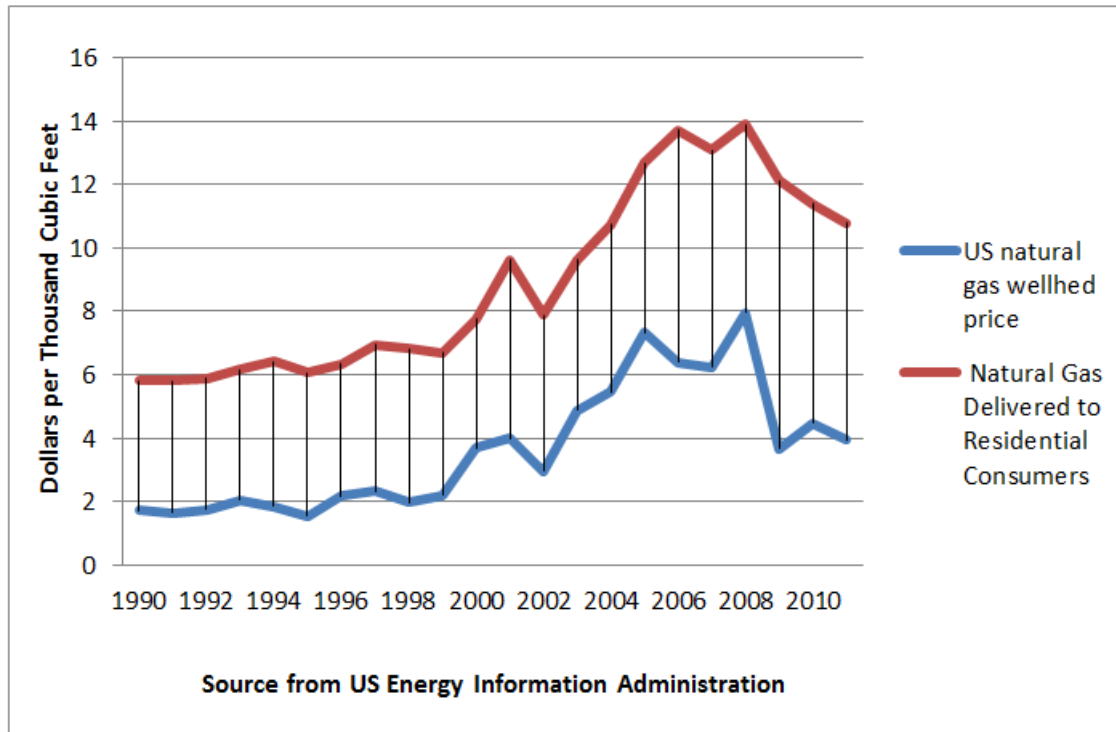

Figure 1.9: US natural gas price[15]

Although phased deregulation began with the passage of the Natural Gas Policy Act of 1978, prices began to rise in the mid-1970s, a period of turmoil in international energy markets that saw a sharp increase in crude oil prices. Eventually, natural gas prices peaked in 1984 at \$2.66 per mcf (nominal).

Prices subsequently retreated modestly and then remained fairly stable for several years: From 1986 to 1999, natural gas prices averaged \$1.87 per mcf, with a standard deviation of \$0.24 per year[66].

Following the 2001 recession, natural gas prices began to rise noticeably. However, by the year 2008 the use of hydraulic fracturing, which refers to the procedure of creating fractures in rocks and rock formations by injecting fluid into cracks to force them further open, and the larger fissures allow more oil and gas to flow out of the formation and into the wellbore[32], from where it can be extracted, makes the natural gas price went down dramatically from \$7.97 per mcf to \$2.66 per mcf. By the end of 2012 the natural gas proved reserve is 187.3 trillion cubic meters[9].

Much more available natural gas in places that employ fracking, most notably the United States. This massive increase in supply means much lower prices, it also means less need to import natural gas. Fracking will increase energy independence and energy security. It will also lead to natural gas being substituted for coal, which is a net win on all sorts of pollutants, including carbon dioxide. Natural gas is also an important chemical feedstock used in the

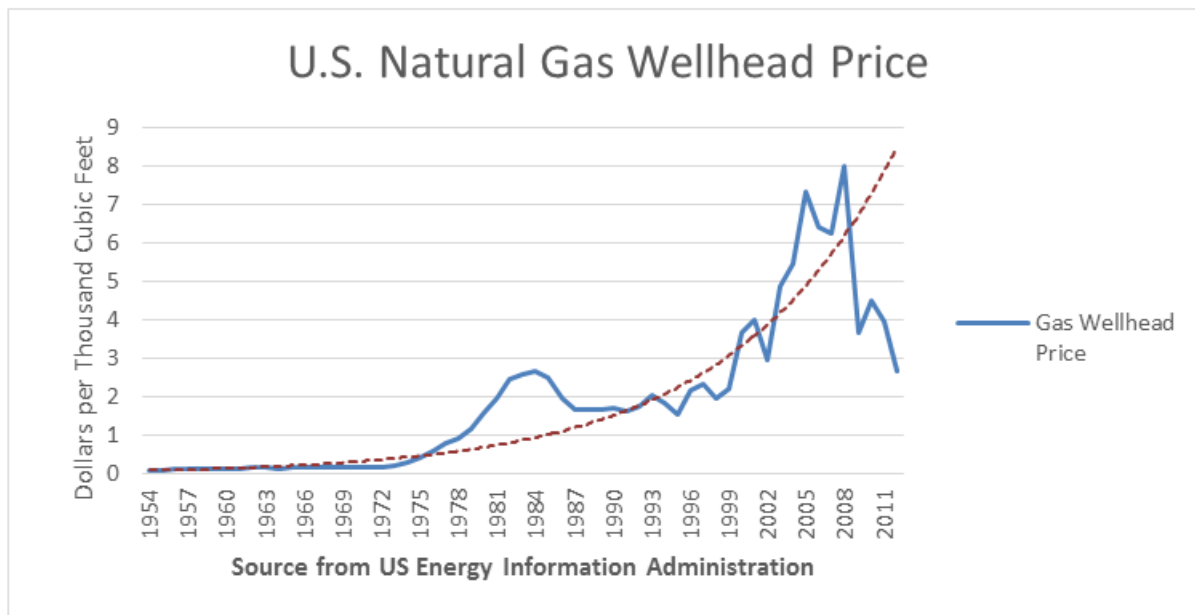

Figure 1.10: US natural gas wellhead price[15]

production of all manner of plastics and other chemicals with applications from consumer packaging to medicine. Since US natural gas is cheaper, the low priced feedstocks make US chemical producers cost-competitive relative to their foreign competitors. And also the new development supported 600,000 jobs in 2011[66].

However fracking requires lots of water and chemicals. These have to be trucked into sites and disposed of properly. Huge amount of water will needed and huge amount of wastewater will generated during the fracking process. Fracking has been associated with some tremors in some areas. There is limited understanding of this so far and it will limit fracking in some areas/regions. This appears to be rare and manageable in the aggregate. If wells are not properly capped, too much methane is vented – a bad greenhouse gas – negating the environmental benefit. This is also very manageable when wells are properly constructed. There are potential for cross-contamination of drinking water aquifers with fracturing chemicals or more likely, methane. The induced seismic activity from deep injection wells, and extend our reliance on fossil fuels[32].

1.3.2 Fracking

Introduction

Fracking is a process used to extract natural gas (and in some cases oil) from deep reserves in various rock formations below the surface. This process allows energy companies to extract natural gas and oil that was not previously attainable.

The fracking process involves pumping a mixture of water, sand and chemicals into a well

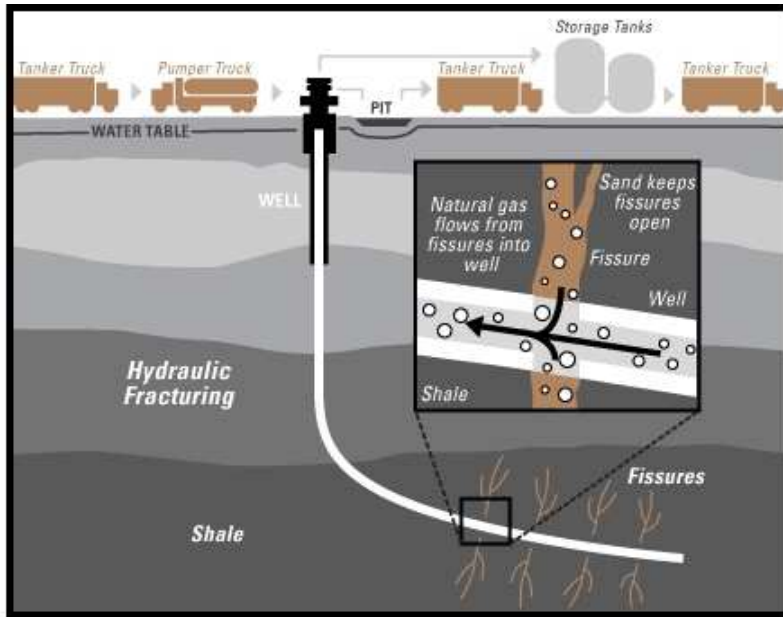

Figure 1.11: Hydraulic Fracturing (Fracking)[45]

at a high pressure, which fractures the surrounding rock formation and opens passages and allows the gas and oil to flow more freely. Once the well is developed, some of the fracking fluid is carried back to the surface with the gas and oil, while the rest remains in the ground.

Economic Benefits

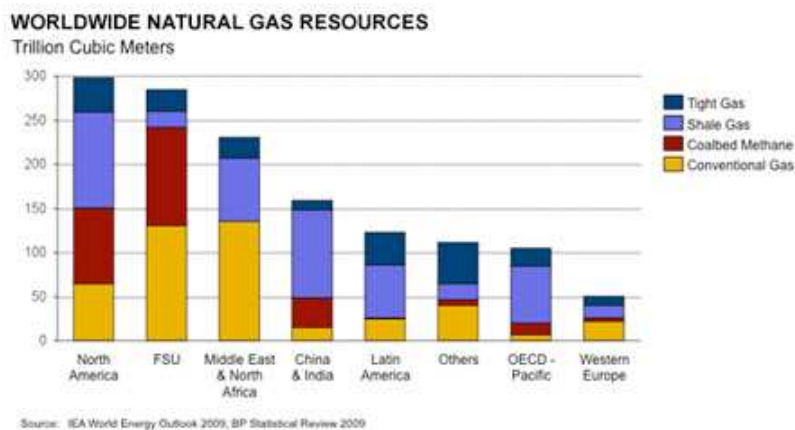

Figure 1.12: Worldwide Natural Gas Resources[102]

The technique is mainly used in three types of natural gas: Shale gas, Tight gas and Coalbed Methane (CBM). As we can see in Figure 2, most of natural gas resources are these

three types of natural gas.

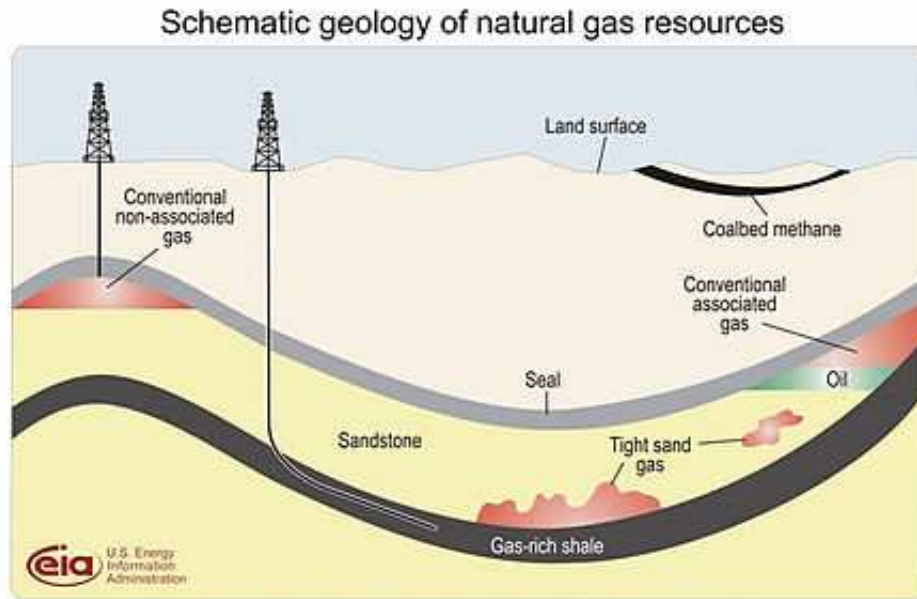

Figure 1.13: Schematic geology of natural gas resources[15]

Figure 1.12 shows us the distribution of natural gas underground.

Originally, the production rate of shale gas is pretty low due to its low pressure and low saturation. However, with Fracking and Horizontal drilling, the production rate of it has made a big increment. Similarly, Tight gas is natural gas produced from reservoir rocks with such low permeability that massive hydraulic fracturing is necessary to produce the well at economic rates.[74] For the CBM, Fracking has been used to accelerate removal of methane from coal seams ahead of underground mines.

Therefore, Fracking make a significant progress in natural gas extraction, which would bring great economic benefits.

Environment Impacts

The environment impacts include the potential contamination of ground water, risks to air quality, noise pollution, the potential migration of gases and hydraulic fracturing chemicals to the surface, the potential mishandling of waste, and the health effects of these.

Figure 15 represents the composition of fracking fluid. Most of the environment impacts, except the noise pollution and the geology impact, are come from the chemical additives in the fluid.

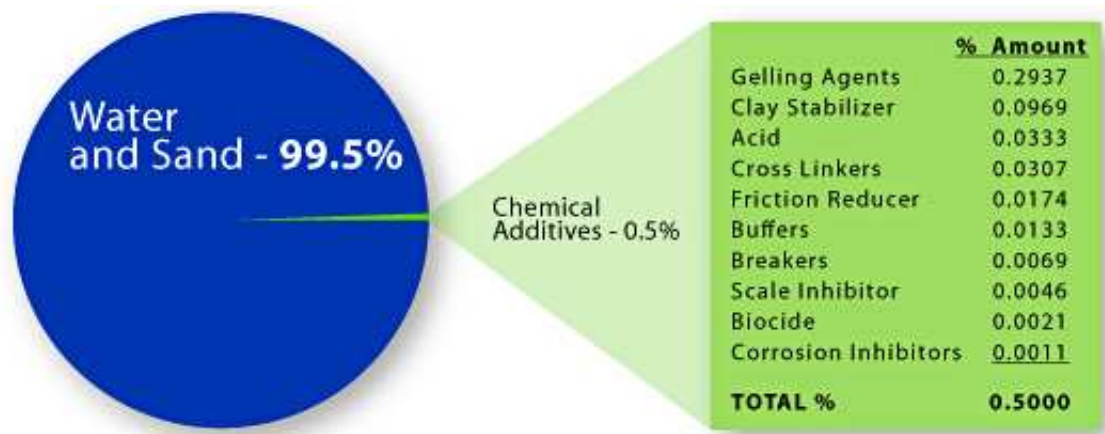

Figure 1.14: Composition of fracking fluid[5]

However, these chemical additives are the central part of the fluid and of the fracking technique. So these impacts are unavoidable now. There are many debates on them, and the anti-fracking movement is advocated by many organizations and nations, such as International Environmental Organizations and France.

Hence, the environment impact is the main problem in development of fracking. Another thing is that though fracking helps us extract gas from new resources, and more efficient, the reservation of natural gas is still limited. So we still need to explore other renewable and sustainable energy.

1.4 Nuclear Energy

1.4.1 Overview

Outline history of nuclear energy

The science of atomic radiation, atomic change and nuclear fission was developed from 1895 to 1945, much of it in the last six of those years. Over 1939-45, most development was focused on the atomic bomb. From 1945 attention was given to harnessing this energy in a controlled fashion for naval propulsion and for making electricity. Since 1956 the prime focus has been on the technological evolution of reliable nuclear power plants.

Nuclear power didn't go commercial and provide human beings with low-carbon electricity until early 1960s, where the technologies related to nuclear energy are well developed. Both kinds of reactor, PWR (Pressurized Water Reactor) and BWR (Boiling Water Reactor) were first set up commercially in the USA at the beginning of 1960s. The first fully commercial PWR, Yankee Rowe of 250 MWe, was designed by Westinghouse and started up in 1960 and operated to 1992. Meanwhile the first BWR, Dresden-1 of 250 MWe, designed by General Electric, was started up earlier in 1960. By the end of the 1960s, orders were being placed for

PWR and BWR reactor units of more than 1000 MWe.[23]

Consumption and Reserves

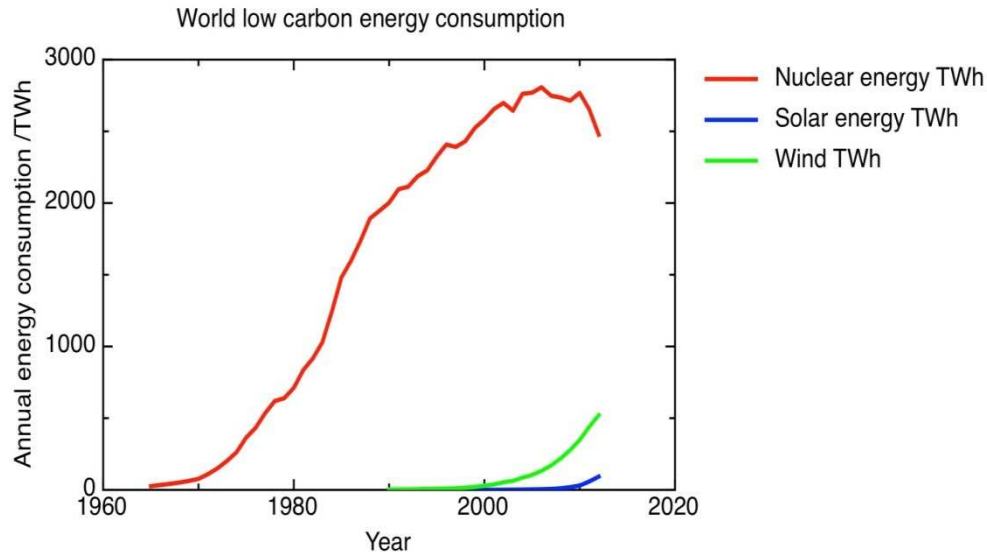

Figure 1.15: World low carbon energy consumption[81]

The graph is the case for nuclear consumption in last 60 years. Compared with the other two low-carbon electricity sources, nuclear energy played a big role in worlds total energy consumption, although more energy consumed directly in oil and gas.

Although nuclear generation has dropped significantly since the Fukushima nuclear disaster in 2011, the nuclear energy provides the world with a significant amount of low-carbon electricity and it cannot be replaced by renewables quickly in next few years. Therefore, the amount of nuclear generation might keep increasing in the future. According to the experience of the 1970s and 1980s, it will be possible to add significant capacity in a reasonable timescale.

Cost

The economics of nuclear power involves consideration of three aspects: capital cost, plant operating cost, and external cost.

1. Capital costs: include the cost of site preparation, construction, manufacture, commissioning and financing a nuclear power plant. Building a large-scale nuclear reactor takes thousands of workers, huge amounts of steel and concrete, thousands of components, and several systems to provide electricity, cooling, ventilation, information, control and communication. The estimate for a new nuclear plant is US\$ 5,339/kW.
2. Plant operating costs: include the costs of fuel, operation and maintenance (O&M), and a provision for funding the costs of decommissioning the plant and treating and disposing

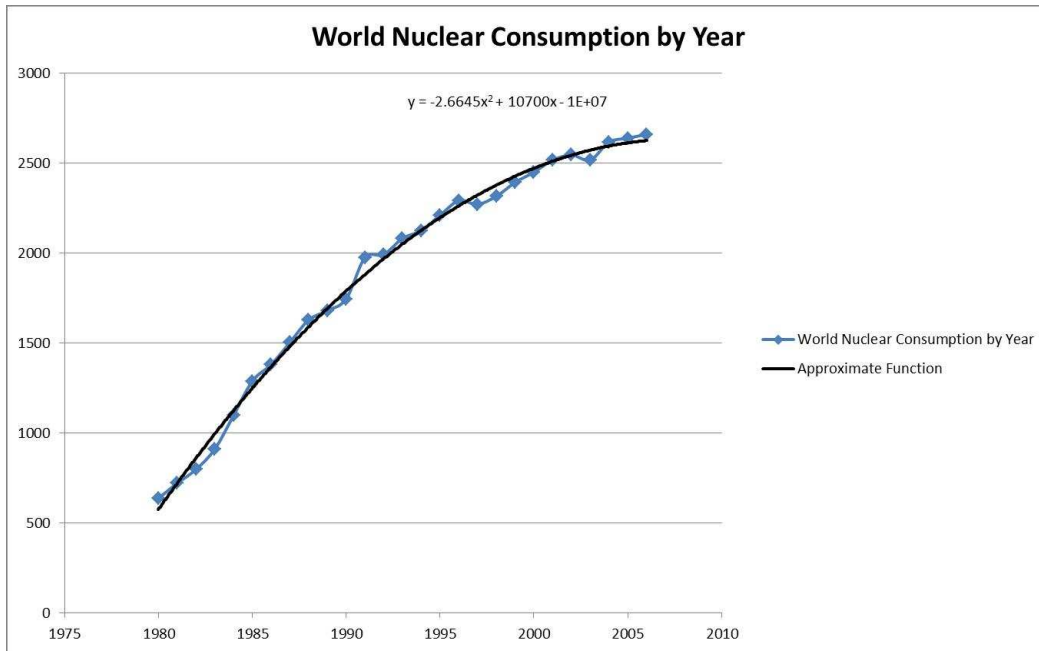

Figure 1.16: World Nuclear Consumption by Year[8]

of used fuel and wastes. The cost of fuel includes uranium, conversion, enrichment and fuel fabrication. And nuclear operator cost is \$1-3/MWh.

- External costs to society from the operation, which in the case of a nuclear power is usually assumed to be zero, could include the costs of dealing with a serious accident that are beyond the insurance limit and in practice need to be picked up by the government. Considering the Chernobyl accident and the Fukushima accident, the external cost may be a significant amount. But if we could find a way to keep the operator working safely, the external cost would be minimized.

According to these three aspects, the average cost of electricity generated by nuclear power is about 112.7\$/MW-h.[13]

1.4.2 Generation IV

The nuclear power industry has been developing and improving reactor technology for more than five decades and is starting to build the next generation of nuclear power reactors to fill new orders.

Several generations of reactors are commonly distinguished. Generation I reactors were developed in 1950-60s, and outside the UK none are still running today. Generation II reactors are typified by the present US and French fleets and most in operation elsewhere. So-called Generation III is the Advanced Reactors, though the distinction from Generation II is arbitrary. The first are in operation in Japan and others are under construction or ready to be ordered. Generation IV designs are still on the drawing board and will not be operational

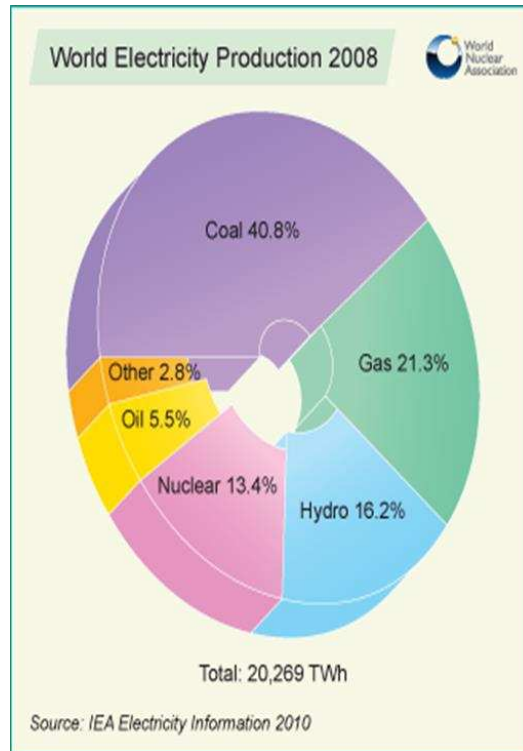

Figure 1.17: World Electricity Production by Year[24]

before 2020 at the earliest.

Nowadays, we have 6 technologies classified by the Generation IV International Forum, which are going to be discussed in this page. They are Very High Temperature Nuclear Reactor (VHTR), Supercritical Water-Cooled Reactor (SCWR), Molten Salt Reactor (MSR), Gas-Cooled Fast Reactor (GFR), Sodium-Cooled Fast Reactor (SFR), and Lead-Cooled Fast reactor (LFR). The VHTR, SCWR, and MSR are called thermal reactors and GFR, SFR, and LFR are called fast-neutron reactors.[25]

Very High Temperature Nuclear Reactor[71]

- General features:

1. Uses a graphite-moderated core with a once-through uranium fuel cycle, and uses helium or molten salt as the coolant.
2. The coolant exits the reactor at a high temperature, which enables a high thermal efficiency for electricity generation (according to Brayton cycle). The efficiency is greater than 50%.
3. The high temperature can serve as process heat for hydrogen production.

- Challenges

The very high operating temperature causes a challenge for the fuel and materials development, as well as safety under the transient condition

Supercritical Water-Cooled Reactor

- General features:

1. Uses supercritical water as the working fluid. Cooled with light water and moderated with light or heavy water.
2. Operate at a high pressure ($P > 22.1 \text{ MPa}$, supercritical).
3. Has a high thermal efficiency (about 45%) and considerable plant simplification.
4. With a low capital cost, the main mission of the SCWR is generation of low-cost electricity.

- Challenges

1. Higher pressure combined with higher temperature and also a higher temperature rise across the core result in increased mechanical and thermal stresses on vessel materials that are difficult to solve.
2. The coolant greatly reduces its density at the end of the core, resulting in a need to place extra moderator there.
3. Special start-up procedures needed to avoid instability before the water reaches supercritical condition.

Molten Salt Reactor

- General features:

1. The coolant is a molten salt mixture, which has a low pressure and high boiling point.
2. Operating at a low pressure improves safety and simplifies the design.
3. Molten salt reactors can run at high temperatures, yielding high efficiencies to produce electricity.

- Challenges

1. Need to operate an on-site chemical plant to manage core mixture and remove fission products.
2. Classical safety analysis is not well adapted to the MSFR.

Gas-Cooled Fast Neutron Reactor

- General features:
 1. Is a helium-cooled system operating with an outlet temperature of 850°C , . Therefore has a high thermal efficiency in a Brayton cycle.
 2. It features a fast-neutron spectrum and closed fuel cycle for efficient conversion of fertile uranium and management of actinides.
 3. Reduced volumes and radio toxicity of high level waste.
- Challenges
 1. The greatest challenge facing the GFR is the development of robust high temperature refractory fuels and core structural materials.
 2. High power density, low thermal inertia, poor conduction path and small surface area of the core conspire to prevent conduction cooling.

Sodium-Cooled Fast Neutron Reactor

- General features:
 1. The goals are to increase the efficiency of uranium usage by breeding plutonium and eliminating the need for transuranic isotopes ever to leave the site.
 2. Is cooled by liquid sodium. Sodium atoms are heavy, and therefore the neutrons lose less energy in collisions with sodium atoms.
- Challenges
 1. More effective fissioning of transuranic actinides by fast neutrons.
 2. Energy cost competitive with alternate future energy sources.
 3. To render the risk of installing SFR systems much lower than the risk of energy alternatives.

Lead-Cooled Fast reactor

- General features:
 1. The coolant is molten lead or lead-bismuth eutectic. The fuel is metal or nitride-based containing fertile uranium and transuranic
 2. With an outlet coolant at about 550 C , it has a high thermal efficiency.
 3. As no electricity is required for the cooling after shutdown, this design has the potential to be safer than a water-cooled reactor.

4. Liquid lead-bismuth systems can't cause an explosion and quickly solidify in case of a leak, further improving safety.
5. Lead is very dense, and therefore a good shield, against gamma rays

- Challenges

1. Lead and lead-bismuth are very heavy, requiring more structural support and seismic protection that increases building cost.
2. By leaking and solidifying, the coolant may damage the equipment.
3. Lead-bismuth produces considerable amount of polonium, a highly radioactive and quite mobile element. This can complicate maintenance and pose a plant contamination problem. Lead produces orders of magnitudes less polonium, and so has an advantage over lead-bismuth in this regard.

The U.S. Energy Information Administration indicates that as of 2012, fossil fuels account for 84 percent of U.S. energy consumption. These fuels are used in manufacturing and transportation and support the electrical and power systems of homes and businesses.

However, all of those energy sources have limits, the reserve for coal is 997,748 million short tonnes (905 billion metric tonnes), which equivalent to 4,416 billion barrels (702.1 km³) of oil, which will be exhaust in 129 years. The reserve for Oil is 1,119 billion barrels (177.9 km³) to 1,317 billion barrels (209.4 km³), which will be exhaust in 60 years. The reserve for natural gas is 6,1836,381 trillion cubic feet (175181 trillion cubic metres), which is equivalent to 1,161 billion barrels (184.6109 m³) of oil. Although due to fracking the reserve for natural gas has been increase dramatically it still will be exhaust in 71 years.

And also coal, natural gas and nuclear power all add pollutants to water that, if discharged into a lake or stream, can negatively impact water quality and harm wildlife. Energy generation from biomass presents similar concerns. Drilling geothermal wells can cause groundwater contamination if proper management practices are not observed. Wind and solar energy systems do not result in water pollution. (See References 5) Coal produces a solid waste called ash in addition to the pollution created during the mining process. Nuclear energy is another traditional system that results in large amounts of solid waste, which can take thousands of years to diminish. [Traditional Energy Sources]

At the same time it is becoming increasingly difficult to discover and exploit their new deposits. It is envisaged at known deposits of petroleum in our country will get exhausted by the few decades and coal reserves are expected to last for another hundred years.

Therefore it is urgent to find other sources in order to provide enough energy, clean energy and cheap energy for all people in the world.

Chapter 2

Renewable Energy

Due to the more and more severe energy shortage situation our human facing nowadays, development of renewable energy seems getting crucial. People found that renewable energy resources are great and generate much less harmful gradients than traditional energy. Resources such as solar energy, wind energy, hydropoweretc, has a great potential to solve the energy obstacles we are facing. In this section, different renewable energy resources and their development over these years will be discussed.

2.1 Solar Energy

Solar energy is energy from the sun that can be converted directly or indirectly into other forms of energy. It is a free and clean energy source that does not produce waste or pollution and is ecologically acceptable[59]. Solar energy drives climate and weather and supports all life on Earth, and it usually refers to photovoltaic solar thermal modules and concentrating solar thermal technologies that can convert Sun's energy into electricity or heat.[79]

In photovoltaic modules, solar radiation is directly converted into an electric current. PV devices can be used to power anything from small electronics such as calculators and road signs up to homes and large commercial business.[22]

Photovoltaic (PV) cells are made up of at least 2 semi-conductor layers. One layer contains a positive charge, the other a negative charge. Sunlight consists of little particles of solar energy called photons. As a PV cell is exposed to this sunlight, many of the photons are reflected, pass right through, or absorbed by the solar cell. When the negative layer of the photovoltaic cell absorbs enough photons, electrons are freed from the negative semiconductor material. Due to the manufacturing process of the positive layer, these freed electrons naturally migrate to the positive layer creating a voltage differential, similar to a household battery. When the 2 layers are connected to an external load, the electrons flow through the circuit creating electricity. Each individual solar energy cell produces only 1-2 watts. To increase power output, cells are combined in a weather-tight package called a solar module. These modules (from one to several thousand) are then wired up in serial and/or parallel with one another, into what's called a solar array, to create the desired voltage and am-

perage output required by the given project. Due to the natural abundance of silicon, the semi-conductor material that PV cells are primarily made of, and the practically unlimited resource in the sun, solar power cells are very environmentally friendly. They burn no fuel and have absolutely no moving parts, which make them virtually maintenance free, clean, and silent[38].

Solar thermal modules utilities the suns energy to heat water, then pumped into residential central heating.[15] Every solar water-heating system features a solar collector that faces the sun to absorb the sun’s heat energy. This collector can either heat water directly or heat a ”working fluid” that’s then used to heat the water. In active solar water-heating systems, a pumping mechanism moves heated water through the building. In passive solar water-heating systems, the water moves by natural convection. In almost all cases, solar water-heating systems work in tandem with conventional gas or electric water-heating systems; the conventional systems operate as needed to ensure a reliable supply of heated water[96].

As in concentrated solar thermal modules, sunlight is used to heat up a fluid, expect, in order to achieve high temperatures, the light beams are concentrated using mirrors. The hot fluid is then used to drive a conventional turbine to generate electricity. Current technologies for large-scale thermal power plants can be distinguished in the way they collect and concentrate solar radiation. As diffuse light can be focused, only locations with a high proportion of direct light will be suitable for this technology.

The average cost of solar PV generated electricity is \$156.9 per MWH and the average cost of solar thermal generated electricity is \$ 251.0 per MWH. However, compare to other source of energy, such as coal \$99.6 per MWH, Hydro \$88.9 per MWH, and wind 96.8 per MWH, it is still very expensive[19].

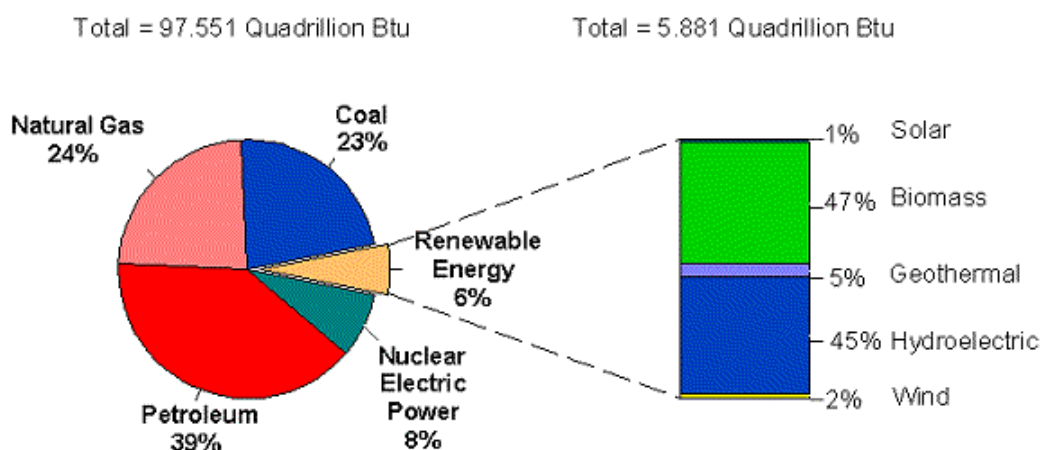

Figure 2.1: Percentage of solar in renewable energy[59]

Although solar energy is used in many applications and it is renewable energy source, it

cant be easily exploited in all areas. The picture shows that solar energy is still a very tiny fraction on global world energy market. Solar energy has these general problems: huge oscillation of radiation intensity and large investments costs. However, solar energy’s reduction in unit costs has yielded its growth rates and therefore solar energy has potential to become very important energy source.[59]

Solar energy, radiant light and heat from the sun, has been harnessed by humans since ancient times using a range of ever-evolving technologies. Solar energy technologies include solar heating, solar photovoltaic, solar thermal electricity and solar architecture, which can make considerable contributions to solving some of the most urgent problems the world now faces. The Earth receives 174 petawatts (PW) of incoming solar radiation at the upper atmosphere. Approximately 30% is reflected back to space while clouds, ocean and landmasses absorb the rest[14]. Much of the suns energy is reflected (by clouds or reflective surfaces like snow) or absorbed before it hits the earths surface.

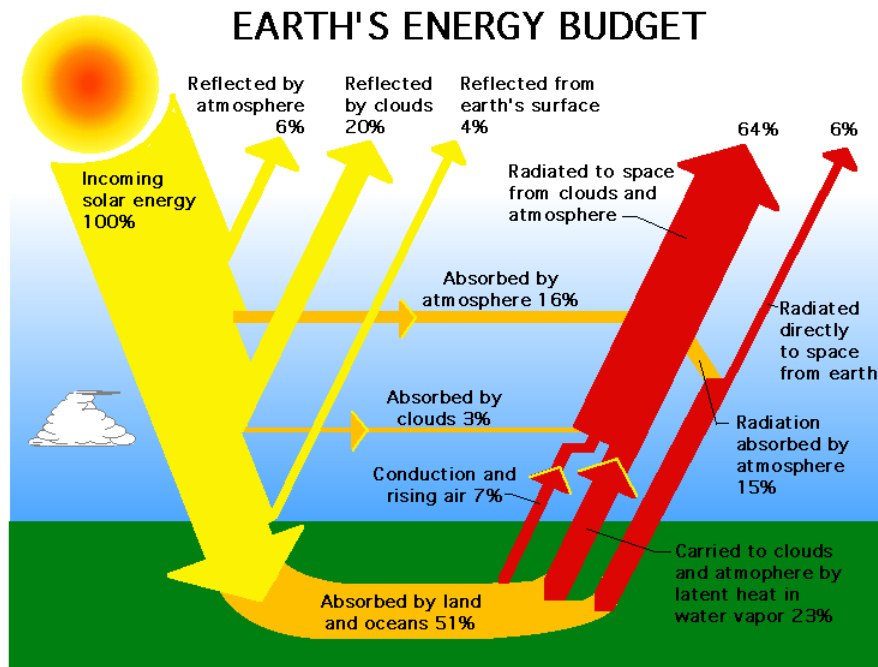

Figure 2.2: Earth’s Energy Budget[83]

The use of solar energy has improved a lot during the last two decades. The number of solar panels shipped increases from 3645 in 1990 to 10511 in 2009, and the price per square foot has decreased from \$2.90 in 1990 to \$1.94 in 2009. Although the price of solar energy has decreased a lot, compare to other energy sources such as natural gas it is still very expensive[83]

Solar hot water is quite different from solar photovoltaic. A solar collector concentrates the suns rays to heat water, which makes a closed loop through the heating tank. The hot water is passed into a tank that contains a heat exchanger (usually used in conjunction with the hot water heater already installed in the home). As heat is exchanged in the tank, the

water is pumped back up to the solar collector (determined by a controller unit). Cold water that passes through the tank heats up and makes its way to your tap[51].

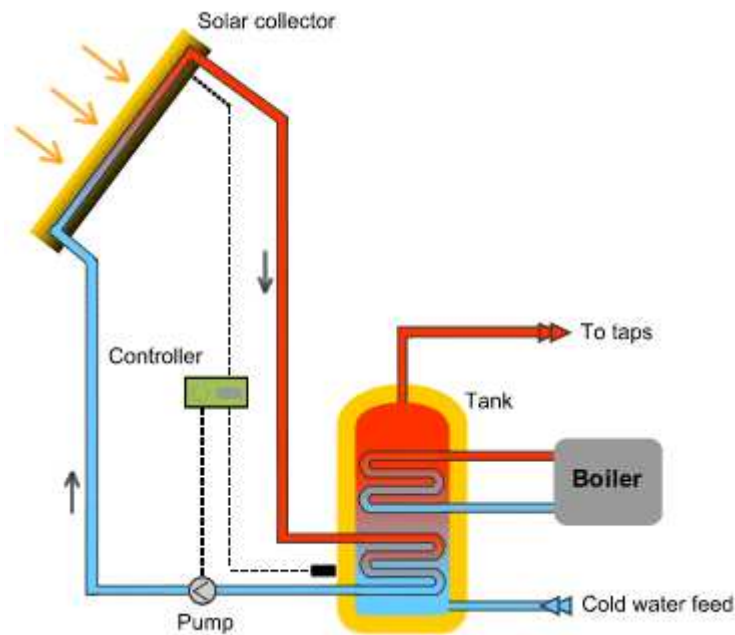

Figure 2.3: Solar Collector System[83]

Meeting the worlds ever-growing energy demands in an environmentally responsible and sustainable manner is one of the most pressing issues facing us. Solar energy sunlight is an abundant, clean, safe and free resource, providing on average approximately 1,000 watts of power per square meter to Earths surface on a sunny day. In fact, the total amount of solar energy that hits Earth in just two hours is more than enough to meet current global energy consumption for an entire year.

When the sun shines, we can store the electricity generated by solar cells or steam-driven turbines by using batteries (technically energy stored as electrochemical potential) or super-capacitors (energy stored in an electric field, due to the spatial separation of positive and negative charges). Then we can release electrical energy when it is cloudy or at night.

There are at least two other ways to store solar energy for use later. First, the thermal energy of concentrated sunlight can be stored in the heat capacity of a molten salt (the liquid form of an ionic compound like sodium chloride) at a high temperature. When electricity is needed later, heat is transferred from the molten salt to water, using a heat exchanger to generate steam to drive a turbine.

A second method of harnessing and storing solar energy is to employ sunlight to produce a fuel. For example, a photoelectrochemical cell uses solar energy to split water into hydrogen and oxygen gases, which can be stored as fuels. These gases are then recombined to generate

electricity in a device known as a fuel cell.[111]

A fuel cell is a device that generates electricity by a chemical reaction. Every fuel cell has two electrodes, one positive and one negative, called, respectively, the anode and cathode. The reactions that produce electricity take place at the electrodes.

Every fuel cell also has an electrolyte, which carries electrically charged particles from one electrode to the other, and a catalyst, which speeds the reactions at the electrodes.

Hydrogen is the basic fuel, but fuel cells also require oxygen. One great appeal of fuel cells is that they generate electricity with very little pollution much of the hydrogen and oxygen used in generating electricity ultimately combine to form a harmless byproduct, namely water.

Although there are abundant quantities of hydrogen in the universe, very little of it here on Earth is in a freely available form - it is usually present in a compound with other elements. To use the hydrogen, it must be extracted from these compounds. Most industrial hydrogen is currently produced from oil or gas, by reforming of the hydrocarbon feedstock to produce synthesis gas (syngas), primarily a mixture of hydrogen and carbon monoxide. The hydrogen must then be separated from the other gases; this is usually accomplished by pressure swing adsorption. This process requires fossil fuel and produces carbon dioxide and is therefore not a sustainable practice. However, hydrogen can also be produced in a similar way from renewable sources such as biomass. The ideal is to produce hydrogen so that life cycle carbon emissions are zero, which can be done by using renewable energy (like wind or solar) to power an electrolyser to split water into hydrogen and oxygen. The hydrogen can be compressed, stored and transported from the site of production to the point of use. Running a fuel cell on this hydrogen produces zero carbon emissions[55]

The purpose of a fuel cell is to produce an electrical current that can be directed outside the cell to do work. Because of the way electricity behaves, this current returns to the fuel cell, completing an electrical circuit. The chemical reactions that produce this current are the key to how a fuel cell works.

In general terms, hydrogen atoms enter a fuel cell at the anode where a chemical reaction strips them of their electrons. The hydrogen atoms are now "ionized," and carry a positive electrical charge. The negatively charged electrons provide the current through wires to do work. If alternating current (AC) is needed, the direct current output of the fuel cell must be routed through a conversion device called an inverter.

Oxygen enters the fuel cell at the cathode and, in some cell types; it there combines with electrons returning from the electrical circuit and hydrogen ions that have traveled through the electrolyte from the anode. In other cell types the oxygen picks up electrons and then travels through the electrolyte to the anode, where it combines with hydrogen ions.

The electrolyte plays a key role. It must permit only the appropriate ions to pass between the anode and cathode. If free electrons or other substances could travel through the elec-

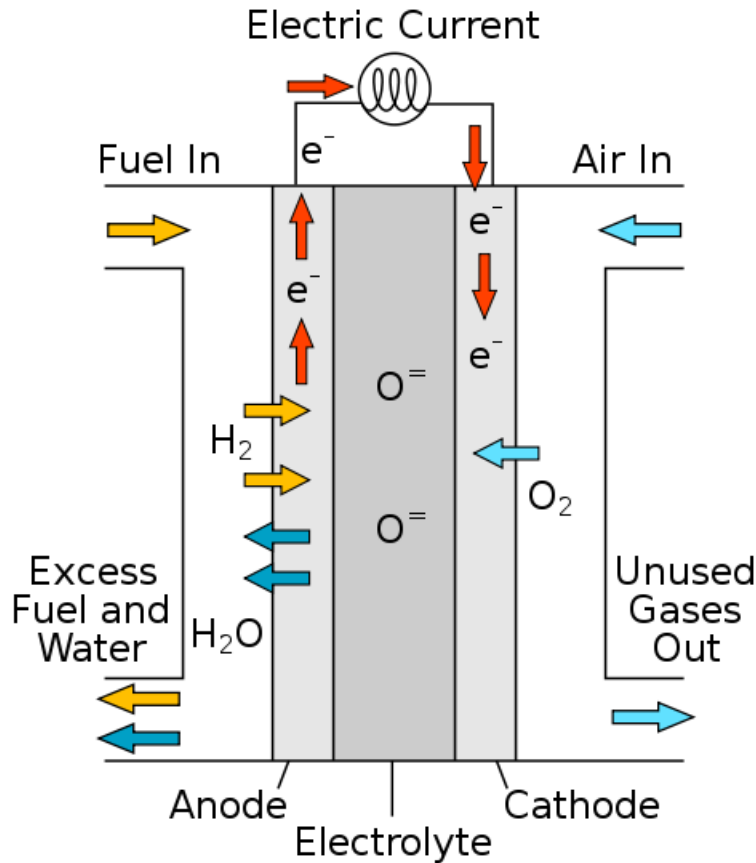

Figure 2.4: How fuel cell works[55]

trolyte, they would disrupt the chemical reaction.

Whether they combine at anode or cathode, together hydrogen and oxygen form water, which drain from the cell. As long as a fuel cell is supplied with hydrogen and oxygen, it will generate electricity.[65]

The graph above shows that the cost of automotive fuel cells has been reduced by more than 30% since 2008 and more than 80% since 2002 (from \$275/kW in 2002 to \$49/kW in 2011, based on projections to high-volume manufacturing).[64]

However the high capital cost for fuel cells is by far the largest factor contributing to the limited market penetration of fuel cell technology. In order for fuel cells to compete realistically with contemporary power generation technology, they must become more competitive from the standpoint of both capital and installed cost (the cost per kilowatt required to purchase and install a power system).

In the stationary power market, fuel cells could become competitive if they reach an installed cost of \$1,500 or less per kilowatt. Currently, the cost is in the \$4,000+ range per

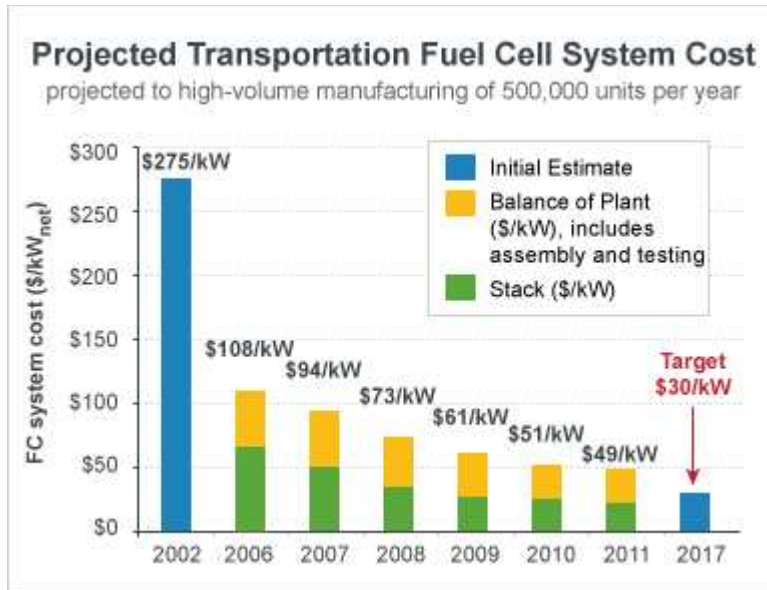

Figure 2.5: Projected Transportation Fuel Cell System Cost[65]

kilowatt. In the automobile sector, a competitive cost is on the order of \$60 - \$100 per kilowatt, a much more stringent criterion.

The high capital cost (on a \$/kW basis) today has led to a significant effort focused cost reduction. Specific areas in which cost reductions are being investigated include:

1. Material reduction and exploration of lower-cost material alternatives
2. Reducing the complexity of an integrated system
3. Minimizing temperature constraints (which add complexity and cost to the system)
4. Streamlining manufacturing processes
5. Increasing power density (footprint reduction)[34]

2.2 Wind Energy

As an alternative to fossil fuels, wind power is plentiful, renewable, widely distributed, clean and produces no greenhouse gas emissions[62]. The effects on the environment are generally less problematic than those from other power sources. In 2010 wind energy production was over 2.5% of total worldwide electricity usage, and growing rapidly at more than 25% per annum.

Wind energy can be converted into a useful form of energy in several ways, such as using wind turbines to make electrical power, windmills for mechanical power, and wind pumps for water pumping or drainage. Here in this report, the focus will be mainly on wind turbines.

Hundreds of individual wind turbines will be contained in large wind farms and they are connected to the electric power transmission network. Offshore wind farms will encounter less visual impact, thus it is steadier and stronger than on land. However, more money will be needed for the construction and maintenance. As of 2011, offshore wind farms were at least 3 times more expensive than onshore wind farms of the same nominal power[68] but these costs are expected to fall as the industry matures[84]. Small onshore wind farms provide electricity to isolated locations. Many of the largest operational onshore wind farms are located in the US.

Worldwide there are now over two hundred thousand wind turbines operating, with a total nameplate capacity of 282,482MW as of end 2012[42]. The European Union alone passed some 100,000MW nameplate capacity in September 2012[113], while the United States surpassed 50,000 MW in August 2012 and China passed 50,000 MW the same month[2][109]. China has been rapidly expanding its wind installations in the late 2000s and passed the U.S in 2010 to become the world leader. Referring to Table 1 in Appendix for more detail.

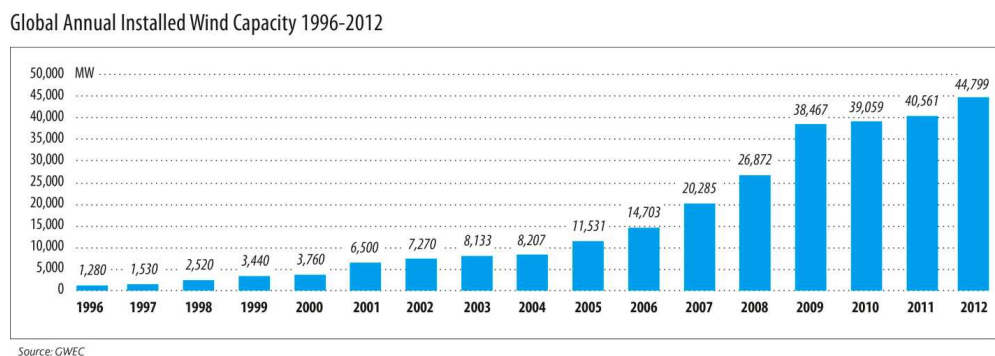

Figure 2.6: Global Annual Installed Wind Capacity 1996-2012 [6]

The average annual growth in new installations was around 27.6 percent [112] between 2005 and 2010. In the forecast to 2013 the expected average annual growth rate is 15.7 percent [112][21]. Wind power market penetration is expected to reach 3.35 percent by 2013 and 8 percent by 2018 [112][21]. Several countries have already achieved relatively high levels of penetration, such as 28% of stationary (grid) electricity production in Denmark (2011)[106], 19% in Portugal[7], 16% in Spain[101], and etc. As of 2011, 83 countries around the world were using wind power on a commercial basis[58].

Wind turbines reached grid parity in some areas of Europe in the mid-2000s, and in the US around the same time. Falling prices continue to drive the levelized cost down. Overall, a significant amount of the wind power resource in North America would still remain above grid parity due to the long transmission distances involved. Wind power has low ongoing costs, but a moderate capital cost. The marginal cost of wind energy once a plant is constructed is usually less than 1-cent per kWh[44]. This cost has reduced as wind turbine technology improved. There are now longer and lighter wind turbine blades, improvements in turbine performance and increased power generation efficiency. Also, wind project capital and main-

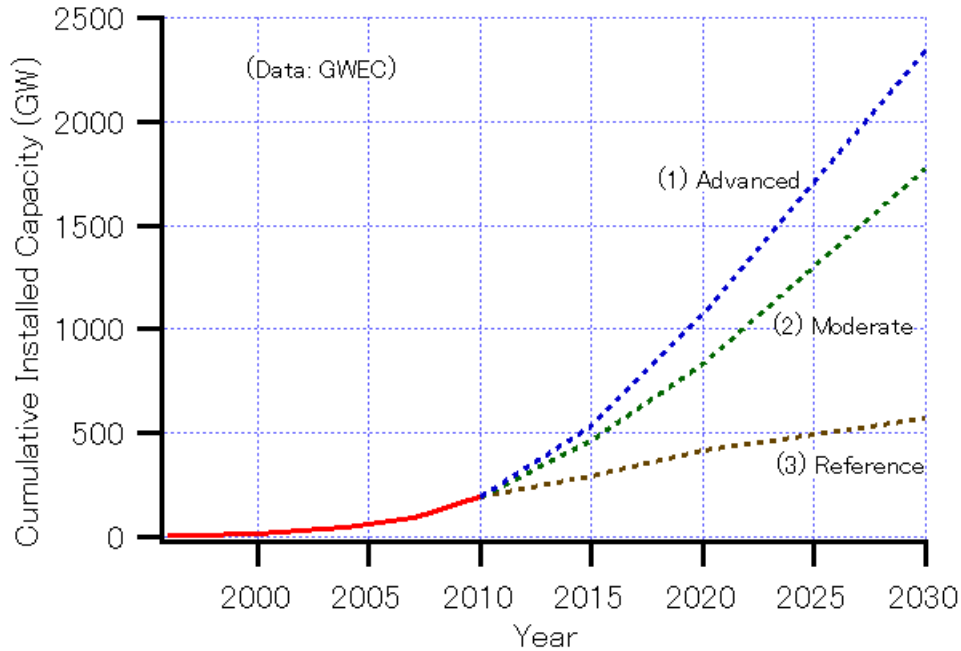

Figure 2.7: Cumulative Installed Capacity Forecast[94]

tenance costs have continued to decline [104].

However, cost figures can differ substantially due to factors such as the cost of the construction of the turbines and transmission facilities, estimated annual production, and etc. According to the 2011 report by American Wind Energy Association, it is said wind power cost has drop to the range of 5 to 6 cents per kilowatt-hour recently[12]. The monetary cost per unit of energy produced is similar to the cost for new coal and natural gas installations[54].

Regarding the wind turbine efficiency, first of all wind power generation depends on how fast wind is blowing. The kinetic energy of a mass in motion is $E = 1/2 * m * v^2$, where v is the velocity and m is the mass. Power equals the rate of change of energy, thus $P = dE/dt = 1/2 * v^2 * dm/dt$, where the mass flow rate $dm/dt = \rho Av$, where ρ is the air density and A is the swept area of wind turbine. Therefore, power $P = 1/2 * \rho A v^3$. From the derived equation above, the power available from the wind varies as the cube of the wind speed, which means twice the wind speed means eight times the power. This is the main reason that the sites of wind farms need to be selected carefully. If wind speed is too low or too high, the turbine cannot generate electricity. This makes wind electricity generation variable and intermittent. The intermittency of wind seldom creates problems when used to supply up to 20% of total electricity demand [37], but as the proportion increases, a need to upgrade the grid, and a lowered ability to supplant conventional production can occur[125]. If the wind speed is about 5m/s, there is not sufficient power in the wind to be useful. Strong gusts, however, do provide extremely high levels of power, but probably the wind turbine will be damaged. Thus, a site with steady winds is more ideal.

There is an optimum amount of power to extract from a given swept area. Albert Betz[117],

a German physicist, concluded in 1919 that no wind turbine can convert more than 59.3% of the kinetic energy of the wind into mechanical energy. This is also known as the Betz Limit or Betz Law. In other words, the theoretical maximum power efficiency of any design of wind turbine is 0.59. C_{pmax} is denoted as 0.59. However, C_p is not a static value. It varies with the tip speed ratio[122]of the turbine, as $\lambda = \frac{Bladetipspeed}{WindSpeed}$, where blade tip speed = $\frac{rotationalspeed(rpm)*\pi*Diameterofblades}{60}$. Thus C_p can be assumed to be a function of tip speed ratio. A plot of the variation of the power coefficient with variations in the tip speed ration is listed below:

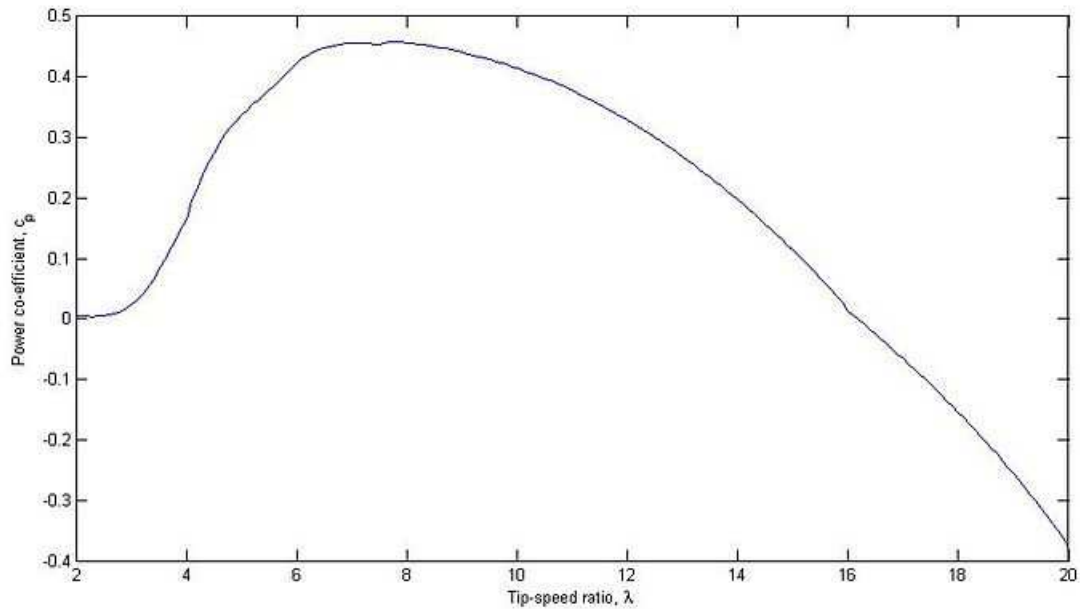

Figure 2.8: Tip-speed ratio Vs. Power Coefficient[46]

From the above plot, turbine designers typically compromise on tip speed ratios in the region of 7-10 to achieve a better coefficient.

As the design the number of blades of wind turbines, the principle is the less and narrower blades the better. Here solidity is being defined as the total blade area as a fraction of the total swept disc area. As for a given tip speed, there is an optimum solidity. If more number of blades is used, the narrower have each blade to be. Overall would cause the problem that it is difficult to build blades, which are strong enough if they are too thin, or more cost is needed for selecting more expensive materials. Besides, from the aesthetics point of view, three-bladed turbines are less visually disturbing than one-or two-bladed designs.

Like aeroplane wing, wind turbine blades generating lift due to their shape. The more curved side of wind turbines generate low air pressures while high pressure on the other side, thus result in a lift force perpendicular to the direction of flow of the air. The lift force increases as the increasing angle of attack. However, once the angle of attack reaches its

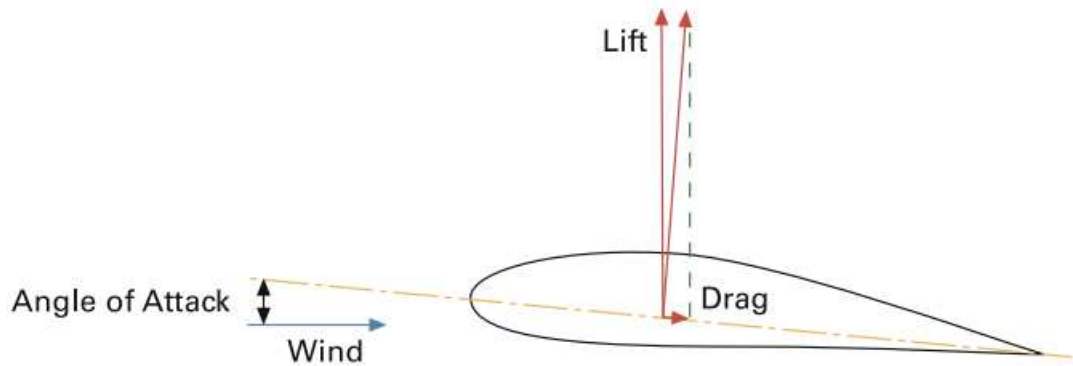

Figure 2.9: Airfoil aerodynamics[46]

optimum, the blade stalls and the lift decreases again, at the same time, a force called drag, which is parallel to the wind flow, increases dramatically. Therefore the blade reaches its maximum life/drag ratio at an angle slightly less than the maximum lift angle.

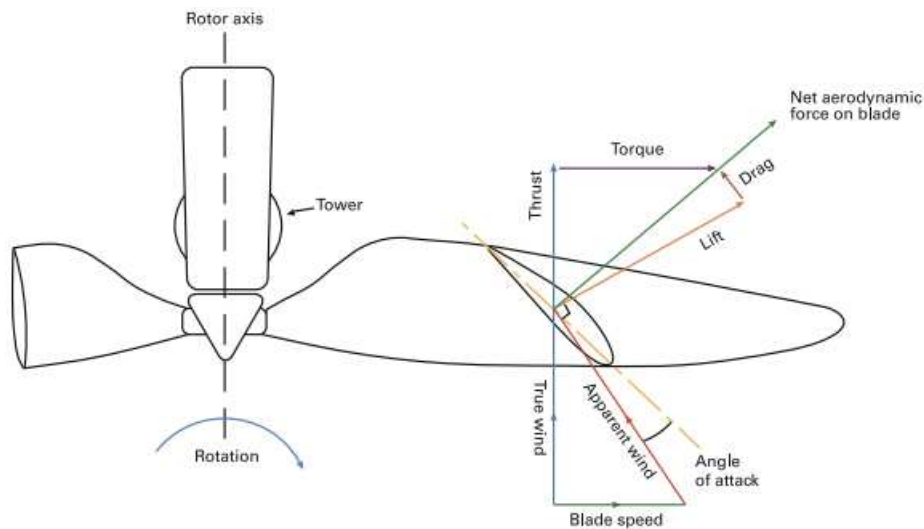

Figure 2.10: Net Aerodynamic force on blade[46]

When the blades are not stationary, the wind is blowing from a different angle. This is called apparent wind, which is the vector sum of the true wind and the blade speed. There's a fairly narrow window of apparent wind direction, in which a lifting airfoil will operate efficiently. It is the most desirable that the flow along both sides is smooth and remains attached to the blade surface. If it detaches, it will generate terrible drag and lost lift.

These conditions are known as stalling (attack angle too steep) and luffing (attack angle too shallow.)

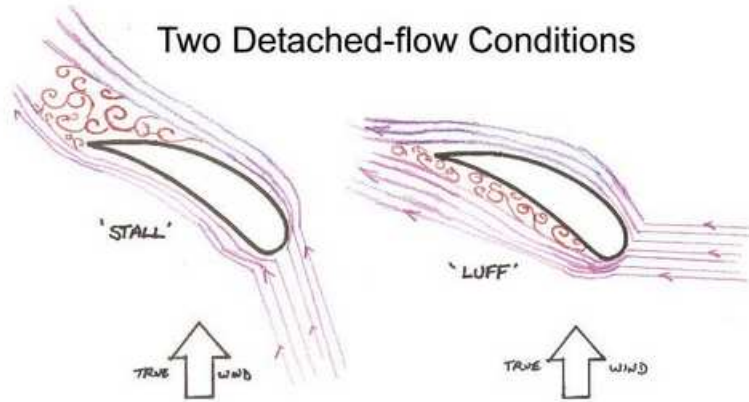

Figure 2.11: Two Detached-flow Conditions[46]

The apparent wind angle will be larger when it gets closer to the tip of the blade, resulting in the faster the blade is moving. Therefore, typically the blades must be built with a twist around 10-20 degrees along its length from root to tip to maintain optimum angle of attack of attack.

The thickness increases towards the root to take the structural loads, in particular the bending moments. If loads weren't important, then in general, thinner blades provide better life/drag ratio. Usually its thickness might be only 10-15% of its length across the blade.

The planform shape gets narrower to towards the tip to maintain a constant slowing effect across the swept area. This ensures that none of the air leaves the turbine too slowly (causing turbulence), yet none is allowed to pass through too fast (which would represent wasted energy).

It is very crucial when coming to the question of choosing a desirable wind farm location. The general principle is that the location has to be a place providing steady and intense wind resource, as well as minimizing the disturbance caused to human life.

When choosing a wind turbine location, the most obvious factor to concentrate is the wind resource. There is a wide range of options to determine the wind resource of the site. First, nature itself can help us to find suitable sites. The permanent flagging of trees, and not the temporary bending in the wind can show us the prevailing wind direction and is a good indicator for the strength of the wind. However, using this common sense as the only tool is of course insufficient due to its involved uncertainty. Wind speed measurements are required in order to estimate the energy yield on-site. The measurement period must be one year or more to avoid any seasonal bias.

Under specific conditions, wind turbines are designed specifically. For example, heavy-duty versions of wind turbines are designed for very complex sites with high wind speeds, which are sturdier but also more costly. Besides wind speed of sites, another most important

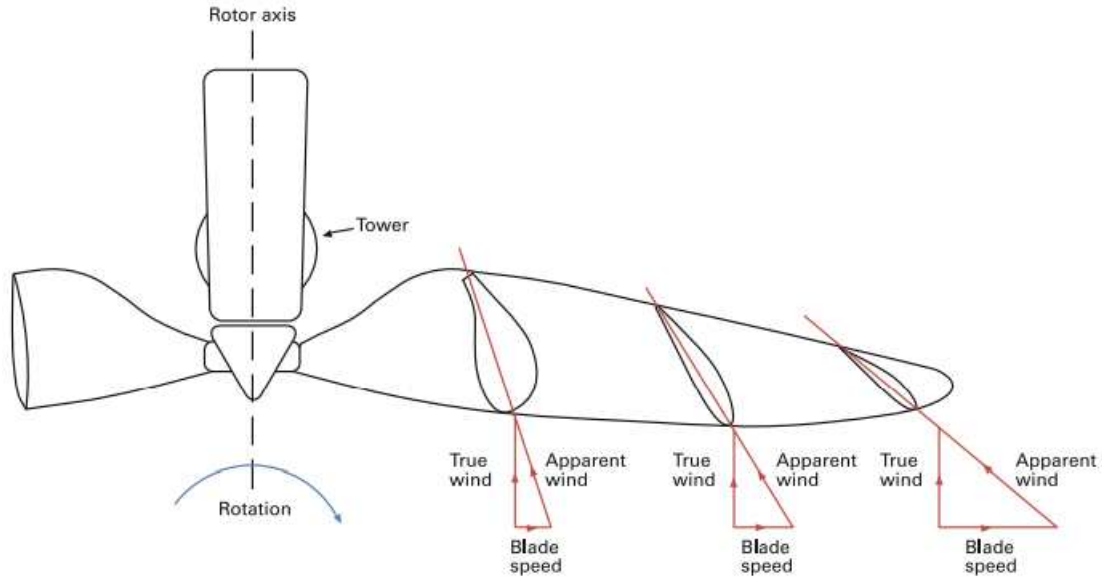

Figure 2.12: Angle of Twist[46]

parameter is turbulence intensity, which means how much the wind varies within 10 minutes. They are two sources of turbulence, one is generated by the terrain feature such as hills, forests, etc., called ambient turbulence; the other is generated by the neighboring wind turbines, called wake-induced turbulence. Avoiding critical terrain features can reduce ambient turbulence. However, wake-induced turbulence has far more impact than the ambient turbulence. Generally, the distance between wind turbines in prevailing wind direction should be a minimum of the equivalent of five rotor diameters. The spacing inside a row perpendicular to the main wind direction should be a minimum of three rotor diameters.

Another parameter is the flow inclination of a site. Location such as forest and hills should be avoided because the wind might hit the rotor not perpendicular but at an angle when wind turbines are to be placed on steep slopes. A large in-flow angle will reduce the energy production.

Several other planning constraints need to be taken into account. It would be less intrusive if the layout can follow the shape of terrain. Sites are better distant to people to reduce the noise impact. These accepted levels vary from country to country. Placing wind turbines in a transmission corridor should be avoided due to the electro-magnetic interference.

Below is the map showing wind projects locations distribution across US:

The map shows total 1137 wind project locations are in service with an installed cumulative wind power capacity of 60,688MW. 13 wind project locations are under construction. These locations will add an additional 738 MW of wind power capacity. This map contains 1295 total wind farm locations, including: in service, under construction and proposed loca-

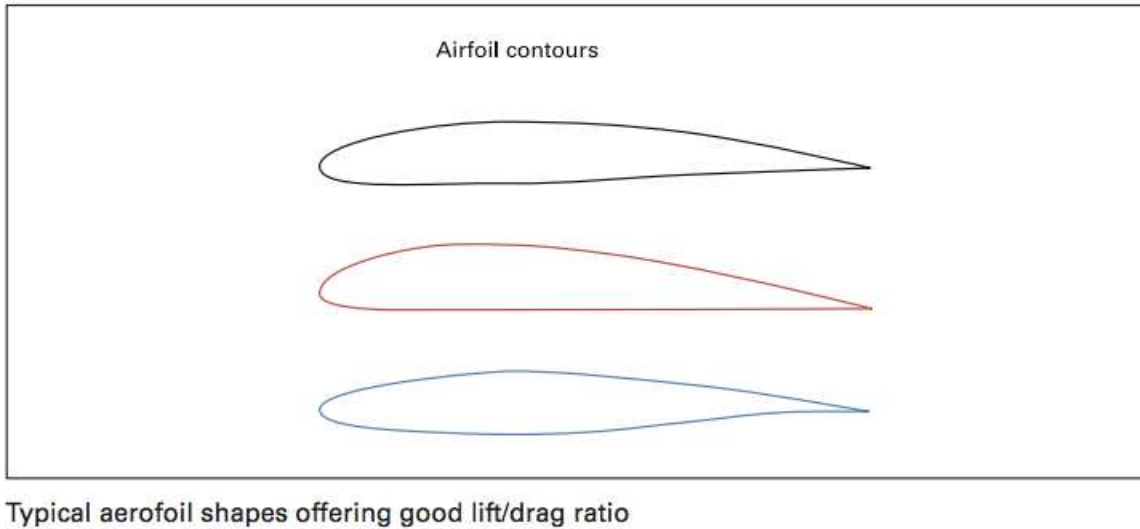

Figure 2.13: Typical Airfoil shapes[46]

tions. All locations have a combined wind power capacity with potential for generating up to 87624 MW.

The Alta Wind Energy Center in California is the world's largest wind farm at 1320 MW capacity. It consists of 490 wind turbines manufactured by General Electric, and Vestas. In 2012 it surpassed the Roscoe Wind Farm in Texas. Please see the Appendix for the list of large wind farms in US.

Wind turbines manufactured today have power ratings ranging from 250 watts to 7 MW. A single 1MW turbine on land can provide enough electricity to power 225 to 300 households. A single 1MW turbine in an offshore wind farm, where the wind blows harder and more consistently, can power more than 400 households. An onshore wind turbine with a capacity of 2.5-3MW can produce more than 6 million KWh in a year. The average U.S. household consumes about 10,000kWh of electricity each year. Thus 6 million kWh can provide approximately 600 households. Now as mentioned above, all locations have a combined wind power capacity with potential for generating up to 87624 MW. If assuming these installed wind turbines with capacity of 2.5-3MW, this total 87624 can provide total approximately 17,524,800 households. The number of household in US is total 114,800,000. Therefore, about 15% of the total households can use electricity generated by wind power. Noted, the above calculation is assumed in an ideal condition. The real situation, the percentage will be much less than 15%.

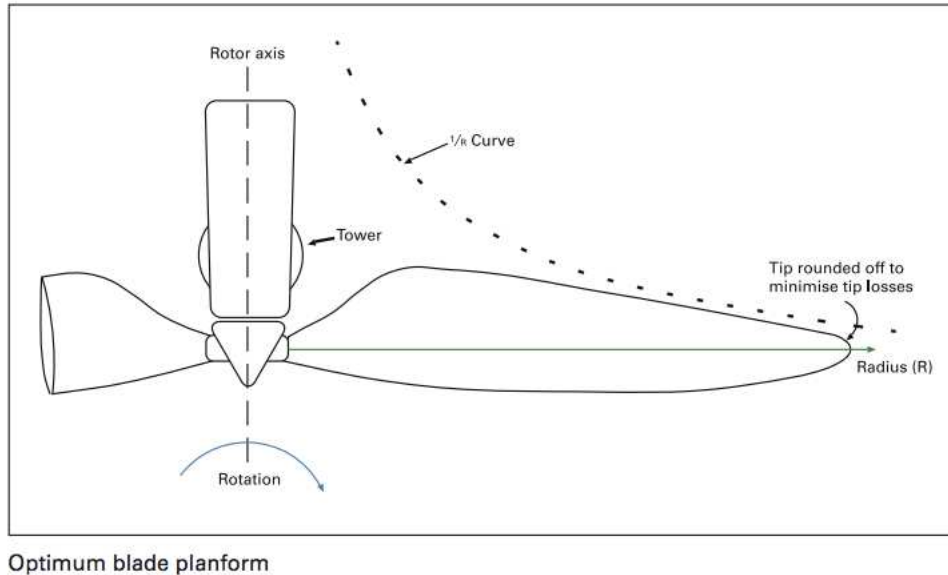

Figure 2.14: Optimum Blade Planform[46]

2.3 Biofuel

2.3.1 Overview

Biofuel is a fuel that contains energy from geologically recent carbon fixation. These fuels are produced from biomass, which refers to recently living organisms, most often referring to plants or plant-derived materials. Two main biofuels are Bioalcohols and Biodiesel. Both of them are used as transportation fuel. Thus now the main function of biofuel is to substitute some oil in transportation as a renewable energy.

Advantages and Disadvantages

- Advantages

1. Compared with traditional fossil fuels:
 - (a) Renewable
 - (b) More environmental
 - (c) Some biofuels are less expensive than fossil fuels
2. Compared with other renewable energy
 - (a) Easy for storage and transportation.
 - (b) Less expensive

- Disadvantages

1. Biofuel production consumes food and takes many lands. It causes the food VS fuel debate



Figure 2.15: Wind farms Location distribution[49]

2. Biofuel does not actually reduce the carbon emission. Also the productions of the biofuel are mostly from chemical industry, and the process of them also causes some illusions.

Prospect

Below is a figure that shows us the global production of biofuel in recent years.

We can see that there is a quickly increasing between 2002 and 2010, and the increment slow down after then. In 2012 it even became decreasing.

I think the reason is from the change of oil price. There was also a high-speed increasing of oil price between 2002 and 2010. The high price of oil made people find other energy. And biofuel is almost the only thing that can replace oil in transportation now. Thus it increased the production of biofuel. Though the oil price goes stable nowadays, it would increase in the future. The main problem is the food vs. fuel debate. However, it looks like that the second-generation biofuel solve these problems. Thus the biofuel has a bright future.

2.3.2 Algae Fuel

Algae fuel or algal biofuel is an alternative to fossil fuel that uses algae as its source of natural deposits.

From the figure above we can see that algae-fuel is a renewable and sustainable energy. The glycerin products in the cycle can be used as lube.

Also it has some advantages compared with other biofuels:

1. Do not take fields for food

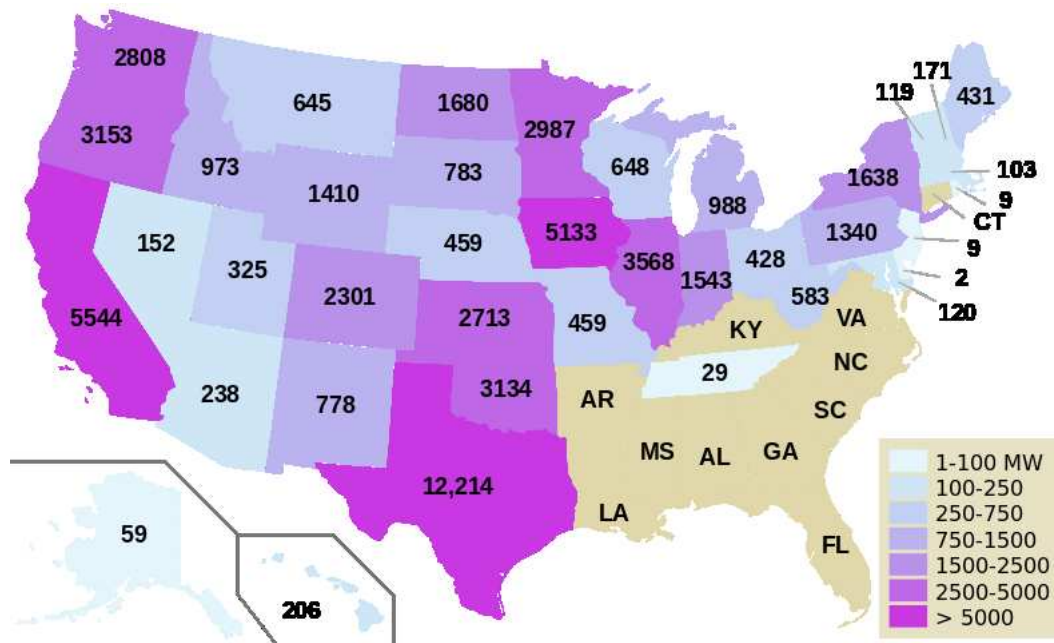

Figure 2.16: Combined wind power capacity according to states[124]

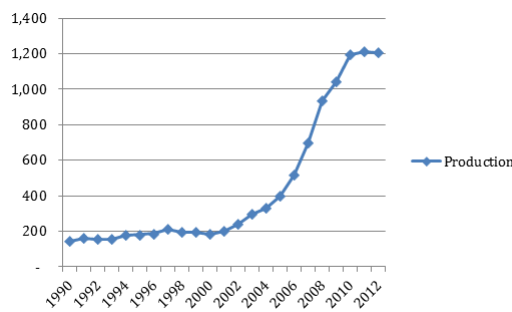

Figure 2.17: Global biofuel production from 1990 to 2012[33]

2. Absorb CO₂ during the cycle, reduce the CO₂ emission.
3. As we can see in Figure 2.19, it has a much higher productivity potential than crop-based biofuels.

The main challenge of the algae fuel is the high cost during the production. As we can see in figure 2.20, the algae fuel cost 10–20 per gallon, much higher than the gasoline, which is about \$3.5 per gallon.

In the figure, OP stands for open ponds and PBR stands for the photobioreactors. The difference between

Crop	Oil Yield Gallons/acre
Corn	18
Cotton	35
Soybean	48
Mustard seed	61
Sunflower	102
Rapeseed/Canola	127
Jatropha	202
Oil palm	635
Algae (10 g/m ² /day at 15% TAG)	1,200
Algae (50 g/m ² /day at 50% TAG)	10,000

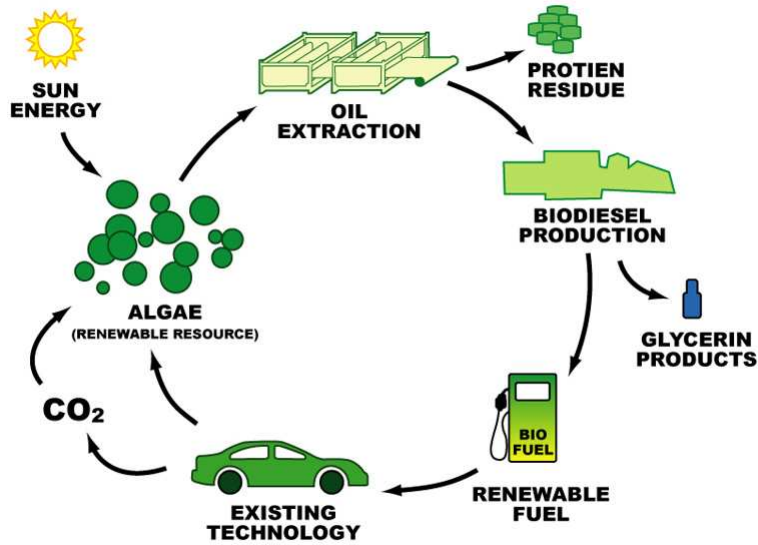

Figure 2.18: Algae fuel cycle[86]

them is that open ponds have low cost, but it need to face some challenges. The key challenges for algae cultivation in open ponds involve contamination, light penetration and water evaporation.

The main goal of developing algae fuel is to reduce the cost. If it can have a competitive price, like \$4 per gallon, it would be a good alternative energy for oil.

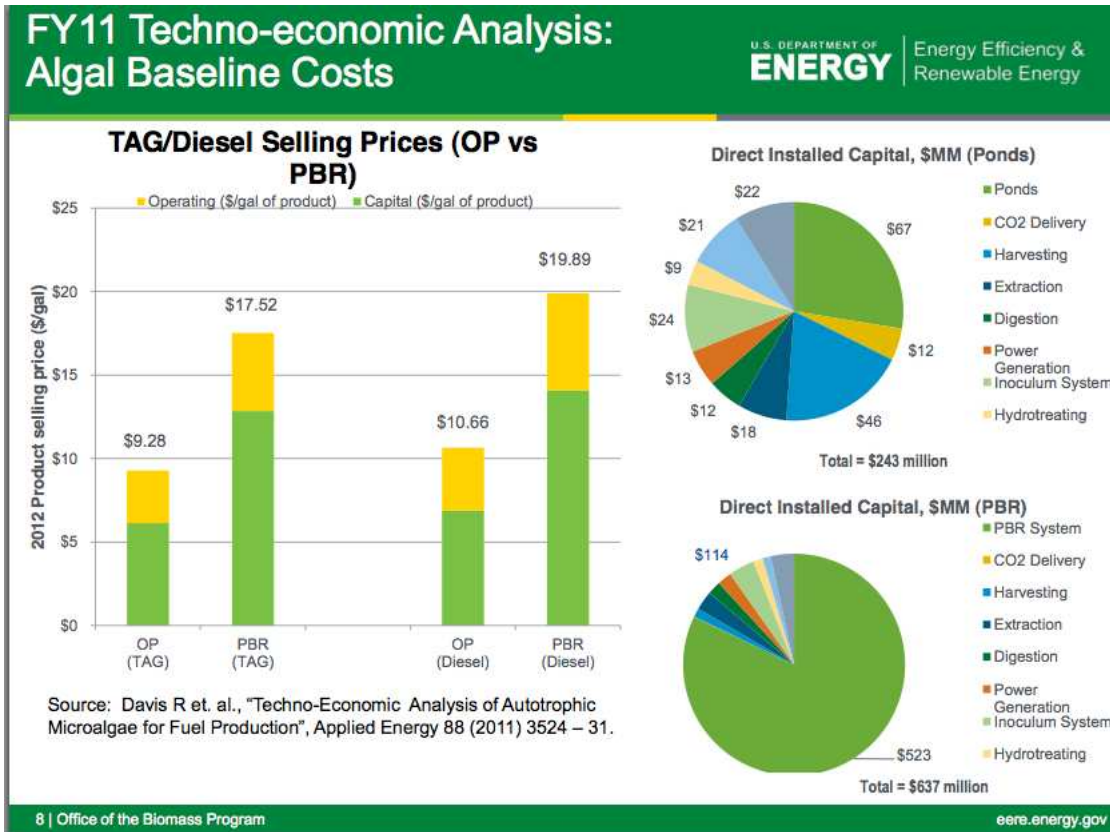

Figure 2.20: Algae Fuel Cost[89]

2.4 Hydropower & Wavepower

Wave power is the energy contained by ocean surface waves, which can be captured and transferred to useful work. Waves are generated by wind passing over the surface of the sea. As long as the waves propagate slower than the wind speed just above the waves, there is an energy transfer from the wind to the waves. Therefore, wave power is renewable and low-carbon. Function to calculate the wave power of a wave:

$$P = \frac{\rho * g^2}{64\pi} * H_m^2 * T \approx (0.5 \frac{kW}{m^3s}) * H_m^2 * T [28]$$

H_m is the significant wave height, T is the wave period, ρ is the water density, g is the acceleration by gravity, and P is the energy flux. Annual generation is around 8000-80000 TWh[63].

There is a potential impact on ocean environment. For instance, noise pollution is a serious problem and is going to have some negative effects on ocean ecosystem. Furthermore, it will take a lot of time and money to build a wave power project in the ocean and it is hard to operate the plant (employees have to keep staying on the sea).

Wave farms:

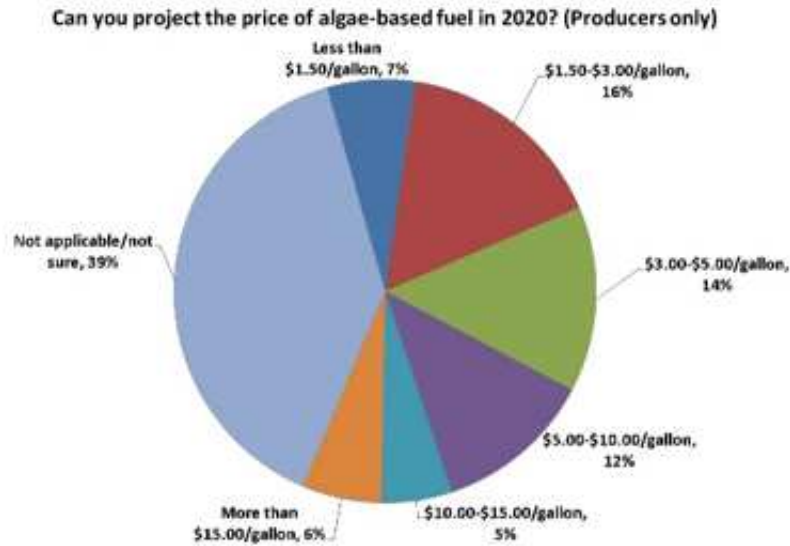

Figure 2.21: Prediction of the price of algae fuel in 2020 (All producers are come from industry related to algae-based fuel.)[93]

1. Portugal: The Aguadoura Wave Farm was the world's first wave farm, with 2.25 MW in total installed capacity. It was located 5 km offshore near Pvoa de Varzim and was officially opened on September 23, 2008.[98]
2. United Kingdom: It is located in Scotland. Was announced on February 20, 2007, which is a 3 MW wave farm.[69]
3. Australia: Ocean Power Technologies (OPT Australasia Pty Ltd) is developing a wave farm connected to the grid near Portland, Victoria.[92]
4. United States: There is a commercial wave park on the west coast of the United States located 2.5 miles offshore near Reedsport, Oregon. And the capacity is 1.5 megawatts.[48]

Tidal power and current power are generated in the same way the water flow drives the turbines and converts the kinetic energy of water flow into useful energy (electricity, work, etc.). Marine currents are caused mainly by the rise and fall of the tides resulting from the gravitational interactions between earth, moon, and sun, causing the whole sea to ow.

Advantages:

1. Compared with solar energy and wind energy, current is more predictable. Therefore, current energy is more stable and can make a continuous supply.
2. Current energy is renewable and has a large capacity.

As the current plays an important role in the ecosystem of ocean, using current power might destroy the environmental balance. The annual generation is around 50,000 TWh[63]

The first study of large scale tidal power plants was by the US Federal Power Commission in 1924 which if built would have been located in the northern border area of the US state of Maine and the south eastern border area of the Canadian province of New Brunswick, with various dams, powerhouses and ship locks enclosing the Bay of Fundy and Passamaquoddy Bay (note: see map in reference). Nothing came of the study and it is unknown whether Canada had been approached the study by the US Federal Power Commission.

In order to utilize these various renewable energy sources better, various technologies are developed to meet the requirement. For example, cars are developed into different types, rather than traditional ones with combustion engines. Now there are cars powered by pure electricity, or powered by hybrid power. Other methods also be tried such as tax break as an incentive program to encourage people to use more renewable energy rather than traditional fuels.

Chapter 3

Energy Policy

3.1 United States

The United States and the world face a daunting array of energy-related challenges. It is important to work out how to provide, reliably and affordably, the supplies of fuel and electricity needed to sustain and build economic prosperity. We must limit the financial drain, vulnerability to supply-price shocks, and risk of armed conflict that result from overdependence on foreign oil. We must reduce the environmental damage done by technologies of energy supply, ranging from local and regional air pollution to the disruption of global climate. We must minimize the accident and proliferation dangers associated with nuclear energy.

In general, for most of the past 15 years, energy matters have seemed to most Americans to be going rather well. Real energy prices were falling. Gasoline lines and electricity blackouts were absent. Urban air quality was generally improving. The science of the impact of fossil fuel use on global climate was widely seen as contentious and inconclusive. There were no major nuclear-reactor accidents after Chernobyl (1986), and concerns about nuclear proliferation and the nuclear energy's role in it were on the back burner.

However, energy policy is still a matter of public concern, what should the policy makers do about it?

First it is necessary to drill the way out of dependency. Overdependence on imported oil is a very real problem. U.S. oil imports are running over 10 million barrels per day, out of total domestic consumption of about 18 million barrels. A quarter of U.S. imports come from the Persian Gulf, and another quarter from other Organization of Petroleum Exporting Countries (OPEC) members. The bill for oil imports in 2000 was well over \$100 billion, passing one percent of GNP for the first time since 1985. The economic impact of oil-import dependence is still not as great today as it was 20 years ago, because oil's share of the nation's energy mix has fallen since then, and because the amount of energy needed to make a dollar of gross domestic product (GDP) has also fallen. But the impact is considerable in sectors of the economy that remain heavily dependent on oil, and oil dependence as a fraction of national energy supply is high enough to make the defense of foreign oil supplies a major mission of U.S. armed forces and, indeed, a potential source of actual armed conflict.

Dependence on imported oil can be reduced by increasing domestic oil production or by reducing oil use; the latter can be achieved either by increasing the efficiency with which oil is converted into goods and services or by substituting other energy sources for oil. All of these approaches have been used in varying degrees over the past two decades, and all of them have a role to play in the decades ahead. All of them can and should be strengthened with further policy initiatives. But analysis of recent history and future prospects indicates that much larger gains will come from reducing consumption through efficiency increases and substitution than from increasing domestic production.

Another issue is the efficiency of energy. The historical record reveals the potential of the energy "resource" that is available in efficiency improvements. For most of the past 30 years, oil's share of U.S. energy supply slowly declined as well, falling from 43.5 percent in 1970 to 38.8 percent in 2000. As for the future, it remains clear that by far the greatest immediate as well as longer-term leverage for reducing dependence on imported oil lies in increasing the efficiency of energy use overall and of oil use in particular. Notwithstanding the impressive efficiency gains over the past 30 years, every serious study of the matter indicates that the technical potential for further improvements remains large.

The expanding of non-oil energy supplies is also a main issue. Although the largest and most cost-effective leverage in the decades immediately ahead resides in increasing energy efficiency, there is also considerable potential in expanding energy supplies from sources other than oil. The sources with the largest short-term and medium-term potential to directly displace oil in the U.S. energy mix are natural gas and biofuels. Natural gas could displace oil in a number of industrial applications, in home heating, and in motor vehicles.

In the transportation sector, which is by far the largest user of oil, the EIA projects contributions from natural gas as a motor vehicle fuel equivalent in 2020 to equal 600,000 barrels per day, about twice the 2000 value? Here too, the potential for natural gas is clearly larger than envisioned by EIA. From an environmental, and quite possibly economic, standpoint, the most attractive candidates to displace some of the growth of gas-fired generation envisioned in the EIA scenario are the non-hydro renewable sources. A very conservative estimate of their potential for doing so out to 2020 is provided by the EIA "high renewables" scenario, which in 2020 obtains 107 billion kilowatt-hours (kWh) from biomass: about 65 billion kWh each from wind and geothermal and 5 billion kWh from solar. The additional non-hydro renewable energy generation in this scenario, compared to the 2000 figure, totals 145 billion kWh, which is equivalent to about 700,000 barrels per day of oil.

3.2 Europe Union

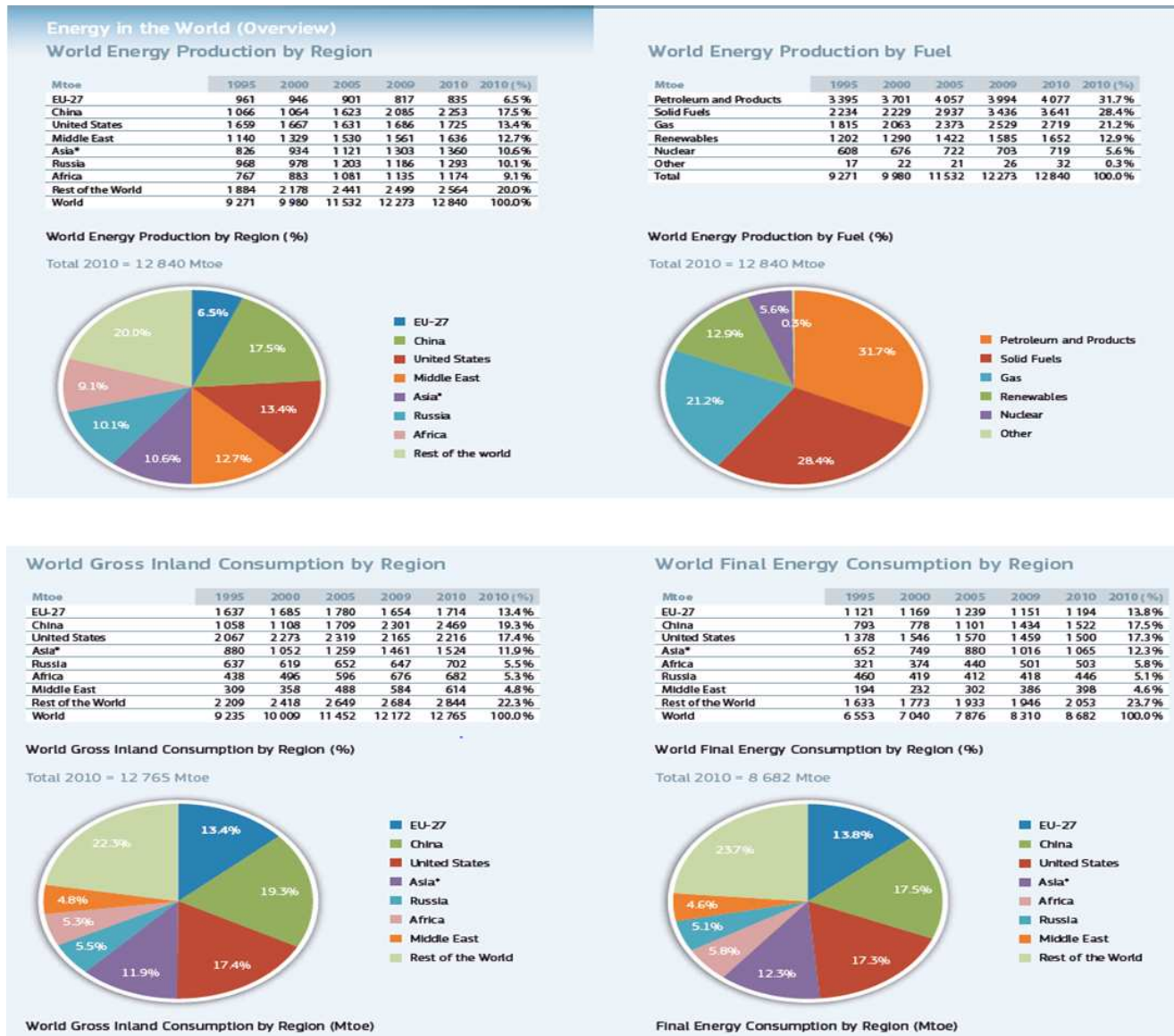

Figure 3.1: Energy in the world(overview)[77]

The figure above shows the world energy of production and the world energy of consumption over the past 15 years. We can see that in 2011 European Union has produced 6.5% of the world's total energy, consumed 13.4% of the world gross inland consumption, which is the total energy demand of a country or region and it represents the quantity of energy necessary to satisfy inland consumption of the geographical entity under consideration, and 13.8% of the world final consumption, which are energy used for the direct satisfaction of individual needs.[120]

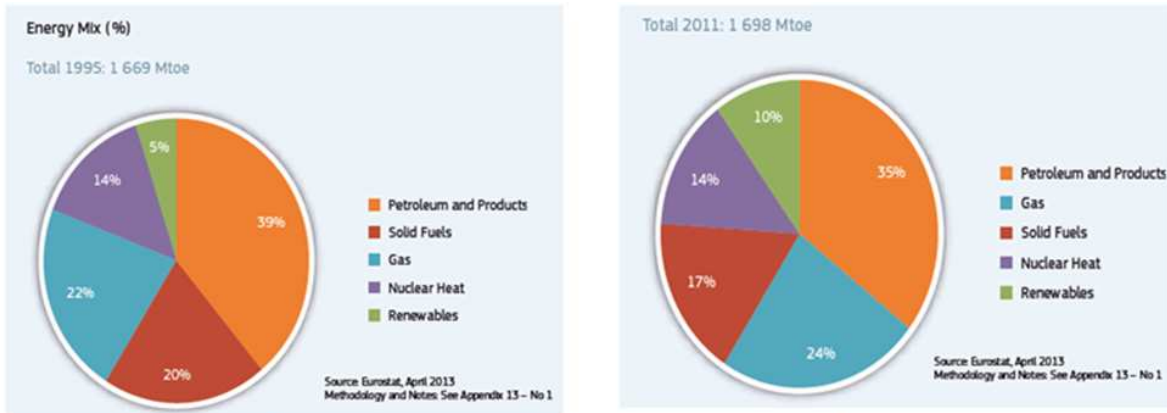

Figure 3.2: Energy consumption of European Union[77]

The two graphs above shows the gross inland energy consumption of European Union. In 1995 there are 1669 Mtoe of energy are consumed, and in 2011, there are 1698 Mtoe of energy are consumed. Mtoe is a unit of energy which is million tons of oil equivalents, the amount of energy released by burning one tonne of crude oil, approximately 42 GJ. We can see that the using of fossil fuel has been decreased; the using of petroleum and solid fuels decreased by 9%, and the use of renewable energy has been increased by 5%.

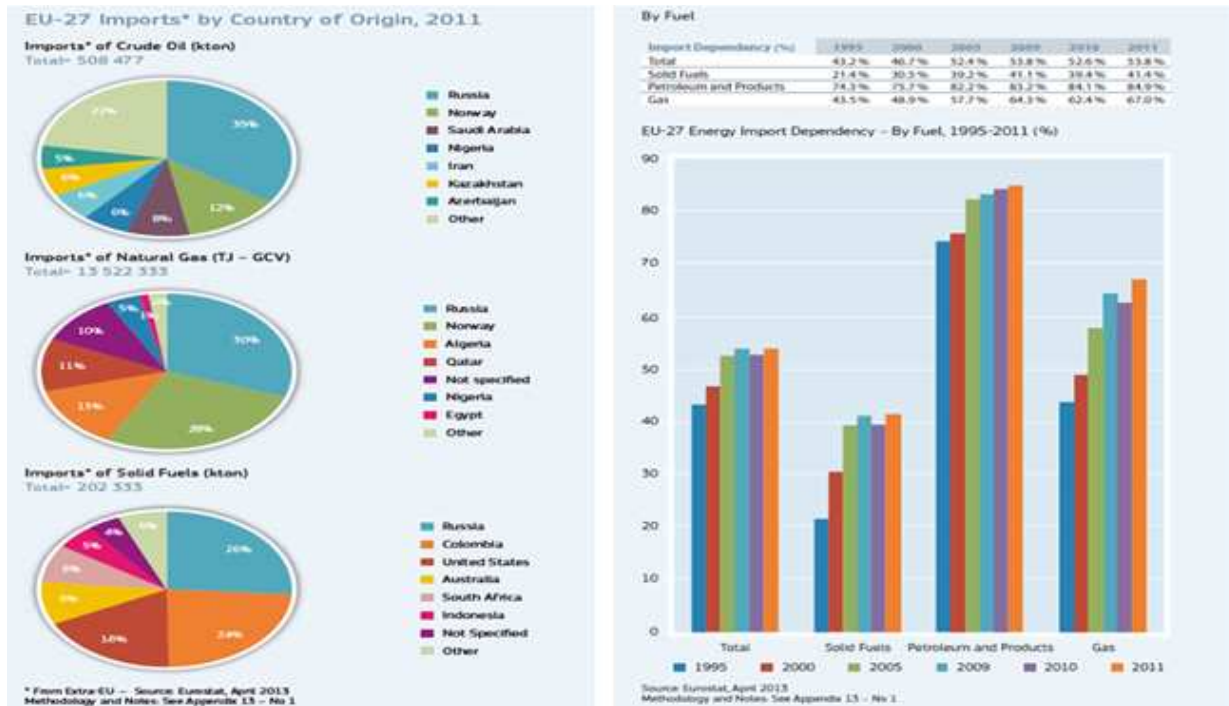

Figure 3.3: Energy import of European Union by country and by fuel[77]

The left part of the figure above shows the energy import dependency of EU. In 1995 about 43.2% of total energy was import, but by 2011, 53.8% of total energy was import. Russia is the largest energy import source for EU. Right part shows that in 2011 35% of imports crude oil, 30% of import natural gas and 26% of import solid fuels are imported from Russia.

A European Energy Policy will firmly commit the European Union (EU) to a low consumption economy based on more secure, more competitive and more sustainable energy. Priority energy objectives involve ensuring the smooth functioning of the internal market in energy, security of strategic supply, concrete reductions in greenhouse gas emissions caused by the production or consumption of energy and the EU's ability to speak with a single voice on the international stage.

The possible principles of Energy Policy for Europe were elaborated at the Commission's green paper A European Strategy for Sustainable, Competitive and Secure Energy on 8 March 2006. As a result of the decision to develop a common energy policy, the first proposals, Energy for a Changing World were published by the European Commission, following a consultation process, on 10 January 2007.[77]

It is claimed that they will lead to a 'post-industrial revolution', or a low-carbon economy, in the European Union, as well as increased competition in the energy markets, improved security of supply, and improved employment prospects. The Commission's proposals have been approved at a meeting of the European Council on 8 and 9 March 2007.[77]

This Communication sets out the European Commission's energy strategy in the period

to 2020. The strategy is structured around 5 priorities:[76]

- Limiting energy use in Europe.
- Building a pan-European integrated energy market.
- Empowering consumers and achieving the highest level of safety and security.
- Extending Europe's leadership in the development of energy technology and innovation.
- Strengthening the external dimension of the EU energy market.

Key proposals include:[77]

- A cut of at least 20% in greenhouse gas emissions from all primary energy sources by 2020 (compared to 1990 levels), while pushing for an international agreement to succeed the Kyoto Protocol aimed at achieving a 30% cut by all developed nations by 2020.
- A cut of up to 95% in carbon emissions from primary energy sources by 2050, compared to 1990 levels.
- A minimum target of 10% for the use of biofuels by 2020.
- That the energy supply and generation activities of energy companies should be 'un-bundled' from their distribution networks to further increase market competition.
- Improving energy relations with the EU's neighbors, including Russia.
- The development of a European Strategic Energy Technology Plan to develop technologies in areas including renewable energy, energy conservation, low-energy buildings, fourth generation nuclear reactor, clean coal and carbon capture.
- Developing an Africa-Europe Energy partnership, to help Africa 'leap-frog' to low-carbon technologies and to help develop the continent as a sustainable energy supplier.

3.3 Japan

Japan lacks significant domestic reserves of fossil fuels, except coal, and must import substantial amounts of crude oil, natural gas, and other energy resources, including uranium, thus most of the resources depending on import from other countries. In 2010, Japan is the first coal importer with 187 Mt (about 20% of total world coal import), and the first natural gas importer with 99 bcm (12.1% of world total gas import). Japan has to rely on oil imports to meet about 42% of its energy needs. Previously with 53 active nuclear power generating reactor units in 2009, nuclear power can help japan to meet about of its electricity need. However, nuclear power is highly influenced by earthquakes. After the 2011 Fukushima Daiichi nuclear disaster, all nuclear reactors have been progressively shut down for safety concerns. As of

January 2013, most cities hosing nuclear plants are okay with restarts.

Compared with other nations, electricity in Japan is relatively expensive and since the loss of nuclear power after the earthquake and tsunami disaster at Fukushima, the cost of electricity has risen significantly. Japan doesn't have a single national grid but instead has separate eastern and western grids. The standard voltage at power outlets is 100V, but the grids operate at 50Hz in Eastern and 60Hz in Western Japan. Two grids were developed by separate companies. Tokyo electric light Co. bought generation equipment from AEG of Germany using the European standard of 50Hz, while Osaka Electric Lamp using GE being the supplier and used the US standard 60Hz.

The two grids operate on different frequencies, making it almost impossible to share electricity if one half suffers a supply problem. There are a lot of discussions about unifying the country on a single frequency, but its always been dismissed as too costly and difficult. The issue came into the public eye again in March, when the Tohoku disaster knocked out roughly a third of the east's capacity, and the excess power in the west couldn't simply be sent over to the east, if the country had a common frequency. The reason is that simply deciding which frequency to adopt would be a political nightmare, touching on the longstanding commercial and cultural rivalry between Tokyo and Osaka. Therefore the solution right now is to share power between the grids by adding conversion capacity. Currently they have three frequency converter stations, and also there is ongoing study on how to expand the country's frequency conversion capacity.

The disaster at Fukushima shows that nuclear power is extremely difficult to handle and inherently dangerous, especially for country having earthquakes frequently. The government should work out a policy as soon as possible that shows a timeline for ending Japans reliance on nuclear power generation. The experience of last summer shows that most power companies in Japan can meet electricity demands even in extremely how weather without relying on nuclear power. Generally speaking, Japans power companies had a fairly safe margin of surplus power. Thus it is deplorable that the Abe (the president of Japan) administration is trying to revive an energy policy that relies on nuclear and coal-burning power generation. The administration is closing its eyes to the tremendous social and economic risks involved in nuclear power, ranging from accidents to the long-term storage of highly radioactive waste.

To protect Japan from the dangers of nuclear power, the government should end its present policy of building large-scale nuclear and thermal power generation plants in a limited number of places. Instead it should pursue a policy of building many small-scale power generation facilities that utilize renewable energy sources near towns and cities across the country. It also should shift from an emphasis on increasing power-generation capacity to an emphasis on reducing demand for electricity.

However, the Abe administration has done next to nothing to reduce Japans power usage and it has virtually no policies to decrease emissions of greenhouse gasses that are widely believed to be responsible for global warming. As long as Japan continues to pursue a policy of operating large-scale thermal power generation plants without increasing the weight of re-

newable energy sources, Japan's greenhouse gas emissions will likely grow.

It is also important to change the current system in which major power companies exercise regional monopolies by both generating and distributing electricity. The function of transmitting and distributing electricity should be removed from the control of major power companies. Such a step would not only encourage new power generating entities to enter the market thus leading to increased competition and lower electricity rates but also enable electricity produced by green power-generating entities to be transmitted to consumers in other regions. The government and major power companies also should build more facilities to convert 50 Hz electricity in Eastern Japan to 60 Hz electricity in Western Japan and vice versa so that electricity can be easily transmitted between the two regions as necessary.

The Democratic Party of Japan government formed its energy policy calling for ending Japan's nuclear power generation in the 2030s after listening to the opinions of citizens and judging that a majority of citizens supported such a policy. But the Abe administration has turned a deaf ear to public opinion and stubbornly pursues its pro-nuclear energy policy.

People should realize that the Abe administration is basing its energy policy primarily upon the opinions of major companies and closely associated experts, with officials of the trade and industry ministry's Agency for Natural Resources and Energy serving as members of the secretariat for their discussion body. This is a revival of the old way of deciding on energy policy that was used by Liberal Democratic Party governments in the past. The majority of citizens who favor an eventual end to Japan's reliance on nuclear power should actively protest against this approach to force the government to change its ways. Otherwise the Abe administration will continue to move toward the restart of nuclear power plants and it will be business as usual.

The Abe administration has largely left management of the crisis at Tepco's Fukushima No. 1 nuclear power plant to Tepco and there is no firm prospect that the government and Tepco will be successful in their endeavors to halt the leaks of radioactive water at the plant site. The central government also has left to local governments the task of devising measures to evacuate and protect local residents in the event of a large nuclear accident.

If the Abe administration fails to set a clear timeline for ending Japan's reliance on nuclear power and continues to push for the restarting of reactors, it will be sowing the seeds of future nuclear problems and the results could be tragic.

Since Tokyo Electric has not come to grips with the problem of how to manage accumulations of contaminated water being used to cool the crippled reactors and the spread of that contamination to groundwater that flows through the plant site to the sea, two and a half years after the three meltdowns at Fukushima, the Abe administration was belatedly forced to state that the government will take measures.

Abe is a longstanding advocate of nuclear power, however, the Fukushima aftermath is hamstringing his ability to push his nuclear agenda. Most of the operating reactors will be

shut down for regular safety inspections and restarting them depends on passing inspections based on safety guidelines introduced in July 2013.

Perhaps Japan's surprisingly robust acceleration of renewable energy capacity may hinder the nuclear village's agenda of reactor restarts, but the commander in the control room is pro-nuclear Abe and he is fully committed to revving up the nuclear industry for what he sees. And, his party ran on an explicitly pro-nuclear platform. Tepco's problems in managing contaminated water have bolstered the anti-nuclear movement, and raised fresh questions about the safe operation of nuclear plants in Japan. But Abe's intervention shows a determination to accelerate reactor restarts and he will probably prevail.

Abe has signaled that national energy policy is in flux, and kicked the can down the road for a decade on a nuclear power target; this non-decision favors the nuclear village because it provides time for settling back into familiar policy ruts. This is not to disregard the importance of grassroots developments and sensible local promotion of renewable energy, but rather reflects the nature of power politics and the key of central government backing and resources. At the end of August 2012, the revival of nuclear energy may have seemed an unlikely scenario due to public opinion polls and hundreds of thousands of anti-nuclear demonstrators taking to the streets, but since then the DPJ failed to approve a cabinet endorsement for phasing out nuclear energy, caving into pressure from the nuclear village and Washington. (Kingston 2012c) And now the LDP, a pillar of the LDP, is back in the driver's seat, controlling both houses of the Diet. The prospects of nuclear revanchism look remarkably strong in spite of the fact that the nuclear crisis lingers.

The nuclear village has openly lobbied the government and actively promoted its case in the media while also working the corridors of power and backrooms where energy policy is decided. Here the nuclear village enjoys tremendous advantages that explain why it has prevailed over public opinion concerning national energy policy. Its relatively successful damage control is an object lesson in power politics. To some extent the lessons of Fukushima are not being ignored as the utilities are belatedly enacting safety measures that should already have been in place, and renewable energy capacity is increasing rapidly, but a nuclear-free Japan by 2030 increasingly seems unlikely. Indeed, the constant drum-beat about fuel import induced trade deficits and mounting power company losses, makes it seem as if restarting nuclear reactors is the only reasonable choice. And even if the public remains skeptical about nuclear safety, Team Abe's Environment Ministry has eliminated nuclear risks by deleting mention of them from its 2013 White Paper.

Furthermore, the power network promoting nuclear energy is not planning to go out of business at home or overseas. Indeed, PM Abe has played a prominent role in promoting reactor exports as his government sees significant market opportunities in exporting nuclear power plants precisely because Japan is at the nexus of the global nuclear industrial complex.

While the large demonstrations and signs of a more robust civil society in 2012 undermined stereotypes of Japanese deference to authority and sparked a degree of euphoria about the prospects of phasing out nuclear energy, it is important to bear in mind the huge obstacles.

The key is that the nuclear village retains veto power over national energy policy and citizens will not get to decide the outcome even if an overwhelming majority support phasing out nuclear energy. However, by ignoring many of the lessons of Fukushima, and fast tracking restarts even as the nuclear crisis lingers, the government and utilities continue to downplay risk, leaving Japan vulnerable to another nuclear accident.

Beside this still non-clear nuclear power situation in Japan, several other new technologies are under ongoing research. One is the space-based solar power. On Earth, harvesting solar energy is limited to daylight hours, and is affected by weather conditions and the seasons of the year. But in space, those constraints don't apply, and space-based solar power could provide a continuous supply of clean, renewable energy, regardless of the time of year or any inclement weather on Earth.

In an effort to increase the options for supplying Japan with energy, their space agency, JAXA, is developing a method of harvesting solar energy from geostationary satellites sitting 36,000 km above the Earth, and transmitting it down to the planet's surface in the form of either laser beams or microwaves. The agency aims to launch a successful space-based solar power system by 2030, and is currently conducting ground-based experiments to determine the most effective way to transmit the energy across large distances.

Sending energy across tens of thousands of miles without huge losses and without endangering any life on Earth does present significant challenges would need to be overcome in order to implement a space-based power system. The energy beam would need to travel 36,000 km and hit a receiving stations just 3 km in diameter on the surface of the planet, but Fukumuro, who is in charge of research planning for the Space Solar Power Systems project, believes "Japan currently has the most advanced technology to do this".

3.4 Australia

Coal and natural gas, along with oil-based products, are currently the primary sources of Australian energy usage. Australia is one of the most coal-dependent countries in the world. It is the fourth-largest coal producing country in the world. In 2005[119], Australia mined 301 million tonnes of hard coal and 71 million tonnes of brown coal. Coal is mined in every state of Australia. It provides about 85% of Australia's electricity production and is Australia's largest export commodity. 75% of the coal mined in Australia is exported, mostly to eastern Asia. In 2005, Australia was the largest coal exporter in the world with 231 million tonnes of hard coal.

Due to Australia's reliance on coal and gas for energy, in 2000 the country was the highest emitter of greenhouse gases per capita in the developed world. It is also one of the countries most at risk from climate change according to the Stern Report.

Renewable energy commercialization in Australia is an area of relatively minor activity compared to the fossil fuels industry. Australia's renewable energy are diverse, covering

numerous energy sources and scales of operation, and currently contribute about 8-10% of Australia's total energy supply. Wind and solar power, biomass fuel and hydro are main types of renewable energy. The figure below shows the percentage of electricity generation from each type among the total electricity generation.

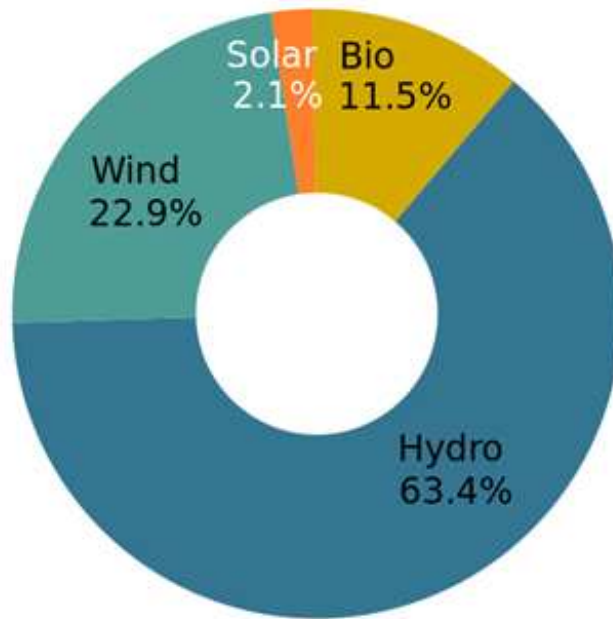

Figure 3.4: Electricity generation from renewable energy in Australia[41]

From the chart above, less than 1% of Australian electricity currently comes from solar power generation. This is mainly due to the higher cost per kW than other power sources because of the cost of solar panels. Innovative applications of photovoltaic technology being developed in Australia include concentrating systems to focus the solar energy on to a smaller area of higher efficiency cells and the use of building integrated photovoltaics, where the PV cells perform architectural or structural functions as well as power generation, thereby off-setting some of the cost. The major area where renewable energy is growing is in electricity generation following the introduction of government Mandatory Renewable Energy Targets. The two most populous states, New South Wales and Victoria have renewable energy targets of 20% and 25% respectively by 2020.[119]

Nuclear power does not have much development in Australia. Jervis Bay Nuclear Power plant was a proposed nuclear power reactor on the south coast of new south Wales. It would have been Australia's first nuclear power plant, but under a serious consideration such as environmental studies and site works, the Australian government decided not to proceed with the project.[119]

First major issue that Australia is facing is to reduce greenhouse gas emissions. However, for the dramatic reduction in the use of coal as carbon capture and storage, this direct action is not expected to be ready before 2020. The energy policy of Australia is subject to the regulatory and fiscal influence of all three levels of Government in Australia, although only the State and Federal levels determine policy for primary industries such as coal. Federal energy policies continue to support the coal mining and natural gas industries through subsidies for fossil fuel use and production as the exports by those industries contribute significantly to the earnings of foreign exchange and government revenues.[119]

3.5 Russia

Russia is always described energy superpower, which means a nation that supplies large amounts of energy resources to a significant number of other states, and therefore has the potential to influence world markets to gain a political or economic advantage.

Russia is not only with quite a lot of energy reserve and production, but also world largest energy exporter. The figure below shows the big difference between consumption and production of Russia's oil. It indicates that most of the energy production in Russia is exported.

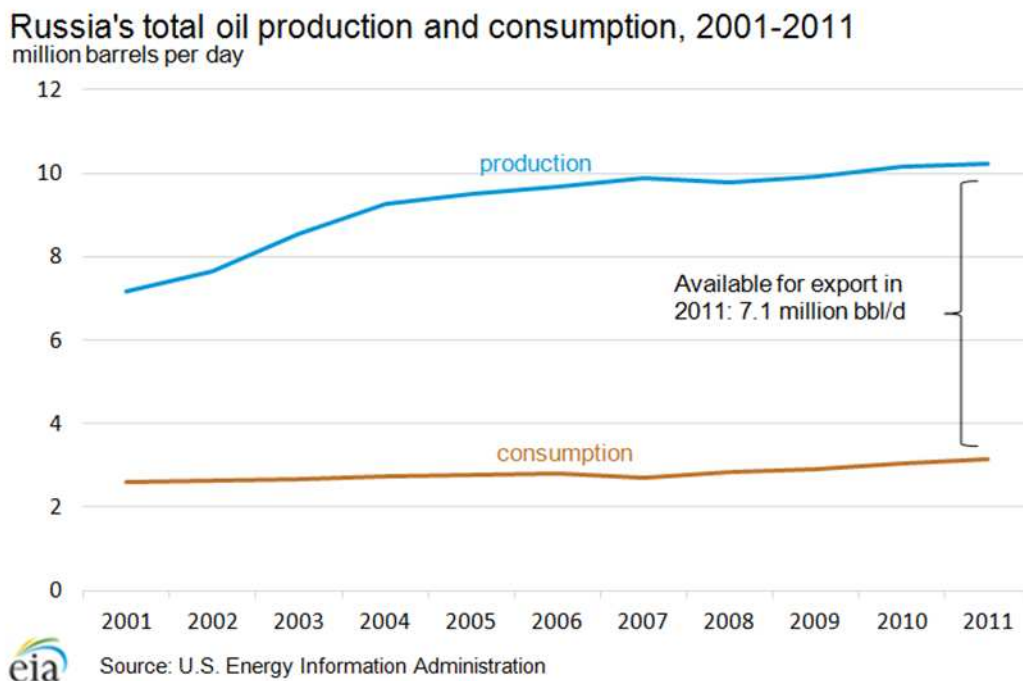

Figure 3.5: Russia's oil production and consumption[15]

Europe is the main destination of Russia energy exportations. As we can see in following figure: Though some of the oil exports to China, United States and Japan, most of them are

exported to Europe.

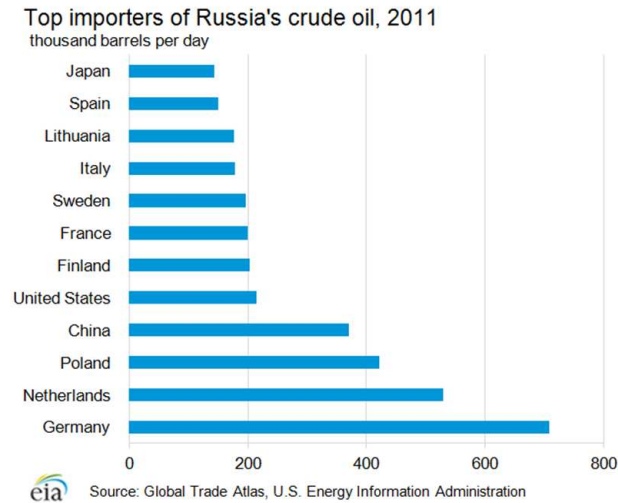

Figure 3.6: Export destinations of Russia crude oil[18]

Same thing happens on natural gas. About 70 percent of Russia's non-CIS exported natural gas is destined for Europe

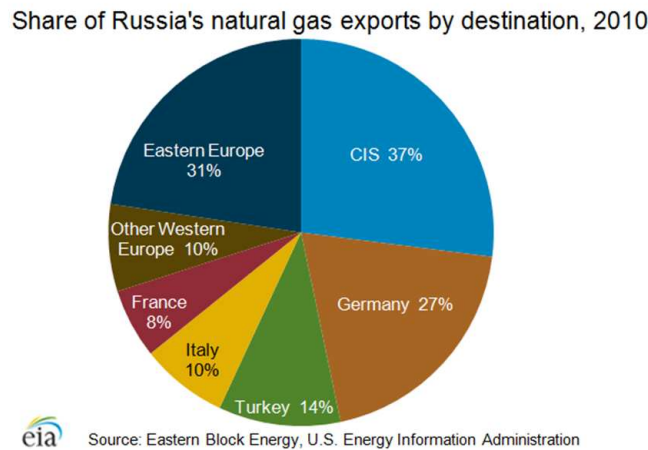

Figure 3.7: Export destinations of Russia natural gas[17]

Thus the energy in Europe is pretty dependent on Russia. And it causes some geopolitics problems.

Since the relationship between Russia and Europe is not stable. Europe countries try to get rid of their energy dependency to Russia. So they plan to construct a new natural gas pipeline from Caspian Sea to Europe which can bypass Russia. It is called Nabucco Gas

Pipeline.



Figure 3.8: Nabucco Gas Pipeline[121]

Now this new pipeline is under construction. But there are many problems such as lacking of investment, uncooperative attitude of Turkey and safety problems in Georgia and Iran. Russia is also constructing a new pipeline called South Stream to complete. And it cannot solve the energy dependency of Europe completely.

3.6 India

India is the fourth largest energy consumer in the world after the United States, China, and Russia. The country depends heavily on imported crude oil and natural gas, mostly from the Middle East.

3.6.1 Challenges

- Gap between energy demand and energy supply is wide and growing.
It is the most serious challenges that India face to. Caused by growing economics and increasing population
- Gap between urban and rural areas as well as among states.
- Implementation of state government.
The central government makes plans and provides funding, but most of the time, it is the state governments that actually execute the plans and implement the projects.

Total energy consumption in India, 2011

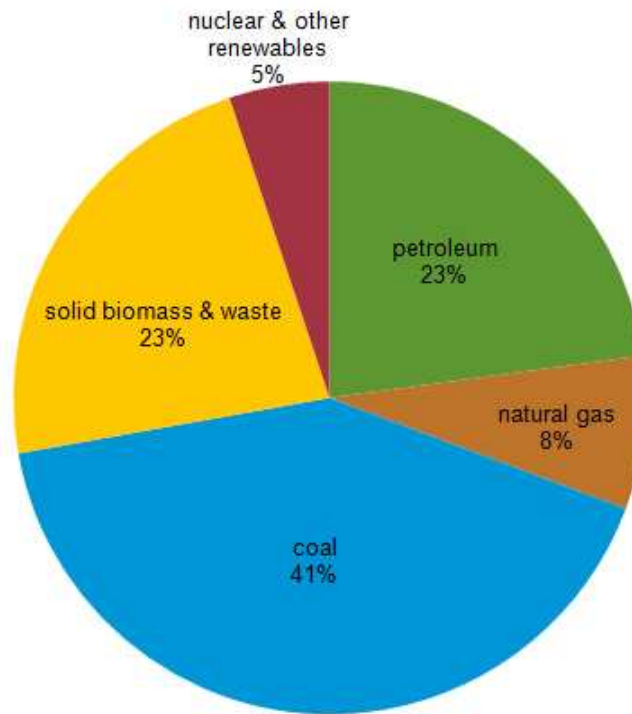

Source: U.S. Energy Information Administration, International Energy Statistics

Figure 3.9: Total energy consumption in India[15]

3.6.2 Policy

- Integrated Energy Policy(IEP), 2008
IEP is the first comprehensive energy policy by the Indian government. Contents include sustainable development; energy security, access and availability; affordability and pricing; efficiency and environmental concerns.
- 12th Five year plans, 2012
More Inclusive and Sustainable Growth; Expand access to energy.
- National Action Plan on Climate Change, 2008
The goal of the plan is to achieve a sustainable development path that simultaneously advances economic and environmental objectives.

3.6.3 Rural Electrification

In India, about 52% of rural households have not yet been electrified even though many of these households are willing to pay for electricity.

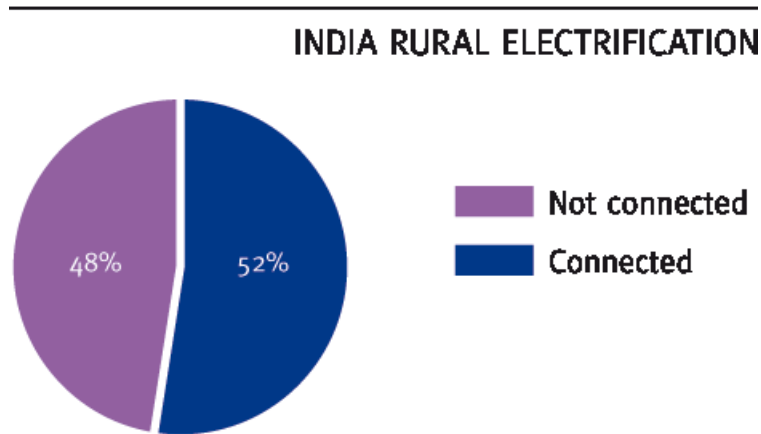

Figure 3.10: India Rural Electrification[91]

India is trying to access electricity to these areas. For the area where the national grid cannot reach, India is using Renewable Sources of Energy like Hydro Energy, Wind Energy, and Solar Energy to build small power plant to electrify villages.

3.7 Brazil

Brazil, officially the Federative Republic of Brazil, is the largest country in both South America and the Latin American region. It is the world's fifth largest country, both by geographical area and by population. In recent 30 years, the energy consumption of Brazil has been growing rapidly since 4.02 quadrillion Btu in 1980 until 11.30 quadrillion Btu in 2010m, as a result of its high-speed improvement of economy.



Figure 3.11: Brazil total primary energy consumption by year[1]

3.7.1 Energy Conservation (Efficiency)[85]

Overview: 109 TWh of electricity savings by 2030

In December 2008 Brazil's president signed the National Climate Change Plan (PNMC). The plan largely focuses on reducing deforestation. The Plan also contains provisions regarding energy efficiency and renewable energy. It seeks to increase energy efficiency across various sectors of the economy in line with best practices, and to maintain the high renewable energy mix in Brazil's transport and electricity sectors.

A national energy efficiency action plan is foreseen to fall within the framework of the PNMC. It will involve a reduction in electricity consumption of around 10 percent by 2030 compared with a reference scenario (equivalent to savings of 106 TWh), which would avoid 30 million tons of CO₂ emissions that same year. The plan also involves the replacement of one million old refrigerators per year for 10 years. Lastly, the plan aims to improve energy efficiency in industry, transport and buildings.

In December 2009, Brazil announced it would decrease its total greenhouse gas emissions by 36.1-38.9 percent by 2020 compared with a business as usual scenario; although the largest part would be achieved through a reduction in deforestation and land use changes, 6.1-7.7 percent of the reduction would come from energy uses.

Figure 1: Total and final energy consumption trends

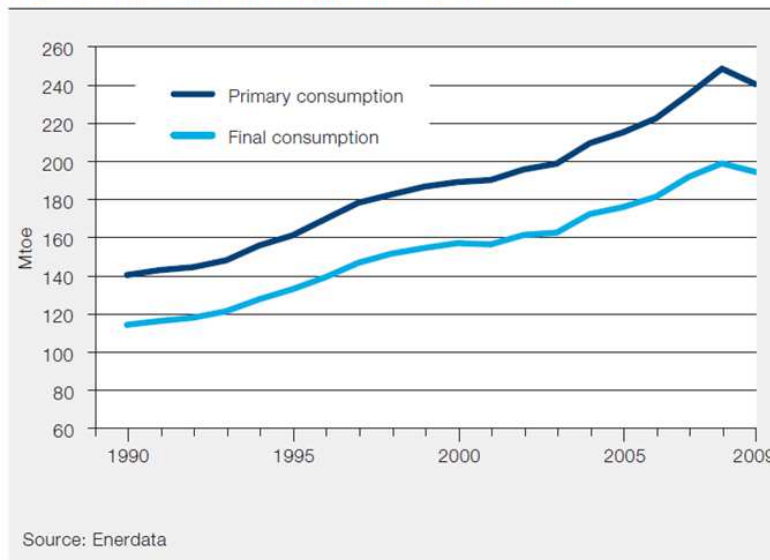

Figure 3.12: Total and final energy consumption trends[1]

Efficiency of the power sector: high efficiency thanks to hydro

Thanks to the large share of hydroelectricity, the efficiency of power generation is high compared with international standards. In 2009 the average efficiency of thermal power generation

was equal to 42 percent, which is 7 points higher than the world average, thanks to the deployment of new gas combined cycle power plants since 2000.

The rate of T&D losses (transmission and distribution losses) in the Brazilian grid is above 16 percent of the distributed volumes, higher than the world average (9 percent). Those losses have increased slightly over time (13 percent in 1990). The PNMC aims to decrease non-technical losses in electricity distribution at a rate of 1,000 GWh per year for the next 10 years.

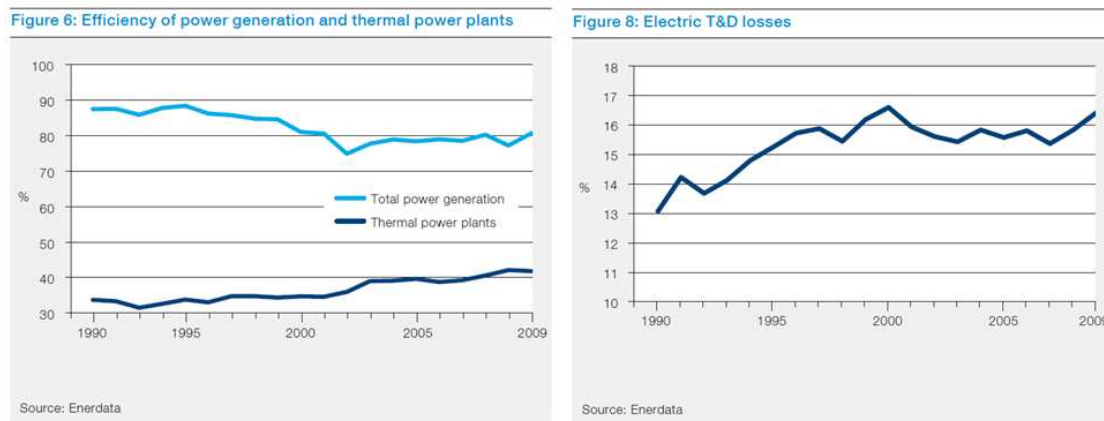

Figure 3.13: Efficiency of power generation and thermal power plants & Electric T&D losses[1]

3.7.2 Renewable energy

Brazil has one of the "cleanest" energy matrices in the world, with about 45% of the overall energy production coming from renewable sources (the worldwide average is about 15%). As mentioned before, the power sector of Brazil is even "greener" with 80% of the country's 120,000 MW installed capacity coming from hydropower.

Bioelectricity (BE): cogeneration from sugarcane bagasse

Brazil's ethanol program started in 1975, when soaring oil prices put a chokehold on the economy. Sugar cane was an obvious candidate, given Brazil's almost endless amount of arable land and favorable climate.

Most cars on the road today in Brazil can run on blends of up to 25% ethanol, and motor vehicle manufacturers already produce vehicles designed to run on much higher ethanol blends. Most car makers in Brazil sell flexible-fuel cars, trucks, and minivans that can use gasoline and ethanol blends ranging from pure gasoline up to 100% ethanol (E100). In 2009, 90% of cars produced that year ran on sugarcane ethanol.

Brazil is the second largest producer of ethanol in the world and is the largest exporter of the fuel. In 2008, Brazil produced 454,000 bbl/d of ethanol, up from 365,000 in 2007. All gasoline in Brazil contains ethanol, with blending levels varying from 20-25%. Over half of all cars in the country are of the flex-fuel variety, meaning that they can run on 100 percent ethanol or an ethanol-gasoline mixture. According to ANP, Brazil also produced about 20,000 bbl/d of biodiesel in 2008, and the agency has enacted a three-percent blending requirement for domestic diesel sales.

Wind power

Wind power in Brazil amounts to an installed capacity of 602 MW at the end of 2009, enough to power a city of about 300 thousand residences. The 36 wind farms in the country in 2009, were located in Northeastern Brazil (5 States), Southern Brazil (3 States), and Southeastern Brazil (1 State). Potential of wind in Brazil is more intense from June to December, coinciding with the months of lower rainfall intensity.

The cost of energy production continues to pose a significant challenge to the growth of wind energy. The price per megawatt hour (MWh) established in Brazil's auction of wind power reserve supply is R\$189 (about 91 \$), while the cap defined in bidding for power plants of the Madeira River Hydroelectricity Complex was R\$ 91 (about 39 \$) in 2008, and R\$ 122 (about 52 \$) in 2007. These hydroelectricity prices were marked down by up to 35% in the 2008 and 2007 auctions; the energy supply was negotiated at R\$ 71.4/MWh. (about 30.6 \$/MWh)

3.8 China

3.8.1 Present status

Energy remains a major strategic issue for China as the country moves towards its goals of modernization and common prosperity for its people.

China is now the world's largest energy producer. Since 1980s China's energy industry has witnessed rapid growth, achieving comprehensive development of coal, electricity, petroleum, natural gas, and new and renewable energy resources. Its universal energy service and civil energy use conditions have markedly improved. Its thriving energy industry provides a guarantee for the country to reduce poverty, improve the people's livelihood and maintain long-term, steady and rapid economic development.

The remarkable enhancement of energy supply capability and security.

In 2011, the output of primary energy equaled 3.18 billion tons of standard coal, ranking first in the world. Of this, raw coal reached 3.52 billion tons; crude oil, 200 million tons; and

refined oil products, 270 million tons. The output of natural gas ballooned to 103.1 billion m³. The installed electricity generating capacity reached 1.06 billion kw, and the annual output of electricity was 4.7 trillion kwh. A comprehensive energy transportation system has developed rapidly. The length of oil pipelines totaled more than 70,000 km, and the natural gas trunk lines exceeded 40,000 km. Electric power grids were linked up throughout the country, and electricity transmission lines of 330 kv or more totaled 179,000 km. The first phase of the national petroleum reserve project was completed, and the country's emergency energy-supply capability keeps improving.

The rapid development in non-fossil energy.

China has made energetic efforts in developing new and renewable energy resources. In 2011, the installed generating capacity of hydropower reached 230 million kw, ranking first in the world. Fifteen nuclear power generating units were put into operation, with a total installed capacity of 12.54 million kw. Another 26 units, still under construction, were designed with a total installed capacity of 29.24 million kw, leading the world. The installed generating capacity of wind power connected with the country's power grids reached 47 million kw, ranking top in the world. Photovoltaic power generation also reported speedy growth, with a total installed capacity of 3 million kw. Solar water heating covered a total area of 200 million m². The state also expedites the use of biogas, geothermal energy, tidal energy and other renewable energy resources. Non-fossil energy accounted for 8 percent of the total primary energy consumption, which means an annual reduction of more than 600 million tons of carbon dioxide (CO₂) emission.

Improvement of science and technology.

A fairly complete system of exploration and development technologies has taken shape in the petroleum and natural gas industry, with prospecting and development techniques in geologically complicated regions and the recovery ratio of oilfields leading the world. Oil drilling rigs that are capable of operating at a maximum water depth of 3,000 m have been built. China is now able to independently design and build oil refinery equipment, each set of which boasts an annual output of 10 million tons, and ethylene production plants, each of which has an annual output of one million tons. Also, 3,000-kw wind power generators have been mass-produced and 6,000 kw wind power generators have come off the production line. The solar photovoltaic industry has formed a sound manufacturing chain, with an annual output of solar panels accounting for more than 40 percent of the world's total.

Challenges

However, as the world's largest energy producer China's energy development still faces many challenges. The country's energy resource endowment is not high and its per-capita share of coal, petroleum and natural gas is low. Its energy consumption has grown too quickly in

recent years, increasing the strain on energy supply.

China's per-capita average of energy resources is low by world standards. China's per-capita shares of coal, petroleum and natural gas account for 67 percent, 5.4 percent, and 7.5 percent of the world's averages, respectively. Although China has experienced rapid growth in energy consumption over the past few years, its per-capita energy consumption is still low - only one third of the average of developed countries.

Grave challenges to energy security. The country's dependence on foreign energy sources has been increasing in recent years. In particular, the percentage of imported petroleum in the total petroleum consumption has risen from 32 percent at the beginning of the 21st century to the present 57 percent. Price fluctuations in the international energy market make it more difficult to guarantee domestic energy supply. It will not be easy for China to maintain their energy securities since its energy reserves are small and its emergency response capability is weak.

Extensive development of fossil energy, particularly coal, has had a serious impact on the eco-environment. Large areas of arable land are taken up for other uses or even spoiled, water resources are seriously polluted, the discharge of carbon dioxide (CO₂), sulfur dioxide (SO₂), nitrogen oxides (NO_x) and toxic heavy metals remains high, and emissions of ozone and particles smaller than 2.5 micrometers (PM_{2.5}) are increasing.

As the largest developing country in the world which contains one fifth of the world's population, China faces the challenge that with the current limited energy resources, how to provide reliable, affordable, clean, renewable and sufficient energy to its people. Therefore Chinese energy development needs to focus on the improvement of energy efficiency, the using of renewable energy, the improvement of high-tech content, less environmental pollution, and secure energy.

Due to the current Chinese environment problem, it is urgent to promoting clean development of fossil energy. Worldwide fossil fuel will keep playing a dominant role in energy supply for a long time; therefore, China will continue to plan fossil exploitation and utilization, with environmental protection taken into account. China needs to keep developing the coal industry in a safe and highly efficient way, spurring clean and highly efficient development of thermal power, actively promoting the development and utilization of non-conventional oil and natural gas resources.

3.8.2 Policy for China

After the research of background information of energy consumption and reserves, renewable energy sources, technologies, and several national policies, we made an energy policy for China based on the situation of China and policies of other countries.

1. Review current funding and historic performance of energy efficiency research and development programs. Based on this review, propose appropriate funding of those research

and development programs that are performance-based and are modeled as public-private partnerships. Rise researches in the fields which need further development.

2. Direct heads of executive departments and agencies to take appropriate actions to conserve energy use at their facilities to the maximum extent consistent with the effective discharge of public responsibilities. Agencies located in regions where electricity shortages are possible should conserve especially during periods of peak demand.
3. Direct the Administrator of the Environmental Protection Agency to work with local and province governments to promote the use of well-designed combined heat and power (CHP) and other clean power generation at brownfields sites, consistent with the local communities interests. EPA will also work to clarify liability issues if they are raised at a particular site.

Chapter 4

Solutions to Energy Problem: Topics on Hydropower

4.1 Hydro Technology

Hydropower is power derived from energy of falling water and running water. It is primarily used to generate electricity and it is one of the most potential renewable energy.

There are five main ways for to generate hydroelectricity:

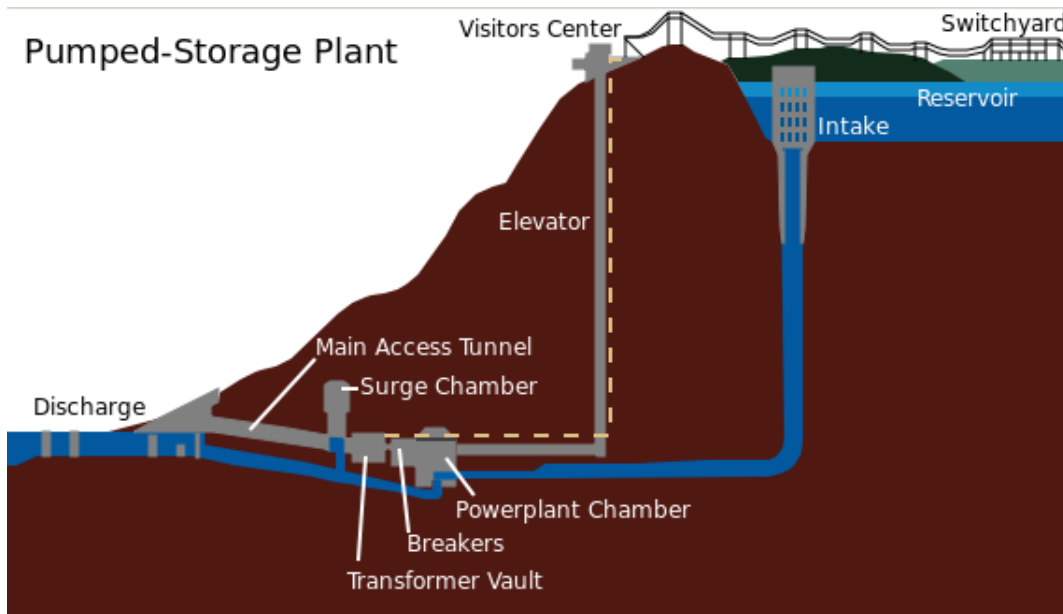

Figure 4.1: An diagram of Pumped-Storage Plant[27]

1. Conventional method: Build dams to store and release water to generate electricity,
2. Pumped-storage method: At times of low electrical demand, store some energy by pumping water to higher elevation. Release the water to generate electricity at times of high electrical demand.

3. Run-of-the-river method: Build dam but has little or no water storage. Economic and environmental friendly.
4. Tide method: Generate electricity through the difference of water level between low tide and high tide.
5. Underground: Use the large natural difference between two waterways, such as a water fall or mountain lake. Generate electricity by constructing a tunnel between them.

A simple formula to evaluate the amount of available hydropower is:

$$P = \eta\rho Qgh$$

Where:

- P = Hydropower(W)
- η = Efficiency
- ρ = Density of water (kg/m^3)
- Q = Flow (m^3/s)
- g = Acceleration of gravity (m/s^2)
- h = The height difference between inlet and outlet (m)

In these variables, ρ and g are nearly constants, Q and h depend on the location. So two main ways to improving the amount of hydro power are looking for choosing good site and improving the efficiency

The most important factor of the efficiency is the Water turbine, a rotary engine that takes energy from moving water.

Affinity laws show the relationship between parameters of water turbine and the power. Below are the laws:

When D is a constant:

$$\frac{Q_1}{Q_2} = \frac{N_1}{N_2} \quad \frac{H_1}{H_2} = \left(\frac{N_1}{N_2}\right)^2 \quad \frac{P_1}{P_2} = \left(\frac{N_1}{N_2}\right)^3$$

When N is a constant:

$$\frac{Q_1}{Q_2} = \left(\frac{D_1}{D_2}\right)^3 \quad \frac{H_1}{H_2} = \left(\frac{D_1}{D_2}\right)^2 \quad \frac{P_1}{P_2} = \left(\frac{N_1}{N_2}\right)^5$$

Where:

- Q = the volumetric flow rate (m^3/s),
- D = the impeller diameter (m),
- N = the shaft rotational speed (rad/s),
- H = the pressure or head developed by the fan/pump (P)
- P = the shaft power (W).

Thus, longer impellers and higher rotational speed would generate more power.

The efficiency in the water turbine include:

1. Hydraulic efficiency: Depends on pumped liquids viscosity and to numerous forms of internal cavitation. Seawater has better hydraulic efficiency on cavitation.
2. Mechanical efficiency: Depends on losses between the drive output shaft and shaft input side.

Modern hydro turbines can convert as much as 90% of the available energy into electricity. The best fossil fuel plants are only about 50% efficient. In the US, hydropower is produced for an average of 0.7 cents per kilowatt-hour (kWh). This is about one-third the cost of using fossil fuel or nuclear and one-sixth the cost of using natural gas.

Hydropower has become the main energy in renewable energy. Especially in the electricity generation, hydropower is definitely the leading source. It provides more than 87% of all electricity generated by renewable sources worldwide. Other sources include solar, geothermal, wind and biomass account for less than 3% of renewable electricity production.” In the US , 81% of the electricity produced by renewable sources comes from hydropower. ”Worldwide, about 20% of all electricity is generated by hydropower.” Some regions depend on it more than others. For example, 75% of the electricity produced in New Zealand and over 99% of the electricity produced in Norway come from hydropower.

4.2 Gulf Stream

4.2.1 Basic Information

Also known as Warm Current of Mexico Gulf, together with its northern extension towards Europe, the North Atlantic Drift, is a powerful, warm, and swift Atlantic Ocean current. Gulf Stream originates at the tip of Florida, and follows the eastern coastlines of the United States and Newfoundland before crossing the Atlantic Ocean. The process of western intensification causes the Gulf Stream to be a northward accelerating current. (Western intensification is the intensification of the western arm of an oceanic current, particularly a large gyre in an ocean basin. Actually, the western intensification is caused by the trade winds blow westward). At about $40^{\circ}0'N$, $30^{\circ}0'W$, it splits in two, with the northern stream crossing to Northern Europe and the southern stream recirculating off West Africa.

Renewable energy, end of 2008 (GW)

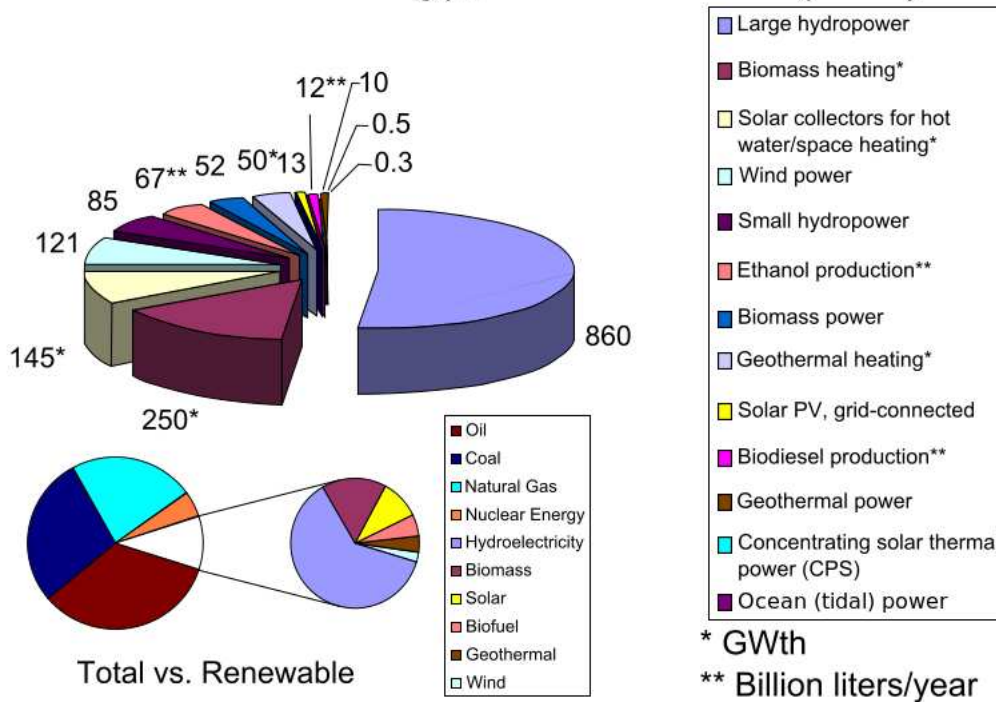

Figure 4.2: Renewable energy[126]

4.2.2 Data

As mentioned before, Gulf Stream is a powerful and large current. The Gulf Stream is typically 100 kilometers wide and 800 meters to 1,200 meters deep. The current velocity is fastest near the surface, with the maximum speed typically about 2.5 meters per second. (And therefore we can calculate the approximate volume flow rate as about 74 million cubic meters to 93 million cubic meters per second). The temperature of Gulf Stream is high to be about 27 degree centigrade when it leaves the gulf, especially in the winter that it can be 8 degree higher than the water around.

Therefore, the recommended position for a project of current energy is the place marked with red line in the map, where the current has a high speed: abundant energy, and a good depth for the installation of the turbines.

4.2.3 Formation (Energy Source of the Gulf Stream)

Actually, using the energy contained in the Gulf Stream is one method to use solar energy, which means that solar energy is the source of the Gulf Stream. The formation of the Gulf Stream is complex, including the factors of trade wind, density difference of sea water between high latitude and low latitude (Main factors), which are both caused by uneven illumination

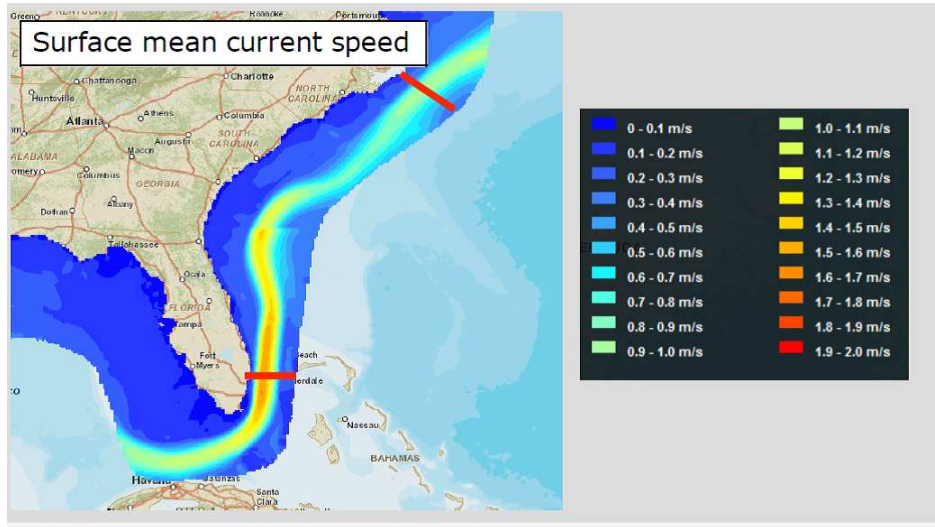

Figure 4.3: Surface mean current speed of Gulf Stream[128]

of sunshine.

Trade Wind[123]

The trade winds blow predominantly from the northeast in the Northern Hemisphere and from the southeast in the Southern Hemisphere, strengthening during the winter and when the Arctic oscillation is in its warm phase.

Density Difference

At low latitude, the salinity content is lower. Therefore, the density of the ocean at low altitude is lower than subtropics, where the density is higher caused by more evaporation water.

4.2.4 Calculation of mean power

To calculate the mean power can be removed without any serious result, we have to first calculate the undisturbed energy dissipation of the Gulf Stream, which means that we need a model for velocity field and mass transported. We can build a model for the Gulf Stream based on Stommel Model (Stommel, 1948). To calculate the approximate max power available for turbine, we still have to do some calibration of the Stommel Model. (As the Gulf Stream has its own energy dissipation cause by friction, we can simulate turbines as additional friction and find in what range that the energy removal is acceptable won't cause a serious problem both on weather and ecosystem).

Stommel Theory: A model of western boundary currents[103]

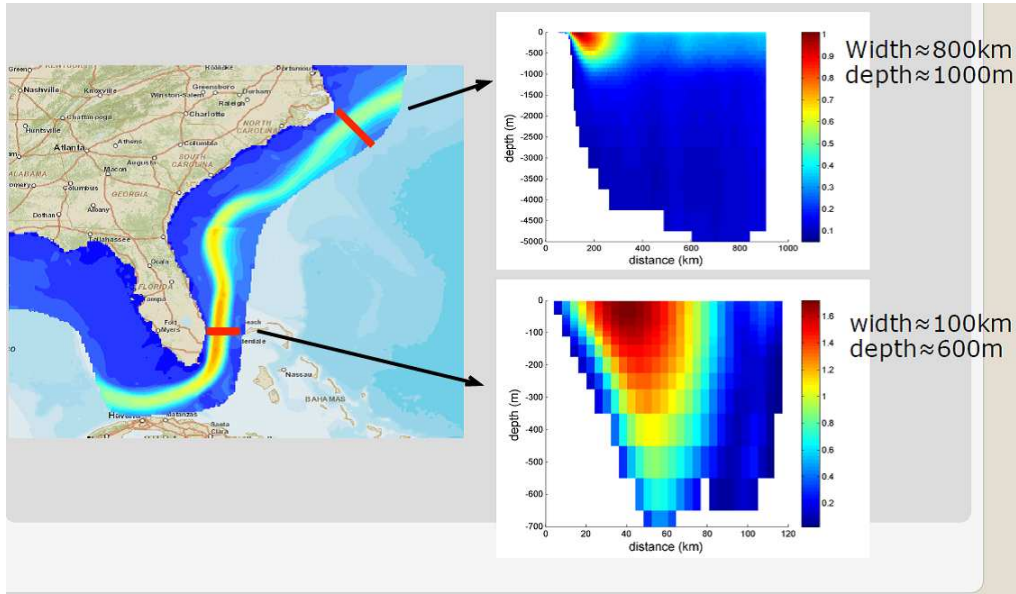

Figure 4.4: Width and depth of Gulf Stream[128]

Actually, to build a model of current, Stommel used the same equations and assumptions as Sverdrup, who developed his own model of ocean circulation.

Sverdrup related the curl of the wind stress to mass transport within the upper ocean. In deriving the relationship, Sverdrup assumed that the flow is stationary, that lateral friction and molecule viscosity are small, and that turbulence near the surface can be described using an eddy viscosity. He also assumed that the flow is baroclinic and that the wind-driven circulation vanishes at some depth of no motion.

$$\frac{\partial p}{\partial x} = f p v + \frac{\partial}{\partial z} \left(A_z \frac{\partial u}{\partial z} \right) \quad \frac{\partial p}{\partial y} = -f p v + \frac{\partial}{\partial z} \left(A_z \frac{\partial u}{\partial z} \right)$$

The equations above are about horizontal components of the momentum

Sverdrup integrated these equations from the surface to a depth $-D$ equal to or greater than the depth at which the horizontal pressure gradient becomes zero. He defined:

$$\begin{aligned} \frac{\partial P}{\partial x} &= \int_{-D}^0 \frac{\partial p}{\partial x} dz & \frac{\partial P}{\partial y} &= \int_{-D}^0 \frac{\partial p}{\partial y} dz \\ M_x &\equiv \int_{-D}^0 p u(z) dz & M_x &\equiv \int_{-D}^0 p u(z) dz \end{aligned}$$

Where M_x , M_y are the mass transports in the wind-driven layer extending down to an assumed depth of no motion.

And he also give us the boundary condition

$$\begin{aligned} \left(A_z \frac{\partial u}{\partial z} \right)_0 &= T_x & \left(A_z \frac{\partial u}{\partial z} \right)_{-D} &= 0 \\ \left(A_z \frac{\partial v}{\partial z} \right)_0 &= T_y & \left(A_z \frac{\partial v}{\partial z} \right)_{-D} &= 0 \end{aligned}$$

Where T_x and T_y are the components of the wind stress.

Stommel used essentially the same equations above but added a simple bottom stress proportional to velocity.

$$\begin{aligned} \left(A_z \frac{\partial u}{\partial z} \right)_0 &= -T_x = -F \cos(xb/y) & \left(A_z \frac{\partial u}{\partial z} \right)_D &= -Rv \\ \left(A_z \frac{\partial v}{\partial z} \right)_0 &= -T_y = 0 & \left(A_z \frac{\partial v}{\partial z} \right)_D &= -Ru \end{aligned}$$

F and R are constants.

Stommel calculated steady-state solutions for flow in a rectangular basin $0 \leq y \leq b, 0 \leq x \leq \lambda$ of constant depth D filled with water of constant density. His first solution was for a non-rotating Earth. This solution had a symmetric flow pattern with no western boundary current. Next, Stommel assumed a constant rotation, which again led to a symmetric solution with no western boundary current. Finally, he assumed that the Coriolis force varies with latitude. This led to a solution with western intensification. Stommel suggested that the crowding of stream lines in the west indicated that the variation of Coriolis force with latitude may explain why the Gulf Stream is found in the ocean.

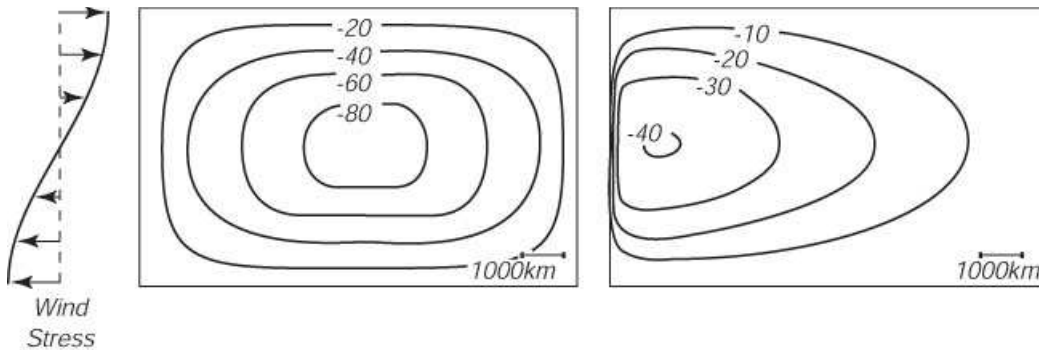

Figure 4.5: Streamline of Gulf Stream based on Stommel Model[128]

This is the result based on Stmmel Model from Ocean Current Energy Assessment for the Gulf Stream.

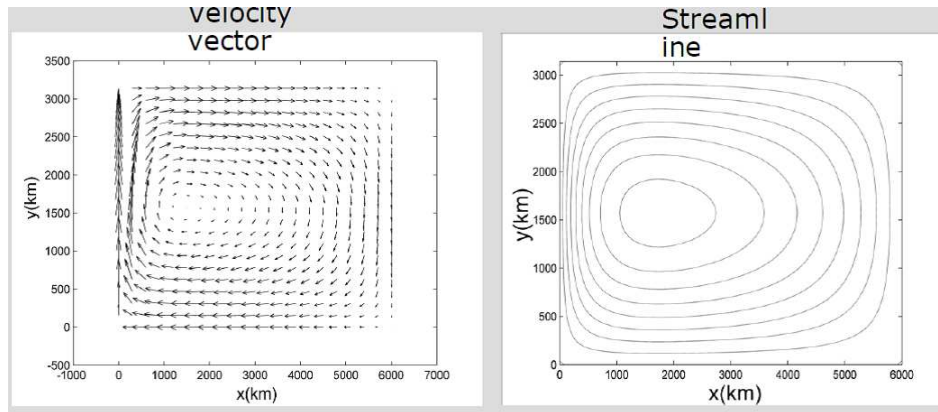

Figure 4.6: Velocity vector and streamline of Gulf Stream[128]

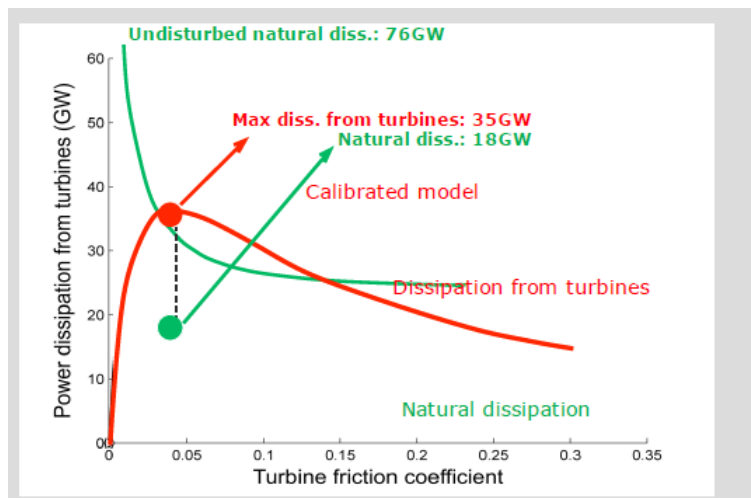

Figure 4.7: Maximum of dissipation from turbine[128]

4.3 Bay of Fundy

The highest tides in the world occur in the Bay of Fundy, which is located between Nova Scotia and New Brunswick.[29] The height of the tide difference ranges from 3.5 meters (11ft) along the southwest shore of Nova Scotia and steadily increases as the flood waters travel up the 280 km (174 miles) of shoreline to the head of the Bay where, in the Minas Basin, the height of the tide can reach an incredible 16 meters (53ft). [97]

The average tidal range of all oceans around the globe is 1 meter (3ft), so how can the tidal difference in the Bay of Fundy reach up to 16 meters? This tidal phenomena exists because the bay has a few distinct features: a substantial amount of water and a unique shape and size that causes resonance.[97]The water in the bay moves back and forth in sync with the oceanic tides outside that there is such a large increase in the tidal range towards the head of the Bay. Also the bays shape and bottom topography also have a secondary influence on the tides. The bay is shaped like a large natural funnel; it becomes narrower and shallower

towards the upper part of the bay, forcing the water higher up onto the shores.



Figure 4.8: Bay of Fundy[97]

The large tidal amplitudes in this region are driven by the near-resonance of the Bay of Fundy, Gulf of Maine system, which has a natural period of approximately 13 hours close to the 12.42 hour period of the forcing tides,[56][57] and during the tidal period, 115 billion tonnes of water flow in and out of the bay. The force created by these mighty waters is equal to 8000 locomotives or 25 million horses at the Minas Channel.

Figure 4.9 above shows Bay of Fundy region over which the tides were numerically simulated. The colors represent the bathymetry (m) of the region, but it should be noted that beyond the continental shelf (the dark red region) the depth is typically in excess of 4000m. The input tides are specified on the open boundary of the domain which is illustrated by the thick gray line, whereas the black line passing through the center of the Bay of Fundy approximates the path of the tidal wave.

To numerically simulate the tides, a finite element grid was used which consisted of the Bay of Fundy, Gulf of Maine and a region of the Atlantic Ocean as illustrated in Figures 4.8 and 4.9. The entire region (Figure 4.8) was approximately $600\,000\text{km}^2$ in area.

Figure 4.10 shows the location of nine observation stations which were used to compare the numerical results to measured data. The figure also displays the finite element grid that was obtained from David Greenberg.

An important characteristic of the finite element grid, which is evident in Figure 4.9, is that regions of complex bathymetry and geometry are characterized by a greater resolution. In particular, the densities of the triangular elements near the coastline and in shallow regions are much greater than that in the deep Atlantic Ocean. To numerically simulate the tides,

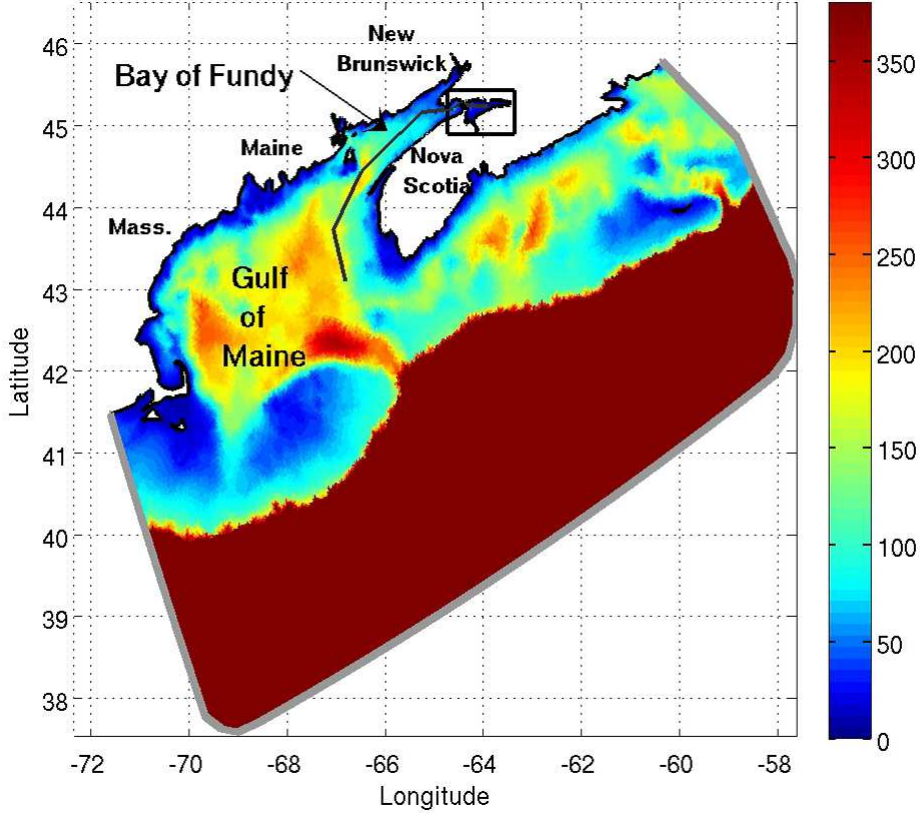

Figure 4.9: Bathymetry(m) of the Region[67]

a Finite-Volume Coastal Ocean Model (FVCOM),[36] an unstructured grid, finite-volume, 3D primitive equation, turbulent closure coastal ocean model, is used. For the purposes of this research, the solutions are governed by the two-dimensional momentum and continuity equations, given by

$$\begin{aligned} \frac{\partial u}{\partial t} + u \frac{\partial u}{\partial x} + v \frac{\partial u}{\partial y} - fv &= -g \frac{\partial \zeta}{\partial x} - F_x \\ \frac{\partial v}{\partial t} + u \frac{\partial v}{\partial x} + v \frac{\partial v}{\partial y} + fv &= -g \frac{\partial \zeta}{\partial y} - F_y \\ \frac{\partial \zeta}{\partial t} + \frac{\partial}{\partial x}[u(h + \zeta)] + \frac{\partial}{\partial y}[v(h + \zeta)] - fv &= 0 \end{aligned}$$

where x and y are the east and north directions; u and v are the depth integrated east and north velocities; f is the Coriolis parameter ($f = 2\pi \sin(\text{latitude})$); g is the gravitational acceleration; h is the undisturbed depth of water; ζ is the height of the free surface relative to h ; t is the time; and, F_x and F_y are the east and north quadratic friction forces given by where k is the bottom friction coefficient.

$$F_x = \kappa u \frac{\sqrt{u^2 + v^2}}{h + \zeta} \quad F_y = \kappa v \frac{\sqrt{u^2 + v^2}}{h + \zeta}$$

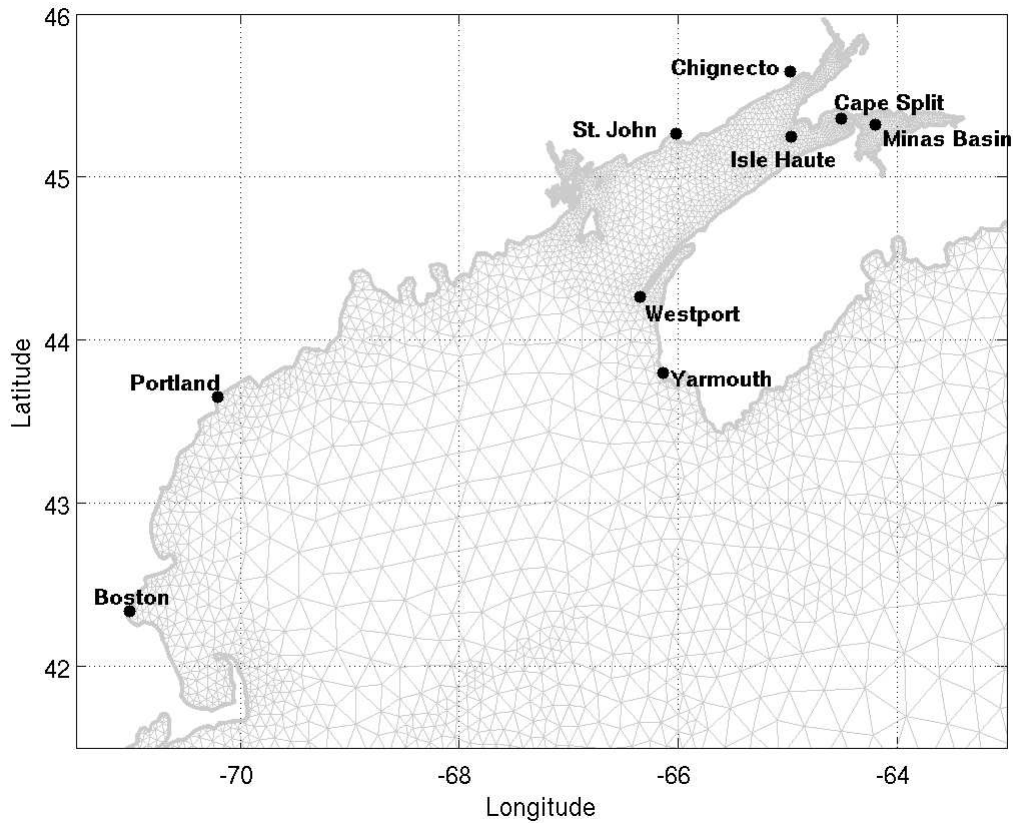

Figure 4.10: The Location of Nine Observation Station[36]

It is important that the open boundary is located beyond the continental shelf, allowing the Bay of Fundy to respond freely to the tidal forcing. Using FVCOM, the tides are then simulated with the values of u , v and ζ saved every $1/24$ of a tidal period for the last four periods of a 16 tidal period run. The amplitude and phase of the tides can then be calculated at each node by fitting a cosine curve to the surface height. To ensure that the simulations were producing accurate results, these values were compared to measured values for the tidal phase and amplitude at 51 observation stations obtained from David Greenberg. The locations of nine of these stations are shown in Figure 4.10.

In order to achieve the most accurate results, the model was tuned by adjusting the bottom friction coefficient until the mean amplitude difference between the calculated and observed values was a minimum. After conducting several numerical simulations, this bottom friction coefficient was determined to be 0.0026.[50]

Figure 4.11 shows the numerically simulated amplitude (m) and phase ($^\circ$) of the M2 tide in the Minas Passage and Minas Basin are represented by the colors and contours, respectively. The over 10° phase difference across the Minas Passage creates the large tidal head driving the flow through the channel.

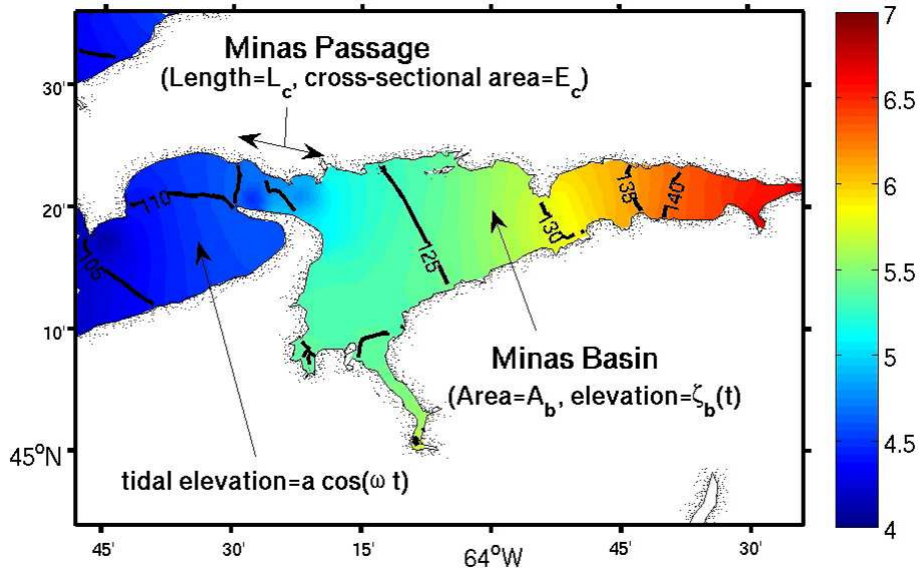

Figure 4.11: Numerically Simulated Amplitude and Phase[80]

The power per unit area can be determined by calculating the time averaged kinetic energy flux which is given by $P_{KE} = \frac{\rho}{2T} \int_0^T (U^2 + V^2)^{3/2} dt$, where T is the length of one tidal period (12.42 hours) and ρ is the density of the water. As illustrated by Figure 4.11, the power density in the Minas Passage exceeds 18 kW/m^2 which is much greater than anywhere else in the region due to the high velocity of the flow passing through this channel. By integrating across the channel, Triton Consultants[80] estimated that the total power associated with the kinetic energy flux is 1.9 GW in the Minas Passage.

Figure 4.12 shows the power density (kW/m^2) in the Minas Passage is much greater in this region than anywhere else in the Bay of Fundy where the power density is typically less than 2 kW/m^2 . The high power density in this region makes it a promising location for the implementation of turbines.

Several proposals to build tidal harnesses for electrical power generation have been put forward in recent decades.[50] The Annapolis Royal Generating Station consists of a dam and 18 MW power house and 50 GWh annual generation on the Annapolis River at Annapolis Royal, which could generate 4600 average US households. But larger proposals have been held back by a number of factors, including environmental concerns, an accelerated shoreline erosion problem, as well as increased siltation and heavy metal and pesticide contamination upstream due to lack of regular river/tidal flushing.

There have been proposals in recent years for installing underwater hydrofoils, which would not require any damming or blockading of parts of the bay but would instead generate power solely by being placed in areas of high water flow, such as at choke points or merely along the

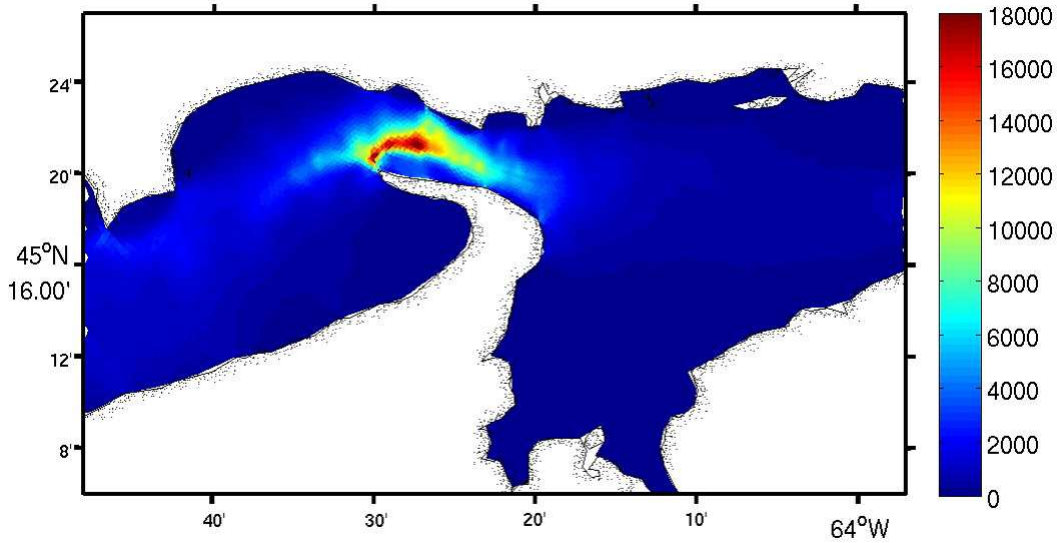

Figure 4.12: Power Density in the Minas Passage (Unit: kW/m^2)[80]

floor of any part of the bay which experiences strong currents.

Power from water comes almost entirely from dams, providing nearly 7% of the country's electricity needs. The US Department of Energy estimates that number will more than double by the year 2030, rising to 15%. And the potential is even greater than that.[110] Converting the motion of waves or tides into electrical energy in the U.S. has the potential to supply thousands of terawatt-hours per year, or roughly one third of the electricity used now.[73]

Ocean Renewable Power Company (ORPC) is a tidal energy company based in Portland, Maine.[95] It completed an eight month pilot project to generate energy using the technology in 2013.[52]



Figure 4.13: An Underwater Turbine in Cobscook Bay[127]

After five years of planning, the company installed an underwater turbine to use the tides to generate clean, renewable energy. The unit is nearly 100 feet long and sixty feet below the water's surface, as shown in figure 4.13.[110] The project, located in Cobscook Bay, on the west side of Eastport, Maine[127] transmitted the first electricity ever delivered to an electricity grid from an ocean resource in North or South America. The only comparable project uses a dam in Nova Scotia. ORPC completed an eight month pilot project to generate energy from its Cobscook Bay project.[52]

It's a \$21 million dollar project and it produces enough electricity for 25 homes. It's just the starting point, Ocean Renewable Power Company is planning to add more turbines in different locations.[73] In the scheme of the broader electrical grid, it about enough to power 1,200 homes and businesses in Maine. The power generated will be purchased from three Maine utilities at a starting price of 21.5 cents per kilowatt-hour, [73] or almost double Maines average electricity prices 11 cents, which is not competitive at all. However as the drill gets more efficient the will be significantly cheaper. Although compare to other fossil fuels generated electricity, price is not a pro for tidal project. However from renewable point of view, if we keep the environmental impact in count tidal energy generated electricity is more suitable for current path of energy development.

4.4 Hydropower and Ocean power in China

Nowadays the most widely used form of renewable energy is hydropower (or named as hydroelectricity power). It accounts for 16% of global electricity generation, and is expected to increase approximately 3.1% every year for the next 25 years[87].

In 2010, the Asia Pacific region generated 32% of the global hydropower, and 22% of that was from China[87]. China has large quantities of rivers, more than 50,000 of which cover a basin area over $100km^2$, and 3886 of which have hydropower potential over $10MW$. The research and investigation on hydro resources have been carried out for around 60 years in China [130]. According to the report of world hydro potential and development[26], the gross theoretical hydropower potential of China (mainland) is estimated as $6083,000GWh/year$. According to the Renewable 2012 Global Status Report, Chinas capacity even exceeds that of Brazil, the USA and Canada combined[87]. At the same time, Chinese government still targets for continued hydropower installation. By 2015, Chinas hydropower installations are targeted to reach around $325 GW$, and by 2020 with a target of $430GW$. Investment in hydropower becomes one of Chinas key areas of focus.

For the regional distribution, Southwest China has the most rich hydropower resources, which includes four provinces: Sichuan, Yunnan, Tibet and Guizhou. Fig.1 shows the percentage of hydropower resources possessed by different regions.

By 2007, the installed capacity and energy generation of hydropower had totaled $145.26GW$ and $486.7TWh$. The annual average growth rates were 12.% and 11.9%[53][40]. The volume doubles in less than 7 years. The share of hydropower in the total installed capacity rose

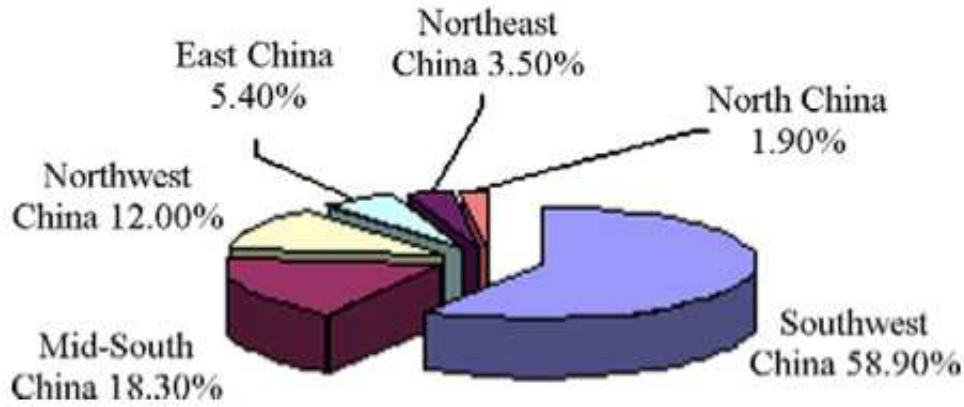

Figure 4.14: The distribution of economically exploitable resources in China[75]

from 8.8% in 1949 to 20.36% in 2007, indicated in Fig. 2. In 2005, the installed capacity and energy generation of hydropower in China both ranked first in the world, and China also shared 13.3% of the world’s hydro production. But the development level is only about 21.5% far below the world average. In addition, hydropower still accounts for a minor share in the total electricity production in China, however, it accounts for 98.9% in Norway and about 83.7% in Brazil respectively.

Year	Installed capacity (GW)	Share (%)	Energy generation (TWh)	Share (%)
1949	0.163	8.8	0.71	16.5
1957	1.019	22.0	4.82	24.9
1965	3.02	20.0	10.41	15.4
1970	6.235	26.2	20.46	17.7
1975	13.428	30.9	47.63	24.3
1980	20.318	30.8	58.21	19.4
1985	26.42	30.4	92.4	29.0
1990	36.05	26.1	126.7	20.4
1995	52.18	24.0	186.8	18.6
2000	79.35	24.9	243.1	17.8
2002	84.56	24.0	271.0	16.5
2003	94.90	24.25	281.3	14.76
2004	108.26	24.57	328	15.00
2005	116.52	22.90	395.2	16.00
2006	128.57	20.67	416.7	14.70
2007	145.26	20.36	486.7	14.95

Figure 4.15: Growth of hydropower in China[53][40][39]

China had 21 large (capacity greater than 1000MW) hydropower plants in operation, with a gross installed capacity of 39.73GW, accounting for around 34.2% of Chinas total. Besides, 182 large and middle-scale hydropower plants are under construction, with a gross installed

capacity of 92.5GW. Most of the built hydropower plants will mainly be used for energy generation, only a few of them needed for flood protection and irrigation.

Most hydropower plants of China are located in the provinces that are lack of coal or have an abundance of hydro resources. Fig. 3 shows 13 hydropower bases that China planned according to the distribution of hydropower resources. If the hydropower resources in these bases are completely developed, the installed capacity will amount to 275.77GW.

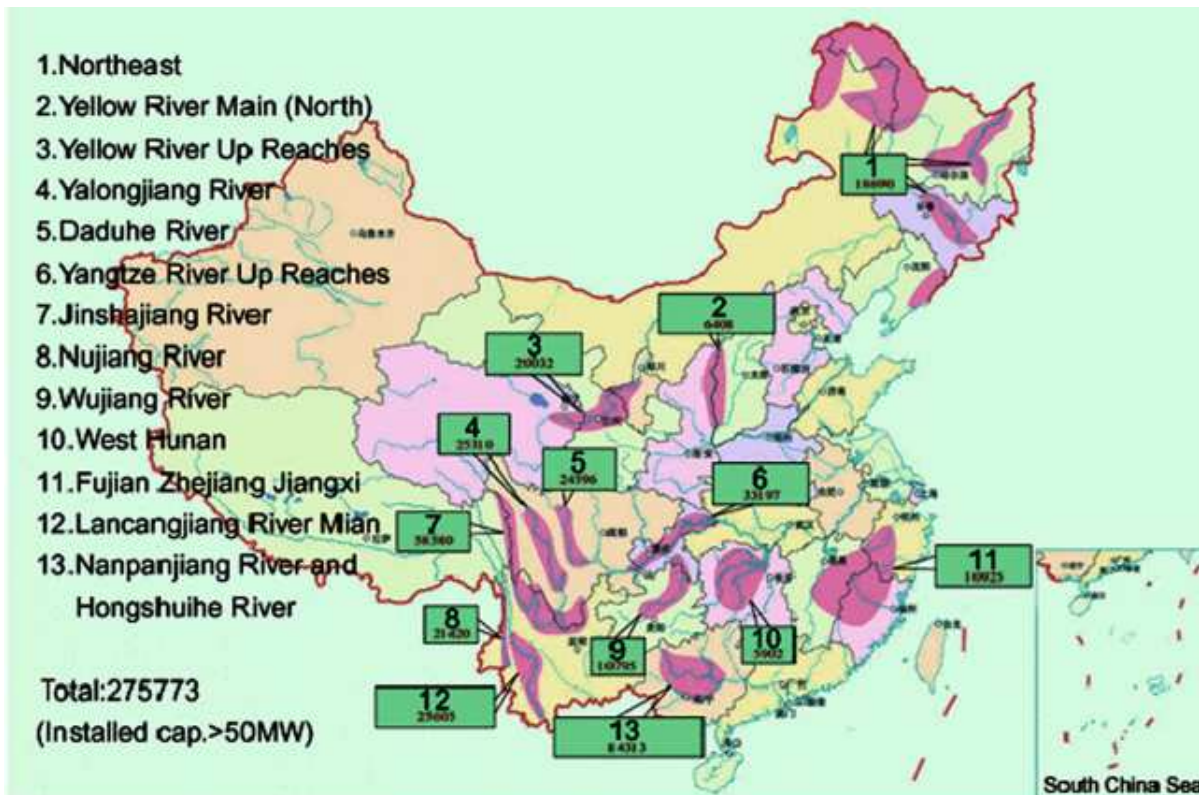

Figure 4.16: Location of 13 Hydropower Bases in China[99]

Based on the consideration of hydropower resources, submergence, construction cost and other factor, China has given the Yellow River Up Reaches, Hongshuihe River, the Yangtze River Up Reaches and Wujiang River priorities to develop.

In China, small hydropower plants (installed capacity of less than 50MW) 's technically exploitable capacity is estimated as 128GW, with an average energy generation of 450 TWh/year. They are widely distributed in more than 1600 mountainous counties around China. With the rural economic growth and governmental support, the small hydropower has developed rapidly, more than 40,000 small hydropower plants had been built [99].

The Three Gorges Dam has a great importance for china. It is the worlds largest hydropower station spanning the Yangtze River in terms of installed capacity with a maximum capacity of 22.5GW. According to the Chinese Society for electrical engineering, the dam

was expected to provide 10% of China's power, however, as electricity demand continued to increase during the lengthy construction period, the dam only supported around 1.7% of electricity demand in China in 2011.

Comparing with other renewable energy forms, such as wind or solar, hydropower can be regarded as the most cost-effectiveness energy source, allowing developers to install hydroelectric power without the need for considerable feed in tariffs. In addition, hydro power plants can be able to adjust their output quickly to adapt to changing energy demands over certain periods. The plants have long economic lives, and operating labor cost is also usually low.

However, Chinese government also faces many hurdles for hydropower development. First, precipitation is important while developing hydropower, but the temporal and spatial distribution of precipitation is badly uneven in China. This not only makes the river flow vary dramatically within one year from the flood season to dry season, but also may lead to continuous dry or wet years. Second, building large scale hydropower plants will cause inevitable submergence of lands and resettlement. For example, while building the Three Gorges Dam, almost 1.5 million people were displaced due to the construction of the dam. A level of displacement will make future hydropower development more complicated. In addition, it will bring some negative influence on the ecosystem. The enormous reservoir created in the Yangtze River by the Three Gorges Dam project is now plagued by pollution and in 2009, construction on a major hydropower dam project was halted due to environmental objections. In 2012, China is still experiencing one of the most severe droughts in the past 50 years, affecting water availability and flows, complicating the coordination and integration of hydro power. Since China is a country with a huge population, and fragile ecosystem, all these will increase the difficulty for hydropower development.

In light of current trends, ocean energy will be one of the important energy sectors in coastal countries. Usually the ocean energy refers to the energy inherently derived from the ocean, such as tidal energy, wave energy, thermal energy, salinity energy, current energy, etc.

China has a long coastline and wide sea areas, which contains abundant ocean resources. 90% of these resources are distributed along the coastal of the conventional energy shorted east china regions such as Shanghai, Zhejiang and Fujian. More than 80% of China's tidal energy resources are distributed in Fujian and Zhejiang and ocean thermal energy is mainly in South China Sea. Current energy and salinity energy are rich in sea areas to the south of Yantze River Estuary[129][115][90][116][78]. Currently in China, wave energy and thermal energy are the richest, current energy and tidal energy are less[70]. The government of China is committed to developing ocean renewable energy.

4.4.1 Tidal Energy

Tidal energy is the potential energy of water caused by flood and ebb tide, and it can be extracted by building a dam across an estuary or coastal inlet, the dam containing turbines to generate electricity. The tidal energy is about proportional to the square of the tidal range

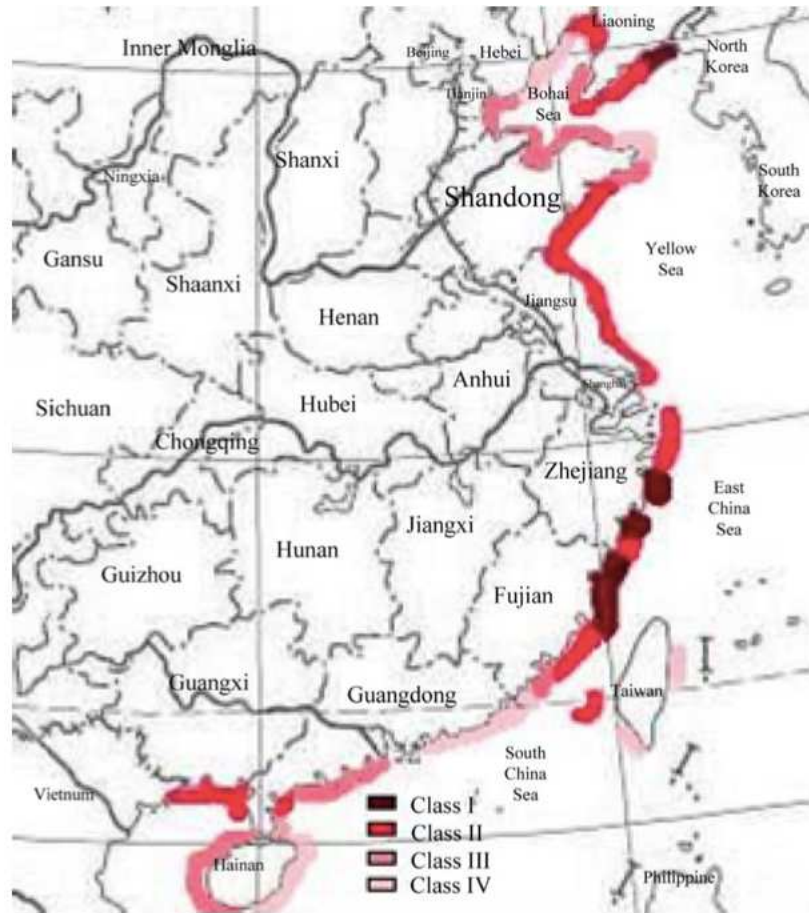

Figure 4.17: Tidal Energy Resources Distribution in China[90]

and area of the water trapped in the barrage. In China, the estimated theoretical generating capacity of tidal power reaches $1.1 \times 10^8 kW$ and there are 242 potential tidal energy dam sites with installed capacity from 200 to 1000kW with total capacity of $12.3 \times 10^4 kW$ and annual energy output of $3.05 \times 10^8 kWh$ [115].

The tidal energy resources are unevenly distributed. The tidal range of the tides along Chinas coast is moderate in the world. In China, East China Sea has the largest tidal range, South China Sea has the least, and Yellow Sea and Bohai Sea fall in between[115]. Estuary mouth of Qiantang River has the most abundant tidal energy.

Chinas tidal energy is mainly distributed along the coast of East China Sea. Fujian and Zhejiang provinces now have the greatest number of potential sites, which are 88 and 73 respectively. Total installed capacity of these sites can reach $1.925 \times 10^4 kW$, with annual energy output of $5.51 \times 10^{10} kWh$, which occupies of 88.3% of the available tidal energy of China. Please refer to Fig.4 for the distribution of tidal energy resources in China.

China has constructed the largest number of tidal power plants in the world. Unfortunately, most of the tidal power plants built from 1958 to 1970s were out of service due to

wrong site selecting, backward technology, conflict service between irrigation and navigation purpose and inconvenience in use. Now only three tidal power plants are in service: Jiangxia pilot tidal power plant is the remarkable one out of those three. It is the third largest tidal power station in the world, with installed capacity of $3.9MW$ [108].

At present stage, the price of tidal electricity is much higher than conventional power and lacks competitiveness due to low energy density, high construction costs and less energy generation. However, Chinese government values the benefits of developing tidal energy, and tries to develop in the ways of seeking advantages and avoiding disadvantages.

The government is very cautious in deciding tidal energy plants construction for historical lessons. Before constructing, sufficient evaluation and thorough advanced planning must be done on site choosing of the barrage, impacts on eco-environments and economic profits.

4.4.2 Marine Current Energy

Marine current energy is the kinetic energy of flowing seawater, and can be extracted from the marine current by ways similar to wind power generation. The higher the speed is, the more valuable an ocean current is. The most exploitable marine current is the tidal current caused by flood and ebb of the seawater. Distribution of marine current energy resources in China is also uneven. Coasts of East China Sea have the most intensive marine current energy resources. According to the statistics of Chinese Academy of Science (CAS), there are about $13,948.5MW$ of tidal current energy technically available in 130 water channels in China. These channels can be divided into three classes. 95 of the 130 channels are located in the coast of East China Sea, which have average power of $10,958.15MW$ theoretically, take 78.6% of the total.

As shown in the Fig.5, the theoretically available reserve of tidal current energy in Zhejiang province is $7090.28MW$, which contributes nearly 50% of the total tidal current energy reserve in China. Taiwan, Fujian, Shandong and Liaoning are ranked from 2nd to 5th.

Chinas marine current energy development technology is going to maturity now. Once technology matured and large scale developed, the cost could reduce to $0.8CNY/kWh$ in estimate[70].

4.4.3 Wave Energy

Wave power is the fast-growing marine energy utilizing method after tidal power. It refers to the kinetic energy and potential energy in waves on ocean surface, and it is the most unstable energy resources. Wave energy resources along Chinas coasts reaches $12852.2MW$.

Taiwan has the most abundant resources, which is $4290MW$. Although there has the most abundant wave energy resources, due to the fact that technological R&D and special financial

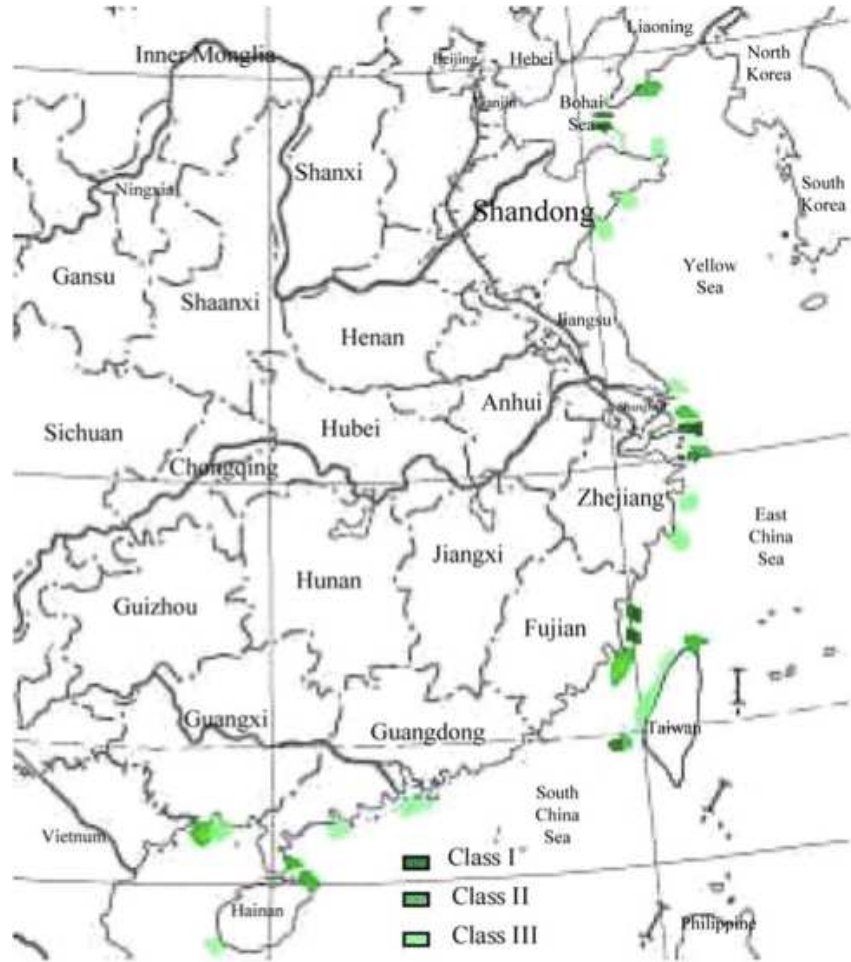

Figure 4.18: Tidal Current Energy Resources Distribution in China[90]

support policies are currently not in place, ocean energy still remains relatively unexplored in Taiwan at present[35]. From the global perspective, wave energy density is low in China, which makes development of wave energy difficult[60].

As indicated in Fig.6, the resources with the highest wave energy density distributed along the central region of Zhejiang, Taiwan, North to Hainan Island in Fujian and Bohai, which can reach $5.11-7.73kW/m$.



Figure 4.19: Wave Energy Resources Distribution in China[90]

Generally speaking wave energy technology in China is immature. The existing wave energy devices in China are still deficient in many aspects, such as high cost, low efficiency, poor reliability, poor stability and small scale [3]. At present, wave power has a high price about 2-3 *CNY/kWh* in China. The wave energy generation system still remained in 10-102*kW* level so far in China. Shortage of the funds also has negative effects on development of wave energy. More support should be given by the government for further maturing of the technology[43].

Chapter 5

Conclusion

Throughout the whole project, it is very obvious that there is a growing concern about running out of the traditional energy resources in the near future, such as oil and coal. All these traditional energy resources are non-sustainable and non-renewable.

Nowadays, seeking out renewable energy resources and developing new advanced technologies for harvesting these renewable energy resources are very crucial. Renewable resources such as solar energy, wind energy and hydropower, etc., all have great potential to solve obstacles we are facing. There are a lot of advantages among using these renewable energy resources, such as reducing greenhouse gases, saving non-renewable energy resources, etc.

However, they are not providing benefits to us all the time. Much land will be used to install solar panels or wind turbines in order to successfully harvesting solar or wind energy. Biofuel is facing the same problem. Biofuel consumes food and takes more land. Another disadvantage is biofuel actually doesn't help reducing the carbon emission. The production of biofuel mostly comes from chemistry industry. The last type of renewable energy resources we investigated is hydropower. Compared with solar energy and wind energy, current is more predictable. In addition, current energy has a large capacity. Therefore it is more stable and can make a continuous supply.

Base on the research and statistics our team gathered, we put our focus on the hydropower as our main recommended alternative renewable energy source. Hydroelectricity is a renewable, non-polluting energy. It does not cause any greenhouse emissions or produce any toxic waste. In addition, hydropower has low operating and maintenance costs. Its life cycle is extremely long. Hydropower can also be used to meet electricity requirements at times of fluctuating demand. Currently it provides more than 87% of all electricity generated by renewable sources worldwide and almost 20% of global electrical capacity. Various technologies are developed to harvest hydropower. Currently modern hydro turbines can convert as much as 90% of the available energy into electricity. Generally speaking, hydropower is the leading sources in renewable energy right now.

However, there are still some obstacles to overcome in the future hydropower development. Hydropower development causes several human and environmental impacts on large

dam-building projects. Although hydropower has no air quality impacts, construction and operation of hydropower dams can still affect natural river systems as well as fish and wildlife populations. The construction of hydropower plants can also alter sizable portions of land. We cannot avoid these kinds of disadvantages, but as the development of new technologies and as the available technologies getting more and more mature, hydropower is still one of the alternative renewable energy resources with the most potential in the future.

Another important fact to be noticed is that it is very expensive to build large and medium-sized dams. Because it usually takes a long time to pay off and become profitable for these hydropower projects, they are facing difficulty in attracting investors. Therefore, the future of hydropower therefore depends to a large extent on the persuasiveness of states and on potential public-private agreements.

In the future, more environmentally friendly ways of using hydropower may be developed. More focus can be put onto developing smaller scale of hydropower project, which utilize tidal and wave energy. In this case, rather than changing it to produce energy, we will focus on using waters natural cycle, thus more environmentally friendly. For increasing the electricity production, there are several ways such as adding new turbines at existing facilities, building new dams, developing small hydro plants or upgrading existing water wheels etc. Overall, our team believes in the bright future of hydropower development.

Bibliography

- [1] Brazil energy efficiency report. Web.
- [2] China's on-grid wind power capacity grows, howpublished=China Daily, month=AUG, year=2012,.
- [3] Chinas wave energy resources. Web.
- [4] Coking coal price spike temporary. Web.
- [5] Composition of fracking fluid.
- [6] Btm forecasts 340-gw of wind energy by 2013. Renewableenergyworld.com, MAR 2009.
- [7] the spanish electricity system: preliminary report 2011, JAN 2012.
- [8] 4.5 - exponential and logarithmic models. Web, OCT 2013.
- [9] Coal and steel. steel production, coking coal. Web, OCT 2013.
- [10] "how much coal is left." - energy explained, your guide to understanding energy. Web, OCT 2013.
- [11] World coal consumption by year. Web, OCT 2013.
- [12] Energy Information Administration. International energy outlook, OCT 2006.
- [13] Energy Information Administration. Annual energy outlook 2012. Web, JUNE 2012.
- [14] Statistic Brain RSS. U.S. Energy Information Administration. Solar energy statistics. Web, JUNE 2013.
- [15] U.S. Energy Information Administration.
- [16] U.S. Energy Information Administration. Annual energy review. Web.
- [17] U.S. Energy Information Administration. Eastern block energy,.
- [18] U.S. Energy Information Administration. Global trade atlas.
- [19] US Energy Information Administration. Annual energy outlook 2013. Web, APR 2013.

- [20] U.S. Energy Information Administration. Energy perspectives: Fossil fuels dominate u.s. energy consumption. Web, DEC 2013.
- [21] Danish Energy Agency. "mnedlig elforsyningsstatistik". summary tab b58-b72, JAN 2012.
- [22] Photovoltaic (Solar Electric). Solar Energy Industries Association. Seia. Web, SEP 2013.
- [23] World Nuclear Association. Outline history of nuclear energy. Web, JUNE 2010.
- [24] World Nuclear Association. Nuclear power in the world today. Web, APR 2012.
- [25] World Nuclear Association. Advanced nuclear power reactors. Web, SEP 2013.
- [26] World Atlas. Hydropower and dams, 2009.
- [27] Tennessee Valley Authority. Hydroelectric power. Web.
- [28] Herbich John B. Handbook of coastal engineering. mcgraw-hill professional, 2000.
- [29] R. Bishop. Tides and the earth-moon system, observer's handbook 2008. Web.
- [30] BP. Natural gas consumption. Web.
- [31] BP. Coal prices. Web, OCT 2013.
- [32] BP. Natural gas reserves. Web, OCT 2013.
- [33] BP.com. Web.
- [34] National Fuel Cell Research Center. "fuel cells explained." fuel cell information: Challenges. Web, OCT 2013.
- [35] Wu CZ Yuan ZH Chang J, Leung DYC. A review on the energy production, consumption, and prospect of renewable energy in china. Renewable and Sustainable Energy Reviews 2003;7(5):45368.
- [36] R. Beardsley Chen and G. Cowles. An unstructured grid, finite-volume coastal ocean model (fvcom) system. special issue entitled advance in computational oceanography". Oceanography, 19 (2006), pp. 78-89.
- [37] "Claverton-Energy.com. Jo abbess, AUG 2009.
- [38] SolarEnergyNet News. CoolerPlanet.com. How photovoltaic cells work, OCT 2013.
- [39] China Electricity Council. statistical bulletin of the national electric power industry-2006, 2007.
- [40] China Electricity Council. statistical bulletin of the national electric power industry-2007, 2008.

- [41] Clean Energy Council. Clean energy australia 2010.
- [42] Global Wind Energy Council. Global wind report annual market update 2012, APR 2013.
- [43] Yonggang L Dahai Z, Wei L. Wave energy in china: current status and perspectives. *Renewable Energy* 2009;34(10):208992.
- [44] David Danielson. A banner year for the u.s. wind industry, AUG 2012.
- [45] Bradley J. Dibble. What the frack is fracking anyway. Web.
- [46] EcoRenovatororg. A brief wind power tutorial, OCT 2013.
- [47] U.S. Energy Information Administration (EIA). Independent statistics and analysis. Web, OCT 2013.
- [48] Alternative Energy. Americas premiere wave power farm sets sail. Web, MAR 2010.
- [49] Data Energy Information and Other Resources. Map of wind farms. Web, OCT 2013.
- [50] C. Hannah F. Dupont and D. Greenberg. Modelling the sea level of the upper bay of fundy. *Atmosphere-Ocean*, 43 (2005), pp. 33-47.
- [51] Solar Energy Facts. Solar energy diagram. Web, APR 2013.
- [52] James Fallows. Eastport, maine: The little town that might. Web.
- [53] Hao Fengshan. Almanac of chinas water power-2005, 2007.
- [54] H. C Fthenakis, V.; Kim. Land use and electricity generation: A life-cycle analysis. *Renewable and Sustainable Energy Reviews* 13, 2009.
- [55] FCT. FuelCellToday. The leading authority on fuel cells. Web, OCT 2013.
- [56] C. Garrett. Tidal resonance in the bay of fundy and gulf of maine. *Nature*, 238 (1972), pp. 441-443.
- [57] D. Greenberg. A numerical model investigation of tidal phenomena in the bay of fundy and gulf of maine. *Marine Geodesy*, 2 (1979), pp. 161-187.
- [58] GWEC. Representing the global wind energy industry., OCT 2013.
- [59] Davor Habjanec. Interesting energy facts: Solar energy facts. Web, SEP 2013.
- [60] Liou HM. Policies and legislation driving taiwans development of renewable energy. *Renew Sustainable Energy Review*, 2010.
- [61] Nick Hodge. Investing in algae biofuel. Web.
- [62] Hannele Holttinen. Design and operation of power systems with large amounts of wind power. *Global Wind Power Conference* 1821, SEP 2006.

- [63] IEA-OES. Annual report 2007.
- [64] IndeMundi. World dry natural gas consumption by year. Web, SEP 2013.
- [65] Smithsonian Institution. A basic overview of fuel cell technology. Web, 2008.
- [66] Inc Investopedia US, A Division of ValueClick. "fracking." definition. Web, SEP 2013.
- [67] P. Wild J. Blanchfield, C. Garrett and A. Rowe. The extractable power from a channel linking a bay to the open ocean, proceedings of the institution of mechanical engineers. Journal of Power and Energy 222 (2008), pp. 289-297.
- [68] Peter Jamieson. Innovation in wind turbine design, 2011.
- [69] Fyall Jenny. 600ft 'sea snake' to harness power of scotland, MAY 2010.
- [70] Han Xueshuang Jiang Qiubiao, Bao Xianwen. Study on the research and development of china's oceanic energy. Ocean Development And Management 2008;25(12):229.
- [71] Benjamin Kallman. The very high temperature reactor. Web, MAR 2013.
- [72] Knoema. Coal prices: Long term forecast to 2020. Web, OCT 2013.
- [73] Martin LaMonica. Bitcoin boom and bust. MIT Technology Review.
- [74] Ben E. Law and Charles W. Spencer. Gas in tight reservoirs-an emerging major source of energy, 1993.
- [75] The leading group of the national countercheck of hydro resources. The countercheck results of hydro resources for the peoples republic of china are formally announced, 2006.
- [76] Eu Legislation. "europa." an energy policy for europe. Web, NOV 2007.
- [77] EU Legislation. "europa." a strategy for competitive, sustainable and secure energy., DEC 2010.
- [78] Zhang Zhi-hui Xu Hong-rui Meng Jie Zhang Rong Liu Fu-you, Zhao Shi-ming. Analysis on research and development of oceanic energy in china. Ocean Technology 2007;26(3):11820.
- [79] Renewable Energy Consulting. Green Rhino Energy Ltd. Solar energy. Web, SEP 2013.
- [80] Triton Consultants Ltd. Canada ocean energy atlas (phase 1) potential tidal current energy resources analysis background. Web.
- [81] Soft Machines. Nuclear vs. solar. Web, AUG 2013.
- [82] Reuters Merrill. Coal prices. Web, OCT 2013.
- [83] Michigan.gov. The energy observer. Web, June 2003.

- [84] Sally Morales, Alex; Bakewell. Wind power seen surging as custom barges cut set-up costs. Bloomberg News. Bloomberg L.P., APR 2012.
- [85] Index Mundi. Brazil total primary energy consumption by year. Web.
- [86] Neeraj. Farming fuels. Web.
- [87] Ecology Global Network. Hydro power in china. Web, 2014.
- [88] IEA. OECD. Other faqs. Web, OCT 2013.
- [89] U.S Department of Energy. Web.
- [90] National Bureau of Statistics of China. China energy statistical yearbook-2008, 2008.
- [91] OMC. Billions without power. Web.
- [92] Keith Orchison. Wave of the future needs investment, OCT 2010.
- [93] Algae Biomass Organization. 2013 industry survey - executive summary. Web.
- [94] Mukund R. Patel. Wind and solar power systems design, analysis and operation, 2006.
- [95] William Pentland. Maine takes tidal power to next level. Forbes Magazine, Apr. 2012.
- [96] Frequently Asked Questions About Solar Photovoltaic and Solar Thermal (Hot Water) Systems. California Public Utilities Commission. Frequently asked questions about solar photovoltaic and solar thermal (hot water) systems. Web, OCT 2013.
- [97] Mike Postma. Bay of fundy tides: The highest tides in the world! Web.
- [98] Pelamis Wave Power. First electricity generation in portugal.
- [99] Wang Qingyi. Present condition, obstacle and measures for china renewable energy. Energy China 2002; 8: 357.
- [100] Quora. Hydraulic fracturing: What are the pros and cons of 'fracking'? Web, OCT 2013.
- [101] REN21. Renewables 2011: Global status report.
- [102] BP Statistical Review. Iea world energy outlook 2009. Web, 2009.
- [103] Texas A&M University Robert H. Stewart, Department of Oceanography. Wind driven ocean circulation.
- [104] AWEA Director of Industry Salerno, E. and Data Analysis. Cost of wind power kicks coal's butt, better than natural gas. CleanTechnica.com, 2011.
- [105] ScienceDaily. Web, DEC 2013.
- [106] SEN. Monthly statistics, JAN 2012.

- [107] McClosky Coal Information Service. Web.
- [108] SINOPEC. Experts in advanced energy technology field of national high-tech r&d program of china (863 program). introduction of development of advanced energy technology in china, 20130.
- [109] Clean Technica. Us reaches 50 gw of wind energy capacity in q2 of 2012, AUG 2012.
- [110] 1. R. Bishop Tides. Tides and the earth-moon system, observer's handbook 2008. Web, SEP 2013.
- [111] Tufts University Tufts Now. How can we effectively store solar energy? Web, MAY 2013.
- [112] World Market Update. Btm consult (2009). international wind energy development, 2009.
- [113] UPI. Eu wind power capacity reaches 100gw, OCT 2012.
- [114] .V.Singh. What is conventional source of energy? Wall Street Journal, DEC 2013.
- [115] Lu W Wang CK. Analysis methods and reserves evaluation of ocean energy resources. Beijing: Ocean Press, 2009.
- [116] Shi WY Wang CK. The ocean resources and reserves evaluation in china. 1st national symposium on ocean energy in Hangzhou. 2008. p. 16979.
- [117] Wikipedia. Albert betz. Web.
- [118] Wikipedia. Coal in australia. Web.
- [119] Wikipedia. Energy policy of australia. Web.
- [120] Wikipedia. Final consumption expenditure. Web.
- [121] WikiPedia. Nabucco pipeline.
- [122] Wikipedia. Tip-speed ratio. Web.
- [123] Wikipedia. Trade wind. Web.
- [124] Wikipedia. U.s. 2012 installed wind power capacity. Web.
- [125] Wikipedia. Wind power.
- [126] WikiPedia. World energy resources and consumption.
- [127] Colin Woodark. Maine company leading way as tidal energy comes of age.
- [128] Hermann M. Fritz Xiufeng Yang, Kevin A. Hass. Ocean current energy assessment for the gulf stream. 4th Annual Marine Renewable Energy Technical Conference, OCT 2012.

- [129] Li Yunwu. Ocean energy resources development. beijing: Ocean press. Web, 2008.
- [130] Tian Zongwei Zhou Shuangchao. Chinas hydro resources are the richest in the world-summary of the national countercheck of hydro resources, 2005.