



WPI

Pinion Process Improvement at Primetals Technologies

Major Qualifying Project Submitted to the Faculty of

WORCESTER POLYTECHNIC INSTITUTE

In Partial Fulfillment of the Requirements for the Degree of Bachelor of Science

February 28, 2017

Submitted by:

Emily Aldrich
Elizabeth Bernier
Serra Onder
Molly Rockwood
Jonathan Viens

Sponsor:

Primetals Technologies USA LLC

Advisors:

Walter T. Towner, Jr. Ph.D.
Helen Vassallo Ph.D.
Torbjorn Bergstrom Ph.D. Candidate

Table of Contents

1. Abstract	6
2. Acknowledgements	7
3. Executive Summary	8
3.1 Introduction	8
3.2 Background	8
3.3 Methods	9
3.4 Results and Discussion	10
4. Introduction	11
4.1. Problem Statement	11
4.2. Project Goals and Objectives	12
4.3. Project Deliverables	12
4.4. Project Scope	13
4.5. Project Timeline	13
5. Background	14
5.1. Primetals Technologies	14
5.1.1 Morgan Construction Company	14
5.1.2 Siemens AG/Siemens VAI Metal Technologies	14
5.1.3 Mitsubishi	15
5.1.4 Primetals	15
5.2. Pinion Manufacturing and Applications	15
5.3. Purposes of Gages in Manufacturing	16
5.4. Lean Manufacturing	17
5.4.1 5S	18
5.4.2. Waste in Lean	18
5.5. Axiomatic Design	19
6. Methods	20
6.1 Understanding the Current State	20
6.2 Modeling the Current State	22
6.3 Developing Solutions for WWC1	22
6.3.1 Identifying and Reducing Waste	22
6.3.2 Opportunity for Standardization of Tools in the Work Space	29
6.3.3 Decoupling the Process Steps	30

6.4. Strategy for Implementing Solutions at WWC1.....	31
6.5. Financial Analysis Methods	31
7. Results	33
7.1 Process Analysis and Implementation of Solutions	33
7.2 Variable Adjustment Inspection Gage.....	40
7.3 Financial Analysis	43
8. Discussion	46
8.1 Challenges Encountered	46
8.2 Tolerance Analysis of Variable Adjustment Gage.....	47
8.3. Gage Design Failure Analysis	58
8.4. Interdisciplinary Collaboration	60
9. Conclusions.....	61
10. Future Recommendations	62
11. Appendices.....	63
11.2. Appendix B: Axiomatic Design	65
11.3. Appendix C: 5S Audit Sheet	68
11.4. Appendix D: Standard Work.....	69
11.4.1. Center Hole Grinding Standard Work	69
11.5. Appendix E: Gage Design	71
11.6. Appendix F: Presentation	75
12. References.....	79

Table of Figures

Figure 1: Cycle Time for Every Step in Primetals Pinion Process	11
Figure 2: Process Improvement Timeline Overview Gantt Chart	13
Figure 3: Termly Breakdown of Project Objectives by Academic Term	20
Figure 4: Spaghetti Diagram of Current Transportation Pattern for WWC1.....	23
Figure 5: Current Process for Finding a Job in Bay 8 Inventory Management System	25
Figure 6: Portable Light used in Chuck Jaw Removal	26
Figure 7: Chuck Jaw Storage	27
Figure 8: Chuck Jaw Storage in Workstation Layout.....	27
Figure 9: Gage Inventory Management System at WWC1	30
Figure 10: Old Transportation for WWC1.....	33
Figure 11: New Transportation for WWC1	34
Figure 12: Old Inventory Management System.....	34
Figure 13: New Inventory Management System	35
Figure 14: Chosen Light for Danobat: Grainger Model 5RHN0 (Grainger, 2017).....	35
Figure 15: Before and After Chuck Jaw Location	36
Figure 16: Impact on WWC1 Pinion Cycle Time Before and After Solutions	38
Figure 17: Impact on WWC1 Pinion Setup Time Before and After Solutions	39
Figure 18: Gage Design Notes	40
Figure 19: AutoCAD Rendering of Universal Gage.....	41
Figure 20: Gage Prototype Design.....	41
Figure 21: Old Snap Gage.....	42
Figure 22: Financial Impact of Solutions.....	44
Figure 23: Pinion Drawing.....	48
Figure 24: Outer Diameter Dimension Label Reference Diagram	49
Figure 25: Graph Tolerance Differential of Pinions vs Tolerance Differential of Variable Adjustment Gage Dial Indicator	52
Figure 26: Graph of Differential Tolerance Comparison	55
Figure 27: Comparison of Tolerance Differentials throughout Calculations	56
Figure 28: Starrett Dial Indicator Percentage of Accuracy in Relation to Pinion Tolerance	56
Figure 29: Process Performance Comparison on Specification Limits	58
Figure 30: Visual Breakdown of Total Cycle Time for One Pinion on WWC1.....	63
Figure 31: Total Cycle Time for One Pinion on WWC1 by Task Category	63
Figure 32: Total Setup Time for One Pinion on WWC1 by Task Category.....	64
Figure 33: Axiomatic Design Model of the Current State of WWC1	65
Figure 34: FR-DP Dependency Matrix of Current State of WWC1.....	65
Figure 35: Axiomatic Design Model of Proposed State of Outer Diameter Grinding	66
Figure 36: FR-DP Dependency Matrix of Proposed State of Outer Diameter Grinding.....	66
Figure 37: Axiomatic Design Model of Proposed State of Center Grinding.....	67
Figure 38: FR-DP Dependency Matrix for Proposed State of Center Grinding.....	67

Figure 39: 5S Audit Sheet.....	68
Figure 40: Variable Adjustment Gage Frame Piece A & Figure 41: Variable Adjustment Gage Frame Piece B	71
Figure 42: Variable Adjustment Gage Pieces Side by Side.....	72
Figure 43: L9 Alloy Hex Nuts	72
Figure 44: Socket Head Cap Screws.....	73
Figure 45: Tensile Strength Vs. Density of Aluminum (Red) & Steel (Blue).....	73
Figure 46: Fracture Toughness Vs. Hardness of Aluminum (Red) & Steel (Blue).....	74
Figure 47: Specific Heat Vs. Thermal Expansion of Aluminum (Red) & Steel (Blue)	74
Table 1: Identified Wastes from Manufacturing in System.....	28
Table 2: Summary of Identified Waste by Type of Waste in System	29
Table 3: Summary of Changes and Solution Impact	37
Table 4: Summary of Changes and Solution Impact by Waste	37
Table 5: Solution Cost Breakdown	44
Table 6: Calculations for Financial Analysis under Fully Loaded Conditions.....	44
Table 7: Required Pinion Tolerances.....	50
Table 8: Measured Dimensions vs. Required Dimensions for Pinions	50
Table 9: Tolerance Differential of Pinions vs the Starrett Dial Indicator	52
Table 10: Calculated Tolerances on Starrett Dial Indicator.....	53
Table 11: Differential Tolerances of Pinion vs. Differential Tolerances of Starrett Dial Indicator.....	54
Equation 1: Formulas to Calculate Quarterly Cash Flow Increases	31
Equation 2: Calculation of Tolerance Differential.....	51
Equation 3: Calculation of Tolerance Differential.....	51
Equation 4: Equation to Determine Gage Use at WWC1	51
Equation 5: Calculation of Accuracy for the Starrett Gage	51
Equation 6: Formula to Determine Process Bias toward Lower Specification Limits	57
Equation 7: Formula to Determine Process Bias toward Upper Specification Limits	57
Equation 8: Process Capacity Equation	57

1. Abstract

The objective of this Major Qualifying Project (MQP) was to reduce Primetals' cycle time and setup time for pinions at workstation WWC1 by 20%. WWC1 was identified by Primetals as the bottleneck in their value stream for pinion manufacturing, with a processing time over twice as long as every other step in the process. The team applied lean manufacturing techniques to reduce waste at WWC1. Additionally, the team designed and manufactured a custom gage, a crucial tool for the WWC1 workstation. These combined solutions resulted in a 16% decrease in total cycle time per pinion at the workstation. The reduction in setup time derived from the team's solutions was over 37% per pinion. This total reduction in cycle time aided in relieving the bottleneck at WWC1 resulting in Primetals being capable producing 120 more pinions per year. Assuming there is a demand for those 120 additional pinions, this could increase potential pinion sales revenue by as much as \$1,200,000 per year without increasing labor and machine availability.

2. Acknowledgements

We would like to thank Primetals Technologies and Worcester Polytechnic Institute (WPI) for the opportunity to conduct research and solution implementation in the field, as well as for Primetals' unwavering support and welcoming attitude toward process improvement. The following individuals have contributed greatly toward the project, so we would like to thank them explicitly:

Alberto Ortega- Lean Manufacturing Manager

Walter Towner- Project Advisor

Helen Vassallo-Project Advisor

Torbjorn Bergstrom- Project Advisor

Shane Bell- Higgins Laboratories Lab Monitor

Primetals WWC1 Machine Operators- Danobat and Studer Machine Day and Night Shift Operators

Additionally, we would like to acknowledge the Industrial Engineering and Mechanical Engineering departments for allowing the collaboration required to pursue a hands on process improvement project in the field of manufacturing.

3. Executive Summary

After a time study and value stream analysis were conducted by MassMEP in the summer of 2016, Primetals concluded that pinion outer diameter grinding at the WWC1 workstation was a bottleneck step in the pinion manufacturing process. This MQP team set out to relieve this bottleneck through reduction of waste from non-value added time, as well as improving various processes for simplicity and operator safety.

3.1 Introduction

Primetals Technologies in Worcester, Massachusetts produces capital equipment for the steel and wire rolling industry world-wide. Primetals partnered with Worcester Polytechnic Institute (WPI) to sponsor a capstone Major Qualifying Project (MQP) aimed to improve the manufacturing process of pinions at the WWC1 workstation. The goal of this MQP was to alleviate the bottleneck in the Primetals pinion production process located at WWC1 through lean process improvement methods and mechanical engineering design solutions. The success of this MQP was evaluated by Primetals using the following key performance indicators (KPIs):

- Cycle time reduction by 20% per pinion on workstation WWC1
- Setup time reduction by 20% per pinion on workstation WWC1
- Standardization of tools and processes implemented at workstation WWC1
- Tolerance analysis of a universal gage design (Variable Adjustment Gage)
- Full documentation of the cost/benefit of solution.

3.2 Background

Primetals Technologies was created by a joint venture between Mitsubishi-Hitachi Metals Machinery and Siemens VAI Metals Technologies in 2015. Primetals is the current industry leader in metallurgical plant solutions (Primetals Technologies, 2016). The Primetals facility this MQP team worked with is located in Worcester, Massachusetts.

The bottleneck workstation targeted by this project is a pinion grinding workstation. A pinion is a gear with a small number of teeth which engages with a rack or larger gear (Joshi, 2016). At its most basic level, pinions apply rotational motion to a rack or larger gear which translates into linear motion (Maxim, E. A., 2011). The manufacturing of a pinion starts with a

plain steel rod.(Johnson, T. G., 2010). The pinion manufacturing process involves at least two outer diameter (OD) grind operations as well as using a bit feeding into the rod perpendicularly to create the gear teeth. Precision is key in pinion manufacturing, as all dimensions must be within specific tolerances for it to operate properly. (Johnson, T. G., 2010).

Gages are high precision, indirect measuring instruments that compare the product being manufactured to a standard. Gages do not take measurements of the actual product, but the deviation of the measurement from the standard. Gages are commonly used to reduce the non-value added time of inspection (Philips, 2014).

Lean manufacturing is a process improvement tool used to decrease waste in a production process as well as improve customer value. Waste can be defined as anything that does not add value for the customer. Research conducted by the Lean Enterprise Research Center (LERC) shows that approximately sixty percent of production activities in a typical manufacturing process do not add value for the customer (LERC, 2016). 5S is a lean manufacturing strategy employed by business managers and improvement teams, which helps to identify and eliminate waste and improve process reliability.(Lean Manufacturing Tools, 2016).

3.3 Methods

This project was proposed to a team of four industrial engineering students and one mechanical engineering student, each team member having various levels of comfort in a manufacturing setting. All of the members in the team developed a strong understanding of the pinion manufacturing processes, grinding operations on the machines in the WWC1 station, and the Primetals' company culture.

The team conducted an extensive investigation of pinion manufacturing, industry techniques and practices, as well as Primetals procedures. The time study information gathered, summarized in Appendix A, helped the team to understand exactly what was happening at WWC1 when manufacturing pinions, and helped to model the current state.

In the analysis of the current state of the WWC1 workstation, the team used the Axiomatic Design method to determine any waste due to unwanted coupling of functional requirements and design parameters. The resulting axiomatic design decomposition, shown in

Appendix B, displays sequential coupling between the center grinding machine and the Danobat outer diameter grinding machine.

The team developed a 5S audit sheet to evaluate the success of a previous 5S project that had been implemented at WWC1. The sheet assisted the team in targeting areas for improvement. Once target areas were identified, the team worked to find evidence of the seven lean manufacturing wastes present at WWC1. The team identified transportation, inventory, motion, and over processing as wastes present at WWC1. An opportunity to standardize tools in the workspace was also uncovered when identifying waste. The team utilized the design process skills of the Mechanical Engineer to develop a new standardized gage for measuring pinions. The Axiomatic Design decomposition assisted the team in identifying process steps that could be decoupled from the WWC1 standard work and run parallel to the Danobat.

3.4 Results and Discussion

After identifying wastes from manufacturing present at WWC1, the team worked to develop solutions to reduce, and in some cases eliminate, the wastes. The team eliminated transportation waste per pinion by decoupling the center grinding process step from the standard work of WWC1. The team implemented a system where the underutilized Bay 8 operator would perform the center hole grinding operation parallel to the grinding operations on the Danobat in WWC1. The team also implemented a new inventory management system to reduce the time it takes to queue the next job for WWC1. This solution also freed up 654 square feet of space for Primetals to be utilized for other value-added tasks. The team reduced waste caused by motion by optimizing the location and tool type for selected tools in the workstation. Lastly, the team reduced the risk for defect by standardizing the units of measurements for pinions. Removing these wastes from the system reduced cycle time by 16% and set up time by 37%.

The mechanical engineer of the MQP team designed a universal gage. AutoCAD was the primary tool for rendering the design of the gage which was then manufactured in collaboration with WPI Washburn Shops and Primetals. The gage improvements were manufactured in Washburn shops using a discontinued snap gage from Primetals. This acted as a low cost solution to satisfy the need for a universal gage in WWC1.

4. Introduction

Primetals Technologies in Worcester, Massachusetts produces capital equipment for the steel and wire rolling industry world-wide. Primetals partnered with Worcester Polytechnic Institute (WPI) to sponsor a capstone Major Qualifying Project (MQP) aimed to improve the manufacturing process of pinions at the WWC1 workstation. The goal of this MQP was to reduce cycle and setup time at the workstation by 20% through Lean process improvement methods and mechanical engineering design solutions.

4.1. Problem Statement

Primetals' process for manufacturing pinions causes long lead times for customer orders and a backlog of parts waiting to be processed. A value stream mapping project conducted by MassMEP in July, 2016 identified the WWC1 workstation as a target rich environment for pinion manufacturing process improvement. This stations was selected largely due to its long cycle time in the pinion making process (Figure 1 (MassMEP, 2016)).

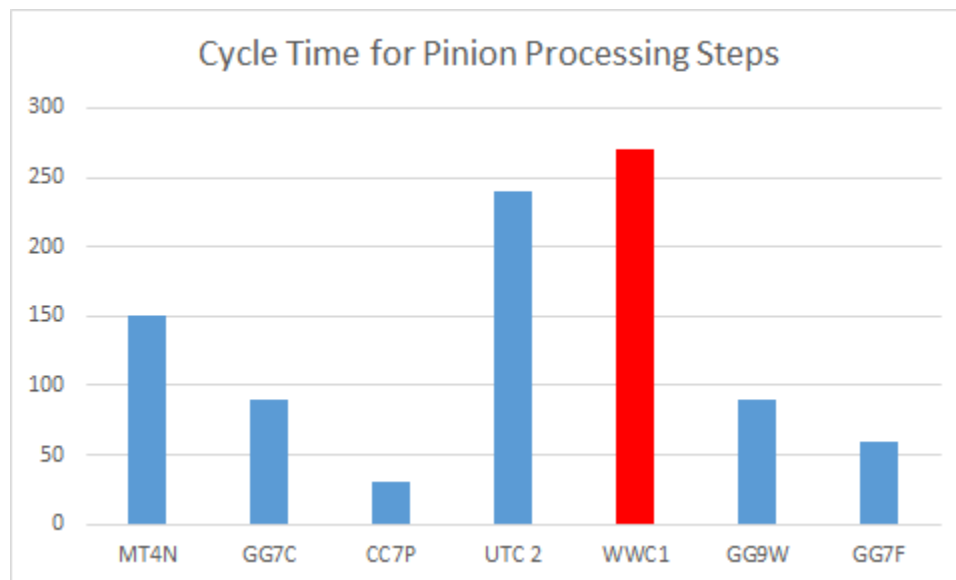

Figure 1: Cycle Time for Every Step in Primetals Pinion Process

This project aimed to reduce waste in WWC1 by evaluating the workstation on the following criteria: work center improvement, workstation design, layout, fixture design, tooling methods, and ergonomics.

4.2. Project Goals and Objectives

The goal of this project, as requested by Primetals, was to develop a solution that would reduce the cycle time and setup time of the workstation each by 20% for pinion processing. The team used axiomatic design and lean manufacturing methods to determine areas of improvement. Using axiomatic design allowed the team to identify the functional requirements, design parameters, and constraints surrounding the manufacturing process. Data was collected to develop an axiomatic design decomposition through both direct observations of the workstation on the manufacturing floor and personal interviews with the machine operators, scheduling managers, and floor managers. The industrial engineering team members collaboratively designed process solutions while the mechanical engineering team member designed any needed tools. Once the solutions were implemented on the manufacturing floor, a financial and throughput analysis was conducted to evaluate the success of the solutions.

The success of this MQP was evaluated by Primetals using the following key performance indicators (KPIs):

- Cycle time reduction by 20% per pinion on workstation WWC1
- Setup time reduction by 20% per pinion on workstation WWC1
- Standardization of tools and process implemented at workstation WWC1
- Tolerance analysis of Variable Adjustment Gage
- Full documentation of the cost/benefit of solution

4.3. Project Deliverables

The project deliverables included implementing the newly designed standard work at the WWC1 workstation, financial analysis of the improvements, as well as a universal inspection gage for measuring pinions' outer diameters.

4.4. Project Scope

The team was focused primarily on workstation WWC1. Although there are two machines in the WWC1 manufacturing cell, the Danobat and the Studer, the team focused solely on the Danobat, as that is the primary machine used for all pinion outer diameter grinding. All steps in the pinion production process outside of this workstation were considered out of the scope of this project. The project looked at ways that waste could be eliminated, particularly using axiomatic design and lean manufacturing methods.

4.5. Project Timeline

The time frame for completing this MQP was from the beginning of A-Term, August 25, 2016, to the end of C-Term, March 3, 2017. The project was broken down into deadlines displayed in our Gantt chart (Figure 2). Figure 3, as a part of Section 6: Methodology, displays a structured termly breakdown of the project based on the main objectives for each academic term. The first seven weeks were spent gathering data. The next seven weeks were spent analyzing the data, proposing, and implementing solutions. As requested by Primetals, the bulk of the project research, development, and implementation was completed by the end of December, 2016, in order to devote time during C-Term for analysis and our sponsor presentation.

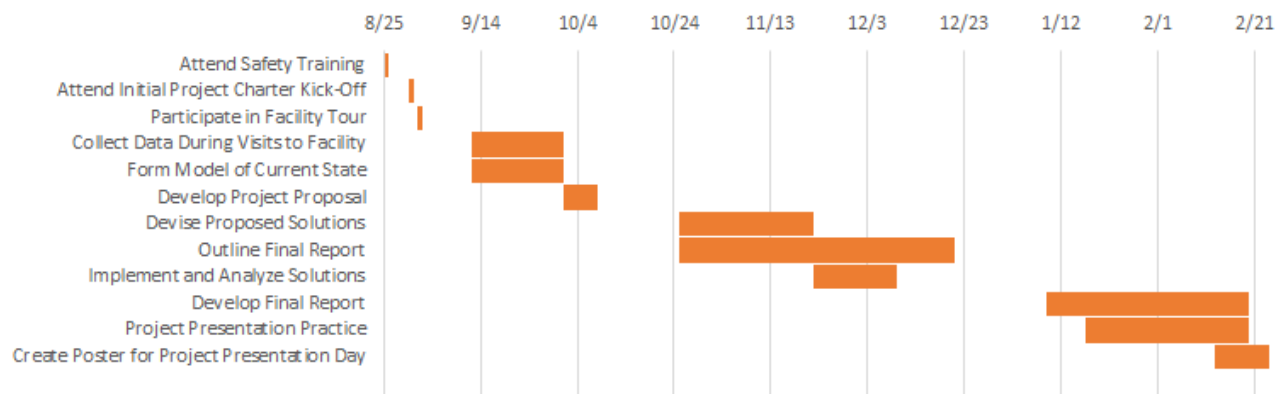

Figure 2: Process Improvement Timeline Overview Gantt Chart

5. Background

The MQP team conducted research on Primetals Technologies' history, pinion manufacturing and applications, purposes of gages in manufacturing, lean manufacturing and axiomatic design in order to understand the problem fully and implement a solution.

5.1. Primetals Technologies

Primetals Technologies is located in Worcester, Massachusetts. The company was previously known as Morgan Construction Company, later acquired by Siemens AG/Siemens VAI Metal Technologies, and then Mitsubishi (Primetals, May 2015).

5.1.1 *Morgan Construction Company*

Morgan Construction Company was founded in 1888 by Charles Hill Morgan in Worcester, Massachusetts. The company was focused on wire rod rolling-mill equipment with a patented "Reducing/Sizing Mill" technology. (Simon, 2008). It was the primary supplier of wired rod rolling-mill equipment for many years. Due to the Morgan Construction Company's outstanding reputation in the rolling equipment field, Siemens AG/Siemens VAI Metal Technologies bought Morgan Construction Company in 2008 in an effort to increase its capability of producing mill equipment in the global market (Simon, 2008).

5.1.2 *Siemens AG/Siemens VAI Metal Technologies*

Siemens AG was established by Werner von Siemens, in Berlin, Germany in 1847. The company offers a broad range of products and services in a multitude of industries. (Siemens, 2016). The company has approximately 348,000 employees globally. In the fiscal year of 2015, Siemens AG had a revenue of €75.6 billion. (Siemens, 2016).

Siemens VAI Metal Technologies is a metallurgical industry that was partnered with Siemens AG in 1995. In 2015, Siemens VAI Metal Technologies entered a joint venture with Mitsubishi Heavy Industries with a 51% of the joint venture owned by Mitsubishi and 49% owned by Siemens. This new partnership would provide Mitsubishi production plants, products, and services for the metals industry (Primetals, 2016).

5.1.3 *Mitsubishi*

Mitsubishi was founded in 1870 as a shipping company. Throughout the years, Mitsubishi was expanded to other industries. In 1916, Mitsubishi was transformed into a leader in machinery and electrical equipment. Mitsubishi Headquarters was dissolved and most of the Mitsubishi companies divided into several independent enterprises in 1946 (Mitsubishi, 2016). Three major companies maintain the responsibility to oversee enterprise operations. They are: Mitsubishi Bank, Mitsubishi Corporation, and Mitsubishi Heavy Industries (Manufacturing Capacity Simulation at Primetals Technologies, 2016).

Mitsubishi Heavy Industries was founded in 1884, divided into three branches in 1950, then later consolidated back to one in 1964. Major products and operations are Energy & Environment, Commercial Aviation & Transportation Systems, Machinery, Equipment & Infrastructure, and Integrated Defense & Space Systems. The total number of consolidated employers were recorded as 81,845 in March 2015. There are 240 group companies within Mitsubishi Heavy Industries as of March 2015 (Mitsubishi Heavy Industries, 2016).

5.1.4 *Primetals*

Primetals Technologies was created by a joint venture between Mitsubishi-Hitachi Metals Machinery and Siemens VAI Metals Technologies in 2015. There are approximately 7,000 employees in the company and more than 300 group sites located in 190 countries. The company specializes in Iron and Steelmaking, Mini Mill and Long Rolling, C Metallurgical Services, and Electrics and Automation. Primetals is the current industry leader in metallurgical plant solutions (Primetals, 2016).

5.2. **Pinion Manufacturing and Applications**

The definition of a pinion is a gear with a small number of teeth which engages with a rack or larger gear (Joshi, 2016). At its most basic level, pinions apply rotational motion to either a rack or larger gear which translates into linear motion. An example of this is the use of pinions to assist railcars up steep slopes by engaging with a rack between the rails. However, there are a multitude of applications and systems in which pinions can be used (Maxim, 2011).

Three main types of systems in which pinions are used in are epicyclic gearing, pinion and rack, and differential drive. Epicyclic gearing is when a smaller gear is placed within an

annular gear and rotates around the interior diameter of the annular gear (Bostock, 2017). It is generally used for automotive processes such as in automatic transmissions and overdrives, due to the always constant-mesh, smooth and quiet application of brake bands, and considerable variation in gear ratios (Bostock, 2017).

The manufacturing of a pinion is a long and slow process starting with a plain steel rod. An industrial lathe is important in the manufacturing of the pinion (Johnson, 2010). The first step in the process is grinding down one side of the steel rod to the dimensions required for future pinion use. This can vary depending on the size and function of pinion being manufactured. The next step is to craft the individual teeth of the pinion. This step is performed on the middle section of the steel rod, which, in most cases, is located after the section of newly ground steel rod. To create the teeth, a bit with angled teeth, similar to a power saw, is used. This bit then approaches the rod perpendicularly, creating the grooves between each tooth of the pinion. This is the longest processing time of the pinion manufacturing process due to the rotation of the rod during the process in order to achieve the correct spacing between each pinion tooth. To complete the pinion, the section of rod located behind the pinion teeth is grinded down to the correct dimensions for pinion use. Once all the dimensions are correct, the excess steel can be cut off (Johnson, 2010).

5.3. Purposes of Gages in Manufacturing

When manufacturing any product, the result should be compared with customer requirements for quality. The product should meet custom specifications, when evaluated from the first step in the manufacturing process to the finished product. Throughout this evaluation process, the measurements gathered should have a standard unit for clarity and simplicity. These units are well known by the operators, inspectors, and quality assurance departments' interacting with the product (Philips, 2014).

Gages are considered indirect measuring tools, which are used to compare the manufactured product to a specific standard instead of direct measurement of the product. The standard, also referred to as a "master," is a precision object that represents multiple measurements on a product. Gages compare the deviation in measurement of the master to the manufactured product to determine its OD. In other words, if a gage measures 0, it is the same

size as the master, meaning there is no deviation and production may proceed. All designs will have tolerances that define the maximum and minimum a product is allowed to deviate from the master (Philips, 2014).

Gages are designed for a specific task. Having an effective gage in the workplace often decreases inspection time because gages measure more quickly than calipers, rulers, or scales. The inspection is more necessary 'non-value-added' time in the manufacturing process. Gages are commonly used in order to reduce this non-value added time. They are also considered higher precision tools than many other measurement tools (Philips, 2014).

There are two general classifications of gages: hard and variable. Hard gages perform numerical measurements and produce defined numbers. They can be used for inside and outside diameters and holes. Variable gages measure whether a part is within tolerance specifications or "good" or outside of tolerance specifications or "bad." It does not measure by how much it is outside of tolerances. Though variable gages are often faster than hard gages, they are not good options for manufacturing floors where inspection is done by the operator at the source (Philips, 2014).

5.4. Lean Manufacturing

Lean manufacturing is a process that seeks to decrease waste in a production process as well as improve customer value (Lean Enterprise Institute, 2016). Waste can be defined as everything that does not add any value for the customers. The Lean Enterprise Research Center (LERC) found that approximately sixty percent of production activities in a typical manufacturing process do not add value for the customers (Lean Enterprise Institute, 2016). Reducing the waste in the manufacturing process is critical. There are several lean tools that can be applied to decrease waste through Kaizen, a Japanese word for "change for the better" or "good change" (12 Essential Lean Concepts and Tools, 2013). Some of these tools are Pull System (Kanban), Five Why's, Poka Yoke (Error Proofing), 5S, Just-In-Time (JIT), Continuous Improvement, Bottleneck Analysis, Root Cause Analysis and Value Stream Mapping (Lean Production, 2016).

5.4.1 5S

5S is a lean manufacturing strategy employed by business managers and improvement teams, which helps to identify and eliminate waste while improving process reliability. It is defined by the five Ss: Sort, Set-in-Order, Shine, Standardize, and Sustain. Recently Safety was added as a sixth S to include ergonomical aspects of process improvement (Lean Manufacturing Tools, 2016).

Sorting takes place first, and is a critical step to reducing the number of tools in the work space. It involves inventory classification and a “red tag campaign,” in which rarely used, damaged, or obsolete items and tools are removed from the system. Set-in-Order is the next step, where tools are placed in logical locations based on frequency of use. This eliminates time wasted by operators searching for tools. Workplaces where operators spend thirty seconds or less looking for parts are considered to meet the “gold standard.” The third step of 5S is Shine. This step requires that guidelines are implemented for cleaning activities, which translates to decreased machine breakdowns, increased safety, and better quality products. Standardize refers to creating best practices. This includes anything from visual aids to work instructions, both of which help operators and outsiders to understand the system without much knowledge of the process or machines. Sustain is where plans for future audits are created to maintain improvement longevity. Finally, Safety includes observing the system and developing solutions that keep the safety of operators and other floor workers in mind. This could be changing bench height to decrease back injuries from hunching, or upgrading lifting equipment to reduce physical strain. These safety steps make a difference in the capacity at which an operator can work (Lean 6S; 5S+Safety, 2016).

5.4.2. Waste in Lean

Taiichi Ohno, founder of Toyota Production System (TPS), identified seven wastes in an unproductive manufacturing process that do not add any value (Kaizen Institute, 2015). These wastes are:

- Transportation: Moving of people, products, or information.
- Inventory: Storing of parts or documentation ahead of requirements for production.
- Motion: Bending, turning, reaching, or lifting.

- Waiting: For parts, information, instructions, equipment, or processes.
- Over Production: Making more than customer demand.
- Processing: Making higher quality than required.
- Defects: Rework, scrap, or incorrect documentation.

Eliminating these wastes can help a system operate at full capacity and increase throughput, in turn, increasing profits for the company (Kaizen Institute, 2015).

5.5. Axiomatic Design

The Axiomatic Design method was invented by Dr. Nam Suh at Massachusetts Institute of Technology and published in the 1990s (Suh, 1990). Axiomatic Design uses the following to model a system or process: Functional Requirements (FRs), defined as the actions or goals that a process must complete, and Design Parameters (DPs), known as the physical attributes used to accomplish the FRs. FRs can many times be defined by Customer Needs (CNs). However, CNs can also drive Constraints in the system, which limit the ability for change and improvement in the model.

FRs are mapped directly to corresponding DPs in a matrix to display the interaction between the two. Any coupling found in the matrix-- instances where FRs are related to DPs of another FR and vice versa-- is then identified as an area for improvement. Improvements are made following two basic guidelines, or axioms: (1) maximize independence and (2) minimize information. Maximizing independence between all of the FRs and DPs ensures that there will be little non-value added iterations and waste due to redundancy. For example, a sink with separate knobs for hot and cold water has coupling between the DPs; it takes a lot of adjustment to get temperature and flow rate correct (Brown, 2013). Minimizing information ensures a robust and easy-to-understand design, increasing the likelihood that the design will fulfill its FRs. Additionally, unnecessary information is not being transferred to people or steps which do not require it. An ideal solution will follow these axioms to the highest degree possible given the system's constraints.

6. Methods

The project and methods used took place over the course of three academic terms at WPI, each seven weeks in duration. Figure 3 shows the procedure for developing and implementing the solution aimed to reduce the cycle time of pinions at WWC1. Each step in the procedure was completed in one academic term, as permitted by machine maintenance and operations scheduling.

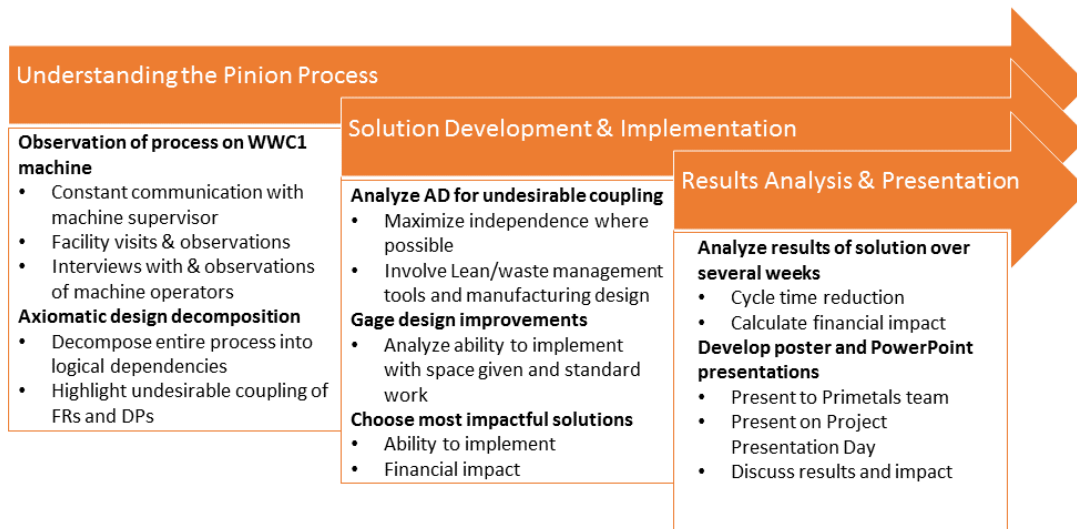

Figure 3: Termly Breakdown of Project Objectives by Academic Term

6.1 Understanding the Current State

This project was proposed to a team of one Mechanical Engineering and four Industrial Engineering students with various levels of comfort in a manufacturing setting. The focus in the first term of this MQP was for all of the members to develop a strong understanding of the pinion manufacturing processes, grinding operations on the machines in the WWC1 station, and the Primetals' company culture.

Developing the knowledge needed to complete this project began with each team member researching the pinion manufacturing process. This was done by investigation of industry techniques and practices as well as exploring documents provided to the team by Primetals. The team then worked with Alberto Ortega, Senior Lean Manufacturing Manager, to perform a

physical walkthrough of the value stream map for pinion manufacturing at Primetals. This exercise allowed the team to apply the industry research on pinion manufacturing to the Primetals factory to truly understand each step in the process for their unique pinion manufacturing process.

The team also researched the machines and tools used at WWC1. This allowed the determination of what steps inside WWC1 were realistic to change. It also allowed the team to identify the value added tasks being performed within the station. This was important in determining what steps were dependent on each other for the successful production of a pinion. It was also useful in helping the team approach the problem with an unbiased, informed, perspective. Once the team understood the purpose and process of the machines and tools at WWC1, over sixty hours of time studies, managerial interviews, operator interviews, and real-time observations were conducted at Primetals. The information gathered (summarized in Appendix A) helped the team to understand exactly what was happening at WWC1 when manufacturing pinions, and begin to model the current situation.

Understanding the company culture was the last, and, arguably, most important, step in understanding the current state of pinion manufacturing of WWC1. The team aimed to learn the following:

- Operators acceptance to change
- Management's acceptance to change
- Communication between operation and management.

The team determined they would need to have a complete understanding of these three things in order to successfully implement any solutions they developed. Close relationships were developed with the two operators for WWC1 as well as with Primetals management. The team worked directly with WWC1 employees in order to fully comprehend how employees interact with each other, understanding the process, and establishing a trusting relationship with them.

Once the team had developed a well-rounded understanding of pinion manufacturing at WWC1, a model was developed to target problems in the current process.

6.2 Modeling the Current State

In the analysis of the current state of the WWC1 workstation, the team used Axiomatic Design to reveal any waste due to unwanted coupling of functional requirements and design parameters. Our axiomatic design decomposition, (Appendix B), displays sequential coupling between the center grinding machine and the Danobat outer diameter grinding machine. In manufacturing, sequential coupling is generally an unavoidable fact. The team used Axiomatic Design to model the current system because of the ease of targeting areas for improvement in a solution neutral environment.

6.3 Developing Solutions for WWC1

The team developed solutions for WWC1 by identifying waste, designing and developing a new tool for the workstation, and decoupling unnecessary process steps and redefining standardized work.

6.3.1 Identifying and Reducing Waste

A 5S event has already be implemented at WWC1, and the strategies are still being applied to the workstation. To evaluate the success of the implemented event, the team created a 5S Audit Sheet (Appendix C). After analyzing the audit sheet, the team observed that 5S strategies are continuing to be implemented at WWC1. However, the continuity of this implementation is key for a standard work. To create this standard work, the team identified some wastes at the workstation which prevented having a standard work. Transportation, inventory, motion, and defects are the wastes found at WWC1. It is critical to reduce these wastes in order to decrease the cycle time and increase the efficiency at the workstation.

Transportation was identified as a waste at WWC1 because of the time it takes to transport the next job to and from the workstation. WWC1 has a two bin system implemented where the job currently being worked on is stored in the top bin, while the next job is queued underneath. Though this system is implemented at the workstation, it is not being used to its full potential, and the operator is often spending 7 minutes (2.29% of the process time) transporting parts. The transportation pattern for WWC1 is illustrated in Figure 4. Because of the size and

weight of the pinion jobs, the operator must use a pallet jack to transport jobs. Locating and returning the pallet jack was also identified as a transport waste. Any time the operator needed to move the pinion, a crane was used to transport the part. The team worked to reduce the necessity for the crane in the standardized work in an effort to diminish transportation waste created by walking back and forth to the crane queuing station.

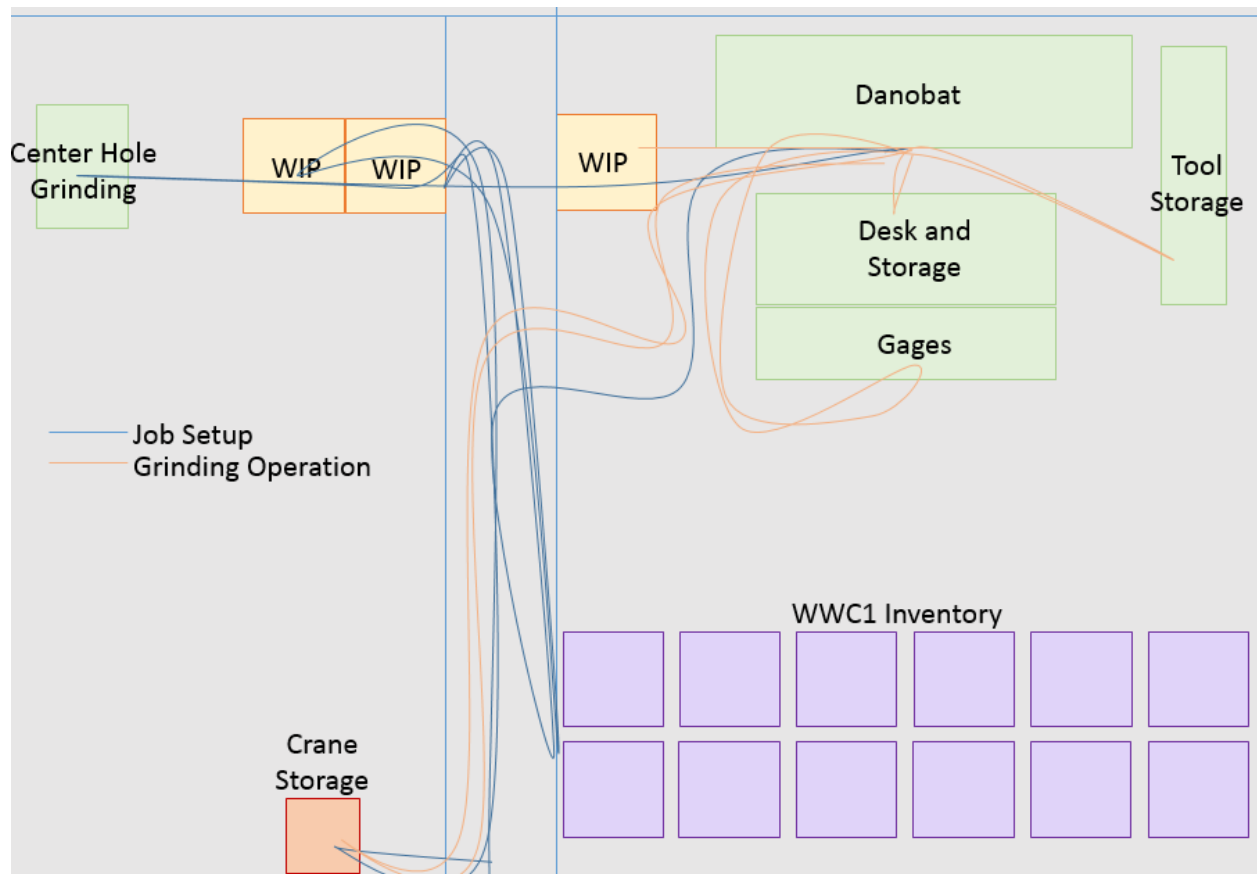

Figure 4: Spaghetti Diagram of Current Transportation Pattern for WWC1

The second waste identified in the workstation was inventory. The current process for finding the next job to be worked on at WWC1 is pictured in Figure 6.4 below. Before the pinion reaches WWC1 for grinding operations, it leaves the facility for a plating procedure. Once the plating procedure has been completed, the jobs are stored in an inventory warehouse across the Primetals lot until it is transported back into the facility for grinding operations on WWC1. The off-site inventory warehouse makes a daily delivery of pinion jobs to the WWC1 workstation, pictured in Figure 6.4 below. The inventory for every machining cell in Bay 8 is allocated to be stored in this area. However, the jobs queueing for WWC1 are overflowing into the inventory

storage for other workstations. 846 square feet of floor space in Bay 8 is dedicated to inventory for the machining cells. Of that 846 square feet, 162 square feet is assigned to WWC1, however 306 square feet is actually being used for WWC1 inventory. The inventory warehouse has enough excess storage space for the pinion jobs returning from the plating procedure. Therefore the excess inventory located in the Bay 8 queuing system was identified as a waste in the floor space. Not only do the queued jobs take up space that could be assigned to value-added activities, such as adding another machining cell, but they also create a waste of time because the operator must search through every job before they find the job they are looking for. Searching through jobs with the pallet jack and reordering them takes the operator an average of 28 minutes per job (or 7 minutes per pinion).

Step 1: Trying to find the correct part number on the documents.



Step 2: Removing all the pinions in the front to find the next job.

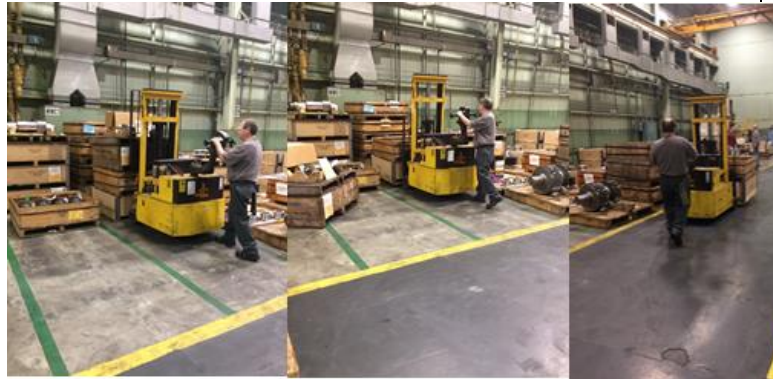

Step 3: Looking for the documents again to find the next job.



Step 4: Filling out the empty bins in both stations one by one.

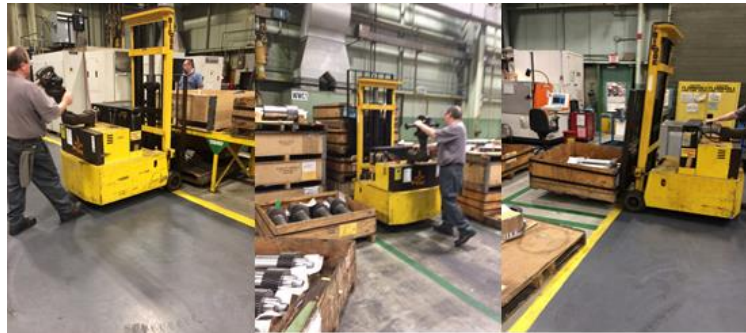

Step 5: Putting the other pinion jobs back into inventory

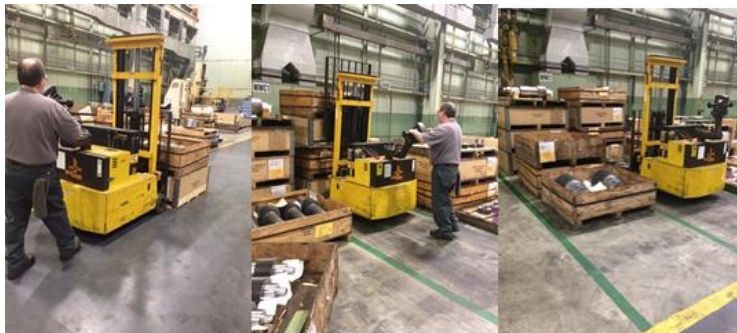

Figure 5: Current Process for Finding a Job in Bay 8 Inventory Management System

Motion was another waste identified in the Danobat job setup. When setting up a new pinion job, the operator needs to remove and replace the chuck jaw inside the Danobat. In order to remove the chuck jaw, the operator must access the inside of the machine through a panel in the side. Because the operator is working inside the machine, a lightweight portable light with an

extension cord is used to perform the removal (Figure 6). To retrieve the light, the operator untangles the extension cord, sets up the light inside the machine, and puts away the extension cord and light. This process takes an average of 10 minutes per job. This is non-value added time that contributes to 3.27% of the pinions processing time at WWC1.



Figure 6: Portable Light used in Chuck Jaw Removal

As mentioned before, overhead cranes are used to transport heavy parts in Bay 8. The chuck jaw is far too heavy to be lifted by the operator safely without a crane. Currently the operator must remove the chuck jaw from the Danobat using a crane, placed on a nearby desk. After the chuck jaw is placed on the desk by the crane, it is then carried, by the operator manually to the storage box, located just out of reach of the crane (Figures 7 and 8). This not only poses a potential safety risk to the operator and to the machine itself, but it also creates an unnecessary waste of motion because of the change from crane motion to manual motion. The removal takes approximately 8 minutes (3.27% of the total process time).



Figure 7: Chuck Jaw Storage

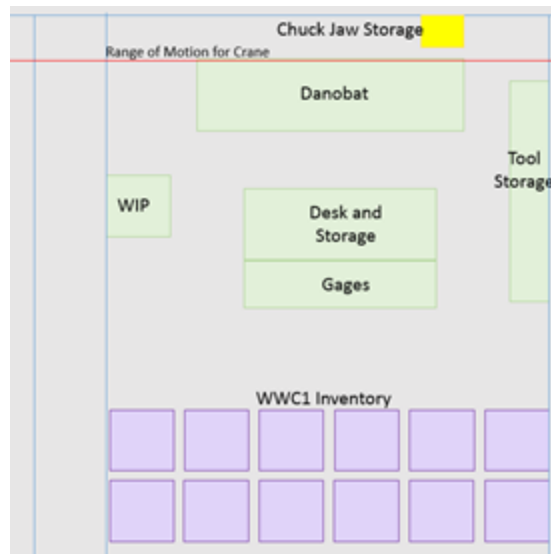

Figure 8: Chuck Jaw Storage in Workstation Layout

The last waste identified at WWC1 was due to defects in the pinion process. The team observed that the potential for defects in the pinion process was extremely high because the operators need to convert the measurements on the part blueprints from metric to standard in order to perform the Danobat operations. Many of the pinions are products for overseas customers, which is why engineering designs in metric units. However the Danobat is an American made machine, based on English units, therefore the inputs needed for the operations to be performed accurately need to be inputted in standard units. This is a tedious and potentially risky way of operating because the operators must manually convert the measurements from

metric to standard for the machine inputs and then back from standard to metric for the self-inspection tracking sheet. Though the operator is trained to quickly make these conversions, the risk for human error is high. The operator also spends an average of 5 minutes per pinion (1.63% of total cycle time) making conversions.

The wastes found at WWC1 can be summarized in Tables 1 and 2. These wastes take up a total of 19.93% of the total cycle time and 39% of setup time. Reducing these wastes had a huge impact on the pinion process at WWC1.

Waste	Original Time (minutes)	% of Total Cycle Time
Measurements not standardized	5	1.63%
Queuing jobs	7	2.29%
Center hole operation	21	6.86%
Light installation	10	3.27%
Chuck jaw removal	8	2.61%
Gage construction	10	3.27%
Total Impact	61	19.93%

Table 1: Identified Wastes from Manufacturing in System

Waste	Original Time (minutes)	% of Total Cycle Time
Defect Waste	5	1.63%
Inventory Waste	7	2.29%
Transportation Waste	21	6.86%
Movement Waste	28	9.15%

Table 2: Summary of Identified Waste by Type of Waste in System

6.3.2 Opportunity for Standardization of Tools in the Work Space

WWC1 houses over twenty different sized gages. The inspection gages that are used to measure the outer diameter (OD) grind of the pinions are crucial to the quality control of the operation. However, the team observed that operators needed to create their own measuring devices with block gages in order to conduct the self-inspection step required for the operations conducted on WWC1 (Operator 1, 2016). The need for creating these gages from scratch stems from the fact that other operators in Bay 8 are taking tools from WWC1 to their own workstation and not returning them. Assembling a gage from scratch when the tool should be readily available at the workstation adds unneeded time to the pinion making process.

A tool check-out system was implemented by Primetals in an effort to track the tools being taken by machinists outside WWC1. This system is composed of a tracking sheet (Figure 9), designed to be filled out by the operator taking the tool and left in a folder for the WWC1 operators and/or management to use when they needed to track a tool. However, this proved unsuccessful because the operators failed to take the time to fill out the tool tracking form. There was no accountability held by management for the operators to fill out the form, so the implementation of the tool check-out system failed (Colby, 2016).

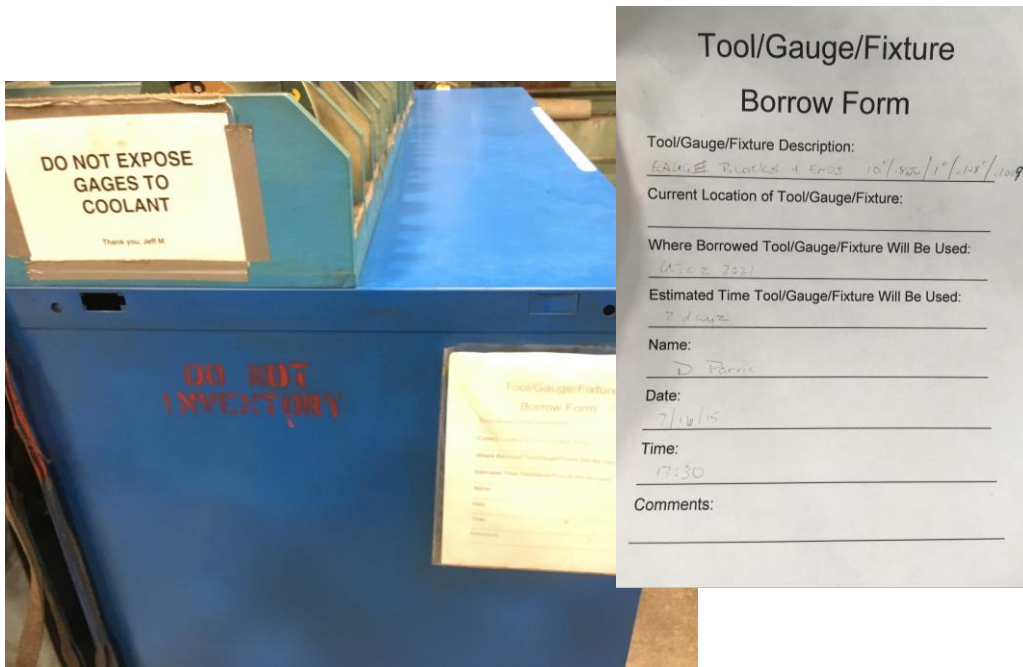

Figure 9: Gage Inventory Management System at WWC1

The Primetals MQP team saw this as an opportunity for tool design due to the failed implementation of an inventory management system. The mechanical engineer in the team took the lead on this design because of the background required in manufacturing design. Consultations with machinists, operators, and inspection technicians were conducted in order to understand the design requirements needed to design a universal tool for gaging the pinions. The mechanical engineer then met with the WPI Higgins Machine Shop to refine the design.

6.3.3 Decoupling the Process Steps

The conclusion drawn from the Axiomatic Design decomposition was to attempt to decouple the sequential dependence between the center hole grinding machine and the Danobat outer diameter grinding machine. By taking advantage of underutilized machinists in the WWC1 bay at the center grinding machine-- accomplishing the center grinding tasks—Primetals is able to increase overall bay efficiency and decrease the number of tasks required by Danobat outer diameter grinding machinists. This, in turn, means that Danobat machinists can focus on grinding only outer diameters on pinions, and have subsequently a faster turnaround time for pinions from the WWC1 workstation. A proposed modification of standard work, in line with

this decoupling solution, can be found in Appendix 11.3. As this project’s scope is focused on decreasing the total setup and cycle time in the WWC1 workstation, this decoupling accomplishes that goal.

6.4. Strategy for Implementing Solutions at WWC1

Before implementing the solutions at WWC1 the team pitched the solutions to the operators in an effort to gauge their receptiveness to change. It was important that the operators understood why and how the solutions would be implemented in order for the implementation to be sustainable.

The team also discussed the solutions at length with the lean process manager, Alberto Ortega, to gauge management’s receptiveness to the changes they were making. Alberto assisted in the technical application of the solutions being proposed. He also facilitated any purchasing of materials needed for the solutions as well as acquiring documents needed to facilitate analysis.

6.5. Financial Analysis Methods

Financial analysis is a critical aspect to determining the success of a project in addition to addressing project goals set by the sponsor. To analyze the project, we used a cash flow diagram, as well as the formulas shown in Equation 1 to calculate the potential increase in revenue per quarter as a result of implementing the solutions, given that demand will absorb any increases in production.

$$\text{Increase in production} = \frac{\text{Current production}}{100\% - \text{Reduction in cycle time}} - \text{Current production} \quad (1)$$

$$\begin{aligned} & \text{Potential increase in sales revenue} \\ & = \text{Increase in production} \times \text{sales revenue per pinion} \quad (2) \end{aligned}$$

Equation 1: Formulas to Calculate Quarterly Cash Flow Increases

As there is minimal financial investment for our solutions, the up-front investments for the proposed solutions were not included. Additionally, the cash flow diagram assumes that there

is no maintenance cost associated with at least the first two years of the project, and the potential earnings generated by freed capacity at WWC1 remains constant over the course of two years. The team estimated a constant demand of 600 pinions per year with pinion sales revenue of approximately \$10,000 per pinion, from information provided by Primetals (Ortega, 2016).

7. Results

The Primetals team implemented and analyzed the impact of the solutions they designed.

7.1 Process Analysis and Implementation of Solutions

After identifying the wastes present at WWC1, the team worked to develop solutions to reduce, and in some cases eliminate, the wastes. The solutions were developed through interviews with operators, system observations, tool design and development, and industry research.

The team eliminated 21 minutes of waste per pinion caused from transportation by decoupling the job queuing task and assigning it to the Bay 8 floater. By decoupling these tasks from the WWC1 standard work, the total cycle time for a pinion at this workstation was reduced by 6.86%. The new pattern for transportation is compared with the original transportation pattern in Figures 10 and 11 below.

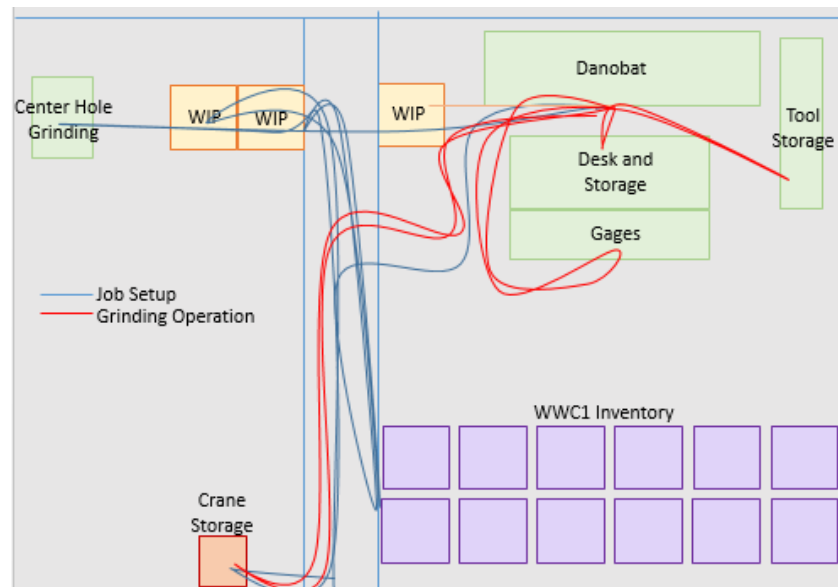

Figure 10: Old Transportation for WWC1

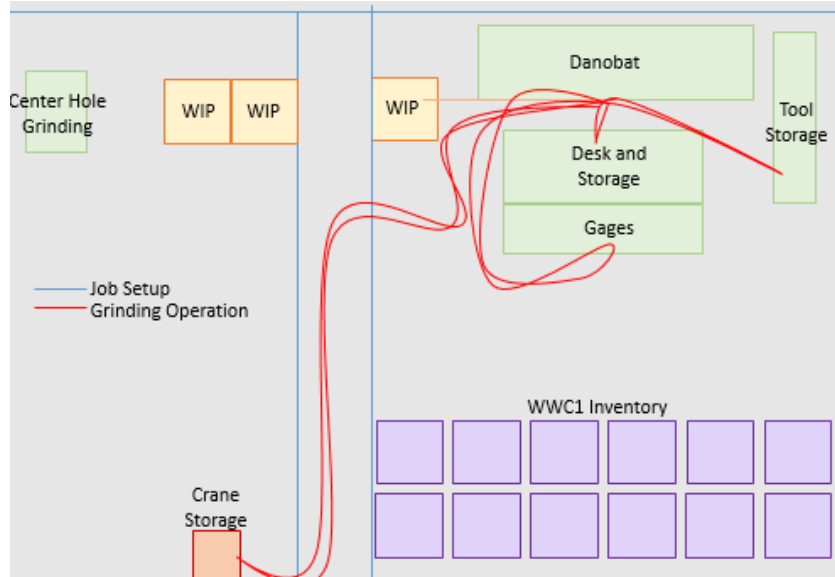

Figure 11: New Transportation for WWC1

By redefining the standard work for the inventory management system for Bay 8, the team eliminated 7 minutes per pinion (2.29%) from the total cycle time. The warehouse will use a visual queuing system to ensure that there are only 5 jobs (or 5 pallets) in inventory at a time. The new inventory management system can be seen in Figures 12 and 13 below. Because of the frequency of deliveries to Bay 8, the warehouse delivery personnel can easily replenish jobs before WWC1 runs out. With the new inventory management system in place the operator no longer needs to search through dozens of jobs to find the next pinion job. By applying this to the six machining workstations on Bay 8, there will be 654 square feet of floor space freed up to be used towards value added activities at Primetals.

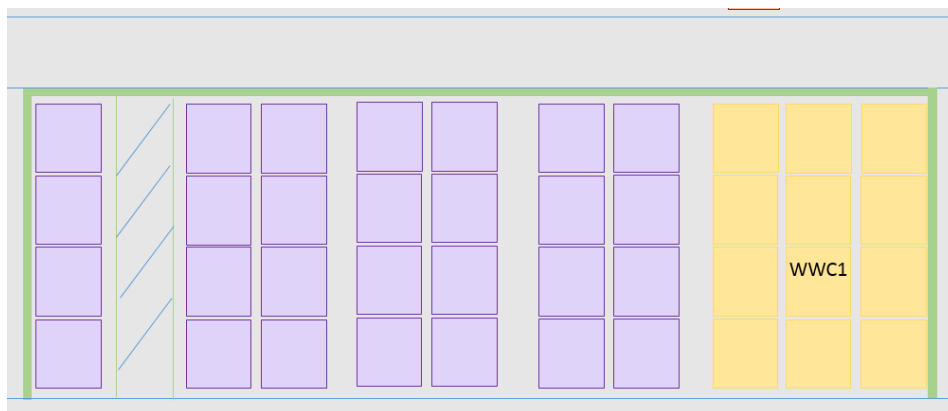

Figure 12: Old Inventory Management System

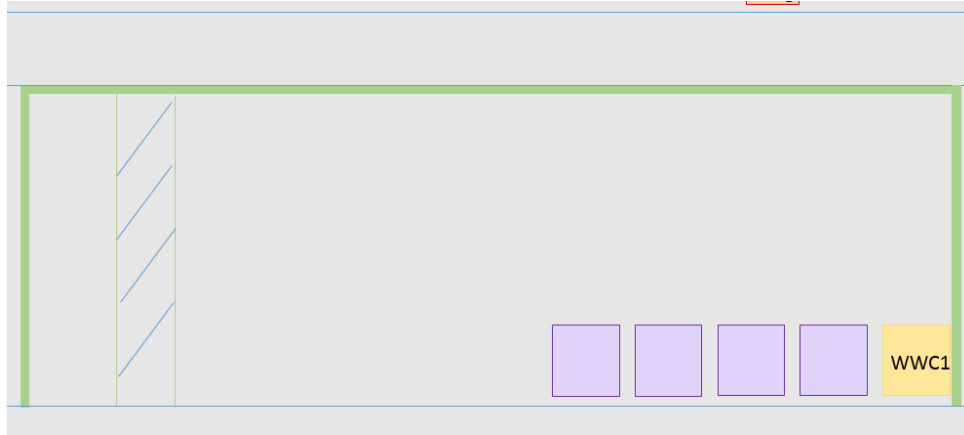

Figure 13: New Inventory Management System

In order to reduce the waste of motion, the team redesigned the lighting used for the removal of the chuck jaw and reassigned the position for the chuck jaw storage on the Danobat. The team researched many different lighting options to find a light that would work in the machine and eliminate the time wasted in installing the portable light currently being used while allowing the operator to safely perform the chuck jaw removal. The light chosen is pictured below in Figure 14.



Figure 14: Chosen Light for Danobat: Grainger Model 5RHN0 (Grainger, 2017)

The team chose this light because of its ability to be easily removed and placed into the Danobat and because it is battery powered which would eliminate the time wasted by coiling and uncoiling the extension cord. The team also evaluated the structure of the current WWC1 layout and determined where the chuck jaw storage box would best fit while staying within the reach of the crane to ensure safety requirements are met. The new and old locations are compared in

Figure 15. The operators were supportive of this change as it provides less physical strain on their part as well as reducing the transportation waste currently in the process.

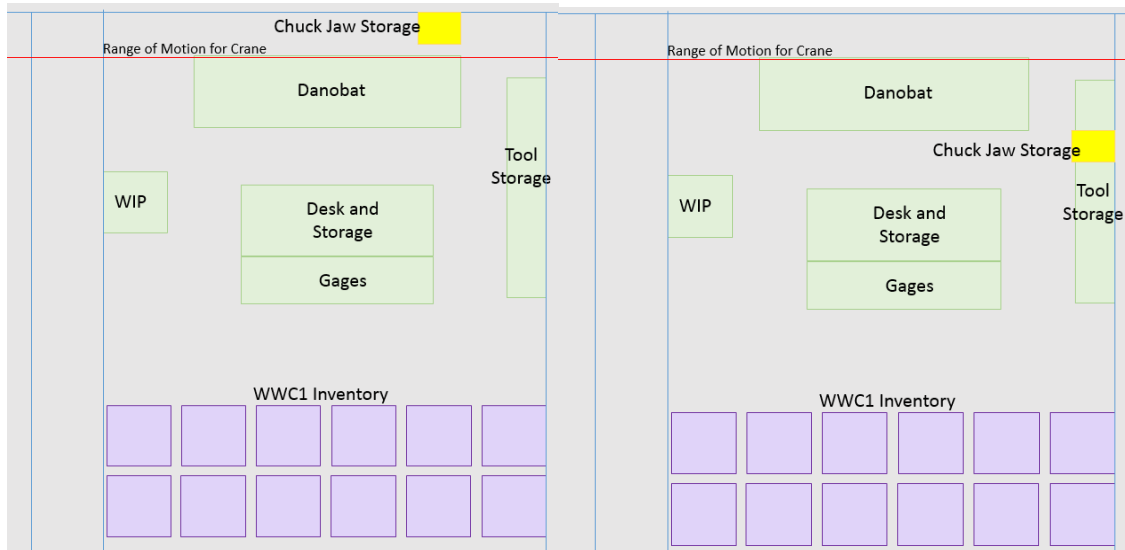

Figure 15: Before and After Chuck Jaw Location

The motion caused from assembling gages took the operators approximately 10 minutes per pinion. Between gathering the parts needed for assembly, assembling the gage, and testing for accuracy, the non-value added time was building up. By designing the universal gage (further discussed in Section 7.2) the operators save an average of 9 minutes per pinion (2.94% of total cycle time).

The team worked with engineering to standardize the units on the pinion blueprints. The program used in engineering to design the pinions has an option to display all units in standard or in metric. Engineering now prints the blueprints and inspection tracking sheets with this setting, so the operator no longer needs to convert units at the source. Because the metric units are still displayed on the inspection tracking sheet, the customer can easily review the product they received meets the specifications in which they requested. This eliminates the risk in converting units back and forth by hand as well as eliminating an average of 5 minutes per pinion (1.63%) from the processing time.

Implementing the solutions at WWC1 eliminated 51 minutes of waste (16% of total cycle time) from the pinion processing time at this station (Tables 3 and 4).

Waste	Original Time (minutes)	Time Saved (minutes)	% of Total Cycle Time	% Reduction from total Cycle Time
Measurements not standard	5	5	1.63%	1.63%
Queuing jobs	7	7	2.29%	2.29%
Center hole operation	21	21	6.86%	6.86%
Light installation	10	7	3.27%	2.29%
Chuck jaw removal	8	2	2.61%	0.65%
Gage construction	10	9	3.27%	2.94%
Total Impact	61	51	19.93%	16.67%

Table 3: Summary of Changes and Solution Impact

Waste	Original Time (minutes)	Time Saved (minutes)	% of Total Cycle Time	% Reduction from total Cycle Time
Defect Waste	5	5	1.63%	1.63%
Inventory Waste	7	7	2.29%	2.29%
Transportation Waste	21	21	6.86%	6.86%
Movement Waste	28	18	9.15%	5.88%

Table 4: Summary of Changes and Solution Impact by Waste

The total cycle time for pinion processing at WWC1 was reduced from 5.1 hours to 4.3

hours once the solutions were implemented. Figure 16 breaks the total cycle time down to three main steps: setup before the pinion reaches the Danobat, setup on the Danobat, and operations on the Danobat machine. Each step is represented in a different color to show the impact the changes made on each step of the process, as well as the total cycle time as a whole.

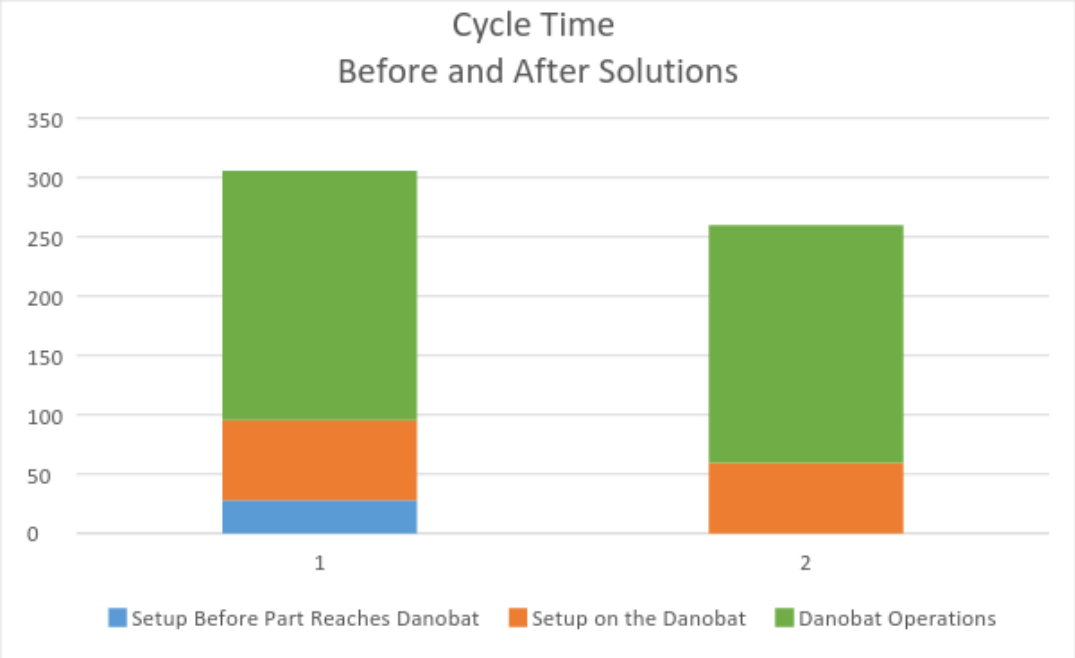

Figure 16: Impact on WWC1 Pinion Cycle Time Before and After Solutions

The Primetals team succeeded in reducing setup time by 39% once solutions were implemented. The time was reduced from 1.58 hours to 59 minutes by the implementation of solutions. Figure 17 breaks down the setup time by setup before the pinion reaches the Danobat and setup on the Danobat.

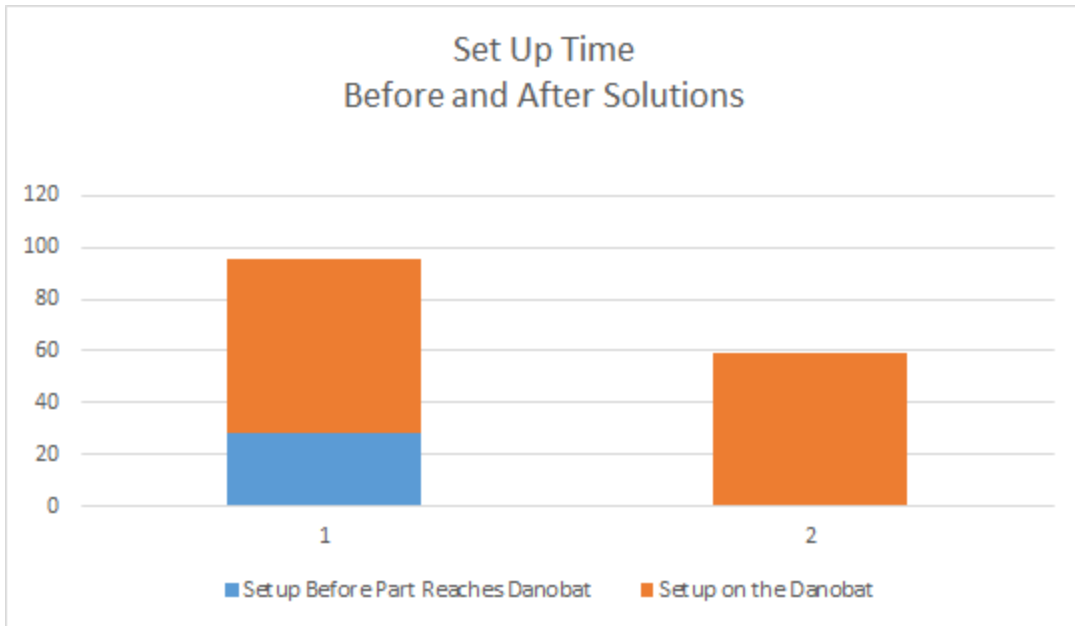

Figure 17: Impact on WWC1 Pinion Setup Time Before and After Solutions

7.2 Variable Adjustment Inspection Gage

The Primetals MQP team utilized the WPI Washburn Machine Shops to design and produce a variable adjustment inspection gage for operator use at the Primetals facility. The team’s mechanical engineer performed the designing, manufacturing, and assembly of the gage. In collaboration with the WWC1 operators and Primetals’ head inspection technician, the functional requirements needed for the gage were noted. When reviewing the requirements, the primary focus was on adjustability, functionality, and ergonomic requirements needed to create a smart, simplistic design. Attention was also paid to the tight tolerances (± 0.001 ”) required for Primetals to assure a quality pinion. Figure 18 shows the notes taken in accordance with observation and interviews.

Design Notes	
<ul style="list-style-type: none"> Notes from Operator: <ul style="list-style-type: none"> • Must be able to navigate around pinions in WWC1 machines: 2 inch clearance • Needs : Indicator, preload-up to 7000 psi, 30,000 travel • Non-sticky substance for measurement tip • Must have tolerance of within .001 inches 	
<ul style="list-style-type: none"> Design Changes: <ul style="list-style-type: none"> • Will create notched rod instead of threaded • Will place up within gage to shorten device • Will put slide attached to bottom for fine measurement • Handle will be sliding rod to lower complexity • Still need locking mechanism for both notched rod and slider • Overall length while extended: 14.75 inches • Overall length while closed: 9.75 inches • Overall Width: 1.2 inches excluding slider (1.4 inches) • Notched rod: notches every .075 inches • Gear: 20 teeth spaced 18 degrees apart • Materials: Steel or Aluminum 	

Figure 18: Gage Design Notes

With a full understanding of the functional requirements, the SolidWorks design of the Variable Adjustment Inspection Gage was created (Figure 19). With SolidWorks simulation feature, shear forces and stress tests were conducted to determine if the gage would be able to withstand the abuses of daily use. After the design phase was complete, the design was brought to the WPI Higgins Machine Shop for critiques and to conclude whether the SolidWorks design would be reasonably manufacturable. The initial SolidWorks design was deemed infeasible within the time span required for the project, so, with aid from the WPI Higgins Machine Shop Staff, a new, practical redesign of the variable adjustment gage was created (pictured in Figure

20). Once the redesign of the gage was finished, manufacturing and assembly of the gage prototype could begin.

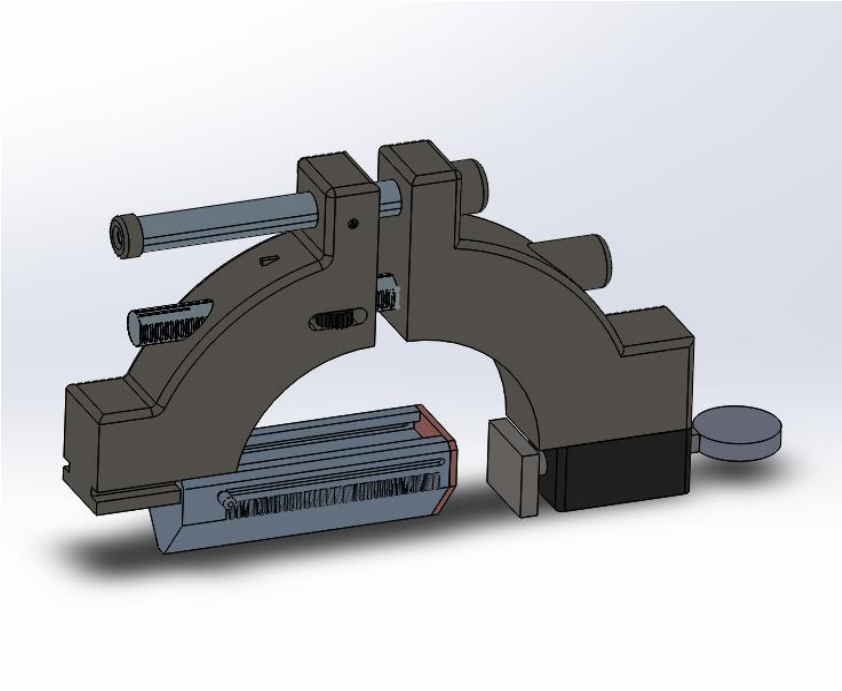

Figure 19: AutoCAD Rendering of Universal Gage

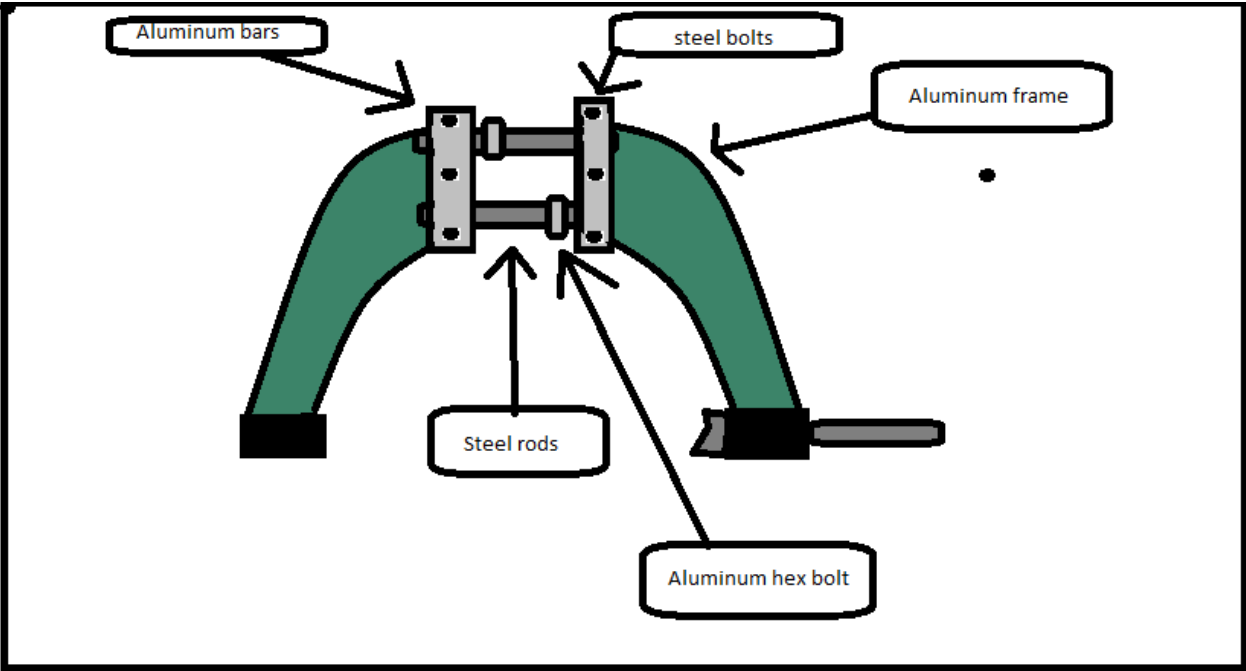

Figure 20: Gage Prototype Design

To manufacture the gage the mechanical engineer, with the help of Primetals, purchased a number of parts. These parts included: an old aluminum snap gage, two 3"x 1"x 1/2" aluminum bars, two 6" long 3/4" thick threaded steel rods, and six 1/4", 3" long steel hex nut screws, and one Pittsburgh 1" Travel Dial Indicator. All manufacturing took place within the WPI Washburn Machine Shops. When manufacturing the device, the mechanical engineer first used a band saw to cut the old snap gage (Figure 21) into three individual pieces; the two curved sides of the gage, and the remaining handle in the middle. Next, using a drill press, three 3/4" holes located 1/4" from the side and 1.3" apart were drilled and centered into each individual curved piece. Still using the drill press, three 1/4" holes, 1.3" apart, 1/4" into the 1/2" side were drilled into both aluminum bars. Then, adjusting the drill bit size on the drill press to 3/4", two 3/4" holes were drilled, 2" apart and 1" from the side of both aluminum bars. Once all the holes for the device were drilled, the holes were tapped for threaded fasteners.



Figure 21: Old Snap Gage

The final stage of creating this gage was the assembly. First, each 3/4" steel rod was screwed into the 3/4" holes on the aluminum bars. A nut was then placed onto each rod, a crucial step, as it allows for the fine adjustments needed for the gage. Next, the remaining aluminum bar was pressed onto the opposite side of the rods, forming the attachment that provides adjustment for the gage. Then the three holes on one of the aluminum bars were aligned with the three holes

on one of the curved pieces of gage. A steel hex screw was placed within each of the holes and secured each with a nut. This process was repeated for the remaining pieces of aluminum bar and gage. This allowed for the adjustment attachment to be connected to the gage frame. The functionality was later tested on a pinion produced by Primetals. All pictures of the manufacturing process are located in Appendix C.

7.3 Financial Analysis

In analyzing the project's financial impact for Primetals, the improvement in throughput, reallocation of floor space, and gage's impact were evaluated. The team was able to fully eliminate the setup time from cycle time entirely by implementing several solutions including decoupling sequential dependence between center grinding and OD grinding and using a two-bin system at both the Danobat and center grinding machines.

As the team observed through this project, Primetals currently struggles to keep up to their production schedule at WWC1 and is unable to complete many of their orders. The impact of the team's solutions allows Primetals to improve their throughput from 600 pinions to 720 pinions. The financial investment of these improvements are almost entirely negligible, since all but one solution utilize resources readily available at Primetals. The two solutions that required purchases were the light that was installed in the Danobat to assist with chuck jaw adjustments, at a cost of \$81; and the universal gage which cost \$550 for parts and manufacturing. An improvement on the prototype gage created for the project would involve another investment of \$400 for a more precise Starrett dial indicator. The cost breakdown of the solutions appears in Table 5.

Item		Total Price
Gage	Aluminum Bar	\$32.00
	Carbon Steel Threaded Rod	\$66.00
	Steel Threaded Stud	\$12.00
	Black-Oxide Alloy Steel	\$12.00
	Pittsburgh Dial Indicator	\$18.00
	Labor	\$0.00
	Starrett Dial Indicator	\$400.00
	Steel Hex Nut	\$10.00
Total Gage Cost:		\$550.00
Light		\$81.00
Total Cost:		\$631.00

Table 5: Solution Cost Breakdown

The average revenue Primetals receives from each completed pinion is approximately \$10,000. With the improvements provided by the team, the potential increase in pinion production capacity is equal to 120 pinions. If Primetals customer orders absorbed the additional capacity for production, the company could experience an increase of sales revenue of approximately \$300,000 quarterly. The formulas used to calculate the values in Table 6 are seen in Equation 1.

Current production	600	Pinions per year
Reduction in cycle time	16.67	Percent
Increase in production	120	Pinions per year
Revenue	10,000	Dollars per pinion
Increase in revenue	300,000	Dollars per quarter

Table 6: Calculations for Financial Analysis under Fully Loaded Conditions

The impact of these changes can be seen in Figure 22.

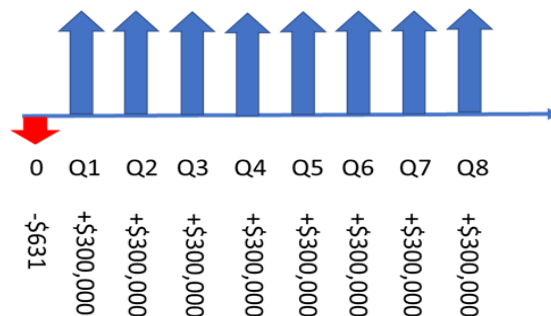

Figure 22: Financial Impact of Solutions

Freed capacity from the implemented solutions allows Primetals to produce 30 more pinions per quarter. This equates to 120 additional pinions per year, and 240 additional pinions over the course of two years following implementation, assuming that the solutions the team put in place are sustained. If Primetals were to sell all of the extra pinions manufactured with freed capacity these solutions would have created, the two year estimated earning potential due to the team's implemented improvements is \$2,400,000.

The universal gage also has an impact on the observable cycle time and productivity of the machine operators, since prior standard work had operators searching for the correct gage and building a new gage if the proper one is missing. The universal Variable Adjustment Gage gives operators a better solution, improves morale and, in turn, increases productivity. The solutions have increased throughput and reduced waste in the production process.

8. Discussion

As requested by Primetals, the two main goals for this project were:

- Reduce the cycle time by 20%, with an actual outcome of 16%;
- Reduce the setup time by 20%, with an actual outcome of 37%.

Although the 20% reduction in cycle time was not reached, the second goal of reducing setup time far exceeded the goal. The cycle time was also much higher than originally calculated by Primetals, as the initial time study conducted by MassMEP in July did not include machine breakdowns. Thus, the 16% cycle time reduction resulted in an overall cycle time reduction greater than the time value associated with a requested 20% reduction of the original MassMEP cycle time. There were also a series of problems encountered over the course of the project.

8.1 Challenges Encountered

Primetals management and machine operators were both supportive of the project and encouraging of open communications. Due to this, the team frequently visited the project site to interview various employees and gather data through observation. However, there were several setbacks throughout the initial research stage of the project, including unexpected changes in the workstation, machine maintenance down time, and miscommunication within the company.

The first obstacle encountered was the Danobat, the primary machine observed in the WWC1 workstation. The Danobat was down for repairs for the first several months of the project. Once the Danobat was operational again, another issue arose while the team attempted to record time studies: there were several operators of the machine, and each had a unique process for machining pinions. This led to high levels of variability in the times recorded. A new hire being trained on the Danobat halfway through the team's data collection phase led to increased time spent accomplishing each task, creating a trend. There was also an issue of recording a full pinion's manufacturing due to the variability in how long each pinion takes to make and the limited availability of the team to go to the site for time studies.

Another source of setbacks during this project was miscommunication between the team and the different management employees at Primetals. One Primetals contact for the project had encouraged the team to pursue 5S solutions for the project and that they should complete a 5S

audit for the workstation's status. However, after the audit was completed, another management contact informed the team that 5S had already been implemented into the workstation and that waste reduction solutions should be researched and implemented instead of 5S. This shows there are some communication challenges throughout management of Primetals. This also caused the team to have to reevaluate their plan of action, and if the team had been made aware of this new focus, the team would have had more time to identify and resolve even more issues with the current process.

Despite the challenges, the team was able to create low cost solutions that increased productivity and saved floor space in Primetals.

8.2 Tolerance Analysis of Variable Adjustment Gage

To test the validity of the Variable Adjustment Gage, a tolerance stack-up analysis was performed, as this would determine the accuracy and precision of the gage by examining the tolerance stack-up of both the gage and pinion. Data collected on the outer diameter variances on the pinion from grinding and gage inspection was analyzed to determine the degree to which the gage would be suitable for use in the shop at Primetals.

Pinions are manufactured to exacting standards, according to an assortment of functional requirements and customer needs communicated through the part drawing. Every new job that arrives at the WWC1 workstation may not have the same size pinions as the previous job. Additionally, there may be multiple critical outer diameter dimensions on a single pinion. These requirements demonstrate the need for WWC1 operators to measure a variable range of feasible outer diameters during the manufacturing process. The pinions produced by Primetals also need to be highly uniform in meeting the specifications—in other words, they need to satisfy tight tolerances—in order to meet the customer requirements. To meet these requirements in an expeditious manner, machine operators utilize snap gages and master pinions. The snap gages used by Primetals are made by Federal and come with a dial indicator which exhibits a precision of up to one ten thousandth of an inch (Moisan, 2017). The master pinions used by Primetals have a dimension tolerance of up to two ten thousandths of an inch (Moisan, 2017). The Variable Adjustment Gage, designed for this MQP to be readily adjustable for changes in outer diameter

size (thus eliminating the requirement for WWC1 operators to build their own gages), will be tested against these requirements.

To effectively evaluate the accuracy and precision of the Variable Adjustment Gage, the MQP team went to the Primetals facility and tested the gage on a manufactured pinion. Figure 23 shows the drawing of the measured test pinion. Figure 24 depicts the dimensions which were later measured to test the Variable Adjustment Gage.

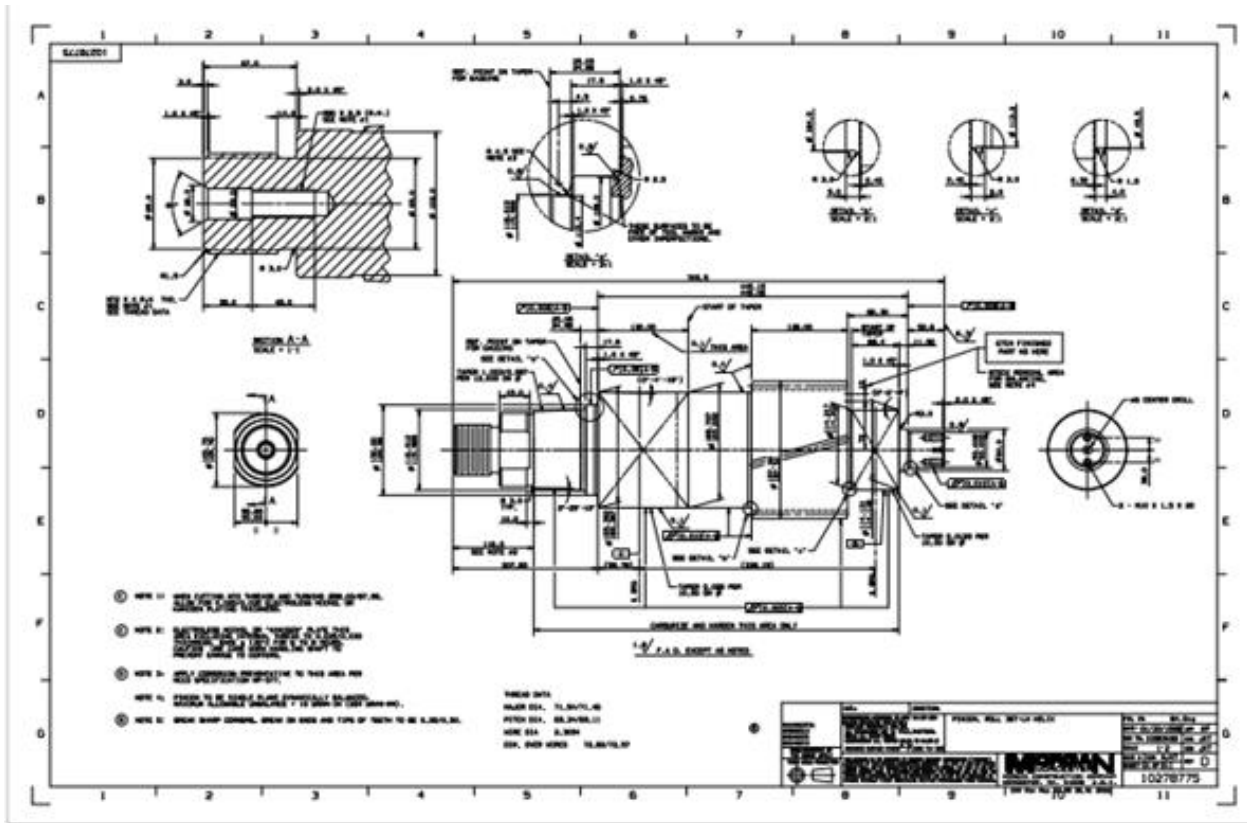

Figure 23: Pinion Drawing

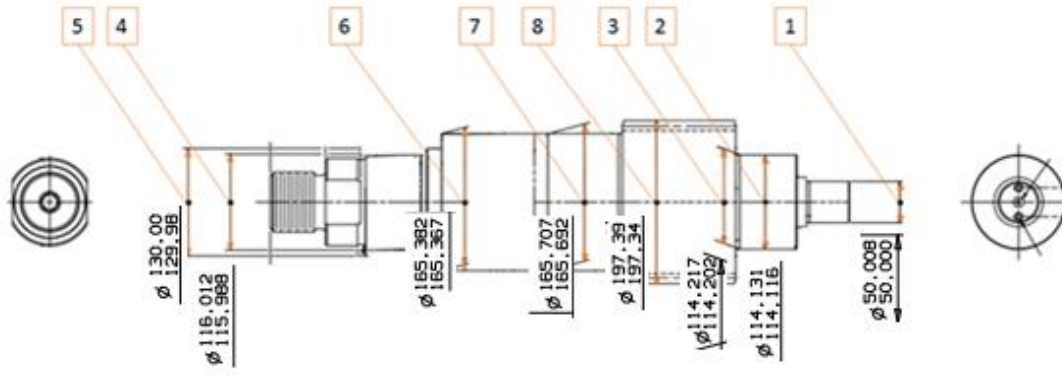

Figure 24: Outer Diameter Dimension Label Reference Diagram

The drawing shows the required dimensions with allowable tolerances. The test measured pinion shown in Figure 23 met all the stated dimensions for customer requirements, a fact confirmed by the WWC1 machine operator with a set of Federal snap gages. To determine if the Variable Adjustment Gage could measure these dimensions with sufficient accuracy, the MQP team measured each diameter ten times. This was to make sure the prototype gage worked properly, in addition to gathering a wide array of data. The data collected from the tests sets is shown in Table 7 and Table 8. All data collected was recorded in metric units, specifically millimeters (mm). Table 7 is a collection of the required dimensions (mm), plus the allowable tolerances above and below the required dimensions from the above pinion drawing. The tolerance exceeding the upper bounded dimensions were called positive tolerances. The allowed tolerances less than the required dimensions were labelled as negative tolerances. The first column of the table lists values given to the dimensions to log their respective (ascending) order from the drawing. Table 8 compares the tolerances measured by the Variable Adjustment Gage with the required dimensions for the pinion. This table also lists averages of the measurements from the gage which are above the required dimension and averages of the measurements from the gage which are below the required dimension. Table 8 also maintains the same value system assigned to Table 7 to represent the order of dimensions on the drawing.

Pinion Dimensions	Tolerances of Primetals Pinions (mm)					
	Required		Negative		Positive	
	Dimensions (mm)	(in)	Tolerance (mm)	(in)	Tolerance(mm)	(in)
Dimension 1	50.0040	1.9687	50.0000	1.9685	50.0080	1.9688
Dimension 2	114.1235	4.4931	114.1160	4.4928	114.1310	4.4933
Dimension 3	114.2095	4.4964	114.2020	4.4961	114.2170	4.4967
Dimension 4	116.0000	4.5669	115.9880	4.5665	116.0120	4.5674
Dimension 5	129.9900	5.1177	129.9800	5.1173	130.0000	5.1181
Dimension 6	165.3745	6.5108	165.3670	6.5105	165.3820	6.5111
Dimension 7	165.6995	6.5236	165.6920	6.5233	165.7070	6.5239
Dimension 8	197.3650	7.7703	197.3400	7.7693	197.3900	7.7713

Table 7: Required Pinion Tolerances

Pinion Dimensions	Required		Positive Gage		Negative Gage	
	Dimensions (mm)	(in)	Measurements (mm)	(in)	Measurements (mm)	(in)
Dimension 1	50.0040	1.9687	50.1350	1.9735	49.8729	1.9635
Dimension 2	114.1235	4.4931	114.2851	4.4984	113.9891	4.4878
Dimension 3	114.2095	4.4964	114.3439	4.5017	114.0750	4.4911
Dimension 4	116.0000	4.5669	116.1390	4.5674	115.8611	4.5615
Dimension 5	129.9900	5.1177	130.1270	5.1231	129.8529	5.1123
Dimension 6	165.3745	6.5108	165.5089	6.5161	165.2400	6.5055
Dimension 7	165.6995	6.5236	165.8341	6.5289	165.5651	6.5183
Dimension 8	197.3650	7.7703	197.5170	7.7763	197.2130	7.7643

Table 8: Measured Dimensions vs. Required Dimensions for Pinions

To determine if the gage was suitable for measuring Primetals pinions, first the difference between the “positive” and “negative” tolerances allowed for the pinion versus the difference of positive and negative tolerances measured by the gage was calculated (Equation 2). This same method was applied to the measurements from the gage to determine deviations in measurements from the gage (Equation 3). The calculated differences were then plotted on a graph to see where allowable tolerances fell in relation to measured gage tolerances. The X axis corresponds to the numerical values assigned to the data, while the Y axis represents the range of variation in millimeters (mm). In order for a gage to be suitable for use in the shop at Primetals, the gage must satisfy Equation 4. Values used for Equation 4 are plotted in Figure 25.

$$X_{1n} - Y_{1n} = Z_{1n} \text{ (Equation 2)}$$

n = numerical value assigned to pinion dimension

X_{1n} = value of positive tolerance

Y_{1n} = value of negative tolerance

Z_{1n} = value of tolerance differential of pinion

Equation 2: Calculation of Tolerance Differential

$$X_{2n} - Y_{2n} = Z_{2n} \text{ (Equation 3)}$$

n = numerical value assigned to pinion dimension

X_{2n} = value of positive gage measurement

Y_{2n} = value of negative gage measurement

Z_{2n} = value of tolerance differential of gage

Equation 3: Calculation of Tolerance Differential

$$Z_{2n} \leq Z_{1n} \text{ (Equation 4)}$$

Z_{2n} = value of tolerance differential of gage

Z_{1n} = value of tolerance differential of pinion

Equation 4: Equation to Determine Gage Use at WWC1

$$Z_{2n}/Z_{1n} \text{ (Equation 5)}$$

Z_{2n} = value of tolerance differential of gage

Z_{1n} = value of tolerance differential of pinion

Equation 5: Calculation of Accuracy for the Starrett Gage

Pinion Dimensions	Tolerance Differential of Allowable vs. Measured (mm)			
	Allowable Tolerance(mm)	(in)	Measured Gage Tolerance (mm)	(in)
Dimension 1	0.0080	0.0003	0.2621	0.0103
Dimension 2	0.0150	0.0006	0.2960	0.0117
Dimension 3	0.0150	0.0006	0.2690	0.0117
Dimension 4	0.0240	0.0009	0.2779	0.0109
Dimension 5	0.0200	0.0008	0.2741	0.0108
Dimension 6	0.0150	0.0006	0.2690	0.0117
Dimension 7	0.0150	0.0006	0.2690	0.0117
Dimension 8	0.0500	0.0020	0.3040	0.0120

Table 9: Tolerance Differential of Pinions vs the Starrett Dial Indicator

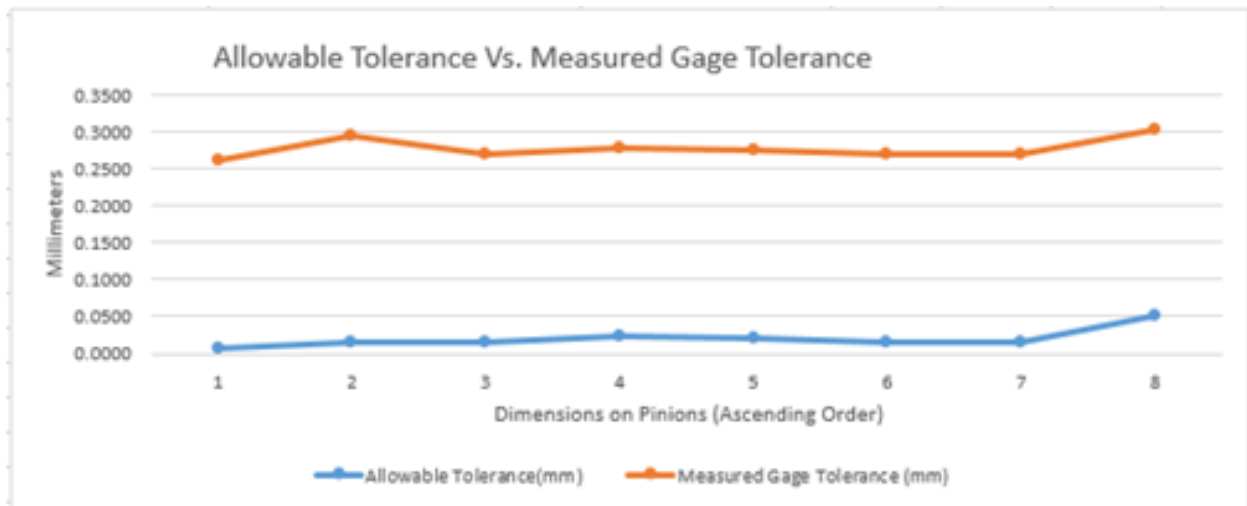

Figure 25: Graph Tolerance Differential of Pinions vs Tolerance Differential of Variable Adjustment Gage Dial Indicator

As seen in the Table 9, the measured tolerances exceed the allowable tolerances for the pinion at every dimension, the largest being 0.08 in deviation. To be an effective measuring device, the gage needs to have a tolerance range which is either smaller or similar in size to the tolerance ranges stated in the pinion drawing. In every instance, the tolerance range of the gage was larger than the respective tolerance range created from the pinion drawings. This determines that the initial prototype Variable Adjustment Gage is not precise enough for required use at the Primetals facility, and the accuracy needs to be improved.

After the initial testing, the MQP team met with the quality assurance manager of Primetals to aid in the examination of the Variable Adjustment Gage and determine why it failed.

Two main reasons contributed to the inaccuracy of the device. The largest factor was the dial indicator on the gage, which could only resolve in thousandths of an inch and had a large tolerance range (± 0.005). The second reason was rooted in the misaligned parallelism, or the unevenness of the gage, providing too much “wobble room,” leading to inaccuracies in outer diameter measurement. The quality assurance manager suggested several adjustments to the gage design which could be made to improve its functionality—to meet and exceed the standards set by Primetals and its customers. The first would improvement is replacing the Pittsburgh 1” (inch) Travel dial indicator with a Starrett 656-617J .400” (inch) dial indicator; the latter resolves precise measurements (ten thousandths of an inch, 0.0001”) required for the quality standards set at Primetals, and is 10 times more precise than the Pittsburgh dial indicator. In addition the Starrett dial variance in measurement is ± 0.0001 ”, a range of variance 50 times smaller than the Pittsburgh Travel dial indicator (Starrett, 2013). Secondly, adding another guide rod to the gage would help aid in rigidity of the device, allowing extremely precise measurements as well as allowing for better sliding motion during adjustment. A third change would be to increase the thread count of the threaded rod for better fine adjustments of the gage. Finally, re-aligning the framing of the gage would eliminate all variability from the gage itself.

The most important design improvement for the prototype gage would be to replace the dial indicator. To evaluate if the Starrett dial indicator would perform adequately, similar calculations as before were made using the technical specifications for the Starrett dial indicator. First, comparisons of the required dimensions for the pinion with the theoretical Starrett dial indicator measurements were calculated (Table 10).

Pinion Dimensions	Measured Dimension vs. Required Dimensions (mm)					
	Required Dimensions (mm)		Positive Starrett Measurements (mm)		Negative Starrett Measurements (mm)	
	(mm)	(in)	(mm)	(in)	(mm)	(in)
Dimension 1	50.0040	1.9687	50.0075	1.9688	50.0024	1.9686
Dimension 2	114.1235	4.4931	114.1272	4.4932	114.1222	4.4930
Dimension 3	114.2095	4.4964	114.2111	4.4965	114.2060	4.4963
Dimension 4	116.0000	4.5669	116.0018	4.5670	115.9967	4.5668
Dimension 5	129.9900	5.1177	129.9921	5.1178	129.9870	5.1176
Dimension 6	165.3745	6.5108	165.3768	6.5109	165.3717	6.5107
Dimension 7	165.6995	6.5236	165.7019	6.5237	165.6969	6.5235
Dimension 8	197.3650	7.7703	197.3681	7.7704	197.3630	7.7702

Table 10: Calculated Tolerances on Starrett Dial Indicator

Next, the tolerance differential of those measurements was determined utilizing the formulas from the original calculations. Subsequently, the Starrett dial indicator tolerance differential was compared to the tolerance differential of the pinion, which can be seen in Table 11. Finally this data was plotted on a graph (Figure 26) to render a visual representation of the precision of the Starrett dial indicator. From the chart, it is obvious that the dial indicator never exceeded the allowable tolerance for a Primetals pinion. The closest point at which the Starrett dial indicator may exceed the allowable tolerance range is at the smallest pinion dimension, with a separation of about 0.0001 of an inch. From this data, the team concluded that the probability of the Starrett rejecting an acceptable pinion or accepting an unacceptable pinion is quite low.

Pinion Dimensions	Tolerance Differential of Allowable vs. Measured (mm)			
	Allowable Tolerance(mm)	(in)	Measured Starrett Tolerance (mm)	(in)
Dimension 1	0.0080	0.0003	0.0051	0.0002
Dimension 2	0.0150	0.0006	0.0050	0.0001
Dimension 3	0.0150	0.0006	0.0051	0.0002
Dimension 4	0.0240	0.0009	0.0051	0.0002
Dimension 5	0.0200	0.0008	0.0051	0.0002
Dimension 6	0.0150	0.0006	0.0051	0.0002
Dimension 7	0.0150	0.0006	0.0050	0.0001
Dimension 8	0.0500	0.0020	0.0051	0.0002

Table 11: Differential Tolerances of Pinion vs. Differential Tolerances of Starrett Dial Indicator

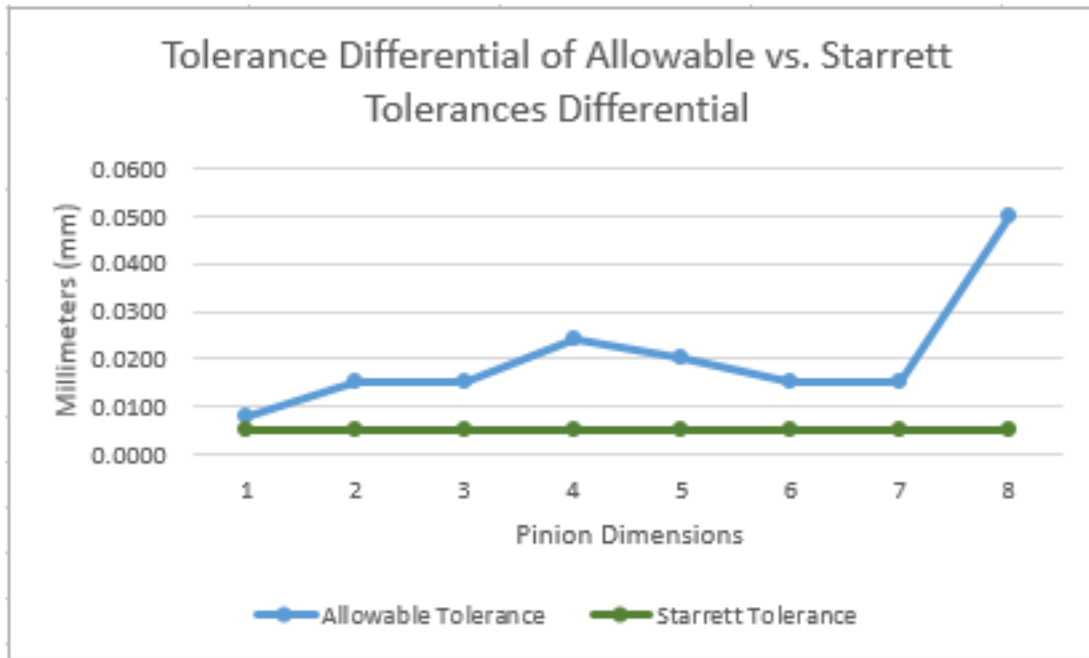

Figure 26: Graph of Differential Tolerance Comparison

To reinforce the precision and accuracy which the Starrett dial indicator has, Figure 27 below outlines the comparison between the tolerance differential for a pinion, the Variable Adjustment Gage dial indicator, and the Starrett dial indicator. The Starrett dial indicator falls well within the tolerance range for the pinion, in addition greatly improving the Variable Adjustment Gage dial indicator in precision and accuracy.

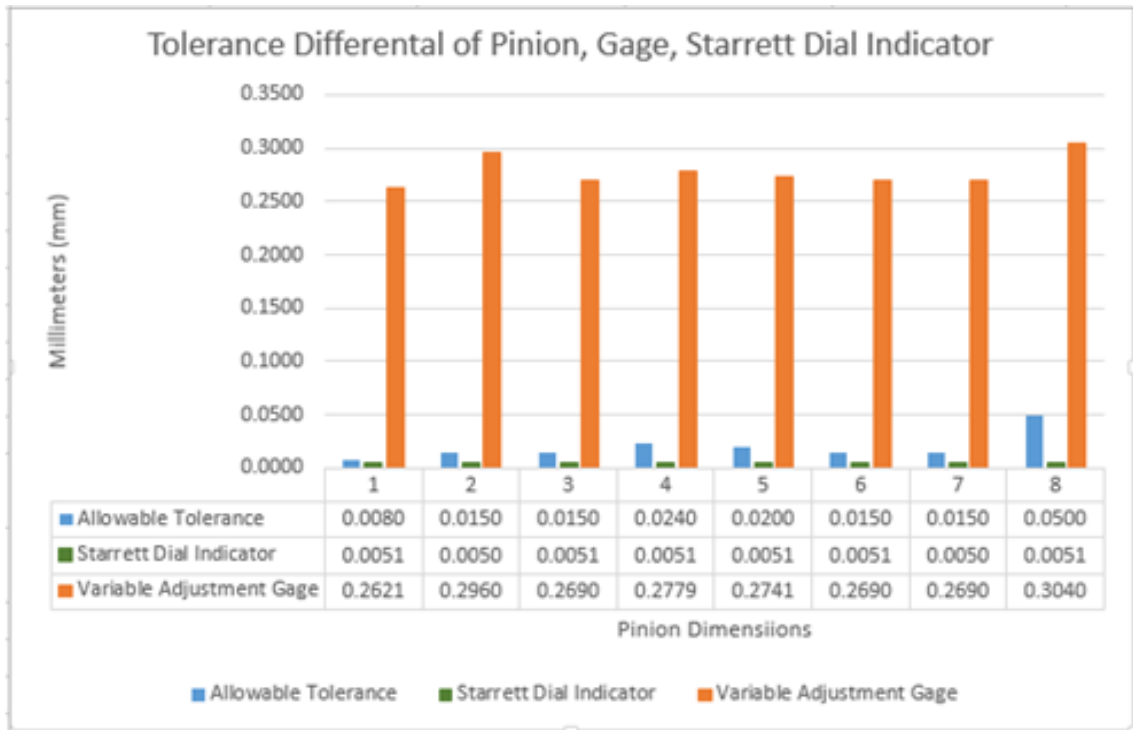

Figure 27: Comparison of Tolerance Differentials throughout Calculations

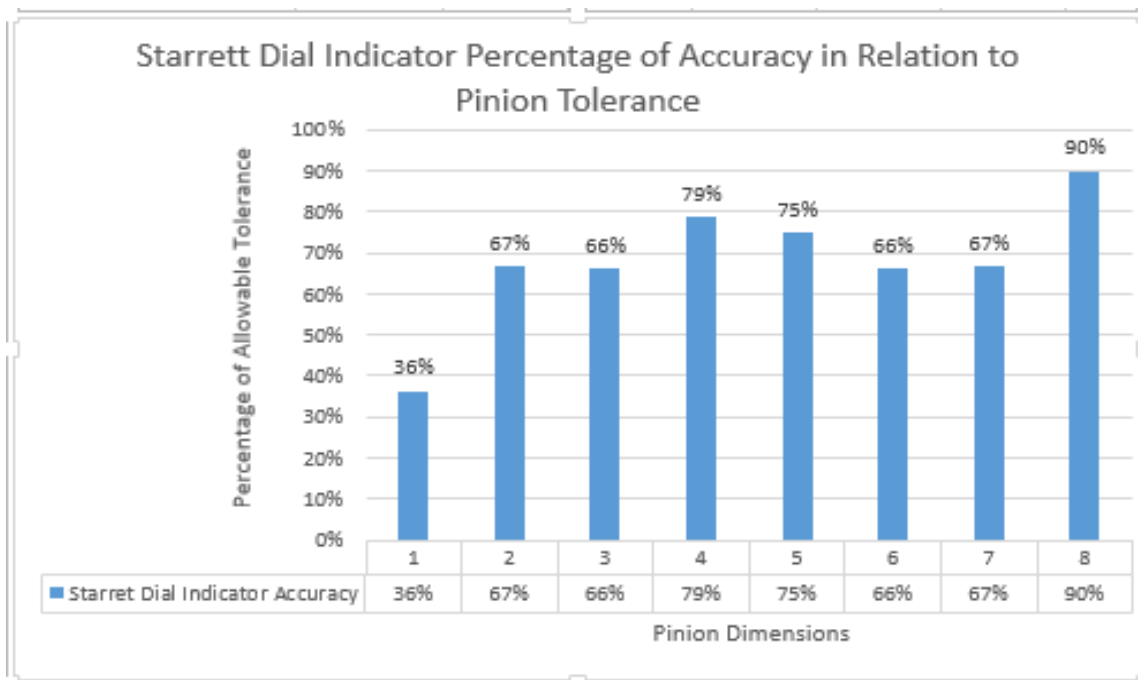

Figure 28: Starrett Dial Indicator Percentage of Accuracy in Relation to Pinion Tolerance

The process capability of the improved gage, as calculated by the Equations 6-8, was determined to be 1.14. This means that the tolerances measured with the Starrett gage are within the upper and lower specification limits of the pinion outer diameters, with some room to spare. Figure 29 illustrates how the data compares with the upper specification limits and lower specification limits in terms of magnitude of variance. The upper specification limit was defined as the minimum of the maximum allowed tolerance values, while the lower specification limit was defined as zero, which would be a measured outer diameter equal to the ideal OD from the pinion drawing.

$$C_{pl} = \frac{(\mu - LSL)}{3\sigma}$$

$\mu = \text{process mean}$

$LSL = \text{Lower specification limit}$

$\sigma = \text{standard deviation}$

Equation 6: Formula to Determine Process Bias toward Lower Specification Limits

$$C_{pu} = \frac{(USL - \mu)}{3\sigma}$$

$\mu = \text{process mean}$

$USL = \text{Upper specification limit}$

$\sigma = \text{standard deviation}$

Equation 7: Formula to Determine Process Bias toward Upper Specification Limits

$$C_{pk} = \min(C_{pl}, C_{pu})$$

Equation 8: Process Capacity Equation

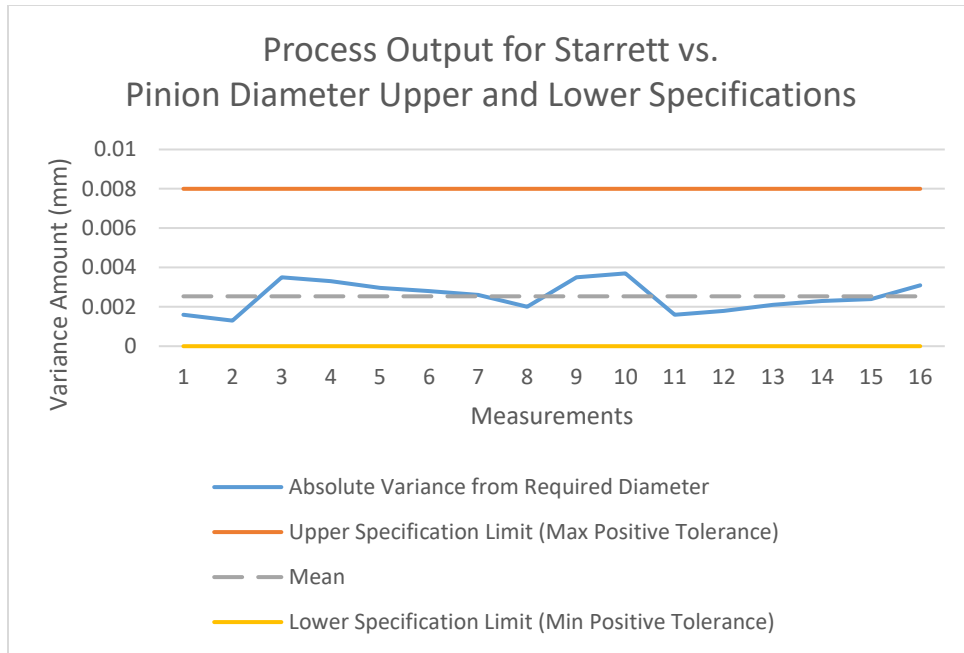

Figure 29: Process Performance Comparison on Specification Limits

The Variable Adjustment Gage designed to measure pinion outer diameters ultimately did not pass a First Article inspection for functionality, conducted by the team at the Primetals facility. Analysis of the design by and with industry experts lead to critiques and solutions which, after implementation, would lead to further testing and potentially increased accuracy in measuring the outer diameter of pinions for Primetals. Having a variable gage, like the one designed for this MQP, would reduce non-value added time spent preparing for pinion inspection, thus freeing up operator capacity to produce more pinions.

8.3. Gage Design Failure Analysis

The variable adjustment inspection gage is thoroughly designed to be utilized in an industrial setting such as the Primetals facility. Its durability allows it to be used over a long period of time. Yet, like other measurement devices, when mishandled or not delicately treated failures may occur. First, due to the weight of steel rods of the gage, users may find the device difficult to hold, thus increasing the chance to drop the gage. This ergonomic issue is due to the materials chosen to manufacture the prototype. The prototype rods are made out of steel due to the strength and durability of the material. In the prototyping phase the MQP team wanted to

minimize design costs. However, if Primetals engineers choose to pursue the design, it is recommended that the next prototype be made from aluminum. This material is just as durable as steel; however it is more lightweight and will be more ergonomically efficient. Comparisons of the materials can be seen in Appendix C. Example of comparisons is the difference in ultimate tensile strength between two materials.

If a force above 97 pounds (CustomPartNet, 2017) is applied to the steel rods in a perpendicular to their orientation, it will cause permanent plastic deformation of .01 inches, effectively ruining the utility of the gage. Due to the nature of the purpose of the gage this should not be a problem because it is not performing any operations where they would be put under that amount of stress. The MQP team recommends that WWC1 dedicate a space specifically to the universal gage for storage to avoid any risk of this weight being inadvertently applied to the gage.

In addition, if a similar level of force is applied to the device in a motion parallel to the direction of the rods, it will exceed the ultimate tensile strength of the frame, permanently deforming the frame of the device, and affecting its ability to measure properly. Other pieces affected by a large force, such as bolts holding the device together, may become bent, dented, or worn altering the accuracy and adjustability of this gage. There is also general wear and tear on the gage, which over time (15+ years) will affect the preciseness of the device. In the end, if the device is treated properly and not experiencing constant abuse it will remain in good condition.

The gage operates by rotating hex nuts located on the threaded rods to arrive at the desired location. This provides a precise measurement because it allows the operator to make fine adjustments to determine the exact OD needed. Yet, due to the possible miniscule movement of the hex nuts, an accurate measurement within $\pm .001$ " may not be achieved. In addition, since the device relies on the rotation of hex nuts, it may consume more time than anticipated, lowering the efficiency of the workstation.

8.4. Interdisciplinary Collaboration

The Primetals MQP project used methods of analysis from both of the majors associated with the team, industrial engineering and mechanical engineering, as well as communications, business, and sociology. The industrial engineers used time studies, created 5S audits, and identified waste to be reduced for the project. The mechanical engineer resolved one of the wastes associated with the process by designing and manufacturing a universal gage. Both majors worked hand-in-hand to calculate the process capability of the universal gage.

Communications was used along with business and sociology skills to work with management and machine operators associated with the WWC1 workstation at Primetals. This assisted in developing strong relations with both groups and allowed the operators to feel comfortable approaching the team about their personal thoughts on how to improve the process and for the team to determine what areas the operators were willing to change in the process. Most operators felt that their time was wasted trying to find jobs and when centering the pinions which the team identified as a larger source of waste and later resolved by having jobs be stored in the warehouse until needed and have unutilized labor center the pinions. Operators also expressed to the team the waste of time and aggravation they associated with searching for the proper gages which other operators take and forget to return or incorrectly store which was resolved by the team creating a universal gage specifically for WWC1 operators. By utilizing skills outside of the two major areas of knowledge of the team, they were able to further understand the processes behind Primetals' structure and created a level of trust with both management and the operators that proved critical to the project's success.

9. Conclusions

The WPI team worked with Primetals with the goal of reducing the cycle and set up time for the WWC1 workstation by 20% as well as standardizing the tools and processes involved in WWC1. The solutions implemented by the team resulted in a reduction in cycle time by 16% and reduction of setup time by 37%. In addition to these process improvements, the team also designed and manufactured a universal gage and implemented a 5S audit to standardize the process. Despite setbacks to this project, the team satisfied the demands of the Primetals sponsors and created a system of improvements that will continue long after the project is completed.

10. Future Recommendations

The Primetals MQP team recommends the implementation of Radio Frequency Identification System (RFID). RFID that utilize bar codes on individual products and parts which relay to a network system to keep track of inventory within a building (Bosnor & Fenlon, 2007). This tool is commonly used within cattle tracking and grocery stores, now is being employed worldwide by a plethora of businesses and companies to track their products (Bosnor & Fenlon, 2007).

The opportunity for implementation of RFID was noticed because of Primetals lack of a formal way to track tools and part inventory. Inventory was often moved from step to step in the process without any communication with management or the operators of the next step. Tools were often taken from one workstation to another without any form of tracking or accountability for the operators that took them to return them. The implementation for RFID is a smart, simple way to assist Primetals in eliminating nonvalue added time from searching and inventory tracking. It is also an excellent time frame for implementing an RFID solution because Primetals is rewiring the entire facility in the next two years. What would be costly to access the wiring needed for initial installation will be decreased greatly because the installation team will already have access to any needed facility infrastructure.

The Primetals MQP team suggest Primetals rely on one of the following companies to implement an RFID system within their facility: GAO RFID Inc., ID Technology, and Productivity by RFID. These three companies are all within an hour of the facility. They were chosen not only for their excellent history in industrial applications of RFID, but their superior customer support. If Primetals encounters any problems with implementing RFID, they will have ample continuous support. They provide full implementation services, which includes tags, readers, antennas, system, software, and any other additional accessories needed.

11. Appendices

11.1. Appendix A: Time Study Summary

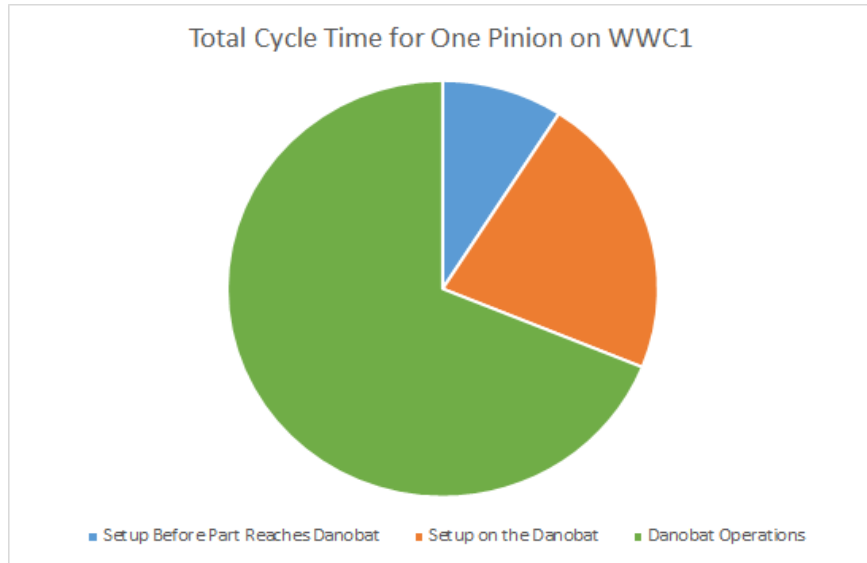

Figure 30: Visual Breakdown of Total Cycle Time for One Pinion on WWC1

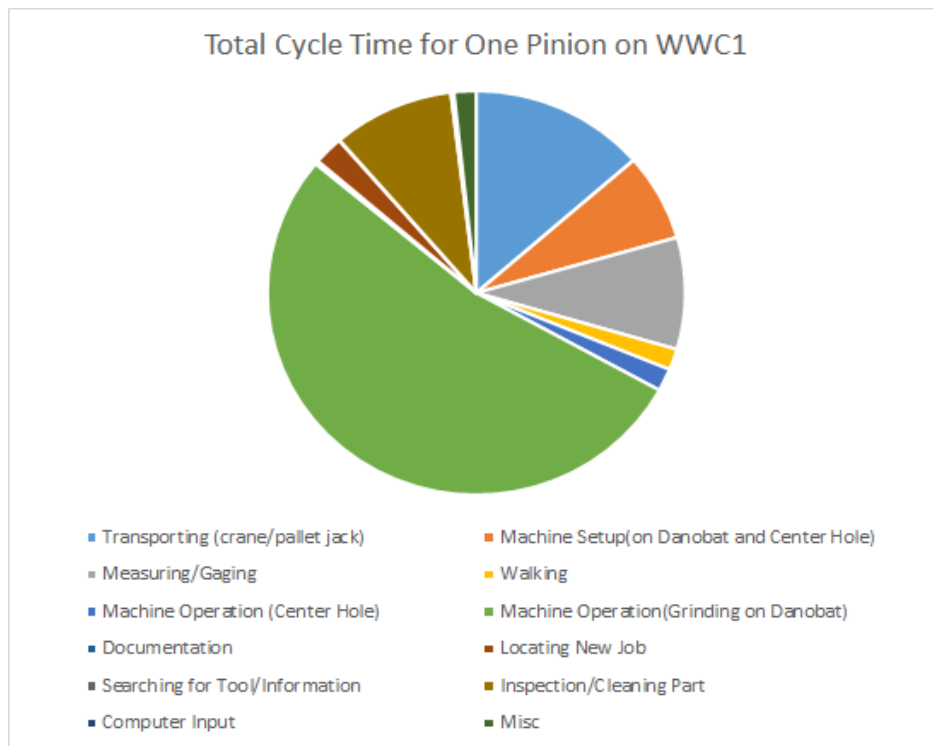

Figure 31: Total Cycle Time for One Pinion on WWC1 by Task Category

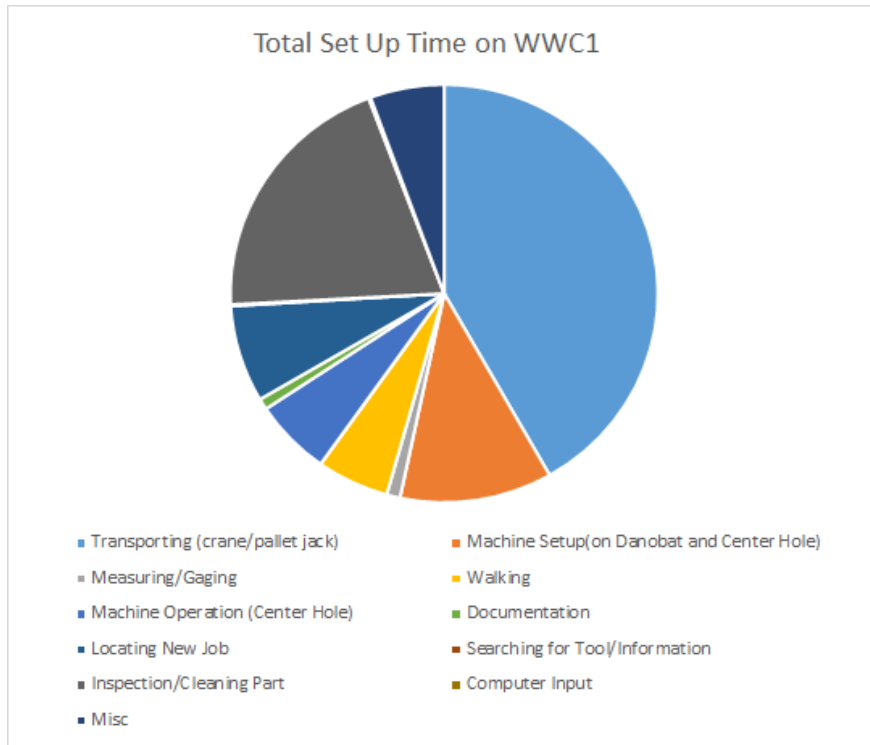

Figure 32: Total Setup Time for One Pinion on WWC1 by Task Category

11.2. Appendix B: Axiomatic Design

#	[FR] Functional Requirements	[DP] Design Parameters
0	Machining specific steps on pinion in WWC1 workstation	Method for machining specific steps on pinion in WWC1 workstation
1	Prepare pinion for machining	Method for preparation of pinion for machining
1.1	Find pinion	Method of searching for pinion
1.2	Move pinion X Y	Pallet Jack
1.3	Move pinion in Z	Crane
1.4	Mount pinion in machine	operator methods (wood blocks, machine alignment fixtures, trial and error)
1.5	Build gages for OD measurement	Gage blocks & job specifications
1.5.1	Check job paperwork for pinion specs	spec sheets/job paperwork
1.5.2	Find gage blocks and parts	gage parts and gage blocks
1.5.3	Construct gage	method for construction of gage
2	Grind pinion	Method of grinding of pinion
2.1	Grind center holes	Center hole grinding machine
2.2	Grind pinion OD	Method for grinding OD
2.2.1	probe OD	Manual probe of OD (Danobat probe when machine is fully operational)
2.2.2	grind OD	Machine program and grinding wheel
3	Inspect pinion	Method of inspection of pinion
3.1	Inspect center holes	Visual inspection
3.2	Measure OD of pinion	Gages built at begining of job
3.3	Clean pinion	Rags
3.4	Inspect for quality of grind	Visual inspection
4	Deliver pinion	Method of delivering pinion from Danobat and center grinding machine
4.1	Remove from machine	Manual effort, crane and pinion straps
4.2	Transfer pinion to skid	Crane and pinion straps

Figure 33: Axiomatic Design Model of the Current State of WWC1

	DP0	DP1	DP1.1	DP1.2	DP1.3	DP1.4	DP1.5	DP2	DP2.1	DP2.2	DP2.2.1	DP2.2.2	DP3	DP3.1	DP3.2	DP3.3	DP3.4	DP4	DP4.1	DP4.2	
FR0	X																				
FR1	X																				
FR1.1		X																			
FR1.2			X																		
FR1.3				X																	
FR1.4					X																
FR1.5						X															
FR2	X	X						X													
FR2.1								X													
FR2.2								X	X												
FR2.2.1										X											
FR2.2.2											X										
FR3	X	X											X								
FR3.1													X								
FR3.2					X									X							
FR3.3															X						
FR3.4																X					
FR4		X															X				
FR4.1				X														X			
FR4.2					X														X		X

Figure 34: FR-DP Dependency Matrix of Current State of WWC1

#	[FR] Functional Requirements	[DP] Design Parameters
0	Machining specific steps on pinion in WWC1 workstation, Dabotat	Method for machining specific steps on pinion in WWC1 workstation
1	Prepare pinion for machining	Method for preparation of pinion for machining
1.1	Move pinion X Y	Pallet Jack
1.2	Move pinion in Z	Crane
1.3	Mount pinion in machine	operator methods (wood blocks, machine alignment fixtures, trial and error)
1.4	Set universal gage to correct size	Gage blocks & job specifications
1.4.1	Check job paperwork for pinion specs	spec sheets/job paperwork
1.4.2	Adjust gage according to job specs	method for adjusting gage
2	Grind pinion	Method of grinding of pinion
2.1	Grind OD	Grinding wheel, program and probe on Danobat
2.1.1	probe pinion	Manual probe of OD (Danobat probe when machine is fully operational)
2.1.2	grind od	Machine program and grinding wheel
3	Inspect pinion	Method of inspection of pinion
3.1	Inspect center holes	Visual inspection
3.2	Measure OD of pinion	Gages built at beginning of job
3.3	Clean pinion	Rags
3.4	Inspect for quality of grind	Visual inspection
4	Deliver pinion	Method of delivering pinion from Danobat and center grinding machine
4.1	Remove from machine	Manual effort, crane and pinion straps
4.2	Transfer pinion to skid	Crane and pinion straps

Figure 35: Axiomatic Design Model of Proposed State of Outer Diameter Grinding

	DP0	DP1	DP1.1	DP1.2	DP1.3	DP1.4	DP1.4.1	DP1.4.2	DP2	DP2.1	DP2.1.1	DP2.1.2	DP3	DP3.1	DP3.2	DP3.3	DP3.4	DP4	DP4.1	DP4.2	
FR0																					
FR1	X																				
FR1.1		X																			
FR1.2			X																		
FR1.3				X																	
FR1.4					X																
FR1.4.1						X															
FR1.4.2							X	X													
FR2	X								X												
FR2.1										X											
FR2.1.1											X										
FR2.1.2												X									
FR3	X												X								
FR3.1														X							
FR3.2															X						
FR3.3																X					
FR3.4																	X				
FR4																		X			
FR4.1			X																X		
FR4.2		X																		X	

Figure 36: FR-DP Dependency Matrix of Proposed State of Outer Diameter Grinding

#	[FR] Functional Requirements	[DP] Design Parameters
0	Machining specific steps on pinion in WWC1 workstation, Centering Machine	Method for machining specific steps on pinion in WWC1 workstation
1	Prepare pinion for machining	Method for preparation of pinion for machining
1.1	Move pinion X Y	Pallet Jack
1.2	Move pinion in Z	Crane
1.3	Mount pinion in machine	operator methods (wood blocks, machine alignment fixtures, trial and error)
2	Grind center holes	Center hole grinding tip and manual effort on center grinding machine
3	Inspect pinion	Method of inspection of pinion
4	Deliver pinion	Method of delivering pinion from center grinding machine to Danobat queue
4.1	Remove from machine	Manual effort, crane and pinion straps
4.2	Transfer pinion to skid	Crane and pinion straps

Figure 37: Axiomatic Design Model of Proposed State of Center Grinding

	DP0	DP1	DP1.1	DP1.2	DP1.3	DP2	DP3	DP4	DP4.1	DP4.2
FR0	O									
FR1	X									
FR1.1		X								
FR1.2			X							
FR1.3				X						
FR2	X				X					
FR3						X				
FR4							X			
FR4.1			X					X		
FR4.2		X							X	

Figure 38: FR-DP Dependency Matrix for Proposed State of Center Grinding







11.3. Appendix C: 5S Audit Sheet

Location: WWC1		5S Audit Sheet		Date: 31/1/2017	
No Result	1	Slight Results	2	Average Results	3
			4	Above Average Results	4
				5	Outstanding Results
Category	Item	Grade	Comments		
Sort	There are no unnecessary tools/ equipment/paperwork in the workstation.	4	There are few unnecessary equipment.		
	Personal belongings are not in the workstation.	5	There wasn't any personal belonging.		
Straighten	Tools/equipment/machinery/paperwork is clearly labeled and placed identified location.	4	Chuck jaw and light are needed to be replaced		
	Locations for machinery, boxes, tools, etc. are clearly marked on the floor.	5	Everything is clearly marked		
Shine	All tools/equipment/floor are clean and in good condition.	5	All the cleaning equipment are usable		
	Cleaning equipment are in the workstation and available when needed.	5	Cleaning equipments are available		
Standardize	All tools/equipment are in their identified locations.	5	All the tools are in their locations.		
	Results of previous audit sheet is clearly visible to entire team.	0	There is no previous audit sheet available		
Sustain	Visual management board is up to date and followed by everybody.	1	VMB is not being used properly.		
	There is a specific 5S check sheet to keep applied 5S in the workstation.	5	The 5S check sheet is not being used.		
Total	The percentage of current 5S in the workstation.	78%			





















Figure 39: 5S Audit Sheet

11.4. Appendix D: Standard Work

11.4.1. Center Hole Grinding Standard Work

Slide 1	Slide 2
<p data-bbox="289 426 407 453"> PRIMETALS TECHNOLOGIES</p> <p data-bbox="289 464 639 531">Standardized Work: Center Grinding Operation</p> <p data-bbox="289 535 493 558">Pinions Family – WWC1</p> <p data-bbox="289 562 412 583">February 2016</p> <p data-bbox="289 588 350 609">Rev 01</p> <p data-bbox="289 613 566 634">NON CONTROLLED DOCUMENT</p>	<p data-bbox="873 436 992 464"> PRIMETALS TECHNOLOGIES</p> <p data-bbox="1013 436 1362 464">Step 1 – Place the part in the machine</p> <div data-bbox="857 478 1382 600"></div> <ul data-bbox="878 611 1321 684" style="list-style-type: none">• Pick up job from WWC1 queue with pallet jack and move to two-bin center grinding queue• Remove red magnet from next to job on board and place yellow magnet• Use crane to move part from two-bin center grinding queue to near center grinding machine• Pick up the part and place it in the machine for center grind• Est. time – 10 mins.
<p data-bbox="451 726 545 753">Slide 3</p>	<p data-bbox="1073 726 1167 753">Slide 4</p>
<p data-bbox="245 793 363 821"> PRIMETALS TECHNOLOGIES</p> <p data-bbox="386 793 751 821">Step 2 – Straighten the part and center grind</p> <div data-bbox="342 846 646 963"></div> <ul data-bbox="250 978 740 1062" style="list-style-type: none">• Make sure the part is straight after placing the chuck before centering the end• Measure with the gage for any runouts with tolerance of 10 µm• Clean the piece after the centering is done• Est. time – 10 mins	<p data-bbox="867 793 985 821"> PRIMETALS TECHNOLOGIES</p> <p data-bbox="1013 793 1248 821">Step 3 – Finish the job</p> <ul data-bbox="872 846 1097 1020" style="list-style-type: none">• Move completed job from center grinding two-bin system to Danobat two-bin system• Repeat for remaining 3 parts• Remove yellow magnet from finished job and replace with green magnet (signaling job completion)• Est. time – 5 mins <div data-bbox="1127 846 1373 1026"></div>

11.4.2. Danobat Outer Diameter Grinding Standard Work

<p style="text-align: center;">Slide 1</p> <p style="text-align: center;">  Standardized Work: Danobat Pinions Family – WWC1 February 2016 Rev 01 NON CONTROLLED DOCUMENT </p>	<p style="text-align: center;">Slide 2</p> <p style="text-align: center;">  Step 1 – Start the job on the Danobat </p> <div style="display: flex; justify-content: space-around;">    </div> <ul style="list-style-type: none"> • Write job number under Danobat column (if applicable) • Place yellow magnet next to job number • Pick up the job from two-bin center grinding queue with pallet jack • Pick up job from two-bin Danobat queue with the crane • Move part near Danobat • Est. time – 5 mins max
<p style="text-align: center;">Slide 3</p> <p style="text-align: center;">  Step 2 – Place the part in the machine </p> <div style="display: flex; justify-content: space-around;">    </div> <ul style="list-style-type: none"> • Place the part horizontally inside the machine with one end inside the chuck and the other end locked with the tail stock • Remove the supports from the bottom • Est. time – 15 mins 	<p style="text-align: center;">Slide 4</p> <p style="text-align: center;">  Step 3 – Runout Check </p> <div style="display: flex; justify-content: space-around;">    </div> <ul style="list-style-type: none"> • Measure the runout with the gage on top and bottom of the part • Tighten the chuck to straighten it and get it within tolerances • Est. time – 5 mins
<p style="text-align: center;">Slide 5</p> <p style="text-align: center;">  Step 4 – Setup the grinding & dressing wheel </p> <div style="display: flex; justify-content: space-around;">   </div> <ul style="list-style-type: none"> • Dress both the wheels with the program • Touch both wheels to the part to indicate the center and the shoulder • Est. time – 12 mins 	<p style="text-align: center;">Slide 6</p> <p style="text-align: center;">  Step 5 – Grinding process </p> <ul style="list-style-type: none"> • Start the program to grind the OD of the part • Intermediate checks for the OD of the part • Make corrections until the desired OD is achieved • Move finished part back to two-bin queue • Repeat steps 1-5 for the next 3 parts • Est. time per part – 190 mins <div style="text-align: right;">  </div>
<p style="text-align: center;">Slide 7</p> <p style="text-align: center;">  Step 6 – Finish the job </p> <ul style="list-style-type: none"> • Fill the move ticket for the next job • Remove yellow magnet from finished job and replace with green magnet (signaling job completion) • Est. time – 5 mins <div style="text-align: right;">  </div>	

11.5. Appendix E: Gage Design



Figure 40: Variable Adjustment Gage Frame Piece A



Figure 41: Variable Adjustment Gage Frame Piece B

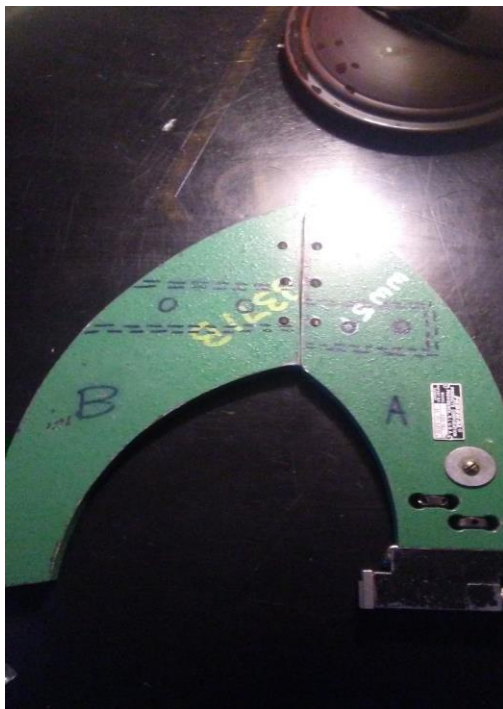

Figure 42: Variable Adjustment Gage Pieces Side by Side



Figure 43: L9 Alloy Hex Nuts



Figure 44: Socket Head Cap Screws

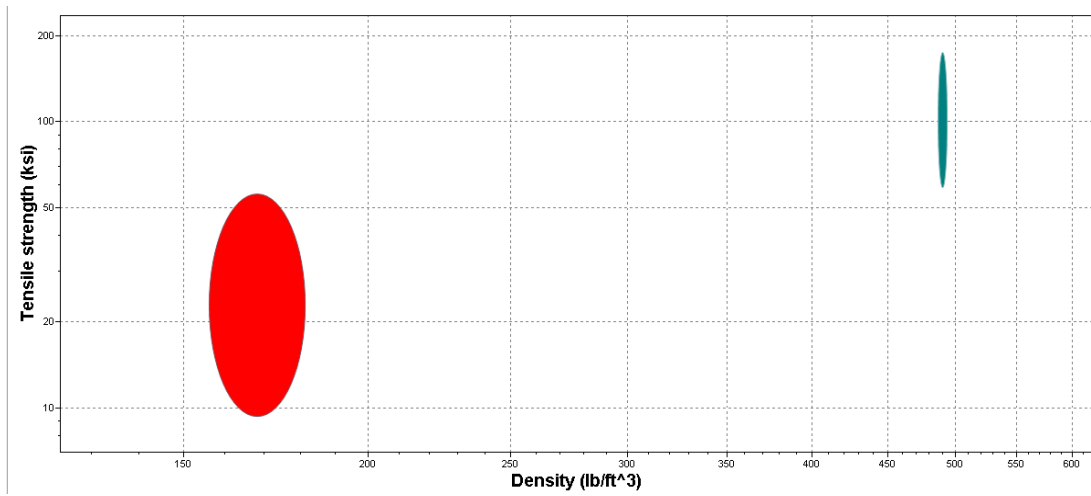

Figure 45: Tensile Strength Vs. Density of Aluminum (Red) & Steel (Blue)

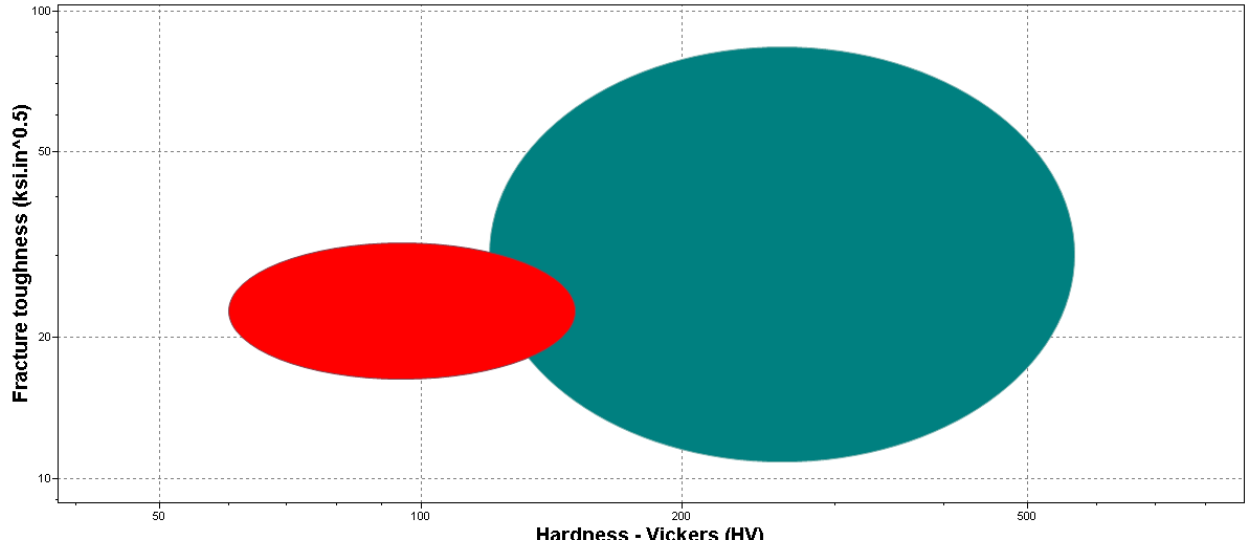

Figure 46: Fracture Toughness Vs. Hardness of Aluminum (Red) & Steel (Blue)

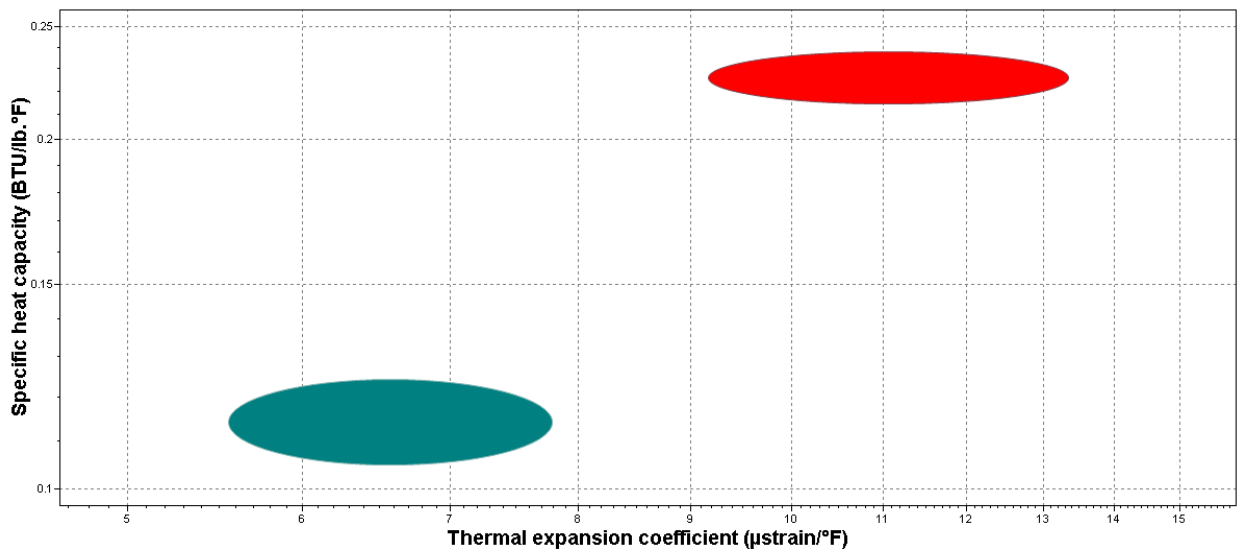
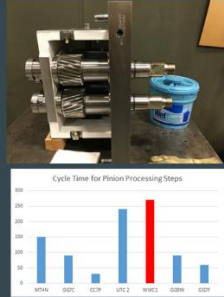
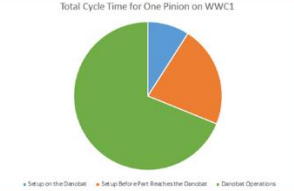

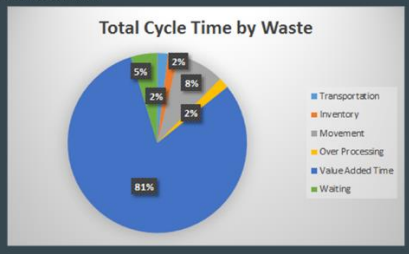
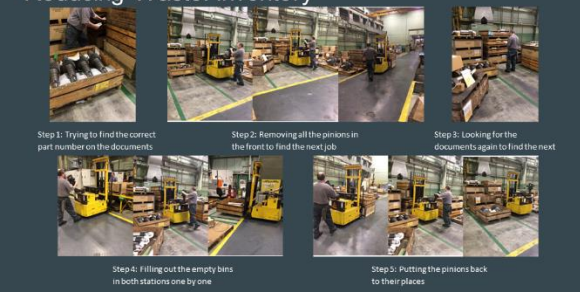
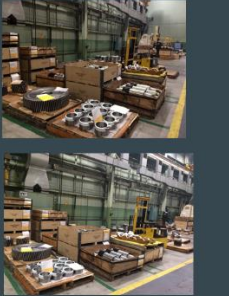

Figure 47: Specific Heat Vs. Thermal Expansion of Aluminum (Red) & Steel (Blue)

11.6. Appendix F: Presentation

<p style="text-align: center;">Slide 1</p> <h1 style="text-align: center;">Process Improvement at WWC1</h1> <p style="text-align: center;">...</p> <p style="text-align: center;">Emily Aldrich, Liz Bernier, Serra Onder, Molly Rockwood, Jack Viens</p>	<p style="text-align: center;">Slide 2</p> <h3>Project Goals</h3> <ul style="list-style-type: none"> • Reduce cycle time for pinions at WWC1 by 20% • Reduce setup time for pinions at WWC1 by 20% • Standardize tools and workplace procedure at WWC1 for pinion processing  <p>The bar chart shows cycle times for various steps: MTR (100), DEC (100), STP (100), WWC1 (200), GBR (100), and GPP (100). The WWC1 step is highlighted in red, indicating it is the focus of the project.</p>														
<p style="text-align: center;">Slide 3</p> <h3>Data Collection</h3>  <p>Total Cycle Time for One Pinion on WWC1</p> <ul style="list-style-type: none"> • Total Cycle Time: 5 hours 5 minutes • Total Setup Time: 1 hour 35 minutes • Setup Before Danobat: 1 hour 7 minutes • Setup on Danobat: 27 minutes • Danobat Operations: 3 hours 30 minutes 	<p style="text-align: center;">Slide 4</p> <h1 style="text-align: center;">Reducing Waste at WWC1</h1>														
<p style="text-align: center;">Slide 5</p> <h3>Identifying Waste</h3> <h4>The 7 Wastes of Lean</h4> 	<p style="text-align: center;">Slide 6</p> <h3>Data Collection</h3> <h4>Total Cycle Time by Waste</h4>  <table border="1"> <thead> <tr> <th>Waste Type</th> <th>Percentage</th> </tr> </thead> <tbody> <tr> <td>Transportation</td> <td>81%</td> </tr> <tr> <td>Inventory</td> <td>8%</td> </tr> <tr> <td>Movement</td> <td>5%</td> </tr> <tr> <td>Over Processing</td> <td>2%</td> </tr> <tr> <td>Value Added Time</td> <td>2%</td> </tr> <tr> <td>Waiting</td> <td>2%</td> </tr> </tbody> </table>	Waste Type	Percentage	Transportation	81%	Inventory	8%	Movement	5%	Over Processing	2%	Value Added Time	2%	Waiting	2%
Waste Type	Percentage														
Transportation	81%														
Inventory	8%														
Movement	5%														
Over Processing	2%														
Value Added Time	2%														
Waiting	2%														
<p style="text-align: center;">Slide 7</p> <h3>Reducing Waste: Inventory</h3>  <ol style="list-style-type: none"> Step 1: Trying to find the correct part number on the documents Step 2: Removing all the pinions in the front to find the next job Step 3: Looking for the documents again to find the next Step 4: Filling out the empty bins in both stations one by one Step 5: Putting the pinions back to their places 	<p style="text-align: center;">Slide 8</p> <h3>Reducing Waste: Inventory</h3> <ul style="list-style-type: none"> • 846 square feet of space dedicated to Bay 8 inventory • 162 square feet is assigned to WWC1 • Overflow of inventory of takes up 306 square feet of space • Currently takes 22 minutes per job (2% of processing time per pinion) to sort through inventory 														

Slide 9

Reducing Waste: Inventory

- New inventory management system
- Inventory will stay in off-site inventory warehouse when returning from plating until needed
- Only 5 jobs/machine cell workstation should be present at a time for Bay 8 inventory
- Up to 654 ft² of floor space freed up for value added tasks

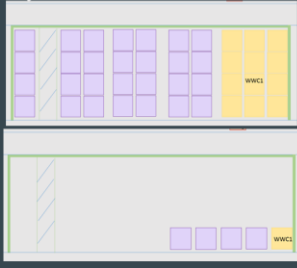

Slide 10

Axiomatic Design: Uncovered Waiting Waste

FR1 Functional Requirements	FR2 Design Parameters
1.1 Grinding specific holes on pinion in WWCI workstation	Method for machining specific holes on pinion in WWCI workstation
1.2 Prepare pinion for machining	Method for preparation of pinion for machining
1.3 PinD pinion	Method of searching for pinion
1.4 Pinion in Y	Pinion tool
1.5 Pinion in Z	Crane
1.6 Mount pinion in machine	operator methods (wood blocks, machine alignment fixtures, trial and error)
1.7 Mount gages for OD measurement	Gage blocks & pin specifications
2.1 Center pinion	Method of grinding of pinion
2.2 Grind center holes	Center hole grinding to and manual effort on center grinding machine
2.3 Pinion OD	Grinding wheel, program and pins on Danobat
2.4 Pinion OD	Manual pinion OD (Danobat probe when machine is fully operational)
2.5 Pinion OD	Machine program and grinding wheel
3.1 Inspect center holes	Method of inspection of pinion
3.2 Measure OD of pinion	Visual inspection
3.3 Check pinion	Gages built at beginning of job
3.4 Inspect for quality of grind	Visual inspection
4.1 Center pinion	Method of delivering pinion from Danobat and center grinding machine
4.2 Remove from machine	Transfer wheel, crane and pinion straps
4.3 Transfer pinion to sled	Crane and pinion straps

Slide 11

Reducing Waste: Waiting

- Currently spending 15 minutes/pinion (5% of cycle time) on the center hole operation
- Decoupling center hole operation from Danobat standard work

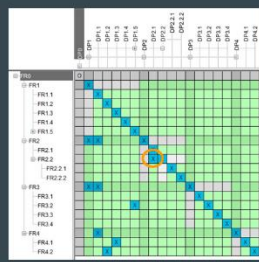

Slide 12

Reducing Waste: Transport

- Job queuing was identified as a huge transport waste in terms of:
 - Walking
 - Inventory movement
 - Retrieving equipment (crane and pallet jack)
- Average of 6 minutes (2% of total time) spent on transportation



Current Process

Slide 13

Reducing Waste: Transport



Operator transportation waste of walking

Slide 14

Reducing Waste: Motion

- Currently taking 24 minutes per pinion (8% of total processing time)
- Light
- Chuck jaw
- Gage

Slide 15

Reducing Waste: Motion - Light



Old Light



New Light

Slide 16

Reducing Waste: Motion - Chuck Jaw

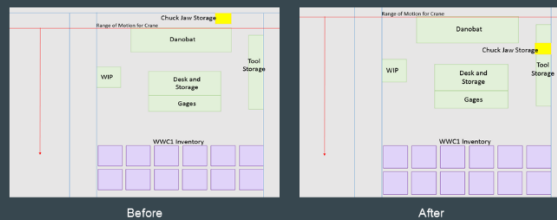

Before

After

Slide 17

Reducing Waste: Motion - Gage Design



- Currently creating gages from scratch
- Parts are often missing from WWCI
- Spending 28 minutes per job

Slide 18

Reducing Waste: Motion - Gage Design

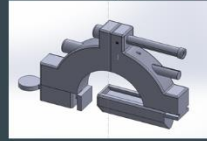

- Process: requirements needed, Solidworks design, Manufacturing, Assembly
- Precise to meet the demands of Primetals facility
- Adjustable to fit range of pinion dimensions
- Simple design for efficient and easy use

Slide 19

Gage Tolerance Stack-up Analysis

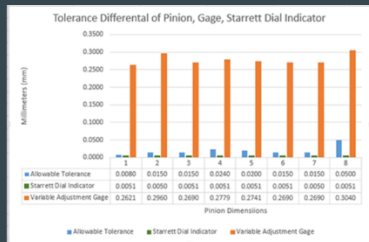

Slide 20

Reducing Waste: Over Processing

- WWCI must currently convert from metric to standard then back to metric
- High risk of human error
- Standardize measurements in engineering department
- New Conformance Report will include standard and metric
- Metric to fulfill customer design requirement

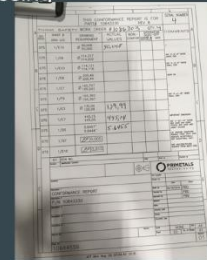

Slide 21

Standardizing Work at WWCI

Slide 22

5S Audit

Location: WWCI		5S Audit Sheet		Date: 3/3/2017
1	2	3	4	5
Subtotal	Slight Results	Average Results	Above Average Results	Outstanding Results
Category	5	4	3	2
Sort	There are no unnecessary tools/equipment/paperwork in the workstation.	Personal belongings are not in the workstation.	There are few unnecessary equipment.	There was not any practical hanging.
Straighten	Tool/equipment/machinery/paperwork is clearly labeled and placed identified.	Locations for machinery, boxes, tools, etc. are clearly marked on the floor.	All tool/equipment/box are clean and in good condition.	All the drawing equipment are at table.
Misc	Cleaning equipment are in the workstation and available when needed.	All tool/equipment are in their identified locations.	Results of previous audit sheet is clearly visible to entire team.	Cleaning equipment are available.
Standardize	Visual management board is up to date and followed by everyone.	There is a specific 5S check sheet to keep applied 5S in the workstation.	There is no previous audit sheet available.	5S is not being used properly.
Sustain	The percentage of correct 5S in the workstation.			
Total			78%	

Slide 23

Redefined Standard Work

- Separation of role responsibilities for center hole grinding vs. OD
- Visual management board
- Gage

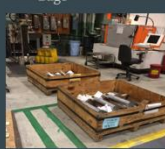

Slide 24

Impact of Solutions

Slide 25



Slide 26

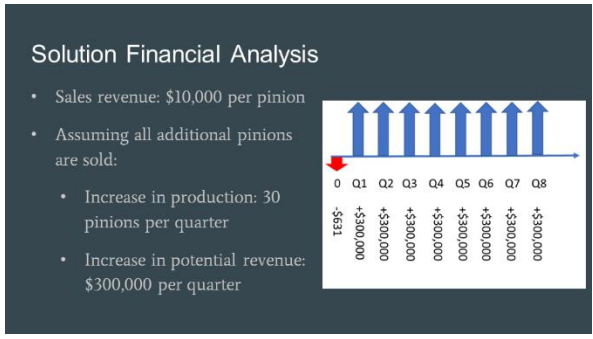

Slide 27

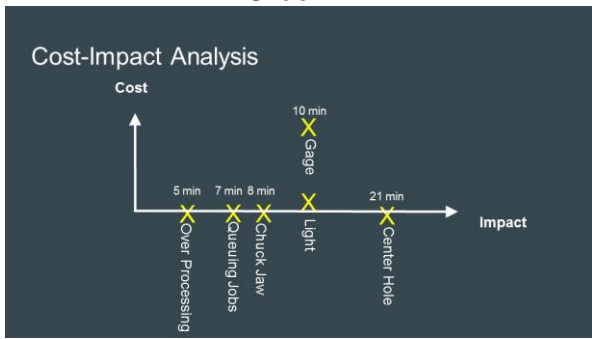

Slide 28

Conclusions

- 39% reduction in setup time
- 16% reduction in cycle time
- Standardized tools and processes
- Removed sources of waste with minimal financial investment

Slide 29

Future Recommendations

Slide 30

Future Recommendations

- Implementation of RFID
- Main Goal: Keeping track of inventory within a building
- Suggested Companies: GAO RFID Inc. / ID Technology / Productivity by RFID
- Service provided: Full implementation (tags, readers, antennas, system, software, etc.)

Slide 31

From the WPI MQP Team:
**Thank You,
 Primetals**

12. References

Bosnor, K., & Fenlon, W. (2007, November 05). How RFID Works. Retrieved February 06, 2017, from <http://electronics.howstuffworks.com/gadgets/high-tech-gadgets/rfid.htm>

Bostock, M. (2017, February 2). Epicyclic Gearing. Retrieved February 06, 2017, from <https://bl.ocks.org/mbostock/1353700>

Brown, C. (2013, April 15). *An Introduction to Axiomatic Design as a Scientific Discipline*. Lecture presented in Worcester Polytechnic Institute, Worcester, Massachusetts. Retrieved August 1, 2016, from <https://www.youtube.com/watch?v=WimzxRJhWs&t=1809s>

By the end of World War II, outside investors held nearly one-half of the equity. (n.d.). Mitsubishi.com - About Mitsubishi - Origin -. Retrieved October 10, 2016, from <https://www.mitsubishi.com/e/history/>

Career. (2016). Retrieved October 10, 2016, from <http://www.primetals.com/en/careers>

Chandra, P. V. (2013, June 25). 12 Essential Lean Concepts and Tools. Retrieved October 10, 2016, from <http://www.processexcellencenetwork.com/lean-six-sigma-business-transformation/articles/12-essential-lean-concepts-and-tools>

Colby, P. (October 30th, 2016). Bay 8 Tool Checkout System [Interviewed by M. Rockwood]

Columbus McKinnon Corporation. (n.d.). 6S Training Overview. Retrieved October 12, 2016, from http://www.ntma.org/uploads/general/6S_Training.pdf

CustomPartNet. (2017, February 06). V-Bending Force Calculator. Retrieved February 06, 2017, from <http://www.custompartnet.com/calculator/v-bending-force>

GAO RFID. (n.d.). GAO RFID Serves Boston, Massachusetts. Retrieved December 5, 2016, from <http://gaorfid.com/gao-rfid-in-boston-massachusetts/>

Gontarek, R., Junk, B., Rahl, Z., Raymond, E., & Thompson, L. (2016, April 23). Manufacturing Capacity Simulation at Primetals Technologies. Retrieved October 10, 2016.

Grainger. (2017, January). Westward Rechargeable Lantern [Digital image]. Retrieved February 05, 2017 from <https://www.grainger.com/product/WESTWARD-Rechargeable-Lantern-5RHN0>

ID Technology. (n.d.). RFID Solutions. Retrieved December 5, 2016, from <http://www.idtechnology.com/products/rfid-solutions/>

ISixSigma. (2017, January). 8 Wastes of Lean. Retrieved February 05, 2017, from <https://www.isixsigma.com/dictionary/8-wastes-of-lean/>

Jenni, M. (Director). (2014, November 9). Manufacturing a Steel Pinion [Video file]. In Key Lean Manufacturing Principles. (2016). Retrieved October 10, 2016, from <http://www.lean-manufacturing-junction.com/lean-manufacturing-principles.html>

Johnson, T. G.(2010). Wheel and Pinion Cutting. Retrieved October 6, 2016, from <http://www.csparks.com/watchmaking/WheelCutting.html>

Joshi, P. H. (2007). *Machine Tools Handbook: Design and Operation*. New York: McGraw Hill Education.

Kaizen Institute. (2015, July 22). The 7 Wastes of Production. Retrieved February 15, 2017, from <https://in.kaizen.com/blog/post/2015/07/22/the-7-wastes-of-production.html>

Lean Enterprise Institute. (2016). What is Lean?. Retrieved October 10, 2016, from <http://www.lean.org/WhatsLean/>

Lean Manufacturing Tools. (2016). Lean 6S; 5S+Safety. Retrieved October 10, 2016, from <http://leanmanufacturingtools.org/210/lean-6s-5s-safety/>

Lean Production. (2016). Top 25 Lean Tools. Retrieved October 10, 2016, from <http://www.leanproduction.com/top-25-lean-tools.html>

Marc Jenni. (2014, November 9). Manufacturing a Steel Pinion. Retrieved October 6, 2016, from <https://www.youtube.com/watch?v=cBu22obGHYc>

MassMEP. (2016). *Value Stream Analysis: Pinions* (Rep.). Worcester, MA: MassMEP.

Maxim, E. A. (2011). Types of Gear. Retrieved February 06, 2017, from echnicalmania.blogspot.com/2011/07/types-of-gear.html

Mitsubishi. (2016). About Mitsubishi. Retrieved October 10, 2016, from <http://www.mitsubishi.com/e/group/about.html>

Mitsubishi. (2016). Origin. Retrieved October 10, 2016, from <http://www.mitsubishi.com/e/history/index.html>

Mitsubishi Heavy Industries. (2016). Corporate Overview. Retrieved October 10, 2016, from <https://www.mhi-global.com/company/aboutmhi/outline/contents/index.html>

Moisan, J. (2017, February 17) Gage Improvements [Personal Interview]

Operator 1 (2016, September 14). Pinion Measuring Process [Interview by J. Viens].

Ortega A.(January 22,2017). Pinion Financial Analysis [Interviewed by E. Aldrich]

Ortega, A. (December 10th, 2016). Pinion Value Analysis [Interviewed E. Bernier]

Paul, B. (1979). Kinematics and dynamics of planar machinery. Englewood Cliffs, NJ: Prentice-Hall.

Phillips, G. (2014, April 11). The Basics of Gage R&R. Retrieved October 10, 2016, from <http://www.qualitydigest.com/inside/metrology-article/basics-gauge-rr.html>

Primetals. (2016). Company Profile. Retrieved October 10, 2016, from <http://primetals.com/en/about-us/company-profile>

Primetals. (2016). Corporate Organization. Retrieved October 10, 2016, from <http://primetals.com/en/about-us/corporate-organization>

Primetals. (2015, May). Metal Magazine: Innovation and Technology for the Metals Industry. Retrieved October 10, 2016, from http://primetals.com/en/pressandmedia/Issue%201%202015/Documents/020_Metals-Magazine_1-2015_Primetals-Technologies-and-METEC.pdf

Primetals. (2016). Primetals Technologies - The Global Authority in Metals Excellence. Retrieved October 10, 2016, from http://www.primetals.com/en/about-us/company-profile/Lists/FurtherInformation/Primetals_Brochure-EN.pdf

Productivity by RFID. (n.d.). Welcome to Productivity by RFID. Retrieved February 5, 2016, from <http://www.productivitybyrfid.com/>

Siemens. (2016). Our Business. Retrieved October 10, 2016, from <http://www.siemens.com/about/en/businesses/>

Siemens. (2016). Metals Technologies. Retrieved October 10, 2016, from <http://www.siemens.by/en/products/industry/metals-technologies/>

Siemens. (2016). Worldwide Presence. Retrieved October 10, 2016, from <http://www.siemens.com/about/en/worldwide.htm>

Simon, W. (2008, January 2). Siemens to Acquire Morgan Construction Company. Retrieved October 10, 2016, from http://www.siemens.com/press/pool/en/pr_cc/2008/01_jan/is11076786e.pdf

Starrett Products Precision Guide [PDF]. (2013, May). Athol: The L.S. Starrett Company.

Uicker, J. J., Pennock, G. R., & Shigley, J. E. (2003). Theory of Machines and Mechanisms. New York, NY: Oxford University Press