

# Design of an Automated Park Brake Release System For Towing



A Major Qualifying Project Report

Submitted to the Faculty of the

Worcester Polytechnic Institute

in partial fulfillment of the requirements for the

Degree of Bachelor of Science

By:

---

Simon Yeung (CE)

---

Adrian Ramirez (CE)

In Partnership with Shanghai University and Partners

Zuochi Han, Jifei Zhang, Xueming Nie

Date: February 20, 2012

Approved:

---

Professor Yiming (Kevin) Rong, Advisor, WPI, ME

---

Professor Tahar El-Korchi, Co-Advisor, WPI, CE

## **Abstract**

This project calls for a safer and customer efficient design of a park brake release system that is automated through a tow hook design. Due to the current design of the park brake release system, a spring loaded switch must be used to release the parking brakes. An additional customer add-on part must also be included onto the counterweight for another vehicle to latch onto the disabled vehicle to tow it away. With these limitations, we are to further implement a mechanical or electrical mechanism to automatically set off the park brake release system once our tow hook design is latched onto the shaft in the rear side of the disabled vehicle.

## Contents

Chapter 1, Introduction .....	5
Problem Statement.....	5
Opportunity Statement.....	5
Objectives .....	6
Accomplishments.....	7
Chapter 2, Background .....	8
History of the Company .....	8
Caterpillar Today.....	11
980H Wheel Loader .....	12
FIGURE 2.3: CUSTOM HOOK FOR 980H WHEEL LOADER .....	13
Automated System Need .....	14
Chapter 3, Methodology.....	16
Introduction .....	<b>Error! Bookmark not defined.</b>
Constraints .....	18
Parking Brake .....	20
Chapter 4, Results.....	22
Design.....	22
Transmission Mechanism Design.....	35
Actuation Design.....	37
Material Selection.....	40
Factor of Safety .....	41
Cost Analysis .....	42
Chapter 5, Conclusion .....	44
Recommendations.....	44
Chapter 6, References.....	46
Section 6, Appendix .....	<b>Error! Bookmark not defined.</b>
List of Figures .....	<b>Error! Bookmark not defined.</b>
FIGURE 10: PULLEY CABLE SELECTION.....	<b>Error! Bookmark not defined.</b>
List of Tables .....	<b>Error! Bookmark not defined.</b>

TABLE 3.1: PULLEY CABLE SELECTION ..... **Error! Bookmark not defined.**

## Acknowledgements

We would like to thank the following people for their support in helping us with the successful completion of this project:

Scott Panse, Caterpillar Engineer, China

Professor Rong, WPI

Professor El Korchi, WPI

Professor Jia, SHU

## **Chapter 1, Introduction**

The steel mill industry is a relatively new branch for Caterpillar. Since 1963, they have been helping customers around the world in the mining industry. They began with the 980 medium wheel loader; from there they developed two different machines. Today they have a complete line of wheel loaders in many different configurations to meet the requirements in all regions of the world. The 980H Medium Wheel Loader and the 990H Large Wheel Loader are designed to work in the steel mill industry. The focus of our project is the 980H Medium Wheel Loader shown in Figure 1.1. Due to the nature of its purpose, this vehicle is exposed to extremely high temperatures and a harsh environment. Is this same harsh environment that makes the braking system falter sometimes in the slag pit. There is a wide variety of clientele for this vehicle and they are able to come up with solutions for with these inconvenient mishaps on their own. It is Caterpillar's intention to be able to provide a solution for all of its clients and create a uniform solution for all.

### **Problem Statement**

The H-Series Medium Wheel Loader Steel Mill Arrangement currently contains a ground level switch to override and release the parking brake to be able to pull the vehicle from the metal slag pit. This design requires an employee to approach the disabled machine which is not feasible in some circumstances due to the hazards of the extremely high temperatures around the metal slag pit.

### **Opportunity Statement**

There is heavy consumer interest for an automatic park brake release system on still mill machines which can override the parking brake allowing the disabled vehicle to be pulled and towed away from the metal slag pit from behind, avoiding the necessity of an employee coming in harm's way trying to approach the machine. The automated park brake release system will be activated when tow force is applied to a disabled machine from behind. This feature is highly desired by Caterpillar's steel mill customers and can provide a considerable enhancement to the steel mill arrangement offered by CSCL.

The main purpose for this project is to provide Caterpillar's engineers with a possible solution to the company's current challenges in providing a standardized automatic parking brake release system activated by tow force. However, due to the short period we have to work on this design, we have limitations as to how far we can go with the design. Nevertheless, our design ideas could prove valuable to the company's final design.

## Objectives

For this project we were given some specifications on what the company wanted from the design. It was difficult for us at the beginning to grasp what specifically the company really wanted out of our design, since it seemed there was already a solution in place for the problem. Thus, we had a meeting with them about the problems they were facing and talked to them about the key uses of the design they were looking for. Therefore, we formulated a list of objectives to guide us through the successful completion of these requirements

- Automated/Spring loaded tow hook design activated by tow force
- Design transfer mechanism connected to the tow pin
- Design will activate and deactivate the switch and also keep switch as a fail safe

- Design and Validation

## **Accomplishments**

By the end of the project we were able to provide Caterpillar engineers with helpful ideas and concepts for the design which could be implemented in their final design. We provided a design that not only had to accommodate to the rigors of the high temperature and the stresses but also we had to make a design that was economical and practical. These wheel loaders compose only a portion of Caterpillar's product line, thus to accommodate for the requirements we designed a simple and cost effective tow hook with multipurpose use so that it met the requirements of the company

## Chapter 2, Background

Caterpillar has been leading the industry of machinery for a long time, it is their commitment to superior service that allows them to be the preferred company for machinery needs for clients around the world. Caterpillar finds pride in providing the best service to its clients, that is why when the problem with the 980H Wheel Loader emerged, they stepped up to offer a solution for its clients, to make their experience with their products smoother. They have dedicated months in designing an automated tow hook system that can be implemented with ease by its clients.

### History of the Company

Steam tractors in the late 19<sup>th</sup> century into the 20<sup>th</sup> century (Figure 2.1) were extremely heavy weighing up to 1000 pounds per horse power and often sank into the soft earth. Then, Benjamin Holt of Holt Manufacturing Company attempted to fix the problem by increasing the contact area of the tractor with the soil and thus spreading the force, by increasing the size and width of the wheels. However, this made the tractors increasingly complex, expensive and difficult to maintain.





FIGURE 2.1: 19<sup>TH</sup> CENTURY TRACTOR

Then on Thanksgiving Day, November 24, 1904, he successfully tested a prototype that wrapped the planks around the wheels. He replaced the wheels on a 40 horsepower Holt steamer. One of the company's photographers Charles Clements observed that the tractor worked as a caterpillar, Holt thought that was the perfect representation of his machine and caterpillar was born. Two years later Holt sold his first steam-powered tractor crawlers. Holt received the first patent for a practical continuous track for use with a tractor on December 7, 1907 for his improved "Tractor Engine".

Holt bought an empty factory plant that had been recently built to manufacture farm implements and steam traction engines in East Peoria, Illinois. In February 2, 1910 he opened the plant and started with 12 employees. Holt trademarked the name Caterpillar on August 2, 1910.

Caterpillar's tractors played a crucial role in World War I. Roughly 1,200 tractors were shipped to England, France and Russia for agricultural purposes; however, they were used in the battlefield hauling artillery and supplies. The Holt tractor was put through a series of tests at Aldershot. The British were very impressed with its performance and chose it as a gun tractor. Thus, over the next four years the Holt tractor became a major artillery tractor.

Holt died in late 1920 at 71 years old due to a month long illness. Thomas A. Baxter was to succeed Holt as head of the company. Baxter initially cut the large tractors from the product line and introduced smaller trucks focused on the agricultural market. The Federal Aid Highway Act of 1921 re-directed Baxter's focus on building road construction machines.

C.L. Best Gas Tractor Company formed by Clarence Leo Best in 1910 was Holt's primary Competitor. Both companies had been adversely impacted by the transition from the wartime to peacetime economy. The two companies finally merged in April and May 1925 creating Caterpillar Tractor Company. The company moved to Peoria under the terms of merger and Best assumed the title of CEO until 1951. Caterpillar consolidated its product lines from both companies and continued growth throughout the Great Depression of the 1930s.

Caterpillar's expansion at the global level came in 1950, becoming a multinational corporation. It built its first Russian facility in the town of Tosno, where it was constructed under harsh winter conditions and it was occupied in November 1999. Another facility was built in Suzhou, China to open business in the Asian market. Caterpillar has manufactured in Brazil since 1960. Although Caterpillar increased its sales of its core products, much of Caterpillar's growth has been through acquisitions of different companies that are experts in their own line of work, such as Trackson, Towmotor Corporation, Kato Engineering among others.

Presently, Caterpillar owns a large variety of business lines and they are: machinery, on road trucks, engines, and financial products

## Caterpillar Today

Caterpillar is one of the largest companies who manufacture construction and mining equipment, engines, industrial gas turbines, and locomotives. It was founded in 1925, with its headquarters based in Peoria, Illinois United States, and with a recorded amount of 125,099 employees in 2011.<sup>1</sup> The company serves customers in more than 180 countries with 300+ products. More than half of Caterpillar's sales are overseas. They hold more than 500 locations worldwide with manufacturing plants, distribution centers, logistics, and related facilities. By the end of 2011, the company recorded revenue of \$60,138 million, which was an increase of 41.2% from 2010. Their net profit was \$4,928million dollars in 2011, which was also an increase of 82.5% from 2010.<sup>2</sup>

A global leader in size, scope, reach and character, Caterpillar Inc. is a genuine enabler of sustainable world progress and opportunity, defined by the brand attributes of global leadership, innovation, and sustainability. For more than 85 years, Caterpillar Inc. has been making sustainable progress possible while making positive change on every continent. Caterpillar is the world's leading manufacturer of construction and mining equipment, diesel/natural gas engines, industrial gas turbines and diesel-electric locomotives.

There is an ongoing and intensive competitive pressure in the construction machinery business. Some of Caterpillar's competitors include Komatsu, Volvo, CNH, Deere, Hitachi, J.C. Bamford, and Doosan Infracore. Caterpillar is gaining a lot of expansion opportunities in China; they have recently signed an agreement for a new wheel loader manufacturing facility in Tong

---

<sup>1</sup> <http://www.caterpillar.com/company/global-footprint>

<sup>2</sup> <http://web.ebscohost.com/ehost/pdfviewer/pdfviewer?vid=3&hid=14&sid=12ec539f-b886-4635-8414-0d8106b266ef%40sessionmgr10>

Zhou, and they announced a new manufacturing facility project in Xuzhou, China. These new facilities and future models mark the start of Caterpillar's growing infrastructure to meet China's customer demands.<sup>3</sup>

Caterpillar's production system is dictated by four factors, which are: People, Quality, Velocity and Cost. They pride themselves in these values and demonstrated it to us on our site visit to one of the company's locations in China through the meticulous process each product went through before it was released to the public

### **980H Wheel Loader**

The 980h wheel loader comprises of a EPA tier 3 engine model with a gross power of 393 hp. It holds a general purpose bucket which is 5.7 m<sup>3</sup>, and it operates with a weight of up to 67,294lb. With the same bucket, its static tipping load is 42,989 lb. The vehicle has a new hood where they improved the actuation system. The electro-hydraulically activated twin lift cylinders were added to reduce lift and lower time. In the setting of the steel mill applications, the vehicle arrangements includes steel guarding, extreme service transmission, heavy-duty engine, hydraulic hose protection, insulated battery mounting, remote engine shutdown, remote parking brake release, transmission override, steel cable ladder, and other optional applications.

---

<sup>3</sup> <http://subscriber.hoovers.com/H/company360/overview.html?companyId=1030400000000>



FIGURE 2.2: 980H MEDIUM WHEEL LOADER

Caterpillar only produces a handful of the still mill arrangement 980H wheel loaders. Currently their clients order a separate part (*shown in Figure 2.3 below*) that functions as a custom hook to pull it out of the slag pit. There is a need for Caterpillar to provide this kind of hook for the client to satisfy all of his needs and improve his experience with CAT products.



FIGURE 2.3: CUSTOM HOOK FOR 980H WHEEL LOADER

## Automated System Need

Our project is not to design an automated parking brake release system to fix any current issues or problems. There is nothing wrong with the 980H wheel loader. Technically speaking, our project scheme is to only design a system where it is more suitable for Caterpillar customers to tow the wheel loader. Towing itself also hasn't been a big issue because customers have been designing their own tow hooks on the rear side of the wheel loader to be towed. The mission of our design is to improve on the method and process of how our customers tow the disabled wheel loader. The reason why this process needs to be improved is defined by the problem statements of our project. The biggest problem is the predicament of having a worker to manually engage the electrical switch and having to be exposed to very high temperatures. Another question could rise as whether this design has already been completed or why hasn't it been designed yet. Caterpillar provided a simple answer to these types of questions. For instance, Caterpillar describes it as that they had been working on developing such an automated system, but they are having the issue of how it could be accomplished. Currently, they have numerous tow hook designs that could incorporate the use of the tow pin. Their objective was to achieve a simple tow hook design that also advantageous to having various towing capabilities. The only reason that they haven't incorporated the tow hook design to present to their customers is that they have yet to design an automation system that is viable enough in steel mill arrangements. The biggest issue was whether how they could unite the tow hook to automatically release the parking brakes. This issue evolved because the Caterpillar engineers have yet to develop a final design on whether they should set a mechanical or electrical signal to be transferred from the tow hook to release the parking brake. Thus, and to reiterate, we are going to improve or to invent a design that allows the tow hook to stably release the parking brake automatically.



## Chapter 3, Methodology

This design calls for a tow hook system could deactivate the parking brake once a significant amount of force is applied. It is preferable that the current electrical switch is kept as a backup for safety reasons. The switch is connected to the manifold electrically and sends the signal to the solenoid that would begin the accumulation of hydraulic pressure. The hydraulic pressure is then pumped into the actuator and the piston connected to the actuator is shorted to release the brakes. We are going to leave this process untouched and focus on the automated hook design to find a more efficient and safer way to pull the vehicle out of the slag pit. Our design looks to fulfill Caterpillar's mission, which is to be the leader in providing the best value in machines.

There are several parts and steps involved in the towing of the vehicle. The flowchart below shows the process in a way that allows us to better see what parts of the process would be affected when we made changes at different points in the process.



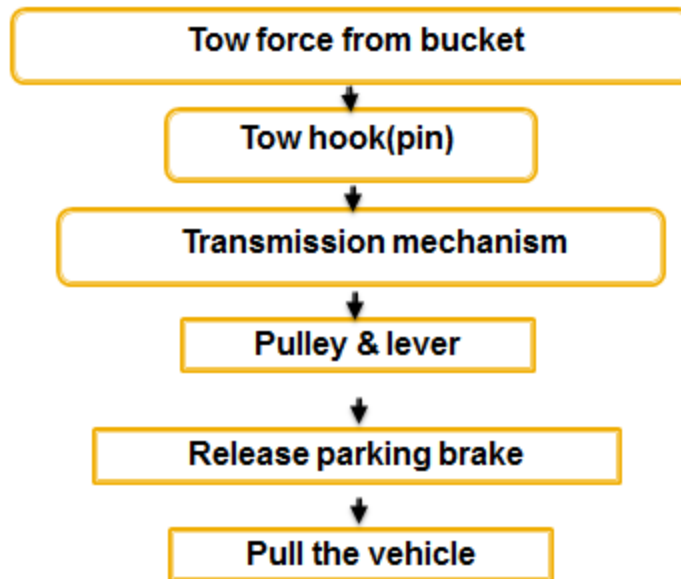

FLOWCHART 3.1: DESIGN WORKING PROCESS

The above flowchart is basically the entire working process of the design we have to implement into the current system. In the current system, there is the separate tow bucket attached to the back side of the disabled vehicle. The electrical switch is pressed when it needs to be used, and this will trigger a electrical signal to engage the hydraulic system. Then the next step is to allow a towing vehicle to attach its own bucket to tow the disabled vehicle. The difference in our methodology to the current methodology of how they currently tow the disabled vehicle is the additional task of creating a tow force activation tow hook design. To obtain this goal, we have to first design a tow hook that must somehow automatically releases the break. In order for this to work the tow hook must have a transmission signal or mechanism to transfer the signal from once the disabled vehicle is being towed with the significant amount of force. This transmission system would then have to make contact to some part of the parking brake release system to actually cause the parking brake to release. So, wherever this design is in contact with, this design would receive the signal to automatically release the brake. Thus, the vehicle could be towed since the parking brake has automatically been released.

## Constraints

As with many other designs that look to improve and replace a current system, there are problems or constraints that needs to be addressed. This design is not an exception and during the design of our parking brake release system we had to work around these restrictions. However, these limitations are not at all bad; these are going to be helpful in determining how efficient our designs really are.

Caterpillar currently designs a tow box and tow pin in the back side of all wheel loaders to enable the task of allowing the wheel loaders to be towed using this pin. In the real world, the biggest issue is that they don't have the right machinery to perform the action of towing to this tow pin. In normal towing methods, a truck attaches its hook to any pipe or pin, and this would allow the truck to reel the machine in. But in steel mill arrangements, they do not have these types of trucks to perform these actions, and even if they do, the heat from the slag pits is extremely high, and it is fatal if a worker were to manually attach this hook to the pin. This is why that many of Caterpillar's clients adopted a custom type of towing. Such types include, but are not limited to: buckets, chain loops, hooks, and steel cable among others. Wheel loaders is provided with many designs to their buckets. In Figure 3.1 below, the bucket is provided with extra teeth at the bottom of the bucket and a barricade of some sort on the top of the bucket. The function of the teeth is to enhance the digging function of the normal flat end buckets. The barrier design on the top of the bucket is said to provide as a blocking function to prevent any materials to be overfilled and bounce back into the engine compartment. Due to these variations in the buckets of the wheel loaders, we need to think about different means of connecting the towing bucket to the tow hook. Because, welding extra hooks or chain loops or other towing

models is very easy. Along with these towing abilities, the teeth of this certain type of bucket could also be used for towing.



FIGURE 3.1: NON-FLAT BUCKET

Other constraints or criteria for our design are that it needs to be easy to assemble, it needs to be strong enough to support the towing force of 157000N and it must allow the vehicle to be easily towed. The design must also use the tow pin already in place by Caterpillar in the rear of the vehicle, in order to standardize the design into all of its vehicles. We were also asked to create a design that is automatically activated. One constraint to this is that we are asked to create a system that is solely mechanical. The reason is that we were told that in this type of design, one single mechanical design is more reliable than having an electric signal sent from the electrical switch.

The purpose of this design is to make it easier for the client to do his job. A complicated design will defeat this purpose and keeping in line with these constraints assures a good quality product.

## Parking Brake

In a normal park brake system for normal automobiles, there is usually a hydraulic system that would act on the parking brake. In addition there is usually an emergency brake that is purely mechanical to that would act on the parking brake (FIGURE 1) on Appendix. In contrast, the parking brake system in wheel loaders is slightly different. There are two different brake systems that act as a failsafe for if the other function fails. In a normal service brake, the service brake valve is depressed to a position that blocks out the hydraulic pressure. As a result, the parking brake is disengaged in this position because of the lack of hydraulic pressure through the service brake valve. Similarly to automobiles, wheel loaders also have a parking brake system. In steel mill machines, the 980h wheel loader is equipped with an extra electrical brake pressure switch. The machine also contains an extra parking brake manifold and solenoid that is connected to this switch electrically. The electrical current signals these two parts to begin charging hydraulic pressures in the accumulators. After this process the hydraulic pressure flows past the parking brake valve, which in turn also seizes all functions performed from the drive-train. The hydraulic pressure fills the actuator and thus decreases its stroke to disengage the parking brake.

## Tow Hook Design

The tow hook design is the most important part of the design, because the function of this hook is to allow the vehicle to be easily towed. Caterpillar wants a design that is simple and easy to use, thus without a design that meets these two qualities the other parts are useless. The requirements for such design are as follows:

- Only contact the tow pin

- Can be towed via chain loop and bucket
- Hard enough to support the towing force of 157000N
- Easy to assemble

The tow hook must perform all of these requirements having in mind that it needs to be as simple as possible. Some brainstorming was done on multiple designs to see which could be the better option.

## Chapter 4, Results

Before starting designing the tow hook, we looked at several tow mechanisms to get ideas on what were the best features the design could have. Each concept was studied closely and we looked at the advantage and disadvantages of each, it did not matter how unreasonable a specific design might be we considered it in hopes of getting something useful out of it.

### Design

The purpose of this design is to allow the vehicle that is towing the disabled vehicle an easier pathway to hook onto the tow hook. Figure 4.1A and 4.1B below, shows two phases to the design: 1.) The tow hook can be seen in a straight up position. This would allow the incoming bucket to head straight into the hook rather than rotating to latch onto the hook. 2.) In the second phase you can see that the incoming bucket applied a force to the spring loaded button. This button would push back the gears or spindles connecting to the tow hook. These spindles would then allow the tow hook to fall straight down onto the incoming bucket.

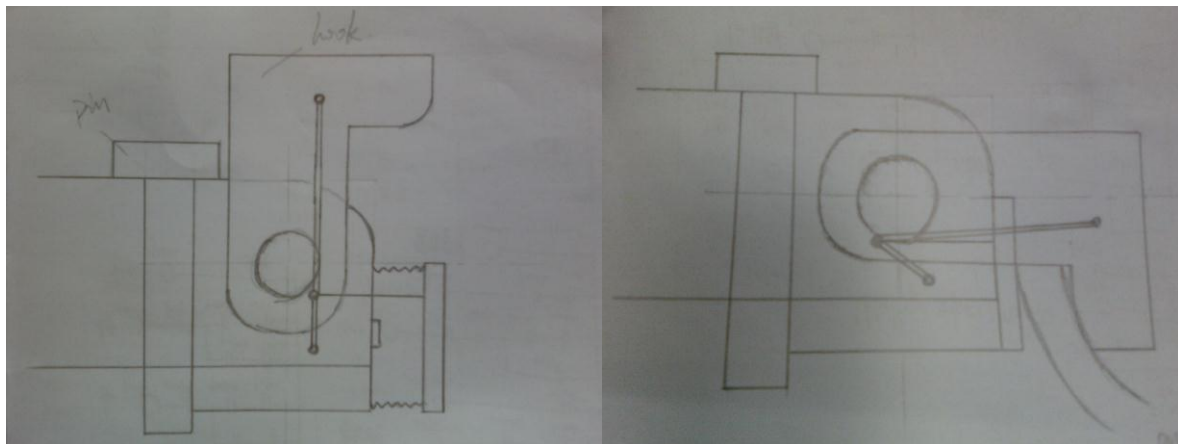

FIGURE 4.1A: DESIGN PHASES

FIGURE 4.2B: DESIGN PHASES

The flaw to this tow hook design is that it is too complex and unnecessary. The extra serviceability of the tow design is not needed due to the fact that it isn't a problem for the incoming bucket to latch onto the tow hook. This extra component may only cause further issues if it fails at one point or another. For instance, the button inclusion is supposedly mechanical. We understand that there has to be an impact load when the incoming towing vehicle is applied. This force at its maximum could be 165 kN. Thus, the gears connecting to the button has to have a restrictor such as an elastic reaction. The materials for such a process are highly expensive. In addition, the tow hook is subject to rotate downwards once the force is applied. From the first image we can see there is a small analogical image of a cantilever beam. This beam has to be connecting or incorporated into the tow hook. From our prior observations, we are not heavily worried about the constant load of 157 kN. The biggest problem is the impact load for this particular design. If this load is applied with that great of a force, the mechanical system of the lever would have a higher chance to force the tow hook to immediately snap downwards.

This second design is meant to provide the company with a different concept of a tow hook. In past designs, every tow hook concept consists of design an additional bucket to act as a tow hook. Caterpillar is always asking for a simpler design to allow the customer easier access to tow the vehicle. This tow hook design may be said to be in a shape of an "ox horn". The concept of this design is to have two hooks welded onto the towing bucket. These hooks on the bucket would then clamp onto the side pins and tow the vehicle. The extra function that you can see in the picture above is that this design could be rotated left and right with the tow pin as the pivot point.

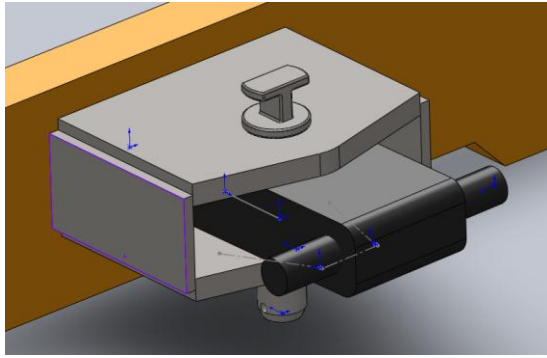

FIGURE 4.2A: "OX HORN DESIGN"

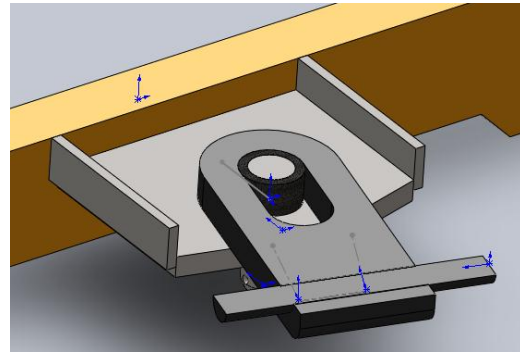

FIGURE 4.2B: INSIDE OF "OX HORN DESIGN"

This concept has a few faults when it comes to towing. One issue is even if welding extra materials like a hook or a cable loop is easy, it is certainly a difficulty to have the hooks stay attached to the two pins of our tow design. This issue is not a really big issue, but it's always a consideration when it comes to the simplicity of towing a vehicle. Another problem is that this design may be lacking having being able to be towed by a bucket. One of our first tasks is to create a design that allows the vehicle to be towed via a chain loop or a bucket. We were shown three different pictures that were developed to show how customers currently tow away their disabled vehicles. They would use only the bucket, or they would weld a hook to the end of the bucket, or they would weld a chain loop to the end of the bucket. In our "ox horn" design, we only sufficed the requirement of having hooks being welded to the bucket to tow the vehicle away. This design has not yet met the requirement of having the disabled vehicle being towed away by a chain loop or the bucket itself. Also, in some performance standards, this design receives a high tow force in two minimal areas. From the images above, you can realize that an incoming tow hook could only latch onto this design with hooks. The hooks would engage the given force of about a constant 157 kN force to this design. Before any analysis, we thought that the two prongs of the tow hook design would be fixed with the entire amount of tow force. But



through further analysis, we understood that we are generating a load in the back side of our design where it is attached to the vehicle's tow pin. In a later analysis, we suggested by using steel alloy, the material will well withstand the live load. But still, this design poses a similar problem of how the impact load could be dealt with.

This second design concept shown below in Figure 4.3 was created in attempt to solely meet the requirement of having any type of hook to tow it. Wheel loaders can perform different functions due to the different shape and structure of the buckets. Normal wheel loaders transport material and earth using flat buckets. In different occasions, buckets with teeth at the bottom edge of the bucket are used to dig into tougher material. We initially created this design so that it would make it easier for this type of bucket with teeth to easily wrap itself into the gap of this tow hook. Another perk for this design is that it is definitely one of the more simple and innovative design. Even though this design maybe simple and easily used with the tow pin, there are also some faults with its capabilities. The usefulness of this design is quite narrow. As I have said before, this design is intended for a bucket with teeth to tow it away. In addition, other point-like hooks that can be welded onto a bucket could be used to attach itself to this tow hook. But, this design is not intended to allow any flat end buckets to tow this hook. This design lacks the ability to allow two major towing capabilities to be enforced. Buckets and chain loops are entirely useless if this tow hook is enforced into the tow pin.

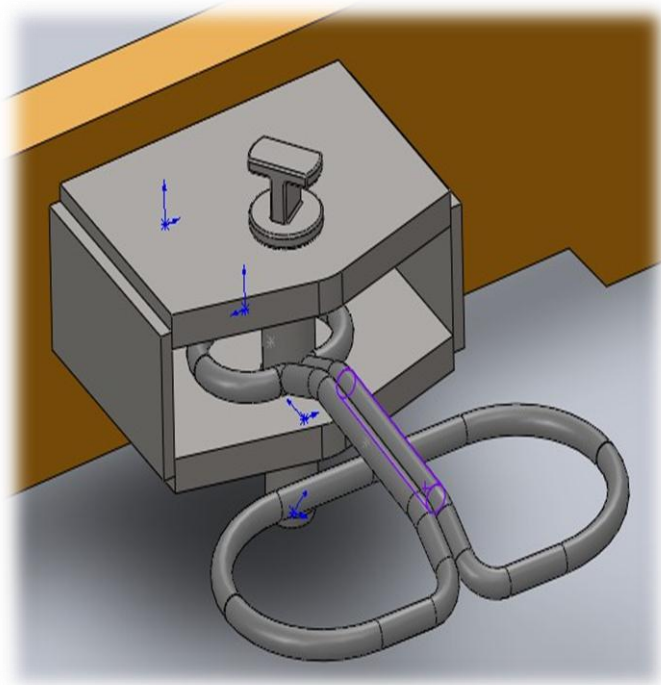
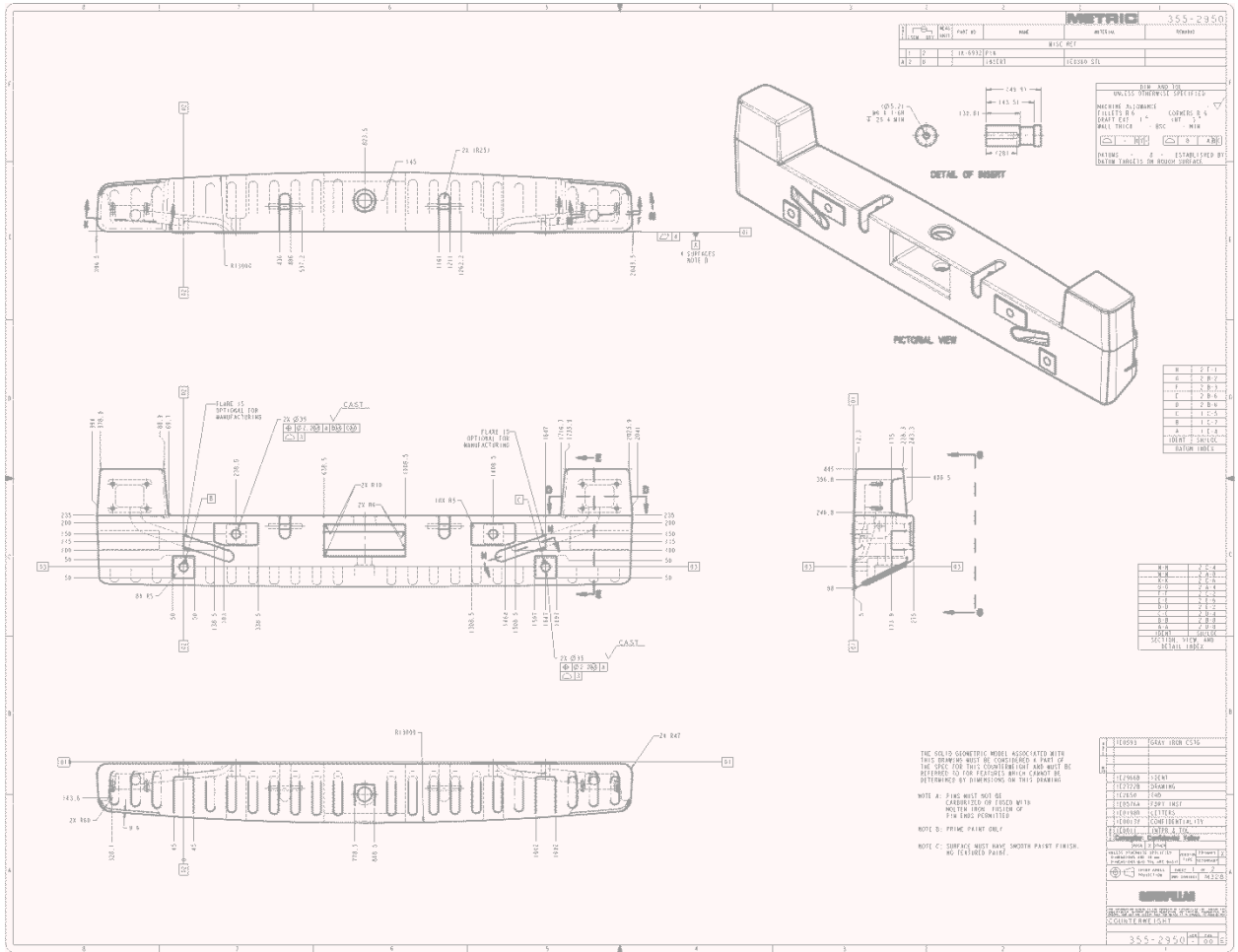

FIGURE 4.3: CHAIN LOOP DESIGN

In a technical point of view, this design showed the most reluctant flaws. Being simple and inventive is very hard when we could remove the aspect of area versus load. We did not process a full analysis for this design because we felt that this type of hook would definitely be a very difficult set up. Performance-wise, this tow hook has very small dimensions.

From the company's 3D drawings of the tow box and the tow pin, the height of the box is 150mm and the width of it is 370mm. The size of the tow pin is irrelevant but when considering the size of our design in figure 4.3, we widely adjusted it from 10-30mm from the bottom when it touches the bottom of the tow box to the top. If we were using steel alloy, as we were suggested to, we would have a complication with permanent plastic deformation in our design. We did not provide any further analysis into this design because we confronted Caterpillar with this incoming issue with stress and strain, and they highly recommended that they could use as much design as possible to create a final outcome.



**FIGURE 4.3.1: DIMENSIONS FOR TOWING DESIGN**

After that, to better analyze the hooks and determine their functionality, we developed a table with three different attributes: Ways to be towed, simplicity and easiness of towing. In our final presentation, we are going to present one final design that incorporates all the best qualities. In addition, we are also going to include our previous designs in our paper and report to the company. Refer to the table below for more information regarding the criterion used for each tow hook.

			
<b>Strength</b>	<b>Moderate</b>	<b>Moderate</b>	<b>Low</b>
<b># Ways to Be Towed</b>	<b>1</b>	<b>1</b>	<b>2</b>
<b>Simplicity</b>	<b>Yes</b>	<b>No</b>	<b>No</b>
<b>Towing Ability</b>	<b>Easy</b>	<b>Hard</b>	<b>Moderate</b>

TABLE 4.1: TOW HOOK COMPARISON

After comparing and talking to our sponsor about our current designs, we discovered that our deliverable should include two to three conceptual tow hook design as well as any mechanical, electrical, or hydraulic signal that is used to release the parking brake. Along with comparing our designs, we compared the tow hook designs that were developed from different project groups from North Carolina State University teamed up with Zhejiang University. Caterpillar provided us with 5 different project group designs. These five teams had 5 weeks to deliver a similar design. These teams also had to design a parking brake release system that is activated by tow force. They were also given an extra constraint that was not presented to us. They had a constraint where they have to activate the parking brake release system without having to eject the vehicle driver from the equipment. Their design concerns also include possibly having a failure with electric actuation with a dead battery. Another concern is that there is a preference for a mechanical actuation of the parking brake release. Overall, one team had an

innovative tow hook design, and another team had a good transmission and actuation design. From Figure 1.3, you can see one team's design for the tow hook. This tow hook enables a bucket to hook onto the corresponding bucket, and a chain loop to be hooked onto the two hooks on the top of the bucket. This bucket suffices the requirement of the different towing options that consumers are looking for, but it also has a few flaws. This bucket design is larger than it is needed to be. A bigger bucket would only mean it would be more complicated to install into the tow box. This design team also adjusted the size of the tow box to accommodate the size of the larger bucket. This design may have met the different towing requirements, but the size is unnecessary. In order to design a more simpler design and reasonable in size, we are going to compare this design with our current designs to come up with a final design to present to caterpillar. Figure 1.4 displays a different tow hook and actuation system. For this design, the tow hook is way too complicated, it uses too many components. These extra parts increase the price and the maintenance, therefore it is not practical and our sponsor project engineer explained that it is not needed to be that sophisticated. For this image, we are going to focus on this team's thought on how they are going to automatically release the parking brake. Even though this actuation system is very vague, you can see that the tow hook is mechanically connected to the parking brake valve. Once tow force is applied to the tow hook, their choice of a mechanical transfer system would transfer the tow force from the hook to the parking brake valve. The parking brake valve would be pulled or pushed accordingly to allow the hydraulic pressure through to the actuator. The added hydraulic pressure would generate the same function as the wheel loader's braking system. The actuator shaft would shorten due to the hydraulic pressure, and the parking brake would be automatically released. One flaw to this concept is how this team decides to turn on the hydraulic pressure. In a normal hydraulic system, the hydraulic pressure has to be emitted from the accumulator charging valve. The charging valve is in charge

of pumping the hydraulic pressure to the actuator. So, if this design team decides to focus on mechanically triggering the parking brake valve, they have to implement a signal to start the hydraulic pressure to pump into the actuator.

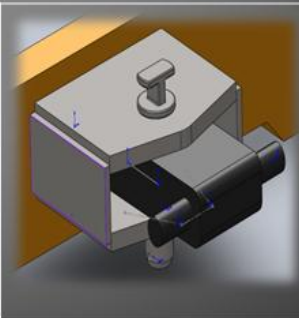
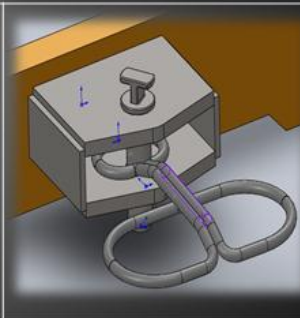
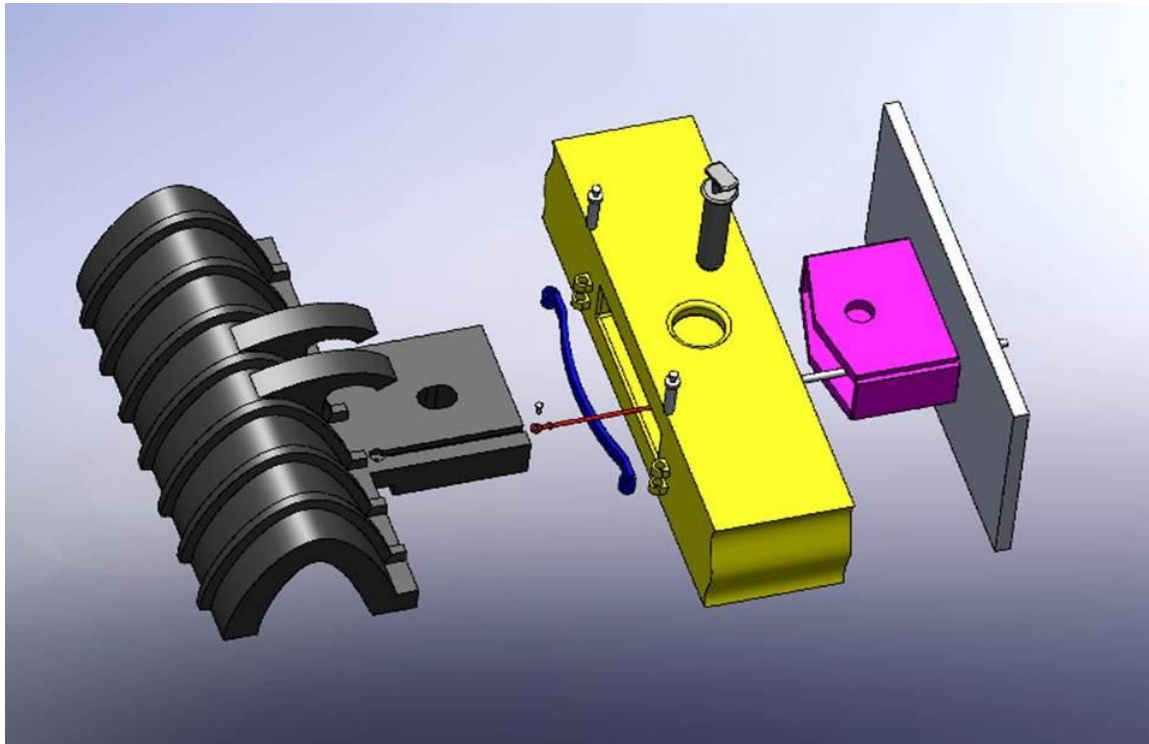

FIGURE 4.4: PREVIOUS DESIGN

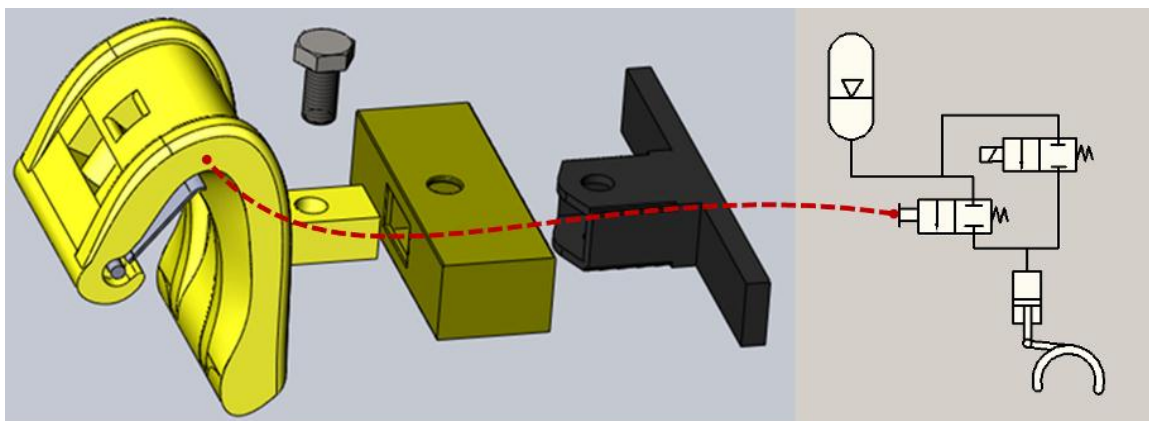

FIGURE 4.5: PREVIOUS DESIGN

After comparing the individual tow hook designs from the past project groups, the design given to us from caterpillar, and our preliminary designs, we developed a final design that we felt matches most requirements as well as being consumer friendly. The customer could use this type of design in cases such as in emergencies. Whether or not there is a equipment malfunction or that the wheel loader is stuck in the slag pit, the consumer or workers would prefer a tow hook that is simple enough to easily tow away the disabled vehicle. In Figure 4.6, you can see our final design that we are proposing to caterpillar. There are many perks to this design due to the fact that we have considered the many flaws that are within all previous designs. There is one addition to this design that was not been taken into consideration in the previous designs; this tow hook design enables the towing vehicle to rotate the hook left or right to wherever it pleases. Other than that, a tow hook should meet as many towing capabilities as possible. In our final design, we provided a top and bottom anchor that would allow a bucket to hook onto the bottom or a chain loop to wrap around the top of the anchor. In addition, we provided a circular gap on the topside of this tow hook. This hole is meant to provide any extra towing options such as using a hook welded on a bucket.

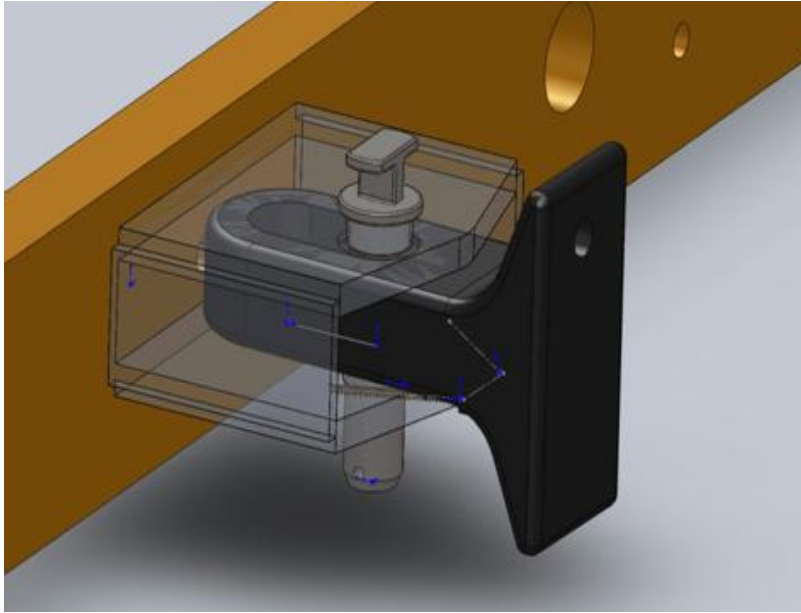

FIGURE 4.6: FINAL TOW HOOK DESIGN

Next Steps:

- Perform Analysis onto our final design
- Perform a cost analysis and performance analysis on whether this design is feasible
- Determine the mechanical linkage that must be included for the actuation of the parking brake.

The figures below were given to us from the caterpillar design team. This is not their final design, and it has yet to be manufactured. But this design as well as previous designs done by North Carolina State University are all concepts that are going to contribute to the final design that caterpillar is looking forward to creating for their clients in steel mills. From Figure 4.7A, a chain loop is welded onto the towing bucket. The process of welding a chain loop to the bucket is extremely simple and easy. This is why consumers are looking for a tow hook design to allow looping to wrap around it for the vehicle to be towed away. From this design, the hook gives a significant amount of space on its rear end to support a loop to fully wrap itself around the back



of the hook. Figure 4.7B focuses on the extended pin that connects the two edges of the tow hook as well as act as a towing option. The second towing option makes use of having a welded hook to get in contact with this extended pin. Consumers do not make use of the tow pin that is incorporated in all the wheel loaders caterpillar builds. A reason is that the tow pin is enclosed by a small tin box that doesn't allow any hook bigger than that size to come between the box and the pin. Because of this one reason, the idea of having an extended pin is generally a better and simpler method for workers to easily use to tow the disabled vehicle away. Figure 4.7C displays the simplest method to tow away a disabled vehicle. Normally, consumers in steel mills would simply attach another bucket to the rear of the vehicle. This bucket would allow another wheel loader to use its own bucket to tow it away. This picture shows how a flat bucket could easily fit into the two hook-like edges. This preliminary design was presented to us to inform us the most preferable ways that the consumers would like to use a tow hook to tow a disabled vehicle.

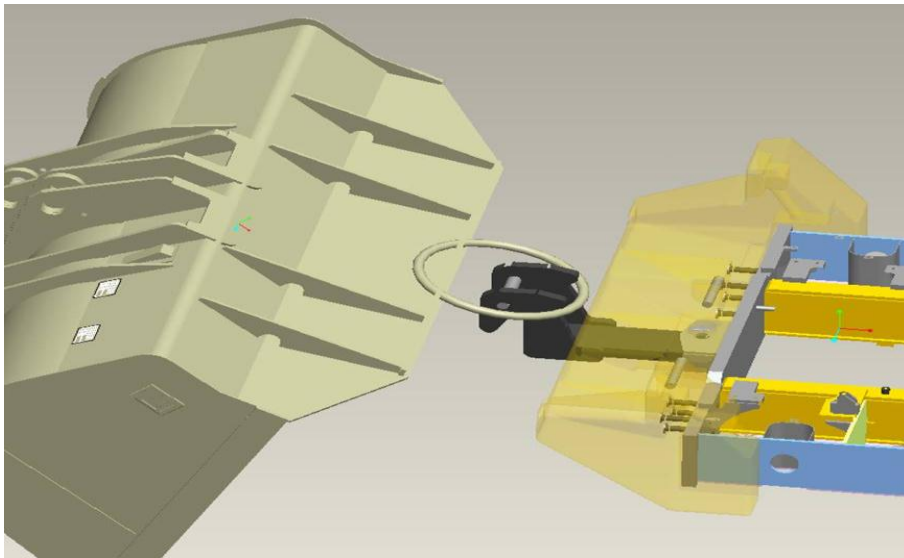

FIGURE 4.7A: PREVIOUS HOOK DESIGN

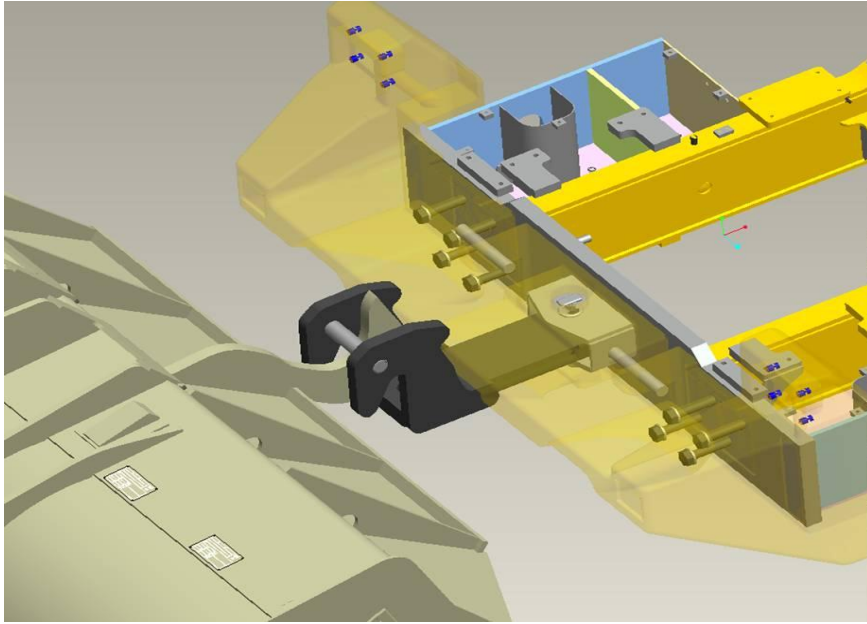

FIGURE 4.7B: PREVIOUS HOOK DESIGN

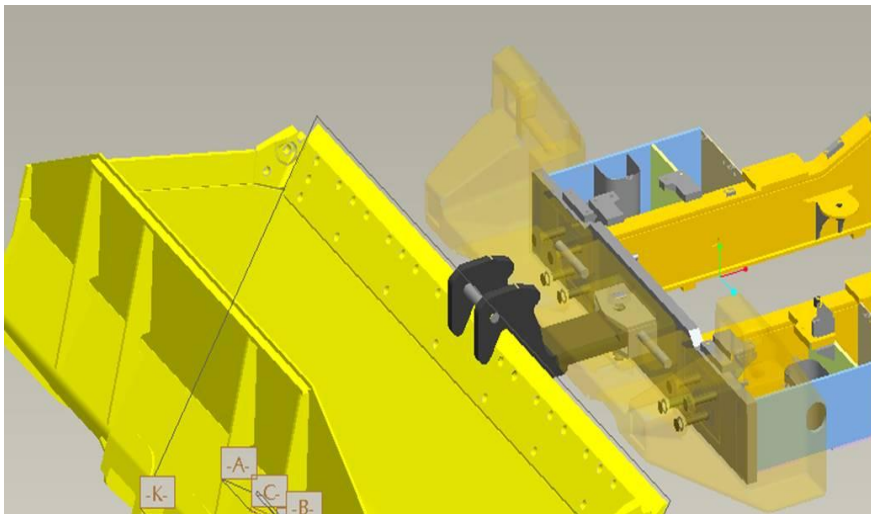

FIGURE 4.7C: PREVIOUS HOOK DESIGN

These images are definitely a good resource to compare our final design. Because we have no standard of how our design should end up, we can safely assume that as long as our design could be towed in those three significant methods, then it could be a considerable design.

## Transmission Mechanism Design

Another part of the design is the transmission mechanism. There are three main tasks that we expect this design to perform and these requirements involve a mechanical transmission function, to decrease the force from the tow hook within this system and transfer the force from the hook to the pulley system.

There were different types of transmission mechanisms that were considered for the design. One included an electrical sensor that could send a signal to the electrical system of the vehicle to release the parking brake. However, due to the high temperatures in steel mills, the complexity of design and the high price tag for such mechanisms did not make sense. Our design needed to be simple and efficient and this type of mechanism did not fulfill any of this. Therefore, we opted for a fully mechanical transmission that was economical, could be easily fixed and could withstand the high temperatures of the still mill.

To reiterate, we already know that there has been a previous design or idea for what transmission system that could be possible. We know that a previous project intends to implement the use of the parking brake valve to allow the hydraulic fluid to flow through to the actuator to release the brake. This transmission system does not idolize the flaws that can come from it. One issue that we did not uncover from looking at this idea is how they are going to transfer the force from the tow hook to this parking brake valve. From Figures 4.4 and 4.5, there are only images of the tow hook being able to connect to the parking brake valve. We do not know what kind of material is used to connect these two parts, and we do not know how they are going to transfer such a large amount of tow force to the parking brake valve.

At first, we focused most of our attention to the tow hook and how it could automatically release the brakes. Once we figured out there was a previous concept on what transmission system was being used, we wanted to be more innovative. We can currently identify three main locations that are used as an actuation to automatically release the brake. The current method is to manually engage the switch. In this manual arrangement there is no need for a transmission design because there is no need to transfer the tow force to release the brakes. A transmission design is desirable because it enables the whole process of releasing the brake to be automated. Other than understanding the need for a transmission design, the focus should be on the location of our design to perform the necessary actions to release the brakes.

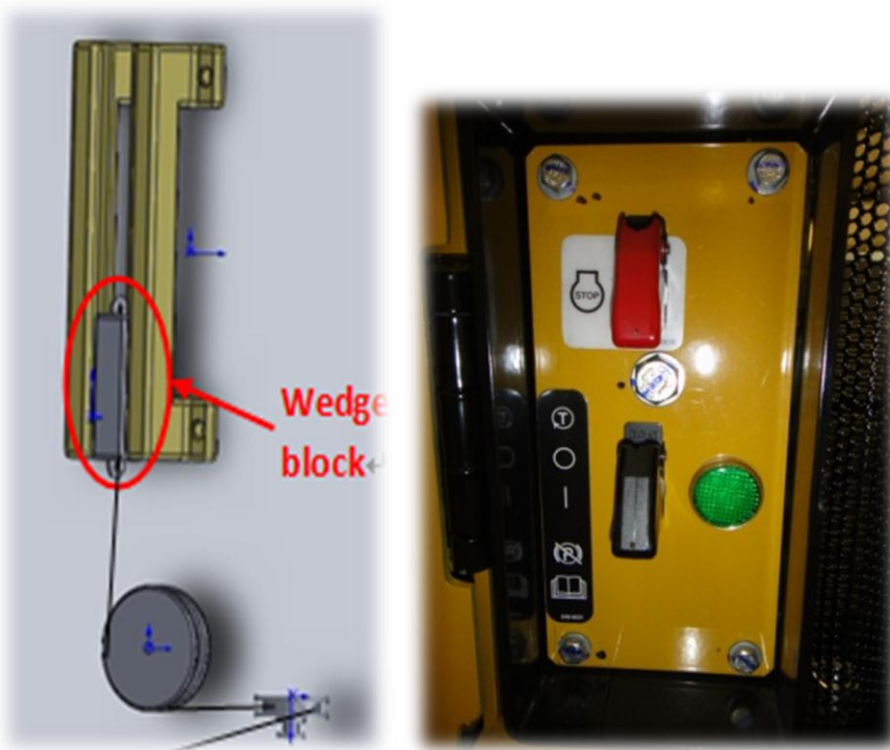

FIGURE 4.8 & FIGURE 4.9: SIGNAL PROCESS

When we were first introduced to this project, it was recommended to us to keep the electrical switch as a backup for emergency uses. Our group realized that if we were to create

and automated parking brake release system, we could maybe create a mechanical signal that could automatically contact the electrical switch once the tow force was applied. In the figure above, we have provided a rough 3d model of what we first decided to bolt onto the electrical switch. This design is solely mechanical. In this assembly, there are two rails that hold a wedge block in place. This block is connected to the tow hook by a steel cable. This cable runs through a pulley system that is meant to reduce the force from the tow hook to a considerably small amount that is also enough to pull the block down railings. In the end, after discussing this idea with Scott Panse (CAT Engineer), we concluded that this design contained too many steps to release the parking brake. We finalized that customers are more likely to use a design that could mechanically release the brake. Figures 4.8 and 4.9 this process is shown.

Taking our final tow hook design into consideration, we decided to transfer the tow force from the tow hook through a steel cable all the way through to our final actuation design. Our final design for the tow hook is mounted within the tow box, and the tow pin is located within an oval gap within our tow hook. For our design to automatically release the brakes, we decided to incorporate only a steel cable to mechanically affect the actuation system to release the brakes. To make it simpler, I'm going to describe the simple process from the towing vehicle to the steel cable. So, once tow force is applied, our tow hook design would be pulled into the outmost position until the tow pin stops the tow hook from moving. At this location, it is meant to withstand a force of 157kN. The estimated impact and tow force is expected to be 165kN, and subtracting these two number will leave a remaining force of 8kN. This 8kN is meant to provide the right amount of force to release the parking brake as it would for the parking brake actuator to release the brake.

## **Actuation Design**

Before finalizing our actuation design, we first compared the three different actuation designs that we already had.



			
<b># Signals (Mechanical, Electrical, Hydraulic)</b>	3	2	2
<b>Dependability</b>	Low	Moderate	Moderate
<b>Automated</b>	Yes	Yes	No

TABLE 4.2: ACTUATION DESIGN COMPARISON

The first design is the electrical switch. A few facts for this actuation design are that it must be manually engaged, and it contains the use of an electrical signal to trigger the hydraulic pressure to release the brakes. The second design is the use of the parking brake valve that makes uses of a mechanical signal from the tow force to trigger the hydraulic pressure to release the brakes. The last design is our preliminary design of having a mechanical system where a wedge block would automatically trigger the electrical switch once the tow force is applied.

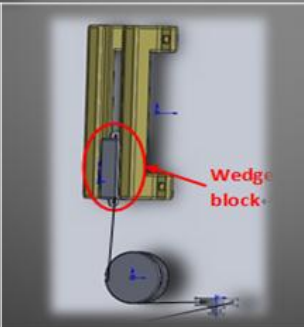
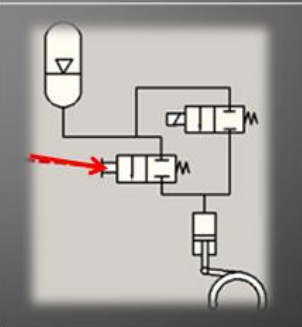
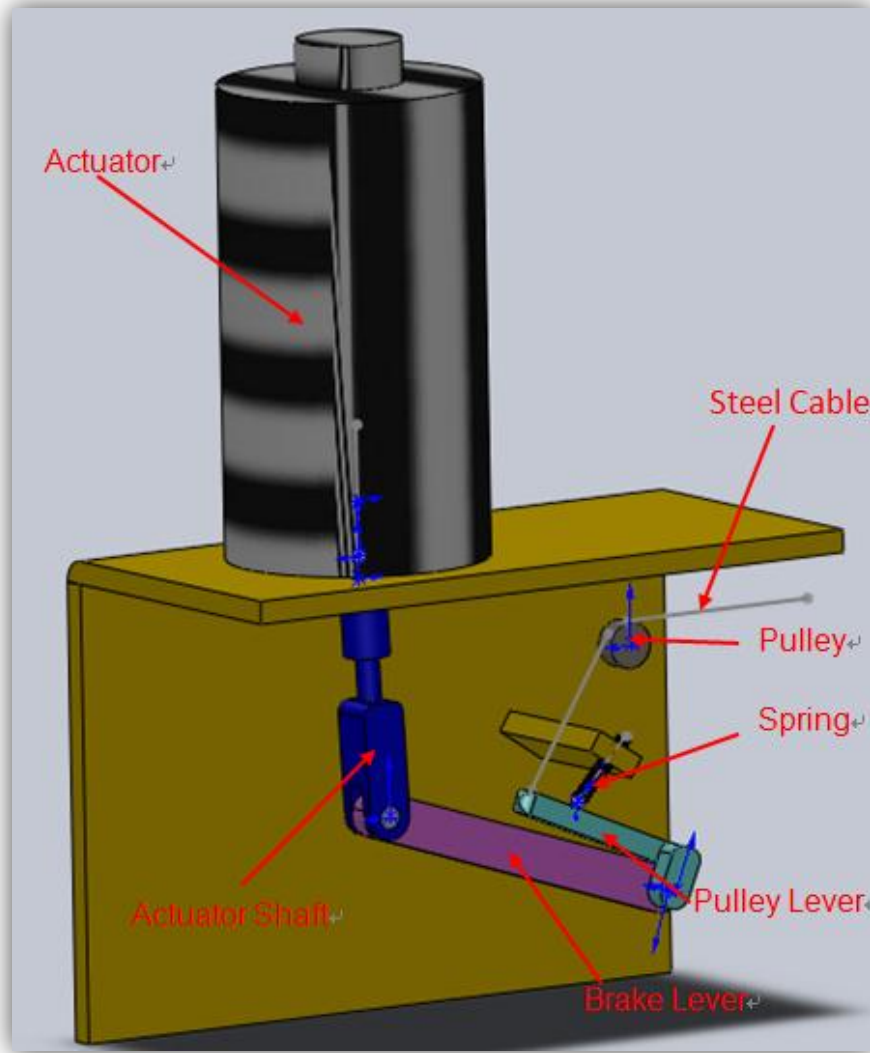

FIGURE 4.10: COMPLETE ACTUATION DESIGN

The image above is our 3D model for our final actuation design. All of the components are already listed, aside from some different terminology. For example, the brake lever is actually connected to the camshaft by the lever screw. At the position where you see the pulley lever intersecting the brake lever, a lever screw connects these two components with the camshaft to directly affect the brake drum.



The entire working process of our final and complete design is pretty straightforward. Once tow force is applied to our tow hook design, the tow pin would stop and withstand the 157kN of force. The leftover force of 8kN is going to be used to pull on our pulley lever. The pulley lever is meant to create the same action as the brake lever. This design is feasible because of the fact that our mechanical design can provide the same motion to release the brake as it would with the hydraulic system. In the pulley design, the cable is connected to the transmission mechanism and the spring is always compressed. The purpose for this design is to let the parking brake be released independently without affecting the hydraulic pressure of the actuator.

The figure below shows the complete design of the automated tow hook system. This figure shows how the pieces go together and the working process when activated.

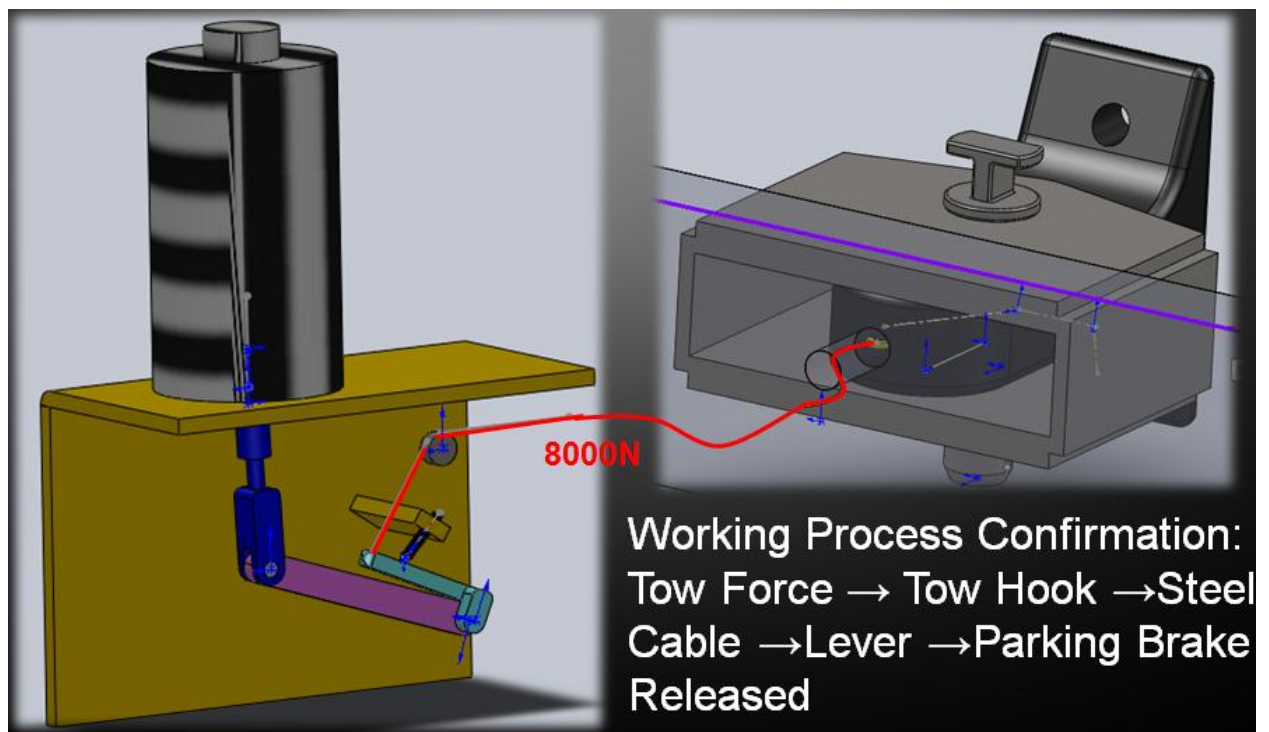

FIGURE 4.11: COMPLETED DESIGN

## Material Selection



Material selection was an important part of our project. Ideally, we wanted to obtain a material that was of high quality and cost efficient. A high quality material means that it will be able to support the stress and strains loads caused by the towing force. A cost efficient material is one that meets the strength requirements we need at an affordable price. Before starting any material selection the stress and strain forces were analyzed to observe where the majority of the force was being applied to and the magnitude of these forces.

Once we got our strain/stress results we used the CES Edupack software and other resources available to us over the internet to determine which material to use. We looked at different sources for material selection and compared them across the board. The tables used are shown in the appendix section for reference.

The criterion used for the materials selected was simple, we chose materials that would meet the required strength to perform the work, its functionality and then we did price comparison to choose the least expensive. For example, in the selection of the steel cable for the pulley design the requirements for such cable was that it needed to handle a force of 8KN that was being directed to the pulley. We had limited options on the type of materials we were to use as per Caterpillar's decision and the harsh environment in which it was going to be use, so we decided to use a steel cable. If you take a look at Table 3.1 in the appendix, all of the cables could easily handle this force. A 6mm nominal diameter steel cable had a breaking load of 19KN, more than twice what was required, it was also the one who weighed less and it was also the cheapest.

## **Factor of Safety**

The factor of safety describes the capacity of a structure of safely sustaining loads or forces. Most structures are built considerably stronger than needed for everyday use to allow for unforeseen situations that may put the structure at risk of defaulting due to unexpected loads, degradation among others. There are two main uses for the factor of safety. One is the ratio of structural capacity to the actual applied load, this shows the reliability of the structure. The other use comes from a value imposed by construction standards, law, contractual agreement or a custom value to which it must conform.

A factor of safety depends on the engineering code for the material that is involved. Whether the process concerns mechanical or for other construction processes, the table shown in the appendix, Table 3.2 indicates some typical values that are used as a design factor to develop the final design load and this table was used table to determine the proper factor of safety we should use for our design. For this particular project we could not find any evidence of standard that we should comply to when designing our hook. The selection of the factor of safety for our project came through observing similar structures and looking at what type of standards they had. Then, to our discretion we selected the value we thought was proper considering the function that the hook would have and performed a basic calculation dividing the allowable stress by the safety factor we had chosen.

## **Cost Analysis**

Most companies would have their own categorization for the materials they use. Caterpillar uses a particular gray cast iron to develop their parts such as the counterweight in the backside of the 980H wheel loader. Other than cast iron, Caterpillar uses alloy steel for the specific tow pin that they build on all wheel loaders. Although we weren't given more material of

other parts, we were told to assume that most parts are made with those two types of material. The table shows a list of 4 materials that are the closest to match the criteria and percent composition of the material that Caterpillar showed us. This list of material was gathered from CES Edupack. This software is meant to serve for material analysis. Although the software does not contain specific material due to various works that is performed, or any addition of other materials, it provides the most common elements. After completing our final design, we ended up deciding on using steel alloy to create our tow hook design and our pulley design. After analyzing our tow hook design and pulley design, we multiplied the volume of both models with the density and then multiplied that number with the price to get the final price of 32.25 USD.

## Chapter 5, Conclusion

To conclude, this project has been an amazing experience both professionally and personally. We got to experience working with some great engineers at Caterpillar that helped us out in answering our questions and guiding us through the project. It was real eye opening going through with this project because we did not realize all the factors that need to be considered when designing a structure. Also, we learned about the many challenges many companies face today with globalization, how they have to adapt to different rules/regulations based on the country they are in, working with people from different background and finding common ground with them as on how to do anything. We learned that there is just not one way of doing things, that there are many ways to arrive to the same destination and when something is different from what you are doing it does not necessarily mean is wrong. Overall it was a wonderful experience and I would recommend any student that has an open mind and willing to do something different to experience this project.

## Recommendations

For future recommendations, if we were to continue our own design, we would definitely have to figure out what flaws that could be enveloped in our current design. We may have to further understand the mechanical properties that could be present in real life situations. For instance, we may not be dealing with specifically 157kN for the force that we were given for the breakout force. We were not given the opportunity to actually develop our design and test the actual efficiency of our system. Designs and concepts are very helpful in creating a final project

design, but actually having a real model of our system is definitely an advantage of finding out flaws that numbers could not predict.

Other than having a tow hook design that has to be mounted with the tow pin that is already in place by Caterpillar, there could be something done to the vehicle that does the towing. For example, customers currently use other wheel loader buckets to tow the disabled vehicle. We may provide some kind of tow hook that could be mounted onto the wheel loader bucket. In order to allow for the brake to be automatically released, there could be a sensor built into the tow pin. A sensor that is built with the tow pin would provide a more secure method of releasing the brakes.

A third option that we could take when continuing this type of project could be to reposition the electrical switch. Currently, we already know the electrical switch have to be manually engaged. If the circuit were to be attached to the tow box or with any component during the towing process, then once tow force is applied, it would trigger the same signal as the electrical switch.

As far as the project itself, although it was not an orthodox civil engineering project, we found ourselves applying many of the things we have learned in our classes to the project; after all it is still engineering and designing a structure. We do hope that the school can expand this project centers to offer opportunities to students from different majors to come and experience China.

## Chapter 6, References

1. "A Timeline of Projects Completed around the World 1883 - 2011." *Caterpillar, "Our History*. N.p., n.d. Web. 19 Feb. 2013. <<http://www.caterpillar.com/company/history>>.
2. Table, Safety Factor <[http://engr.bd.psu.edu/rxm61/213/problems/factor\\_of\\_safety.pdf](http://engr.bd.psu.edu/rxm61/213/problems/factor_of_safety.pdf)>
3. Unknown. "Factor of Safety." *Wikipedia*. Wikimedia Foundation, 02 Aug. 2013. Web. 19 Feb. 2013. <[http://en.wikipedia.org/wiki/Factor\\_of\\_safety](http://en.wikipedia.org/wiki/Factor_of_safety)>
4. 19th Century Tractor - <[www.farmguide.org](http://www.farmguide.org)>
5. "CATERPILLAR LOCATIONS TOTAL MORE THAN 500 WORLDWIDE." *Caterpillar Global Footprint*. N.p., n.d. Web. 19 Feb. 2013. <<http://www.caterpillar.com/company/global-footprint>>.
6. "Untitled." *Pastebin*. N.p., n.d. Web. 19 Feb. 2013. <<http://pastebin.com/PMT1sZDv>>.

