

Project Number: GLPC-RLN-10-11

**Product Load Mechanism**

A Major Qualifying Project Report

submitted to the Faculty

of the

WORCESTER POLYTECHNIC INSTITUTE

in partial fulfillment of the requirements for the

Degree of Bachelor of Science

by

---

Megan Faulkner

---

Laura Friedman

---

Stephen Galucki

---

John Moakley

Date: March 4, 2011

Approved:

---

Professor Robert L. Norton, Advisor

---

Professor Diana A. Lados, Advisor

## **Acknowledgements**

The MQP team would like to thank the following people for their assistance and support throughout the course of this project.

- Professor Robert L. Norton
- Professor Diana A. Lados
- Charlie Gillis
- Krystyna Gielo-Perczak
- Neil Whitehouse
- Jeff Gorges
- Torbjorn Bergstrom
- Washburn Shops Staff at WPI
- Higgins Laboratories Staff at WPI

## **Abstract**

The goal of this project was to design a better way of transporting an extruded foam product from a reel to a load head on an assembly. The problem was broken into five parts: splitting, indexing, cutting, merging and inserting. The splitting and cutting steps were already solved by the sponsor, so the team created solutions for the remaining three processes. They were solved in two subassemblies: a grabbing and indexing mechanism that provided movement to the product on a track, and a shuttle mechanism that merged the two lines of product and inserted them into the load head.

## **Executive Summary**

The goal of this project was to design a better way of transporting an extruded foam product from a reel to a load head on an assembly. The sponsor's current method of moving the product jams frequently causing large amounts of machine down-time.

## **Material Testing**

Material testing was conducted to obtain the compressive and tensile forces that the product could be subjected to. The product's tensile properties were examined using an Instron tensile testing machine, to determine ultimate tensile strength, Young's Modulus, yield strength, and breaking force. This data was then used in the design process.

## **Design**

The product is initially on a reel as a two-sided foam extrusion. It must be pulled off the reel and indexed through a splitter where the two sides of the foam extrusion will be split down the middle into two product streams. Next it will be advanced to a cutting station where it will be cut to length. The product is merged and inserted into the load jaws as two separate parts. The primary goal of the project was to design the indexing, merging and loading mechanisms. The sponsor indicated that the current de-reeler, splitter and cutter were satisfactory and did not need to be re-designed. This left the indexing and grabbing and merging to be designed.

## **Indexing**

The indexer needed to pull the product through the splitter and into the cutting station. To accomplish this, we designed several different mechanisms before finalizing a design. The final design uses a Festo toothed belt that is axially controlled by two servomotors to create the indexing motion.

## **Grabbing**

The product needed to be grabbed during the indexing process. The specifications required that the product be grabbed in a way that would not damage it or allow slipping. Different concepts were designed using mechanical and pneumatic grabbers. The final design uses a Festo piston to control a plate that closes on the two streams of product when they are to be indexed forward.

## **Merging**

Both of the streams of cut product needed to be merged into one stream and placed in the load jaw. After several iterations, one device was designed to satisfy both the merging and loading needs. The shuttle mechanism designed uses solenoids to alternate a shuttle between the two tracks of product. As a vacuum pulls a cut piece of the product into one side of the shuttle, it uses a jet of air to push the previously acquired strip out of the shuttle and into the load jaw.

## **Final Overall Assembly**

The final assembly, shown in Figure 1, maintains full control of the product during the entire process. A track was created to guide the product between stations, and mounting brackets

were designed to join all of the stations to the existing assembly line and each other.

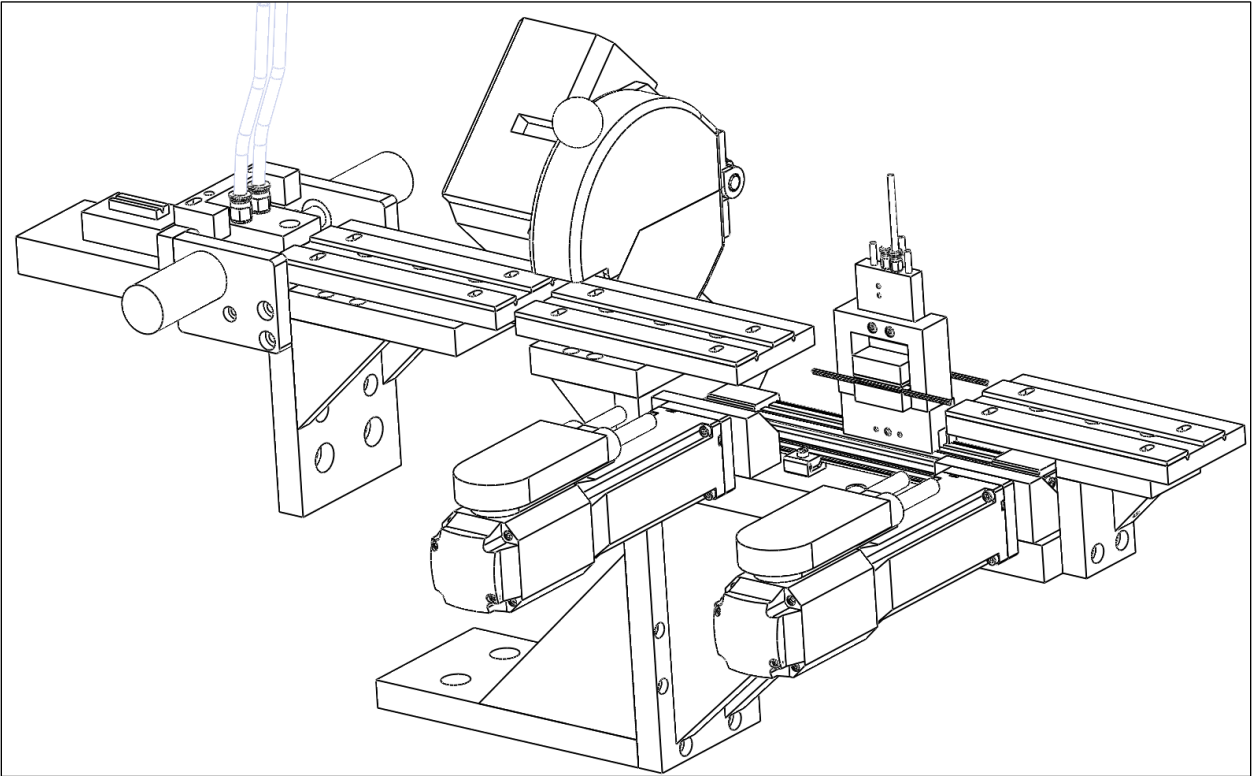

Figure 1: Final Assembly

## Table of Contents

Acknowledgements .....	1
Abstract .....	2
Executive Summary .....	3
Material Testing .....	3
Design .....	3
Indexing .....	3
Grabbing .....	4
Merging .....	4
Final Overall Assembly .....	4
List of Figures .....	8
List of Tables .....	11
Introduction.....	12
1. Background Research .....	16
1.1 Indexing .....	16
1.2 Grabbing .....	19
1.3 Merging.....	21
1.4 Material Properties.....	24
2. Preliminary Analysis.....	26
2.1 Sponsor Feedback.....	26

2.2 System Analysis Using CAD.....	27
2.3 Material Testing.....	29
2.3.1 Introduction.....	29
2.3.2 Methodology.....	30
2.3.3 Results.....	31
3. Design.....	34
3.1 Indexing Design.....	34
3.1.1 Early Design Iterations.....	34
3.1.2 Linear Slide.....	37
3.2 Grabbing Design.....	40
3.2.1 Spring Gripper.....	40
3.2.2 Hug Feeder.....	41
3.2.3 Mechanical Grabber.....	42
3.2.4 Piston Grabber.....	47
3.2.5 Final Grabbing Design.....	51
3.2.6 Piston Prototyping and Testing.....	59
3.3 Shuttle and Track Development.....	65
3.3.1 Air-Jet Injection.....	65
3.3.2 Tommy Gun Concept.....	67
4. Results.....	82



5. Conclusions and Recommendations .....	84
Appendix A: Indexing and Grabbing Mechanism Drawings .....	85
Appendix B: Merging Mechanism Drawings.....	91
Appendix C: Track and Mounting Drawings.....	98
Appendix D: Product Testing Results.....	111
Appendix E: Product Data Sheets.....	117
7. Bibliography .....	120

## List of Figures

Figure 1: Final Assembly.....	5
Figure 2: Block Diagram of Full Design .....	14
Figure 3: Timing Belt.....	16
Figure 4: Parallel Shaft Drive and Index Machine .....	17
Figure 5: Geneva Mechanism .....	18
Figure 6: Slider Crank Mechanism.....	18
Figure 7: Festo Toothed Belt Axes Drive .....	19
Figure 8: Gripper Mechanism.....	20
Figure 9: Piston-Cylinder Schematic .....	21
Figure 10: Lane Merger Apparatus.....	23
Figure 11: Apparatus for Combining Articles from Plural Lanes into a Single Lane .....	24
Figure 12: Compiled Data Stress-Strain Curve .....	31
Figure 13: Stress-Strain Curve Compiled Data .....	32

Figure 14: The Initial Design of the Eccentric Crank.....	35
Figure 15: The Rotated Eccentric Crank .....	36
Figure 16: Indexer-Grabber Assembly .....	37
Figure 17: Complete Indexing Assembly .....	38
Figure 18: The Velocity Profile of the Servo Motor.....	39
Figure 19: The Custom Motor Brackets .....	40
Figure 20: Spring Gripper .....	41
Figure 21: Hug Feeder .....	42
Figure 22: Mechanical Grabber .....	43
Figure 23: Updated Mechanical Grabber.....	44
Figure 24: Back of Updated Mechanical Grabber .....	45
Figure 25: Tab.....	46
Figure 26: Piston Grabber.....	47
Figure 27: Piston Grabber on Linear Guide.....	49
Figure 28: Smaller Piston Assembly.....	50
Figure 29: Final Piston Grabbing Design .....	51
Figure 30: Piston Assembly .....	52
Figure 31: Back View of Piston Housing Mounting .....	53
Figure 32: Piston Support .....	54
Figure 33: Piston Block in Closed and Open Position.....	55
Figure 34: Side (left) and head on (right) view of plate mounting .....	56
Figure 35: Base .....	57
Figure 36: Front View of Mounting Base.....	58

Figure 37: Overall Piston Assembly with Linear Slide .....	59
Figure 38: CAD Prototype and Physical Model .....	60
Figure 39: Piston Grabber Test Rig .....	62
Figure 40: Loaded Piston Grabber .....	63
Figure 41: Air-jet Injection Concept.....	66
Figure 42: Tommy Gun Concept .....	67
Figure 43: Shuttle Assembly Top View .....	69
Figure 44: Ledex Solenoid Force and Speed Vs. Stroke Charts.....	70
Figure 45: Solenoid Test Assembly .....	73
Figure 46: Acceleration of Test Shuttle Mass.....	74
Figure 47: Alternate Shuttle Track Iteration .....	76
Figure 48: Model of Alternate Track Design.....	77
Figure 49: Alternate Track Design Manufactured Parts .....	77
Figure 50: Track Profile (dimensions are in mm).....	78
Figure 51: Top Section of Track in Open Position .....	80
Figure 52: Top Section of Track in Closed Position.....	80
Figure 53: Overall Assembly .....	82
Figure 54: Sample 2-Load versus Time.....	111
Figure 55: Sample 3-Load versus Time.....	111
Figure 56: Sample 4-Load versus Time.....	111
Figure 57: Sample 5-Load versus Time.....	112
Figure 58: Sample 6-Load versus Time.....	112
Figure 59: Sample 7-Load versus Time.....	112

Figure 60: Sample 8-Load versus Time.....	113
Figure 61: Sample 2-Load versus Extension .....	113
Figure 62: Sample 3-Load versus Extension .....	114
Figure 63: Sample 4-Load versus Extension .....	114
Figure 64: Sample 5-Load versus Extension .....	115
Figure 65: Sample 6-Load versus Extension .....	115
Figure 66: Sample 7-Load versus Extension .....	116
Figure 67: Sample 8-Load versus Extension .....	116
Figure 68: VXB Linear Bearings Specifications .....	117
Figure 69: Ledex Solenoid Specifications .....	119

## **List of Tables**

Table 1: Material Properties.....	33
Table 2: Rubber Testing Results.....	65
Table 3: Lee Spring's Wave Spring Specifications.....	117
Table 4: Ledex Solenoid Duty Cycle.....	118

## **Introduction**

Manufacturing large quantities of parts requires efficient, automated machines. These automated assembly machines are responsible for creating products for today's consumers. The desired effects of these procedures are minimizing production costs, increasing the speed of assembly, and maximizing the quality of the product.

Our sponsor company presents us with the challenge of designing a machine to handle a material that is inserted into several of their products. The raw material is a foam extrusion which needs to be pulled off a reel, split in half, cut to length, and inserted into the product. The material must be grabbed, indexed, cut to the proper length, and have the two split lines of material merged onto one line.

The material is brittle and is easily deformed under minimal pressure. One task is to create a grabbing device that does not change the profile of the extrusion or damage it. Grabbing the material can be done in different ways, such as mechanically driven devices or pneumatics. The desired goal is to grab the material with the minimum force to pull it while retaining its original shape.

Indexing devices are used in a wide variety of applications to move stock in increments. Their purpose is to move the stock in the assembly line by a specified amount. There are many devices used to achieve indexing, such as four-bar mechanisms, gears, cam and follower systems, linear slides, and rotary devices. The purpose of the indexer in this project is to simultaneously work with the grabber device to pull the product from its reel and move it to the cutting station. Our task is to find the simplest mode of indexing the raw stock. The cutting station is simply a blade that shears the product to the proper length. The sponsor provided the cutting device to the group, as there was no need for redesign.

The two separate lines of product produced from the splitting function must be merged into a single line. This requires a merging process for the product. Additionally, the two lines of product must be constrained within a track to guide them through the processes. This requires a custom track design fit to the product.

The problem as presented by the sponsor was to create a new method of moving a product from a reel on which it is stored upon to a load head on an assembly line. In order to accomplish this, the problem was divided into several parts. The product itself is a foam extrusion which, after it is manufactured, is stored on a large reel. The profile that is manufactured must be split in two and cut to length before it is ready to be inserted into the load head. The splitting of the product results in two lines that must be joined and inserted into the same load head. This requires a merging step that also had to be completed. Finally, in order to transport the product between these steps, an indexing process also had to be introduced. The order of these steps would determine the design of our assembly and therefore had to be determined before the design process began.

There was a balance between several of the steps that had to be considered to optimize the order of sub-assemblies in the overall assembly. The indexing mechanism must be able to pull the slack of the product off the reel and push it forward from there. In order to be able to pull the product, this step had to occur before the cutting. However, the cut product may still be indexed using the same device if the products push each other end to end. Therefore, the cutting assembly is placed after the indexing mechanism.

The indexing and merging steps also had to be balanced to create a working assembly. If the two lines resulting from the splitting are joined into the same line, the resulting line will move at twice the pace of the dual lines. Although the merging step has to occur after the

indexing and cutting steps, this is an advantage that permits twice as much time for the indexing, splitting, and cutting steps as the assembly line indexes. To merge the two lines, however, the singular line must alternate accepting the product between the dual lines. A mechanism must be created to fulfill this requirement.

An order of functions was decided upon considering these aspects. First, the indexing mechanism unreels and pulls the product through the splitting process. According to the sponsor, the current splitting mechanism is adequate and does not need to be redesigned. Next, a slicing machine cuts the product to length. This slicer, as with the splitter, does not need a redesign and is provided by the sponsor. Finally, the products will be merged and inserted into the load head.

Figure 2 shows a block diagram of the overall design.

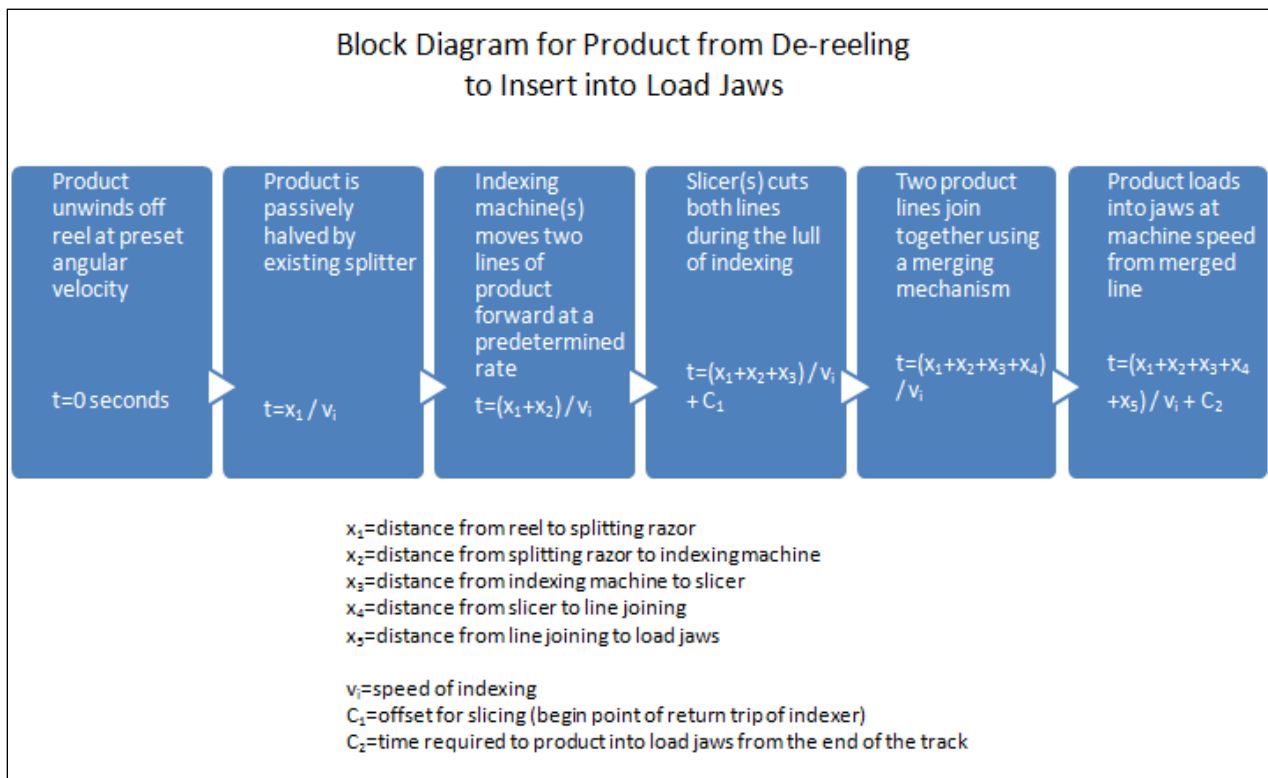

Figure 2: Block Diagram of Full Design

To achieve this, initial background research and analysis were done. We researched machines with similar functions in order to create several iterations before achieving a final design. We were sent a CAD model of the load head mechanism that our design would interface with. We reverse engineered the model to understand its functionality. Material testing and analysis was also done to observe how the material behaves and to obtain values for analytical calculations.



# 1. Background Research

## 1.1 Indexing

A facet of the necessary background research was to investigate existing indexing machines and see if there was one suitable for the task at hand.

One of the first areas investigated was that of indexing belt drives. A belt can carry cut pieces of the product between the cutter and the load mechanism. To precisely control the product throughout the entire process, timing belt or chain systems could be used. A timing belt (shown in Figure 3) is a belt with a toothed inside edge which allows for precise positioning. A timing chain is a series of links that has gearing notches on its underside to allow for precise control of its positioning in the same fashion as a timing belt. Problems found with timing belts or chains were that the product would need to be tightly controlled and contained while on it, which could be difficult considering the amount of vibration that may be found on a timing belt or chain during operation. The level of complexity required in creating a custom timing chain or belt was also outside of the scope of this project.



Figure 3: Timing Belt

Investigating existing patents was an important part of this project. There are many different types of indexing motions available, and it was important to see if an existing one could

be modified to suit our needs. The device of Figure 4 is patent number 5176036 titled “Parallel Shaft Drive and Index Machine” created by William O. Harris, and uses a cam to index a rotary drive. This could work if an appropriate clamping motion on the product could be found. The main problem is that it only moves in one direction and it would be difficult to get a uniform clamping force to stay on the product for the total distance that it needs to move.

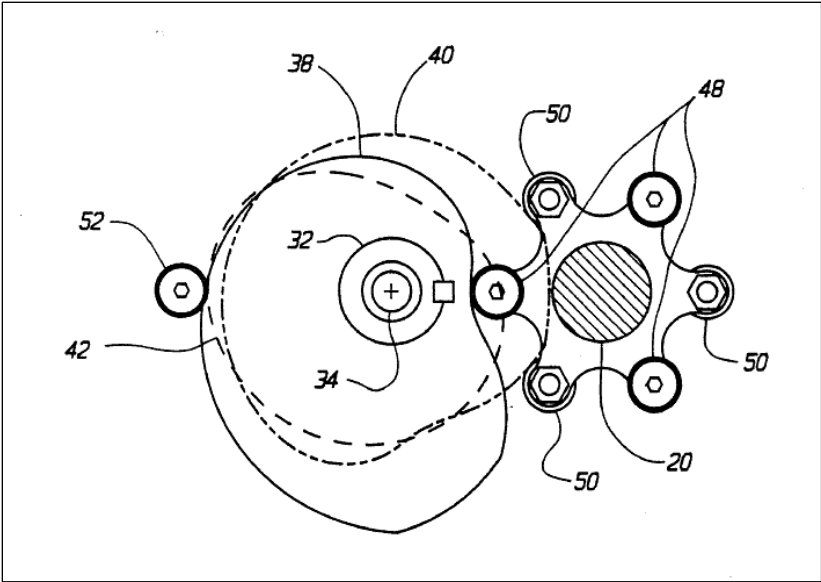

Figure 4: Parallel Shaft Drive and Index Machine

Another option for indexing is the “Geneva Mechanism”. This term encapsulates a variety of designs, with the basic concept shown in Figure 5. This concept allows for intermittent rotation in one direction, but has the cons of being a purely mechanical device and therefore being subject to wear, as well as causing excessive noise due to the mechanical interactions of the parts.



There are commercially available products designed for the purpose of indexing. These come in a variety of forms, and are driven by motors, servo motors or pneumatics. A servo driven option was available through the automation manufacturer, Festo. Shown in Figure 7, it incorporates a timing belt, except that many of the negatives associated with such a system had been resolved. The belt of this product is internal, and is driven by two servo motors in order to eliminate vibrations in the belt. On the top side of the belt is a guide that could be used to mount an assembly on top. This type of system could position the top guide with repeatable precision.



Figure 7: Festo Toothed Belt Axes Drive

A similar type of system was also available from Festo, except instead of using a timing belt for positioning, a ball screw was used to provide positioning of the guide rail. These systems offered a more precise ability to locate the guide, but lacked the speed that would be necessary for our operation.

## 1.2 Grabbing

One of the design specifications is to grab the product and pull it with enough force to move through the machine without damaging it. Two concepts we researched were mechanical



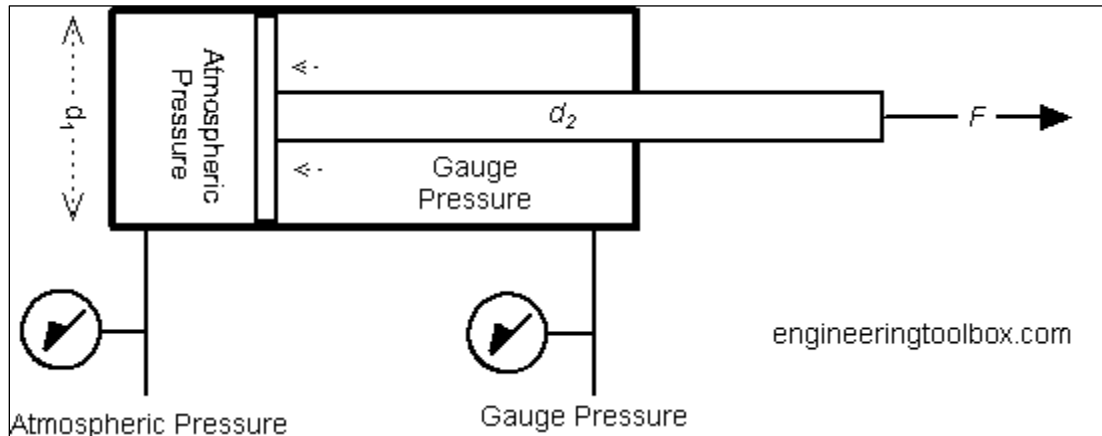

Figure 9: Piston-Cylinder Schematic

In Figure 9, the piston is the “T” shaped part resting inside the cylinder. From the diagram it is clear that force is exerted onto the piston from the gauge pressure, which is higher than the atmospheric pressure, causing the piston to actuate.

### 1.3 Merging

A process that must be completed by our design is the combination of the two lines of product resulting from the slicer. At the commencement of this project, the sponsor informed us that their aim was for us to create a novel solution for the processes. Therefore, it was determined that research would not be done into the systems that the sponsor is currently using or has used in the past. It was believed that the influence of knowing previous setups would bias our design towards a similar solution. Therefore, we researched patents not related to our sponsor.

Several thoughts were kept in mind when completing research into patents. As stated by our sponsor, we were looking for the simplest solution to the problem of merging, using the fewest parts and least motion possible. Our investigation was conducted using Google Patents as

the search engine, as opposed to the United States Patent Office, due to a much more manageable website and patent viewer.

A patent found regarding merging technology was Ted Haan's "High Volume Conveyor Sortation System", US Patent Number 7128197. Although the products being moved within the patent and the path lines were very different to ours, a couple of important points were made in the text of the patent. Mr. Haan explained that the two most critical parts of merging multiple product lines was timing the line offsets and maintaining the orientation of the two lines entering the resulting line. The importance of these two actions was kept in mind during the design of the merging mechanism.

John Cragun's "Lane Merger Apparatus" was found to be more similar in shape to our product lines. A picture of Mr. Cragun's patent can be seen in Figure 10. The concept of his patent is that three lines of product are shot into a single resulting line using belts on top of a conveyor belt. The largest difference between the merging system that we must use and this patent is that our product could not be joined using angles due to its length. When this was realized, we determined that the tracks entering the merging process must be parallel and maintain this orientation as to not deform the product. In addition to this, Mr. Cragun's patent uses belts to feed the product into the merging station, which we determined would not be the best way to handle the product.

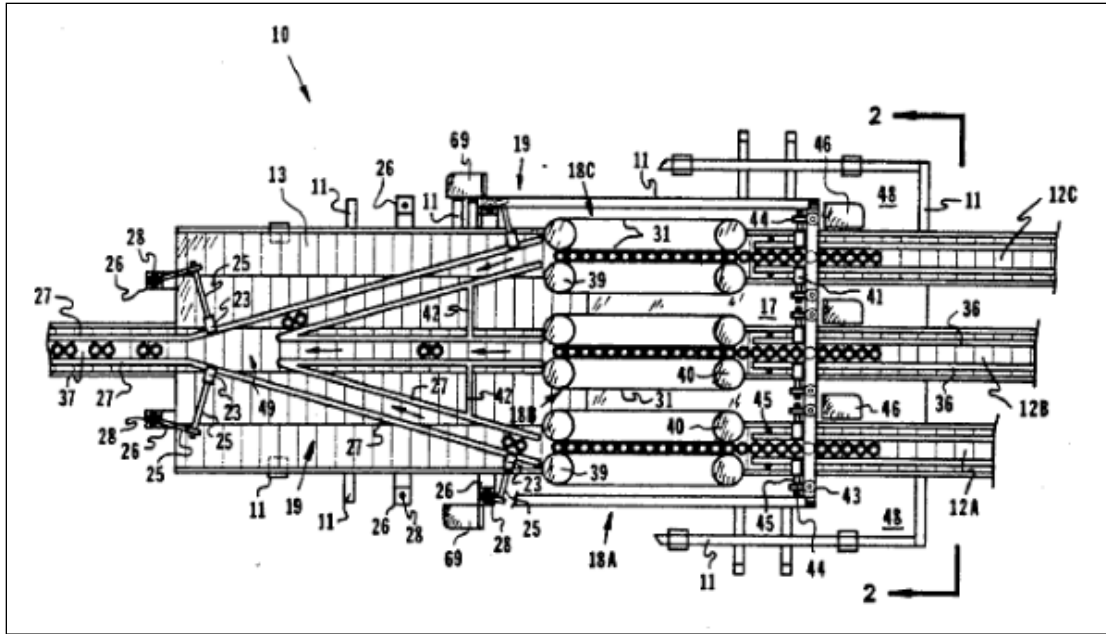

Figure 10: Lane Merger Apparatus

An alternative to having parallel tracks entering the merging station was introduced by US Patent #4265356, Charles Glover’s “Apparatus for Combining Articles from Plural Lanes into a Single Lane”. An image from the patent can be seen in Figure 11. Mr. Glover’s mechanism has four lines of product that enter from the left and are held in their tracks by a plate broken only by the resultant track. The resultant track pivots back and forth and accepts individual products from each of the lines as they align. As long as the track that accepts the product is lined up with the product, the tracks don’t have to be parallel entering the merging station. There is still a flaw in this design, however. There is only one point in the rotation of the track that allows for the product to leave the track. Therefore, even though the rotating part of this assembly could accept both of the lines of product during one swing, it could only output one of the products into the resulting line per swing.



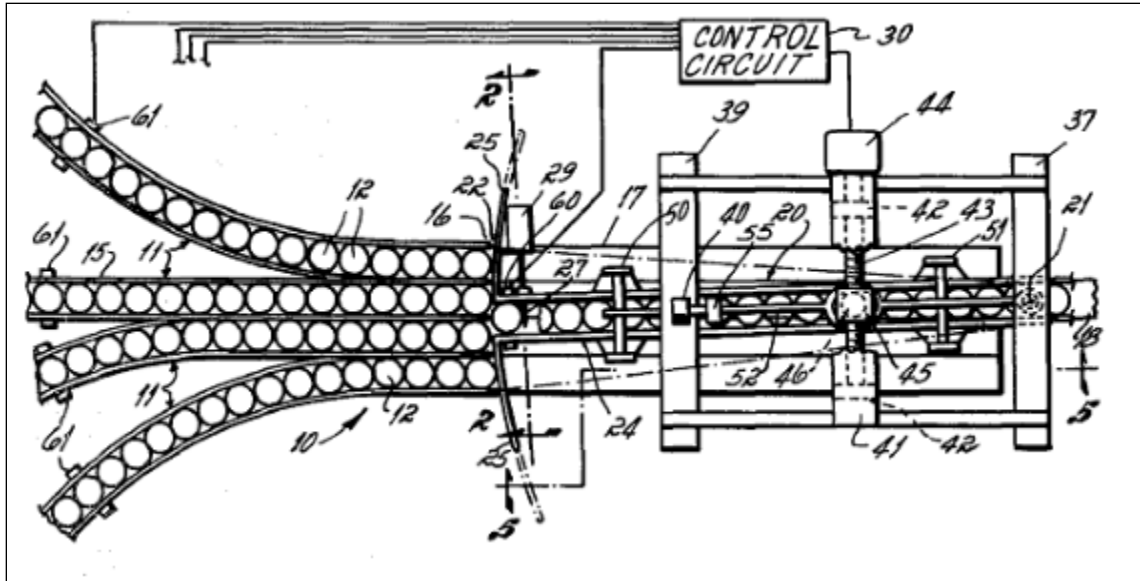

Figure 11: Apparatus for Combining Articles from Plural Lanes into a Single Lane

During the design process, we searched to see if there was a patent similar to our concept of a shuttle driven by solenoids. Using search terms such as shuttle, merging, product lines, and solenoids, we did not find a patent with a similar design.

#### 1.4 Material Properties

This project required material testing and analysis in addition to machine design. The product being tested was brittle and weak but needed to be fed through a machine in a way that would not damage it. Research on the material properties of the product was done, but there were no available resources to satisfy our needs. The material properties needed were ultimate tensile strength, breaking force, yield strength, and Young's Modulus.

The ultimate tensile strength and breaking force needed to be found because the product would be pulled along its longitudinal axis. Ultimate tensile strength is the maximum stress of the material before it fractures, and the breaking force is the force at which the material breaks

while being pulled along its longitudinal axis. Ultimate tensile strength is measured in force per unit area while breaking force is simply measured in force.

The yield strength would also need to be found to know at what stress the material would deform. Yield strength is the stress at which the material can no longer return to its original cross-section and shape. Once a material yields, it has plastically deformed. Brittle materials have a very small, and sometimes nonexistent, elastic region on their stress-strain curves. It was our prediction that the product would display this brittle behavior.

Young's Modulus was also a significant material property to test for. This was because it was important to understand how stiff the material was and how it would behave during axial loading. On a stress-strain curve, Young's Modulus is the slope of the linear region of the curve.

To find these properties, test rigs and samples needed to be made. A tensile tester (Instron) was available to us through the Biomedical Engineering Department at WPI. The jaws of the Instron could not grab the raw material without crushing it. Therefore, we needed to successfully grip the material so that it could be pulled in the Instron. We experimented with different types of grips and adhesives to attach to the ends of our test specimens. After several trials, wooden dowels with an epoxy adhesive worked the best. All of the necessary material properties were able to be found using the Instron machine. The results of these experiments are described in detail in Section 2.3.

## **2. Preliminary Analysis**

### **2.1 Sponsor Feedback**

In our initial meeting with the sponsor company, we were able to tour their manufacturing plant as well as meet with the engineers and liaisons. We were given descriptions of all the available projects and had a questions and answer session. The sponsor explained which projects were more design oriented and which were more analysis focused. From there, the group chose a project from the list and began research and the design process.

During the course of our design process, we had biweekly design reviews with a liaison who worked for the sponsor company. In these design reviews we discussed what work had been completed since the last meeting, such as design changes, improvements, and test results. The liaison provided feedback to help improve what we had already accomplished. Some major topics during the design reviews were our progress on the project and if we were on track, presenting different concepts for each machine station, reviewing our calculations for different parameters of the design, and analyzing the material testing data.

Our liaison also guided us to the most efficient method of machine design. He sent us a step by step guide on how to dissect our concepts and turn them into functioning designs. He also aided us by giving advice on how to analyze and interpret the data we collected to improve our designs.

The sponsor company and our advisor also helped us in finding suppliers to buy parts from for our prototype. They also sent us hardware and parts of their own that we were able to use.

## 2.2 System Analysis Using CAD

In order to better understand the mechanism that must be designed, a 3D model of the infrastructure at the output of our design was created. CAD (Computer aided design) models of the load mechanism were provided by our sponsor in Parasolid format, and imported into Solid Works. However, Parasolids provide no intelligent features and it is not possible to edit or move the resulting parts in assemblies. It was decided that a full, moving, assembly would be of the best use to us, so the Parasolids were converted into Solid Works native files. The feature recognition algorithm in Solid Works created feature trees for each part, with a few exceptions which we manually fixed.

Unfortunately, the created assemblies' components were all grounded to one another and had no dynamic constraints, so the newly created native parts were put together in a new assembly file. This was accomplished by dividing the overall assembly into sub-assemblies that each team member created. This new assembly only used constraints that would be in the tangible assembly, so the CAD assembly moved just as it does in the factory. The complete model cannot be shown due to proprietary reasons, but the mechanism worked and showed us the scope of the project. Several parameters were defined using this method. One of the primary reasons for building the CAD model was ensuring that the mechanism we created would not interfere with the motion of the nestings on the assembly line. Therefore, after our CAD assembly was completed, it would be inserted into the overall assembly of the existing infrastructure, using two mounting planes provided by our sponsor as references.

The mounting planes are another point that had to be incorporated into the design. The current system uses dowel pins for positioning and tapped holes and screws for securing. Grounding the assembly that we have created is important to ensure that there were no vibrations

or stresses that would result in performance drops of the system. Therefore, keeping in mind mounting will be another important aspect of designing our assembly.

## 2.3 Material Testing

### 2.3.1 Introduction

Material properties of the product were found to use in the calculations for our design. Four material properties were found using the Instron:  $S_{ut}$  (ultimate tensile strength), Young's Modulus, yield strength, and the breaking force. The  $S_{ut}$  is the maximum stress the material can withstand before it fractures, or the maximum load sustained by the specimen during the tensile test.  $S_{ut}$  is important because it's used in calculating the correct pressure needed for the grabbing mechanism in this design. The yield strength is the stress at which the material is plastically deformed, or the point at which the specimen experiences permanent damage (Keyser). Yield strength is important to this design project for the same reason that  $S_{ut}$  is. Additionally, the sponsor company requested this material property for their records. The Young's modulus describes the stiffness of the material or shows the elastic resistance of the material to strain (Keyser). It is important to understand how stiff the product is when designing a machine to pull and push it. The breaking force is the force at which the material breaks when being pulled. The product needed to be indexed through the machine, which meant that it would be pulled along its longitudinal axis, making the breaking force an important parameter in our calculations. These material properties were found in order to help us design a machine that did not damage the product while it was being fed and for the benefit of the sponsor company.

The results of the material testing were calculated based upon engineering stress and strain, not true stress and strain. Engineering stress does not consider the changing cross-section of the test specimen. Engineering stress is the applied force divided by the original cross-section of the material. True stress is the force applied divided by the instantaneous cross-sectional area

at a given time. Engineering stress and strain were used in this test because of its practicality in this application.

### **2.3.2 Methodology**

The product had to be secured in the Instron with grips. These grips were manufactured from 3/8" wooden dowels with 3/32" x 1/2" holes drilled through their centers on a lathe. The product was fastened in the dowels with a 2-part epoxy. The samples were set up on the Instron with the following parameters: A rate of 8.896 N/min with end conditions at 0.03 m or 88.96 N. These numbers were selected based on the initial hands-on testing. From experimentally pulling the material with our fingers, it was concluded that the product would break well before 20 pounds of force, which is approximately 88.96 N. The rate was chosen arbitrarily to be 2 lbf/min, which is 8.896 N/min. The Instron collected elongation data and force data from which stress-strain curves were generated. Figure 12 shows the average stress-strain curve for all 8 samples tested.

### 2.3.3 Results

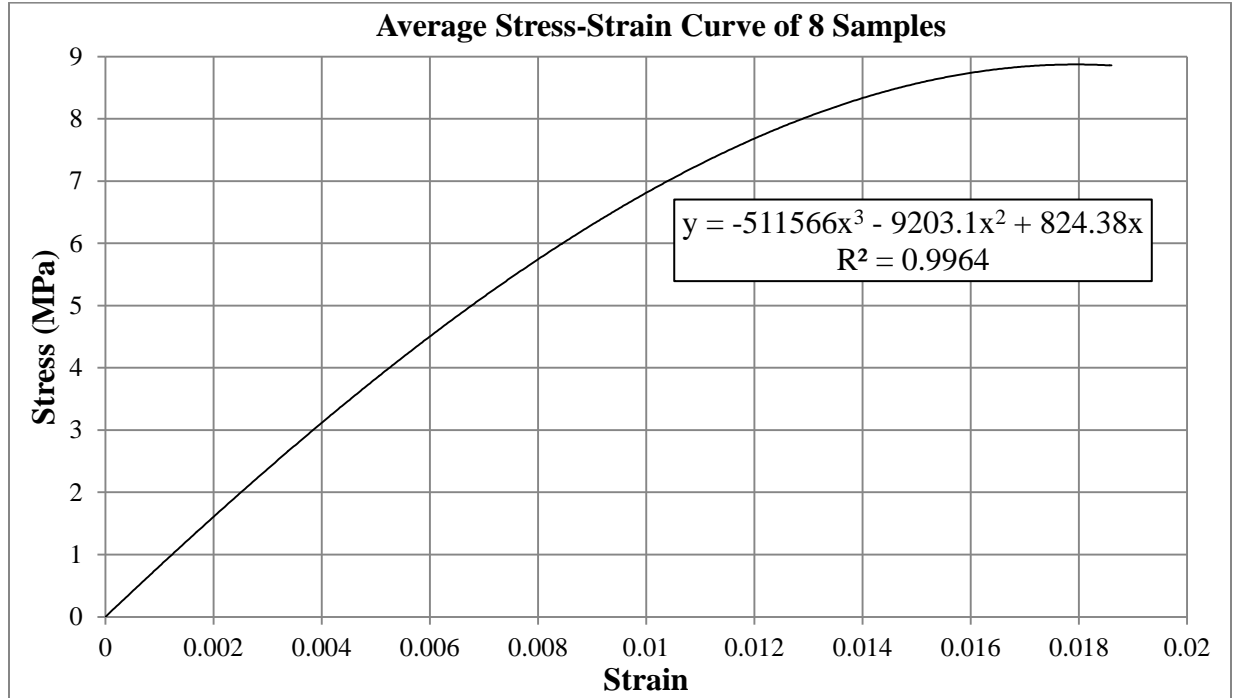

Figure 12: Compiled Data Stress-Strain Curve

A cubic function with an  $R^2$  value of 0.9964 was fit to the data. Its formula is:

$$F(x) = -511566x^3 - 9203.1x^2 + 824.38x \quad (1)$$

The ultimate tensile strength was found by deriving equation 1 and obtaining its roots. The roots of the derivative of equation 1 will give the values of strain at which the stresses are maximum.

The derivative will have two roots as it is a quadratic equation. The derivative of equation 1 is:

$$F'(x) = -18406.2x - 1534698x^2 + 824.38 \quad (2)$$

The roots of this function are (-0.03, 0.018). Evaluating equation 1 at the positive strain of 0.018 gave a y-value of 8.84 MPa, which was the ultimate tensile strength.

The yield strength and Young's modulus were found by generating a line parallel to the origin of the stress-strain curve and offsetting it by .2%. The slope of this curve was the Young's



modulus and the point of intersection with the average stress-strain curve was the yield strength.

The equation for this offset line is shown in equation 3 below.

$$G(x) = 800(x - 0.002) \tag{3}$$

The stress-strain curve, the 0.2% offset line, the ultimate tensile strength and yield strength are plotted in Figure 13 .

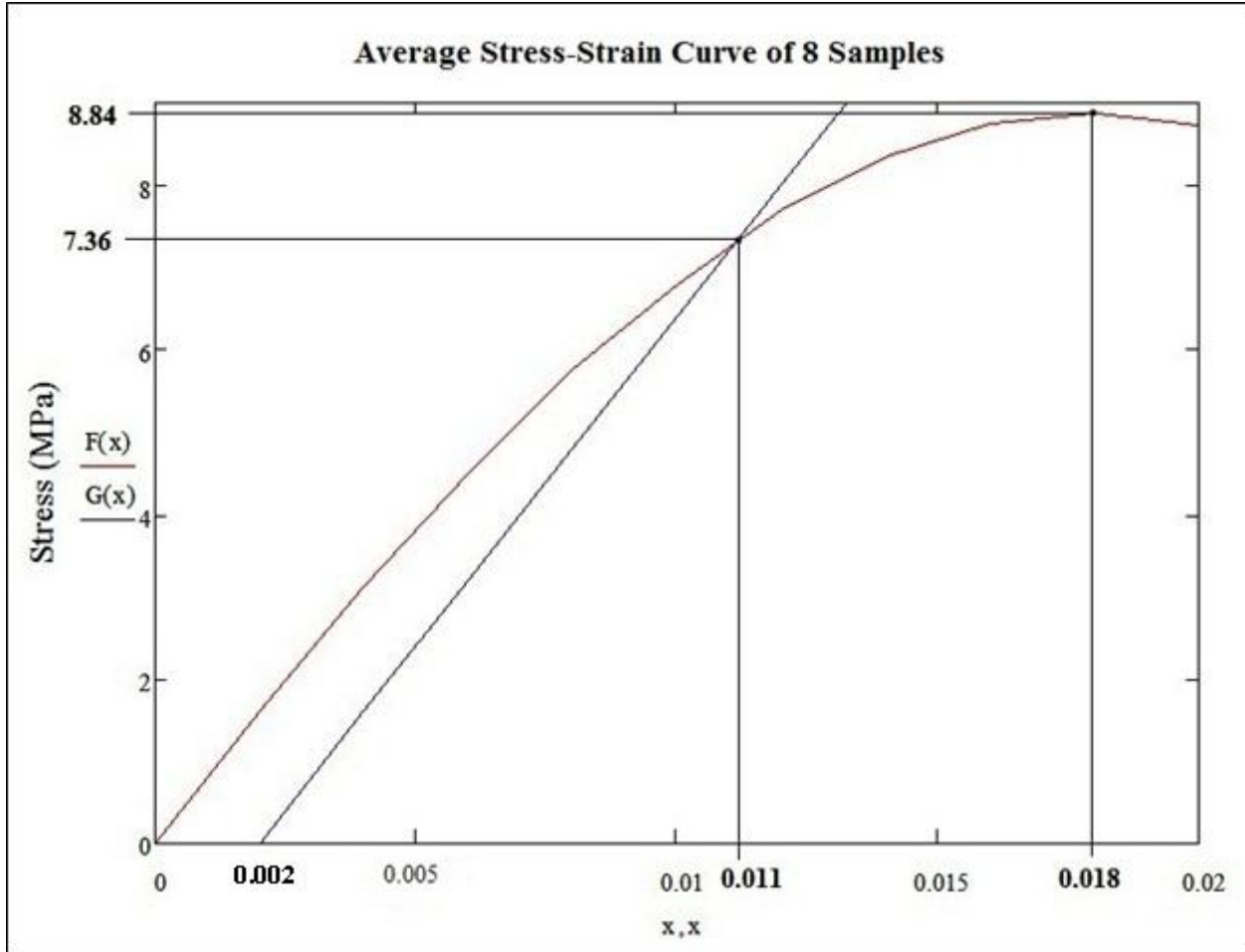

Figure 13: Stress-Strain Curve Compiled Data

The tabulated data is shown in Table 1.

---

Table 1

Young's Modulus (MPa)	<b>800</b>
Yield Strength (MPa)	<b>7.36</b>
Ultimate Tensile Strength (MPa)	<b>8.84</b>
Breaking Force (N)	<b>27.3</b>

---

Table 1: Material Properties

### **3. Design**

After breaking down the problem statement and completing background research, the team was ready to begin design iterations on the three different processes that had to be completed: indexing, grabbing, and merging.

#### **3.1 Indexing Design**

Linearly indexing the product was one of the main design goals of this project. While preliminary design concepts ranged from the Geneva drive to an eccentric crank, the final design provides a simpler solution.

##### **3.1.1 Early Design Iterations**

A slider-crank mechanism is an efficient mechanism for transmitting linear motion. However, with an extremely small stroke (less than 50 mm), it becomes difficult to create cranks that are the necessary size to complete the motion. The mechanism requires a crank that has axes 14 mm apart. This means that even if the shafts used to transmit motion were a mere 5 mm in diameter, there would only be 9 mm of support left between them. This does not provide the link with enough structural integrity to last the required length of time. Therefore, we determined that an eccentric crank would replace the original crank in the system, shown in Figure 14. Figure 14 shows the eccentric crank (1), the structure that is used to pin the links together (2), and the second link in the structure (3).

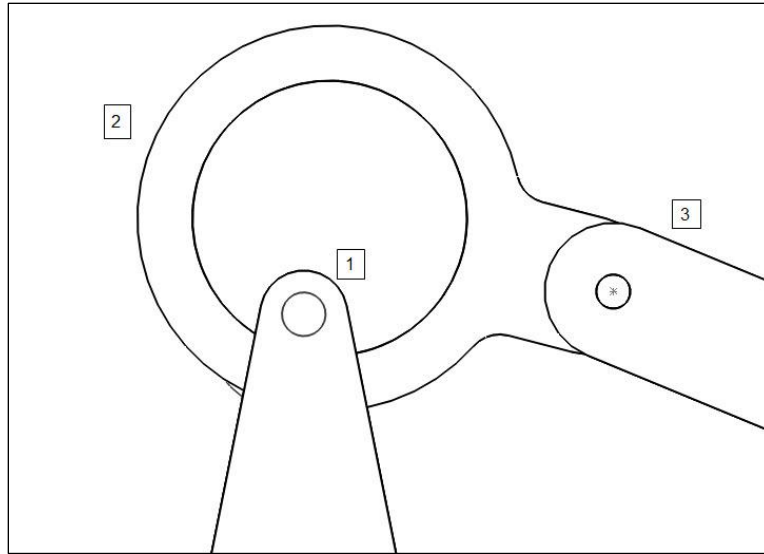

Figure 14: The Initial Design of the Eccentric Crank

Conceptually this design worked; however, there were several practical issues with it. There is a very large piece of eccentric metal rotating at moderately fast speeds, which created issues with vibration and stabilizing the structure. One possible solution for this problem was adding stabilizers to the structure holding the crank. However, adding more stabilizers created another problem: where to keep the product in relation to the indexer. We considered two possible solutions to this problem. The first was to add a counterweight to offset the momentum of the eccentric crank. The second was replacing the vertical crank with a horizontal crank, as shown in Figure 15. This rotation created several problems in addition to the previous problem. It became more difficult to link the device together, a thrust bearing became necessary to support the weight of the eccentric crank, and securing the assembly together became more complicated. The final problem was with the bronze bushing, which needed to be a minimum of 90 mm in diameter. Most commercially available bushings are not available in this size, so the bushing would need to be a custom part. This drives up the machine cost and could make repairs more

time consuming. While searching for a complete solution, the rotated eccentric crank of Figure 15 was derived.

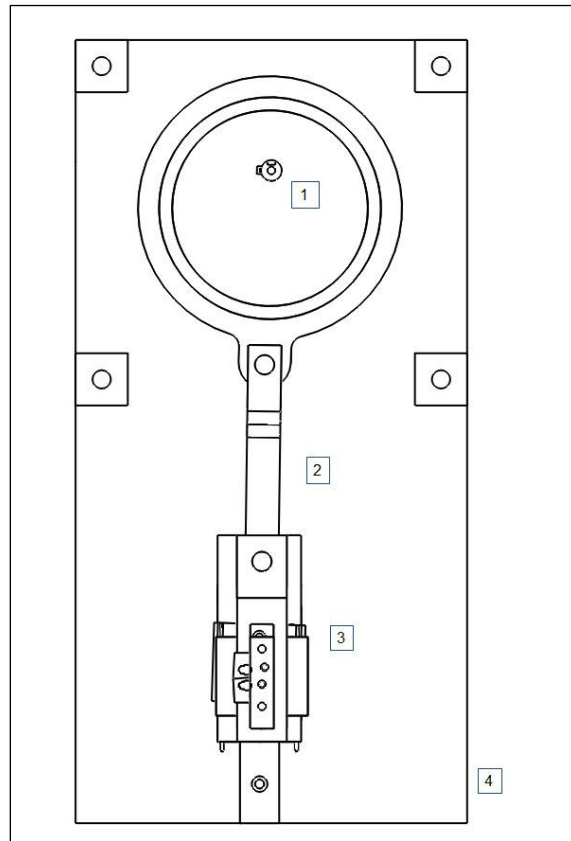

Figure 15: The Rotated Eccentric Crank

Figure 15 is a top-down view of the horizontal crank system. Figure 13 displays the eccentric crank (1), the connecting linkage (2), the piston grabber (3), and the base plate of the system (4).

### 3.1.2 Linear Slide

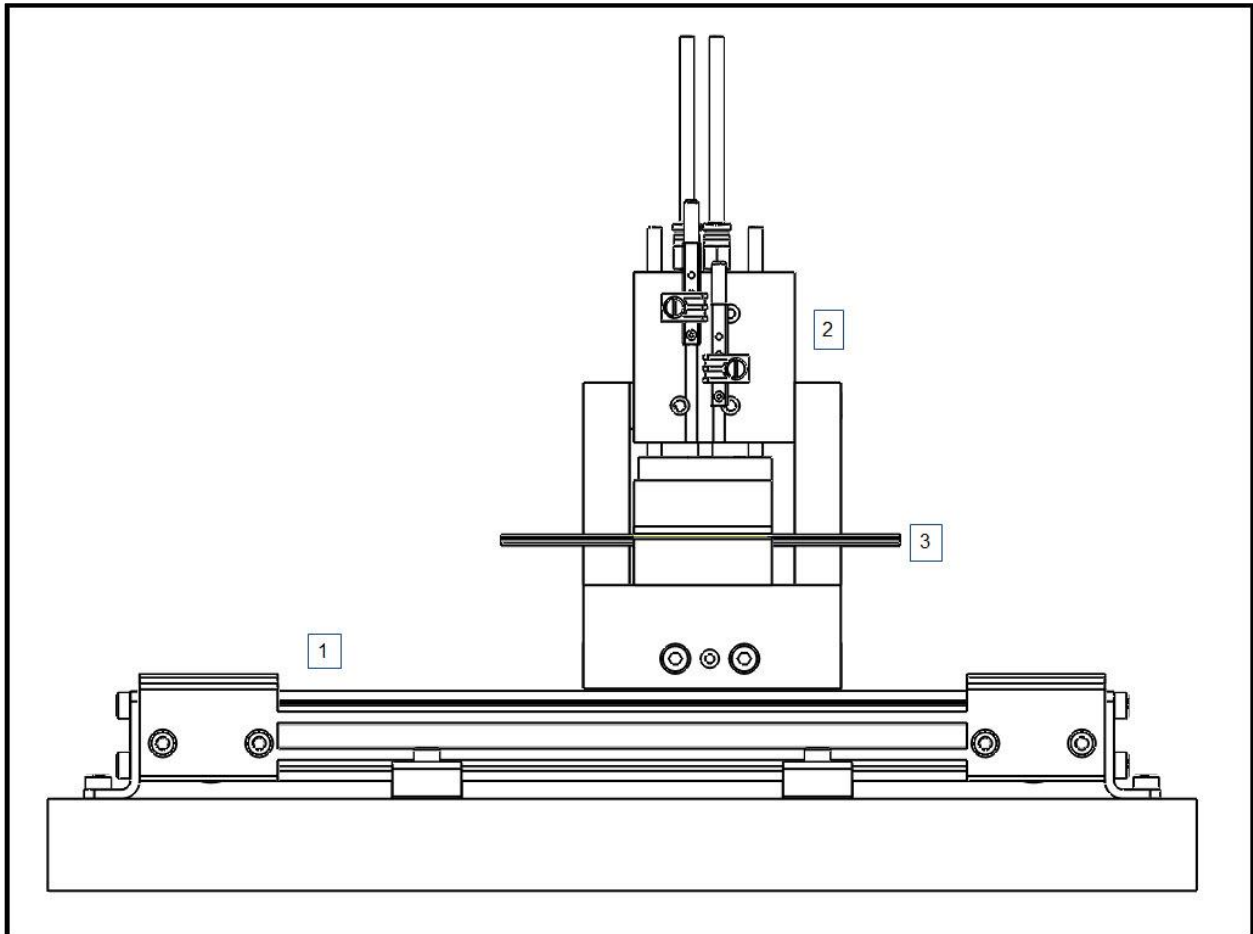

Figure 16: Indexer-Grabber Assembly

The final design utilizes a Festo toothed belt axis (1), Part Number 193739 shown in Figure 14, which creates the linear motion required. The grabber (2) is shown loaded with the product (3).

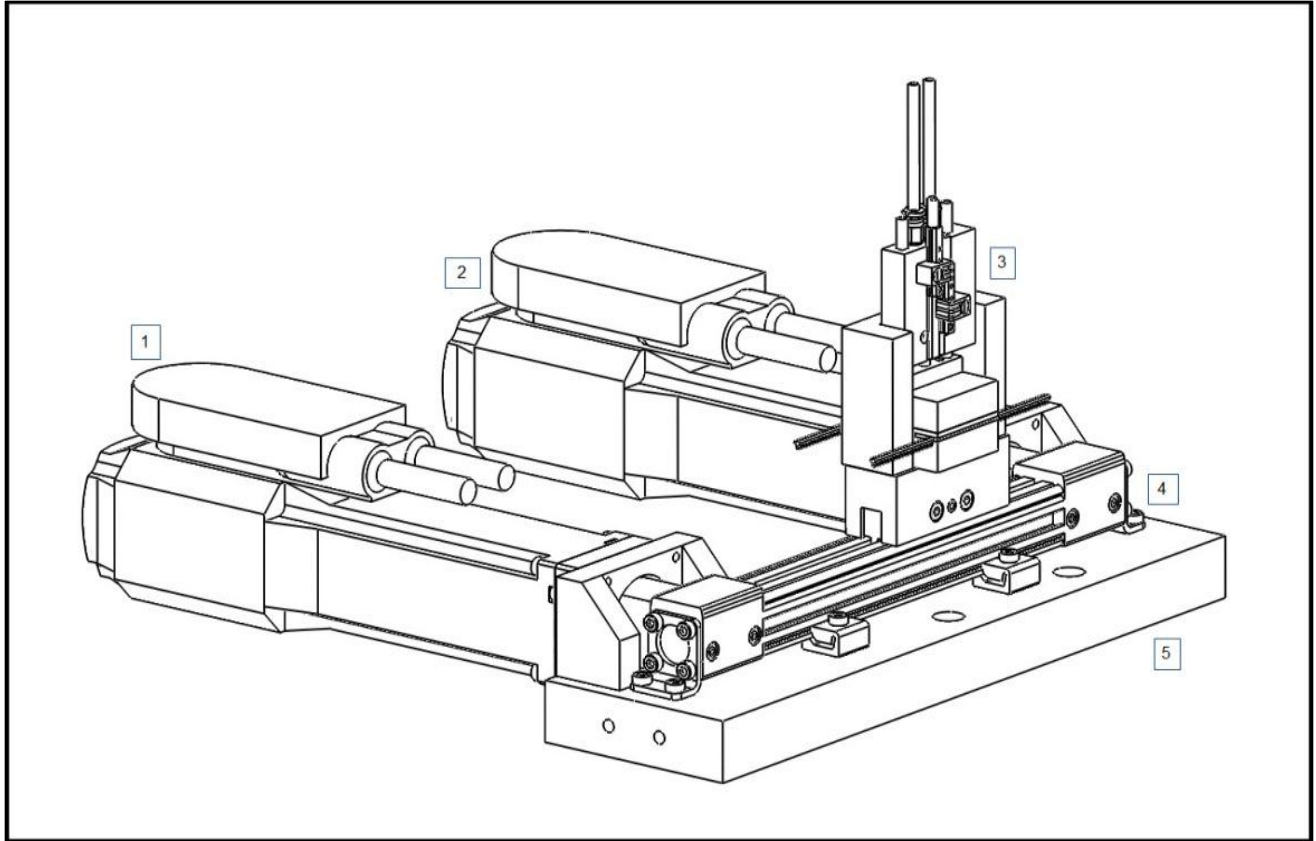

Figure 17: Complete Indexing Assembly

The slide (4) is a Festo toothed belt axis (Part Number 193739) with a 30mm stroke and allows for two servos (1&2) to be used. While using two servos is not required, it prevents slack in the internal belt from interfering with the operation of the assembly. Using two servos also reduces the duty cycle for each servo which allows the machine to last longer without maintenance. The grabber (3) and the base plate (5) are also shown for reference.

Figure 18 displays the velocity profile for the servos. According to the velocity profile, the piston grabber is stationary for nearly 50% of the cycle time. This allows time for the piston to both grab and release the product. This profile also provides a complete deceleration for the piston grabber.

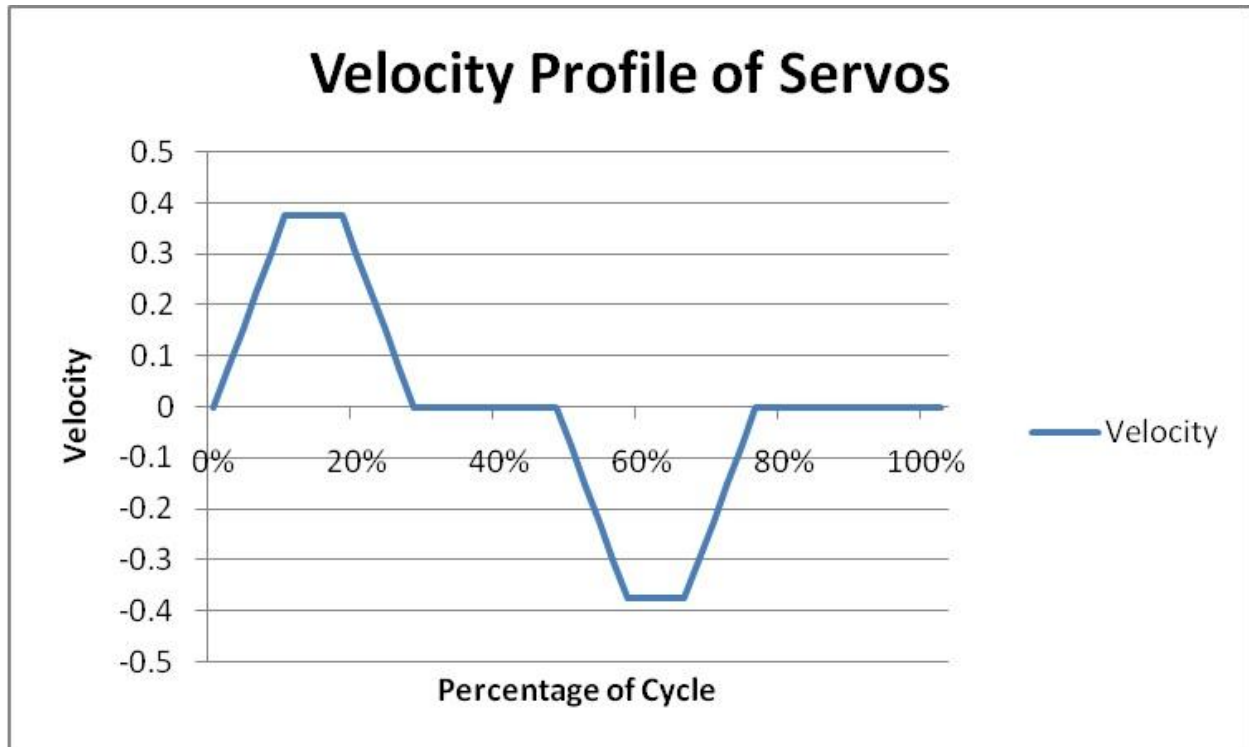

Figure 18: The Velocity Profile of the Servo Motor

The linear slide, the servo motors, and the brackets are Festo parts. The only custom parts used for this are the base-plate as well as the motor braces, shown in Figure 19. The servos and the coupler kits are suggested for the linear slide by Festo. As the servo did not have a solid way of attaching to the rest of the assembly, special brackets were designed to give the servos greater stability. The drawings for this part are located in Appendix A: Indexing and Grabbing Mechanism Drawings.



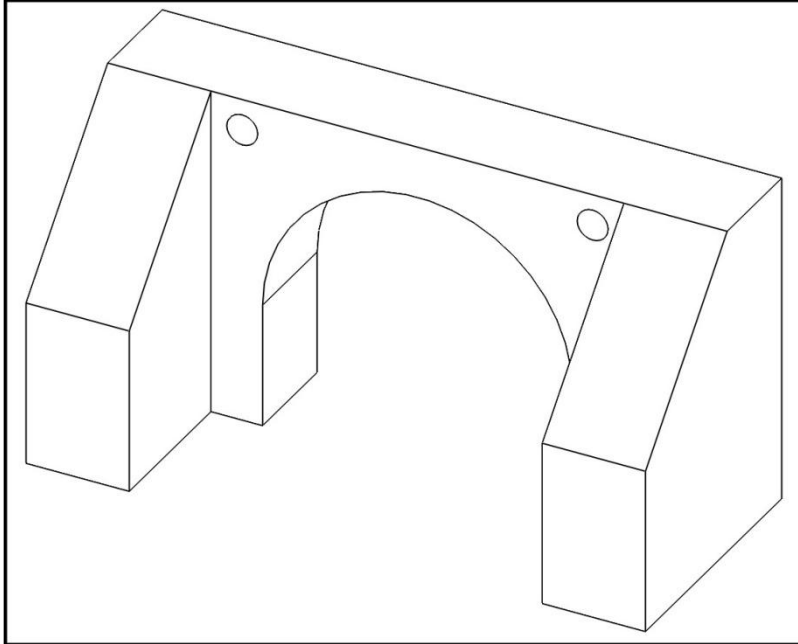

Figure 19: The Custom Motor Brackets

## 3.2 Grabbing Design

A key element that needed to be developed was a mechanism to grab the product and control it as a part of the indexing motion. It would firmly hold the product while forward indexing was occurring and then release and not interfere with the product during the return cycle. The design of this component was dependent on the indexing mechanism used, so the two motions were developed concurrently. The open ended nature of this challenge led to many different iterations and concepts, of which the highlights are outlined in this section.

### 3.2.1 Spring Gripper

One of the first concepts developed was a purely mechanical device, shown in Figure 20. It relied on a tension spring (1) to provide the gripping force on the product, and a mechanical lock (2) to keep the upper block from closing on the product while the grabber was indexing

counter to the desired flow. In Figure 20 below, the flow of product is from right to left. The picture on the left shows the lock hitting a stop (3) and allowing the tension spring to close the top block (5) on the product (8) and bottom plate (6). In the figure to the right, the lock hits a fixed point (4) which causes the top block to rise until the lock snaps into place. This allows the mechanism to index backwards without interfering with the product.

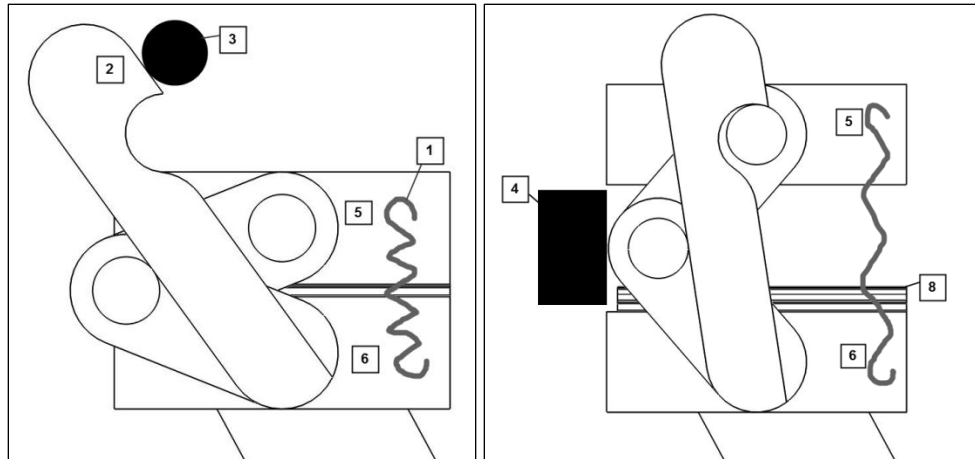

Figure 20: Spring Gripper

This iteration had flaws which forced the team to continue searching for alternative solutions. The locking mechanism would have been difficult to precisely control, and tension springs do not have a long lifespan. This would have caused uncertainty in the mechanisms ability to operate consistently without needing to be shut down for repairs or to replace parts.

### 3.2.2 Hug Feeder

Another design was designated the “Hug Feeder”, shown in Figure 21. The product would be pushed along in a track by a fourbar driven “hugger”, which is the black component in Figure 21 mounted on a sliding track that was free to move in the vertical direction.

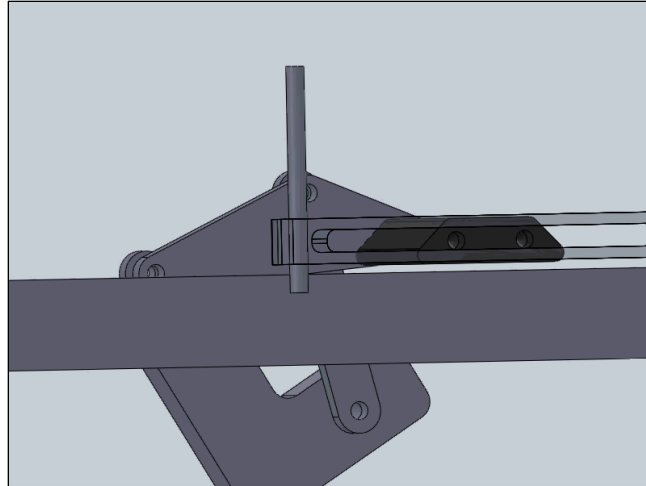

Figure 21: Hug Feeder

As the fourbar rotated the hugger would move in a straight line while in contact with the product, pushing it forward. After it had traveled the desired distance, it would rise vertically in a near hemispherical pattern and return to its starting point where it would again contact the product. A problem found with the concept was the danger of crushing the product in the process of moving it. The hugger would not have any give, and even if a soft rubber was used for its construction it would be difficult to be sure the product would have the appropriate force given to make it follow the desired flow path. Another problem was that the vertical guides needed to be relatively far apart to allow for the sliding movement of the hugger. This would lead to a poor bearing ratio and introduce the problem of racking. An improvement that was investigated for this design was a spring loaded pad on the bottom of the hugger which could provide some flexibility for the product contact zone, but this was not enough to overcome the other obstacles presented by this option.

### 3.2.3 Mechanical Grabber

One concept on which much development was invested was the mechanical grabber. This concept relied only on mechanical devices to control its operation, which offered both pros and

cons. One of the first iterations of this device is pictured in Figure 22.

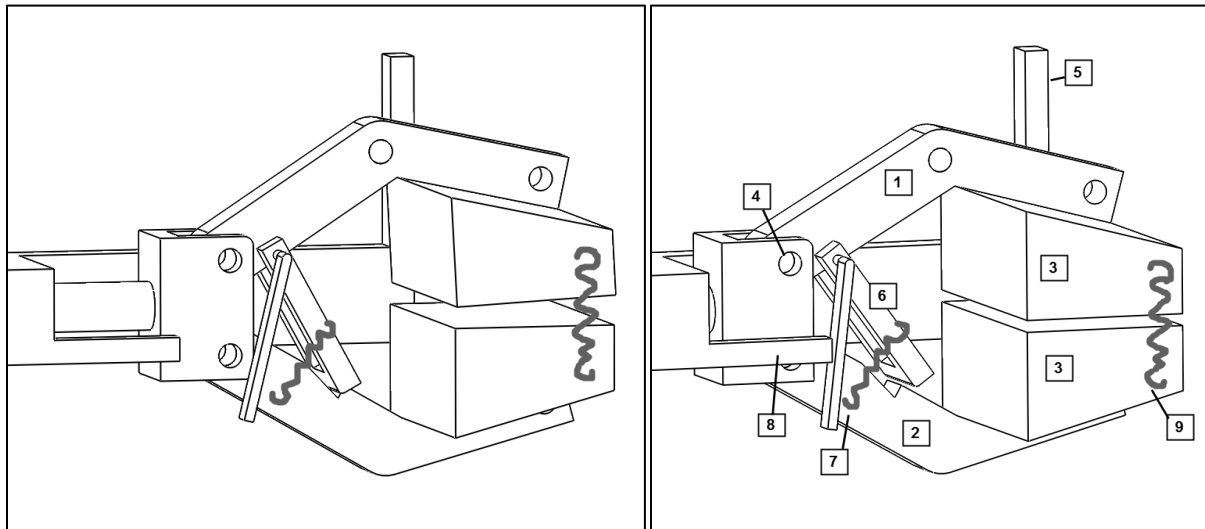

Figure 22: Mechanical Grabber

In this early design, jaws (1&2) held two blocks (3) which would be used to contact the product. The bottom jaw (2) was fixed, while the top jaw (1) was able to rotate about a pivot at one end (4). The idea was similar in practice to the spring grabber, but differed in its methods. The device would close on the product during the indexing motion using a tension spring (9) to keep the jaws closed, and then as it reached the end of forward travel it would encounter a vertical stop (5). This would force the top jaw up and allow a tab (6) that was mounted to the top jaw from a pivot to be pulled into a slot by a tension spring (7). As the mechanical grabber moved in reverse while not contacting the product, it would hit the other stop (8), which would move the tab out of the slot and allow the top jaw to close on the product again. Some of the flaws with this design were that the stop to open the jaws would not efficiently cause the top jaw to rise, resulting in unnecessary noise and forces. The tab and jaws were controlled by tension springs which have a low life expectancy and could cause problems in operation.

A more effective version of the system was developed after gaining feedback and insight from our sponsor. This new version addressed many of the flaws of the old design, and created a possible candidate for the final design. An isometric view of this design is shown in Figure 23.

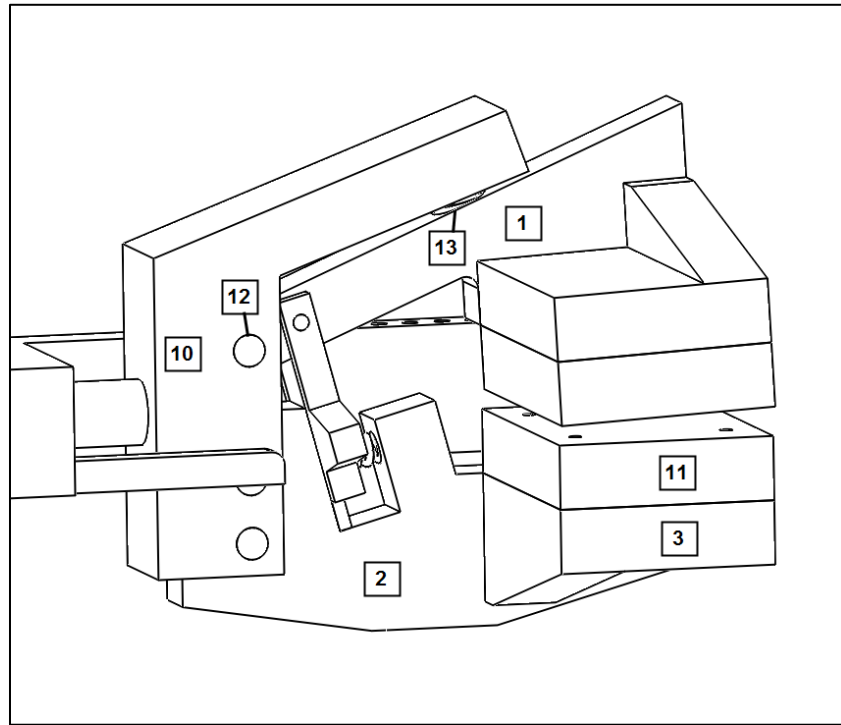

Figure 23: Updated Mechanical Grabber

The grabbing motion was controlled by stops at both ends of the extension cycle of the indexer. The bottom jaw (2) was rigidly attached to the slider crank head (10), and served as a base for the bottom of the mechanism. The grabber would move back and forth as controlled by the motion of the indexer which was translated down the shaft of part 2. Attached to the bottom jaw was a metal base (3) which had a rubber pad (11) attached to the top of it.

The top jaw (1) rotated around a pivot point (12) at the slider crank head. This allowed it to open and close on the product with a gripping block similar to the bottom jaw. The downward pressure on the product was provided by a spring (13) mounted between the top jaw and the extension of the slider crank head. The spring pushed the top jaw downwards, so it was

necessary to find a way to lock the jaw open as it moved along its return cycle. This was accomplished by putting a metal tab (14), shown in Figure 24, in the back of the mechanism attached to the base (15), which was a rigid part that would not move with the grabber. This tab would intersect with a rail (16) on the top jaw as it moved forward, opening the jaws and releasing the product.

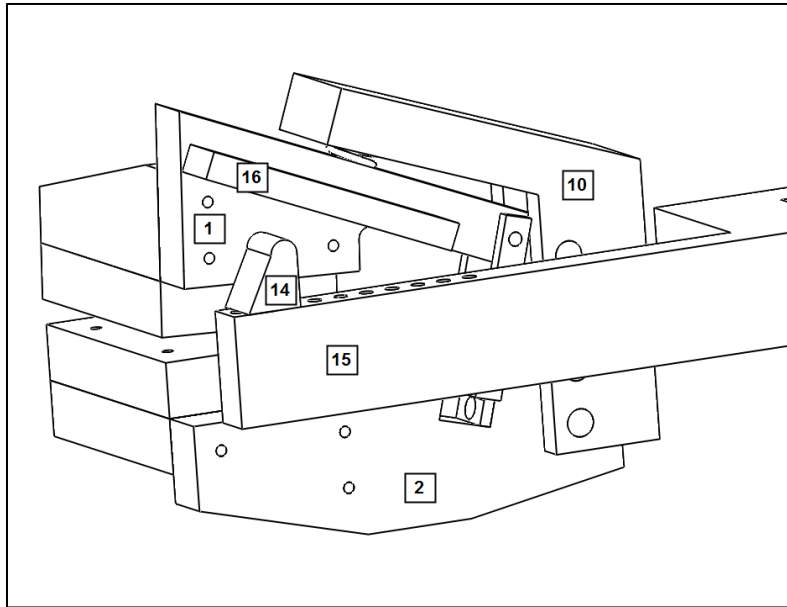

Figure 24: Back of Updated Mechanical Grabber

To keep the jaws open, another tab (17) was added in between the jaws, as seen in Figure 25. This tab locked the top jaw open after it was raised a certain amount by the top jaw. Then as the slider crank head traveled backward the tab was knocked out of its open position as it came into contact with a fixed extension of the base (8). This allowed the top jaw to close on the product.

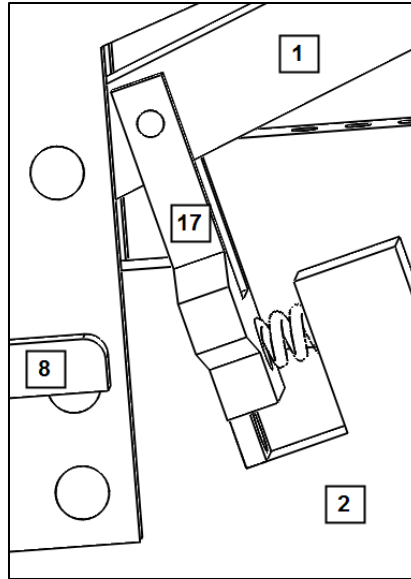

Figure 25: Tab

A benefit of this mechanism was that no outside mechanisms controlled the opening and closing of the jaws; it was entirely dependent on the mechanisms position. The amount of time that the mechanism was clamped on the product could also be adjusted mechanically by changing the positions of the stops. This allowed the mechanism to not be fundamentally altered if it needed to be adapted to new speeds or part dimensions. However, this redesign also added complexity to the mechanism, making it more difficult to manufacture. The mechanical nature of the mechanism meant that there would be parts that would wear quickly and require replacement. Those parts would be small, but extra maintenance would still be necessary to make sure it kept running properly. It would also be difficult to precisely position the stops correctly, and adjustments would be needed to make sure the jaws were opening and closing at the desired times. Because of these problems, the mechanical grabber was eliminated as a final design possibility.

### 3.2.4 Piston Grabber

Pistons were investigated as a means of controlling the grabbing motion in order to better control the clamping force on the product.

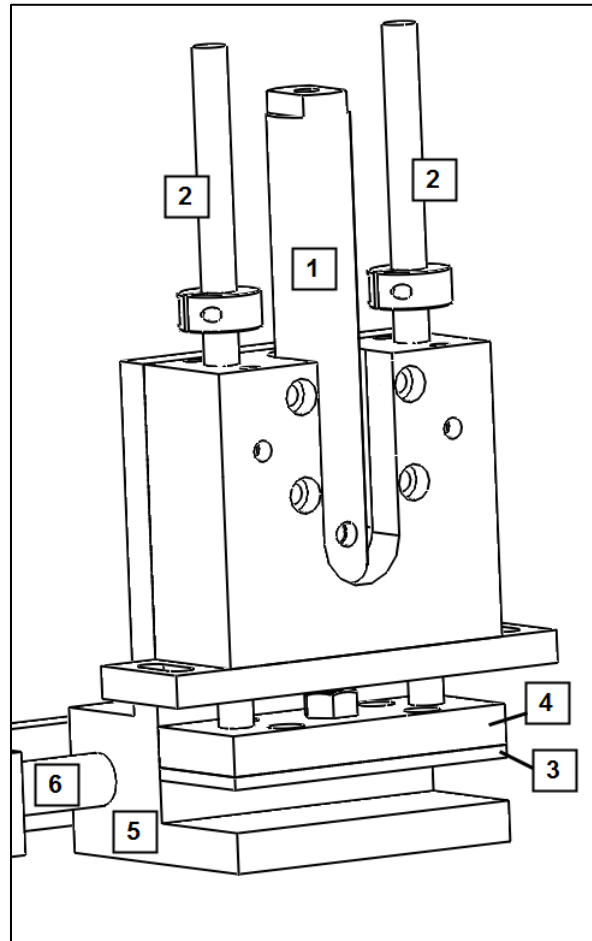

Figure 26: Piston Grabber

The design in Figure 26 has a double acting piston (1) with linear guides (2) which would be used to control the clamping motion on the product. Instead of relying on mechanical means to trigger an opening or closing motion they could be precisely controlled by sensors which would detect the piston's position as it was indexed back and forth. The double acting piston would allow for rapid grabbing and releasing of the product at precise times to reduce the uncertainty presented by a mechanical stop. The main concern with a piston was the lack of



infinite life, as pistons eventually wear out and would need to be replaced. This problem was addressed by making the piston easy to replace when necessary by having the piston easy to access and remove. The piston in this particular design has linear guides built into it to make sure that an even pressure would be applied to the product. There is a rubber pad (3) mounted on the bottom of the piston's base plate (4) which would provide friction to hold the product while the piston was being indexed forward. The piston assembly was held in place by the back block (5), which had mounting holes in the back for attaching the piston to it. It was decided that our final design would be based upon this concept. Some problems were the size of the piston selected; it was large and would generate unnecessary forces and moments as it moved back and forth. To minimize these forces a smaller piston assembly was needed. The base design also changed due to the method of indexing. For this design there was no support on the bottom of the base and the entire vertical load was transmitted down a horizontal shaft (6) that was driven by an indexing mechanism. This would have created extra stress and wear on any supports used.

The next iteration as shown in Figure 27 addressed some of the previous concerns, but left room for improvement. The piston housing was supported on the bottom by a linear guide (7), which would bear the vertical force of the weight of the piston. This guide also provided for a smooth travel path in the direction of the flow of product. The indexing motion would be controlled by an eccentric driver or similar mechanism, which would be attached to a mounting point on the side of the base (8). However, this design also had several flaws. The location where the indexing drive was attached to the base would create a moment around the guide and cause wear.

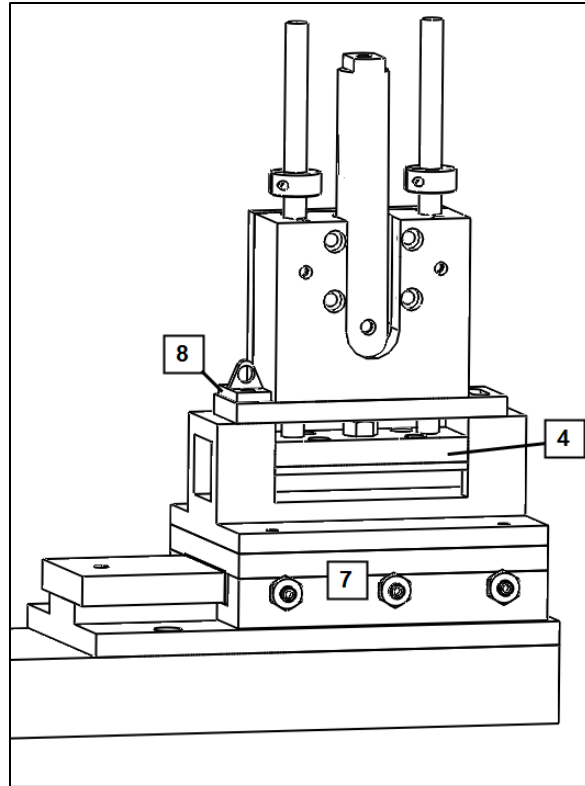

Figure 27: Piston Grabber on Linear Guide

The overall size of the guide and piston were relatively large, and if made smaller could reduce some of the torque needed by the motor that was driving the indexing motion. The width of the clamping plate (4) being controlled by the piston was also not compatible with the required 30mm width to work with the track that was being developed.

The design in Figure 28 was created to address these problems. This iteration dealt with many of the flaws of the previous ideas. The contact to connect the base (5) to the indexing mechanism was lowered, which reduced any moments on the linear guide. A new, smaller piston (1) with linear guides was selected. This piston is made by Festo, a manufacturer familiar to the sponsor. To complement the smaller size of the piston, a smaller linear guide (9) was also found on McMaster-Carr. The base (5) was built to go in between the two streams of product, with the clamping plate (4) that was attached to the piston and the receiving plate (10) extending out from

the sides of the base. This design was small, lightweight, and accomplished the desired tasks. However it was built to be moved by a mechanical indexer that was phased out of the design. This resulted in a need to modify the current assembly to work with the new indexer, and a few improvements were made. One such improvement was increasing the manufacturability of the base by eliminating the front support for the piston to make the base easier to machine. The next iteration of this concept was chosen to be the final design, and is described in detail in the next section.

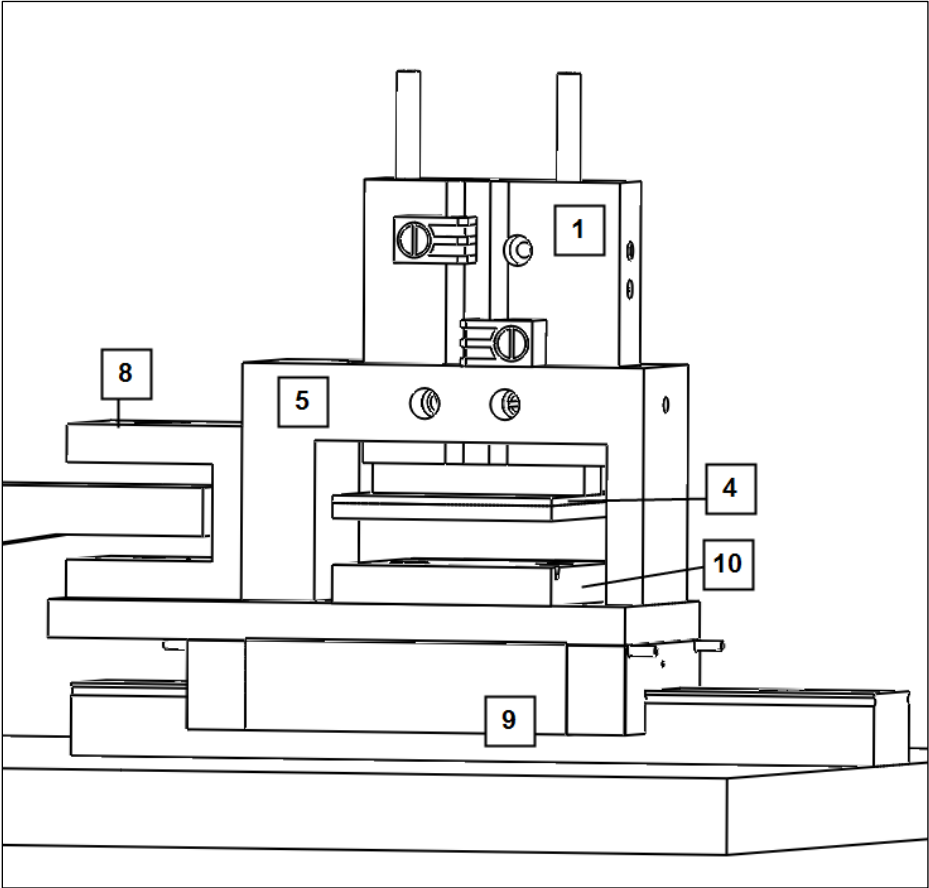

Figure 28: Smaller Piston Assembly

### 3.2.5 Final Grabbing Design

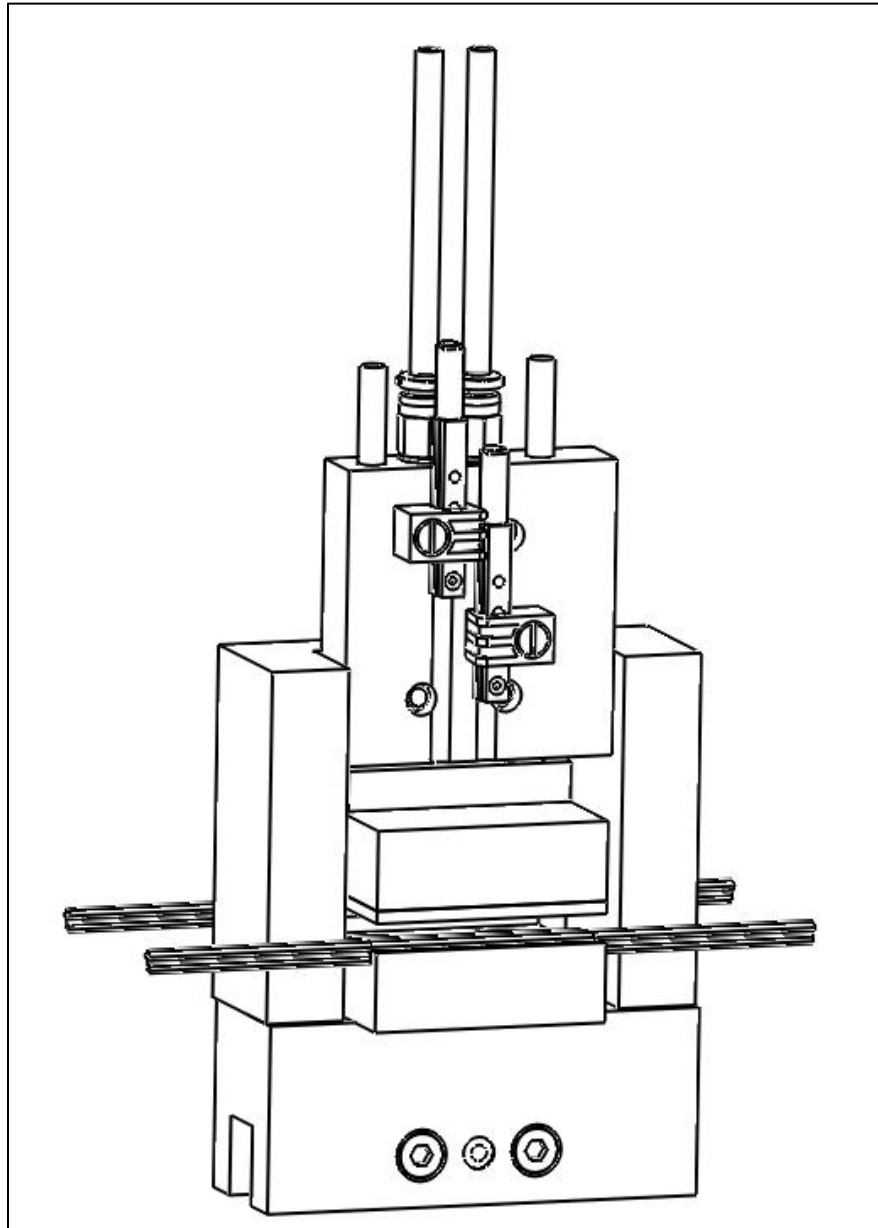

Figure 29: Final Piston Grabbing Design

The final design for the piston grabber is pictured in Figure 29. This design is the culmination of many iterations, and is fitted to mount on the final indexing method that was chosen.

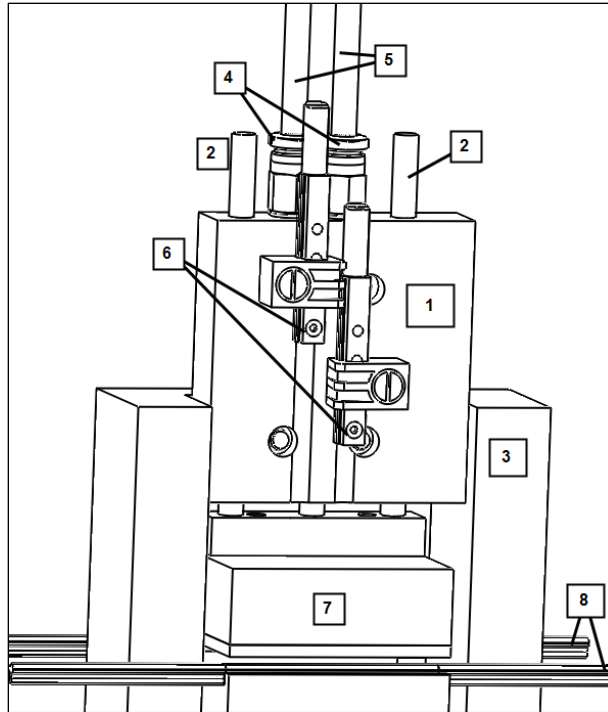

Figure 30: Piston Assembly

The piston assembly, shown in Figure 30, is double acting and has built-in linear guides (2) to keep the clamping block (7) from rotating as it translates vertically when the piston is activated. The piston chosen is a Festo Mini Guided Cylinder DCF P/N: 189455 with a 6 mm bore and 5 mm of stroke. The small size of this piston housing (1) allows for it to be easily mounted on top of the linear actuator that was chosen, and reduces the overall weight of the piston assembly. The small travel length is to ensure that there will be low impacting forces on the product (8) as the piston is activated and closes the clamping block on the product when it is indexed forward. Compressed air is fed in through hoses (5) into two 3 mm adaptors (4) on the top of the piston housing, and the position of the cylinder can be monitored by two position sensors (6) mounted on the front face. These position sensors and adaptors are available through the same manufacturer as the piston and are recommended for use together. The sensors can be used to make sure that the piston is always in the correct position relative to the cycle running,

and help to eliminate any uncertainty as to whether the piston was responding correctly to the pressure from the compressed air.

The mounting of the piston housing to its support is made easy by M2.5 pre-drilled taps already being present on the piston housing. The piston housing is mounted to the piston support (3) in three spots using these available taps.

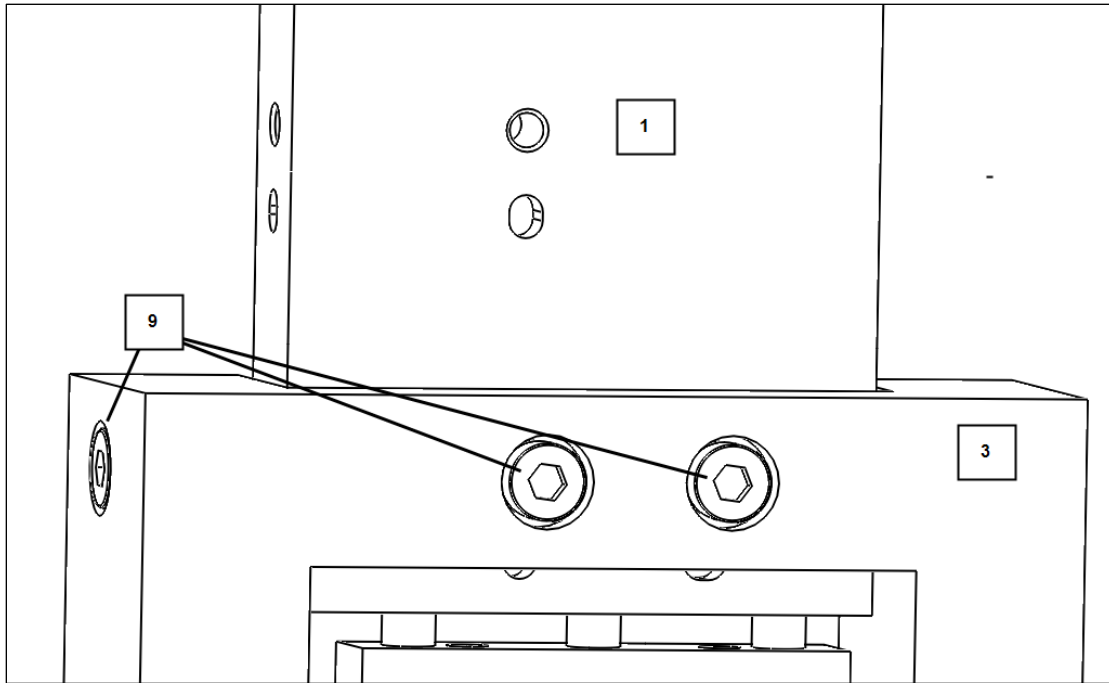

Figure 31: Back View of Piston Housing Mounting

Figure 31 shows the M2.5 hardware (9) used for this mounting. Two of the screws mount to tapped holes in the back of the piston housing through the back of the piston support shown in Figure 31. The third screw mounts to a tapped hole on the right side of the piston housing, which is on the left in Figure 31, through a counter bore hole similarly drilled in the piston support. All screws used for this mounting are the same size. Through this multi-axis mounting, the position of the piston housing is secure.

A main element of the overall piston grabber assembly is the piston support. This part is shown in Figure 32.

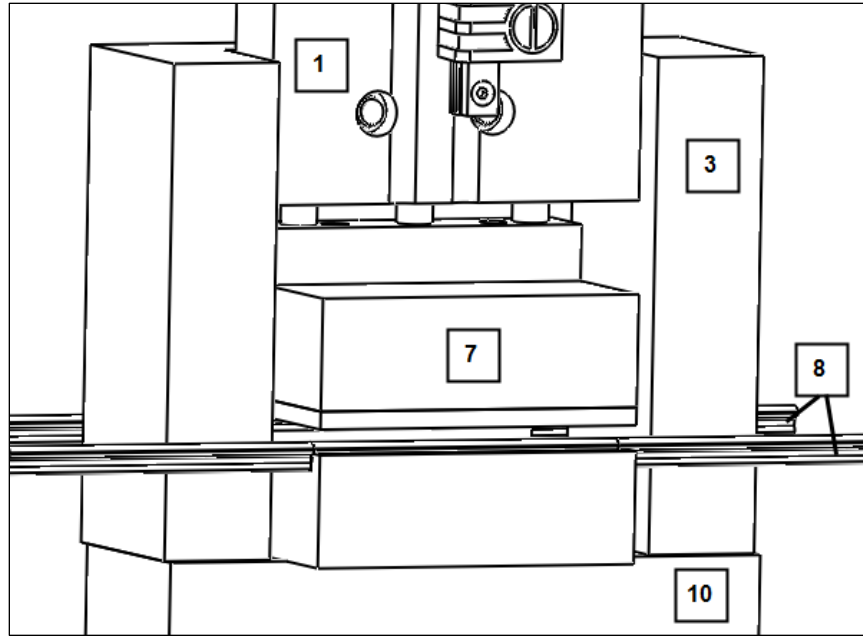

Figure 32: Piston Support

The piston support (3) is used to precisely locate the piston and keep it in the right orientation, as detailed in the previous section. The piston support is mounted to the base (10) by two M4 screws which approach from the underside of the base and lock into two tapped holes drilled at either end of the piston support. This provides a firm mounting for the piston support to the base. The piston support is dimensioned to be exactly as long as the base, 56 mm, and can be created from one solid piece of aluminum. The support is designed to be 20 mm wide, which is narrower than the 30 mm distance between the two lines of product. This allows it to fit between the flows of product on the assembly line.

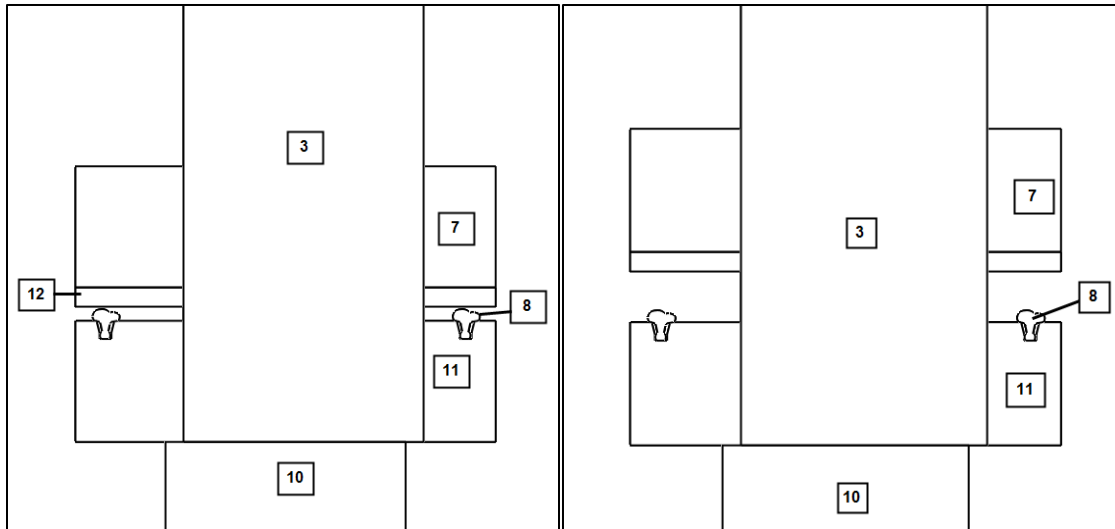

Figure 33: Piston Block in Closed and Open Position

The grabbing motion is controlled by two parts. The first is a clamping block (7) that is attached to the piston and translates in the vertical direction as the piston moves it. Figure 33 is a view facing up the line of flow of the product, with the right side showing the open un-clamped position and the left side showing the closed position securing the product. The clamping block has a 1/16 inch Ultra Strength Neoprene Rubber pad (12) attached to the bottom of it in order to provide friction on the product when it is clamped and indexing the product forward. The channel plate (11) on the bottom is mounted to the base, and has two channels cut in it. These channels are to secure the bottom end of the product when the clamp is forced down by the piston, and are cut to a depth of 1.5 mm to allow for the top part of the product to rest on the top face of the channel plate. This ensures that the product will not be able to change its position during operation. Both plates are made of aluminum, and the channel plate has no coating to provide only a negligible amount of friction if the product contacts it while traveling in the linear guide's return path. Detailed drawings of this channel are available in Appendix A: Indexing and Grabbing Mechanism Drawings.



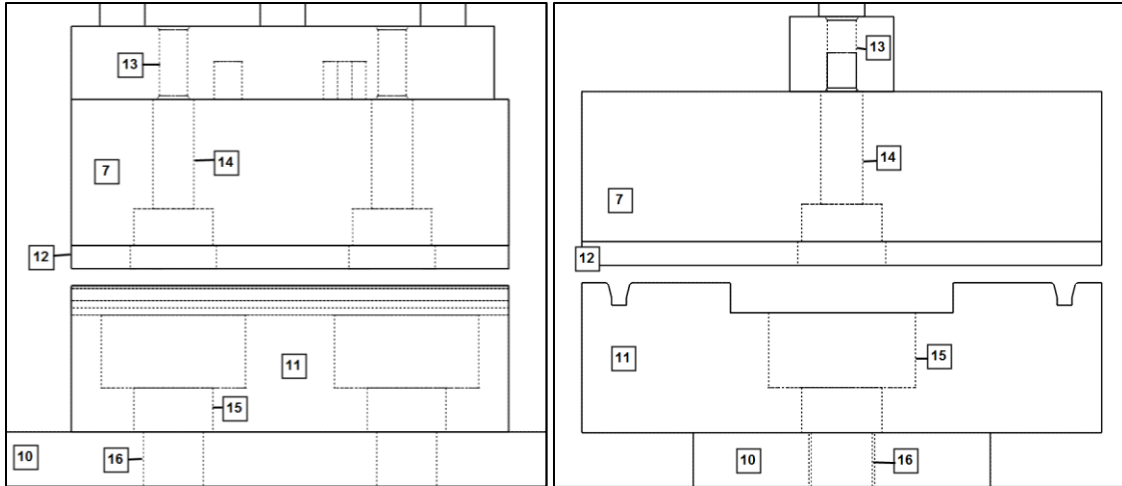

Figure 34: Side (left) and head on (right) view of plate mounting

The positioning of these two plates is controlled by two screws mounted in each one, as shown in Figure 34. The two M2.5 screws holding the clamping block approach through the underside of the clamp and screw into the bottom of the piston arm (13). These mounting holes (14) need to be countersunk in order to make sure that there will be no metal contact between the top and bottom plates. The two screws securely locate the gripping plate. The channel plate (11) is designed so that the two channels holding the product are equal distances from the center of the clamping plate, which eliminates moments on the clamping plate as it holds the product in the closed position. The channel plate has a similar mounting setup, except that the mounting holes (15) allow the screws to join directly into the base (16). The screws used for this mounting are size M5, which is a little larger than the size used for previous mounting operations, as it is not necessary to use the small size that was already pre-tapped into the piston housing. In the middle of the channel plate was a groove sunk 2 mm lower than the contact face that will be supporting the product. This is to ensure that only the rubber grip will be able to contact the product, and that there will be no interference between the two mounting operations on the top and bottom plates.

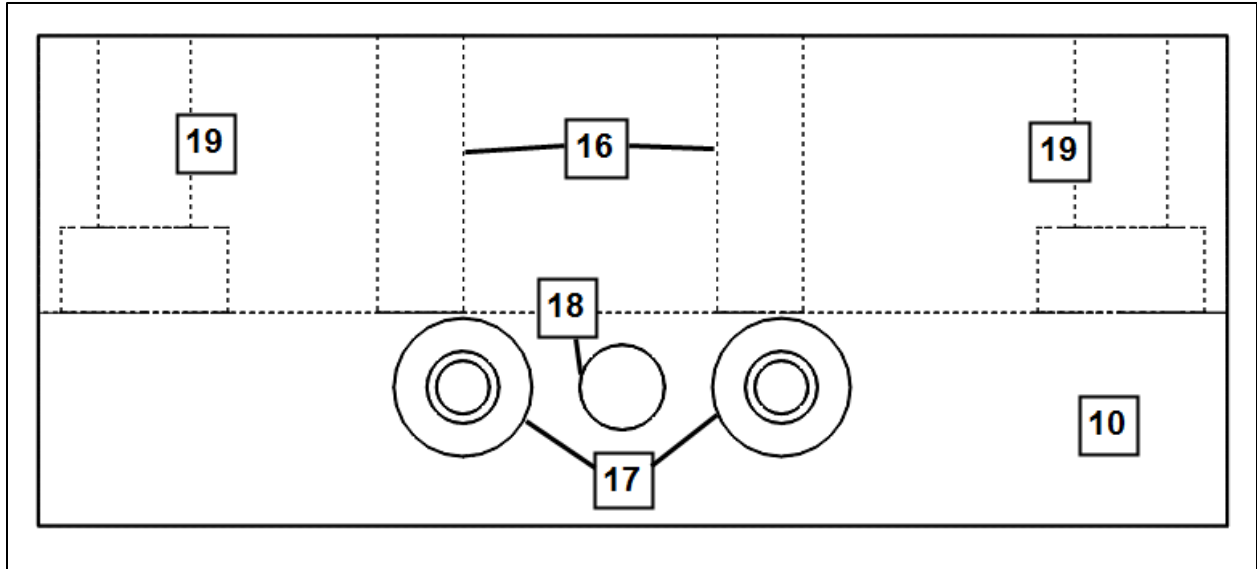

Figure 35: Base

A base was designed to provide for the mounting of the piston assembly to the guide rail of the linear actuator that provides the indexing motion. This base (10) is shown in Figure 35. The base is designed to mount to the guide rail of the linear guide detailed in section 3.1.2 Linear Slide. The channel plate mounts into M5 tapped holes (16), and two countersunk holes (19) are used to secure the piston support to the base.

The base attaches to the linear actuator using the three holes that are in the linear slide's guide. A 4 mm dowel pin is positioned in the middle hole (18) for accurate positioning. Two M3 screws enter from one side of the base (17), go through the guide, and are secured in taps (20) on the other side of the base as seen in Figure 36. This ensures a tight fit that will not loosen during operation.

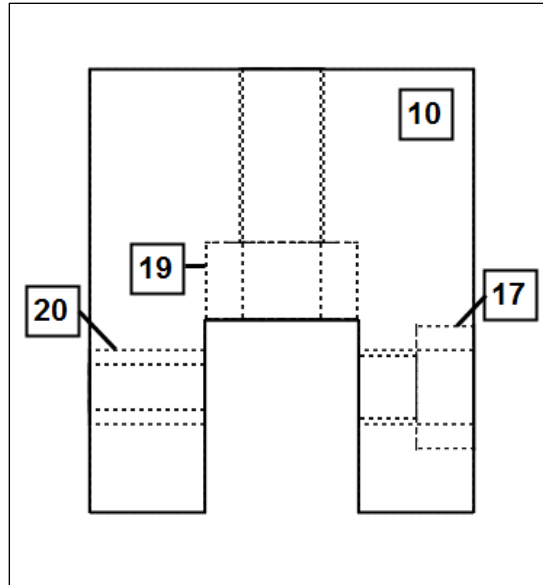

Figure 36: Front View of Mounting Base

This piston assembly meets the need for a compact system that will repeatedly and accurately provide a clamping force while the product is indexed with the motion desired. A piston provides a consistent force and can be tightly controlled using regulators and solenoid valves to make sure that the right air pressure is applied at the right time. Solenoid valves can be activated by a computer system linked with the overall assembly's electronic mechanisms to ensure that the clamping force will be applied exactly when needed and in sync with the movements of the rest of the elements of the overall assembly. A view of the piston grabber assembly in the context of the linear actuator (21) used is shown on the next page in Figure 37.

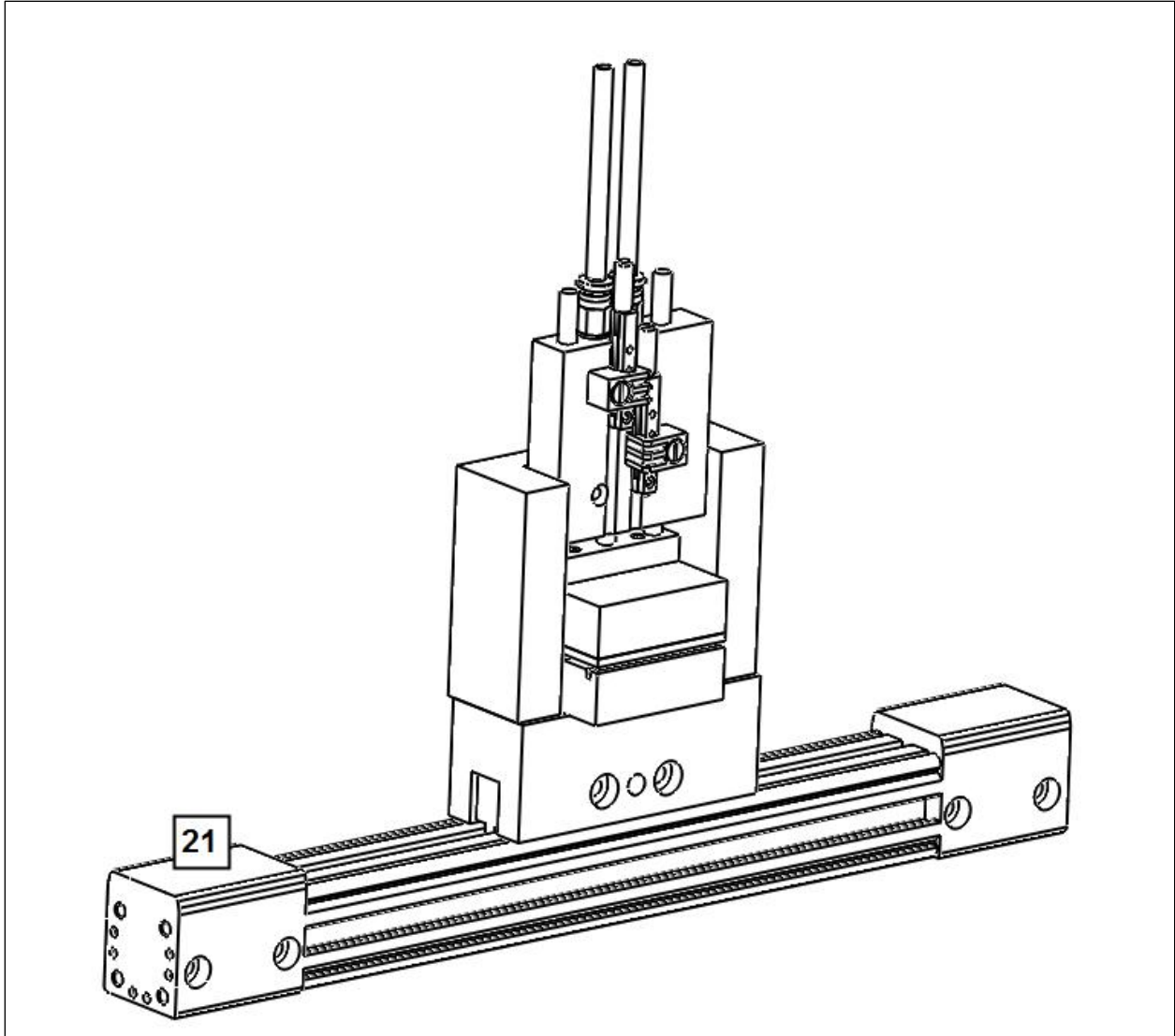

Figure 37: Overall Piston Assembly with Linear Slide

### 3.2.6 Piston Prototyping and Testing

A few values were needed for the design process that could only be found through experimentation. In order to find this information, a prototype test rig of the piston clamber was created. The design used for this prototype was modified from the final design outlined previously, as some of the requirements necessary for the final design were not needed for the

prototype, and also to reduce the cost and time necessary to create it. A SolidWorks model and physical creation of the final prototype design are shown below in Figure 38.

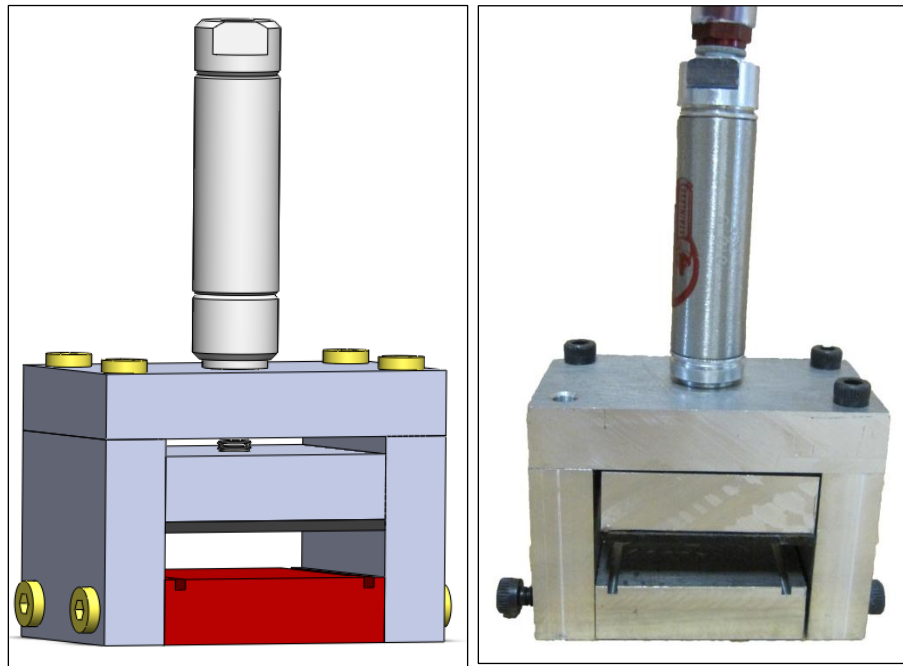

Figure 38: CAD Prototype and Physical Model

The prototype was created using the CNC machines available at Worcester Polytechnic Institute. The fundamental clamping principles remained the same as the final design, but the controlling piston was changed to a Single Acting Bimba Stainless Steel Air Cylinder that was nose mounted using a 3/8"-24 thread. It uses a spring to return to the open position and has a 7/16" Bore and 1/2" Stroke. The channel plate was also modified as the tooling to create the complex groove was not available. Instead of the funnel shape channel of the final design, a 1/16" end mill (the smallest available that could cut through aluminum) was used to cut two channels that were each 1.5 mm deep. While this was different from the final design, it still allowed for the top of the product to overhang the edges of the channel plate and be gripped by the clamping plate when it was closed. Aluminum with a thickness of 3/8" was used for all of the machined parts. This was the closest English unit to the 10 mm thickness that would be used in

the final design. Since the cylinder did not have the same specifications as the one used in the final design there would need to be some conversion after testing to see what air pressures should be used on the piston used in the final design.

There were two goals for testing the piston grabber. The first was to find the ideal Psi to be used in order to provide a firm grip on the product while not damaging it in any way during operation. The second goal of testing was to determine what rubber material should be used to provide the most friction on the product when the piston grabber was closed on it. To accomplish the first objective, a test rig was created to test the fabricated prototype. A pneumatic assembly, shown in **Figure 39**, was designed using a regulator to monitor the pressure used in the cylinder, as well as a manual relief valve that could be used to release pressure in the lines. As testing pressures increased, it was necessary to provide additional bracing at the ends of the tubing to prevent them from being separated from their adaptors as a result of the high pressure. This was accomplished by taping the ends of the tubes to their adaptors.

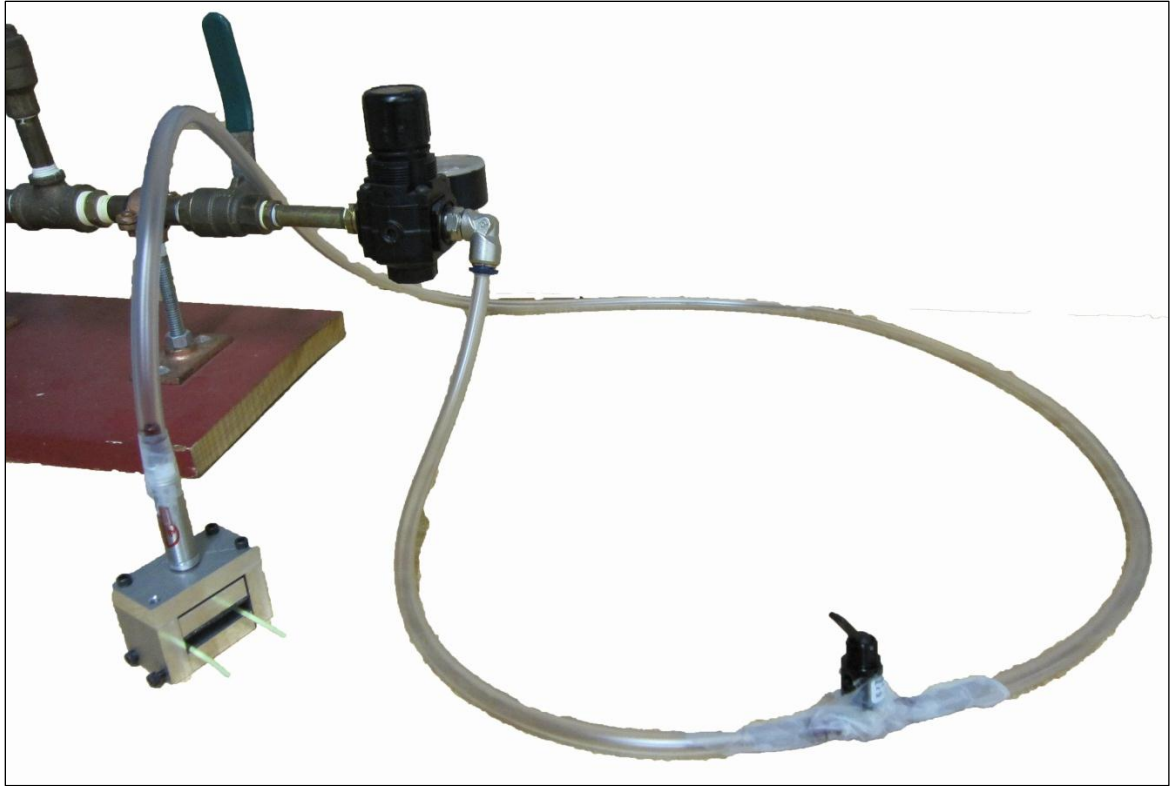

Figure 39: Piston Grabber Test Rig

The pressure value read by the gauges used in the test rig was not the actual force that was being translated to the grabber plate. The test piston had a bore of .4375in, which gives the piston an area of .1503 in<sup>2</sup>. This means that for every 1 psi read by the gages, there was really only .1503 lbf felt by the piston. This led to a conversion unit being found that 6.653 psi=1 lb of force from the piston. The piston was also single acting and had a spring force of 1 lb that needed to be overcome before the piston would extend. This meant that theoretically the first 6.653 psi were used to overcome the force of the spring. This value was found to be accurate during testing of the piston.

To find the maximum pressure allowable, the piston grabber was loaded with product in the channels of the channel plate and activated at various pressures as shown in Figure 40.

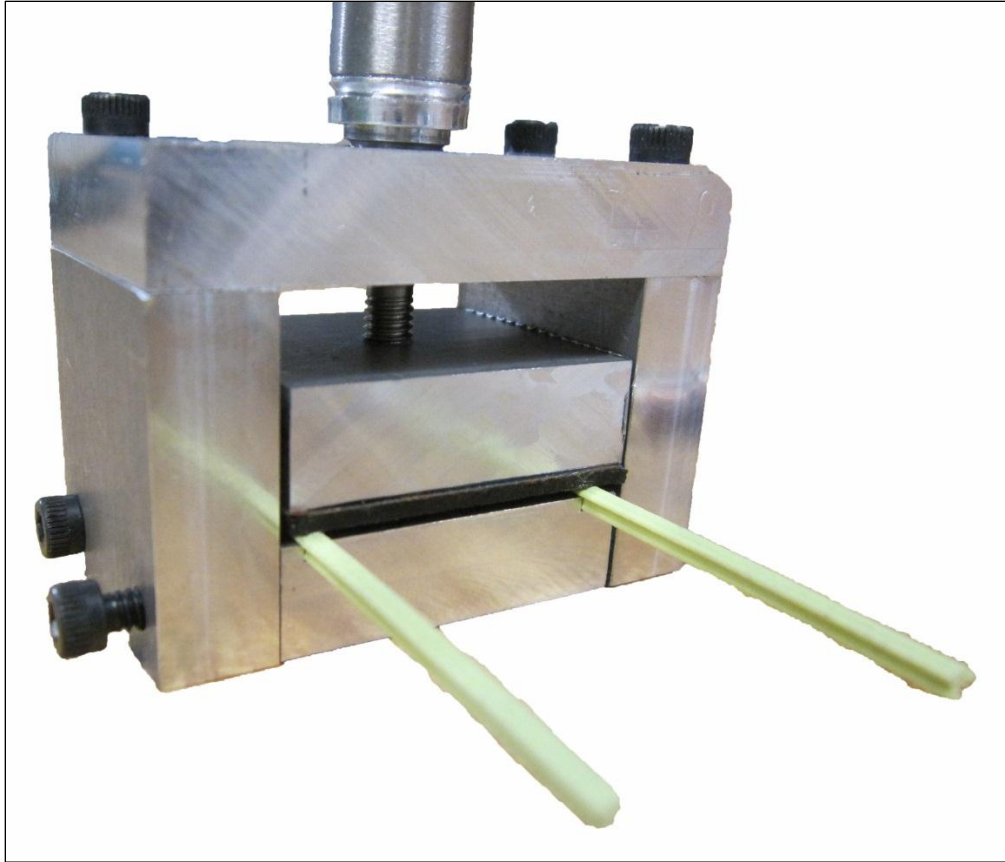

Figure 40: Loaded Piston Grabber

It was found that the max pressure of 120 psi provided by our testing equipment was not sufficient to cause any damage on the product, even when the pressure was applied instantaneously and the piston rapidly closed on the product. The product was then tested by placing it between the two jaws of the piston outside of the tracks and again activating the piston at maximum pressure. No damage to the product was found after this test. Using the conversion factor found before, the equation below calculates the force being applied by the piston.

$$Force = \frac{\text{gauge psi} - \text{psi required to overcome spring}}{6.6653\text{psi/lbf}}$$

The force from the piston was therefore 17.034 lb. Under these conditions, it was impossible to slide the product out of the jaws of the grabber using any amount of force from our hands. The rubber attached to the piston for this test was Ultra Strength Neoprene Rubber P/N 8463K411



from McMaster-Carr. This rubber had an adhesive backing which was used to keep it attached to the clamping plate.

The piston was then tested to see what the minimum psi was where the product would begin to slip from the jaws of the piston grabber. By gradually decreasing the pressure in the cylinder and applying a firm steady force in line with the clamped product, it was found that pressures lower than 35 psi began to allow the product to slip. Using the same formula as before, the force exerted by the piston at 35 psi was found to be 4.25 lb.

In order to apply this data to the final design, it was necessary to find what pressure would be needed for the Festo piston to generate similar forces. The Festo piston has a bore of 6 mm, which is approximately 0.236 inches. Therefore the piston has a bore area of  $\pi \cdot 0.118^2$ , which is  $0.044 \text{ in}^2$ . Using this value, to generate one pound of force it would be necessary to have air at 22.81 psi in the piston. If the Festo piston had been used in our testing at 120 psi then it would have generated 5.26 lbf on the product. While not as much force is applied as for the piston used during testing, this value is above the minimum required to maintain a firm grip on the product.

A variety of different rubber materials were purchased to be tested in order to see which offered the best gripping power. Testing was done using the same procedure above, where a decreasing pressure was applied to the piston while a steady force was exerted on the product in the direction of product flow. Once the product began to slip, the psi in the piston was recorded and then the MPFBS (Minimum Pound Force Before Slip) was calculated. The results of this testing are shown below in Table 2

Material	Ultra Strength Neoprene Rubber	High Strength Multipurpose Neoprene Rubber	Medium Strength Neoprene Rubber	Quick-Recovery Super-Resilient Polyurethane Foam
PSI	35	40	40	42
MPFBS	4.2	5	5	5.3

Table 2: Rubber Testing Results

The material that offered the highest friction to the product was Ultra Strength Neoprene Rubber. It was therefore chosen to be used in our final design. It is not recommended that the sponsor use any pressure lower than 90 psi, which yields a force of 3.9 lb from the Festo Piston. The product has been tested to withstand a force of 17 lb from the piston, so the highest psi available should be used in the pistons operation.

### 3.3 Shuttle and Track Development

The problem of merging two product streams into one output was a challenge that resulted in several concepts before the final design. The basic parameter surrounding the design of this merging process was that both lines of product, which were separated during the splitting phase and cut during the slicing phase, had to be inserted into the load head. It was decided that the most efficient method of completing this would be to combine the two streams during the insertion into the load head. This removes the requirement of propelling the resulting singular stream at twice the velocity of the other streams.

#### 3.3.1 Air-Jet Injection

During the preliminary design process, there were several ideas which were not additionally considered, but an example of one will be introduced here. The air-jet injection

concept is one of the merging processes that was conceived but was not further developed due to critical design flaws. A preliminary picture of the air-jet injection concept can be seen in Figure 41.

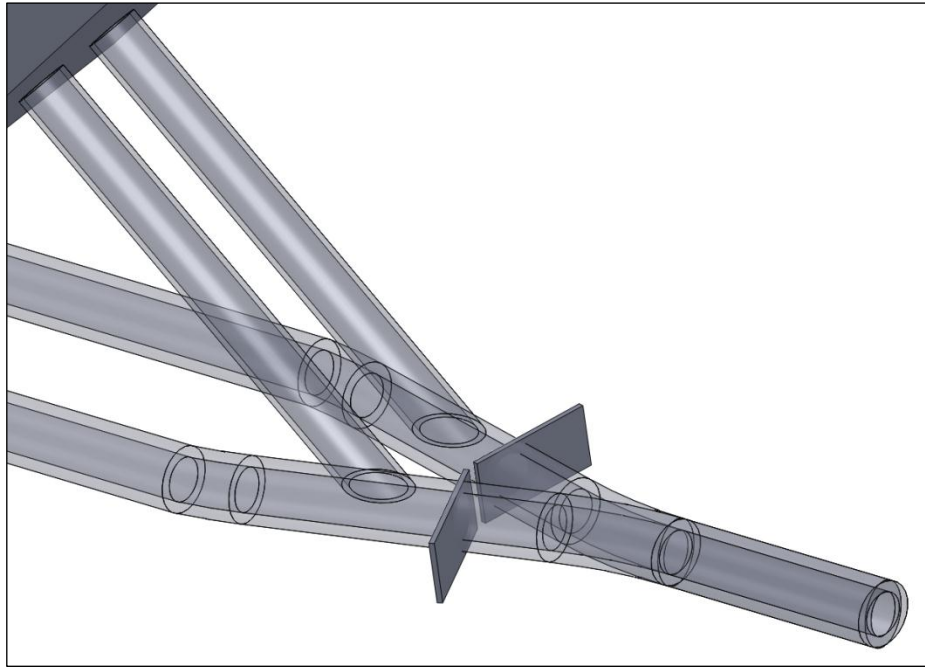

Figure 41: Air-jet Injection Concept

This concept used pressurized air and escapements as a method of merging the two parallel lines of product. The flow in the figure is from left to right. Coming in through the lower tubes are sliced and cut products. The two rectangles intersecting the tracks represent escapements which would prevent unwanted products from going forward. These escapements were opened in an alternating fashion and the tube coming from above to its respective gate would activate and blow pressurized air, motivating the strip to index forward into the single merged track. By completing this in an alternating fashion, the two product lines would be joined and create a single track moving twice as fast.

There were multiple flaws in this design. The tubes which the product flowed through did not provide any rotational support for the products, and as such gave it multi-axis freedom. This

is not desirable, and if a track was incorporated in place of the tubes, the merging section of the track would possibly deform the product or jam. Also, each of the products in the merged flow would rely on the one behind it to push it forward. This in turn meant that the air jets would have to push the entire merged flow, which is very impractical. This preliminary concept in addition to several others was discarded due to impracticality and design flaws.

### 3.3.2 Tommy Gun Concept

Two primary methods of solving the merging problem were developed: the “Tommy gun” concept and the “shuttle” concept. The Tommy gun concept was developed in the preliminary design phase of this project. An image of the assembly can be seen below in Figure 42.

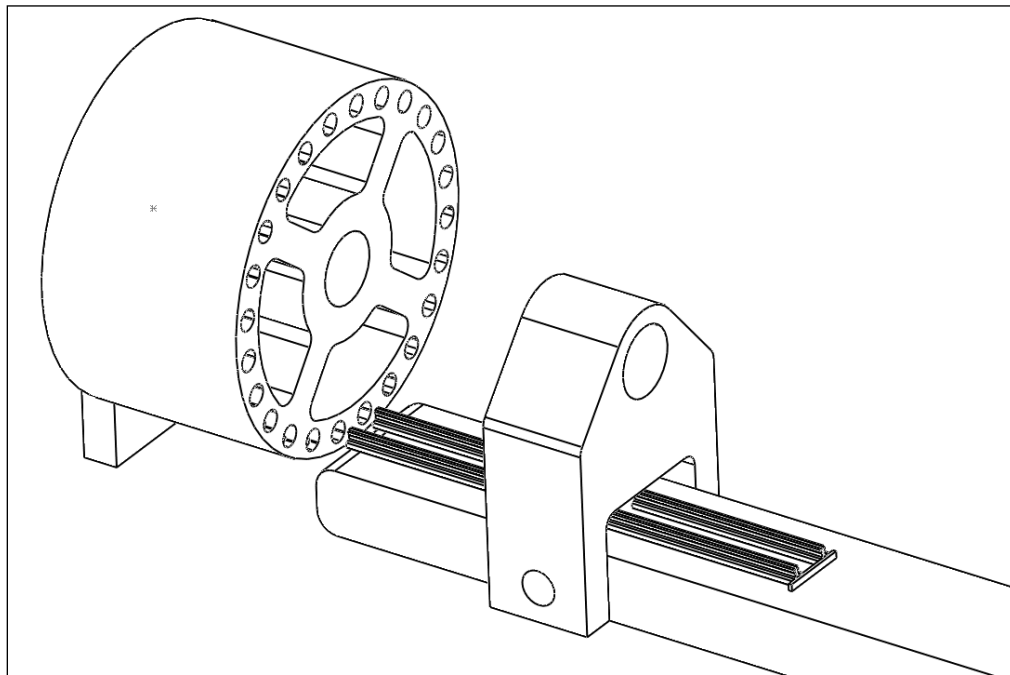

Figure 42: Tommy Gun Concept

The fundamentals of this design were that a servo motor would turn the drum (cylinder with tracks) a predetermined number of times per minute, each time lining up the next section of

track to be blown into the load head with an air jet. There were 24 tracks on the drum, so each rotation was of 15 degrees. Every 30 degrees, two more product pieces would be indexed into the tracks of the drum. Due to the angled orientation of the tracks on the drum, the two tracks of product would not line up perfectly. To aid in the insertion of the product into the drum, the tracks on the drum were created using a sweep: a circle that gradually changed into the correct track profile and orientation. This would be very hard to manufacture with anything short of a mold. The drum would need to be manufactured out of aluminum in order to minimize weight and ease machining. Minimizing the weight of the drum was a very important step, because in order to index the drum at the required speed, large accelerations were needed. The Tommy gun design did not develop far enough into the concept to elaborate on methods of inserting the product into the drum channels. A grooved belt and vacuum pumps were both considered. Belts can be impractical at high speeds for precise manufacturing processes, as they can vibrate easily and have to be fixed to a track for precision. The vacuum method of pulling the product into the tracks would be accomplished with stationary tubes in line with the tracks that the strips are inserted into. This concept could be temperamental, however, and must be tested to ensure the success of the desired process. The vacuum idea ended up being carried over into the next design (shuttle mechanism).

Although there could have been complications in the manufacturing of such a part, this idea was presented to the sponsor during an interim presentation. The resulting consensus was that, although it was a good concept, the design was too close to the current machine in use by the sponsor. This was purely coincidental, as the design team was not informed to the current merging mechanism so that our ideas could be novel. As a result of this meeting, the next section of our design began with a complete redesign of the merging assembly.

The redesign process resulted in the creation of the shuttle mechanism. The shuttle mechanism was influenced through the recommendations of our liaisons to create the simplest design that will accomplish the necessary goals. The shuttle mechanism can be seen below in Figure 43.

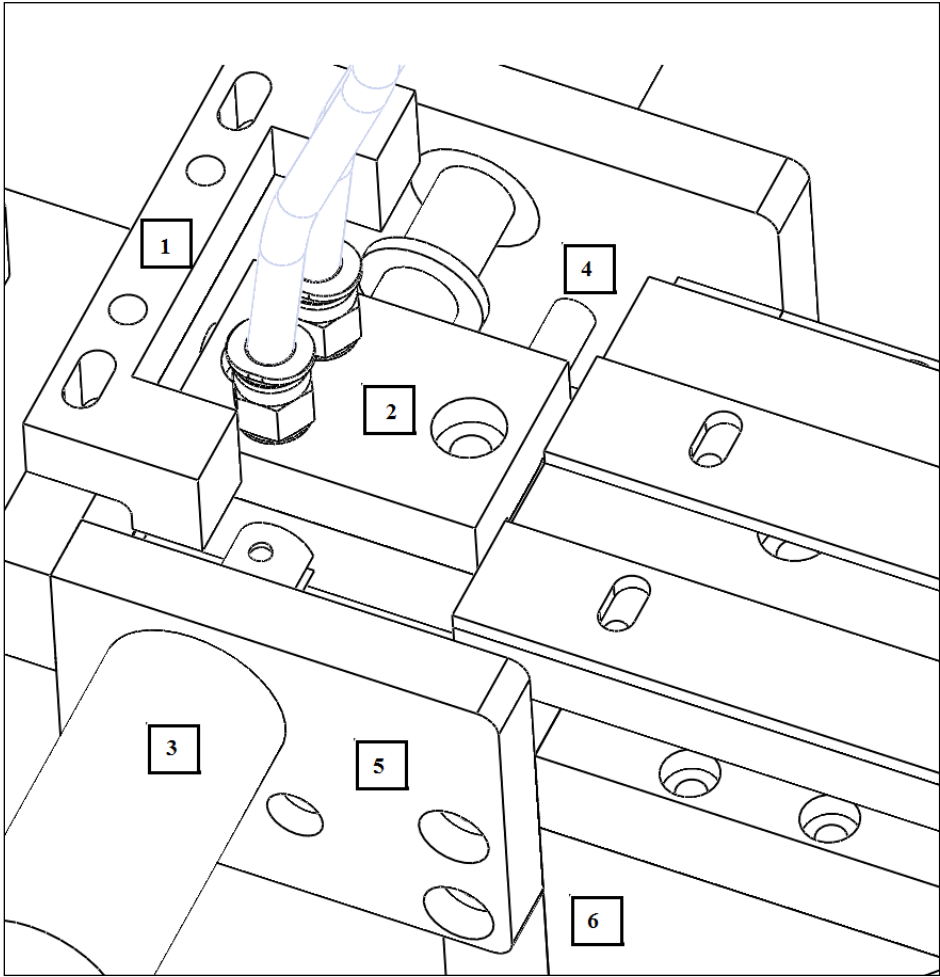

Figure 43: Shuttle Assembly Top View

The purpose of the shuttle mechanism is to focus the two lines of cut product into the load jaws. There are several aspects of the mechanism that must be realized in order to successfully create it. To keep up with the rate that the load jaw inserts the product, a product must be placed into the load jaws at a predetermined rate. At this point, several operations are occurring. The shuttle uses a vacuum pump to suck a product into one of its tracks, and an air jet

to shoot a product out of the other track into waiting jaws. There may need to be a small tube between the shuttle and the jaws due to clearance issues. These two happenings occur simultaneously. After an estimated pre-set time, which is determined by the speed of the solenoids, the shuttle toggles to its other position. At this other position which is currently placed in a location 15 mm perpendicular to the track direction, the track which ejected a product will now be accepting one, whereas the track that just accepted a product will expel it into the load jaws.

Currently, solenoids (3) are used to propel the shuttle axially. Solenoids are placed on either side of the shuttle, so that a current may be applied to the correct side and pull the shuttle against a stop (1). The benefits of using solenoids in this application are that they are fast, accurate if pulled to a stop, and only require the solenoid pins as moving parts. Ledex Long Life Solenoids are an option for this application. The time that the solenoids will be active has to be determined experimentally for accurate results, but an estimate can be determined using a speed vs. stroke diagram provided by Ledex. It is seen below in Figure 44.

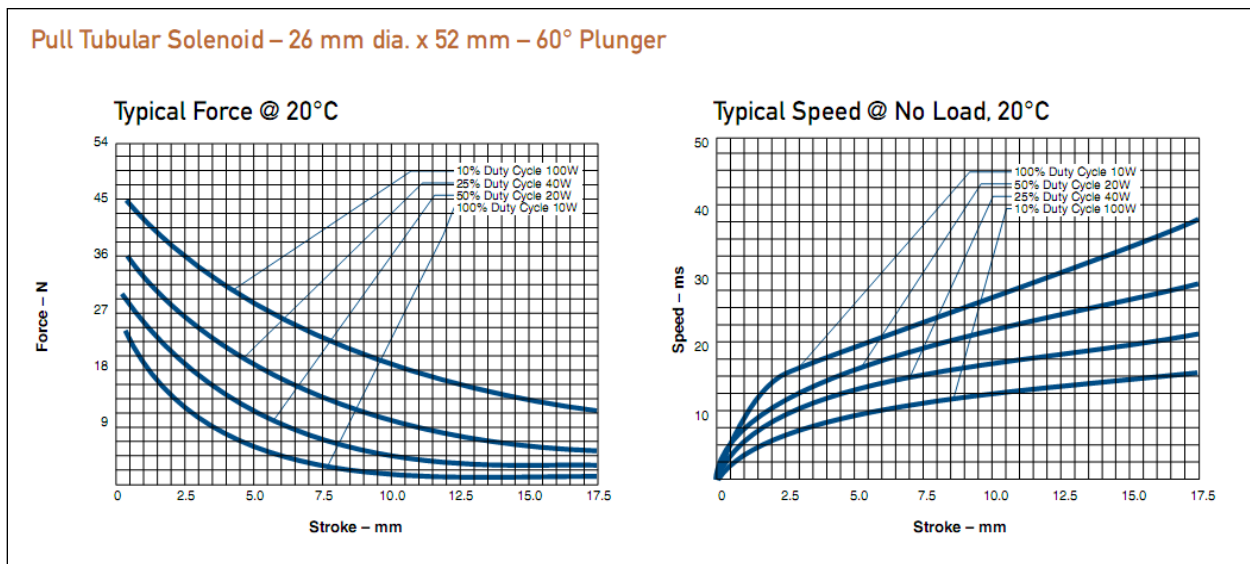

Figure 44: Ledex Solenoid Force and Speed Vs. Stroke Charts

The speed at which the movement is completed with no load is shown above. The load being applied to the solenoid is only the weight of the shuttle and the other solenoid's pin. This weight is dispersed through two bearings on rails, which will reduce the friction, but using the force equation  $F=ma$  and an estimated force as a function of stroke in the left graph of Figure 44, an estimate of the time required to pull the shuttle will be completed. With a shuttle assembly mass of 193 g and a solenoid pin mass of 45 g, a total mass of 238 g will be pulled by the solenoid. The force applied to this mass will be estimated as 12 N from the graph in Figure 44, even though the force will increase as the pin gets closer to its home position. The resulting acceleration is  $50.42 \text{ m/s}^2$ .

$$\begin{aligned}
 x &:= .015\text{m} \\
 a &:= 50.42 \frac{\text{m}}{\text{s}^2} \\
 t &= \frac{x}{v} \\
 v &= \frac{a \cdot t}{2} \\
 t &= \sqrt{\frac{2 \cdot x}{a}} \\
 t &= .024\text{s}
 \end{aligned}$$

This result is an estimate for two reasons. The force that is accelerating the mass of the shuttle and pin will be decreased by the weight of the shuttle and pin multiplied by the friction coefficient of the bearings on the rail. However, this cannot be determined in the scope of this project and will as such be assumed as negligible. In addition to this assumption, it was determined earlier that the force at the outermost part of the stroke would be used, despite there being more force as the pin is pulled into the solenoid.

Despite the possible inaccuracies in this value, it is proven that the time required for the shuttle to travel will be a fraction of the time provided between products being inserted into the



load jaws. In addition to this, the solenoids are shown to have a duty life below 10%, which was estimated for force and acceleration calculations. Using the estimated time calculated above, the duty cycle for the solenoids is roughly 5%, as they alternate activating.

A prototype was manufactured to determine how long the travel time of the shuttle is before it reaches the stops. This prototype included an equivalent mass of the shuttle with linear bearings press fit into it and bearing shafts and a solenoid attached to mounting plates. Due to available facilities, the solenoid could only be tested to the 25% duty load cycle. This required 40 watts of power. To test it to its full capabilities, a power supply able to output 100 Watts would be required.

A Dytran accelerometer was fastened to the prototype assembly to note the impulse of the solenoid starting its pull and hitting its stops. Using LabView, the data was graphed and tabulated. By finding the difference in time between the jump at the start of the pull and the solenoid hitting its stop, the time required to pull the shuttle could be determined.

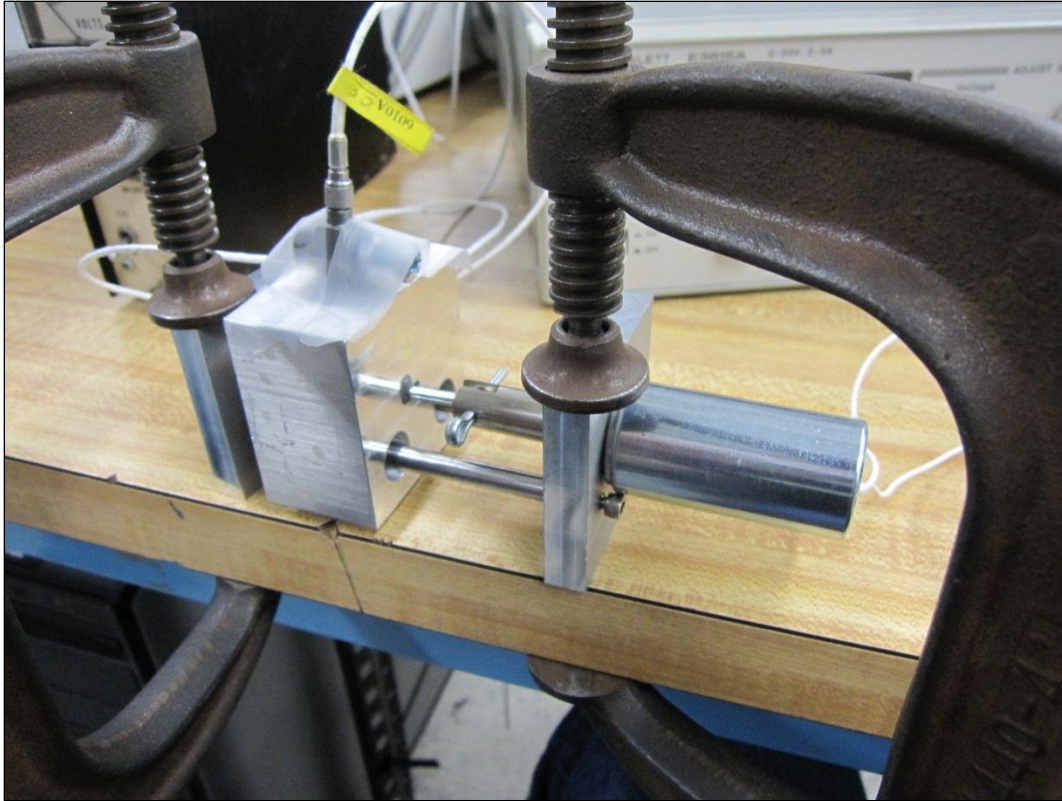

Figure 45: Solenoid Test Assembly

The test assembly can be seen in Figure 45. The accelerometer was placed on top of the mass, and was taped to prevent damage to the accelerometer. A multitude of tests were completed, and the range of time it took the solenoid to decelerate varied from .07 seconds to .11 seconds. A graph of time versus acceleration amplitude is shown in Figure 46.

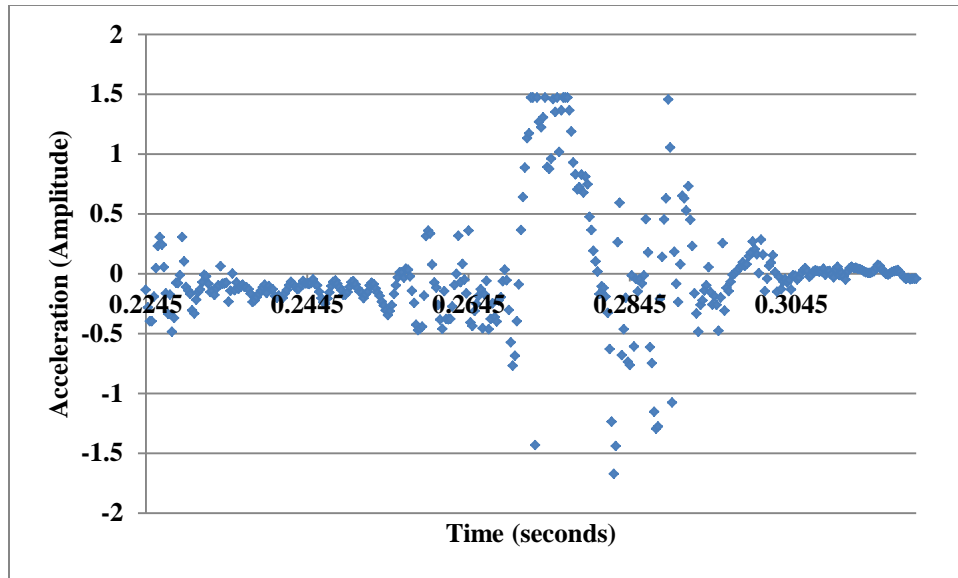

Figure 46: Acceleration of Test Shuttle Mass

The y-axis values are not important, as the only information needed is when the acceleration begins and when it settles again around zero. The acceleration represents the current being applied to the solenoid and the settling represents the shuttle post-movement ready to accept or eject the product.

The values obtained through this test are different than the predicted results for several reasons. The solenoid pin was not exactly concentric with the body of the solenoid due to a machining error, so this added additional unnecessary friction. There was also extra friction between the bearings on the shuttle block and the bearing shafts. This was due to a slight misalignment in the manufacturing of the support plates. The testing of the solenoid at the 25% duty cycle also resulted in a smaller pulling force than can be expected with the settings of the 10% duty cycle. These settings can be seen in Appendix E: Product Data Sheets.

The aluminum shuttle (2) is composed of a top and a bottom for manufacturing purposes. These two pieces are joined by a pair of M5 socket cap screws. In the bottom half of the shuttle, two bays are bored out to accept 6 mm VXB bearings that are press fit into the aluminum piece.

Two custom eyebolts also have to be manufactured and tapped in order to screw into the side of the shuttle. The purpose of these two custom eyebolts is to secure the Velmex solenoids to the shuttle. Two tapped side plates secure the solenoids axially (5). Two steel bearing shafts (4) kept the shuttle on the correct path. The ends of these shafts are tapped and have closely toleranced holes to ensure parallelism to a close degree. The two side solenoid plates are attached to a base plate (6), which is grounded to one of the two mounting planes. The holes in the mounting planes use dowel pins for positioning and socket cap screws for securing.

In order to move the product from the two input lines to the output line, they must be moved from their tracks into the shuttle in a fraction of a second. A vacuum pump is employed to complete this function. The sponsor informed the group that there is a vacuum line running along the assembly line and it may be used for this application. The vacuum lines will attach to the shuttle using Festo M5 vacuum fittings, a standard part used by the sponsor. The vacuum flow will alternate between the two tracks on the shuttle, turning off when in line with the exit track. A closely toleranced back wall can help prevent some of the pressure difference that will be lost via leakage. The vacuum ports were placed near the rear of the shuttle with sufficient space so that when the product reaches that point and blocks the vacuum port, the product is entirely within the shuttle.

When the product within the shuttle aligns with the track exit, an air jet is used to shoot the product into the waiting load jaws. An air jet like this is currently in use by the sponsor, and only slight modifications should have to be made to adapt it to this mechanism.

The most complex aspect of manufacturing the shuttle is the track that the product travels in. An alternative iteration that was not selected due to manufacturing complications is shown below in Figure 47.

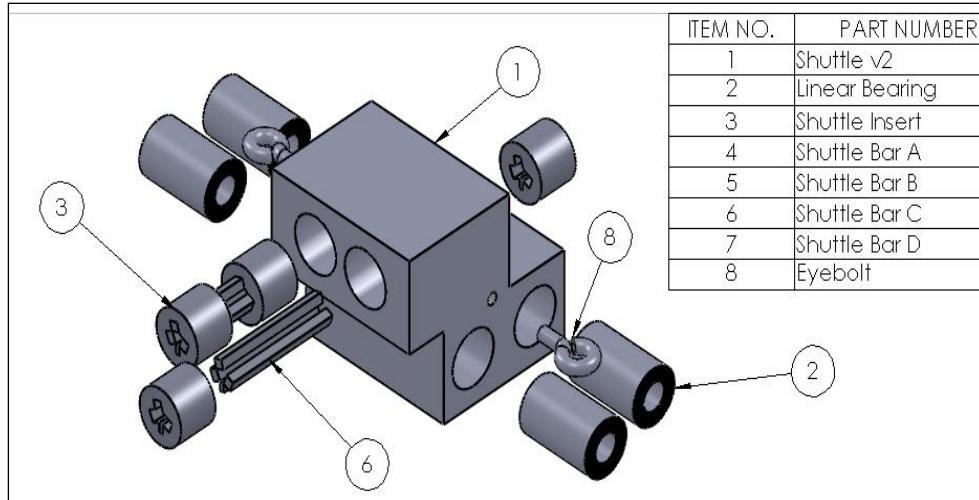

Figure 47: Alternate Shuttle Track Iteration

Due to the manufacturing options at Worcester Polytechnic Institute, the group initially believed that it would be easier to manufacture an acrylic track profile using two laser cut profiles (3), joined by track rods (6). This may have been an easier manufacturing alternative if the parts were larger, but the rods were only 1-2 mm<sup>2</sup> in cross-sectional area. This made the manufactured acrylic warp when cut with lasers. Fortunately, the manufacturing test was carried out before a final design was selected and as a result the other iteration was decided upon.

The tested track profile can be seen as modeled and manufactured in Figure 48 and Figure 49, respectively.

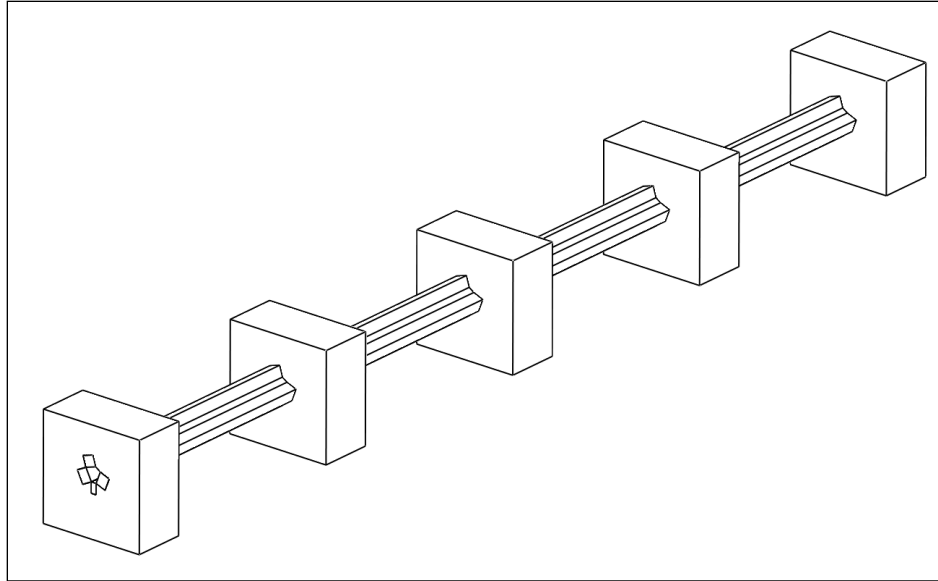

Figure 48: Model of Alternate Track Design

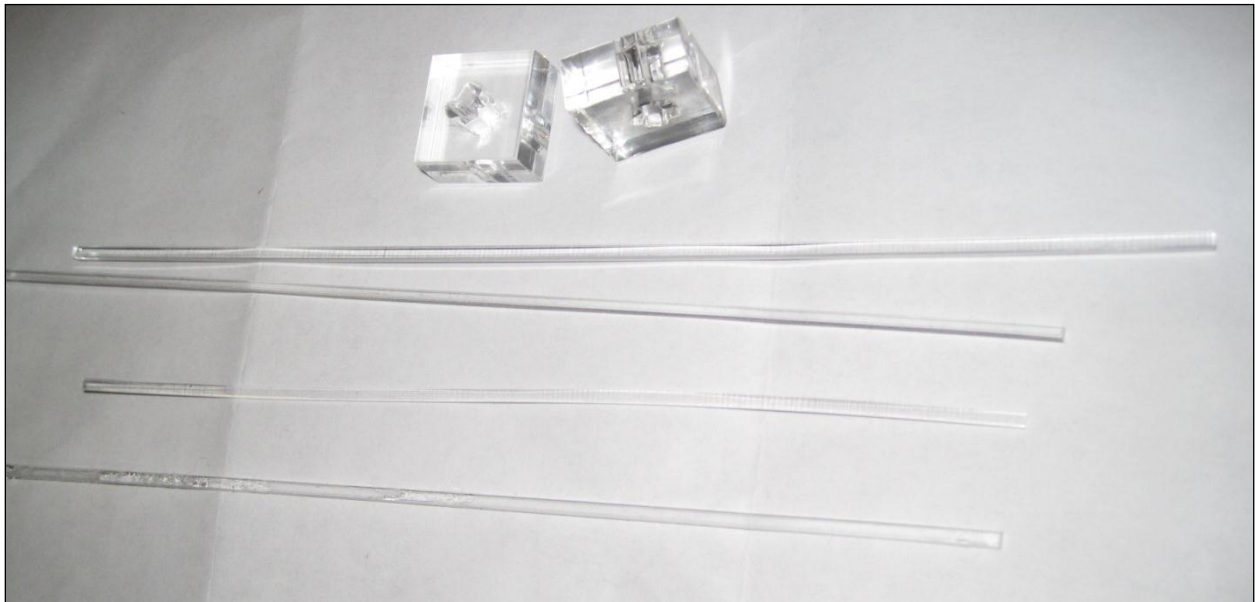

Figure 49: Alternate Track Design Manufactured Parts

In Figure 49, the warping of the rods is visible. The track profiles, which are the two blocks, also had large tolerance differences between one another. As a result of these manufacturing errors, the track shape could not be tested, but it was determined that this track design could not be selected for the final iteration.

The profile of the track was developed using several design parameters. There are requirements that the track must fulfill: geometry to prevent the product from leaving the track, the pushing forces on the product must be well distributed so that the product does not deform, and the orientation of the track must allow for the product to be loaded into the load head. One of the most important factors when designing the track was considering how the product would be moved once they were in the track. Since the products were pushed by the ones behind them moving forward, the track was enclosed to prevent buckling. If the track is designed to be pushed by an external source such as a pad, the product must be partly exposed.

The material of the track is important for several reasons. Machinability, cost, and coefficient of friction with the product are the most important factors. Although the product should not jump off the track on its own accord, there are vibrations around the track that may lead to possible jamming. It was decided that in order to maintain the most control over the part, prevent jamming, and ensure the product does not buckle, a mostly-enclosed track would be used. The designed track has a profile as shown in Figure 50.

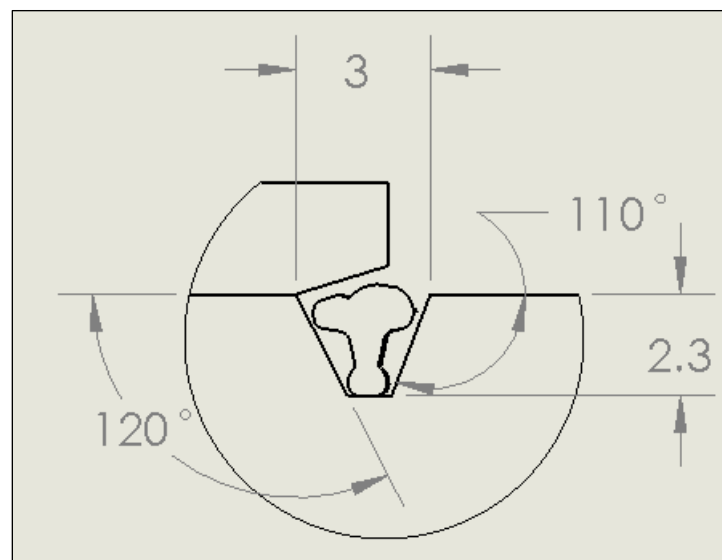

Figure 50: Track Profile (dimensions are in mm)

The tolerance of the track allows the product limited mobility. This was designed into the track profile to account for manufacturing and storage flaws within the product which result in warping and twisting. The slight gap allows the operator of the machine to view where there might be a problem without removing the top cover, yet it is small enough to not allow any of the product to escape the track profile.

Creating the track in two pieces presents several advantages over a single track part. Machining the part is far more manageable when created in multiple parts. After creating the squared plates, a machinist must simply run a tool down the length of the plate, which is fastened at the required angle. For the bottom section of the track, this will be done thrice, one pass for each side of the track, and one to create a flat bottom.

This design also allows for easy access to the product in case of jamming or other problems. There are two possibilities for mounting the top section of the track to the grounded bottom that allows for easy user access to the product within the track. The primary method, which is in our current design, uses slots in the top section of the track. By adding springs under the screw heads, a force is applied holding the plates together but allowing the operator to slide the plate out of its functioning position in order to access the product. A diagram of the track in the closed position can be seen in Figure 51.



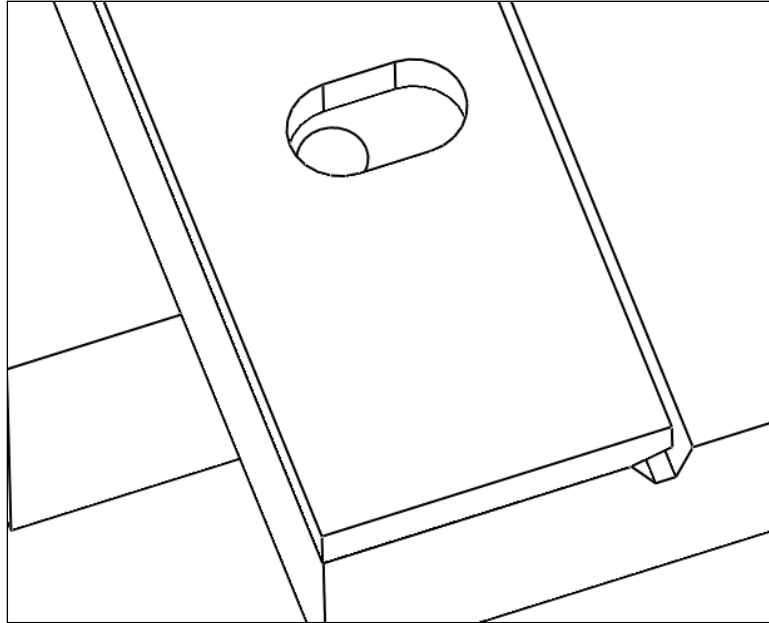

Figure 51: Top Section of Track in Open Position

When there is a jam or error in the product line, the operator simply puts their fingers on the product side of the top track piece and pushes it to the side. The springs will hold it in the position it is currently in, and the resulting position can be seen in Figure 52.

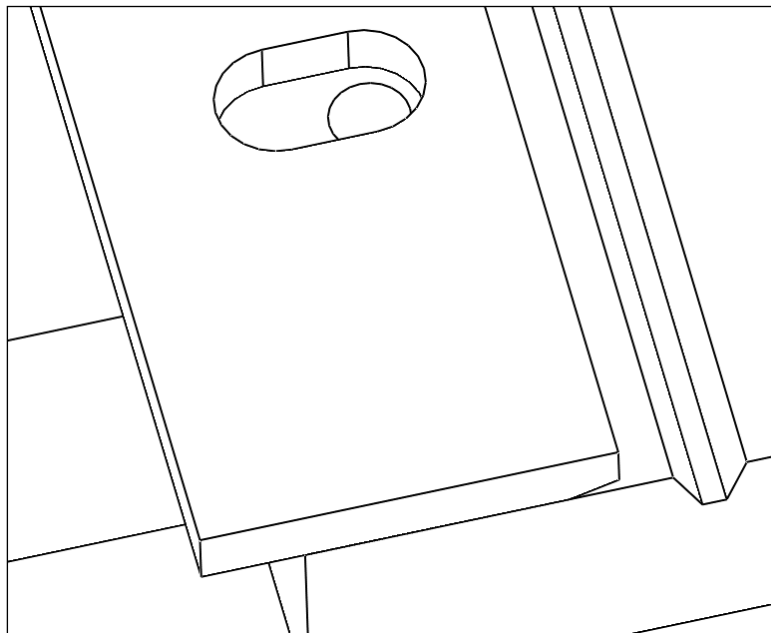

Figure 52: Top Section of Track in Closed Position

Once the track cover is in this position, the error in the product line may be remedied. The holes are M4 sized, and springs have been selected to fit them. Wave springs are the best choice of springs for this application, as they provide very large spring constants with small displacements. Lee Springs' product number LW0310601145 is a wave spring with an OD (outer diameter) of .288 inches, an ID (inner diameter) of just over 5 mm, and a spring force constant of 143 lb/in. Fully compressed, this spring provides about 9 pounds of force. Our design provides for two slotted holes per track cover, so there can be up to 18 pounds of force holding the track in whatever position it may be in.

An alternate method of moving the track cover was having the cover attached to the track base on a hinge. This could provide the operator with a simple operation of unclasping a latch and swinging open the top of the track to view potential problems on the track. However, when designing for this, several problems were encountered. Small enough stock hinges were not found for our application and an offset distance from the top of the track cover to the top of the track base would have to be accounted for on the hinge to maintain flush faces. Latches on a part this small could also break easily and consequently require replacement. This design was scrapped for the simpler sliding track cover after discussion with our sponsor liaison.

## 4. Results

The result of this project is a full assembly combining the individual components designed in order to accomplish the task of moving the product from its reel to the assembly line. This full assembly is shown below in Figure 53.

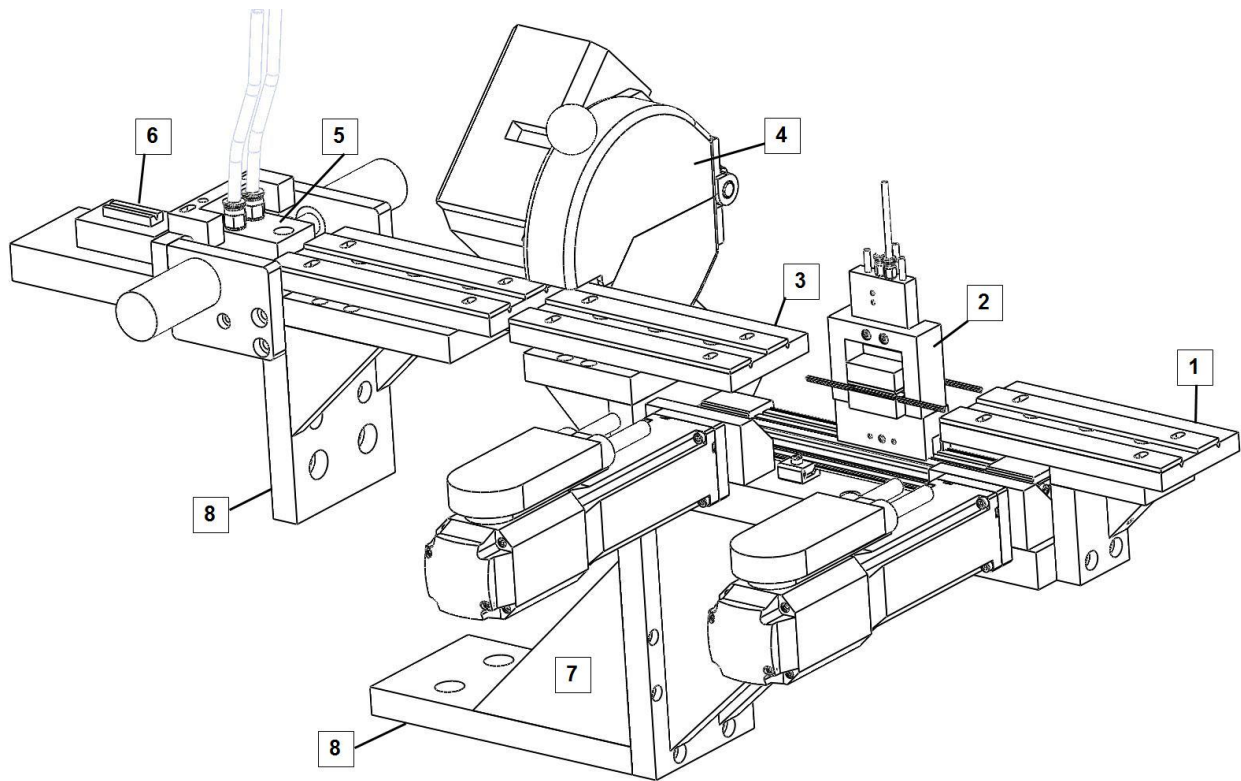

Figure 53: Overall Assembly

The product approaches from the right, having already been split into two streams by an existing part of the assembly line. These two separate strips enter into a track (1) which directs them into the correct orientation. From there the un-cut product lines move across a gap in the track where they are pulled forward by the grabber indexer (2). The product then goes into another track (3) to be cut to the desired size by the cutting mechanism (4). The cutting operation is performed by an automated process already perfected by the sponsor and which was not included in the scope of the project. The cut product then continues through the track, each piece

being pushed by the product behind it, until they come to the shuttle mechanism (5). This mechanism alternates between the product lines and uses a vacuum pump to load each piece of product into the shuttle. Once one side of the shuttle is loaded, the shuttle moves to load another piece of product from the opposite product line. While loading, a blast of compressed air ejects the already loaded product into the assembly line (6).

In addition to the mechanisms that were outlined in the design section, it was necessary to create a means of mounting all of these parts together and connecting them to the existing assembly line. A mounting interface (7) was created once all of the other components were designed, and provides a solid platform for each of the mechanisms. It attaches to the two mounting planes (8) provided by the current assembly line as specified by our sponsor. Detailed drawings of this mounting system are shown in Appendix C: Track and Mounting Drawings.

## **5. Conclusions and Recommendations**

This project brought a mechanically driven system into the current realm of assembly line technology. This was accomplished by changing the design from having individual motions being dependent upon a central drive shaft to each individual process being controlled by servo motors and other electronic components that would be controlled by a computer.

Further research could be done into the overall control system for the assembly line. As it is now, the design is the raw muscles without a brain to guide their motion. This system would control all of the parts of the assembly line, not just the parts designed for this MQP, and would make sure that all components of the entire assembly process acted in sync. This is essential during starting and stopping of the flow of the nest stations, as each component must increase the speed of their operation at the same rate as all the others until the running speed of the assembly line has been reached. A computer system that controls everything is absolutely necessary as a transition is made from a cam driven system to one driven by servo motors. The design of such a system was outside of the scope of this project, but could possibly be done by future groups. However the programming required for such a system would mean that it would be best done by students with a background in computer science.

Other project possibilities could be similar in nature to ours, taking an existing cam driven system and converting it to an automated one using more modern methods of control.

# Appendix A: Indexing and Grabbing Mechanism Drawings

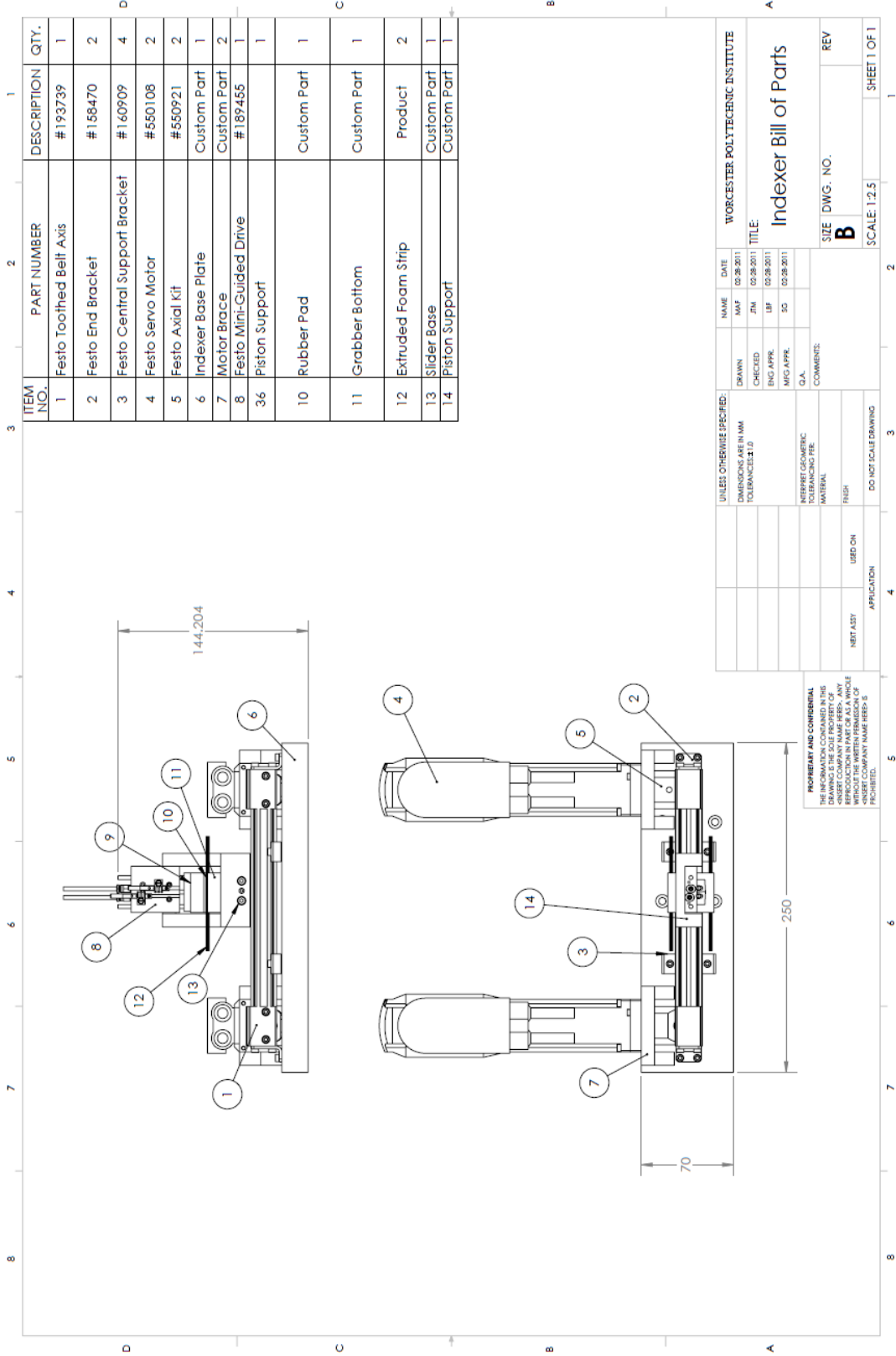

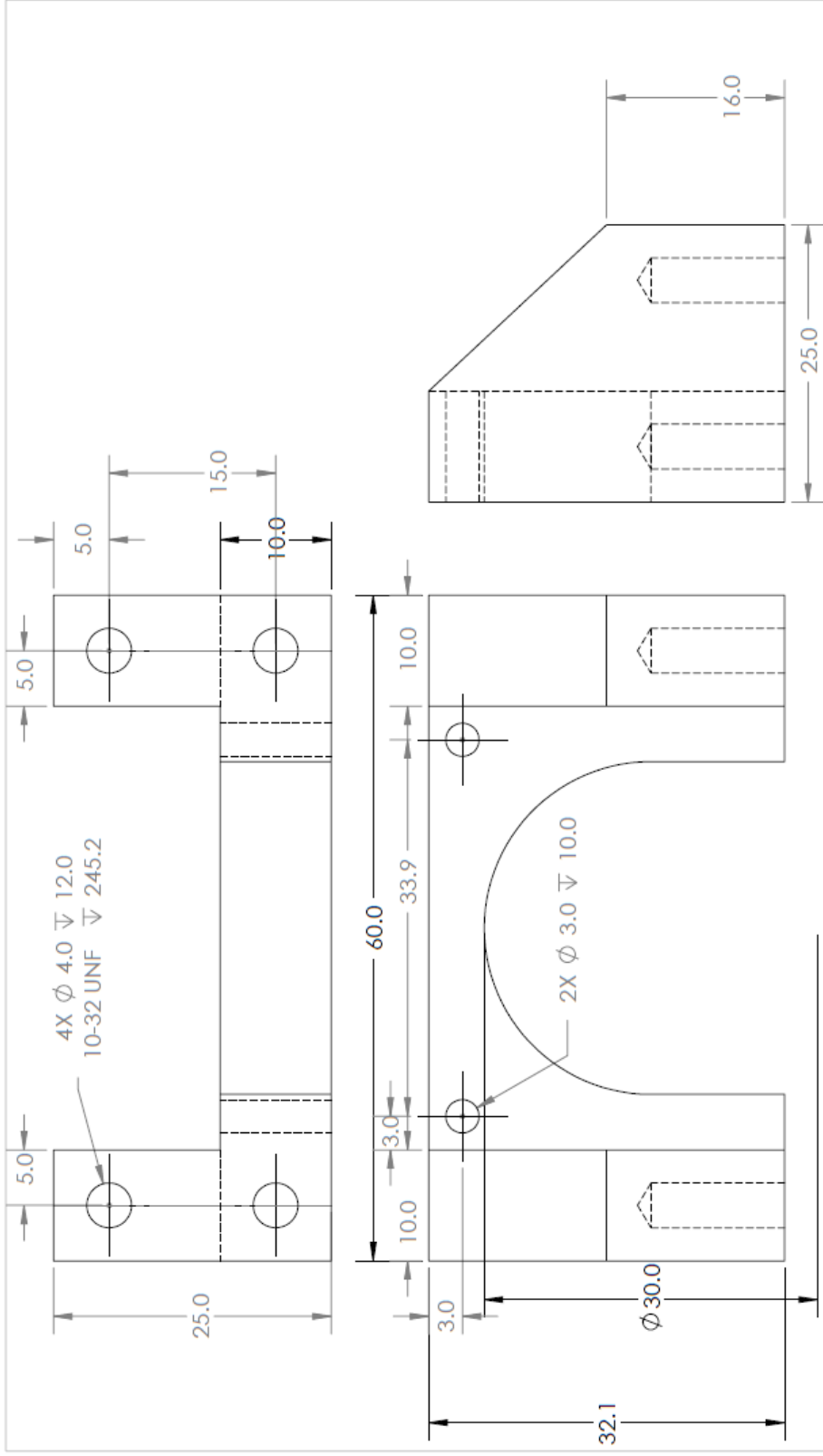

UNLESS OTHERWISE SPECIFIED:		NAME		DATE		WORCESTER POLYTECHNIC INSTITUTE	
DIMENSIONS ARE IN MM		DRAWN	MAF	JTM	02-28-2011	TITLE:	
TOLERANCES: ±1.0		CHECKED	JTM	LBF	02-28-2011	Motor Brace	
INTERPRET GEOMETRIC TOLERANCING PER:		ENG APPR.	LBF	SG	02-28-2011	SIZE	DWG. NO.
MATERIAL		G.A.		COMMENTS:		<b>A</b>	REV
FINISH		ALUMINUM		DO NOT SCALE DRAWING		SCALE: 2:1	
NEXT ASSY		USED ON		APPLICATION		SHEET 1 OF 1	
PROPRIETARY AND CONFIDENTIAL THE INFORMATION CONTAINED IN THIS DRAWING IS THE SOLE PROPERTY OF <INSERT COMPANY NAME HERE>. ANY REPRODUCTION IN PART OR AS A WHOLE WITHOUT THE WRITTEN PERMISSION OF <INSERT COMPANY NAME HERE> IS PROHIBITED.		5		3		1	

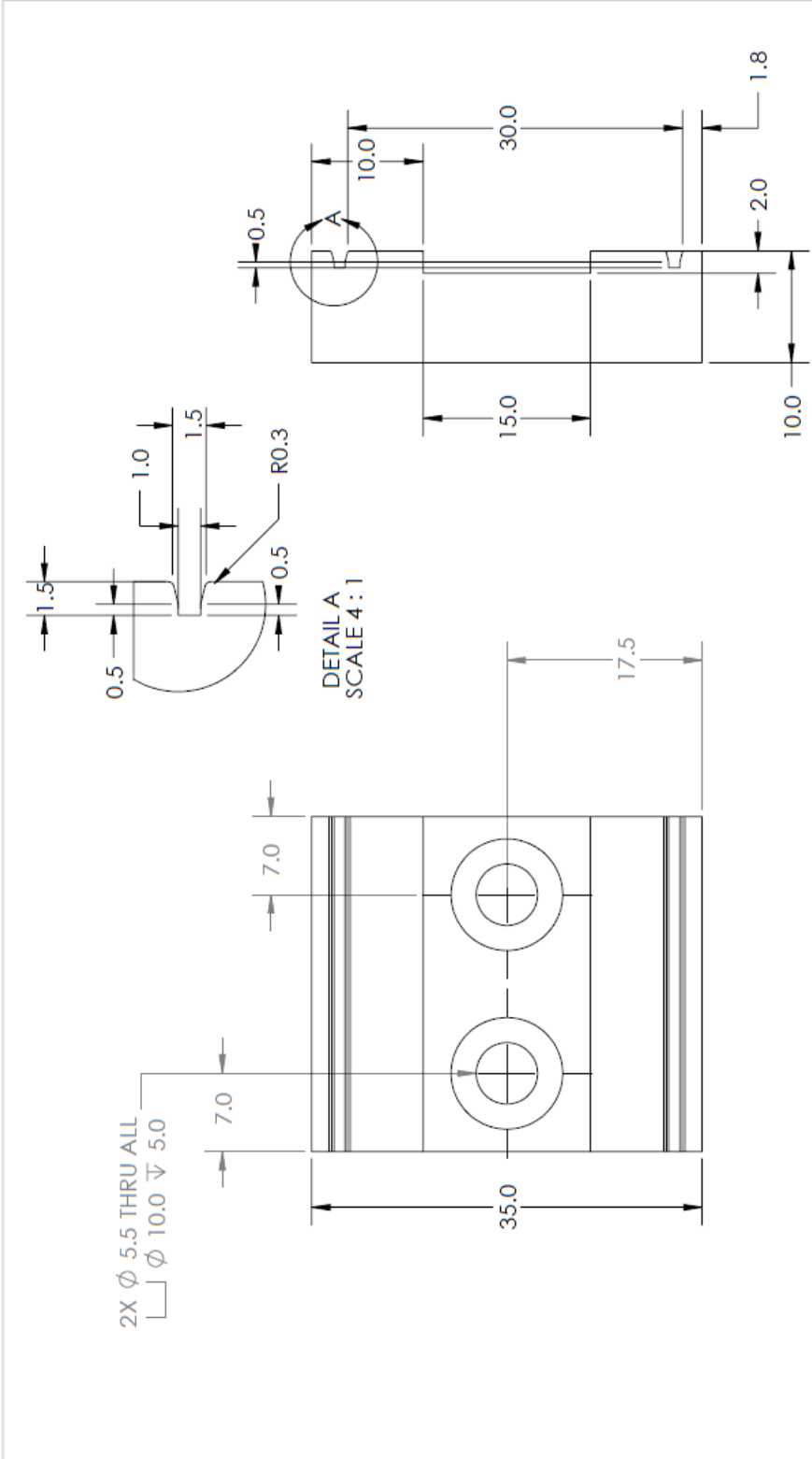

UNLESS OTHERWISE SPECIFIED:		NAME		DATE		WORCESTER POLYTECHNIC INSTITUTE	
DIMENSIONS ARE IN MM		DRAWN	MAF	02-28-2011	TITLE:		
TOLERANCES: ±1.0		CHECKED	JTM	02-28-2011	Grabber Contact		
INTERPRET GEOMETRIC TOLERANCING PER:		ENG APPR.	LBF	02-28-2011	SIZE DWG. NO.		
MATERIAL		MFG APPR.	SG	02-28-2011	A		
FINISH		G.A.		COMMENTS:			
MACHINED							
DO NOT SCALE DRAWING				SCALE: 2:1			
APPLICATION				SHEET 1 OF 1			
NEXT ASSY				REV			
USED ON				1			

**PROPRIETARY AND CONFIDENTIAL**  
 THE INFORMATION CONTAINED IN THIS DRAWING IS THE SOLE PROPERTY OF <INSERT COMPANY NAME HERE>. ANY REPRODUCTION IN PART OR AS A WHOLE WITHOUT THE WRITTEN PERMISSION OF <INSERT COMPANY NAME HERE> IS PROHIBITED.



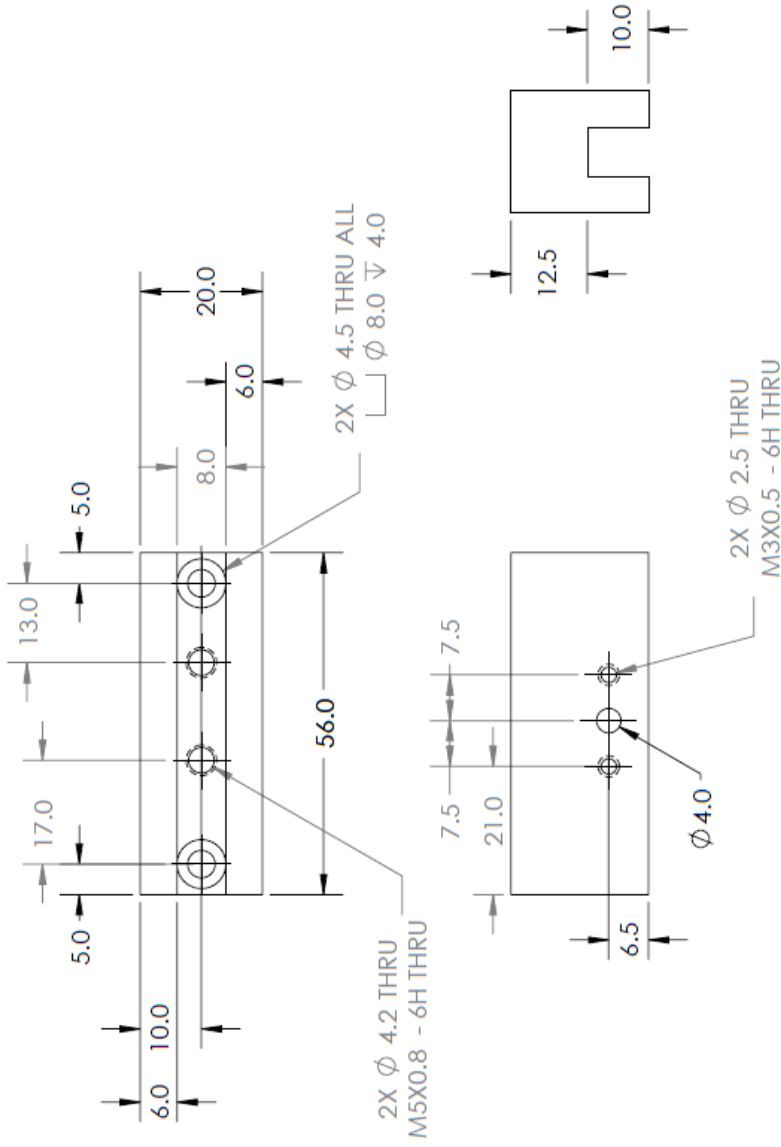

UNLESS OTHERWISE SPECIFIED: DIMENSIONS ARE IN MM TOLERANCES: 1.0		NAME MAF	DATE 02-28-2011	WORCESTER POLYTECHNIC INSTITUTE	
INTERPRET GEOMETRIC TOLERANCING PER:	MATERIAL ALUMINUM	CHECKED JTM	02-28-2011	TITLE: Slider Base	
FINISH MACHINED	USED ON NEXT ASSY	ENG APPR. LBF	02-28-2011	SIZE <b>A</b>	REV
DO NOT SCALE DRAWING	APPLICATION	MFG APPR. SG	02-28-2011	SCALE: 1:1	SHEET 1 OF 1
<b>PROPRIETARY AND CONFIDENTIAL</b> THE INFORMATION CONTAINED IN THIS DRAWING IS THE SOLE PROPERTY OF <INSERT COMPANY NAME HERE>. ANY REPRODUCTION IN PART OR AS A WHOLE WITHOUT THE WRITTEN PERMISSION OF <INSERT COMPANY NAME HERE> IS PROHIBITED.		G.A.	COMMENTS:	2	
APPLICATION		DO NOT SCALE DRAWING		3	
5		4		1	

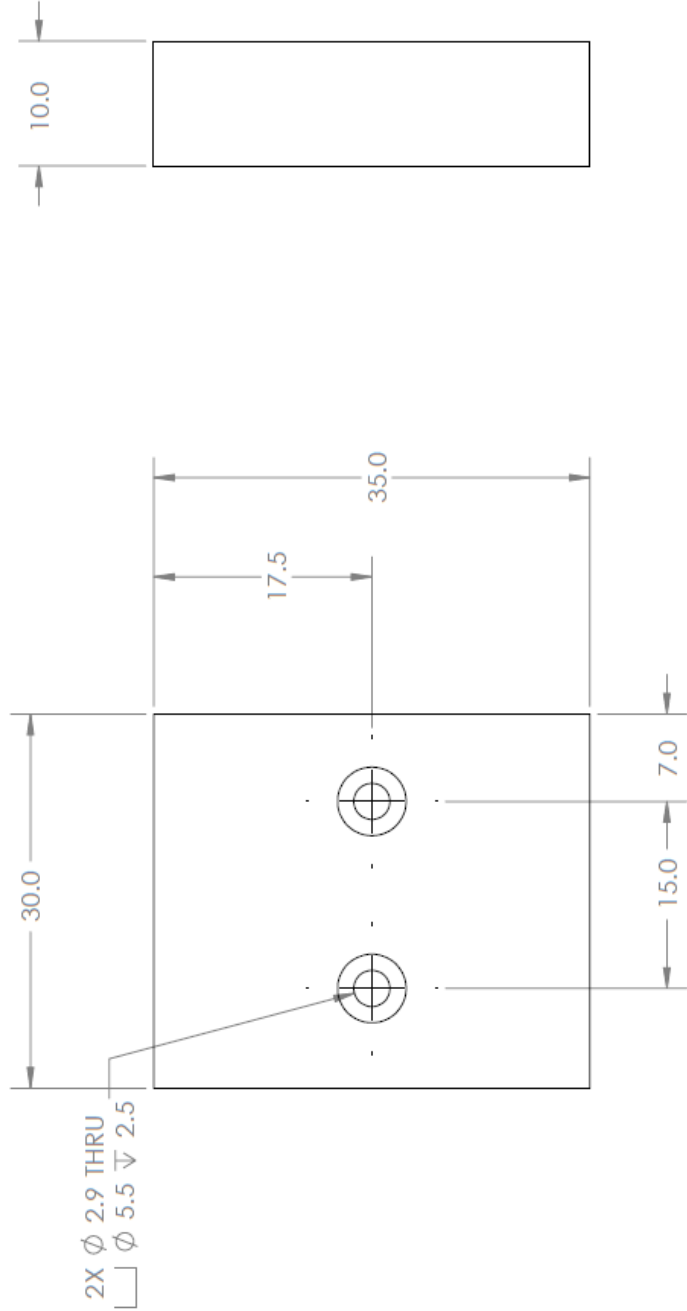

UNLESS OTHERWISE SPECIFIED:		NAME	DATE	WORCESTER POLYTECHNIC INSTITUTE
DIMENSIONS ARE IN MM		MAF	02-28-2011	TITLE:
TOLERANCES: ±1.0		JTM	02-28-2011	Gripper Top
INTERPRET GEOMETRIC TOLERANCING PER:		LBF	02-28-2011	SIZE DWG. NO.
MATERIAL		SG	02-28-2011	<b>A</b>
ALUMINUM		G.A.		SCALE: 2:1
FINISH		COMMENTS:		SHEET 1 OF 1
MACHINED				
DO NOT SCALE DRAWING	3		2	
APPLICATION	4			
USED ON				
NEXT ASSY				
<p><b>PROPRIETARY AND CONFIDENTIAL</b>          THE INFORMATION CONTAINED IN THIS DRAWING IS THE SOLE PROPERTY OF          &lt;INSERT COMPANY NAME HERE&gt;. ANY          REPRODUCTION IN PART OR AS A WHOLE          WITHOUT THE WRITTEN PERMISSION OF          &lt;INSERT COMPANY NAME HERE&gt; IS          PROHIBITED.</p>				

2X  $\phi$  4.2  $\nabla$  15.0  
M5X0.8 - 6H  $\nabla$  10.0

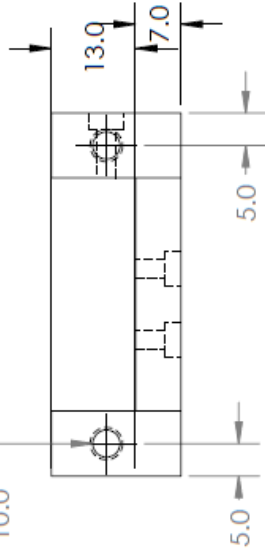

2X  $\phi$  2.9 THRU  
 $\nabla$   $\phi$  5.5  $\nabla$  2.5

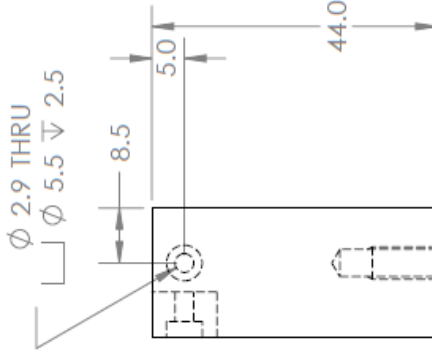
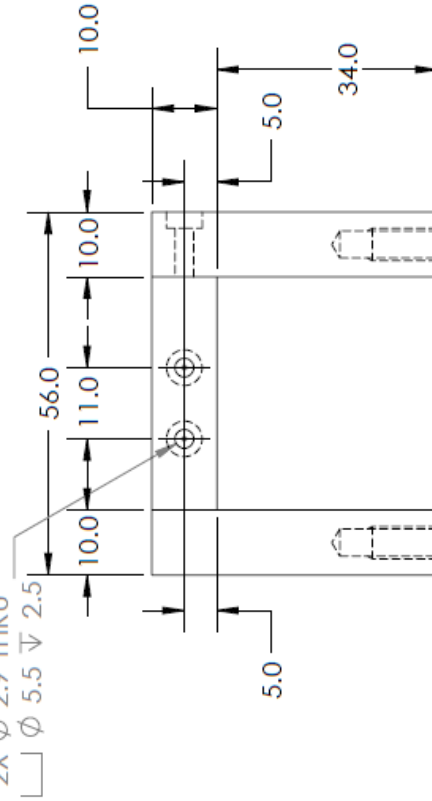

UNLESS OTHERWISE SPECIFIED:		NAME		DATE		WORCESTER POLYTECHNIC INSTITUTE	
DIMENSIONS ARE IN MM		DRAWN	MAF	02-28-2011	TITLE:		
TOLERANCES: ±1.0		CHECKED	JTM	02-28-2011	Piston Support		
INTERPRET GEOMETRIC TOLERANCING PER:		ENG APPR.	LBF	02-28-2011	SIZE	DWG. NO.	REV
MATERIAL		MFG APPR.	SG	02-28-2011	<b>A</b>		
FINISH		COMMENTS:		SCALE: 1:1			
NEXT ASSY		USED ON		APPLICATION			
PROPRIETARY AND CONFIDENTIAL		DO NOT SCALE DRAWING					
THE INFORMATION CONTAINED IN THIS DRAWING IS THE SOLE PROPERTY OF <INSERT COMPANY NAME HERE>. ANY REPRODUCTION IN PART OR AS A WHOLE WITHOUT THE WRITTEN PERMISSION OF <INSERT COMPANY NAME HERE> IS PROHIBITED.							

# Appendix B: Merging Mechanism Drawings

Technical drawing of a Shuttle Stop part. The drawing includes an isometric view, a front view, and a side view. Dimensions are provided for each view.

- Isometric View:** Shows the 3D shape of the part. Dimensions include a total length of 45.0, a width of 5.0, and a radius of R2.5.
- Front View:** Shows the top profile of the part. Dimensions include a total length of 70.0, a width of 15.0, a height of 10.0, and a radius of R2.0.
- Side View:** Shows the side profile of the part. Dimensions include a total length of 25.0, a width of 10.0, and a radius of R2.0.

PROPRIETARY AND CONFIDENTIAL  
 THE INFORMATION CONTAINED IN THIS  
 DRAWING IS THE SOLE PROPERTY OF  
 INERTIC COMPANY NAME HERE. ANY  
 REPRODUCTION IN PART OR AS A WHOLE  
 WITHOUT THE WRITTEN PERMISSION OF  
 INERTIC COMPANY NAME HERE IS  
 PROHIBITED.

UNLESS OTHERWISE SPECIFIED:		NAME	DATE
DIMENSIONS ARE IN INCHES FRACTIONS:			
DECIMALS:			
TOLERANCES:			
FRACTIONS: ± FEND 1			
ANGLES: INCHES ±			
TWO PLACE DECIMAL ±			
THREE PLACE DECIMAL ±			
INTERPRETOMETRIC IDENTIFICATION PER:			
MATERIAL:			
FINISH:			
DO NOT SCALE DRAWING			
APPLICATION			
HEAT ASSY			
USED ON			
TITLE:		SHUTTLE STOP	
SIZE		DWG. NO.	REV
SCALE: 1:1		WEIGHT:	SHEET 1 OF 1

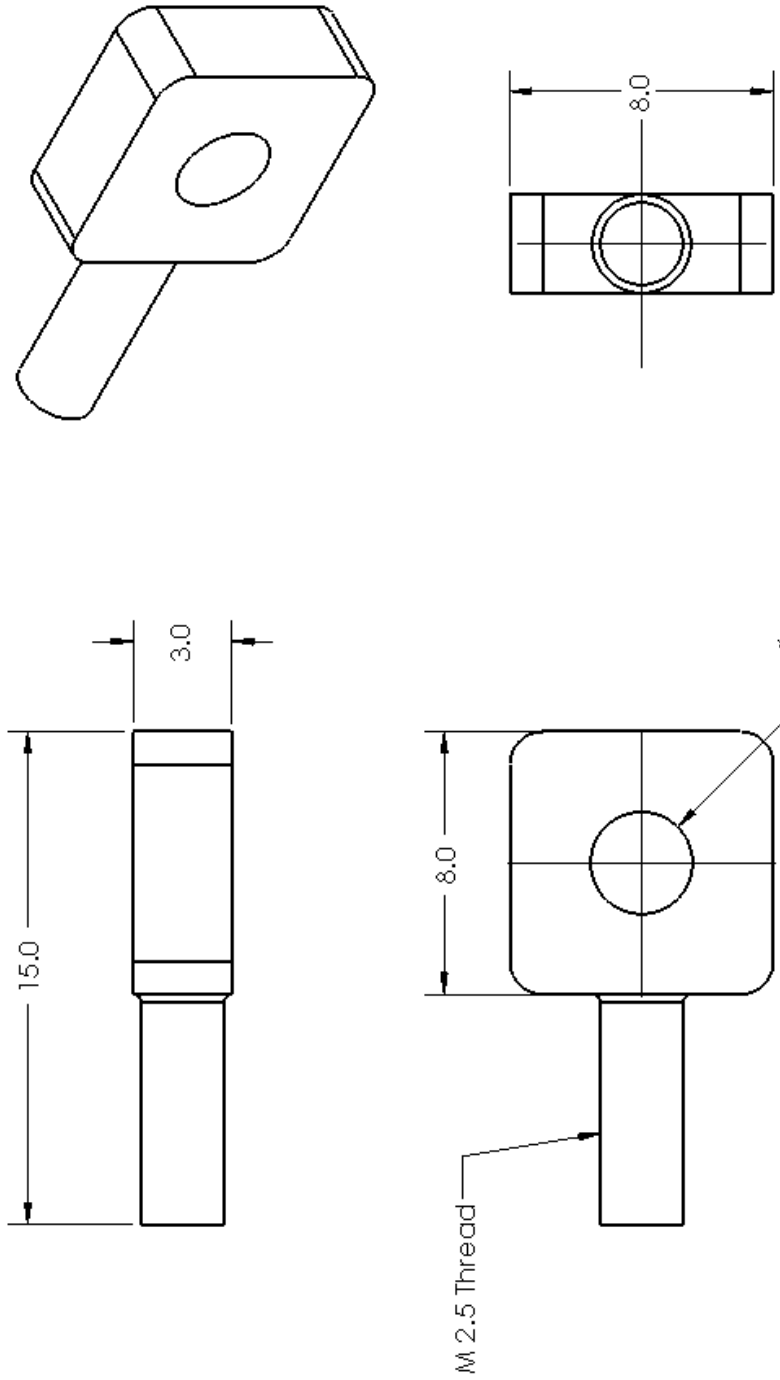

UNLESS OTHERWISE SPECIFIED: DIMENSIONS ARE IN CHS TOLERANCES: FRACTIONS: ±0.005 DECIMALS: ±0.005 ANGLES: ±0.005 HOLE DIA: ±0.005 TWO PLACE DECIMAL ±0.005 THREE PLACE DECIMAL ±0.002		DRAWN	NAME	DATE
INTERPRET GEOMETRIC TOLERANCING PER: ASME Y14.5-2009		CHECKED		
FINISH: UNLESS OTHERWISE SPECIFIED, ALL SURFACES SHALL BE UNFINISHED		ENG APPR.		
MATERIAL: UNLESS OTHERWISE SPECIFIED, ALL MATERIALS SHALL BE AS SUPPLIED		MFG APPR.		
APPLICATION: NEXT ASSY		COMMENTS:		
APPRECIATION: USED ON		SCALE: 5:1	WEIGHT:	SHEET 1 OF 1
TITLE: EYEBOLT		SIZE: A	DWG. NO.:	REV:
DO NOT SCALE DRAWING				

PROPRIETARY AND CONFIDENTIAL  
 THE INFORMATION CONTAINED IN THIS DRAWING IS THE SOLE PROPERTY OF  
 THE COMPANY. ANY REPRODUCTION OR  
 TRANSMISSION IN ANY FORM OR BY ANY  
 MEANS WITHOUT THE WRITTEN PERMISSION OF  
 THE COMPANY IS PROHIBITED.

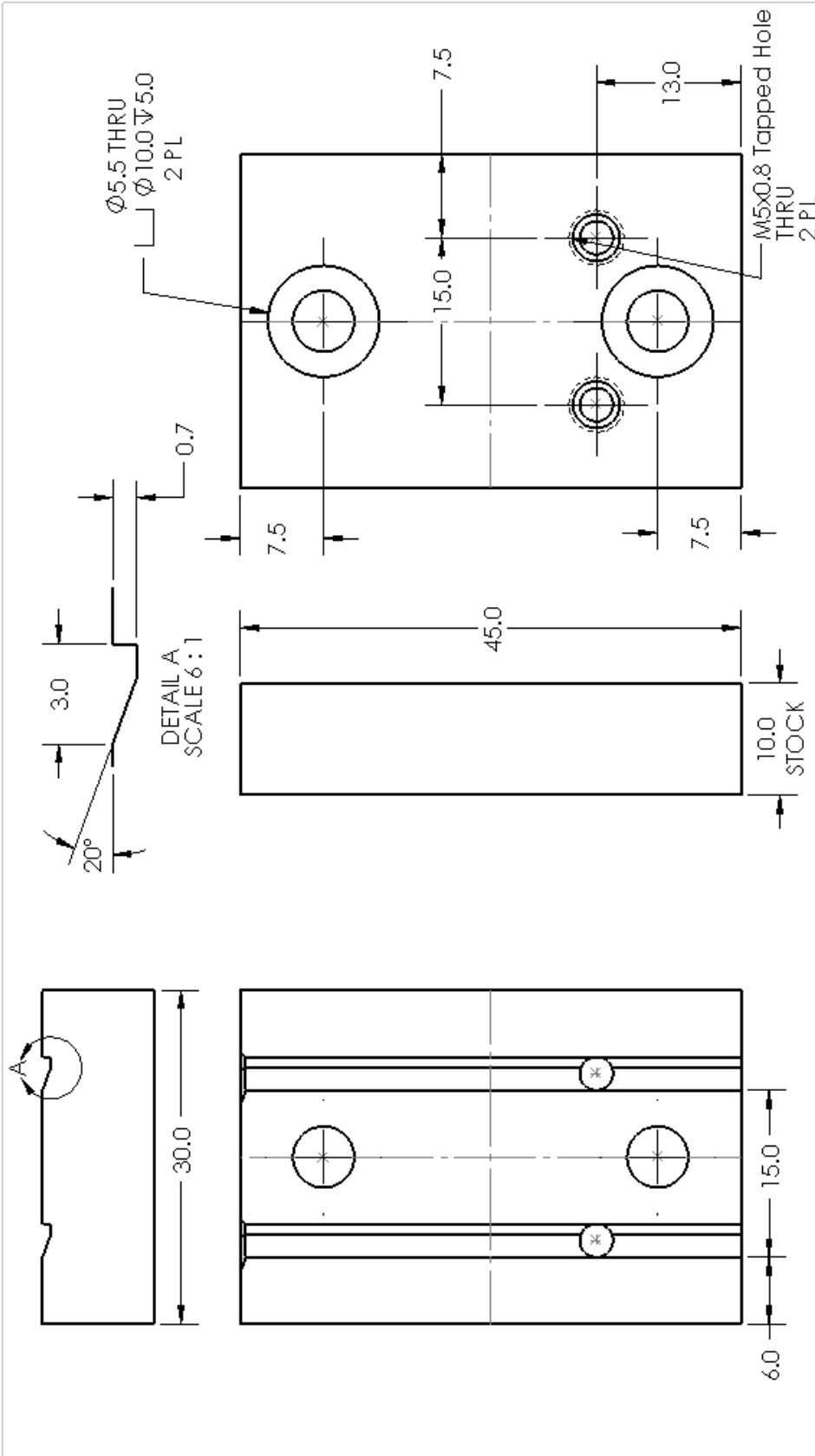

UNLESS OTHERWISE SPECIFIED:		NAME	DATE
DIMENSIONS ARE IN INCHES	DRAWN		
FRACTIONALS	CHECKED		
ANGULAR DIMENSIONS: BEND ±	ENG APPR.		
TWO PLACES DECIMAL ±	MFG APPR.		
THREE PLACES DECIMAL ±	Q. A.		
INTERPRET DIMENS	COMMENTS:		
TOLERANCING PER:			
AS MEET			
INCH			
NEST ASSEMBLY	USED ON		
APPLICATION	DO NOT SCALE DRAWING		

TITLE: SHUTTLE TOP

SIZE DWG. NO. REV

**A**

SCALE: 2:1 WEIGHT: SHEET 1 OF 1

PROPERTY AND CONFIDENTIAL INFORMATION CONTAINED IN THIS DRAWING IS THE SOLE PROPERTY OF INGESTION COMPANY. NO REPRODUCTION OR TRANSMISSION IN ANY FORM OR BY ANY MEANS, WITHOUT THE WRITTEN PERMISSION OF INGESTION COMPANY IS PROHIBITED.

1 2 3 4 5

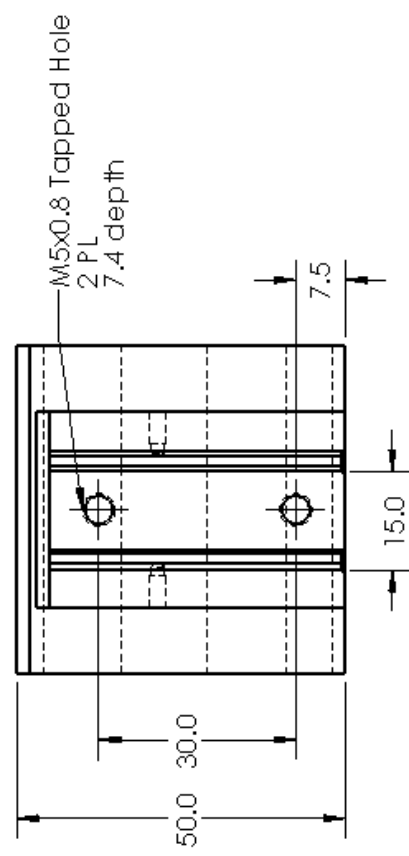
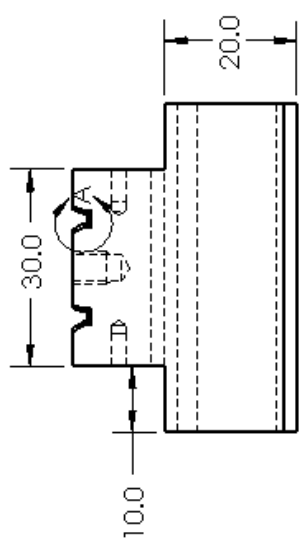
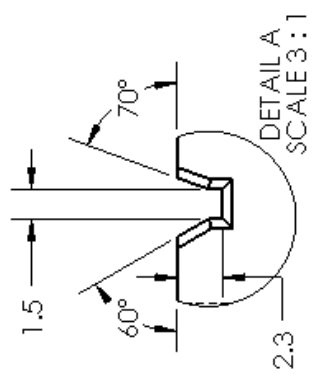
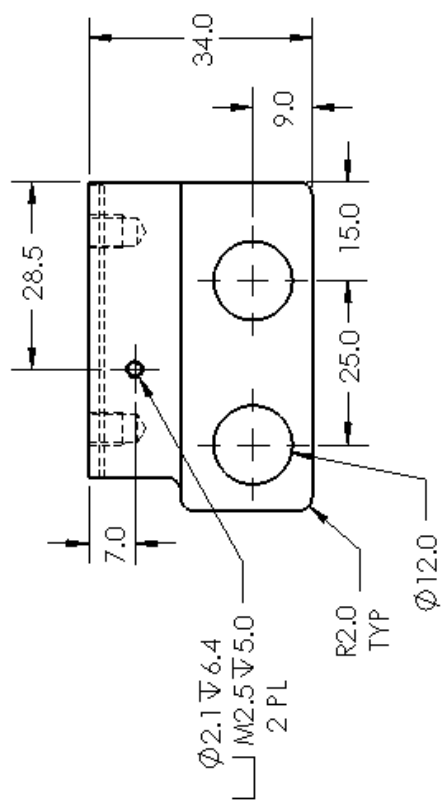

UNLESS OTHERWISE SPECIFIED:		NAME	DATE
DIMENSIONS ARE IN CHS	DRAWN		
TOLERANCES:	CHECKED		
FRACTIONAL ±	ENG APPR.		
ANGULAR: MAX ±	MFG APPR.		
TWO PLACE DECIMAL ±	Q.A.		
THREE PLACE DECIMAL ±	COMMENTS:		
INTERPRET GEOMETRIC TOLERANCING PER:			
MATERIAL:			
FINISH:			
HERT ASSY	LFED ON		
APPLICATION	DO NOT SCALE DRAWING		

TITLE:  
**SHUTTLE BOTTOM**

SIZE DWG. NO. REV  
**A**

SCALE: 1:1 WEIGHT: SHEET 1 OF 1

PROPRIETARY AND CONFIDENTIAL  
THE INFORMATION CONTAINED IN THIS DRAWING IS THE SOLE PROPERTY OF <INSERT COMPANY NAME HERE>. ANY REPRODUCTION IN PART OR AS A WHOLE WITHOUT THE WRITTEN PERMISSION OF <INSERT COMPANY NAME HERE> IS PROHIBITED.

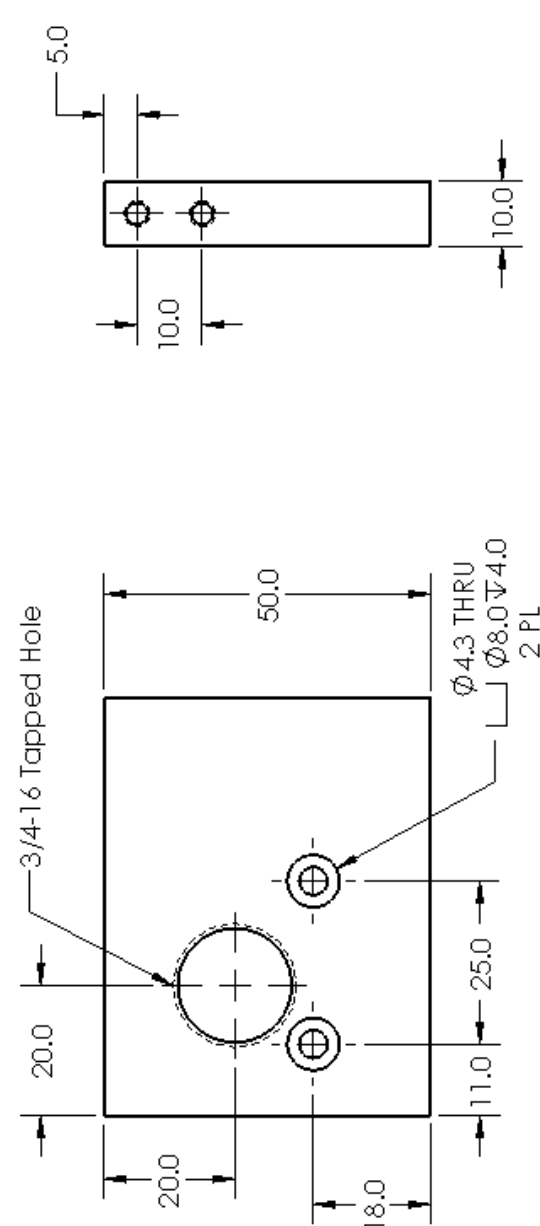
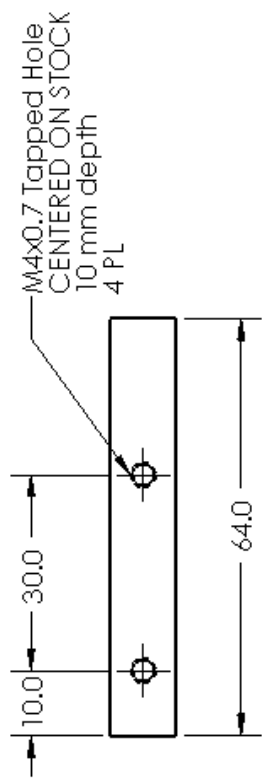

UNLESS OTHERWISE SPECIFIED:		NAME	DATE
DIMENSIONS ARE IN INCHES		DRAWN	
TOLERANCES:		CHECKED	
FRACTIONAL:		ENG APPR.	
DECIMAL:		MFG APPR.	
THREE PLACE DECIMAL:		Q.A.	
THREE PLACE DECIMAL:		COMMENTS:	
INTERPRETATION PER:			
MATERIAL:			
FINISH:			
NET ASSY	USED ON		
APPLICATION		DOWNSCALE DRAWING	
5		3	
4		2	
1		1	

# TEST SOLENOID SUPPORT

SIZE DWG. NO. REV  
**A**

SCALE: 1:1 WEIGHT: SHEET 1 OF 1

PROPRIETARY AND CONFIDENTIAL  
THE INFORMATION CONTAINED IN THIS  
DRAWING IS THE SOLE PROPERTY OF  
INTEGRIC COMPANY. NAME HERE, ANY  
REPRODUCTION IN PART OR AS A WHOLE  
WITHOUT THE WRITTEN PERMISSION OF  
INTEGRIC COMPANY, NAME HERE, IS  
PROHIBITED.



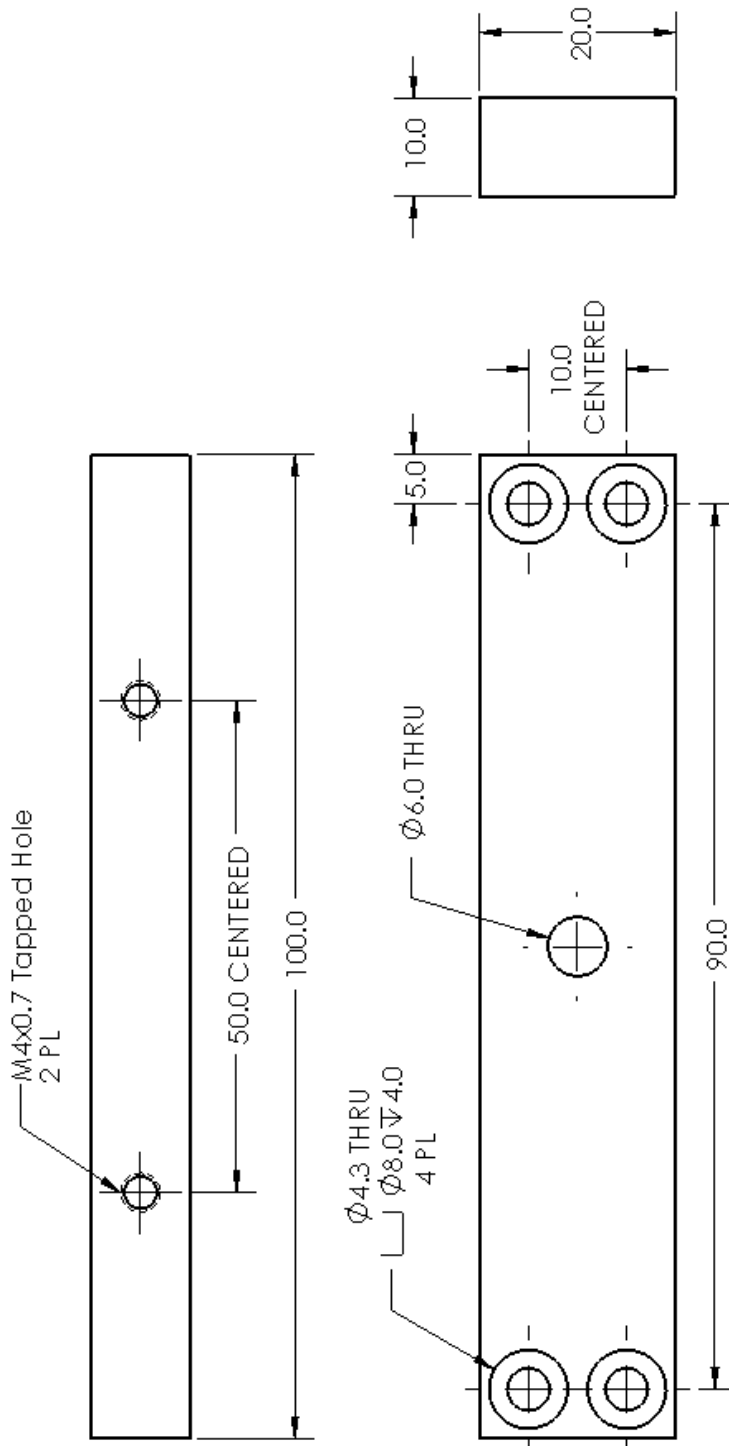

UNLESS OTHERWISE SPECIFIED:		NAME	DATE
DIMENSIONS ARE IN INCHES			
TOLERANCES:		DRAWN	
FRACTIONAL:		CHECKED	
ANGULAR: MACH ± BEND ±		ENG APPR.	
TWO PLACE DECIMAL ±		MFG APPR.	
THREE PLACE DECIMAL ±			
O.A.			
INTERPRET GEOMETRIC TOLERANCING PER:		COMMENTS:	
MATERIAL			
FINISH			
NEXT ASSY		USED ON	
APPLICATION		DONOT SCALE DRAWING	

TITLE: **SHUTTLE BACK SUPPORT**

SIZE DWG. NO. REV  
**A**   
 SCALE: 1:1 WEIGHT: SHEET 1 OF 1

PROPRIETARY AND CONFIDENTIAL  
 THE INFORMATION CONTAINED IN THIS DRAWING IS THE SOLE PROPERTY OF <INSERT COMPANY NAME HERE>. ANY REPRODUCTION IN PART OR AS A WHOLE WITHOUT THE WRITTEN PERMISSION OF <INSERT COMPANY NAME HERE> IS PROHIBITED.

ITEM NO.	PART NUMBER	QTY.
1	Solenoid Support	2
2	Shuttle Guide Rails	2
3	Shuttle Back Support	1
4	Nest	1
5	Track Support	1
6	Track Bottom 140	1
7	Track Top	2
8	Shuttle Stop	1
9	Festo_Fitting	2
10	Shuttle	1
11	Solenoid	2

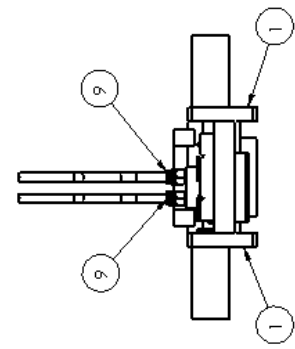
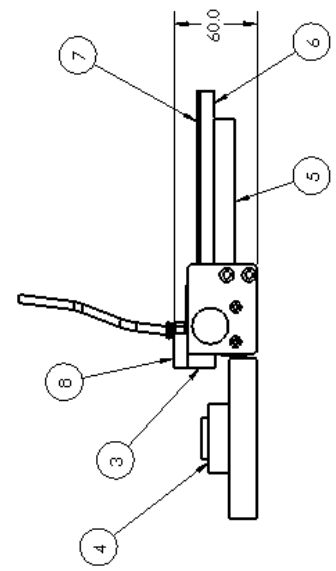
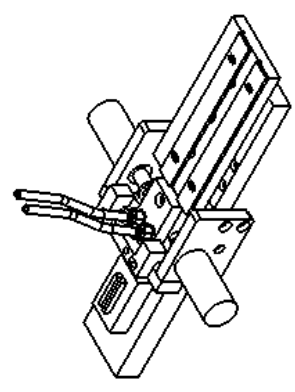
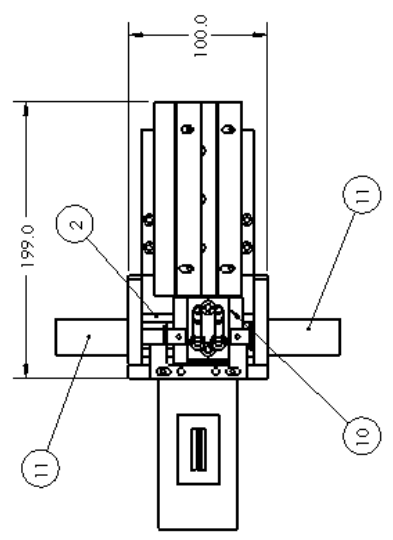

UNLESS OTHERWISE SPECIFIED:	UNIT	DATE
DIMENSIONS	MILLIMETERS	
FINISHES	AS SPECIFIED	
APPROVALS	DATE	
DESIGNED BY		
CHECKED BY		
PROGRAMMERS		
WELDERS		
DRYERS		
CONTRACTORS		

TITLE: **SHUTTLE ASSEMBLY**

SIZE: DWG. NO. **B** REV. **B**

SCALE: 1:1 WEIGHT: SHEET 1 OF 1

PROPERTY AND CONSTRUCTION OF THIS DRAWING IS THE PROPERTY OF THE COMPANY AND IS NOT TO BE REPRODUCED OR TRANSMITTED IN ANY FORM OR BY ANY MEANS, ELECTRONIC OR MECHANICAL, WITHOUT PERMISSION IN WRITING FROM THE COMPANY.



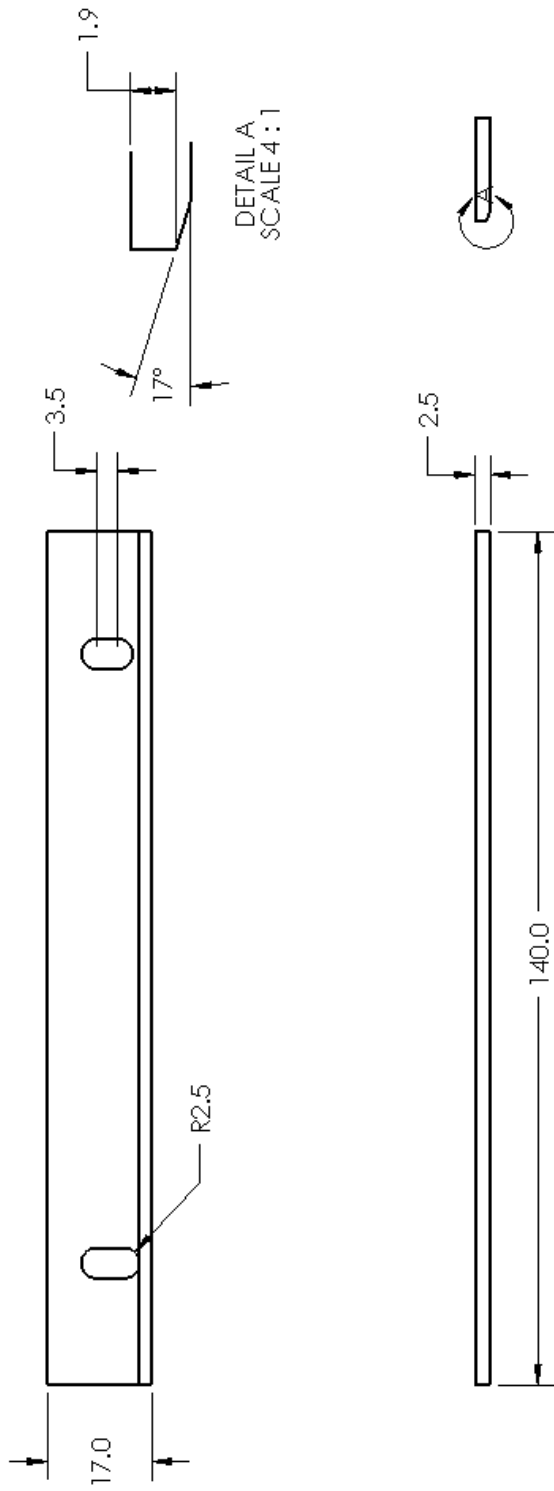

DETAIL A  
SCALE 4:1

# TRACKTOP

UNLESS OTHERWISE SPECIFIED:		NAME	DATE
DIMENSIONS ARE IN INCHES		DRAWN	
TOLERANCES:		CHECKED	
FRACTIONALLY		ENG APPR.	
ANGULAR: MACH ±		MFG APPR.	
BEND ±		Q.A.	
TWO PLACE DECIMAL ±		COMMENT:	
THREE PLACE DECIMAL ±			
INTERFEROMETRIC			
MATERIAL			
FINISH			
NEXT ASSY		USED ON	
APPLICATION			

PROPRIETARY AND CONFIDENTIAL  
THE INFORMATION CONTAINED IN THIS DRAWING IS THE SOLE PROPERTY OF  
INSERT COMPANY NAME HERE. ANY  
REPRODUCTION IN ANY MANNER WITHOUT  
THE WRITTEN PERMISSION OF  
INSERT COMPANY NAME HERE IS  
PROHIBITED.

SIZE DWG. NO. REV

**A**

SCALE: 1:5 WEIGHT: SHEET 1 OF 1



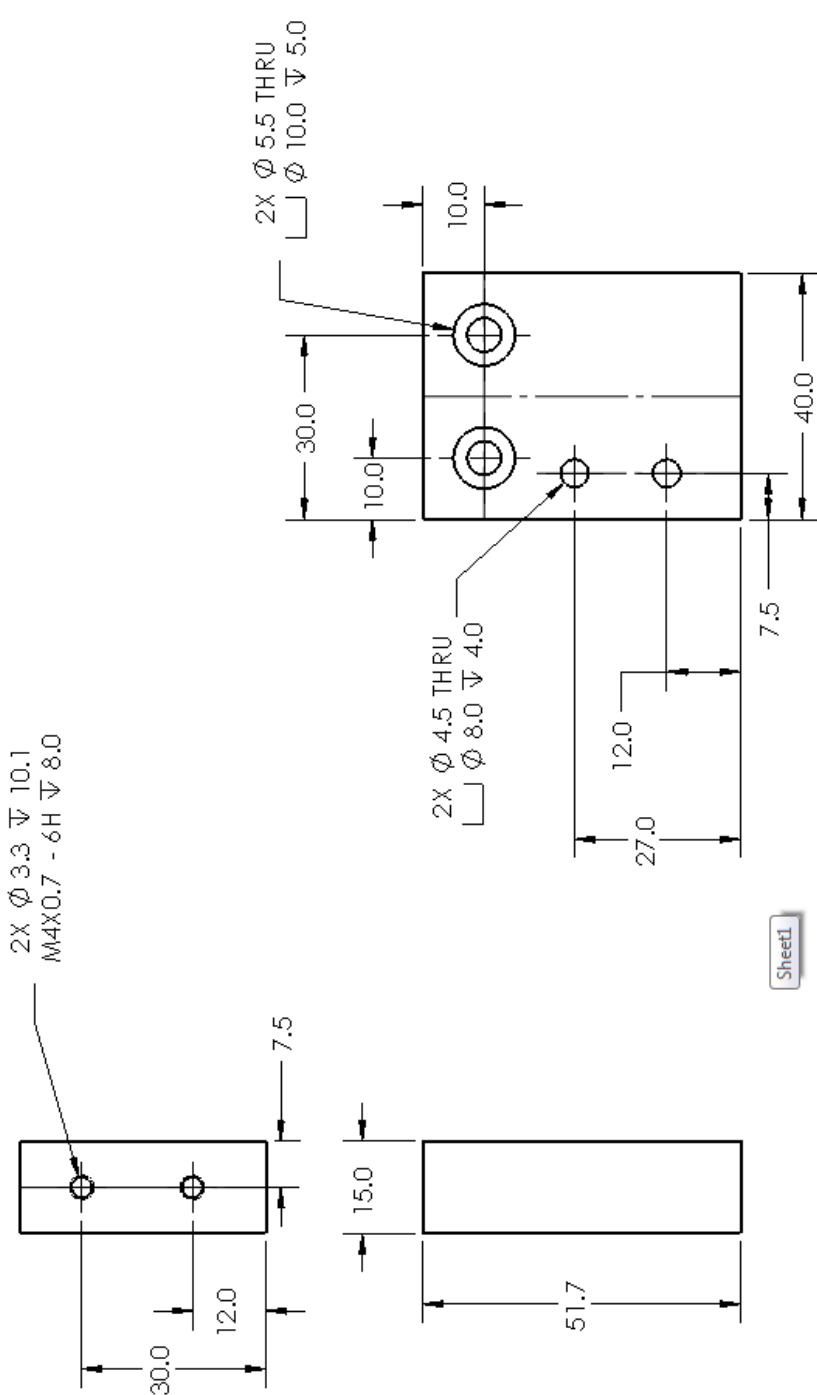

Sheet 1

UNLESS OTHERWISE SPECIFIED:		DRAWN		NAME		DATE	
DIMENSIONS ARE IN INCHES		CHECKED					
TOLERANCES:		ENG APPR.					
FRACTIONS:		MFG APPR.					
ANGLES: MA CHZ		Q.A.					
BEND: 1		COMMENTS:					
TWO PLACE DECIMAL 1							
THREE PLACE DECIMAL 1							
INTERPRET GEOMETRIC TOLERANCING PER:							
MATERIAL:							
FINISH:							
NEXT ASSY USED ON:							
APPLICATION:							
APPLICATION		DO NOT SCALE DRAWING		SCALE: 1:1		WEIGHT:	
5		3		2		1	
<p>PROPRIETARY AND CONFIDENTIAL</p> <p>THE INFORMATION CONTAINED IN THIS DRAWING IS THE SOLE PROPERTY OF &lt;FIRM&gt;. NO PART OF THIS DRAWING IS TO BE REPRODUCED OR TRANSMITTED IN ANY FORM OR BY ANY MEANS, WITHOUT THE WRITTEN PERMISSION OF &lt;FIRM&gt;. &lt;FIRM&gt; COMPANY NAME HEREIN IS PROHIBITED.</p>		<p>TITLE:</p> <h1>FRAME FRONT TRACK</h1>		<p>SIZE DWG. NO.</p> <h1>A</h1>		<p>REV</p>	
						SHEET 1 OF 1	

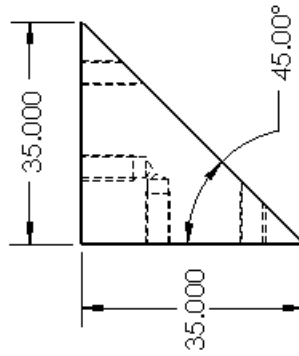
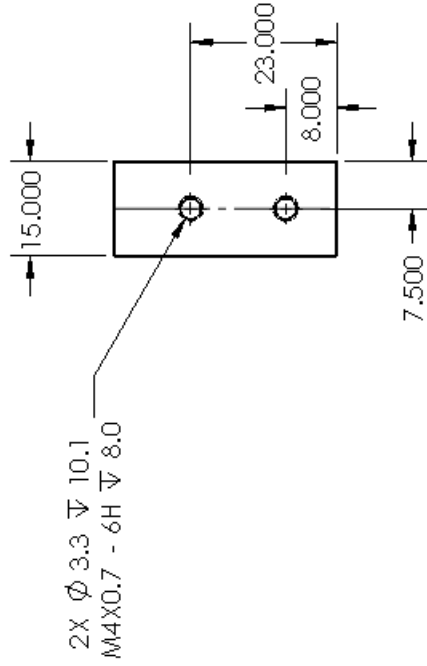
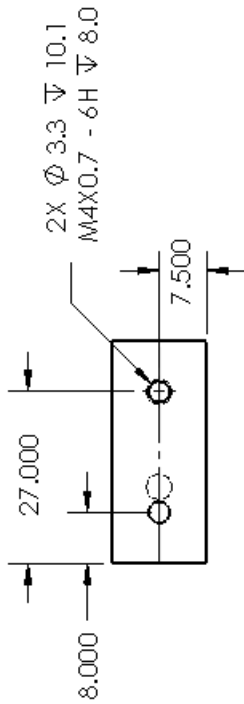

Sheet 1

UNLESS OTHERWISE SPECIFIED:		DRAWN		NAME		DATE	
DIMENSIONS ARE IN INCHES		CHECKED					
TOLERANCES:		ENG APPR.					
FRACTIONALS		MFG APPR.					
ANGULAR: MAX CH ± BEND ±		Q.A.					
TWO PLACE DECIMAL ±		COMMENTS:					
THREE PLACE DECIMAL ±		INTERPRET GEOMETRIC					
		TOLERANCING PER:					
		MATERIAL				TITLE: FRONT SUPPORT GUSSET	
		FINISH				SIZE DWG. NO. REV	
		LUBED ON				A	
APPLICATION		DONOT SCALE DRAWING		SCALE: 1:1		WEIGHT: SHEET 1 OF 1	
5		4		3		2	
1		1		1		1	

PROPRIETARY AND CONFIDENTIAL  
 THE INFORMATION CONTAINED IN THIS  
 DRAWING IS THE SOLE PROPERTY OF  
 <INSERT COMPANY NAME HERE>. ANY  
 REPRODUCTION IN PART OR AS A WHOLE  
 WITHOUT THE WRITTEN PERMISSION OF  
 <INSERT COMPANY NAME HERE> IS  
 PROHIBITED.





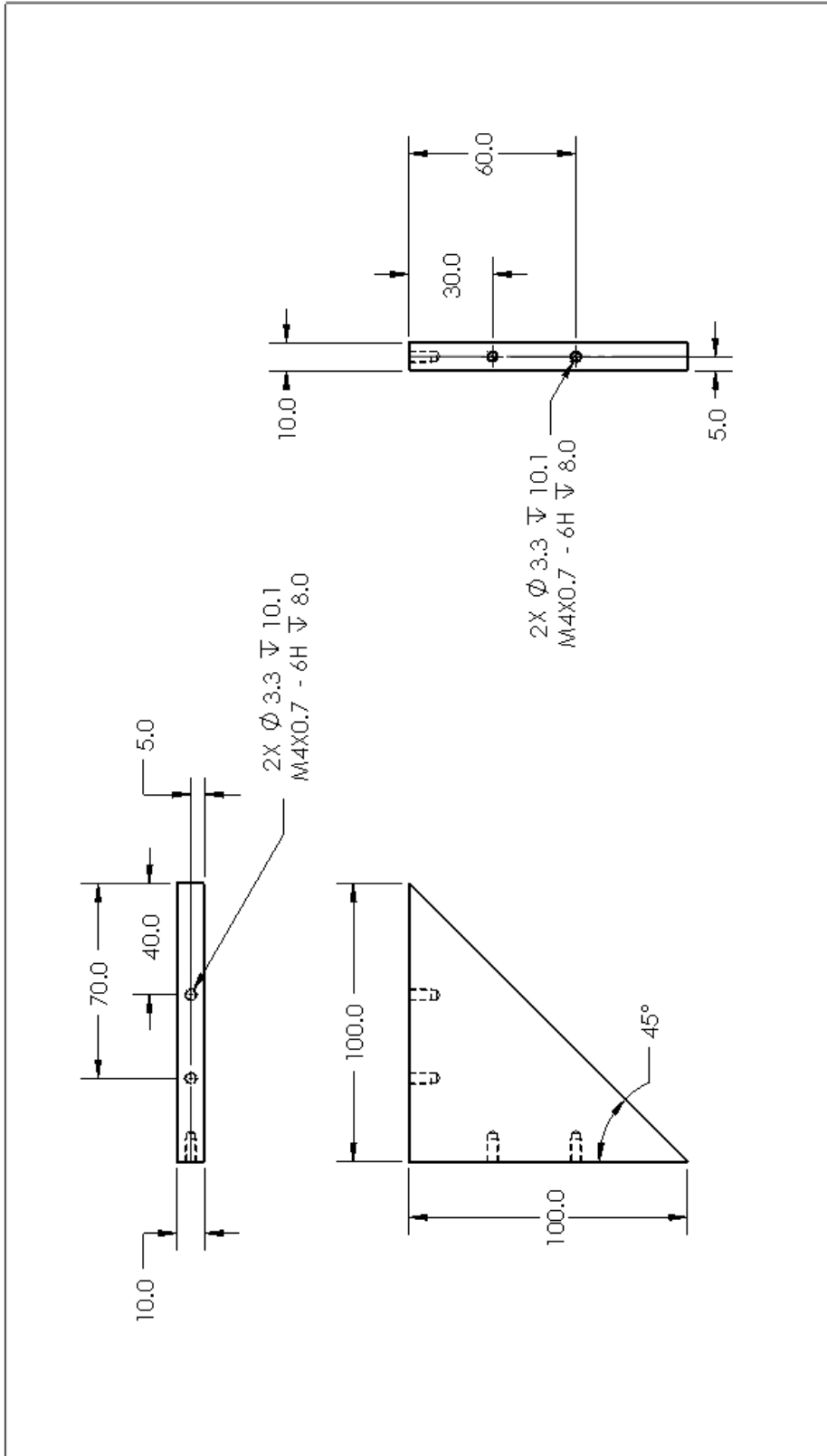

UNLESS OTHERWISE SPECIFIED:		NAME	DATE
DIMENSIONS ARE IN INCHES			
TOLERANCES:		DRAWN	
FRACTIONALS		CHECKED	
ANGLER: MACH 1 BEND 1		ENGR APPR.	
TWO PLACE DECIMAL 2		MFG APPR.	
THREE PLACE DECIMAL 3		Q.A.	
INTERPRET GEOMETRIC TOLERANCING PER:		COMMENTS:	
MATERIAL			
FINISH			
HEAT TREAT	USED ON	SIZE DWG. NO.	
APPLICATION		A	
		SCALE: 1:2	
		WEIGHT:	
		SHEET 1 OF 1	

PROPRIETARY AND CONFIDENTIAL  
 THE INFORMATION CONTAINED IN THIS  
 DRAWING IS THE SOLE PROPERTY OF  
 <INSERT COMPANY NAME HERE>. ANY  
 REPRODUCTION IN PART OR AS A WHOLE  
 WITHOUT THE WRITTEN PERMISSION OF  
 <INSERT COMPANY NAME HERE> IS  
 PROHIBITED.

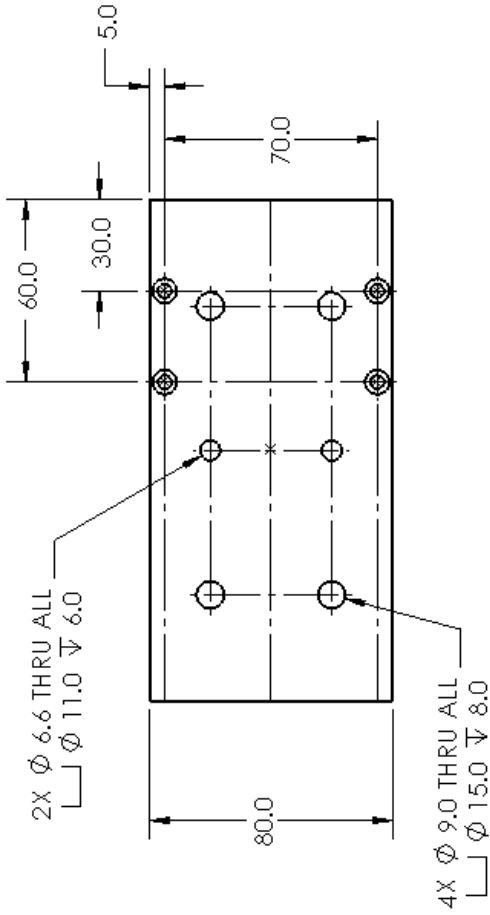

PROPRIETARY AND CONFIDENTIAL THE INFORMATION CONTAINED IN THIS DRAWING IS THE SOLE PROPERTY OF <INSERT COMPANY NAME HERE>. ANY REPRODUCTION IN PART OR AS A WHOLE WITHOUT THE WRITTEN PERMISSION OF <INSERT COMPANY NAME HERE> IS PROHIBITED.		UNLESS OTHERWISE SPECIFIED: DIMENSIONS ARE IN INCHES FRACTIONS:     <INSERT> ANGULAR:     MA CH I   BEND I TWO PLACE DECIMAL I THREE PLACE DECIMAL I INTERPRET GEOMETRIC TOLERANCING PER:		D DRAWN CHECKED ENG APPR. MFG APPR. Q.A.	NAME DATE	TITLE: <b>HORIZONTAL          BASE PLATE</b>
		MATERIAL FINISH USED ON NEXT ASSY	COMMENTS: DO NOT SCALE DRAWING	SIZE <b>A</b>	DWG. NO. REV	SCALE: 1:2 WEIGHT:
APPLICATION 4		3		2		1

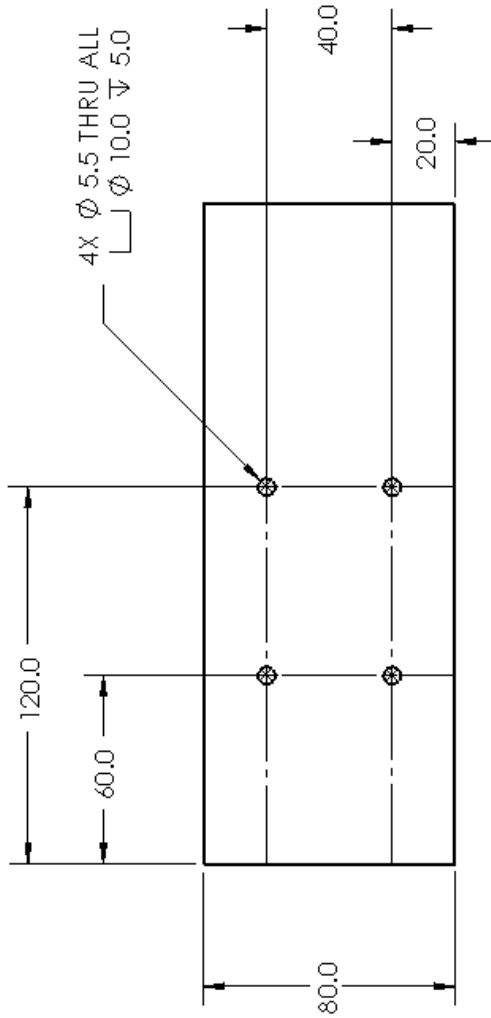

PROPRIETARY AND CONFIDENTIAL THE INFORMATION CONTAINED IN THIS DRAWING IS THE SOLE PROPERTY OF <INSERT COMPANY NAME HERE>. ANY REPRODUCTION IN PART OR AS A WHOLE WITHOUT THE WRITTEN PERMISSION OF <INSERT COMPANY NAME HERE> IS PROHIBITED.		UNLESS OTHERWISE SPECIFIED: DIMENSIONS ARE IN INCHES FRACTIONAL:		DRAWN	NAME	DATE
		ANGULAR: 90° CH1 BEND 2 TWO PLACE DECIMAL 1 THREE PLACE DECIMAL 1		CHECKED		
INTERPRET GEOMETRIC TOLERANCING PER:		MATERIAL:		ENG. APPR.		
FINISH:		USED ON:		MFG. APPR.		
NEXT ASSY:		APPLICATION:		Φ.A.		
DO NOT SCALE DRAWING		COMMENTS:		TITLE:		
SCALE: 1:2		WEIGHT:		RAIL SUPPORT		
SHEET 1 OF 1		DWG. NO.		SIZE		
1		2		A		
3		4		REV		
5		1		SCALE: 1:2		

M4 x 0.7  $\Psi$  10.1  $\phi$  6.0

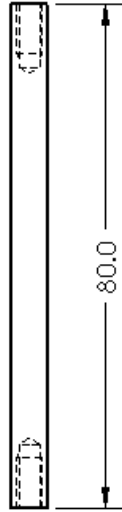

PROPRIETARY AND CONFIDENTIAL  
 THE INFORMATION CONTAINED IN THIS  
 DRAWING IS THE SOLE PROPERTY OF  
 <INSERT COMPANY NAME HERE>. ANY  
 REPRODUCTION IN PART OR AS A WHOLE  
 WITHOUT THE WRITTEN PERMISSION OF  
 <INSERT COMPANY NAME HERE> IS  
 PROHIBITED.

UNLESS OTHERWISE SPECIFIED: DIMENSIONS ARE IN INCHES TO LEADING FRACTIONS: ANGULAR: AMS CH 1 BEND 2 TWO PLACE DECIMAL 1 THREE PLACE DECIMAL 1 INTERPRET GEOMETRIC TOLERANCING PER: MATERIAL FINISH		DRAWN	NAME	DATE
NEXT ASSY		CHECKED		
LEED ON		ENG APPR.		
APPLICATION		MFG APPR.		
APPICATION		$\phi$ A.		
APPICATION		COMMENTS:		
APPICATION		TITLE: <b>SHUTTLE GUIDE SHAFT</b>		
APPICATION		SIZE	DWG. NO.	REV
APPICATION			<b>A</b>	
APPICATION		SCALE: 1:1	WEIGHT:	SHEET 1 OF 1

5 4 3 2 1

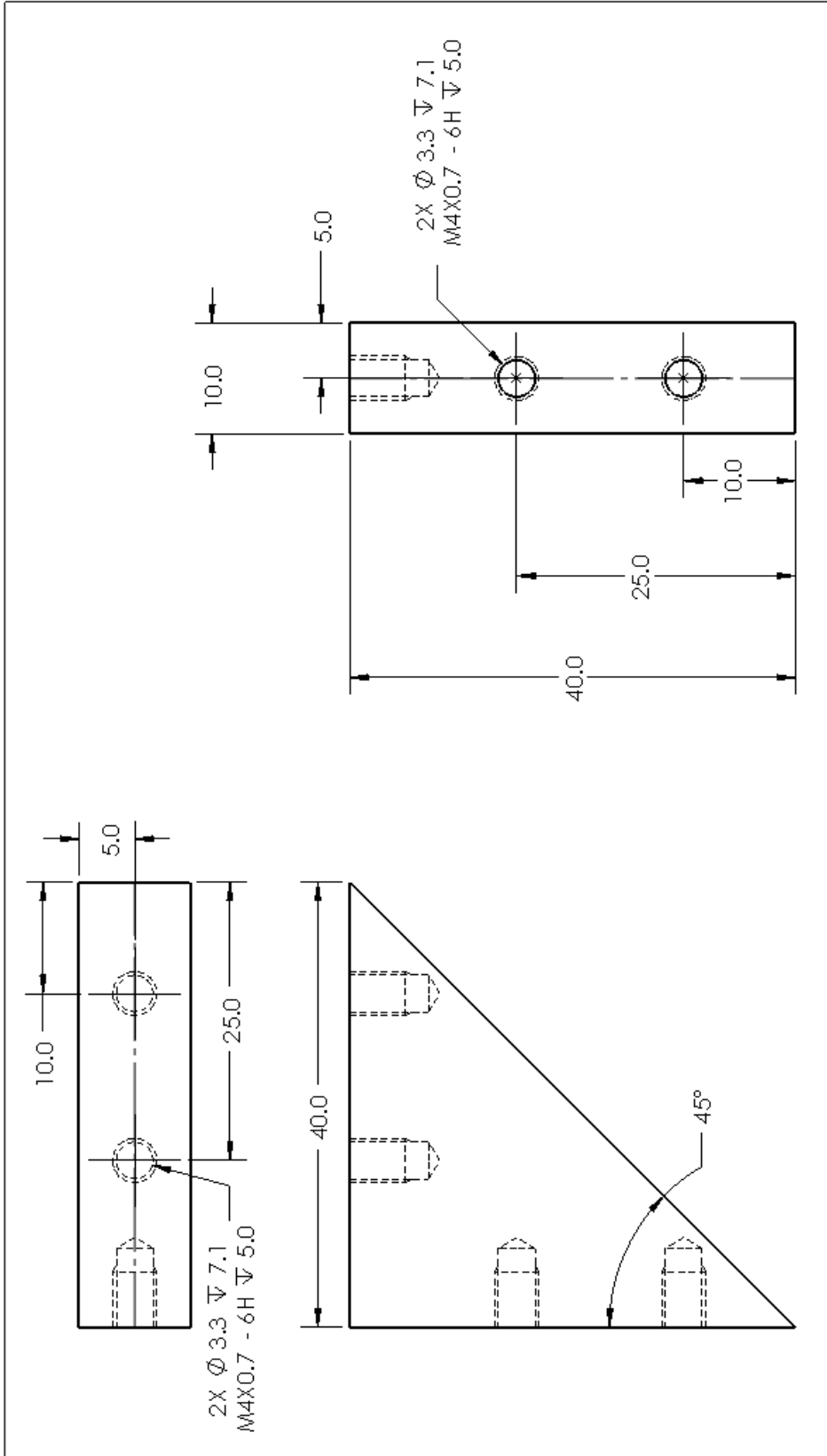

UNLESS OTHERWISE SPECIFIED:		DRAWN	NAME	DATE
DIMENSIONS ARE IN INCHES		CHECKED		
FRACTIONS:		ENG APPR.		
ANGULAR: MAX CHZ BEND ±		MFG APPR.		
TWO PLACE DECIMAL ±		Q.A.		
THREE PLACE DECIMAL ±		COMMENTS:		
INTERPRET GEOMETRIC TOLERANCING PER:				
MATERIAL:				
FINISH:				
NEXT ASSY	USED ON			
APPLICATION				

PROPRIETARY AND CONFIDENTIAL  
 THE INFORMATION CONTAINED IN THIS DRAWING IS THE SOLE PROPERTY OF GIBSON INDUSTRIES, INC. ANY REPRODUCTION OR TRANSMISSION OF THIS DRAWING WITHOUT THE WRITTEN PERMISSION OF GIBSON INDUSTRIES, INC. IS PROHIBITED.

TITLE: **SMALL TRACK GUSSET**  
 SIZE: **A** DWG. NO.: \_\_\_\_\_ REV: \_\_\_\_\_  
 SCALE: 2:1 WEIGHT: \_\_\_\_\_ SHEET 1 OF 1

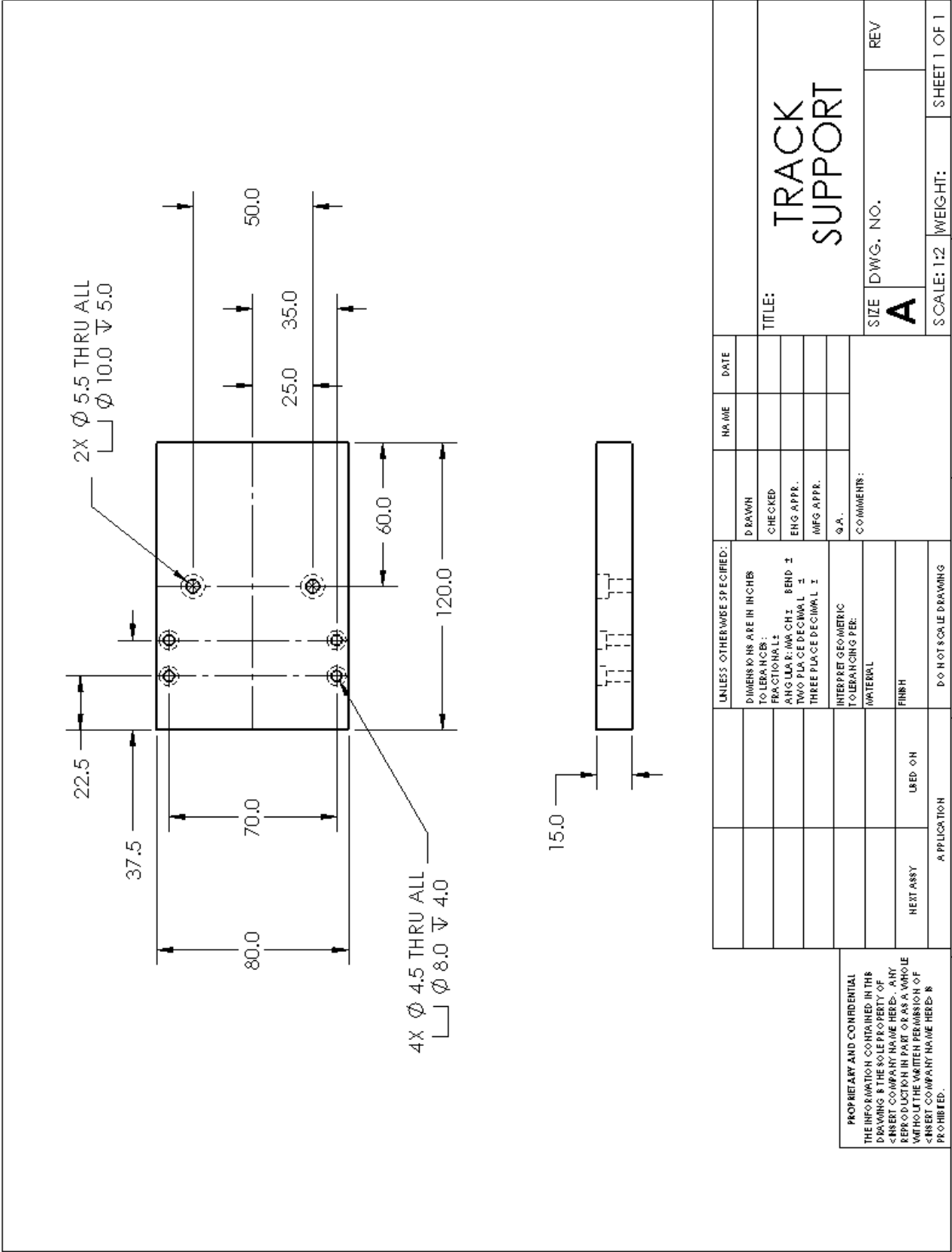

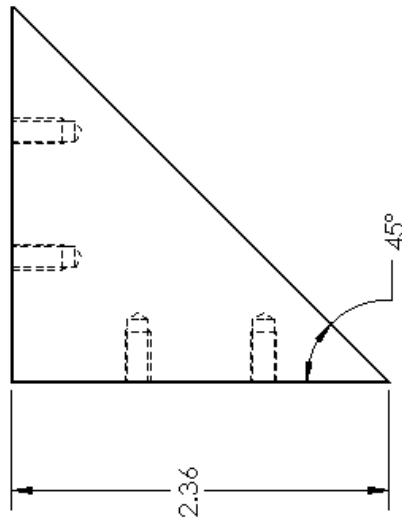
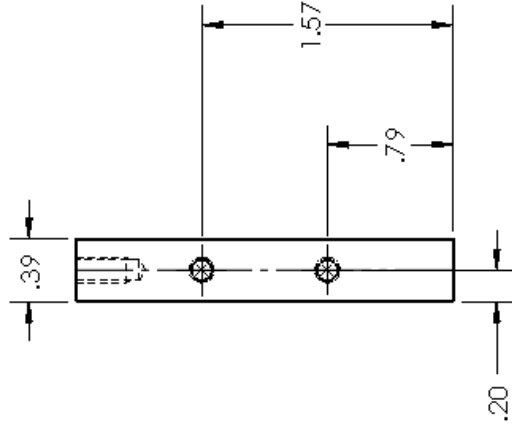
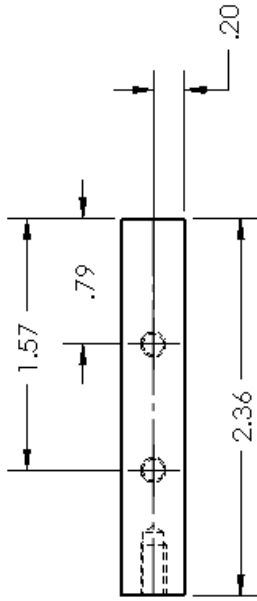

<p><b>PROPRIETARY AND CONFIDENTIAL</b>          THE INFORMATION CONTAINED IN THIS DRAWING IS THE SOLE PROPERTY OF &lt;INHERIT COMPANY NAME HERE&gt;. ANY REPRODUCTION IN PART OR AS A WHOLE WITHOUT THE WRITTEN PERMISSION OF &lt;INHERIT COMPANY NAME HERE&gt; IS PROHIBITED.</p>		APPLICATION		DO NOT SCALE DRAWING		COMMENTS:		SIZE <b>A</b> DWG. NO. REV SCALE: 1:1 WEIGHT: SHEET 1 OF 1	
		NEXT ASSY	USED ON						
UNLESS OTHERWISE SPECIFIED:		DRAWN		NAME		DATE		TITLE: <b>VERTICAL GUSSET</b>	
DIMENSIONS ARE IN INCHES		CHECKED							
TOLERANCES:		ENGR APPR.							
FRACTIONAL:		MFG APPR.							
ANGULAR: MACH ± BEND ±		Q. A.							
TWO PLACE DECIMAL ±									
THREE PLACE DECIMAL ±									
INTERPRET GEOMETRIC TOLERANCING PER:									
MATERIAL									
FINISH									

## Appendix D: Product Testing Results

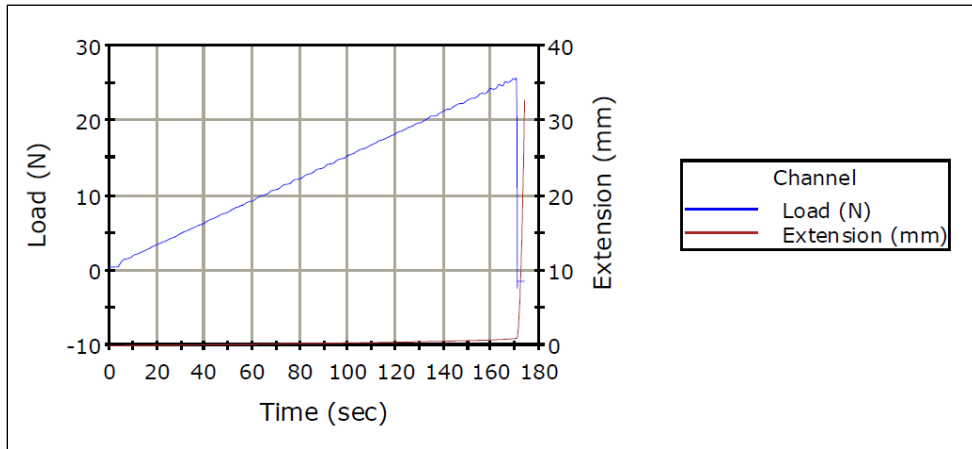

Figure 54: Sample 2-Load versus Time

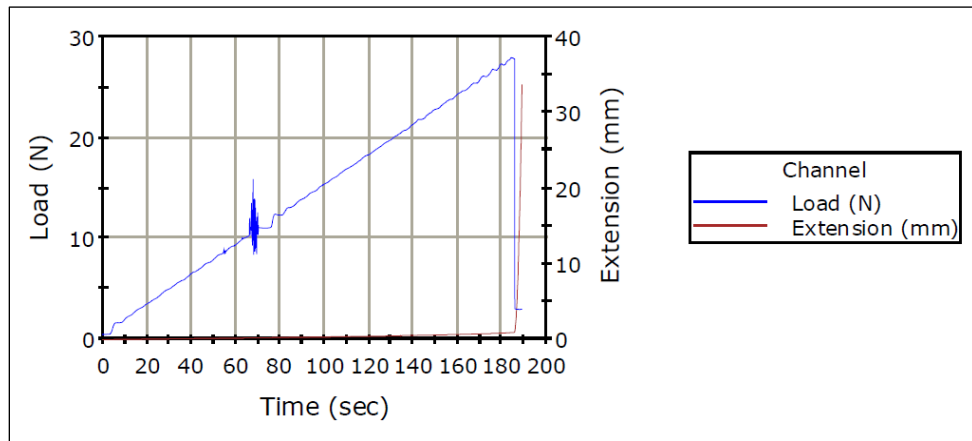

Figure 55: Sample 3-Load versus Time

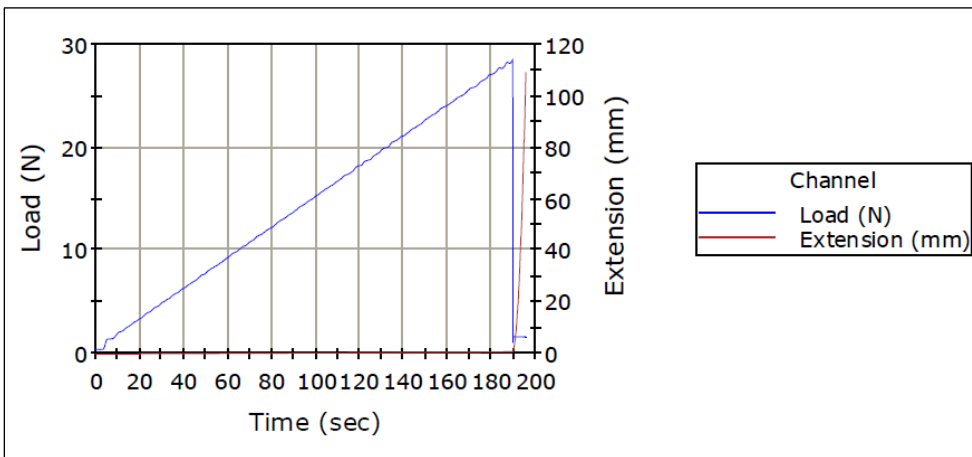

Figure 56: Sample 4-Load versus Time



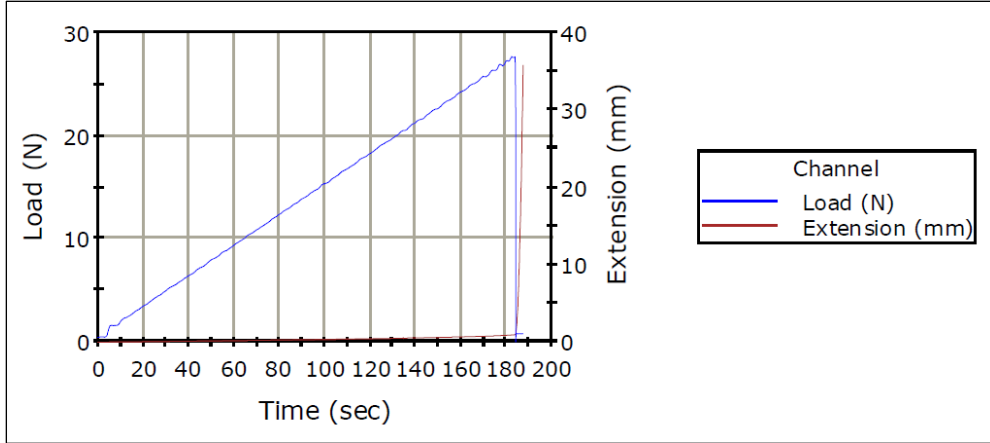

Figure 57: Sample 5-Load versus Time

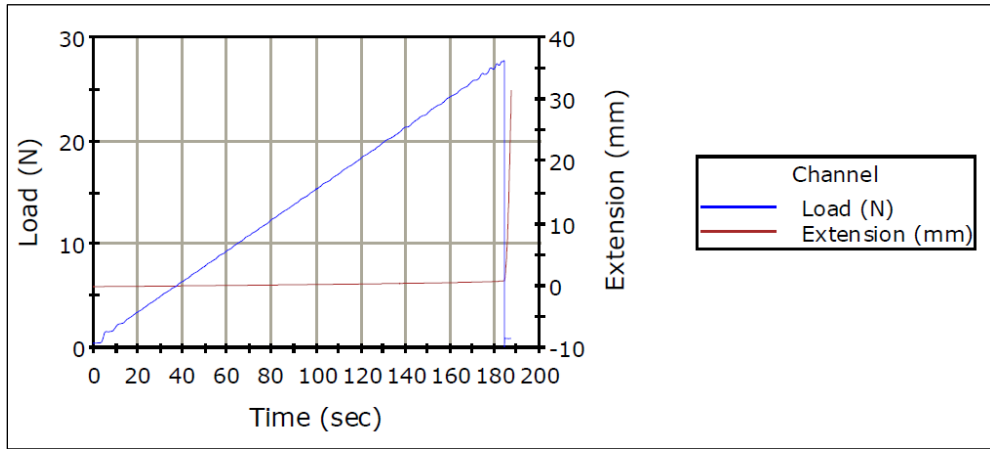

Figure 58: Sample 6-Load versus Time

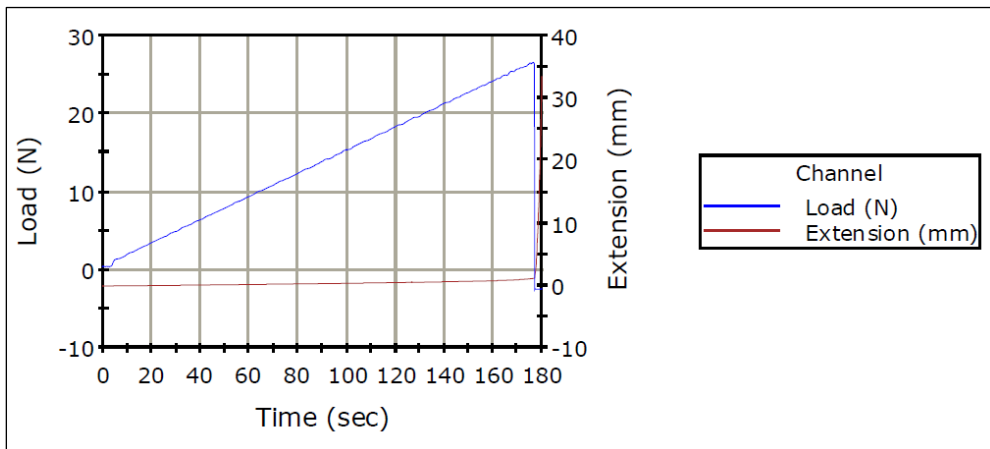

Figure 59: Sample 7-Load versus Time

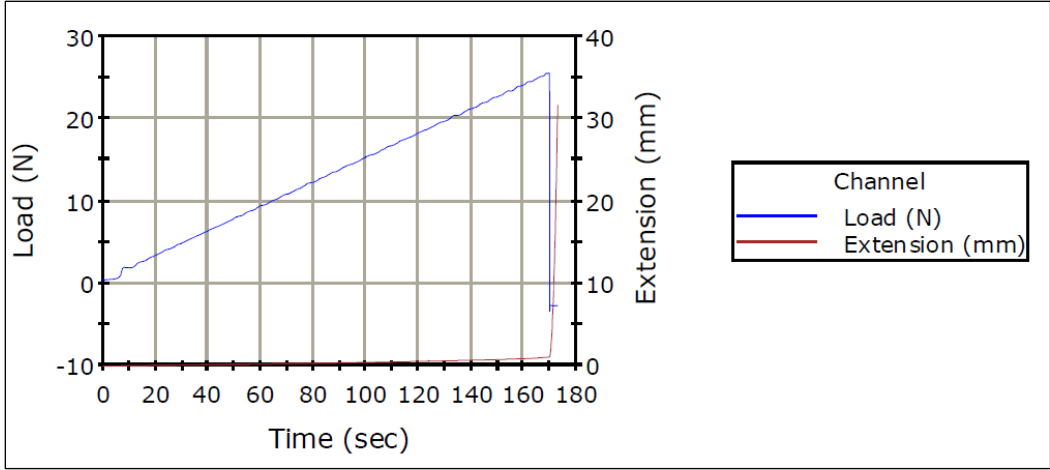

Figure 60: Sample 8-Load versus Time

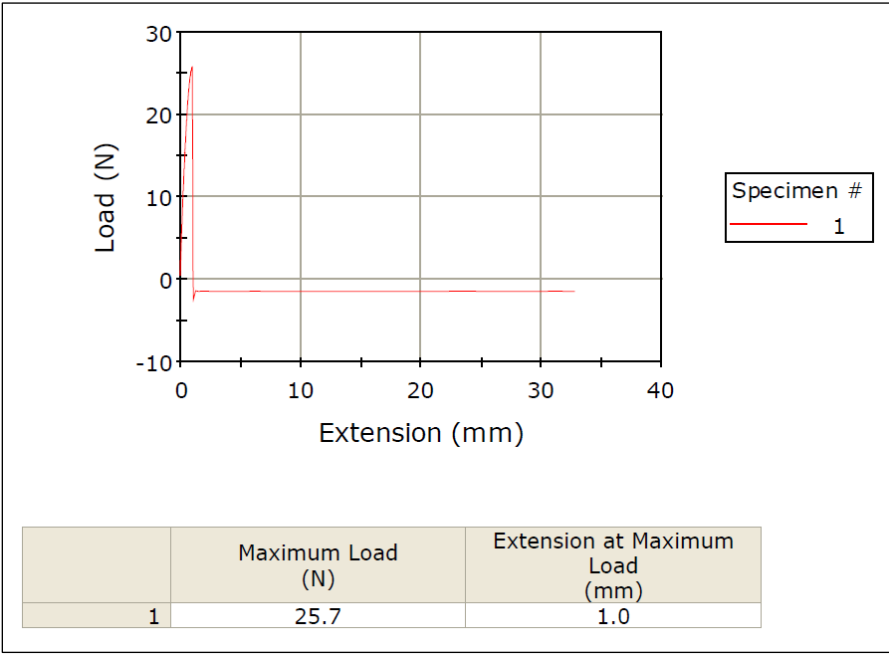

Figure 61: Sample 2-Load versus Extension

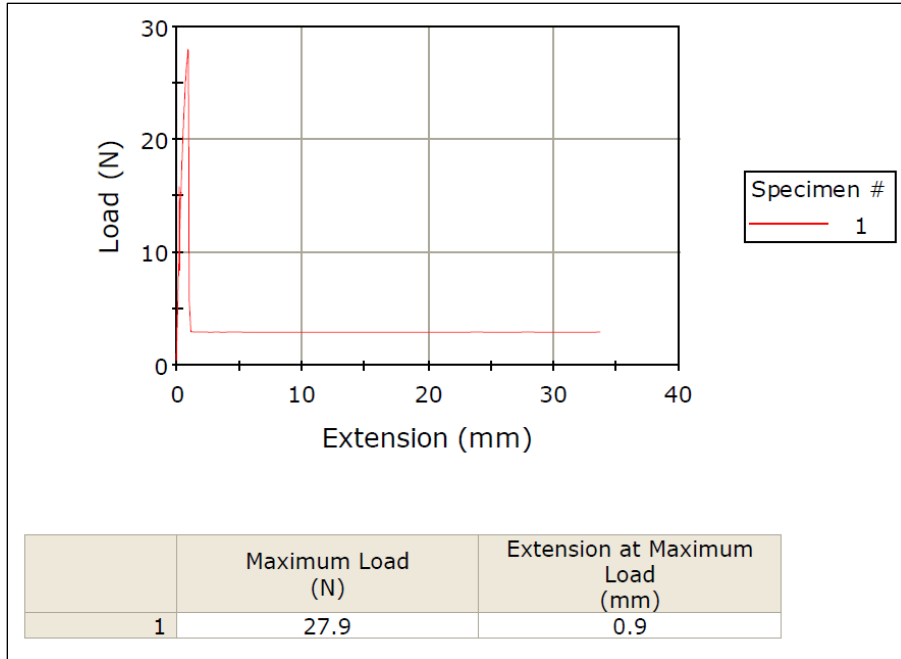

Figure 62: Sample 3-Load versus Extension

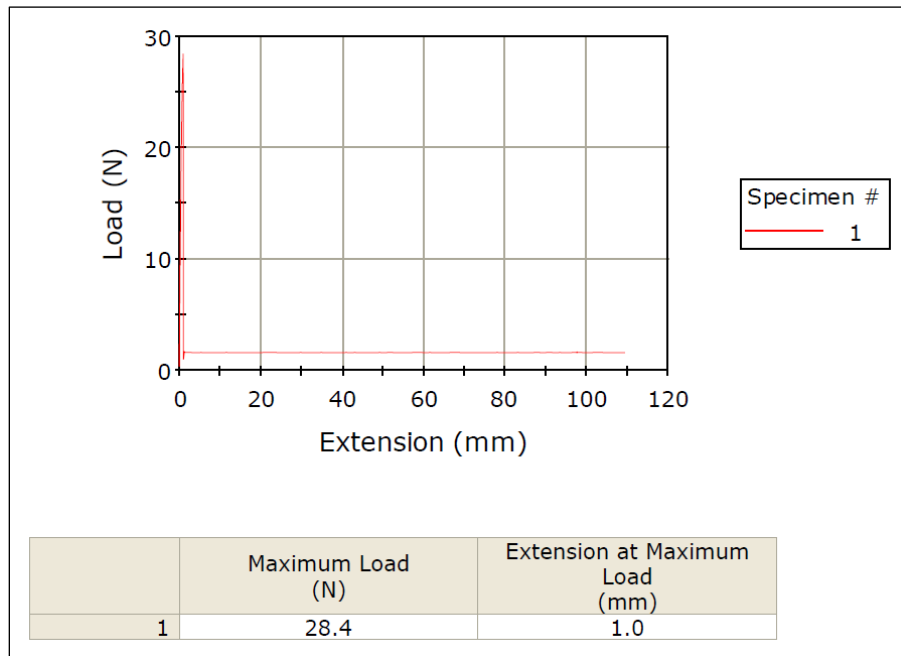

Figure 63: Sample 4-Load versus Extension

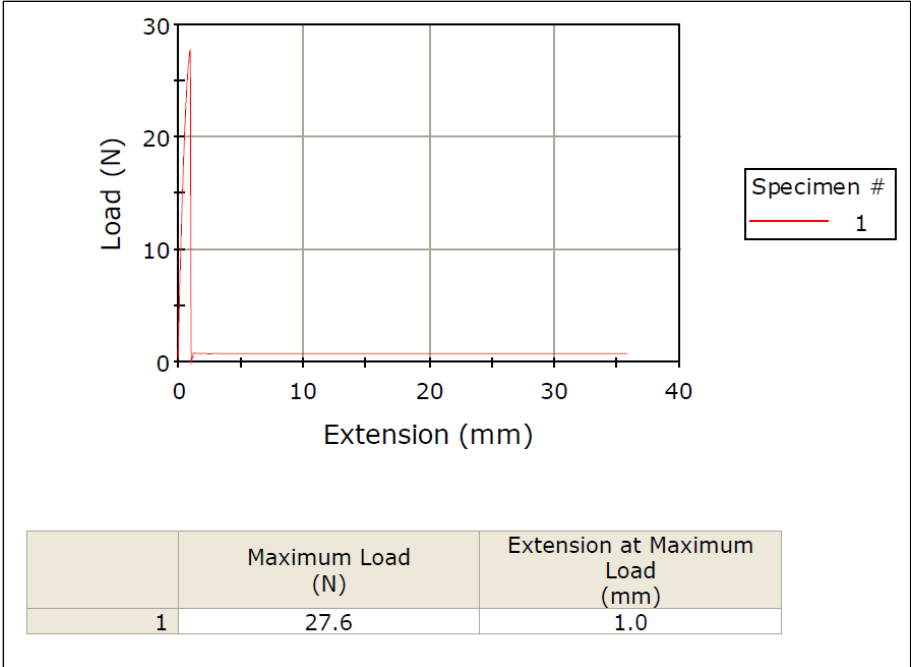

Figure 64: Sample 5-Load versus Extension

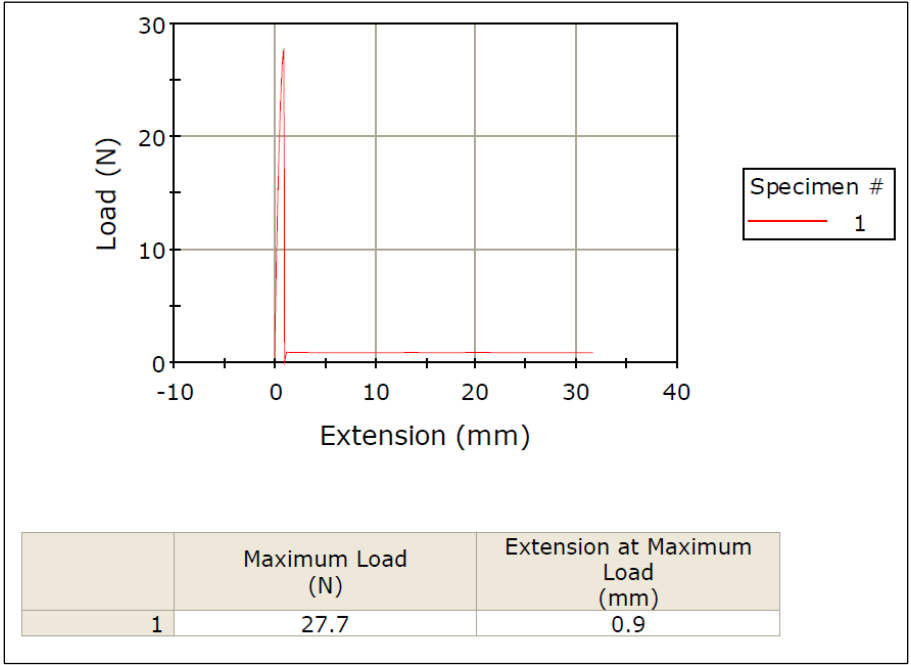

Figure 65: Sample 6-Load versus Extension

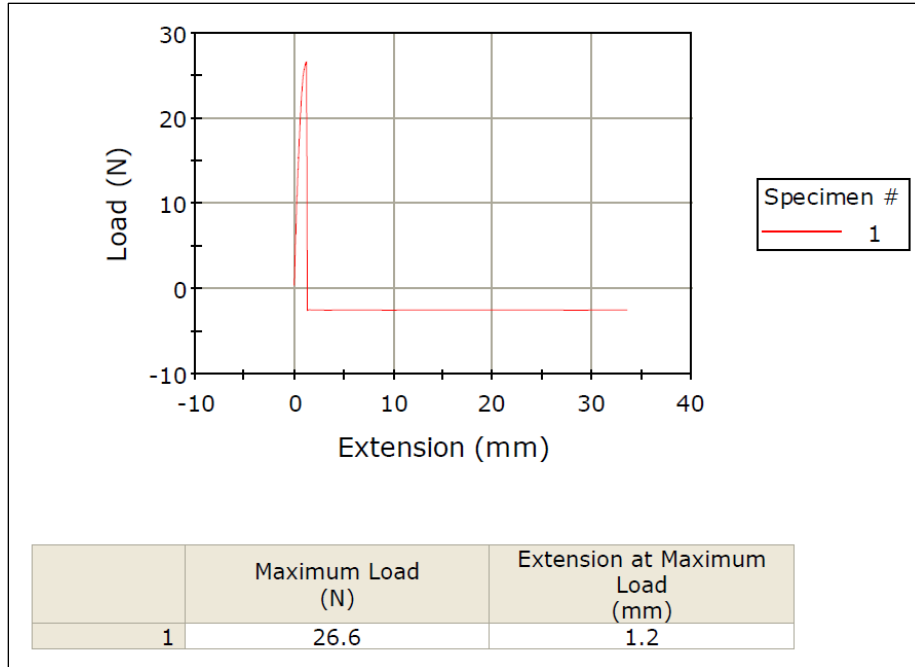

Figure 66: Sample 7-Load versus Extension

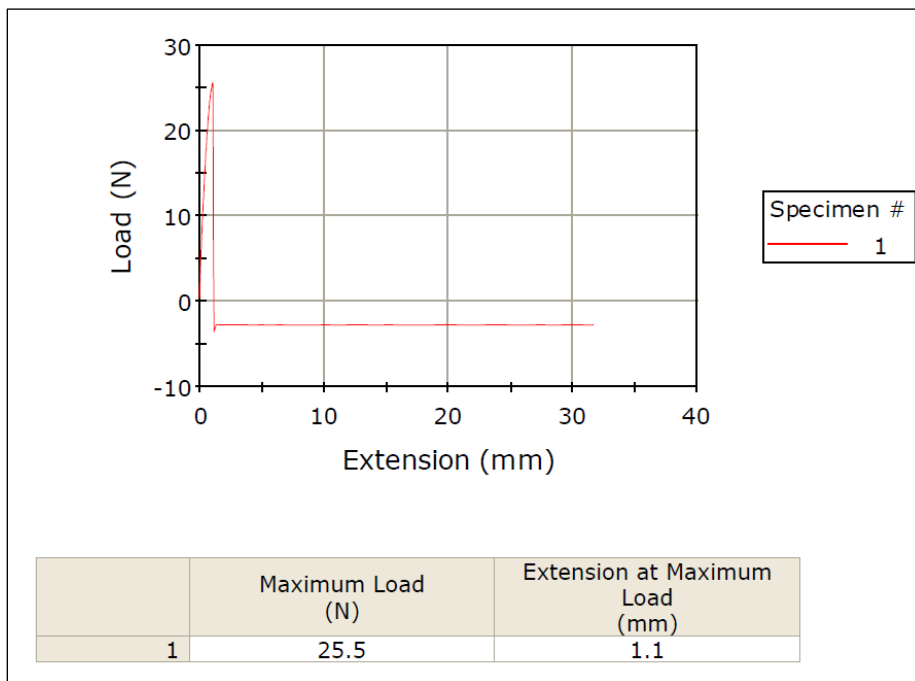

Figure 67: Sample 8-Load versus Extension

## Appendix E: Product Data Sheets

Specification	
Part Number	LW 031 06 0114S
Outside Diameter	0.288 in
Hole Diameter	0.312 in
Wire Thickness	0.010 in
Free Length	0.114 in
Rate	143.00 lb/in
Solid Length	0.030 in
Rod Diameter	0.200 in
Total Coils	3.0
Finish	PASSIVATE
Waves Per Turn	2.5
Material	17-7 PH
Radial Wall	0.032 in

Table 3: Lee Spring's Wave Spring Specifications



Figure 68: VXB Linear Bearings Specifications

<b>Performance</b>						
Maximum Duty Cycle	100%	50%	25%	10%		
Maximum ON Time (sec) when pulsed continuously <sup>1</sup>	∞	360	32	8		
Maximum ON Time (sec) for single pulse <sup>2</sup>	∞	470	120	32		
Watts (@ 20°C)	10	20	40	100		
Ampere Turns (@ 20°C)	1166	1649	2332	3688		
<b>Coil Data</b>						
awg (0XX) <sup>3</sup>	Resistance (@20°C)	# Turns <sup>4</sup>	VDC (Nom)	VDC (Nom)	VDC (Nom)	VDC (Nom)
23	1.96	536	4.4	6.3	8.9	14.0
24	2.69	600	5.2	7.3	10.4	16.4
25	4.89	840	7.0	9.9	14.0	22.0
26	8.70	1117	9.4	13.3	18.8	29.7
27	11.50	1260	10.7	15.2	21.0	34.0
28	19.20	1645	13.8	19.6	28.0	44.0
29	31.20	2104	17.7	25.0	35.0	56.0
30	49.60	2646	22.0	31.0	45.0	70.0
31	77.40	3280	28.0	39.0	56.0	88.0
32	119.00	4026	35.0	49.0	69.0	109.0
33	202.00	5317	45.0	64.0	90.0	142.0

<sup>1</sup> Continuously pulsed at stated watts and duty cycle

<sup>2</sup> Single pulse at stated watts (with coil at ambient room temperature 20°C)

<sup>3</sup> Other coil awg sizes available — please consult factory

<sup>4</sup> Reference number of turns

Table 4: Ledex Solenoid Duty Cycle

### Specifications

Dielectric Strength	1000 VRMS
Recommended Minimum Heat Sink	Maximum watts dissipated by solenoid are based on an unrestricted flow of air at 20°C, with solenoid mounted on the equivalent of an aluminium plate measuring 102 mm square by 3.2 mm thick
Coil Resistance	±5% tolerance
Holding Force	Flat Face: 61.5 N @ 20°C 60°: 29.4 N @ 20°C
Weight	197.3 g
Plunger Weight	45.4 g
Dimensions	See page 35

### How to Order

Add the plunger configuration number and the coil awg number to the part number (for example: to order a unit with a 60° plunger rated for 21 VDC at 25% duty cycle, specify 195226-227).

Please see [www.ledex.com](http://www.ledex.com) (click on Stock Products tab) for our list of stock products available through our North American distributors.

Figure 69: Ledex Solenoid Specifications



## 7. Bibliography

Cragun, John E. Lane Merger Apparatus. United States of America: Patent 5161665. 13 November 1992.

Glover, Charles G. Apparatus for Combining Articles from Plural Lanes into a Single Lane . United States of America: Patent 4265356. 20 August 1981.

Haan, Ted W. High Volume Conveyor Sortation System . United States of America: Patent 7128197. 8 June 2005.

Harris, William O. Parallel Shaft Drive and Index Machine. United States of America: Patent 5176036. 1993.

Keyser, Carl A. Materials Science in Engineering. Columbus: Charles E. Merrill Publishing Company, 1968.

"Ledex-Solenoids." 2011. Ledex. <<http://www.ledex.com>>.

"Lee Spring-Precision Stock and Custom Springs." n.d. Lee Spring. <<http://www.leespring.com>>.

"McMaster Carr." 2011. <<http://www.mcmaster.com/#>>.

"Media Info." 2008-2010. Geneva Wheel Design: A Wonderful Intermittent Motion Mechanism. 2011 <<http://www.meadinfo.org/2009/05/geneva-wheel-design.html>>.

"Newark." 2011. <<http://www.newark.com>>.

Shackleford, Geoffrey G. Gripper Mechanism. United States of America: Patent 4243257. 5 April 1979.

"Timing Belt Conveyors offer speeds up to 200 fpm." n.d. Thomas Net. 2011 <<http://news.thomasnet.com/fullstory/Timing-Belt-Conveyors-offer-speeds-up-to-200-fpm-451835>>.

"VXB Ball Bearings." 2011. <<http://www.vxb.com>>.

"Wise Tool Blog." 14 June 2010. [Type of Mechanical Stamping Presses and its Application.](http://www.wisetoolblog.com/type-of-mechanical-stamping-presses-and-its-application/)

2011 <<http://www.wisetoolblog.com/type-of-mechanical-stamping-presses-and-its-application/>>.