

WORCESTER POLYTECHNIC INSTITUTE

WPI's Bouldering Wall

Building a bouldering wall for the WPI community

Thomas Liu, Morgan Quirk, Daniel Nuzzo-Mueller, Felipe Polido, Richard La Mura, Evert Fairman

Contents

Abstract.....	3
Introduction	4
Meet The Team.....	5
The Beginning	7
Bouldering History	9
Campus Interest.....	10
Blog	11
Space.....	12
East Hall Bike Room	12
Squash courts in Harrington Auditorium	14
Funding	17
Adopt-A-Hold	17
Alumni.....	19
Student Government Association.....	20
President Berkey’s Support.....	20
Liability.....	22
Design.....	24
Construction.....	26
Plans for the Future	27
Conclusion.....	28
Acknowledgments.....	30
Bibliography	31
Appendix A – Liability Release Form.....	32
Appendix B – Letter to Alumni.....	34
Appendix C – Letter to Administration	35
Appendix D – Cave IQP Proposal.....	37
Appendix E – IQP Blog.....	45
Appendix F – Cave Climbing Manual.....	52

Abstract

The team planned and established a bouldering wall on campus for use by the WPI community. After assessing the interests of the student body, the group went about acquiring permission from the school; this involved securing a space on campus, raising necessary funds and addressing liability. The bouldering wall will be built over the summer of 2010 and will be open for use by the student body for many years to come.

Introduction



Our IQP focused on bringing the sport of rock climbing to the WPI campus and community. Our IQP group worked with administrators, contractors and the general WPI student body to make this bouldering wall a reality. We worked to poll interest in the project, acquire space and funding, and create a unique climbing wall that the WPI community could call its own.

Our IQP group met through our common interest in rock climbing. Five of the group members met several times a week in freshman year in order to go climbing at a local YMCA branch that had a climbing wall before the IQP was even initiated. The following year, our sixth member joined the WPI community and the Outing Club where the group fully formed. Over time we also participated in climbing competitions together and with the WPI Outing Club we began traveling to Rumney, New Hampshire in order to climb on real rock faces.

The group then went about constructing the IQP and performing research into liability, construction, safety, school policies, interest and space requirements. This research came from many places such as surveys, other schools' experiences with creating their own climbing walls, professional climbing wall companies and the school administration. Many challenges arose but in the end the team was able to secure space and acquire funding thanks to the interest on campus.

Meet The Team

Daniel Nuzzo-Mueller	<p>Daniel Nuzzo-Mueller is a Physics Major whose focus is on Alternative Energy. Daniel grew up in Boston and is part of the class of 2011.</p> <p>Daniel is a very large fan of climbing but sadly has found that schoolwork is taking priority to climbing as of late. Regardless he is still very interested in climbing and because of this he has dedicated himself to bringing a climbing wall closer to campus. Daniel is also an avid cyclist.</p>
	
Richard La Mura	<p>Richard La Mura, or RJ for short, is a junior at Worcester Polytechnic Institute, and hails from Rochester, NY. Having first climbed indoors during high school, he has always enjoyed heights. Since freshman year, climbing has joined technical theatre and ultimate Frisbee as an activity of choice. His favorite kind of climbing to this point would be outdoor sport climbing, which he loves to do in Rumney, NH. Being on top of a wall just looking out over the woods is something RJ finds absolutely wonderful.</p>
	
Felipe Polido	<p>Felipe is currently in his third year at WPI, pursuing a Robotics Engineering and Electrical & Computer Engineering double major.</p> <p>Felipe has been passionate about rock climbing for as long as he remembers; he initially fell in love with climbing on the beautiful cliffs of Brazil, where he is originally from. To Felipe rock climbing is a way of life, representing an inner search to personal growth and requiring absolute mental and physical commitment.</p>
	

<p>Evert Fairman</p>	<p>Evert Fairman hails from Saint Paul, Minnesota. A senior at WPI studying ECE, his professional interests include computer hardware design, signal processing, and biomedical instrumentation. When not at school, he can frequently be found rock climbing, playing the saxophone, reading non-fiction and spending time with his girlfriend in Vermont. Evert is very curious and always strives to expand his knowledge.</p>
	
<p>Thomas Liu</p>	<p>Thomas Liu is a Junior IMGD and CS double major. He was roped into the climbing culture his freshman year of college and climbs actively several times a week. Thomas is always looking to get more people interested in the sport, and believes that having a climbing wall, free of charge, on campus is a great way for students to get started.</p>
	
<p>Morgan Quirk</p>	<p>Morgan Quirk is a Junior IMGD / CS double-major at WPI. He became interested in climbing in his freshman year of college, focusing on bouldering more than top-rope or lead climbing. Morgan believes having an on-campus bouldering wall will get many more people interested in the sport and provide additional fitness/athletic options. He can be found in the lab at any time of the day or night, making or playing video games.</p>
	

The Beginning

Many of the members of the IQP team became interested in climbing shortly after coming to WPI. Felipe revived the Outing Club as a result of the interest our campus had towards climbing and other outdoor activities. The only climbing wall available to us at this time was the YMCA wall, which required us to pay every time we went climbing and was a mile away. This inconvenience prompted us to think about what it would take to build our own wall, as many schools in the area have successfully done.

Our original plan was to make a smaller wall with some specific technical features: lights on every hold to replace marking routes with tape, sensors to detect which holds are being touched, and a computer with custom software to tie these features together. Because this idea requires a wide range of engineering knowledge, we looked for group members from different engineering majors. The original 9 group members included students of Mechanical Engineering, Physics, Computer Science, Electrical and Computer Engineering, Robotics, and Aerospace. Eventually we discovered that getting approval for this more complicated wall would be significantly more difficult, so we returned to the idea of a simple bouldering wall.

Although we had been thinking about the project and discussing it internally for quite a while, we did not have our first meeting with any administration until the beginning of A-term 2009. We decided to directly meet with President Dennis Berkey as our first step; if he disapproved of the project, there would have been no reason to try to do it. During one of his office hours, we presented our IQP pitch and project proposal [Appendix D] to him. The result of the meeting was mixed – he seemed interested in the project but was concerned with its scope.

We used this meeting and several meetings with other members of the administration to try to determine what the first steps were to tackling liability, funding, and space for the wall. To allow us to

get these individuals involved in the process, we created a simple website with links to our plans, proposals, and a project blog. At the same time, we set up the project to be an official credit-worthy IQP. The fact that WPI encourages and values this sort of project was probably the only reason it has turned out to be so successful - it is unlikely we'd have the time or motivation to complete the project if it was being done in parallel with three other classes. Somehow, we were permitted to have a very large IQP group; initially we had 9 people on the project, although three members of our team left on account of other commitments.

Bouldering History

The sport of bouldering began as a form of training for rock climbers. Climbers would practice on small walls or boulders as a workout, but without grading the routes. Around the 1930s, bouldering became adopted as its own sport, incorporating many of the aspects of sport climbing. The popularity of bouldering as a sport has only grown since then, and there are leagues and competitions all around the world.

Bouldering is a sport which challenges the climber in several ways. Primarily and most apparently, it requires significant strength and dexterity. Upper-body strength is the most important for climbing, since a lot of the time is spent hanging from one's arms or moving with one's biceps and forearms. Dexterity and technique go hand-in-hand; the climber learns how to balance and position their body to most effectively move up or across the boulder problem. The word "problem" is generally used to describe a bouldering route because bouldering routes are both a mental puzzle and a physical challenge.

A fact that those unfamiliar with the sport might not be aware of is that focus and planning are critical to success in climbing and bouldering. If the person attempting a boulder problem does not correctly plan his route, he may find himself stuck with nowhere to go or attempting a very difficult maneuver. Additionally, if he lacks focus he may overshoot a move or completely miss a hold.

Clearly, climbing and bouldering are excellent activities for training the body and the mind. They also turn out to be great social activities, frequently inspiring the participants to communicate knowledge about the route or wisdom regarding technique. Many climbers enjoy playing add-on, a social game where players continually make a route longer and more difficult for the next climber. Overall, bouldering is a great sport for personal improvement as well as being a challenging and fun social activity.

Campus Interest

Our first step was to gauge campus interest. We believed that many students would love to have a bouldering wall on campus and that this fact could be used as leverage in asking administrators for permission to build a wall.

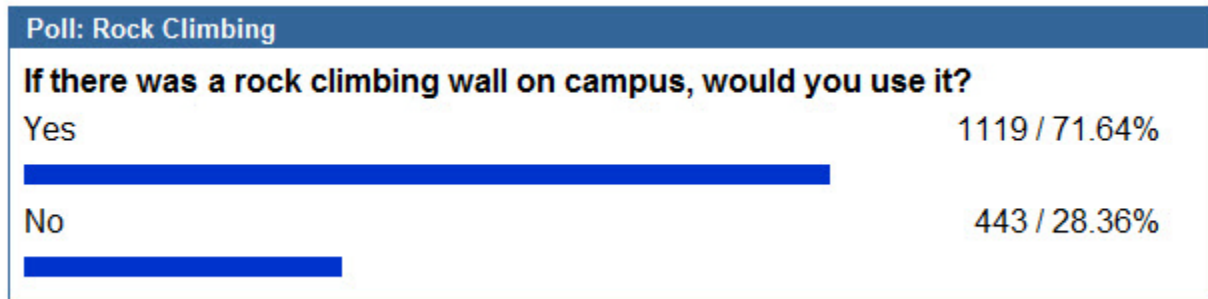

Figure 1 - The results of the myWPI poll.

We posted the following survey on myWPI: "If there was a rock climbing wall on campus, would you use it? Of the 1,562 students that answered the survey, an overwhelming 1,119, or 71.64% answered yes. This was a great sign that a bouldering wall would be treasured by students on campus for years to come.

Now that student interest was established, we began to think about raising money to fund building of the wall. One of our efforts was the Adopt-A-Hold program in which students were able to purchase engraved climbing holds. This program was particularly successful and we were able to raise 2,485 dollars directly from students over the course of a week of table sitting on the fountain. This large monetary contribution from students served as another indication that there was interest on campus. Over a hundred college students, historically known for being poor, were willing to contribute directly to a wall that they would look forward to using.

We entertained other forms of on-campus fund raising, including bake sales and t-shirt sales. We decided that bake sales would be unable to pull in enough revenue to be worth doing. We decided

that designing and selling a t-shirt was a pretty good idea but once Adopt-A-Hold was suggested we decided it was the best alternative.

It was clear that interest existed on campus, and we looked forward to satisfying this interest. Over the next year we would work hard to make the bouldering wall become a reality.

Blog

Around the same time as the Adopt-A-Hold project, we decided it could be beneficial to the IQP to start a web log on Blogspot.com. Keeping a log of our progress seemed like a good way to keep people on campus excited about the project. In addition, it would supply us with a timeline of the project as the process continued. In early June, we set up a blog and Morgan was tasked with keeping it updated.

When we discussed the project with faculty or students on campus, we would give them a link to the IQP website which directed viewers to the blog's website. In this way, we attempted to bring people into the process by allowing them to see the stages of development towards the goal of an on-campus bouldering wall.

The blog was updated with information about topics discussed in meetings, new unexpected developments, Adopt-a-Hold information and results, and so on. Writing this paper, the blog timeline has been useful in pinpointing the order of the tasks we undertook. Most importantly, we have used the blog as proof of our commitment to the goal of the project; we believe it shows that we are serious about getting the wall built. The blog can be found at <http://iqpclimb.blogspot.com> [Appendix E].

Space

One of our major concerns in planning this project was the issue of space; we needed a place to build the wall where students would have access and preferably a space where the wall could stand for years.

In the beginning of the project we looked all around campus for rooms that would fit our requirements. The ideal room would be at least 12 feet tall and would have enough floor space for several people to sit in comfortably. We discovered some odd areas on campus that we previously had no idea existed, but in the end a few places seemed ideal for our project.

East Hall Bike Room

At the time of our exploration the bike room in East Hall had a grand total of three bikes parked in it, using up less than 5% of the room. We proposed to Naomi Carton, Director of Residential Services, that we could use half of the room, a modest amount that would leave plenty of space for bikes in the rest of the room. In particular, this room was ideal because the ceiling was a good height and the room had doors directly to the outside already protected by smart card locks, making for easy access. Building in this room would require moving the sprinkler system up a few feet, since the pipes in the room were very low, but we were ready to finance the necessary changes.



Figure 2 - An image of the bike room we were considering.

Four months into the search, Carton let us know that WPI had a policy regarding making changes to buildings that had been built in the last 2 years, and we were forced to look for a different room.

Olin Hall

The third floor of Olin Hall is home to several clubs and organizations along with some storage for the Physics Department. The closets that the physics storage was in were built under a slanted ceiling that is a result of the roof. Fortunately, this slant would be a great feature for a bouldering wall! In addition, the I-beams in the roof would provide a good foundation on which to build a wall and this room seemed like a good choice.



Figure 3 - What appeared to be the home of our climbing wall, a.k.a. Olin Hall

We approached Professor Germano Iannacchione, Head of the Physics Department, and asked for his permission to use the room, and he tentatively did not reject the proposal. Later on in the project we returned to ask his permission once again and he gave his approval but warned that once we modified the room to make it livable (lights, heating, ventilation) the school could ask for the space for academic purposes. We decided that this was a threat that we were not concerned with and began to look at designing a wall to fit in the space.

Squash courts in Harrington Auditorium

The bouldering wall at MIT was built in an old squash court, and squash courts provide a more than adequate amount of space and an ideal height for building a bouldering wall. At WPI, the squash

courts are not used very often, but school administrators informed us that we could not use a squash court because WPI offers squash gym classes which use the space.

After Professor Iannacchione had given us approval to use the room, we reached out once again to the WPI administration. We sent an email [Appendix C] to all of the administrators that we had contacted since the beginning of the project in hopes of getting a concrete decision on whether or not we could begin construction. Their response was a great delight for the entire team. We were given permission to build the bouldering wall in a squash court in Harrington Auditorium, an ideal space for the wall.



Figure 4 - The room to be filled with a climbing wall

Our problems relating to space had disappeared and we were becoming closer to achieving our project goal. The search for a location for our bouldering wall took several months, beginning mid A term and ending with our acquisition of a squash court at the end of C term. This new space could accommodate a much larger bouldering area.

For most of B term it had seemed as though the bouldering wall would find its home in Olin Hall and we had compromised with Professor Iannacchione in order to attain the space. In approaching Professor Iannacchione we knew we had to tread lightly; Olin Hall is an academic space and we were requesting the space for non-academic purposes. We agreed to section off part of the space to be saved as Physics Department storage instead of as a new Outing Club closet as we had originally hoped.

From halfway through B term until just a few weeks before the end of C term it seemed that none of the school administrators that we had contacted were able to give us a final word of whether or not we could build the wall in Olin Hall. This prompted us to send the email that led to the acquisition of a squash court.

Funding

Building a climbing wall is not cheap. Early in the planning phases it became apparent that a substantial amount of money would be needed to complete the project. The original estimate from when Olin Hall was the prospective location came to around \$19,000. It should be noted that acquiring this kind of money for an Interactive Qualifying Project is not merely atypical, but almost unheard of.

Given the unlikelihood of finding a single source that could provide the entirety of the required funds, a multi-faceted attack was warranted. This included reaching out to the campus community through our Adopt-A-Hold program, petitioning the Student Government Association for funds, contacting Alumni for donations, and even going to the president of WPI, Dr. Dennis Berkey. In the end, the group was able to secure a sum in excess of \$40,000, enough to build a bouldering wall to adequately utilize the new space.

Adopt-A-Hold

Through the aforementioned campus-wide poll, it was clear that there was substantial student interest in having a bouldering wall on campus. The group therefore came up with the idea of selling personalized climbing holds that would comprise an integral part of the wall.

The general idea was that a student could select the hold he wants to adopt, and then select the word, image, or brief statement he wanted the hold to be personalized with. The actual personalization of the holds would be done by burning the messages into the holds with a soldering iron – a rather primitive but tested method that seemed to work well. The cost of adopting a hold was set at the price of the hold itself plus a small premium, averaging around \$5. In this way, the holds, which make up a substantial percentage of the total cost, could be effectively paid for.



Figure 5 - An engraved climbing hold

Carrying out this idea, the group preselected a number of holds that we thought would be both useful for a climbing wall and appealing to potential contributors. These holds represented a wide variety of shapes, sizes and prices. We then set up a table next to the campus fountain and sold holds for four days during B-term 2009, advertising the event via campus-wide email. Because we were not able to afford the holds before money was acquired, a poster was drawn up showing every possible hold that prospective donators could adopt (see below).



Figure 6 - One of the posters containing Adopt-A-Hold holds

The Adopt-A-Hold program turned out to be a resounding success that greatly surpassed everyone's expectations. In only two weeks, more than 150 holds were sold and revenues surpassed \$2,200. Some of the messages that were created by donators included "Analog Rules!" and "Mount Everest". As of this writing, the actual ordering of the holds is underway and an event is being planned during which contributors can personalize their own holds. This event will be partially to inspire additional interest, and partially because burning words into holds is a laborious, time-consuming process, so it is in our own interest to get others to do this work if they are willing.

Alumni

A logical source of money for school-related activities seemed to be donations from alumni. In order to do this, the group approached the WPI Office of Alumni Relations about sending out a letter requesting funds from WPI graduates. The process of reaching out to WPI alumni is currently underway

and a letter [Appendix B] has been sent targeting former members of the outing club. Unfortunately, response has been slow-going and so far no donations have been received.

Student Government Association

Though the Adopt-A-Hold program was a resounding success, we knew that the majority of the money would have to come from a more lucrative source. Since the Student Government Association (SGA) has a large budget to spend throughout each year, we thought it would be worthwhile to ask. Getting acquainted with the political process, it was found that the best way to go about this was to approach student representatives individually to garner their support before officially asking for money in front of the entirety of SGA. Since the beginning we worked hand in hand with several SGA members including the current Treasurer, Vice President, and President in order to assure their support. We had the support of the WPI community and the SGA Mission Statement says: *“The Mission of SGA is to improve the quality of undergraduate student life at the University both academically and socially by addressing student needs and concerns, providing financial structure of WPI's student clubs and organizations, and representing the student body in a professional manner.”* Because of this we managed to raise \$20,000 directly from SGA.

When we pursued SGA's support we submitted a Senator Sponsored Request, also known as a SSF. This request was approved by the financial board of the Student Government Association and then the SSF finally passed on Tuesday April 27th at the Senate meeting where the request met almost no resistance. This solidified SGA's contribution to the project and allowed the climbing wall to become a reality.

President Berkey's Support

In the past month, the project has gone from building a small wall in the attic of Olin Hall to having an entire squash court in the Alumni Gym. Although the money from SGA and the Adopt-A-Hold

program would be enough to cover the former project, having a larger room now means we can be more ambitious about the size and quality of the wall we are building. In order to fully take advantage of the allotted space, an additional \$20,000 would be needed.

It was for this reason that we decided to speak to WPI President Dennis Berkey about the matter. We knew that he had what is essentially a “slush fund” with which he could support any school project he pleases, so the obvious path is to simply show up to his office hours and attempt to convince him that a bouldering wall is a project worthy of WPI’s money.

In short, the group did exactly that, and he responded extremely positively. He agreed to match any funding provided by SGA up to \$20,000, which brings the group past the desired goal of \$40,000.

Liability

An important part of building the bouldering wall was working with the liabilities that are connected with operating a bouldering wall. While bouldering is a sport that does not necessarily pose a risk that is any greater than other sports there is still the possibility of injury.

We researched the liability that other bouldering walls deal with in order to understand the wording and the extent that the liability coverage extended to in the case of other bouldering walls. We investigated as to who would ultimately be responsible for the wall and we learned that the liability of the wall not only extends to when people are climbing it but also the security of the wall when it is not in use. The WPI administration informed us that any climbing wall would need to have set hours so that it could not be accessed when there was not a trained individual overseeing proper use of the bouldering wall.

We also looked into the need of a liability form [Appendix A] that participants must sign in order to release the wall operators and the owners of the wall from any form of responsibility if a climber hurts themselves due to their own fault. To give ourselves a starting point on the liability form we took samples of liability forms from Metro Rock, Boston University, Massachusetts Institute of Technology and the local YMCA branch. All of these helped us construct a liability form. In addition, we needed to create an Operations Manual to instruct staff members on standard bouldering wall procedure and possible operational hours [Appendix F].

The liability of the wall in general has been an intensely discussed topic both amongst ourselves and the administration we have talked to on Campus. Since the wall is on WPI property the school would be responsible for the wall and any accident that may occur there.

Overnight security for the wall will be managed by campus security since the wall will be in a locked building and have a locked door protecting it. Any un-authorized use of the wall will be strictly prohibited and would require anyone who wishes to climb outside of scheduled times to actively attempt to break into the room.

Design

During the early stages of our project, it was decided that we would be given the space in the third floor of Olin Hall. This room had to be cleaned out and had neither heating nor sufficient lighting for a climbing wall. The slant of the roof was also built into two sides of the room. Originally we examined the viability of having WPI's contractor build the climbing wall in the room, in addition to adding heating and lighting.

Mr. Dave Mann, WPI's contractor, looked over the room and gave us an estimate for all the work we asked of him. His estimates for heating and lighting were normal and he agreed to do that part of the project. Unfortunately his company had little to no experience building climbing walls, which led to a declination of our project. This allowed us to begin searching for companies to build the wall outside the school. Our search for climbing wall companies led us to find the locally centralized Rockwerx, which built Central Rock Climbing Gym in Worcester, as well as Boston University's wall. After deciding on Rockwerx, we talked to the administration to be sure that we could hire an outside company to build the wall.

The unique space we were given inspired an interesting design, which incorporated the slanted roof into our wall. Since there was already a frame sitting in front of us we decided to use that frame to reduce costs and complications in building.

Rockwerx agreed with us after sending an associate to see the space, and even suggested that the price of the wall could be reduced, since there needed to be far less engineering and design done by their team. This design also reduced the build time for the wall, given that a frame didn't need to be constructed.

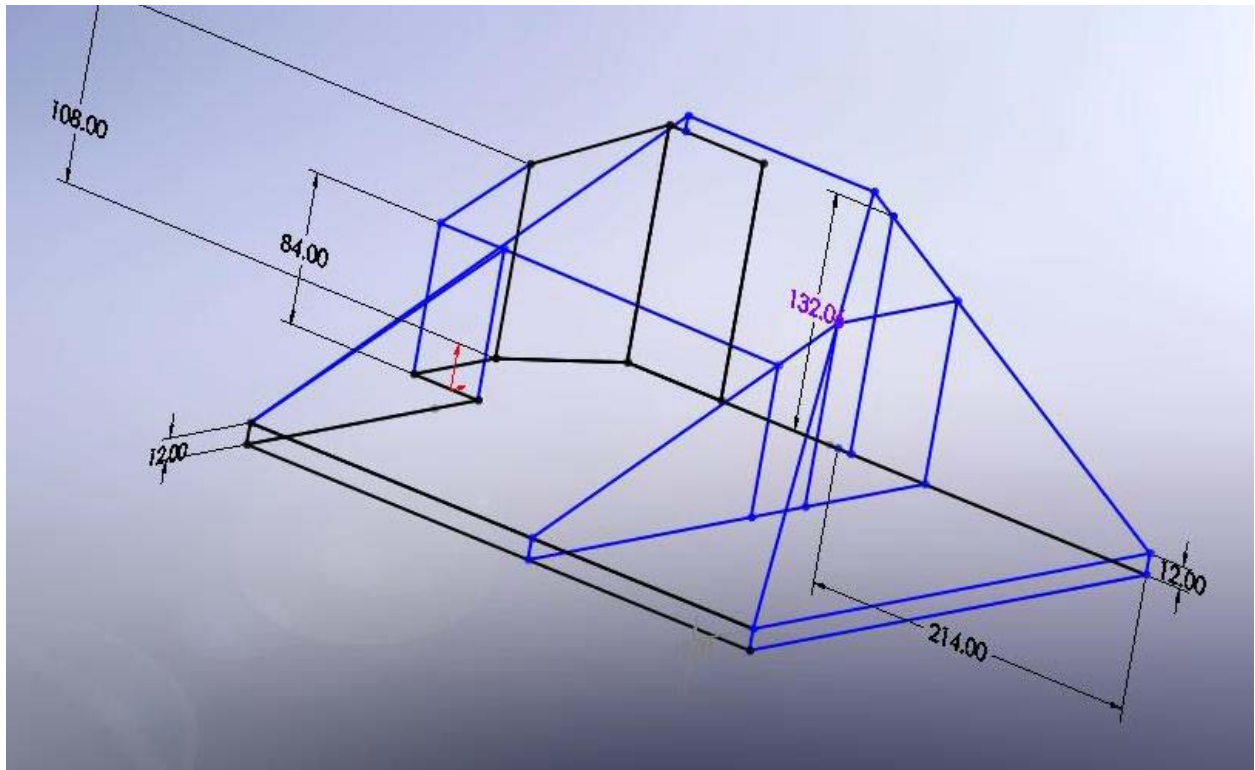

Figure 7 - The design of Olin Hall

Now that our space has changed to a squash court (222" x 382") in Harrington, our wall can be much larger, and needs to be redesigned. Rockwerx is still going to be building the wall, but it appears as if more of the design will come from them since such odd limitations are not set by the room. We no longer need to have heating or lighting renovated, which is quite fortunate, and we are excited to get the wall built. In addition with the greater room space the dimensions of the wall can be expanded.

We have mocked up proposed designs of the wall in 3D modeling programs which will be used in our final discussions with Rockwerx. Our vision of the bouldering wall includes a flat wall for beginners, several slanted walls which are great for training and an arch which is a unique and interesting addition.

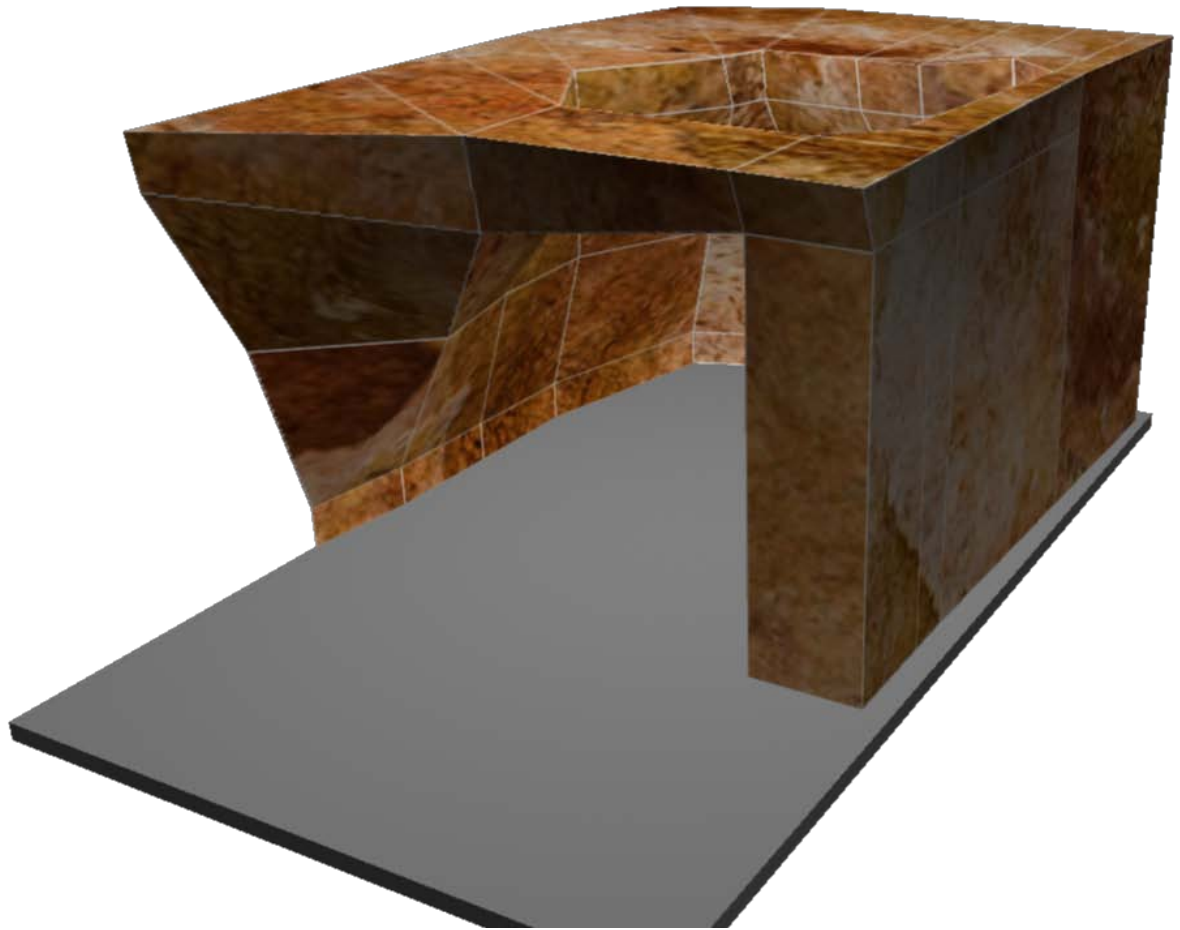

Figure 8 - A concept model for the squash court, modeled in Autodesk Maya

Construction

Rockwerx will be building the wall in the Harrington Auditorium squash court over the summer of 2010. The wall will be freestanding, with a super structure of welded steel. On top of the steel, Rockwerx places high grade plywood panels, coated in a fibrous cement to give a rock texture. In addition to the wall we will be installing foam padding on the floor to protect climbers. Once the wall is built the team will be installing holds, setting routes, and organizing a schedule to keep the wall open throughout the school year.

Plans for the Future

Our plans for future management of the wall once it has been built are to pass responsibility of the wall off to the WPI Outing Club, which will be in charge of appointing staff and managing the wall. As far as wall maintenance is concerned, Rockwerx has a policy of inspecting all of the walls they constructed every two years.

Our plans were for the wall to be managed by staff members, who will be trained in First Aid and in spotting technique. The wall will never be opened without a staff member present and staff members will open the wall for some predefined hours each week. In addition, staff will be able to post on the Outing Club website other times that they plan to open the gym.

All new climbers will have to sign a liability release form and then sign in, and these documents will be kept on file by the Outing Club. Climbers will be allowed to use or rent shoes that are available in the bouldering room.

The group has been considering two different ways to pay for purchasing new shoes and future wall maintenance: either charge a small fee for renting shoes (around \$1) or charge a single one-time fee (around \$5) when the climber signs his or her liability release form. Either of these plans will be able to pay for most or all of the necessary upkeep of the wall and a decision will be reached before the opening of the wall. These policies will be modified as needed in the future.

Conclusion

Two years ago, we conceived of giving a bouldering wall to the community of WPI. Although there have been moments of serious doubt, that goal is now all but accomplished. We have the required administrative permission, the necessary funding, and a large student following awaiting the wall's completion. In just a few short months, the wall will open and become both a unique hangout for campus rock climbers and a means for others to become interested in the sport.

Through surveying the campus, we established that a strong campus interest in this project exists. Using this data and our ever-present charisma, we managed to acquire support from the necessary school administrators, including President Dennis Berkey. We generated additional support among the student body with an article in the WPI newspaper, as well as our Adopt-A-Hold program.

The Adopt-A-Hold program also served as one of the main channels of raising funds for the project, through which we obtained over \$2,400. We also petitioned the Student Government Association, who voted (almost) unanimously to give us \$20,000. An additional \$20,000 came from President Berkey, who matched the funding from SGA. All told, we managed to raise over \$42,000, enough to build a wall of the highest quality.

As for space to build the wall, we tried a number of locations, including the bike room in East Hall and the attic in Olin Hall. In the end, Janet Richardson came through and gave us a squash court in Harrington Auditorium, which bested all other prospects. In order to make the most of this generous space, we are hiring Rockwerx, noted Massachusetts climbing wall contractors, to construct the wall during the summer of 2010.

Lastly, we have put together a detailed plan concerning the general management of the wall in the future. This includes rules for the wall manager, as well as for the climbers themselves. We have also put together liability waivers and a plan to continuously fund the wall by charging students per use.

The project was successful; although discouraging at times, the arduous task of opening our fair university to the sport by installing a bouldering wall on campus has been accomplished. As a result of the backing of the community, support of the administration and our boundless enthusiasm, there will be an exceptional wall on campus. This wall will be filled with the creative expression of those who have made this project possible, becoming a legacy for our community.

Acknowledgments

The WPI bouldering wall would not have become a reality without the dedication of our loyal supporters; the effort and interest from a variety of students, administrators and faculty towards our project was essential to our success.

We would like to offer great gratitude to all the involved WPI Administrators, which whom without the WPI Bouldering wall, and our IQP in this matter, would not have become a reality. We would like to especially thank Alfredo DiMauro, Michael Curley, Janet Richardson, Dana Harmon and John Orr for strongly supporting us.

Next, we would like to acknowledge the collaboration from the Student Government Association; throughout the whole project we worked hand-in-hand with SGA members in order to understand their concerns and assure their support.

We would also like to demonstrate great appreciation for President Berkey, who supported us since the start. And, when the time was right, gave us concrete assistance for the realization of the project. Without his commitment the accomplishment of our project would have been rather dubious.

Finally, without the interest and commitment of the WPI Community as a whole we would not have had a true reason to pursue a bouldering wall on campus. Therefore we grant our utmost acknowledgement to the WPI Community for repeatedly reaffirming the need of our project. Particularly for those who contributed through the Adopt-a-Hold fundraiser.

Lastly, we would like to thank Sanado Barolli, Katrina Crocker and Karl Gibson for being great partners and even better friends.

Bibliography

MITOC Board of Directors. (n.d.). *MIT Climbing Wall Operating Manual*. Retrieved 9 21, 2009, from MIT.edu: <http://scripts.mit.edu/~mitoc/wall/img/operatingmanual.pdf>

Nicros. (n.d.). *NICROS, Indoor Rock Climbing Walls, Climbing Holds, and Climbing Equipment*. Retrieved 4 12, 2010, from NICROS.com: <http://www.nicros.com>

RIT. (n.d.). *RIT Red Barn Climbing*. Retrieved 4 12, 2010, from RIT.edu: http://www.rit.edu/studentaffairs/ciar/interactiveadventures_rockclimbing.php

Rockwerx. (n.d.). *Solid, High Quality Gym Rock Custom Climbing Wall Systems from Rockwerx*. Retrieved April 10, 2010, from Rockwerx Climbing: <http://www.rockwerxclimbing.com/3484.xml>

Appendix A – Liability Release Form

Liability Release, Waiver, Discharge and Covenant Not to Sue

This is legally binding Release, Waiver, Discharge and Covenant Not to Sue (collectively, “Release”), made voluntarily by me, the undersigned Releasor, on my own behalf, and on the behalf of my heirs, executors, administrators, legal representatives and assigns (hereinafter collectively, “Releasor,” “I” or “me”, which terms shall also include Releasor’s parents or guardian, if Releasor is under 18 years of age) to the Worcester Polytechnic Institute (“WPI”).

As the undersigned Releasor, I have read and understood the rules of the Climbing Wall. I fully recognize that there are dangers and risks to which I may be exposed in utilization of the Climbing Wall. I also acknowledge the risks involved in climbing without a helmet, and I personally accept any risks resulting in not wearing a helmet.

As the undersigned Releasor, I understand that WPI does not require me to participate in utilization of the Climbing Wall, but I want to do so despite the possible dangers and risks and despite this Release. With informed consent, and for valuable consideration received including assistance provided by WPI, as the undersigned Releasor, I agree to assume and take on myself all of the risks and responsibilities in any way arising from or associated with this activity, and I release WPI and all of its affiliates, divisions, departments, and other units, committees and groups, and its and their respective governing boards, officers, directors, principals, trustees, legal representatives, members, owners, employees, agents, administrators, assigns, and contractors (collectively “Releasees”), from any and all claims, demands, suits, judgments, damages, actions and liabilities of every name and nature whatsoever, whenever occurring, whether known or unknown, contingent or fixed, at law or in equity, that I may suffer at any time arising from or in connection with the activity, including any injury or harm to me, my death, or damage to my property (collectively “Liabilities”), and I agree to defend, indemnify, and save Releasees harmless from and against any and all Liabilities.

As the undersigned Releasor, I recognize that this Release means that I am giving up, among other things, all rights to sue Releasees for injuries damages or losses I may incur. I also understand that this Release binds my heirs, executors, administrators, legal representatives and assigns, as well as myself. I also affirm that I have adequate medical or health insurance to cover any medical assistance I may require.

I agree that this Release shall be governed for all purposes by Massachusetts law, without regard to such law on choice of law.

I have read this entire Release. I fully understand the entire Release and acknowledge that I have had the opportunity to review this Release with an attorney of my choosing if I so desire, and I agree to be legally bound by the Release.

THIS IS A RELEASE OF YOUR RIGHTS, READ CAREFULLY AND UNDERSTAND BEFORE SIGNING.

(Releasor's Signature)

(Print Name)

(Parent's Signature, if Signatory is minor)

(Print Name)

(Date)

Appendix B – Letter to Alumni

Letter of Request for Funding

We represent a group of WPI students who are working with several companies, student organizations, and the administration of our school to build a rock climbing wall on our campus for the benefit of the WPI community.

Building a climbing wall is a very challenging task and one of the major challenges is the funding of the materials needed to build the climbing wall. A wall like this requires large amounts of good and special custom built hand holds. On top of just the material costs are also the costs associated with the proper construction of the wall.

The wall that we are looking to build, while small, will cost us around 18,000 dollars. We have already succeeded in raising all of the money for the holds on the wall through allowing WPI students to buy and personalize the holds. This fundraising strategy where contributors can leave a personal mark on the piece of hardware that they fund has raised 2,400 dollars. We still need to raise several thousand more dollars though in order to make this climbing wall a reality.

We would like to ask your organization if there is any amount of assistance that you could lend us in this respect. If you do find it to be in your interest to help us fund this wall your organization will be given a plaque that will be mounted either on the wall itself or in the immediate vicinity of the wall to honor your contribution to it's construction.

Appendix C – Letter to Administration

Dear WPI Administrators,

On behalf of the CAVE IQP Team, I would like to thank all of you for taking the time to meet with us regarding the building and implementation of a bouldering wall at WPI. We are contacting you once again so as to progress forward with the project and update you as to its current status. From our inception of the idea almost two years ago we have come a long way, but there is much to be done and we would like to address everyone's concerns. Since some time has elapsed since speaking with many of you, I would like to share with you our current standing of the project.

To establish the demand for a climbing wall at WPI: the results of our myWPI survey reveal that 72%, or 1,119 students voted they would love to use a climbing wall on campus. Reconfirming this interest, we raised earlier this year \$2400 from students, clubs, organizations, and faculty, towards holds for the wall. The holds will be personalized with messages and symbols, creatively authored by contributing students and organizations, and thereby becoming a mural of the WPI community.

From the onset of this project, we were able to partition our major obstacles into the categories of (one) liability, (two) financial needs, and (three) space. With respect to the first component, liability, we have worked hand-in-hand with Mr. Michael Curley, and although small details have to be worked out, the project has met his approval.

Addressing the financial aspect, a rough estimate for the realization of the project is around \$20,000. This number is based on an estimate from RockWerx to build the wall, combined with an estimate by a facilities-appointed contractor to renew the space. (RockWerx is a major climbing wall manufacturer in Central Massachusetts that has successfully built bouldering walls at colleges and universities such as Boston University.) We have also worked closely with the SGA to assure their financial support. We have additionally worked with the Alumni Offices, who has generated a list of 122 Alumni that were previously Outing Club Members and that could possibly contribute. To reiterate, we did raise \$2400 directly from the student body. However, although all this has been organized, we nevertheless can't take any further action since we don't have a formal approval for the location of the bouldering wall.

This leads us to our third obstacle; space. After several inquiries regarding a campus location for the bouldering wall, we were able to locate a small space on the third floor of Olin Hall that we found to be suitable. This space is currently being used as storage. It has very tilted walls, which are beneficial for our purpose though generally not a valued feature; also, no heating or windows are present in the room. Professor Germano S. Iannacchione has agreed with us that a transformation of the space could be allowed on the condition that an academic need for the space is not foreseen in the near future.

At this point we are uncertain as to how best to formally proceed. please keep in mind the only reason we dedicated all of this effort to this project is because it would ultimately benefit the WPI student body and meet the demonstrated interest. We wholeheartedly believe this bouldering wall will self-sustain into the future for the continuing benefit of students, faculty, and staff to come. Bouldering is a very social and cerebral activity; it is a sport which creates strong, trust-based relationships; it also provides an effective workout for both mind and body. In fact, we invite you to partake in our weekly indoor rock climbing sessions--we have utmost confidence that you will honestly enjoy it!

Please understand that we are contacting everyone involved in the design and implementation of this bouldering wall since we need to come to a resolution about the future of this initiative. We would like to hear everyone's opinion and concerns in relation to the project so that we can respectfully and professionally accomplish this ambitious project goal.

Importantly, we, the IQP CAVE Team, would also like to offer sincere thanks and appreciation to everyone who has supported us thus far. We look forward to your prompt reply and we thank you for your continued support.

Sincerely,

Felipe Polido, on behalf of the IQP CAVE Team

Climb on,

Felipe Polido
631 903 1322
Robotics Engineering WPI 2011
President of the Outing Club

NOTE: links to some major components of our project are as follows:

Project Proposal:

<http://oc.wpi.edu/cave.pdf>

Tentative Operational Manual:

<http://oc.wpi.edu/CAVE%20Climbing%20Wall%20Operating%20Manual.pdf>

Liability Release Form:

<http://oc.wpi.edu/Liability%20Release.pdf>

Appendix D – Cave IQP Proposal

CAVE

Computer Aided Vertical Experience

An On-Campus IQP Proposal

Students: Felipe Polido, Thomas Liu, Morgan Quirk, Karl Gibson, Sanado Barolli, Evert Fairman, Jay Lanzafane, Dan Nuzzo-Mueller, RJ LaMura

Advisor: Carolann Koleci

Contact Info: iqpclimb@wpi.edu

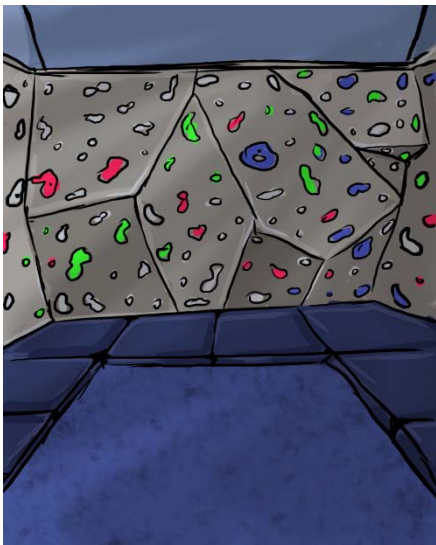

Abstract

The CAVE is a conceptual design for a hi-tech indoor bouldering wall on campus. A bouldering wall is a rock climbing wall that is not high enough to warrant ropes or gear other than floor padding. This wall would be small enough to fit in an existing room at one of WPI's athletic facilities. The technological design aspect of the project facilitates use of the wall by a lighting matrix to enhance the climbing experience. This proposal illustrates the motivation for constructing the wall, identifies its use and projected popularity on campus, and details any difficulties that may be encountered. It also covers legal issues such as insurance policies, liability of WPI, proper staffing, and safety regulations for the wall.

History

Rock climbing is a sport commonly believed to be quite dangerous. While it is true that mistakes can lead to serious injury, climbers are very careful and prepared. In a controlled environment like a climbing gym, safety is the primary concern; as a result, the risk involved with rock climbing is low. But even climbing in an indoor gym still involves a rope, which can be unnerving to some and a hassle to others.



Bouldering is a rapidly growing offshoot of rock climbing which involves climbing low walls (usually less than 15 feet high) without ropes or other gear. Bouldering started as a way to train for climbing, but quickly turned into a sport for its own sake. These days, bouldering competitions are held all around the world and bouldering walls have become commonplace in many gyms. Climbers can either climb to the top of a wall and simply jump down when finished, or they can *top out* by climbing over and onto the top of the wall. In either case, the fall is low enough that the padding prevents injury. This removes the potential danger of height and ropes while presenting a unique and more technical approach to the sport.



The student-built bouldering gym at RPI.

Rock climbing in general creates a friendly atmosphere in which people are brought together. Its man

versus nature conflict means that climbers work together to tackle a common problem, and it focuses on self-improvement rather than direct competition. Climbing also fosters a great deal of trust between people -- each climber must completely trust their belayer or spotter to avoid injury. Such a reliance between climbers helps create great friendships and contributes to this friendly atmosphere.

The safety and convenience of bouldering allows new participants to get involved with climbing without having to worry about the high cost of gear or potential injury. No ropes are involved -- the only needed preparation is a pair of climbing shoes. The workout achieved in bouldering can be even more intense than sport climbing. In one day, a climber could *send* (complete) three to four outdoor walls or, alternatively, dozens of bouldering routes in as little as a few hours.

Community

Climbing as a sport can have several physical as well as psychological benefits. The sport as a whole aims to achieve a balance of focus, flexibility, coordination and strength. The most apparent but not necessarily the most important is physical strength. Strength in climbing is important to success but can be partially made up for by other skills. In fact, it is preferred that someone new to climbing is not particularly strong so that they can develop their other skills and not simply brute force their way through climbs. Balance and flexibility are critical to successfully completing a route; difficult climbs rely increasingly more on advanced techniques.



The RIT Red Barn bouldering gym.

Focus also plays a big role in climbing, if not the biggest. For a difficult route, a climber needs to prepare, understand and plan out what they are going to do or risk running out of steam midway through the climb. This is especially true for bouldering where climbers often bring themselves to their physical limits attempting to send a route. Failing to send a boulder problem results in the climber rethinking their approach to it rather than engaging in more physical training and usually in success on their second or third attempt. Climbing and bouldering are constant problems that need to be solved and resolved

with one goal in mind, self-improvement.

Climbing creates a very relaxed and easy-going environment where people can pace themselves completely and do as much or as little as they want to. This makes it a very easy sport to get into, especially for people that don't usually participate in sports. In addition, the goal of climbing is not to compete with other climbers, but to get everyone up the wall. This creates a great spirit of cooperation; experienced climbers provide *beta* (specific advice on a climb) to others before and during their climbs. Many notice significant improvements after as little as a week or two and continue to improve so long as they keep climbing. Rock climbing is one of the most physically intensive sports around, comparable to other sports that work an athlete's entire body, such as swimming.

WPI Interest

The question of community interest in this project has come up, and we have already gathered some data to address it. During A-term we created a poll on MyWPI to try to gauge interest. Our question was, "If there was a climbing wall on-campus, would you use it?" Overwhelmingly, the WPI community embraced the idea: 71.64% of those who voted (1,119 students), voted that they would use it.

To judge the project's potential benefit to the community, we have looked at the recent success of the WPI Outing Club. The club had been recreated from scratch at the beginning of the 2007/2008 school year, and now runs weekly trips mountaineering, hiking, rock climbing, and so on. The outing club has nearly 200 members on the mailing list, and our meetings have had as many as 60 attendees. Every week, we walk with at least a dozen members to the local YMCA, located over a mile away, to climb on their climbing wall at \$5 per person. We believe a local, free, bouldering wall would have significantly more attendance. We also hold twice a week workouts at the alumni gym, and *slacklining* (essentially tightrope walking) on the Quad when weather permits.

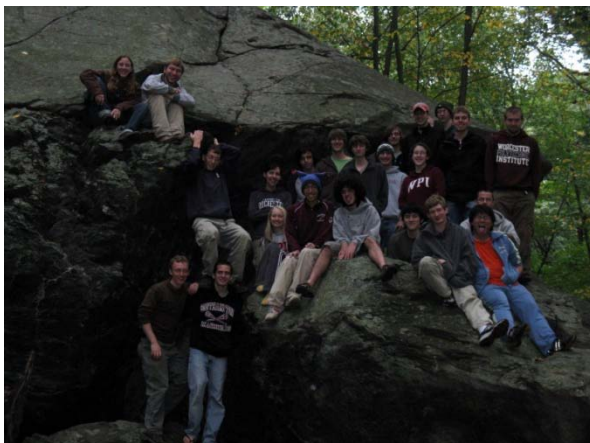

The WPI Outing Club at climbing events this year.

Left: outdoor bouldering at Lincoln Woods in Rhode Island.

Right: rock climbing wall at Worcester's central branch YMCA.

It should also be noted that most outing club members were not previously involved or interested in sports or other organized physical activity. We estimate that many more students will become interested in climbing or other sports if the CAVE is to be built.

Concept

There are many schools which have already developed climbing walls on their campuses, some of the more notable schools being Rochester Institute of Technology, Rensselaer Polytechnic Institute, Harvard, and Massachusetts Institute of Technology. In 1984, students at Rochester Institute of Technology began developing their gym in an abandoned barn on campus. By 2006, RIT decided to open their wall to people outside of the RIT community. They charge admission per day or per quarter, with a discount to individuals with RIT IDs. They also rent climbing shoes at \$2 per pair. Using this money, they have been able to keep their gym open for the past twenty-four years. Currently, the gym is open every weekday for five hours.

Rensselaer Polytechnic Institute's climbing gym is fairly new, and they are beginning to train a climbing team to bring to competitions in their gym. The gym is open whenever volunteer students are around to watch it, and is free to the Rensselaer Polytechnic Institute community, although it is mainly intended for their outing club.



A bouldering wall under construction.

Harvard keeps their new gym open for six hours daily, and charge admission per day or semester, as does RIT. Staff watches the gym; some of the staff are students themselves. They also have two older gyms on campus, one of which is a small training gym. Harvard holds competitions in the new gym.

The most influential model for the CAVE is the MIT climbing wall. MIT's wall was conceptualized, constructed and funded by MIT students entirely in 2000. All aspects of the wall were handled by the MIT Outing Club, including insurance and liability issues. Their wall is staffed by students who are trained in first aid, CPR, and wall safety procedures. The wall was inspected for safety by a professional

company when it was first built, and is also inspected by the wall staff every semester. Their main method of raising money to maintain the wall is by renting climbing shoes to climbers there. The wall itself is free of charge to use, but climbing shoes are all but necessary to climb. The wall is also used by MIT's physical education staff for climbing lessons, so students can earn PE credit through the wall.



The student-built MIT bouldering wall.

In MIT's case, they were given an unused squash court to convert into their wall. Other places, such as the local YMCA in Worcester, have also converted their squash courts into climbing walls. A squash court is an ideal place for a small climbing wall -- it is indoor, closed, can be locked off, and of ideal size and height. The total cost of the MIT wall's construction was about \$6,000, which includes lumber and hardware (\$1,500), climbing holds(\$1,500), floor padding (\$2,000), and liability costs (\$1,000). Maintenance costs are low enough so that they are covered by the shoe rentals.

Liability and Safety Procedures

While bouldering is relatively safe, lackluster protection and wall procedures can lead to injuries. As thus, CAVE will follow a number of standards to keep climbers safe.

The ground will be padded with at least four inches of padding akin to tumbling mats found in a gymnasium. In addition to this, there will be several crash pads that can be moved around the wall to arrest falls in specific areas of the wall. We will provide adequate fall protection meeting the America Society for Testing and Materials (ASTM) standards for construction and placement of playground equipment. The wall will be inspected before each use for loose and broken holds. Unofficial monthly structural inspections will also be held. We will consult a structural engineering company to ensure that it meets safety standards for climbing walls.



A spotter stands ready to guide a boulderer onto a crash pad should they fall.

Climbers should never climb alone. A spotter stands behind and below the climber out of way of the wall in order to prevent a climber's head from hitting the ground. Unsupervised use of the wall will be prohibited. The wall will be locked unless a member of the wall staff is present to supervise. Wall staff will be trained in CPR, First Aid, and basic wall procedures. Each climber will be required to sign a liability waiver before they climb for the first time.

Technological Component

Typically, indoor climbing and bouldering consists of acrylic rock holds bolted into a wall in intricate patterns. A climbing *route* is specifically a set of holds that can be used to get to the top of a wall, often marked by colored tape. Routes vary greatly in difficulty, and are rated on a scale from V0 to V16, with V0 being the easiest. Routes make it possible to have many different paths to climb on the same wall.

The CAVE will replace the traditional method of using colored tape to mark specific climbing routes with a computer-controlled lighting system. Each climbing hold will be transparent. Each possible hold position will be wired to a 3-color RGB LED, so that each hold can change to any color at any time. There will be a computer console at the wall that will control the LED matrix, allowing climbers to display specific routes at certain times and staff to program in new routes at any point with minimal effort. Given the size of the wall, the matrix would likely end up being about 16x16 lights, giving 256 individual 3-color LEDs. This project would require technical knowledge from multiple fields to create, such as electrical computer engineers, mechanical engineers, and computer scientists. The total estimated cost of adding the lights and computer console is roughly \$2,000 -- \$500 in LEDs, \$500 in wiring, \$600 for electronics and hardware, and \$400 for a computer console.



Concept images for what the CAVE might look like at completion.

Request

If this project is perceived as viable by the administration, our group will require adequate insurance provided by the school, space to build the wall on campus, approval for proper training through the outing club, and approval for this project as an IQP or other project. At this time we are not asking for any money as we intend to acquire the necessary funds through fundraising, corporate sponsorships, and Student Government Association through the outing club.

Suggestions for adequate rooms would include: one of the rarely used squash courts, the storage room on the second floor of Alumni Gym, or any other location of similar size and height (12'+) which can be locked.

The CAVE, being a student project, would be designed, built and (if possible) run by students. This project would not require extensive labor on the part of the WPI staff, and it would be an excellent addition to the community. We are highly enthusiastic about the CAVE and will submit a more formal request detailing design specifications, liability issues, and all other details of the wall, if this proposal is approved.

Appendix E – IQP Blog

Bouldering Wall IQP

THURSDAY, APRIL 1, 2010

Maybe the best news so far!

We have some news which basically assures that our bouldering wall is going to be built and is going to be great! We had a meeting with some of the Student Government people, and they essentially promised us a fair amount of money for our project. They also suggested we go to President Berkey for additional funds so we'd be able to fill the Squash court. A few days later, we met with him and he offered to match what SGA is offering! We're pretty much set now, we just have to do the final tasks leading up to construction: Buying the holds, acquiring keys for the room, writing our IQP paper and so on.

Our wall will be up over the summer and should be fully operational by A-term 2010

Posted by morgan at 11:01 AM 0 comments

TUESDAY, MARCH 16, 2010

Location!

Hello, we have received some pretty excellent news recently - We have permission to use one of the Squash courts in the gym for the location of our bouldering wall! A few weeks ago, we sent an email to many staff members asking how we could get permission to use the room we'd been fighting for, a storage room on the third floor of Olin. As you know, getting permission for this room has been a difficult battle because nobody seems to have the authority to give us the go-ahead. Anyway, instead of giving us permission for that, we got approval for a totally different, much larger and more accessible room. We are all quite excited about this!

Also, D-Term has just started, so we're figuring out meeting times and the like.

Posted by morgan at 6:51 AM 0 comments

TUESDAY, FEBRUARY 23, 2010

Room Tour

Last week, our meeting took the form of a tour around the room we want to build our wall in. We had an employee of RockWerx with us, and we showed him the room so he could have a better idea of the engineering required and to give us more information about how they'd do things. He was excited about the project and didn't foresee any real

problems as far as construction would go.

The meeting helped assure us that the room made sense as a place to put our wall and that RockWerx was a good company to trust with building it.

As the term goes on, getting permission to use the room continues to be our last major hurdle.

Posted by morgan at **1:35 PM 0 comments**

TUESDAY, FEBRUARY 9, 2010

Tech Wall - Building Holds

When we first started this project, we had the idea of building our own holds to reduce costs and so we could easily acquire transparent ones. As the project got further along, the Tech Wall became a secondary project - plus the Adopt-A-Hold project was an excellent fund-raising tool. Now that we've got some more time on our hands, we're once again thinking about the construction of the Tech Wall.

Building climbing holds is not trivial, of course, but it seems like something we could do at least in small quantities. We've done some research and some begging, and hold companies don't want to give us transparent holds (at least not for cheap!) Our first step for this will be, of course, acquiring the materials. There are a few different ways to make them, we'll probably use a resin/sand combination which is popular among hobbyists.

The project will probably go something like this:

1. Make a mold out of clay using a real climbing hold.
2. Make the resin/sand mixture.
3. Pour that into the mold.
4. Wait for it to harden.
5. Realize we screwed up step 2, do steps 2-4 again.
6. We have a hold! Now we experiment with making our own hold shapes/designs and figuring out how to make it more transparent (this sand thing could make it difficult)

Posted by morgan at **12:30 PM 0 comments**

TUESDAY, FEBRUARY 2, 2010

Update and Media

C Term has begun and we've been setting goals, meeting with people and making progress. We've taken some pictures of the Adopt-a-Hold fund raiser we did last term, and we took a picture of the team for press purposes. Speaking of which, there was an article written about us and our project in the Towers. We hope that having publicity and awareness about our project on campus will make people more excited and determined to help see our project through!

One of our two posters for the fund raiser:



A hold engraved by Sanado with the WPI seal and type:



The team:



Posted by morgan at 12:13 PM 0 comments

MONDAY, DECEMBER 7, 2009

B-term winding down

Hello again. As we near the end of B-term, we've started looking hard at how to get the funds we need to build this wall. The hope of having the wall up by the end of C-term has slipped away, but it seems likely that we can have it built over the summer. We've made some progress getting approval, though it seems like every person we talk to tells us to talk to someone else as well.

Lately, the group has been working on and commenting on a few different documents: An article about us in the school paper, a letter to Alumni requesting funding, and a letter to various companies requesting support. We wanted to give every group member a chance to give input on these documents, so we've decided to use Google Wave to write/edit them. So far, it's proved to be significantly more useful than email for this sort of thing.

That's about it for now, look for our article soon in The Towers.

Posted by morgan at **11:33 AM** **0 comments**

MONDAY, NOVEMBER 23, 2009

Status update

Hello all. There have been some interesting developments lately.

Contracts/Liability/Money

WPI does not want us to build the wall ourselves; they instead want us to give plans to the official WPI contractor who will build it with his team. We've talked to the contractor, and it does not seem realistic that he could build it within our budget constraints. In light of this, we've contacted RockWerx, the construction company that built Central Rock and MetroRock. Their prices are significantly more reasonable, and the hope is that we could have them do the construction.

Tech Wall

We never quite had the heart to give up on our high-tech bouldering wall idea. Instead of trying to integrate electronics into the wall we're building on campus, we've decided to build a prototype for the tech wall elsewhere. Because it's unlikely that we will be doing the construction work for the on-campus wall ourselves, we will have time to create this prototype high-tech wall.

We would like to prove that our concept is scalable, so our current design is to build two independent modules. Each module will be a 4x10 wall, with a light and sensor in every grid space. The electronics will be modular as well, so that more wall-pieces could be added on with minimal extra effort. Our proof of concept will be an 8x10 wall with adjustable angle for each of the two 4x10 wall-pieces.

We have some sketches and more design ideas, they will be up soon.

Posted by morgan at **10:40 AM** **0 comments**

MONDAY, NOVEMBER 2, 2009

Moving forward...

Hi everyone.

This is the beginning of a hopefully constant stream of updates on our project, now that our IQP has officially begun.

Meet the Team

Our current team looks something like this:

Thomas Liu (CS/IMGD, 2011)

Felipe Polido (RBE, 2011)

Morgan Quirk (CS/IMGD, 2011)

Richard LaMura (Aero, 2011)

Evert Fairman (ECE, 2010)

Daniel Nuzzo-Mueller (PH, 2011)

Sanado Barolli (ME, 2011)

Karl Gibson (CS/IMGD, 2011) was a part of our project and has made significant contributions but has decided to go to Denmark instead of being an official part of our project. Thanks Karl!

Finding a Room

Last year we went about the task of finding a place on campus to put this. Space on campus is surprisingly limited and in the end we were looking at two locations: the third floor or Olin Hall and the bike room in East Hall. Some final communication at the beginning of this school year more or less solidified our location to be in Olin Hall. At this point we're waiting for funding and final approval from the Physics department head.

Funding

We managed to raise some pretty hefty funds towards climbing holds for the wall with our Adopt-A-Hold program. I think we had quite a presence on campus so word has spread about our project and we're even getting interviewed by the towers tonight at our weekly meeting.

Obviously funding is a big issue with this project. There's certain liability when it comes to students building things (especially things that will be climbed on) on campus, so we've been looking into getting a contractor to build the wall for us. We've gotten a quote of around \$17,000, which is a little higher than we'd expected.

It's looking like we may be able to get support from the SGA so this project is becoming more of a reality by the day.

We're currently reaching out to outside companies for support, and we'll update as more information comes in.

Moving Forward

We're getting ready for all of the engraving that we need to do as part of the Adopt-A-Hold program and working to secure funding.

A 3-d model of the room and a proposed look for the completed wall is in the works and we're doing some more investigation into the tech wall idea.

Look forward to more posts!

-Thomas

If you're looking to contact us, send an email to *iqp at wpi dot edu*. Yes. It's the best iqp mailing list ever.

Posted by thomas at **10:55 AM 0 comments**

TUESDAY, JULY 21, 2009

Design and Information Document

Here's a document we wrote that talks about the specifics and acts as a project pitch. We presented this document to some members of the WPI community, including President Berkey.

Document

Posted by morgan at **6:07 PM 0 comments**

MONDAY, JUNE 8, 2009

Technical - Computer Science

This blog will be a way to document our project and gain some interest from the community. I'll start out by describing some ideas about how we're going to approach the computer science side of the project.

Our current rough plan is as follows:

- 1.** Write some low-level serial-port interface code in C to talk to the electronics. We don't know exactly what will be required here yet, but probably some functions for scanning the sensors and maintaining the lights will be necessary. Ideally there will not be much C code.
- 2.** Write the necessary wrappers to be able to import these functions from Python. I've done some research and found that this is not too difficult.
- 3.** Do the rest of it in Python, using wx for GUI components. There's going to be a lot of code in this segment.
- 4.** We entertained ideas of making web applications for some of the functionality we want to support. We'll see.

There will be (at least) two main functions of the software. Primarily, it should provide a

simple interface for climbers to find and select a route. Once it is selected, the system will control the lights and any tracking/games/competition routines that apply. Additionally, the software will provide functionality to allow administrators to set new routes, modify settings, etc.

Posted by morgan at **4:51 PM** **0 comments**

Blog up and running

This is a post to introduce our climbing wall project and to test the layout etc.

Posted by morgan at **4:30 PM** **0 comments**

Appendix F – Cave Climbing Manual

C.A.V.E. Bouldering Wall at Worcester Polytechnic Institute Operating Manual

WPI Outing Club

East Hall

[Address Information]

WPIOC oc@wpi.edu

<http://oc.wpi.edu>

Manual Outline

- I. Overview
 - 1. Project Description
 - 2. Goals and Objectives
- II. Operation Guidelines
 - 1. Hours of Operation
 - 2. Rules
 - 3. Instruction
 - 4. Maintenance
- III. Staff
 - 1. Schedule
 - 2. Responsibilities
 - 3. Office Procedures
 - 4. Staff Qualifications
- IV. Safety Program
 - 1. Equipment Inspection
 - 2. Spotting Class
- V. References

I. Overview

1. Project Description

The C.A.V.E bouldering wall is an on-campus IQP currently in development by a group of WPI students. The original proposal^[1] was for a bouldering wall which was augmented by having lights and sensors on each climbing hold. When the budget became more of a concern, the project was reduced in scope to include just the construction of an on-campus bouldering wall. The wall will likely be constructed in the bike room of the new East Hall dormitory building. This section will be updated as the project develops.

2. Goals and Objectives

The primary goal of the C.A.V.E. project is to provide the WPI community with a convenient on-campus bouldering wall for fitness and social purposes. Basic instruction in climbing and safety procedures will also be provided by staff members.

II. Operating Guidelines

1. Hours of Operation

The bouldering wall will be open three days a week, Thursday, Friday, and Saturday from 6pm until midnight. Additional hours may be added by staff members as they wish.

2. Rules

All participants, observers, and staff must abide by the rules. The rules will be prominently displayed near the wall at all times. Individuals violating the rules will be warned appropriately. The staff reserves the exclusive right to expel any individuals failing to abide by the rules. The rules for the wall are as follows:

1. Climbers must check in with the on-duty staff member before climbing.
2. Climbers must pass a spotting proficiency class and complete a Participant Agreement, Release, and Acknowledgement of Risk
3. Any minor must have the Participant Agreement signed by a parent or guardian.
4. Parents are responsible for the actions of their children.

5. Absolutely no drugs or alcohol are allowed at the climbing wall.

6. Please remove all jewelry, watches, keys, etc. These objects can cause injury to you and/or your spotter(s). These objects are also bad for the crash pads.

7. Never climb alone! You must always have a spotter, and there must always be a staff member present in the room.

8. Pay attention! If you are spotting a climber, your responsibility is to guide the person in the event of a fall. Not being attentive to the climber's every action/movement can result in injury to you, the climber, or others.

9. Only climbers on routes, spotters guarding climbers on route, and staff members may be in the climbing area.

10. The Climbing Wall is not responsible for lost or stolen articles.

3. Instruction

The staff will provide a brief (20 minute) class to new climbers to teach them the basics of spotting. This class will be given to groups of climbers or individually, depending on the activity at the wall. An outline of the class is given in the "Staff" section of this manual.

4. Maintenance

The wall will be routinely inspected before opening by staff members for any potential hazards. If there is reason to believe the conditions of the wall are unsafe, the wall will not be opened until the issue is resolved.

III. Staff

The wall must be staffed at all times when open. The staff member(s) may spot climbers if there are no spotters available. The staff members have the right to disallow anyone from using the wall if safety becomes a concern or if the rules are not being followed.

1. Schedule

The staffing schedule will be posted on the WPI Outing Club website, as well as physically outside the wall. Staff members are encouraged to use the website and make printouts of the schedules to post outside the wall.

2. Responsibility

The primary goal of the staff members is to ensure the safety of the climbers. The two main ways of ensuring safety are through instruction and spotting.

3. Office Procedures

The staff members must file the Participant Agreement, Release, and Acknowledgement of Risk forms in the Outing Club filing cabinet. The staff members must check all climbers to ensure they have signed all necessary documentation and agreements.

4. Qualifications

Staff members must have the following qualifications:

1. Current CPR/First-Aid certification (from Red Cross, AHA, or similar organization)
2. Satisfactory completion of the spotting instruction class.

IV. Safety Program

1. Equipment Inspection

Before the wall opens, the staff member(s) on duty must inspect the wall to ensure that it is safe to climb on. This includes positioning the crash pads and ensuring there is no damage to the wall itself.

2. Spotting Class^[2]

Overview: The spotting class will last approximately 20 minutes.

1. Introduction to the facility and explanation of bouldering

a. Instructor shows around the wall, pointing out vertical and overhanging sections.

2. Explanation of purpose and style of bouldering:

Short climbs, no ropes: Every fall is a ground fall

3. Safety features of the gym

a. Instructor points out mats. Explains that they should be clear of all items (e.g. food, drink, gear, shoes, people) that could potentially cause a falling climber to injure his or her ankle or back.

b. Spotting

Instructor talks about what spotting is, why it is used, when it should be used and how it should be performed.

This is approximately what the instructor has to say:

1. About spotting in general: Spotting is a crucial part of climbing extreme bouldering routes. The goal of a spotter is not to catch a bouldering climber when they fall, but to break their fall to prevent a serious head injury and steer them into a safe landing. Assume a solid stance on the ground, with legs slightly bent, and arms outstretched towards the climber and slightly bent, ready to break a fall. If the situation could result in a potentially dangerous fall, get two or even three spotters to break the climber's fall. This is more of a concern in outdoors scenarios with taller boulders.

2. About spotting priorities:

- i. Your highest priority is to protect the boulderer's head and spine.
- ii. The next priority is to steer the boulderer toward a good landing.
- iii. Last, if possible, reduce the force of the boulderer's fall.

To spot well, know the problem and anticipate the moves. Focus on the boulderer's center of gravity. With most men this is a few inches above the belt line. With most women, it is at the belt line.

Don't make the mistake of watching hands, arms, feet, or legs. These tend to fly about giving the appearance that the climber is falling, even though he or she may still be hanging on.

3. About spotting technique for vertical walls:

A climber will usually fall feet first from a vertical wall. Grab the boulderer by the hips and steer him to a good landing. Absorb some of the fall with your arms and legs. The boulderer absorbs the rest of the impact with his or her legs. [Instructor demonstrates position].

4. About spotting technique for overhanging walls:

When falling off overhangs the body often falls at an angle to the ground, instead of feet first. In these hazardous cases grab further up the body (above the center of gravity), along the upper lats or underarm. This will cause the body to rotate feet downward. Steer the climber to a good landing and absorb the impact as above. [Instructor demonstrates the technique with a partner].

5. About common sense and judgment of situation:

Sometimes the best a spotter can do is push the falling climber away from danger and into a safer landing position. This is more of a concern for outdoors bouldering. However, even in the gym, one should always make sure that the safety rules are being followed, and no danger is created. Over-zealous spotting is preferred to no spotting, but you should not support the climber while he or she is still on the problem - your job as a spotter is to break the climber's fall when he or she is falling.

4. Instructor repeats safety rules:

- a. Keep mats clean and clear of all items
- b. Keep clear of area if not spotting (i.e. don't walk underneath a climber)
- c. Use caution when climbing and don't climb in each other's way
- d. As a climber, be aware of your body position so you can land safely on your feet
- e. Use a spot if you need it
- f. Use common sense and good judgment and be aware of your surroundings

5. Practice spotting

All practice happens one at a time, with instructor(s) watching.

Scenario 1: Feet-first fall from a vertical wall

Scenario 2: Fall from an overhang

Scenario 3: Fall from a weird position overhanging (climber remembers to be aware of his or her position and try to land safely, spot remembers to steer to safe landing)

Scenario 4: Two spotters working together (making sure they know each other's responsibilities)

V. References

- 1: WPI Bouldering Wall Proposal
- 2: Taken from the MIT Climbing Wall Operating Manual