

# **Reactive Power Compensation and Energy Storage in Wind Power Plant**



**Xu Chen, WPI**

**Vorayos Rongrojkamranan, WPI**

**Jie Ying, HUST**

**Xin Zhou, HUST**

# Reactive Power Compensation and Energy Storage in Wind Power Plant

An Major Qualifying Project Report  
submitted to the faculty of  
Worcester Polytechnic Institute  
in partial fulfillment of requirements for the  
Degree of Bachelor of Science  
Submitted by:

---

Xu Chen

---

Vorayos Roungröjkamranran  
Submitted on Friday, January 6, 2012

Submitted to:

---

Professor Kevin Rong, Major Advisor

---

Professor Xinming Huang, Co-Advisor

## **Abstract**

The limited resources of fossil fuels and recent environmental concerns, wind energy emerges as a clean renewable energy to substitute the traditional energy sources. However, wind energy has several shortages due to its energy harnessed from the wind. Research shows that these shortages can be improved by implementing reactive power compensation and energy storage technology into the wind power plant. This project focused on implementing the two technologies into large wind farms and combining them into one system to maintain stability control of the wind power plant.

## **Acknowledgements**

We would like to thank our advisors Professor Kevin Rong, Professor Lingsong He, and Professor Yuan Xiaoming for their unconditional support and guidance, as well as encouragement, throughout this project. We would also like to thank the faculty of HuaZhong University of Science and Technology Electrical Engineering department who donated their time and expertise: Dr. Jiabing Hu and Dr. Jiakun Fang.

## Authorship

This report is the product of the collaborative effort of four students. Each section was primarily written by one student, and the entire report was edited by all team members. The paper was formatted by Xu Chen.

<b>Section</b>	<b>Author</b>
Title Page	X. Chen
Abstract	V. Roungrojkamranan
Acknowledgements	X. Chen
Authorship	X. Chen
Table of Contents, Table of Figures, Table of Tables	X. Chen
1 Introduction	All
2 Background Information	All
2.1 Wind Power	X. Chen
2.2 Wind Energy-generating system	X. Chen
2.3 Reactive power Compensation	All
2.4 Energy storage	V. Roungrojkamranan
3 Research Methodology	All
4 Results and Analysis	All
5 Conclusions	X. Chen
References	X. Chen
Appendix A	X. Chen
Appendix B	V. Roungrojkamranan

## Table of Contents

Acknowledgements.....	1
Authorship.....	5
Table of Figures .....	7
Table of Tables .....	7
1. Introduction.....	8
2. Background Information.....	9
2.1 Wind Power.....	9
2.2 Wind Energy-generating System .....	10
2.2.1 Wind Turbine.....	10
2.2.2 Double Fed Induction Generator (DFIG) Wind Trubine.....	12
2.2.3 Fault ride-through capacibility .....	14
2.3 Reactive Power Compensation.....	15
2.3.1 Reason to conduct reactive power compensation.....	15
2.3.2 Methods of dynamic reactive power compensation .....	17
2.4 Energy Storage .....	18
2.4.1 Application for energy storage .....	18
2.4.2 Energy Storage Technology .....	19
3. Research Methodology .....	21
3.1 Archival Research .....	21
3.2 Software Simulation.....	21
4. Result.....	22
4.1 Wind power plant circuit analysis.....	22
4.1.1 Reactive power compensation device circuit .....	23
4.1.2 Energy Storage circuit analysis .....	23
4.2 Simulation Result.....	25
4.2.1 Voltage and reactive power regulation in wind power plant.....	25
4.2.2 Smoothing Power fluctuation in wind power plant .....	28
4.2.4 External impacts on the wind power plant .....	30
Conclusion .....	33
Reference .....	35
Appendix A: Wind power plant parameters .....	36
Appendix B: Simulation code.....	37

## Table of Figures

Figure 1 Worldwide usage of wind power (WWEA, 2010) .....	10
Figure 2 Wind turbine model .....	11
Figure 3 Wind turbine power generating versus wind speed .....	12
Figure 4 DFIG wind turbine model (Anaya-Lara et al, 2009).....	13
Figure 5 Fault ride-through chart .....	14
Figure 6 Wind farm station with reactive power compensation (STATCOM) .....	18
Figure 7 Wind power plant with energy storage system and reactive power compensation.....	23
Figure 8 Energy Storage system circuit schematic.....	24
Figure 9 Wind power plant without energy storage and reactive power compensation device .....	25
Figure 10 Power generated of the original system.....	26
Figure 11 Voltage regulation by reactive power compensation device .....	27
Figure 12 Power generated with stabilize voltage in the wind power plant .....	27
Figure 13 Power generated (left) versus Wind speed (right) .....	28
Figure 14 Battery (Top) charge/discharge characterisitc base on the different between the power generated(bottom, blue) and load(buttom, red) .....	29
Figure 15 Output power with energy storage system added .....	30
Figure 16 Fault circuit at 15 second .....	31
Figure 17 Power generated.....	32
Figure 18 Faults circuit (subsystem) .....	32
Figure 19 Eight faults in the wind power plant.....	33

## Table of Tables

Table 1 Voltage and reactive power changes due to active power (A 300MW wind farm in coastal Jiangsu .....	16
Table 2 Battery energy storage value analysis.....	20

## 1. Introduction

Wind is a free and unlimited source of energy that has attracts many people for its energy security and environmental benefit. With increasing construction of large wind power plant around the globe, maintaining control stability becomes important aspect of the wind power plant. This project will discuss the technical problems many wind power plant needs to solve in order to operate in a stable state.

One of the major technical challenges for wind power plant is power fluctuation at the output. The power fluctuation is caused by the variations of the wind speed inducing the generator to produces different power levels at varied time. In the past, the power generated from the generator were transmitted directly to the grid without any kind of energy storage. Regardless of power demands during the peak and off-peak hours. In a large wind power plant, power fluctuation can leads to voltage variation at the interconnection point of the grid. The use of energy storage devices can smooth the power fluctuation; subsequently, it will improve power distribution of the wind power plant and maintaining stability control of the wind power plant when subjected to any voltage flicker.

Another major technical concern is the reactive power regulation in large wind farm. The amount of the reactive power produced or absorbed by the wind farm and the grid changes because of the power changes at different wind speed. Meanwhile, the size and number of wind farms contributing to the energy production is growing, the reactive power produced in large scale wind farm cannot be ignored. As the wind power scale continue expand, all the influence of wind power on energy quality shouldered by power grid is not economic and even unaffordable. Therefore, it is totally necessary to make appropriate reactive power compensation within wind farm to be constructed.



This project introduces an integrated energy storage and reactive power compensation in a large wind power plant. The energy storage serves as auxiliary sources of energy for the wind farm during dynamic changes result in power fluctuations. Reactive power compensation can increase the reactive power regulating capacity which can provides voltage stability in the wind farm. A control strategy is developed in this project to manage system stability in wind power plant.

## 2. Background Information

This section will investigate the potential market for wind power plant, existing wind turbine technology, existing energy storage and reactive power compensation technology, and the importance of wind power plant capabilities needed to operate in stable state.

### 2.1 Wind Power

With increasing energy demands, wind energy becomes a very popular option due to the recent change in the public opinion towards protecting the environment. And it is also viewed as a safe energy source that does not rely on any limited resources. Figure 1 shows the worldwide usage of wind power.

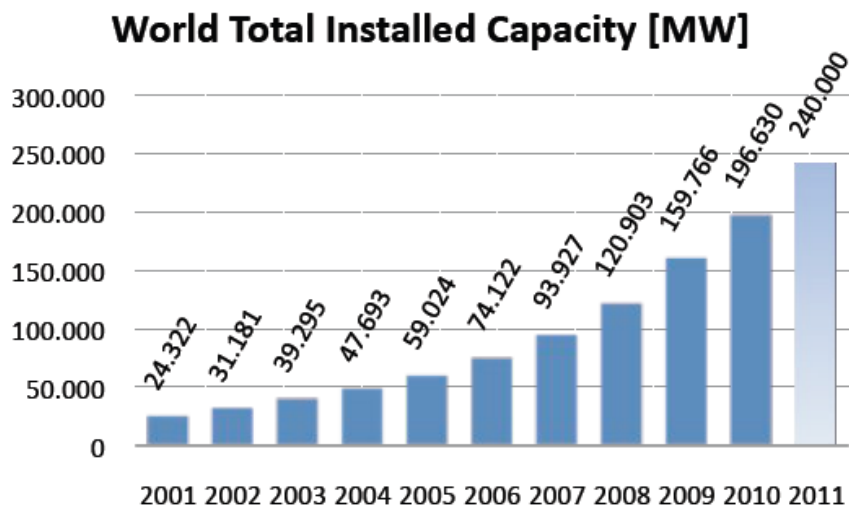

## **Figure 1 Worldwide usage of wind power (WWEA, 2010)**

In 2010 worldwide capacity of wind power has reached to 196 MW that has showed a growth of 23.6% since 2004 (WWEA, 2010). The increasing use of wind power is very prevalent in the United States. In 2009, 1.8% of the total energy produced was from wind power. In future plan, the U.S. Department of Energy have outlined a plan to increases the U.S. wind power to contribute 20% of total energy by the year 2030 (U.S. Department of Energy, 2009).

### **2.2 Wind Energy-generating System**

Wind power is harnessed when wind forces the turbine blades to rotate. The spinning of the blades rotates the rotor of the motor, which generates electricity through the wind turbine generator. This motion is then converted into electrical power delivered to the grid. In recent decades, wind energy technology has rapidly evolving with the increasing demands for wind power plant stability. This section will discuss the stability of the variable speed Double fed induction generator (DFIG) wind turbine in wind power plant.

#### **2.2.1 Wind Turbine**

Wind turbine produces electricity by using the power of the wind to drive an electrical generator. Wind passes over the blades to exerting a turning forces to turns the shaft inside the wind turbine, which goes into a gearbox. The gearbox increases the rotational speed to induces an magnetic field in the generators, and then converted into electrical energy (Anaya-Lara et al, 2009).

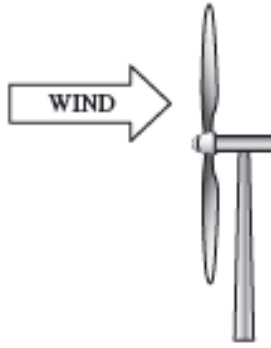

**Figure 2 Wind turbine model**

The power of air flow to the wind turbine is given by the following equation{ (Burton et al, 2001), (Manwell et al, 2002)}:

$$P_{air} = \frac{1}{2} \rho A v^3$$

where

$$\rho = \text{air density, } 1.225 \frac{\text{kg}}{\text{m}^3}$$

$$A = \text{swept area of rotor in, } \text{m}^2$$

$$v = \text{wind speed, } \frac{\text{m}}{\text{s}}$$

The equation above gives the power available in the wind the power transferred to the wind turbine rotor is reduced by the power coefficient, C:

$$C = \frac{P_{\text{wind turbine}}}{P_{air}} \text{ then,}$$

$$P_{\text{wind turbine}} = \frac{1}{2} C \rho A v^3$$

From the equation, we can see that the power output of the wind turbine is varied with wind speed. Figure 3 describes the wind turbine power characteristic with wind speed.

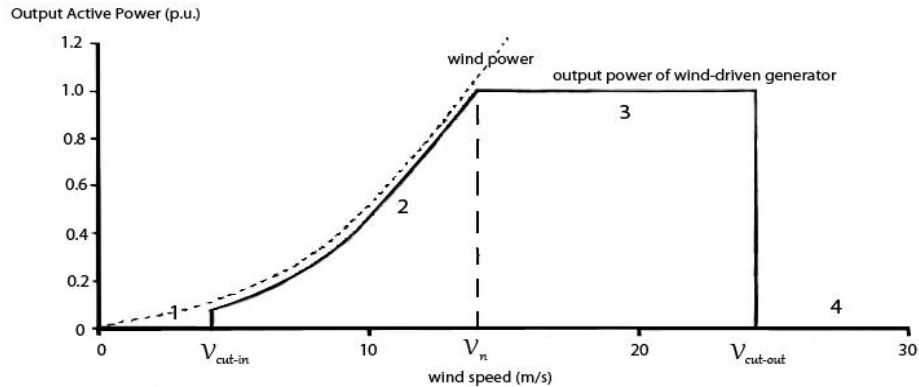

**Figure 3 Wind turbine power generating versus wind speed**

The graph gave three key factors on the characteristic of wind turbine power output:

Cut-in wind speed: the minimum wind speed at which the machine will deliver power.

1. Rated wind speed: the wind speed at which rated power of wind turbine is obtained.

The rated power is the maximum power output of the wind turbine generator.

2. Cut-out wind speed: The maximum wind speed at which the turbine is allowed to deliver power or the limited wind speed a wind turbine can operate

These characteristics described above are varied depending on the type of wind turbine and it also depends on the manufacturers.

### **2.2.2 Double Fed Induction Generator (DFIG) Wind Turbine**

The DFIG wind turbine is a wound-rotor induction generator that operates by controlling slip rings or by the power converter interconnected with the grid. See Figure 4 for the DFIG wind turbine schematic. The stator is directly connected to the grid and the rotor is interfaced through a crowbar and a power converter. The voltage on the stator is applied from the grid and the voltage on the rotor is induced by the power converter.

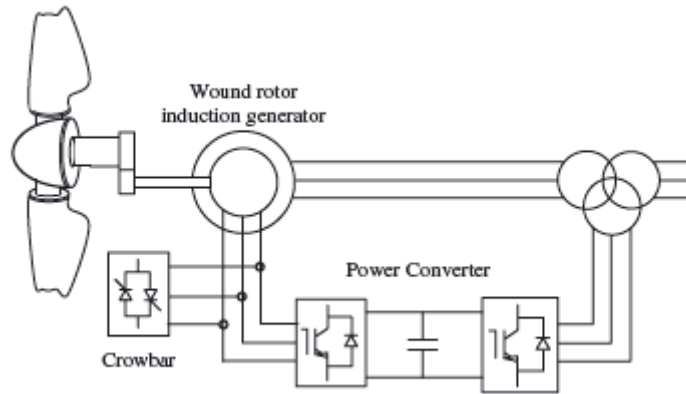

**Figure 4 DFIG wind turbine model (Anaya-Lara et al, 2009).**

DFIG wind turbine deliver power through the stator and rotor of the generator, while the rotor can also absorb power depends on the rotational speed of the generator. If the generator operates above synchronous speed, the power are delivered from the rotor through the power converter to the grid. If the generator is operates below synchronous speed, then the rotor will absorb power from the grid through the power converter. The power converter are consists of a Rotor-side converter (RSC) and a Grid-side converter (GSC).

The power converter controls the active and reactive power flow, and the DC voltage of the DC-link capacitor between the DFIG wind turbine and the grid by feeding the pulse width modules (PWM) to the converters (Seyedi, 2009). In addition an crowbar is implemented to prevent short circuit in the wind energy system that result in high current and high voltage.

The RSC converter operates at the slip frequency that depends on the rotor speed, and controls the flux of the DFIG wind turbine. The power rating of the RSC is determined according to the maximum active and reactive power control capability. The RSC can be simplified as a current-controlled voltage sources converter. The GSC operates at a network frequency and controls the voltage and current level in the DC-link circuit. It is used to regulate the voltage of

the DC-link capacitor (Akhmatov, 2003). Hence, DFIG wind turbine have the capability for generating or absorbing reactive power and control the reactive power or voltage at the grid side.

### 2.2.3 Fault ride-through capability

One of the important requirements for wind power plant is provide fault ride-through capabilities. This means that the wind power plant must withstand voltage dips to certain percentage of the nominal voltage and for a specific duration. In other word wind farm must not be disconnected from the grid during a fault or short circuit. This fault ride-through can be described in figure 5.

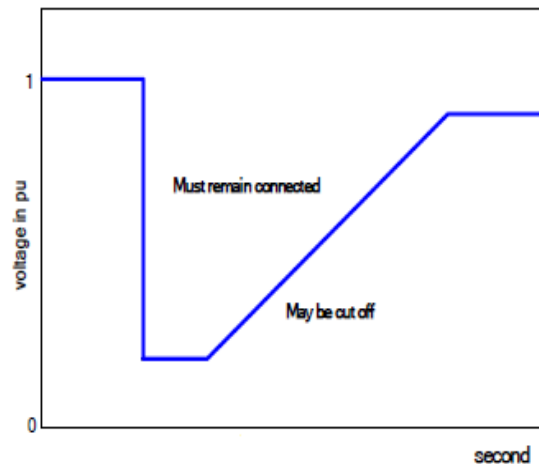

**Figure 5 Fault ride-through chart**

The graph is described by the voltage (in p.u) versus time characteristic and minimum requirement of the wind power plant. At the voltage dip wind farm and the grid must remain connected until it is returned to prefault values. In the transition of the voltage dip to prefault values, the wind farm and the grid has a chance that it may be cut off. Wind power plant must provide fast transition time to bring the voltage to prefault value.

One of DFIG capability during a fault ride-through situation is to control the generator output active power and reactive power. In a fault ride-through situation, there is a risk in the RSC because it can only handle certain amount of current flow through the converter. In Addition, there is also a risk of over voltage on the DC-link capacitor during this situation. When the RSC current or DC-link voltage hit their limits, the over current or over voltage protection is activated, respectively. This protection is controlled by the DFIG crowbar. The crowbar deactivates the RSC, and this leads to the DFIG rotor to be disconnected from the network. When the fault is cleared crowbar will reconnect the RSC, and the DFIG rotor will be reconnected to the network. It has the ability to restore itself to the prefault state.

### **2.3 Reactive Power Compensation**

The voltage on a transmission network is determined by the reactive power flows. DFIG wind turbines have the capability of controlling reactive power flow through the connection network and supporting the voltage network which they are connected. However, in a large wind farm controlling individual DFIG wind turbine to regulate reactive power flow is not feasible. It may not be able to control the voltage in the grid. On many occasion, the reactive power and voltage control at the grid is achieved by using reactive power compensation.

#### **2.3.1 Reason to conduct reactive power compensation**

As we can see from the Table 1(a 300MW wind power station in coastal Jiangsu), when the active power of the wind power station ranges 0%~100%, voltage of PCC point (common connecting points) ranges 224.924 ~ 226.027kV, reactive power exchange ranges -2.837~ 16.430 Mvar. Because the change of active and reactive output of wind power station is quite random at varied wind speed, if no appropriate reactive regulation is adopted, the voltage change of PCC will be frequently. Especially, after large-scale wind power station has been connected into the

power grid, it will not only affect the power quality of the power grid but also endanger the safe and stable operation of the power grid.

I side bus	J side bus	I side voltage	Active power on I side	Reactive power on I side	Power factor on I side
PCC point	Wind power station	225.135	-298.942	2.837	1.000
PCC point	Wind power station	225.483	-269.145	-3.808	1.000
PCC point	Wind power station	225.743	-239.325	-9.000	0.999
PCC point	Wind power station	225.918	-209.483	-12.800	0.998
PCC point	Wind power station	226.012	-179.619	-15.270	0.996
PCC point	Wind power station	226.027	-149.734	-16.430	0.994
PCC point	Wind power station	225.964	-119.829	-16.310	0.991
PCC point	Wind power station	225.823	-89.903	-14.900	0.987
PCC point	Wind power station	225.604	-59.956	-12.210	0.980
PCC point	Wind power station	225.305	-29.989	-8.221	0.964
PCC point	Wind power station	224.924	0.000	-2.891	—

**Table 1 Voltage and reactive power changes due to active power (A 300MW wind farm in coastal Jiangsu)**

Since DFIG generator set has high cost performance ratio, it is especially suitable for variable speed constant frequency wind power generation system. With regard to wind power station which adopts DFIG set, it is an ideal scheme to use the reactive power regulating capability of the doubly -fed wind power generator set to realize automatic reactive power regulation. However, considering the condition of wind power station in actual operation, with regard to a wind power station with hundreds of units, the output varies from unit to unit. When the output changes continually, it is undoubtedly complicated and difficult to make strategy of reactive power output coordination. Besides, for some wind generator equipment manufacturer,



there are some technical problems in dynamic regulation of wind generator power factor. Therefore, it is relatively reasonable to conduct reactive power compensation in wind power station.

### **2.3.2 Methods of dynamic reactive power compensation**

Power electronics based FACTS devices such as SVC and STATCOM are useful for dynamic compensation of reactive power. The STATCOM performs the same function as the SVC. However at voltages lower than the normal voltage regulation range, the STATCOM can generate more reactive power than the SVC. This is due to the fact that the maximum capacitive power generated by a SVC is proportional to the square of the system voltage (constant susceptance) while the maximum capacitive power generated by a STATCOM decreases linearly with voltage (constant current). This ability to provide more capacitive reactive power during voltage collapse is one important advantage of the STATCOM over the SVC. In addition, the STATCOM will normally exhibit a faster response than the SVC because with the VSC, the STATCOM has no delay associated with the thyristor firing. Figure 2 shows a wind power plant with reactive power compensation by STATCOM.

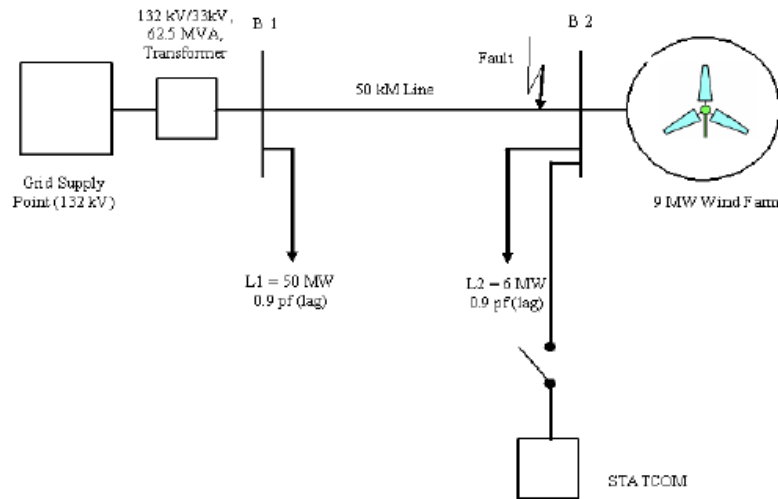

**Figure 6 Wind farm station with reactive power compensation (STATCOM)**

## 2.4 Energy Storage

This section will present energy storage system in wind power plant and how it can provide additional system stability. It will discuss the existing technology and the applications energy storage can be used in wind power plant.

### 2.4.1 Application for energy storage

It is important to examine the technical impacts energy storage device on the wind power plant. Because of the costs of the energy storage in large wind farm, it becomes impractical for its use if the energy storage does not solves any technical problem in the large network. This section will explore several energy storage applications can be used in the large wind farm.

#### 2.4.1.1 Transmission and Distribution

Transmission and Distribution system is a power transferring system that deploys the generated power from the wind farm to the grid then to the load. In the recent wind farm, all the power that is generated is directly transmitted to the load during the peak and off-peak hour. An energy storage device can be an auxiliary source of energy that can improves the transmission

and distribution of the power generated in the wind farm. Energy can be stored during the off-peak periods when the transmission and distribution system is on a weak load demands, and discharge during the peak period when load demands increases. The energy storage allows transmission and distribution system to deploy the generate power depending on the load demands.

#### ***2.4.1.2 Smoothing power fluctuation and maintaining voltage stability***

In DFIG wind turbine wind speed variation does not directly translated to the output power fluctuation. The power fluctuation of DFIG wind farm may not be significant, but it still exists. Power fluctuation in the wind power plant can leads to voltage instability. Depending on the strength of the grid connection, the resulted power fluctuations can result in grid voltage fluctuations, which would causes unwanted voltage flicker.

#### **2.4.2 Energy Storage Technology**

The energy produced by the wind farm can be stored in electromagnetically, electrochemically, kinetically, or as potential energy (Ribeiro et al, 2001). Each energy storage technology out there today usually includes a power conversion unit to convert energy from one to another. An Energy storage converter unit is installed to control the output power of the energy storage device. Power converter is most common energy storage converter device. Most of the modern power converters for this application type are built using a three phase bidirectional converters (Ribeiro et al, 2001). The power converter will act as an inverter to transmit power from DC to AC, and it acts as a rectifier to transmit power from AC to DC. The power converter can be controlled to operate at delivering or absorbing the power. In this project, battery energy storage will be used.

### 2.4.2.1 Battery

Battery is often used for long-term energy storage device. A battery energy storage system is made up of set of battery modules connected in parallel and series to achieve desired energy characteristics. Batteries are charged when they undergo an internal chemical reaction. They deliver the absorbed energy or discharge when they reverse the chemical reaction. The key factor of using batteries for high power energy storage applications is due to their high energy capability and life span. However it does not help much on smoothing the fluctuation of generated power of the wind turbine, therefore other energy devices are needed to work alone with battery (Senjyu et al, 2008). Table 2 is the value analysis for existing battery technology.

Category (weight)	Lead-Acid	NiCd	NaS	Lithium Ion	Vanadium Redox	Zinc Bromine	Metal Air
Life Cycle (8)	3	6	5.5	6	10	-	1
Capacity (6)	2	4	7	8	4	5	10
Efficiency (6)	6	6	8	10	7	6	2
Cost (9)	10	8	7	5	7	7	7
Self Discharge (7)	7	7	9	8	9	9	9
Safety (10)	4	4	9	9	9	4	8
Operating Temperature (5)	4	7	3	8	4	4	6
<b>Total</b>	<b>271</b>	<b>297</b>	<b>365</b>	<b>387</b>	<b>382</b>	<b>252</b>	<b>334</b>

**Table 2 Battery energy storage value analysis**

These battery technologies are weighted on seven different categories. In this value analysis Lithium Ion scores the highest, however, Vanadium Redox is only few points behind Lithium Ion. In consideration to pick each battery technology is better for this project. We considered the capacity of Lithium Ion and Vanadium Redox, and Lithium Ion scores the highest.

### **3. Research Methodology**

The purpose of this project is to reduce the influence of voltage variation in the grid that is caused by the power fluctuation in the output and uncontrollable reactive power flow in the grid. By implementing an energy storage system, we can smooth the power fluctuation which causes unstable voltage through the transmission line. And reactive power compensation to control the flow of reactive power through the wind farm power network.

To achieve the project goal, the main objectives were to:

1. Control reactive power flow in the wind power plant to stabilize the voltage in the interconnection point of the grid.
2. Smooth the power fluctuation in the wind power plant to increase output power stability and quality
3. Combine reactive power compensation device and energy storage into one system to increase wind power plant capability to maintain stability control.

#### **3.1 Archival Research**

We researched on the existing design system for energy storage system and reactive power compensation in large wind power plant. The design system for energy storage and reactive power compensation can vary based on the power network needs. From these literature works it would help us to gain a better understanding of their functionality and how they interact with the large power network in different situations. And acquire the applications that are needed to control the stability of our wind power plant.

#### **3.2 Software Simulation**

To achieve these objectives, we used MATLAB/ Simulink software to simulate our results. MATLAB/Simulink has a built-in DFIG wind turbine model. This model is based on GE

1.5 MW DFIG wind turbine. It takes in two inputs; wind speed and circuit breaker. The model is designed for groups of DFIG wind turbine and how they interact with large power system. It doesn't provide individual analysis of DFIG wind turbine performance. Any external inputs would be discarded. We designed a 450 MW wind farm and 250 km long transmission line with 220 kV sources and observed the power flow and voltage stability in this wind power plant.

#### **4. Result**

This section will investigate the simulation result of our design system and observe how our design system can stabilize an unregulated wind power plant. It will discuss the individual result of reactive power compensation and energy storage system in wind power plant. In addition, we will test the both system under external contribution to the wind power plant instability and how both energy storage and reactive power compensation interact with the wind power plant to maintain stability.

##### **4.1 Wind power plant circuit analysis**

In this project, we simulated a 450 MW wind farm (see Appendix A for wind farm parameters) connected to grid with a 250 km long transmission line and 220 kV sources, and the reactive power compensation and energy storage. Short circuit are added in between the transmission line that can be triggered in any simulation time. See figure 7 for full wind power plant design system. This simulation shows the wind power plant before and after energy storage and reactive power compensation are added. We want to observe the wind power plant's ability to control voltage variation and power fluctuation.

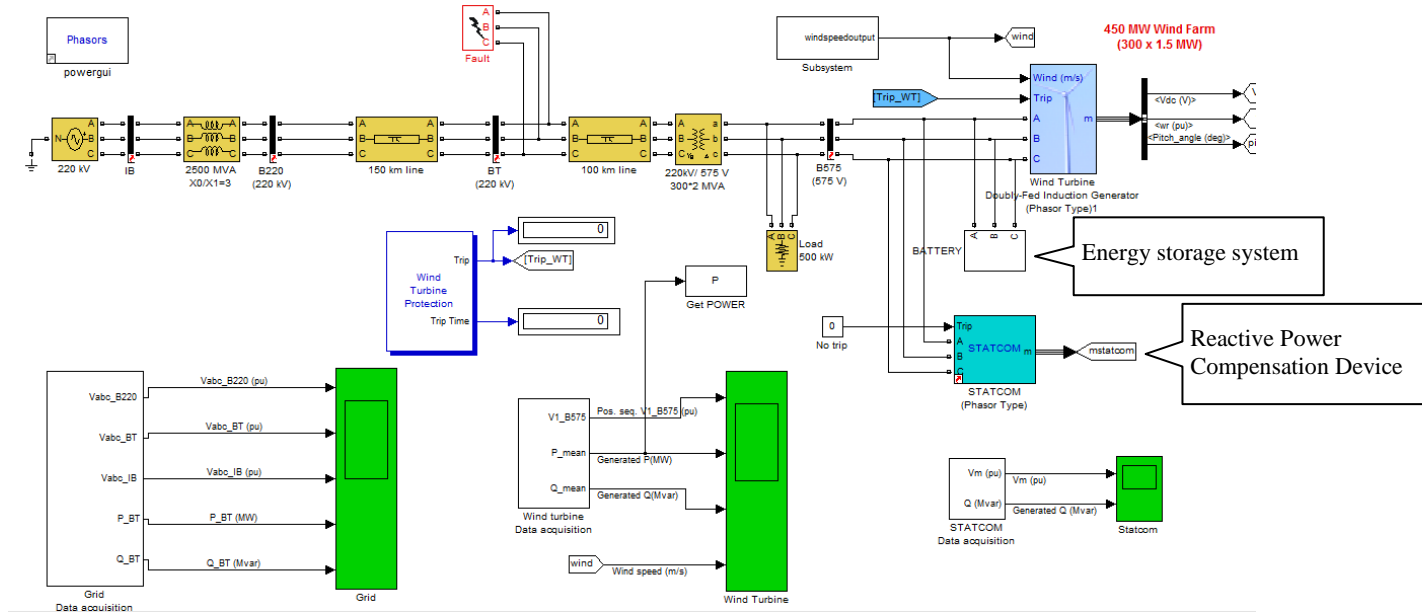

**Figure 7 Wind power plant with energy storage system and reactive power compensation**

#### 4.1.1 Reactive power compensation device circuit

MATLAB/Simulink has a built-in model of reactive power compensation device. See Appendix A for the reactive power compensation device parameters.

#### 4.1.2 Energy Storage circuit analysis

This energy storage system consists of 17 batteries in series and 100 in parallel. It has total voltage of 816V and capacity of 5000 Ah. The energy storage system cannot be simulated in the same workspace as the wind power plant. Another workspace is created to implement energy storage system in wind power plant. The energy storage system receives the simulation result from the wind power plant workspace and stored the result in a programmable source. See Figure 8 for energy storage system circuit diagram.

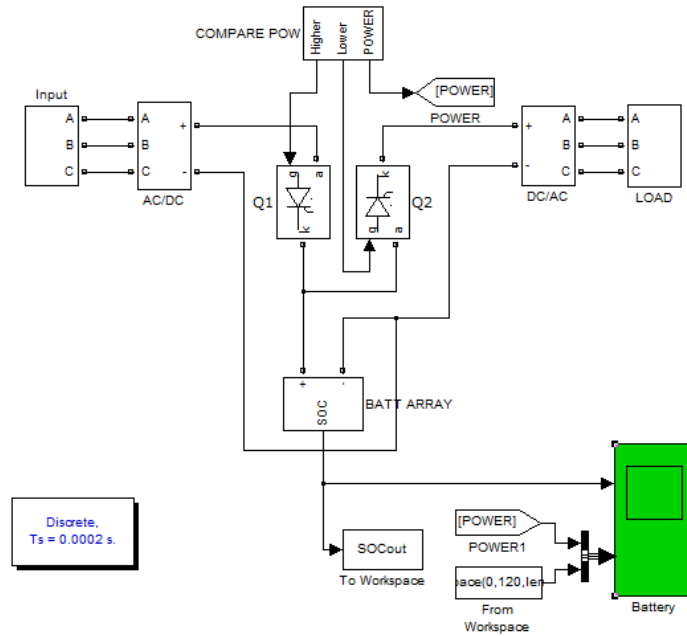

**Figure 8 Energy Storage system circuit schematic**

The programmable sources will feeds the result from wind farm through an AC to DC converter to charge the battery, and discharge the battery through a DC to AC converter. The charge and discharge state of the battery are controlled by the thyristors (Q1 and Q2). The thyristor will turns on and off based on the level of power produced from the wind farm. By setting a power reference control in the energy storage system, we can control the charge and discharge states of battery. In this project a random power reference will be generated. If the wind farm produces more than the power reference; charge thyristor (Q1) will turn on and storage the extra power into battery. If the power produced is less the power reference; discharge thyristor (Q2) will turn on and the battery will discharge the required amount of power equals to the reference power. The discharge results from the battery are collected in the load, and then feed into a programmable source on wind power plant. And examine how energy storage system impacts the system stability. See Appendix B for simulation code.



## 4.2 Simulation Result

This section will discuss the simulation result of the designed system implemented into the wind power plant.

### 4.2.1 Voltage and reactive power regulation in wind power plant

Reactive power flow in the wind power plant controls the voltage stability in the interconnection point on the grid. To keep voltage in the system at between 1.0 p.u wind power plant must operate in two modes. First mode, if the voltage is below 1.0 p.u wind power plant needs to inject reactive power. Second mode, if the voltage is above 1.0 p.u the wind power plant needs to adsorb reactive power. In this section, two simulation results would be compared to view the different between a wind power plant with and without reactive power compensation.

Figure 9 shows the simulation without reactive power compensation.

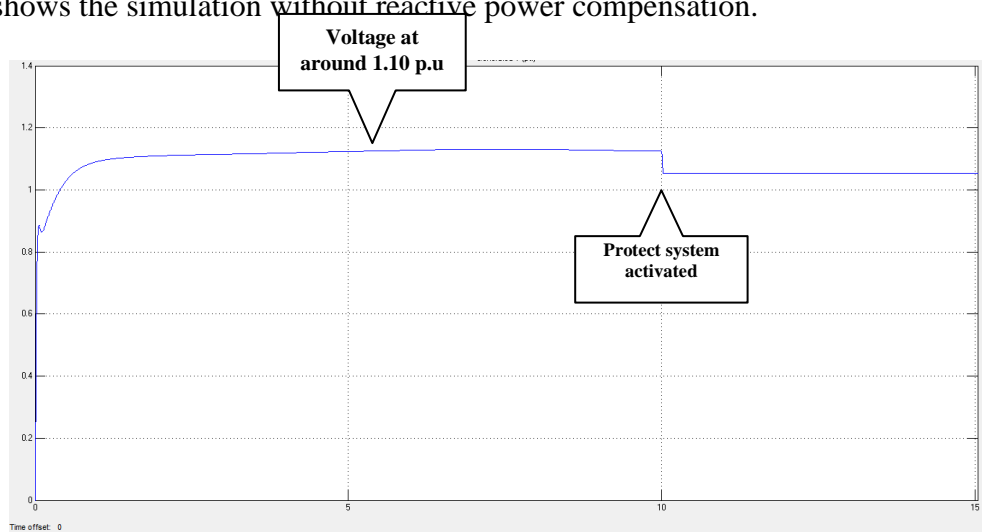

**Figure 9 Wind power plant without energy storage and reactive power compensation device**

The simulation result shows the voltage in the wind power plant is kept around 1.10 p.u. At 10 second of simulation time, a voltage dip happens within 0.02 second that brings the voltage to 1.0546 for the rest of simulation time. This voltage dip occurs because there is a wind

turbine protection system in the wind power plant. If the wind power plant realizes that the wind turbine output voltage is above 1.1 for 10 seconds an automated protection system is activated, in this case, the wind farm are disconnected from the grid. Because high voltage means that there is significant amount reactive power flow in the wind power plant that can cause damage to the wind turbine generator over time. This simulation shows that a large wind power plant has a harder control of the reactive power. As result, figure 10 shows the simulation result of how voltage instability affect the power generated.

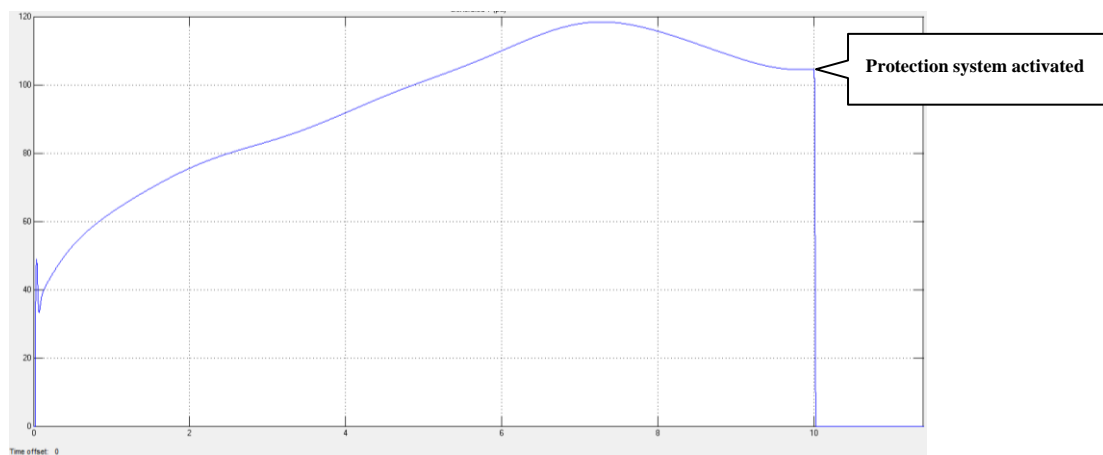
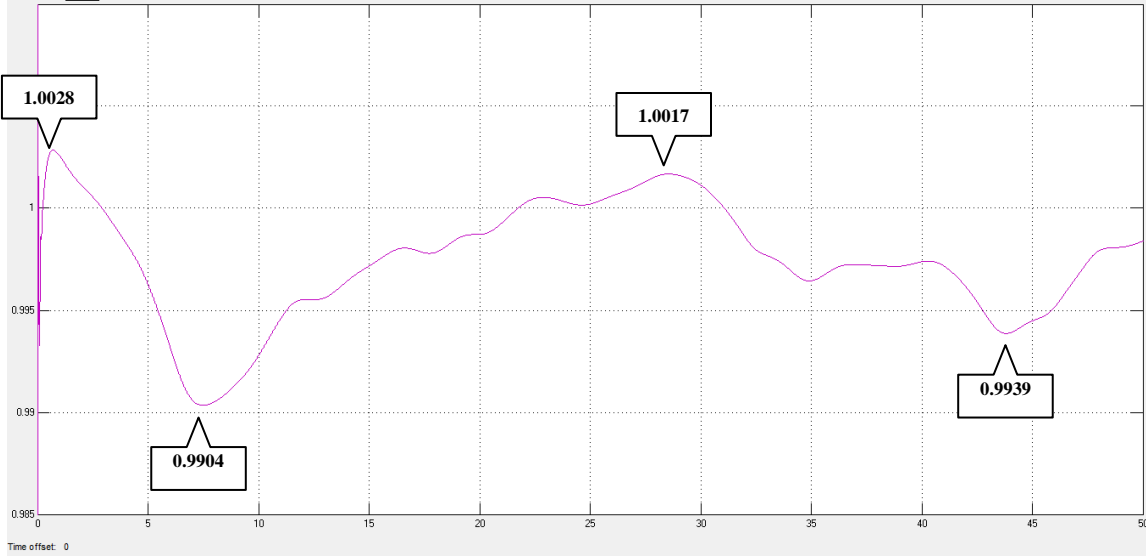

**Figure 10 Power generated of the original system**

The wind power plant has a stabilize power generation from the wind farm, but at 10 second the power generated is spontaneously dived to 0 MW. As mentioned, if the voltage in the system is unregulated a protection system is activated that disconnect the wind farm from the grid. Thus there will be no power generated from the wind farm.

With added reactive power compensation device it can operates to control the reactive power flow in the wind power plant and to stabilize the voltage in the interconnection point of the grid. Figure 11 shows the simulation result of added in reactive power compensation device

to the wind power plant. In the result the voltage peaks are labeled to see how reactive power compensation kept voltage in between 1.0 p.u.



**Figure 11 Voltage regulation by reactive power compensation device**

In correspond to the power generated in the wind power plant, active power are kept in a stabilize state. There is no disturbance in the power generated. Figure 12 shows the power generated in the wind power plant.

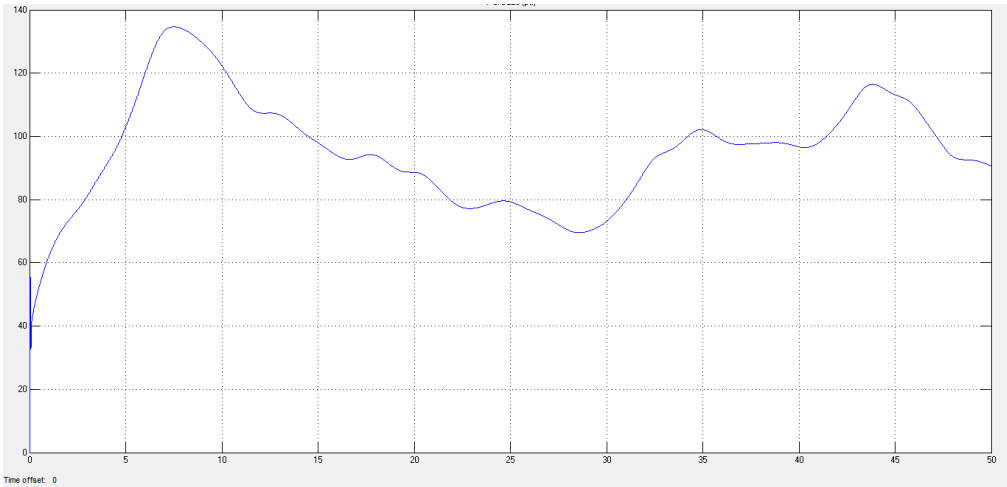

**Figure 12 Power generated with stabilize voltage in the wind power plant**

## 4.2.2 Smoothing Power fluctuation in wind power plant

Section 2.2, discusses the relationship between powers generated and wind speed. Since wind is an uncontrollable factor that varied over time. Therefore, the power generated is also varied. See figure 13 for the simulation result of power generated versus wind speed.

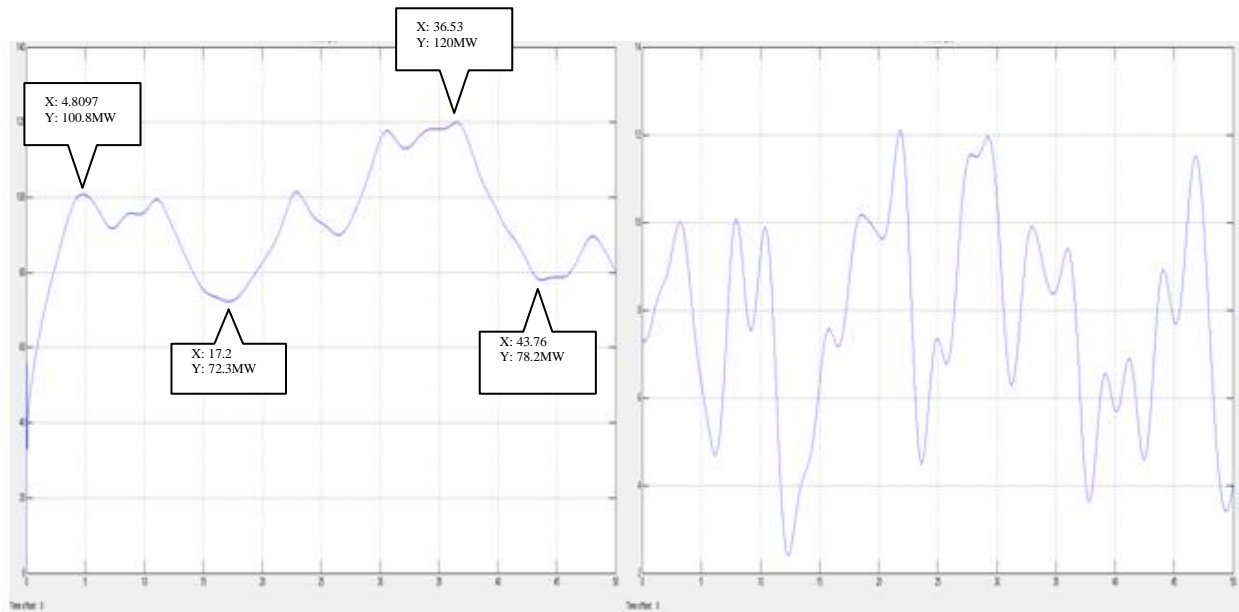

**Figure 13 Power generated (left) versus Wind speed (right)**

Energy storage system can smooth the power fluctuation generated due the wind speed. By controlling the active power flow in the wind power plant it can improve output power efficiency. Therefore, wind power plant can manage the power transmitted and distributed in the network based on the load demands. Figure 14 shows the charge and discharge states of the energy storage in responds to the power demand.

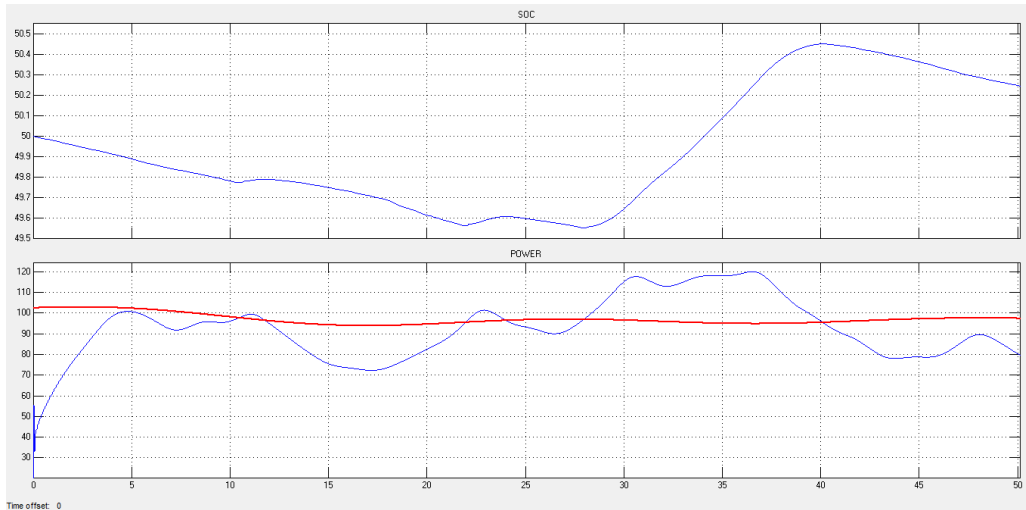

**Figure 14 Battery (Top) charge/discharge characteristic based on the difference between the power generated (bottom, blue) and load (bottom, red)**

The red line is the generated load line and the blue line is the power generated from the wind power plant. In this simulation, it shows two important characteristics. First, if the power generated is higher than the load line, the excess power generated will be stored into the battery storage system. Second, if the power generated is lower than the load line, it will output power to compensate the differences. The output powers of the wind power plant will change according to the load. Figure shows the output result after energy storage is added to the wind power plant.

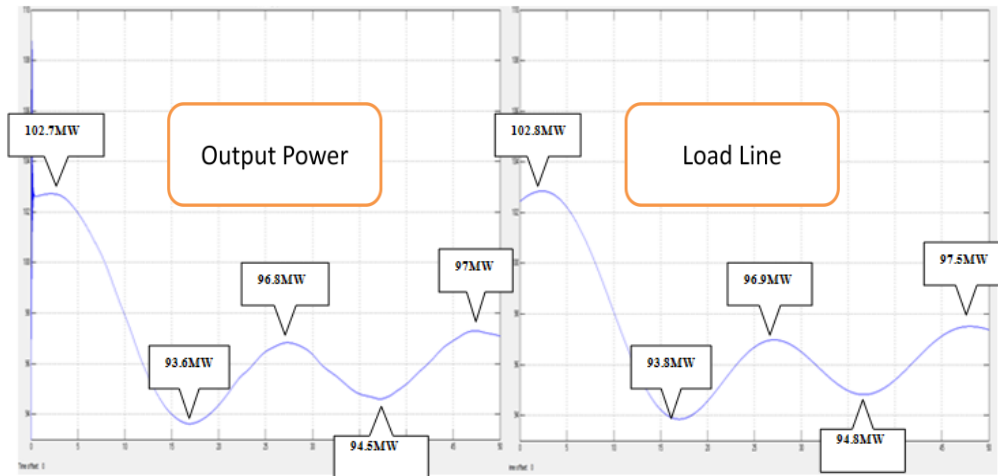
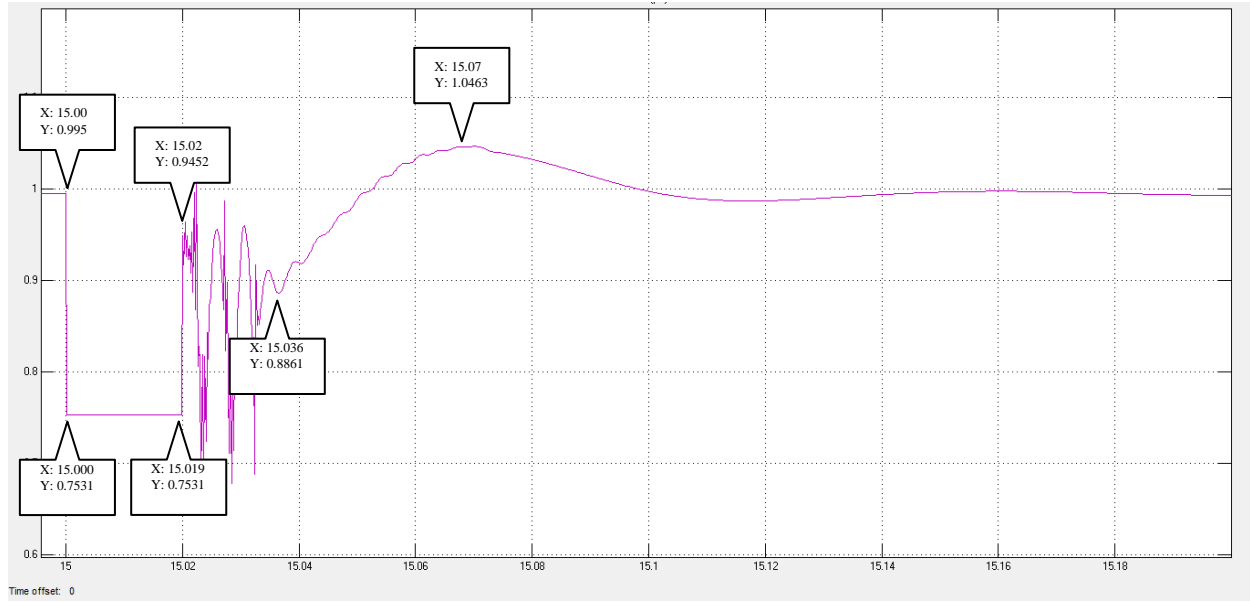

**Figure 15 Output power with energy storage system added**

The output power after energy storage system is implemented in the wind power plant. The high and low peaks value for the output power and the load line are compared to observe their differences. As shown in figure 15 the output power is similar the load line.

#### 4.2.4 External impacts on the wind power plant

Impact from the environment or weather forecast can be an important contribution to the wind power plant stability. These external impacts resulted as a short circuit or faults in the wind power plant. In this simulation a short circuit is added in at 15 second to represent the external impacts on the wind power plant. We want to observe the design system's ability to stabilize the wind power plant after the impact.



**Figure 16 Fault circuit at 15 second**

Figure 1 shows the simulation result of external impact on the wind power plant. When the fault starts, the voltage drop to 0.7531 p.u then stay constant for 0.198 seconds unit it ramp up to 0.9452 p.u at 15.02 seconds. In previous simulation result shows that the voltage at 0.9 p.u can still operates in a stable state. However, right after when the voltage ramp up to 0.9452 p.u it starts to fluctuate randomly for 0.016 seconds and stopped at 15.036 second with 0.8861 p.u. The voltage will peak to 1.0463 p.u at 12.07 second and then stabilize throughout the simulation time.

Voltage instability in an interconnection point of the grid can leads to power disturbance in the wind power plant. This issue has been discussed in pervious section. Figure 17 shows the voltage instability lead to power disturbance in the wind power plant. Between the fault start to end power are fluctuated violently up and down. The highest peak active power ramp up to be 230.58 MW and ramp down to 65.31 MW.

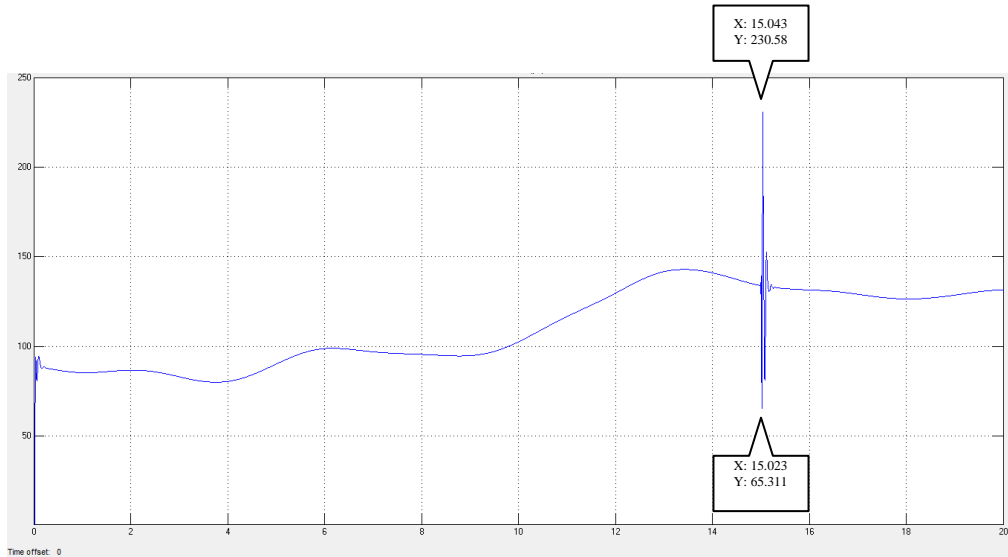

**Figure 17 Power generated**

To prove our designed system can override any continuous external impact on the wind power plant. A subsystem is added into the wind power plant which consists of eight fault circuit. See figure 18 for the circuit schematic. The eight fault circuit will happen every 10 second starting at 15 second of simulation time. In this simulation, we will observe the stability of our design system reacts to multiple faults.

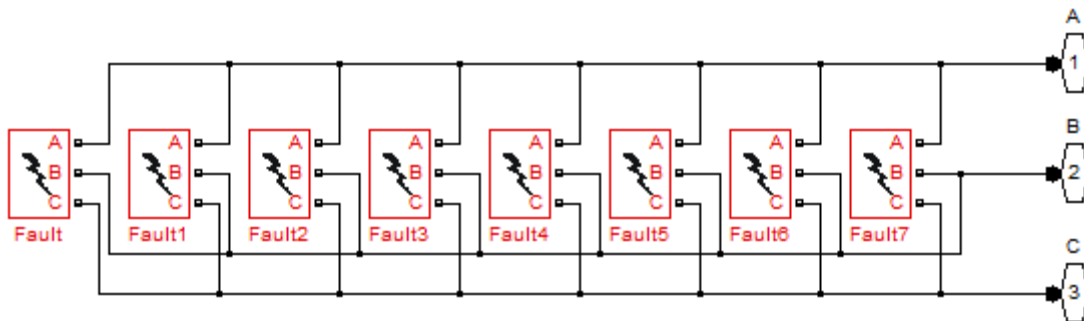

**Figure 18 Faults circuit (subsystem)**

Figure 19 shows the simulation result our design stabilize the system voltage that are disturbed with multiple faults. At the simulation high and low peak values are labeled.



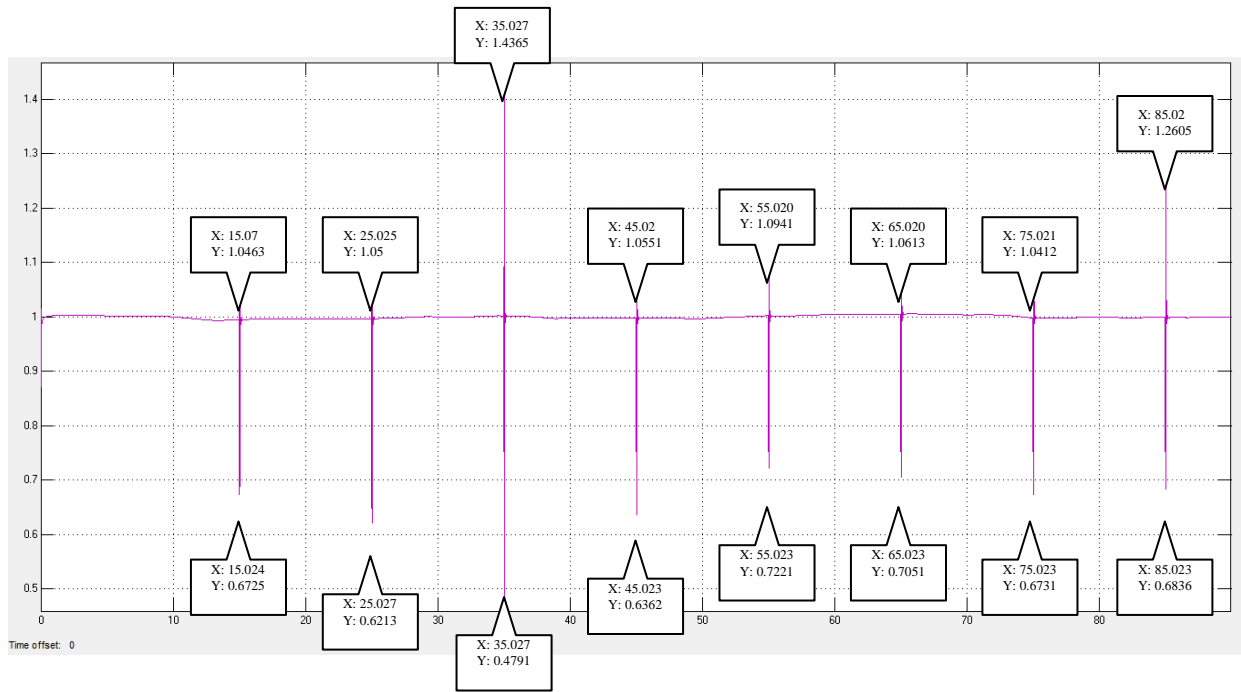

**Figure 19 Eight faults in the wind power plant**

In this simulation result it shows that our design system would maintain stability control of the wind power plant after multiple faults or short circuit.

## Conclusion

Wind power plant is very essential in today's environmental and energy dependable development. A lots of wind power technologies have been researched and numbers of wind farm have been installed to the existing grid. The performance of overall wind power plant depends on the subsystem such as reactive power compensation and energy storage to maintain stability. However, with the increasing capacity of the wind power plant the cost and benefit of these subsystems became unfeasible. The cost for reactive power and energy storage increases as the wind farm capacity increase. In future works, it could be feasible to test wind power plant using combined capacitor and reactive power compensation which could low the cost. For energy storage by determine the capacity that needed for each its applications. Because different

wind power plant require different energy storage application. In this way, the cost of energy storage can be lowered. The overall development of these subsystems in wind power plant depends on their cost.

## Reference

Akhmatov, V. (2003). *Analysis of dynamic behaviour of electric power system with large amount of wind power*. Lyngby: Technical University of Denmark.

Akhmatov, V. (2003). Variable-Speed Wind Turbines with Doubly-Fed Induction Generators Part III: Model with Back-to-back Converters. *Wind Engineering* , 27 (No.2), 79-91.

Anaya-Lara et al, O. (2009). Electricity Generation from Wind Energy. In A.-L. Olimpo, N. Jenkins, E. Janaka, P. Cartwright, & M. Hughes, *Wind Energy Generation: Modelling and Control* (Illustrated ed., p. 269). Chichester, United Kingdom: John Wiley & Sons, Ltd.

Burton et al, T. (2001). *Wind Energy Handbook*. Chichester: John Wiley & Sons Ltd.

Manwell et al, J. F. (2002). *Wind Energy Explained: Theory, Design and Application*. Chichester: John Wiley & Sons, Ltd.

Seyedi, M. (2009). *Evaluation of DFIG Wind Turbine Built-in PSS/E*. Department of Environment and Energy. Goteborg: Chalmers University of Technology .

WWEA. (2010). *Wind Energy Report 2010*. Bonn: World Wind Energy Association.

## Appendix A: Wind power plant parameters

<b>Generator data:</b>	<b>Value:</b>
Nominal Power [VA]	450e6
Line-Line Voltage [Vrms]	575
Frequency [Hz]	50
Stator [Rs, Ls] (p.u)	[0.00706 0.171]
Rotor [Rr, Lr] (p.u)	[0.005 0.156]
Magnetizing Inductance Lm (p.u)	2.9
Inertia constant [H(s)]	5.04
Friction factor [F(p.u)]	0.01
Pairs of poles	3
Initial conditions [s() th(deg) ph_Is(deg) Ir(pu) ph_Ir(deg)]	[0.2 0 0 0 0 0]

<b>Converter data:</b>	<b>Value:</b>
Converter maximum power (p.u)	0.5
Grid-side coupling inductor [L(p.u) R(p.u)]	[0.15 0.0015]
Coupling inductor initial current [IL(p.u) ph_IL(deg)]	[0 90]
Nominal DC bus voltage (V)	1200
DC bus capacitor(F)	300x10000e-6

<b>Turbine data:</b>	<b>Value:</b>
Nominal wind turbine mechanical output power (W)	450e6
Tracking characteristic speeds: [speed_A(p.u)...speed_D(p.u)]	[0.7 0.71 1.2 1.21]
Power at point C (p.u/mechanical power)	0.73
Wind speed at point C (m/s)	12
Pitch angle controller gain [Kp]	500
Maximum pitch angle (deg)	45
Maximum rate of change of pitch angle (deg/s)	2

## Appendix B: Simulation code

```
% Initialization
Power = zeros(1,1); % Power = 0
SOC = 50; % State of Charge at 50%
Ts = 2e-4; % Sampling time at 0.2 ms
Vrms = 575; % Vrms at 575 Vph-ph
phase = randi([-180,180],8,1); % generate random phase lag for wind speed

% clear unused parameters
clear DisplayTurbChar ParVisible c1 c1_c6 c2 c3 c4 c5 c6 xInitial xFinal tout
t Power;
% generate interval time for power change
tpow = flipud(rot90(linspace(0,120,length(P.signals.values(:,1)))));
% generate reference voltage
Pref = Prefout.signals.values(:,1);

% calculate when Power higher or lower than reference
Higher = zeros(length(P.signals.values(:,1)),1);
Lower = zeros(length(P.signals.values(:,1)),1);

for i = 102:length(P.signals.values(:,1)),

    if(P.signals.values(i,1) > Pref(i,1))
        Higher(i,1) = P.signals.values(i,1) - Pref(i,1);
    else
        Lower(i,1) = Pref(i,1) - P.signals.values(i,1);
    end

end

end
% clear dummy variables
clear i;

% Update
% update State of Charge
SOC = SOCout.signals.values(length(SOCout.signals.values(:,1)),1);
% update Power
Power = zeros(length(Pin.signals.values(:,1)),1);
Power(:,1) = [((-1)*Pin.signals.values(:,1) -
Pout.signals.values(:,1))/(1e6)];
% clear Pin Pout SOCout;
```