

DESIGN & PROTOTYPE OF A KNEE MRI RF COIL ENCLOSURE

A Major Qualifying Project Report:

submitted to the Faculty

of the

WORCESTER POLYTECHNIC INSTITUTE

in partial fulfillment of the requirements for the

Degree of Bachelor of Science

by



Stephen Bergeron



Gary Hamilton

Ryan LeBlanc

Date: April 27, 2006

Approved:

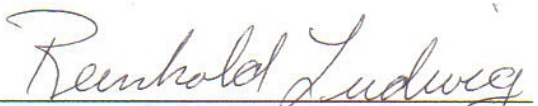
Professor John M. Sullivan, Major Advisor

Professor Reinhold Ludwig, Co-Advisor

1. medical
2. imaging
3. knee

Abstract

Recognizing the need for greater resolution images produced from Magnetic Resonance (MR) technology, we designed an adaptable, rotating radiofrequency (RF) coil enclosure system specifically intended for knees. Machined out of magnetically transparent materials in the WPI Washburn labs, we used manual and automated mini-mills to fabricate a practical RF enclosure capable of ergonomically accommodating extremities and capturing images at virtually any angle on a single plane. Our prototype can accommodate a variety knee sizes and RF coil designs.

Executive Summary

It is becoming more feasible to use non-invasive medical techniques to examine inner body tissue. While there are many different techniques that can be used, a prevalent method of imaging the body is Magnetic Resonance Imaging (MRI). Over the past 50 years, the field of medical imaging, and more specifically MRI, has expanded and evolved into a medical technique that can distinguish different tissue types within the body. The medical industry is continually striving for increased imaging resolution and site specific imaging tools. This project focused primarily on the knee, though as later research revealed, the resultant project might be used on a variety of different appendages.

There are several developers of MRI coil holders on the market today. General Electric, Philips, and Siemens are companies that have made significant investments in this technology. However, most of the current RF coil holder designs feature a static system that has little adjustment for imaging at different angles or extremity sizes. Our innovative project features a rotating coil system that can image a full 360 degrees around the human knee. This innovation came through several different design iterations and feature evolutions.

The final open-air, rotating design can be seen in Figure 1. This enclosure was modeled in SolidWorks and fabricated at the WPI HAAS milling laboratory.

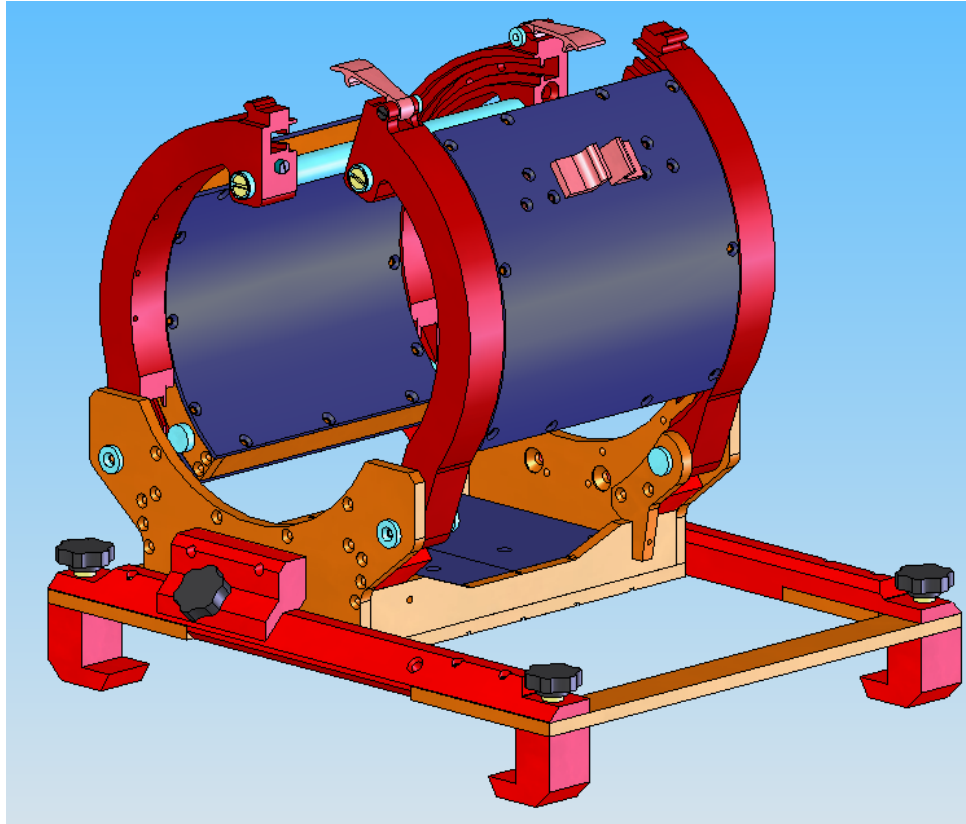

Figure 1: Model of the final design in SolidWorks.

The entire project had to be constructed out of non-ferrous material. Therefore, a variety of plastics were employed as materials for construction. Delrin was used for its machinability for intricate features. Polycarbonate and acrylic plastics were used for simple components due to their low cost. With the aid of the machine shop staff and the utilization of the Haas VF-2 CNC mini-mills, manual mills, and manual and lathes, our group successfully constructed the project.

The fabricated RF coil knee enclosure satisfied the design constraints and objectives. A redesign of the slide release mechanism and RF coil mounting surface are suggested. However, the unit performs as designed and provides a new method of imaging compared to existing commercial coil enclosures.

Acknowledgments

We would like to thank Lab Machinist Jim Johnson for teaching us the finer points of machining with manual mills. Lab Machinist Michael O'Donnell was also extremely helpful during our long hours up in the lab, especially when CNC machining was required. We would also like to thank Professors John Sullivan and Reinhold Ludwig for their guidance.

Table of Contents

ABSTRACT	II
EXECUTIVE SUMMARY	III
ACKNOWLEDGMENTS.....	V
TABLE OF CONTENTS	VI
TABLE OF FIGURES	VII
TABLE OF TABLES	IX
GOAL STATEMENT	1
INTRODUCTION	2
BACKGROUND.....	4
DEFINING MAGNETIC RESONANCE IMAGING.....	4
HISTORY OF NUCLEAR MAGNETIC RESONANCE.....	4
THE NMR PHYSICS	5
<i>Gradient Coil System</i>	<i>11</i>
<i>Magnets.....</i>	<i>12</i>
<i>RF Coil System.....</i>	<i>14</i>
SAFETY ASPECTS.....	15
DEVICES ON THE MARKET.....	15
HUMAN GEOMETRY AND INJURY CONSIDERATIONS.....	17
METHODOLOGY.....	18
TASK SPECIFICATIONS.....	20
PRELIMINARY DESIGN CONCEPTS	21
<i>Design A – Circular Surface Coils in a U-Holder:.....</i>	<i>21</i>
<i>Design B – Saddle Coils in a U-Holder</i>	<i>23</i>
<i>Design C – Saddle Coils in U-Holder with Top Door.....</i>	<i>25</i>
<i>Design D – Variable-Position Rotating Saddle Coil.....</i>	<i>27</i>
FINAL DESIGN	28
<i>General Model Configuration.....</i>	<i>29</i>
<i>Rotating Coil Holder.....</i>	<i>34</i>
<i>Arm Rail System</i>	<i>38</i>
<i>Base</i>	<i>41</i>
<i>Table-top Base Rail System.....</i>	<i>45</i>
<i>Materials.....</i>	<i>47</i>
<i>Fabrication.....</i>	<i>49</i>
RESULTS.....	56
COMPLETE ENCLOSURE.....	56
BASE	57
ARMS	60
BASE CLAMP	64
COIL HOLDER.....	65
CONCLUSIONS.....	67
RECOMMENDATIONS	69
BIBLIOGRAPHY	72
APPENDICES	74

TECHNICAL DRAWINGS	74
<i>Base Clamp Components</i>	74
<i>Base Components</i>	78
<i>Two Arm Components</i>	92
<i>RF Coil Enclosure Components</i>	99
MASTER PARTS LIST	109
RENDERED IMAGE OF COMPLETED ASSEMBLY	111
DETAILED COST ANALYSIS SHEET:	112

Table of Figures

FIGURE 1: MODEL OF THE FINAL DESIGN IN SOLIDWORKS.	IV
FIGURE 2: EXAMPLE MODEL OF A KNEE TAKEN WITH A MRI.	2
FIGURE 3: MRI DEVICE.	3
FIGURE 4: DIAGRAM OF THE PRECESSION OF A PROTON IN A STATIC MAGNETIC FIELD.	6
FIGURE 5: SHIFT IN DIRECTION OF THE MO FIELD DUE TO A RF PULSE.	8
FIGURE 6: T2 vs. TE (LEFT) & T1 vs TR (RIGHT).	9
FIGURE 7: T2 DECAY CURVES OF FAT, WATER, AND SOLID TISSUE:	10
FIGURE 8: THE FOUR QUADRANTS OF A TYPICAL TRANSVERSE MRI GRADIENT COIL.	11
FIGURE 9: OPEN DESIGN MRI SCANNER.	13
FIGURE 10: FOUR MAIN RF COIL TYPES.	14
FIGURE 11: LARGE KNEE COIL - SOLENOIDAL DESIGN.	16
FIGURE 12: 8 CHANNEL HIGH RESOLUTION KNEE ARRAY – LEFT/RIGHT OFFSETS AND PIVOT ROTATION FOR POSITIONING AND COMFORT.	16
FIGURE 13: 8-CHANNEL SENSE™ KNEE COIL.	16
FIGURE 14: ARTOSCAN M SYSTEM DUAL PHASED ARRAY RF COILS.	16
FIGURE 15: SIGNAL PLUS™ KNEE - CIRCULAR MULTI-CONDUCTOR RECEIVER COIL.	16
FIGURE 16: QD KNEE COIL - QUADRATURE COIL, TRANSMIT/ RECEIVE.	16
FIGURE 17: THE LEO III TRANSMIT/RECEIVE KNEE COIL - BIRDCAGE, SPLIT-TOP DESIGN, 2-CHANNEL, QUADRATURE DESIGN.	16
FIGURE 18: LEGEND 5000 PHASED ARRAY KNEE – QUADRATURE, COIL MECHANICALLY SPLIT INTO TWO HALVES.	16
FIGURE 19: HUMAN LED MODELED AFTER SPECIFIED HUMAN GEOMETRY.	18
FIGURE 20: PROJECT METHODOLOGY FLOW CHART.	19
FIGURE 21: TOP VIEW OF CIRCULAR COILS IN DESIGN A.	22
FIGURE 22: ISOMETRIC VIEW OF CIRCULAR COILS IN DESIGN A.	22
FIGURE 23: FRONT VIEW OF CIRCULAR COILS IN DESIGN A.	22
FIGURE 24: SIDE VIEW OF CIRCULAR COILS IN DESIGN A.	22
FIGURE 25: TOP VIEW OF SADDLE COILS IN DESIGN B.	24
FIGURE 26: ISOMETRIC VIEW SADDLE COILS IN DESIGN B.	24
FIGURE 27: FRONT VIEW SADDLE COILS IN DESIGN B.	24
FIGURE 28: SIDE VIEW SADDLE COILS IN DESIGN B.	24
FIGURE 29: TOP VIEW OF U-HOLDER IN DESIGN C.	26
FIGURE 30: ISOMETRIC VIEW OF U-HOLDER IN DESIGN C.	26
FIGURE 31: FRONT VIEW OF U-HOLDER IN DESIGN C.	26
FIGURE 32: SIDE VIEW OF U-HOLDER IN DESIGN C.	26
FIGURE 33: TOP VIEW OF VARIABLE-POSITION ROTATING SADDLE COIL IN DESIGN D.	28
FIGURE 34: TOP VIEW OF TOP VIEW OF VARIABLE-POSITION ROTATING SADDLE COIL IN DESIGN D.	28
FIGURE 35: TOP VIEW OF TOP VIEW OF VARIABLE-POSITION ROTATING SADDLE COIL IN DESIGN D.	28
FIGURE 36: TOP VIEW OF TOP VIEW OF VARIABLE-POSITION ROTATING SADDLE COIL IN DESIGN D.	28
FIGURE 37: DESIGN D.	30
FIGURE 38: ISOMETRIC VIEW OF THE FINAL CAD MODELED RF COIL ENCLOSURE WITH LEGS.	32
FIGURE 39: POSITION OF THE LEGS MAGNET WITH 12 INCH OUTER DIAMETER ARMS.	33
FIGURE 40: VIEW OF THE KNEE THROUGH THE COIL HOLDER FRAME.	33
FIGURE 41: MODELS OF THE SCREWS AND PINS - #10, M8X1.25, AND TWO ARM PINS, RESPECTIVELY.	34

FIGURE 42: ELECTRONICS ENVELOPE IN THE COIL HOLDERS.....	35
FIGURE 43: COIL HOLDER PIN LOCKING MECHANISM	36
FIGURE 44: RADIAL LOCATION OF THE PIN LOCKING MECHANISM.....	36
FIGURE 45: WIRE GUIDE.....	37
FIGURE 46: STAND-OFF BEARING.....	37
FIGURE 47: FINAL ASSEMBLY OF A SINGLE COIL HOLDER WITH CLEAR OUTER COVER.....	37
FIGURE 48: EXPLODED VIEW OF THE ROTATING COIL HOLDER SUBASSEMBLY WITH BOM TABLE.....	38
FIGURE 49: CAD MODEL OF HALF OF THE ARM RAIL SYSTEM.....	39
FIGURE 50: PEG AND HOLE ALIGNMENT WITH CROSS-BRACING ROD.....	39
FIGURE 51: LOWER BASE PORTION OF THE ARM RAIL SYSTEM.....	40
FIGURE 52: EXPLODED VIEW OF THE ARM RAIL SUBASSEMBLY WITH BOM TABLE.....	40
FIGURE 53: ISOMETRIC VIEW OF THE COMPLETE BASE SUBASSEMBLY INCLUDING THE BASE GUIDE RAILS.....	41
FIGURE 54: UPPER ARM RAIL SYSTEM ANCHOR POINT.....	42
FIGURE 55: LOWER ARM RAIL ATTACHMENT TO BASE.....	42
FIGURE 56: SIDE VIEW OF THE BASE INCLUDING THE TABLE RAIL THUMB SCREWS, BRACKETS, AND SIDE CUTOUTS.....	43
FIGURE 57: VIEW OF THE CABLE COILING (MAGENTA) AND ELECTRONICS AREAS (YELLOW).....	43
FIGURE 58: CABLE PATHWAY FOR A COIL HOLDER WITH MAXIMUM (YELLOW) AND MINIMUM (GREEN) CABLE SLACK.....	44
FIGURE 59: EXPLODED VIEW OF THE FINAL BASE SUBASSEMBLY WITH BILL OF MATERIALS.....	45
FIGURE 60: FINAL DESIGN OF THE TABLE-TOP BASE RAIL SUBASSEMBLY.....	45
FIGURE 61: BEVELED EDGES ON THE TABLE RAIL.....	46
FIGURE 62: LOCK POSITIONS ON THE TABLE RAILS.....	46
FIGURE 63: EXPLODED ISOMETRIC VIEW OF THE TABLE-TOP BASE RAIL SUBASSEMBLY INCLUDING A BILL OF MATERIALS.....	47
FIGURE 64: FIXTURING ARMS FOR CNC MACHINING.....	50
FIGURE 65: THE ARM ASSEMBLY.....	50
FIGURE 66: SPACING PLAN FOR BASE PARTS ON 3/8" PLATE.....	51
FIGURE 67: BASE CLAMP MECHANISM.....	52
FIGURE 68: FIXTURING SIDE COIL GUIDE FOR CNC MACHINING.....	55
FIGURE 69: COMPARISON OF CAD MODELED RF COIL ENCLOSURE TO PHYSICAL ASSEMBLY.....	57
FIGURE 70: OVERALL BASE COMPARISON.....	58
FIGURE 71: ELECTRONICS AND WIRING BAY COMPARISON.....	58
FIGURE 72: BASE WIRE TRACK COMPARISON.....	59
FIGURE 73: INNER WIRE TRACK COMPARISON.....	59
FIGURE 74: BASE THUMB SCREW COMPARISON.....	59
FIGURE 75: WIRE GUIDE HOLE COMPARISON.....	60
FIGURE 76: ARM FRONT VIEW.....	61
FIGURE 77: ISOMETRIC VIEW OF THE ARM SUBASSEMBLY COMPARISON.....	61
FIGURE 78: FULL VIEW OF THE ARM SUBASSEMBLY COMPARISON.....	62
FIGURE 79: INNER BEARING & GUIDE TRACK COMPARISON.....	62
FIGURE 80: LATCH HOOK COMPARISON.....	63
FIGURE 81: FUNCTIONALITY COMPARISON OF ARM LATCH.....	63
FIGURE 82: ARM MACHINING ERROR.....	64
FIGURE 83: BASE CLAMP MODEL.....	65
FIGURE 84: MODELS OF THE COIL HOLDER.....	66
FIGURE 85: COIL HOLE TOP AND BOTTOM PARTS.....	70
FIGURE 86: COMPLETED COIL ENCLOSURE WITH EXPLODED VIEW.....	70
FIGURE 87: REVISED LOCKING MECHANISM.....	71

Table of Tables

TABLE 1: MISCELLANEOUS DIMENSIONS.	17
TABLE 2: DECISION MATRIX FOR THE FINAL PRODUCT DESIGN.	29
TABLE 3: HUMAN ENGINEERING DIMENSIONS.	31
TABLE 4: RAW MATERIAL COMPARISON	48
TABLE 5: COST ANALYSIS.....	48
TABLE 6: FINAL ASSEMBLY MODEL TREE.	53

Goal Statement

Our goal was to conceptualize, design, and fabricate a functional prototype of a RF coil enclosure that is compatible with commercial magnetic resonance imaging systems. The prototype must be capable of capturing images of a human knee at multiple angles.

Introduction

The medical field has advanced its diagnosis of injury through the use of non-invasive medical procedures such as magnetic resonance imaging. With the ability to distinguish between different types of tissues and fluids in the body, MR imaging allows us to take a glimpse into the human body. Without the use of surgery or any other type of intrusive observation method, MR imaging, shown in Figure 2, allows doctors to visualize problems within a patient and make better decisions based on comprehensive images.

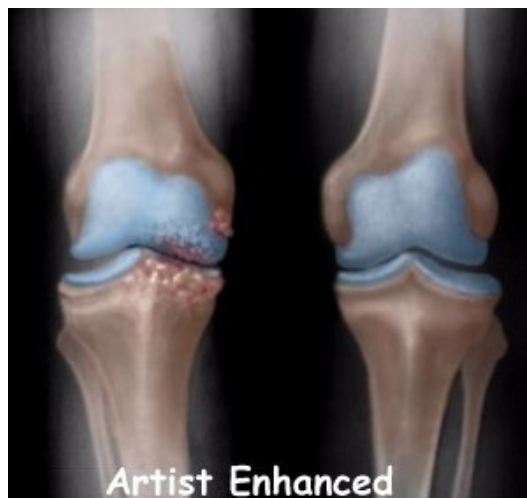

Figure 2: Example model of a knee taken with a MRI.

(A Patient's Guide to Osteoarthritis of the Knee, 2005)

An MRI of the entire body may be helpful in certain circumstances, but frequently the area in question is very site specific. A typical MR system used to image the human body can be seen in Figure 3. Due to the limitations of MR imaging, the closer the radio frequency coils are to the imaging site, the greater the resolution of the image. Ideally, an RF coil would wrap around the area of interest for a high quality image. This is extremely important for knee imaging because of the complicated nature of typical knee injuries. In

conventional knee coil holders, certain body types or injuries could not be easily accommodated.



Figure 3: MRI Device.

(Devitt, 2003)

Our design eliminated some of the problems with conventional knee MRI coil holders. The final design featured housing for a free rotating, 4 channel coil design. This enabled a medical operator to image a full 360 degrees around the knee. The designed also featured the ability load an injured knee into the coil holder without passing the lower leg through the holder. The design culminated into a prototype that was constructed using the Worcester Polytechnic machining facilities. Each step of the project process is outlined in the following chapters of this report.

Background

Magnetic resonance (MR) is based on the reaction between an externally applied magnetic field and spinning nuclei within the body. Cerium and argon are the only two elements that do not contain at least one naturally occurring isotope that possesses a spin. All other elements whose isotopes naturally spin can be examined, making MR an extremely useful unobtrusive technique for imaging the human anatomy (Brown et al. 1-5).

Defining Magnetic Resonance Imaging

MRI is a tomographic imaging technique that produces images of internal physical and chemical characteristics of an object from externally measured nuclear magnetic resonance signals (Lauterbur et al 1-2). For a full body MR session the patient is placed in a large cylindrical magnetic enclosure. The patient must lie still on a narrow table that passes through the magnetic field while the image is being taken. This entire process can take upwards of an hour, but with the development of newer scanners and more accurate software this time is being constantly reduced. If a higher contrast is desired, a patient will be administered an IV with dye which can also increase the image acquisition time.

History of Nuclear Magnetic Resonance

Felix Bloch and Edward Purcell observed the effects of Nuclear Magnetic Resonance (NMR) in bulk matter back in 1946. Both were awarded the Nobel Peace Prize for their observations. Their formulations enabled one to uniquely encode spatial

information from the activated MR signals detected outside of an object. MRI operates in the radio-frequency (RF) range (Hornak 1). The MRI process does not use ionizing radiation and does not have the associated potential harmful effects (Lauterbur et al 2-4).

The NMR Physics

Nuclear magnetic resonance (NMR) or equivalently Magnetic Resonance Imaging (MRI) is based on the property that most nuclei possess spin when immersed in a static magnetic field and subsequently exposed to another oscillating magnetic field. The most abundant source of nuclei that spin is the hydrogen protons in water molecules. The human body is composed of almost 70% water and hydrogen rich adipose tissue. A list of the common elements whose atomic nuclei can be detected using NMR includes hydrogen, phosphorus, sodium, nitrogen, carbon, and fluorine. In fact, argon and cerium are the only two elements that do not have naturally occurring isotopes and therefore can not be viewed using NMR (Brown et al. 1-5).

When the isotopes of these elements are immersed in a static electric field, B_0 , the spin of the nuclei causes them to align to the direction of the field as if they were miniature magnets. During the alignment of a group of nuclei, the protons of the nuclei can align in two possible orientations depending on the energy state of each proton. At any temperature, the ratio of spins oriented in each direction can be described by the Boltzmann equation. This equation shows that the ratio of protons having higher energy spins (N^-) to that of those having lower energy spins (N^+) is equal to the following exponential function,

$$N^-/N^+ = e^{-E/kT}$$

where E is the energy difference between the spin states, k is Boltzmann's constant (1.3805×10^{-23} J/Kelvin), and T is the temperature in degrees Kelvin (Brown et al. 4-7).

For a decrease in temperature, the equation predicts the ratio of higher energy spins to that of lower energy spins will also decrease. The number of spins and the difference in energy between these levels is proportional to the strength of the static field, B_0 (Hornak 23-24).

The static field also causes the protons to precess, or rotate, about an axis parallel to the static field axis. This axis is typically in the positive z-direction in an x-y-z coordinate system. The protons are tilted slightly away from the z-axis causing them to transcribe paths in the x-y plane, as shown in Figure 4 (Brown et al. 6-7).

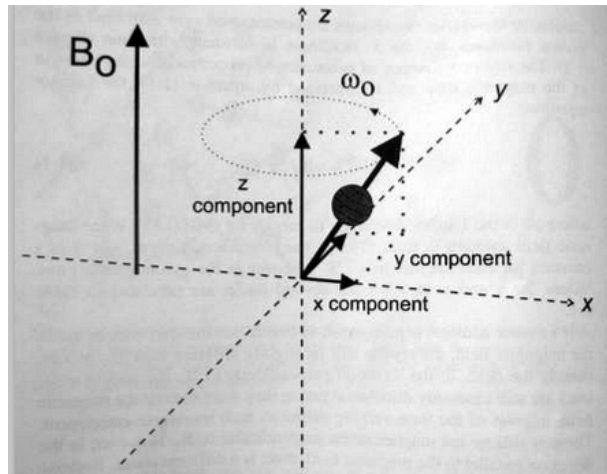

Figure 4: Diagram of the Precession of a Proton in a Static Magnetic Field.

The rate of precession is given by the Lamour equation, where ω_0 is the Lamour frequency in MHz, γ is the gyromagnetic ratio (a constant specific to each isotopic element in $s^{-1} T^{-1}$), and B_0 is the static magnetic field strength with units of teslas (T) (Hornak 31-33).

$$\omega_0 = \gamma B_0 / 2\pi$$

The net difference in spins yields an induced magnetic field (M_0), or net magnetization, which is the vector sum of the individual protons parallel to the static field. The alignment of the induced magnetic field to the static field represents the lowest energy configuration for the protons and is the arrangement that they will return to when stimulated by external energy sources. Fluctuations in the induced field are the source of the signal in NMR. Since a larger static field yields a greater induced field due to the number of particles exhibiting spin, the potential signal produced by M_0 is also much greater. For a given static field strength and gyromagnetic ratio, a proton can absorb energy at a certain frequency, ν , in the form of a photon based on the equation below. The value for the gyromagnetic ratio of the hydrogen isotope Protium is 42.577 MHz T⁻¹. Protium is the isotope targeted in most NMR imaging of tissue (Brown et al. 3).

$$\nu = \gamma B_0$$

One of the simplest ways to energize protons is by directing a pulse of radiofrequency (RF) energy on the sample in a direction perpendicular to the direction of the static field. The perpendicular direction is indicated as another field designated B_1 . During the pulse, the protons absorb energy of a frequency described by Lamour's equation. If the transmitter of the RF pulse is left on with a great enough amplitude for a certain duration, M_0 will deflect away from its equilibrium position eventually rotating into the transverse plane. M_0 is now along a vector perpendicular to both B_0 and B_1 , known as a 90 degree pulse as seen in Figure 5 (Brown et al. 9-11).

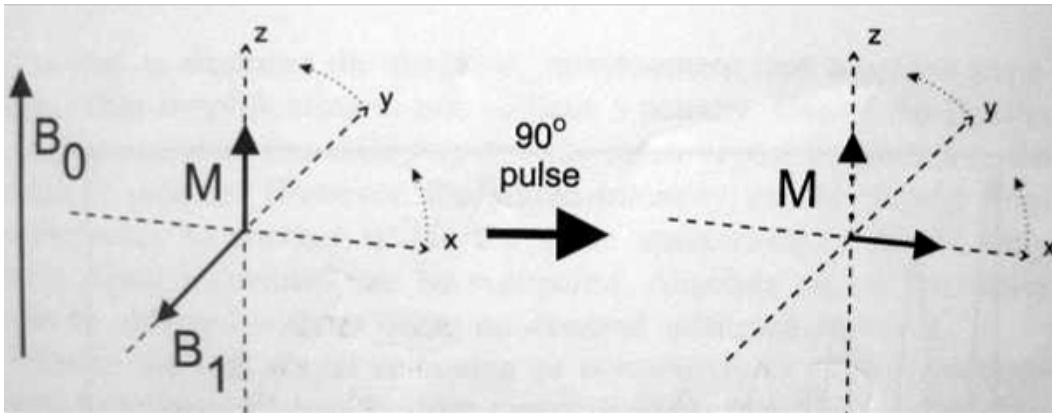

Figure 5: Shift in Direction of the M_0 Field Due to a RF pulse.

Due to the greater number of protons having a lower energy spin, the energy change during the pulse yields a net absorption of energy. After the pulse, the protons emit this absorbed energy at the same frequency as M_0 realigns to an equilibrium position. This absorption and remission of energy correlates to a change in spin energy level and is characterized by the Larmor frequency, referred to as the resonant frequency. For clinical MRI, the frequency range used in hydrogen imaging is between 15 to 80 MHz (Hornak 38). If a loop of wire is arranged perpendicular to the transverse plane, the emitted energy can induce a voltage in the wire, which is the NMR signal. The signal strength decays over time and is called free induction decay (FID). The process of energy remission by the protons is called relaxation. The components that define the signal are the amplitude based on the strength of M_0 , frequency based on the static field frequency, and phase relative to the RF transmitter phase (Brown et al. 11).

MRIs are rich in information content; meaning that a single pixel is dependent on a multitude of variables. The three main variables affecting each pixel are:

ρ – Nuclear Spin Density

T_1 – Spin Lattice relaxation time

T_2 – Spin-Spin relaxation time

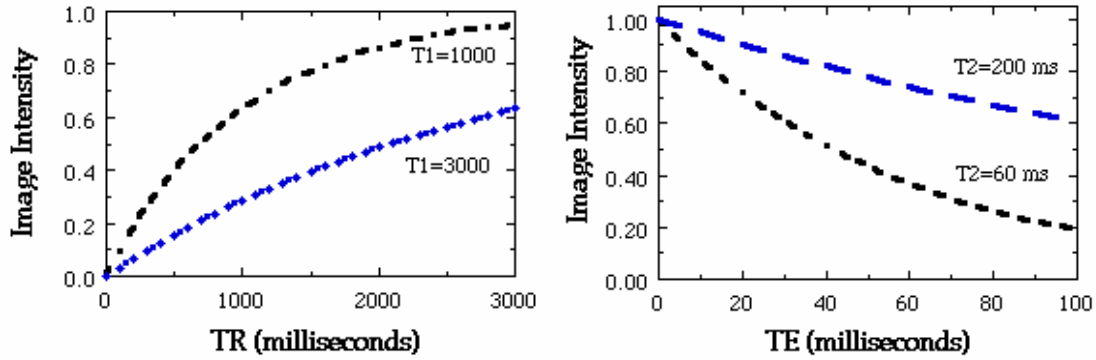

Figure 6: T2 vs. TE (left) & T1 vs TR (right).

(Weisskoff, Ph.D.)

Imaging results can be enhanced or made worse by these set of operator-selectable parameters:

TR – Repetition time

TE – Echo time

α – Flip angle

Notice that at each point (A, B, & C) in Figure 7, the maximum intensity (image contrast) of either fat, solid, or H₂O varies with time. At point B, the image intensities of both water and fat are the same, which would result in poor image quality due to a lack of contrast between the two media. Therefore, an MR image obtained from the same part on the body can look dramatically different when analyzed with different data acquisition protocols (Lauterbur et al 3-4).

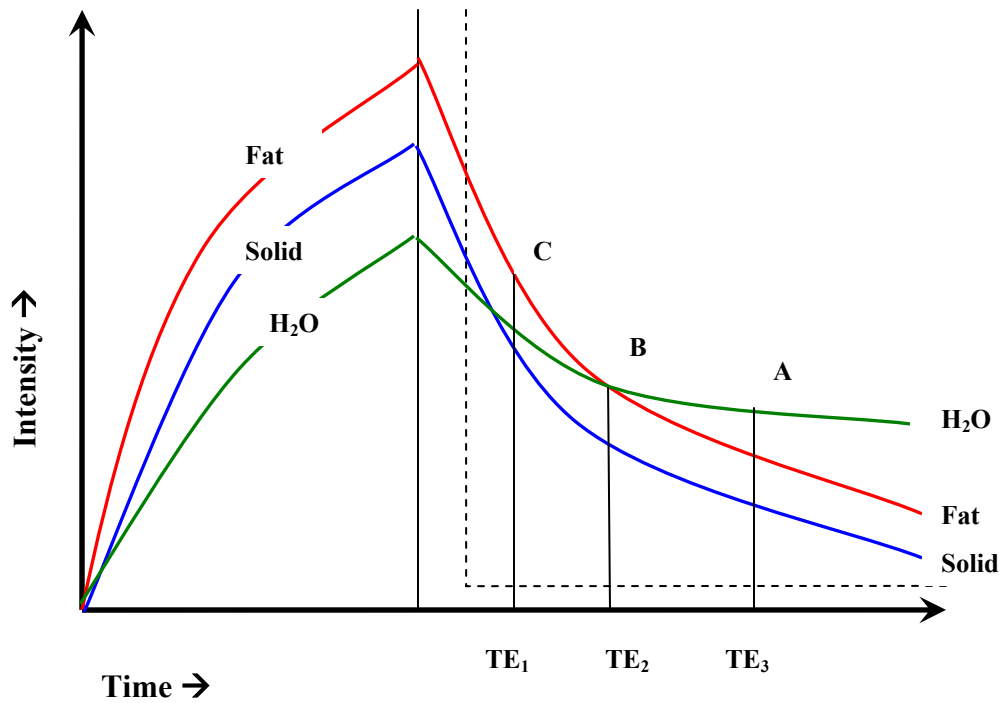

Figure 7: T₂ Decay Curves of Fat, Water, and Solid Tissue:

Often times, a full body MRI can be impractical when trying to image an appendage. If the target area is just in the chest or a limb then a lot of processing time will be wasted on imaging the rest of the body. Also this can cause a loss in resolution of the target area. For this reason, a variety of different site specific MRI machines have been developed. Although these MRI systems may be designed for imaging specific areas of the body, their underlying subsystems are generally the same.

Gradient Coil System

The magnetic field gradient system typically consists of three orthogonal gradient coils. These gradient coils are designed to produce time-dependent magnetic fields, shown in Figure 8. The gradient coils are critical to the operation of MRI because they help with signal localization (Lauterbur et al 1-2).

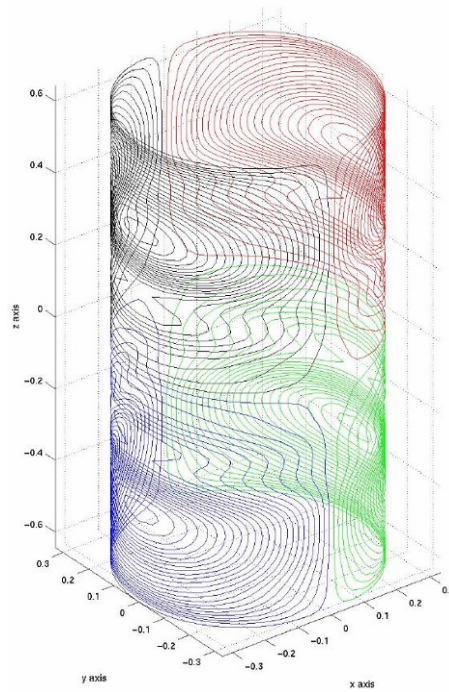

Figure 8: The Four Quadrants of a Typical Transverse MRI Gradient Coil.

(Head)

There are the 4 main aspects that determine the quality of gradient coil system.

1. Maximum Gradient strength
2. Rise time
3. Duty cycle
4. Technique for eddy current compensation
5. Higher gradient strengths allow for thinner image slice (Brown et al. 1-5).

Magnets

For most clinical MRI machines (from 0.2 T to 1.5 T being the most popular field strength choice) a superconducting magnet must be used to generate the high value magnetic field. To do this, a superconducting alloy of niobium/titanium (NbTi) is most commonly used. The conducting wires of the magnet are then suspended in liquid helium to absorb the heat from the wires of the magnetic element. The alloy magnet wires can be cooled down to approximately 4 degrees Kelvin using liquid helium inside the magnet chamber. Older systems used liquid nitrogen as well as helium and other insulating materials to cool the wires. These older systems were eventually replaced because the helium inside was being boiled off so quickly that the maintenance costs to replace the fluid were extremely high. Some of the newer units however, offer helium refill rates only every 7 years.

The superconducting magnets are built in a tube like geometry and have the patient passed through the field (Resources for MRI Students). Usually there is a thin bed that the patient lies on. This bed is then moved into the field and the “sweet spot” is then aligned with the proper region of the patient that is under medical examination. The sweet spot is where the gradient coil exhibits the most linear frequency function and allows for the best possible image quality.

There are other alternatives to a superconducting magnet that are used in specialized clinical applications. A resistive magnet is one made by passing a high current through hundreds of turns of wire wrapped around a central iron core. This type of magnet does not require liquid gasses like a superconducting magnet but does have very high electrical power consumption. Approximately 50kW of electrical energy is used for

a 0.15 T field (very weak) and increases for stronger fields. This type of magnet however does offer some advantages. The overall weight of a resistive magnet is much less than that of a superconducting magnet, which offers easier installation and maintenance. Also while this type of magnet requires a large amount of electricity the overall operating costs are less than superconducting magnets (Young 35-55).



Figure 9: Open Design MRI Scanner.

(Resources for MRI Students)

The resistive magnet allows for alternative MR geometries for special case and claustrophobic patients. An example of this can be seen in Figure 9 (Resources for MRI Students). This system is exceptionally useful for patients with a high demand life support system. The open air nature of this type of magnet makes it another viable MRI option.

RF Coil System

The RF system basically consists of a transmitter coil that is able to produce a rotating magnetic field. This field is also known as the B1 field. Within the RF system, a single coil can act as both a transmitter and receiver, i.e. a transceiver coil. The transmitter and receiver coils are usually called RF coils because they resonate at a radio frequency.

A desirable feature of the RF component is to provide a uniform B1 field and high detection sensitivity. To do so, a MR system is often equipped with several RF coils of varying shapes and sizes. The most common types of RF coils are solenoid coils, saddle coils, birdcage coils and surface coils as shown in Figure 10.

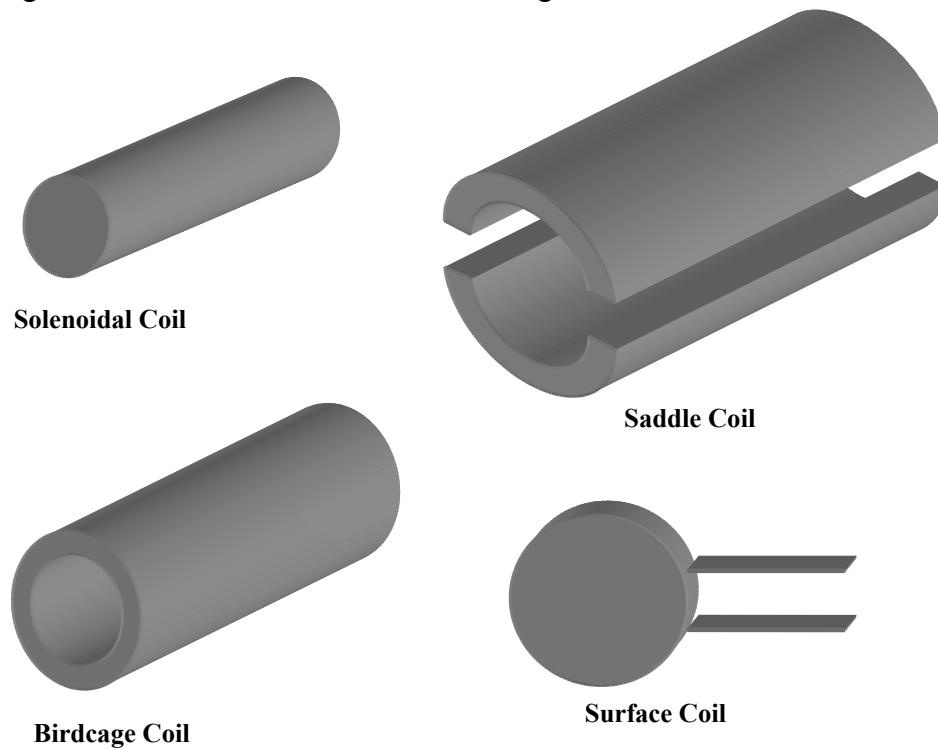

Figure 10: Four Main RF Coil Types.

Safety Aspects

Serious safety issues are associated with MRI testing. Since the machine utilizes very strong magnets and fields, any metal in the vicinity of the machine could cause a very serious risk for the patient. For this reason, patients are screened very carefully before the actual testing occurs. Small metal objects such as pens, fasteners, hair pins and other common materials could create a very serious risk if allowed into the testing area. Other metal objects that are inside of the body of the patient, such as pacemakers, surgical screws or artificial joints, can be pulled out of the body creating a “reverse bullet” effect if not carefully screened for before the MRI occurs.

Outside of the very serious risk of metal, there are little affects of MRI testing. A patient will not feel any pain, nor will require any serious medical treatment after the test. The tests can sometimes come out unclear if a patient is not completely still during the process. A sedative may be given to the patient if they are unable to remain still. There has been no research to show that magnetic fields cause direct harm on humans, thus making the MRI a safe medical treatment. Consequently, it is a viable solution to imaging of internal body tissue.

Devices on the Market

Currently there are a number of RF coil manufacturers that have developed coils specifically designed to image extremities such as the knee. These coils are designed for compatibility with the major MRI unit manufacturers, including General Electric, Siemens, and Philips. Some of the companies that manufacture these coils are Invivo,

Toshiba, USA Instruments, Philips, General Electric, and FONAR. Examples of these devices can be seen in Figure 11 through Figure 18.



Figure 11: Large Knee Coil - Solenoidal Design.



Figure 12: 8 Channel High Resolution Knee Array – Left/Right Offsets and Pivot Rotation for Positioning and Comfort.



Figure 13: 8-Channel SENSE™ Knee Coil.



Figure 14: OSCAN M System Dual Phased Array RF Coils.



Figure 15: Signal Plus™ Knee - Circular Multi-Conductor Receiver Coil.

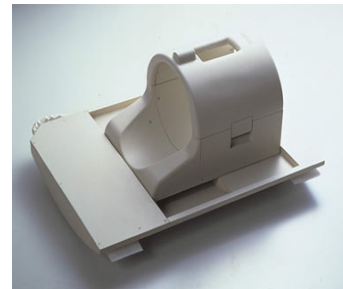

Figure 16: QD Knee Coil - Quadrature Coil, Transmit/Receive.



Figure 17: The Leo III Transmit/Receive Knee Coil - Birdcage, Split-Top Design, 2-Channel, Quadrature Design.



Figure 18: Legend 5000 Phased Array Knee – Quadrature, Coil Mechanically Split into Two Halves.

These devices range from two to eight channels and are composed of a base unit with an attached, yet adjustable, solid ring or split-top design for the coil. The split-top design requires a quadrature coil setup constructed using two independent coils. This is sometimes coupled with a birdcage design usually employing between 8 and 16 elements connected between annular rings. These two types of coils yield improved signal to noise ratio over a standard linear coil. The split-top design also aids in positioning the patients appendage in the coil. The common means of stabilizing the appendage in the coil is through the use of contoured foam support padding.

Human Geometry and Injury Considerations

MIL-STD-1472D, seen in Table 1, is a military standard for human dimensions. These dimensions are considered to be the “Human Engineering Design Criteria” for military applications and projects.

Table 1: Miscellaneous Dimensions.

<i>Miscellaneous Dimensions</i>						
<i>Region of Interest</i>	<i>Nominal Male (in.)</i>	<i>Sigma</i>	<i>Nominal Female (in.)</i>	<i>Sigma</i>	<i>Male</i>	<i>Female</i>
<i>Waist Size</i>	<i>32.35</i>	<i>3.31</i>	<i>28.15</i>	<i>2.89</i>	<i>0.472</i>	<i>0.438</i>
<i>Knee (top)</i>	<i>20.90</i>	<i>1.34</i>	<i>18.95</i>	<i>1.06</i>	<i>0.305</i>	<i>0.295</i>
<i>Hip Size</i>	<i>37.80</i>	<i>2.61</i>	<i>37.75</i>	<i>2.46</i>	<i>0.551</i>	<i>0.588</i>
<i>Trunk Circumference</i>	<i>64.80</i>	<i>3.34</i>	<i>60.75</i>	<i>2.89</i>	<i>0.945</i>	<i>0.946</i>
<i>Upper Thigh Circ.</i>	<i>22.00</i>	<i>1.88</i>	<i>22.30</i>	<i>1.88</i>	<i>0.321</i>	<i>0.347</i>
<i>Mid Calf Circ.</i>	<i>14.30</i>	<i>1.16</i>	<i>13.70</i>	<i>1.03</i>	<i>0.208</i>	<i>0.213</i>
<i>Ankle Circ.</i>	<i>8.75</i>	<i>0.70</i>	<i>8.30</i>	<i>0.55</i>	<i>0.128</i>	<i>0.129</i>

(Case)

We created a model based on both the human dimensions above and the average human criteria, as can be seen in Figure 19. The model leg was useful in showing how the design interacts with a human specimen before we produce an actual prototype. This would be the model that would be used throughout the entire project.

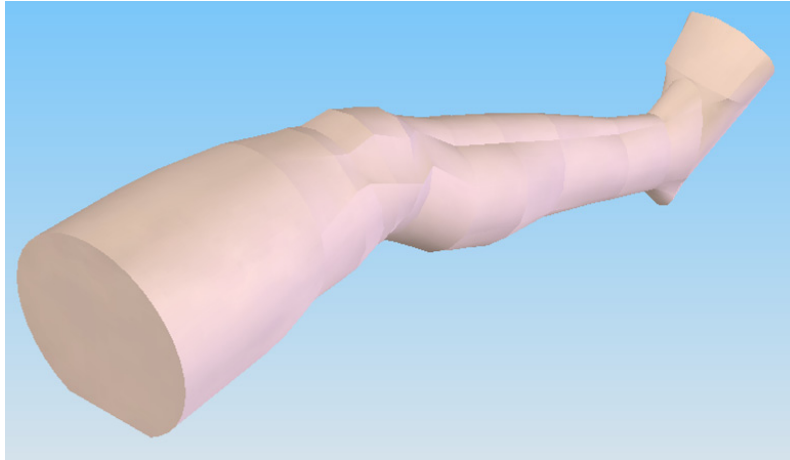

Figure 19: Human Leg Modeled after Specified Human Geometry.

Methodology

The following chart, seen in Figure 20, is a detailed flow model of the methods used to obtain our project goals. There were several instances of iteration in our methodology that allowed us to evolve our design into a practical prototype. In most cases an iteration, or change in our initial design, was due to an unforeseen fabrication complication such as the inability to machine certain geometries. Before we finalized our SolidWorks model, we extensively analyzed each part and analyzed how it would be machined and fixtured to either the manual mill, lathe, or CNC machines. From these finalized part files, we generated engineering drawings to aid in the fabrication process.

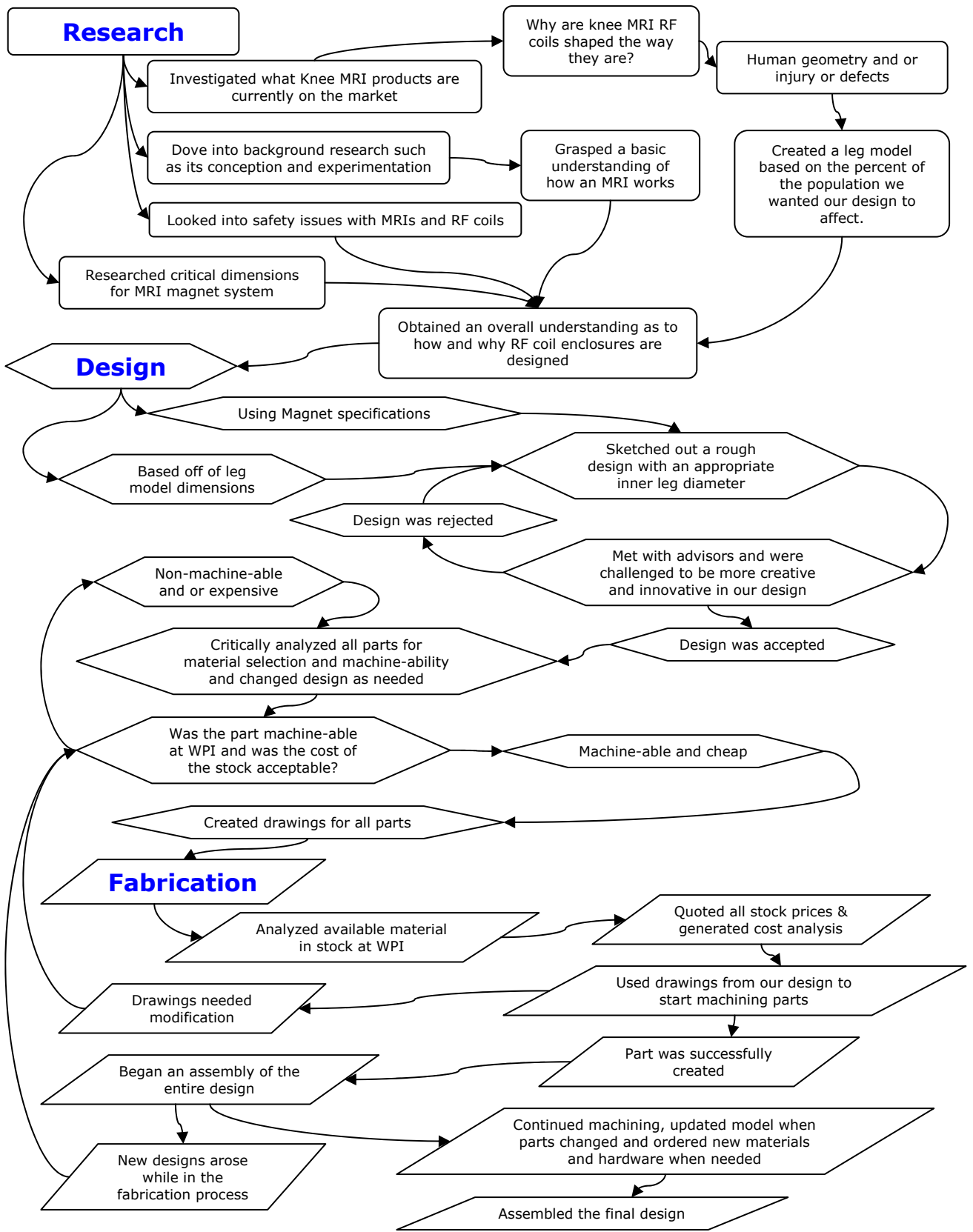

Figure 20: Project Methodology Flow Chart.

Task Specifications

The following were a set of specifications that we followed when creating our preliminary designs:

1. Ensure comfort of patient during procedure
2. Permit adjustment of the coil within the MRI machine (on the patient table)
3. Materials must be magnetically transparent (are not ferromagnetic and do not affect image quality)
4. Position and stabilize the patient's appendage within the RF coil
5. Allow for a range of appendage sizes that will accommodate a majority of patients
6. Allow adjustments to change the flexure of the knee joint (set a range of motion)
7. It should be easy for the patient to insert appendage into the RF cradle.
8. Make the coil holder light enough for a single, average person to carry (OSHA requirement)
9. Should be able to attach to a standard MRI system's table
10. Any adjustments should not be complicated and not require any more than a few steps to complete.
11. Restraints should not apply excessive pressure to the appendage
12. Coil holder should function in several MRI manufacturers units
13. Electronics should be accounted for in the design of the enclosure as well as be properly ventilated

Preliminary Design Concepts

After the task specifications were established, we developed a preliminary design that would serve as the starting point for product evolution. Various strengths and weaknesses were discovered through each design process. In the end there were four main design concepts and variations. Each of the designs included features that were the basis for the final design.

Design A – Circular Surface Coils in a U-Holder:

Our preliminary design concept covered the essentials of what was needed for a coil enclosure. Design A was drafted with a dual circular RF coil geometry. One weakness in this coil design was that it was not contoured to the leg. We later discovered that these coils would create more distortion in imaging than larger coils that spanned a longer portion of the leg.

This model did, however, provide a pathway to mechanical aspects in later revisions and design concepts. This design featured solid construction and the ability to provide spacing for the electronics in the underside of the base. Both of these design features made an impact on future designs and were core requirements for the finalized design.

Design A also included a few preliminary considerations for medical application. For the most part, anyone who used a knee coil would have an injured knee or would have suffered an injury in the past. This design allowed for the knee to be easily lifted about 12 inches and then placed into a contoured holder. Furthermore, the “open-sided” design allowed for easy access of biopsy needles. Overall, this first concept was a good combination of strengths and weaknesses that furthered later stages of development.

Some standard views of the model of views of Design A can be seen in Figure 21 through Figure 24Error! Reference source not found..

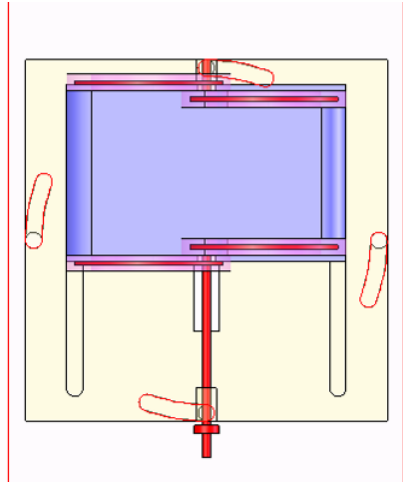

Figure 21: Top View of Circular Coils in Design A.

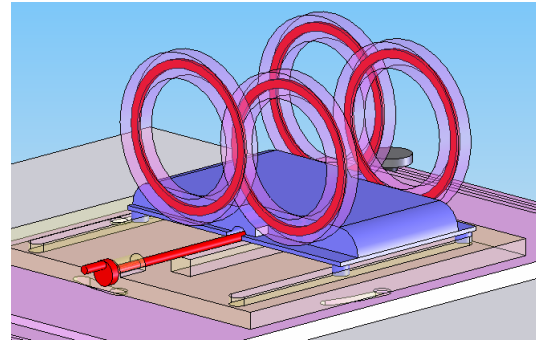

Figure 22: Isometric View of Circular Coils in Design A.

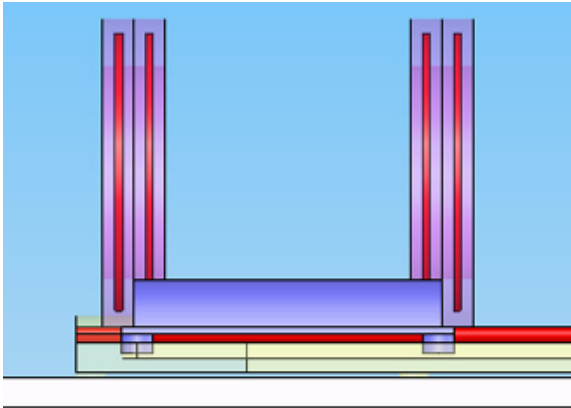

Figure 23: Front View of Circular Coils in Design A.

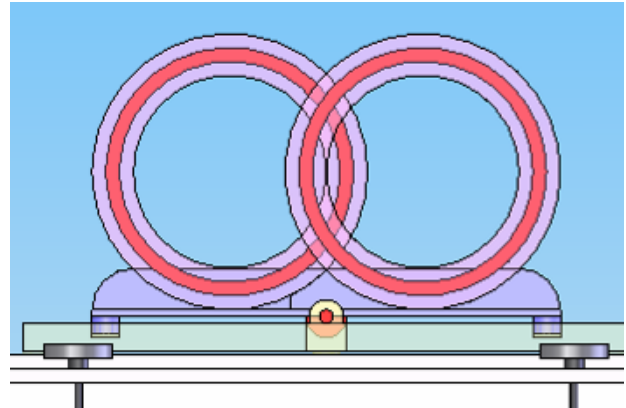

Figure 24: Side View of Circular Coils in Design A.

Design B – Saddle Coils in a U-Holder

Design B was a variation of several knee coils on the market. It featured an open air design as well as modified coil geometry. This design was similar to the standard 4 channel saddle coils produced by Phillips. The strengths were based on this design's simplicity and durability.

Design B featured a more accommodating coil design than those commercially available. The "saddle" coils were slightly curved so that the coils can be physically closer to knee. Also, the coils spanned above and below the knee to reduce image distortion due to body mass on the opposite side of the coil imaging area. Both of these adaptations made the RF coil in this design more viable than the original concept design. A weakness of the RF coil in this design was the ability to integrate a third and fourth channel. A possible consideration was integrating a butterfly coil on each side and in between the larger saddle coils, in hopes to increase image quality. Even with a butterfly coil design, it still left imaging from the top or bottom of the knee out of this design.

In terms of build quality and design for manufacturability, design B had slight advantages over the original concept. This design features the same rigid body construction as initially constructed as well as a simplistic nature that streamlines the manufacturing of it through mold-injection processes. It allows for simplistic breakdown into individual pieces for machining and assembling. Overall, the simplistic nature of the fabrication steps of this design was a major strength.

For medical concerns, this design featured the same advantages as the initial concept. The open-sided nature allowed for easy placement of an injured knee and

application of biopsy needles for further testing. The knee would also be supported by an ergonomic padding system to ensure comfort and proper placement between the RF coils.

There are many similar models on the market that utilize this exact coil design. Also, this leaves the coils in a fixed position and does not offer the ability to image from different angles. The lack of versatility of this design forced further design iteration. Some standard views of the model of Design B can be seen in Figure 25 through Figure 28.

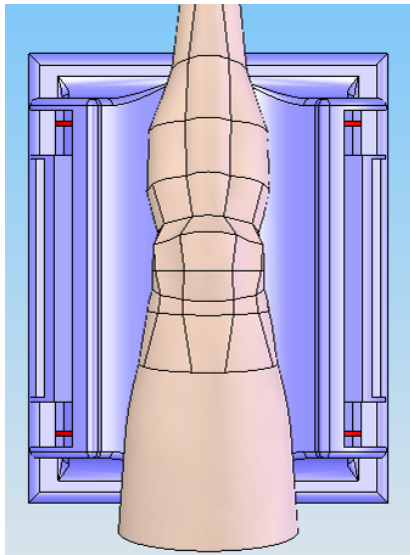

Figure 25: Top View of Saddle Coils in Design B.

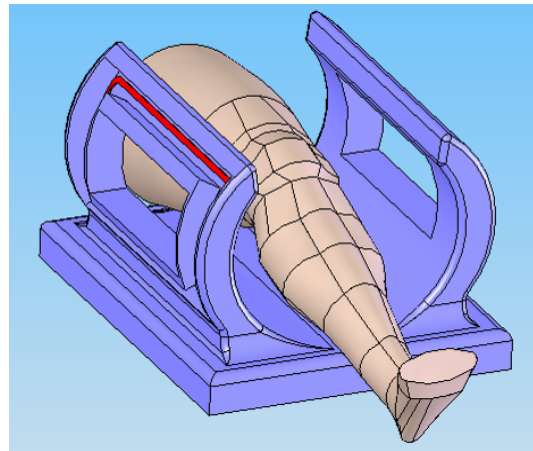

Figure 26: Isometric View Saddle Coils in Design B

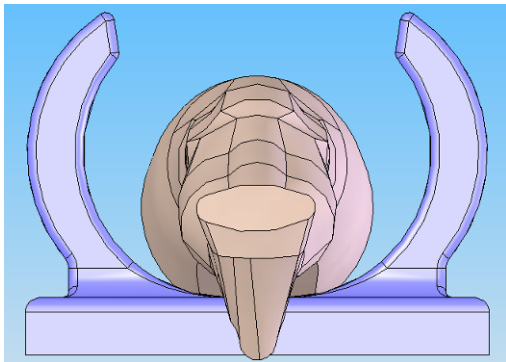

Figure 27: Front View Saddle Coils in Design B.

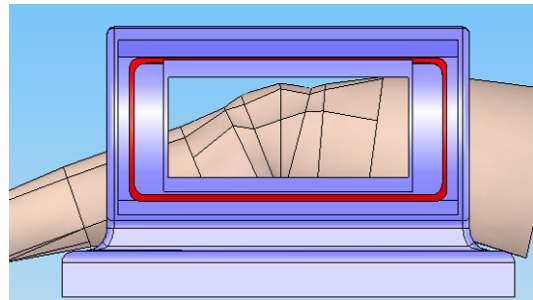

Figure 28: Side View Saddle Coils in Design B

Design C – Saddle Coils in U-Holder with Top Door

Design C featured a very similar core coil design to Design B with improved simplicity to reduce complications during fabrication. This design had a hinged upper coil housing that would allow for imaging on top as well as the sides of the knee. The coil design for this design featured the same larger spanning coils as the previous designs with the possibility of several smaller sight specific coils to increase image quality in targeted areas.

The build quality of this design would also have been just as durable as design B. The only complicating factor would have been the hinges, the attachment of the door and the accommodation of the shielded cable running from the RF coil to the electronics. Once again the simplified design would have made manufacturing and assembly relatively easy.

The open air design was kept because it accommodated for certain medical aspects such as biopsies and comfort. The hinge was placed on the top in order to add an extra coil and at the same time allow for the same comfort and ease of use as designs A and B. The ability to take a biopsy was slightly hindered because of the top coil, but there was still the opportunity of needle insertion through the windows in each set of the side coils.

Design C was just a further developed model of the designs A and B, which took into consideration a few more imaging aspects. The simplicity of the design provided for ease of use and ease of manufacturability. Also, the coil placement still limited the availability of unconstrained coil placement for versatile imaging. These shortcomings

led us to our final preliminary design. Some standard views of the model of views of Design C can be seen in Figure 29 through Figure 32.

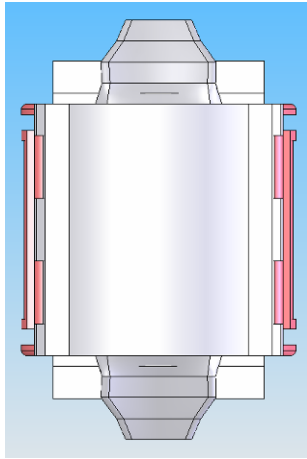

Figure 29: Top View of U-Holder in Design C.

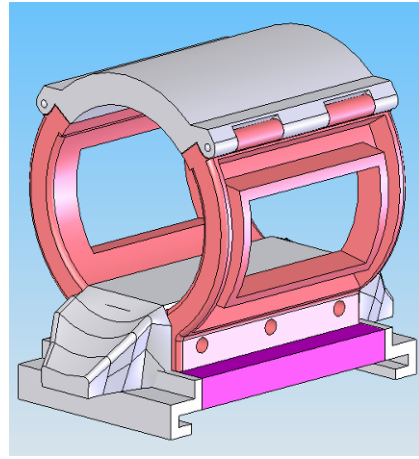

Figure 30: Isometric View of U-Holder in Design C.

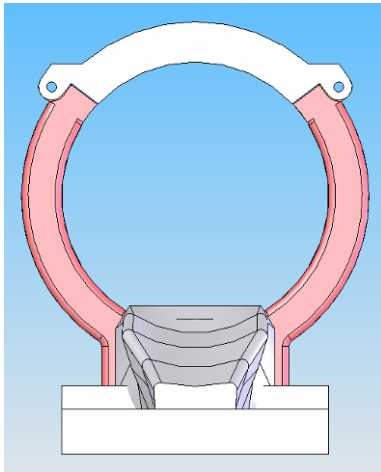

Figure 31: Front View of U-Holder in Design C.

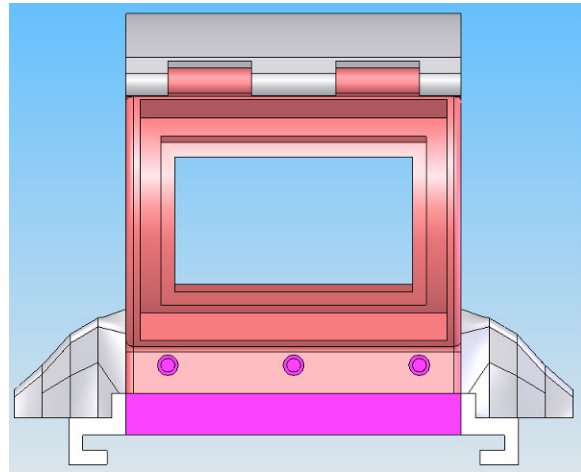

Figure 32: Side View of U-Holder in Design C.

Design D – Variable-Position Rotating Saddle Coil

Design D placed the RF coils in concaved sub enclosures that are on tracks, allowing them to be rotated to virtually any position within the inner radius of the design. The coils incorporated the larger saddle coils that increased image resolution and reduced noise as well as accommodated a butterfly coil system. The rotation of this design allowed for the coils to be manipulated in any position to truly isolate an injury.

This model was a more elaborate design than previous iterations. Each part was designed and then redesigned for easy manufacturing in the Worcester Polytechnic Institute machine shops. There were however, more parts in this assembly. This would have made the fabrication process more complicated than the previous designs. All parts were designed to be held in place with nylon screws. Mechanically, this design would have had little binding stress on the pins that guided the coil plates.

This design also accommodated the medical concerns of this project. The entire coil opened up to allow patients easy placement of a knee into the coil. Design D also would have enabled medical operators to use the coil on either leg by adjusting the coil to two fixed positions on the bottom base clamp mechanism. The true improvement in this design over products that were on the market was in its ability to image 360 degrees around the knee. This feature would have enabled medical technicians to utilize multiple positioning locations and effectively isolate and image the injured section of the knee. Some standard views of the model of views of Design D can be seen in Figure 33 through Figure 36.

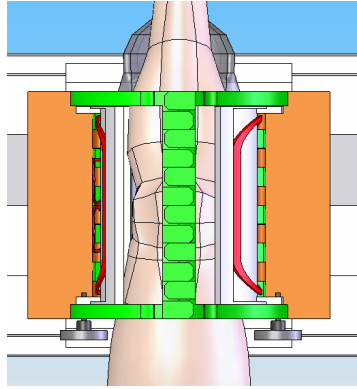

Figure 33: Top View of Variable-Position Rotating Saddle Coil in Design D.

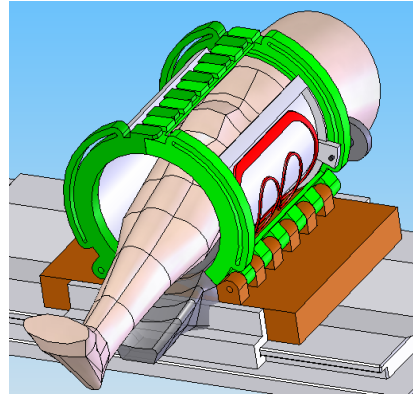

Figure 34: Top View of Top View of Variable-Position Rotating Saddle Coil in Design D.

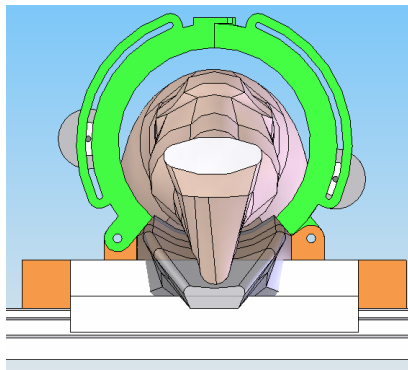

Figure 35: Top View of Top View of Variable-Position Rotating Saddle Coil in Design D.

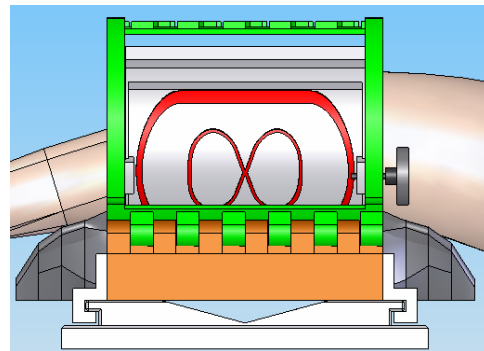

Figure 36: Top View of Top View of Variable-Position Rotating Saddle Coil in Design D.

Final Design

Consistent with standard design practices, we generated a decision matrix to effectively evaluate each model. In the matrix, we ranked five categories that were critical for a successful final product. A weighting factor was applied to the individual categories since there were certain characteristics that impact the overall design more than others, Table 2. MR image quality had the highest ranking since the desired outcome of this project is to develop a coil system that produces high resolution images of an appendage. To this effect, a large coil system and the short viewing depth were less

desirable traits. The second highest ranked categories were the ability to machine the necessary parts and machine cost. These categories were tied together by budgetary restrictions as well as limitations of the machining facilities. In an attempt to reduce cost, we were looking to fabricate parts from smaller, cheaper stock using the facility and tools freely available to us. Larger, more complex parts that required processes unavailable to us were resulted in a lower ranking for that design. Adaptability was ranked third since a multi-purpose device would be more cost effective to a consumer allowing them the possibility to image a variety of appendages. Ergonomics was the last category because all designs required the same general standards for patient comfort and accessibility. From this matrix format, each design was ranked on a scale from 1 to 5 with the highest ranked design constituting the final design, Design D with a rank of 3.60.

Table 2: Decision Matrix for the Final Product Design.

	Low Cost		Ergonomics		Adaptability		Machinability		Projected Image Quality		RANK of 5.00
Weighting Factor	0.20		0.10		0.15		0.20		0.35		1.00
Design A	7	0.70	7	0.70	2	0.20	3	0.30	2	0.20	2.10
Design B	7	0.70	7	0.70	2	0.20	3	0.30	1	0.10	2.00
Design C	5	0.50	7	0.70	2	0.20	8	0.80	4	0.40	2.60
Design D	4	0.40	9	0.90	8	0.80	6	0.60	9	0.90	3.60

General Model Configuration

Design D is shown in Figure 37. It was examined to see what improvements were required to ensure complete functionality. Any enhancements had to retain the

movable arm approach using a dual movable coil holder system while continuing to meet our functional and design constraints.

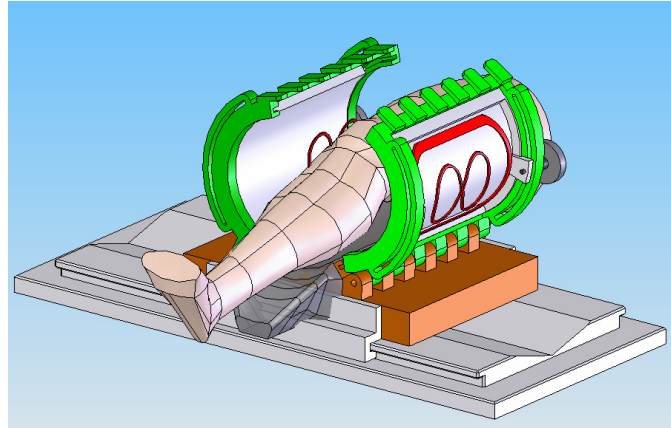

Figure 37: Design D.

After some research, we determined that the inner coil diameter should be large enough to accommodate the model of the average human leg at about 7.0 inches. Relying on data from MIL-STD-1472D, which is a military standard for human dimensions entitled “Human Engineering Design Criteria,” shown in Table 3, we initially chose an outer diameter for the enclosure arms to be 14 inches. We also chose an arm thickness of 1.25 inches to maintain the strength and durability of the arms since they will be manipulated frequently. Even with the arm thickness decreasing the inner diameter, there was a clearance of several inches around the leg to support patients with inflammation, injuries, or malformations.

Table 3: Human Engineering Dimensions.

Miscellaneous Dimensions						
<i>Region of Interest</i>	<i>Nominal Male (in.)</i>	<i>Sigma</i>	<i>Nominal Female (in.)</i>	<i>Sigma</i>	<i>Male</i>	<i>Female</i>
<i>Waist Size</i>	32.35	3.31	28.15	2.89	0.472	0.438
<i>Hip Size</i>	37.80	2.61	37.75	2.46	0.551	0.588
<i>Trunk Circumference</i>	64.80	3.34	60.75	2.89	0.945	0.946
<i>Upper Thigh Circ.</i>	22.00	1.88	22.30	1.88	0.321	0.347
<i>Mid Calf Circ.</i>	14.30	1.16	13.70	1.03	0.208	0.213
<i>Ankle Circ.</i>	8.75	0.70	8.30	0.55	0.128	0.129

(Case)

Although an 18” diameter could accommodate over 99.9% of the adult population, several commercial systems, such as Philips and Siemens, had restrictive bore diameters. As a result, we reduced the outer diameter of the arms to 12 inches to ensure that the entire assembly would fit. The 12 inch final design can be seen positioned inside a MRI magnet system, modeled after the Philips and Siemens magnet systems, in Figure 38. This outer arm diameter resulted in an inner diameter of 9.7 inches after reducing the arm thickness down to 1.15 inches. This size compromise still allowed 99% of the population to be imaged ranging from small children to adults with a maximum thigh diameter of 8.5 inches.

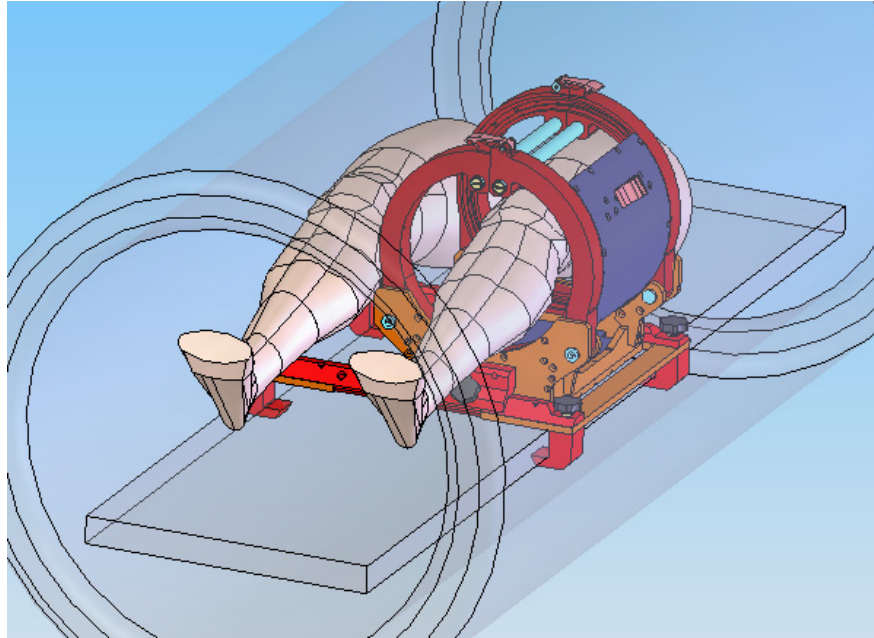

Figure 38: Isometric View of the Final CAD Modeled RF Coil Enclosure with Legs.

Once we fit both legs into the MRI model we determined how much space was available for a base unit which would support the arms of our enclosure. At the same time, we also had to consider that the base would need to slide into two positions in order to accommodate both legs once the unit is locked onto the table. Using the models of the MRI magnet and legs along with sketches of the inner and outer diameters of the arms, we found that a base position of 3.375 inches from the center plane of the table and an arm concentricity about a point 7.75 inches above the table top allowed our enclosure to be at the farthest left or right of the patient, seen in Figure 39. These dimensions offer the patient the maximum amount of room to lie comfortably in the magnet.

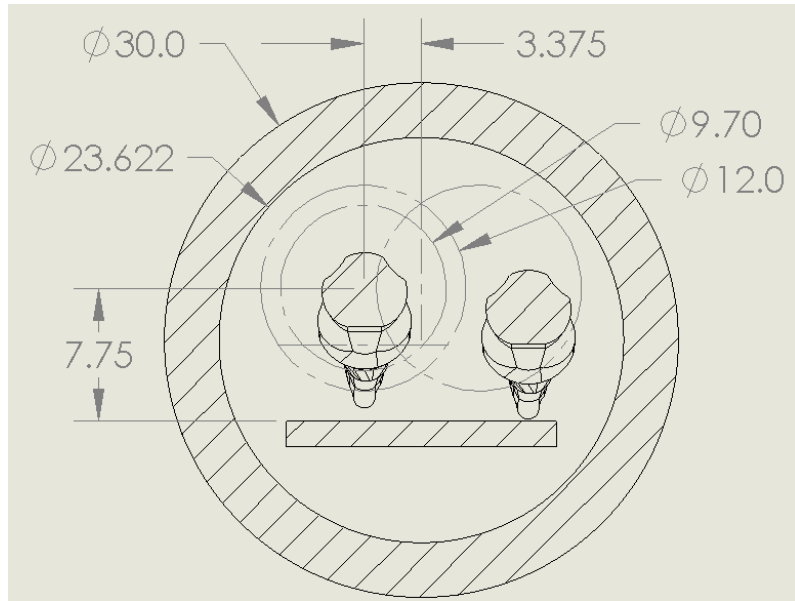

Figure 39: Position of the Legs Magnet with 12 inch Outer Diameter Arms.

From here, we used the leg models to determine the size of the rotating coil holders. Based on the experience of our advisors, we created a coil holder model that would allow the saddle coil contained within it to have the maximum coverage of the knee and surrounding areas of the leg that may also be injured. Using the arm diameters previously chosen, we found that a coil holder built with a frame of 3/8 inch material, having a width of 8.625 inches and an arc of 90 degrees for an inner diameter of 9.75 inches, yielded the greatest viewing area of the knee, shown in Figure 40.

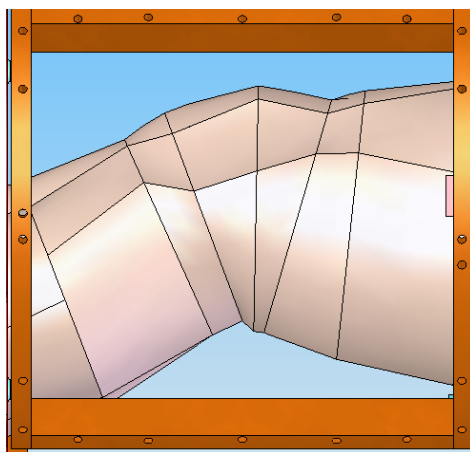

Figure 40: View of the Knee through the Coil Holder Frame.

Using these initial dimensions, we were able to create models for the four subassemblies taken from Design D: (2X) rotating coil holder, (2X) arm rail system, base, and table clamp rail system. Except for the arm rail system and table clamp rail system, we designed the product using thin-walled construction consisting of sheet Delrin and polycarbonate. To accommodate for these thin walled assemblies 3/4 inch #10 nylon flat head screws secured all the parts together. For larger parts or subassemblies that would experience forces that could shear these smaller screws, we incorporated lathed polycarbonate and Delrin pins and 1.0 inch M8x1.25 nylon flat head screws, Figure 41.

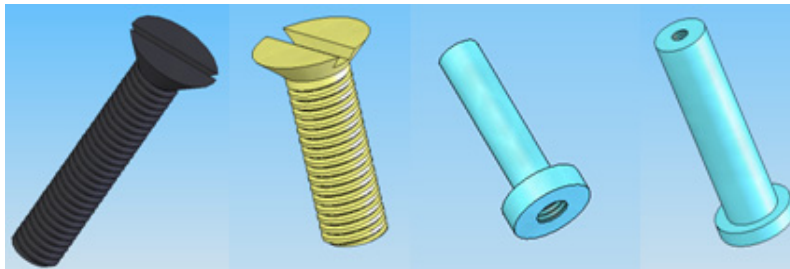

Figure 41: Models of the Screws and Pins - #10, M8x1.25, and Two Arm Pins, Respectively.

Sheet stock thicknesses of 3/8 inch Delrin were sufficient for the structural integrity of our application. Sheet thicknesses of 1/16 and 1/8 inches were flexed over stronger frames for the coil holders and base.

Rotating Coil Holder

When building the coil holders, we considered several functions that were important to the operability of the design. The most important considerations were the working envelope for the electronics and the durability of the coil holders. As mentioned, the frame for the coil holders was designed with 3/8 inch Delrin, which added enough strength and allowed a working envelope that can be visualized in Figure 42. The inner and outer covers were made of 1/16 and 1/8 inch polycarbonate, respectively. After

testing the two thicknesses on a 10 inch radius cylinder, we found that the 1/8 polycarbonate could more easily be wrapped around an outside radius than an inner radius. We chose the 1/16 inch poly for the inside because this test concerned us that the 1/8 sheet would destroy the nylon screws used to fasten it to the coil holder frame.

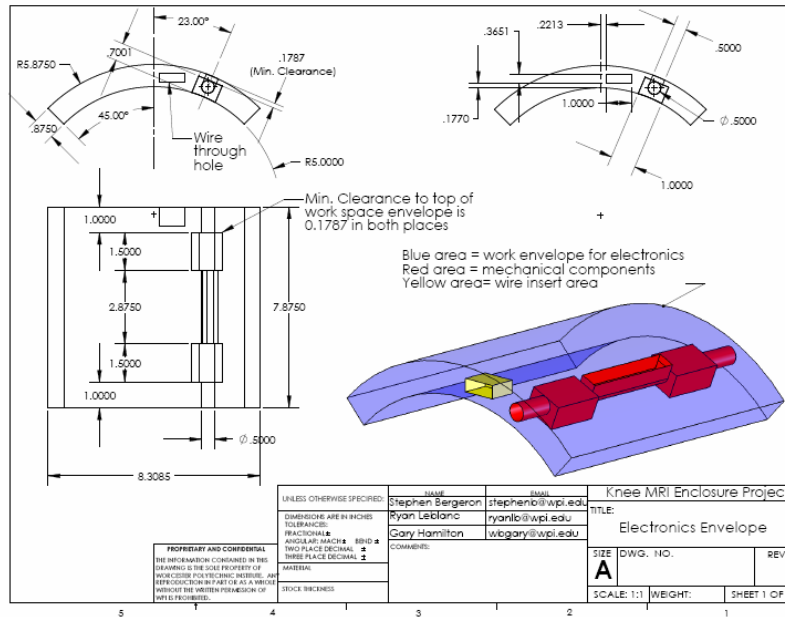

Figure 42: Electronics Envelope in the Coil Holders

Another consideration was that the design required a locking mechanism to maintain a set position of the coil holders in the arms during imaging. We designed the locking mechanism using a set of finger tabs connected to 1/4 inch pins. Each pin travels 0.35 inches to seat into holes located in the arms. The pin mechanism, seen in Figure 43, was offset to one end of the of the coil holder and is fastened to the outer cover to maintain a larger electronics envelope, seen in Figure 44. To hold the pins straight, we used slider blocks in conjunction with holes located in the side arcs of the frame. The clearance between the slider blocks and the inner cover is approximately 0.2 inches.

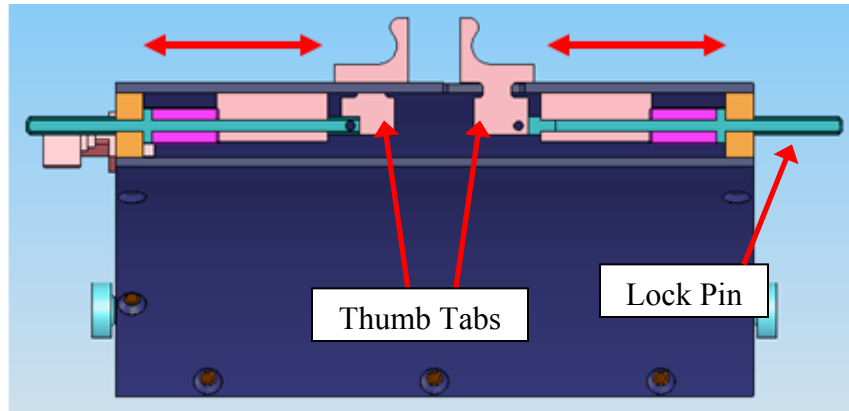

Figure 43: Coil Holder Pin Locking Mechanism

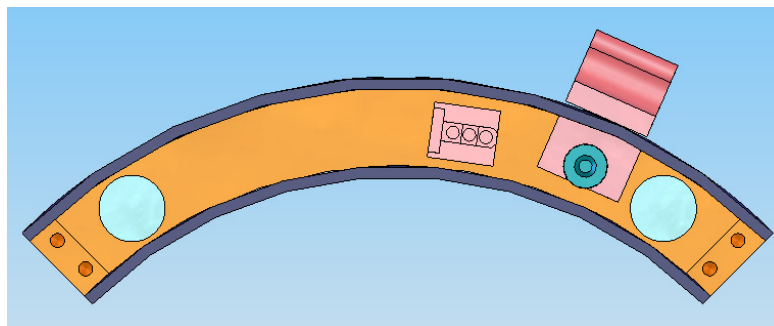

Figure 44: Radial Location of the Pin Locking Mechanism

The final considerations for the coil holder design were to create an opening for the coaxial power cables to exit the side of the holder and add bearing surfaces that could ride in the arm rails. The path we created for the three coaxial cables passed through a wire guide located in a slot in the side arcs of the coil holder frame, seen in Figure 45. The wire holes are 0.1695 inches in diameter. The stepped feature allows the cables to bend over each other, while the flat square feature prevents the cable from shifting past the coil holder as it moves around the arm rails. In order to support the coil holder in the arm rails, we created four Delrin stand-off bushings per coil holder with a bearing surface diameter of 0.75 inches to ride in the rails and a tight fit peg of 0.375 inches that fits into holes at the four corners of the coil holder, seen in Figure 46 and Figure 47. An isometric

and exploded view of the rotating coil holder sub assembly can be seen in Figure 47 and Figure 48 with a Bill of Materials and balloon callouts to identify components.

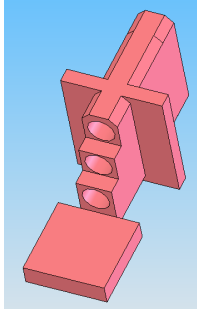

Figure 45: Wire Guide.

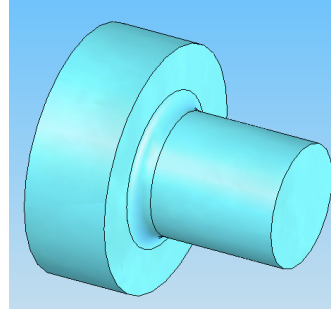

Figure 46: Stand-Off Bearing.

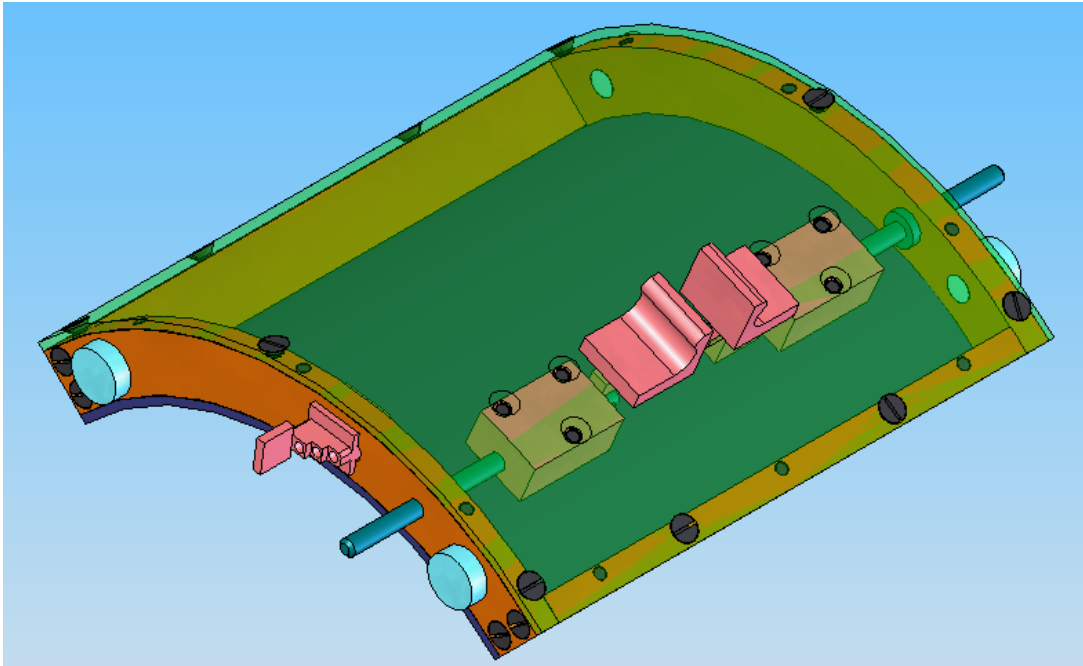

Figure 47: Final Assembly of a Single Coil Holder with Clear Outer Cover.

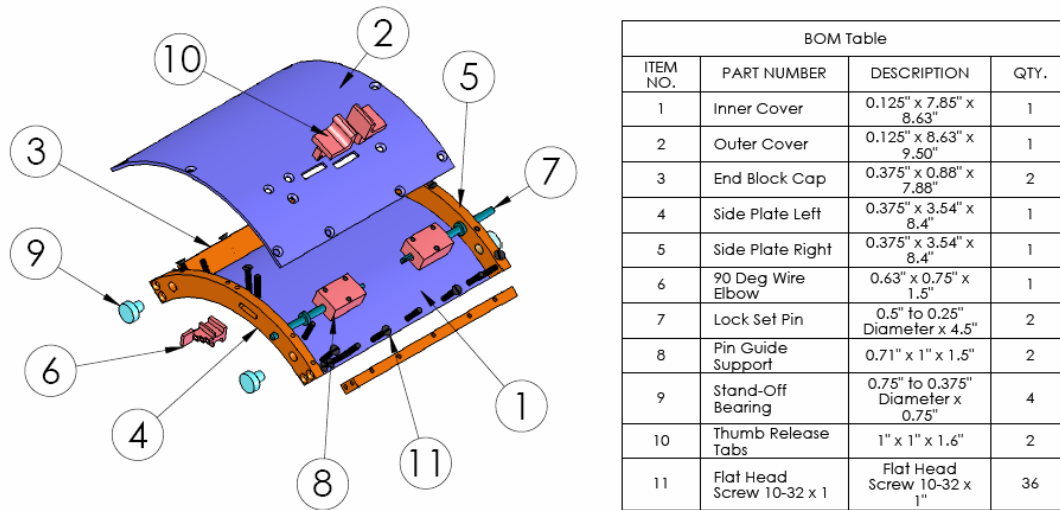

Figure 48: Exploded View of the Rotating Coil Holder Subassembly with BOM Table.

Arm Rail System

Design of the arm rail system began with the acknowledgement that certain features would be required in order to ensure acceptable functionality of the coil holders within the arms. The coil holders needed to be able to slide smoothly across the edges where the arms meet at the top and where the arms meet the base rail on the sides. The arms also had to move as one unit to prevent the coil holder from being twisted out of the track in the arms. A channel was needed to enclose the coaxial cable inside the arm so that there would be no possibility of the patient ever contacting the cable or having the cables fall out of the channel in the arms. Lastly, the arms needed features to allow the coil holders to lock into place as well as a latch mechanism to hold the arms together. The design that incorporates these requirements is seen in Figure 49.

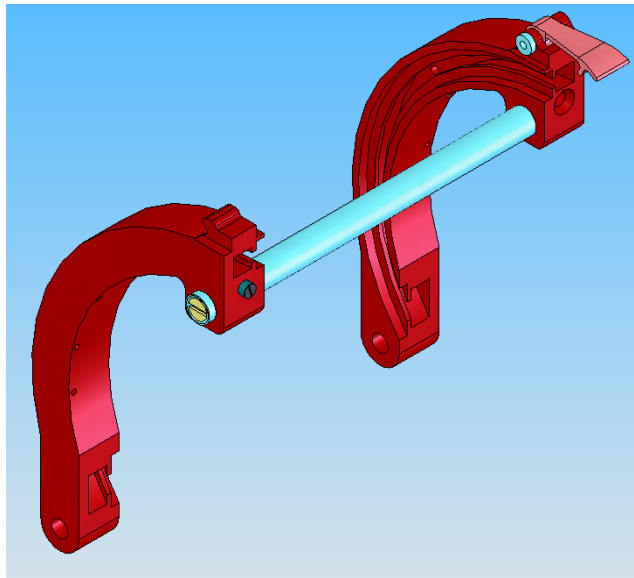

Figure 49: CAD Model of Half of the Arm Rail System.

In order to prevent misalignment of the arms, we added two separate features to the arms. The first feature was to place a peg on one arm and a chamfered hole on the opposite arm on the faces that meet when the arms are closed together, seen in Figure 50. The chamfered hole helps guide the peg into the slot and, once inserted yields a fit that accurately mates the bearing channels. Another feature is a cross-bracing rod, which connects the two arms near where they meet when closed. This rod has a diameter of 0.75 inches and is sturdy enough to keep the arms moving in unison when they are opened and closed. When closed the bars also act as a grip to carry the whole unit.

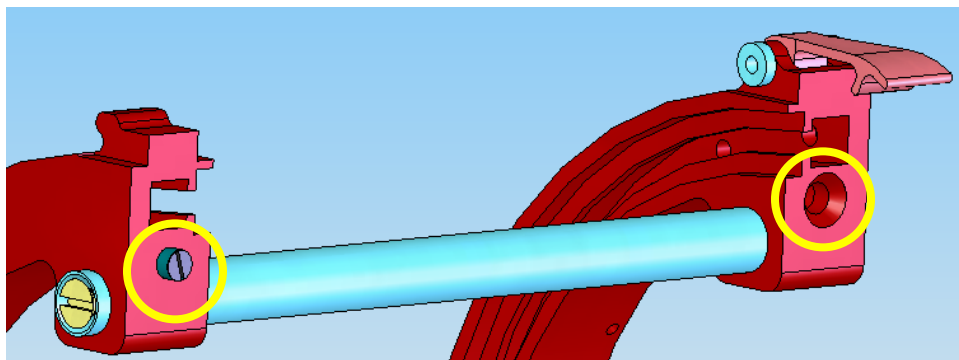

Figure 50: Peg and Hole Alignment with Cross-Bracing Rod.

The connecting piece for the upper arm assembly is fastened into the sides of the base. Like the upper arms, the base rails have indexing holes to lock the coil holders into place. These rails also have a hole that is tangential to the bottom dead center of the complete arm rail system. The hole, as seen in Figure 51, is a pathway for the cable that runs through the inner channel of the arms. When a coil holder is moved from top to bottom dead center position in the unit, the cable feeds into and out of the base through this hole. An exploded view of the arm rail subassembly can be seen in Figure 52 with a Bill of Materials and balloon callouts to identify components.

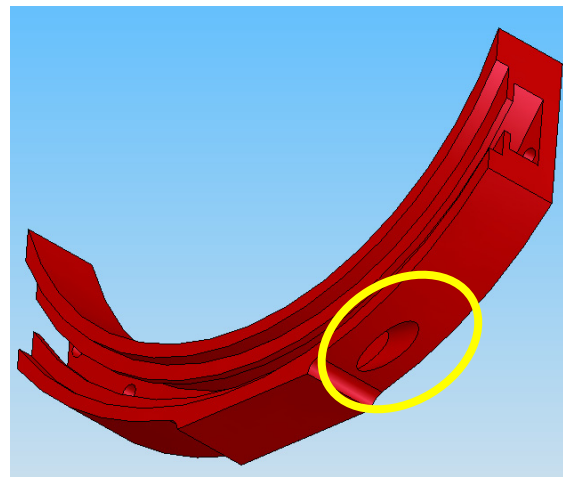
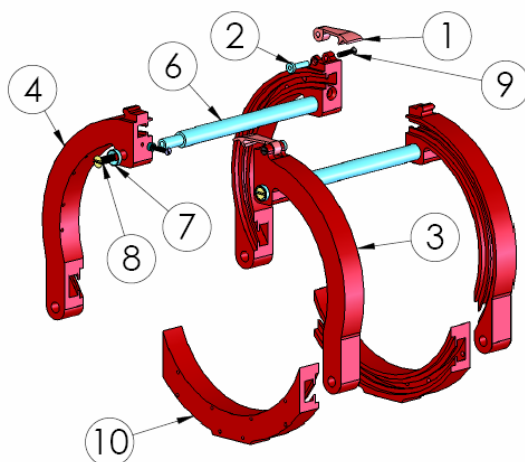

Figure 51: Lower Base Portion of the Arm System..



BOM Table			
ITEM NO.	PART NUMBER	DESCRIPTION	QTY.
1	Clamp Hook	0.62" x 1" x 2.5"	2
2	Clamp Pin	0.75" Diameter x 1.25"	2
3	Arm 1	1.25" x 6" x 11.12"	2
4	Arm 2	1.25" x 6" x 11.2"	2
5	Arm Ring	0.362" Diameter x 0.187"	2
6	Brace Rod	0.75" Diameter x 11.15"	2
7	Brace Tightener	0.75" Diameter x 0.20"	4
8	Flat Head Screw M8 x 1	Flat Head Machine Screw M8 x 1"	4
9	Flat Head Screw 10-32 x 1	Flat Head Screw 10-32 x 1"	4
10	Guide Rail	1.25" x 4.3" x 9.1"	2

Figure 52: Exploded View of the Arm Rail Subassembly with BOM Table.

Base

We designed the base of the unit to address several functional needs in order to help interconnect the features of the other subassemblies. The base subassembly performs the functions of anchoring and maintaining the stability of the arm rail system and the unit as a whole, housing the electronic components as well as the cable that attaches the electronics to the coil holders, and fastening the unit to the table rail subassembly. An isometric view of the entire base subassembly can be seen in Figure 53.

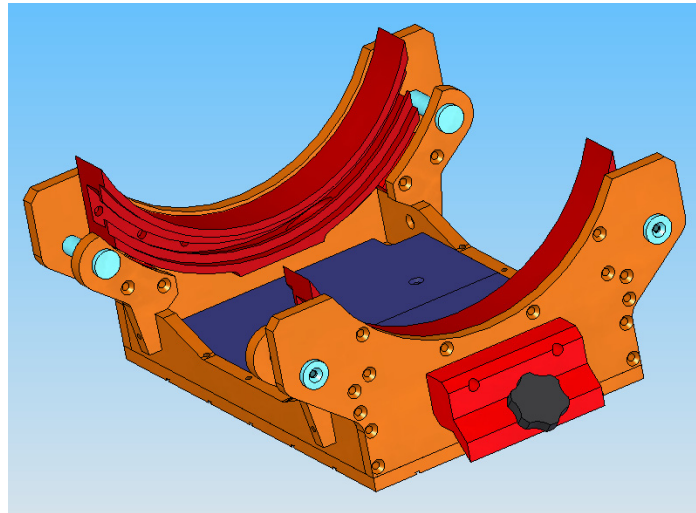

Figure 53: Isometric View of the Complete Base Subassembly Including the Base Guide Rails.

Attaching the upper arm rails to the base required anchor points at the four corners using machined pins and #10-32 nylon screws. The side coil guides in conjunction with arm supports provide a clevis to secure the arm pin to prevent any pressure on the arm from bending the pin. Arm support standoffs offset the arm supports the correct distance and help maintain the structural integrity of the support system. A view of the arm support system can be seen in Figure 54.

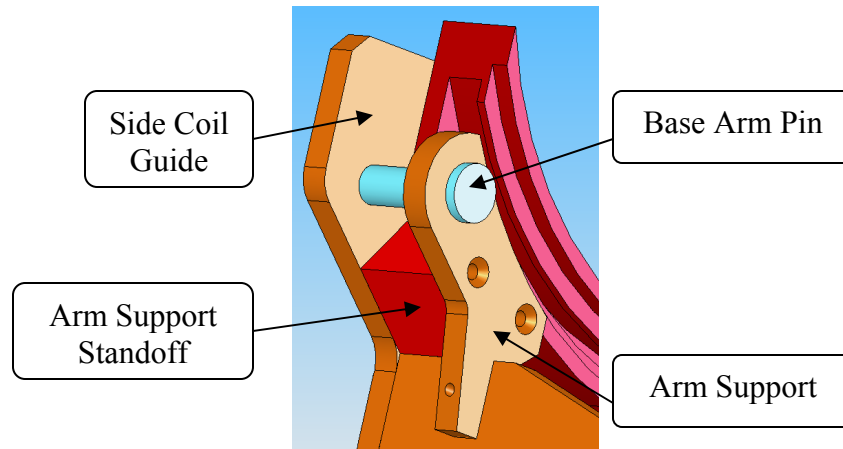

Figure 54: Upper Arm Rail System Anchor Point.

A base guide rail is attached to each side coil guide using six #10-32 nylon screws. The location of the base rail and these attachment points is shown by the yellow circles in Figure 55. This figure also shows the curved feature of the arm supports, which leaves a clearance of 1/16 inches for the coil holders.

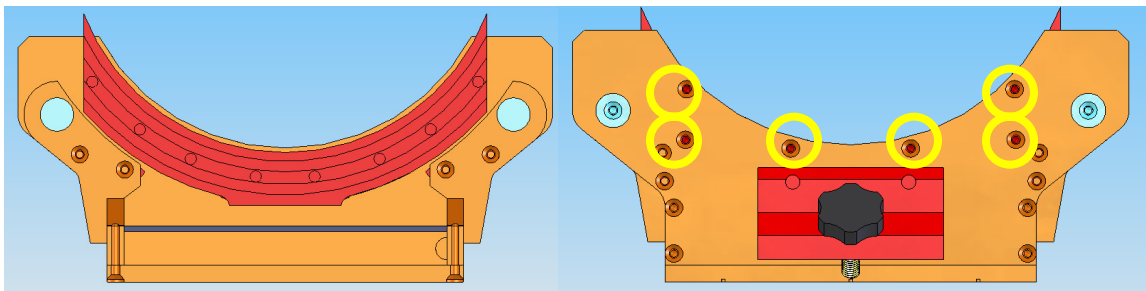

Figure 55: Lower Arm Rail Attachment to Base.

Both Figure 55 and Figure 56, respectively, include a front and side view of the thumb screw and bracket used to attach the base to the table rail system. The base bracket attaches to the side coil guides using two stronger M8x1.25 nylon screws. We also implemented these same size screws with a rosette, press-fit thumb screw head to anchor the base to the table rail. Another feature of the base, seen in Figure 56, is a lowered area on the side support. This cutout allows a medical technician to more comfortably reach

their hand into the base to lock or unlock a coil holder located at the bottom dead center position.

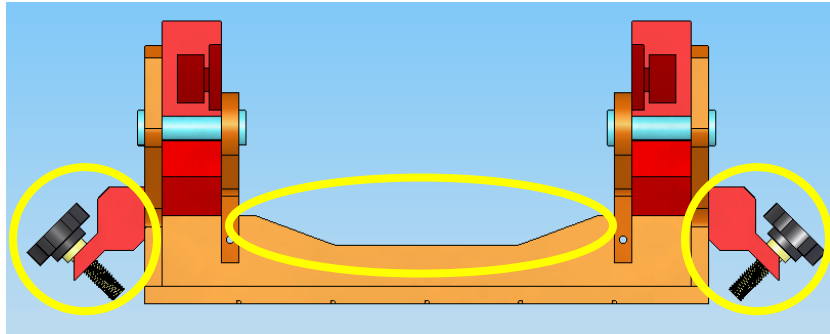

Figure 56: Side View of the Base Including the Table Rail Thumb Screws, Brackets, and Side Cutouts.

The final function of the base is to house the electronics and extra, coiled cable fed from the arm rail system. All of the electronics are retained behind 1/8 inch clear plastic as a safety precaution. The electronics components are located in the center of the base outlined by the yellow box in Figure 57. The enclosed electronics envelope is 2.25 inches x 7.25 inches x 0.75 inches. On either side of the electronics compartment are the cable compartments, outlined in magenta in Figure 57.

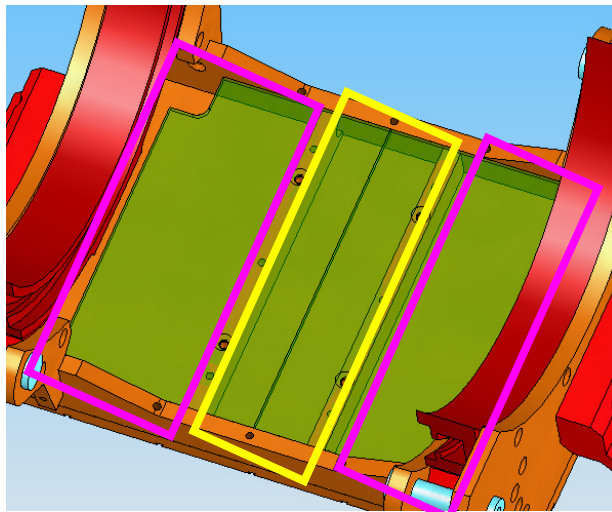

Figure 57: View of the Cable Coiling (Magenta) and Electronics Areas (Yellow).

From the electronics compartment, the cable runs through notches at either end of the wire coil dividers and into the cable compartments. In the cable compartment, the three bound cables loop once and then enter the base guide rail. As the coil holders rotate about the knee in the arm rail system, the bound cables slide along the inner rail channels and into the cable compartment. During this rotation, the cables wind and unwind to account for the slack when the coil holder is at bottom dead center. The path of the cables and the cable compartment is shown in Figure 58. Finally, an exploded isometric view of the entire base subassembly is shown in Figure 59.

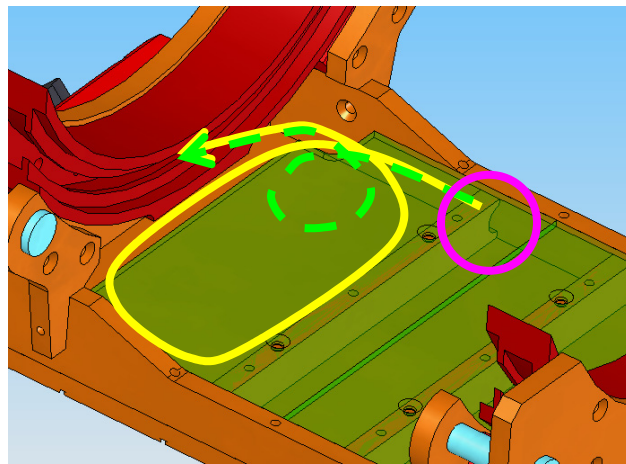
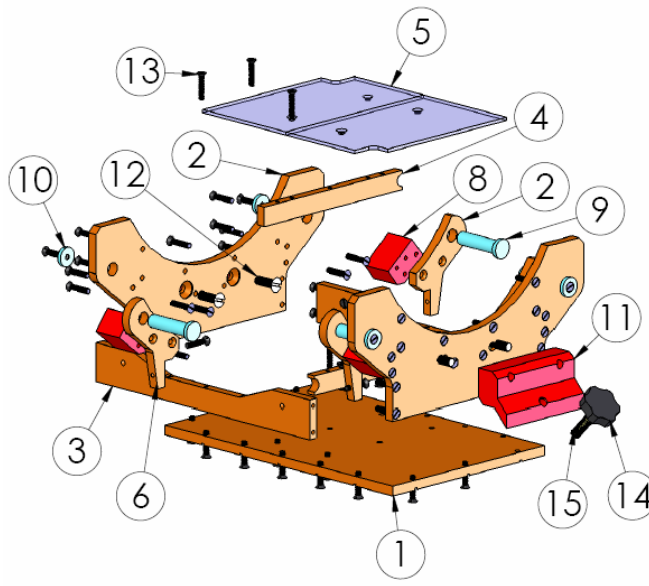

Figure 58: Cable Pathway for a Coil Holder with Maximum (Yellow) and Minimum (Green) Cable Slack.



BOM Table			
ITEM NO.	PART NUMBER	DESCRIPTION	QTY.
1	Base Plate	0.25" x 8" x 12"	1
2	Side Coil Guides	0.375" x 5.13" x 1.2"	2
3	Side Support	0.375" x 1.5" x 11.25"	2
4	Wire Coil Divider	0.375" x 0.75" x 7.25"	2
5	Electronic Cover	0.125" x 7.25" x 8.75"	1
6	Arm Support 1	0.375" x 2.6" x 3.63"	2
7	Arm Support 2	0.375" x 2.6" x 3.62"	2
8	Arm Support Standoff	1.08" x 1.25" x 1.75"	4
9	Base Arm Pin	0.75" to 0.5" Diameter x 2.15"	4
10	Base Arm Cover	0.75" Diameter x 0.15"	4
11	Base Bracket	4.0" x 1.65" x Delrin 1.5"	2
12	Flat Head Screw M8 x 1	Flat Head Machine Screw M8 x 1"	4
13	Flat Head Screw 10-32 x 1	Flat Head Screw 10-32 x 1"	78
14	Thumb Screw	1.5" Diameter x 0.6"	2
15	Socket Head Cap 0.375-16 x 1.25	Socket Head Cap 0.375-16 x 1.25	2

Figure 59: Exploded View of the Final Base Subassembly with Bill of Materials.

Table-top Base Rail System

We designed the base rail system to be a sturdy, simple structure that allows the base to sit directly on the table and lock in two set positions. An isometric view of the final design of the table-top base rail subassembly is shown in Figure 60.

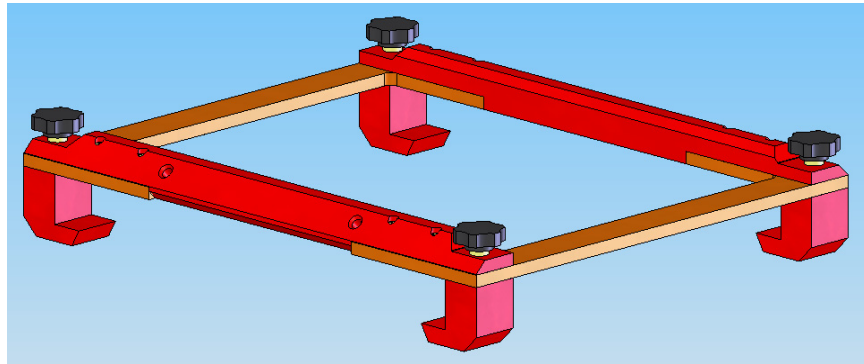

Figure 60: Final Design of the Table-top Base Rail Subassembly.

The system is composed of two parallel rails that support the base brackets from the base subassembly. The rails are machined from 1.5 inch plastic and have chamfered edges to aid in machining the base positioning holes, seen in Figure 61. The large

chamfer creates more space for manipulation of the thumb screw and acts as the surface onto which the base brackets are clamped. The base positioning holes are 3.875 inches from the center plane of the subassembly, as seen in Figure 62.

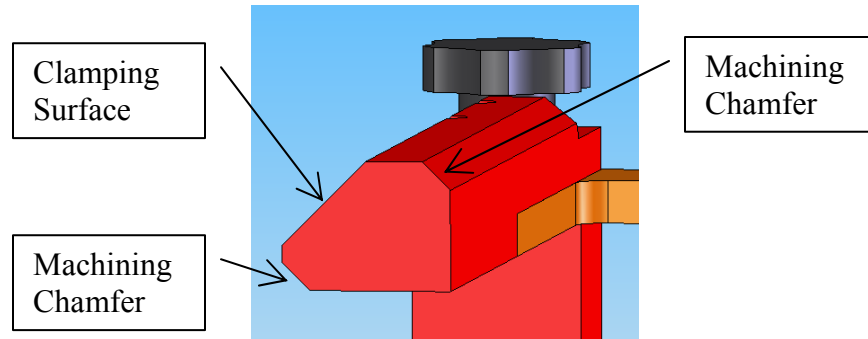

Figure 61: Beveled Edges on the Table Rail.

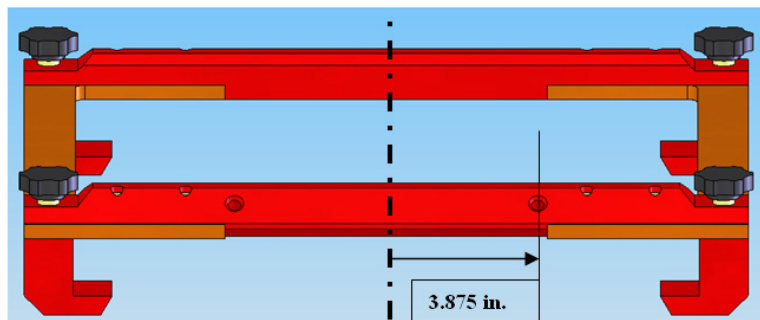

Figure 62: Lock Positions on the Table Rails.

The table rails are connected by 3/8 plastic stock shown in orange in Figure 63, which also includes an isometric view of the table-top subassembly and a bill of materials. Fasteners used in the assembly are M8x1.25 nylon screws. Four thumb screws, one at each corner, are threaded into plastic hooks to clamp the assembly onto a table. For this design, we used a table dimension of 16 inches as was average among the MRI units we researched.

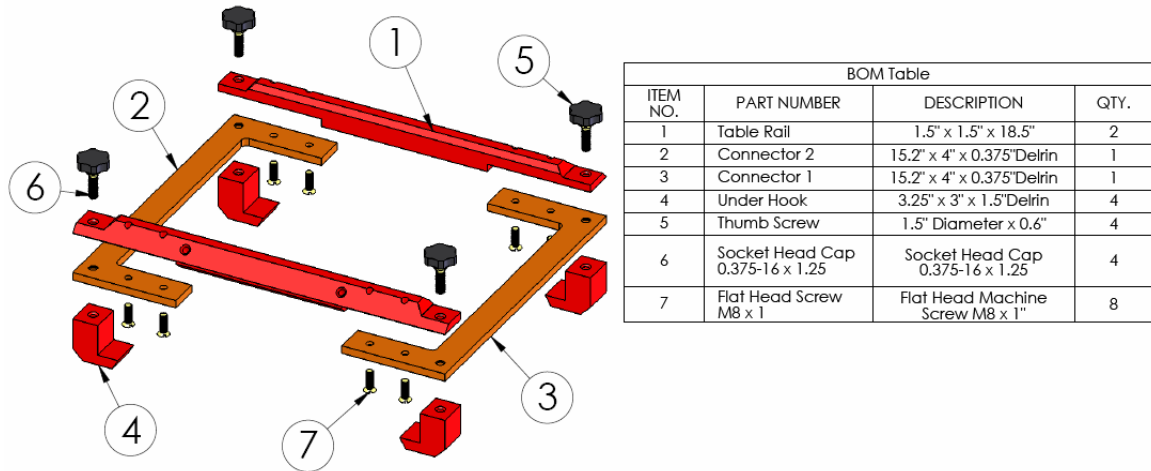

Figure 63: Exploded Isometric View of the Table-top Base Rail Subassembly including a Bill of Materials.

Materials

The material needed to be non magnetic with a low dielectric constant. Certain plastics with higher dielectric constants, while non magnetic, interfere with the quality of the MRI image. The constants for materials we considered using for our project can be found in Table 4. Delrin is a name brand acetal homopolymer that is typically an opaque white in color. We decided to fabricate the majority of our project out of this material because of its material's properties, aesthetic value, and cost. It has a dielectric constant circa 3.7 farads per meter and it has a relatively high range of temperature tolerance.

Table 4: Raw Material Comparison

Material	Dielectric Constant (Farad/m)	Advantages	Disadvantages
Delrin	3.7	Easily machined, tapped, durable, and very cost effective	Non-transparent
Polycarbonate	3.1	Transparent, and strong	Low melting point, very expensive
Nylon	3.1	Easily machined, tapped, durable for threaded structures, and very cost effective	Low melting point, non-transparent
Plexiglas	2.5	Transparent, and strong	Difficult to machine, extremely brittle, fairly expensive
Teflon	3.4	Easily machined, tapped, and very durable	Not cost effective

The material also needed to be machinable. This would mean that the material would have to be durable enough to withstand heavy milling and drilling, but also have a high enough melting point that the heat dissipation from the tooling would not melt the surface. Cost consideration was also a factor for the material selection.

Standard stock thickness for each part was selected to standardize machining. The circular arms that house the wiring and guide the coil enclosures were made out of 1.5” Delrin stock. The coil holder enclosure and smaller components were made out of 3/8” stock. The base, locking mechanism and inner base walls were made from 3/8” stock, with the exception of some parts. Some of the miscellaneous pieces were made from scrap 1.5” stock and 1.5” x 1.5” x 24” Nylon stock ordered from McMaster-Carr. The cost breakdown for each stock type and material is shown in Table 5.

Table 5: Cost Analysis

Cost Analysis Sheet	
Delrin Sheet Stock	\$636.63
Thin Clear Polycarbonate Sheet Stock	\$31.83
Nylon Stock	\$58.04
Nylon Screws, 10-32 and M-8 along with Thumb Screw Hardware	\$42.10
Total	\$768.60

Delrin was primarily used for the larger parts, while polycarbonate and nylon were used for smaller features such as pins and screws because of their high durability and low cost. We used polycarbonate “windows” on some features so that we could display the inner electronics. This allowed for visual observation of the electrical components and the inner construction features. Nylon screws were used due to their low cost and reasonable dielectric properties.

Fabrication

The main materials used for the construction of the knee RF coil were Delrin, Plexiglas (acrylic), polycarbonate, and nylon. All parts were ordered through McMaster-Carr and shipped directly to our manufacturing facility. Automated manufacturing was carried out on the HAAS VMC Vertical Spindle - Mini VMCs and manual machining was performed on manual band saws, lathes, manual mills and manual drill presses. The manufacturing plan was an iterative process of material selection, pricing, fixturing, and layout designs for further manufacturability.

The larger arms were made from 1.5” Delrin stock. To reduce the NC coding and fixturing time significantly, the arms were not split into several pieces as originally planned. Although this process increased the scrap quantity of Delrin stock, the machine and programming time justified it easily. A generalized part layout for the individual arms is shown in Figure 64. Notice that the fixture plate, shown in white, resembles a “L.” This shape was formed out of scrap material in order to be accommodated by the vice in the HAAS Mini VMCs.

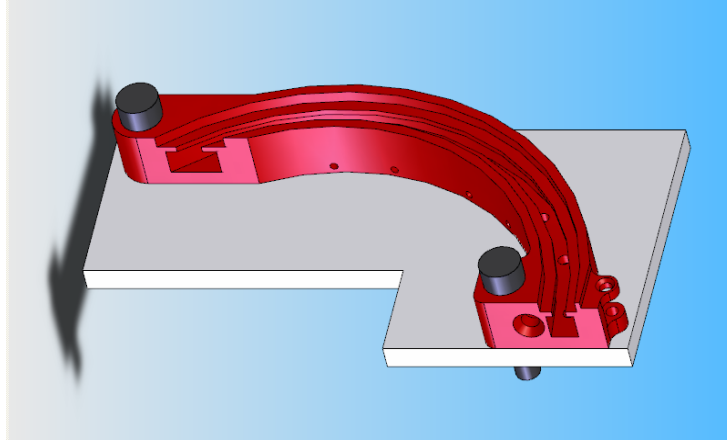

Figure 64: Fixturing Arms for CNC Machining

After the arms were fabricated, they were grouped into two separate assemblies shown in Figure 65. Each arm assembly contained two arms that were mirrors of each other, a clamping hook used to hold the pair of arm assemblies in a locked position during imaging, and a brace rod used to stabilize the arm assembly during use. The turquoise brace rod was added to the final design when we realized that the temporary upper fixturing points were going to be difficult to machine off. Instead of machining off these fixture points, we incorporated them into our design and simplified the fabrication of the arms assembly.

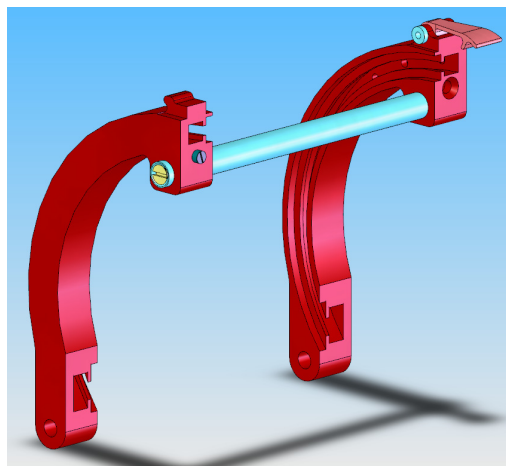

Figure 65: The Arm Assembly

The base and coil holder unit designs were simplified so that each part was formed or cut from a sheet of stock. Numerous components were simple enough so that they could be rough cut using a band saw, smoothed with a manual mill, and then drilled and tapped using the digital read out on the manual mills. These designs reduced the amount of machine time significantly. Any rods of material were also purchased and manually cut to the desired length. For the most part, these small rods were nominal in cost and did not add a large percentage to the final cost of the materials for the project.

For the base, the machined stock was assembled and screwed together using nylon 10-32 screws. When fully assembled, the 3/8 inch stock used in the base resembled the model in Figure 66. Notice that the entire model is the same color; this was done purposefully throughout the entire assembly to help distinguish between material thickness.

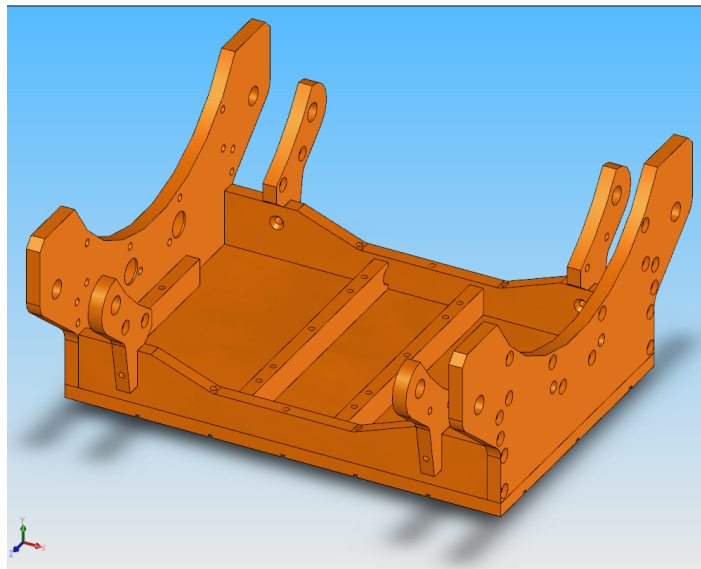

Figure 66: Spacing Plan for Base parts on 3/8" plate

The last sub-section of this assembly is the unit that physically holds the entire apparatus to the MRI table. This was designed with absolute simplicity in mind along with durable functionality. The unit composed of similar thickness material so that it

could be machined out of the same stock as the other parts. Most of the parts in this assembly were simple enough to use manual machinery. Once again, this reduced in machine set up time and allowed many of the parts to be made relatively quickly. An example of the base clamp unit can be seen in Figure 67.

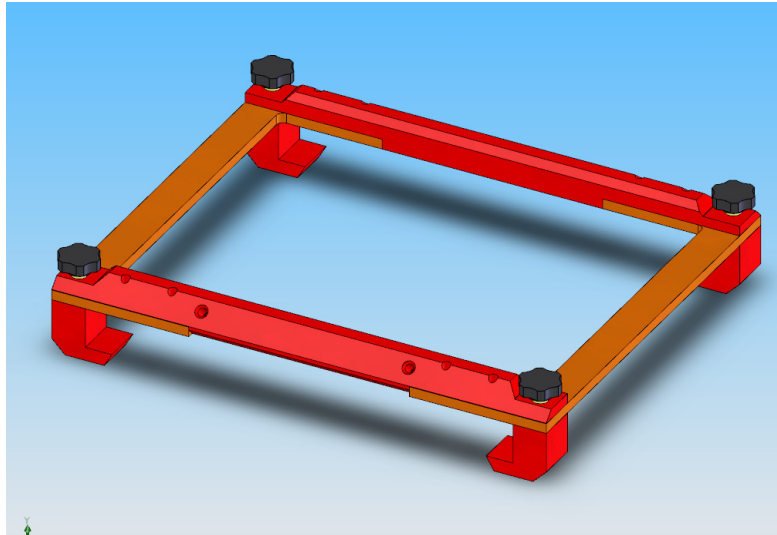

Figure 67: Base Clamp Mechanism

To help aid in organization during machining and processing, a bill of materials and parts guide was made, shown in Table 6. This inventory sheet specified assembly name, part name, quantity needed, material, a description about the raw stock, and the minimum stock thickness that was needed for each assembly. This list also served as a checklist for making sure what we had been machined and what parts needed to be fabricated. Furthermore, this list of materials helped finalize the ordering process by allowing us to compare what materials we had in stock and what materials we needed to purchase.

Table 6: Final Assembly Model Tree.

Assembly Hierarchy

Assembly Number	Part / Assembly Name	Quantity	Material
1	Base Clamp	1	
	Table Rail	2	Delrin
	Connector 2	1	Delrin
	Connector 1	1	Delrin
	Under Hook	4	Delrin
	Thumb Screw (Sub Assembly)	4	
	Thumb Screw	1	Nylon 6/10
	Socket Head Cap	1	Nylon 6/10
2	Base	1	
	Base Plate	1	Delrin
	Side Coil Guides	2	Delrin
	Side Support	2	Delrin
	Wire Coil Divider	2	Delrin
	Electronic Cover Outer Support	2	Delrin
	Electronic Cover	1	Polycarbonate
	Arm Support 1	2	Delrin
	Arm Support 2	2	Delrin
	Arm Support Standoff	4	Delrin
	Base Arm Pin	4	Delrin
	Base Arm Cover	4	Delrin
	Guide Rail	2	Delrin
	Base Bracket	2	Delrin
	Thumb Screw (Sub Assembly)	2	
		Thumb Screw	1
	Socket Head Cap	1	Nylon 6/10
3	Two Arm Assembly	2	
	Clamp Hook	1	Delrin
	Clamp Pin	1	Delrin
	Arm 1	1	Delrin
	Arm 2	1	Delrin
	Arm Ring	1	Delrin
	Brace Rod	1	Delrin
	Brace Tightener	2	Delrin
4	R.F. Coil Enclosure	2	
	Coil Holder Inner	1	Delrin
	Coil Holder Outer	1	Delrin
	Lock Pin	2	Delrin
	Push Tab	1	Delrin
	Conrod	2	Delrin
	Stand-Off Bearing	4	Delrin
	Pull Tab	1	Delrin
90 Deg Wire Elbow	1	Delrin	
5	Screws		
	Flathead Machine Screws	< 400	Nylon 6/10
	Metric Flathead Machine Screws	30	Nylon 6/10

This project required several different manufacturing techniques to reach completion. During each method of manufacturing careful attention was paid to cutting speeds and feeds to ensure the proper finishing of the plastics used during construction. In general, all the pieces that could be made on a manual mill, lathe, or drill were done on such a machine. For the more complex parts, HAAS CNC mini mills were used to machine complicated geometry. Additionally, the thin stock used as outer shells on some parts was machined using custom fixtures and clamps.

The base of the assembly was machined first. A manual milling station was used for the base components which were generally simple and square. Plexiglas was chosen for the material of the base because it is relatively easy to machine as well as cost efficient. Constructing the base out of Plexiglas also allowed for a clear base to display the inner chambers, where the electronics would be stored and the wire coiled. Most pieces were squared off and then cut to dimension using a 0.5 inch carbide end mill and a spindle speed of 1500 – 2000 RPM. All of the holes were drilled and counter-sunk on the milling machine, and then hand tapped for 10-32 screws. The four sidewalls had some complex geometry that could not be done manually. The CNC mini mills were utilized to cut the circular portions of the sidewalls of the base. A custom fixture was made to clamp the pieces into the vice. Figure 68 is a picture of the completed and assembled base.

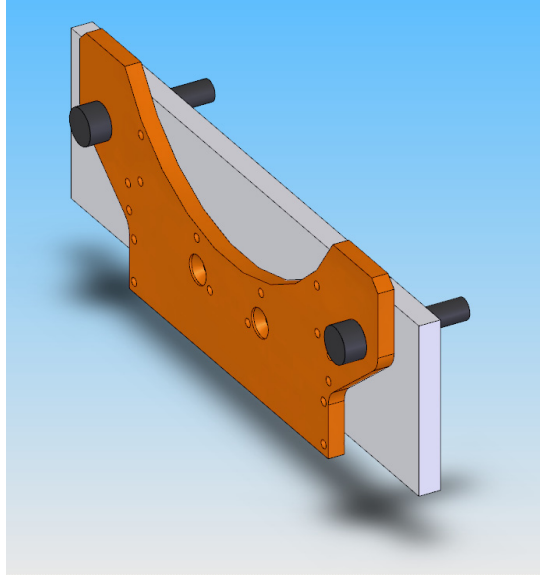

Figure 68: Fixturing Side Coil Guide for CNC Machining.

The second main subsection of this assembly was the arms. They were the most difficult and crucial parts of the assembly, thus they required the most careful planning. A special T-Slot Cutter (1/4" Bolt Size, 9/16" Cutter Diameter, 15/64") was purchased to mill out the inner channels where the wires were to be threaded through. To accommodate for the difficult and complex geometry, special fixtures were made to bolt the stock down so that they could be clamped into the CNC machine. This eliminated tool offset problems that would arise during a contour mill of the entire outer profile of the part. For parts that had no through holes that we could bolt into a custom fixture, we simply added tabs with through holes that could be manually milled off after the CNC process was complete. The machining of these parts also proved to be quite time consuming because of the 1.5 inch thickness of the original stock.

For the last main section of the assembly, the table clamp, we tried to simplify the fabrication process. Since the focus of these parts was on durable functionality this stock was also quite thick at 1.25 inches. Most of the features of the parts were done on a manual mill, with some of the curved sections being done on the Haas mills. The

simplicity of these parts helped reduce cutting time and overall time to manufacture this sub-assembly. Completed photographs of assembled sections can be seen in the results section as well as in the appendices.

Results

After the successful completion of the fabrication of the MRI RF knee coil enclosure, we conducted an evaluation of the overall accuracy of the design with respect to the final CAD model. These tests consisted of a physical manipulation of each moving part and an assessment of the quality of the fits required for best functionality. During this process we also conducted a visual inspection of the enclosure to ensure that the physical parts matched drawing specifications. All parts that required CAM techniques were verified in the GibbsCAM software package as well as the visual simulation on the Haas CNC machines. In some cases, slight modifications were made to the part geometry in an attempt to correct the errors in design assumptions. We machined all parts to the best of our abilities and were satisfied with most of the resultant system. Only one subsystem, the RF coil holders, required a major redesign, the details of which will be discussed further along in this section.

Complete Enclosure

The overall functionality of the entire project rested upon the completion of several subsystems, as discussed earlier. The parts for the base, arms, base clamp and coil holder each were machined and assembled separately to complete the project. In terms of the main goal, the entire enclosure completed the original vision of having a rotating coil

design that was not only rigid but practically designed for its application. In Figure 69, a comparison between the overall modeled assembly and the finished product can be seen.

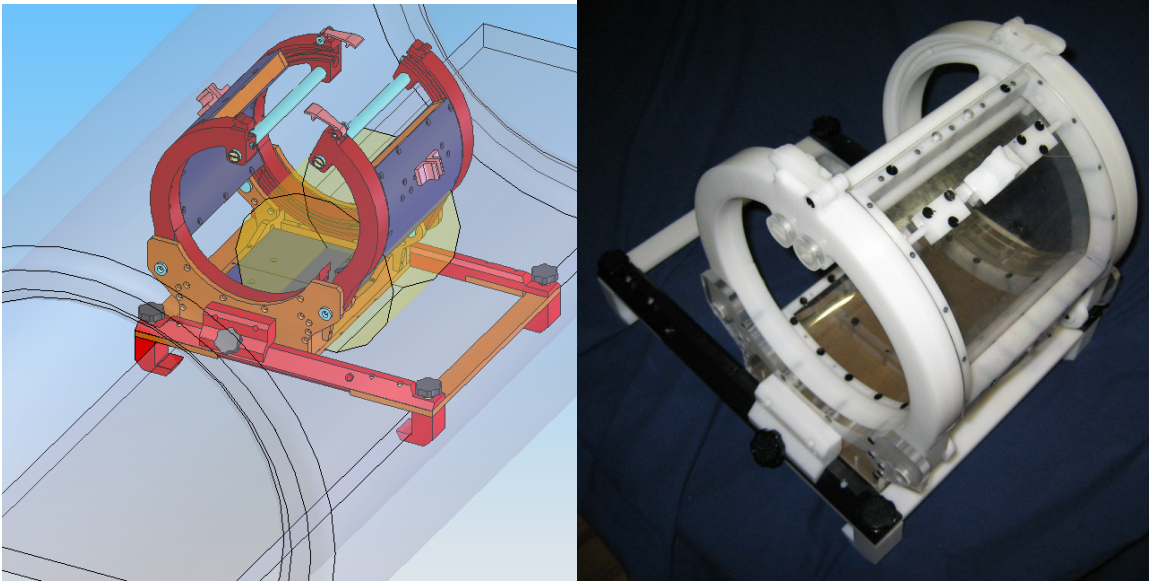

Figure 69: Comparison of CAD Modeled RF Coil Enclosure to Physical Assembly.

Further explanation of the modification and problems that occurred in the individual subsystems is located in the next few sections. From this overall design, minimal changes including proper dimensioning, design for manufacturability, and material pricing needed to be completed. These added design steps delayed manufacturing three to four weeks further than originally planned.

Base

The base was the simplest subsection and therefore it was quite easy to produce a working prototype. There are no moving parts within the base subassembly therefore no dynamic testing needed to be done with the finished parts. The only testing that was done on this subsection was tolerancing the holes to ensure a tight fit between parts that were screwed together. Also, after each part was finished being fabricated, the dimensions were checked to ensure that they were within 0.05 inches of the specified dimension in

the design. Examples of specific features of the base compared to designed models can be seen in Figure 70 through Figure 74.

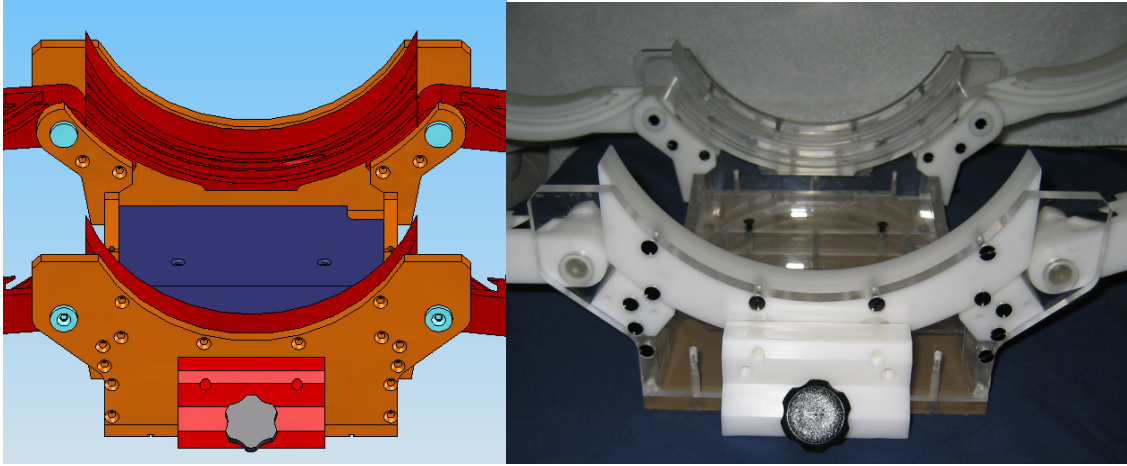

Figure 70: Overall Base Comparison.

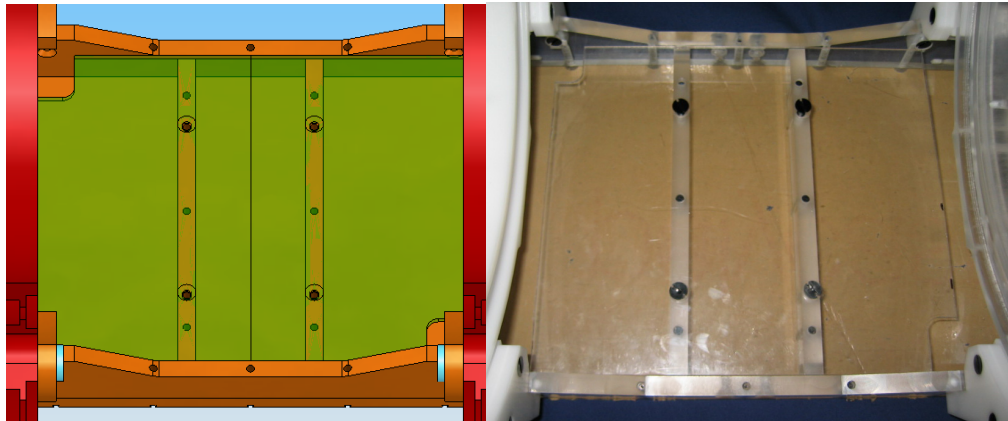

Figure 71: Electronics and Wiring Bay Comparison.

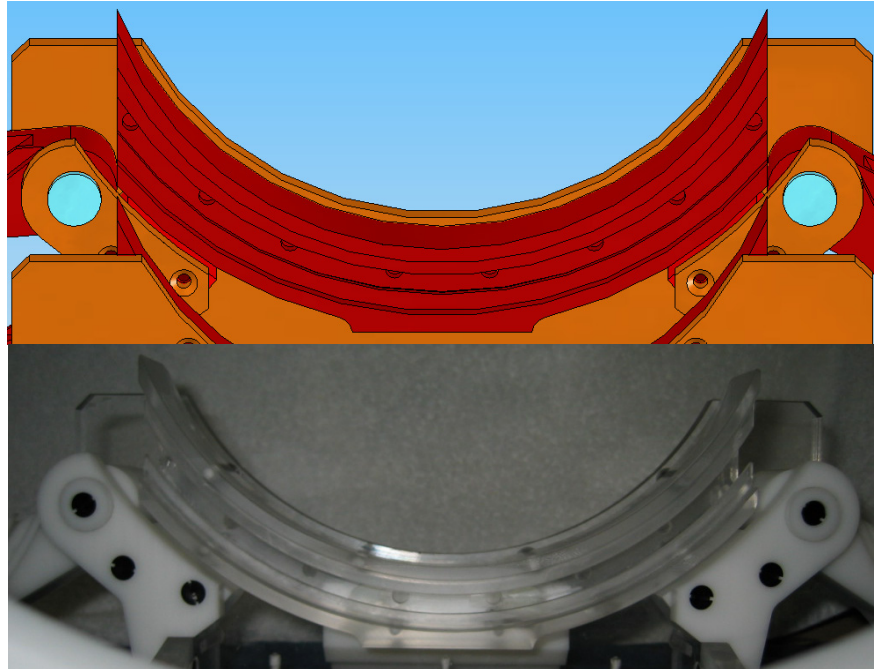

Figure 72: Base Wire Track Comparison.



Figure 73: Inner Wire Track Comparison.

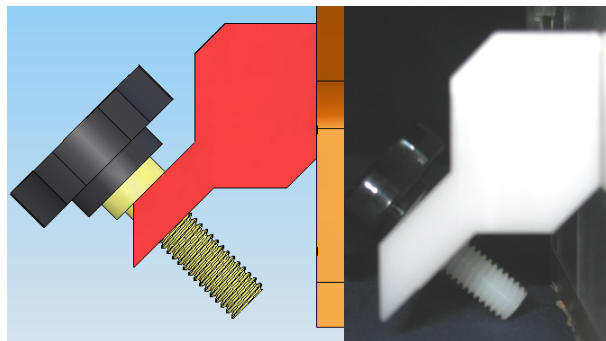

Figure 74: Base Thumb Screw Comparison.

The features of the base were constructed successfully as the designs had intended their functionality. We were able to machine each of the parts as originally planned and ran into few problems with this subsection. One minor problem came from the assembly and disassembly of the base. As the project moved forward the base needed to be taken apart several times. In doing so, some of the tapped holes became stripped out in the process. The second problem arose when we tried to machine a hole in the curved surface of the wire guide. It was quite difficult to drill the hole as designed; therefore, some geometry modification was required. The hole then needed to be sanded down to ensure the plastic tubing could slide through the hole without getting caught on the rough edges. A comparison of the designed wire guide hole to the fabricated part can be seen in Figure 75.

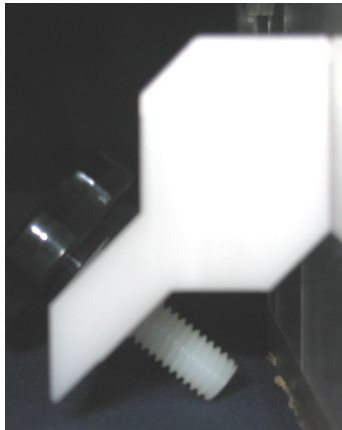

Figure 75: Wire Guide Hole Comparison.

Arms

The arms were the subsection that most accurately represented the conceptual drawings. All of the arms were fabricated using the CNC mills which ensured less error than using manual machinery. Each of the features on the arms worked without flaws during the testing and assembly period. The holes on the inner tracks were all in the

correct position and were functionally correct to line up the coil holder in the desired positions. The pins that were used to connect the arms to the base were completed with the correct tolerance so that they had a turning fit. In Figure 76 through Figure 78, there is a comparison between the drawings and the actual fabricated parts of the arm subsection.

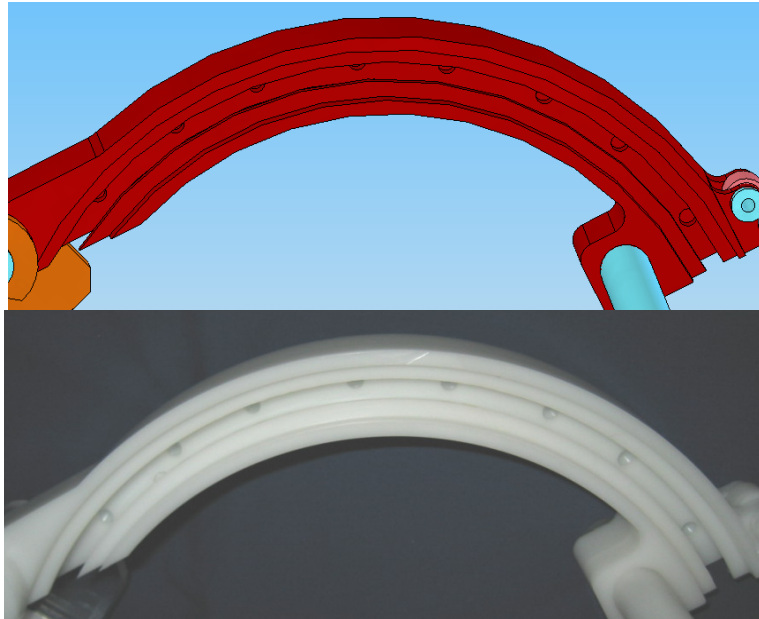

Figure 76: Arm Front View.

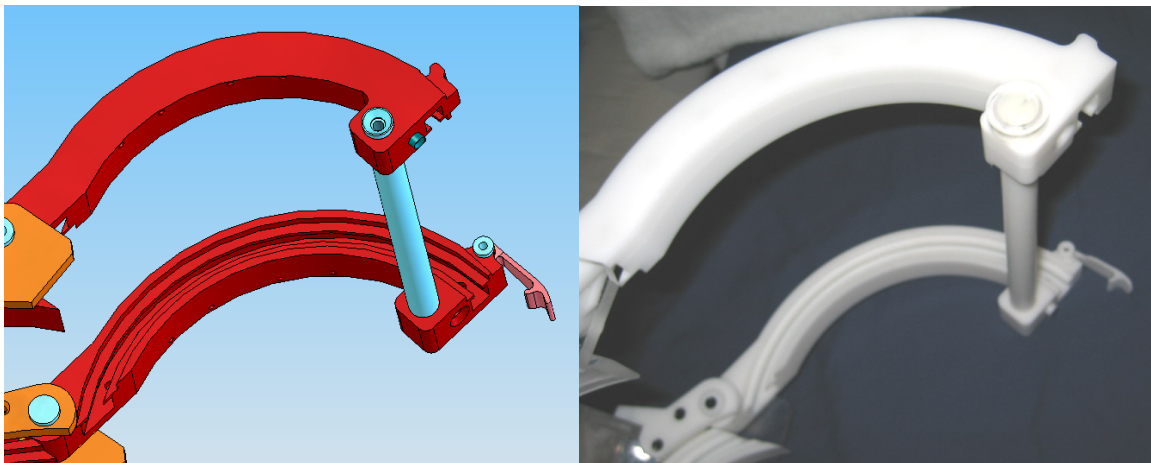

Figure 77: Isometric view of the Arm Subassembly Comparison.

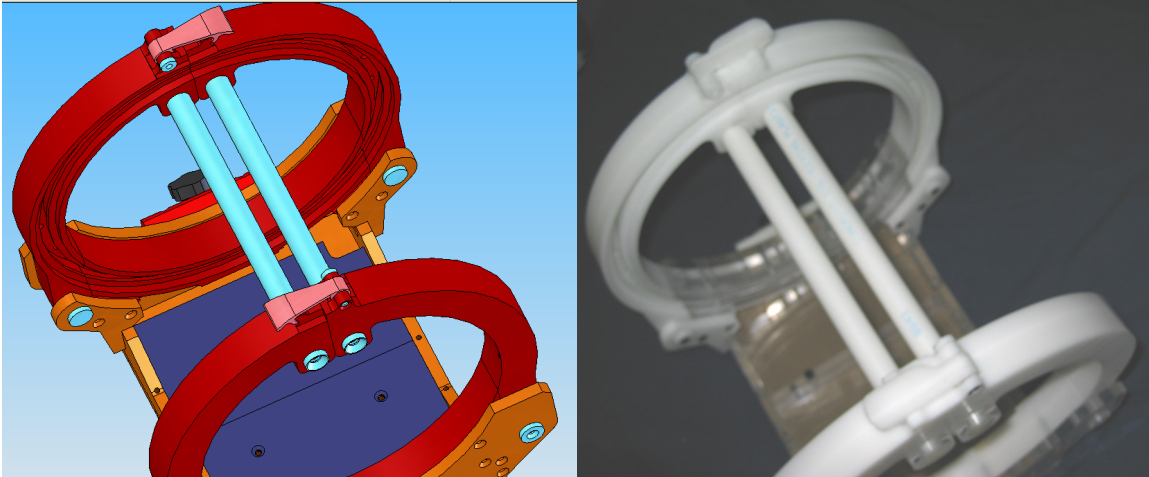

Figure 78: Full view of the Arm Subassembly Comparison.

The most important feature of the arm subassembly was the intricate track that needed to be cut into the profile of the entire arm. This allowed for proper sliding of the coil holder as well as the sliding of the wires in the inner track. Special machining considerations needed to be made during the fabrication of this feature, but completed it with accuracy. As it can be seen in Figure 79, the inner track was successful during the fabrication process.

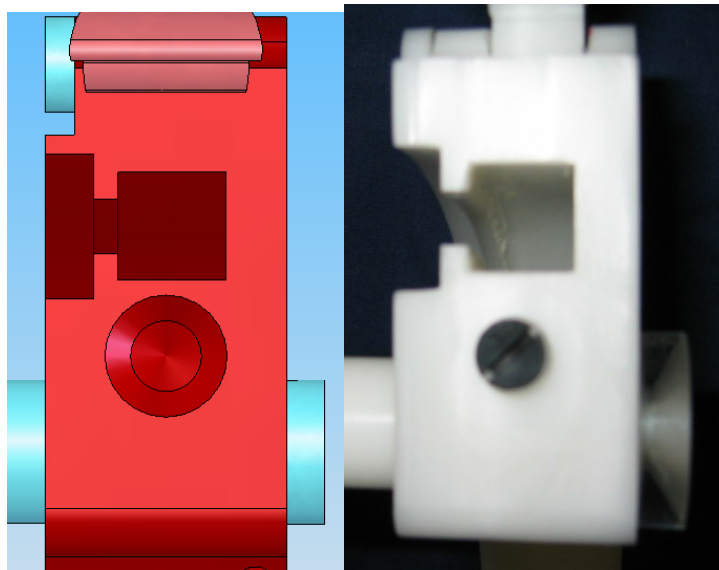

Figure 79: Inner Bearing & Guide Track Comparison.

Some minor nonfunctional problems did occur during the manufacturing process on the arms. These problems resulted in a product that was completely functional, yet did not represent the exact model. For example the latch at the top of the arms and the hook that it attached to had to be modified during fabrication to accommodate using a ¼ inch mill. This changed the geometry of the final product but not the functionality. The latch still operated as desired during the testing phase of assembly. Figure 80 and Figure 81 illustrate the comparison between the models and the fabricated parts.



Figure 80: Latch Hook Comparison.

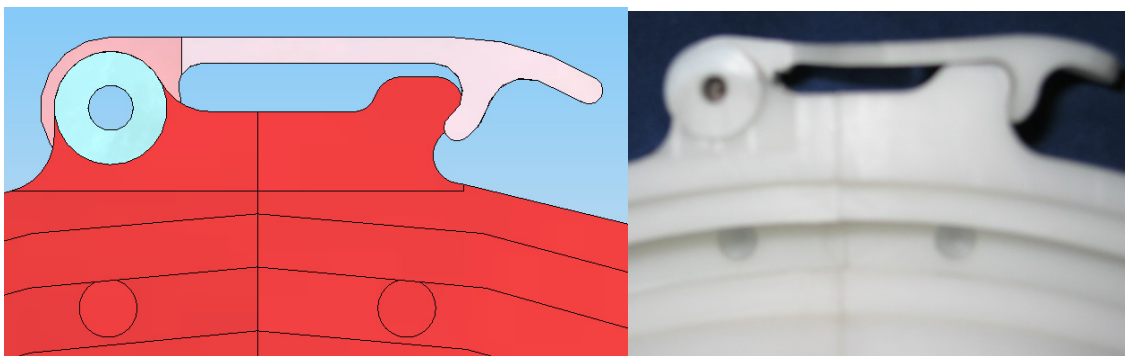

Figure 81: Functionality Comparison of Arm Latch.

The one major problem that slightly affected functionality of the arms occurred during machining of one of the large arms. The fixture that held the stock into the CNC mill was not properly in place during machining. The resulting part was about 0.05 inches

shorter than it needed to be. A small gap was left in between the arm and the base. When this was tested with the coil holders in place, it did not however affect the rotation of the coil holders. Figure 14 displays the resulting gap from the machining error:

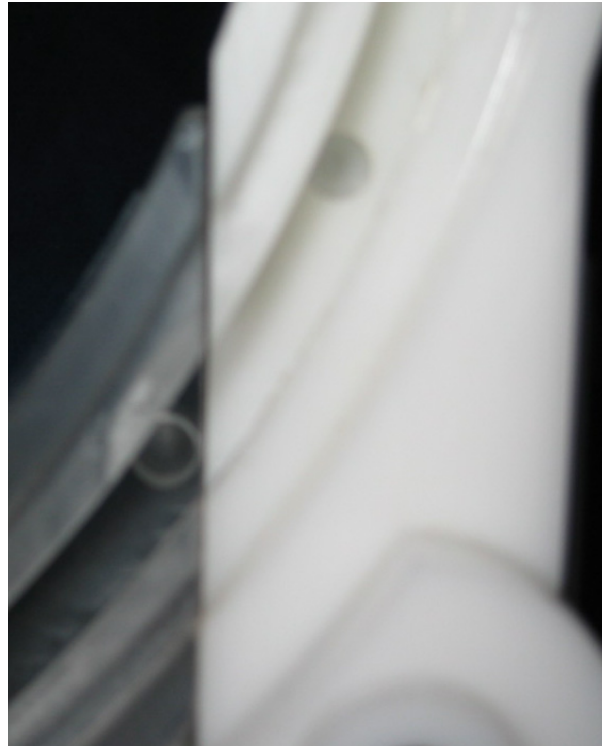

Figure 82: Arm Machining Error.

Base Clamp

The base clamp subassembly was also created with accuracy to the detailed designs. Since most of the parts were machined manually, they had simple features that were easily fabricated. During testing the base slid over the base clamp just as desired. The holes were correctly placed to ensure that both legs would comfortably fit in the assembly. Figure 83 displays the base clamp as compared to the designed models.

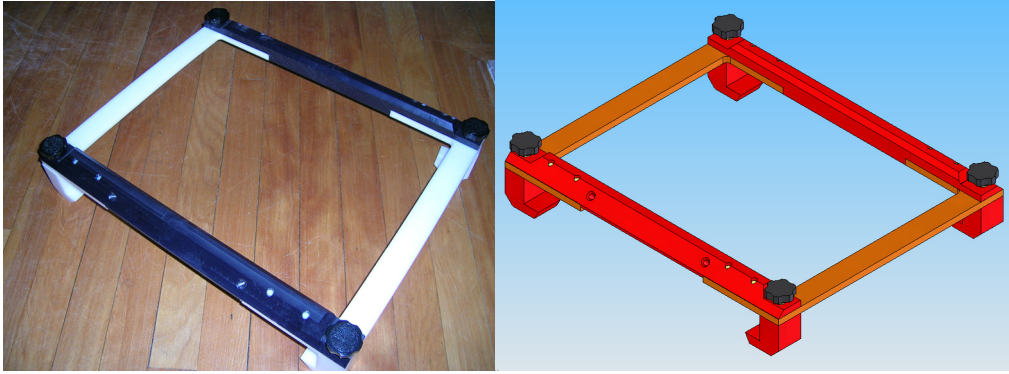

Figure 83: Base Clamp Model.

Coil Holder

The coil holders caused the most difficulty during the entire project from design to machining. While the final redesign seemingly made machining and assembly easier, the result was quite the contrary. Each one of the parts of the locking mechanism was incredibly difficult to fit into place. Once the thumb tabs were attached, it made lining up the pins for the locking mechanism an even more difficult task. In the end, even when everything on the coil holder was assembled, the build quality was lacking as compared to the other subassemblies of this project. The thin plates became incredibly hard to screw down and allow for a smooth rotation about the track on the arms. This design also made assembly and disassembly incredibly difficult. Overall the assembly of the coil holders was below par compared to the rest of the project. In Figure 84 below, the models of the coil holder subassemblies are shown.

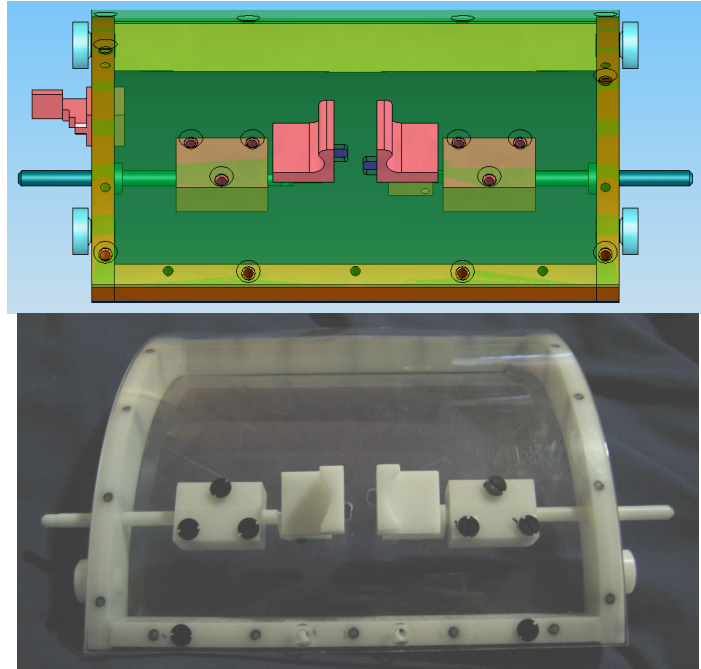

Figure 84: Models of the Coil Holder

The overall fabrication portion of the project ended with some minor errors. The build quality and specific features lived up to our expectations. The materials that we had selected were durable enough for the mechanical operations of the assembly. While there were minor problems that arose during the course of fabricating the project, the end product was something that was mechanically and functionally a success. The resulting project provided the majority of a system that could be combined with custom designed RF coils to image the human knee. With the successful fabrication of the proposed design change on the coil holders we believe that this project could be used in MRI testing.

Conclusions

The project satisfied the theoretical and functional goals originally established. The design process followed a distinct evolution in which innovation met functional requirements and design for manufacturability. The fabrication was completed as specified by the technical drawings. With the aid of computer aided manufacturing software, complex parts were machined through the use of generated machine code. Construction and assembly completed in time to complete testing of the mechanical components. The overall outcome of the project was quite exceptional and met most of the expectations of the team members.

The design overall was a good outline for the task specifications as well as the fabrication portion of the project. The final design was a careful balance of practical design paired with innovation to designs that were currently on the market. During the final design phase, the arms were redesigned so that they could be made using the T-slot cutter. The arms also had tabs added to them in the designs to enable proper fixturing during machining. All of the small pegs and pins were also successfully toleranced in the designs so that they would fit together correctly during assembly. The design was an evolution of functionality and machinability and was completed successfully in a logical progression.

In respect to manufacturing and fabricating the parts of this assembly, the project also lived up to the expectations of the team. All of the smaller parts were machined solely by the project team on manual mills and lathes. For the more complex parts, NC code was created using CAM software. The parts there were fabricated using CNC machine techniques were completed with the best accuracy. There were some special

considerations that had to be taken during CNC machining the Delrin stock but overall these parts were manufactured without flaws. While manual machining was sufficient for a prototype, further versions of this design would greatly benefit from full utilization of CNC machining. While this would increase the overall price of fabrication, the end product would be much more accurate to the design if done by a professional machining company.

The next level of evolution of this project is definitely in the development of the design for the entire mechanical assembly. If the number of parts can be reduced, then the overall assembly time would be reduced. Also if entire subassemblies, such as the base and the table clamp, could be made as single pieces then the overall build quality and sturdiness could increase. Some of the finer details need to be developed further as well. For example the locking pin mechanism needs to be optimized to accommodate the rigid nature of the Delrin and polycarbonate. Many of the smaller features need to be redesigned to ensure that they could be fabricated using appropriate and viable tooling.

The impact and innovation of this project have the potential to outperform other knee MRI coils on the market. The free rotating, multi-angled imaging system, is a feature that could innovate the coil market. With further design evolution and manufacturing being outsourced to a professional source, the project has increased chance of success. We believe that for the scope of the project and the impact that a product such as this would have, that the overall project was a success.

Recommendations

The main recommendation for the evolution of this project is to redesign the coil holders. With the current design, there is too much stress put on the thin plates that line the inner and outer radius of the coil holder. This stress caused for very difficult assembly and modification. Also, since this project is still in the prototype phase, it is important to have easy access to where the RF coils would be stored. For all of these reasons, the project team has suggested the following revision to the coil holders.

To alleviate the problems that occurred with using thin plates, this revision features a solid, two piece construction. The parts would then need to be machined using a CNC mini mill and 2 inch thick Delrin stock. By splitting the coil holders into two separate pieces, the overall construction becomes sturdier and requires less assembly. This change would cost close to \$550 in stock as well as approximately 8 hours of CNC machine time to complete. Because of the drastic improvement of these designs however, it is suggested that they are made in further development in the prototype design. The suggested coil holder halves can be seen in Figure 85.

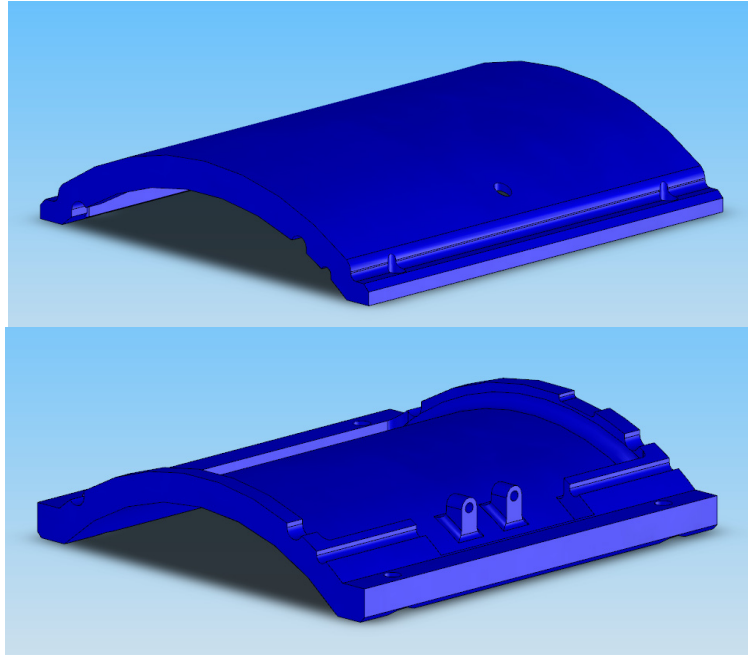

Figure 85: Coil Hole Top and Bottom Parts

When the unit is fully assembled with all the linkages and pins in place it will look like Figure 86. If you notice closely, there are two flanges on either side of the arc. These thin rectangular flanges would not only make it easy to assemble with the tapped thru holes, but would also facilitate the machining of the parts by allowing the parts to be fixtured to the CNC Mini-Mill's vice.

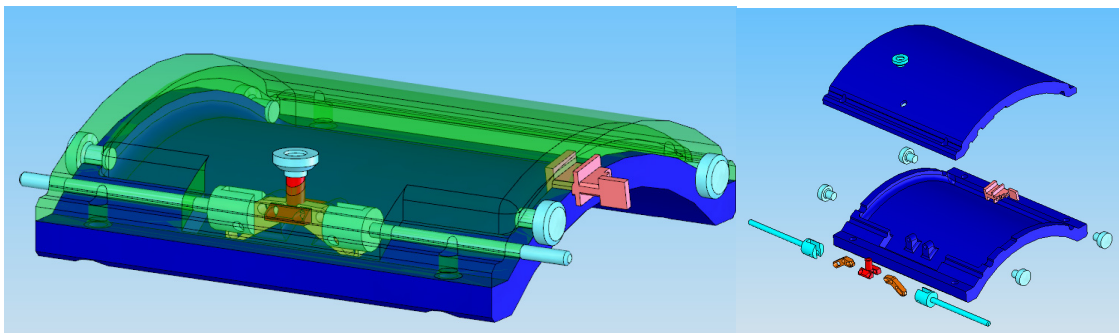

Figure 86: Completed Coil Enclosure with Exploded View.

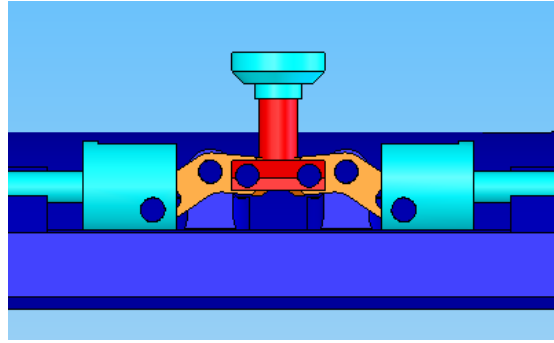

Figure 87: Revised Locking Mechanism.

Overall it is suggested that the coil holder revision be made along with some slight changes to the entire prototype. Further revisions of this project should incorporate better design for manufacturability as well as fewer parts for easier assembly. The build quality and tolerancing would also improve if the project was outsourced to a professional machine shop. Further testing also needs to be done to ensure the image quality of the coils within the coil holder. While there are few changes that are suggested, these changes could drastically improve the quality of further development of this project.

Bibliography

"A Patient's Guide to Osteoarthritis of the Knee." Knee Osteoarthritis. 15 Mar 2005.

OrthoPod. 19 Feb. 2006

<<http://www.eorthopod.com/eorthopodV2/index.php/fuseaction/topics.detail/ID/8ecc09b02bc8eb9010a76c099e052232/TopicID/dd675b971fc6f99dead0f6c8fb45e8c6/area/17>>.

Brown, Mark A., and Richard C. Semelka. MRI Basic Principles and Applications. 2nd ed. New York: Wiley-Liss, 1999.

Case, Julia . "American Men and Women for Human Engineering." The source is MIL-STD-1472D. Gender Web. 12 Oct. 2005

<http://www.genderweb.org/general/ave_bo.phtml>.

Devitt, Terry. "Nobel Prize Fight." Why Files. 1 Jan 2003. University of Wisconsin. 19 Feb. 2006 <http://whyfiles.org/188nobel_mri/>.

Head, Kay. "Design of RF Pulses and Magnetic Field Gradients." Magnetic Resonance Group. 21 April 2005. University of Nottingham. 14 Sep. 2005

<http://www.magres.nottingham.ac.uk/projects/pulses_gradients/>.

Hornak, Ph.D, Joseph P. The Basics of MRI. 24 2006. Center for Imaging Science. 28 Mar. 2006 <<http://www.cis.rit.edu/htbooks/mri/inside.htm>>.

Lauterbur, Paul., and Liang, Zhi-Pei. Principles of Magnetic Resonance Imaging. 1st ed. New York: IEEE Press Marketing, 2000.

"Material Property Data." Materials Information. 1 Jan 2005. MatWeb. 12 Oct. 2005

<<http://www.matweb.com/index.asp?ckck=1>>.

"Resources for MRI Students." Vision. 20 June 2003. Greg Brown Royal Adelaide
Hospital MRI Unit. 14 Sep. 2005

<<http://www.users.on.net/~vision/misc/usa.htm>>.

Weisskoff, Ph.D., Robert M. "Physical Foundations of MR Imaging." NMR Physics
Research and the Hyperscan Imaging Laboratory. 1 Jan. 1991. Massachusetts
General Hospital Department of Radiology. 14 Sep. 2005

<<http://airto.bmap.ucla.edu/BMCweb/CourseWork/M285/MRI/RMWFundamentals.html>>.

Young, Iran R. Methods in Biomedical Magnetic Resonance Imaging and Spectroscopy.
1st Vol. New York: John Wiley & Sons, LTD, 2000.

Young, Iran R. Methods in Biomedical Magnetic Resonance Imaging and Spectroscopy.
2nd Vol. New York: John Wiley & Sons, LTD, 2000.

Appendices

Technical Drawings

Base Clamp Components

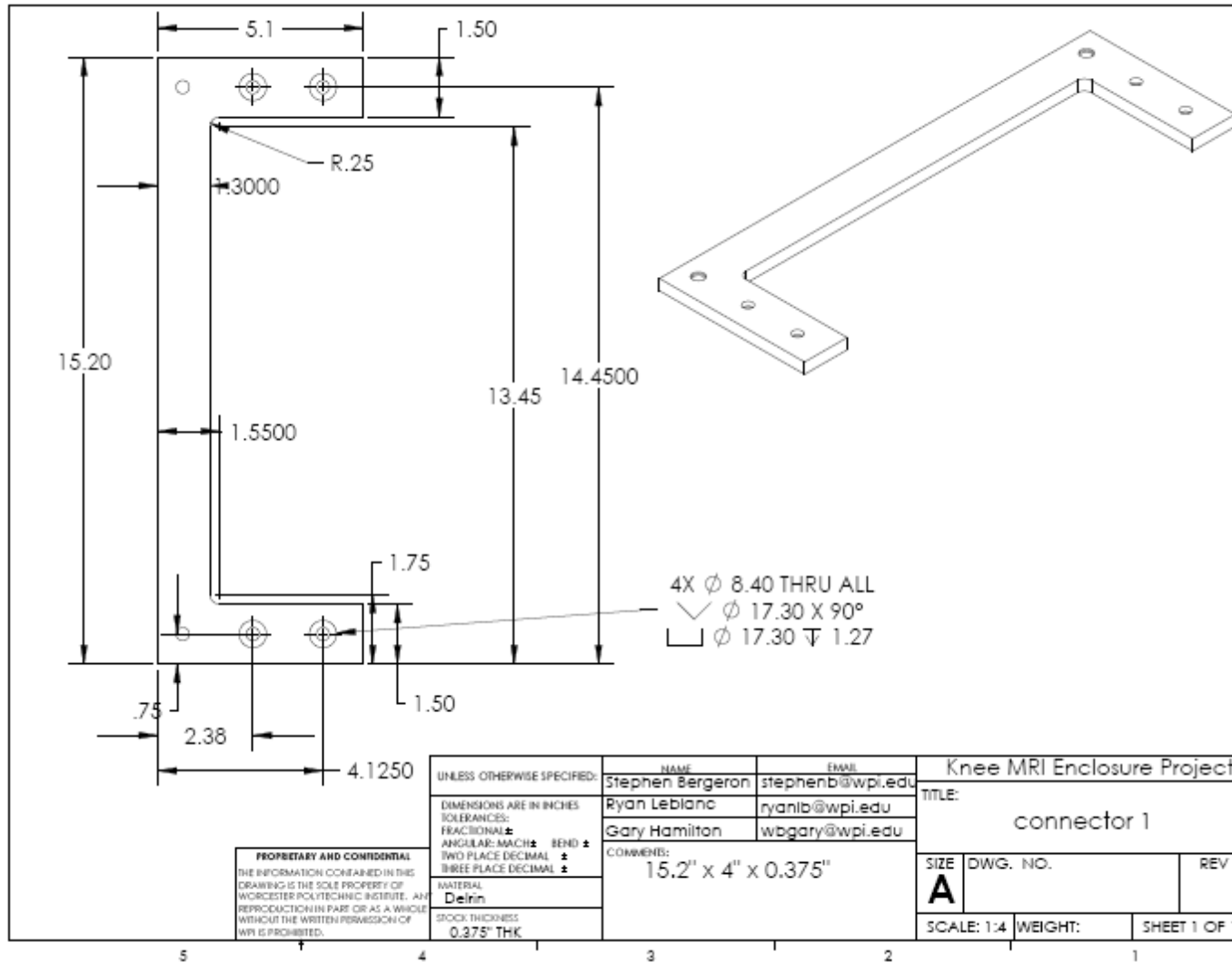

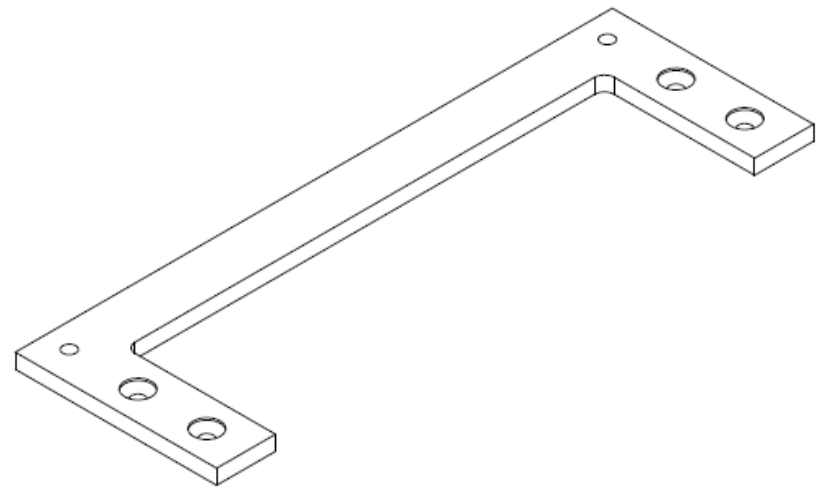
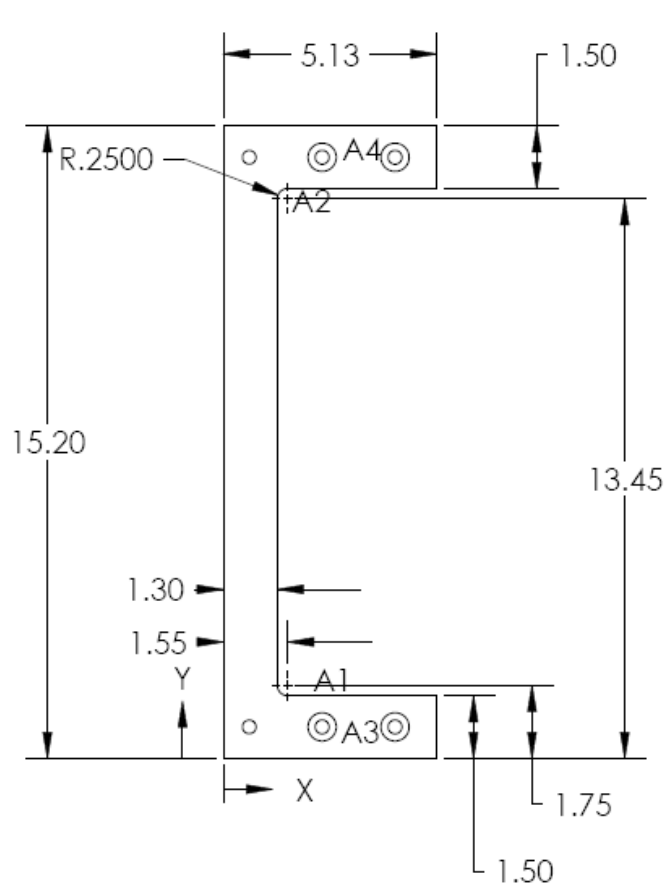

TAG	X LOC	Y LOC	SIZE
A1	2.38	.75	$\phi .3307$ THRU ALL $\checkmark \phi .6811 \times 90^\circ$ $\square \phi .6811 \nabla .0500$
A2	2.38	14.45	
A3	4.13	.75	
A4	4.13	14.45	

UNLESS OTHERWISE SPECIFIED: DIMENSIONS ARE IN INCHES TOLERANCES: FRACTIONAL: \pm ANGULAR: MACH \pm BEND \pm TWO PLACE DECIMAL \pm THREE PLACE DECIMAL \pm	NAME	EMAIL	Knee MRI Enclosure Project		
	Stephen Bergeron	stephenb@wpi.edu	TITLE: Connector 2		
	Ryan Leblanc	ryanlb@wpi.edu			
	Gary Hamilton	wbgary@wpi.edu			
	COMMENTS:	15.2" x 4" x 0.375"			
MATERIAL Delrin			SIZE A	DWG. NO.	REV
STOCK THICKNESS 0.375" THK			SCALE: 1:1	WEIGHT:	SHEET 1 OF 1

PROPRIETARY AND CONFIDENTIAL
 THE INFORMATION CONTAINED IN THIS
 DRAWING IS THE SOLE PROPERTY OF
 WORCESTER POLYTECHNIC INSTITUTE. ANY
 REPRODUCTION IN PART OR AS A WHOLE
 WITHOUT THE WRITTEN PERMISSION OF
 WPI IS PROHIBITED.

5

4

3

2

1

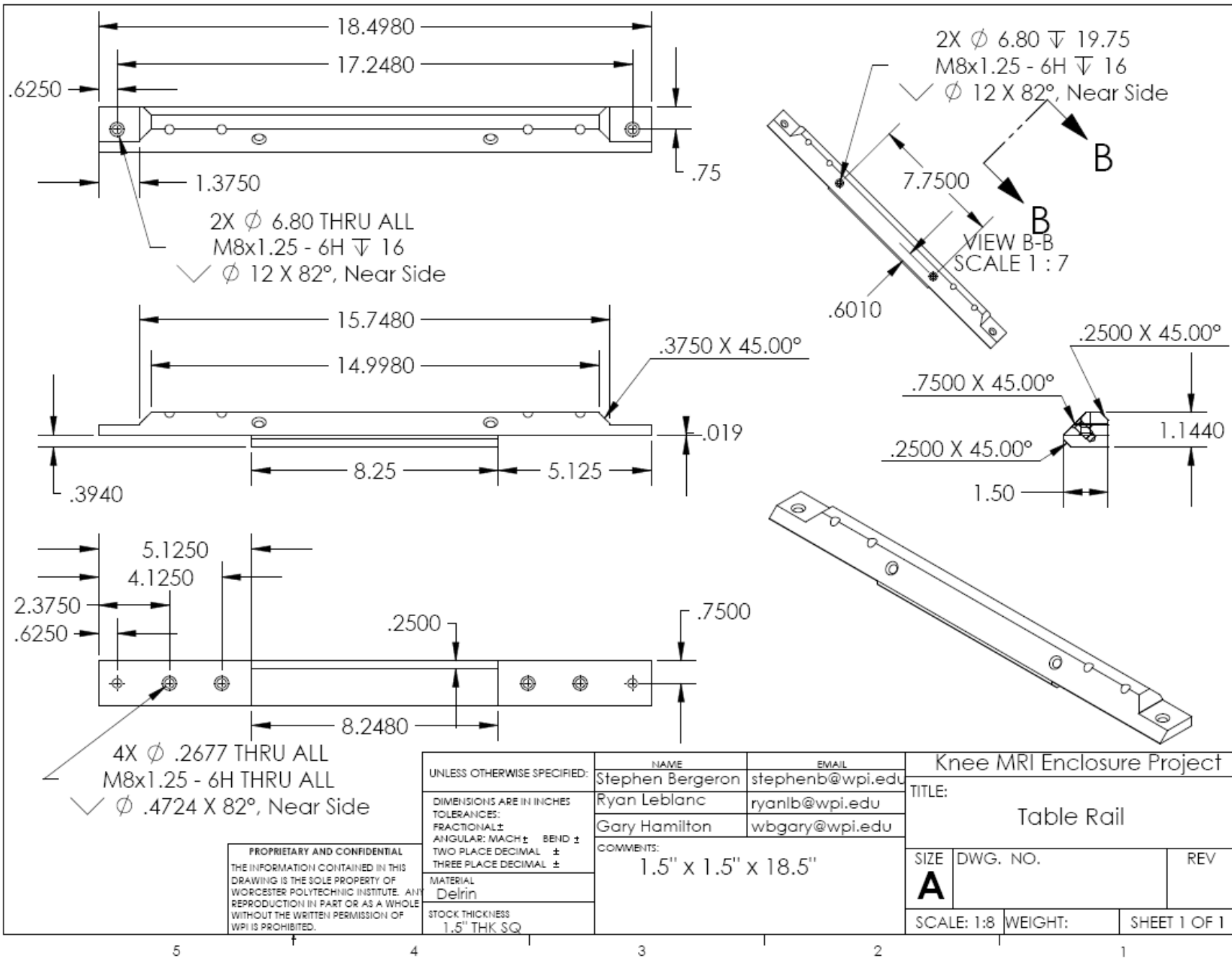

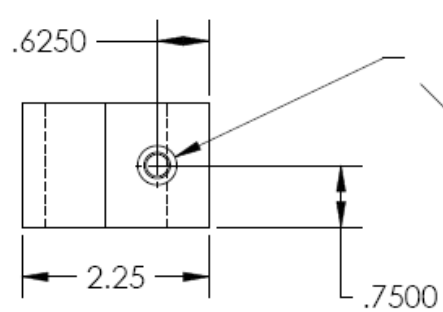

ϕ 6.80 \mp 19.75
 M8x1.25 - 6H \mp 16
 \surd ϕ 12 X 82°, Near Side

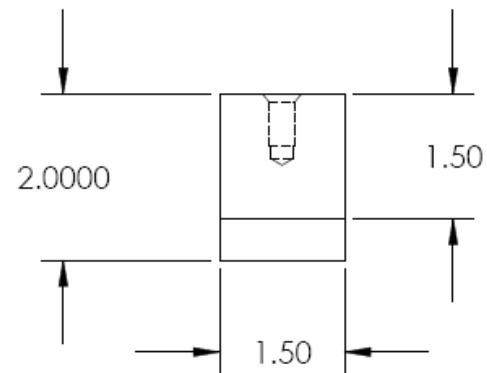
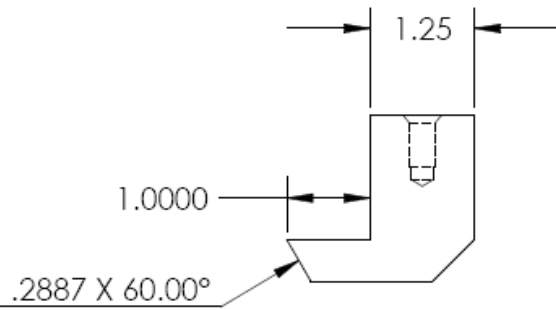
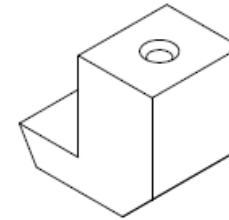

PROPRIETARY AND CONFIDENTIAL
 THE INFORMATION CONTAINED IN THIS
 DRAWING IS THE SOLE PROPERTY OF
 WORCESTER POLYTECHNIC INSTITUTE. ANY
 REPRODUCTION IN PART OR AS A WHOLE
 WITHOUT THE WRITTEN PERMISSION OF
 WPI IS PROHIBITED.

UNLESS OTHERWISE SPECIFIED:
 DIMENSIONS ARE IN INCHES
 TOLERANCES:
 FRACTIONAL \pm
 ANGULAR: MACH \pm BEND \pm
 TWO PLACE DECIMAL \pm
 THREE PLACE DECIMAL \pm
 MATERIAL
 Delrin
 STOCK THICKNESS
 1.5" THK

NAME	EMAIL
Stephen Bergeron	stephenb@wpi.edu
Ryan Leblanc	ryanib@wpi.edu
Gary Hamilton	wbgary@wpi.edu

COMMENTS:
 3.25" x 3" x 1.5"

Knee MRI Enclosure Project		
TITLE: Under Hook		
SIZE A	DWG. NO.	REV
SCALE: 1:2	WEIGHT:	SHEET 1 OF 1

Base Components

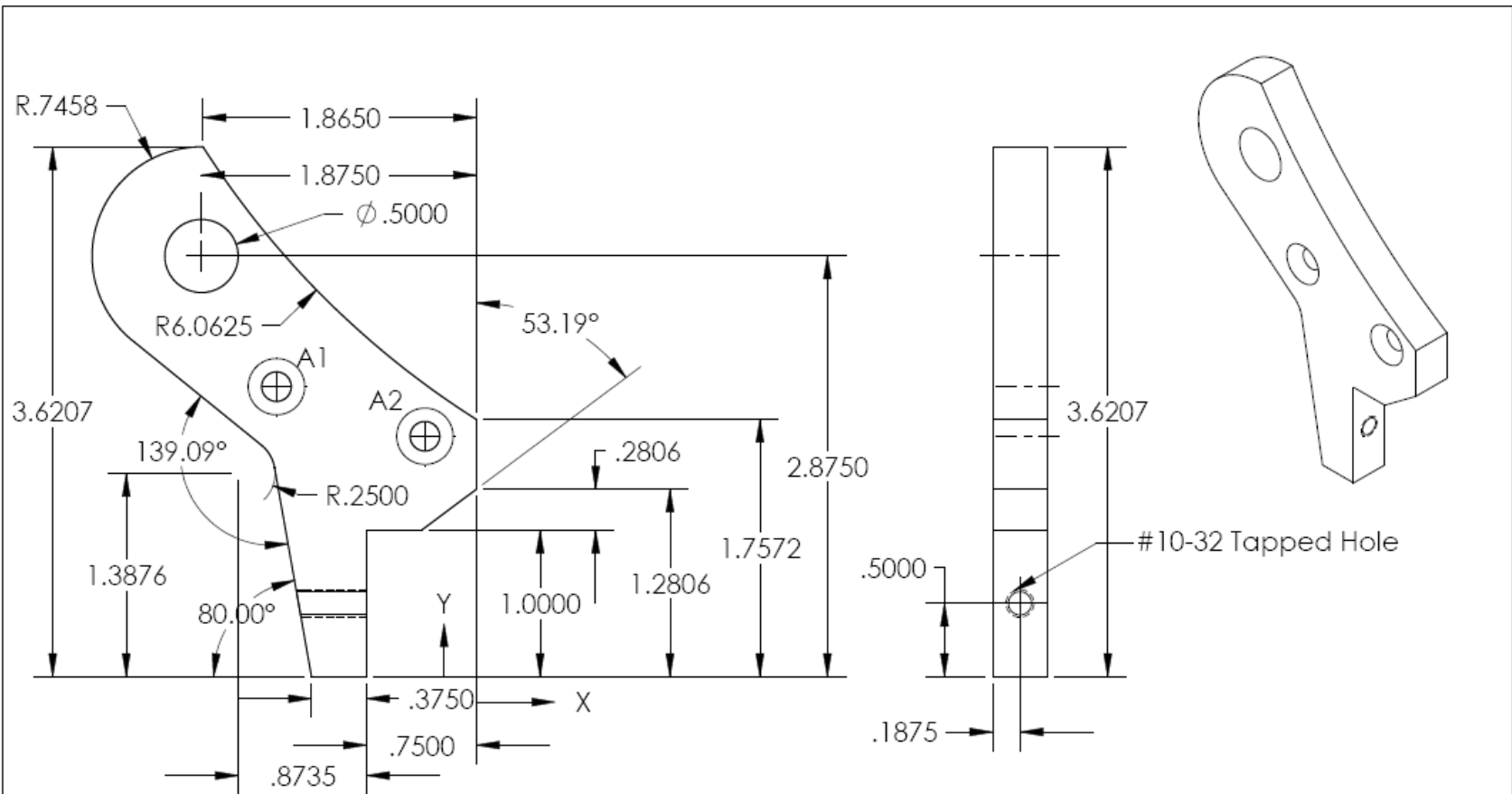

TAG	X LOC	Y LOC	SIZE
A1	-1.3633	1.9815	$\phi .2010$ THRU ALL $\phi .3850 \times 82^\circ$
A2	-.3507	1.6419	

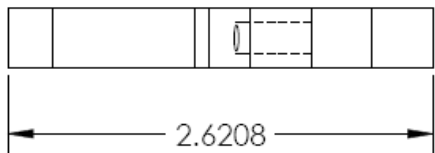

PROPRIETARY AND CONFIDENTIAL
 THE INFORMATION CONTAINED IN THIS DRAWING IS THE SOLE PROPERTY OF WORCESTER POLYTECHNIC INSTITUTE. ANY REPRODUCTION IN PART OR AS A WHOLE WITHOUT THE WRITTEN PERMISSION OF WPI IS PROHIBITED.

UNLESS OTHERWISE SPECIFIED:
 DIMENSIONS ARE IN INCHES
 TOLERANCES:
 FRACTIONAL: \pm
 ANGULAR: MACH \pm BEND \pm
 TWO PLACE DECIMAL \pm
 THREE PLACE DECIMAL \pm
 MATERIAL
 Delrin
 STOCK THICKNESS
 0.375" THK

NAME	EMAIL
Stephen Bergeron	stephenb@wpi.edu
Ryan Leblanc	ryanlb@wpi.edu
Gary Hamilton	wbgary@wpi.edu

COMMENTS:
 0.375" x 2.6" x 3.63"

Knee MRI Enclosure Project		
TITLE: Arm Support 1		
SIZE A	DWG. NO.	REV
SCALE: 1:1	WEIGHT:	SHEET 1 OF 1

5 4 3 2 1

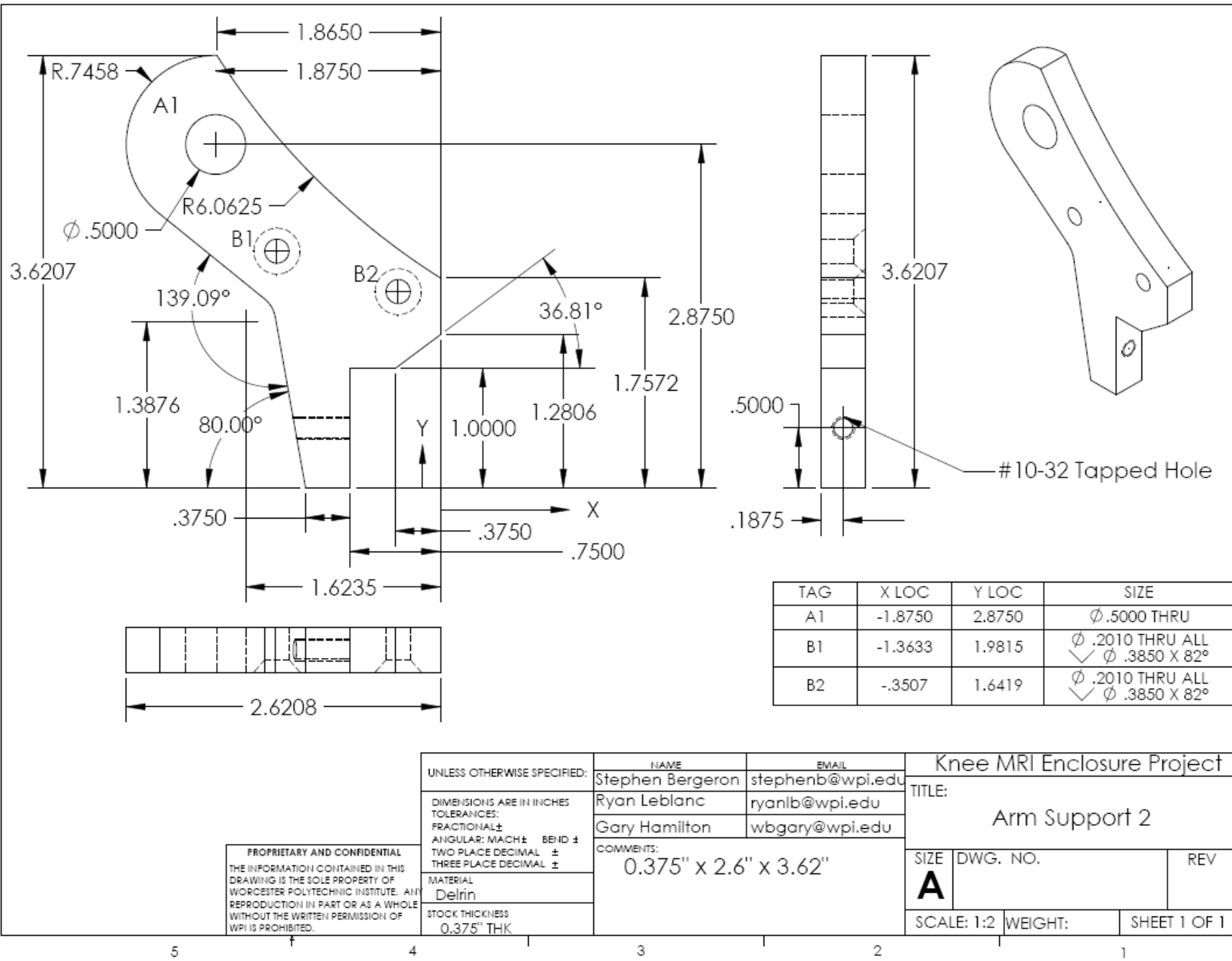

TAG	X LOC	Y LOC	SIZE
A1	.2141	.3750	ϕ .1590 THRU ALL 10-32 UNF - 2B THRU ALL
A2	.6641	.7001	
A3	1.0892	.2499	
A4	1.2141	.7500	

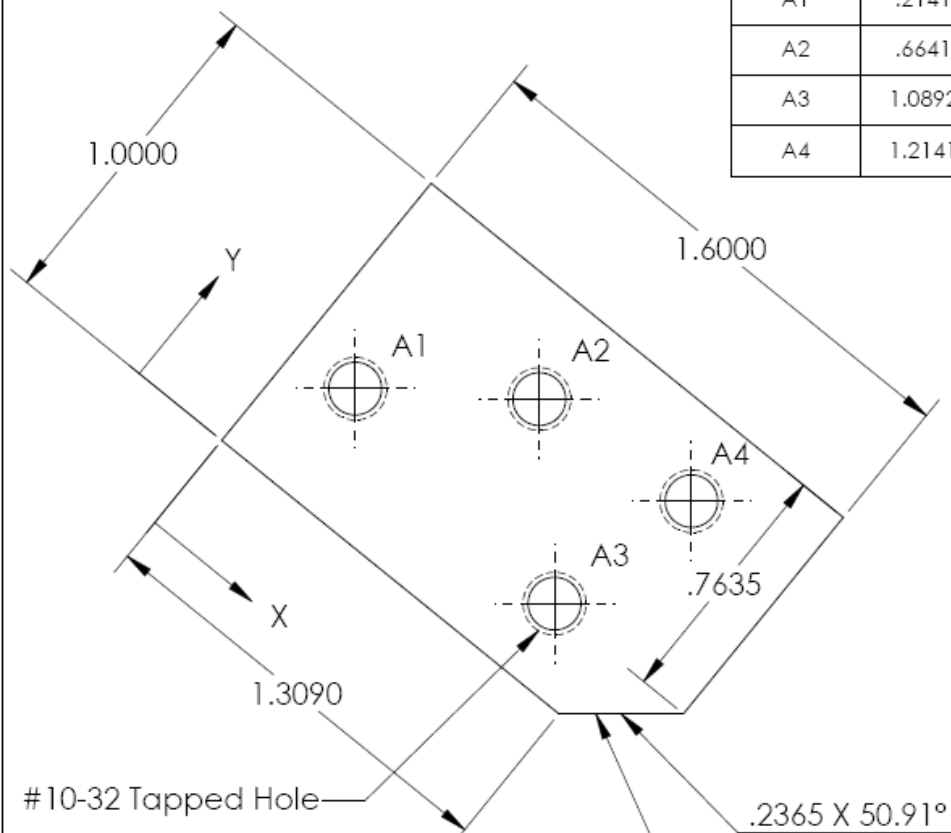

Holes A2 & A3 are tapped in the same direction. Holes A1 & A4 are tapped in the same direction, but from the reverse direction of A2 & A3.

This component is to be created 4 times total. Two instances of the part are to have A2 & A3 tapped from one direction, and the other two instances are to be tapped from the other side. Alternate Tap direction for each set of tapped holes.

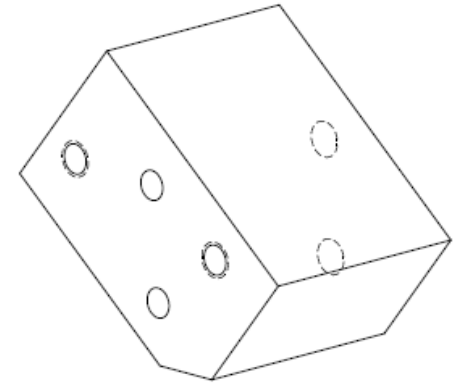

PROPRIETARY AND CONFIDENTIAL
 THE INFORMATION CONTAINED IN THIS DRAWING IS THE SOLE PROPERTY OF WORCESTER POLYTECHNIC INSTITUTE. ANY REPRODUCTION IN PART OR AS A WHOLE WITHOUT THE WRITTEN PERMISSION OF WPI IS PROHIBITED.

UNLESS OTHERWISE SPECIFIED:
 DIMENSIONS ARE IN INCHES
 TOLERANCES:
 FRACTIONAL: ±
 ANGULAR: MACH ± BEND ±
 TWO PLACE DECIMAL ±
 THREE PLACE DECIMAL ±
 MATERIAL
 Delrin
 STOCK THICKNESS
 1.50" THK

NAME	EMAIL
Stephen Bergeron	stephenb@wpi.edu
Ryan Leblanc	ryanlb@wpi.edu
Gary Hamilton	wbgary@wpi.edu

COMMENTS:
 1.08" x 1.25" x 1.75"

Knee MRI Enclosure Project		
TITLE: Arm Support Standoff		
SIZE A	DWG. NO.	REV
SCALE: 1:1	WEIGHT:	SHEET 1 OF 1

5 4 3 2 1

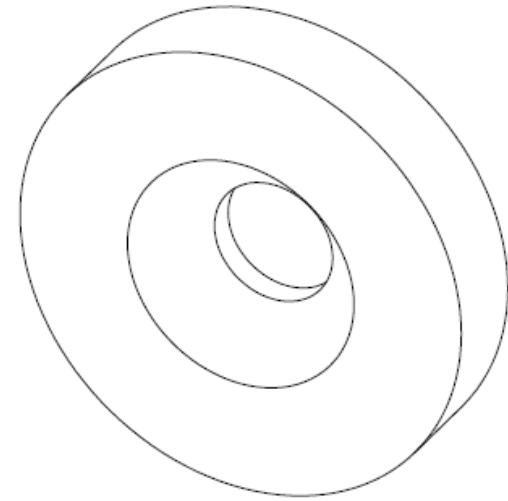
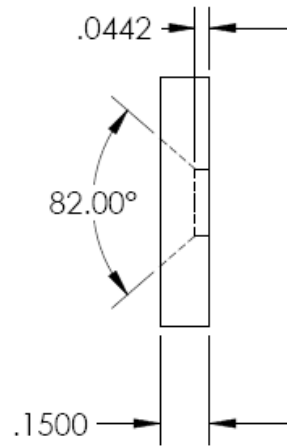
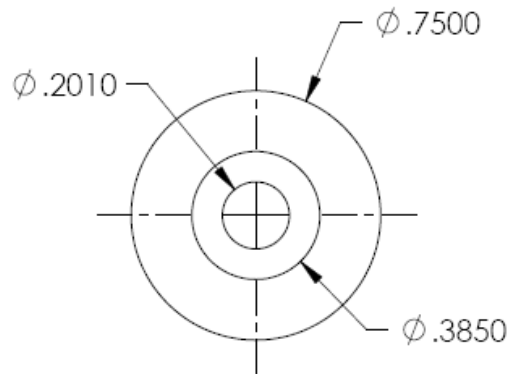

PROPRIETARY AND CONFIDENTIAL
 THE INFORMATION CONTAINED IN THIS
 DRAWING IS THE SOLE PROPERTY OF
 WORCESTER POLYTECHNIC INSTITUTE. ANY
 REPRODUCTION IN PART OR AS A WHOLE
 WITHOUT THE WRITTEN PERMISSION OF
 WPI IS PROHIBITED.

UNLESS OTHERWISE SPECIFIED: DIMENSIONS ARE IN INCHES TOLERANCES: FRACTIONAL ± ANGULAR: MACH ± BEND ± TWO PLACE DECIMAL ± THREE PLACE DECIMAL ± MATERIAL Delrin STOCK THICKNESS 0.75" Diameter	NAME	EMAIL	Knee MRI Enclosure Project	
	Stephen Bergeron	stephenb@wpi.edu	TITLE:	
	Ryan Leblanc	ryanlb@wpi.edu	Base Arm Cover	
	Gary Hamilton	wbgary@wpi.edu	SIZE	DWG. NO.
COMMENTS: 0.75" Diameter x 0.15"		REV		
		SCALE: 2:1	WEIGHT:	SHEET 1 OF 1

5

4

3

2

1

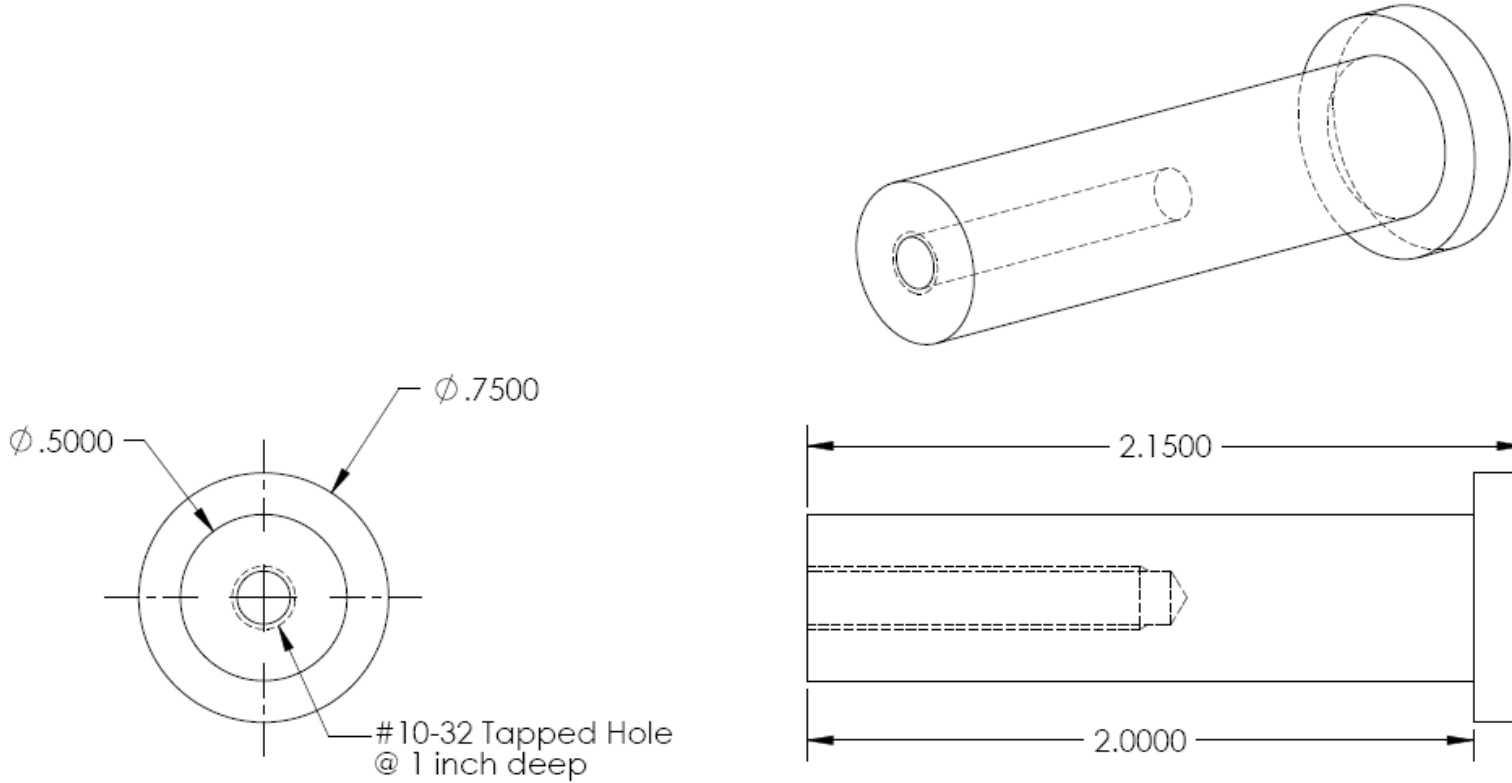

PROPRIETARY AND CONFIDENTIAL
 THE INFORMATION CONTAINED IN THIS
 DRAWING IS THE SOLE PROPERTY OF
 WORCESTER POLYTECHNIC INSTITUTE. ANY
 REPRODUCTION IN PART OR AS A WHOLE
 WITHOUT THE WRITTEN PERMISSION OF
 WPI IS PROHIBITED.

UNLESS OTHERWISE SPECIFIED:	NAME	EMAIL	Knee MRI Enclosure Project		
	Stephen Bergeron	stephenb@wpi.edu	TITLE: Base Arm Pin		
	Ryan Leblanc	ryanib@wpi.edu			
DIMENSIONS ARE IN INCHES TOLERANCES: FRACTIONAL: ± ANGULAR: MACH ± BEND ± TWO PLACE DECIMAL ± THREE PLACE DECIMAL ±	Gary Hamilton	wbgary@wpi.edu	SIZE	DWG. NO.	REV
MATERIAL Delrin	COMMENTS: 0.75" Diameter x 2.15"		A		
STOCK THICKNESS 0.75" Diameter				SCALE: 1:1	WEIGHT:

5 4 3 2 1

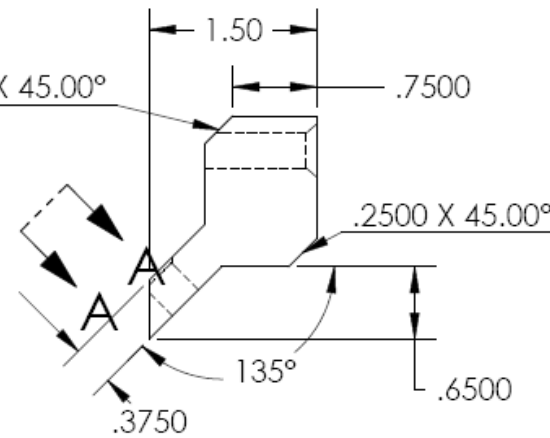
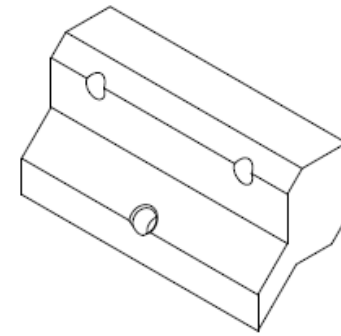
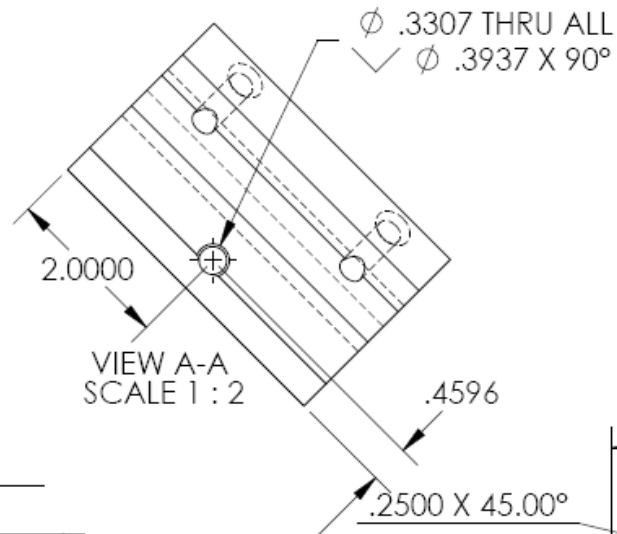
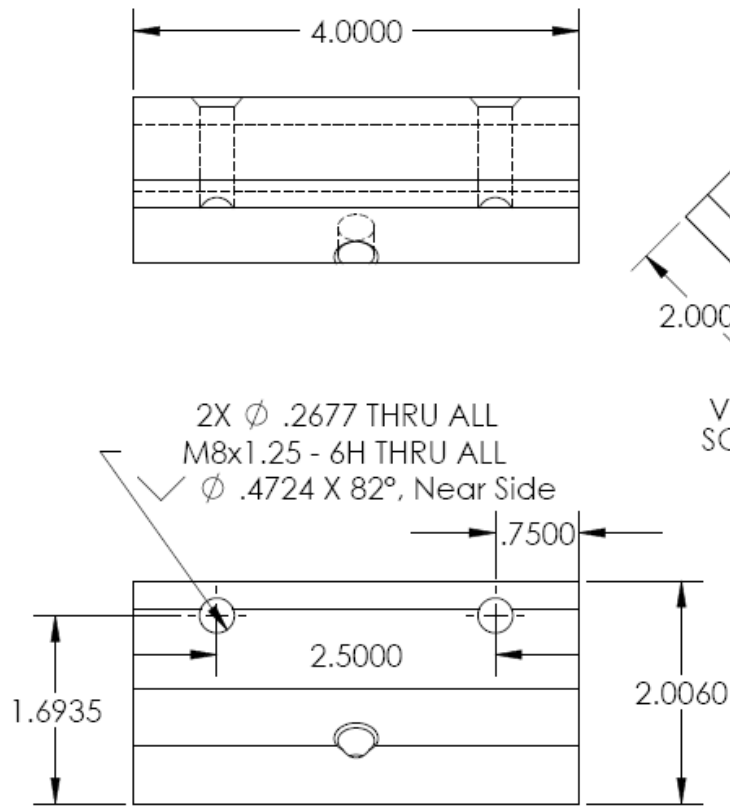

PROPRIETARY AND CONFIDENTIAL
 THE INFORMATION CONTAINED IN THIS
 DRAWING IS THE SOLE PROPERTY OF
 WORCESTER POLYTECHNIC INSTITUTE. ANY
 REPRODUCTION IN PART OR AS A WHOLE
 WITHOUT THE WRITTEN PERMISSION OF
 WPI IS PROHIBITED.

UNLESS OTHERWISE SPECIFIED: DIMENSIONS ARE IN INCHES TOLERANCES: FRACTIONAL: ± ANGULAR: MACH ± BEND ± TWO PLACE DECIMAL ± THREE PLACE DECIMAL ± MATERIAL Delrin STOCK THICKNESS	NAME	EMAIL	Knee MRI Enclosure Project	
	Stephen Bergeron	stephenb@wpi.edu	TITLE:	
	Ryan Leblanc	ryanlb@wpi.edu	Base Bracket	
	Gary Hamilton	wbgary@wpi.edu	REV	
	COMMENTS:	4.0" x 1.65" x Delrin 1.5"		SIZE
				A
		SCALE: 1:1	WEIGHT:	SHEET 1 OF 1

5

4

3

2

1

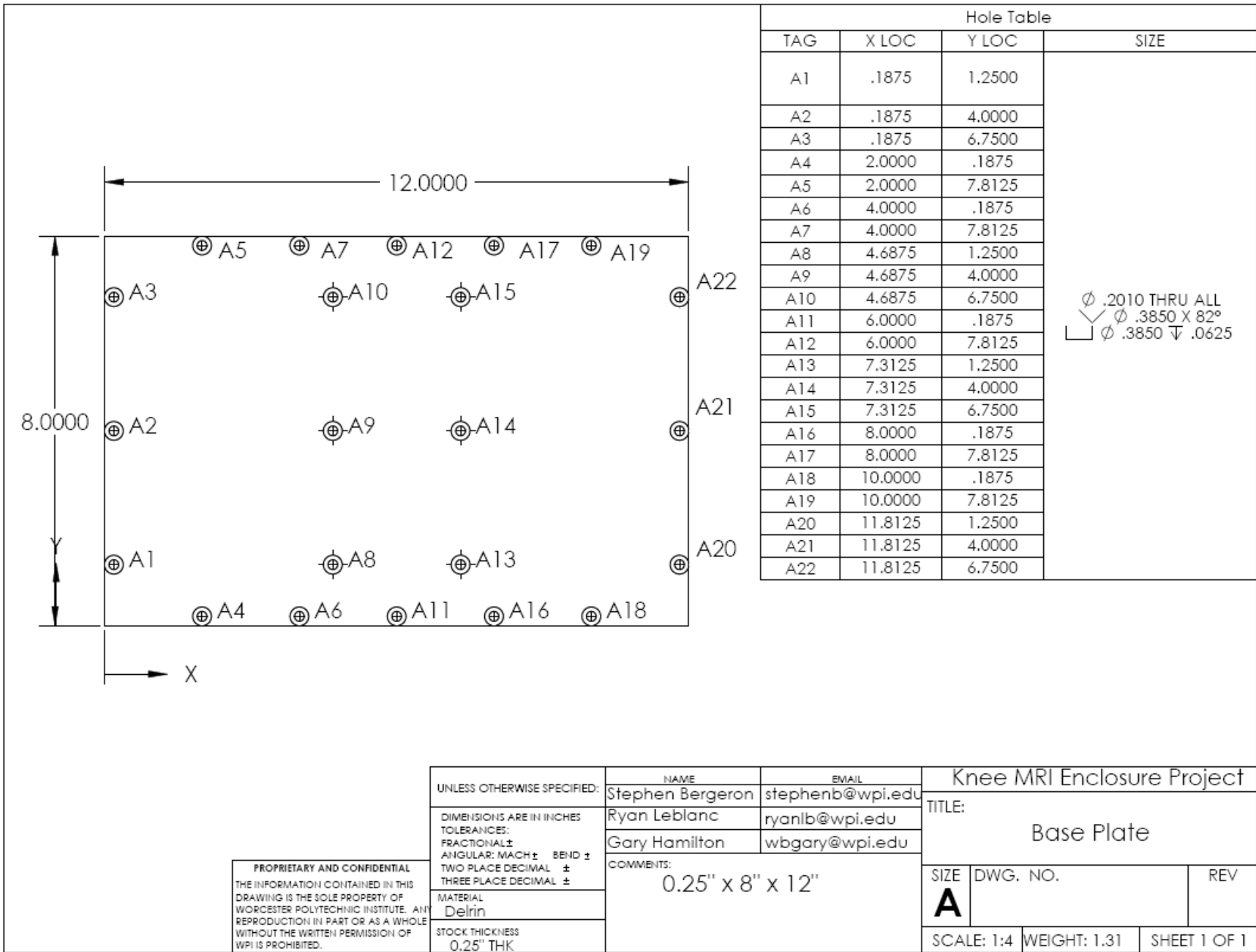

PROPRIETARY AND CONFIDENTIAL
 THE INFORMATION CONTAINED IN THIS
 DRAWING IS THE SOLE PROPERTY OF
 WORCESTER POLYTECHNIC INSTITUTE. ANY
 REPRODUCTION IN PART OR AS A WHOLE
 WITHOUT THE WRITTEN PERMISSION OF
 WPI IS PROHIBITED.

UNLESS OTHERWISE SPECIFIED:
 DIMENSIONS ARE IN INCHES
 TOLERANCES:
 FRACTIONAL ±
 ANGULAR: MACH ± BEND ±
 TWO PLACE DECIMAL ±
 THREE PLACE DECIMAL ±
 MATERIAL
 Delrin
 STOCK THICKNESS
 0.25" THK

NAME	EMAIL
Stephen Bergeron	stephenb@wpi.edu
Ryan Leblanc	ryanlb@wpi.edu
Gary Hamilton	wbgary@wpi.edu

COMMENTS:
 0.25" x 8" x 12"

Knee MRI Enclosure Project

TITLE:
 Base Plate

SIZE	DWG. NO.	REV
A		
SCALE: 1:4	WEIGHT: 1.31	SHEET 1 OF 1

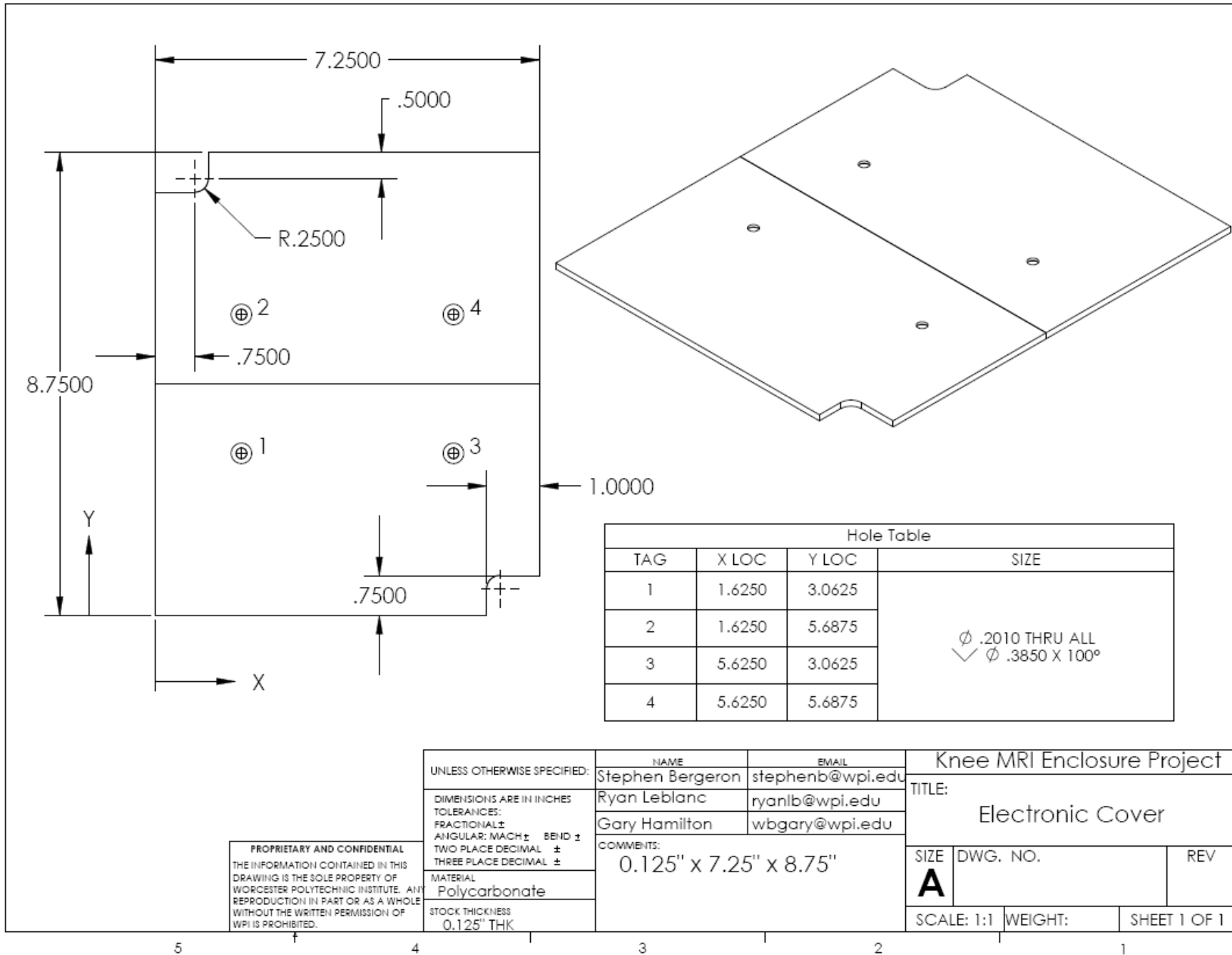

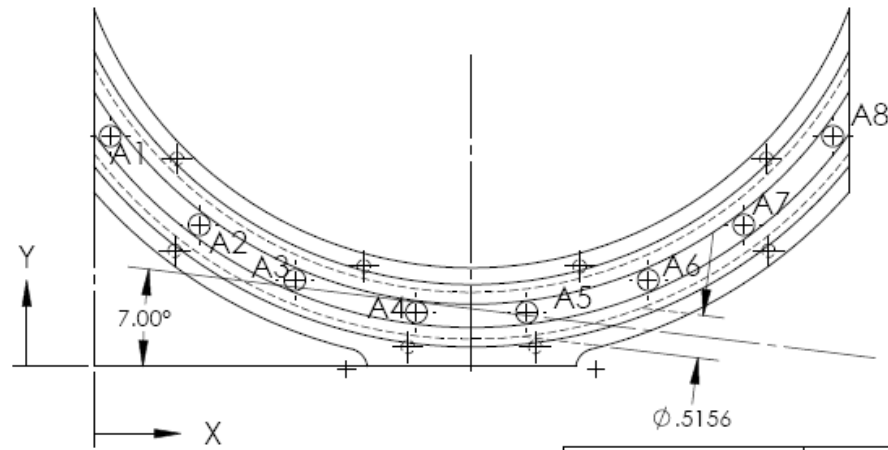
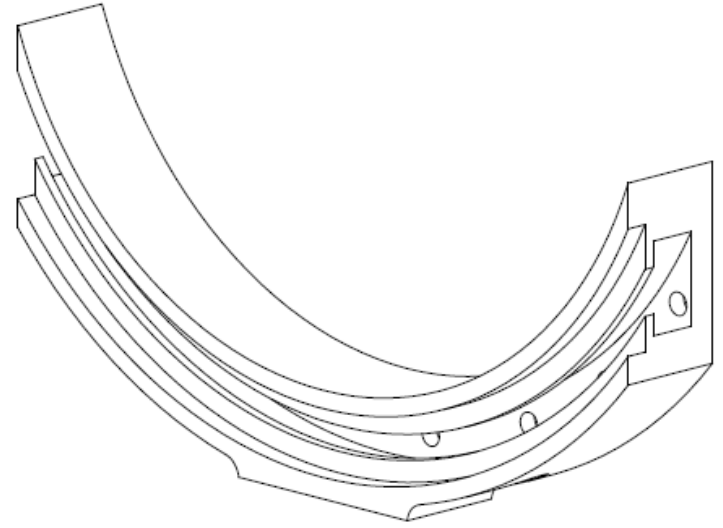
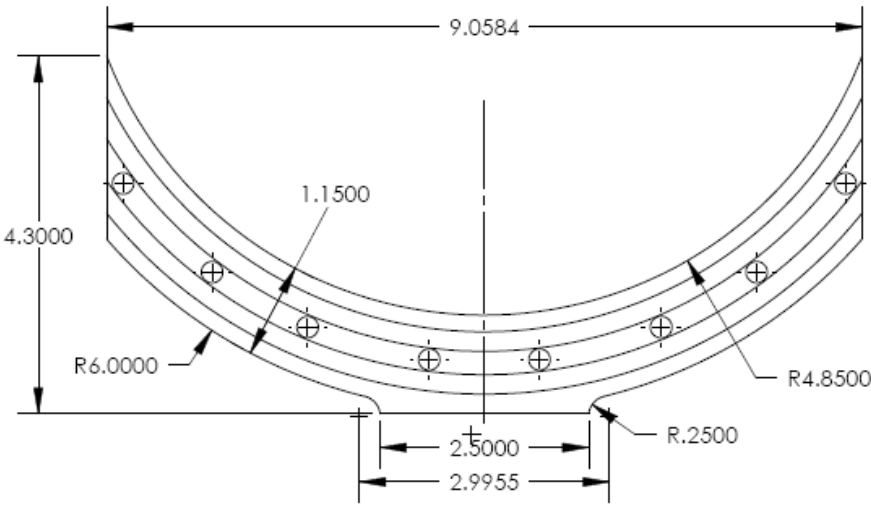

Hole Table			
TAG	X LOC	Y LOC	SIZE
A1	.1968	2.7695	Ø.2570 ∓ .0125
A2	1.2641	1.7022	
A3	2.4098	1.0407	
A4	3.8677	.6501	
A5	5.1907	.6501	
A6	6.6486	1.0407	
A7	7.7943	1.7022	
A8	8.8616	2.7695	

PROPRIETARY AND CONFIDENTIAL
 THE INFORMATION CONTAINED IN THIS
 DRAWING IS THE SOLE PROPERTY OF
 WORCESTER POLYTECHNIC INSTITUTE. AN
 REPRODUCTION IN PART OR AS A WHOLE
 WITHOUT THE WRITTEN PERMISSION OF
 WPI IS PROHIBITED.

UNLESS OTHERWISE SPECIFIED:
 DIMENSIONS ARE IN INCHES
 TOLERANCES:
 FRACTIONAL: ±
 ANGULAR: MACH ± BEND ±
 TWO PLACE DECIMAL ±
 THREE PLACE DECIMAL ±
 MATERIAL
 Delrin
 STOCK THICKNESS
 1.50" THK

NAME	EMAIL
Stephen Bergeron	stephenb@wpi.edu
Ryan Leblanc	ryanlb@wpi.edu
Gary Hamilton	wbgary@wpi.edu
COMMENTS: 1.25" x 4.3" x 9.1"	

Knee MRI Enclosure Project		
TITLE: Guide Rail		
SIZE A	DWG. NO.	REV
SCALE: 1:1	WEIGHT: 0.3544	SHEET 1 OF 2

5 4 3 2 1

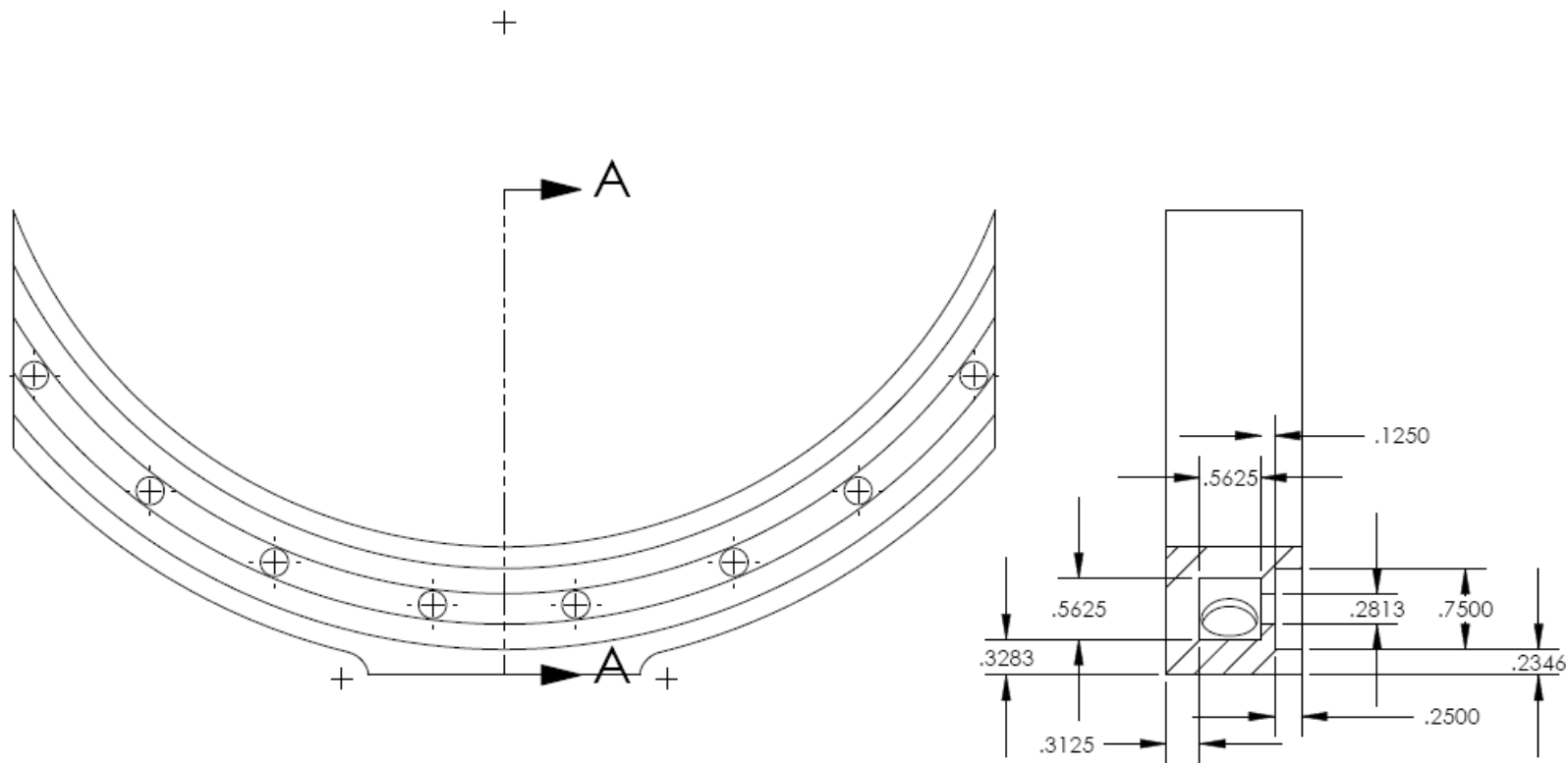

SECTION A-A
SCALE 1 : 1.5

PROPRIETARY AND CONFIDENTIAL
THE INFORMATION CONTAINED IN THIS DRAWING IS THE SOLE PROPERTY OF WORCESTER POLYTECHNIC INSTITUTE. ANY REPRODUCTION IN PART OR AS A WHOLE WITHOUT THE WRITTEN PERMISSION OF WPI IS PROHIBITED.

UNLESS OTHERWISE SPECIFIED:
DIMENSIONS ARE IN INCHES
TOLERANCES:
FRACTIONAL ±
ANGULAR: MACH ± BEND ±
TWO PLACE DECIMAL ±
THREE PLACE DECIMAL ±
MATERIAL
Delrin
STOCK THICKNESS
1.50" THK

NAME	EMAIL
Stephen Bergeron	stephenb@wpi.edu
Ryan Leblanc	ryanlb@wpi.edu
Gary Hamilton	wbgary@wpi.edu
COMMENTS:	
1.25" x 4.3" x 9.1"	

Knee MRI Enclosure Project		
TITLE:		
Guide Rail		
SIZE	DWG. NO.	REV
A		
SCALE: 1:4	WEIGHT: 0.3544	SHEET 2 OF 2

5 4 3 2 1

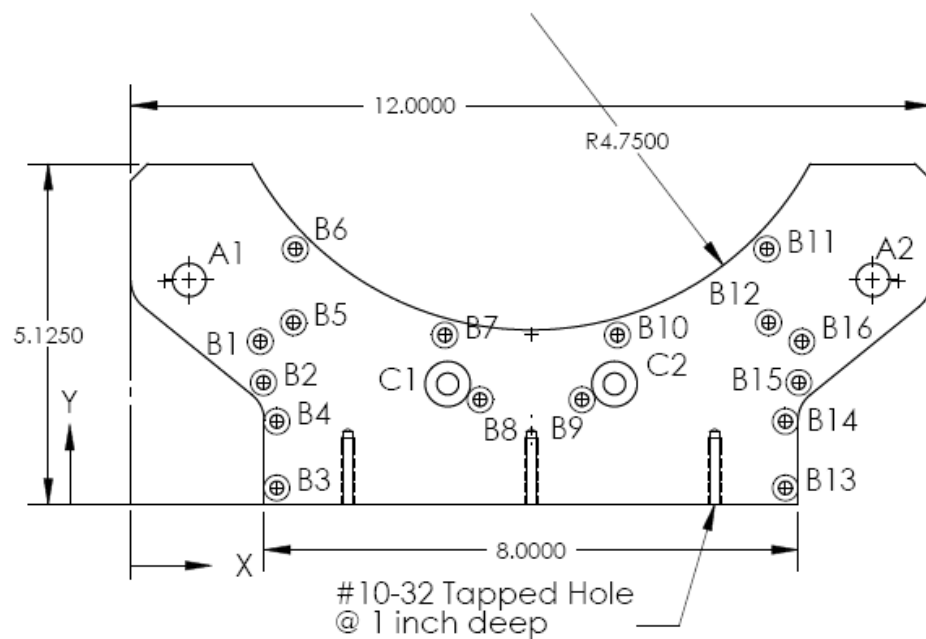

TAG	X LOC	Y LOC	SIZE
A1	.8750	3.3750	Ø .5000 THRU ALL
A2	11.1250	3.3750	
B1	1.9410	2.4500	Ø .2010 THRU ALL √ Ø .3850 X 82°
B2	1.9870	1.8325	
B3	2.1875	.2500	
B4	2.1875	1.2500	
B5	2.4385	2.7340	
B6	2.4645	3.8395	
B7	4.7060	2.5455	
B8	5.2365	1.5750	
B9	6.7635	1.5750	
B10	7.2940	2.5455	
B11	9.5355	3.8395	
B12	9.5615	2.7340	
B13	9.8125	.2500	
B14	9.8125	1.2500	
B15	10.0130	1.8325	
B16	10.0590	2.4500	
C1	4.7500	1.8125	Ø .3307 THRU ALL √ Ø .6811 X 90° □ Ø .6811 ∇ .0500
C2	7.2500	1.8125	

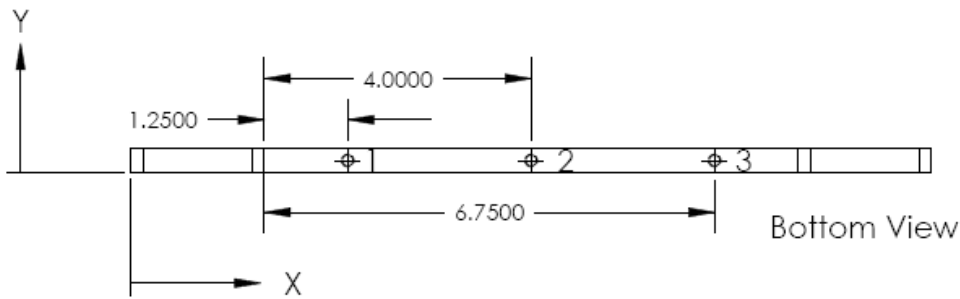

TAG	X LOC	Y LOC	SIZE
1	3.2500	.1875	Ø .1590 ∇ 1.0936 10-32 UNF - 2B ∇ 1.0000
2	6.0000	.1875	
3	8.7500	.1875	

PROPRIETARY AND CONFIDENTIAL
 THE INFORMATION CONTAINED IN THIS
 DRAWING IS THE SOLE PROPERTY OF
 WORCESTER POLYTECHNIC INSTITUTE. ANY
 REPRODUCTION IN PART OR AS A WHOLE
 WITHOUT THE WRITTEN PERMISSION OF
 WPI IS PROHIBITED.

UNLESS OTHERWISE SPECIFIED:
 DIMENSIONS ARE IN INCHES
 TOLERANCES:
 FRACTIONAL ±
 ANGULAR: MACH ± BEND ±
 TWO PLACE DECIMAL ±
 THREE PLACE DECIMAL ±
 MATERIAL
 Delrin
 STOCK THICKNESS
 0.375" THK

NAME	EMAIL
Stephen Bergeron	stephenb@wpi.edu
Ryan Leblanc	ryanlb@wpi.edu
Gary Hamilton	wbgary@wpi.edu

COMMENTS:
 0.375" x 5.13" x 12"

Knee MRI Enclosure Project

TITLE:
 Side Coil Guides

SIZE A	DWG. NO.	REV 2
SCALE: 1:1	WEIGHT:	SHEET 1 OF 2

5 4 3 2 1

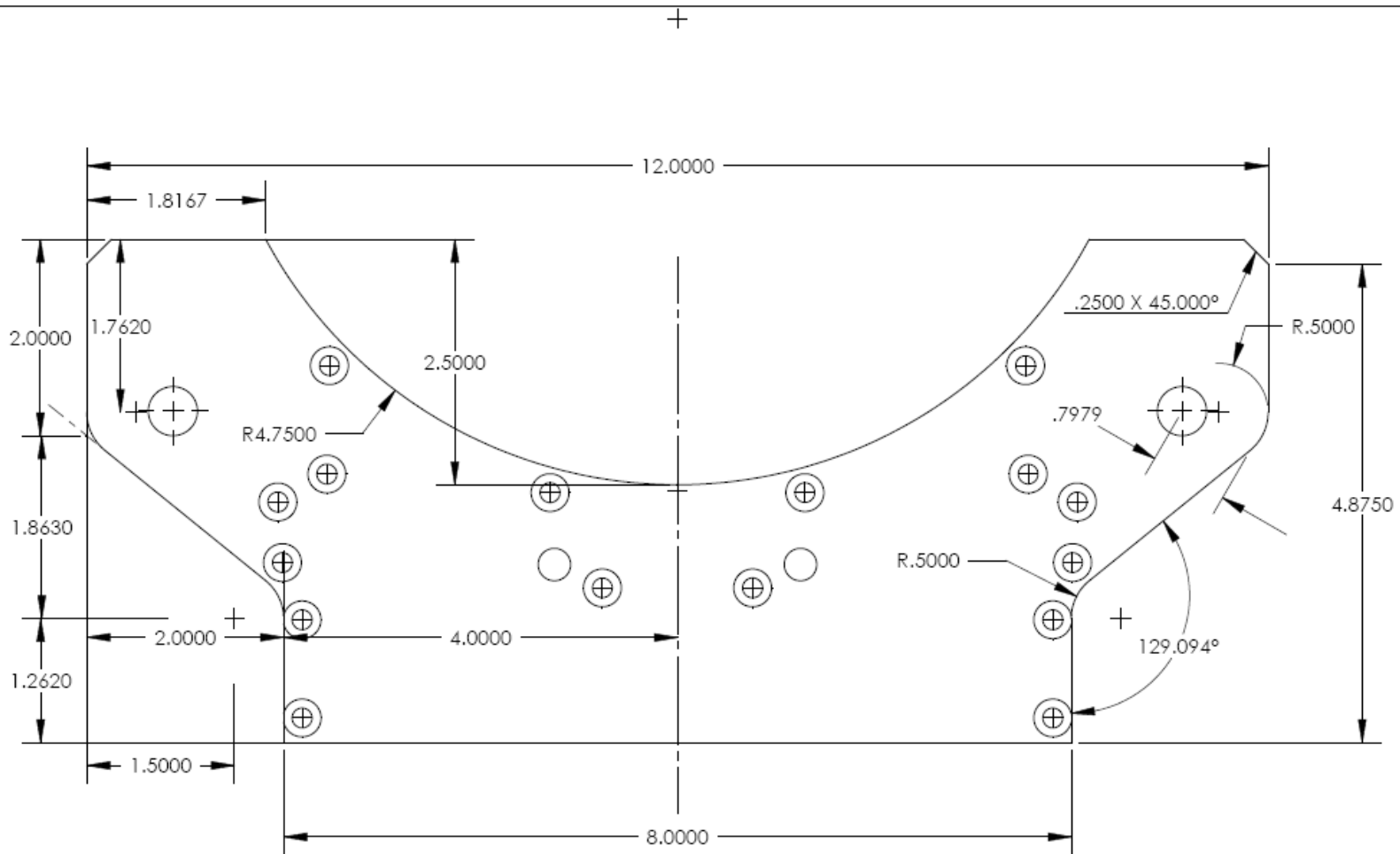

PROPRIETARY AND CONFIDENTIAL
 THE INFORMATION CONTAINED IN THIS
 DRAWING IS THE SOLE PROPERTY OF
 WORCESTER POLYTECHNIC INSTITUTE. ANY
 REPRODUCTION IN PART OR AS A WHOLE
 WITHOUT THE WRITTEN PERMISSION OF
 WPI IS PROHIBITED.

UNLESS OTHERWISE SPECIFIED:	NAME	EMAIL
DIMENSIONS ARE IN INCHES	Stephen Bergeron	stephenb@wpi.edu
TOLERANCES:	Ryan Leblanc	ryanib@wpi.edu
FRACTIONAL: ±	Gary Hamilton	wbgary@wpi.edu
ANGULAR: MACH ± BEND ±	COMMENTS:	
TWO PLACE DECIMAL ±	0.375" x 5.13" x 12"	
THREE PLACE DECIMAL ±	MATERIAL:	
	Delrin	
	STOCK THICKNESS	
	0.375" THK	

Knee MRI Enclosure Project		
TITLE:		
Side Coil Guides		
SIZE	DWG. NO.	REV
A		2
SCALE: 1:1	WEIGHT:	SHEET 2 OF 2

Knee MRI Enclosure Project		
TITLE:		
Side Coil Guides		
SIZE	DWG. NO.	REV
A		2
SCALE: 1:1	WEIGHT:	SHEET 2 OF 2

5

4

3

2

1

Hole Table- Plate Face			
TAG	X LOC	Y LOC	SIZE
A1	1.4375	1.0000	ϕ .2010 THRU ALL ✓ ϕ .3850 X 82°

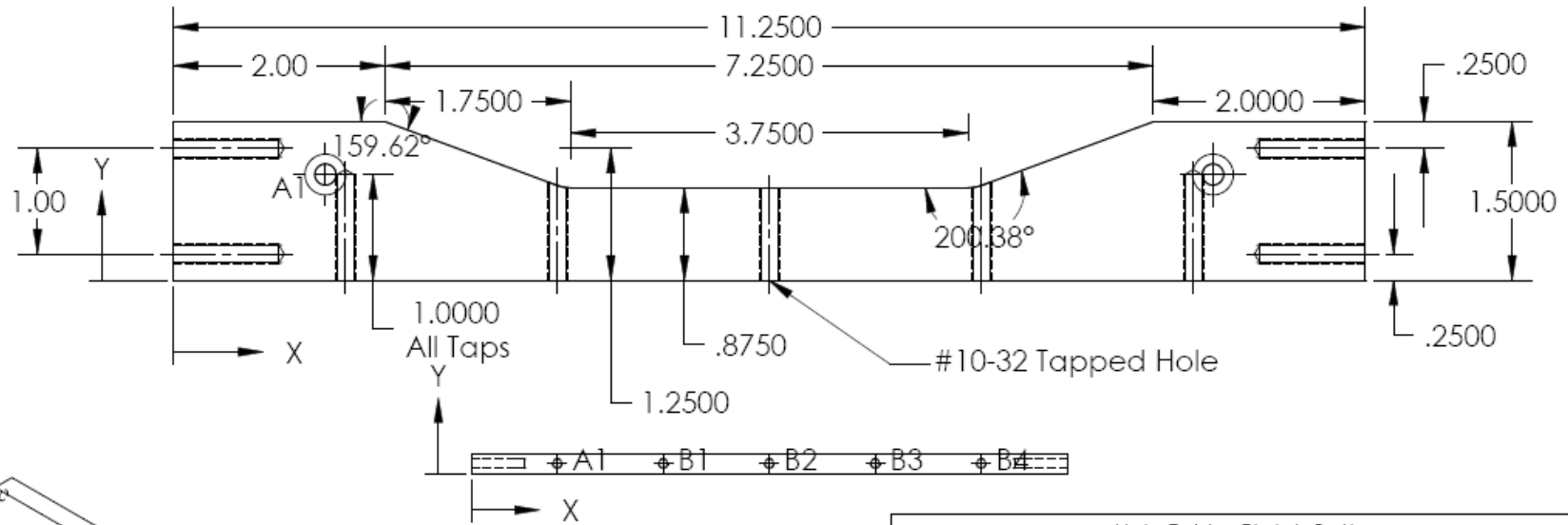

Hole Table- Plate's Bottom			
TAG	X LOC	Y LOC	SIZE
A1	1.6250	.1875	ϕ .159 ∇ 1.000 10-32 UNF - 2B ∇ .875
B1	3.6250	.1875	
B2	5.6250	.1875	
B3	7.6250	.1875	
B4	9.6250	.1875	

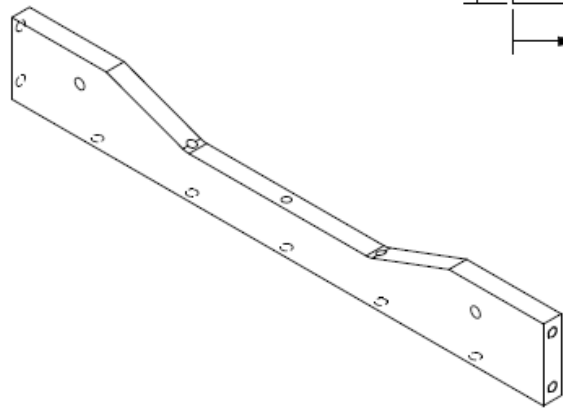

PROPRIETARY AND CONFIDENTIAL
THE INFORMATION CONTAINED IN THIS
DRAWING IS THE SOLE PROPERTY OF
WORCESTER POLYTECHNIC INSTITUTE. ANY
REPRODUCTION IN PART OR AS A WHOLE
WITHOUT THE WRITTEN PERMISSION OF
WPI IS PROHIBITED.

UNLESS OTHERWISE SPECIFIED:
DIMENSIONS ARE IN INCHES
TOLERANCES:
FRACTIONAL \pm
ANGULAR: MACH \pm BEND \pm
TWO PLACE DECIMAL \pm
THREE PLACE DECIMAL \pm
MATERIAL
Delrin
STOCK THICKNESS
0.375" THK

NAME	EMAIL
Stephen Bergeron	stephenb@wpi.edu
Ryan Leblanc	ryanlb@wpi.edu
Gary Hamilton	wbgary@wpi.edu

COMMENTS:
0.375" x 1.5" x 11.25"

Knee MRI Enclosure Project

TITLE:
Side Support

SIZE A	DWG. NO.	REV
SCALE: 1:1	WEIGHT: 0.18	SHEET 1 OF 1

5 4 3 2 1

Two Arm Components

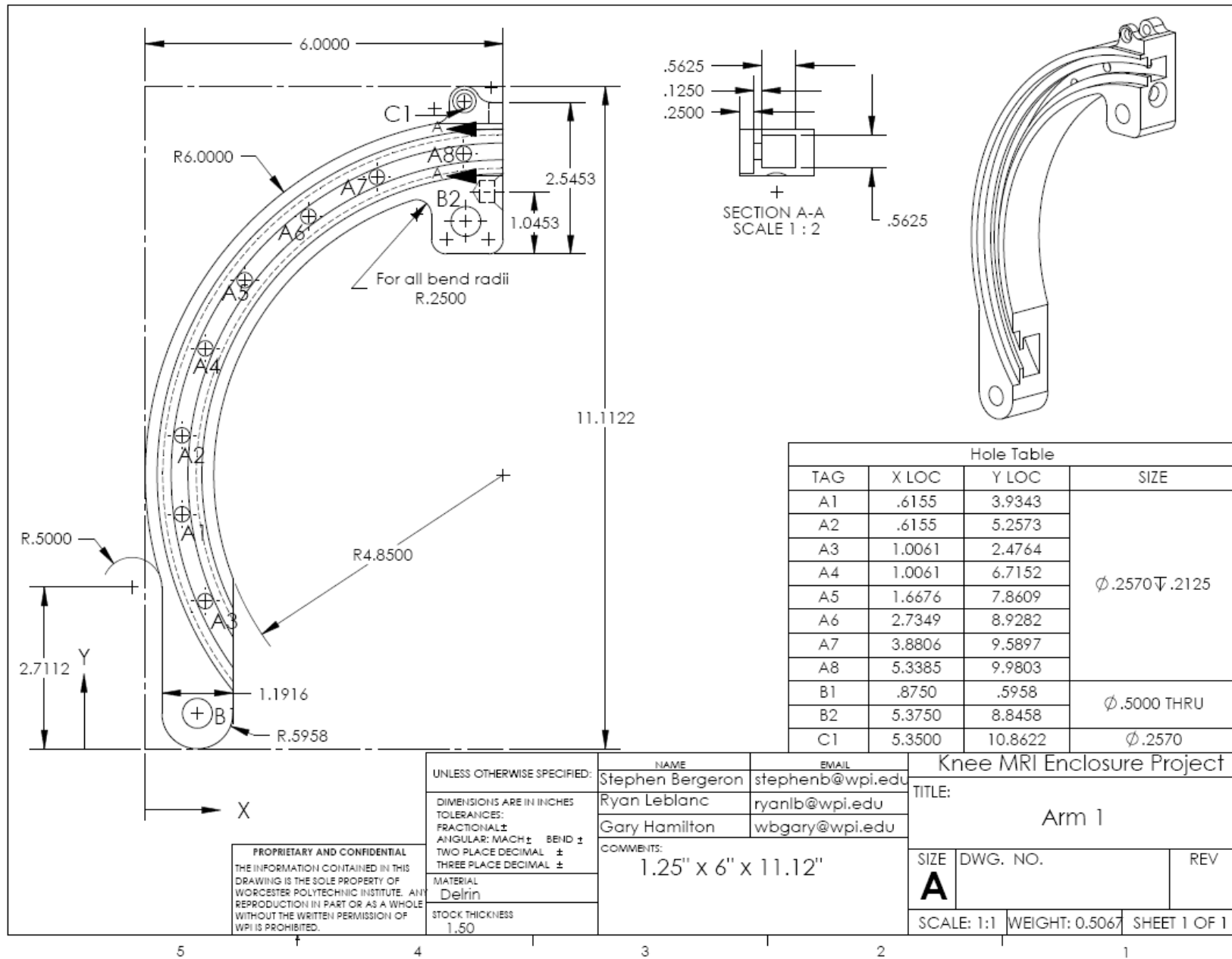

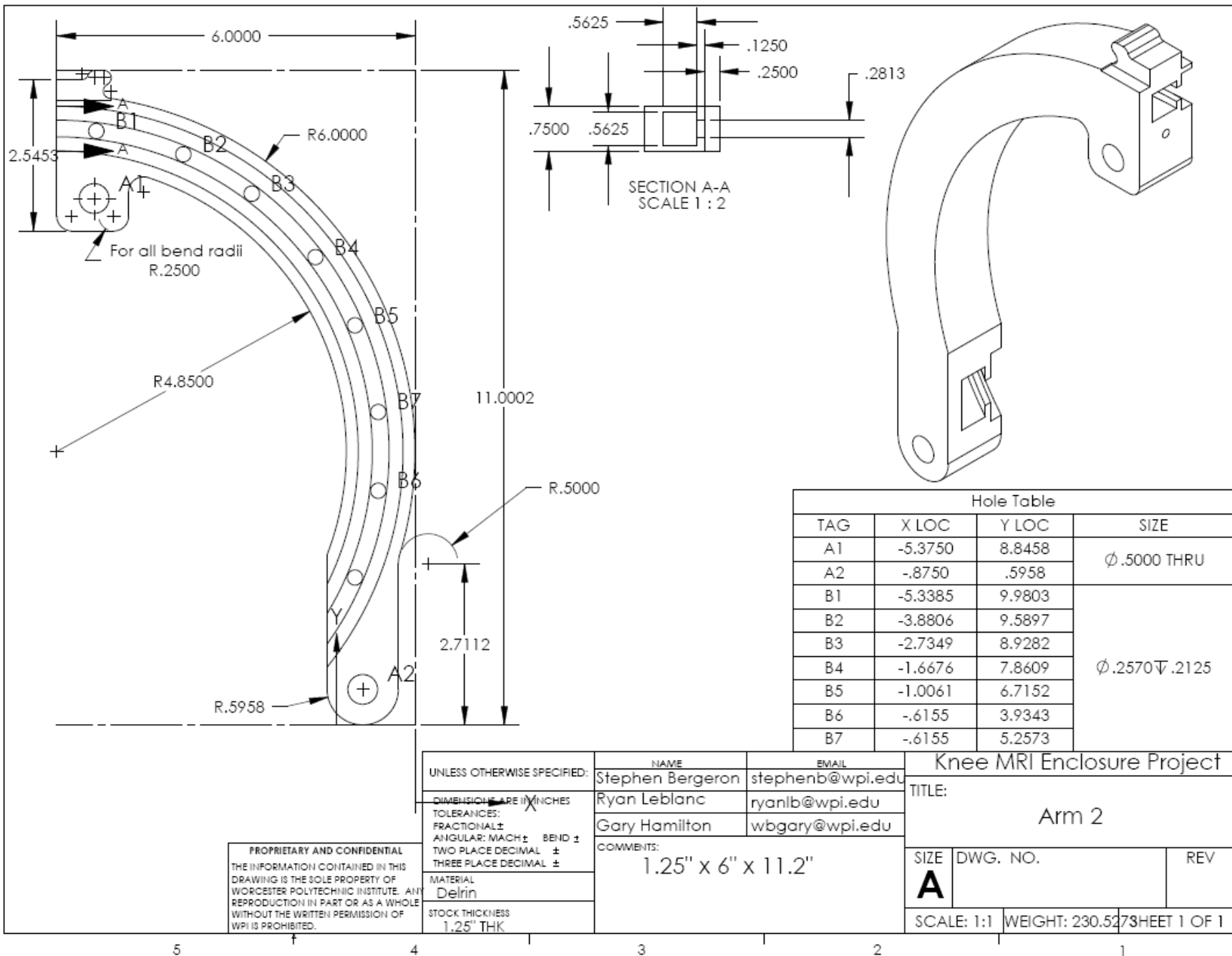

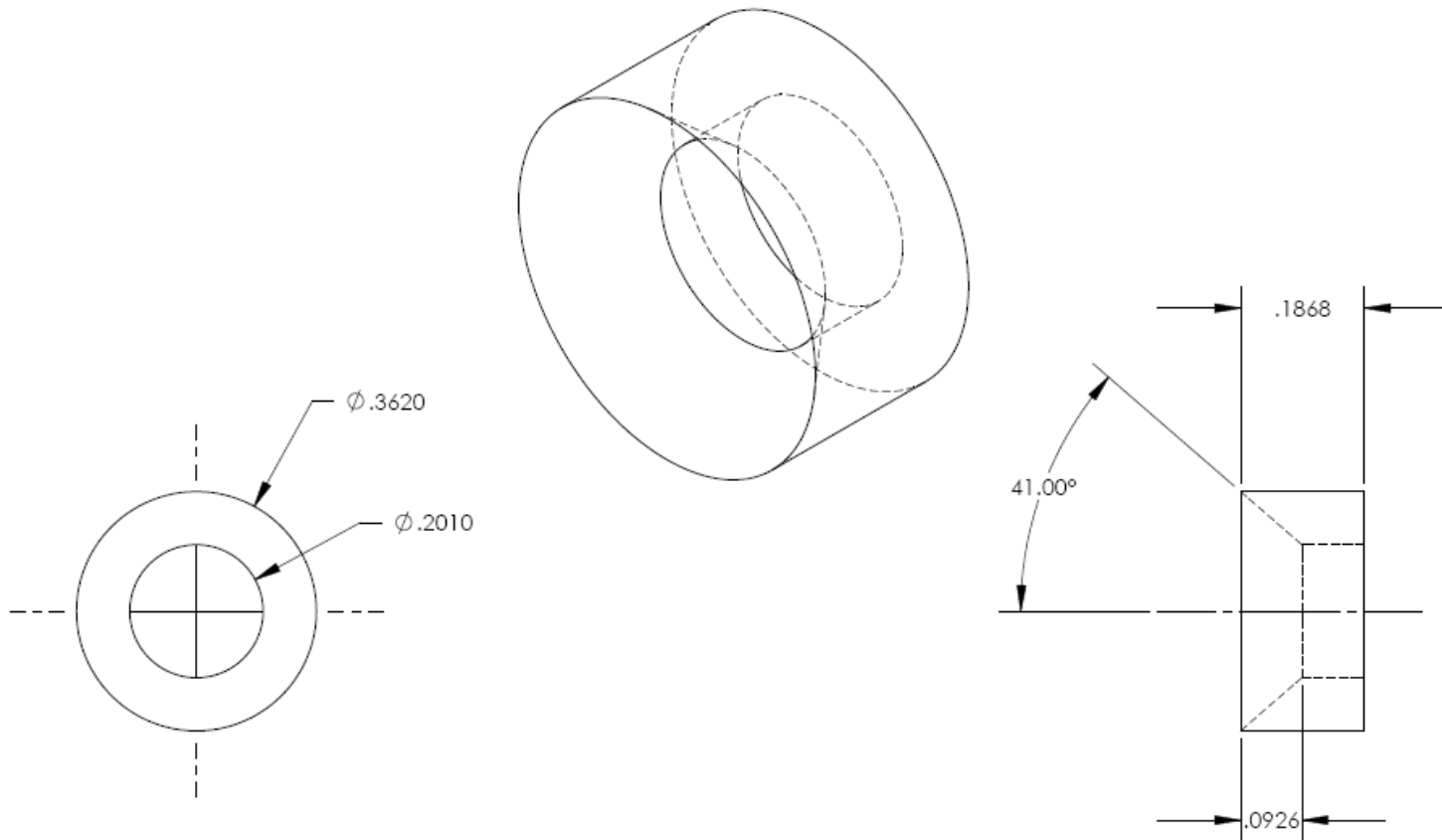

PROPRIETARY AND CONFIDENTIAL
 THE INFORMATION CONTAINED IN THIS
 DRAWING IS THE SOLE PROPERTY OF
 WORCESTER POLYTECHNIC INSTITUTE. ANY
 REPRODUCTION IN PART OR AS A WHOLE
 WITHOUT THE WRITTEN PERMISSION OF
 WPI IS PROHIBITED.

UNLESS OTHERWISE SPECIFIED: DIMENSIONS ARE IN INCHES TOLERANCES: FRACTIONAL ± ANGULAR: MACH ± BEND ± TWO PLACE DECIMAL ± THREE PLACE DECIMAL ±	NAME	EMAIL	Knee MRI Enclosure Project	
	Stephen Bergeron	stephenb@wpi.edu	TITLE: Arm Ring	
	Ryan Leblanc	ryanlb@wpi.edu	SIZE A	DWG. NO.
	Gary Hamilton	wbgary@wpi.edu		
MATERIAL Delrin	COMMENTS: 0.362" Diameter x 0.187"		REV	
STOCK THICKNESS 0.5" Diameter			SCALE: 4:1	WEIGHT: 0.00038000 SHEET 1 OF 1

5

4

3

2

1

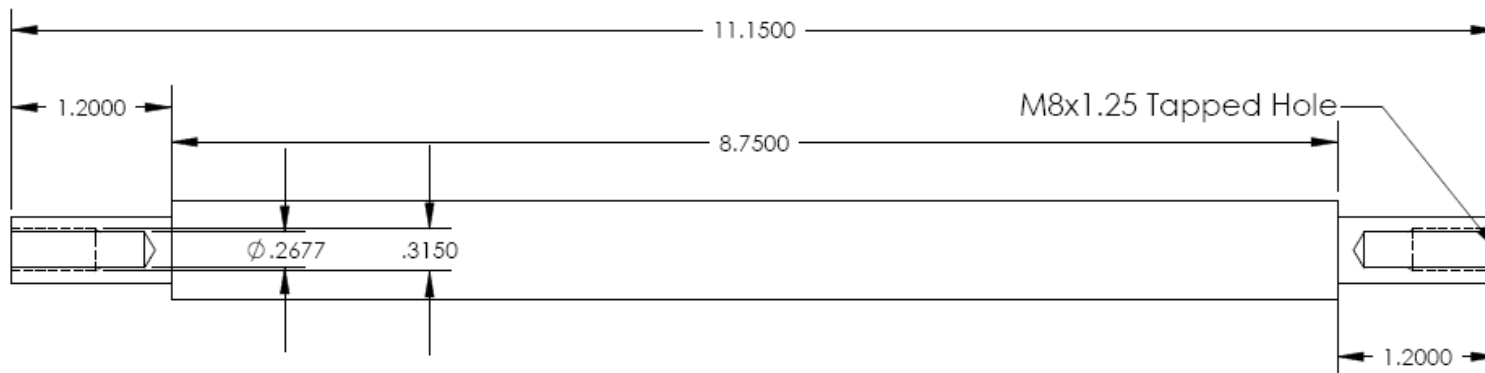
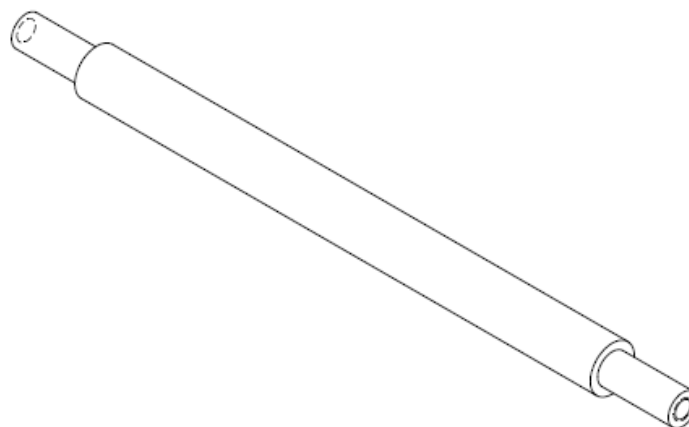
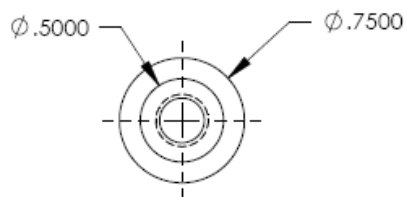

PROPRIETARY AND CONFIDENTIAL
 THE INFORMATION CONTAINED IN THIS
 DRAWING IS THE SOLE PROPERTY OF
 WORCESTER POLYTECHNIC INSTITUTE. ANY
 REPRODUCTION IN PART OR AS A WHOLE
 WITHOUT THE WRITTEN PERMISSION OF
 WPI IS PROHIBITED.

UNLESS OTHERWISE SPECIFIED: DIMENSIONS ARE IN INCHES TOLERANCES: FRACTIONAL ± ANGULAR: MACH ± BEND ± TWO PLACE DECIMAL ± THREE PLACE DECIMAL ± MATERIAL Delrin STOCK THICKNESS 0.75" Diameter	NAME	EMAIL	Knee MRI Enclosure Project	
	Stephen Bergeron	stephenb@wpi.edu	TITLE: Brace Rod	
	Ryan Leblanc	ryanlb@wpi.edu	SIZE	DWG. NO.
	Gary Hamilton	wbgary@wpi.edu	A	REV
	COMMENTS: 0.75" Diameter x 11.15"		SCALE: 1:1	WEIGHT:
				SHEET 1 OF 1

5

4

3

2

1

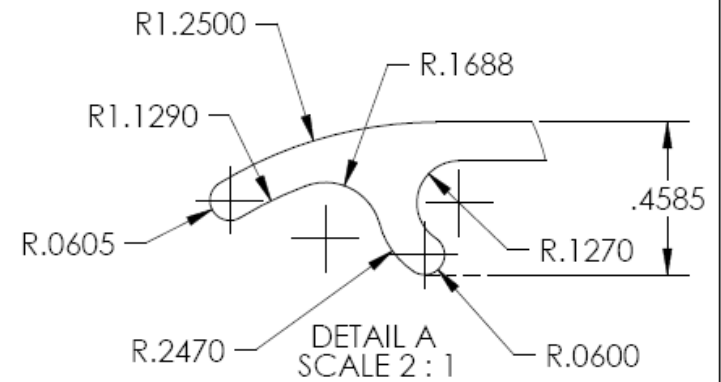
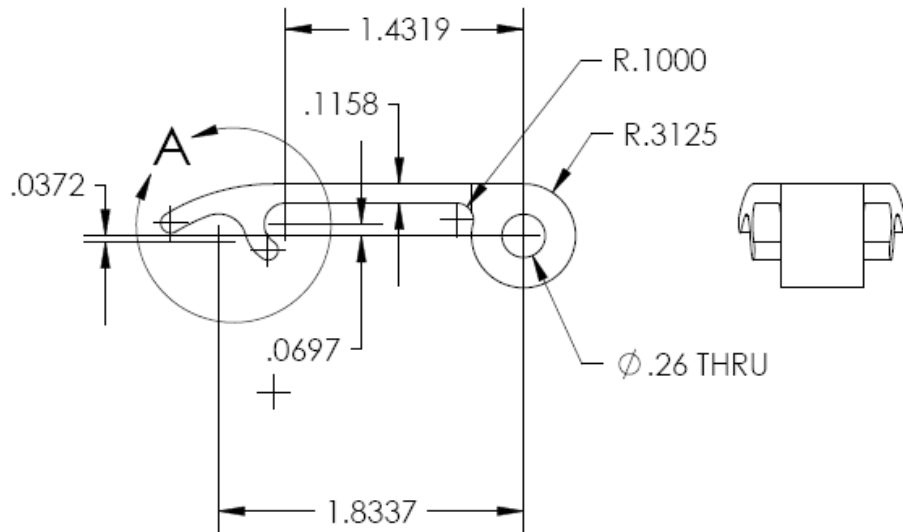
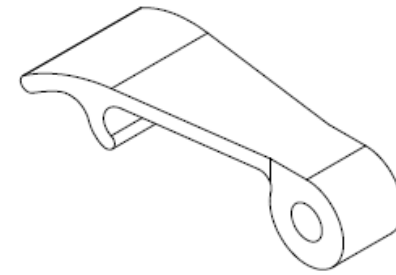
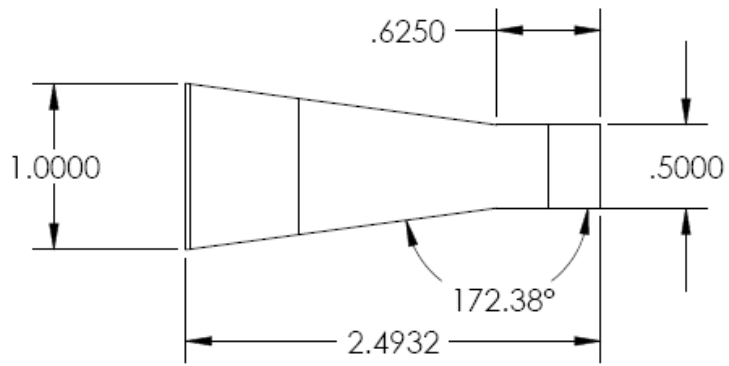

PROPRIETARY AND CONFIDENTIAL
 THE INFORMATION CONTAINED IN THIS
 DRAWING IS THE SOLE PROPERTY OF
 WORCESTER POLYTECHNIC INSTITUTE. AN
 REPRODUCTION IN PART OR AS A WHOLE
 WITHOUT THE WRITTEN PERMISSION OF
 WPI IS PROHIBITED.

UNLESS OTHERWISE SPECIFIED:	NAME	EMAIL
DIMENSIONS ARE IN INCHES	Stephen Bergeron	stephenb@wpi.edu
TOLERANCES:	Ryan Leblanc	ryanib@wpi.edu
FRACTIONAL: \pm	Gary Hamilton	wbgary@wpi.edu
ANGULAR: MACH \pm BEND \pm	COMMENTS:	
TWO PLACE DECIMAL \pm	0.62" x 1" x 2.5"	
THREE PLACE DECIMAL \pm		
MATERIAL		
Delrin		
STOCK THICKNESS		
1.0" THK		

Knee MRI Enclosure Project		
TITLE:		
Clamp Hook		
SIZE	DWG. NO.	REV
A		
SCALE: 1:1	WEIGHT:	SHEET 1 OF 1

5	4	3	2	1
---	---	---	---	---

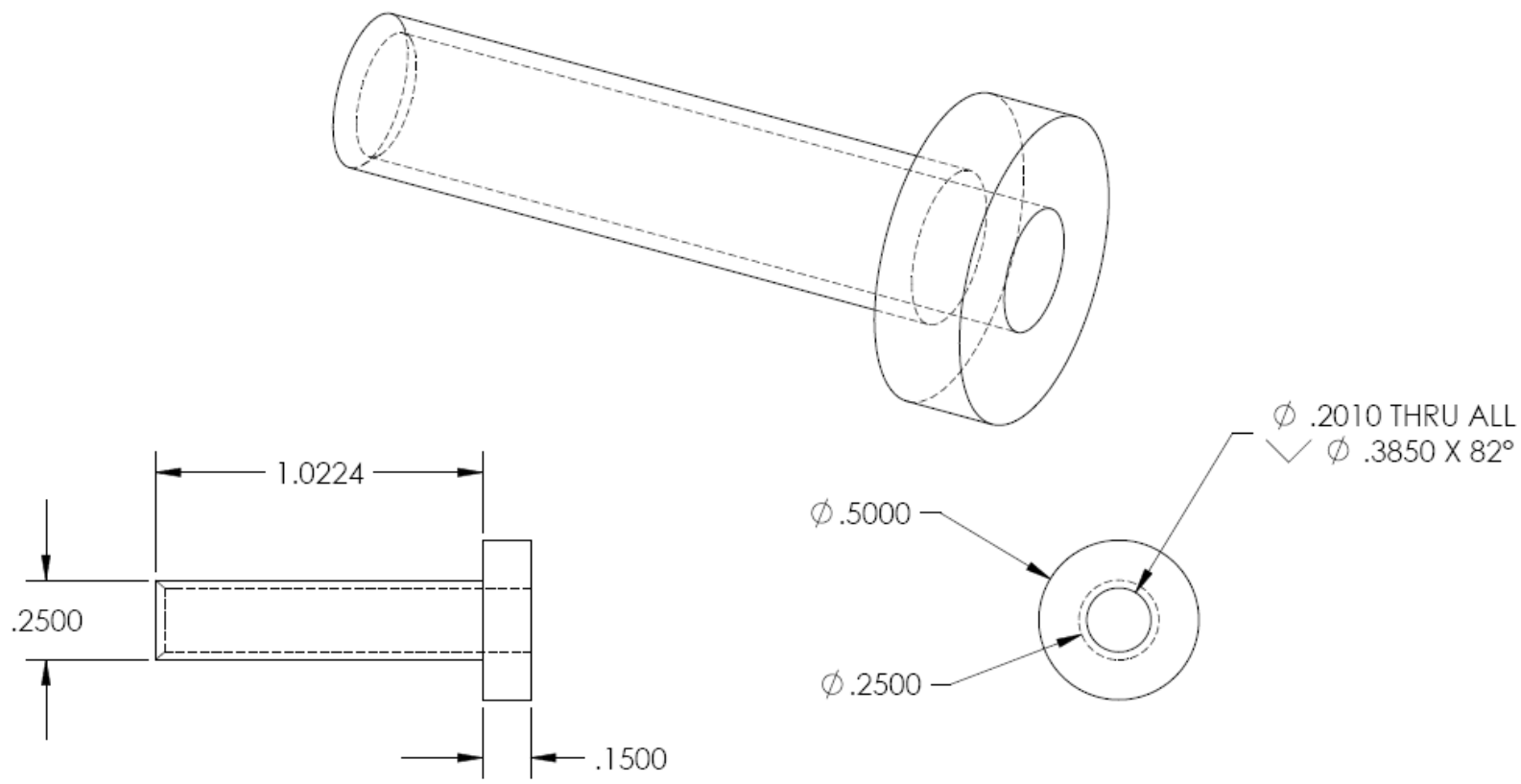

PROPRIETARY AND CONFIDENTIAL
 THE INFORMATION CONTAINED IN THIS
 DRAWING IS THE SOLE PROPERTY OF
 WORCESTER POLYTECHNIC INSTITUTE. AN
 REPRODUCTION IN PART OR AS A WHOLE
 WITHOUT THE WRITTEN PERMISSION OF
 WPI IS PROHIBITED.

UNLESS OTHERWISE SPECIFIED: DIMENSIONS ARE IN INCHES TOLERANCES: FRACTIONAL: ± ANGULAR: MACH ± BEND ± TWO PLACE DECIMAL ± THREE PLACE DECIMAL ±	NAME	EMAIL	Knee MRI Enclosure Project		
	Stephen Bergeron	stephenb@wpi.edu	TITLE:		
	Ryan Leblanc	ryanib@wpi.edu	Clamp Pin		
	Gary Hamilton	wbgary@wpi.edu	SIZE	DWG. NO.	REV
MATERIAL	COMMENTS:		SCALE: 2:1	WEIGHT: 0.00	SHEET 1 OF 1
Delrin	0.75" Diameter x 1.25"				
STOCK THICKNESS					
0.75" Diameter					

5 4 3 2 1

RF Coil Enclosure Components

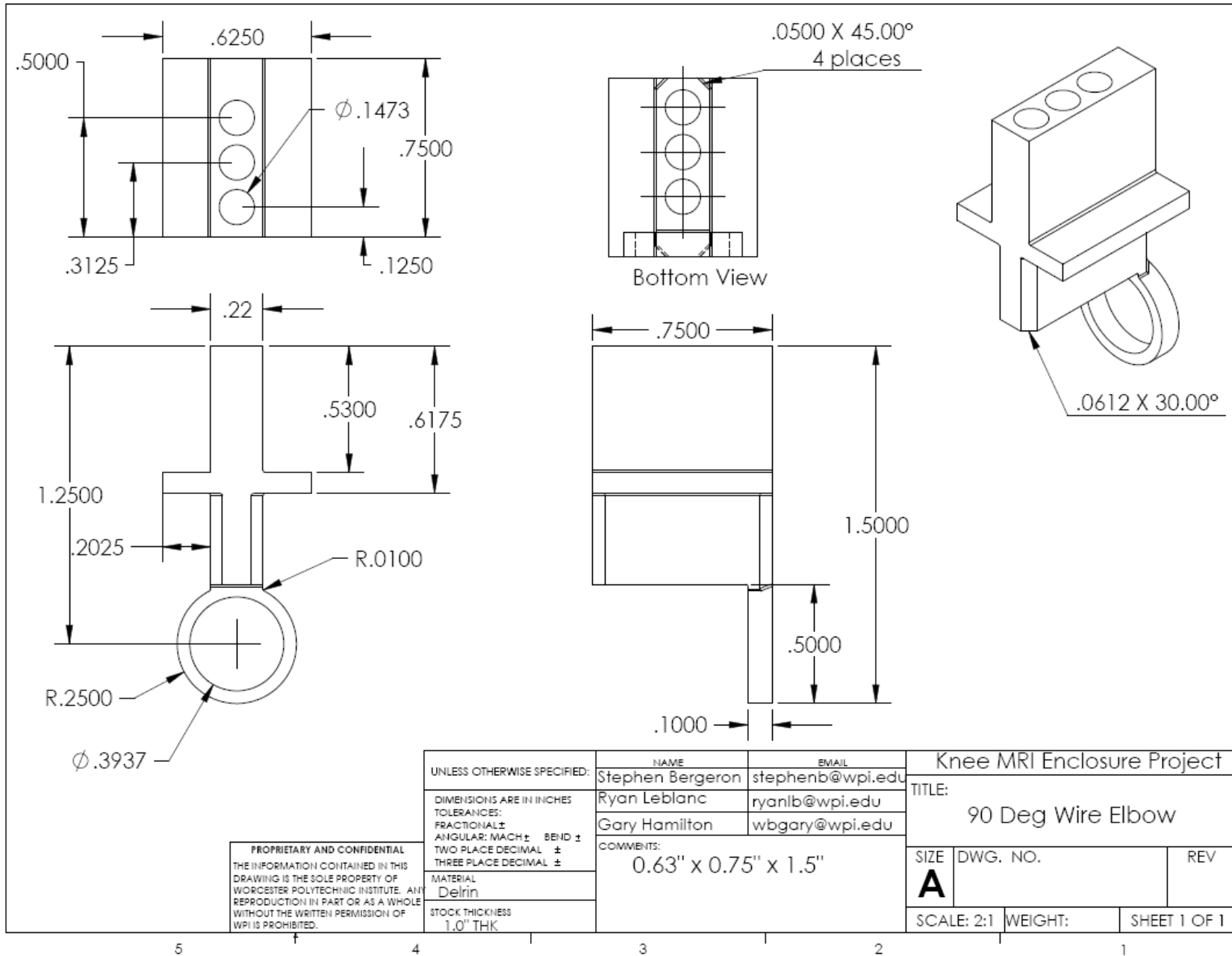

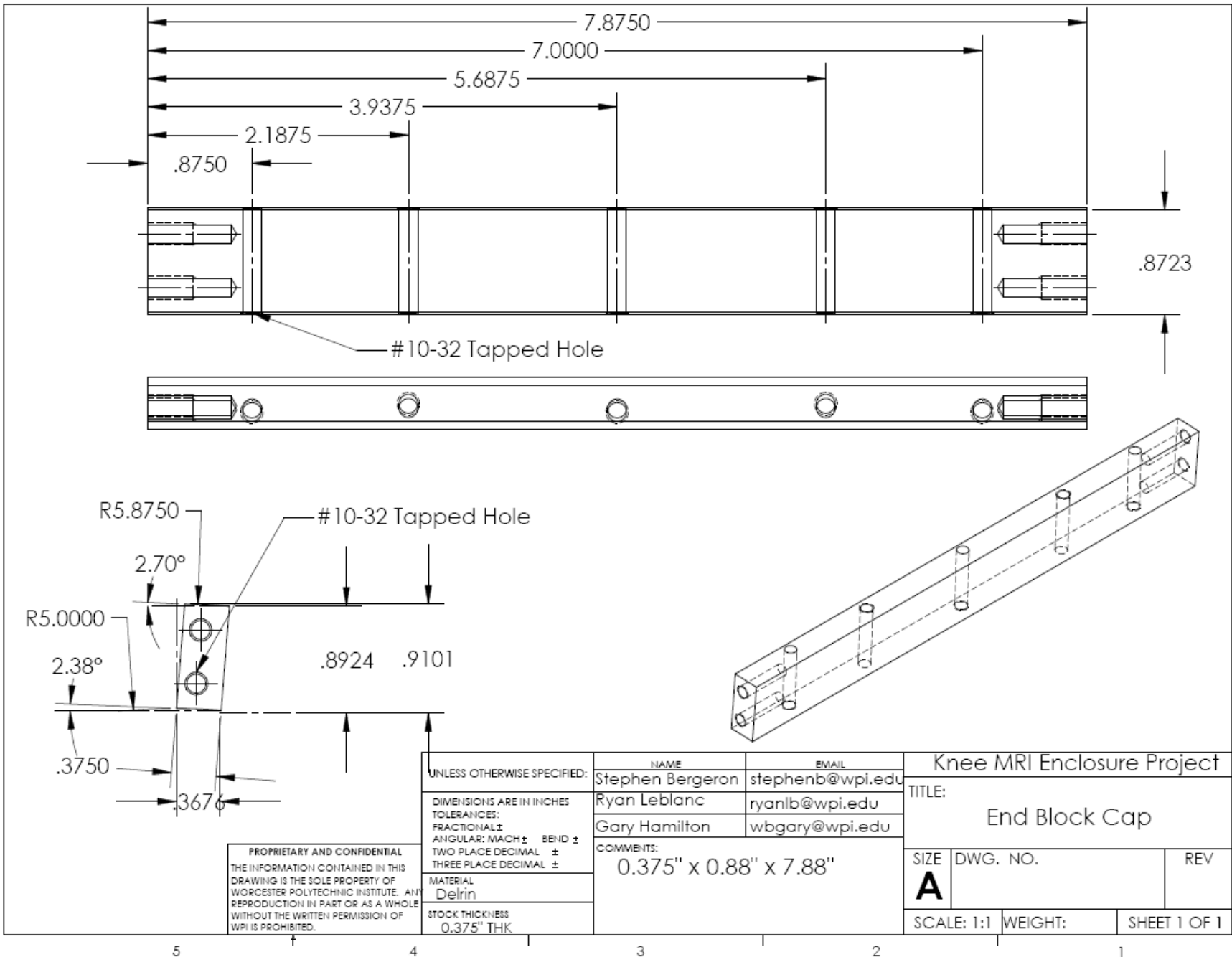

PROPRIETARY AND CONFIDENTIAL
 THE INFORMATION CONTAINED IN THIS
 DRAWING IS THE SOLE PROPERTY OF
 WORCESTER POLYTECHNIC INSTITUTE. ANY
 REPRODUCTION IN PART OR AS A WHOLE
 WITHOUT THE WRITTEN PERMISSION OF
 WPI IS PROHIBITED.

UNLESS OTHERWISE SPECIFIED:
 DIMENSIONS ARE IN INCHES
 TOLERANCES:
 FRACTIONAL: ±
 ANGULAR: MACH ± BEND ±
 TWO PLACE DECIMAL ±
 THREE PLACE DECIMAL ±
 MATERIAL
 Delrin
 STOCK THICKNESS
 0.375" THK

NAME	EMAIL
Stephen Bergeron	stephenb@wpi.edu
Ryan Leblanc	ryanlb@wpi.edu
Gary Hamilton	wbgary@wpi.edu

COMMENTS:
 0.375" x 0.88" x 7.88"

Knee MRI Enclosure Project		
TITLE: End Block Cap		
SIZE A	DWG. NO.	REV
SCALE: 1:1	WEIGHT:	SHEET 1 OF 1

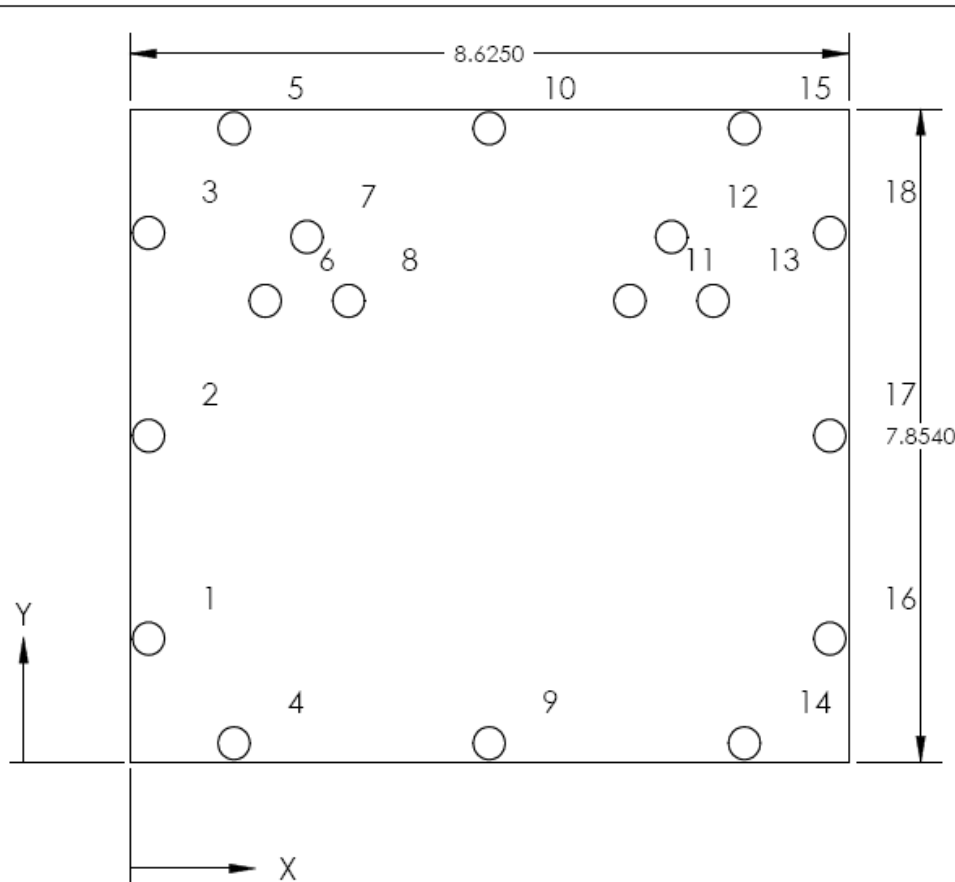

Hole Table			
TAG	X LOC	Y LOC	Size
1	.2250	1.4886	ϕ .2010 THRU ALL \surd ϕ .3850 x 82°
2	.2250	3.9270	
3	.2250	6.3654	
4	1.2500	.2309	
5	1.2500	7.6231	
6	1.6250	5.5488	
7	2.1250	6.3171	
8	2.6250	5.5488	
9	4.3125	.2309	
10	4.3125	7.6231	
11	6.0000	5.5488	
12	6.5000	6.3171	
13	7.0000	5.5488	
14	7.3750	.2309	
15	7.3750	7.6231	
16	8.4000	1.4886	
17	8.4000	3.9270	
18	8.4000	6.3654	

Although not shown, treat all holes as:
 ϕ .2010 THRU ALL \surd ϕ .3850 x 82°

PROPRIETARY AND CONFIDENTIAL
 THE INFORMATION CONTAINED IN THIS
 DRAWING IS THE SOLE PROPERTY OF
 WORCESTER POLYTECHNIC INSTITUTE. ANY
 REPRODUCTION IN PART OR AS A WHOLE
 WITHOUT THE WRITTEN PERMISSION OF
 WPI IS PROHIBITED.

UNLESS OTHERWISE SPECIFIED:
 DIMENSIONS ARE IN INCHES
 TOLERANCES:
 FRACTIONAL \pm
 ANGULAR: MACH \pm BEND \pm
 TWO PLACE DECIMAL \pm
 THREE PLACE DECIMAL \pm
 MATERIAL
 Polycarbonate
 STOCK THICKNESS
 0.125" THK

NAME	EMAIL
Stephen Bergeron	stephenb@wpi.edu
Ryan Leblanc	ryanlb@wpi.edu
Gary Hamilton	wbgary@wpi.edu

COMMENTS:
 0.125" x 7.85" x 8.63"

Knee MRI Enclosure Project		
TITLE: Inner Cover Unbent		
SIZE A	DWG. NO.	REV
SCALE: 1:1	WEIGHT:	SHEET 1 OF 1

5 4 3 2 1

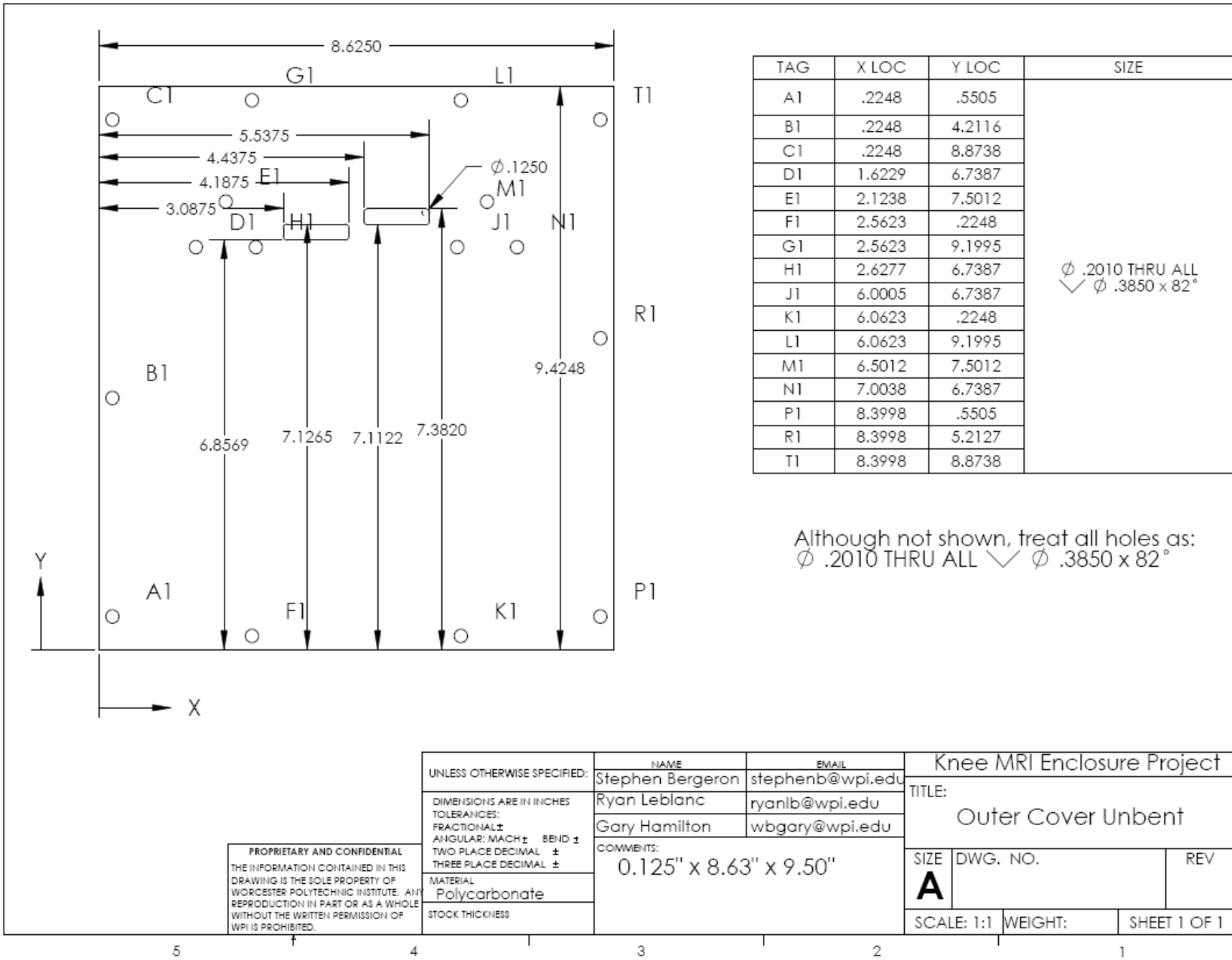

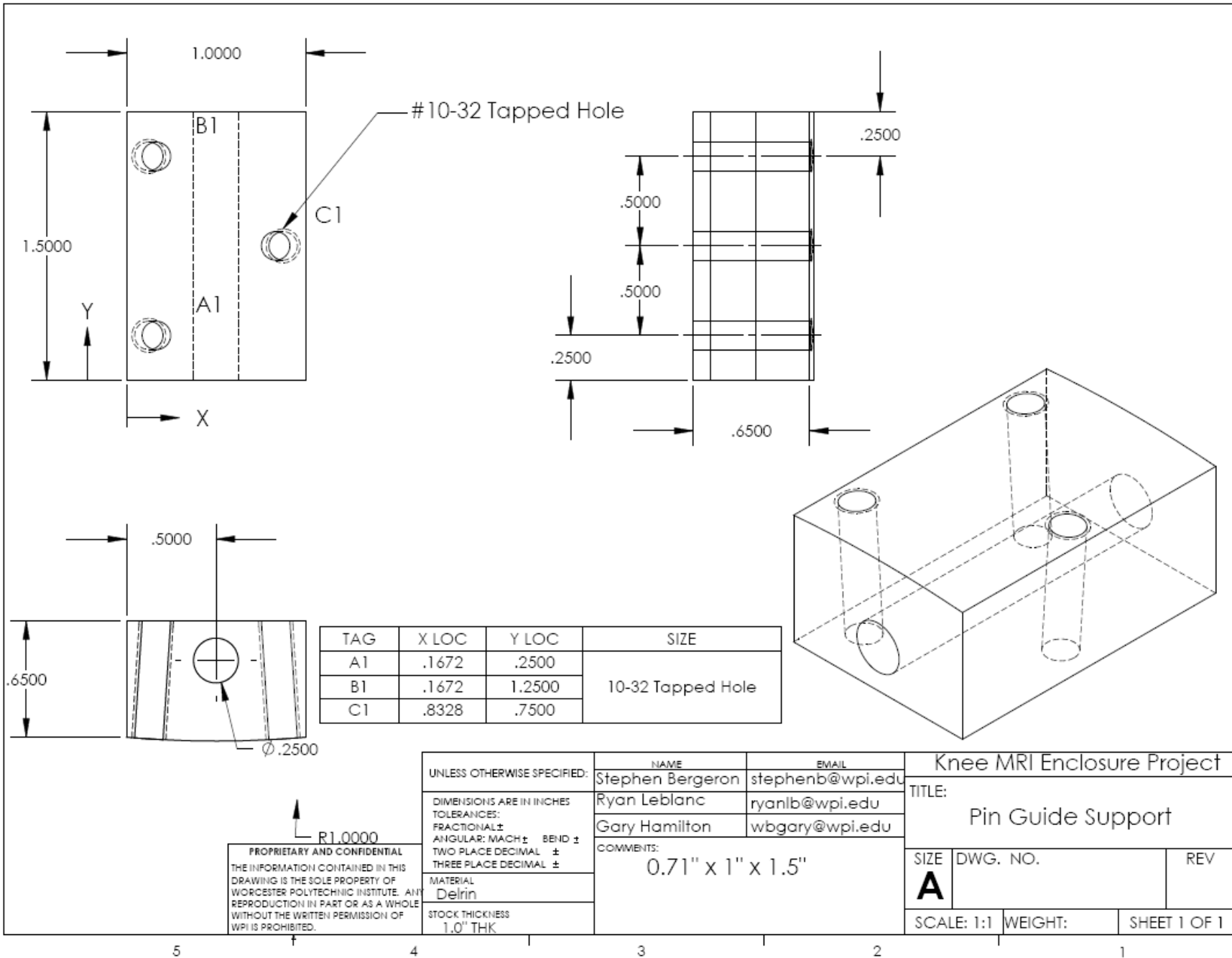

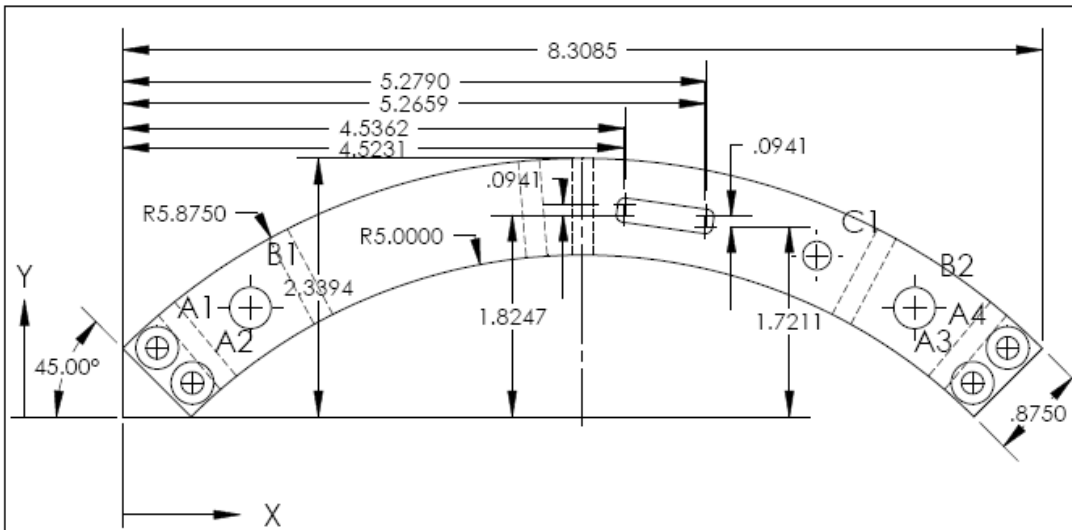

Hole Table			
TAG	X LOC	Y LOC	SIZE
A1	.3128	.6241	ϕ .2010 THRU ALL \checkmark ϕ .3850 X 82°
A2	.6310	.3059	
A3	7.6775	.3059	
A4	7.9957	.6241	
B1	1.1543	.9845	ϕ .3750 THRU
B2	7.1543	.9845	
C1	6.2736	1.4583	ϕ .2570 THRU

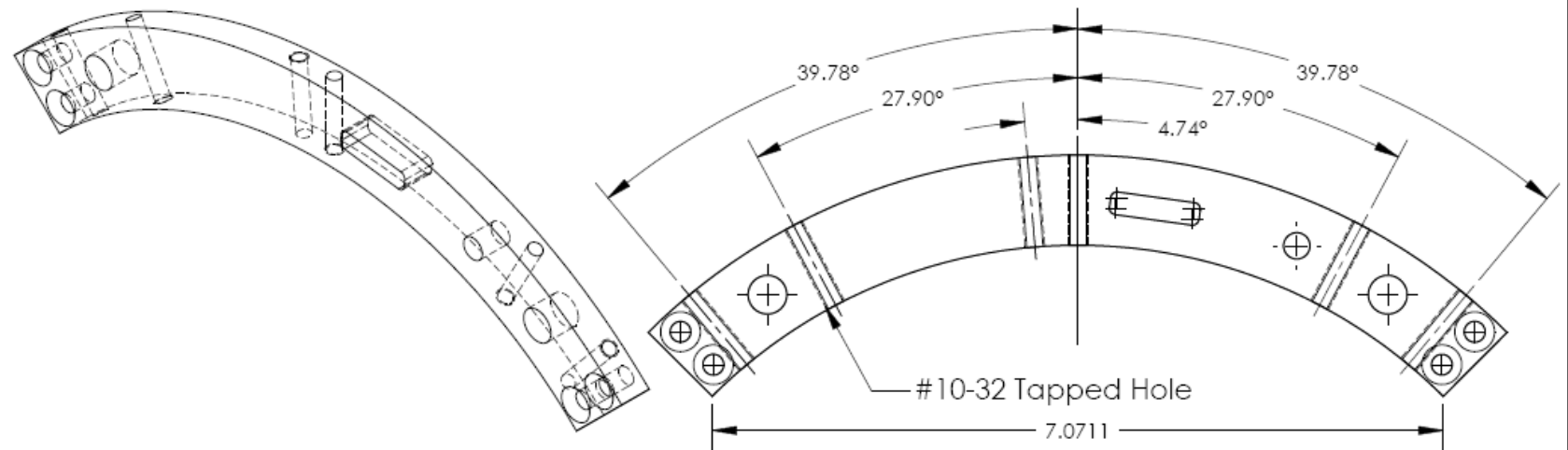

PROPRIETARY AND CONFIDENTIAL
 THE INFORMATION CONTAINED IN THIS
 DRAWING IS THE SOLE PROPERTY OF
 WORCESTER POLYTECHNIC INSTITUTE. ANY
 REPRODUCTION IN PART OR AS A WHOLE
 WITHOUT THE WRITTEN PERMISSION OF
 WPI IS PROHIBITED.

UNLESS OTHERWISE SPECIFIED: DIMENSIONS ARE IN INCHES TOLERANCES: FRACTIONAL: ± ANGULAR: MACH ± BEND ± TWO PLACE DECIMAL ± THREE PLACE DECIMAL ± MATERIAL Delrin STOCK THICKNESS 0.375" THK	NAME	EMAIL	Knee MRI Enclosure Project	
	Stephen Bergeron	stephenb@wpi.edu	TITLE:	
	Ryan Leblanc	ryanlb@wpi.edu	Side Plate Left	
	Gary Hamilton	wbgary@wpi.edu	SIZE	DWG. NO.
COMMENTS: 0.375" x 3.54" x 8.4"			SCALE: 1:1	
			WEIGHT:	SHEET 1 OF 1

5 4 3 2 1

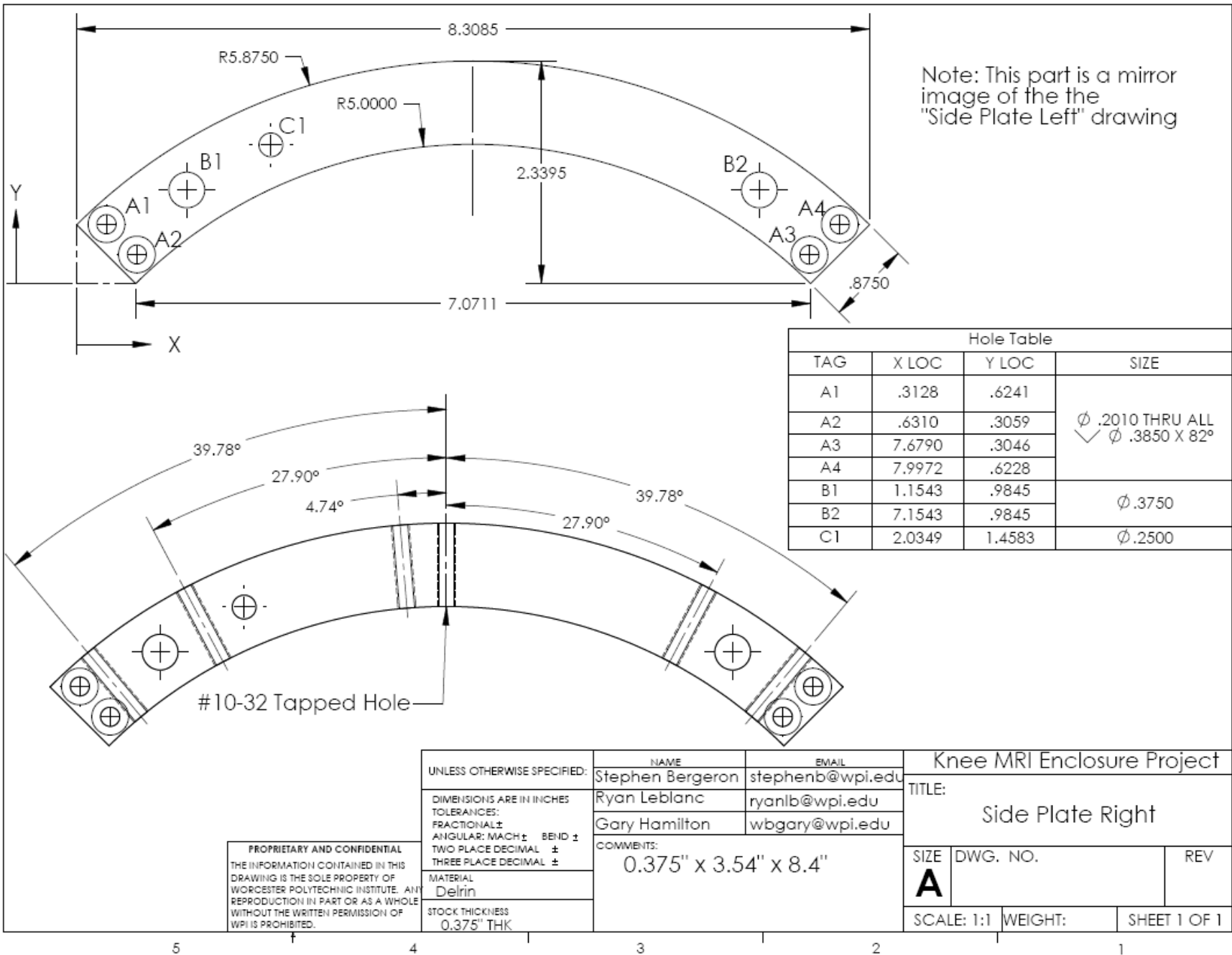

PROPRIETARY AND CONFIDENTIAL
 THE INFORMATION CONTAINED IN THIS
 DRAWING IS THE SOLE PROPERTY OF
 WORCESTER POLYTECHNIC INSTITUTE. ANY
 REPRODUCTION IN PART OR AS A WHOLE
 WITHOUT THE WRITTEN PERMISSION OF
 WPI IS PROHIBITED.

UNLESS OTHERWISE SPECIFIED:
 DIMENSIONS ARE IN INCHES
 TOLERANCES:
 FRACTIONAL: ±
 ANGULAR: MACH ± BEND ±
 TWO PLACE DECIMAL ±
 THREE PLACE DECIMAL ±
 MATERIAL
 Delrin
 STOCK THICKNESS
 0.375" THK

NAME	EMAIL
Stephen Bergeron	stephenb@wpi.edu
Ryan Leblanc	ryanlb@wpi.edu
Gary Hamilton	wbgary@wpi.edu

COMMENTS:
 0.375" x 3.54" x 8.4"

Knee MRI Enclosure Project

TITLE:
 Side Plate Right

SIZE	DWG. NO.	REV
A		
SCALE: 1:1	WEIGHT:	SHEET 1 OF 1

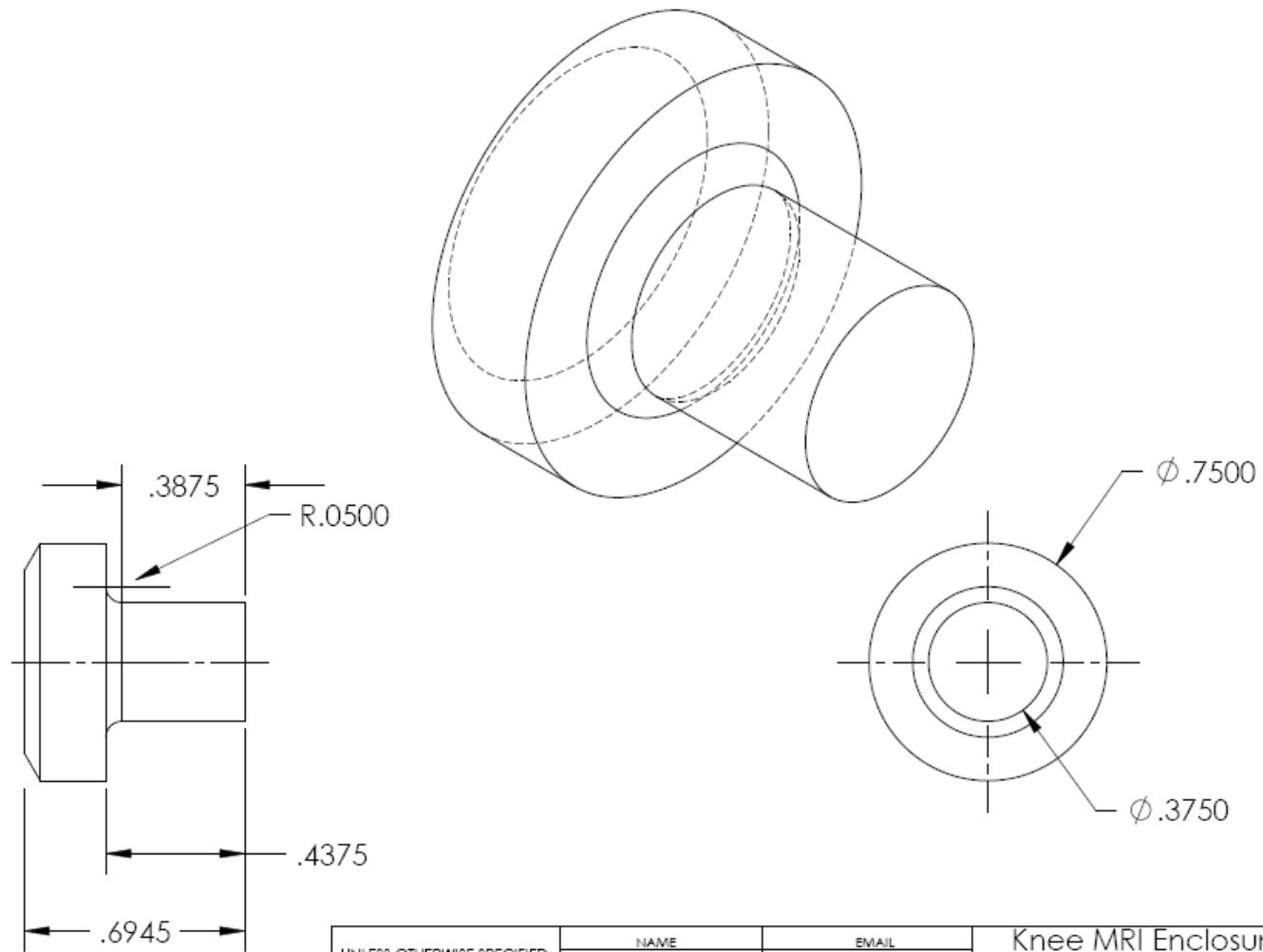

PROPRIETARY AND CONFIDENTIAL
 THE INFORMATION CONTAINED IN THIS
 DRAWING IS THE SOLE PROPERTY OF
 WORCESTER POLYTECHNIC INSTITUTE. ANY
 REPRODUCTION IN PART OR AS A WHOLE
 WITHOUT THE WRITTEN PERMISSION OF
 WPI IS PROHIBITED.

UNLESS OTHERWISE SPECIFIED: DIMENSIONS ARE IN INCHES TOLERANCES: FRACTIONAL ± ANGULAR: MACH ± BEND ± TWO PLACE DECIMAL ± THREE PLACE DECIMAL ±	NAME	EMAIL	Knee MRI Enclosure Project	
	Stephen Bergeron	stephenb@wpi.edu	TITLE:	
	Ryan Leblanc	ryanib@wpi.edu	Stand-Off Bearing	
	Gary Hamilton	wbgary@wpi.edu	SIZE	DWG. NO.
MATERIAL	COMMENTS:		REV	
Delrin	0.75" Diameter x 0.75"		A	
STOCK THICKNESS			SCALE: 2:1	WEIGHT: 0.0058 15 SHEET 1 OF 1
0.75" Diameter				

5

4

3

2

1

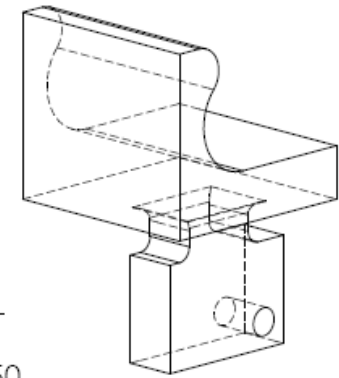
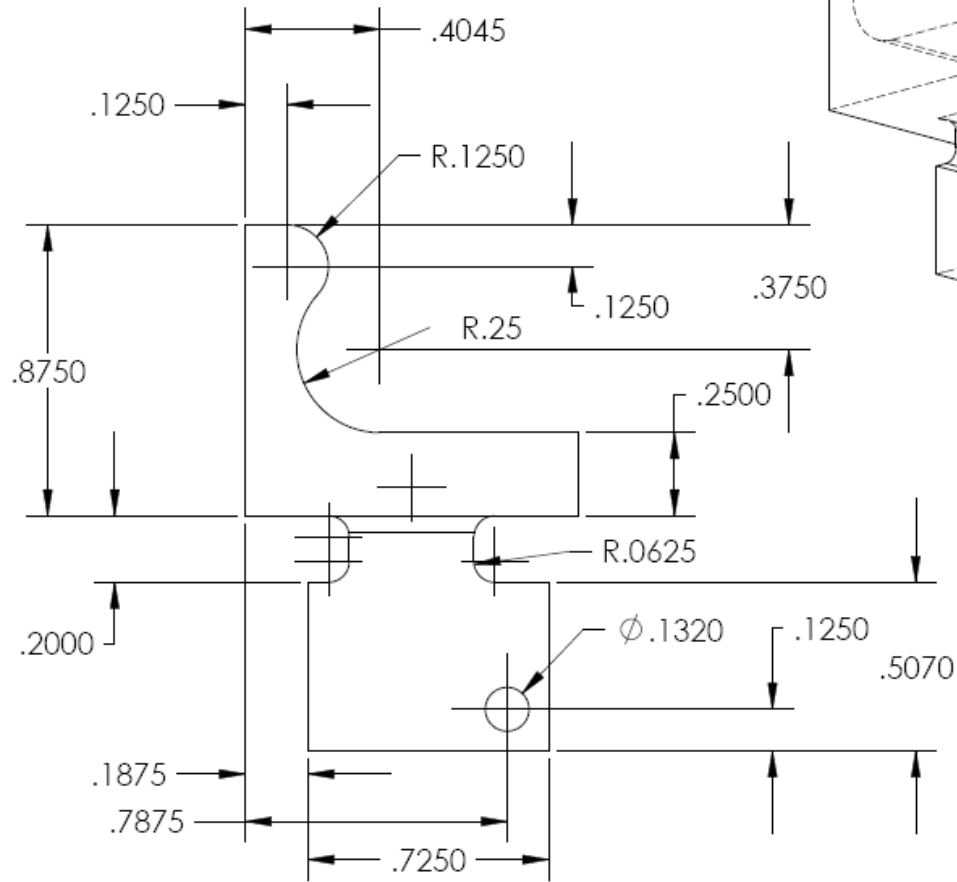
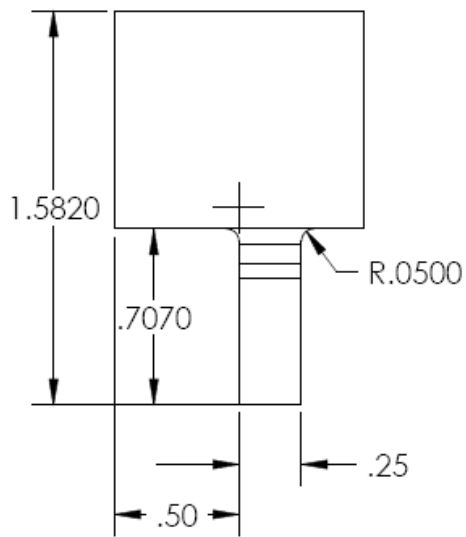
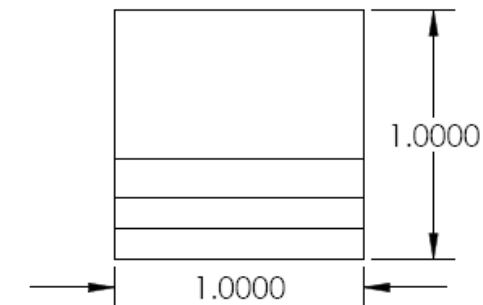

PROPRIETARY AND CONFIDENTIAL
 THE INFORMATION CONTAINED IN THIS
 DRAWING IS THE SOLE PROPERTY OF
 WORCESTER POLYTECHNIC INSTITUTE. ANY
 REPRODUCTION IN PART OR AS A WHOLE
 WITHOUT THE WRITTEN PERMISSION OF
 WPI IS PROHIBITED.

UNLESS OTHERWISE SPECIFIED:
 DIMENSIONS ARE IN INCHES
 TOLERANCES:
 FRACTIONAL: ±
 ANGULAR: MACH ± BEND ±
 TWO PLACE DECIMAL ±
 THREE PLACE DECIMAL ±
 MATERIAL
 Delrin
 STOCK THICKNESS
 1" THK

NAME	EMAIL
Stephen Bergeron	stephenb@wpi.edu
Ryan Leblanc	ryanlb@wpi.edu
Gary Hamilton	wbgary@wpi.edu
COMMENTS: 1" x 1" x 1.6"	

Knee MRI Enclosure Project		
TITLE: Thumb Release Tabs		
SIZE A	DWG. NO.	REV
SCALE: 1:1	WEIGHT:	SHEET 1 OF 1

5

4

3

2

1

Master Parts List

Assembly Hierarchy

Assembly Number	Part / Assembly Name	Quantity	Material	Stock Description	Minimum Stock Thickness
1	Base Clamp	1			
	Table Rail	2	Delrin	1.5" x 1.5" x 18.5"	1.5" THK SQ
	Connector 2	1	Delrin	15.2" x 4" x 0.375"	0.375" THK
	Connector 1	1	Delrin	15.2" x 4" x 0.375"	0.375" THK
	Under Hook	4	Delrin	3.25" x 3" x 1.5"	1.5" THK
	Thumb Screw (Sub Assembly)	4			
	Thumb Screw	1	Nylon 6/10	1.5" Diameter x 0.6"	Purchased
Socket Head Cap	1	Nylon 6/10	Socket Head Cap 0.375-16 x 1.25	Purchased	
2	Base	1			
	Base Plate	1	Delrin	0.25" x 8" x 12"	0.25" THK
	Side Coil Guides	2	Delrin	0.375" x 5.13" x 12"	0.375" THK
	Side Support	2	Delrin	0.375" x 1.5" x 11.25"	0.375" THK
	Wire Coil Divider	2	Delrin	0.375" x 0.75" x 7.25"	0.375" THK
	Electronic Cover Outer Support	2	Delrin	0.375" x 0.75" x 5.25"	0.375" THK
	Electronic Cover	1	Polycarbonate	0.125" x 7.25" x 8.75"	0.125" THK
	Arm Support 1	2	Delrin	0.375" x 2.6" x 3.63"	0.375" THK
	Arm Support 2	2	Delrin	0.375" x 2.6" x 3.62"	0.375" THK
	Arm Support Standoff	4	Delrin	1.08" x 1.25" x 1.75"	1.5" THK
	Base Arm Pin	4	Delrin	0.75" to 0.5" Diameter x 2.15"	0.75" Diameter
	Base Arm Cover	4	Delrin	0.75" Diameter x 0.15"	0.75" Diameter
	Guide Rail	2	Delrin	1.25" x 4.3" x 9.1"	1.5" THK
	Base Bracket	2	Delrin	4.0" x 1.65" x 1.5"	1.5" THK
	Thumb Screw (Sub Assembly)	2			
Thumb Screw	1	Nylon 6/10	1.5" Diameter x 0.6"	Purchased	
Socket Head Cap	1	Nylon 6/10	Socket Head Cap 0.375-16 x 1.25	Purchased	

Assembly Hierarchy (continued)

Assembly Number	Part / Assembly Name	Quantity	Material	Stock Description	Minimum Stock Thickness
3	Two Arm Assembly	2			
	Clamp Hook	1	Delrin	0.62" x 1" x 2.5"	1" THK
	Clamp Pin	1	Delrin	0.75" Diameter x 1.25"	0.75" Diameter
	Arm 1	1	Delrin	1.25" x 6" x 11.12"	1.5" THK
	Arm 2	1	Delrin	1.25" x 6" x 11.2"	1.25" THK
	Arm Ring	1	Delrin	0.362" Diameter x 0.187"	0.5" Diameter
	Brace Rod	1	Delrin	0.75" Diameter x 11.15"	0.75" Diameter
	Brace Tightener	2	Delrin	0.75" Diameter x 0.20"	0.75" Diameter
4	R.F. Coil Enclosure	2			
	Inner Cover	1	Polycarbonate	0.125" x 7.85" x 8.63"	0.125" THK
	Outer Cover	1	Polycarbonate	0.125" x 8.63" x 9.50"	0.125" THK
	End Block Cap	2	Delrin	0.375" x 0.88" x 7.88"	0.375" THK
	Side Plate Left	1	Delrin	0.375" x 3.54" x 8.4"	0.375" THK
	Side Plate Right	1	Delrin	0.375" x 3.54" x 8.4"	0.375" THK
	90 Deg Wire Elbow	1	Delrin	0.63" x 0.75" x 1.5"	1.0" THK
	Lock Set Pin	2	Delrin	0.5" to 0.25" Diameter x 4.5"	0.5 Diameter
	Pin Guide Support	2	Delrin	0.71" x 1" x 1.5"	1.0" THK
	Spring Tube	2	Rubber	0.5" OD 0.25" ID x 0.90" Tubing	0.5" Diameter
	Stand-Off Bearing	4	Delrin	0.75" to 0.375" Diameter x 0.75"	0.75" Diameter
Thumb Release Tabs	2	Delrin	1" x 1" x 1.6"	1.0" THK	
5	Screws				
	Flathead Machine Screws	< 400	Nylon 6/10	10-30	1" Long
	Metric Flathead Machine Screws	30	Nylon 6/10	M8	25mm Long

Please note that most of the assemblies are repeated more than once

Rendered Image of Completed Assembly

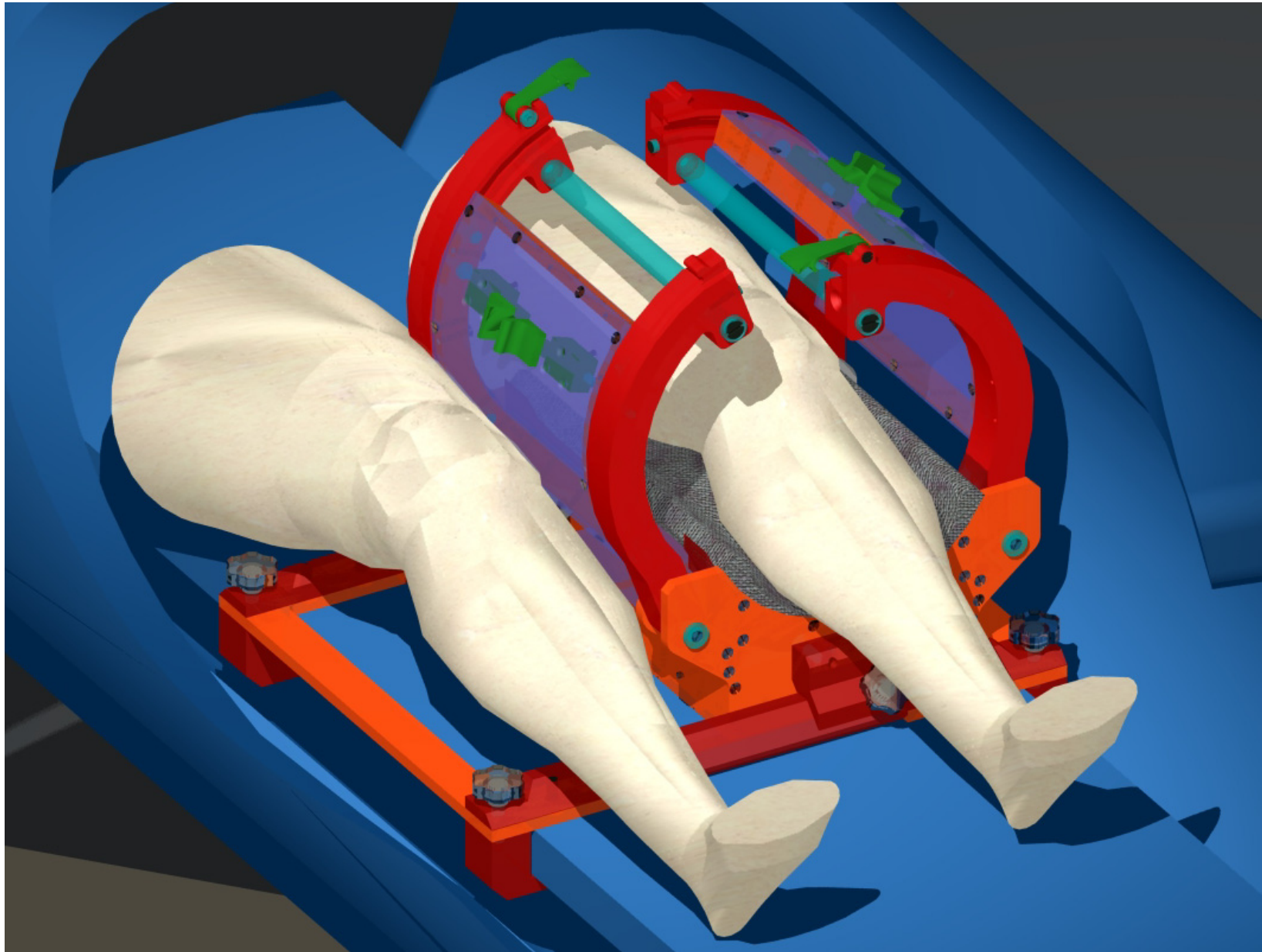

Detailed Cost Analysis Sheet:

Cost Analysis Sheet							
Raw stock							
*All measurements in inches				*All price quotes from McMaster-Carr			
<u>Material</u>	<u>Width</u>	<u>Length</u>	<u>Thickness</u>	<u>Unit Price</u>	<u>QTY</u>	<u>Price</u>	<u>Part Number</u>
Delrin	12	48	1 1/2	\$391.35	1	\$391.35	8573K96
	12	12	1/4	\$17.82	1	\$17.82	8573K15
	12	48	3/8	\$99.16	1	\$99.16	8573K89
	12	24	3/8	\$55.11	1	\$55.11	8573K37
	12	24	3/8	\$55.11	1	\$55.11	8573K37
	3/4	12	NA	\$1.97	4	\$7.88	8497K271
	3/8	12	NA	\$2.04	5	\$10.20	8572K58
Total Delrin Price						\$636.63	
Polycarbonate	12	24	1/8	\$10.61	3	\$31.83	8574K41
	1/4	8	NA	\$0.85	8	\$6.80	8571K12
Total Polycarbonate Price						\$31.83	
Nylon	1 1/2	24	1 1/2	29.02	2	\$58.04	8674K28
Total Nylon Price						\$58.04	
Fasteners							
<u>Material</u>	<u>Description</u>			<u>Unit Price</u>	<u>QTY</u>	<u>Price</u>	<u>Part Number</u>
Nylon	Flathead 10-32 machine screws 1.00" length, bag of 100			\$4.70	4	\$18.80	95133A533
	Metric Nylon Flat Head Slotted Machine Screw M8 Size, 25mm Length, 1.25mm Pitch			\$6.20	1	\$6.20	93840A531
	Nylon Female Threaded Round Standoff 1/4" Od, 7/8" Length, 10-32 Screw Size			\$1.19	2	\$2.38	96110A043
	Nylon Socket Head Cap Screw 3/8"- 16 Thread, 1-1/4" Length			\$4.92	1	\$4.92	95868A626
	Plastic Press-Fit Thumb Screw Head Rosette, Black, Fits 3/8" Screw, 1-1/2" A, 15/32" B			\$4.88	1	\$4.88	94052A146
	Nylon Socket Head Cap Screw 3/8"- 16 Thread, 1-1/4" Length			\$4.92	1	\$4.92	95868A626
Total Fastener Price						\$42.10	

Cost Analysis Sheet (continued)

Miscellaneous					
<u>Name</u>	<u>Description</u>	<u>Unit Price</u>	<u>QTY</u>	<u>Price</u>	<u>Part Number</u>
Countersink	Six-Flute Countersink 3/8" Body Dia, 1/4" Shank Dia, 1-3/4" O'all	\$8.54	2	\$17.08	3098A114
Nylon	Nylon Female Threaded Round Standoff 1/4" Od, 7/8" Length, 10-	\$1.19	2	\$2.38	96110A043
T-Slot Cutter	T-Slot Cutter 1/4" Bolt Sz, 9/16"	\$43.55	1	\$43.55	8789A16
Total Miscellaneous Price				\$63.01	
Total Materials Price		\$831.61			

