

# Structural Design for a Sustainable Transition Building

Nova Scotia, Canada

Lindsey Miller

Nathan Sarapas

Worcester Polytechnic Institute

February 21, 2013

## **Abstract**

The Major Qualifying Project proposed a sustainable structural design for an electrical transmission line's transition building. The team developed a complete structural design and analysis compensating for post-disaster scenarios and the climate of Nova Scotia. Sustainable materials were researched to be implemented into the construction of the facility for building longevity and protecting the environment. The final report for Stantec Engineering and Worcester Polytechnic Institute included design criteria to assist in the selection of the most suitable materials.

## Authorship

<b>Section</b>	<b>Author(s)</b>
<b>Abstract</b>	Lindsey Miller
<b>Capstone Design Statement</b>	Lindsey Miller and Nathan Sarapas
<b>Introduction</b>	Lindsey Miller
<b>Background</b>	Nathan Sarapas
<b>Methodology</b>	Lindsey Miller
<b>Sustainable Material Selection Process</b>	Nathan Sarapas
<b>Results</b>	Lindsey Miller and Nathan Sarapas
<b>Conclusions</b>	Lindsey Miller and Nathan Sarapas
<b>Appendix A, B, E</b>	Nathan Sarapas
<b>Appendix C, D</b>	Lindsey Miller
<b>Appendix F</b>	Lindsey Miller and Nathan Sarapas

## Capstone Design Statement

As part of the Accreditation Board for Engineering and Technology (ABET) requirement, a Capstone Design Experience must be completed by all students seeking a degree in Civil Engineering. The capstone design addresses eight, realistic constraints of a project of which include: economic, sustainability, environmental, constructability or manufacturability, ethical, health and safety, political and social aspects. The project includes all of these aspects in the final report that is submitted to both Stantec and WPI.

### *Economic*

To address economic feasibility the project determined general costs for varied design ideas. The economic analysis allows for the most effective use of money while meeting or exceeding the desired performance.

### *Sustainability and Environmental*

Sustainability was addressed through alternate structural design and proposed use of green materials. The environmental aspect was dealt with in the analysis of the property, such as a developed site containment plan. Sustainability is important to consider due to growing scarcity of resources. Consequently, changing the common practices of the industry to reduce the impacts and demands on the Earth will allow the natural resources to replenish or last until a suitable replacement can be developed. The materials and resources of the project took considerations, like LEED's outlined topic, to monitor the impact and desirable effects.

While buildings can have potential positive impacts on their surroundings, the waste generated and the wildlife displaced can have detrimental impacts on human life and wildlife. Through the site and containment plans the project should minimally impact the landscape and as it is not a full-time habitation the waste will be minimized. While the waste produced might not have an immediate impact, the loss of certain ecosystems can change a landscape.

### *Constructability and Manufacturability*

The constructability constraint for the project is reflected in the structural design of the transmission station and the multitude of design options implemented. As the project is to be constructed in a remote location, the building cannot be over-designed and must be simple in its assembly.

The materials selected for this project must all be easily obtained. Due to the remote location items will either need to be manufactured as locally as possible or preassembled and shipped to the site. Fortunately, there are contractors across Nova Scotia readily available to work on this project.

### *Health and Safety*

Health and Safety will be considered through standards of Canada, such as the National Building Code of Canada (2010). These standards were adopted to maintain and improve the health of the populace. Stantec has a thorough safety program which was used and referenced.

### *Social & Political*

The social needs of the community were addressed through the project bringing renewable power to the area. By lowering the dependency of the region on fossil fuels like coal and natural gas the future of the community is being addressed. The design confronts the social and political aspects by selecting materials and technology that allow for the area to make use of this renewable power.

## Table of Contents

Abstract.....	ii
Authorship .....	iii
Table of Figures .....	viii
Table of Tables .....	ix
1. Introduction.....	1
2. Background.....	2
2.1. Traditional and Sustainable Build Design Options.....	2
2.2. Structural Materials: Concrete .....	3
2.3. Structural Materials: Structural Steel.....	3
2.4. Component & Product Information .....	3
2.5. LEED .....	3
2.6. Cost Projections .....	4
2.7. Environmental Site Control .....	4
3. Methodology .....	5
3.1. Project Statement .....	5
3.2. Design Selection .....	6
3.3. Evaluation Criteria.....	7
3.4. Capstone Design Process .....	8
3.5. Structural Frame Model .....	11
3.6. Beam and Spandrel Beam Analysis.....	14
3.7. Joist and Decking Analysis.....	16
3.8. Column Analysis.....	19
3.9. Pedestal Analysis .....	23
3.10. Creation of Selected Design.....	24
3.11. Contrast between American and Canadian Loading Standards.....	25
4. Sustainable Material Selection Process.....	27
4.1. Typical Industry Concrete Masonry Units.....	28
4.2. Typical Industry Precast Concrete .....	30
4.3. Typical Industry Cast in Place Concrete.....	31
4.4. Typical Industry Insulated Concrete Form .....	32

4.5. Typical Industry Structural Steel .....	34
4.6. Sustainable Forms: Vulcraft (Structural Steel) .....	35
4.7. Eco Smart (Cast in Place Concrete).....	37
4.8. Sustainable Forms: Ductal .....	38
4.9. Sustainable Forms: FasWall .....	39
4.10. Final Material Selection.....	41
4.11. Waterproof Roofing .....	45
4.12. Walls & Insulation .....	46
4.13. Innovation & Add-ons .....	47
5. Final Deliverables .....	47
5.1. Proposal Paper .....	47
5.2. Presentation.....	47
6. Final Results.....	48
7. Conclusions.....	50
Appendix A: Week Detailed Task Chart .....	ii
Appendix B: Goals .....	ii
Appendix C: Hand Calculations .....	ii
Appendix D: Excel Calculations .....	ii
Appendix E: Material Selection.....	ii
Appendix F: Proposal .....	ii
Appendix G: Presentation and Poster.....	ii
Appendix H: Design Criteria .....	ii
Works Cited .....	iii

## Table of Figures

Figure 1: LEED Ratings (LEED 2009).....	4
Figure 2: 7-Week Flowchart .....	5
Figure 3: Floor Plan .....	11
Figure 4: Joint Loading.....	11
Figure 5: Roof Loading.....	12
Figure 6: Percent Utilized .....	12
Figure 7: Deflection Diagram .....	13
Figure 8: Moment .....	13
Figure 9: 3D SAFI Model .....	14
Figure 10: Beam Layout .....	15
Figure 11: Joist & Decking Location .....	16
Figure 12: Joist Depth Selection .....	17
Figure 13: Joist and Decking Layout .....	19
Figure 14: Pedestal & Footing .....	22
Figure 15: Footing Locations.....	23
Figure 16: CMU Types (Heiserman) .....	28
Figure 17: Precast Structures (Total Precast Concrete Structures) .....	30
Figure 18: Cast in Place Concrete (Cavity Wall: Brick Veneer/Reinforced Concrete Wall) .....	31
Figure 19: ICF Interlocking Form (Walls).....	32
Figure 20: ICF Composition (Alter) .....	33
Figure 21: Structural Steel (Services) .....	34
Figure 22: Strong Steel (Engineers).....	35
Figure 23: Vulcraft Products (Products) .....	36
Figure 24: Versatile & Varied in Use (Environmentally Friendly Construction).....	37
Figure 25: EcoSmart Concrete (Concrete*enthusiast).....	38
Figure 26: Durable Ductal Concrete (Ductal Advantages) .....	38
Figure 27: Ductal Life Projections (Sustainable Development) .....	39
Figure 28: FasWall & Shelterworks Logos (FasWall Home).....	39
Figure 29: FasWall Block (FasWall Home) .....	40
Figure 30: FasWall Project in Progress (FasWall Home).....	44
Figure 31: Vulcraft Track Record (Owners).....	45
Figure 32: (Snow: Story of the Snowflake) .....	46
Figure 33: Deliverables.....	48
Figure 34: 3D SAFI Model.....	49



## Table of Tables

Table 1: 7 Week Detailed Task Chart.....	6
Table 2: Task List .....	7
Table 3: Calculated Loading.....	9
Table 4: Specifications.....	10
Table 5: Beam Dimensions.....	16
Table 6: Joist Depth.....	18
Table 7: Decking Results.....	18
Table 8: Tributary Area .....	20
Table 9: Column Design.....	21
Table 10: Footing Selection.....	21
Table 11: Footing Results.....	22
Table 12: Pedestal Dimensions.....	24
Table 13: Pedestal Reinforcing Steel.....	24
Table 14: Load Variables.....	25
Table 15: Load Development.....	26
Table 16: Material Analysis Spreadsheet Results.....	41
Table 17: Environmental Comparison.....	42

## 1. Introduction

The coastal electric project spanning from Newfoundland to Nova Scotia is designed to connect communities to the supply of sustainable electrical power. The three main components of the project are to implement a new transmission line in Newfoundland, a second transmission line in Nova Scotia and add two subsea cables spanning the stretch between the two. In the Major Qualifying Project, students designed one of the two converter stations that house the diffusion of the transmission line's alternating currents. The team documented multiple project design options and costs for the structure. The project discusses fiscal responsibilities and sustainable options as to discern the most effective option that uses both traditional and green building options.

The project uses a multitude of materials to research the many options for design and cost of the building. Including, Canadian and local Nova Scotia codes that were used to meet all structural requirements. One national code the group used, yet will not be limited to, is the National Building Code of Canada (2010) specifically for the structural design work. For the sustainable and green options Canadian LEED requirements were analyzed and implemented.

In addition to the Design Team's efforts a second project team from WPI proposed a document on the construction management for the same structure. Quality assurance for both projects was provided through weekly meetings with the Worcester Polytechnic Advisors and daily meetings with both the Management Major Qualifying Project Team and the Stantec Consulting Ltd. (Stantec) Project Mentor Team.

The project aimed to complete a full design of the structure from foundation to roof and to discuss the many benefits of building green. The Design MQP Team aimed to provide multiple options for these designs to incorporate sustainable building, such as use of innovative materials, new economic systems encompassing the mechanical and electrical systems. Going beyond the required sustainable building requirements, the team proposed the most fiscally and environmentally responsible final product.

As the Design Team developed the structure the cost of materials for the designs were analyzed. The pricing looked at components including, sustainability, functionality, cost efficiency, return on investment and any added value for innovative practices. Once the financial aspects were

compiled, the designs and cost estimates were compared and reviewed to find the most viable project.

With the collaboration between student groups, the Management Team and Design Team, Stantec's mentorship and the advisors from Worcester Polytechnic Institute, the Major Qualifying Project prepared this report discussing the options for a transition building along a transmission line's path including the design and cost estimate.

## **2. Background**

### **2.1. Traditional and Sustainable Build Design Options**

Building sustainably pertains to both the decisions made in the design phase and the construction phase. In design, there are many different components to consider including longevity, additions, and efficiency. The least expensive material may not be the best material for the job if it does not last as long. Wood beams would not be a good choice for a large multiple story building, as the strain would eventually cause the wood to break. Additions to a project are things added to reduce energy demand or impacts on the environment. Examples include an enhanced ventilation system, extra insulation, and motion sensors. These pose an additional cost to the project, but may have a return on investment or conserve an invaluable natural resource. Efficiency is closely related to the materials chosen. Glass windows, for example, relate to the efficiency through their quality. If the window leaks air, it means more heating is required in the colder months. If it is thin, the window can break more easily and also loses heat more easily. There are windows designed to retain heat through the use of thicker panes and pockets of air. The type of window is just one choice in the world of building efficiently and sustainably. Sustainability in construction has a lasting impact by reducing demands on natural resources and using local ones.

The traditional build option is a Design/Bid/Build process, where there are three parties involved. The owner of the project hires a designer, and all the design work is done prior to the bidding or involvement of contractors. When the design is complete, contractors are invited to bid on the expected cost for to complete the project. Based on the owner's criteria, a general contractor is chosen to complete the job. This process can be time consuming if the design is complex. If a design is complex, it is more likely changes will be made to the design during the

construction phase. However, design is typically 10 to 15 percent of the total project cost, and having it completed before construction begins can avoid costs incurred during construction due to changes in scope (Salazar). This project delivery also may also allow the owner to be more involved in decisions related to the sustainability of the design.

## **2.2. Structural Materials: Concrete**

Concrete is commonly employed in construction due to its ability to fit a number of different shapes and durability. Concrete is also typically reinforced with steel frames within the cast. Concrete has many different types, three of which include slab, reinforced, and pre-stressed. Slab concrete is a thicker concrete, and used for foundations. It is reinforced with steel or metal framework along with precast concrete. The extra thickness allows for it to support the weight of the building. Reinforced concrete is designed to deal with higher levels of tensile stress. Accordingly it has steel bars placed inside it to allow it additional flexibility (Encyclopedia Britannica). Without the bars, the concrete might crack extensively. Pre-stressed concrete is similar to reinforced concrete, but uses wires instead of bars to deal with active loads (Portland Cement Association).

## **2.3. Structural Materials: Structural Steel**

Prepared for specific purposes steel can be manipulated for many different roles. Structural steel is rated and prepared for creating a framework for the building. Solid bars can be used for reinforcement and in certain shapes make a building's foundation or slab more effective. The framework of a building is composed of columns, girders, beams and joists, essentially composing the skeleton.

## **2.4. Component & Product Information**

The project contains and details materials chosen or recommended for the completion of the transmission building. These details discuss why each item was chosen and the purpose it fulfills. Different parts of the building face different demands, and thus some components faced more scrutiny.

## **2.5. LEED**

Leadership in Energy and Environmental Design is relatively new, but becoming more common in the building world after its creation in 1998. LEED certification is based on numerous categories and the categories vary from whether the building is for commercial, residential,

health care, military, or other purposes. These categories include efficiency in water, heat, and light use (LEED 2009). Anything that saves resources saves money also. Buildings need to be healthy places to live, whether this means protecting of the water sources in a home or mold prevention in a school. There are numerous other categories, and points are earned in each category. Based on the total number of points, a LEED rating is given. The possible rankings are below.

Certified	40-49 Points
Silver	50-59 Points
Gold	60-79 Points
Platinum	80+ Points

Figure 1: LEED Ratings (LEED 2009)

### **2.6. Cost Projections**

Cost projection entails how much using a material will cost over time, allowing for the owner to consider return on investment. This does not include the cost of the labor to install it. It is worth noting that the materials discussed are, for the most part, readily available. As such, the cost of transportation is not a large factor for most materials. Expected maintenance and upkeep are the focal points in this section.

### **2.7. Environmental Site Control**

The specifications given by Stantec clearly lay out how the site will be prepared. The entire site will be cleared and grubbed of vegetation (Page 11 of Stantec Specs). This is to ensure no plants can grow or erode the building. The remaining soil will be compacted and covered with gravel, preventing plants from growing in the future (Page 12 Stantec Specs). Erosion will be dealt with by standards in the Erosion and Sedimentation Control Handbook for Construction Sites. These include setting up barriers around the edge of the site to catch runoff and filter water (Page 12). Barriers can include the standard black fabric fences or hay. The fences will be removed after the project is complete.

### 3. Methodology

#### 3.1. Project Statement

The aim of the Design Project Team was to formulate a full report using multiple design options to provide a structural design for the most sustainable, cost efficient transition building for the coastal electrical project. Having identified key tasks highlighted in Table 1 the design was scheduled around these and followed Stantec’s procedure for design approvals for design evaluation. This chart was used to facilitate project process. Additionally the team has provided an itemized weekly goals list seen in the appendix Chronological Goal List. Verbalized goals helped the group setup and track the project more effectively. The pace of the project was tracked in the weekly activities plot summarized in flowchart (Figure 2) and seen in the following Table 1.

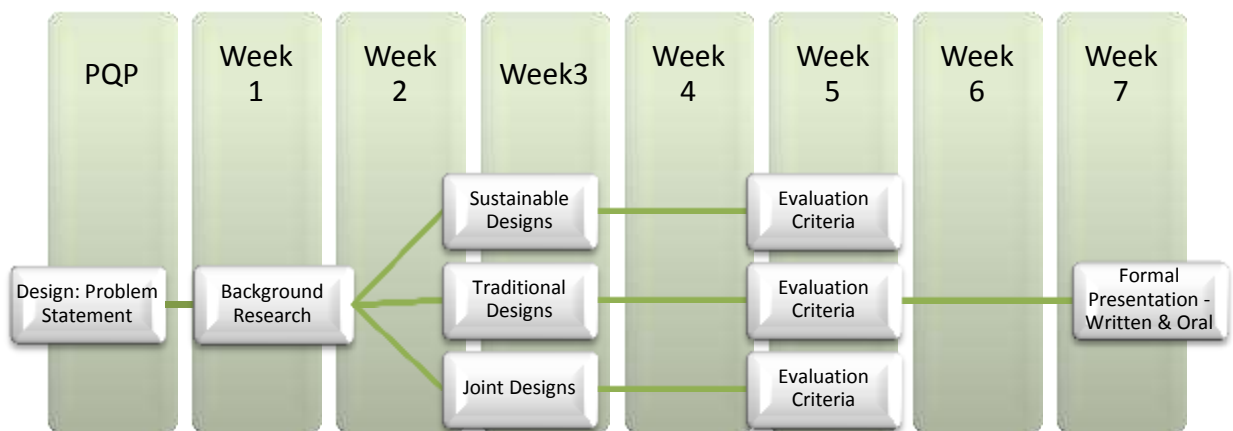

Figure 2: 7-Week Flowchart

Activity	Week 1	Week 2	Week 3	Week 4	Week 5	Week 6	Week 7
	1/9 - 1/18	1/21 - 1/25	1/28 - 2/1	2/4 - 2/8	2/11 - 2/15	2/18 - 2/22	2/25 - 3/1
<b>Acclimation Period</b>							
Move in to Housing							
Orientation of Stantec office and Dartmouth Area							
<b>Background Research</b>							
Identify possible resources							
Identify key Stantec employees							
Review project documents							
Review older related Stantec projects							
Identify site factors related to construction methods							
<b>Design Work</b>							
Sustainable Design							
Traditional Design							
Joint Design							
Sustainability							
Functionality							
Building codes							
Investment							
Added Value							
<b>Analysis &amp; Finalization of Designs</b>							
Analyze benefits & detriments of each material							
Assess the ability to use materials on specified project							
Finalize materials & design							
<b>Final Report</b>							
Start final deliverables							
Critique results							
Finish final deliverables							
Present to Stantec							

Table 1: 7 Week Detailed Task Chart

### 3.2. Design Selection

Design of the transmission building included code familiarization, interviews with the Stantec staff, on-site research when permitted, and use of design software. The interviews with the Stantec team allowed for the WPI project team to get a basic understanding about starting points. The design had to comply with all national codes, thus the design had to be cross-checked by all listed specifications and codes in standards like the National Canadian Building Code and the CPCA Concrete Design Handbook. The completion of these designs was aided through the use of computer software. Provided by the company, both MQP teams were given privileges to use SAFI, which is a structural analysis software used widely in engineering for designing everything from bridges to schools.

Selection of the most qualified design for the project was done through taking into consideration traditional design work, sustainable materials and methods and finally how to combine those two. The following section details how each were considered and then evaluated. Table 2: Task List shows the way the team was able to track and evaluate the following criterion. The x indicates the completion of the step.

Steps for Design (Si Units)	Initial Design	Leed/Sustainable Option	Calculations	Check	Revise & Check	Hours Re'qd	Cost (Hours)	Cost (Drawings)
Basic Building Layout & Hand Sketches	x	n/a	x	x	x	16	\$2,000	\$15,000
Reinforced Concrete (Foundation)	x	x	x	x	x	24	\$600	\$5,000
Steel (Frame Design)	x	x	x	x	x	24	\$200	\$5,000
Steel (Beam Design)	x	x	x	x	x	16	\$200	\$5,000
Steel (Girder Design)	x	x	x	x	x	16	\$200	\$5,000
Steel (Column Designs)	x	x	x	x	x	16	\$200	\$5,000
Roof System	x	x	x	x	x	24	\$200	\$10,000

**Table 2: Task List**

### *Traditional Design*

This design is the original design where the team designed the structure in the most efficient way and applied the most commonly used methods. The team chose the most cost-effective material for the climate and codes.

### *Sustainable Design*

During the process of the original design, the team identified components that could be made sustainable. The team then analyzed each of these possibilities based on criteria including local impacts and resources, return on investment, and complying with future regulations. This design has as many sustainable ideas as were conceived in the design process. The team also identified the cost and materials used in this design.

### *Combined Designs*

The team took the sustainable and traditional designs and used components from each to create a hybrid design. This allows for a less expensive building, while still considering impacts on the environment. There are many more options with this method, thus there were several variations for the combined structure's design.

### **3.3. Evaluation Criteria**

The evaluation criteria was selected based on the qualities that LEED certification is based on, as well as, the aspects of the Capstone Design Statement.



### *Sustainability*

The team reviewed all the designs and made decisions about using components based on their social and environmental impact. These decisions were based on available codes, environmental impact studies, availability of resources, and future demands.

### *Functionality & Compatibility*

The team reviewed the building to ensure its durability in the environment. The team ran simulations when possible and researched how similarly constructed building or components fared in adverse conditions. Based on the research, the team made estimates as to the life expectation and maintenance of the building. All designs were revised when there was a conflict with building specifications & codes.

### *Innovation*

The team considered any additional value to add aesthetics or other components to the building. The criteria included aesthetic value, and future needs.

## **3.4. Capstone Design Process**

### *Apply Evaluation Criteria*

The upcoming sections, 3.4 through 3.10, show the process of how the structure was designed piece by piece. The design criterion and assumptions are first called out so that one can understand what was used to find the initial design. The structural frame design section helps give a better representation of the project from a 3D standpoint and displays the structure and each component. Each section after the structural frame design is compiled of a methodology, results and conclusions subsection. The purpose of this is to help respectively detail the exact procedure, findings and deductions of the calculations.

### *Design Criteria & Assumptions*

To design the transition building, an analysis of the multiple components that make up the structure was performed. The purpose behind the analysis was to develop the best understanding for the steel members and concrete foundation. LRFD load combinations were used to find the post-disaster critical design loading.

Using the National Building Code of Canada 2010 the structure was designed to meet the climate of Sydney, Nova Scotia and withstand Post Disaster conditions. Knowing that the building needs to account for electrical transmission equipment the building was given a square-meter area of 260 m<sup>2</sup> and a height of 8 meters. The loadings for the dead, live, snow, wind and seismic loads were developed to find the most critical loading. The calculated loading can be found in the following Table 3: Calculated Loading. The live and dead loads were provided in the Stantec Engineering's preliminary design criteria. The most critical loading was developed in an Excel sheet seen in the appendix fully.

<b>Load Development</b>		
<b>Floor Loads</b>		
Dead Load=		3 kpa
Live Load		
At grade		25 kpa
<b>Roof Loads</b>		
Dead Load=		4.3 kpa
Live Load=		1 kpa
Basic Snow Load=		3.15 kPa
Snow Drift Load=		0.75 kpa
Snow Total=		3.9 kpa
<b>Wind Loads</b>		
Winward=		1.516416 kPa
Leeward=		-1.37535 kPa
Uplift=		-2.0454 kPa
<b>Seismic Load</b>		
5%		% of dead Weight
<b>Load Combinations</b>		
<b>FLC</b>		
Max =		10.23 kPa
Min =		0.43 kPa
<b>ULC</b>		
Max =		9.20 kPa
Min =		2.05 kPa

Table 3: Calculated Loading

Assumptions made for the structural analysis also include the provided steel and concrete strengths along with required soil bearing strength seen below Table 4: Specifications.

Specification Used for Calculations (kPa)		
Fy	4.00E+02	MPa
f'c	30	MPa
q <sub>allowable</sub>	150	kPa

**Table 4: Specifications**

Given all of the factors the design analysis consistently used these in the evaluation of the beams, columns, connections, baseplates, footings and concrete pedestals.

### 3.5. Structural Frame Model

#### *SAFI*

SAFI 3D model was created in order to confirm that the calculated members and joints were all acceptable in moment design, deflection and were utilized to an optimum. Figure 3: Floor Plan shows the top view of the members and include the beams, spandrel beams and joist layout. The model was used throughout the design process and helped to facilitate the visual aid.

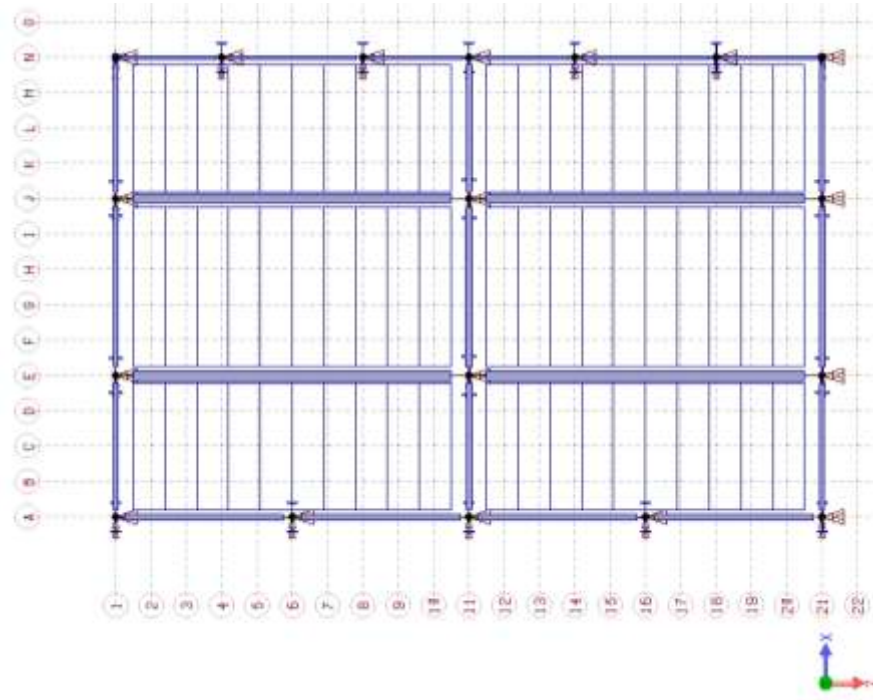

Figure 3: Floor Plan

In order to confirm that the members were sufficient in design the loading was programmed into the software. Figure 4: Joint Loading and in Figure 5: Roof Loading show loading at a column and the overall roof loading. Other loads included were wind, seismic, snow, dead and live.

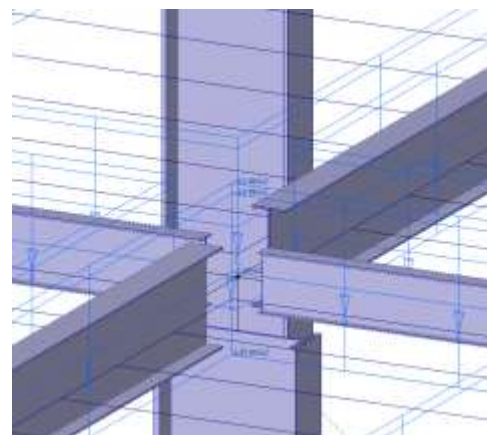

Figure 4: Joint Loading

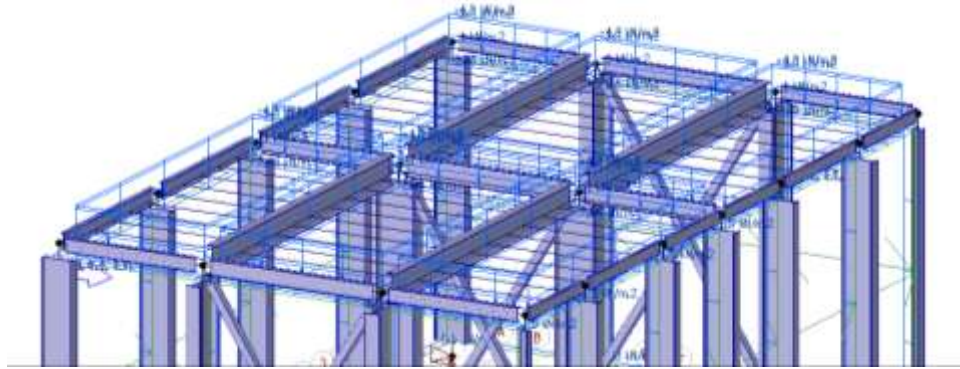

Figure 5: Roof Loading

Next the structural model helped to confirm the size of the members through deflection and percent utilized. The optimization of each member can be seen in the highlighted members' specific colors. The key is to the right of Figure 6: Percent Utilized. Here it was found that the designed moment connections were not sufficient and cross-bracing would be required.

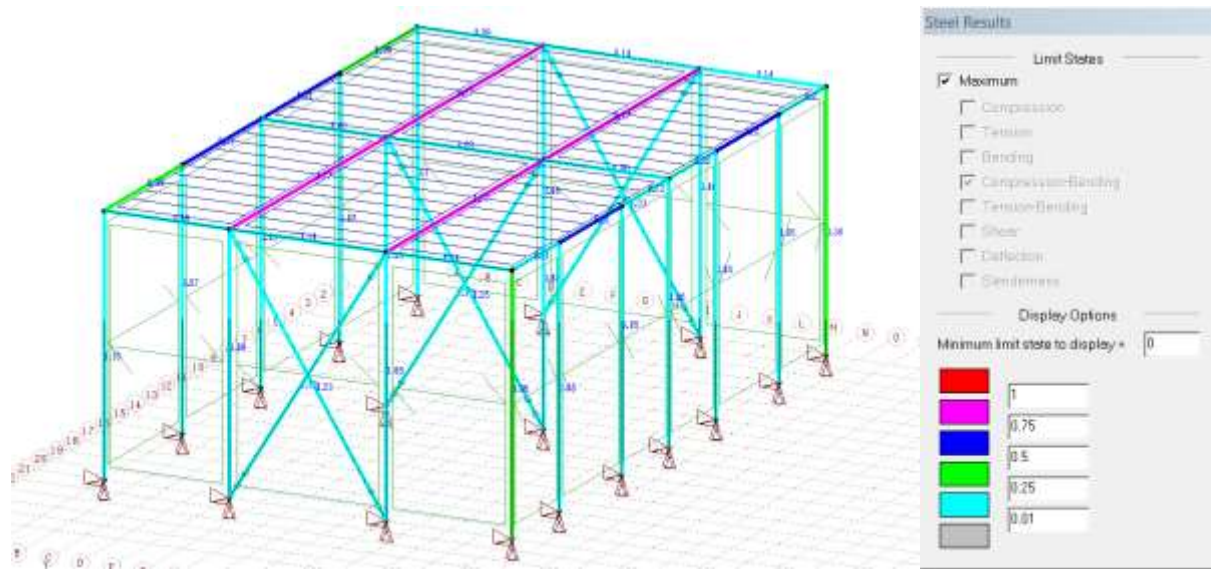

Figure 6: Percent Utilized

The deflection and moment of each member were calculated in the report and shown in Figure 7: Deflection Diagram. The moment can be found in Figure 8: Moment. Finally, using the view settings the structure was able to be seen as a full 3D model with steel weight as displayed in Figure 9: 3D SAFI Model.

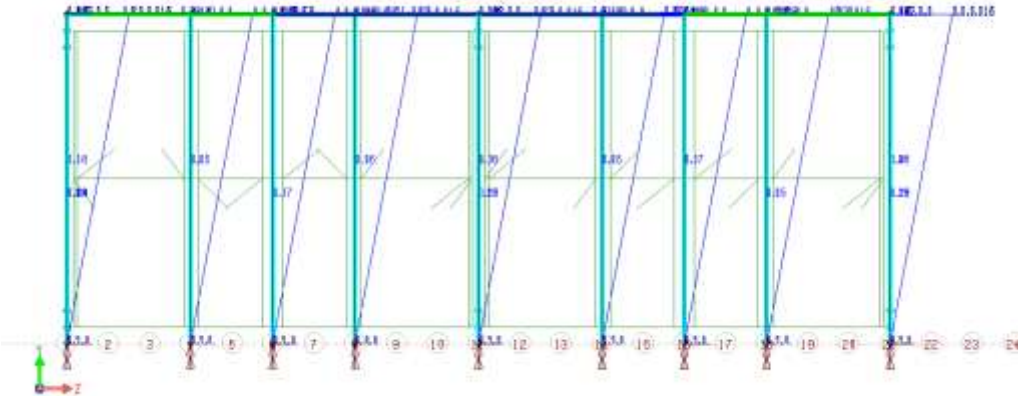

Figure 7: Deflection Diagram

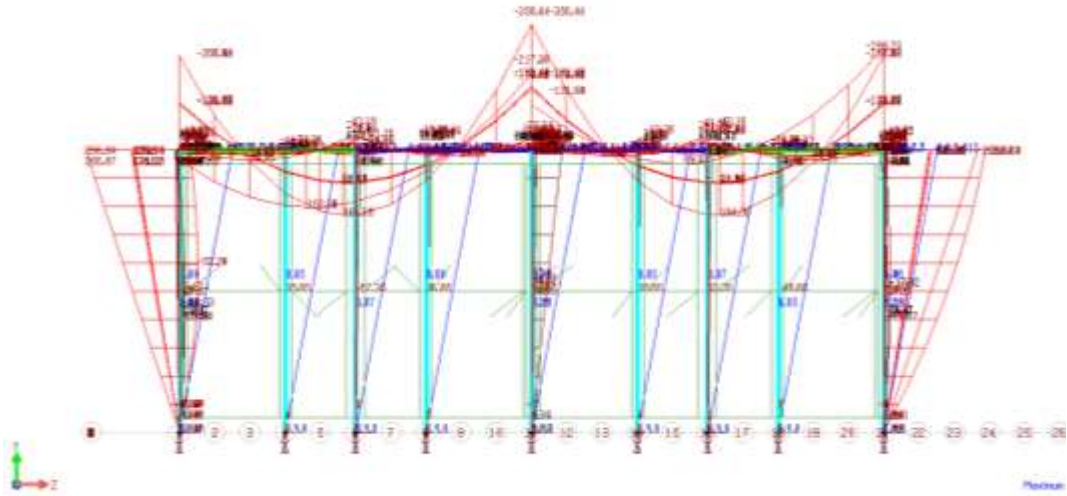

Figure 8: Moment

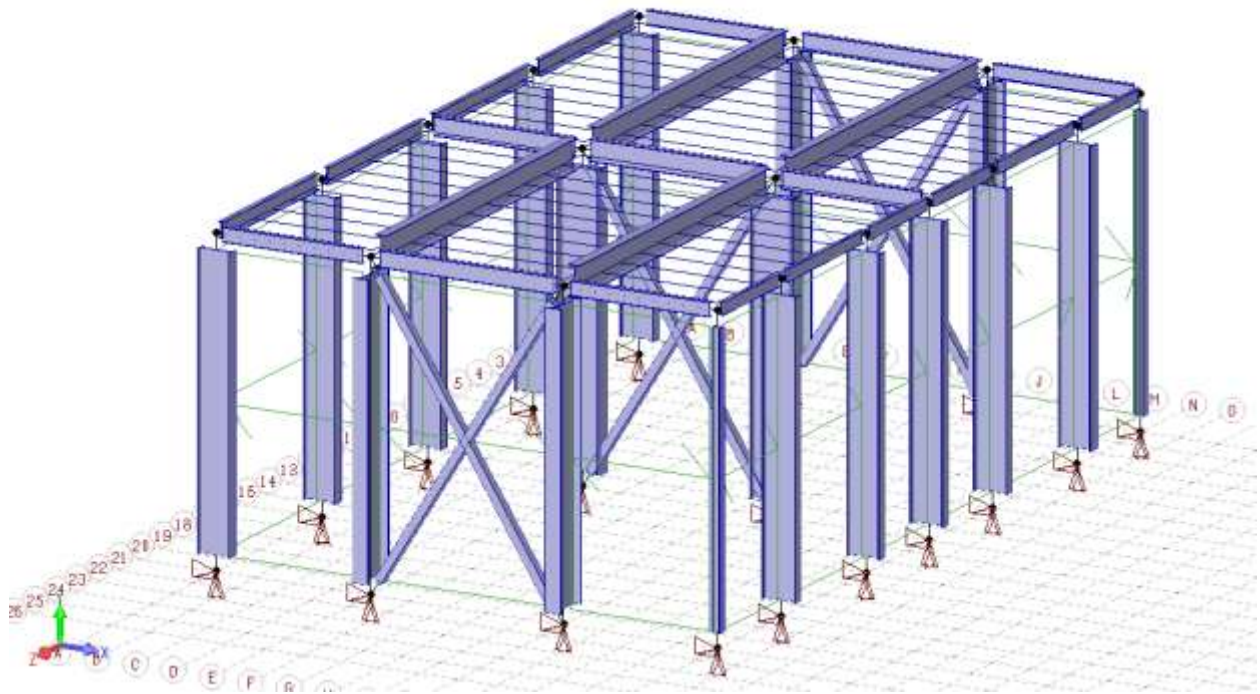

Figure 9: 3D SAFI Model

### 3.6. Beam and Spandrel Beam Analysis

#### *Methodology*

Spacing for both the beams and the spandrel beams, were included in the preliminary design criteria provided by Stantec, along with lengths. Using Excel spreadsheets and structural calculations the beams were selected. The hand calculations and Excel spreadsheets can be located in the appendix. In Figure 10: Beam Layout beams are highlighted in green, spandrel beams are pink, and columns are primrose.

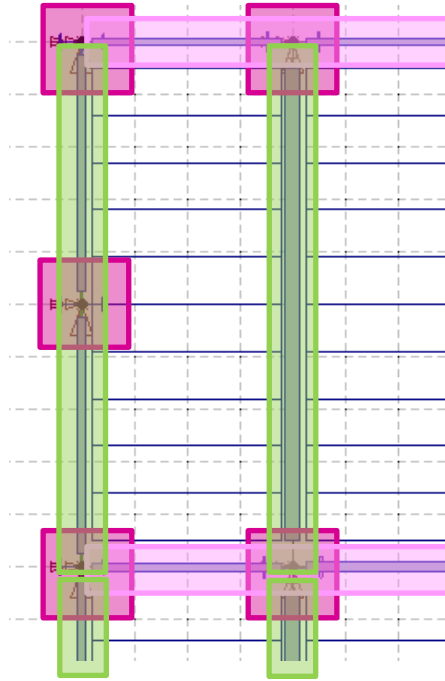

Figure 10: Beam Layout

### Results

The analysis for the spandrel beam and for the beam was treated in an analogous manner. Calculations from the load development Excel spreadsheet provided the loadings for the spandrel beam. Given this and the tributary width the governing design moment, shear force and required moment of inertia were found. Using these, a beam shape was selected. To select a W-shape beam a table for W-shape beams in the CISC Handbook of Steel Construction was used to find a beam that more than satisfied the calculated values. The adequacy of the spandrel beam was confirmed through calculation the deflection and ensuring that it did not surpass the standards requirements. Deflection due to loading was calculated using the equations for  $\Delta$ :  $w_u$  being the unfactored loading and E being the strength of steel at 200,000 MPa.

$$\Delta = \left( \frac{5(w_u)L^4}{384EI} \right)$$

The deflection for service load and dead load were compared with the appropriate span length over the unsupported deflection limits to find if the beams were sufficient.



### Conclusions

Evaluation of the selected beams can be found in the following tables. Table 5: Beam Dimensions shows the basic measurements of the beams' lengths and tributary width and the size selected to be analyzed. The most economical section was chosen from the table in the CISC manual and used in the further analysis of the structure.

Beam			Spandrel Beam		
Length	Size	Trib. Width	Length	Size	Trib. Width
10.0	W760x134	10.0	4.0	W360x33	5.0
5.0	W410x39	2.0	5.0	W410x46	5.0
4.0	W310x28	2.0	4.0	W460x52	10.0
3.0	W310x28	2.0	5.0	W530x66	10.0

Table 5: Beam Dimensions

### 3.7. Joist and Decking Analysis

Location and direction of the joist and metal decking in comparison to the beams and spandrel beams can be seen in Figure 11: Joist & Decking Location. The joists are stretching from left to right (seen in yellow) where the decking's grooves will run from top to bottom as they overlap the beams and joists.

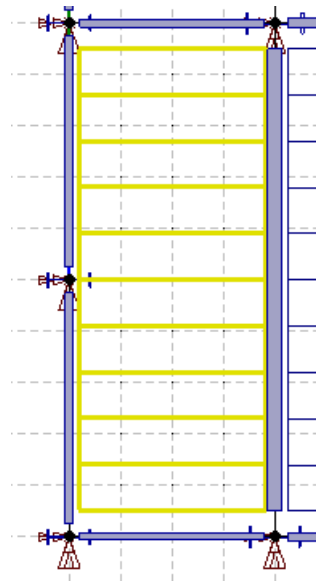

Figure 11: Joist & Decking Location

### Methodology

For calculation of the joists the steel is designed for live load deflection similar to the beams. To begin, the spacing of the joists is estimated. For all joists this measurement is between 1 and 1.5 m. For this structure each joist is spaced at 1.2 meters apart and varies in length between two types. Using this, the tributary width can be calculated. The moment is found and used to find the value of  $I_x$  with the depth of the joist. The joist depth must be selected from a table found in the Canam Catalogue for Joist Girders ("Our Products and Services / Canam."). See following Figure 12: Joist Depth Selection for selection. Live load deflection is then left to be found and using all the previously calculated variables can be found and compared to the allowable deflection. If acceptable the calculated deflection will be equal to or less than the live load deflection.

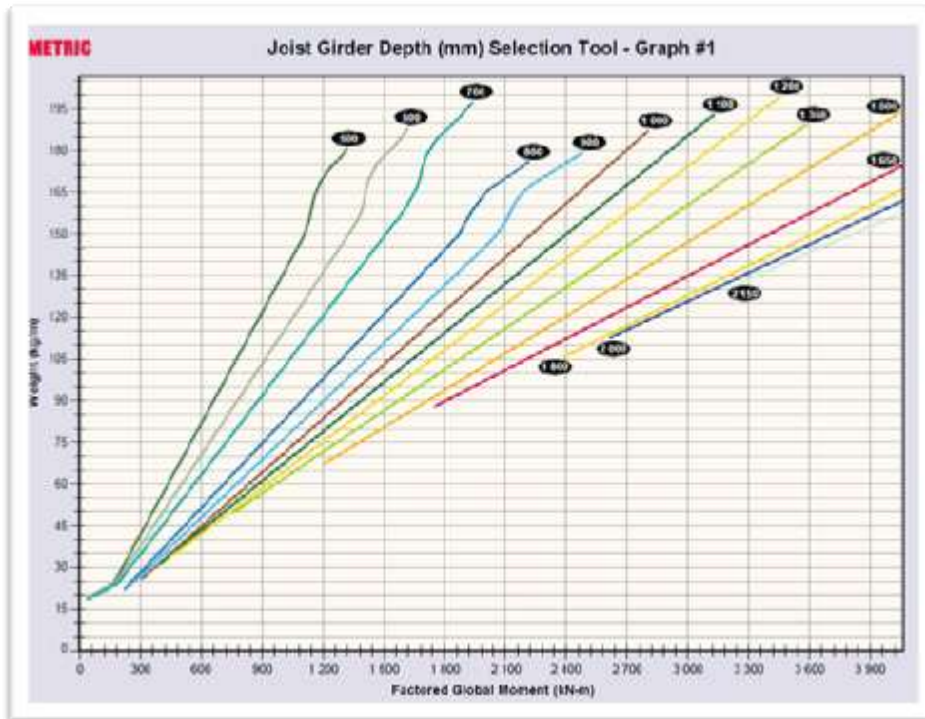

Figure 12: Joist Depth Selection

Designing the steel decking the Canam Catalogue was used again, but this time to find the appropriate composite. Composite is the depth of the concrete atop the decking and the system which attaches the two. Typically used in industrial buildings is the 3606 series. Selected for the design was type 3606-20 with 100 mm thick concrete slab. Next the width of the section was

selected. Having two separate bays of 4 and 5 m two widths were selected. The panels require 300 mm overlap and to span over 3 supports. Using the knowledge that the joists were to be spaced at 1.2 meters, a deck that spans over 1200 mm allows for sufficient overlap and support. The table from page 10 of the Canam Steel Deck Manual provides the factored resistance loading. The factored resistance loading compared to the known roof loading shows if the deck will be able to withstand the loading. Next, the live load was used to find the deflection in both panels, which needed to be smaller than the allowable amount. A final check to see if the total surface area was greater than the square area of the facility was used to confirm that there would be enough overlap.

**Results**

Through the use of the Canam manual, the Joist Depth Selection table allowed for the analysis of depths per the moment of the joist girder. Three depths were selected to be analyzed, seen in Table 6: Joist Depth

, the results show the comparison of the different depths with their calculated deflection.

Joist Depth Selection Results			
Depth	I <sub>x</sub>	Δ <sub>(LL)</sub>	Δ <sub>(allowable)</sub>
mm	(*10 <sup>6</sup> ) mm <sup>4</sup>	mm	mm
Alternate 1			
500	19.59	5.000	16.670
600	21.51	4.17	16.670
700	27.43	3.57	16.670
Alternate 2			
500	30.61	7.816	20.830
600	36.73	6.514	20.830
700	42.86	5.582	20.830

**Table 6: Joist Depth**

The selected decking was type 3606-20 in 1200 mm spans. Found was the loading of the resistance factors and the deflection of the selected panels. The results can be found in the following Table 7.

Steel Decking Selection	
1200 mm Span	
W <sub>r</sub> (kPa)	W <sub>f</sub> (kPa)
20	10.23
Δ <sub>(LL)</sub> (mm)	Δ <sub>(allow)</sub> (mm)
0.114	3.33

**Table 7: Decking Results**

### Conclusions

Working in conjunction the joist girders and the metal decking are sufficient to support the loading applied. Figure 13: Joist and Decking Layout below depicts the location for the selected paneling and placement for each section.

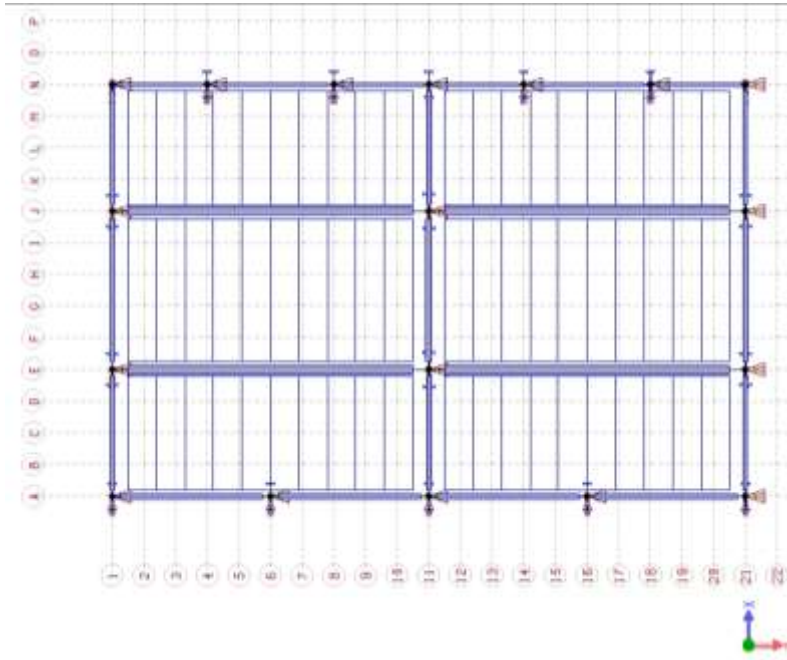

Figure 13: Joist and Decking Layout

### 3.8. Column Analysis

#### Methodology

To design for an axially loaded column the factored loading was found and then used to find the new moment. Assuming the column was pinned at both ends the effective length factor (K) was determined to be 1.0. The minimum radius of gyration,  $r_x$  and  $r_y$ , were found and later used to confirm selected structural steel shape, in most cases this is a W-shape. The moment of inertia was found using the following equation

$$I_x = \frac{PL^3}{3E\Delta_{max}} + \frac{P\left(\frac{L}{2}\right)^2\left(3L - \left(\frac{L}{2}\right)\right)}{6E\Delta_{max}}$$

Using  $I_x$ ,  $M_u$ ,  $r_x$  and  $r_y$  the W-shape was selected using Chapter 4 of the Handbook of Steel Construction. Using the length, K and governing  $r$ ,  $C_r$  can be found through the following

equation or Table 4-4. The percent utilized is then used to check the selected column.  $C_r$  is the factored compressive resistance of the member and  $\lambda$  is a dimensionless design parameter seen below.

$$C_r = \Phi A F_y (1 + \lambda^{2n})^{-\frac{1}{n}}$$

### Results

The columns were selected per the previous procedure and using the CISC Handbook (Handbook of Steel Construction) shows each column and its loadings. Table 8: Tributary Area shows the tributary areas analyzed for the entire structure and their calculated loadings; following that, Table 9: Column Design highlights the location of each column and the sizes selected. The columns selected to be analyzed were selected by having the largest factored loading, largest factored moment, the second largest factored loading and then the smallest factored loading and moment. Table 8: Tributary Area shows the areas with all their traits; the darker areas are the designed columns. The areas were narrowed down to 1, 2, 4 and 5. Having then designed the columns to meet these requirements it was seen that areas 3, 6 and 7 had measurements between areas 4 and 5, therefore column size 4 was used for those areas as well. Table 9: Column Design charts out the location of each column the w-shape selected and the tributary area category.

Area	Width m	Wind Bearing Side	Length m	Height m	TA m <sup>2</sup>	Panel m <sup>2</sup>	P kN	Pf kN	M kN*m
1	4.5	<	10	8	45	36	414	460.125	34.70125
2	4.5	<	5	8	22.5	36	207	230.0625	34.70125
3	2	>	2.5	8	5	20	46	51.125	30.328329
4	2	>	5	8	10	40	92	102.25	60.656657
5	2	<	1.5	8	3	16	27.6	30.675	24.262663
6	2	>	3.5	8	7	28	64.4	71.575	42.45966
7	2	>	3	8	6	24	55.2	61.35	36.393994

Table 8: Tributary Area

Column					
Location	Size	Type	Location	Size	Type
1A	W8400x193	4	3C	W1100x499	1
1B	W1000x321	2	3D	W8400x193	4
1C	W1000x321	2	3.5D	W8400x193	4
1D	W610x113	5	4A	W8400x193	4
1.5D	W8400x193	4	4.5D	W8400x193	4
2A	W8400x193	4	5A	W8400x193	4
2.5D	W8400x193	4	5B	W1000x321	2
3A	W8400x193	4	5C	W1000x321	2
3B	W1100x499	1	5D	W610x113	5

Table 9: Column Design

### Conclusions

All columns that are in line with the windward side of the interior columns will be larger than sizes used for the leeward side. This can be seen in the tributary areas 1 and 2. The columns are much larger than areas 4 and 5. All columns excluding 5D and 1D will be W-shape W8400x193 to meet the required loadings and moments. Footing Analysis

As footings are crucial for the support of the structure the footings to be designed were based on 4 out of the 7 possible footings. Selecting the block with the largest and second largest factored loading, the largest moment and then the smallest factored loading and moment the design and was calculated as follows. The Table 10: Footing Selection highlights the selected footings as 1, 2, 4, and 7.

Area	Width m	Wind Bearing Side	Length m	Height m	TA m <sup>2</sup>	Panel m <sup>2</sup>	P kN	Pf kN	M kN*m
1	4.5	<	10	8	45	36	414	460.125	34.70125
2	4.5	<	5	8	22.5	36	207	230.0625	34.70125
3	2	>	2.5	8	5	20	46	51.125	30.328329
4	2	>	5	8	10	40	92	102.25	60.656657
5	2	<	1.5	8	3	16	27.6	30.675	24.262663
6	2	>	3.5	8	7	28	64.4	71.575	42.45966
7	2	>	3	8	6	24	55.2	61.35	36.393994

Table 10: Footing Selection

The ideal depiction of the footing to pedestal connection can be seen in the Figure 14: Pedestal & Footing below to give a visual representation of what was calculated.

### Methodology

The concrete strength was provided as 30 MPa and soil bearing strength of 150 kPa and the design assumes the pedestal area of 0.25 m. With the equation below, one can solve for the concrete area and then the length (b) of the sides of the footing. Assuming this to be a square footing the length can be found by finding the square root of the area.

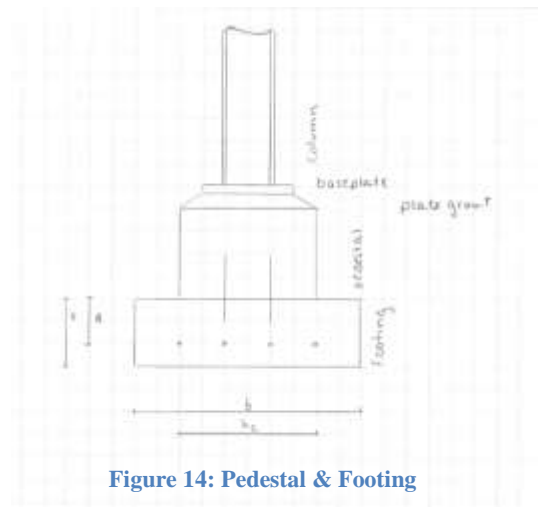

Figure 14: Pedestal & Footing

$$P_f > F_{br} = 0.85A_c \Phi_c f'_c$$

To account for the added weight of the structure the design was calculated for 85% of the loading. Next to check the appropriateness of the footing and find the depth (d) at which the rebar will be buried the shear capacity was found in one-way and two-way; lending itself to solve for the thickness (t) of the block as well. The area of steel ( $A_s$ ) was next calculated using the table 2.1 from the Concrete Design Handbook. (Concrete Design Handbook.). Finding the  $A_s$  minimum then gave the number of bars to be used and the spacing of those bars.

### Results

The selected footings with their parameters are detailed in Table 11: Footing Results.

	$A_c$ m <sup>2</sup>	b mm	d mm	t mm	$A_s$ (min) mm <sup>2</sup>	bar type	# of bars	spacing mm
1	2.89	1700	150	300	1530	20M	8.0	200
2	1.44	1200	75	200	1611	20M	6	190
4	1	1	75	200	503	20M	6	150
7	1	1	75	200	400	20M	6	150

Table 11: Footing Results

### Conclusions

Overall the concrete footings to be used will be of two different sizing to account for the seven total different tributary areas. Footings 1 and 2 will be used. In the following Figure 15: Footing Locations the place of each are called out.

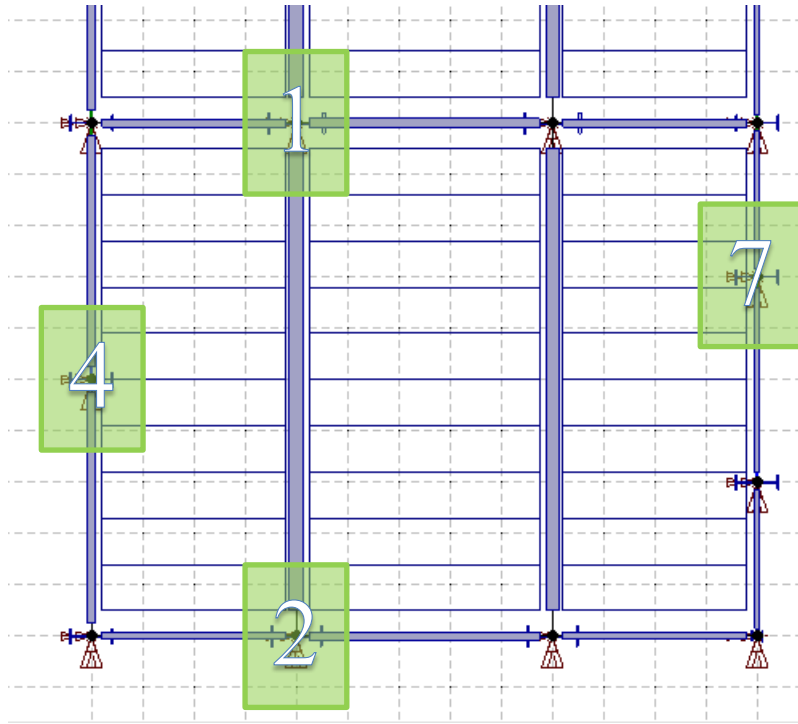

Figure 15: Footing Locations

### 3.9. Pedestal Analysis

#### *Methodology*

Based off the required depth for the footing the height of the pedestal became an assumed 1 m tall. Using similar techniques to the footing calculations the pedestal was treated as a short concrete column. The gross area was calculated using the assumption the column was  $.25 \text{ m}^2$  at its base. Using the calculated moment, length and depth  $K_r$  can be calculated.  $K_r$  and Table 2.1 from the Concrete Handbook provided the  $\rho$  needed for calculating the steel area. Finding the eccentricity of the column lets the designer know if it is a slender column or not. Calculating the  $P_r$  allows for the calculations to be checked to see if the dimensions are appropriate. The full equation is seen here

$$P_r = 0.8P_{ro} = 0.8[\alpha_1\Phi_c f'_c (A_g - A_s) + \Phi_s F_y A_s]$$

The area of steel ( $A_s$ ) was next calculated using the table 2.1 from the Concrete Design Handbook. (Concrete Design Handbook.). Finding the  $A_s$  minimum then gave the number of bars to be used and the spacing of those bars.



## Results

The dimensions of the pedestals to be associated with the footings of tributary areas 1, 2, 4 and 5 are seen in Table 12: Pedestal Dimensions where the calculated reinforcing steel for concrete columns is seen in Table 13: Pedestal Reinforcing Steel.

Pedestal	Ag m <sup>2</sup>	b mm	d mm	H mm	As (min) mm <sup>2</sup>	spacing mm
1	0.25	500	150	1000	1000	140
2	0.25	500	150	1000	1000	140
4	0.25	500	150	1000	1000	140
5	0.25	500	150	1000	1000	140

Table 12: Pedestal Dimensions

Pedestal	Rebar		Ties	
	Bar Type	#	Bar Type	#
1	20M	4	10M	2
2	20M	4	10M	2
4	20M	4	10M	2
5	20M	4	10M	2

Table 13: Pedestal Reinforcing Steel

## Conclusions

Similar to the footing there will be 3 different pedestals used in the structure. They differ in their use of reinforcing steel and not their size as their footings already accounted for their width of 0.5 m.

### 3.10. Creation of Selected Design

Based on the specifications given by Stantec and the National Building Code of Canada, our team created a design to withstand Class C – Post Disaster conditions and the climate conditions of Sydney, Nova Scotia. These designs took into account the live, dead, wind, seismic, and snow loads.

Due to the importance of the transmission line, the transition building had to be built to handle a Class C – Post Disaster condition. All local conditions were brought to extremes and considered in the design process. While it might seem overzealous to make a building this robust, the effects of not having power in the aftermath of a natural disaster can be crippling, regardless of

the season. The sustainability of the design became one of the largest factors for the design. If it is designed for Post-Disaster conditions, one can reason that it will have an extended life time and low maintenance requirements.

### 3.11. Contrast between American and Canadian Loading Standards

While both the Canada and the United States use similar loading equations and systems, there are differences between the two which should be considered when designing a building. For this analysis, the 2010 National Building Code of Canada and Chapter 2 of Structural Steel Design 5<sup>th</sup> Edition were used. The steel book was published in 2012 and is reflective of the American Institute of Steel Construction, the American Society of Civil Engineers, and International Building Code (Page 40, 51). Below is a table showing a numerical comparison between the two standards. First, Table 14: Load Variables defines the variables used to consider the design load a structure must withstand.

Table 15: Load Development shows the equations used by the United States and Canada for specific load types. In general, Canadian standards require the buildings to be able to carry 70-100% of the factored load for buildings in the United States, as shown in the bottom right hand side of the table. The values given for the different variables are based on examples in the Steel textbook (Pages 55-57). These values are not representative of the project presented, but merely serve to help differentiate between the two systems.

Load Name	Variable	Values (kg/m)
Dead	D	450
Live	L	600
Wind	W	300
Rainwater	R	270
Snow	S	270
Live Roof	Lr	270
Earthquake	E	140

Table 14: Load Variables

Equation Number		Equations	Values (kg/m)	% of US
<b>1</b>	<b>USA</b>	<b>1.4D</b>	<b>630</b>	
	Canada	1.4D	630	100
<b>2</b>	<b>USA</b>	<b>1.2D+1.6L+0.5(Lr or S or R)</b>	<b>1635</b>	
	Canada	(1.25D or 0.9D)+1.5L+(0.5S or 0.4W)	1597.5	97.70642
<b>3</b>	<b>USA</b>	<b>1.2D+1.6(Lr or S or R)+(L or 0.5W)</b>	<b>1572</b>	
	Canada	(1.25D+0.9D)+1.5S+ (0.5L or 0.4W)	1267.5	80.62977
<b>4</b>	<b>USA</b>	<b>1.2D+1.0W+L+0.5(Lr or S or R)</b>	<b>1575</b>	
	Canada	(1.25D or 0.9D) + 1.4W + (0.5L or 0.5S)	1282.5	81.42857
<b>5</b>	<b>USA</b>	<b>1.2D+1.0E+L+0.2S</b>	<b>1334</b>	
	Canada	1.0D+1.0E+0.5L+0.25S	957.5	71.77661

**Table 15: Load Development**

The Canadian equations used were taken from Table 4.13.2A of the 2010 National Building Code of Canada. American equations were taken from Structural Steel Design 5<sup>th</sup> Edition (Page 53-54). As previously stated, Canadian Code requires the buildings to carry 70-100% of design load for a similar building in the United States.

These different equations allow for the engineer to be sure the building can withstand multiple loads at a time. This proposal goes into many more combinations than have been shown here. Additionally, the proposal covers unfactored loading. The coefficients preceding the variables are known as factors, giving each variable a higher or lower value based on the accuracy of predicting a load or the importance of planning for a particular load type. As the building is designed for a location in Canada, the 2010 National Building Code of Canada was used in the analysis.

#### **4. Sustainable Material Selection Process**

This section details the process of selecting a material out of the nine building materials considered in this project. The chosen material will comprise the bulk of the building structure and framework. The nine different materials were chosen by the project management team and notable sustainable materials found in research. They are reflective of the standard industry material and are typically used in construction. If a material is eliminated in this analysis, it does not mean it will not be a part of the final structure. This selection is only to determine the main building material for the framework and walls. Only one main material is chosen to make construction easier and faster.

Standard industry materials are compared first, then sustainable materials. To facilitate comparison, the analysis structure of each material is the same. The first section details what the product is and the company. The second talks about the functionality and cost investment. These terms are used interchangeably with durability, lifespan, and maintenance required. For the purposes of this project, one hundred years is the anticipated lifetime required. This is important because the building being designed has to last for a long time. The third discusses the sustainability factors. The last section summarizes the findings.

The research for this part of the project consisted primarily of reading online documents, supplementing these with e-mails and phone calls to representatives in the industry or companies. Notes were taken while reading these documents and their objectivity was considered. When the research and analysis was complete, a spreadsheet with different categories was used to score each material. The better a material was in a category, the higher the score.

#### 4.1. Typical Industry Concrete Masonry Units

Concrete Masonry Units (CMUs), are one of many concrete forms used in construction. CMUs are made of the normal concrete forms, but cast differently. These units are composed of fine and coarse aggregate, water, and Portland cement. They can also be called cinder blocks when some of the cement is replaced with fly ash (How Concrete Block is Made). Typical blocks are in rectangular form, with two hollow squares in it to allow for insulation, however variations exist demonstrated in Figure 16: CMU Types.

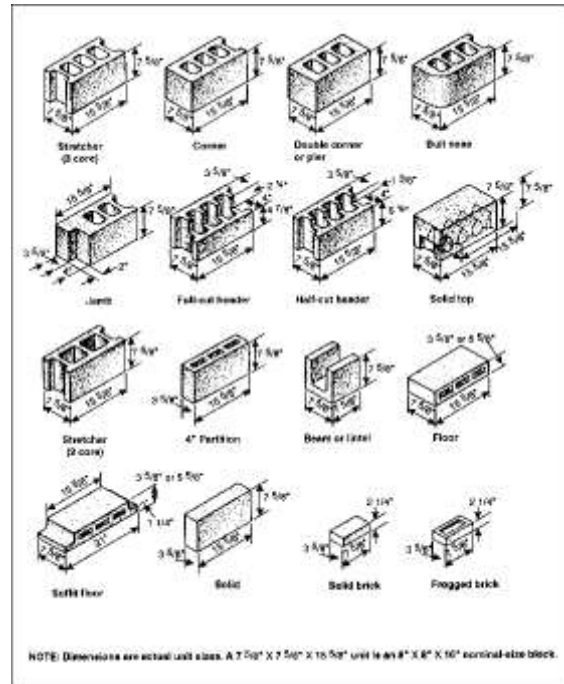

Figure 16: CMU Types (Heiserman)

The functionality, compatibility, and upkeep for CMUs are archetypal for concrete. CMUs have an expected lifespan of upwards of seventy five years (Estimated Life Expectancy Chart for Florida Homes). While the lifespan is for Florida, consider that Florida has coastal environments and also extreme weather including hurricanes. The ability to withstand harsh weather is key when considering the lifespan and the need for the building to stand the test of time. The required maintenance is low, due to the resilient nature of concrete. However, it is worth noting that while concrete may be highly resilient, whatever is used to hold the concrete blocks together may not be as durable. Therefore, regular inspections are important to maintain the quality of the concrete. Since the electrical equipment will most likely be inspected on an annual basis, the concrete can be inspected on the same basis. Reducing the need for inspections makes it possible to have a low maintenance and low cost building. These hardy properties are important for CMU to survive in the environment, though there are other factors.

These other factors include the impacts CMU has on the environment. In the manufacturing process, one ton of concrete releases one ton of Carbon Dioxide equivalent (CO<sub>2</sub>e) which increases the impact of global warming (Bremner 3). As concrete grows in use, the impact of these emissions will grow, also. If selected, this project would be utilizing concrete and

contributing to the emissions worldwide. It is possible to reduce the emissions by substituting fly ash for the cement. Fly ash improves the longevity of concrete and helps the environment at the same time. While it is possible to reduce the impact of CMU in this regard, the environment has many factors to consider.

Another factor is the materials required to make CMU. The materials for CMU are typically fresh, requiring new resources for every batch. With the exception of cement, the materials are readily available almost anywhere. However, if these materials are only used once, they end up in a landfill or serve no further purpose. Increasing the number of landfills or contributing to it has a detrimental impact on the environment. It is possible to recycle CMUs, but there is a cost. The recycling of CMU or other concrete involves a machine crushing the material into coarse and fine aggregate (Environmental Council of Concrete Organizations 1). If steel bars or other materials are used to reinforce the CMUs, they have to be removed in the process. The recycled content only uses crushed concrete, not any reinforcing material. There are two other important factors, strength and porosity. First, the strength of concrete with recycled material is 80-90% of fresh concrete. Second, the water absorption of concrete with recycled material increases 2-6% (Environmental Council of Concrete Organizations 2). This value may not seem like a large increase, but bear in mind the climate and the lifespan of the building. Even 2% over seventy years in a wet and cold environment could have a large impact. A building's structure of such importance cannot be left to chance. This is not to say CMU or concrete cannot be recycled and put to new use. There are numerous uses where recycled concrete would not be under the stress from this harsh climate. Therefore, the use of CMU in this project would require completely fresh material.

A new tool to measure environmental impacts is the Life Cycle Analysis (LCA), allowing for the study of a material like CMU over its lifespan instead of one particular phase. The LCA shows that the transportation and production of CMU is a small percentage of the total CO<sub>2</sub>e generated during the lifetime of use. This shows the importance of considering the big picture in building sustainably, and not just one part. The majority of the emissions generated come from the inefficiency of the building and building use (Marceau and Vandem 15). After examining the LCA of CMU, it became clear the blocks did not insulate well. The LCA was for a home in various areas, and the data cited here is from Minneapolis, Minnesota. A CMU home generates

2,200,000 kg of CO<sub>2</sub> during its 100 year lifetime (Marceau and Vandem 16). However, the study goes on to say 95% of the emissions are from operating expenses, which include heating (Marceau and Vandem 36). Therefore, if ignoring all the energy lost by the required heating and doing some basic conversions while accounting for the efficiency, the use of CMU blocks releases 2,420 pounds of CO<sub>2</sub> per year for one hundred years. While this number is small on the global scale, it represents a significant contribution to global warming. The heating cost also lines up with the R value, or insulation value, for CMU. CMU has a value of 1.28, which is fairly low (R-Values of Insulations and Other Building Materials). From this analysis, CMU has a large environmental impact.

CMU has many different attributes and detriments in its analysis. CMU is a strong concrete, capable of lasting as long as the client requires with minimal maintenance. Since it will last for a long time, it reduces the drain on resources. However, in the environmental analysis it becomes clear CMU has some drawbacks. Even after reducing emissions with fly ash, CMU does not insulate well and recycled material cannot be used in this location. While strength and maintenance are important, the huge drawbacks on the environmental side are an obstacle to using CMU.

#### 4.2. Typical Industry Precast Concrete

Precast concrete is another concrete form examined in this analysis. It is comprised of the typical ingredients in concrete and reinforced with rebar as needed. The distinctive characteristic of precast is that it is made using a mold off site. This allows for rapid construction, which makes it possible to enclose a structure and work independently of weather.



Figure 17: Precast Structures (Total Precast Concrete Structures)

Precast Concrete has moderate durability and upkeep requirements. Lifetime estimates are fifty to seventy five years, which is supported by studies done in Canada (Marceau and alia 2, 8). Regardless, it is still very durable. Mortar is used to hold the pieces together, but less mortar is required than brickwork. This means less mortar can be worn away, and less mortar will have to

be replaced. The less replacement is required; the lower maintenance costs will be. However, given the anticipated annual inspections for the electrical equipment, deformities in the concrete or mortar will be noted long before any required inspections. If it were used, precast concrete would be able to last for the time frame required.

The condition of its use would also depend on the impact precast concrete has on the environment. Precast concrete has similar drawbacks as CMU. It cannot be comprised of recycled material, nor can it be easily recycled after. Difficulty in recycling a material makes it more likely for it to be put in a landfill. Fly ash would be employed to reduce the CO2 impacts from production. An LCA of a commercial building in Toronto showed the building released 765.6 pounds of CO2e per square meter, after factoring the efficiency of the building. This is a moderate amount of CO2e, but the building consumption is around 89% (Marceau and alia 7). This indicates the insulation is less efficient, and the heating is still an important component of the building power consumption. Using energy to heat a building still involves emitting CO2e. The less energy required, the better it is for the environment. Precast concrete still has a lesser impact on the environment than CMU, but still one worth noting.

Precast concrete has many different attributes and detriments in its analysis. Precast concrete has the ability to last for the required period of time with minimal maintenance. Since it doesn't need to be replaced or maintained as often, it will reduce the drain on resources.

Environmentally, precast concrete has an acceptable LCA, but still requires extra insulation and is unlikely to be recycled. Precast concrete has good maintenance and durability factors, and moderate environmental factors.

### 4.3. Typical Industry Cast in Place Concrete

Cast in place concrete is unhardened concrete prepared off site and poured into molds on the project site. In order to use cast in place concrete, several molds, rebar, and scaffolding must be prepared. While this seems like additional effort, it allows for concrete to be made seamlessly. However, the nature of construction leaves the concrete vulnerable to the

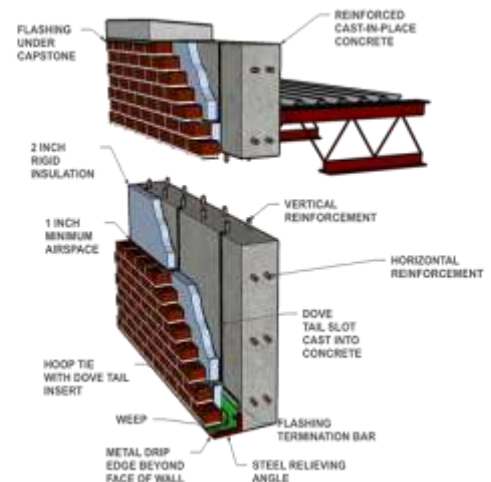

Figure 18: Cast in Place Concrete (Cavity Wall: Brick Veneer/Reinforced Concrete Wall)



elements since it is being constructed on site. If a storm were to come up while the concrete was hardening, it could set construction back and waste material.

Once hardened, Cast in place concrete is durable and expected to last for the duration of the project. It can last upwards of one hundred years, easily as long as needed for this project (Prec 2). The maintenance is along a similar line as before, allowing for the regular inspections. As there is no mortar, the expected cost of maintenance is much lower. Regular maintenance is still expected. Cast in place concrete has a very strong case for itself in the area of functionality and cost efficiency.

In the area of sustainability, cast in place has similar issues as the other concrete forms do. It will be made of all-new material, and be difficult to recycle with the rebar. Fly ash must be used to counter the emissions generated in making it. Unfortunately, no LCA data came up in the research on cast in place concrete, and therefore the discussion is based off the results of other concrete forms. Given that the concrete has no insulation and is a solid block, it most likely shares properties with precast concrete. Precast concrete has an acceptable LCA, but finding an LCA for cast in place concrete is still worth investigating. If the LCA is drastically different than suggested here, it might change the material selected. Regardless, cast in place concrete has a fair impact on the environment.

Cast in place concrete has many different attributes and detriments in its analysis. It has the ability to withstand the test of time and needs a minimal amount of care. The environmental impact is fair, but tolerable. Cast in place concrete has excellent lifespan and maintenance factors, along with fair environmental factors.

#### **4.4. Typical Industry Insulated Concrete Form**

Insulated Concrete Form (ICF) is becoming more commonly used in construction, due to many different attributes. ICF is concrete with rebar, insulating foams, polystyrene, wood fiber, and beads added. This combination gives the concrete new attributes not found in basic mixes. The concrete becomes nearly air tight, keeping sound and heat inside the building. ICF has an R



**Figure 19: ICF Interlocking Form (Walls)**

value of 40 m<sup>2</sup>K/W, a very high insulation value. In comparison, wood flooring has an R value of 9 and basic concrete R values range from 0.47-0.86 (Anderson 9, 14). The higher insulation value means energy savings. ICF resembles Legos in its building style, as the pieces interlock together with the use of pre-cut notches.

ICF is also noted for its great durability and low maintenance requirements. ICF can withstand brutal force from weather, standing up to indirect tornado damage, hurricanes, and other forces of nature with minimal damage (NAHB Research Center Inc. 2-4). The ability of a material to withstand a hurricane indicates it would be durable over a longer period with calmer weather. ICF also requires less maintenance over its 75 year lifespan (Estimated Life Expectancy Chart for Florida Homes). ICF has the interlocking ability, but still requires mortar to be held together. Equipment inspections and ICF inspections can be coupled, allowing for easy monitoring. Given the durability of the blocks in adverse conditions, the maintenance is expected to be low. ICF should be more than up to the challenge presented by the marine location.

In considering the environmental impacts, ICF has a few challenges and strengths. Since it is still concrete, fly ash ought to be considered in its production. This may not be an option if the bricks are pre-made without fly ash. If the bricks are pre-made, it will have a larger impact on global warming. It is necessary to make the ICF out of fresh material for integrity

purposes, and it cannot be recycled easily after. Polystyrene, one of the components, is Styrofoam. Styrofoam does not biodegrade. The Styrofoam and rebar make the recycling process difficult, as separating materials isn't as easy as separating Legos. On the other hand, ICF has a high insulation factor, giving it a very favorable LCA. Only one half to eight pounds of CO<sub>2</sub>e are released a year for seventy years for each square meter of space in the building, accounting for the 88-98% energy demand from building operations (Ochsendorf and alia 89). This high efficiency means less energy is wasted heating the building or is lost during the course of the year. ICF has a lower impact on the environment, but one that should not be overlooked.

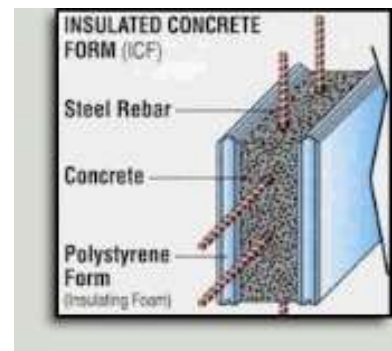

Figure 20: ICF Composition (Alter)

ICF has many different attributes and detriments in its analysis. It is sturdily built, requires minimal maintenance, and will be able to last until the building is abandoned. The use of ICF will be a one-time use and head straight for a landfill after, but has a favorable LCA. Insulated Concrete Form has good durability and maintenance factors, and moderate environmental factors.

#### 4.5. Typical Industry Structural Steel

Structural Steel is made of refined iron, carbon, and other elements. It is made with the Bessemer process before being cast into molds. Structural steel is distinguished from regular steel by its shape, which is useful for framework and other building components.



Figure 21: Structural Steel (Services)

Steel is durable, as evidenced by the skyscrapers looming over city skylines, but does require more upkeep than other building materials. Steel has a lifetime of upwards of fifty to over one hundred years (Estimated Life Expectancy Chart for Florida Homes). This range does give some concern, but proper care ought to keep the steel in the upper half of the estimate. Given that the steel is in a place where it will feel the effects of the marine environment, it will need to be properly cared for. The maintenance represents extra cost and labor not found in other materials. By coating the steel with a finish, it can last ten to fifteen years without any corrosion or the finish wearing off (Dr. Saha 10). For a worst case scenario, when the steel maintenance occurs, it will be a labor intensive process as the old finish will have to be stripped off, the steel surfaces cleaned, and the new finish applied. This has to be done in clear weather, as some finishes require three layers. Since this is a lengthy & labor intensive process, it will more expensive. While steel has a long life span, the maintenance can be rather intensive, giving it a moderate rating.

On the environmental side steel has a lesser impact. The steel production process can produce a large amount of CO<sub>2</sub>e based on the process used and the amount of raw material required. A half-ton to two tons of CO<sub>2</sub>e are released for every ton of steel based on the process (Birat 2). It also causes the water used to make it toxic. Increasing the toxicity of the environment destroys ecosystems and limits the drinking water supply. Steel can be made from recycled steel, and

retains the same strength, and often is. It also can be completely recycled, with minor losses in the process. Therefore, the same piece of steel can be used for centuries if recycled. Using the same material over and over reduces the need to manufacture more. By itself, the R value of steel is close to zero and requires additional insulation (How is the R-Value of Fiberglass Insulation Affected by Steel Studs?). This means steel would be used in conjunction with insulation. While a distinct LCA for steel is not cited, various LCAs comparing steel and concrete put steel and concrete roughly on par with each other (Zhang 8; Hsu 44; Johnson 113). Steel has a moderate impact on the environment.

Structural steel has many different attributes and detriments in its analysis. It is able to withstand the time requirements, but with some maintenance. In considering the environment, steel can be recycled and has a positive LCA, but has adverse effects on the water. Steel has moderate upkeep requirements and environmental impacts, but good durability factors.

#### 4.6. Sustainable Forms: Vulcraft (Structural Steel)

In pursuing the material research, multiple companies showed up as being committed to sustainability process while manufacturing needed building material Vulcraft is a structural steel company owned by Nucor. Nucor is the largest recycling company in North America (LEED). Its approach to manufacturing steel has set it apart from other steel manufacturers.

The steel functionality and investment is expected to be similar to other steel types. In a personal e-mail, a Vulcraft representative explained the steel structure could be designed for any lifespan required (Stanitsas). The expected care involves coating the steel with a finish, or use of a stainless steel.



Figure 22: Strong Steel (Engineers)

Stainless steel is better able to resist corrosion, making it a better choice in a humid environment. Coating the steel is effective, but represents additional cost. The long life span and moderate maintenance allow for a worthwhile return on investment with Vulcraft's approach.

The distinction in Nucor’s approach is the impact of manufacturing on the environment. Many steel companies have large impacts on the environment, including Nucor, which was ranked fourteen on the Toxic 100 list in 2004. This list shows the companies in the United States, and ranks them based on the amount of toxins released into the environment. Nucor had a score of 154,570 (Toxic 100 Index (2004)). This score is reached by multiplying the pounds released by the toxicity and the population exposed to it. Nucor changed policies, and was ranked 37 on the list in 2008, reducing its toxic score to 36,963 (Toxic 100 Index (2008)). Part of the success in reducing the score has to do with Nucor recycling the water in the steel manufacturing process and using electric arc micro mills. As an example, a mill in Darlington, South Carolina has its own water treatment plant recycling the water used at the mill. “To keep up with the mill’s demands, that the plant must collect, cool, treat, and recycle approximately 35,000 gallons of

water every minute. In one day, the treatment plant saves enough water to take care of the needs of a city of 500,000 people” (There's Not Much Left for the Landfills). As the water is



Figure 23: Vulcraft Products (Products)

recycled, there is no toxicity argument to be had. Since the water is recycled and not toxic, there cannot be an adverse impact on the environment. Further, Nucor generates less than a fifth to a quarter ton of greenhouse gas for each ton of steel manufactured (Hartnett and Ketellapper 7). Vulcraft already uses 70-97% recycled steel in the manufacturing process (Vulcraft Steel Joists & Joist Girders 11). This reduces the amount of raw iron that must be harvested each year to keep up with the demand and production for 25 million tons of steel each year (Nucor Steel). The steel can also be recycled when the building is decommissioned, further reducing the need for new steel. As few LCAs were available for the sustainable materials, the data of an LCA was not weighed heavily for this part of the analysis. It would be inconsistent to measure the materials by data only available to a few. Given the trend of steel, it ought to have a beneficial LCA. With Nucor’s approach, this structural steel has a minimal impact on the environment.

Vulcraft’s structural steel has many different attributes and detriments in its analysis. The steel can be built to last the required time, and can be covered with protective coating in order to

counter the marine effects. While maintenance is required, it will likely only occur seven to ten times over the course of a hundred years. On the sustainability side, the steel can be recycled and used many times over, presumably has a good LCA, and few adverse effects on the water other than consuming it. Vulcraft's steel has moderate functionality requirements, but great durability and sustainability factors.

#### 4.7. Eco Smart (Cast in Place Concrete)

EcoSmart Concrete is another material that showed up in the research as a company committed to reducing impacts on the environment while still producing a useful building material.

EcoSmart makes cast-in-place (CIP) concrete, and is a Canadian based company (EcoSmart Homepage). Since it is Canadian, the company will have more experience working with the Canadian National Building Code. EcoSmart's home page is geared towards the environmental impacts of the building material, distinguishing it from other competitors in the market.



Figure 24: Versatile & Varied in Use (Environmentally Friendly Construction)

Unfortunately, the level of detail on the EcoSmart page about the functionality and investment is low. However, as the amount known about CIP concrete is high, the relevant data can be inferred. If chosen for the final building material, all inferred data would need to be confirmed by the company. CIP can last upwards of one hundred years and will need inspections to monitor for cracks. As the lifetime greatly exceeds the expected usable life, the need for maintenance is unlikely. Low maintenance means lower cost. A discussion with an EcoSmart representative included a Hindu temple in Hawaii with foundations specified for five hundred years with no maintenance requirements (de Spot). The building would not have to last near as long to fulfill its service life in Nova Scotia. EcoSmart's CIP concrete has functionality and cost efficiency properties greatly exceeding the requirements of the project.

On the environmental side, EcoSmart also distinguishes itself from the competition. EcoSmart concrete replaces 50% of the Portland cement with fly ash (EcoSmart Homepage). This takes a large chunk of the emissions out of the manufacturing stage, and helps to protect the environment. It will, however, still require reinforcing steel and fresh material, with no guarantee of being able to recycle the material at the end of the project. An LCA study was not considered for this material. All sustainable factors considered; EcoSmart CIP concrete has a fairly helpful rating.



Figure 25: EcoSmart Concrete (Concrete\*enthusiast)

EcoSmart concrete has many different attributes and detriments in its analysis. This formula will be able to easily last as long as required with virtually no maintenance. Environmentally, it has a fairly helpful rating. EcoSmart concrete has an excellent lifespan, low maintenance, and fair to good sustainability factors.

#### 4.8. Sustainable Forms: Ductal

Ductal is an Ultra High Performance Concrete (UHPC) made by Lafarge, and has come up in the sustainability research. It has similar properties to precast concrete, and the approach of the company is to make a long lasting concrete and reduce the material demand. Lafarge is a French based company, but has a Canadian base of operations in Calgary (Contacts). Despite the distance from Alberta to Nova Scotia, this indicates the company will have more experience working in Canada. Lafarge's product has notable properties distinguishing it from other concrete forms.



Figure 26: Durable Ductal Concrete (Ductal Advantages)

When it comes to the investment and functionality factors, Ductal is high on the charts. The site advertises the material as having self-healing properties (Material Made to Last). The website says it would take Ductal a thousand years to reach the same level of chlorine penetration as a

normal concrete would have in a hundred years (Sustainable Development). Resistance of this level shows the concrete would be able to stand up to the problems presented by the chlorine-rich

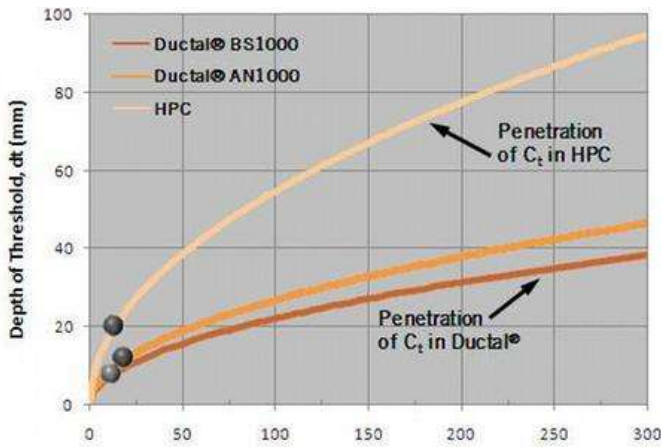

Figure 27: Ductal Life Projections (Sustainable Development)

marine environment. Even though there is no case study available to show the actual life span and the concrete formula for a standard concrete isn't given, the claims are spectacular. Despite with simulations and case studies, it is still difficult to be sure the concrete will perform as stated.

Regardless, even if the projections were only correct to a tenth, it would more than cover the required time for this project to

last. It also seems unlikely for an international company to base its reputation on something inaccurate. Given the lifespan and healing factor, the maintenance would be reduced to almost nothing. Therefore, Ductal has excellent maintenance and durability factors.

On the environmental side, Ductal makes a few distinctions from other concrete, but is otherwise typical. It is composed of about 30% Portland cement, which is a large component, and therefore means a large amount of emissions. Ductal requires no steel reinforcement, making it easier to recycle (Ductal Advantages). Fresh material will be required to make the concrete with full strength. An LCA was not considered for this material. While more easily recycled, Ductal still has a noticeable impact on the environment.

Ductal has many different attributes and detriments in its analysis. The long lifespan and low maintenance requirements of Ductal are greatly in excess of the project needs. The environmental impacts are moderate, making it roughly the same as typical concrete forms. Ductal has good compatibility and cost efficiency factors, but moderate sustainability effects.

#### 4.9. Sustainable Forms: FasWall

FasWall is an ICF variant made by Shelter Works in Oregon, and is the final



Figure 28: FasWall & Shelterworks Logos (FasWall Home)



material considered in the sustainable materials. One of Shelter Works' owners formerly worked for Habitat for Humanity (Team). FasWall is composed of 85% wood-based product and 15% cement (6SpecSheets). The construction process and characteristics of Faswall make it distinct from other concrete forms or building materials.

In terms of functionality and investment, FasWall amply meets the needs for this project. It has a projected lifetime of two hundred years and low maintenance requirements (Compare FasWall). It has typically been used in home building, but has been expanding to commercial building in recent years (Van Denend). It will also be able to withstand the coastal environment, with success stories from coastal Maine as testament (Van Denend). As it is an ICF, it will require mortar. Typical inspections and upkeep are expected to follow. The expected upkeep means there will be costs to the owner. FasWall has great durability and cost efficiency.

From a sustainability standpoint, FasWall has a lot going for it. Of the cement used, 30% is clinker, or leftover limestone and other rocks or minerals. The remaining 70% is Portland cement. Fly ash is not used due to customer concerns (Van Denend). The composition of the block could probably be changed to fly ash for a large order. As the bricks are made of wood product, the material is replaceable and also made of 10% recycled material (Van Denend). FasWall has a high R



Figure 29: FasWall Block (FasWall Home)

value of 21 to 25.5 (6SpecSheets), which is not as high as other ICF forms. This means the insulation of FasWall is not as high and more heat will be lost from the building. Anecdotal evidence says heating costs in homes were cut 50% after using FasWall, showing the insulation value still has great impact (Van Denend). When bricks are broken, most contractors break them up and bury them on or near the site. Alternatively, it is possible to ship them back to the company for the broken bricks to be recycled in a later batch. FasWall has an excellent sustainability rating given its minimized impact on the environment.

Faswall has many different attributes and detriments in its analysis. The components and structure of FasWall give it the durability to last with little care. The number of steps taken to ensure a minimal impact on the environment is a further testament. FasWall has good durability, good maintenance, and excellent sustainability factors.

#### 4.10. Final Material Selection

In processing the many different building forms to decide on the best type, a number of different tools were used. Among the tools was the website Building Green, which catalogs and stores different environmentally friendly building materials. These databases helped to identify some

Please note: Industry scores and sustainable scores were determined independently of each other. Compare data when comparing the two							
Durability & Lifespan		Required Maintenance		Environmental Impact			
Industry Material	Data	Score	Data	Score	Data	Score	Total (of 15)
Cast in Place Concrete	100+	5	N/A	4	2	2	11
Pre-Cast Concrete	50-75	2	N/A	4	2.25	3	9
Structural Steel	50-100+	4	10-15 years	3	3.5	5	12
Insulated Concrete Form	75+	3	N/A	5	2.75	4	12
Concrete Masonry Unit	75+	3	N/A	4	1.75	1	8
<b>Sustainable Material</b>							<b>Total (of 14)</b>
Ductal (UHPC)	1000	5	Very low, self	5	2	2	12
Ecosmart Concrete (CIP)	Default, unknown	2	Default inspec	4	2.25	3	9
Vulcraft (SS)	50-100+	3	10-15 years	4	3.75	5	12
Faswall (ICF)	200	4	Default inspec	4	3.25	4	12

Table 16: Material Analysis Spreadsheet Results

of the products identified in this report. While the database cannot be expected to be all inclusive, it served as an auspicious starting place as an independent group monitoring the industry.

Another tool was the spreadsheet found in its entirety in Appendix E and in part above, which originated from the Project Management team as a means of ranking materials. It was adopted and reformatted to suit the purposes of this team. The three categories are the same criteria given earlier in the paper and touched upon in the analysis. The numbers and rankings correspond to the analysis given in the paper. The scores are determined by place and performance. The best material in a category received a 5, second best a 4, and so on. Ties share scores. The materials with the higher scores are better. For example, a material with a hundred year lifespan would get a 5 if no other material had a longer lifespan. If there was one other material with a longer lifespan, the hundred year lifespan material would get a 4 instead. Further, the good or favorable materials ranked 4 or 5, while moderate or poor materials were given 3 or lower in the respective categories. The numbers and rankings were decided upon by the team after researching and consideration when simple comparison was not enough to distinguish one product from another.

Typically, the sustainability scores were the ones with the most input from the authors, and are shown in Table 17. The scores correspond to the same materials as in the prior Table 16.

Author input was especially the case with the Life Cycle Analysis (LCA) scores. As this was the first time being exposed to an LCA, it was daunting to go through multiple hundred page reports looking for conclusions. It was also challenging to have the reports fogged by their respective authors when it came to reaching honest conclusions. “Because impact categories are being compared to one another, and importance is assigned based on factors chosen by the researcher, it is easy to manipulate the process to downplay certain impact categories or favor one product if an accounting LCA is being performed” (Hsu 15). This statement came from the LCA comparison and analysis done by an MIT student. It was among the more objective and honest among the reports examined, and conveys the difficulty with using an industry LCA. After numerous shortcomings with industry-based LCAs comparing two different building materials, it

<b>(Scoring, (0-1, 1 is best))</b>						
<b>Environmental Breakdown</b>						
Resources required	LCA	Recycle	Toxic or Hazardous to make?	Lifespan	Data	Score (1-5)
0.25	0	0.25	0.5	1	2	
0.25	0.25	0.25	0.5	1	2.25	
0.5	0.75	0.75	0.5	1	3.5	
0.5	0.75	0	0.5	1	2.75	
0.25	0	0	0.5	1	1.75	
<b>(Scoring, (0-1, 1 is best))</b>						
<b>Environmental Breakdown</b>						
Resources required	LCA	Recycle	Toxic or Hazardous to make?	Lifespan	Data	Score (1-5)
0.25	0	0.25	0.5	1	2	
0.5	0	0.25	1	0.5	2.25	
1	0	1	1	0.75	3.75	
1	0	0.5	1	0.75	3.25	

**Table 17: Environmental Comparison**

was decided to only take the numbers from the company’s product and not any compared product. This was to protect the neutrality of this research. As the company product invariably won the analysis regardless of the material, this decision was logical.

However, it must be clear that one, two, or even five LCA's done on a material; it is not the final word. Until objective LCA's are consistently presented, one analysis is not enough to rule in favor or rule out a material. Even an objective LCA should be reinforced by other, equally objective research. The best analyses found in this research were done by independent agents with no industry ties or sponsorships. A similar trend can be expected in further research and other industries. All of this consideration and sifting was necessary to reach a conclusion on the final building material.

As the field of materials is rather large, the team made sweeping cuts to prune out materials not worth examining in further detail. Based on the spreadsheet, any industry material with a score less than three in any category is eliminated. This leaves structural steel and ICF. Both materials meet the functionality requirements, and the analysis turns to the environmental side. Structural steel can release a large amount of greenhouse gas, requires a lot of water to make, and makes the water toxic in the process. On these grounds, it is removed. ICF contains Styrofoam. As traditional ICF blocks become more widely adopted, it increases the production of and landfill concentration of Styrofoam. Landfills ought to shrink, and thus ICF is rejected. Industrial practices on the standard level are not on par with the level of quality the sustainable solutions offer.

With only the sustainable solutions remaining, the team went further in depth with the analysis of the material. As all the materials will meet the functionality and investment requirements, the sustainable criteria will be the deciding factor. EcoSmart concrete, while it uses fly ash and is geared towards the environment is eliminated as it requires fresh material and would be difficult to recycle. This left the team to sort through the remaining three materials, all of which have the same score.

It would seem the self-healing concrete said to last a millennium would be the obvious choice, but this is not so. The team examined the overall use and cost of Ductal to the environment. Ductal requires completely fresh material and a high concentration of Portland cement. While it could be recycled later, the question of whether it will be used is another question. Ductal makes no mention of recycled content. While the lifespan and maintenance requirements are impressive, there is little need. This building will not need to last longer than one hundred years, and thus Ductal is overqualified for this project. If the building were one of great cultural

importance, constructing a building for the ages would make sense. Over a millennium, the CO<sub>2</sub>e would amount to nothing. During this century, reducing the emissions by all means possible is more important. While a strong suitor for another project, Ductal is removed from consideration in this one.

FasWall and Vulcraft steel will be juxtaposed in the last bit of the analysis to show the thought process. These two materials are similarly ranked, with Vulcraft having the edge in sustainability and FasWall having the edge in lifespan. Both companies have taken great strides to ensure their material is of high quality and environmentally friendly. Vulcraft's representative stated it was possible to have structure designed for any lifespan required (Stanitsas). FasWall



**Figure 30: FasWall Project in Progress (FasWall Home)**

bricks can be recycled when broken or when a project is over, but requires shipping back to the company in Oregon. Recycling can be done locally, should an interested party be

found. Steel has no location issues when it comes to recycling, as Nucor is all over North America. In furthering the analysis, the team found the ability to recycle was contingent on location, and Vulcraft had the advantage.

Proximity to resources and supplies makes or breaks a project's speed. FasWall bricks would have to be shipped by train from Oregon to Nova Scotia. There are numerous trains constantly running from one end of the country to another. Over time, the transportation emissions average to very little. The real cost in shipping is not in emissions but in dollars and delays. Speaking of cost, the time required to erect the building using ICF requires two weeks more than steel. This is important because it means two weeks of construction costs must be paid for and not being able to collect payment for providing services. The overall cost is lower, but the delay is a detriment. In contrast, Vulcraft has a plant in New York. Supplies would be much faster in coming to the project site. This is especially important if there are material shortages or weather. The further a material has to travel, the more delays there can be. If there is a problem with a shipment, it must be replaced and distance acts as a barrier in these cases. The ability of Vulcraft to ship material faster and for a lower emission and dollar cost will pay off in the long run. Steel

continues to gain the upper hand as the team continued the analysis when considering location and cost.

Furthering the analysis is the performance of Vulcraft steel and FasWall during their useful life.

FasWall has superior insulation properties, allowing for reduced heating costs. Given the cold



**Figure 31: Vulcraft Track Record (Owners)**

climate, this is a useful trait to have. Steel is very heat conducive, and will require insulation to be added. While the insulation chosen could be environmentally

friendly, it is still additional material.

FasWall does not require much maintenance. Steel must be coated with protective material and monitored for corrosion, which could threaten the integrity of the building. However, Vulcraft has a history of being used in commercial settings, and FasWall does not. Even though it is categorized and treated as an ICF, which is acceptable for commercial use, FasWall has not established itself outside of residential building as of yet. In its defense, FasWall does have 25 year track record in residential building (FasWall Home). An entrepreneur might suggest choosing FasWall anyway to see how it did. However, if the building was compromised, power to the region would equally be compromised. The team concluded FasWall cannot be used on a trial building for something of this nature. While FasWall has noted advantages in performance, Vulcraft's steel has the edge in performance life. FasWall is therefore eliminated.

It is for these reasons, the ease of recycling, the completion time, and proximity of the material, and a solid service record that Vulcraft Steel is selected by the team as the primary building material. The maintenance and insulation requirements of steel are noted, but considered acceptable given the other qualifications and upkeep anticipated for the machinery inside.

#### **4.11. Waterproof Roofing**

The process of waterproofing roofs sometimes employs ethylene propylene diene monomer rubber (EPDM). The process of making a roof waterproof or water resistant consists of multiple steps. The process described will be the process used by Carlisle Syntec Systems. First, the roof deck has to be approved (Carlisle 3). Presumably, this is for loads and structural integrity.

Insulation is put on top of the deck, followed by fasteners and plates to keep everything in place. Bonding adhesive is put on top of the plates, fasteners, and insulation. Lastly, the EPDM

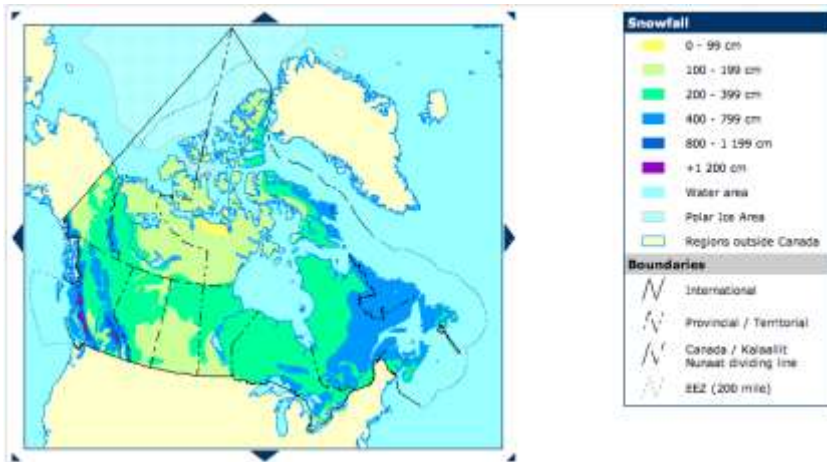

Figure 32: (Snow: Story of the Snowflake)

membrane is put on with Factory-Applied Tape (FAT) (Carlisle 2, 3). This process helps to protect the structure from rain, snow, hail, wind, and other weather.

Based on company criteria of using an EPDM Roofing made by Carlisle Syntec Systems, the search was

relatively short and only yielded one result.

Thus, there will be little analysis, but a discussion of how to best incorporate a sustainable material into the building. The material selected is the Sure-White EPDM roofing. As it is white and will reflect sunlight, the question of whether the heat retained in the building will be sufficient during colder months. First, consider the building will be generating heat from the machinery as well as the HVAC systems. Second, consider the building will have insulation, including the Sure-White roofing. Sufficient insulation reduces the need for heating. Third, consider that the roof may be covered by snow, making the color of the roof extraneous. Fourth, the length of the day is shorter in the winter and the sun is shining less directly on the earth (Duro-Last Roofing; RTN Roofing Systems). This means the benefit of having the roof absorb heat is reduced. Further, as this is in a wooded area, any tall trees may block the sun also. During the summer, the days are longer and the sunlight will be more direct. The energy benefits of having a white roof outweigh the reasonable color concerns.

#### 4.12. Walls & Insulation

If Vulcraft does not provide sheets for walls, precast EcoSmart concrete is recommended. It is chosen over Ductal or other materials. EcoSmart is familiar with Stantec practices and uses more fly ash in the manufacturing than Ductal. Regardless of the wall material, insulation is needed. Using the specifications provided, the company should use Foamglas. It is made by an international company and has a headquarters in Pittsburg. The material is non-combustible, resistant to compression, water and vapor proof, resistant to insects, and chemically resistant.

The R value is 3.4 per inch (Foamglas Home Page). Based on the criteria given by the company, the remaining materials will be fulfilled by standard industry materials.

#### **4.13. Innovation & Add-ons**

Some add-ons for the project were considered, but none are suggested due to the constraints and the location of the building. Solar panels could provide some useful power to the community nearby, but would require constant maintenance in the winter to keep the panels free of snow. In order to save energy, water could be run through the building to absorb heat in the summer, and later run into homes. However, the consequences of water leaking in an electrical facility far outweigh the benefits. Motion sensors to regulate lighting would be worth considering if the building was going to be active on a regular basis. The building's remote location, nature, and lack of a caretaker make it a poor choice for most add-ons.

### **5. Final Deliverables**

At the end of the time with Stantec the team aims to present two documents, one for the Capstone Design Requirement of the university and one for the final design of the Transmission Station for Stantec, and a final presentation summarizing the team's conclusions. The documents cover the design requirements and cost estimate for the Transmission Station. A formal presentation was made to detail the methodology, design aspects and final conclusions. For Worcester Polytechnic Institute the students also presented the findings in a poster presentation. The following chart categorizes these deliverables see Figure 33: Deliverables.

#### **5.1. Proposal Paper**

The team prepared the report to explain why the project is needed and how it was completed. This paper was written on a week-by-week basis in order to allow for revision. The team explained all relevant details to the process so it could be duplicated and understood.

#### **5.2. Presentation**

The team prepared an oral presentation, supplemented with a poster and slide show when needed, to explain the design project to the Stantec and WPI community. The team summarized the project and brought out key components. These points were decided on by internal discussion among the WPI teams as well as discussion with the Stantec teams.



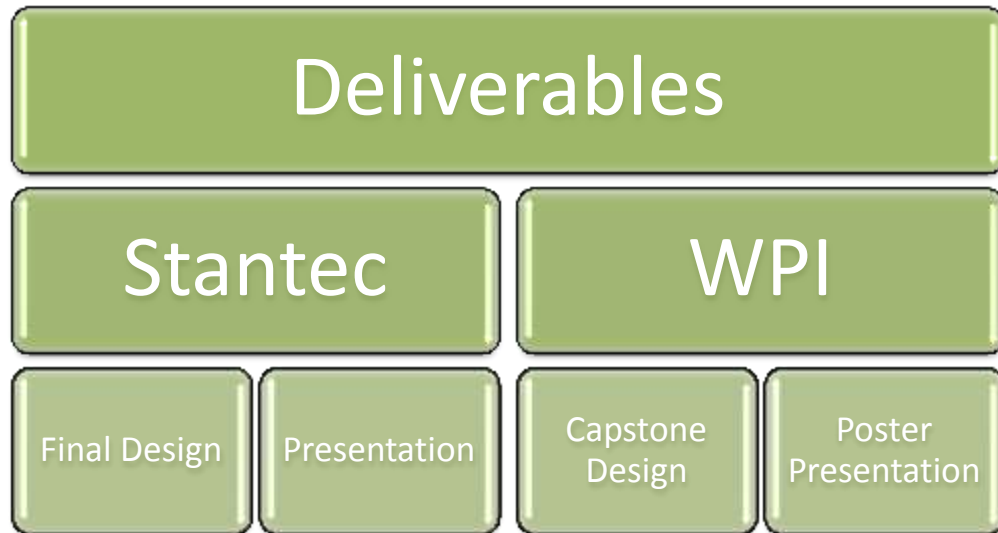

Figure 33: Deliverables

## 6. Final Results

Structural design and sustainability go hand in hand. A building meant to last an extensive time has long-lasting impacts. Two independent approaches, sustainable and structural analyses, have come to the same conclusion, reinforcing each other through research and calculation.

Addressed through similar topics, as the Capstone Design Statement and the LEED evaluation criteria, the results are categorized as falling into four main topics: Sustainability, Functionality, Cost and Innovation.

The structural design provided calculations to demonstrate that a building in order to withstand the assumed apocalyptic events would need to be somewhat over-designed and have not fully optimized members; seen in components like the foundation which is designed to withstand the full moment of the top of the steel column that it is attached to. The roof has the assumed ability to resist the uplift of extreme wind and weight of a tremendous snow load. The materials purposed in the sustainable materials section were all discussed to have the quantitative trait of a long life-time, meaning they also possess the ability to be quite durable, thus having the capability to withstand the same assumed extremes of the structure.

Understanding that the structure is for industrial purposes it has simplified functions i.e. minimal heating and ventilation systems, no plumbing and a complete lack of windows. This aids in the constructability from the aspect that there will be far fewer workers on-site and mostly major

components being constructed together. The design accounts for this in its simple structure, where the materials acknowledge functionality in their ease of constructability.

Cost was addressed in the materials section as what will produce the most return on a low investment. The structure of the building was intended to minimize the amount of material used and to keep the total cost low.

The sustainable materials section covered innovation in detail as it addressed any add-ons applicable to this project; however, innovative practices for this project were at minimum because its industrial purposes required little to no add-ons. Making a project green or sustainable isn't always adding on special features, sometimes it's making the building materials differently. In this way, structural integrity is not compromised. Sustainable research shows ways to produce the same structure with a smaller impact on the environment.

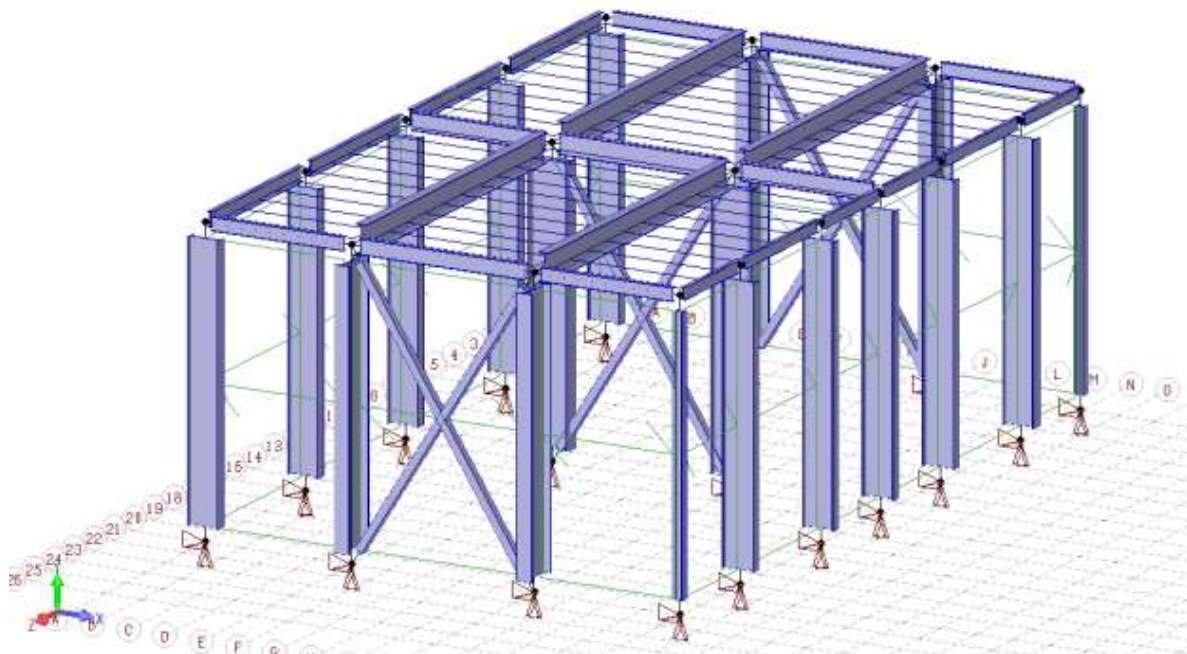

Figure 34: 3D SAFI Model

## 7. Conclusions

The proposal is to provide a conclusive inventory of possible materials that will satisfy the conclusions of the structural design and sustainable materials section.

As evidenced by the two independent approaches, steel is the choice material for the skeleton of the building. The foundations will consist of reinforced concrete. Joists and metal decking will be additional steel. These materials are not as specific as the ones to be used on the structure for specific sustainable purposes, because they are not new to the industry and do not offer the same green variants. The dimensions and sizes were still selected by careful research and calculation. The process is detailed in the methodology and explains how and why the conclusions came about. Specific materials with the promise of longevity are called out with the reasoning for selection summarized.

The sustainable material research consisted of nine different building materials for the skeleton. Concrete Masonry Units (CMU), cast in place concrete, precast concrete, Insulated Concrete Forms (ICF), and structural steel were the basic industry based materials. In order to consider the difference between normal industry practices and industry practices, EcoSmart concrete, Ductal Ultra High Performance Concrete, Vulcraft structural steel, and ShelterWorks's FasWall (ICF) were all considered as companies with a sustainable approach.

There were no appropriate innovations to add to the building. The main structural material selected is Vulcraft Steel. The roof will include Carlisle Sure-White EPDM material. Walls will be made by either Vulcraft or EcoSmart. The insulation will be made by Foamglas.



**Appendix A: Week Detailed Task Chart**

**Appendix B: Goals**

**Appendix C: Hand Calculations**

**Appendix D: Excel Calculations**

**Appendix E: Material Selection**

**Appendix F: Proposal**

**Appendix G: Presentation and Poster**

**Appendix H: Design Criteria**

## Works Cited

- "Our Products and Services / Canam.". 2009. 1 February 2013.
- "6SpecSheets." 2012. FasWall. Shelter Works. 4 Feb 2013.
- Alter, Lloyd. "Insulated Concrete Forms: Another Opinion." 3 April 2007. TreeHugger. 4 Feb. 2013 <Treehugger.com>.
- Anderson, Brian. Conventions for U-Value Calculations. 2006. 18 Jan 2013 <BRE.co.uk>.
- Birat, Jean-Pierre. "The ULCOS Program, CCS and Mineral Carbonation using Steelmaking Slag." 2009. Ultra Low CO2 Steelmaking. 19 Feb 2013 <ulcos.org>.
- Bremner, T. W. "Environmental Aspects of Concrete: Problems and Solutions." 2001. Universtiy of New Brunswick. 18 Jan 2013 <unb.ca>.
- Carlisle. "Sure-White Brochure." 2013. Carlisle Syntec. 11 Feb 2013 <Carlisesyntec.com>.
- "Cavity Wall: Brick Veneer/Reinforced Concrete Wall." 2009. MasonrySystems.org. 6 Feb. 2013 <mso.simpleapp.net>.
- "Compare FasWall." 2013. Shelter Works. 4 Feb 2013 <FasWall.com>.
- Concrete Design Handbook. Ottawa: Cement Association of Canada, 2006.
- "Concrete\*enthusiast." 2008. Concrete Enthusiast. 6 Feb. 2013 <concreteenthusiast.blogspot.ca>.
- "Contacts." 2012. Lefarge. 18 Jan 2013 <Ductal-Lefarge.com>.
- de Spot, Michel. Research 31 Jan 2013.
- Dr. Saha, Jayanta. "Cost Effective Ways to Protect Steel Structures from Environments." 2013. Institute for Steel Development & Growth. 4 Feb. 2013 <Steel-insdag.org>.
- "Ductal Advantages." 2013. Lefarge. 4 Feb 2013 <ductal-lefarge.com>.
- Duro-Last Roofing. "Black Roofs vs. White Roofs." 2013. Duro-Last Roofing, Inc. 12 Feb 2013 <duro-last.com>.
- "EcoSmart Homepage." n.d. EcoSmart Concrete. 2013 Feb. 4.
- Emera. The Maritime Link. 2012. 14 December 2012 <<http://www.emeranl.com/en/home/ourbusiness/aboutthemaritimelink/default.aspx>>.

Encyclopedia Britannica. "Reinforced Concrete." 2013. Encyclopedia Britannica. 18 Feb 2013 <britannica.com>.

"Engineers." n.d. Vulcraft. 5 Feb. 2013 <Vulcraft.com>.

Environmental Council of Concrete Organizations. "Recycling Concrete Saves Resources, Eliminates Dumping." 1997. Pollution Prevention Resource Exchange. 4 Feb. 2013 <P2RIC.ORG>.

"Environmentally Friendly Construction." 30 Jan. 2013. City of Burnaby. 5 Feb. 2013 <burnaby.ca>.

"Estimated Life Expectancy Chart for Florida Homes." 2013. International Association of Certified Home Inspectors. 4 Feb 2013 <NACHI.org>.

"FasWall Home." 2012. FasWall Organic Building Materials by ShelterWorks. 6 Feb. 2013 <faswall.com>.

"Foamglas Home Page." 2012. Foamglas. 19 Feb 2013 <foamglas.us/building/home>.

Handbook of Steel Construction. Cisc-Icca, 2001.

Hartnett, Nick and Matt Ketellapper. "Nucor NUE 2011 Ketellapper Hartnick Report." 7 April 2011. Leeds School of Business, University of Colorado, Boulder. 19 Feb 2013 <Leeds-faculty.colorado.edu>.

Heiserman, David L. "Concrete & Masonry." 2009. Free Education Network. 6 Feb 2013 <free-ed.net>.

"How Concrete Block is Made." 2013. How Products are Made. 2013 Feb 2013 <madehow.com>.

"How is the R-Value of Fiberglass Insulation Affected by Steel Studs?" 2013. Dow Cemical Company. 4 Feb. 2013 <Dow-Styrofoam.custhelp.com>.

Hsu, Sophia Lisbeth. "Life Cycle Assessment of Materials and Construction in Commercial Structures: Variability and Limitations." 2013. Massachusetts Institute of Technology. 4 Feb. 2013 <stuff.mit.edu>.

Johnson, Timothy Werner. "Comparison of Environmental Impacts of Steel and Concrete as Building Materials Using Life Cycle Assessment Method." 2013. Massachusetts Institute of Technology. 4 Feb. 2013 <dspace.mit.edu>.

"LEED." 2013. Nucor Corporation-Our Responsibility-The Environment. 6 Feb. 2013 <Nucor.com>.

LEED 2009. 2009. December 14 2012 <http://www.usgbc.org/ShowFile.aspx?DocumentID=5546>.

Marceau, M.L. and et alia. "Life Cycle Assessment for Sustainable Design of Precast Concrete Commercial Buildings in Canada." 4 Feb. 2013. Precast Prestressed Concrete Institute. 4 Feb. 2013 <CPCI.ca>.

Marceau, Medgar L and and Martha G. Vandeem. ""Comparison of the Life Cycle Assessment of a Concrete Masonry House and a Wood Frame House." n.d. Carolinas Cement Company. 4 Feb. 2013 <carolinacementproject.com>.

"Material Made to Last." 2013. [Lefarge](#). 4 Feb. 2013 <Ductal-Lefarge.com>.

Mitchell, Denis. "Comparison of CSA A23.3-94 with ACI 318-02." 26 October 2002. [American Concrete Institute](#). 12 Feb 2013 <Concrete.org>.

NAHB Research Center Inc. "Cost and Benefits of Insulating Concrete Forms for Residential Construction." Nov. 2001. [U.S. Department of Housing and Urban Development](#). 18 Jan. 2013 <huduser.org>.

"Nucor Steel." 2009. [Nucor](#). 4 Feb. 2013 <Nucortrading.com>.

Ochsendorf, John. and et alia. "Methods, Impacts and Opportunities in the Concrete Building Life Cycle." 31 Aug. 2011. [Massachusetts Institute of Technology](#). 18 Jan. 2013 <MIT.edu>.

"Owners." n.d. [Vulcraft](#). 6 Feb. 2013 <Vulcraft.com>.

Portland Cement Association. "Cement & Concrete Basics: Prestressed Concrete." 2013. [Portland Cement Association](#). 18 Feb 2013 <cement.org>.

Prec. "Benefits for Builders and Developers." 2013. [Precise Forms, Inc.](#) 4 Feb 2013 <Preciseforms.com>.

"Products." n.d. [Vulcraft](#). 5 Feb. 2013 <Vulcraft.com>.

RTN Roofing Systems. "A Black or a White Roof? - That is the Question." 2013. [RTN Roofing Systems](#). 12 Feb 2013 <rtn.roofing.com>.

"R-Values of Insulations and Other Building Materials." 2013. [Arch Tool Box](#). 2013 Feb. 2013 <archtoolbox.com>.

Salazar, Guillermo. [Project Management](#) 18 Feb 2013.

"Services." 2011. [Illinois Valley Fabricators](#). 6 Feb. 2013 <lvfab.com>.

"Snow: Story of the Snowflake." 2011. [Some Good Adventure](#). 12 Feb 2013 <somegoodadventure.com>.

Stanitsas, Gerry. [Re: Product Specifications](#) 31 Jan. 2013.

"Sustainable Development." 2013. [Lefarge](#). 4 Feb 2013 <Ductal-Lefarge.com>.

"Team." 2012. [Shelter Works](#). 2013 Feb. 2013 <FasWall.com>.

"There's Not Much Left for the Landfills." 2013. [Nucor](#). 4 Feb. 2013 <Nucor.com>.

"Total Precast Concrete Structures." 6 Feb 2013. [Canadian Prestressed Concrete Institute](#). 6 Feb. 2013 <CPCI.ca>.

"Toxic 100 Index (2004)." 22 Jan 2013. [Political Economy Research Institute: UMASS](#). 4 Feb 2013 <Peri.umass.edu>.



"Toxic 100 Index (2008)." 22 Jan. 2013. Political Economy Research Institute: UMASS. 4 Feb. 2013 <Peri.umass.edu>.

Van Denend, Thomas. Telephone Interview 1 Feb. 2013.

"Vulcraft Steel Joists & Joist Girders." n.d. Vulcraft. 4 Feb. 2013 <Vulcraft.com>.

"Walls." n.d. Ireland's House & Garden. 6 Feb. 2013 <idevelop.ie>.

Zhang, Xu., Xing Su, & Zhijia Huang. "Comparison of LCA on Steel- and Concrete- Construction Office Buildings: A Case Study." 30 Jan 2013. International Network for Information on Ventilation and Energy Performance. 4 Feb. 2013 <Inive.org>.