

Designing a Sustainable Outdoor Shower at Turn Back Time Farm

An Interactive Qualifying Project submitted to the Faculty of
WORCESTER POLYTECHNIC INSTITUTE
in partial fulfillment of the requirement for the
degree of Bachelor of Science

By:

Aaron McCutcheon

Andy Moise

Dalila Jarvis

Zachary Denbow

13 May 2020

Report Submitted to:

Professor Elisabeth Stoddard

Professor Derren Rosbach

Worcester Polytechnic Institute

This report represents work of WPI undergraduate students submitted to the faculty as evidence of a degree requirement. WPI routinely publishes these reports on its web site without editorial or peer review. For more information about the projects program at WPI, see

<http://www.wpi.edu/Academics/Projects>

Abstract

Nature contributes to the wellbeing of everyone, increasing self-esteem and reducing stress. Turn Back Time Farm (TBT) is an education center that offers nature-based learning and therapeutic programs for children, college students, and adults. Immersive project opportunities for college students at TBT have been limited due to a lack of overnight facilities. The purpose of this project was to design a sustainable outdoor shower to provide an amenity for overnight stays and enhance the educational and therapeutic benefits of TBT.

Acknowledgements

Our team would like to thank our sponsor, Lisa Burris, and Turn Back Time for the opportunity to help contribute to the farm's development. Burris and the staff at TBT were most helpful with providing information and meeting with us virtually on a weekly basis, especially in light of COVID-19.

We would also like to thank Professor Elisabeth Stoddard and Professor Derren Rosbach for advising us through this project. Their guidance and adaptability to the changing environment continuously steered us in the right direction.

Additionally, we would like to thank Mia Dubosarsky, the director of the STEM Education Center Professional Development at WPI, for assisting us in the possession of knowledge necessary for putting together educational material for TBT.

Finally, we would like to thank Mike Marshall, a campsite owner in Idaho, for taking time to talk about his outdoor showers with us, and we would like to thank everyone who participated in our survey. Their input was greatly appreciated.

Executive Summary

Introduction and Project Goal

Turn Back Time (TBT) is a 58-acre farm and nature education center in Paxton, MA that provides nature-based educational programs for children between the ages of 3 and 13, including a year-round outdoor preschool, afterschool programs, and summer camp. Twenty percent of all children participating in the programs at TBT are at risk youth, including those who are neuro-diverse, on the Autism spectrum, those who have experienced trauma, and those in foster care. TBT also hosts project and research opportunities for college students, including students at WPI participating in the first-year Great Problem Seminar (GPS), the junior-year Interactive Qualifying Project (IQP) and the senior-year Major Qualifying Project (MQP). Lisa Burris, the founder of TBT, is looking to expand her outreach, and the quality and quantity of programs and research opportunities for children, students, and adults by creating a residential yurt village on TBT's 58-acre property.



Turn Back Time

Figure I: Turn Back Time Logo (Turn Back Time, 2019)

Approximately 80-90% of WPI students complete their IQP project at one of WPI's approximately 50 project centers across the globe. Research shows that these immersive, hands-on, community-based projects, where students live and work within the community, provide novel and critical experiences that result in personal, professional, and academic growth (Kuo,

Barnes, & Jordan, 2019). Approximately 10-20% of WPI students are unable to go abroad for their IQP due to other responsibilities, needs, and commitments, such as ROTC, jobs, family obligations, health and personal issues, safety concerns, and more. Creating a residential yurt village at TBT will allow WPI students to engage in a high-impact immersive learning experience, while still attending to commitments and needs on campus, 15 minutes from TBT. The yurt village will also support overnight programs for at risk youth, as well as wellness retreats for families, youth, and adults. The yurt village requires facilities to accommodate overnight and long-term farm-stays. The goal of this project was to design a sustainable outdoor shower to be used by future WPI students, youth of TBT, and adults who visit the farm. The outdoor shower will also enhance the educational and therapeutic benefits of the farm.

We developed four objectives to achieve this goal: 1) Research and evaluate outdoor shower characteristics and environmental components that impact the design of an outdoor shower, 2) Understand the needs of stakeholders involved in the outdoor shower, including future users of the shower and Turn Back Time Farm, 3) Create simple preliminary outdoor shower designs that lead to the development of one final comprehensive design that fits the needs of Turn Back Time, and 4) Create an educational curriculum focused around the outdoor shower for by the TBT programs and students.

Background

Turn Back Time Farm specializes in teaching children through play and exploration in nature and on the farm. Research from across a wide range of sources and instructional approaches shows that nature-based instruction outperforms other modes of instruction (Kuo, Barnes, & Jordan, 2019). Nature promotes learning by improving learners' attention and increases interest and enjoyment in learning, while providing a calmer, safer, and more cooperative space for learning (Kuo, Barnes, & Jordan, 2019). The residential yurt village and outdoor shower will not only provide benefits for the IQP students in the form of new nature immersive facilities, but it will also provide new programs for the children at TBT, including those who are at-risk, through the use of the new village and shower.

We conducted research in the form of a background to understand the important design considerations of an outdoor shower, including greywater management, water source, building materials, and educational standards.

We first researched greywater to understand its effects on soil and how to dispose of greywater. Greywater is defined as all wastewater produced from a household that does not contain fecal matter, including water from showers, sinks, and washing machines (Elmitwalli & Otterpohl, 2011). In the background, we analyzed two options for disposing greywater: a dry well and a French drain. We also explained the advantages and disadvantages for each.

Next in our background, we researched water source options for the shower and options for heating this water. For a water source, we studied three different viable options for TBT, including water from a nearby pond, tap water, and rainwater. Owner of TBT, Lisa Burris, provided us with additional information regarding these sources, including the feasibility of using tap water and pond water. When considering heating the water source, we identified five heating options, including a solar flat plate system, direct solar heating of a container, heating from a central source, compost water heating, and a portable propane water heater.

We then studied the different materials that could be used for when the shower is built. Softwoods, hardwoods, and composites were all researched in the background, as well as options for treating the different materials. Cedar, redwood, cypress, mahogany, and white oak were all identified as potential options for the material of our outdoor shower. Additionally, we compared each material in a decision matrix based on its lifespan, cost, aesthetic, strength, maintenance, and ease of use.

In order to create an appropriate education curriculum using the STEM (Science, Technology, Engineering, and Mathematics) concepts of the shower, it was important to research the topics that students in Massachusetts learn at different grade levels. In our final section of our background, Massachusetts educational standards were researched for ages 3-13, the ages that were told TBT educates (L. Burris, personal communication, March 30, 2020). The water cycle, gravity, ecosystems, and habitats are all STEM topics that students in this age range learn about (Massachusetts Department of Elementary and Secondary Education, 2016).

Methodology

In order to accomplish our project goal and objectives, we used primary and secondary methods of data collection. Before designing an outdoor shower for TBT, we first had to research and determine the most important aspects to include in our designs. To do this, we conducted an interview with Mike Marshall, an outdoor shower owner with years of experience.

This interview provided us with his experience in designing and building outdoor showers, including the materials, water source, and water heating methods that he uses.

In order to understand TBT's need for an outdoor shower and what potential users would want in a shower, we contacted staff who work at the farm, as well as students who have experience using an outdoor shower or who might use our shower at TBT in the residential yurt village. We conducted a focus group with two TBT staff members, one of whom was a member of TBT's board of directors. We also sent out a survey to potential users of the shower, and held semi-structured interviews with our sponsor, Lisa Burris. These interviews, focus groups, and surveys, allowed us to understand key features of the shower that are critical to users and for the farm.

In addition to primary sources of research, we conducted archival research in our background into greywater management, materials, water source, and water heating methods. Decision and comparison matrices were made to evaluate the options for each of the researched topics. In order to determine if rainwater catchment was a plausible option, we also conducted an experiment that tested how much water could be collected during a typical rainstorm. A site analysis was also completed to analyze the potential locations for our outdoor shower. We visited the farm in-person during February of 2020, and again virtually in March and April. While we were at the farm, we took pictures of the potential locations and analyzed the assets of each location. Virtually, Mrs. Burris provided us with more information regarding the advantages and limitations of each location. With this information, we developed a decision matrix that determined which location would best fit the user's and sponsor's needs.

In order to create learning opportunities through the shower's STEM concepts for children ages 3-13, we studied how STEM concepts are taught to children in this age range. We then reviewed articles on early education and existing curriculums and learning modules. Additionally, from interviewing the STEM Center Professional Development Director at WPI, Mia Dubosarsky, we were able to gather valuable information on the topics children in this age range learn. From this, we chose to develop activities for children ages 8-12 because the concepts children learn at this age aligned with concepts relevant to the shower, such as the water cycle and reducing negative human impact on the earth through water reuse (Massachusetts Department of Elementary and Secondary Education, 2016).

From this research, we developed four preliminary shower designs. These designs were analyzed with a comparison matrix that allowed us to identify the important features and aspects that needed to be included in the final design. After the evaluation of these designs and receiving feedback from Lisa Burris, we completed our final outdoor shower design, incorporating all important features and aspects identified from our research.

Results and Analysis

We gathered data through a survey, focus group, interviews, site analysis, material analysis, rainwater experiment, and preliminary designs. The survey results emphasized the importance of privacy, cleanliness, and having an area for changing in our outdoor shower design. The focus group provided information about the importance of including an educational activity with the shower design, and the importance of privacy because of the schooling programs that happen nearby the shower (A. Johnston, K. Hunt, personal communication, April 8, 2020). In our interview with Mike Marshall, he explained how he uses cedar wood and propane water heaters for his outdoor showers, and that these items have been extremely beneficial due to their longevity (M. Marshall, personal communication, April 21, 2020). Mia Dubosarsky provided us with information from PBS Learning Media, Teach Engineering, and the National Science Teaching Association, and explained that we should utilize these resources to make our educational activity (M. Dubosarsky, personal communication, April 28, 2020).

Additionally, the site analysis consisted of analyzing the two locations as seen below. Location one is near the center of the farm providing little privacy, while location two is very private as it is in the middle of the woods.

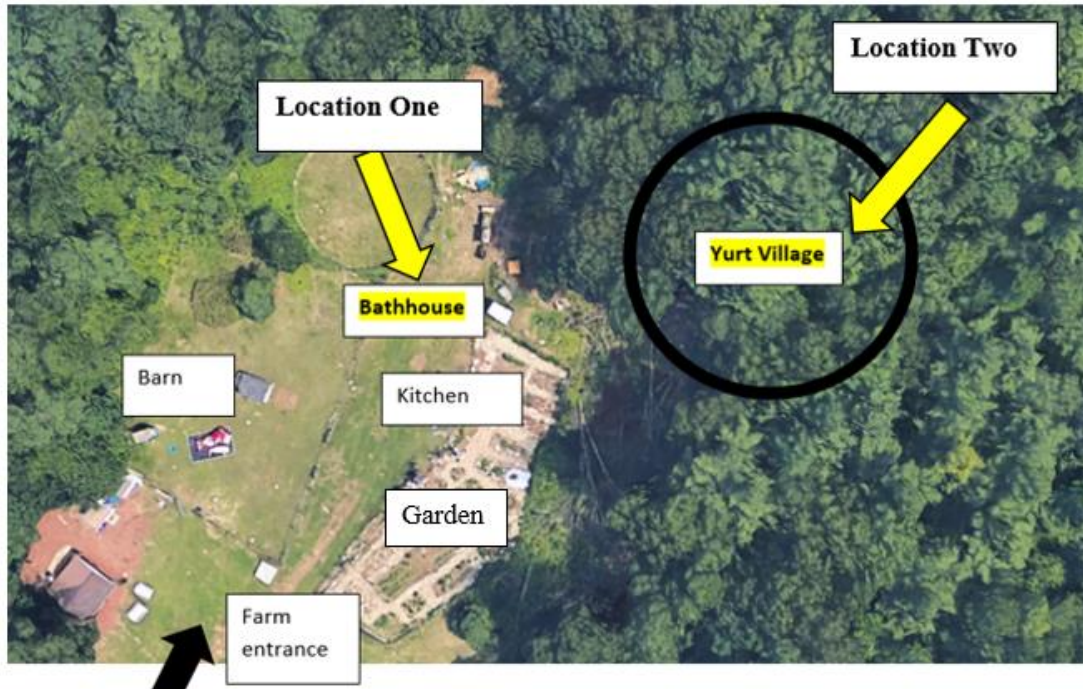

Figure II: Map of TBT for Site Analysis

We developed a comparison matrix to compare and contrast the assets and challenges of the two locations, including nature immersion, ease of water access, privacy, sunlight exposure, electricity available, and proximity to the center of the farm. The rainwater experiment and calculations provided us with the knowledge that we could only collect only 10 gallons per month, which is not even enough for one shower as a typical shower requires 17.2 gallons of water (Home Water Works, 2011). A decision matrix was created to compare different types of wood that could be used for the outdoor shower. This decision matrix evaluated the different options based on cost, strength, maintenance, ease of use, and life span.

The results from the comparison matrix of the four preliminary designs showed us that it was important to prioritize privacy through wall height and to include a changing room in our final design. All of the results from this research gave us valuable information used to develop the final design of our outdoor shower.

Design Considerations

There were a number of considerations involved in designing the outdoor shower. We collected, analyzed, and applied data about potential options for the shower location, greywater

management, water supply, rainwater catchment, water heating, and materials. For the shower location, it was determined that the location in the woods of TBT, near the yurt village is the most appropriate location for TBT. This location provides maximum privacy for the user and is the location that TBT prefers (L. Burris, personal communication, April 27, 2020). When deciding on greywater management, the dry well was chosen as the more suitable option for the outdoor shower. A dry well filters harmful materials more effectively and is less expensive than a French drain (John Riha, 2011; Wurochekke et al., 2016). The shower should be using tap water as the main water source, with an optional rainwater catchment system. After evaluating the water source options, tap water was the only option that provided a constant supply of clean water. Additionally, Lisa Burris explained how she believed the best option would be to use tap water, but to also have the option to add rainwater as a source after the initial construction of the shower (L. Burris, personal communication, April 27, 2020). Therefore, we created a rainwater catchment system that can be easily added to shower at a later date. Our survey respondents indicated that having hot water at the shower was important. After evaluating a variety of options for water heating, we chose to include a propane water heater, as it is easily incorporated, requires no electricity, and is easy to take care of (M. Marshall, personal communication, April 21, 2020). Finally, based on our materials decision matrix and our preliminary designs, we identified cedar as the more effective shower material. Cedar is proven to be rot and insect resistant and has a lifespan of up to 10 years (Urbanline Architectural, 2018). All of these elements are incorporated into our final design and instructions that were given to Turn Back Time.

Final Design

Our final outdoor shower design is 5 feet wide and 8 feet long. We decided to make it 5 feet wide because results from our survey expressed the need to have plenty of space inside the shower. It would give the shower user enough space to comfortably shower while not feeling too exposed. We made it 8 feet long so there was enough room to have 2 separate areas, a dry changing area, and a shower area, which was key to our survey takers and participants. The two sections of the shower are separated by a shower curtain that keeps the changing area dry while users are showering. To make the user of the shower feel private while using the shower, we made the walls 7 feet tall and have them flush with the ground. The tall walls also make the

shower more private for the user, an important consideration identified through our focus group and survey. The shower also has optional features, as requested by the sponsor, including a rainwater collection system and lattice structure that can be added to the shower after the construction, if desired. The changing area has a bench, hooks, cedar wood floors, and secure and dry spaces to put your clothes and belongings when showering. Our research and analysis show cedar to be the best material to build the shower because it is less expensive than other options - naturally insect, weather, and rot resistant. In addition, cedar only requires maintenance every 5-10 years, compared to other options that need yearly maintenance (Edwards, 2012).

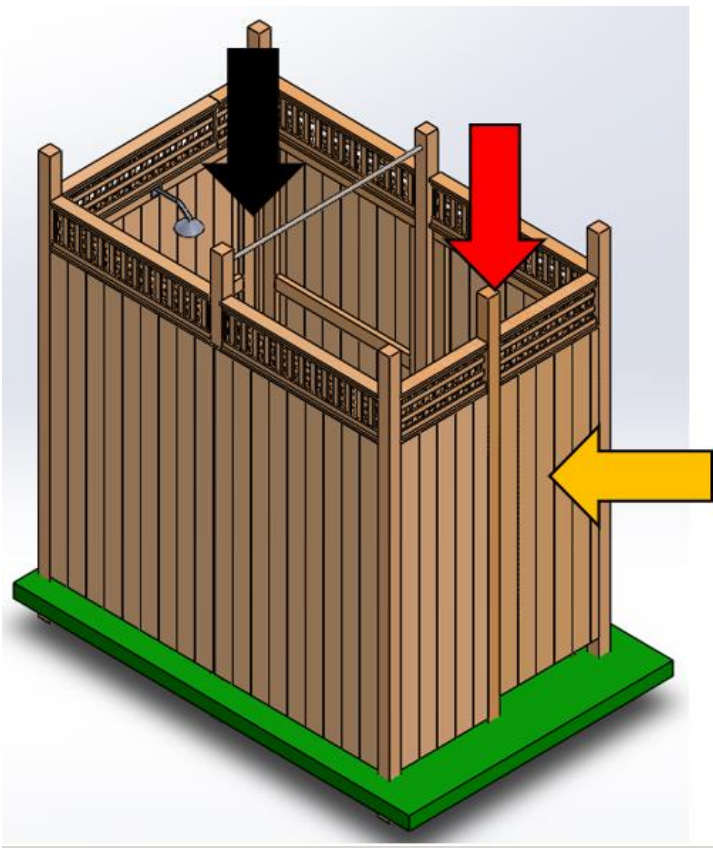

Figure III: Final Shower Design

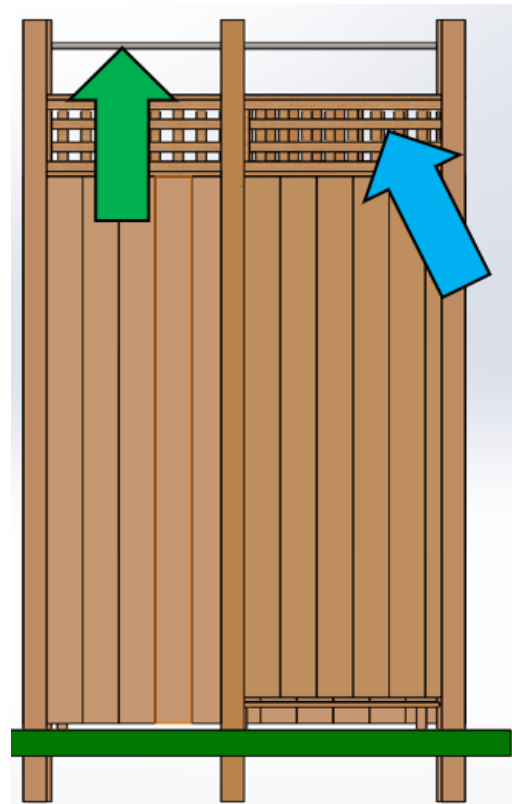

Figure IV: Final Shower Design

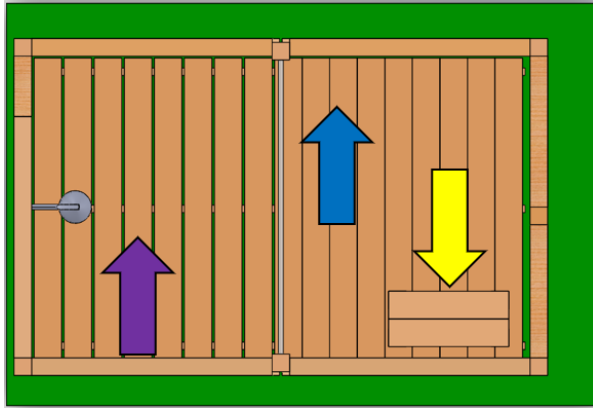

Figure V: Final Shower Design

Colors	Corresponding
Black	Shower Area
Red	Changing Area
Yellow	Door
Purple	Separated floorboards in the showering area
Blue	Flush floorboards in changing area
Cyan	Lattice structure
Green	Shower curtain rod
Yellow	Bench

Table I: Outdoor Shower Features

With the final design, we created instructions and blueprints for the build of the shower, as we were unable to build the shower given the circumstances with COVID-19. All together we are confident that we designed a sustainable outdoor shower, that fits the needs of TBT, and WPI students.

The purpose of this project was to support TBT’s development of a residential yurt village by designing an outdoor shower, a key amenity, and an additional resource to enhance TBT’s educational and therapeutic offerings. The shower and the yurt village will allow underserved WPI students, who may not have been able to live and work at a residential project center, to have a full, immersive project experience. The shower will also provide educational and therapeutic benefits for at-risk children and families in overnight programs, as well as adults through wellness retreats. Having the outdoor shower is an appealing aspect that will draw in more people to the farm’s community, to experience and realize the beauty of nature.

Authorship

Section Title	Primary Author	Primary Editor
Abstract	Dalila	Collaboration
Acknowledgements	Dalila	Collaboration
Executive Summary	Collaboration	Collaboration
1. Introduction	Collaboration	Collaboration
2. Background (Intro)	Aaron	Collaboration
2.1 Greywater Management	Aaron	Zach
2.1.1 Greywater Treatment	Aaron	Zach
2.2 Water Source	Zach	Collaboration
2.2.1 Tap Water	Zach	Dalila
2.2.2 Rainwater	Zach	Aaron
2.2.3 Beaver Pond Water	Aaron	Andy
2.3 Water Heating	Zach	Collaboration
2.3.1 Solar Flat Plate	Zach	Andy
2.3.2 Direct Solar Heating (Container)	Zach	Dalila
2.3.3 Water From Central Heating	Aaron	Andy
2.3.4 Compost Water Heating	Dalila	Zach
2.3.5 Portable Propane Water Heater	Zach	Aaron
2.4 Outdoor Shower Aesthetics and Privacy	Dalila	Aaron
2.4.1 Aesthetics	Dalila	Aaron
2.4.2 Privacy	Dalila	Aaron
2.5 Building Materials	Andy	Zach
2.5.1 Rot-Resistant Softwood	Andy	Zach
2.5.2 Hardwoods	Andy	Zach
2.5.3 Composites	Andy	Aaron

2.6 Wood Preservatives	Andy	Zach
2.6.1 Pressure Treated	Andy	Aaron
2.6.2 Non-Toxic Oils	Andy	Aaron
2.6.3 Eco Wood Treatment	Andy	Aaron
2.6.4 Shou Sugi Ban	Andy	Aaron
2.7 Educational Standards for STEM	Dalila	Aaron
2.8 TBT Mission, Programs...	Aaron	Zach
2.8.1 TBT Current Facilities and Needs	Aaron	Dalila
3.0 Methodology (Intro)	Aaron	Collaboration
3.1 Objective 1	Collaboration	Collaboration
3.2 Objective 2	Collaboration	Collaboration
3.3 Objective 3	Collaboration	Collaboration
3.4 Objective 4	Collaboration	Collaboration
4.0 Results and Analysis (Intro)	Aaron	Collaboration
4.1 Survey	Aaron	Andy
4.2 TBT Focus Group	Aaron	Zach
4.3 Interviews	Aaron	Dalila
4.3.1 Mike Marshall	Zach	Aaron
4.3.2 Mia Dubosarsky	Dalila	Aaron
4.4 Rainwater Experiment	Aaron	Aaron
4.5 Material Analysis	Andy	Aaron
4.6 Site Analysis	Aaron	Zach
4.7 Preliminary Designs	Collaboration	Collaboration
5.0 Design Considerations (Intro)	Aaron	Collaboration
5.1 Shower Location	Aaron	Zach
5.2 Greywater Management	Aaron	Zach

5.3 Water Supply	Zach	Collaboration
5.4 Rainwater Catchment System	Aaron	Zach
5.5 Water Heating Method	Zach	Aaron
5.6 Materials	Andy	Dalila
6.0 Shower Design (Intro)	Aaron	Collaboration
6.1 Instructions for the Design	Aaron	Collaboration
7.0 Educational Components (Intro)	Dalila	Collaboration
7.1 Water Filtration	Dalila	Aaron
7.2 Water cycle in a bag	Dalila	Zach
8.0 Recommendations (Intro)	Zach	Aaron
8.1 Blueprints and Construction	Zach	Aaron
8.2 Maintenance	Aaron	Zach
8.3 Suggested Parts	Zach	Collaboration
8.3.1 Propane Heater	Zach	Aaron
8.3.2 Drainage Rock	Zach	Aaron
8.3.3 Miscellaneous	Zach	Aaron
9.0 Conclusion	Collaboration	Collaboration

Table of Contents

Abstract	ii
Acknowledgements	iii
Executive Summary	iv
Introduction and Project Goal	iv
Background	v
Methodology	vi
Results and Analysis	viii
Design Considerations	ix
Final Design	x
Authorship	xiii
Table of Contents	xvi
List of Figures	xix
List of Tables	xx
List of Acronyms	xxi
1.0: Introduction	1
2.0: Background	3
2.1: Greywater Management	4
2.1.1: Greywater Treatment	4
2.2 Water Source	8
2.2.1 Tap Water	8
2.2.2 Rainwater	8
2.2.3 Beaver Pond Water	8
2.3: Water Heating	9
2.3.1: Solar Flat Plate System	9
2.3.2: Direct Solar Heating Through Use of a Container	10
2.3.3: Water From a Central Heating System	11
2.3.4: Compost Water Heating	11
2.3.5 Portable Propane Water Heater	12
2.4: Outdoor Shower Aesthetics and Privacy	13
2.4.1: Aesthetics	13
2.4.2: Privacy	14
2.5: Building Materials	14
2.5.1: Rot-Resistant Softwood	15
	xvi

2.5.2: Hardwoods	15
2.5.3: Composites	15
2.6: Wood Preservatives	16
2.6.1: Pressure-Treatment	16
2.6.2: Non-Toxic Oils	17
2.6.3: Eco Wood Treatment	17
2.6.4: Shou Sugi Ban	18
2.7: Educational Standards for Science, Technology and Engineering	19
2.8: Turn Back Time Farm Mission, Programs, and Current Challenges	20
2.8.1: Turn Back Time Current Facilities and Needs	21
3.0: Methodology	23
3.1: Research and evaluate outdoor shower characteristics and environmental components that impact the design of outdoor showers.	23
3.2: Understand the needs of stakeholders involved in the outdoor shower, including future shower users and Turn Back Time Farm.	24
3.3: Create simple preliminary designs that lead to the development of one final comprehensive design that fits the needs of Turn Back Time	25
3.4: Create an educational curriculum focused around the outdoor shower for use by the TBT programs and children.	26
4.0: Results and Analysis	28
4.1: Survey	28
4.2: Turn Back Time Focus Group	30
4.3: Interviews	31
4.3.1: Mike Marshall	32
4.3.2: Mia Dubosarsky	33
4.4 Rainwater Experiment	33
4.5 Material Analysis	34
4.6 Site Analysis	36
4.7 Preliminary Designs	38
5.0: Design Considerations	42
5.1: Shower Location	42
5.2: Greywater Management	43
5.3: Water Supply	45
5.4 Rainwater Catchment System	46
5.5: Water Heating Method	47

5.6: Materials	49
6.0 Final Shower Design	50
6.1: Instructions for the Design	53
7.0: Educational Components	55
7.1: Water Filtration Experiment	55
7.2: Water Cycle in a Bag	58
8.0: Recommendations	60
8.1: Blueprints and Construction	60
8.2: Maintenance	60
8.3: Suggested Parts	61
8.3.1: Propane Heater	61
8.3.2: Drainage rock	62
8.3.3: Miscellaneous	62
9.0 Conclusion	63
References	64
Appendix A: Turn Back Time Interview Questions	70
Appendix B: Survey Questions for Potential Shower Users	71
Appendix C: Materials List	72
Appendix D: Instructions for Building the Shower Structure	73
Appendix E: Lattice Structure Instructions	100
Appendix F: Rainwater Catchment Build Instructions	102
Appendix G: Suggested parts links	104

List of Figures

- Figure I: Turn Back Time Logo
- Figure II: Map of TBT for Site Analysis
- Figure III: Final Shower Design
- Figure IV: Final Shower Design
- Figure V: Final Shower Design
- Figure 1: Outdoor Shower Example
- Figure 2: French Drain
- Figure 3: Diagram of a Dry Well
- Figure 4: Solar Panel System Diagram
- Figure 5: Portable Propane Water Heater
- Figure 6: Composite Wood
- Figure 7: Eco Wood Treatment
- Figure 8: Shou Sugi Ban
- Figure 9: STE Triangle
- Figure 10: How Long Do You Shower Pie Chart
- Figure 11: Important Aspects of a Shower Bar Graph
- Figure 12: Survey Response Word Cloud
- Figure 13: Mike Marshall's Outdoor Shower
- Figure 14: Farm Layout
- Figure 15: Zach's shower Design
- Figure 16: Aaron's shower Design
- Figure 17: Andy's Design
- Figure 18: Dalila's Design
- Figure 19: Shower Location
- Figure 20: Dry Well System
- Figure 21 and 22: Dry Well Dimensions
- Figure 23: Water catchment system
- Figure 24: Shower Isometric View
- Figure 25: Shower Top View
- Figure 26: Shower Front View
- Figure 27: Water Filtration Activity Diagram
- Figure 28: Water Cycle in a Bag
- Figure 29: Propane heater
- Figure 30: Drainage rock

List of Tables

- Table I: Outdoor Shower Features
- Table 1: Features of an Outdoor Shower
- Table 2: French Drain Features
- Table 3: Water Collection in Paxton, MA
- Table 4: Savings per Month
- Table 5: Materials Decision Matrix
- Table 6: Location Comparison Matrix
- Table 7: Shower Design Matrix
- Table 8: Rainwater Collection System
- Table 9: Water Heating Comparison Matrix
- Table 10: Final Shower Design
- Table 11: Overall Budget

List of Acronyms

Turn Back Time	TBT
Major Qualifying Project	MQP
Interactive Qualifying Project	IQP
Great Problem Seminars	GPS
Reserve Officer Training Corps	ROTC
Sodium Absorption Rate	SAR
Science Technology/Engineering	STE
Science Technology Engineering and Mathematics	STEM
United States Department of Agriculture	USDA
Chromated Copper Arsenate	CCA
Alkaline Copper	AC
Quaternary Ammonium Compounds	QAC

1.0: Introduction

In 2019, Turn Back Time Farm, a local 58-acre farm in Paxton, MA, hosted over 600 children who spent a total of 26,000 hours in nature (Turn Back Time, 2019). Turn Back Time (TBT) specializes in teaching children through play and exploration in nature and on the farm. Roughly 20% of these children are at-risk youth, including those who are neurodiverse, on the Autism spectrum, have experienced trauma, and those in foster care. They offer year-round preschool, afterschool programs, mini-camps during school breaks, and a summer camp. Turn Back Time also works to provide novel research and project opportunities for WPI's Interactive Qualifying Project (IQP) students who want or need to stay closer to campus.

A Farm Stay Project Center at the farm's yurt village will open in March of 2021, providing these students with the opportunity to have the same fully immersive experience as other WPI students for their IQP. Students participating in research projects on the farm, as well as youth summer camps will be able to stay overnight in order to fully immerse themselves in the project and the community. As such, TBT was seeking to expand their overnight facilities to include an outdoor shower. The aim was for these facilities to be sustainable, climate resilient, and attractive for people coming to the farm; with the addition of new learning opportunities for the children who benefit from the farm.

The goal of our IQP was to design a sustainable outdoor shower for Turn Back Time Farm to be used by future WPI students, youth of TBT, and adults who visit the farm. In order to achieve this goal, we developed the following objectives: first, to research and evaluate outdoor shower characteristics and environmental components that impact the design of an outdoor shower. Second, we aimed to understand the needs of stakeholders involved in the outdoor shower, including future shower users and TBT. Our third objective was to create simple preliminary outdoor shower designs that lead to the development of one final comprehensive design that fits the needs of TBT. Our fourth and final objective was to create an educational curriculum focused around the shower's STEM concepts for use by the children in TBT's programs. In this report, you will first find our background, with a review and an analysis of relevant literature and journal articles. Next, you will find a description of the methods we used for our research, including semi-structured interviews, focus groups and surveys. Finally,

we present the results and findings of our research, as well as our recommendations and the final design and building instructions that we provided to our sponsor, Turn Back Time Farm.

2.0: Background

In this section, we discuss the different technological, environmental, and architectural aspects of outdoor showers. This chapter also discusses Turn Back Time Farm, our sponsor, in detail, including their mission, goals, and objectives in relation to the outdoor shower. This provides the knowledge and information to develop appropriate methods that will be used to achieve our project goal.

Outdoor showers are showers placed in an outdoor environment that are used for a variety of reasons. Becoming much more popular in recent years, homeowners, businesses, farms, and beaches, are beginning to install outdoor showers for various purposes, including simply rinsing off, to connect with nature, and to add an attractive aesthetic to a property (Home Design Lover, 2015). Below is an example of an outdoor shower with arrows indicating key features that will be explored in this background.

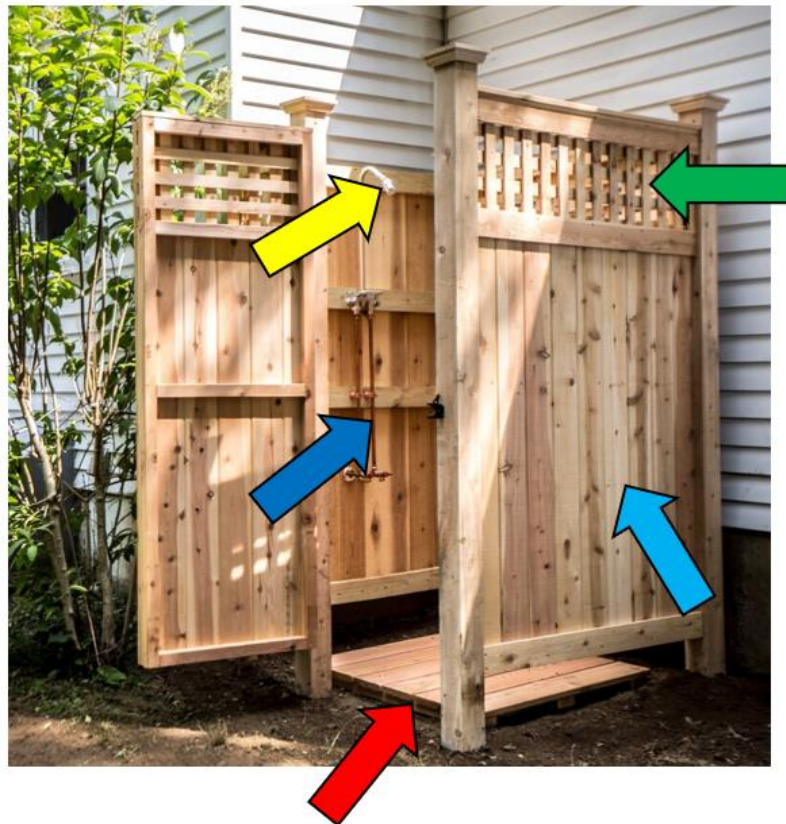

Figure 1: Outdoor Shower Example
(Cape Cod Shower Kits Co.,)

The arrows above are color-coded to the feature that they are indicating. These features are all researched below.

Color	Feature
Red	Shower Greywater Disposal
Blue	Piping Materials
Yellow	Water Source
Green	Wall height for privacy
Light Blue	Materials for Construction

Table 1: Features of an Outdoor Shower

2.1: Greywater Management

When constructing an outdoor shower, it is important to consider all potential impacts that it may have on the surrounding environment, and how to minimize any negative effects. Greywater is defined as all wastewater produced from a household, including water from showers, sinks, and washing machines, however it excludes toilet water, as toilet water has come in contact with fecal matter (Elmitwalli & Otterpohl, 2011). For the outdoor shower, we researched the best suited methods for managing the greywater for our outdoor shower.

2.1.1: Greywater Treatment

The Sodium Adsorption Ratio (SAR) is a standard method of measuring the quality of greywater. It is a measure of the amount of sodium relative to the amount of calcium and magnesium in a sample of water that has been extracted from soil. The USDA states that any soil with a SAR higher than 13 has been degraded (USDA n.d.). This makes it imperative to properly dispose of any wastewater or greywater properly so that it does not ruin the surrounding soil by adding excess amounts of calcium and magnesium that make the soil unhealthy for farming and organisms that live in the ground (USDA n.d.). Most shower wastewater results in

the soil having a SAR of about 1 after being filtered through natural materials, meaning that it will not be detrimental to soil (Travis, Wiel-Shafran, Weisbrod, Adar, & Gross, 2010).

In regards to a shower at TBT, it was important to determine practices for greywater treatment in order for the soil to have the appropriate SAR. For TBT, a greywater filtration system must be cost efficient and easy to maintain, while leaving the soil in good condition. This section will explore techniques that meet these requirements.

One technique of treating the greywater is through a French drain. A French drain consists of a trench dug on a downhill slope that a special pipe is placed into. Figure 2 demonstrates how a French drain works. When the shower drains, the greywater water flows through the black slotted pipe that has holes every 5 inches along the bottom. When flowing through the pipe, water would fall through these holes and then be filtered through the white Styrofoam that surrounds the black pipe. After that, the water reaches the surrounding soil.

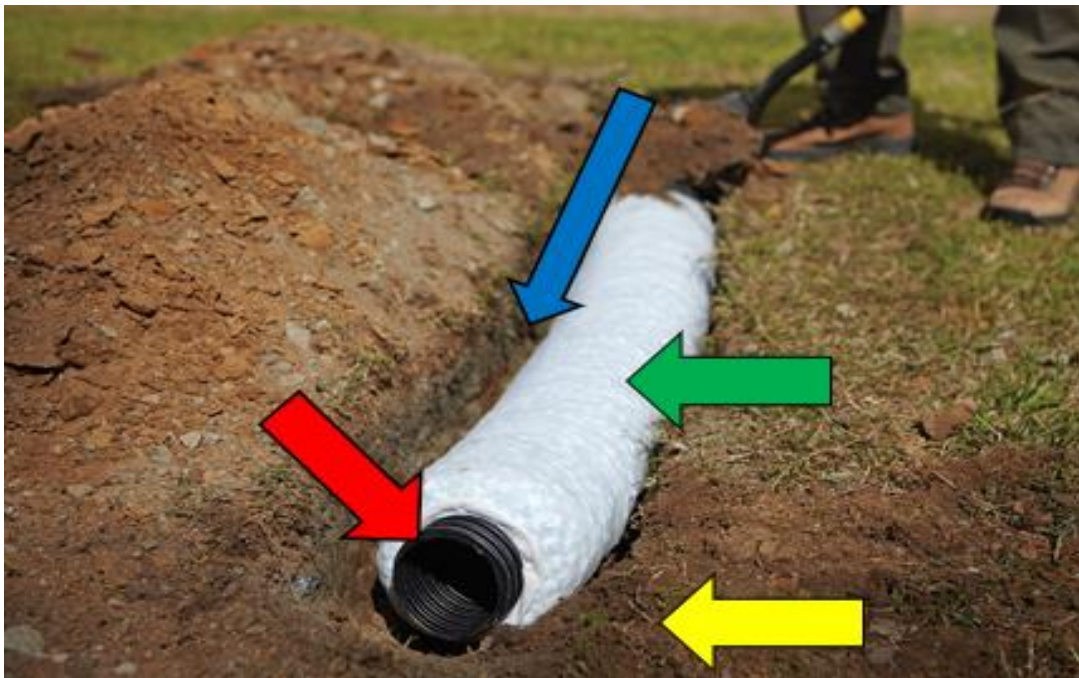

Figure 2: French Drain (How to install a french drain.n.d.).

Color	Indication
Red	Perforated pipe with holes every five inches on the bottom
Green	Absorption material wrapped around the perforated pipe
Yellow	Surrounding Soil
Blue	Water flow in the pipe

Table 2: French Drain Features

The water in a French drain relies on gravity to keep it moving. Because of this, a French drain requires one inch of slope for every eight feet of pipe in order for the wastewater to constantly flow through the pipe. (Outdoor Shower Company, 2020). This technique effectively drains the water throughout a large area preventing any soil from becoming too moist because the water is drained into the ground every five inches (How to install a French Drain n.d.). However, because the water is filtered through Styrofoam, the French drain is not sustainable. Styrofoam is made from polystyrene, a chemical that is harmful to the environment and when buried underground, as it is in a French drain, small animals and insects can mistake the Styrofoam for food, which ultimately can kill them (Nukmal, Umar, Kanedi, & Amanda, 2017). Additionally, when soil is exposed to polystyrene for long periods of time, it can absorb the chemical making the soil dangerous for irrigation uses (Schlemmer, Sales, & Resck, 2009).

Another way of treating the greywater is by using a dry well. Unlike the above technique where the water was drained away from the location of the shower, this technique disposes the water directly below the shower. A dry well is best used in locations where the ground and soil are wet (Aqua-Bright Irrigation and Illumination, 2018). Dry wells consist of digging a hole about 16 inches beyond the perimeter of the shower and at least three feet deep into the ground. The hole is then backfilled with natural materials, such as stones, drainage rock, septic sand, and charcoal. These materials capture any harmful chemicals in the water before they can permeate the surrounding soil. This technique also allows for the water to be dispersed along the entirety of the hole and evenly throughout the soil (Bob Vila, 2016).

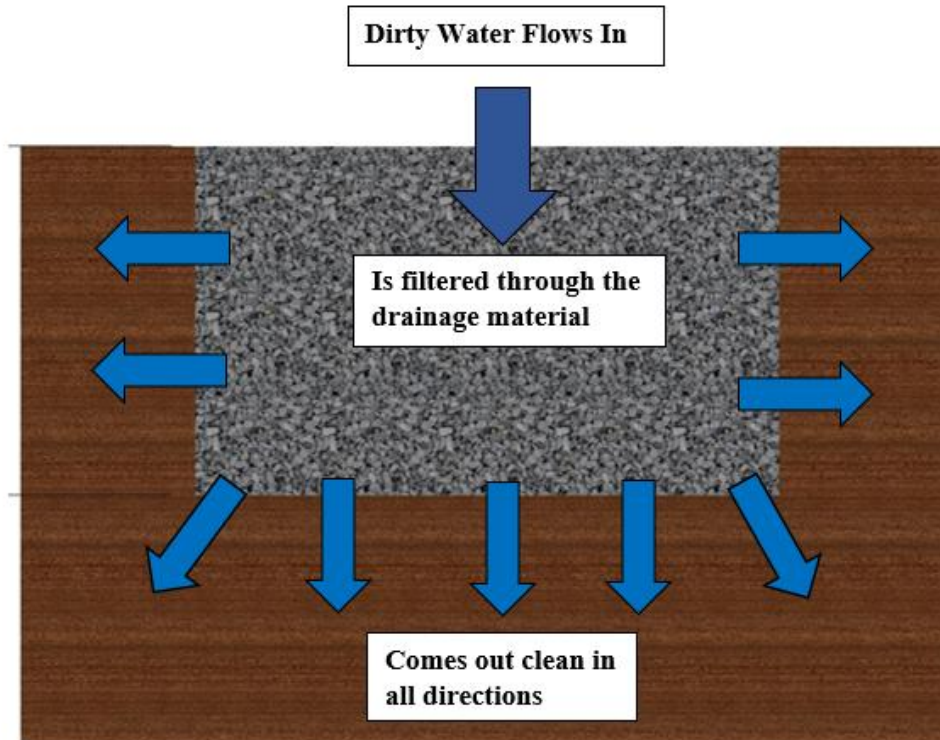

Figure 3: Diagram of a Dry Well

Unlike the French drain, the dry well is an environmentally sustainable option because it relies entirely on natural materials for the filtration of the greywater. A 2016 study demonstrated that the natural materials used in this filtration technique remove large amounts of total phosphorus and total nitrogen, two harmful pollutants in greywater, by almost 96%, bringing the SAR of the soil to 1 after the water has soaked into the soil (Wurochekke et al., 2016). Additional natural materials that can be added to a dry well that remove total phosphorus and total nitrogen amounts in greywater include pine bark and activated charcoal, removing total phosphorus by 97% (Dalahmeh et al., 2012). The dry well requires no maintenance after being built and can be very inexpensive for smaller dry well applications. The average cost of a dry well is \$2,559; however, this is for commercial applications that are disposing water for entire buildings (CraftJack, 2018). For small applications, such as an outdoor shower, the cost of a dry well is less than \$100, excluding any labor costs, because they are typically smaller and require less material (CraftJack, 2018). Compared to a French drain, which can cost between \$200 and \$1250, the dry well is a much cheaper option (John Riha, 2011).

2.2 Water Source

One of the main design considerations when designing an outdoor shower is how the shower will be supplied with clean water for people to bathe in. Below we break down the variety of water sources that were considered when designing an outdoor shower at Turn Back Time Farm.

2.2.1 Tap Water

Tap water is the easiest water source available for the outdoor shower at TBT. With the addition of the new bathhouse, Lisa Burris informed us that running hoses or pipes from the bathhouse to the outdoor shower would be a viable option (L. Burris, personal communication, March 30, 2020). This water source would provide the shower with a constant supply of clean fresh water.

2.2.2 Rainwater

Rainwater is a renewable clean water source option for the outdoor shower at TBT. A 2010 study demonstrated that rainwater is suitable for household application use, including showering, washing machines, and dishwashers, without having to be treated or filtered (Li, Boyle, & Reynolds, 2010). In order to use rainwater, a rainwater catchment system must be installed to maximize the amount of water collected. Such systems include a catchment area and a tank for storage. Most systems utilize the roof of a building as the catchment area, as the size of the catchment area directly correlates to the amount of water that can be collected (Plum Creek Conservation District, 2006). The larger the catchment area, the more rainwater that can be collected. This poses a problem for collecting rainwater at an outdoor shower, as they typically do not have roofs and if they do, then the size of the roof is relatively small, resulting in little total water collection. Additionally, rainwater is not a constant water source and the farm could potentially go weeks without water, leaving the shower without a water source.

2.2.3 Beaver Pond Water

TBT farm has a beaver pond on their property that could be used as a water source for the outdoor shower. Using the pond water would require pumping the water up to the shower location, increasing the cost of the shower roughly 300 dollars for a water pump and plumbing

(Lowe's Home Improvement, 2020). Lisa Burris informed us of some concerns that she has regarding using pond water as well. She explained that in past years, the pond has dried out and that she would not want to encourage this by using the water for a shower. She also explained that users may not find the shower appealing if the water source is from the pond, as many different animals live in the pond (L. Burris, personal communication, March 30, 2020).

2.3: Water Heating

Sustainability is one of Turn Back Time's most important considerations with the outdoor shower project. Due to this, we discussed alternative water heating methods, as well as traditional heating from a central heating system. All of the alternative heating options have advantages and disadvantages, and it was important to assess these options with regards to TBT's needs. In this section, we examined the different ways to heat the water that may be useful for the outdoor shower.

2.3.1: Solar Flat Plate System

An outdoor shower will mostly likely be used more often in the months of summer. With these hot days, there is an abundance of sunlight, providing an opportunity to take advantage of the energy from the sun. The sun gives off about 1,360 Watts of energy per square meter (Lindsey, 2009).

Solar water heating is the use of a collecting plate that captures the sun's energy and converts it to heat that is used to heat the water collected in a storage tank (Esen & Esen, 2005).

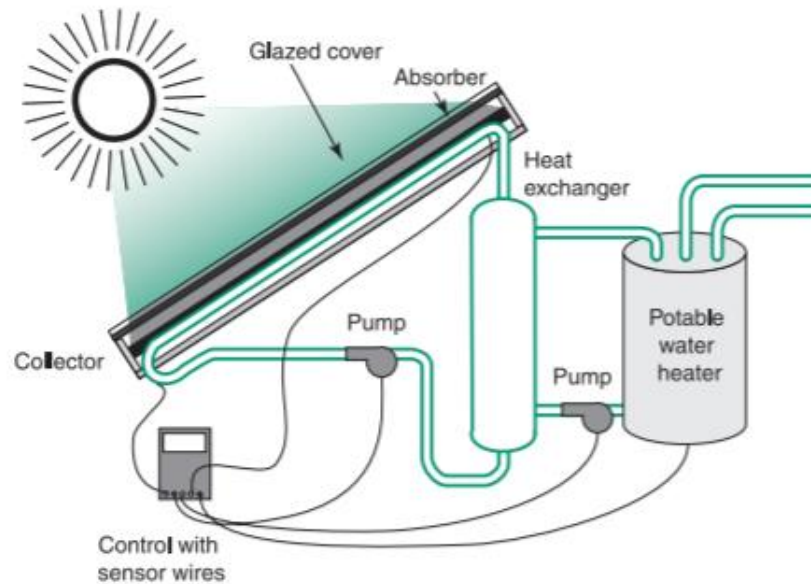

Basic components of a flat plate collector system

Figure 4: Solar Flat Plate System Diagram

(Southface Energy Institute, 2004)

Solar energy is sustainable and renewable because it is a constant natural resource supplied to the earth on a daily basis. The solar plate system takes advantage of this abundant resource, making the method very eco-friendly, unlike other methods, such as natural gas or coal heating that must be mined from the earth, causing them to be extremely unsustainable. It is important to note that systems like the one pictured above have a high upfront cost; at least \$600 for a small system (Northern Lights Solar Heating, n.d.). Additionally, these systems are inefficient during times of low sunlight and inclement weather (Esen & Esen, 2005). Disadvantages like these must be considered when reviewing solar energy options.

2.3.2: Direct Solar Heating Through Use of a Container

Similar to solar power, using direct sunlight to heat a large container of captured rainwater is another potential method to consider for the outdoor shower. This option is inexpensive, estimated to cost around \$100-\$150 including all the necessary components such as a 55 gallon container, hoses for plumbing, and a filter (Lowe's Home Improvement, 2020). Using the sun to heat a bucket of water is similar to solar because it takes advantage of the sun's energy. This energy can be captured through a water catchment system that would be in direct

sunlight throughout the day. The captured rainwater water is heated by the sun's rays and sent through a filter system when needed for the shower, ensuring the water is safe to use. Some of the disadvantages include temperature differences due to variable weather conditions, as well as shortage of rainwater supply. Cold, cloudy days and droughts could potentially lead to a lack of usable water for the shower; therefore, this option would need a backup water supply to ensure there is always water accessible.

2.3.3: Water From a Central Heating System

When available, tap water is the easiest and most reliable option when constructing an outdoor shower. There is a new building being built at TBT that will have two bath houses as well as a fully functional kitchen. This building will have running water and it would be easy to install a tap that could reach the shower outside. The easiest way to get both hot water and cold water to the shower is to install a hot-water faucet next to an existing cold water garden faucet or cold water tap (Hall, 2018). Stainless steel hoses are ideal in this situation, because of their durability and ability to detach and store during the winters.

However, heating tap water on site of the shower, would not be as sustainable as other options, making it less appealing to the people of TBT. The tap water is heated by means of natural gas or electricity, both of which produce pollutants of some form, making them unsustainable. For example, propane is a relatively clean burning fuel, but it still produces waste such as particulate matter, sulfur dioxide, nitrogen oxides, nitrous oxide, carbon monoxide, and greenhouse gases (Smith, 2020). Increases in greenhouse gases can lead to heat trapping, raising the temperature of the Earth. This can lead to climate change, rising sea levels, and flooding (Department of Communication, Climate action and Environment, 2020). Nevertheless, if we were to use tap water as a backup to one of the other options, we could still have a sustainable option as the primary source for the shower, such as the other options laid out above. The shower could be designed so that it only uses the tap water once the rainwater tank is drained completely.

2.3.4: Compost Water Heating

In the case that sunlight is not available for heating water, a compost water heater would be an efficient alternative. This system of heating can be as simple as winding a pipe through a

pile of compost (Roberts, 2017). Composting, the process of decomposition in organic matter, goes through three main stages. The first two stages are where the most heat is developed. During the first stage, mesophilic microorganisms can raise the temperature to over 104 degrees Fahrenheit. In the second stage, thermophilic microorganisms can raise the temperature even higher to over 130 degrees (Ross, 2018). If a pipe coming from a water source is coiled through this heated pile, then the water flowing through the pipe would heat up as well, thus providing a warm water source. In addition, the resulting compost, once decomposed, can be used as fertile soil for crops and plants.

Though composting is a good way to heat up water while also decomposing waste, it does have its disadvantages. One of these disadvantages is that compost takes a lot of time and effort to maintain. There needs to be a carbon-rich compost to nitrogen-rich compost ratio of around 30:1 in order for the natural composting process to be most effective (Ross, 2018). In the case of acting as a heating source, the ratio may need to differ so that the pile would be able to last for a longer period of time. For example, the carbon-rich compost would need to be decreased or the nutrient-rich compost increased for a more balanced system. In addition, the compost pile would need to remain moist and be flipped occasionally to prevent overheating (Jonathon Engels, 2017). Another disadvantage, in terms of appeal, is that it may be an unpleasant view. Depending on the organic materials used, the pungent smell could also pose as a problem.

2.3.5 Portable Propane Water Heater

Portable propane water heaters are small units of heating that are often used when space is limited. They are often used on recreational vehicles but would serve well with our outdoor shower. (Houseweather, 2020). They are small in size and lightweight, allowing for it to be hung up on the side of the shower. Portable water heaters are attached to a water source and then as the water flows through it, the burner heats the water (Plumbing Lab, 2020). Portable water heaters are tankless, so they are very easy to manage and are more appealing than tank systems. This method of heating is also the quickest with being able to heat up cold water up to 100°F in less than 5 seconds. Adding an additional 10 seconds to pull the water from the source to the water heater and usable warm water is available in under 20 seconds (Plumbing Lab, 2020).



Figure 5: Portable Propane Water Heater

2.4: Outdoor Shower Aesthetics and Privacy

Architecture and design, as in all aspects of life, are closely connected with human emotion (Jaffe, 2013). Therefore, it was important to create a space that feels comfortable and safe for those that will use it. In this section, we discussed ways we can make the shower both visually appealing and private for the individual users.

2.4.1: Aesthetics

First and foremost, it is important that users enjoy using the shower. To help ensure this, the shower had to be aesthetically pleasing. Aesthetic appeal is related to our discernment of beauty. It pertains to all five of our senses of touch, sight, hearing, smell, and taste (Jodie, 2019). The significance of aesthetics is how it affects our emotions. The term “aesthetic emotion” refers to our psychological response to beauty (Exploring your mind, 2019). Though these emotions can either be good or bad, there are some designs that widely arouse positive feelings.

For designing an outdoor shower, our main focus pertained to visual appeal. For instance, different shapes produce different emotions in people. Circular and curved designs are easily appealing to us because they resemble the patterns of nature, giving people a sense of relaxation and control in their environment (Lima, 2017). These designs elicit feelings of peacefulness and

safety, as opposed to more angular designs that trigger fear because of their sharpness (Jaffe, 2013).

2.4.2: Privacy

Considering the privacy of users was another necessary step in designing an outdoor shower (Beiles, 2008). Privacy can be achieved through many means. In fact, privacy can be distributed into four individual levels: acoustical, visual, territorial, and informational (Steelcase Research, 2016). The two most relevant forms of privacy for this project were acoustical and visual. Acoustical privacy has to do with the amount of noise present in an environment. It is determined by how disturbing outside noise is as well as the volume of noise a person can create without worrying about disturbing others. For an outdoor shower, the walls will not be insulated, so there is less of a barrier for noise (Contract Environments, 2014). However, because it is outside, there should not be a lot of concern for disturbing others because the noise present in the environment could act as ambience and it would feel more natural.

Visual privacy is the confidence that a person will not be seen by anyone (Steelcase Research, 2016). It is especially important for an outdoor shower because of the vulnerable state that users will be in. To mitigate this possibility, the use of a door and lock at the entrance will help. We also considered whether or not it will be appropriate to have the shower open to the sky or use some sort of roof to provide additional privacy. In addition, we considered making the walls high enough to conceal the user, and to prevent others from looking inside. This allows the user to experience the ambience of the outside without feeling vulnerable.

2.5: Building Materials

One of the most important aspects of building an outdoor shower was considering the materials it will be made out of. Since the shower is outdoors there are weather and environmental effects that need to be taken into consideration, such as rain, snow, and humidity, so the structure does not rot or collapse. Additionally, most shower designers/owners want the shower to fit aesthetically into the environment it will be placed in. This makes it necessary to use natural materials, like wood and stone, to build the shower. In this section we looked at different materials that could potentially be used to build an outdoor shower, the advantages and disadvantages of these materials, and the different types of treatment.

2.5.1: Rot-Resistant Softwood

Rot-Resistant softwood is natural and does not contain any chemicals. The wood produces natural oils and acids that make the wood weather, rot, and insect resistant (Edwards, 2012). The oils are also responsible for the pleasant aroma that comes from the wood. Examples of this type of wood are cedar, cypress, and redwood. Some of the physical advantages of untreated rot-resistant wood are that they are lightweight and inexpensive, and they also will not stretch or shrink over time (Urbanline Architectural, 2018). The major drawback of untreated rot-resistant softwood is that they are softwoods, making it not as strong as other woods. However, this would not be a major issue for a shower, but if a roof were placed over the shower it would not be able to take large loads, such as snow. Also, the wood requires maintenance, such as reapplying preservatives and stain, every couple of years to keep it from deteriorating and fading (M. Marshall, personal communication, April 21, 2020).

2.5.2: Hardwoods

Similar to untreated rot-resistant wood, hardwoods are weather, rot and insect resistant. The biggest differences between the two are that hardwoods are more difficult to work with due to their strength and are heavier. Hardwoods also tend to have a darker color and cost more. Hardwoods do not need to be maintained and can last decades without needing to be replaced (House & Home Ideas, 2016). Examples of hardwoods are oak, ipe, and mahogany.

2.5.3: Composites

Composites are a synthetic material that are made to mimic and enhance the properties of wood. Composites are as strong as wood, and are weather, rot and insect resistant, long lasting, and require little to no maintenance. Most composite woods are made of recycled plastics fibers and wood fibers (Beaulieu, 2019). They also can be made however the buyer wants them, for example, slip resistant or smooth. The biggest downside of using composites is their appearance. Composites come in many different types of colors, but it's difficult to make them look like natural wood. No matter how the composite is made or painted, it will have a plastic look and feel to it due to it being a synthetic material. Composites wood is also expensive compared to hardwoods and softwoods, about 2-3 times as much (Lowe's Home Improvement, 2020).



Figure 6: Composite Wood (DuraLife Decking, 2020)

2.6: Wood Preservatives

When wood is placed outdoors or near moisture it can become a breeding ground for bacteria and insects. This will decrease the wood's life span and cause rotting. To prevent this from happening, wood can be treated with preservatives. In this section researched different preservation options for wood.

2.6.1: Pressure-Treatment

Pressure-treating wood involves injecting the wood with a chemical preservative that protects the wood from rot (HomeAdvisor, 2016). The advantage of using wood that was pressure treated is that it is lightweight and strong, two desirable characteristics of wood, while being able to resist bacteria and insects. It also will last a long time before needing to be replaced. In a study done by the Forest Products Laboratory, it was found that pressure treated wood could be in contact with the ground for over 40 years without any sign of rot or insect infestation (Forest Products Laboratory, 2013). The major disadvantage of pressure treated wood is the chemicals that are injected into the wood. Three types of chemical treatment are: chromated copper arsenate (CCA), alkaline copper (AC), and quaternary ammonium compounds (QAC). Prolonged exposure to these chemicals can cause skin irritation, allergic reactions, eye damage, and can lead to cancer (Dahlquist, 2019). In an outdoor shower a user will not be exposed to these chemicals for long periods of time. The only thing the user would need to be cautious about is after a rainstorm. Since rain is high flowing and has a low pH, this would

increase the amount of chemicals that would leach out of the wood (S. Lebow, 1996). If a person were to take a shower after it had rained they would be in contact with a high concentration of the chemicals which can cause redness and swelling at the areas the skin was in contact with the chemicals (Delaware Health and Social Services, 2013). There is also a risk for whoever will work with the wood when building the shower. Any amount of the wood dust that is inhaled can irritate a person's lungs and throat (Delaware Health and Social Services, 2013).

2.6.2: Non-Toxic Oils

There are also non-toxic wood preservatives that increase the wood's life span without using any chemicals. These preservatives use natural materials and oils to preserve the wood. One of the most widely used non-toxic wood preservatives is linseed oil. Linseed oil is an oil that comes from flax plants. There are two non chemical forms linseed oil comes in, raw and polymerized. Raw linseed oil is the purest form of linseed oil, while polymerized linseed oil is raw linseed oil that is heated for a couple of days. The only difference this causes is polymerized linseed oil dries faster (Vermont Studios, n.d.). The advantages of using linseed oil is it is soaked easily into the wood, and protects the wood from humidity changes, and it brings out the color in the wood. The disadvantages of using linseed oil are it can take up to 10 weeks to dry, turns yellow over time, and the oil could occasionally seep out from the wood (Natural Handyman, n.d.). Another non-toxic oil that can be used to preserve wood is Tung oil. Tung oil is an oil that comes from the Tung tree. It provides the same protection as linseed oil but dries faster. It also doesn't change color over time and is highly water resistant. The negatives of using Tung oil is it has a mild odor after being applied and it takes multiple coats to fully penetrate the wood (Natural Handyman, n.d.).

2.6.3: Eco Wood Treatment

While the non-toxic oil treatments mentioned above do not contain any chemicals and are good at protecting wood from insects and rotting, they require re-application every couple of years. These oils can prolong the life of the material, but if the wood is neglected, it will rot and need to be replaced. To combat this, there are some non-toxic treatments that only require a one time application. One of these treatments is Eco Wood Treatment. Eco Wood Treatment is a powder that is composed of natural substances and minerals (Tom Faunce, 2016). When mixed

with water and applied to wood, it penetrates the wood fibers which protects the wood from water and fungal decay. It does not fade or wear over time, is easy to apply, and is inexpensive (Shahe, 2015). One disadvantage of using this product is it turns the wood a darkish grey to give it an aged look.



Figure 7: Eco Wood Treatment (Eco Wood Treatment, 2017)

2.6.4: Shou Sugi Ban

Another treatment that is non-toxic and lasts a lifetime is shou sugi ban. It is a Japanese technique where the wood is burned and sealed using an oil. This makes the wood weatherproof and rot resistant due to the moisture being removed from inside the wood and the hardening of the exterior part of the wood. This technique also helps repel insects by burning the carbohydrates that insects feed on in the wood (Shizenstyle, 2019). If the wood is burned and maintained properly it looks aesthetically pleasing and can give the wood an 80 year life span (Bolduc, 2018). The downsides to this method is that it can only be applied to certain woods and it requires a blow torch and propane tank. Also, if the wood is not burned evenly or properly it will not last as long and not look good aesthetically (Dans le Lakehouse, 2018) .



Figure 8: Shou Sugi Ban (Cady Chintis, 2015)

2.7: Educational Standards for Science, Technology and Engineering

The 2016 Massachusetts Science and Technology/Engineering (STE) Curriculum Framework provides a guideline for what children are supposed to be learning for each grade all the way up to high school (Massachusetts Department of Elementary and Secondary Education, 2016). According to that framework, the Science Technology and Engineering standards have three main components. These components, shown in the visual below, are Disciplinary Core Ideas, Science and Engineering practices, and Application.

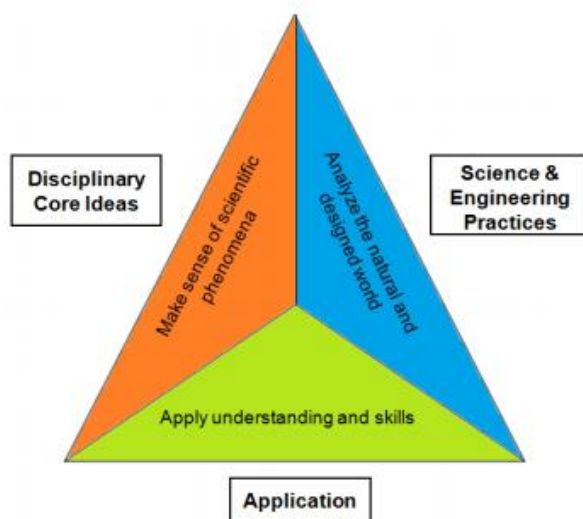

Figure 9: STE triangle

As shown in the Curriculum Framework

(Massachusetts Department of Elementary and Secondary Education, 2016)

The core ideas are the main categories of science that the students learn. This includes life science, earth and space science, and technology and engineering. The science and engineering practices reference a list of 8 total capabilities that students should be learning how to utilize in order to approach scientific investigation and engineering design (M. Dubosarsky, personal communication, April 28, 2020). Lastly, the application component is how students will be taking what they learned and applying it to real world situations (Massachusetts Department of Elementary and Secondary Education, 2016). This helps students better understand the world they live in and how it works. We modeled our assignment to incorporate these three components so that the students at the farm would be able to get the most out of the activity that they could and walk away with new information that could be used outside of the classroom.

2.8: Turn Back Time Farm Mission, Programs, and Current Challenges

It is important that any new facility at Turn Back Time fits into their mission. This makes it imperative that the proposed outdoor shower fills the needs of the farm and uses its design, aesthetics, sustainability, and educational curriculum to fit into the mission of the farm: “To help people recognize nature’s ability to heal and teach” (Turn Back Time, 2019).

According to Lisa Burris, the founder and owner of TBT, the farm has utilized their variety of programs since 2012 to teach children and youth the importance of outdoor play, while engaging them in nature (L. Burris, personal communication, Feb 4, 2020). Such nature-based education, where students learn through unstructured play in nature, improves cognitive functioning and motor skills in children, which in turn, promotes creativity and problem solving, as well as improving overall academic performance (Environmental Nature Center, 2017; Strife & Downey, 2009). Twenty percent of all children participating in the programs at TBT are at risk youth, including children on the Autism spectrum, those who are neurodiverse, and children of families under the poverty line (L. Burris, personal communication, Feb 4, 2020). Studies show that outdoor experiential education encourages youth, including those with special needs, to work together to solve problems and collaborate with other students. This teamwork between children builds social skills and forms connections between the campers and animals at the farm (Weisz & Zaki, 2017). While building these skills the children learn about sustainability and the importance of interacting with the outdoors. A 1994 study showed that learning about the environment and how to take care of it, teaches children how to take care of themselves, resulting in decreased anxiety and depression levels (Wilson, 1994).

In addition to the programs for school-age children, TBT also offers opportunities for college age students attending Worcester Polytechnic Institute, Quinsigamond Community College, and Clark University. These students are able to participate in research projects in a variety of disciplines, including outdoor based STEM education, environmental engineering, and wildlife biology, to name a few. For WPI students, these projects can potentially serve as their Interactive Qualifying Project (IQP) or Major Qualifying Project (MQP) (L. Burris, personal communication, Feb 4, 2020). The IQP is a 7-week project during a student's Junior year at WPI, where they work with a sponsor from around the world to solve a problem or need of the sponsor. The MQP is a full year, senior level project that, while similar to the IQP, is a capstone for a student's major. Both the IQP and MQP are graduation requirements for students at WPI (WPI, n.d.).

2.8.1: Turn Back Time Current Facilities and Needs

Beginning in March of 2021, the farm will begin hosting off-campus IQP's in a yurt village, a campsite that will provide a shelter and amenities for overnight stay. The yurts will

provide students of WPI the means necessary to completely focus on their project by allowing students to live on the farm and incorporate themselves in the environment that TBT has to offer. Overnight immersion of the students in nature will have added benefits, as studies demonstrate that it leads to improvement of interpersonal skills and school performance (Kuh. George, 2014). As TBT expands their current facilities in order to host students for longer periods of time, they are looking for additional facilities that can increase their educational programs, while still being sustainable and useful for the overnight students. Our sponsor believes that a sustainable outdoor shower will fit these needs, with the addition of an educational curriculum that is centered around the STEM concepts of the shower. The shower design will assist the farm in meeting their mission by allowing for the farm's students to learn about nature and sustainability through the outdoor shower (L. Burris, personal communication, Feb 4, 2020).

3.0: Methodology

The goal of our project was to design a sustainable outdoor shower for Turn Back Time Farm to be used by future WPI students, the youth of TBT, and adults who visit the farm. In order to accomplish our goal, we identified the following objectives:

- Research and evaluate outdoor shower characteristics and environmental components that impact the design of an outdoor shower.
- Understand the needs of stakeholders involved in the outdoor shower, including future shower users and Turn Back Time Farm.
- Create simple preliminary outdoor shower designs that lead to the development of one final comprehensive design that fits the needs of Turn Back Time.
- Create an educational curriculum focused around the outdoor shower for use by the children in TBT's programs.

3.1: Research and evaluate outdoor shower characteristics and environmental components that impact the design of outdoor showers.

The first primary source used to meet our first objective was a semi structured interview with Mike Marshall, a farm owner in Idaho who owns multiple outdoor showers. The interview provided us with information on the design of outdoor showers and considerations that need to be made before completing a final shower design. A semi-structured interview was chosen in order to maximize the information we received through two way communication between the interviewee and interviewer (Adams, 2015). Additionally, this type of interview provided us the opportunity to prepare questions ahead of time, but it still allowed us to ask follow up questions when appropriate. The interview was conducted remotely through a video conference call, and during it, we discussed the physical design of the outdoor shower, including wall height, special features, and materials used. We also discussed topics including water source, water heating method, greywater disposal, environmental considerations, and location, with Mr. Marshall providing his professional opinion and expertise on these design considerations.

For secondary data collection for this objective, we gathered data that focused on greywater treatment, water heating options, and environmental considerations of an outdoor

shower. This archival research gave us a better understanding of the methods of heating the water source and how to dispose of greywater in order to meet the needs of the users and the sponsor. We also looked at websites focused on different materials through websites with outdoor shower designs. Decision matrices were used to evaluate the different options provided by the websites and a chart rating the different materials was created to evaluate the varieties of materials available. Materials were rated on cost, strength, aesthetics, maintenance, ease of use, and life span. Additionally, input from our interviewees and sponsor was taken into consideration when making final decisions on these aspects of the shower.

3.2: Understand the needs of stakeholders involved in the outdoor shower, including future shower users and Turn Back Time Farm.

The primary methods of data collection used to meet our second objective were a focus group, a survey, semi-structured interviews, and a site analysis. We conducted a focus group with the Turn Back Time staff in order to understand the needs they have for the shower. A focus group was utilized in order for our team to gain a large amount of information and responses at once (Morgan, 2012). A focus group also allowed for more in-depth conversation and analysis of ideas because of the amount of people in a focus group. During the focus group we discussed topics including how to make the shower educational for children, how to make it appealing for users of the farm, and the location of the shower. We then organized the data and analyzed it to find any main themes or ideas that are useful in understanding the needs of the farm in regards to an outdoor shower.

Additionally, as a primary data collection source, we created a survey for potential users of the shower in order to understand their wants and needs for an outdoor shower. The survey was distributed via email to past, current, and future TBT IQP students because they know the farm and will be potentially using this shower. The questions used in this survey are outlined in Appendix A. They are simple questions about different aspects of outdoor showers and include different shower designs. The survey results were recorded in a spreadsheet and analyzed using graphs and charts; this gave us data about the needs of the users of the shower. We then took the information we gained from the surveys and applied it to our outdoor shower designs.

A semi-structured interview with the owner of TBT, Lisa Burris, was conducted over video conference call where we learned about the needs of TBT pertaining to the shower, as well

as the potential locations for the shower. Multiple interviews with Lisa Burris were conducted throughout the duration of the project in order to ensure the design was being made to the specifications needed for TBT.

After conducting the interview with Lisa Burris, TBT's founder, we conducted another source of primary data collection: site analysis. The site analysis was conducted virtually and in person at the farm. At the farm we were able to visit both potential shower locations and take pictures to document the environment and assets at each area. Virtually, Lisa Burris provided us with information about the two potential locations of the shower. This analysis included evaluations of the size of the area, utilities available, surrounding vegetation, and proximity to the center of the farm. To determine the most appropriate location for the shower at TBT, we made a decision matrix that compared assets and features of each location, including nature immersion, privacy, water access, and sun exposure. Nature immersion and privacy are important design considerations for the users of the shower. Water access is important for TBT for when they build the shower and sunlight exposure is important for the longevity of the shower (M. Marshall personal communication, April 21, 2020; L. Burris, personal communication, March 30, 2020).

3.3: Create simple preliminary designs that lead to the development of one final comprehensive design that fits the needs of Turn Back Time

Our third objective was to use the information from the research, interviews, and site assessment, to develop multiple designs of outdoor showers that would be suitable for TBT Farm. Using our research into the design considerations of an outdoor shower, we developed four preliminary shower designs, having each team member create one design. Each design included dimensions, materials used, and a cost estimate, in order for us to gain an understanding of what each team member believed was important for the design after conducting our research. Once these designs were completed, a design matrix was created that evaluated the four preliminary designs. The matrix compared the designs based on their privacy, size, materials, cost estimate, and any other key features added to that design, such as a bench. From this matrix, we were able to identify key considerations and features that must be incorporated into the shower.

After the preliminary designs, we created one final comprehensive design that fit the

needs of future shower users and TBT. We utilized the information gathered from the design matrix made for the preliminary designs, as well as our primary and secondary research results into greywater management, materials, privacy, and water source to make this final design.

Due to the unseen circumstances of COVID-19, we were unable to build the outdoor shower. Instead, we created in-depth blueprints of the final design as well as instructions for TBT to follow when shower is built. The instructions follow the specific format identified from our research. The directions are listed step-by-step and have images as well as simple instructions to follow. Lisa Burris explained that the builder of the shower will have construction experience, so it would not be necessary to make the instructions extremely in-depth (L. Burris, personal communication, April 2020).

3.4: Create an educational curriculum focused around the outdoor shower for use by the TBT programs and children.

After a number of meetings with Lisa Burris, it became clear that adding an educational aspect to the shower was a key feature that would be beneficial to the children at the farm. In order to complete this fourth objective, we collected data through primary and secondary methods. For primary data collection, we conducted a focus group with the staff of Turn Back Time. We chose to hold a focus group, because we believed that it would give us more insight into what the employees thought of our project, and it would also allow for feedback of our designs and thoughts up to date. In this focus group, we went over topics, such as who will be the main users of the outdoor shower, different possible features to add to the shower to make it more comfortable, and we also tossed ideas back and forth about including an educational component. Both staff members that we talked to stated that having an educational aspect would be a great additional bonus to the outdoor shower (A. Johnston, K. Hunt, personal communication, April 8, 2020).

From our meetings with Lisa Burris, we learned that the kids that come to the farm are in the age ranges of 3-8 and 8-13 (that is, Pre-K to 3rd grade and 3rd to 8th grade respectively). Because of this, we decided to research the education standards of these grade levels to find out what the kids would be learning in school, and how we could create a curriculum keeping in line with that. We used educational websites - both general and local - to see what kids would

typically be learning in each grade. With this information, we were able to make connections with what they learn in school, and what they can learn from the shower. Because we were given two relatively wide age ranges, we chose a specific age group to work with and make activities for based on what they would know and what would be easy for them to comprehend. In addition to doing personal research, we also met with Mia Dubosarsky, the Director of STEM Center Professional Development. She was able to provide us with additional information on what to think about when developing activities for kids, and she recommended resources to use that would make it easier for us to write out a lesson plan in an effective way.

4.0: Results and Analysis

The goal of this project was to design a sustainable outdoor shower at Turn Back Time Farm to be used by future WPI students, youth at TBT, and adults who visit the farm. This section presents data that was collected from our survey, focus group, interviews, material analysis, rainwater experiment, and preliminary designs that resulted in our key findings and final design.

4.1: Survey

The survey was conducted with current WPI students who were asked questions regarding different design considerations of outdoor showers. We received 47 responses from this survey, providing us with information into their wants and needs for an outdoor shower. The following are the results gathered from this survey.

How long do you typically take a shower?
47 responses

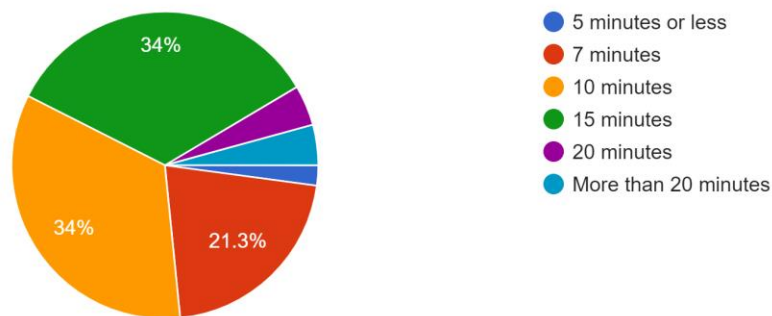

Figure 10: How Long Do You Shower

This question asked survey responders how long they typically shower for. A little over one third (34%) of the people responded that they take either a 10 or 15 minute shower. Less than 20% of respondents shower for 20 or more minutes. This information was taken into consideration when deciding on a water source. This data helped us know how much water people will be using on average, and therefore, how much water we would need available for the user.

Next, we asked survey participants how important eight features of an outdoor were to the participants on a scale of, very important, fairly important, somewhat important, and not important. We then created a bar graph with the results. The following bar graph shows how each participant ranked each feature.

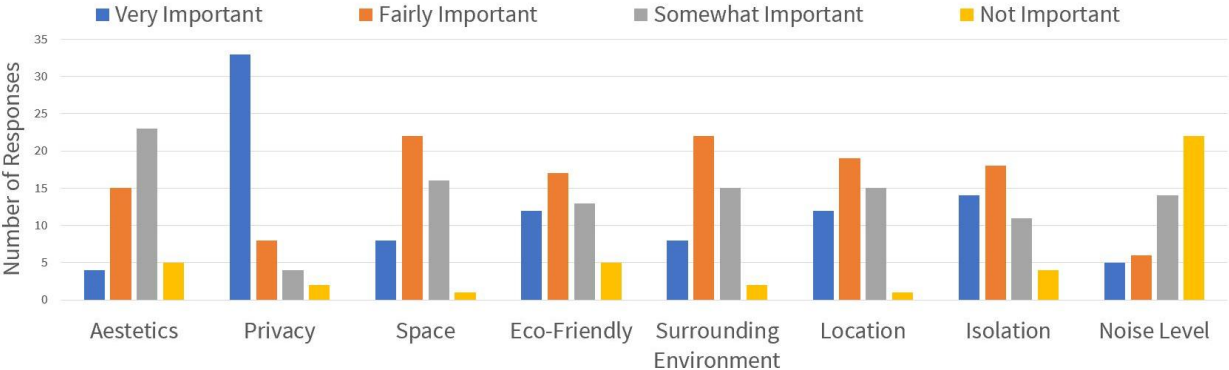

Figure 11: Important Aspects of a Shower Bar Graph

Privacy was the most important aspect of the shower by far, with 33 people saying it was a very important aspect. Many people identified noise level as something that is not important for an outdoor shower, while space and surrounding environment were identified as fairly important aspects of an outdoor shower.

We also asked on the survey what were some of the respondent’s positive and negative experiences with outdoor showers. To visualize the data, we created a word cloud with their responses that can be seen below. The sizes of the words are based on the number of similar responses.



Figure 12: Survey Response Word Cloud

The words in green are the positive things people had to say about the outdoor showers they used, the red words are the things people didn't like about the outdoor shower, and the blue words are suggestions people had to improve an outdoor shower. This question was important in helping us decide what to include in the shower. As seen in the figure, people liked using outdoor showers that felt private, had hot water, and were clean. They did not enjoy when the shower had peep holes, bugs, or was cold. This word cloud gives a visual representation of what is important to the participants of the survey. This information was used to make our final design; words in green are things that are important to include, while words in red are things to avoid in our design.

4.2: Turn Back Time Focus Group

A focus group is a gathering of deliberately selected people who participate in a facilitated discussion of an area of interest (The Balance Small Business, 2020). They are carried out in a conversational style, where the moderators' questions are asked in a natural exchange, and therefore, the participants feel comfortable to interact. Originally, we had planned to have a

focus group with 3 members of TBT, but one became unavailable. Therefore, we held a focus group with two TBT staff members, Ali Johnston and Katie Hunt, to understand the needs of TBT in regards to an outdoor shower at the farm. Due to the mission of TBT being “To help people realize nature’s ability to heal and teach... through educational programs, nature play, and farm education,” Hunt explained the importance that any new facilities at TBT be connected to this mission (Turn Back Time, 2019; K. Hunt, personal communication, April 8, 2020). Hunt and Johnston suggested that the shower design contain an educational curriculum that works around Massachusetts educational standards in order for our shower to match TBT’s mission. They emphasized that an educational aspect would allow for children of the farm to learn from the shower, which would expand the program opportunities of the farm, such as bringing in fieldtrip income, as public school teachers could link their curriculum to curriculum at Turn Back Time (A. Johnston, K. Hunt, personal communication, April 8, 2020).

The focus group also reinforced the importance of privacy and nature immersion for the shower. Hunt and Johnston explained how WPI students are the main stakeholders of the shower, and that it is important they feel secure when using the shower, as there will be pre-school and after-school programs for children taking place at the farm when they use the shower. Hunt explained that students will not want to feel as though children are able to see them showering, but they will still want to feel as though they are immersed in the surrounding natural environment (A. Johnston, K. Hunt, personal communication, April 8, 2020). Finally, when discussing the shower with Johnston and Hunt, they informed us that, for TBT, the most appropriate location for an outdoor shower would be in the woods of the farm near the yurt village. They stated this because the yurt village is where the main users of the shower will be residing, and because that location provides a much more nature immersive experience when using it (A. Johnston, K. Hunt, personal communication, April 8, 2020).

4.3: Interviews

We conducted two main interviews in order to reach the goal of our project. We held an interview with Mike Marshall who is a camp owner in Idaho with an outdoor shower, and Mia Dubosarsky, the Director of STEM Center Professional Development.

4.3.1: Mike Marshall

During our interview with Mike Marshall, we gathered valuable information about his experience with outdoor showers and how certain design elements have worked for him and why others have not. His shower was an 8'x8' shower that was made out of pine. It was one large area, with no divider down the middle, giving the user plenty of space. It was elevated off the ground, with gaps in the floor to allow drainage to occur. He informed us that in his experience, a propane water heater has been the best form of heating. Marshall explored other options for heating, including heating a barrel with the sun and using city tap water. Marshall explained that he ultimately opted for the propane water heater because it was the most reliable and cost-effective method for his outdoor showers, using them for both of his showers (M. Marshall, personal communication, April 21, 2020). In regard to greywater disposal, he explained to us that his showers use a trench filled with drainage rock, where the water flows into the trench and is dispersed into the ground evenly. All of Mike Marshall's showers were built with cedar wood and he advised staying away from using pressure treated woods as they can become slippery when wet. For maintenance of outdoor showers, Marshall applies linseed oil to keep the wood protected from the natural elements and he recommended we use this oil in our own shower design (M. Marshall, personal communication, April 21, 2020).



Figure 13: Mike Marshall's Outdoor Shower (M. Marshall, 2020)

4.3.2: Mia Dubosarsky

Mia Dubosarsky is the Director of STEM Center Professional Development at WPI. She provided us with information about appropriate areas to focus on when developing an educational curriculum for an outdoor shower. During the interview, we learned what is involved in making a lesson plan and that creating an activity was not enough. She explained to us the importance of thinking about what we want the children to learn from the activity, and what the main takeaway or learning outcomes would be. She was able to help us better understand how to read the Science and Technology/Engineering Framework, which is a guideline produced by the Massachusetts Department of Elementary and Secondary Education that outlines what children should be learning in each grade. She highlighted the most important aspects of the document, and she showed us where to find the sections on standards for each grade. Finally, she provided us with three websites that would be beneficial when making activities: PBS Learning Media, Teach Engineering, and the National Science Teaching Association (M. Dubosarsky, personal communication, April 28, 2020). All three sources served as guides and examples of how to teach STEM in a fun and effective way.

4.4 Rainwater Experiment

The rainwater experiment we conducted provided us with data into the amount of water that could be collected during a typical rainstorm. During a 10-hour storm, 2 inches of rain was collected into the bucket, equating to about 1.2 gallons of water. Collecting just 1.2 gallons of water was disappointing because we knew it takes on average about 17.2 gallons of water per shower (Home Water Works, 2011). Water collection is a direct correlation to how much surface area is available for the water to land on. In order to increase the water collection, increasing the surface area of the water collection surface area is needed (Home Water Works, 2011).

The rainwater experiment only provided us with data into the amount of water collected during one specific storm. In order to gather more data on the total water we could collect, we calculated, on average, how much water can be collected in one month in Paxton, MA. These calculations are presented in the table below.

Collection Rate*	Collection Area**	Average Rainfall***	Total Water Collected
.55 Gallons/square foot/inch of rain	26 inch diameter funnel = 1.083 ft radius $\pi(1.083)^2 = \mathbf{3.69}$ sqft	5.0 inches/month	10.1 gallons/month

* Source: (Plum Creek Conservation District, 2006)

** Source: (Amazon.com : Flexible flyer 3-pack snow saucer sleds.n.d.)

*** Source: (Weather underground weather history.)

Table 3: Water Collection in Paxton, MA

The calculations demonstrated that a rainwater catchment system at TBT would provide the shower with a total of 10.1 gallons per month. After this calculation was completed, we calculated the total savings that this amount of water would provide for TBT. These calculations are presented in the table below.

Water Prices*	Gallons of Water	Savings
\$8.9567/1000 gallons = \$0.00895 /gallon	10.1 gallons/month	\$0.09 / month

* Source: (Paxton, 2017)

Table 4: Savings per Month

As shown in table 4, TBT would save only nine cents per month on water costs while using a rainwater catchment system for the outdoor shower instead of completely using tap water from the town of Paxton. The cost of the system would be over \$300 to build, meaning it would take over 277 years for the savings in water to outweigh the initial cost to build the system (Lowes, 2020).

4.5 Material Analysis

We created a decision matrix (Table 5) for different types of wood we could possibly use to construct the shower. Each material was compared to each other based on cost, strength, aesthetics, maintenance required, ease of use, and untreated life span. These categories were

chosen because when conducting our background, they were identified as elements of wood that need to be taken into consideration when choosing a material. Each category was ranked out of 5 points, with 5 being the best for each category. We chose to rank it out of 5 because we wanted to rank each material from best to worst.

Materials	Cost^{a,b}	Strength^b	Maintenance^b	Ease of Use^b	Life Span^c
Western Cedar	5	3	3	5	3
Redwood	2	3	3	5	2
Cypress	4	3	3	5	1
Mahogany	1	5	5	2	4
White Oak	3	4	5	2	5

a: Based on prices on homedepot.com

b: source: Wood Magazine, 2016

c: source: Eric Meier, 2020

Table 5: Materials Decision Matrix

This decision matrix helped us decide which materials would be the best for us to use. We knew we wanted material that was inexpensive, able to withstand the New England weather, and fit into the farm’s environment. Using this matrix, we were able to see which materials fit these criteria the best and what we would need to sacrifice if we chose a certain material. When creating this decision matrix, we placed the columns in order of importance to our outdoor shower design. By doing this we were able to eliminate any low scoring materials in the first few columns and use the latter columns to differentiate the remaining materials.

4.6 Site Analysis

The site analysis consisted of comparing two potential locations for the outdoor shower at Turn Back Time to determine the most appropriate location for our shower. The first of the two locations was situated next to the new bathhouse at TBT and was in close proximity with the outdoor kitchen, barn, and garden. The second location was more remote, being located near the yurt village in the woods of TBT, as shown in figure 14 below.

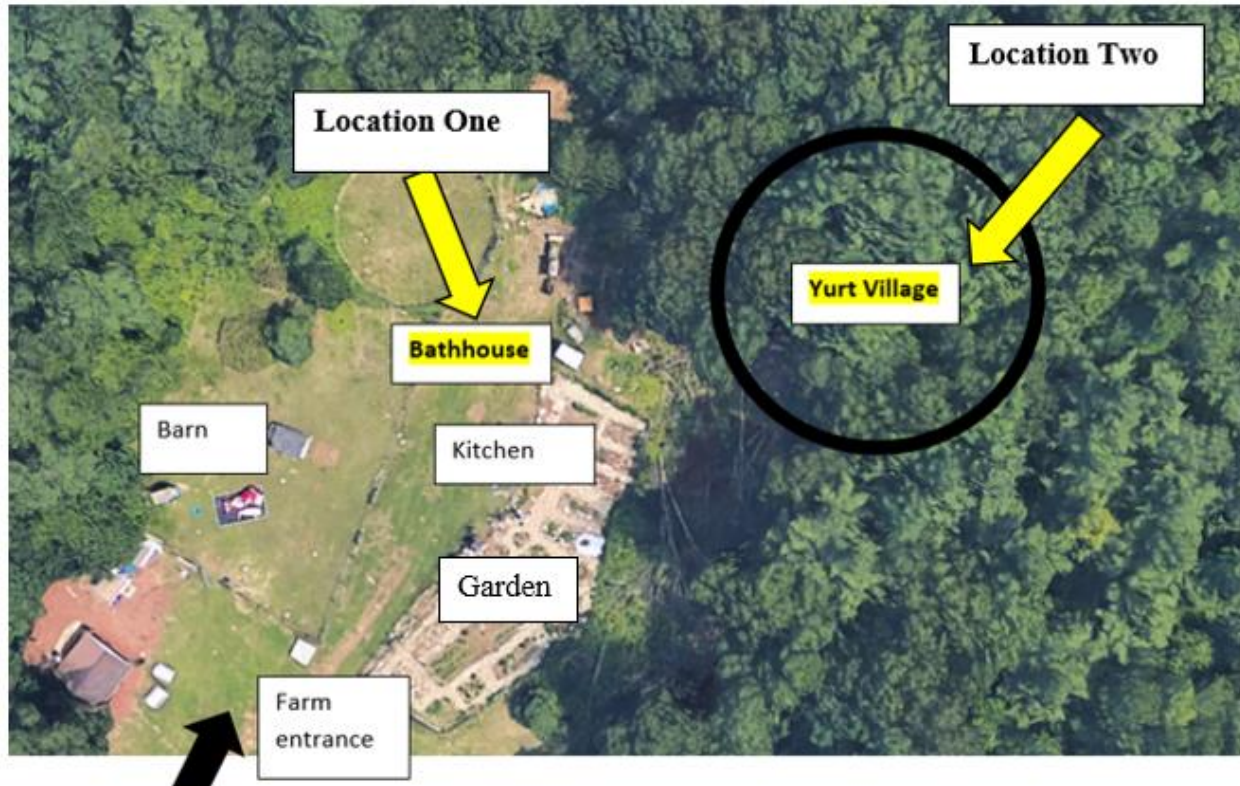

Figure 14: Farm Layout

Additionally, when conducting the site analysis virtually, we asked Lisa Burris to provide us with information on the different assets in each location. These assets are described in the comparison matrix below. In this matrix, the two locations are compared directly. Items highlighted in green are the more beneficial option in that category and conversely the items in red are the less beneficial option.

	Location One (Next to bathhouse)	Location Two (Near the Yurt Village)
Nature Immersion	Little available as this location: directly next to a building	Very immersive: surrounded by trees and nature, as it is in the woods
Ease of Water Access	Very simple. Tap water can be used straight from the bathhouse*	Complex. Tap water requires hundreds of feet of housing. *
Privacy	No. Located close to the center of the farm where children learn and play	Yes. Remotely located in the woods along the perimeter of the farm
Sunlight Exposure	Direct sunlight for multiple hours of the day*	No direct sunlight. Mostly covered by shade
Electricity Available?	Yes	No
Close to main stakeholders staying in the Yurt Village	No	Yes

* Source: (L. Burriss, personal communication, March 23, 2020)

Table 6: Location Comparison Matrix

In addition to creating the comparison matrix, we consulted with Lisa Burriss as to which location she would prefer for the shower. Due to the circumstances surrounding COVID-19, we are not able to visit the farm. Therefore, Burriss understands the locations more in-depth than we were able to. Burriss informed us that she believes the shower should be constructed in the woods of the farm near the yurt village, as this location provides easy access for the WPI students to use it and because that location is exceptionally private (L. Burriss, personal communication, April 27, 2020).

4.7 Preliminary Designs

Utilizing the results from our research and interviews, we created four initial outdoor shower designs to present to Lisa Burris, the owner of Turn Back Time Farm. From a semi-structured interview with Burris and our survey, we learned that the most important aspect of the shower for TBT is having a feeling of privacy while using it (L. Burris, personal communication, March 30, 2020). The designs were created with an emphasis on the privacy of the shower in order to match the needs of the farm. Below are the four initial designs that were developed.

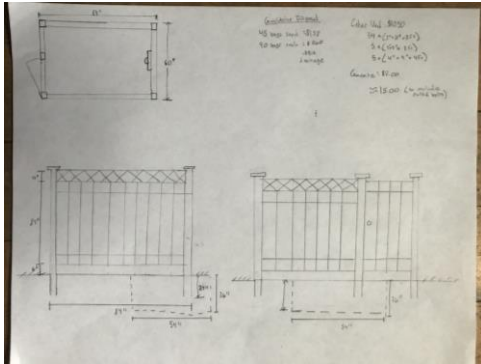

Figure 15: Zach's Design

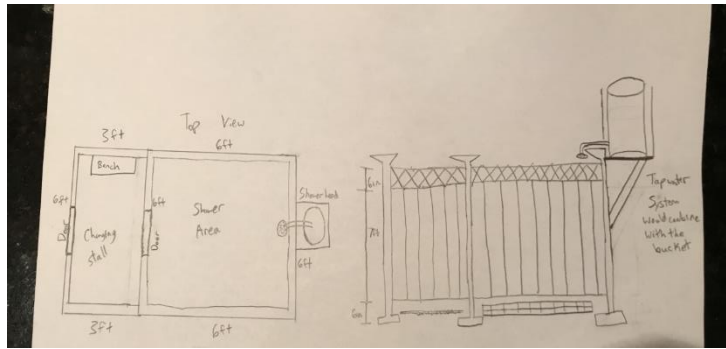

Figure 16: Aaron's Design

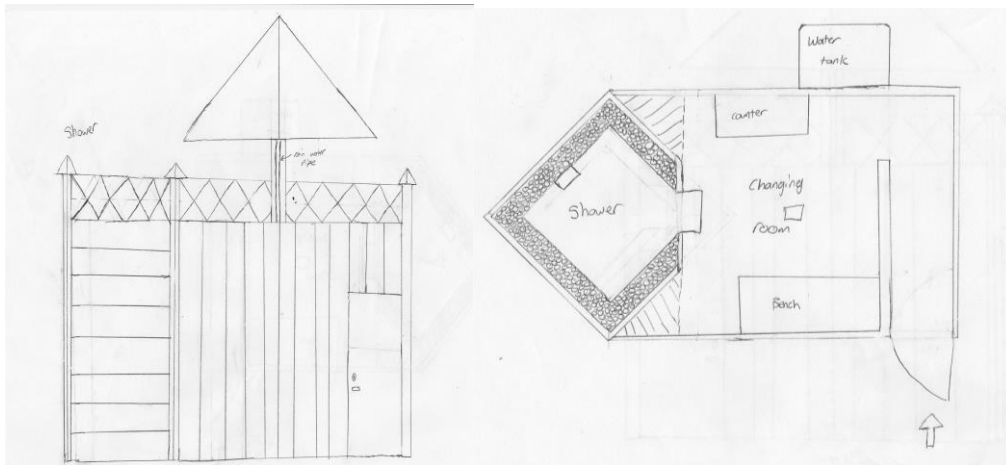

Figure 17: Andy's Design

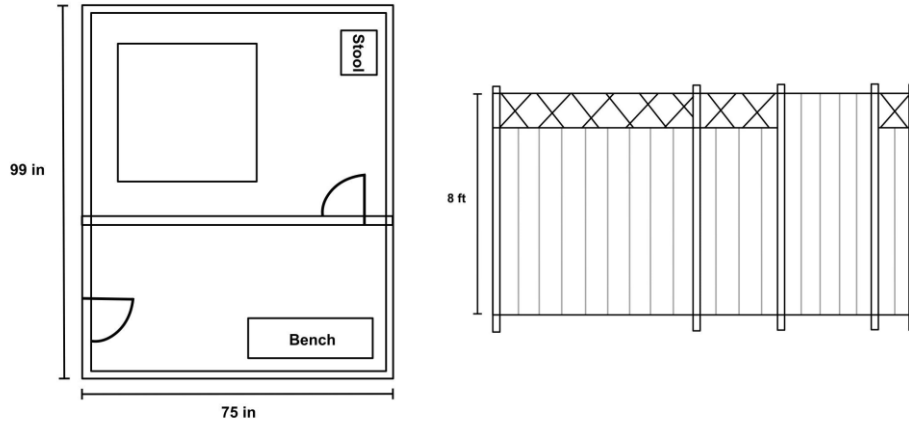

Figure 18: Dalila's Design

After the completion of these designs, we created a decision matrix to compare the designs. The designs are compared based on their privacy, cost estimate, size, materials, and any additional features that the shower has. Blocks highlighted in green are more optimal aspects or considerations for the final outdoor shower design, while items in red are less optimal. The yellow block indicates that most features in the block are favorable, with the non-favorable aspects within that block in red. Cost estimates greater than \$2000 are in red. Below is the table created.

	Privacy*	Cost Estimate**	Size ***	Material Rating	Additional Features
Aaron	High 7' walls. Locked Door	Wood estimate alone: Cedar: \$1050 Pressure Treated: \$252.23	One stall 60"x84"	Cedar with pressure treated posts	Lattice structure extending 1' above walls

Zach	8' tall walls with doors with locks	Cedar: \$1,161.06 Pressure Treated: \$667.43	2 stalls Shower stall: 5"x5" Changing stall: 3"x5"	Cedar with pressure treated post	No Lattice. Bench inside changing stall with hooks and shelves/ things to put clothes on
Dalila	Doors with locks, high walls (8' tall)	<u>Cedar:</u> \$1,501.66 <u>Pressure Treated:</u> \$812.98	99"x75" 2 stalls Shower: 4'x6.25' Changing area: 4.25'x6.25'	Cedar	Lattice panelling on top, bench in the changing area with hooks and stool
Andy	High 8' tall wall, door with lock, A walkway so the door when the door opens you can't see the changing room, walls go into the ground	<u>Cedar:</u> \$1,200 <u>Pressure Treated:</u> \$880	1.5 stalls Shower: 5' x 5' Changing Area: 5' x 6.25' Walkway: 3.125'x6.25'	Cedar	Lattice panelling on top, hooks, bench, counter/shelf, possibly a roof over the changing room

*Describe the features that make the shower secure and private

** Cedar boards--- 4"x4"x8' (3.5"x3.5"x8') - \$37.27, 1"x8"x8' (0.75"x7.5"x8') - \$20.16

Pressure treated--- (3.5"x3.5"x10') - \$12.57, (0.75"x3.5"x10') - \$5.57

*** How large is the shower? One or two stalls?

****Based off the Materials Analysis Chart

Table 7: Comparison Matrix

The comparison matrix we created for these designs allowed for us to see the important aspects that each design had, and the approaches taken to create a sense of privacy and security. Most designs use a two stall system, highlighted in green under size, allowing for a dry area for people to change. The comparison matrix highlights important features to include in the final design, including a lattice structure on top of the high walls at least six and a half feet tall, a bench, and cedar walls as described in the materials section. Additionally, after analyzing shower kits from Cape Cod Shower Kits and our background research , we concluded that the walls of our shower needed to be at least six and a half feet tall to provide a minimum level of privacy for users (Cape Cod Shower Kits Co.). Mike Marshall also explained to us that his outdoor showers have seven foot walls to provide enough privacy for users (M. Marshall, personal communication, April 21, 2020). These four designs and the decision matrix were then used to create the final shower design.

5.0: Design Considerations

This section discusses the findings of our research based on our results. We were able to take the data we received from our results, and translate that into our findings that we later incorporated into our shower design.

5.1: Shower Location

The outdoor shower designed for TBT should be placed in the woods of the farm in the vicinity of the yurt village. With the shower's main users being the future WPI IQP students, it was important to place the shower near the yurt village, as this is where the students will be staying. Below you can see the approximate location of where the yurt village and outdoor shower will be. Turn Back Time will determine the exact location of the shower within the circle below during the construction of the shower (L. Burris, personal communication, April 27, 2020).



Figure 19: Shower Location

The site analysis supported the decision to place the shower in this location. As shown in our results, our survey responses identified that one of the most important aspects of an outdoor shower is privacy. The focus group also emphasized that privacy is a priority for the shower due

to the daily schooling programs happening nearby the shower (A. Johnston, K. Hunt, personal communication, April 8, 2020). The comparison matrix from the site analysis showed us that the location in the woods would provide shower users with the greatest amount of privacy, as it is farthest from other programs happening at TBT and other buildings on the farm. This location also provides the greatest acoustic and visual privacy, two topics discussed in the background. The ambient noise of the woods provides a greater sense of acoustical privacy and the distance from main farm buildings allows for a sense of visual privacy, as the area is not heavily trafficked (Contract Environments, 2014).

This location also provides the greatest nature immersion by being surrounded by nature. As demonstrated in the comparison matrix in our site analysis, the other location considered is solely surrounded by buildings, providing no nature immersion. Nature immersion was another important aspect of the shower demonstrated through our survey. Respondents indicated the importance of having a nature aesthetic and being able to listen to the surrounding natural environment. This shower location also will provide the benefits of nature immersive education as described in the background section.

Finally, when consulting with TBT owner, Lisa Burris, she indicated her preference for the outdoor shower being the location near the yurt village, ultimately solidifying our choice to design the shower in that location. While this location does not have easy access to water or electricity, Lisa Burris informed us not to consider those aspects very heavily because piping the water to that location would not be difficult and because it will likely not need electricity. Additionally, Ms. Burris prefers the shower be designed in this location in order for the WPI students to have easy access to the shower and so they are not disturbed by school programs at the farm (L. Burris, personal communication, April 27, 2020).

5.2: Greywater Management

For our outdoor shower, it was determined through archival research and interviews that a dry well is the most effective technique to filter the greywater from the shower. The dry well was chosen because it is a simple technique of filtration that consists of a hole dug into the ground, and it then is backfilled with natural materials allowing for the water to be dispersed evenly into the surrounding soil, as shown below in figure 20.

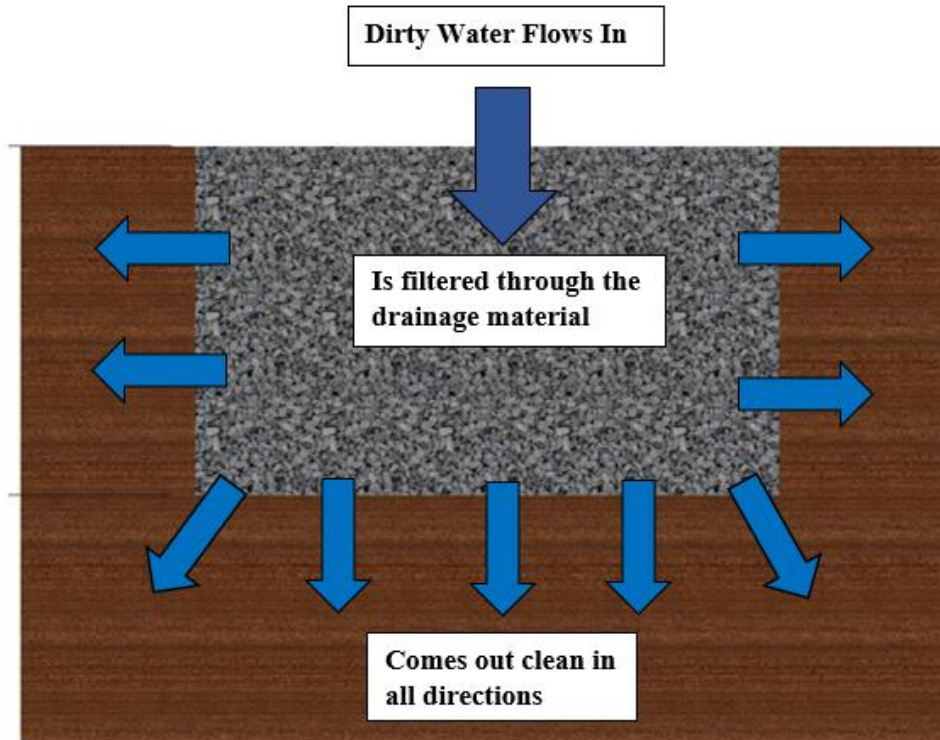

Figure 20: Dry Well System

As discussed in the background, a dry well uses natural materials to filter the greywater before it reaches the surrounding soil, making the dry well environmentally friendly. Additionally, our research in the background demonstrated that a dry well is more effective in removing contaminants in the water and less expensive than a French drain, the other option considered.

The dry well for our outdoor shower should be 4'-2.5" x 5', to cover the splash area from the shower, while leaving ample space to place the walls. The dry well should be dug three feet into the ground and then backfilled with drainage rock, one of the most common natural materials used in dry wells (Bob Vila, 2016). See images 21 and 22 below.

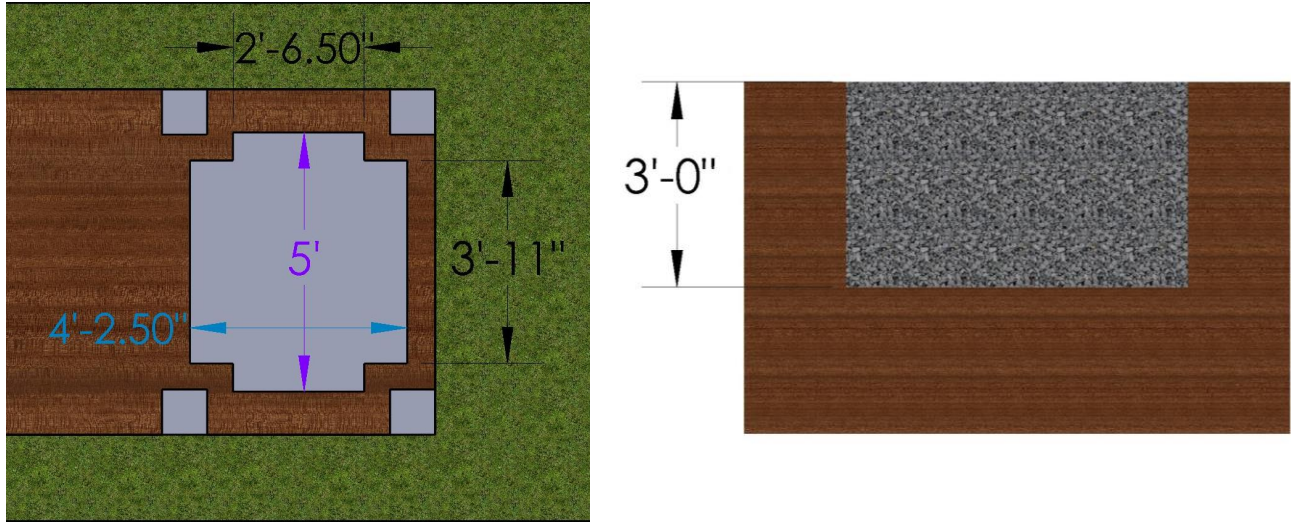

Figure 21 and 22: Dry Well Dimensions

The drainage rock will filter out harmful materials from the greywater and prevent them from permeating into the earth and harming the soil (Wurochekke et al., 2016; Dalahmeh et al., 2012). Additionally, through semi-structured interviews it was determined that this technique of greywater drainage is one that is specifically used when constructing outdoor showers (M. Marshall, personal communication, April 21, 2020).

5.3: Water Supply

The outdoor shower at TBT should be supplied with water through one main method, tap water. Tap water will provide the shower with a constant supply of clean fresh water, that users should feel safe showering in. Our survey results showed that users of the shower do not want to have to worry that the quality of the water is not clean or safe for use. These survey results and communication with Lisa Burris allowed for us to rule out using the Beaver Pond as the water source for the outdoor shower. Lisa Burris communicated that the beaver pond water has varying levels of cleanliness at different times of the year and was worried about the water being filtered correctly. Additionally, Mrs. Burris explained how the pond has dried out in past summers, and she does not want to risk this happening again by taking water from it for the shower (L. Burris, personal communication, April 13, 2020). Rainwater was another option we considered when deciding on the water source. In our background, we discussed how studies show that rainwater is safe and requires no filtration for use in a shower, making it a very viable option for our

outdoor shower (Li, Boyle, & Reynolds, 2010). The only filtration needed would be a mesh covering to keep any sticks or debris out of the water system. However, after performing our rainwater experiment (calculations as discussed in the results), we concluded that it should not be the main water source. Through this experiment and the calculations performed, it was determined that no more than 10 gallons per month could be collected for use at the outdoor shower. This means that the rainwater would not provide even one full shower a month, as the average shower uses 17.2 gallons of water (Home Water Works, 2011). These results made the rainwater option also not suitable for use as the water source, resulting in the decision to make tap water the main water source for the outdoor shower.

5.4 Rainwater Catchment System

It was concluded that rainwater would not be the main source of water for our outdoor shower design at TBT. However, Lisa Burris communicated with us that she admired the fact that rainwater could be used for the shower with little filtration. She explained that if it could be included in our design then a rainwater catchment system would be an added sustainable selling point and educational element of the shower for new farm visitors (L. Burris, personal communication, April 27, 2020). Due to this, we decided to include a rainwater catchment system into the design of the shower that can be added to the shower at any point after the initial construction of the shower. Below is the rainwater catchment system we designed.

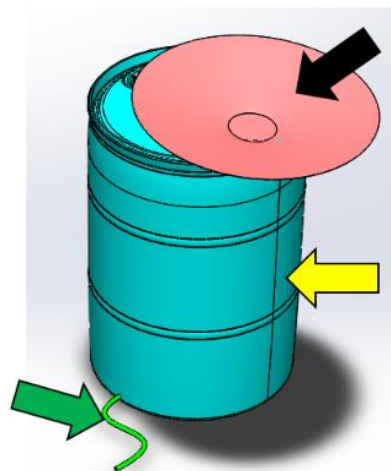

Figure 23: Rainwater Catchment System

Color	Corresponding Part
	Irrigation hose that connects to shower
	55 gal. barrel
	26" Sled acting as funnel

Table 8: Rainwater Collection System

The design was made simple in order to keep the cost as low as possible. Research from the background demonstrated how the larger the collection area for the rain, the more water that will be collected for use. As a result, the design includes a large plastic sled, as seen above, that is used as a large funnel that collects the most water possible (Plum Creek Conservation District, 2006). The only modification needed to be done to the sled it to cut a hole in the middle of it, so the water could flow down into the bucket easily. This funnel collects the rainwater, filtering out any large particles, such as sticks and leaves. This will be done with a mesh that covers the hole in the sled and only lets the water through. The water collected is stored in the barrel, from there it is pumped up to the shower for use. The tap water is piped to the shower from a central location, presumably the new bathhouse. The pipes from each source (rainwater and tap water) meet up at a “Y connector” where the user is able to switch from rainwater to tap water when necessary.

5.5: Water Heating Method

The outdoor shower at TBT should be heated using a portable propane water heater. Survey respondents and Lisa Burris both emphasized the need for hot water at the shower. A comparison matrix was made to evaluate the different water heating options. This can be seen below. Boxes highlighted in red are negative requirements of a heating method, while boxes highlighted in green are positive.

	Propane Water Heater	Compost Water Heating	Water Heating from Central Heating System	Direct Solar Heating Using a Container	Solar Flat Plate System
Requires Electricity?	No*	No	No	No	Yes
Long Piping?	No	Yes**	Yes	No	No
Requires Sunlight	No	No	No	Yes	Yes
Requires Additional Water Pump	No	Yes	No	Yes	Yes
Maintenance	Little to none	High	Little to none	Medium***	Little

*Requires one battery to initially turn system on, then uses no electricity.

**Depending on where the compost pile is located.

***Requires cleaning of storage tank when needed.

Table 9: Water Heating Comparison Matrix

This comparison matrix was made using the information gathered in our background, and its results show that the portable propane water heater is the best choice. Each water heating method was evaluated on its necessity of electricity and a water pump, the amount of piping needed, sunlight requirements, and maintenance requirements. The propane water heater is the only option with five green boxes, providing a visual representation that this method is best for heating the outdoor shower at TBT. Compost water heating requires extensive maintenance and an additional water pump to transfer the water to the shower, making it not a suitable option (Ross, 2018). Lisa Burris informed us that water heated from the central heating system would

not be feasible for our outdoor shower due to the large amounts of piping needed to transfer the water, which are also very expensive (L. Burris, personal communication, April 27, 2020). Finally, both the direct solar heating option and the solar flat plate system require ample amounts of sunlight to work effectively, making them not appropriate options as the outdoor shower will be located in the woods under lots of shade (Esen & Esen, 2005). Additionally, in our interview with Mike Marshall, he explained how he has used portable propane water heaters for his outdoor showers, and that they have proven to be an effective and reliable method of heating tap water (M. Marshall, personal communication, April 21, 2020).

5.6: Materials

For our outdoor shower, the material used needed to be rot resistant, insect resistant, weather resistant, and water resistant because it will be in the woods. Natural softwoods, such as cedar and cypress, and hardwoods, such as oak and mahogany, are good materials for this application. We also explored composites, but they were 2-3 times as expensive as softwoods and would not look natural in an environment surrounded by nature (Wood Magazine, 2016). We ended up constructing a decision matrix (table 5) with all of our wood options. We compared these materials, based on cost, strength, maintenance required, ease of use, and untreated life span. After creating this decision matrix and interviewing with Mike Marshall, we concluded cedar and white oak were the two best options. Cedar compared to white oak is about half the price, but not as strong or durable. We ultimately chose cedar due to the price difference. An 8' board of cedar is about \$15 cheaper (8' boards) than white oak (Lowe's, 2020). This is a very big deal since we need 76 of those boards (\$1140 difference) and we tried to keep the budget as low as possible for the farm. We were willing to sacrifice strength, since the wood in the shower will not be under any loads, and we were also willing to sacrifice durability, since wood can be treated to prolong deterioration.

6.0 Final Shower Design

To reach our goal, we created the following outdoor shower design and rainwater catchment system. Figure 24-26 are 3-D renderings of our final designs for TBT.

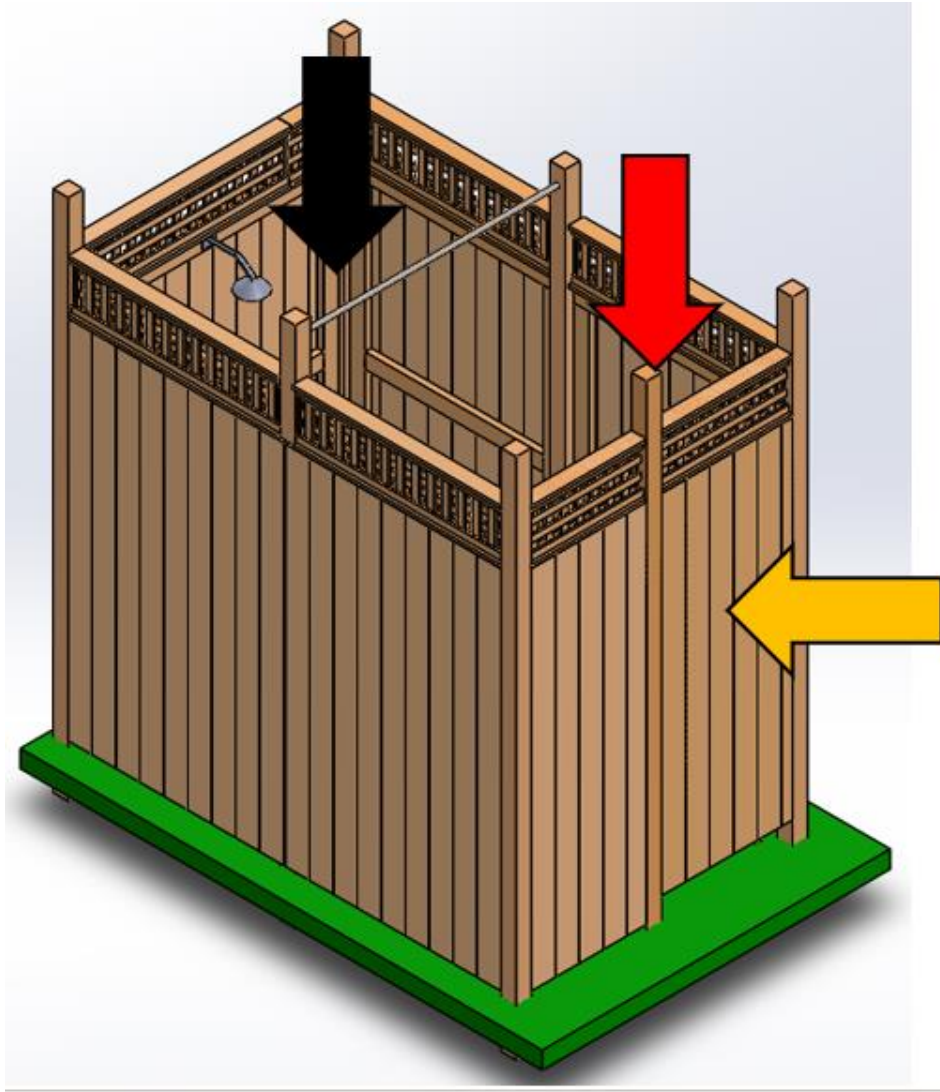

Figure 24: Shower Isometric View

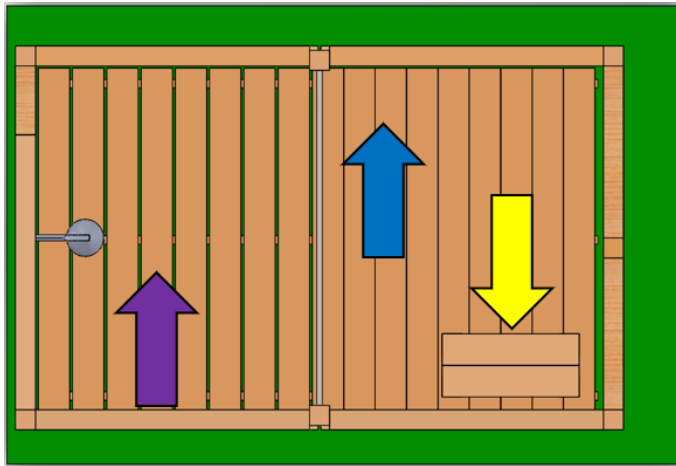

Figure 25: Shower Top View

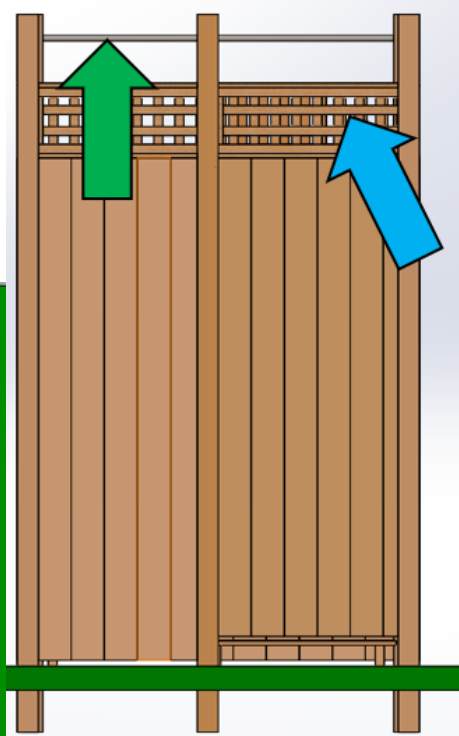

Figure 26: Shower Front View

Colors	Corresponding
Black	Shower Area
Red	Changing Area
Yellow	Door
Purple	Separated floorboards in the showering area
Blue	Flush floorboards in changing area
Cyan	Lattice structure
Green	Shower curtain rod
Yellow	Bench

Table 10 : Final Shower Design

These images of the final outdoor shower design show an isometric, top, and front view of the shower. The arrows indicate key design aspects of the shower using the color of the arrow. The shower design was created using the findings described in the previous section and from the results of our research. The shower should be placed near the yurt village and made entirely of cedar wood because it is naturally rot and insect repellent and features two 5'x4' sections, one for showering and one for changing. The changing space was identified as an important feature

of the shower. Additionally, our focus group and survey emphasized the importance of a changing space. The two sections create one large 5'x8' shower enclosure that provides ample privacy and space, two main features of the shower as identified from our survey, for the variety of users the outdoor shower will host. To support the shower, 4"x4" posts are cemented into the ground at every corner. The seven foot walls of the shower are then attached to these posts. These walls are constructed with 2"x4" cedar boards as a frame and then 1"x6" boards are placed on the frame to form the wall. To reduce the final cost, the two sections of the shower are separated by a shower curtain in the center of the enclosure rather than a wall. The shower features 7' walls with an additional 1' of lattice structure on top of the walls; additionally, all boards of the walls are flush with one another. This allows for maximum privacy when showering with the added aesthetic of the lattice structure. The floor is also made from cedar boards, with space between each board in the shower area to allow for water to flow into the necessary greywater disposal system, a dry well filled with drainage rock, beneath the shower. The floor in the changing area of the shower has boards flush with one another giving a more solid feeling for when users are changing. Finally, the shower features a bench and hooks in the changing area, a lock on the inside of the door for security, an educational aspect and a rainwater catchment system that adds to the sustainability of the shower, two very important things to TBT.

The final cost of the shower was calculated using only the essentials needed to build the shower. We were told by Lisa Burris that all the additional amenities such as mirrors, hooks, and shelves could be bought after construction and did not need to be included in the final budget (L. Burris, personal communication, April 27, 2020). As seen below, the final cost of the shower comes to approximately \$2131.68. On the right side of the shower budget, are the cost estimates of the two add-ons: the lattice structure and rainwater catchment system.

Shower	Count	Price (dollars)		Water Catchment System	Count	Price (dollars)
Irrigation Hoses	200ft	32		55-Gallon Barrel w/spout	1	71
Shower Curtain Rod	1	10		Water Pump	1	83.6
Shower Curtain	1	30		Sled for Water Funnel	1	15
Cement	75lb	51.5		Wire Mesh	5 sq in	10.98
Screws	about 500	60		Additional Hosing	50ft	5.98
1"x6"x8' Cedar Boards	77	1,133.44				
4"x4"x12' Pressure-Treated Boards	8	127.84		Total		\$186.56
2"x4"x8'	28	279.16				
Drainage Rock	2.5 cubic yard	45		Lattice Structure		
Propane Water Heater	1	139.99		4'x8' Pre-Made Lattice	2	31.76
Copper Piping	40ft	35.48		2"x4" Cedar Boards	7	69.79
Shower Handle	1	38.48		Screws	100	10
Shower Head	1	5				
Hose Splitter	1	10		Total		\$111.15
Sharkbite 1/2 in. Pipe Fittings	15	110				
Pipe Straps	20	10.15				
Door Lock	1	7.48				
Door Hinges	2	6.16				
Total		\$2,131.68				

Table 11: Overall Budget

6.1: Instructions for the Design

Due to Covid-19, we were not able to construct the outdoor shower. Instead we developed a detailed set of instructions for whomever will be constructing the shower. Lisa Burris communicated with us that the person who will be constructing the shower will have basic construction knowledge and experience in building (L. Burris, personal communication, April 27, 2020). This resulted in our instructions being more of a guide instead of extremely detailed instructions. The instructions (Appendix D) included detailed drawings with dimensions of each piece. They are supported with bulleted directions that will help the builder explain the steps of the building process. They do not include instructions like where to place screws or how to connect each piece.

When writing the instructions, we made sure the reader could understand the process and visualize the end result. Since we are not constructing the shower ourselves, we needed to make them as clear as possible so they can be interpreted correctly. One way we did this is by splitting the instructions into sections, and also by making sure each new section builds on the last section. At the end of the instructions, we included recommendations on how TBT can maintain the shower over time, as well as additions that can be made to shower, including the lattice structure and the water catchment system.

To better help the builder understand our instructions we included blueprints and visuals,

from the perspective of the builder, with clear and short lines of text in each section. The illustrations will help the builder visualize exactly what we had in mind for each section (Last, S. 2019). We also included isometrics views, that allow the builder to see the drawings in a three dimensional visual on two dimensional instructions, in each section. This allows the reader to see how each section should look once constructed. These instructions are located in Appendix D.

7.0: Educational Components

For the educational components of our outdoor shower, we created two different experiments to be conducted by children at TBT. The experiments are linked to STEM concepts associated with the outdoor shower. The focus group we conducted with TBT staff members reinforced that it was important for the shower design to include an educational curriculum. The focus group emphasized that an educational curriculum would allow for the shower to match TBT's mission (A. Johnston, K. Hunt, personal communication, April 8, 2020). Additionally, after meeting with Mia Dubosarsky, the Director of the STEM Center Professional Development at WPI, we were able to gain more insight into what goes into a lesson plan and how to make one for the main grade level that we chose to focus on, fifth grade.

7.1: Water Filtration Experiment

Because we were to make an activity that was related to an outdoor shower, we decided that the activity should be something that explains one of the many processes that take place in the proposed outdoor shower at TBT. In this case, we chose greywater recycling. Since greywater recycling is still a broad topic, we decided to narrow it down more and pick a smaller process within greywater recycling: filtration. This activity is ideal for nature-based education because it incorporates natural materials, exemplifies a procedure that happens around us constantly, as well as a process that will take place in the outdoor shower.



Figure 27: Water Filtration Activity Diagram

Level: 5th Grade / 6th Grade

Learning Areas: Earth and Space Science

Objective(s): For children to learn about greywater versus blackwater, and to design and construct a makeshift water filtration system. Through watching a video, children will gain an understanding of new vocabulary. Children will also identify a problem and design solutions accordingly.

List of Materials:

1 Empty Water Bottle

1 Pair of Scissors

1 Rubber Band

Coffee Filters

1 Cup of Dirty Water

Sand

Gravel

Rocks

Tape (optional)

Description:

1) First, have the children look at a [short informational video](#)⁵ about waste water recycling.

After the video ends, have a class discussion answering the following questions:

- a) Why do we need to be smarter and more innovative about our water use?
 - b) What is waste water?
 - c) What is the difference between greywater and blackwater? Are they recycled and reused in the same way?
 - d) What are some of the benefits of recycling waste water?
- 2) Start the filtration activity
- Have a cup of dirty water (can be water mixed with dirt).
 - Use scissors to cut the water bottle just above halfway.
 - Take the top half of the bottle and replace the bottle cap with a coffee filter. Secure the filter on top of the bottle with a rubber band.
 - Fill the top half of the bottle with whatever materials you want (just make sure there is enough room on top for water to flow).
 - Put the top of the bottle securely in the bottom opening (use tape if needed).
 - Pour the dirty water into the makeshift filter.
 - Observe. They should be able to see the resulting water come out clearer than before.
- 3) Have the children redo the experiment with different materials such as a paper towel instead of a coffee filter, ground up charcoal and cotton and reflect on why the outcome is different.

Resources: [Waste Water Recycling](#)⁵ (Waste water recycling: Fresh solutions.2020)

7.2: Water Cycle in a Bag

Since water is the main resource used to shower, we decided to design an assignment around the water cycle. This activity will teach the children about the phases of the water cycle and how to recognize them.

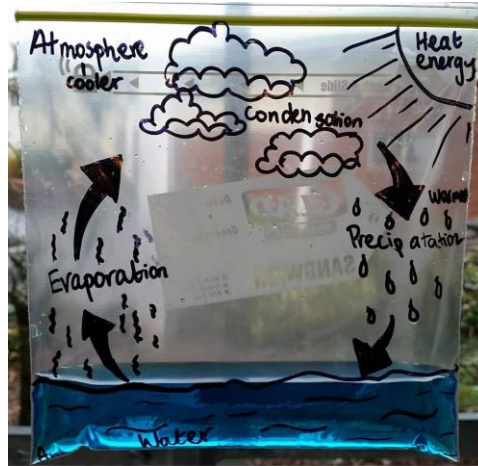

Figure 28: Water Cycle in a Bag
(Robolabz, 2016)

Level: 3rd Grade / 4th Grade / 5th Grade

Learning Areas: Earth and Space Science

Objective(s): For children to learn about the water cycle. Children will develop a model and make observations to describe the phases of the water cycle.

List of Materials:

1 Ziploc Plastic Bag

Food Coloring

Water

Permanent Marker

Clear Tape

1 Cup

Description:

- 1) First, read the Sun and the Water Cycle story⁶ to the class, as provided in the resources below, and lead a discussion on the phases of the water cycle and how the water cycle is important.
- 2) Begin the activity:

- Decorate the Ziploc bag with the permanent marker. Include important elements of the water cycle such as clouds and the sun.
 - Prepare the Water. Fill a cup with clear water and then add some drops of food coloring (the color could be blue to represent rain or a color of your choice).
 - Pour the Water. Once the water is colored properly, pour it into the Ziploc bag. Close the bag and make sure it's tight!
 - Hang It Up. Now that you have the bag with food coloring, hang it up on a window with clear tape. Make sure it can be exposed to sunlight.
 - Wait and Observe. After about an hour, depending on how much sunlight there is, you will begin to see water droplets forming on the sides of the Ziploc bag!
- 3) Discuss with the class what is happening with the water in the plastic bag and what it is an indication of.

Resources: [The Sun and the Water Cycle](#)⁶ (PBS LearningMedia, 2020)

8.0: Recommendations

In this section our recommendations for TBT are presented based on our findings and results. The section contains the instructions for blueprints, maintenance recommendations, and parts we believe work best for the outdoor shower. These recommendations will give Turn Back Time the information needed for when they decide to build the outdoor shower.

8.1: Blueprints and Construction

The blueprints and instructions for the construction of the shower are located in Appendix D. These blueprints will guide the builder to properly construct the shower that we designed for Turn Back Time. All dimensions for cutting wood and instructions for properly piecing together the shower are located on the blueprints and are able to be followed easily through the use of text and images. Additionally, in order to build the shower, the materials list is needed; this is located in Appendix C. As for the instructions for the lattice structure and rainwater catchment system, they are located in Appendix E and F, respectively. These blueprints are laid out similarly to the ones of the full shower design.

8.2: Maintenance

To ensure that the shower lasts for many years to come, it is important to keep the shower clean and do maintenance every year. At the beginning of each year, it is important to do a deep clean to get the shower ready for people that may use the shower. We also suggest doing a deep clean multiple times throughout the summer, knowing the shower will get pretty dirty. For the wood we suggest treating it with a non-toxic wood preservative. The preservative will help prevent mold from building up on the surface of the wood and help the wood last longer without using any harmful chemicals. A good non-toxic wood preservative is Eco Wood Treatment. It only needs to be applied once and will give the wood an aged greyish look. If the appearance is a problem, you can instead use linseed oil or Tung oil. These oils are good wood preservatives, but need to be reapplied every couple of years. The differences between these two oils are linseed oil takes a long time to dry (up to 10 weeks) and turns yellow over time, while Tung oil has a distinct odor and needs multiple coats when being applied. We also looked into using pressure treated wood and shou sugi ban, but we found that pressure treated can get very slippery

when wet, due to the injected chemicals (this would not be good for our shower, as it could be a safety hazard), and shou sugi ban requires experience to get the technique right (M. Marshall, personal communication, April 21, 2020). Mike Marshall also suggested using eco-friendly soap in the shower that will help preserve the wood and the different materials inside the shower (M. Marshall, personal communication, April 21, 2020). Eco-friendly soaps contain no chemicals or anti-bacterial ingredients such as phosphate and triclosan (OARS Companies Inc, 2018). We suggest using Sea to Summit Wilderness Wash, a popular ecofriendly soap, that is free of phosphates and triclosan (Sea To Summit, n.d.). The link to the soap is located in Appendix G. Finally, our shower should be outside in the woods with no roof, so leaves and sticks will need to be removed from the shower to keep it clean for users. It is best to do a simple check up every day before anyone uses it to clear any debris or other natural elements from the shower before use.

8.3: Suggested Parts

The parts below are the ones we suggest using for the outdoor shower and are the ones we used for our budget and we believe are some of the best options available. These suggested parts are high quality but cheap in price comparatively. The links to all of the parts will be provided in Appendix G.

8.3.1: Propane Heater

The propane heater we found, and believe would work well for our outdoor shower design, is a Camplux tankless propane heater. The temperature of the water can reach 115°F in just 20 seconds and pumps water out at 1.58 gallons per minute. This will provide the desired water pressure and temperature so the user will be comfortable in the outdoor shower (Plumbing Lab, 2020).



Figure 29: Propane heater

8.3.2: Drainage rock

We recommend getting the drainage rock from Bond Sand and Gravel, as Lisa Burris has used products from them in the past. We calculated that 2.5 cubic yards of drainage rock will be needed for the dry well of the outdoor shower.



Figure 30: Drainage rock

8.3.3: Miscellaneous

We recommend using Lowe's or Home Depot for the rest of the materials and hardware needed to build the outdoor shower. Most of the hardware and materials needed are relatively cheap and are similar in price regardless of the supplier. For the boards we suggest using a local lumber yard because they will likely be cheaper than using Lowe's or Home Depot. All of our prices are estimates from Lowe's, as we could not gather prices from lumber yards due to COVID-19.

9.0 Conclusion

Due to the COVID-19 pandemic, we unfortunately could not build the outdoor shower we designed for Turn Back Time. We did, however, achieve our goal of designing a sustainable outdoor shower for Turn Back Time Farm that can be used by future WPI students, youth of TBT, and adults who visit the farm. We developed a design that fills not only the wants and needs of Turn Back Time, but also the people who will choose to visit TBT for the day or overnight stays. We also provided detailed instructions for whomever decides to build this shower in the future.

With a new outdoor shower, Turn Back Time will have an additional facility for use by farm visitors. When visitors come to the farm, they will have the opportunity to take a shower in nature, while still feeling a sense of privacy. TBT is unique in the way that they will be providing the opportunity to use an outdoor shower at their farm. Many farms and nature education centers in the area do not offer this opportunity. This outdoor shower is an asset for the farm that will attract people for many activities, including adults for wellness retreats and WPI students who want to do a local off-campus IQP. The shower also expands upon the overnight capabilities of TBT, creating a private space for an individual to enjoy nature while bathing. Also, with the educational curriculum we designed, the shower supports the farm's mission of teaching students through nature, and showing them all the valuable things nature has to offer. Our group truly enjoyed working with Turn Back Time Farm. The experience allowed for us to learn about teamwork, sustainability, design methods, construction, and the importance of working and learning in nature. We understand that Turn Back Time plans to construct the outdoor shower using our plans later this summer. We are eager to keep in touch with Lisa Burris to learn about the benefits and limitations of the shower and the curriculum for TBT's stakeholders and community members.

References

- Adams, W. (2015). *Conducting semi-structured interviews* doi:10.1002/9781119171386.ch19
- Amazon.com : Flexible flyer 3-pack snow saucer sleds. (n.d.). Retrieved from https://www.amazon.com/Flexible-Flyer-626-Flying-Saucer/dp/B001NDIZIM/ref=sr_1_4?dchild=1&keywords=plastic+sled&qid=1588949261&sr=8-4
- Beiles, N. (2008). Outdoor showers. Retrieved from <https://www.thisoldhouse.com/yards/21015436/outdoor-showers>
- Bob Vila. (2016). Dry wells. Retrieved from <https://www.bobvila.com/articles/dry-wells-101/>
- Chintis, Cady. (2015) Shou Sugi Ban. Retrieved from <https://www.wc-studio.com/journal/shou-sugi-ban>.
- Cape Cod Shower Kits Co.Outdoor showers designs enclosures. Retrieved from <https://capecodshowerkits.com/outdoor-showers-designs-enclosure-ideas/>
- Chawla, L. (2015). Benefits of nature contact for children. *Journal of Planning Literature*, 30(4), 433-452. doi:10.1177/0885412215595441
- Contract Environments. (2014). Acoustical privacy - what's that mean. Retrieved from <http://www.contractenvironments.us/uncategorized/acoustical-privacy-whats-that-mean/>
- CraftJack. (2018). 2020 dry well costs | dry well installation cost. Retrieved from improvenet.com/r/costs-and-prices/dry-well-installation-cost
- Dalahmeh, S. S., Pell, M., Vinnerås, B., Hylander, L. D., Öborn, I., & Jönsson, H. (2012). Efficiency of bark, activated charcoal, foam and sand filters in reducing pollutants from greywater. *Water, Air, & Soil Pollution*, 223(7), 3657-3671.
- Dans le Lakehouse. (2018). Siding Material Pros & Cons. Retrieved from <https://www.danslelakehouse.com/2018/05/siding-material-pros-cons.html>
- Delaware Health and Social Services. (2013). Arsenic. Retrieved from <https://www.dhss.delaware.gov/>
- Department of Communication, Climate action and Environment. (2020). Causes and greenhouse effect. Retrieved from <https://www.gsi.ie/en-ie/geoscience-topics/climate-change/Pages/Causes-and-the-greenhouse-effect.aspx>
- DuraLife Decking. (2020). Home. Retrieved from <https://duralifedecking.com/>
- Eco Wood Treatment.Eco wood treatment. Retrieved from ecowoodtreatment.com

Elmitwalli, T., & Otterpohl, R. (2011). Grey water treatment in upflow anaerobic sludge blanket (UASB) reactor at different temperatures. *64*(3), 610-617. doi:10.2166/wst.2011.616

Environmental Nature Center. (2017). Benefits of learning in nature. Retrieved from <https://www.encenter.org/blog/benefits-of-learning-in-nature/>

Esen, M., & Esen, H. (2005). Experimental investigation of a two-phase closed thermosyphon solar water heater. *Solar Energy*, *79*(5), 459-468. doi:10.1016/j.solener.2005.01.001

Exploring your mind. (2019, Aug 18,). Aesthetic emotions: The emotional effect of beauty. Retrieved from <https://exploringyourmind.com/aesthetic-emotions-the-emotional-effect-of-beauty/>

Faunce, T. (2016). Eco wood treatment. US Builders Review, Retrieved from <https://www.usbuildersreview.com/case-studies/eco-wood-treatment/>

Friedler, E. (2004). Quality of individual domestic greywater streams and its implication for on-site treatment and reuse possibilities. *Environmental Technology*, *25*(9), 997-1008. doi:10.1080/09593330.2004.9619393

Hall, J. (2018). Gardenista: Outdoor showers. Retrieved from <https://www.gardenista.com/posts/hardscaping-101-outdoor-showers/>

Home Design Lover. (2015). 10 reasons why you should add an outdoor shower in your home. Retrieved from <https://homedesignlover.com/home-design/purpose-outdoor-shower/>

Home Water Works. (2011). Showering to saving. Retrieved from <https://www.home-water-works.org/indoor-use/showers>

Houseweather. (2020). 6 best portable water heaters. Retrieved from <https://houseweather.org/best-portable-water-heater/>

Jaffe, E. (2013). Why our brains love curvy architecture. Retrieved from <https://www.fastcompany.com/3020075/why-our-brains-love-curvy-architecture>

Jodie. (2019, Sep. 11,). What makes something aesthetically pleasing? Retrieved from <https://www.simpleminded.life/what-makes-aesthetically-pleasing/>

John Riha. (2011). How to install a french drain. Retrieved from <https://www.houselogic.com/organize-maintain/home-maintenance-tips/diy-french-drain/>

Jonathon Engels. (2017). How to make a hot water heater with compost. Retrieved from <https://www.onegreenplanet.org/lifestyle/hot-water-heater-with-compost/>

Kellert, S. R. (1998). A national study of outdoor wilderness experience. .

- Kuh, George, D. (2014). High-impact educational practices. Retrieved from <https://www.aacu.org/node/4084>
- Kuo, M., Barnes, M., & Jordan, C. (2019). Do experiences with nature promote learning? *Frontiers in Psychology, 10*, 305. doi:10.3389/fpsyg.2019.00305
- Last S. (2019). 7.7 writing instructions. In: Technical writing essentials. University of Victoria; Retrieved from <https://pressbooks.bccampus.ca/technicalwriting/chapter/writinginstructions/>.
- Lebow, S. (1996). Leaching of wood preservative components and their mobility in the environment : Summary of pertinent literature. (General Technical Report FPL ; GTR-93):36 P. ; 28 Cm., 93 doi:10.2737/FPL-GTR-93
- Lima, M. (2017). Why do we find circles so beautiful? Retrieved from <https://www.sciencefocus.com/science/why-do-we-find-circles-so-beautiful/>
- Lindsey, R. (2009). Incoming sunlight. Retrieved from <https://earthobservatory.nasa.gov/features/EnergyBalance/page1.php>
- Li, Z., Boyle, F., & Reynolds, A. (2010). *Rainwater harvesting and greywater treatment systems for domestic application in ireland* doi:<https://doi.org/10.1016/j.desal.2010.05.035>
- Lowe's Home Improvement. (2020). Lowe's home improvement. Retrieved from <https://www.lowes.com/>
- Massachusetts Department of Elementary and Secondary Education. (2016). 2016 massachusetts science and technology/engineering curriculum framework. Retrieved from <http://www.doe.mass.edu/frameworks/scitech/2016-04.pdf>
- Meier, E. (2020). The Wood Database. Retrieved from <https://www.wood-database.com/>
- Natural Handyman. Linseed oil - its uses and limitations. Retrieved from <https://www.naturalhandyman.com/iip/infpai/inflin.html>
- Northern Lights Solar Heating. (n.d.). Sunrain solar flat plate collector. Retrieved from https://nlsolarheating.solartubs.com/sunrain-solar-flat-plate-collector-srcc-solar-water-heater-p-296.html?gclid=CjwKCAjwkun1BRAIEiwA2mJRWWzPQLw80sTsJkMhfop9iOrRBNMrqOd7e8cF3YyZClmw8rUg3DQj6hoC-asQAvD_BwE
- Nukmal, N., Umar, S., Kanedi, M., & Amanda, S. P. (2017). Effect of styrofoam waste feeds on the growth, development and fecundity of mealworms. *Online Journal of Biological Sciences*, doi:10.3844/ojbsci.2018.24.28

- OARS Companies Inc. (2018). *5 of the Best Eco-Friendly Soaps*. OARS Companies Inc. <https://www.oars.com/blog/5-best-eco-friendly-soaps/>
- Outdoor Shower Company. (2020). Types of outdoor shower drainage. Retrieved from <https://www.outdoorshowerco.com/know-the-types-of-outdoor-shower-drainage/>
- Paxton, M. A. (2017). Water rates, paxton MA. Retrieved from <https://www.townofpaxton.net/index.asp?SEC=06E9689F-BF8A-4F7A-81E9-034E27746D58&DE=E15C8839-18D5-40D6-B164-38BCC170222E>
- PBS LearningMedia. (2020). The sun and the water cycle. Retrieved from <https://www.pbslearningmedia.org/resource/buac35-sci-sunwatercycle/the-sun-and-the-water-cycle/>
- Plum Creek Conservation District. (2006). Rainwater collection and conservation. Retrieved from <http://pccd.org/rainwc.htm>
- Plumbing Lab. (2020). How portable water heaters work. Retrieved from <https://plumbinglab.com/portable-camping-hot-water-heater/>
- Roberts, T. (2017). How to make a compost water heater. Retrieved from <https://permaculturenews.org/2017/07/19/make-compost-water-heater/>
- Robolabz. (2016). Water cycle in a zip lock bag. Retrieved from <http://robolabz.org/water-cycle-in-a-zip-lock-bag/>
- Ross, R. (2018). The science behind composting. Retrieved from <https://www.livescience.com/63559-composting.html>
- Santos, C., Taveira-Pinto, F., Cheng, C. Y., & Leite, D. (2012). Development of an experimental system for greywater reuse. *Desalination*, 285, 301-305. doi:<https://doi-org.ezpxy-web-p-u01.wpi.edu/10.1016/j.desal.2011.10.017>
- Schlemmer, D., Sales, M. J. A., & Resck, I. S. (2009). *Degradation of different polystyrene/thermoplastic starch blends buried in soil*
doi:<https://doi.org/10.1016/j.carbpol.2008.06.010>
- Sea To Summit. (n.d.). Wilderness Wash Biodegradable Soap. <https://seatosummitusa.com/products/wilderness-wash>
- Shahe. (2015, -03-19T13:47:06+00:00). Eco wood treatment: Definition, benefits and usage. Retrieved from <https://civilengineersforum.com/eco-wood-treatment-details/>

Shizenstyle. (2019). The complete guide to yakisugi (shou sugi ban). Retrieved from <https://shizenstyle.com/the-complete-guide-to-yakisugi-shou-sugi-ban/>

Southface Energy Institute. (2004). Using the sun to heat water. Retrieved from <http://www.solaripedia.com/files/274>

Smith, B. (2020). What effects does propane have on the environment? Retrieved from <https://education.seattlepi.com/effects-propane-environment-5050.html>

Steelcase Research. (2016, Nov 28,). Reinventing what privacy means. Retrieved from <https://architecturenow.co.nz/articles/reinventing-what-privacy-means/>

Strife, S., & Downey, L. (2009). Childhood development and access to nature., 99-122. doi:10.1177/1086026609333340

Surfrider Foundation. (2020). Rainwater harvesting. Retrieved from <https://www.surfrider.org/coastal-blog/entry/calculate-rainwater-harvesting-potential-area-needed-to-absorb-it>

The Balance Small Business. (2020). What is a market research focus group? Retrieved from <https://www.thebalancesmb.com/what-is-a-market-research-focus-group-2296907>

The City of Portland. (n.d.). Rainwater resources | green building | the city of portland, oregon. Retrieved from <https://www.portlandoregon.gov/water/article/444419>

Travis, M. J., Wiel-Shafran, A., Weisbrod, N., Adar, E., & Gross, A. (2010). Greywater reuse for irrigation: Effect on soil properties. *Science of the Total Environment*, 408(12), 2501-2508. doi:<https://doi.org/10.1016/j.scitotenv.2010.03.005>

Turn Back Time. (2019). Who are we. Retrieved from <https://tbtinc.org/mission/>

Urbanline Architectural. (2018). Hardwood vs softwood: Pros, Cons & Best Uses. *Urbanline Architectural*. Retrieved from <https://www.urbanline.com.au/hardwood-vs-softwood-pros-cons-best-uses/>

USDA - natural resources conservation service. (n.d.). Retrieved from <https://www.nrcs.usda.gov/wps/portal/nrcs/site/national/home/>

Vermont Studios.Linseed oil. Retrieved from <https://vermontwoodsstudios.com/content/linseed-oil>

Waste water recycling: Fresh solutions. (2020). Retrieved from <https://www.pbslearningmedia.org/resource/waste-water-recycling/flipside-science-fresh-solutions-video/>

- Weather underground weather history. Retrieved from <https://www.wunderground.com/history/daily/us/ma/paxton/KORH>
- Weisz, E., & Zaki, J. (2017). Empathy-building interventions: A review of existing work and suggestions for future directions. *The Oxford Handbook of Compassion Science*, doi:10.1093/oxfordhb/9780190464684.013.16
- Aqua-Bright Irrigation and Illumination. (2018). *What Are The Benefits Of A Dry Well Drainage System?* Aqua-Bright Irrigation and Illumination. <https://www.aquabrightllc.com/drainage-systems-baltimore/benefits-dry-well-drainage-system/>
- Wilson, R. A. (1994). Integrating outdoor/environmental education into the special education curriculum. *Journal of Special Education*, 29(3), 156-159. doi:10.1177/105345129402900305
- WOOD Magazine (n.d.). 9 Mighty Woods For Outdoor Projects. Retrieved from <https://www.woodmagazine.com/materials-guide/lumber/outdoor-lumber>.
- Woodwork Details. (a). Linseed oil as a woodworking finish. Retrieved from <http://www.woodworkdetails.com/knowledge/finishing/linseed-oil>
- Woodwork Details. (b). Tung oil as a woodworking finish. Retrieved from <http://www.woodworkdetails.com/knowledge/finishing/tung-oil>
- WPI. (n.d.). Project-based learning. Retrieved from <https://www.wpi.edu/project-based-learning>
- Wurochekke, A. A., Mohamed, R., Al-Gheethi, A. A., Atiku, H., Amir, H. M., & Matias-Peralta, H. M. (2016). Household greywater treatment methods using natural materials and their hybrid system. *Journal of Water and Health*, 14(6), 914-928. doi:rg/10.2166/wh.2016.054

Appendix A: Turn Back Time Interview Questions

1. What is the location of the shower on the farm?
2. What is the budget to build the shower?
3. Who will be using the shower?
4. What will the water source be?
5. How will the water be heated?
6. Any building codes to worry about?
7. Will there be a changing stall attached to it?
8. Are there any specific wants of the grey water from the shower?

Appendix B: Survey Questions for Potential Shower Users

The link below is the link to the survey, where the questions are presented in the form that they were sent out.

<https://forms.gle/rjWBftom1tcoUiUY6>

Appendix C: Materials List

Materials	Quantity
Propane Water Heater	1
Irrigation Hose	300 feet
Shower head	1
Copper Piping	About 40 feet
Shower curtain rod	1
Shower curtain	1
Cement 75lbs	1
1"x6" cedar boards 8'	77
4"x4" pressure-treated boards 12'	8
2"x4" cedar boards 8'	28
4'x8' Pre-Made Lattice	2
Screws and Nails	About 500
Lock for door	1
Door hinges	2
Drainage rock	2.5 cubic yards
Hooks	2 (if desired)
Mirror	1 (if desired)
Pipe Straps	20
Shower Handle	1
Sharkbite ½ inch pipe fittings	15
Pipe Cutter	1

Appendix D: Instructions for Building the Shower Structure

Shower Structure Materials	Count
Cedar Boards 1x6-8'	76
Cedar Boards 2x4-8'	32
Pressure-Treated 4x4-12'	7
2.5" Wood Screws	about 500
Drainage Rock	2.5 cubic yard
Cement	75lb
Door Lock	1
Door Hinges	2
Propane Water Heater	1
Copper Piping	About 30ft
Sharkbite Pipe Fittings ½ inch	About 15
Pipe Cutter	1
Pipe Straps	20
Irrigation Hose	About 300 ft
Hose Splitter	1
Shower Handle	1

Cut List and Board Reference Numbers

Refer to this list of wood when finding the correct piece of wood that corresponds to the board number in the chart below.

Board Number	Item to be Cut	Cut Dimensions	Number to be Cut
1	1"x6" Cedar Board	Cut to 7' Long	54
2	1"x6" Cedar Board	80" Long	6
3	1"x6" Cedar Board	5' Long	17
4	2"x4" Cedar Board	4' 1.5" Long	12
5	2"x4" Cedar Board	66" Long	3
6	2"x4" Cedar Board	33" Long	3
7	2"x4" Cedar Board	27.5" Long	3
8	2"x4" Cedar Board	Purchased at 8' in length. Should not be cut	3
9	4"x4" Pressure Treated Posts	Purchased at 12' in length. Should not need to be cut	7
10	2"x4" Cedar Board (leftover)	1'-6" (Use leftover piece from the #4 board)	6
11	2"x4" Cedar Board (leftover)	1'-11.5" (Use leftover piece from the #4 board)	4
12	1x6" Cedar Board (leftover)	2' -9" (Use leftover piece from the #3 board)	3

Terminology

Front

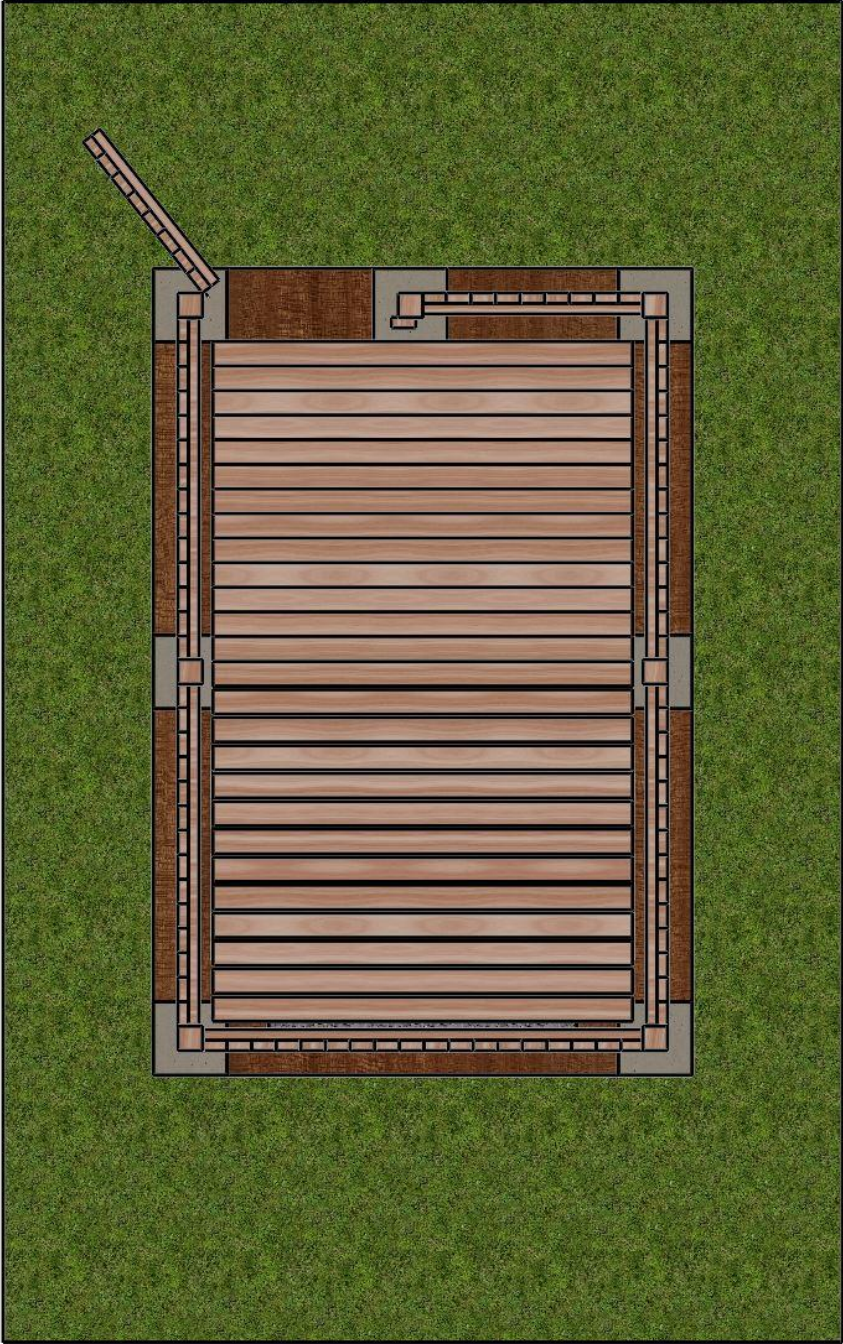

Left

Right

Back

1. Ground Leveling

Instructions:

1.1 Level an open area to the following dimensions below (9' - 8.5" x 6' - 8").

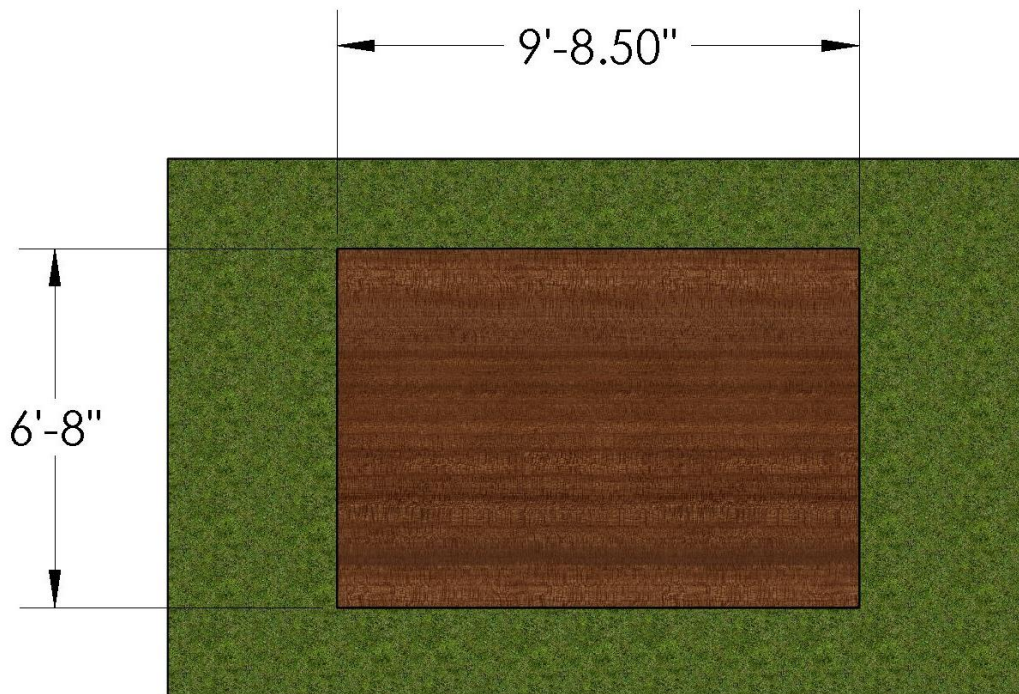

2. Digging

Materials Needed:

- Shovel
- Tape Measure
- Level

Instructions:

2.1 Dig 10.5" x 10.5" holes that are 4' - 6" deep in the locations below

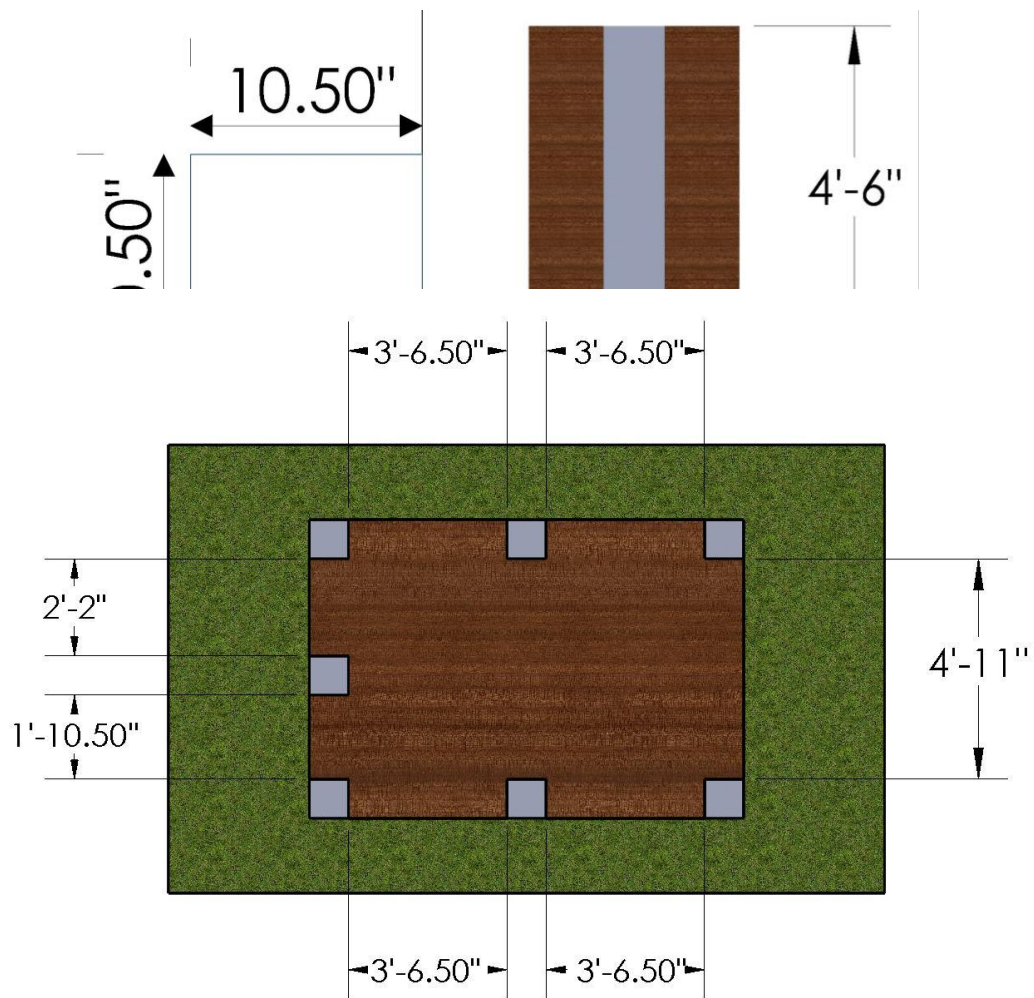

2.2 Fill each hole with 6" of drainage rock.

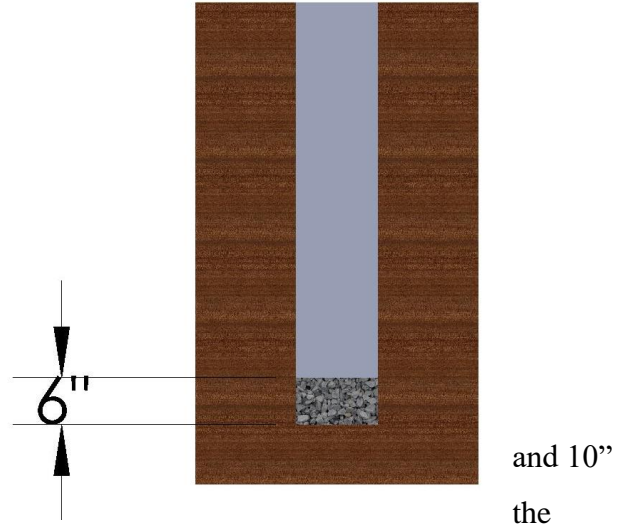

2.3 Dig a hole 6.5" from the back edge from the left and right side edges that is following dimensions:

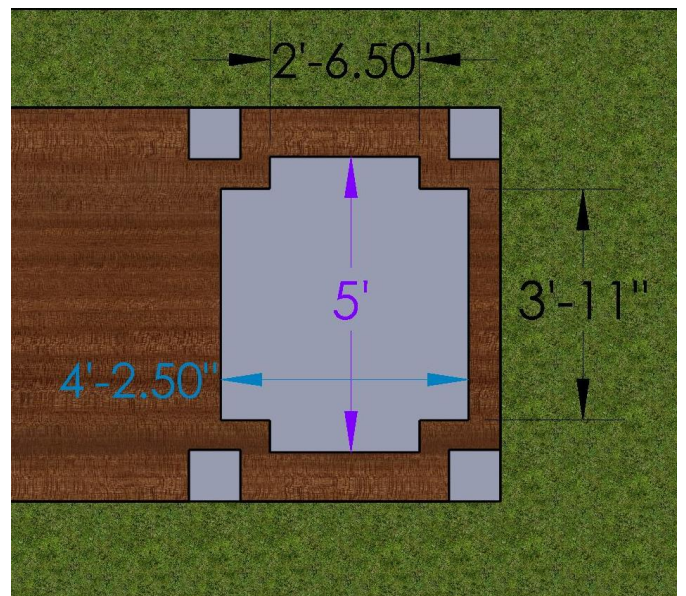
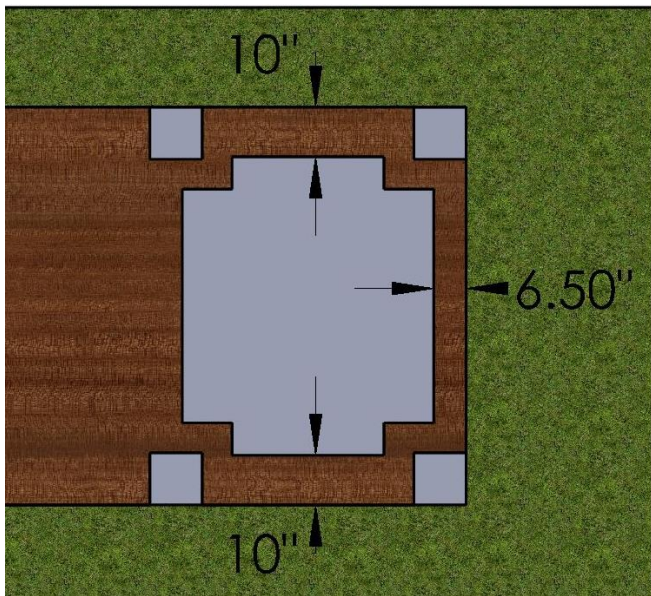

2.4 Ensure sure there is 6" of space between the holes on the edges and the center holes

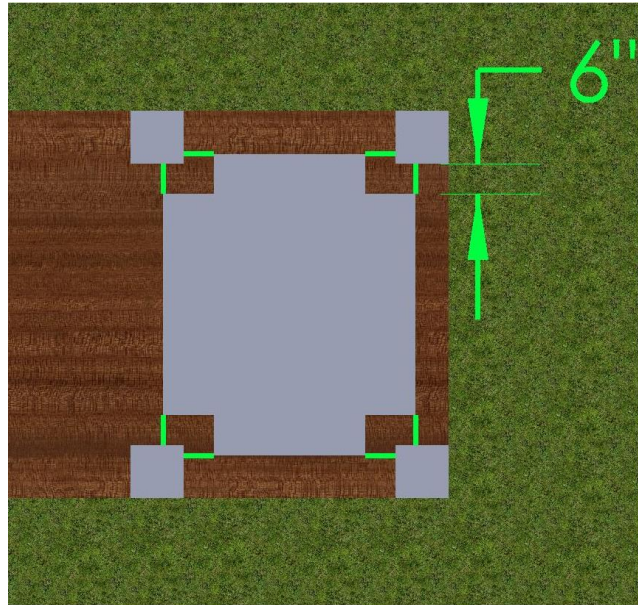

2.5 Dig the hole 3' deep and fill with the drainage rock



3. Posts

Materials needed:

- All seven #9 boards
- Cement
- Plumb Line
- Tape Measure

Instructions

3.1 Place the post (#9 boards) in the center of each of the holes so they are at the following distances (pictured below) apart.

Fill each hole with cement. Adjust the posts ensuring the posts are completely vertical using the plumb line. The plumb line is a weight with a string attached that makes sure that the posts are completely straight up and down.

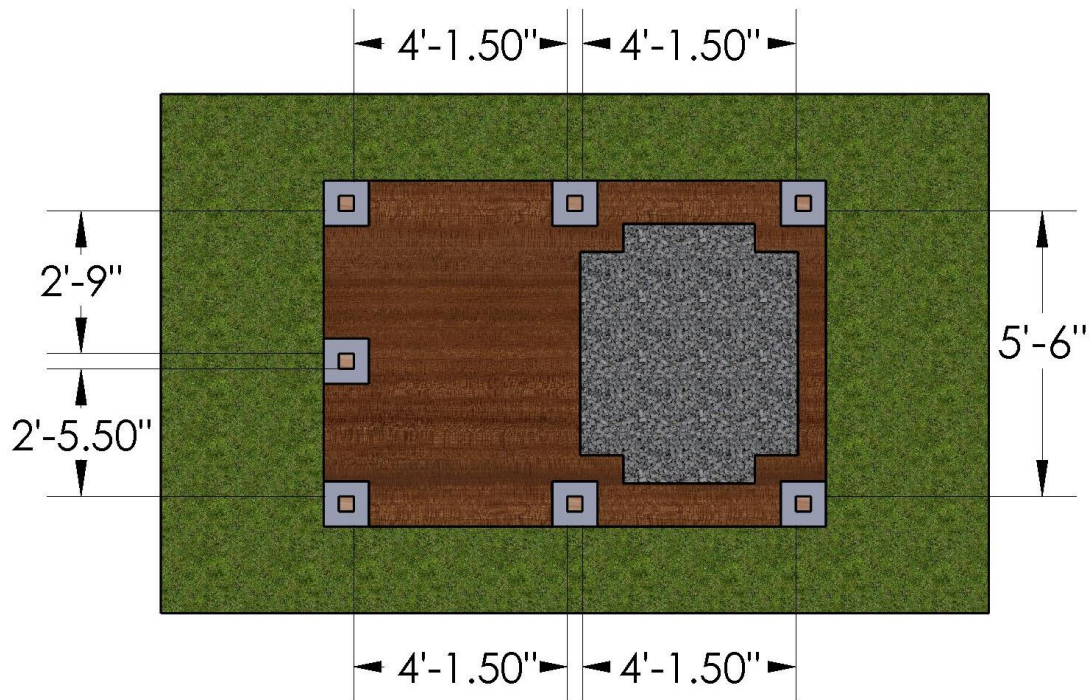

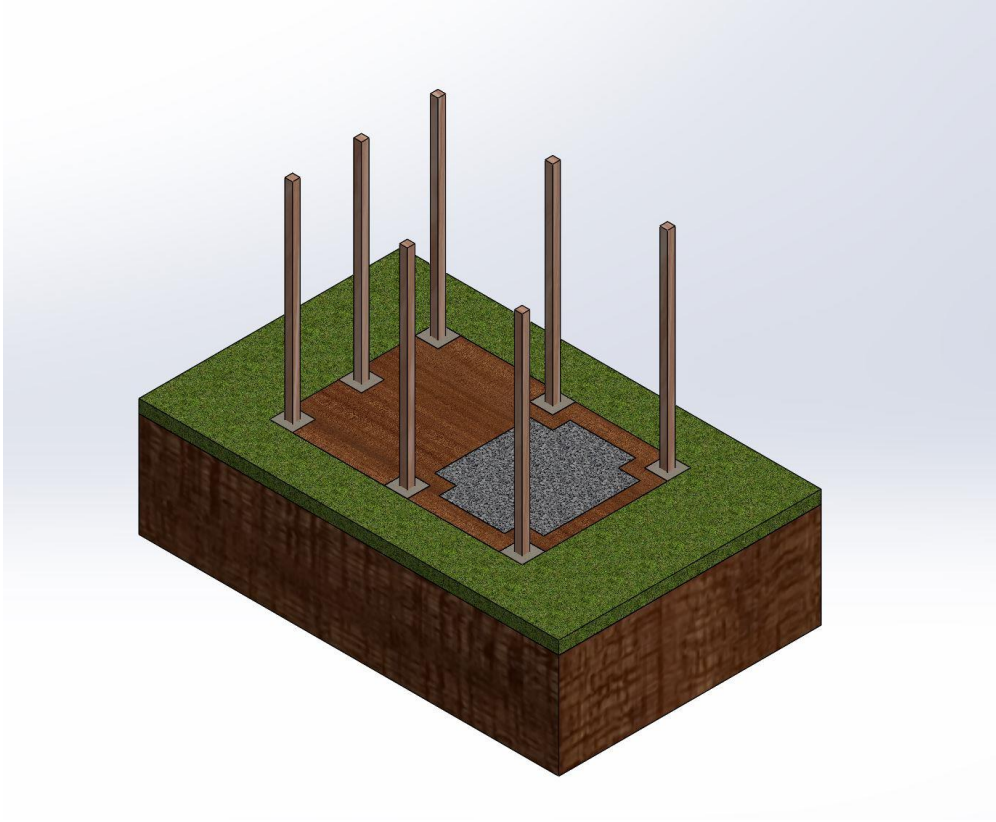

4. Flooring

Materials needed:

- All three #8 boards
- All 17 #3 boards
- Tape Measure
- Screws
- Drill

Instructions:

4.1 Place the #8 boards on their short edge and separate each one by 1' - 10.5"

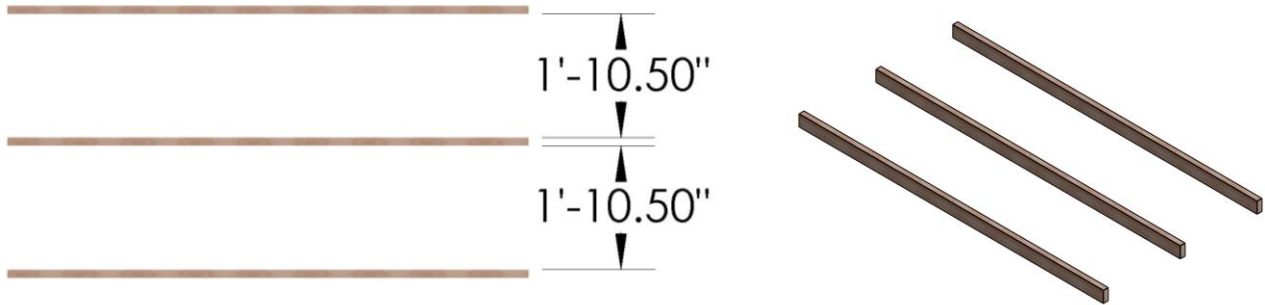

4.2 Place a #3 board on top of the three pieces of wood so that 5.25" of the 5' board hangs off from the top and bottom and 1" hangs off from the side and screw it in using 2 screws at the top and bottom and one in the middle.

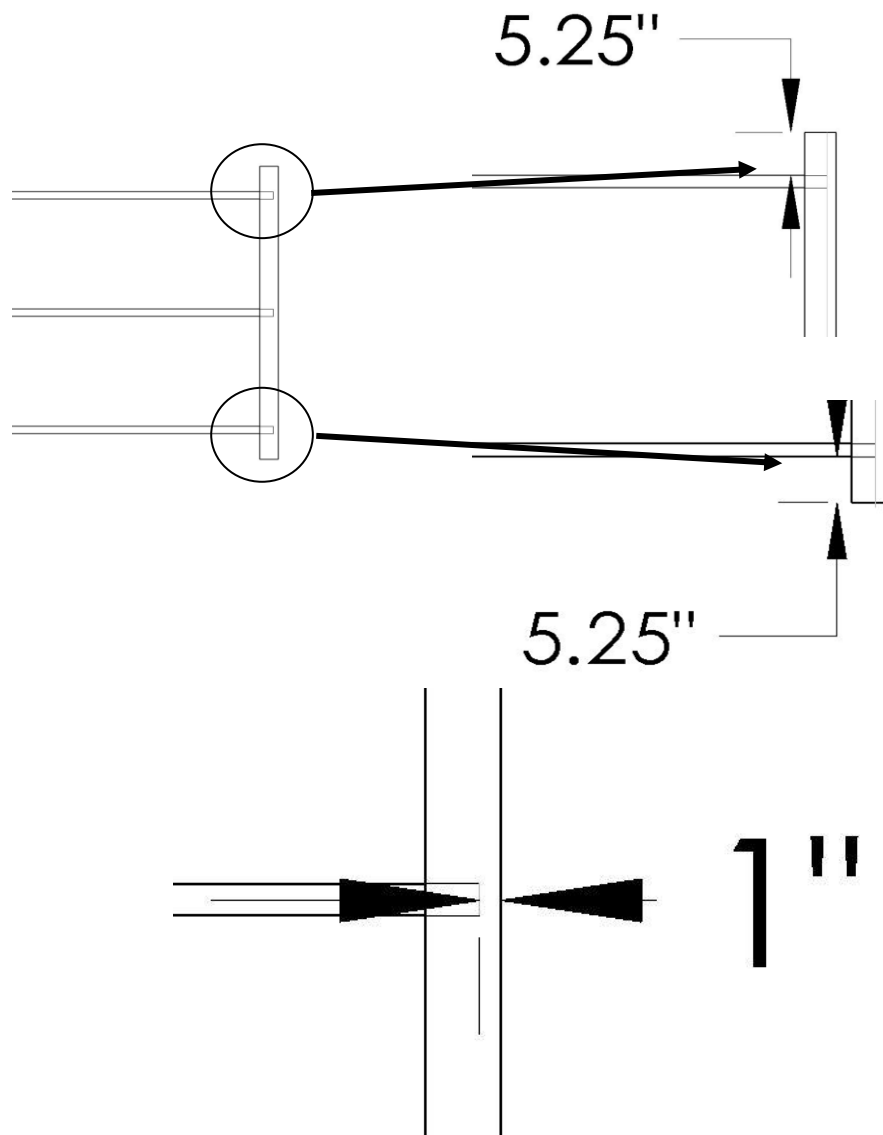

4.3 Place another 5' board .5" away from the previous board.

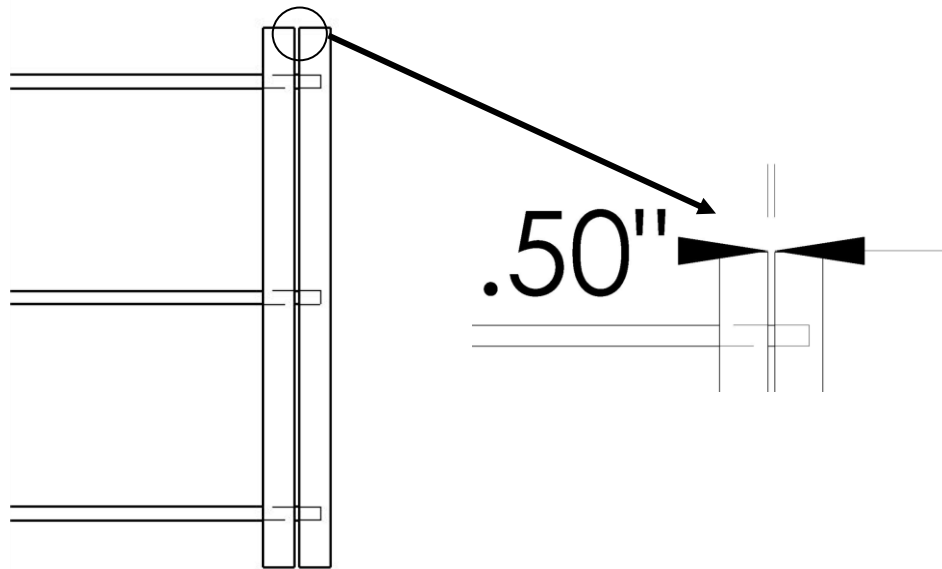

4.4 Keep on placing #3 boards .5" apart until 8 boards have been placed and screwed

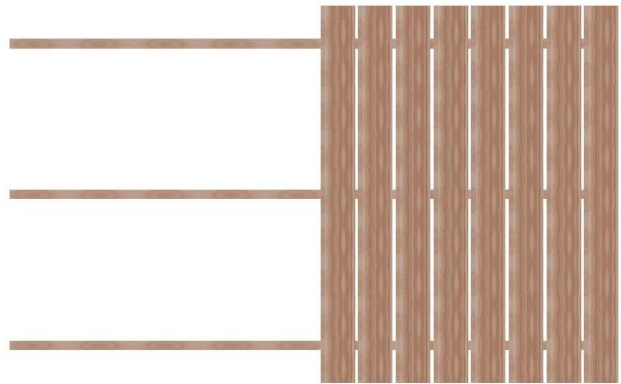

4.5 Place the next 9 #3 boards together so they are flush together and screw them in using two screws on the top and bottom and one in the center.

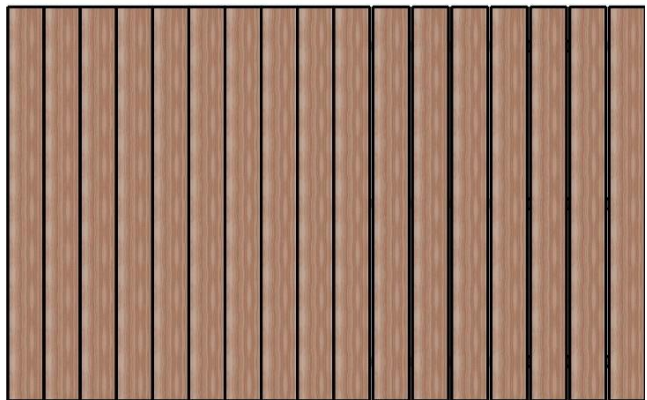



4.6 Place the constructed floor in the middle of the shower

5. Walls

Materials Needed:

- All 12 #4 Boards
- All 56 #1 Boards
- All 3 #5 Boards
- All 3 #7 Boards
- Screws
- Tape Measure
- Drill

Instructions:

Left and Right Wall

5.1 Place a #4 board 5" from the ground (short edge facing up) on both sides of the center post and offset it 1.25" from the inside part of the shower. Place two more boards, 2'-10.25" and 6' from the bottom board, on both sides of the center post.

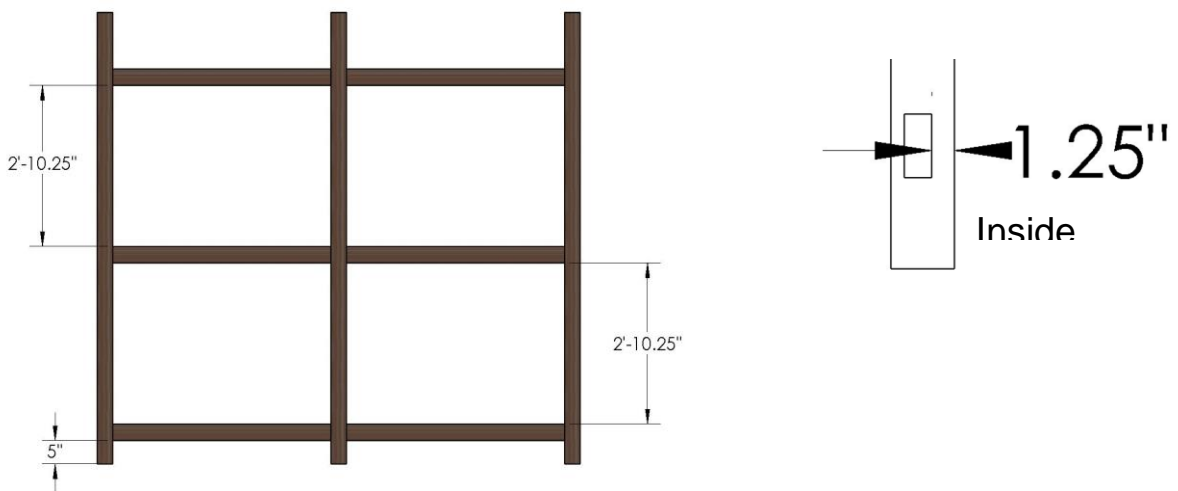

5.2 Connect the #1 boards (flush with the ground) to the frame allowing no space in between each board using 5 screws per board: two at the top and bottom and one in the center.

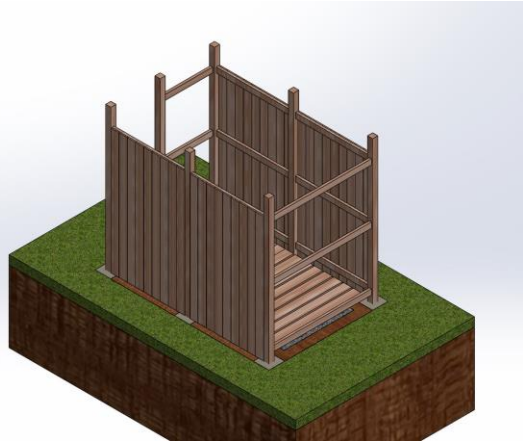
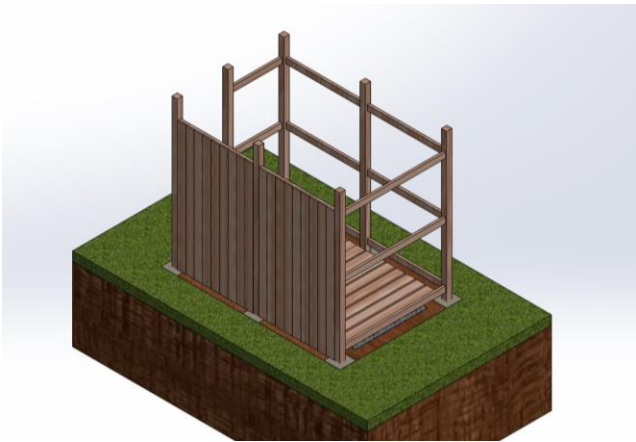
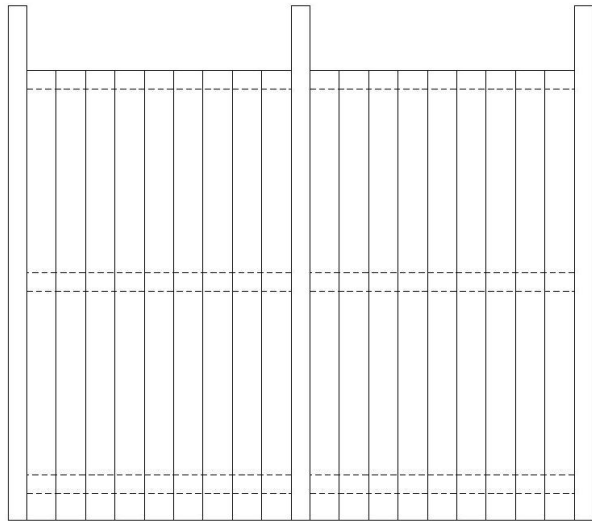

Back Wall

5.3 Place a #5 board 5" from the ground with the short edge facing up and offset it 1.25" from the inside part of the shower. Place two more boards, 2'-10.25" and 6' from the bottom board.

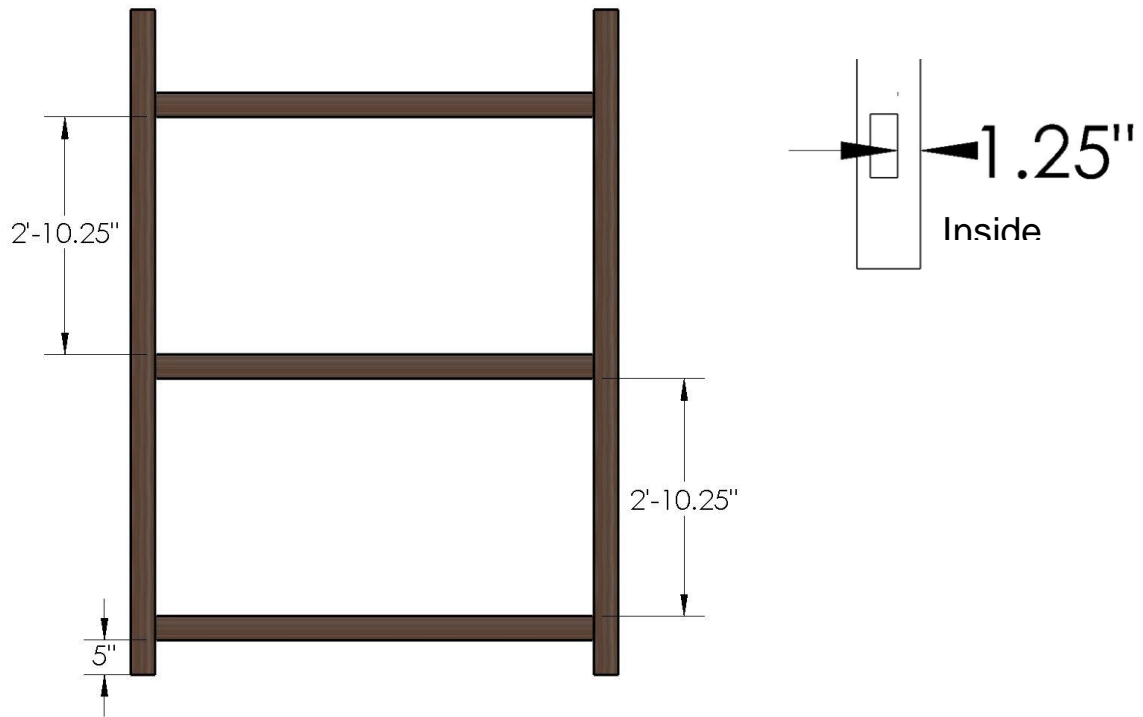

5.4 Connect 12 #1 boards (flush with the ground) to the frame allowing no space in between each board.

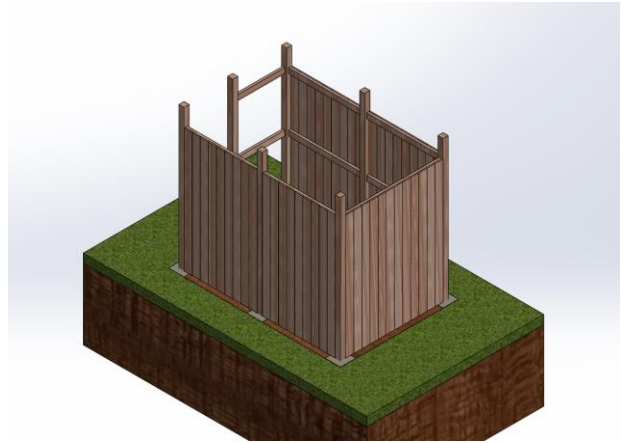
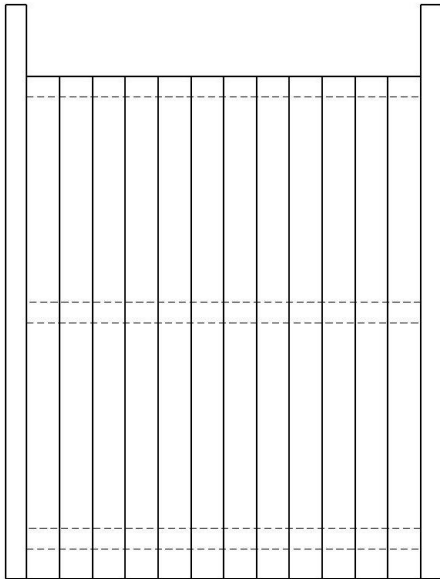

Front Wall

5.5 Place a #7 board 5" from the ground (short edge facing up) and offset it 1.25" from the inside part of the shower. Place two more boards, 2' - 10.25" and 6' from the bottom board.

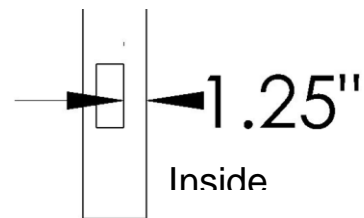
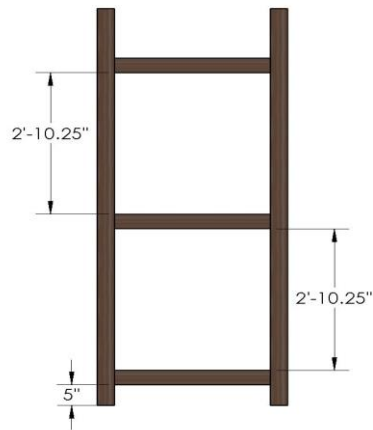

5.6 Connect 6 7' boards (#1) to the frame allowing no space in between each board and with the bottom edge flush with the ground.

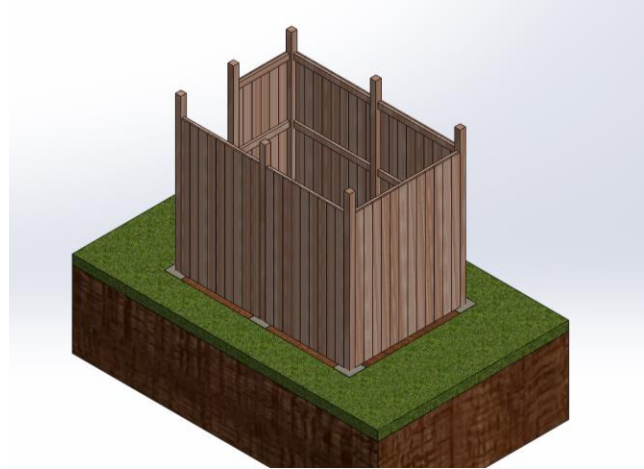
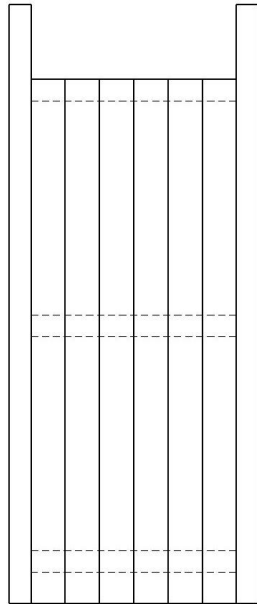

6. Door

Materials Needed:

- All Three #6 Boards
- Six #2 Boards
- Screws
- Hinges
- Lock

Instructions:

6.1 Place all the #2 boards together. Place the #6 boards flush with the top and another one flush with the bottom of the wood (with the short edge facing up). Screw them together. Screw the third 2"x 4" centered between the other 2.

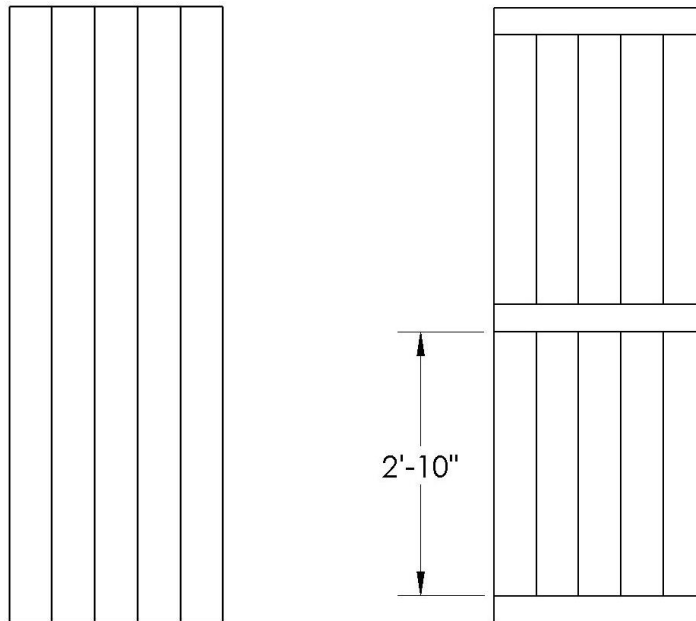

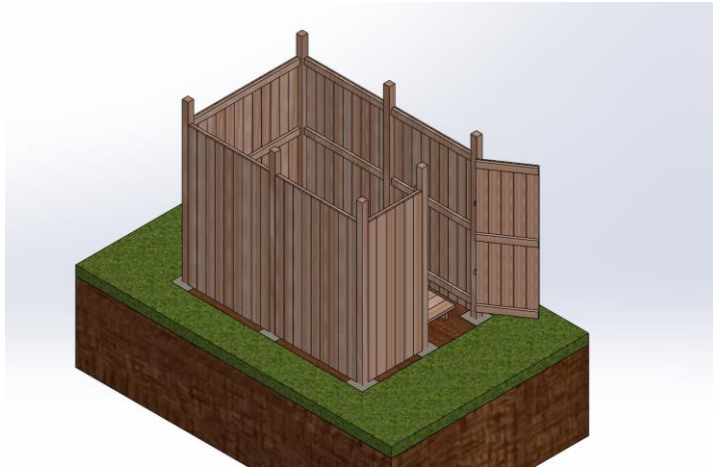

6.2 Connect the door to the front right post using the two hinges so that it opens outwards.

6.3 Using the wood screws attach the lock on the inside of the door on the middle 2"x4" and the middle post.

6.4 Screw the last #2 board to the front center post so that it hangs 2" from the post

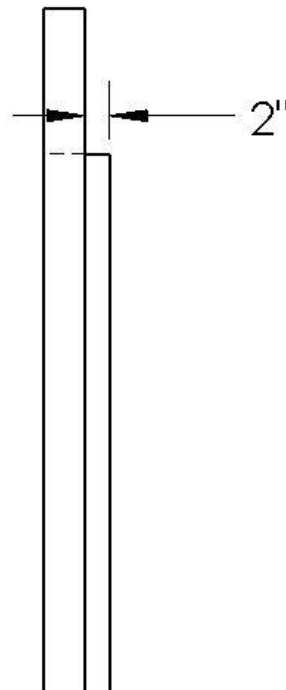

7.0 Curtain

7.1 Take the shower curtain and connect it to the shower curtain rings. Then place the shower curtain rings on the adjustable shower rod.

7.2 Place the adjustable shower rod at the top of the posts located in the center of the left and right walls of the shower.

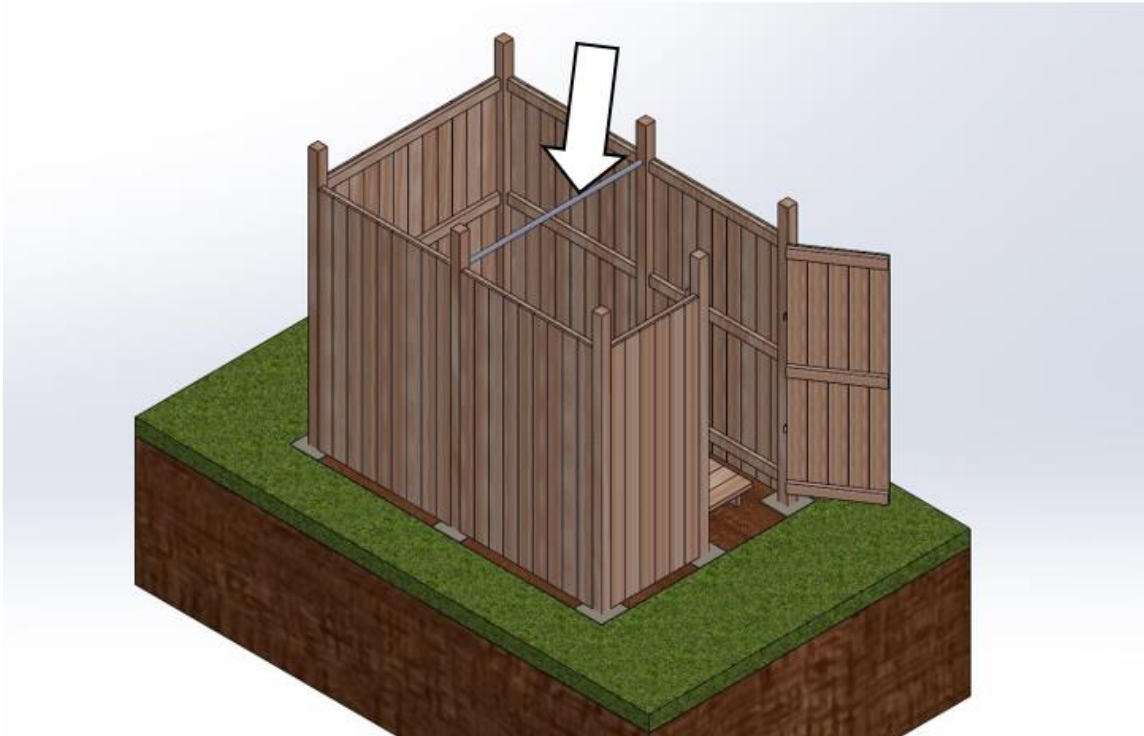

8.0 Bench

Materials Needed:

- All #10 boards
- All #11 boards
- All #12 boards
- Screws
- Drill

Instructions:

8.1 Place the legs (#10 boards) the following distances (picture below) apart with the long side sticking up.

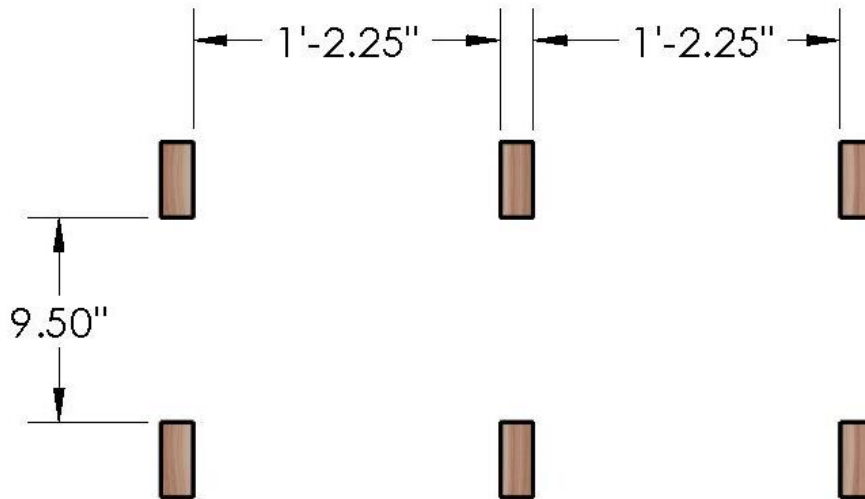

8.2 Screw the #11 boards to each pair of legs, with the center pair having 1 on both sides. Make sure the tops are flush with the #10 boards.

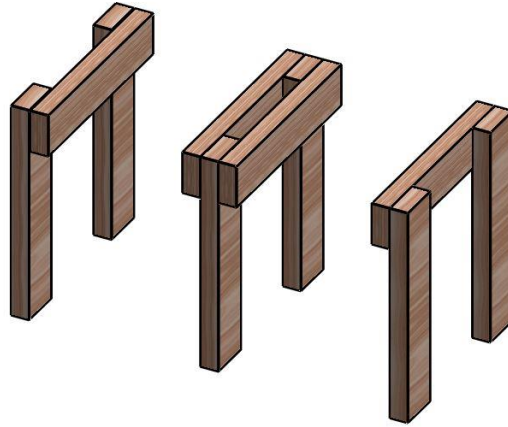

8.3 Screw the #12 boards on top with no space in between them.

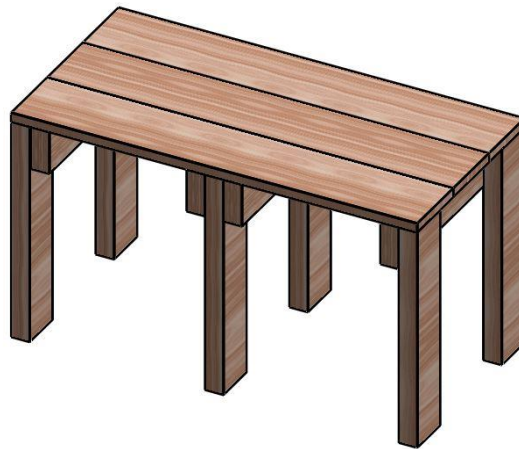

9.0 Treatment

To prevent the wood from rotting or fading, coat every surface of the wood with a non-toxic wood preservative, we suggest using Eco Wood Treatment, want to have an aged greyish look, or linseed or Tung oil. The Eco Wood treatment only needs one application while the linseed oil and Tung oil needs to be reapplied every 5-6 years.

10.0 Plumbing

Plumbing Materials	Count
Propane Water Heater	1
Copper Pipes	About 30ft
Pipe Fittings	About 15
Pipe Cutter	1
Pipe Straps	30
Irrigation Hose	About 200 ft
Hose splitter	1
Shower handle	1

For the plumbing, half-inch copper piping will be used for all permanent piping.

1. Place the propane water heater on the back wall of the shower.
2. Connect irrigation hoses to the tap water supply.
3. At the shower, connect the hose splitter to the other end of the irrigation hose.
4. From the hose splitter, run more irrigation hose to the water inlet on the propane water heater.
5. Attach copper piping to the hot water outlet on the water heater and run the piping through the back wall of the shower to the shower handle. This is the hot water source for the shower.
6. From the other end of the hose splitter, run more irrigation hose through the back wall of the shower and connect it to the hose-to-copper pipe adapter that is permanently attached to the inner side of the back wall. This provides the cold water for the shower.
7. As shown below, copper piping is permanently installed on the inner wall of the outdoor shower using pipe straps. This copper piping includes a shower handle that allows users to adjust the temperature of the water.
8. From the shower handle run copper piping up to the top of the wall and attach the shower head at the top of this pipe.

9. For copper piping connections use the SharkBite ½ inch connections. These are used for ease of removal of plumbing during the winter months.

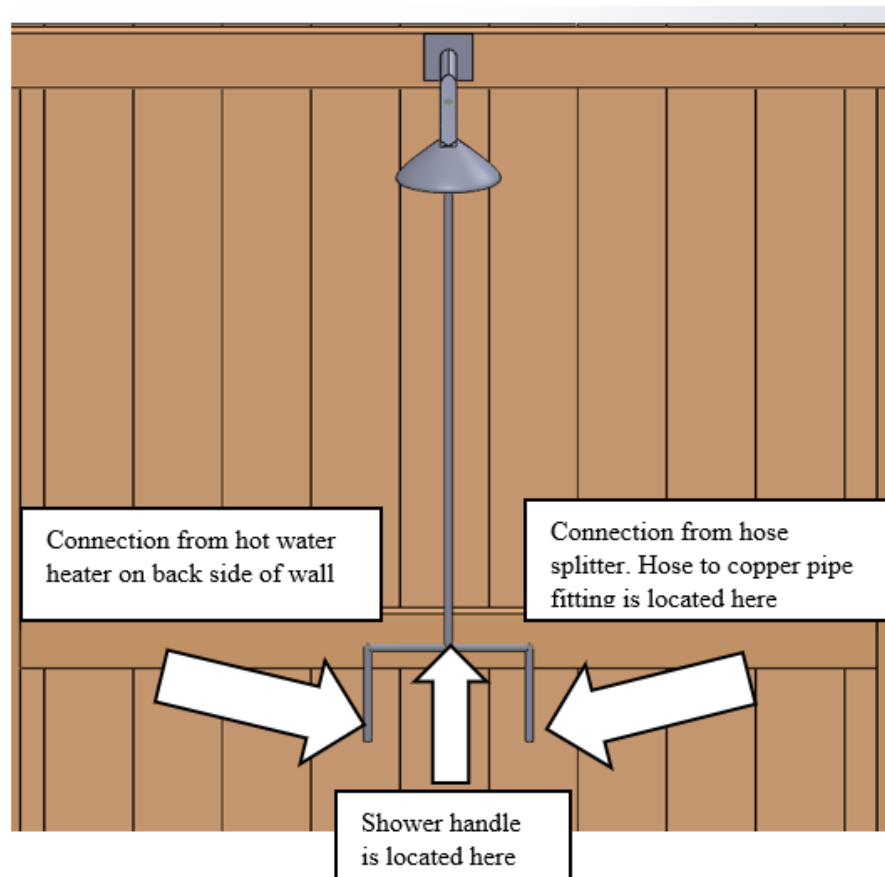

11.0 Miscellaneous

To create a soap holder for the shower, screw in a leftover piece of 2"x4" (preferably 4"-5") into the back wall, anywhere near the shower handle on the middle frame. The middle part of the 2"x4" can be sanded down .5" to prevent the soap from slipping off.

The last aspects of the shower to be added are the hooks and mirror. Add hooks to the inside of the shower as needed. We recommended that at least two are installed inside the shower and placed along the front wall. Additionally, we recommend installing a mirror on the inside edge of the door for users to have when changing. These add-ons are not necessary for the structure of the shower, however we recommend adding them for the ease of the user.

Appendix E: Lattice Structure Instructions

Tools:

- Drill
- Tape Measure
- Chop Saw/Table Saw/Hand Saw
- Level

Materials	Count
Pre-Built Pressure-Treated Garden Lattice 4'x8'	2
Screws	About 200
2"x4" Cedar Board	7

Cut List and Board Reference Numbers

Refer to this list of wood when finding the correct piece of wood that corresponds to the board number in the chart below.

Board Number	Item to be Cut	Cut Dimensions	Number to be Cut
1	2"x4" Cedar Board	4'-1.5" Long	4
2	2"x4" Cedar Board	5'-6" Long	1
3	2"x4" Cedar Board	2'-9" Long	1
4	2"x4" Cedar Board	2'-5.50" Long	1

Procedure:

1. Gather all materials
2. Cut all boards in the cut list
3. Place all boards in the locations specified in the picture below.

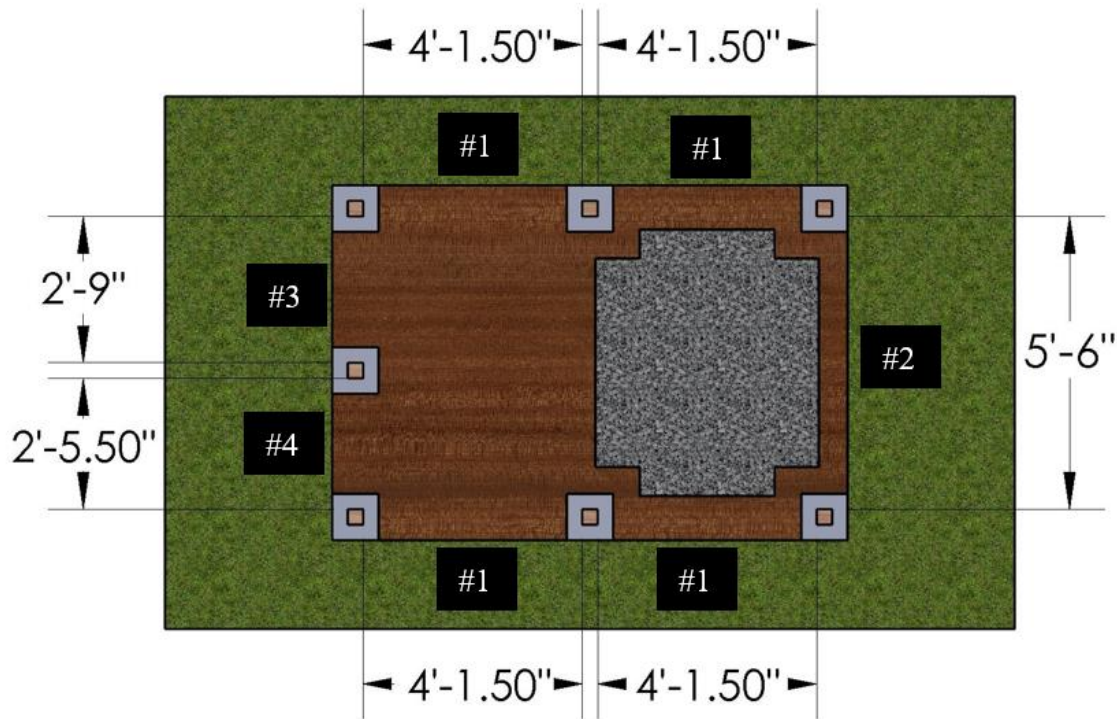

4. Screw in between the posts, flush with the inside edge of the posts and 10" above the existing wall. The 2" side of the board is facing up and they are placed according to the diagram above.
5. Cut each lattice piece into four 1'x8' sections, resulting in eight 1'x8' sections.
6. Then cut one section of lattice for each section (7 sections) of the shower to the lengths specified in the diagram above.
7. Then screw each lattice section flush with the inside edge of the 2"x4" board and in its corresponding section of the shower using the wood screws.

Appendix F: Rainwater Catchment Build Instructions

Materials	Count
55-Gallon Rainwater Barrel (with spout at bottom)	1
Irrigation Hose	10 feet
Large Funnel (We recommend using a large round plastic sled to gather the most rain)	1
Box Cutter	1
Plastic Weld Epoxy	1 Tube
Water Pump	1
Wire Mesh	4 square inches

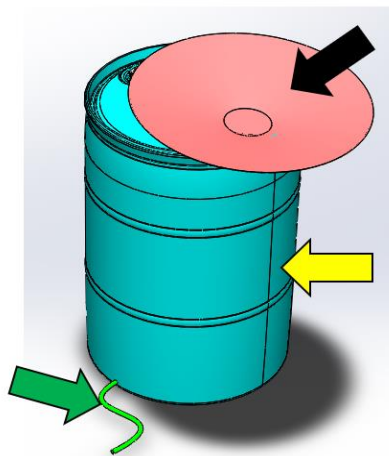

Color	Corresponding Part
Green	Irrigation hose that connects to shower
Yellow	55 gal. barrel
Black	26" Sled acting as funnel

1. Gather materials.
2. Place the rainwater barrel in the desired location.
3. Cut a hole in the bottom of the sled using the box cutters that corresponds to the size of

the hole in your 55-gallon barrel.

4. Place the wire mesh between the barrel opening and the sled opening.
5. Using the epoxy, attach the sled to the opening in the barrel with the mesh in between.
6. Connect the irrigation hose to the spout on the barrel.
7. Connect the water hose to the water pump.
8. From the water pump, run the irrigation hose to the shower and connect it at the hose splitter where the tap water would normally connect.

Appendix G: Suggested parts links

Propane Heater:

https://www.homedepot.com/p/CAMPLUX-ENJOY-OUTDOOR-LIFE-Camplux-Pro-6-l-1-58-GPM-Residential-Outdoor-Portable-Liquid-Propane-Gas-Tankless-Water-Heater-BD158N/313172227?mtc=Shopping-VF-F_D26P-G-D26P-26_10_WATER_HEATERS-MULTI-NA-Feed-PLA-NA-NA-WATER_HEATERS&cm_mmc=Shopping-VF-F_D26P-G-D26P-26_10_WATER_HEATERS-MULTI-NA-Feed-PLA-NA-NA-WATER_HEATERS-71700000033150351-58700003868932468-92700049173610559&gclid=Cj0KCQjwy6T1BRDXARIsAIqCTXoljFf49wBMV8fhh1PVOP4Z5Av8K91nNknY2oleDuCSQQ1LG9WURmQaAtfJEALw_wcB&gclsrc=aw.ds

Bond Sand and Gravel Drainage rock

<https://www.bondsandandgravel.com/products>

Wilderness Wash Biodegradable Soap

<https://seatosummitusa.com/products/wilderness-wash>