

# Telenursing RoboPuppet

A Major Qualifying Project in Partial Fulfillment of the Degree Requirements for the Bachelors of Science in Mechanical Engineering and Robotics Engineering at Worcester Polytechnic

Institute

Academic Year 2017-2018

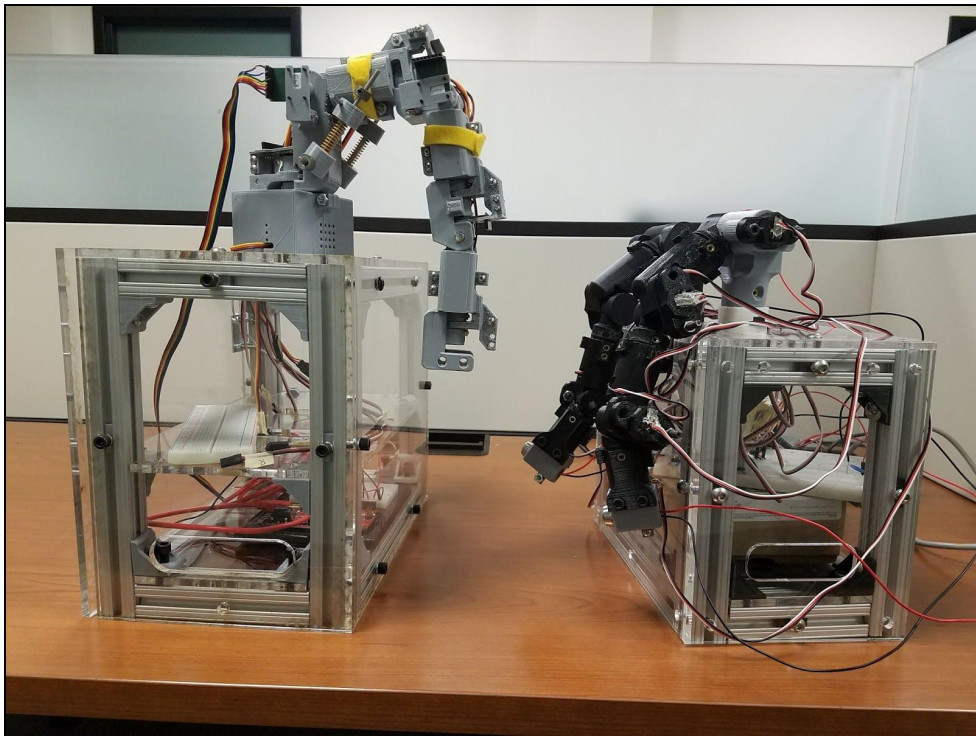

Brent M. Heavey	B.S. Robotics Engineering	Class of 2018
Matthew M. Lamare	B.S. Mechanical Engineering and Robotics Engineering	Class of 2018
Evan M. Stelly	B.S. Mechanical Engineering	Class of 2018

Advisor: Professor Zhi (Jane) Li

Submitted on April 26th, 2018

# Abstract

The Tele-robotic Intelligent Nursing Assistant (TRINA) is a retrofitted Rethink Robotics Baxter, designed to perform high strain, repetitive tasks for nurses and interact with infectious patients. Previously, it was found that these tasks were faster for nurses to perform by hand than to perform by using TRINA. One factor that increased the time needed to complete tasks was the lack of controller intuitiveness and difficulty of use, based on user feedback. The goal of this project is to improve TRINA's ability to perform common nursing tasks by designing an improved input device. The selected solution was to create a Robopuppet, a DH parameter scale model of Baxter's arms, with angle sensors. Based on a method created by researchers at Duke University, a Robopuppet allows for direct manipulation of Baxter's joint space with one-to-one correspondence. Actuators were integrated to provide the opportunity for gravity compensation and haptic feedback. The puppet was successful in manipulating Baxter's arms smoothly and precisely, however, more testing and refinement will be needed to more accurately perform complete nursing tasks with active feedback.

# Table of Contents

<b>Abstract</b>	<b>1</b>
<b>Table of Contents</b>	<b>2</b>
<b>Table of Figures</b>	<b>5</b>
<b>Acknowledgements</b>	<b>7</b>
<b>Executive summary</b>	<b>8</b>
Introduction	8
Background	9
Mechanical Design and Analysis	10
Electrical Design and Analysis	10
Control Software Design and Analysis	11
Results and Conclusions	12
<b>Introduction</b>	<b>14</b>
<b>Background</b>	<b>19</b>
Applications	19
Nursing	19
Other Potential Applications	21
Prior Work	22
Robotic Nursing	22
TRINA	23
RoboPuppet	27
Existing Input Devices	28
Puppets	28
Prior Technologies	29
Rethink Robotics Baxter	29
Mechanical Systems	31
Mechatronic Systems	33
Software Systems	36
<b>Mechanical Design and Analysis</b>	<b>38</b>
Duke Arm Design	38
Passive Robopuppet Redesign	41

Analysis of Passive Version	44
Active RoboPuppet Model	45
Actuator Selection	46
Preliminary Hand Design	49
Button Design	50
Manufacturing	51
<b>Electrical Engineering Design and Analysis</b>	<b>55</b>
Arm Angle Sensing	55
Passive RoboPuppet Arm Angle Sensing	55
Active Puppet Arm Angle Sensing	60
Actuator Signal Driving	64
Supply Rail	64
Microcontroller Signal	65
Wiring and Wire Management	66
Microcontroller Selection	68
Dead Man Switch	70
<b>Software and Control Design and Analysis</b>	<b>71</b>
High Level Overview	71
Passive RoboPuppet Software Architecture	72
Active RoboPuppet Software Architecture	73
Gravity Compensation Controller Policy	74
Haptic Control Scheme	75
<b>Conclusions</b>	<b>77</b>
Testing	77
Performance	78
Durability and Reliability	78
Cost	79
Continuation	79
<b>References</b>	<b>81</b>
<b>Appendix I: Troubleshooting Guide</b>	<b>83</b>
<b>Appendix II: Bringup Instructions</b>	<b>85</b>
For Simulated Robot:	85
For Physical Robot:	86
<b>Appendix III: CAD Models</b>	<b>87</b>

Passive RoboPuppet CAD Models	87
Active RoboPuppet CAD Models	89
<b>Appendix IV: Torque Calculations</b>	<b>93</b>

# Table of Figures

- 2.1: TRINA System from Duke University (Hauser et al, n.d.)
- 2.2: Control Station for Duke's TRINA System (Hauser et al, n.d.)
- 2.3: Baxter Hardware Configuration (Rethink Robotics, 2015)
- 2.4: Baxter Performing Pick-and-Place Manipulation Tasks (Hull, 2017)
- 2.5: Overview of TRINA Software Stack
- 3.1: Solidworks Rendering of Duke Designed RoboPuppet
- 3.2: Complete Duke Designed RoboPuppet Assembly
- 3.3: Universal Joint Assembly for Duke Designed RoboPuppet
- 3.4: Passive Model CAD
- 3.5: Assembled Passive Model
- 3.6: Result of Potentiometer Housing Failure
- 3.7: Exploded view of Joint W0 for passive RoboPuppet
- 3.8: Pincher Gripper Control
- 3.9: Pincher Gripper Control
- 4.1: Potentiometer
- 4.2: Calibration Fixture
- 4.3: Isolated Potentiometer Calibration Data
- 4.4: Zero Positions and Joint Limits for "Bend Joints" (Rethink Robotics, 2015)
- 4.5: Zero Positions and Joint Limits for "Twist Joints" (Rethink Robotics, 2015)
- 4.6: Testing setup for hall effect encoders

4.7: Mounting of Hall Effect Encoder on S1 Joint

4.8: Mounting of Hall Effect Encoder on S0 Joint

4.9: Motor wire management on active

4.10 Teensy 3.6 Connected to a Breadboard

5.1: TRINA Stack Process

5.2: Active RoboPuppet Software Strategy

# Acknowledgements

We would like to collectively thank a number of individuals who offered their time and resources to help ensure the success of the project:

Professor Jane Li, Project Advisor

Kevin Harrington, Robotics Teaching Lab Manager

Ken Stafford, Teaching Professor of Robotics and Mechanical Engineering

Loris Fichera, Associate Professor of Robotics Engineering and Computer Science

Doctor Erica Stults, Application Scientist

Nathaniel Goldfarb, HIRO Lab Researcher

Gunnar Horve, HIRO Lab Researcher

Ozan Akyildiz, HIRO Lab Researcher

Sihui Li, HIRO Lab Researcher

Ian Anderson, Washburn Shops Manager

James Loiselle, Washburn Shops Manager

In addition we would like to thank the numerous students, faculty and staff who have provided feedback, attended presentations, or otherwise made small contributions that helped accomplish the aims of this project



# Executive summary

## Introduction

An important duty of healthcare workers is to care for those suffering from infectious diseases. Unfortunately, their profession can also put their own health at risk. In a previous project at Duke University, the Tele-robotic Intelligent Nursing Assistant (TRINA) was developed to help reduce the risks associated with highly infectious and quarantined patients. The robot platform aimed to allow nurses to do their jobs more safely by interacting with patients remotely through a robotic device. The device consists of a Baxter industrial robot equipped with additional sensing and manipulation devices and mounted on a mobile platform. Though TRINA was able to successfully complete a number of nursing tasks in initial testing, it did so at a significantly slower pace than human nurses can. One of the reasons for this slowdown was the lack of an easy to use controller.

The goal of this project is to improve TRINA's usability by medical personnel through the development of an intuitive teleoperation interface, referred to as the RoboPuppet. In order to accomplish this, a number of objectives were laid out. First, it was important to design and fabricate the actual controller. It was also important that this device could interface properly with the TRINA software stack, as this would allow for the greatest functionality with TRINA.

## Background

The basic process of creating a RoboPuppet begins with finding a CAD model of the desired robot. The robot joints are inspected, then a watertight mesh is created from the CAD and scaled to the desired size. From here, the necessary pocket geometries are created in order for the potentiometer assemblies to fit inside the puppet. Then the puppet parts are printed and assembled, including the potentiometer assemblies. Lastly wires are connected and the system is tested. The designers recommend printing the parts with PLA or ABS plastic and building the potentiometer assemblies by soldering wires together. Hot glue is used to hold the potentiometer knob against the joint that will be turning it. (Hauser et al, n.d)

The existing controller for TRINA was the Geomagic Touch Haptic Device. This device is a link based haptic controller that can provide force feedback to users when working with computer programs such as medical training programs or digital sculpting programs. It is also used as a controller for research and development projects in fields from military work to biomedical work (Qin et. al, 2015). The major disadvantages of this device are its reduced workspace and degrees of freedom compared to TRINA.

The largest component of TRINA, and the one that this project was most focused on was the Rethink Robotics Baxter industrial robot. Originally designed to safely operate in the vicinity of human workers, Baxter's design consists of two 7-DOF arms with series elastic actuators and a torsional spring in series to reduce shock loads and add compliance (Pratt, Williamson, 1995). This, as well as a number of other safety conscious features, make Baxter an excellent choice for working in a confined space with humans.

## Mechanical Design and Analysis

Mechanically, this project focused on designing and fabricating an intuitive input device for TRINA in the form of a RoboPuppet. Initially, a prototype of a RoboPuppet for Baxter designed by researchers at Duke University was constructed for testing and analysis. Over the course of the project, two additional prototypes were developed to accomplish this goal, the passive design, which improves upon the robustness of the original design, and the active design, which incorporates motors into the design to allow for gravity compensation and haptic feedback. The two major focuses of the design were increasing structural stability and maintaining Denavit-Hartenberg (DH) parameters that are identical to the Baxter industrial robot.

Both RoboPuppets were fabricated with additive manufacturing (commonly referred to as 3D printing) and were designed using an iterative process. The rapidity and low cost of 3D printing allowed a number of prototypes to be manufactured to test. This proved especially useful in working with the tight tolerances for many of the joints.

## Electrical Design and Analysis

For the passive RoboPuppet, the joint angle sensors are 270 degree analog potentiometers. These are connected to the microcontroller, in this case an Arduino Mega, via a breadboard. The potentiometer required calibration which was done both before they were connected to the RoboPuppet to ensure linearity and after they had been connected to ensure that the microcontroller was able to accurately calculate the position of the joints.

For the active RoboPuppet, the potentiometers were replaced with hall effect absolute encoders for joint angle sensing. Despite a cost increase, there were several key reasons for the change, including increased resolution, mechanical simplicity, and the ability to use an I<sup>2</sup>C connection. These sensors connect to a Teensy 3.6 microcontroller that was chosen for its compact size, processing power, and multiple I<sup>2</sup>C busses. In addition, the active RoboPuppet incorporates motors into the design. The chosen motors are continuous rotation servos that are capable of being controller purely by input voltage as well as by an input signal.

## Control Software Design and Analysis

The software for the RoboPuppet controller is split into two major sections: the Python code running on the PC and the C++ code running on the microcontroller. For the passive RoboPuppet, the microcontroller calculates the current joint angles and transmits them to the PC over a USB UART connection. The Python code is tasked with receiving this data and passing it into the TRINA stack, which in turn controls the physical or simulated TRINA robot.

For the active RoboPuppet, the software will operate in a similar manner, but will include the ability to send feedback from the robot to the microcontroller. This feedback, in the form of the current joint angles of the robot, is used to determine the torque desired for haptic feedback. The active RoboPuppet will also implement gravity compensation, with the motor torque calculations being done by the microcontroller.

## Results and Conclusions

In general, the passive RoboPuppet was successful in controlling the robot, with some limiting factors. The RoboPuppet was able to accurately position the robot, however, the TRINA's slow operating speed meant that the RoboPuppet often became far out of sync with the physical robot. The RoboPuppet's workspace was slightly larger than the actual robot's, allowing it to utilize the entire workspace of TRINA. Though this generally made controlling the robot fairly easy it also allowed the user to position the RoboPuppet in a collision position or an otherwise unreachable pose. For the most part, however, these situations could be prevented by configuring the TRINA stack to only allow safe positions. The foot pedal system used to engage and disengage the RoboPuppet was also successfully implemented.

Despite this project's successes, there is still room for continuation. First and foremost is the completion of the active RoboPuppet. Though the hardware design has progressed to a usable state, and an arm has been constructed, there is still some refinement to be done on the design. One particular area of concern is the workspace of the RoboPuppet. Though it would likely still be sufficient to operate TRINA, the workspace is smaller than the actual robot. This could likely be improved by removing unnecessary material near the joints as well as other minor design improvements. A further step would be to implement the software for the active RoboPuppet, including gravity compensation and haptic feedback. Additional testing as well as work on the grippers will also be necessary going forward.



# Introduction

An important duty of healthcare workers, such as nurses, is to care for those suffering from infectious diseases. Unfortunately, their profession can also put their own health at risk. The CDC reported that “the incidence rate of injuries and illnesses per 100 full time workers employed in nursing and personal care facilities is 13.5,” compared to the national average of 1.8. These risks come from a variety of areas, from exposure to blood and bodily fluids through sprays, splashes and pinpricks with infected needles to ergonomic injuries from repetitive tasks like lifting (CDC, 2011). In short, nursing is an inherently dangerous profession, subjecting employees to a variety of risks, from dirty tasks that expose nurses to potentially dangerous bodily fluids, to dull jobs with repetitive tasks that can cause muscle injuries. As such, a robotic nursing platform would be a prudent choice option.

In a previous project at Duke University, the Tele-robotic Intelligent Nursing Assistant (TRINA) was developed to help reduce the risks associated with highly infectious and quarantined patients. The robot platform aimed to allow nurses to do their jobs more safely by interacting with patients remotely through a robotic device. The device consists of a Baxter industrial robot mounted on a mobile platform. The end effectors have been equipped with Right Hand Robotics brand pneumatic grippers. TRINA was designed to complete 26 common nursing tasks, split into 71 subtasks. These tasks were completed by using Baxter’s 7 degree of freedom (DOF) arms to manipulate objects such as needles and iv bags in order to carry out a nurse's duties. (Hauser et al, 2015)

After testing it was found that TRINA was able to complete 52 of the 71 subtasks. However, TRINA did so at an average rate of about 95 times slower than a nurse unassisted by TRINA. This is due, in part, to the method nurses used to operate TRINA. During the trials user described difficulty using TRINA due to a lack of precise orientation control. Additionally, some testers described issues with “understanding the robot’s combined position/orientation workspace, in particular joint limits and inverse kinematics singularities” and the “determination of a contact state change due to a lack of tactile sensation”.(Hauser et al, 2015) These complaints are all linked to the usability of TRINA’s teleoperation interface.

Our goal is to improve TRINA’s usability by medical personnel through the development of an intuitive teleoperation interface, referred to as the RoboPuppet. Specifically, this controller will consist of two arms, similar to the ones used by TRINA. Specifically, this controller will consist of two arms, similar to the ones used by TRINA. From this goal, objectives were developed that to help evaluate the final product. These objectives were organized by topic as Mechanical, Mechatronic, and Software.

### *Mechanical Objectives:*

A major mechanical objective is the development of an input device for TRINA with the same general geometries and capabilities as TRINA itself. This means the controller should have 7 DOF and a control method for TRINA’s grippers, features that most traditional input devices do not include. In addition, our RoboPuppet requires a method of preventing unintentional input to TRINA. This will allow the user to let go of the input device periodically without



involuntarily moving the robot. This improves TRINA's usability, while also making it safer to operate by preventing mistakes from accidental movement.

The RoboPuppet should also be designed to allow cables to be routed internally as often as possible. This will improve the wire management and aesthetics of the RoboPuppet by storing the cables inside of the device where they cannot be seen and are less likely to be tangled.

Given additional time, an adjustable base should be developed for the input device. This would allow users to reorient the RoboPuppet in order to place the device at a more comfortable height and orientation, reducing fatigue and increasing ease of use. Ergonomics is a key design consideration, ensuring that a user can operate the RoboPuppet without discomfort. However, the initial priority is a feasibility study of the controller, and the device height and orientation and be adjusted by adjusting the surface it rests on.

### *Mechatronic:*

In the Mechatronics category, there are two main objectives. The first objective is the selection of a sensor for measuring the joint movement of the RoboPuppet must be selected. This sensor should be able to accurately measure the position of the RoboPuppet joints for TRINA's full range of motion. The sensor must also be able to easily fit into the input device's structure, as the input device will be compact.

The second objective will be selecting which actuators, if any, will be used on the RoboPuppet. These actuators would provide a means for gravity compensation and haptic feedback. This selection will be made based on the ratio of the actuator size to the provided torque, as well as on the cost of the actuator and its ability to be moved by the user without being

powered. Additional features that the motors/servos may have, such as built-in potentiometers or encoders, will also be considered.

### *Software:*

For software, the major objective is to program the RoboPuppet to interface with TRINA in a way that is compatible with the current TRINA architecture.

If time is available, the RoboPuppet would also be able to run with the manufacturer supported Baxter SDK for Robot Operating System (ROS). This would necessitate abandoning the TRINA architecture, but would allow more researchers to integrate this system into their own projects.

Partially autonomization of TRINA is being considered as a reach objective. Completing this objective would allow TRINA to complete certain actions or entire subtasks without user input, or with very limited input. The first focus of automation would be the picking up of objects that are near the gripper.

### *Evaluation*

To achieve these objectives, two prototypes were developed. A passive model was made to measure the RoboPuppet position and control TRINA. However, this RoboPuppet has no haptic feedback. The second model, referred to as the Active RoboPuppet, uses actuators to provide the user feedback based on the correlation between the puppet position and TRINA's true position, in addition to positionally controlling TRINA. A discussion of the development and performance of these devices can be seen in below sections.



# Background

This section is an overview of the various topics necessary to understanding the motivations behind the goal of this project, as well as the decisions made during the design process. Specifically, the topics discussed will be: potential applications of the Telenursing Robotic Intelligent Nursing Assistant (TRINA), prior experiments with robotic nursing, the Rethink Robotics “Baxter” platform, and the components used in the final product.

## Applications

To better understand the needs of potential users, a study into current and potential applications of teleoperated humanoid robots was conducted. This study focused on nursing, as this is the task that the project is primarily concerned with, but also explored other areas.

## Nursing

Though an intuitive controller for Baxter has applications in many fields, the one that this project is primarily interested in is nursing. As such, it is important to understand the duties of a nurse, the skills required to complete them, and the technology that nurses already have at their disposal.

Nurses work in a variety of healthcare environments, which range from hospitals to elderly homes to in-home care. The exact nursing tasks performed depend on the type of nurse and the situation they are currently working in. However, in general, the nursing process begins

with assessing the patient. This assessment is then used to develop a care plan, which is executed by the nurse, and adapted as necessary over time. (American Nurses Association, n.d)

Evaluating and caring for patients involves nurses completing a number of physical tasks. This ranges from taking patient vitals, like blood pressure and temperature, to cleaning the patient's room and assisting in daily care activities, like helping the patient acquire and eat meals. (Nurse Journal, n.d) These tasks are repetitive, potentially expose the nurses to contagious patients, and could potentially be completed by TRINA.

However, there is also a large amount of work involving person to person discussion and human judgement, such as assembling medical histories, observing patient concerns and making healthcare decisions based on patient information.(Nurse Journal, n.d) These types of tasks often rely on the nurse having the ability to interact with the patient, and cannot currently be attempted by TRINA. As such, they are beyond the consideration of this project, but worthwhile to note nonetheless.

The physical tasks conducted by nurses were used by researchers at Duke University to develop the 26 tasks which were used in the design and evaluation of TRINA. However, it is also important to note that there are other medical workers who are put at risk by working with infectious patients. Although TRINA was designed with nurses in mind, it is possible that TRINA can complete tasks for other types of medical professionals as well.

## Other Potential Applications

Although TRINA is designed as a telepresence nursing robot, a teleoperation interface for Baxter could be useful in many fields. Telepresence robots have a number of applications, from allowing families to communicate and assist the elderly from far away locations, to helping businessmen commute remotely. Robots designed for these purposes are explored below.

Chores, such as cleaning and vacuuming, are frequently a part of everyday life and are often necessary for healthy living. These tasks, however, are often seen as tedious and time consuming. In addition, as people get older, these tasks can become too difficult to do without assistance. In order to help with this problem, companies are developing a variety of devices to help out with day to day activities. Examples range from home vacuum robots to grill cleaning robots and self cleaning litter boxes. (Tedeschi, 2014) Most of these devices are designed for only one or two applications, however, a robot like Baxter has the versatility to complete a number of these tasks. An intuitive input device for Baxter could allow caretakers to complete a number of these chores for someone incapable of doing so, saving the time and cost of having the caretaker travel to the home. In this type of scenario, Baxter would be serving a role similar to devices such as Toyota's human support robot (HSR), which are designed to accomplish a more general list of tasks, like a human helper could. The HSR achieves this with a mobile base and a gripper capable of retrieving a variety of objects, based on the user's needs. It also has a screen in order to telecommunicate with friends and family (Toyota Motors, n.d). Robots like this have the potential to ease the burden on those who struggle with typical daily activities, such as the sick or elderly.

## Prior Work

### Robotic Nursing

The wide variety of nursing tasks means that there are a wide variety of robots being developed to help make their jobs easier. These robots vary from those focused on helping with mechanical tasks to those focused on making patient interaction easier.

For example, some robots are being developed to help solve logistical problems for hospitals, such as understaffing. At UCLA, simple telepresence systems are being developed to allow nurses to look after patients without being in the same room, meaning that nurses can simply switch from robot to robot, rather than walking from room to room. These robots were strictly for telecommunication and operated by joystick. The robots consist of a monitor and a mobile base, with no method of physically interacting with a patient's room. (Vespa et. al, 2007)

Robots that focus on mechanical tasks allow nurses to do work in a patient's room while still being physically isolated from the patient. TRINA is a good example of a robot trying to accomplish these types of tasks, such as delivering trays and replacing IV bags. There are also robots, such as the Intellifill, which assists nurses by preparing IV fluid and syringes. A robot like this is beneficial to hospitals because the work can be completely much more efficiently with a robot. In addition, the process is safer than preparing the supplies by hand, as there is a smaller chance of error when mixing compounds or labeling syringes. This type of robot operates semi-autonomously, initially taking user input, then completing the syringe fluid preparation automatically (Albritton, 2007). Perhaps most importantly, these types of systems

remove a human nurse from the room, allowing them to spend time on other tasks or reduce their exposure to pathogens.

Research is also being conducted on robots that can care for patients more directly and even provide emotional support if needed. A good example of this is the PEARL nursebot, being developed to care for the elderly. Rather than carry out specific activities itself, PEARL is able to record patient schedules and remind them to perform certain tasks. It is also equipped with sensors to help it tell when the patient is not performing the tasks and is able to encourage the patient to keep up with the schedule (Pollack, et. al, 2002). Robots like this help mind patients so that nurses can spend more of their time on tasks that require their expertise.

Tele-nursing doesn't always involve using machines to complete tasks and manipulate objects. There are some systems being developed to help nurses simply survey the rooms of multiple patients at the same time. For example, a tele-ICU system is being developed to help supervise patients in intensive care units where nurses can't be everywhere at once. In this case, the tele-nursing system consists of a set of cameras surveying the room and an alert button, to allow staff to bring a nurse's attention to a specific room, if needed. In addition, the operator has a workstation that has patient information and waveforms available if needed. In this way, telenursing robot's not only help keep nurses safe, but also allow them to deal with multiple patients without having to change rooms. (Goran, 2010)

## TRINA

In the wake of the West African Ebola epidemic of 2013-2015, researchers at Duke University looked for a way to reduce the risk of nurses becoming infected when working around



patients with contagious diseases. Their work eventually led to the creation of the Telenursing Robotic Intelligent Nursing Assistant (TRINA), a Rethink Robotics Baxter industrial robot equipped with additional sensing and actuation abilities and mounted on a mobile base. Figure 2.1 shows the example of the TRINA system from Duke University.

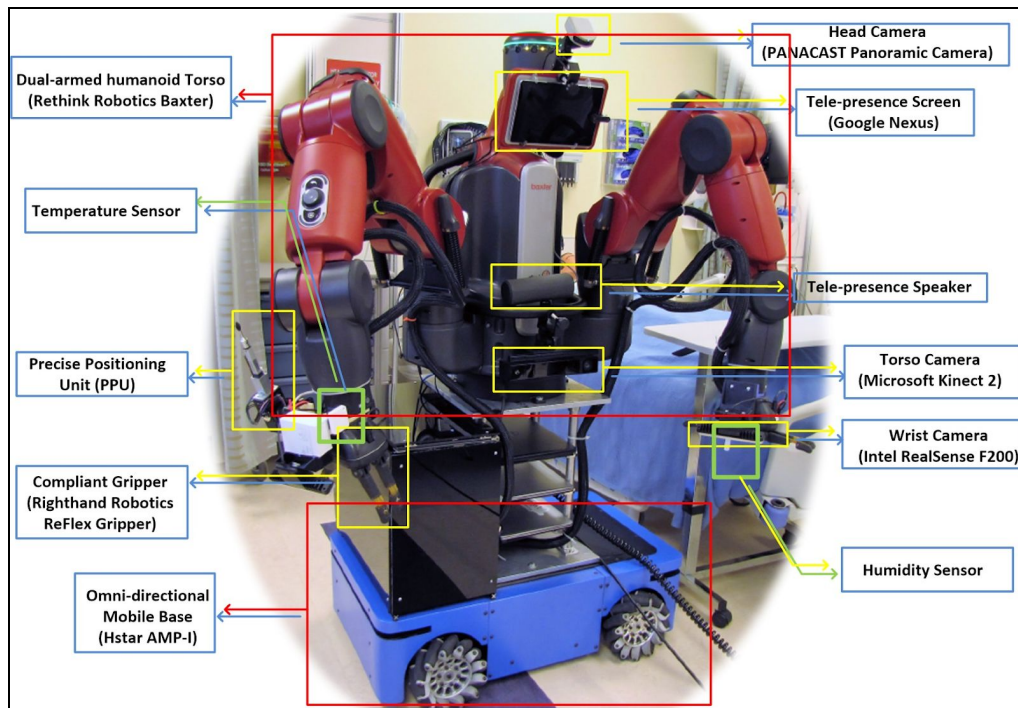

Figure 2.1: TRINA System from Duke University (Hauser et al, n.d.)

This type of research is important because healthcare workers are often the ones most exposed to these diseases, and thus the ones most at risk of catching them. During the outbreak in Guinea during 2014-2015, the risk of infection for health care workers was 42 times higher than the general population (Grinnel et. al, 2015). Though the technology did not exist during the 2013-2015 outbreak, robots and telepresence systems offer the potential to remove healthcare workers from the immediate vicinity of the patients. Preventing even a handful of these

individuals from potential exposure to ebola would no doubt have saved lives. Robots are unaffected by biological pathogens or viruses, and would be able to perform the nursing tasks unimpeded. Unfortunately, however, the type of robust, high degree of freedom (DOF), kinematic manipulators required to complete these nursing tasks are difficult to control autonomously. Furthermore, a robot's ability to make sense of tasks stated in human vernacular is still an open ended problem in artificial intelligence. Based on these issues, it was decided that TRINA would be teleoperated. To reduce the design complexity, a commercially available robot, the Rethink Robotics Baxter, was used. The robot was operated using a combination of Geomagic Touch devices and gamepad controllers. The user had an interface to view TRINA camera footage to assist with controlling the robot (figure 2.2). The initial tests of TRINA showed some promise in a novel sense; TRINA could move as commanded, and do many nursing tasks. (Hauser et al, 2015)

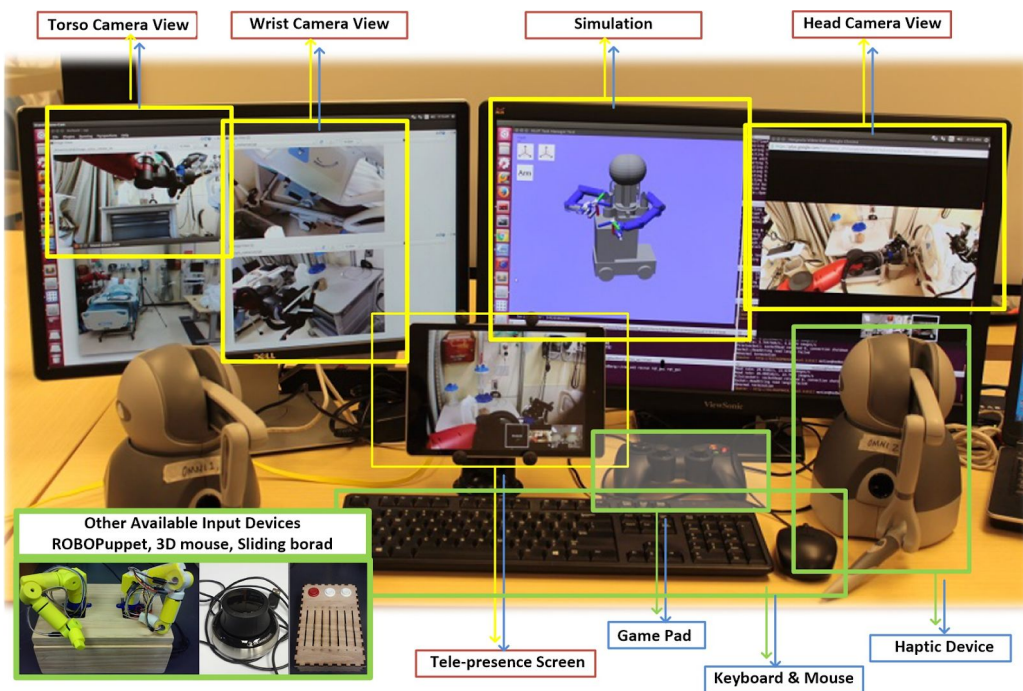

Figure 2.2: Control Station for Duke's TRINA System (Hauser et al, n.d.)

Though it was possible to complete many of the tasks, the system was very slow relative to a human, taking an average of 95 times as long to complete certain tasks. Some tasks could not be completed at all. A major issue revolves around the Geomagic Touch input devices having only six degrees of freedom, but each Baxter arm has seven. The TRINA system used forward kinematics on the haptic devices to find the input end effector pose. That pose was then mapped to a pose in Baxter's workspace. Baxter then used inverse kinematics to orient its links to the desired pose. Inverse kinematics, however, on devices with more than six degrees of freedom, can be complex and requires extra parameters to constrain the free variable. There are an infinite number of solutions for the inverse kinematics of a 7 DOF manipulator. Hence, Baxter's arms would move in unexpected ways and home in on objects from unexpected angles, leading to difficulty in operation. In addition, the Geomagic Touch used with TRINA had 6 DOF compared to Baxter's 7, which also led to a disconnect between the controller's capabilities and the robot's. Baxter's extra degree of freedom allowed its arms to move in ways that the controller could not. (Hauser et al, 2015)

More fundamentally, users reported that the system was not intuitive to operate. In discussions with Professor Jane Li, Assistant Professor of Mechanical and Robotics Engineering at Worcester Polytechnic Institute and one of the researchers on the original TRINA project, a significant problem of the old system was the training time for users to operate the TRINA system. It required over two hours of practice just to perform rudimentary tasks. (Li, 2018)

In order to improve the user's ability to operate the Baxter portion of TRINA, a major facet of this project will be testing alternate control input devices. The design for this project will be based largely off a previous input device concept designed by Duke University, know as

RoboPuppet. “RoboPuppet is a method to create inexpensive, tabletop-sized robot models to provide teleoperation input to full-sized robots.” (Hauser et al, n.d) Because these models are shaped like and move like the robots they are controlling, the creators expect that it should be easier for new users to learn how to and start operating the robots with these controllers. The RoboPuppet method has been used to make models of the Stäubli TX90L Robotic Arm in addition to models of Baxter. The TRINA team had previously considered using RoboPuppet to control TRINA, however, due to the inability of the puppet to hold its form without user manipulation, it was not tested. (Hauser et al, 2015)

## RoboPuppet

The basic process of creating a RoboPuppet begins with finding a CAD model of the desired robot. The robot joints are inspected, then a watertight mesh is created from the CAD and scaled to the desired size. From here, the necessary pocket geometries are created in order for the potentiometer assemblies to fit inside the puppet. Then the puppet parts are printed and assembled, including the potentiometer assemblies. Lastly wires are connected and the system is tested. The designers recommend printing the parts with PLA or ABS plastic and building the potentiometer assemblies by soldering wires together. Hot glue is used to hold the potentiometer knob against the joint that will be turning it. (Hauser et al, n.d)

The Robopuppet assembly has 3 separate programming components. The arduino code is used to read potentiometer values from the Robopuppet to the host computer. A python program uses these values to move the robot to the corresponding positions. There is also a safety filter

which combines the joint commands, robot dynamic model and environmental model in order to prevent safety risks such as collisions. (Hauser et al, n.d)

## Existing Input Devices

The chosen controller for TRINA was the Geomagic touch Haptic Device, formerly known as the Sensable Phantom. The device is a link based haptic controller that can provide force feedback to users when working with computer programs such as medical training programs or digital sculpting programs. It is also used as a controller for research and development projects in fields from military work to biomedical work. Reviews of this device describe its advantages as having low inertia and friction, and having high position precision. The major disadvantages seemed to be low strength and mechanical stiffness, and a small workspace. (Qin et. al, 2015)

Alternative link based haptic devices, such as the Novint Falcon, exist and are purchasable. However, the devices do not have matching strengths and weaknesses. For example the Falcon has been reported to have better stiffness and position repeatability. However, it also has more complicated kinematics and very small and inaccurate output forces. Because of the change in features, it is recommended to consider different models based on the manufacturing needs. (Qin et. al, 2015)

## Puppets

Another topic that was looked into was puppet control methods, to see if any existing systems would be helpful for controlling Baxter like a puppet. One method that was researched

was Bunraku puppetry. This method uses long sticks to control puppet limbs, with switches that control hands and other end pieces. The issue with this idea is that the switch does not provide a large amount of variable control, limiting the movement it can control. Additionally, most Bunraku controllers do not possess the needed 7 DOF. (Expertvillage, 2008)

A type of control called WALDO or the remote manipulator was also researched. Developed to control Muppet characters, this was a system that went over the puppeteer's hand and synced hand movement to the puppet movement. This style matched closely with an idea considered for controlling the robot gripper and was used as inspiration. The main difference is that the RoboPuppet glove would need to mainly record movement of individual fingers, whereas the Waldo mainly track movement of the upper and lower hand, and the wrist. (Muppet Wiki, n/d)

## Prior Technologies

In order to design a solution to the problem, so research was performed in some of the subsystems used in the prototype and final designs.

### Rethink Robotics Baxter

Originally designed to safely operate in the vicinity of human workers, Baxter is a multipurpose industrial robot from Rethink Robotics. Baxter's design consists of two 7-DOF arms connected to a central body with a display screen, webcam, and sensor suite (Rethink Robotics, 2015). Each joint features series elastic actuators and a torsional spring in series to reduce shock loads and add compliance (Pratt, Williamson, 1995). Each arm ends in a connector

for a gripper, either the default parallel gripper version, or a third party model. For this project, a compliant three-fingered gripper from Righthand Robotics is mounted to each arm. Each arm is also equipped with a camera near the wrist to aid in precise teleoperated control. Figure 2.3 shows the manufacturer's joint angle notation and overall geometry of Baxter.

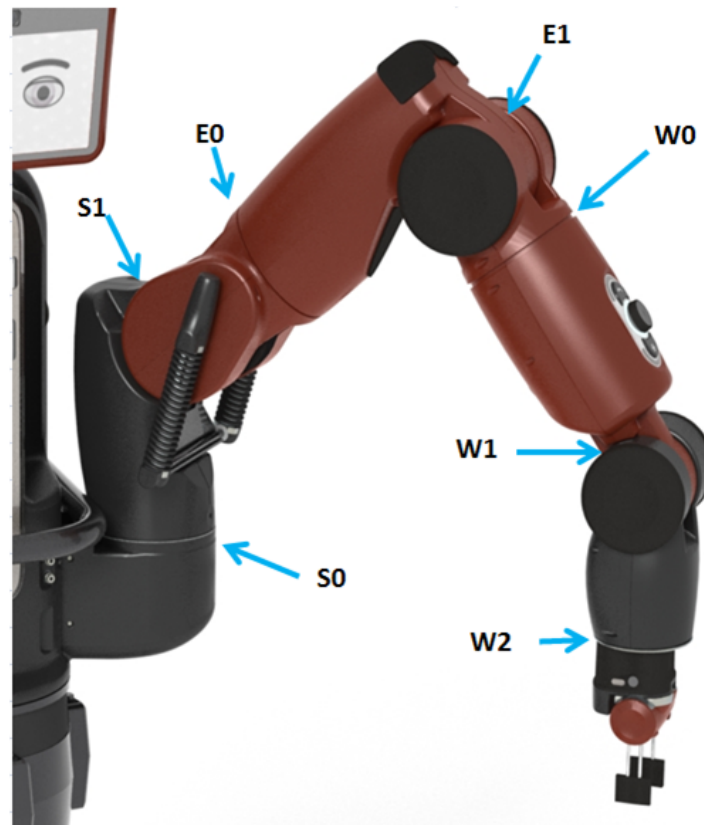

Figure 2.3: Baxter Hardware Configuration (Rethink Robotics, 2015)

By default, Baxter is equipped with software to allow a user to program it by picking up its arms and moving from pose to pose. The motion is recorded, and can be repeated by the robot itself on an assembly line. Additional optimizations with cameras can be used to more accurately detect the location of objects. Figure 2.4 shows a typical industrial application of Baxter on an assembly line.



Figure 2.4: Baxter Performing Pick-and-Place Manipulation Tasks (Hull, 2017)

However, for this project, more robust control is required, as a nurse is interested in performing many tasks in slightly differing environments, rather than repeated executing the same motion. Thankfully, Baxter is not restricted to its default industrial programs, and researchers are able to implement their own custom software.

## Mechanical Systems

Haptic devices are any device that can give a sense of touch to the user, such as a smartphone that vibrates when pressed. Haptic controllers use haptic feedback to give users a sense of how the device is interacting with its environment (Park, Lee, Sziebig, 2016). Force feedback joysticks are an early example of a haptic controllers and were often 2 DOF devices. Another example are the point type devices, such as the Geomagic Touch, which usually consists of serial links and are used to move a specific point on a device. A complaint of these devices is that the 6 DOF it generally provides is not enough to mimic a human arm. Besides the Geomagic



Touch, other devices include arm mounted haptic devices and gloves, in conjunction with a video motion capture system. These are haptic devices that are meant to map human movement as closely as possible. (Qin et. al, 2015)

When building haptic devices, a form of actuation is needed to provide the force feedback. This is usually a vibration motor. Typical vibration motors consist of motors with unbalanced weights on the end that cause the vibration, due to conservation of angular momentum. Another type of vibrational motors is linear resonant actuators (LRAs). LRAs can vibrate to deliver variable force feedback along a given access, where other vibrational motors vibrate in two axes. (Precision Microdrives, n.d)

Given that the device is intended to be used for long periods of time, ergonomics is a large concern. Certain body positions and repetitive motions can expose workers to risks of Musculoskeletal Disorders. (United States Department of Labor, n.d.) Working with the robopuppet the design may involve some of these at-risk positions. Though the input device cannot entirely eliminate these hazards, it is important to take steps to mitigate them by taking ergonomics into consideration. In order to improve operator posture it is important to have the monitors being used to monitor the real-world robot at eye level and directly behind the control device. (Mayo Clinic, 2016) In addition, it is recommended that tools be padded and as light as possible. Maintaining a straight neck and wrist when using tools is also advisable, so tools should be placed in areas where severe bending is not required. The RoboPuppet may have to be adjustable in order to be ergonomic and safe to operate for users of different heights and body shapes. Another ergonomic best practice is to hold materials in place with clamps or other devices, so that users don't have to exert themselves

holding things in place. This means that it will be important for safety that the robopuppet can maintain its position without constant user input. (Lampl, 2008)

## Mechatronic Systems

It was decided early in the project, that some form of torque feedback would need to be installed on the puppet. A significant amount of research was undertaken to understand which technologies to use, how to implement this actuation, and the best practices. The purpose of the torque feedback has many uses:

- Link resting: Allows the links to remain “floating” while the user is not operating the puppet. Can be toggled on with a dead man switch floor pedal. This feature is necessary to maintain safety. If the user lets go of the input device, for any reasons, the controlled Baxter will reciprocate and lower its arm, and potentially dropping things.
- Gravity Compensation: Applying a torque on each link, that is equal to the moments induced by the weight of the rest of the arm links. The user will need significantly less effort, and perceive the input device as “weightless”.
- “Soft” Force feedback: Moving the puppet links too quickly could cause the robot to go out of control. Baxter does not move very quickly, and it is quite easier for the user to move too quick and the controller becomes disjoint from the real robot. A torque can be applied that is in proportion to this error. More substantial differences will be responded to through stronger haptic feedback.

To apply a torque on the joints, different forms of actuators were researched. The first type of actuator were electric motors, which can be divided into DC permanent magnet motors and AC, field wound motors. In addition, motors can be classified as brushed or brushless - referring to the way that the armature is located within the stator. However, controlling any of these motors would be difficult, as they would need to be controlled in a way that is against their intended design. Rather than rotate as a given speed, and apply a torque dependent on the environment, it is necessary for the motors operated at a given torque, and apply a speed that is environmentally dependent. To research what qualities would be needed, an interview was conducted with Professor Kenneth Stafford. From the interview, several key motor variables were discussed.

1. The motor must supply the requisite power or it cannot be used. While a great first step for selection of motors in more typical applications, since the angular velocity is arbitrary for this haptic devices, it is difficult to quantify the power requirements.
2. Gearboxes are used on motors to reduced the shaft speed and increase torque. However, gears do have frictional losses. A threshold of 200:1 was given as the maximum acceptable gear reduction. Beyond that, the user would not be restrained by back-emf, but by friction between gears. A more ideal situation would be a 100:1 reduction. In addition, worm gears, and other non-backdrivable gearboxes will need to be avoided outright.

Since the controller links should not be rotated quickly at all, and the motor cannot be aided by a high reduction gearbox, the motor must be able to operate well at low speeds.

Moreover, the electrical current required to apply the necessary torque from the motor, must be

within the safe operating limits of the motor and power delivery subsystem. In addition, the motors will need to operate predictably with less than their nominal operating voltage.

Magnetic breaks, also called hysteresis brakes apply a resistive torque that is proportional to their angular velocity. Although similarly constructed to motors, they are not designed to drive a rotational load, but rather restrict the speed of shafts on machines, that are externally driven. This makes the breaks very good for locking the RoboPuppet in place, but does not allow for haptic feedback. Additionally, the torque to weight ratio was lower than the cheaper and more easily to obtain servos. This ultimately led to considering other options for actuation.

An alternative to using motor torque to provide feedback would be with vibration motors. The key benefit is they do not produce an angular displacement on the joints, which would help maintain accuracy, and do not need to be coupled between links, which would simplify the mechanical design. However, the vibration motors cannot produce a torque to keep the arm from moving. This would mean relying fully on the user to adjust their manipulation speed, based on the directives of the vibration motors, rather than using the torque to push back against user's input. These motors would also be unable to perform any form of gravity compensation,

One key problem with motors and other such devices is that they need to be mounted directly to the arms. For gravity compensation, this is additional weight that must be supported, thus requiring larger, heavier motors. The Davinci surgical robot has a similar design constraint, as it requires slender limbs to operate in tight spaces. To overcome this obstacle, the Davinci robot uses a cable and pulley system to actuate its joints. This allows the actuators to be stored remotely in the base unit. Three main complications exist with this implementation. A complicated internal pulley system would need to be designed. If the input device is kept at a

size which would still be ergonomic to operate, the mechanical design would be unprecedented and perhaps impossible. Second, the cables must be kept in constant tension in both directions (to ensure full mobility of the arms), which would add significant complications to the assembly. Lastly, the DaVinci surgical robot uses braided tungsten cables as any elongation would significantly hinder precision. Such cables are are substantially beyond the budget of this project.

## Software Systems

The main software architecture used for the project is the TRINA Software stack. It is an integrated middleware, motion planner, simulator and controller interface software stack. In order best integrate with other researchers at the WPI HIRO Lab, the use of this software stack is a constraint. Figure 2.5 diagrams the TRINA software system

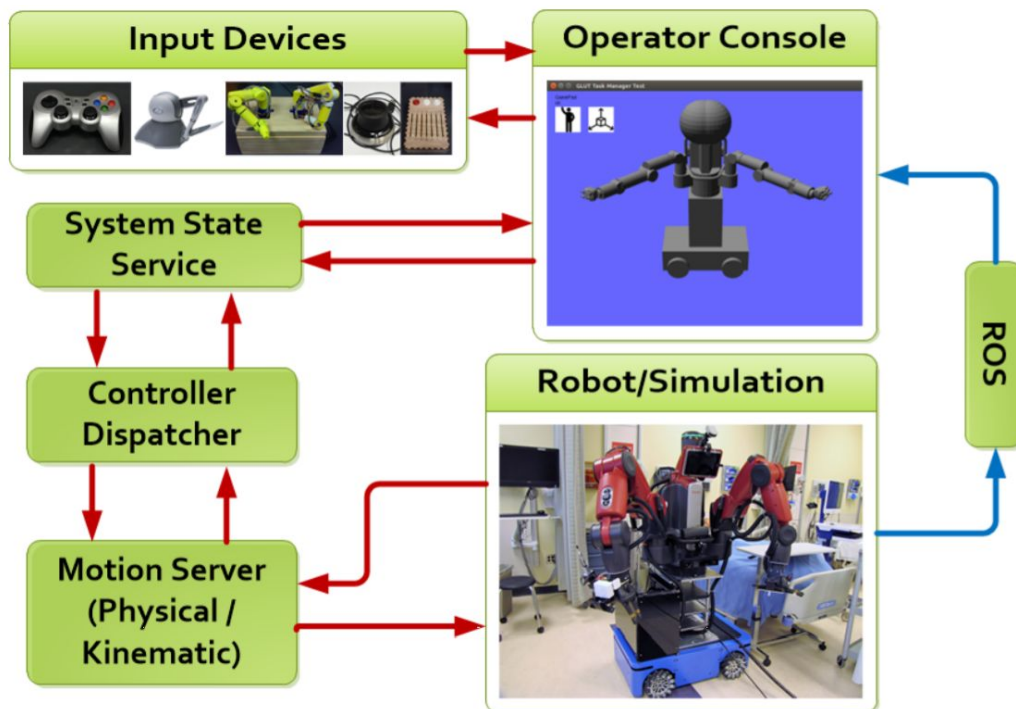

Figure 2.5: Overview of TRINA Software Stack (Hauser et al n.d.)

The software that TRINA, and this project is based on is the Robot Operating System (ROS). Despite the name, ROS is not an operating system, but rather a code framework. At the heart of ROS is the idea of modularity. A robot operating with ROS will typically run a number of nodes, each handling specific functions, as well as a core that facilitates the passing of information between the nodes. In order to communicate, ROS nodes publish messages containing data to specific topics. Other nodes listen to these topics waiting for messages to be received and operate on that data, either using it to affect motion of the robot or publishing the results to a different topic. By separating the robot software into subsystems, ROS offers the ability to easily adapt code to different systems. Rather than publishing code that is specific to a single robot, ROS allows programmers to create code independent of firmware. It is important to understand the underpinnings of ROS to fully understand the functionality of the TRINA Stack. However it should be noted that all of the ROS commands are abstracted away, and allows the system to function at a much level.

# Mechanical Design and Analysis

Mechanically, this project focused on improving the design of the robopuppet. Initially, a prototype of the Duke Robopuppet was constructed for testing and analysis. Over the course of the project, two additional prototypes were developed to accomplish this goal, the passive Robopuppet design, which improves upon the robustness of the originally design, and the active RoboPuppet design, which incorporates motors into the design, as well as adding other improvements based on Mark 0 testing. The two major focuses of the design were increasing structural stability and maintaining Denavit-Hartenberg (DH) parameters that are identical to the Baxter industrial robot. The following sections describe the processes and analysis involved in the development of each prototype.

## Duke Arm Design

The initial inspiration for the project's design was the preliminary Baxter RoboPuppet developed by researchers at Duke university. The design was an initial feasibility study to confirm that the RoboPuppet procedure could be applied to Baxter. (Hauser, n.d) The joint angles were sensed using potentiometers attached to the arm via a universal octagonal joint mount. The W2 joint is not modeled in this design,.

To evaluate the strengths and weaknesses of this design, the team constructed a prototype based on CAD from the Duke project. This design posed several difficulties. First, the device is entirely passive. There is no actuation feedback to the user, and the user must support the puppet

arm's entire weight. With no actuated feedback, users sometimes moved the arm too quickly for the robot to respond, leading to a disconnect between the puppet's position and the robot's position. Furthermore, letting go of the Duke RoboPuppet would cause Baxter's arms to similarly fall. Second, the potentiometer assembly was not as durable as needed. The potentiometer itself is a load bearing member, and it is supported with a small 3d printed collar (see figure 3.6, in Passive RoboPuppet design). During the tests of the Duke prototype, this collar sheared off on most joint assemblies, and necessitated the use of glue to hold it back together. Additionally, during tests team members expressed concerns with the device being uncomfortable due to its small size. The Duke arm also lacks one degree of freedom, which prevents the device from being able to completely mimic the behaviour of the Baxter robot. This was a top priority to be fixed in future designs.

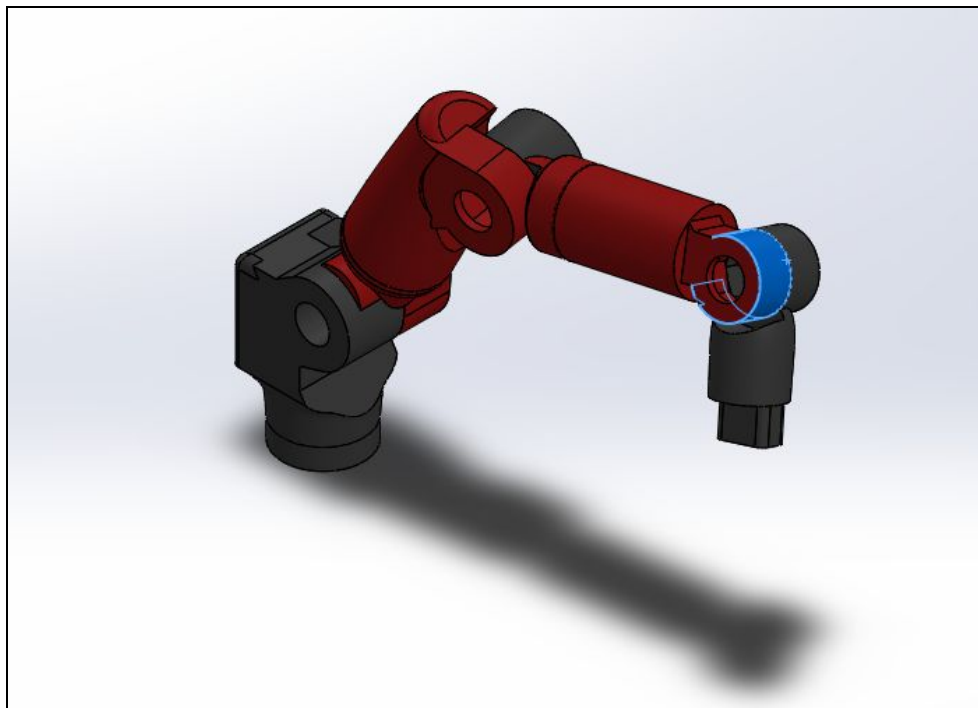



Figure 3.1: Solidworks Rendering of Duke Designed RoboPuppet

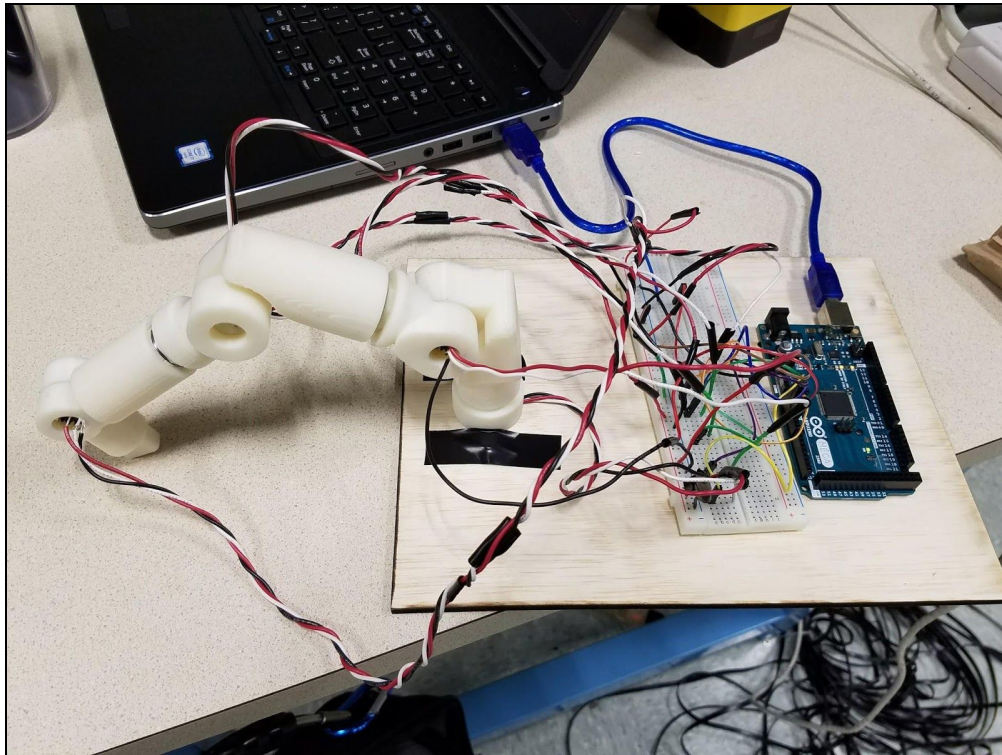

Figure 3.2: Complete Duke Designed RoboPuppet Assembly

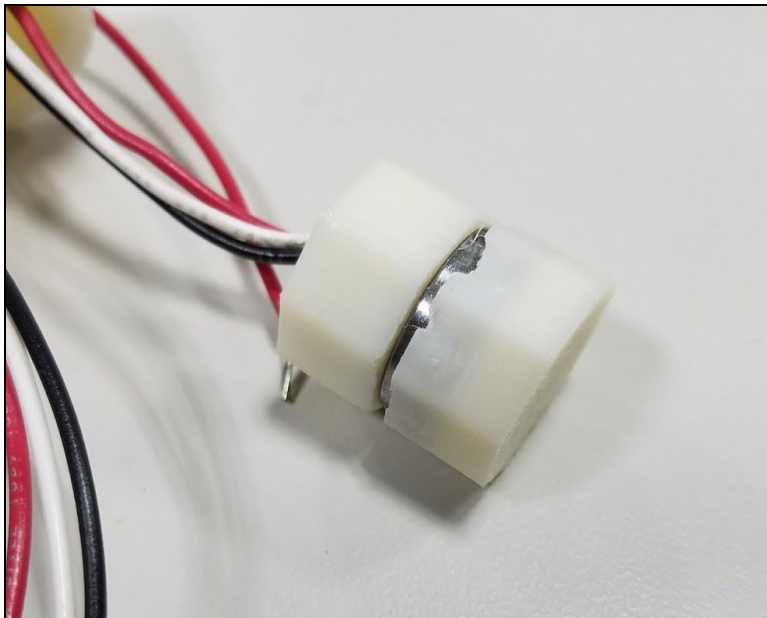

Figure 3.3: Universal Joint Assembly for Duke Designed RoboPuppet

## Passive Robopuppet Redesign

It was determined early on, that the team would create a redesign of the original Robopuppet, without active motor control, before an active design was created. This design was referred to as the Passive RoboPuppet. This passive puppet would help ensure that the team had a durable baseline design, before motors were added. This design was also served to test rotational potentiometers as the position sensors for the joints. It also allows the software to be designed and tested in parallel with the mechanical systems, and as a proof of concept for using the RoboPuppet process to control Baxter, before complicating the system with feedback actuators. A solid model of the arm and an image from testing is included below.

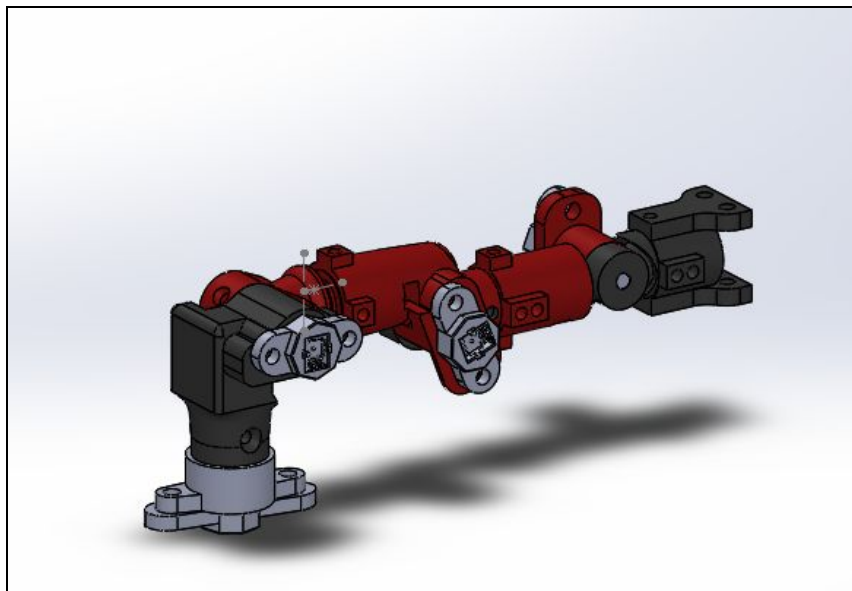

Figure 3.4: Passive Model CAD

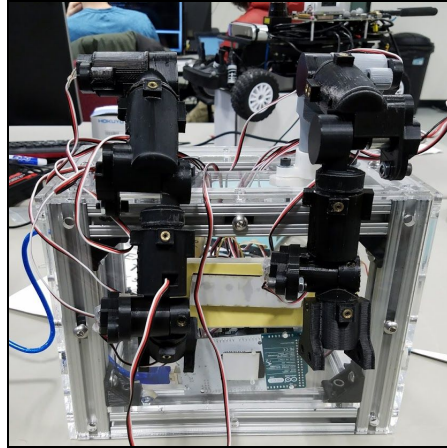

Figure 3.5: Assembled Passive Model

A main focus of the passive puppet was improve upon the initial design, based on the initial research and the needs of TRINA. A major addition was the inclusion of a seventh degree of freedom to the puppet. This allowed the user to control every joint of baxter individually and helped make the puppet movement and behavior more accurately match that of the robot. The other major change was the method of integrating potentiometers and connecting joints. Originally, the potentiometers were inserted into housings which consisted of two octagons which rotates freely with respect to each other. One end of the housing was inserted into each end of the joint, connecting the links. The housings meant that each pot assembly was identical, and made the design for each link similar. However, the potentiometer was press fit into the assembly, and was located at the center of joint. This meant that the housing experienced the majority of forces exerted on the puppet. Interior components of the housing were very thin and resulted in the housing breaking frequently. Figure 3.6 shows the result of a sheared

potentiometer housing. The central boss in the center of the octagonal housing, which has broken off, contains the potentiometer knob.

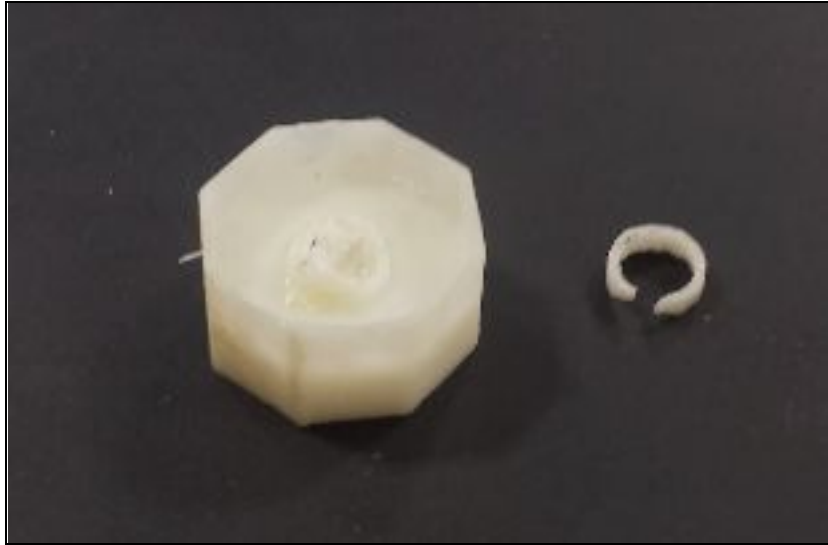

Figure 3.6: Result of Potentiometer Housing Failure

In the passive redesign, the issue of the delicate housing was resolved using multiple methods. First, the sizing of the various components was changed so that the housing walls could be thicker, and more robust. In addition, shafts and shaft collars were added to the design. The new design uses shaft collars to support the majority of the forces from the arm, keeping this load off of the potentiometer housing. Figure 3.7 shows an exploded view of the improved W0 joint on the passive Robopuppet. Inside is a rapid prototype housing for the potentiometer, a custom machined aluminum coupler, and a steel D-shaft. The joint restrict axial separation, and enforces potentiometer joint limits by slotting set screws into the tracks on the leftmost part.

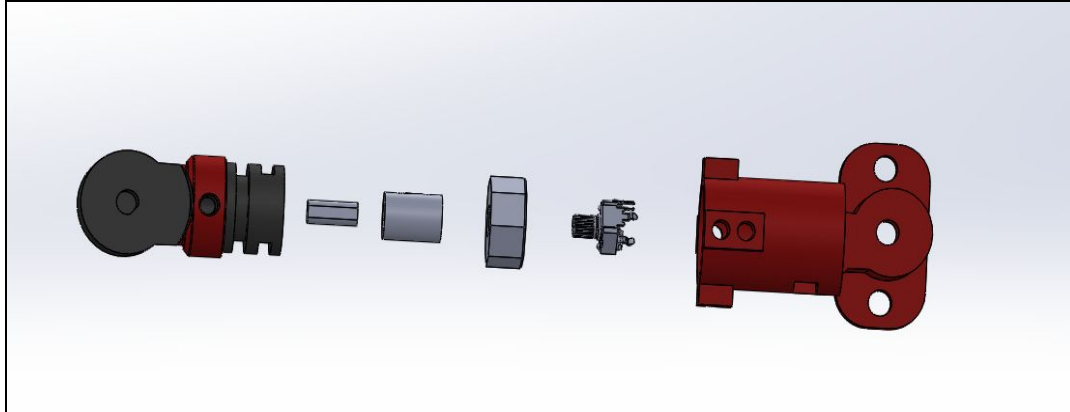

Figure 3.7: Exploded view of Joint W0 for passive RoboPuppet

### Analysis of Passive Version

Our main method of analysing the passive arm was destructive testing. Specifically, the arm's structural integrity was tested under two conditions, under maximum static stress and under repeated fatigue loading. We selected to mainly test the arms physically as most construction was done with 3D printed ABS plastic. This makes the material properties difficult to predict and would make most calculations inaccurate. By physically testing the prototype we were able to observe and study any failures in order to locate the cause. The two conditions were selected because these would be the most likely cause of failure in the arm.

This testing analyzed the structural stability of the passive design, as well as the strength of the 3D printed material used. During testing, links that had failed under low loading were printed in different orientations. This change affected the direction that the plastic layers ran along the part. It was observed that parts were stronger when force was applied in parallel to the plastic layers, rather than perpendicularly.

A secondary analysis method was to calculate the torque acting on each joint of the arm. This type of analysis allowed us to get a sense of the loads on each of the different joints. This is important because it allowed us to see how much more force was being experienced by the bottom most joint than any of the others. We made these calculations using measurements taken from SolidWorks and assuming that the arm was solid ABS. An excel spreadsheet was used to calculate the torque values for various joints on the arm (See Appendix IV). This assumption was incorrect, as the printed PLA is significantly less dense. However, this decision resulted in considering higher loads, which led us to create a more robust design. Ultimately this analysis lead to the addition of springs in the active arm design. This analysis was also used to determine the torque output needed from the servos in the active design. All servos were selected to be able to support the highest load experienced by the arm without stalling.

## Active RoboPuppet Model

The fully actuated arm is designed to both incorporate motors into the robopuppet controller, as well as continue to resolve issues observed during testing of the passive arm designs. There were five key modes of improvement that the active RoboPuppet presents.

1. Improvement on manufacturing ability. Many of the links were designed with flat spots or split to create flat spots and facilitate easier FDM rapid prototyping
2. Reduce friction. This was accomplished by the adding of bearings to all joints.
3. Improve on sensing, through the upgrade from potentiometers to Hall effect encoders
4. Added space availability to improve cable management and ergonomics.

5. The implementation of motors for haptic feedback.

## Actuator Selection

The key improvement with this design is the introduction of actuators on the joints. This actuation serves two purposes: gravity compensation for the weight of the links, and haptic feedback for the user. Several methods were considered to achieve this. Descriptions of each option are provided below, as well as the decision matrix used to rank the options. In addition to rank, price and availability were considered during the design process.

### DC Motors

These are basic DC brushed motors. These are good for operating at high speeds, but require frequent maintenance and often produce less torque than the brushless counterpart. They can be compacted and can have direct velocity control.

### DCBL Motors

These are standard brushless motors. They produce more torque than brushed motors and are frequently more expensive, however they can be more power dense and size efficient.

### Servo Motors

Servos are motors that feature an integrated gearbox and controller for simplified control. The team specifically considered 360 degree rotation, metal gear, micro servos, as they would fit the application best in this very general classification of actuator. These servos are able to rotate

continuously, similar to a motor, rather than having a limited angle range. The metal gear versions are durable and can produce large amounts of torque for their size.

### Marionette suspension system

This option would use cables to suspend the arm controller in the air. Brakes would hold these cables in place when the user was not manipulating the arms. For this design, fixed pulleys would restrict the movement of the arm. An additional concern was that cables would become tangled. A benefit was that this solution was non-electrical and needed no wiring or power supply. However there would be difficulties in installation, and ensuring the strings to not collide.

### Hysteresis Brakes

These brakes use magnetic fields to stop the shaft inside of the brakes. When active, the shaft stops in place, preventing the arm from being able to rotate and locking the shaft in place. These brakes can resist the needed amount of torque and are roughly the diameter of the Duke Robopuppet prototype. However, they cost \$280 per unit, which is antithetical to the affordability objective for the project as a whole.

### Magnetic Clutch

These clutches stop shaft rotation using friction between two materials to resist the shaft motion. Magnets are used to pull these materials together and create the friction. The option resists enough torque to hold the robot in place, but less than the hysteresis option. These brakes



are similarly sized to the hysteresis brakes, however it is unclear from the vendors whether they can provide a partial break, or if it is a full-stop-or-nothing. This solution cost roughly \$60 per unit.

### Mechanical Clutches

This type of clutch would use friction to stop shaft rotation, similar to the magnetic clutch. However the clutch would be cable driven instead of magnet driven. This method could be homemade rather than ordered. However this would require a significant amount of novel design. Looking into similar pre-existing solutions such as sprag clutches, it may also be difficult to produce a design that works in both directions.

Design	Ability to Gravity Compensate	Ability for Haptic Feedback	Effects on range of motion	Size (within the joint)	Heat output	Complexity (Simplest to Most Complex)	Cost (Low to High)
DC Motors	Yes	Yes	None	Bulky	Moderate	Simplest	Low
DCBL Motors	Yes	Yes	None	Med	High	Simplest	Low
Servos	Yes	Yes	Joint Angle limiting	Compact	Moderate	Simplest	Low
Continuous Rotation Servo	Yes	Yes	None	Compact	Moderate	Simplest	Low
Cable System	Yes	Yes	None	Compact	Moderate	Most Complex	High
Marionette System	Yes	No	String Collisions	N/A	None	Most Complex	Med
Hysteresis Brakes	No	Yes	None	Med	Low	Simple	High
Clutches	Yes	No	None	Med	Low	Simple	Low

The above matrix discusses how each solution matches our essential criteria. We were looking for an option that could lock the robot arm in place without restricting the motion ranged. Preferably, these could also be used to implement haptic feedback. For the size, we considered whether the option could fit in the joint as was originally designed(compact), needed slightly more space(med) or could not fit in the joint(bulky). Heat output, and difficulty of implementation were also considered. Ultimately the three best options were servos, hysteresis brakes and magnetic brakes. All three of these options produced the needed amount of torque. However, the servos were slightly smaller than the other options and significantly less expensive. In addition, the magnetic brakes had a large lead time. Specifically, we went with the TowerPro Continuous Rotation micro servo based on recommendations and reviews.

## Preliminary Hand Design

The original design for gripper control consisted of two plastic “finger” links connected to a plastic base. The fingers were connected by a set of gears to ensure that the fingers could only move in proportion to each other and would always meet in the center. These fingers were meant to resemble the grippers used on Baxter, and the pinching motion represented the closing of the gripper hand. The position of the fingers was measured by a shaft mounted potentiometer. The plastic base was design to attach to the end link of the RoboPuppet. The end attachment is identical for the passive and active models. The assembled model can be seen in figure 3.8.

This design measured how open the fingers were, allowing the grippers to open varying amounts. However, the fingers made the device bulky, requiring two hand to operate. This meant

that only one gripper would be able to be used at a time. This led to the consideration of alternative designs.

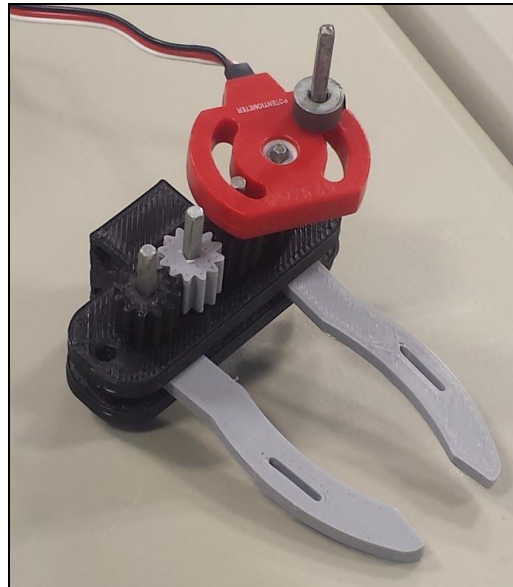

Figure 3.8: Pincher Gripper Control

## Button Design

This design was used as the gripper input device on the final design. The device mounts to either RoboPuppet model, similar to the pincher device. However this device controls the gripper using a button. The gripper closes on button press and opens on button release. The button is encased in a printed housing, which includes the previously mentioned mount. The device can be seen in figure 3.9.

This device lacks the in depth gripper control of the pincher method, but is significantly easier to use. It can also be operated using only one hand.

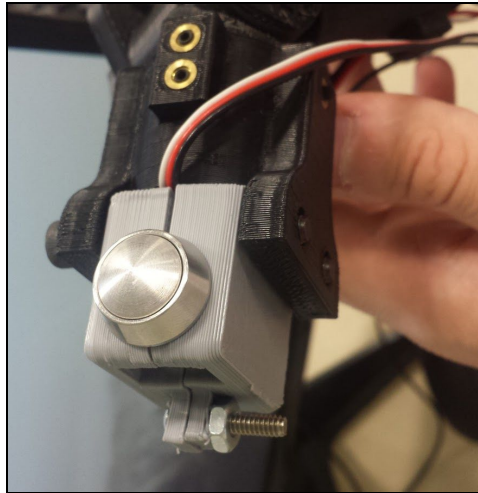

Figure 3.9: Pincher Gripper Control

## Manufacturing

The goal of the fabrication process is to create a product that matches the design specifications. The primary factors that affect the outcome of the product are the fabrication method selected for creating the part, and the material used in this method. The fabrication process usually begins with the construction of individual pieces, followed by assembly. In addition to creating components, the more common pieces are purchased.

The first step in our design process, was to recreate the original robopuppet design for baxter, using provided CAD files. 3D printed versions of the original puppets had been created before the start of this project. However, the bearing assemblies were not correctly sized and had to be recreated, using a Dimension Machine. In addition, the assemblies had some walls thinner

than could be accurately printed in some areas. To fix this, parts were printed with thicker walls and filed down the edges.

Once the pieces were ready, the robopuppet was assembled. In order to be sure only the original design was tested, the only modifications to the design were additions necessary for safe testing. Specifically this was a method to hold the puppet steady when trying to set up and turn off the device. These parts were printed with ABS plastic, because it was a standard material used with the machine that had previously been used to make the Robopuppet parts. Aside from the printed parts, bearings and potentiometers that had previously been purchased for this project were used.

The next design was of our passive robopuppet design, improving on the Duke Model. The majority of the arm was printed using a Lulzbot printer. The major modification to this design was the change in location of the potentiometer. Rather than being inserted as part of the joint assembly itself, the potentiometers were located a distance away from the joint and connected to the joint assembly with shafts. Another change was that this design included both a left and right hand. Links for the two arms were mirrored in order for the distinction between the two arms to be clear.

In addition, couplers were needed to connect potentiometers to the shafts, which were added to the design. These couplers were machined from aluminum rods using lathes and drills. In addition, heat set inserts were added to some 3D printed pieces in order to allow set screws to be inserted into the part. These screws were used to hold the shafts into place. In addition, these screws were inserted into slots, as part of the assembly of wrist joints. The slots kept the two links from separating from each other while allowing them to rotate freely. However the slots

and set screws created a large amount of friction, which had to be reduced using silicone grease. The set screws used in the assembly also came undone somewhat easily. To compensate for this, extra clearance holes were added to each link to provide easier access for removing shaft collars and adjusting the set screws within. Loctite was applied to the screws to help prevent future loosening as well.

For the first arm of this design, one link cracked along the direction of the ABS threads. To fix this, a replacement was created, printed in a different orientation. This changed the directions of the ABS threads throughout the part, making it stronger.

For the Passive design, wrist joints were created by inserting a slotted cylindrical link into a hollow link. Set screws were then inserted into the slots to hold the joint together. This kept the new design similar to the original Duke design. However, printing these parts required support material that was difficult to completely remove from the finished part. This added extra time to the manufacturing process. Rough edges from where support material was removed also made it difficult for some parts to fit together. This led to prioritizing an ease of 3D printing when creating our design of the active puppet.

Once the initial puppet was completed, work began on fabricating the initial designs of the gripper controller, as no initial design existed for this component. To simplify assembly, the gripper controller was designed to use vex shafts and standoffs. The design consists of two 3D printed halves of a hand. Two curved, printed fingers were added at the left and right edges of this hand. They were connected by 3D printed gears, so that the two fingers moved together. The gear ratio was 1:1. The fingers included hook and loop straps that could be used to attach the

fingers to the user's real fingers. This would allow the user to more easily manipulate the controller.

The final prototype constructed for this project was the Active design. This version included motors, to help keep its position when not in use. This version also replaced the potentiometers with hall effect encoders, due to the sensors providing a better joint angle reading.

This arm design print links in two halves. This allowed for pieces to be printed with fewer supports, and also allowed for motors and shafts to be more easily inserted inside during assembly. This version used the same printer, shafts and set screws as the passive design. It used new custom couplers to attach to the hall effect magnets, made from the same stock as the passive design. Using the same base components allowed for easier transfer of design components from the passive to active design. Like all the previous arms, the links are all very similar to each other. However, the actual link design for the active is differs greatly from the Duke design in order to better accommodate the added volume from the motors.

For assembly the bottom most joint, referred to as S0, was assembled before the other pieces were manufactured. This allowed for identification sizing and tolerancing issues and adjust the future parts to accommodate the errors. It also allowed for testing of the motors, sensors and structural integrity of the concept before committing too many resources to the design. Once this first joint was created, the other links were manufactured and added. The majority of the Active model was 3D printed, though shaft collars were machined from steel for added stability.

# Electrical Engineering Design and Analysis

This chapter contains the design and analysis of the electrical subsystems in the Passive and Active RoboPuppets. The section will cover the sensing capabilities, actuation, onboard processing, power delivery, and wiring sub-systems.

## Arm Angle Sensing

It is imperative to sense the angle of each joint in the RoboPuppet's arm, as these are the control inputs to Baxter. For the passive RoboPuppet, potentiometers were used for their compact packaging and ease of use. For the active robopuppet, hall effect absolute encoders were chosen for their superior precision through the use of 14-bit ADCs, mechanical durability due to lack of a mechanical linkage, and ease of implementation thanks to the integrated digital signal processors.

### Passive RoboPuppet Arm Angle Sensing

The Passive RoboPuppet draws significant inspiration from the original Duke designed RoboPuppet. Hence, the same potentiometer joint angle measurement system was employed. The potentiometer used is a 270 degree analog potentiometer. Figure 4.1 is a photo of the potentiometer before installation into the passive RoboPuppet.





Figure 4.1: Potentiometer

It is necessary to calibrate the potentiometers in order to relate the signal they output to the angle that they measure. Two procedures were done. First, a single potentiometer was calibrated in isolation in order to get a sense of the data trend. Second, the potentiometers were calibrated on the arms themselves to relate the arm-relative position to the signal that is outputted. Figure 4.2 demonstrates a fixture used to measure the angle of the potentiometer in isolation for calibration. The potentiometer was set to various known angles, and then data was captured. The potentiometer was wired such that a 5 volt supply was applied, and the return signal was fed into an Arduino Mega microcontroller's 10-bit analog-to-digital converter. The microcontroller transferred the sensor data over usb to a host computer. Using PuTTY, the data was collected into a Google Documents spreadsheet, to perform numerical analysis.

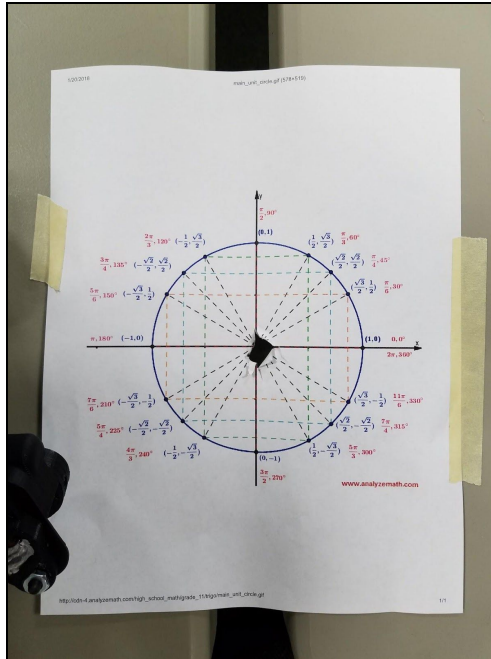

Figure 4.2: Calibration Fixture

The isolated potentiometer demonstrated that the sensors are nearly linear with an  $R^2$  value of 0.988, which indicates a clear correlation to the linear curve fit. Figure 4.3 shows the results from testing with 1676 samples. Note that the angles on the graph are set so that the rightmost hardstop is zero degrees.

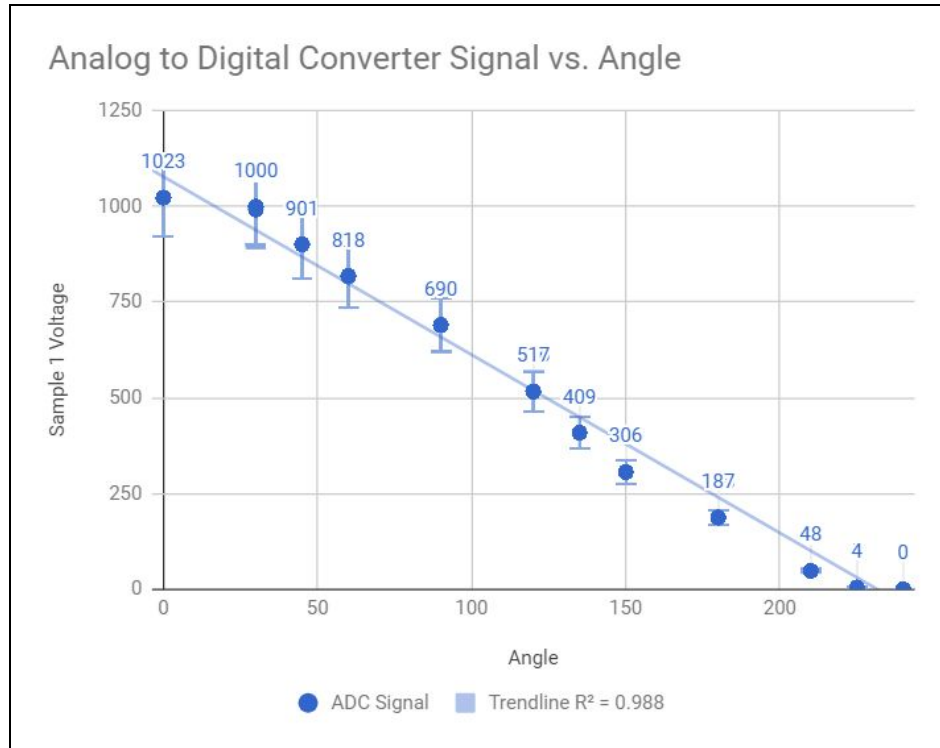

Figure 4.3: Isolated Potentiometer Calibration Data

The sensor is most linearly between 30 and 220 degrees but there is a significant divergence near the ends. There, the angle changes, but the signal does not. The cause is likely do to a low quality application of the resistive material, where at the extremities, only exists a direct conductor to either the high or low power rails. This dead zone is problematic as it is impossible to perform the inverse process, finding the angle by reading a sensor data, as a single value could be one of many angles. This problem was largely resolved by mechanically adjusting the potentiometers so that they need not operate in these domains.

Once the single pot was tested in isolation to confirm the linear model and to determine the extent of the dead zones, the joints on the passive robopuppet themselves were calibrated. A nearly identical procedure was done to calibrate the potentiometers. Instead of the printed guide,

a protractor was used to measure the angles off of the zero positions. The known angles were held as data and captured to create graphs, from which linear trends were formed. The zero positions of each joint are defined from the Rethink Robotics hardware specifications for Baxter, as that convention is used elsewhere in the software stack. Figures 4.4 and 4.5 indicate where the zero degree points are for each joint, as well as their range of motion. The dashed grey lines represent the zero angle when the direction of the links (solid black indicator lines) are coincident. The solid grey lines are the joint limits.

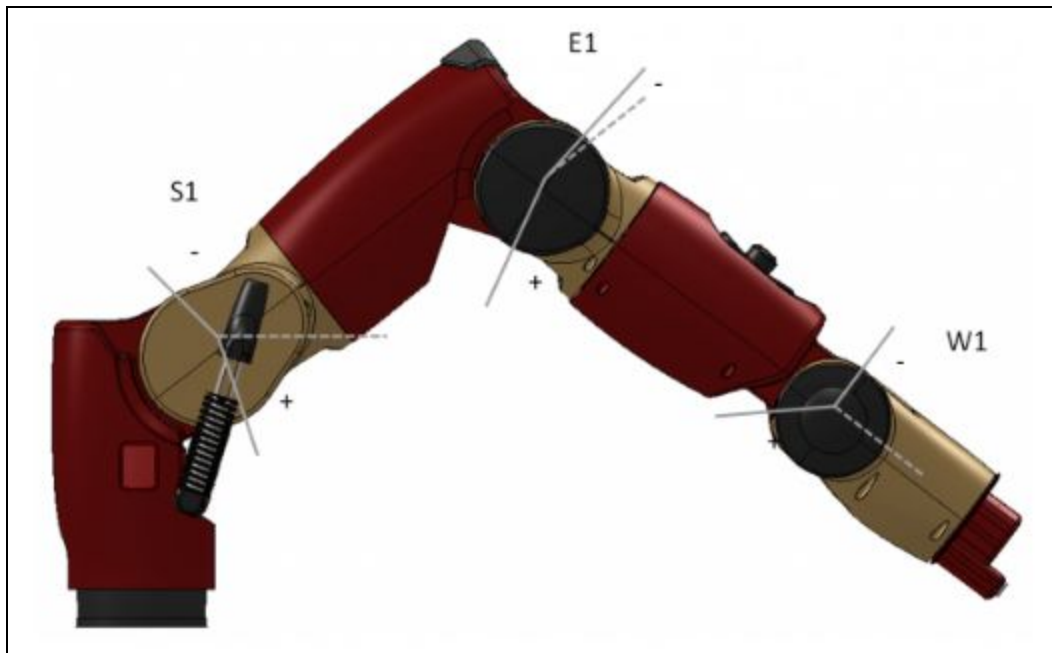

Figure 4.4: Zero Positions and Joint Limits for “Bend Joints” (Rethink Robotics, 2015)

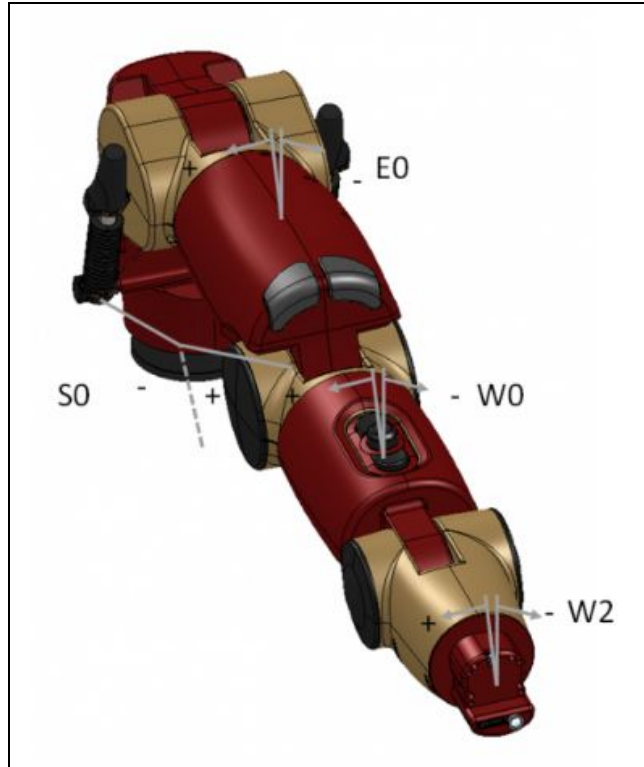

Figure 4.5: Zero Positions and Joint Limits for “Twist Joints” (Rethink Robotics, 2015)

### Active Puppet Arm Angle Sensing

The active RoboPuppet uses hall effect absolute encoders for joint angle sensing. Despite a cost increase, there were several key reasons for the change, and a few barriers that had to be overcome for the implementation. The reasons are consolidated in the table below:

<p><b>Benefits:</b></p> <ul style="list-style-type: none"> <li>• No direct mechanical linkage. On the passive arm, the coupler that attaches to the potentiometer can wear out and cause slippage.</li> <li>• Increased resolution. The encoders have an integrated 14 - bit sigma delta</li> </ul>	<p><b>Additional Challenges:</b></p> <ul style="list-style-type: none"> <li>• Increased cost. The Hall effect encoders cost between \$15 and \$19 per unit. This is two orders of magnitude greater than potentiometers</li> <li>• Larger form factor. The development boards that contain the hall effect</li> </ul>
---	---

analog-to-digital converter. This is a higher resolution than the onboard analog to digital converters that would be implemented on any of the microcontrollers (only 10 or 12 bit)

- Lack of a dead zone. The potentiometers have a deadzone of about 20 degrees at the extremes. In the dead zone, the wiper rotates without a change in signal. The hall effect encoders do not have this issue as the magnetic field will always vary when the angle varies.
- Digital communication. Because the angle is transmitted over a digital I2C signal, it is significantly more robust to noise and interference. The wires leading to some joints can be in excess of 4 feet long, which is of particular concern for reducing noise.
- Common bus. The I2C protocol that the encoders communicate to the microcontroller with, allows data lines to be shared by using an addressing system. This reduces the number of wires necessary for the system.
- Improved failure mode. Due to a mechanical linkage to the potentiometer wiper, there is a change that a bending moment could force the wiper of the resistive material. This would result in a near instant change to one of the extreme angles. The value would be sent to Baxter, which would attempt to quickly move to that position, and without quality filtering, could cause a jerk in Baxter's motion.
- Unlimited Range of Motion. Because there is no direct mechanical coupling between the magnet and sensor, the sensor can rotate to any angle. Whereas the potentiometers are limited to 270 degrees, less the dead zones.

sensor are considerably larger than the potentiometers. In addition, its sharp corners protruded into the adjoining link that forced the introduction of some complicated features in the links.

- Need to write control byte. The I2C protocol uses a command byte sent by the master to tell a certain slave device that it should be listening. The encoders need to have a burn in procedure to set this byte before they can be used.
- More wires. Each hall effect encoder requires 7 wires, whereas the potentiometers require 3

In order to ensure that the hall effect encoders properly work, a fixture was made to contain a hall effect sensor, and a magnet in the correct orientation. Fixture is effectively the first joint of the Active Robopuppet. Electrically, an Arduino Uno was used to read data off of and communicate to the sensor. Figure 4.6 is an overview of the testing setup.

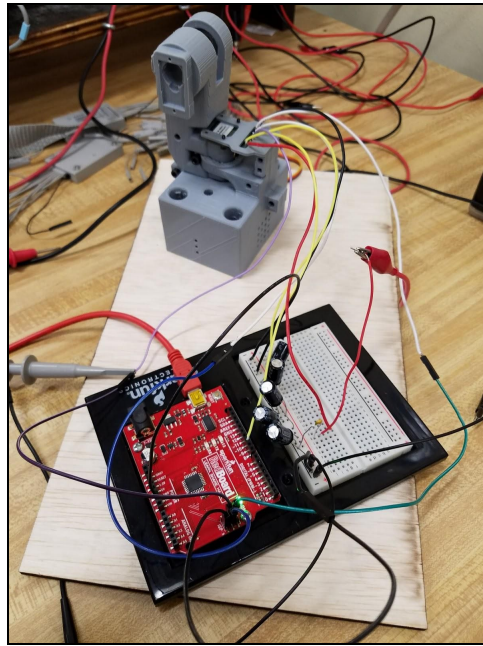

Figure 4.6: Testing setup for hall effect encoders

The testing procedure involved a couple of steps. Note that it is necessary to electrically isolate the microcontroller from the rest of the hall effect encoder circuit when the microcontroller being programmed. This is to prevent inadvertent communication of the I<sup>2</sup>C bus to the hall effect encoder. Some of programs are designed to permanently burn the fuses on the hall effect encoders and is critical to only run when intended. The procedure is as follows:

1. Run the program to set the control byte on the encoder board. A specific register address is used to initiate the burn in procedure
2. Run the program to verify the control byte value

3. Run the program to read off values from the encoder to successful operation

Once the encoders have been burned in, they are installed in the active RoboPuppet as seen in figures 4.7 and 4.8

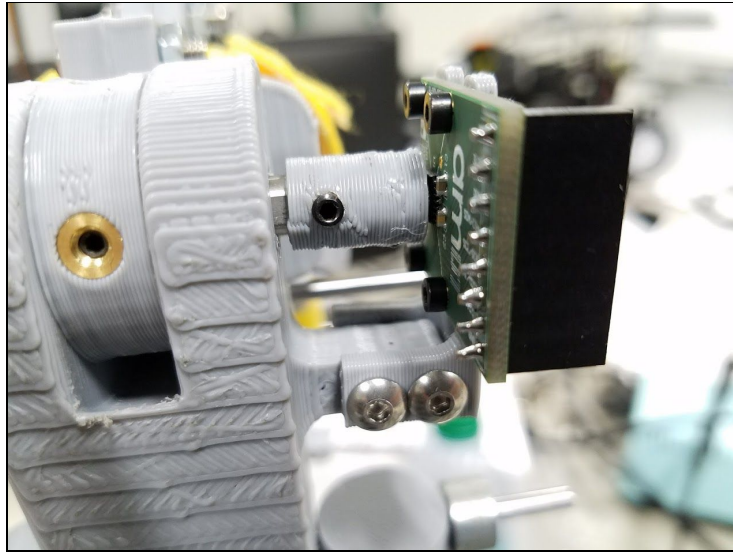

Figure 4.7: Mounting of Hall Effect Encoder on S1 Joint

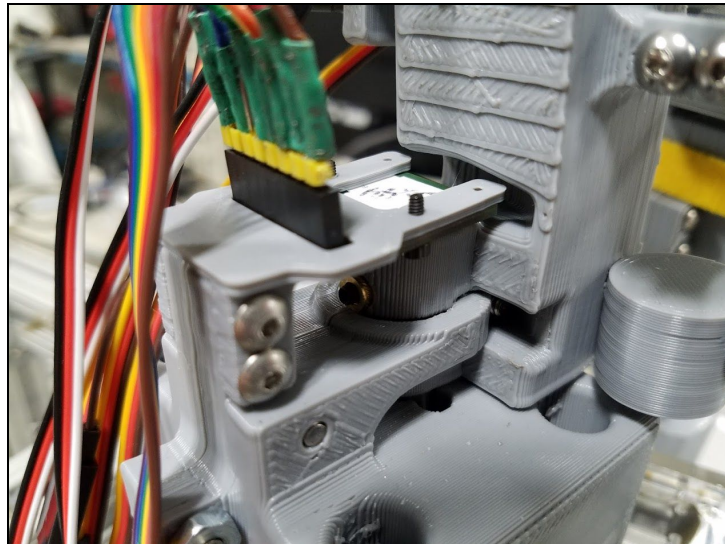

Figure 4.8: Mounting of Hall Effect Encoder on S0 Joint



## Actuator Signal Driving

Digital continuous rotation servo motors were selected as the joint actuator for their power, compact size, and ease of control. The TowerPro MG90D motors require a 5V supply voltage and a PWM driving signal. With a grounding connection, they form a common 3 pin servo connection.

## Supply Rail

As the device is a prototype, the system can be powered off a laboratory power supply. Through observation, it was determined that the servos draw 0.4A when stalled at full voltage. This is a worse case scenario as the servos produced too much torque, so the power would be reduced. Using a factor of safety of 1.2, and a total of 14 servos, the current and power requirements can be calculated with equations 4.1 and 4.2 below.

$$i_{total} = N_{servos} * FS * i_{single} = 14 * 1.2 * 0.4A = 6.72A \quad (4.1)$$

$$P = V * i_{total} = 5V * 6.72A = 33.6W \quad (4.2)$$

This truly represents a worst case scenario as it is unlikely that both arms will need to provide the maximum amount of feedback on all seven joints. Given the non-trivial amount of current, the standard practice of breadboards and 28 AWG wire cannot be used. Protoboards were used to mount the motors. The power lines transmitting voltage from the power supply to the breadboard, which has to carry the current of all 14 servo motors, is 18 awg copper wire. The wire is rated for 7.5A continuous, so it safely satisfies the current requirements even in the worst case scenario.

Note that this current is between the two standard current ratings for 18 AWG wire of chassis wiring and power transmission. As only a pair of wires will be used and they will be dangling in relatively open air, it is acceptable to assume the wire can perform closer to the higher end of the wire's current carrying capabilities of 16 A.

## Microcontroller Signal

The Towerpro MG90d is a servo motor. The servo is controlled using a PWM signal. Two different libraries exist within the Arduino library for generating PWM signals. The Servo.h library is used for controlling position servos. When that library is used, the write method causes the servo to go to a particular angle, and apply a holding torque. Internally, the servo contains a 360 degree potentiometer to measure absolute position. Care was taken by the designers to ensure that a short circuit would not occur at the overflow point, allowing the servo to rotate continuously.

The way to generate a PWM waveform with the Arduino library is the analogWrite method. This method generates a variable duty cycle pwm waveform. There is 8 bits of resolution on the duty cycle. Interestingly, when this approach is taken, the servo behaves as a velocity controlled servo (acting essentially as a standard DC motor). Since it is desirable to apply a specific torque rather than reach a specific position, the velocity controlled servo capability is more desirable for this application.

## Wiring and Wire Management

Wire management is an important consideration for the electrical subsystem. Besides aesthetics, it is relevant to increase clarity of what the wires connect to (and therefore make debugging easier), improve airflow, and prevent wires along the arms from getting caught and restricting motion. On virtually all commercial robot arms, the wiring is kept internal. However, the small arms of the robopuppet lack the cross sectional area necessary to have voids to run wires along. Therefore it was necessary to run the wires externally along the arms, and utilize cable ties to keep them neat and along the links. Care was taken to ensure that the wires were not too tight, as that could restrict the range of motion in the arms. However, it is prudent to not have the wires arranged too loosely, as the dangling wires can catch on other components. Figure X shows the compromise taken to ensure good maintenance of the servo motor wires on the active robopuppet.

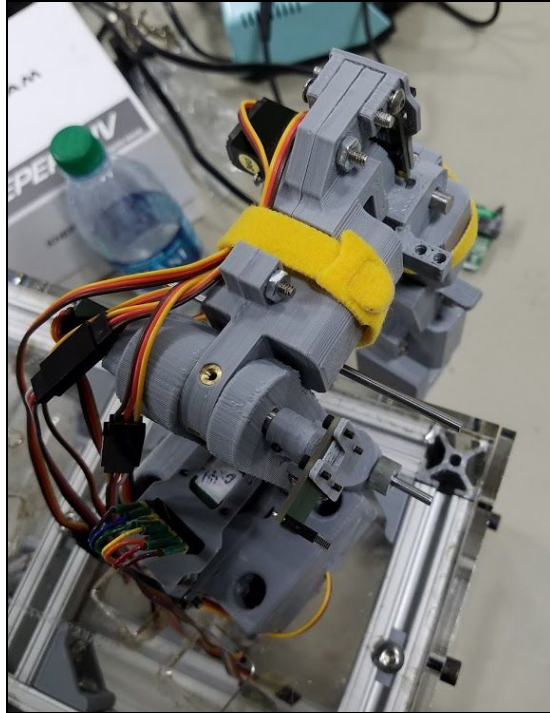

Figure 4.9: Motor wire management on active

The data line, clock line, 5V rail, 3V3 rail, and ground lines are all common. However the two pins for configuring the 2 least significant bits of the address need to be either grounded or pulled high. One idea to reduce the number of wires is to daisy-chain the hall effect encoder wires. The end goal would be to have a single 7-conductor ribbon cable for each arm. However, given the physical interface with the encoder boards, it is not feasible to have 2 sets of wires going to each port. So individual 7 conductor ribbon cables were wired to each encoder.

Three methods were investigated for physically containing the circuits: breadboards, solder-boards (protoboards) and printed circuit boards (PCB's). Breadboards were mainly used for their fast development time, given that no tools are needed. However, the wires are not as robustly attached to the board as a soldered solution, and on occasion, wires became

disconnected. Additionally, a previous iteration of the passive arm had a breadboard mounted on the side. This caused the backing to delaminate and remove some of the conducting pins along with it. This was a result of long term shearing and not a sudden shock damage.

In between the near instant development speed of breadboards and the professional appeal of PCB's, are solder boards. They are grid matrices of tinned holes that allow wires and components to be firmly soldered in, and traces connecting. The practice of laying down traces to connect pins turned out to be problematic. For the hall effect encoders, it was necessary to lay down 5 parallel traces across 7 connectors with additional traces for the control byte jumpers. The dense cluster of soldering turned out to be infeasible and not worth any gains in robustness over breadboards.

PCB's were considered the most ideal option as they are the archetype used in all consumer electronics. However there would be a significant time period to develop the circuit designs and verify that they will work, on top of the lead time and cost to produce. Given the objective simplicity of the custom circuits used, the PCB option was not seriously pursued. However, it is a consideration for later iterations looking to improve the professionalism and durability of the RoboPuppet.

## Microcontroller Selection

A system-on-a-chip microcontroller is used on all of the robopuppet to handle the low level sensor reading, transmission to the TRINA stack, and haptic control algorithms (in the case of the active RoboPuppet). Several key specifications were considered when selected microcontrollers for the active and passive RoboPuppets. Though none of the tasks were overly

processor or memory heavy, a number of microcontrollers were ruled out as they were deemed to be too low-powered to reliably satisfy the requirements. The most important considerations were the number of analog inputs and outputs, the number of PWM outputs, the presence and number of I<sup>2</sup>C busses, and the ability to send data to a PC in real time. Ease of use was also a consideration. In particular, the availability of libraries for tasks such as serial communication and I<sup>2</sup>C connection was considered.

For the passive RoboPuppet, an Arduino Mega 2560 Rev3 was selected. Though not as powerful or compact as other microcontrollers, this board satisfied the connection and processing needs, and was readily available. In addition, the Arduino family of microcontrollers are extremely well supported, both by the manufacturer and by open source software. For the active RoboPuppet, a Teensy 3.6 board was selected. This microcontroller offers more processing power, as well as four I<sup>2</sup>C busses (compared to one on the Mega). The extra busses mean that each arm can be controlled on a separate bus. In addition, the Teensy is more compact than the Mega and can connect directly to a breadboard or protoboard.

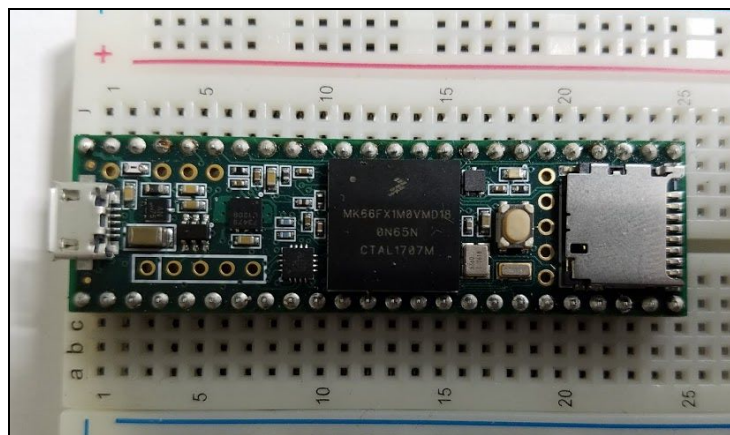

Figure 4.10 Teensy 3.6 Connected to a Breadboard

## Dead Man Switch

A high level design requirement for both the passive and active RoboPuppets is to have a means to disengage control of TRINA if the operator needs to take a rest or if a sudden event causes them to release the puppet. A dead man switch was selected due to its prevalence in other applications, including industrial machine tools, and train conductor consoles. A dead-man switch is a floor mounted switch that must be depressed in order for the machine to operate. If the user lets go of the peddle, either intentionally or in an emergency, the TRINA system shall cease motion and not respond to input from the RoboPuppet. In the active RoboPuppet, an addition feature was designed to lock the puppet arms to the same pose as Baxter, using the integrated motors. This is to ensure that when operation resumes, the puppet pose will accurately reflect what will be performed by Baxter.

# Software and Control Design and Analysis

## High Level Overview

The software for the RoboPuppet controller is split into two major sections: the Python code running on the PC and the C++ code running on the microcontroller. The microcontroller calculates the current joint angles and transmits them to the PC over a USB UART connection. The Python code is tasked with receiving this data and passing it into the TRINA stack, which in turn controls the physical or simulated TRINA robot. The process is illustrated in Figure 5.1 below:

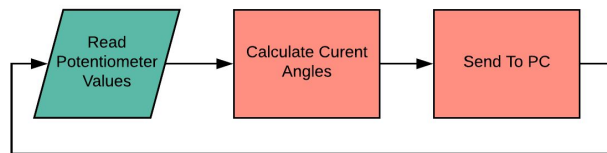

Figure 5.1: TRINA Stack Process

For the active RoboPuppet, the software will operate in a similar manner, but will include the ability to send feedback from the robot to the microcontroller. This feedback, in the form of the current joint angles of the robot, is used to determine the torque desired for haptic feedback.

Figure 5.2 below illustrates that data that will be passed between each device in the system

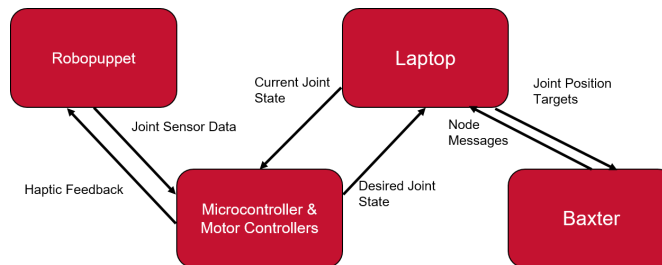

Figure 5.2: Active RoboPuppet Software Strategy



## Passive RoboPuppet Software Architecture

The software for the passive RoboPuppet is fairly straightforward. The Microcontroller code, at a high level, does three things: reading the values of the potentiometers, calculating the actual joint angles from those values, and sending those angles to the PC. Because the angle sensors for passive are analog potentiometers, the microcontroller software simply uses the `analogRead` function from the Arduino library to read the value. The angles are calculated from these values using calibration data that is hardcoded into a header file. The angles are organized into a struct containing 14 floats for the angles and 2 longs (on an Arduino, the long data type is the same size as the int data type is on the PC) for the gripper states. Once the values are properly stored, the entire struct is transmitted to the PC using the standard Arduino serial library.

The microcontroller code is also responsible for engaging and disengaging the robot. The user indicates that they want the RoboPuppet to actively control the robot by stepping on a foot pedal. When this pedal is disengaged, the microcontroller will continue to send the most recent “safe” angles until the pedal is reengaged. On startup, the angles default to 0, which correlates to TRINA’s limbs parallel to the floor.

In order to smooth the motion of the robot and remove any oscillations caused by a user’s shaking hands, a number of filtering techniques were discussed during the planning stages. These methods ranged from a simple moving average filter to more complex Kalman filtering. After initial testing, however, it was determined that any oscillations caused by the user were

made negligible by the slow speed of the robot. Neither the physical nor simulated robot were responsive enough to be affected by high frequency oscillations in the target joint angles.

The Python script running on the PC receives the struct containing the joint angle data before using the `unpack` function from the `struct` library to break it into a tuple containing usable data. At this point, the script passes the desired angles to TRINA. Rather than directly controlling the robot, the Python script is written as a plugin for the TRINA stack. This means that the script simply has to package the joint angles into a task message (a data type similar to a struct and defined by the TRINA stack) and pass this into the stack. The rest of the control is handled by the lower level software. The script is capable of identifying and connecting to an Arduino connected to any USB port on the PC, and has a limited ability to recover if the Arduino is connected after the script has been launched.

## Active RoboPuppet Software Architecture

The software for the active RoboPuppet will take the software for the passive device and expand it to include feedback from the robot. The differences in the hardware design between passive and active will also necessitate a handful of changes in the microcontroller code. In particular, the analog potentiometers have been replaced with digital Hall Effect encoders. This requires the microcontroller to connect to them using the I<sup>2</sup>C protocol, instantiated using the default libraries from Arduino. The microcontroller will also be responsible for implementing gravity compensation. This can be done without additional information from the PC, as it only requires the current joint positions of the RoboPuppet and information about their lengths and weight. When the foot pedal (see *Passive Software Architecture*) is disengaged, the active

RoboPuppet will not only transmit the previous joint angles, but will physically lock the RoboPuppet in place. This will be implemented with a Proportional Integral Derivative (PID) controller holding the RoboPuppet in its most recent position until the pedal is reengaged. The Python script for the active RoboPuppet also builds upon the script for passive, adding the ability to read the current joint positions of TRINA and pass these to the microcontrollers.

## Gravity Compensation Controller Policy

Two gravity compensation controller policies were idealized. The first is a simple PID approach, and the second is a more robust, but difficult to implement, dynamic model based design. The first method only seeks to keep the arm locked when the deadman switch is released. The approach would be to capture the puppet joint state when the pedal is released, and run a positional PID controller to maintain that position, using the RoboPuppet's hall effect encoders as feedback sensors. The positions will also cease being transmitted to TRINA. This technique has an advantage over the passive RoboPuppet deadman switch implementation that will keep the puppet in the same locked pose as Baxter, thus improving safety upon startup. A further step, in the event of a serious discontinuity between the puppet and Baxter, would be to use the RoboPuppet as a robot arm, as it effectively is one, to move to Baxter's pose and resume parity.

For the dynamic model based approach, the equations are derived by using the Euler-Lagrange formulation equations in non-equilibrium form, where the Puppet arms' transient response is equal to the applied motor torques  $\tau$ , and the manifestation of external forces on the end effector  $F_e$ .  $J$  is the manipulator Jacobian,  $M$  is the inertia tensor,  $C$  is the coriolis vector,  $G$  is

the gravitational vector, and  $q$  is the joint state. Equation 5.1 shows the original formulation. All vector quantities are indicated with bars.

$$\bar{\tau} + J^T \bar{F} = M\bar{q}'' + C(\bar{q}, \bar{q}') + G(\bar{q}) \quad (5.1)$$

The first step to implementing the gravity compensation is to determine the exact lengths, weights, and inertias of each joint. It is important that these values include everything that will be attached to the robot during operation, such as the gripper modules, wires, and cable ties used for wire management. Most CAD softwares are capable of providing a reasonably precise numerical calculation of the mass, center of mass, and moment of inertia, provided that the model is extremely detailed and accurate.

Assuming that the speed that the arms will be moving is quite slow, the inertial and Coriolis forces can be neglected. Further discussion on the model based gravity compensation, is continued after the introduction of the haptic feedback scheme.

## Haptic Control Scheme

The Baxter robot is not capable of making very fast rapid motions such as the industrial articulated robot arms of ABB, Fanuc or Puma. The slow speed was an engineering design tradeoff to ensure that Baxter can operate safely around humans. However, given the relatively small size of the RoboPuppets, it is quite easy for the user to jostle the arms at higher speeds than the robot can output. Using the integrated actuators on the Active RoboPuppet, a haptic control policy is realized. This scheme is to run in addition to the gravity compensation scheme. The idea considered is classified as “soft” haptic feedback. The torque applied is in proportion of

the joint error. Equation 5.2 shows the torque calculation policy.  $K_H$  is a gain, and  $q$  refers to the measured joint angles of Baxter and the Puppet.

$$\tau = K_H * (\bar{q}_{Baxter} - \bar{q}_{Puppet}) \quad (5.2)$$

If the user move the arm very fast, a significant error will emerge and the controller will ideally compensate with a larger feedback torque. The goal is to train the user to the speed limits of Baxter, by repeated application of these resistive torques.

The “soft” haptic feedback scheme differentiates itself from a “rigid contact” haptic feedback scheme, where the torque is directly sensed from the joints of Baxter and transferred to the user. This rigid scheme has the advantage of better indicated when collisions occur. However this approach adds significant complication to the communication protocol. Ideally a 10 kilohertz outer control loop would need to be established in order to ensure that the transmission of torque feels “smooth” to the user (Fischer and Harrington, Personal Interview).

# Conclusions

## Testing

After manufacturing, each model was tested using a KLAMPT simulation of Baxter. The passive design was manufactured and tested first, so that results could bring insight to design of the active model. Additionally, individual components were tested before the full manufacturing of a model.

Before testing of the full passive model, the potentiometers were tested inside of each of the individual joints. This allowed for observation of the behaviour of the sensor output and calibrate each sensor individually.

When testing the passive design, there were four major concerns. These were, the durability of the puppet, user comfort when using the puppet, ease of using the puppet and accuracy between the puppet and simulation position. Durability was tested through observations of the mechanism during other tests. Any mechanical failures or weaknesses were documented. Comfort and ease of use results were obtained through objective reports from each team member while testing the device. The accuracy of the controller position was tested by roughly measuring the position of the mechanism and comparing this to the position of the simulated robot, as well as to the potentiometer outputs.

When testing the active design, the first shoulder joint was fabricated and assessed first. This allowed design errors and manufacturing difficulties to be identified without committing the resources of a full arm to the test. While testing this joint, the main focuses were the behaviour of

the servo, the hall effect encoder sensor, and the durability of the design. The servo behaviour was tested by attempting to hold the link steady using the servo without user input. The sensor output was tested by having a user move the joint to various positions. The sensor output was compared to the known positions of the joints. The durability of the part was observed throughout these tests and any mechanical failures were recorded.

## Performance

In general, the passive RoboPuppet was successful in controlling the robot, with some limiting factors. The RoboPuppet was able to accurately position the robot, however, the TRINA's slow operating speed meant that the RoboPuppet often became far out of sync with the physical robot. The RoboPuppet's workspace was slightly larger than the actual robot's, allowing it to utilize the entire workspace of TRINA. Though this generally made controlling the robot fairly easy it also allowed the user to position the RoboPuppet in a collision position or an otherwise unreachable pose. For the most part, however, these situations could be prevented by configuring the TRINA stack to only allow safe positions. The foot pedal system used to engage and disengage the RoboPuppet was also successfully implemented.

## Durability and Reliability

As the RoboPuppet device is intended for use by a non-technical operator who will likely lack the background necessary for repairs, durability and reliability will be major concern for a final product. Though the devices are prototypes, this was still a consideration in their design. In general, both versions of the RoboPuppet designed during this project were mechanically reliant

enough that very few major issues arose. Despite this, a number of recurring issues were apparent, mostly centered around the potentiometers used in the passive RoboPuppet. The pins on these potentiometers were designed for use in a breadboard but had to be soldered to for this project. This led to disconnects in the wiring causing errors. In addition, the plastic hubs on the servos could become stripped, leading to the potentiometers coming uncoupled from the rest of the joint. In this situation, the angle of the arm stops updating.

## Cost

The final cost of this project was \$742.80. Though this is well below our targeted cost for two puppets, it includes some extra materials and does not include the costs of 3D printing (which was provided by a Robotics Department lab). The estimate including 3D printing is that the passive RoboPuppet would cost approximately \$300 to construct while the active would cost closer to \$600. Both of these numbers are below our targets.

## Continuation

Though this project achieved a number of its objectives and made progress towards others, there is still quite a bit of room for future work. First and foremost is the completion of the active RoboPuppet. Though the hardware design has progressed to a usable state, and an arm has been constructed, there is still some refinement to be done on the design. One particular area of concern is the workspace of the RoboPuppet. Though it would likely still be sufficient to operate TRINA, the workspace is smaller than the actual robot. This could likely be improved by removing unnecessary material near the joints as well as other minor design improvements. A



further step would be to implement the software for the active RoboPuppet, including gravity compensation and haptic feedback.

Though the gripper devices designed during this project are effective, they provide binary control to the user, only allowing them to fully close or fully open the gripper. Implementing a new control method for the gripper that allows the user to set any position would make TRINA significantly easier to use by allowing gripper preshaping. In addition, only being able to control the gripper as a claw may be a limitation for operating certain machinery or completing certain tasks. Allowing the fingers of the gripper to be controlled individually would likely increase the user's ability to complete fine manipulation tasks, such as pressing buttons or opening a package.

Another important aspect of this research that wasn't feasible within the scope of this particular project is testing the controller on actual nursing tasks and with actual medical professionals. In particular, gathering data on the times to complete common nursing tasks and comparing it to the times taken by a traditional controller and a human will prove the effectiveness of the device and provide a better view of what improvements are needed in the future.

## References

1. Albritton, S. (2007, October). Using Robotic IV Preparation Devices to Improve Patient Safety and Workflow Efficiency. *Pharmacy Purchasing and Product Magazine*, 2-2.
2. American Nurses Association (n.d.). *The Nursing Process*. Retrieved from <https://www.nursingworld.org/practice-policy/workforce/what-is-nursing/the-nursing-process/> Retrieved September 25, 2017
3. Expertvillage. (2008, September 25). Retrieved April 25, 2018, from <https://www.youtube.com/watch?v=hAVCtWOLuD>
4. Goran, S. F. (2010). A Second Set of Eyes: An Introduction to Tele-ICU. *Critical Care Nurse*, 30(4), 46-55. doi:10.4037/ccn2010283
5. Grinnell, M., Dixon, M. G., Patton, M., Fitter, D., Bilivogui, P., Johnson, C., . . . Raghunathan, P. (2015). Ebola Virus Disease in Health Care Workers — Guinea, 2014. *MMWR. Morbidity and Mortality Weekly Report*, 64(38), 1083-1087. doi:10.15585/mmwr.mm6438a6
6. Hull, D. (2017, November 4). Baxter by Rethink Robotic [Www.msmanchester.org.uk/whats-on/robots]. Retrieved April 18, 2018, from <https://www.flickr.com/photos/dullhunk/38107566966>
7. Lampl, M. (2008). Basic Ergonomic Training. Safety Leader's Discussion Guide. Retrieved from <http://www.corvel.com/media/93096/BWC-SafetyTalk-Basicergo.pdf>
8. Li, Z., Moran, P., Dong, Q., Shaw, R. J., & Hauser, K. (2015). Development of a Tele-Nursing Mobile Manipulator for Remote Care-giving in Quarantine Areas [Scholarly project]. Retrieved September 15, 2017
9. Mayo Clinic, Office ergonomics: Your how-to guide. (2016, April 20). Retrieved from <https://www.mayoclinic.org/healthy-lifestyle/adult-health/in-depth/office-ergonomics/art-20046169>)
10. M. Pollack, S. Engberg, J.T. Matthews, Sebastian Thrun, L. Brown, D. Colbry, C. Orosz, B. Peintner, S. Ramakrishnan, J. Dunbar-Jacob, C. McCarthy, Michael Montemerlo, Joelle Pineau and Nicholas Roy(August, 2002). Pearl: A Mobile Robotic Assistant for the Elder, Workshop on Automation as Caregiver: the Role of Intelligent Technology in Elder Care (AAAI), Retrieved from <https://pdfs.semanticscholar.org/1bc1/535414684083ecef597f704bb069a6b6f38f.pdf>
11. Nurse Journal, (n.d.). 5 Responsibilities of a CNA Certified Nursing Assistant. Retrieved from <https://nursejournal.org/certified-nursing-assistant/certified-nursing-assistant-responsibilities/>, Retrieved September 18, 2017

12. Nurses' Working Conditions: Implications for Infectious Disease - Volume 10, Number 11-November 2004 - Emerging Infectious Disease journal - CDC. (2011, April 21). Retrieved from [https://wwwnc.cdc.gov/eid/article/10/11/04-0253\\_article](https://wwwnc.cdc.gov/eid/article/10/11/04-0253_article), Retrieved September 20, 2017
13. Park, T. M., Won, S. Y., Lee, S. R., & Sziebig, G. (2016). Force feedback based gripper control on a robotic arm. 2016 IEEE 20th Jubilee International Conference on Intelligent Engineering Systems (INES). doi:10.1109/ines.2016.7555102
14. Pratt, G., & Williamson, M. (1995). Series elastic actuators. Proceedings 1995 IEEE/RSJ International Conference on Intelligent Robots and Systems. Human Robot Interaction and Cooperative Robots. doi:10.1109/iros.1995.525827
15. Precision Microdrives, Making a Haptic Device. (n.d.). Retrieved from <https://www.precisionmicrodrives.com/haptic-feedback/making-a-haptic-device>
16. Qin, H., Song, A., Liu, Y., Jiang, G., & Zhou, B. (2015). Design and Calibration of a New 6 DOF Haptic Device. *Sensors*, 15(12), 31293-31313. doi:10.3390/s151229857
17. Rethink Robotics. (2015, October). *Collaborative Robotics Pioneer* [Press release]. Retrieved September 15, 2017, from [http://www.rethinkrobotics.com/wp-content/uploads/2015/11/Baxter\\_Datasheet\\_Oct2015.pdf](http://www.rethinkrobotics.com/wp-content/uploads/2015/11/Baxter_Datasheet_Oct2015.pdf)
18. Tedeschi, B. (2014, December 24). The Year in Robots: 10 Home Robots to Lighten Your Domestic Chores. NY Times. Retrieved from <https://www.nytimes.com/2014/12/25/garden/10-home-robots-to-lighten-your-domestic-chores.html?mcubz=0>, Retrieved October 4, 2017
19. Toyota Motor. (n.d.). Toyota Global Site | Partner Robot Family\_02. Retrieved from [http://www.toyota-global.com/innovation/partner\\_robot/family\\_2.html](http://www.toyota-global.com/innovation/partner_robot/family_2.html) Retrieved October 4, 2017
20. United States Department of Labor. *Ergonomics* (n.d.). Retrieved from <https://www.osha.gov/SLTC/ergonomics/>
21. Waldo (remote manipulator). (n.d.). Retrieved from [http://muppet.wikia.com/wiki/Waldo\\_\(remote\\_manipulator\)](http://muppet.wikia.com/wiki/Waldo_(remote_manipulator))

# Appendix I: Troubleshooting Guide

Below is a list of common problems as well as their likely causes and solutions. These issues have all been identified in the passive RoboPuppet, and while similar issues may arise in the active device, these solutions have not been tested for that version.

**Problem:** Arduino lights turn on properly but fade out shortly afterwards.

**Likely Cause:** A short in the wiring, most likely in one of the breadboards or potentiometers.

**Solution:** Removing and/or tracing wires until the short is found. Start by removing the power connections to each board and then systematically removing and replacing connections until the issue is found. It's very likely a short in one of the potentiometer connectors.

**Problem:** One of the joints isn't responding. The joint is NOT at an extreme.

**Likely Cause:** The potentiometer is slipping in the coupler. The set screw has come loose.

**Solution:** Disassemble the joint and re-tighten the set screw. Test to ensure that this fixed the problem before fully re-assembling.

**Problem:** One of the joints isn't responding. The joint is at an extreme.

**Likely Cause:** A short or disconnect in the potentiometer.

**Solution:** Check the potentiometer wiring to identify the short or disconnect. Use a multimeter connection test if possible. Re-solder or replace the potentiometer.

**Problem:** The Python script reports an exception (whether or not it crashes) that says something about having the wrong data or data format for the struct-unpack function.

**Likely Cause:** Wrong code being run on the Arduino.

**Solution:** Load the most recent code on the Arduino.

**Problem:** Python script reports that Arduino could not be connected.

**Likely Cause:** Multiple possible sources.

**Solution:** Confirm that Arduino is connected and that the lights are on. If problem continues, power cycle the Arduino.

**Problem:** Simulation freezes.

**Likely Cause:** Unknown

**Solution:** Restart simulation and TaskGUIDemo. If problem persists restart all TRINA Stack programs.

**Problem:** TaskGUIDemo freezes, but simulation does not.

**Likely Cause:** Arduino is not sending messages properly or messages are not being received properly

**Solution:** Ensure that Arduino is connected and loaded with proper code. Restart TaskGUIDemo.

## Appendix II: Bringup Instructions

These instructions are for starting up the TRINA stack with either the physical or simulated robot. They assume that the user is running Ubuntu 16 and has already installed ROS, Klampt, and the TRINA stack. For ease of use, it is highly recommended to use the Terminator terminal emulator, which supports multiple open terminals in the same window.

### For Simulated Robot:

- Start a ros core
- open four terminals under "~/iml-internal/Ebolabot" folder
- Switch to simulation mode by running  
\$ . switch\_to\_virtual.sh

This will change the setup in "Common/system\_config.json". Pay attention to,

```
"motion_computer_ip":"tcp://localhost:8001",  
"state_server_computer_ip":"tcp://localhost:4568",
```

- Run everything under the Ebolabot Path, which is "~/iml-internal/Ebolabot"

In each of the four terminals, run

```
== Terminal 1 :  
$ python Common/system_state_service.py
```

```
== Terminal 2:  
$ ./MotionServer_kinematic
```

```
== Terminal 3:  
$ ./ControllerDispatcher -v
```

This will start the simulation environment

```
== Terminal 4:
```

```
$ ./TaskGUIDemo
```

This will start the user interface (in the front). Make sure it is active so that you input signals will take effect. While the UI window is active, hit “m” to switch input modes.

## For Physical Robot:

- Make sure to use Ubuntu 16. For the lab desktop, on the TRINA account, the password is "motion"
- Switch to physical mode by running

```
$ . switch_to_physical.sh
```
- In each tab run `./baxter.sh` under the `ros_ws` directory
- to enable robot:

```
$ rosrn baxter_tools enable_robot.py -e
```
- to disable robot:

```
$ rosrn baxter_tools enable_robot.py -d
```

In each of the four terminals, run

== Terminal 1 :

```
$ python Common/system_state_service.py
```

== Terminal 2:

```
$ ./MotionServer_physical
```

== Terminal 3:

```
$ ./ControllerDispatcher
```

Unlike in simulation this will not launch a simulation window, but will instead prepare to control the physical robot.

== Terminal 4:

```
$ ./TaskGUIDemo
```

This will launch a UI similar to that from the simulation, but will control the physical robot rather than a simulation.

## Appendix III: CAD Models

This section contains Solidworks drawings of critical parts and assemblies of both the passive and active RoboPuppets

### Passive RoboPuppet CAD Models

Full Assembly Exploded View

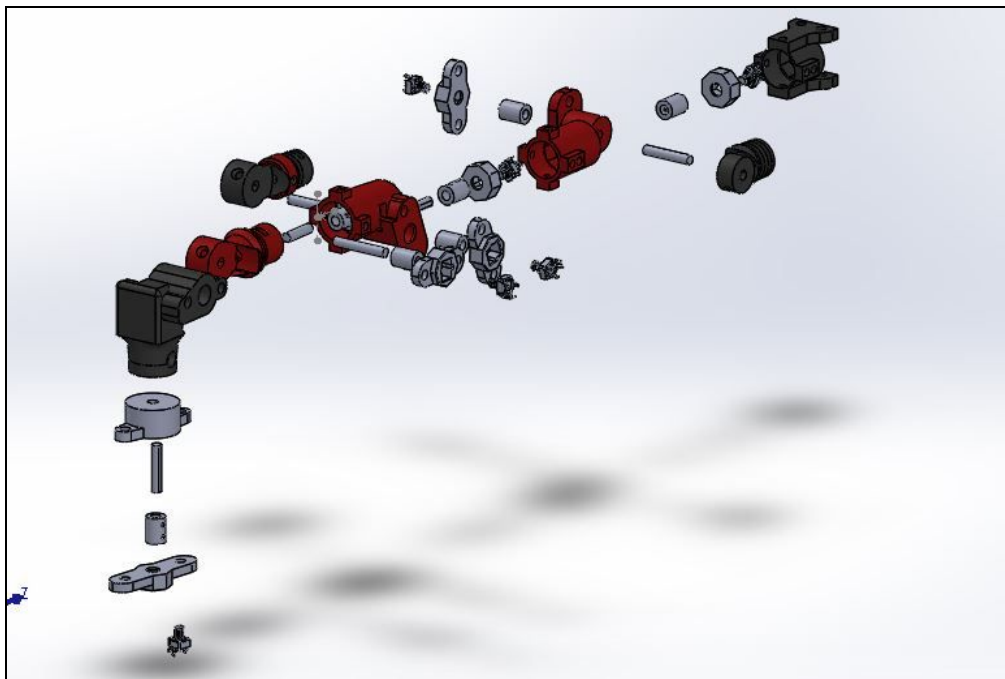



Model of Link with W0 and W1 joints

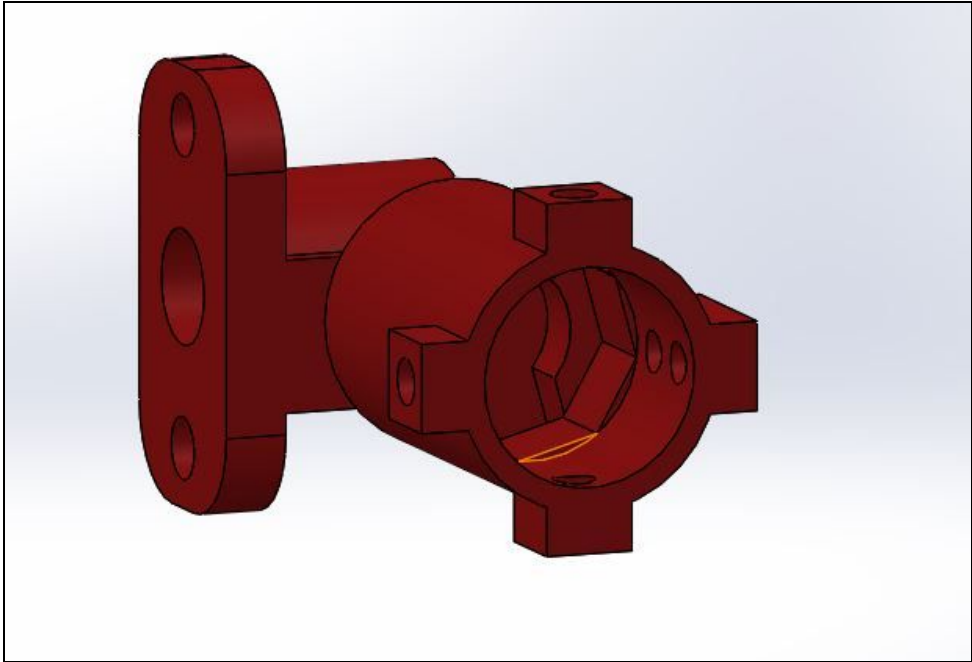

Common potentiometer assembly used in the S1, E1 and W1 joints

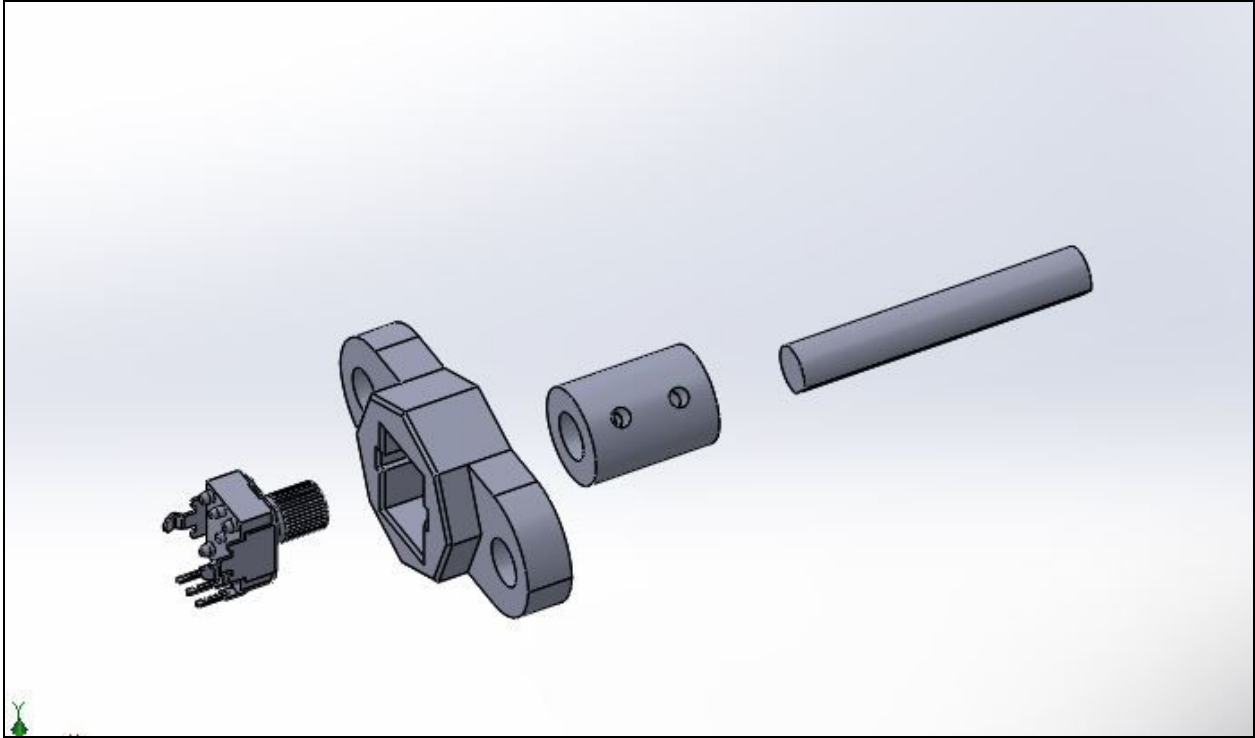

# Active RoboPuppet CAD Models

## Full RoboPuppet Assembly

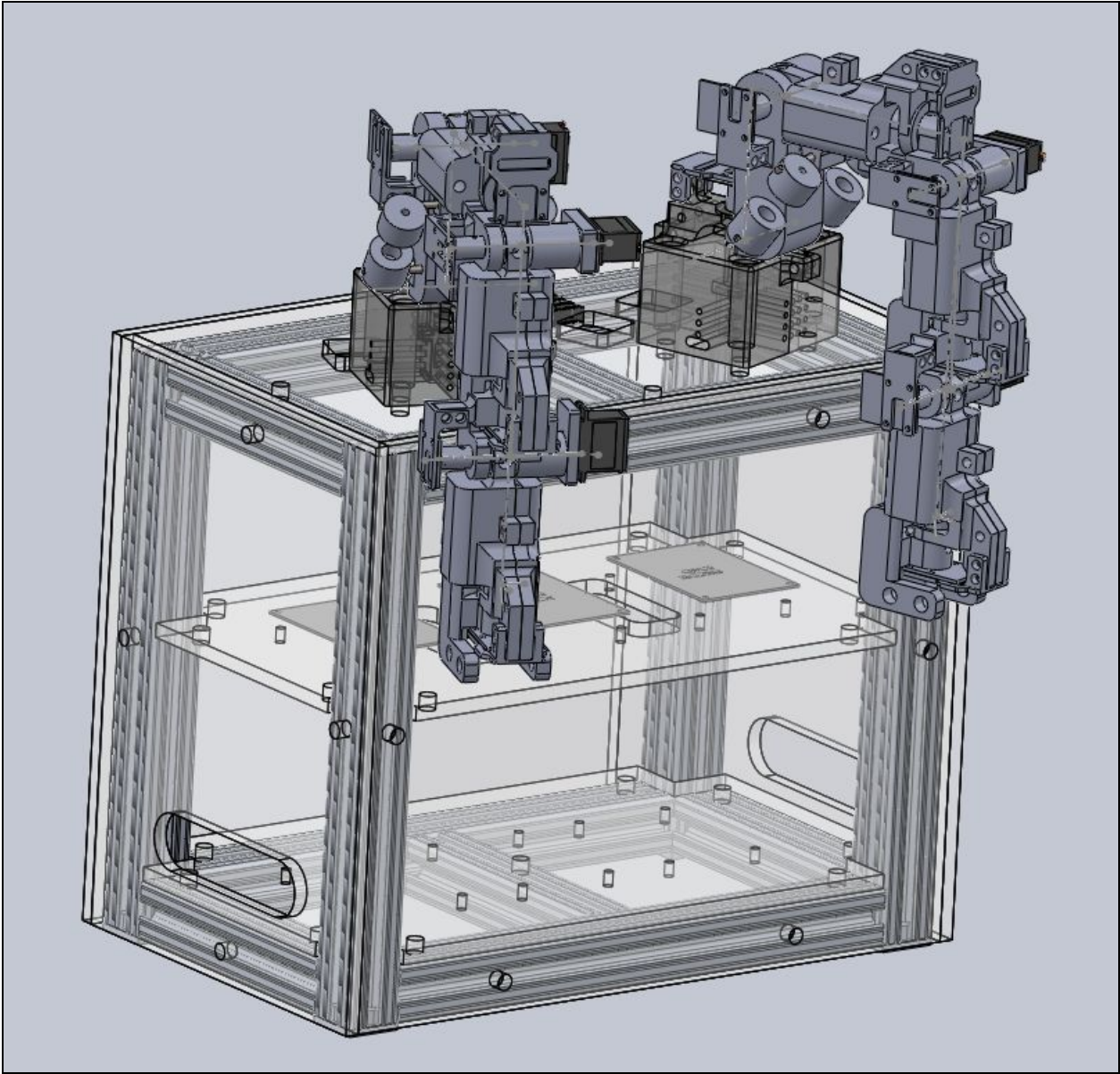

Full Arm Assembly

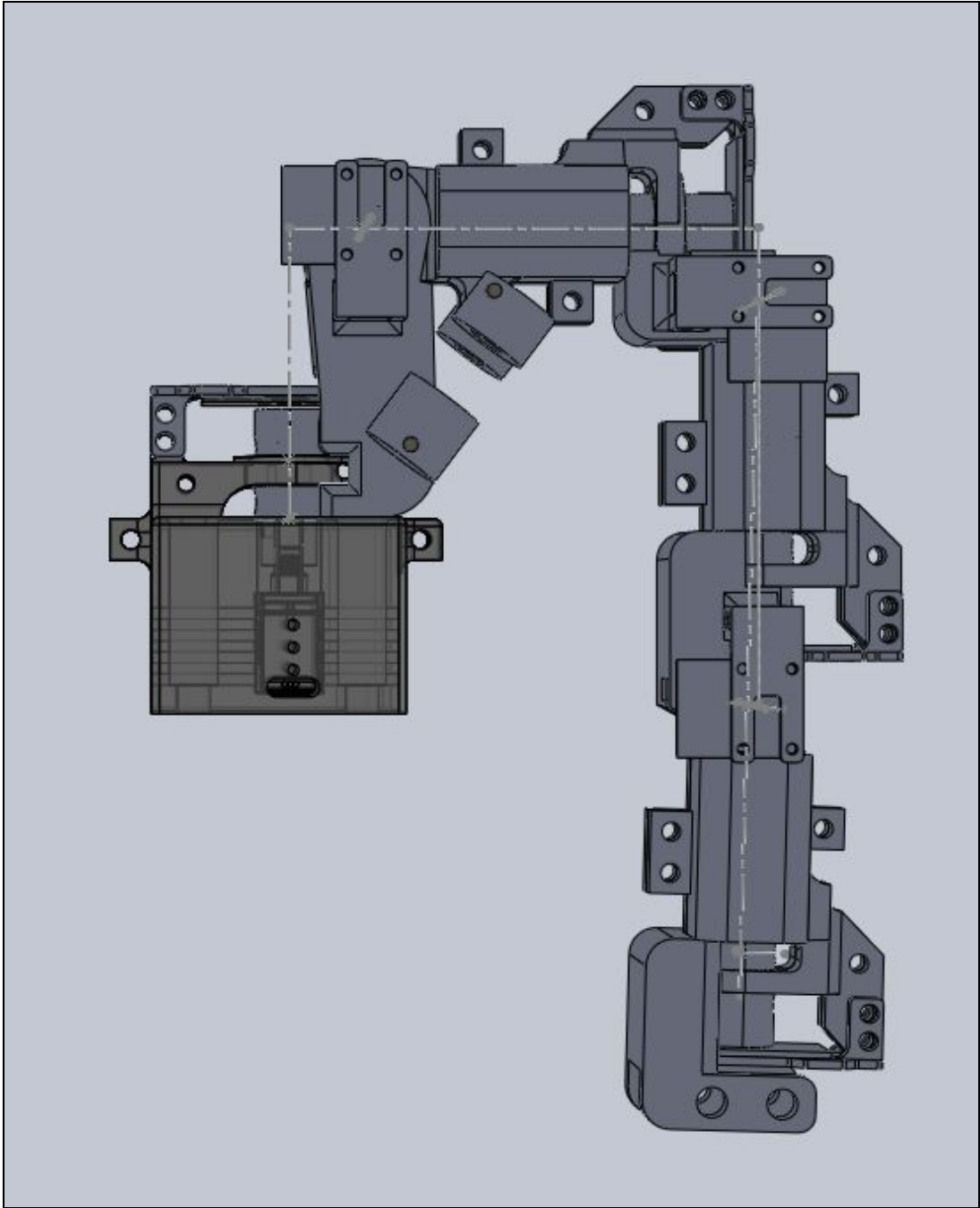

Exploded View of E0 and E1 joints

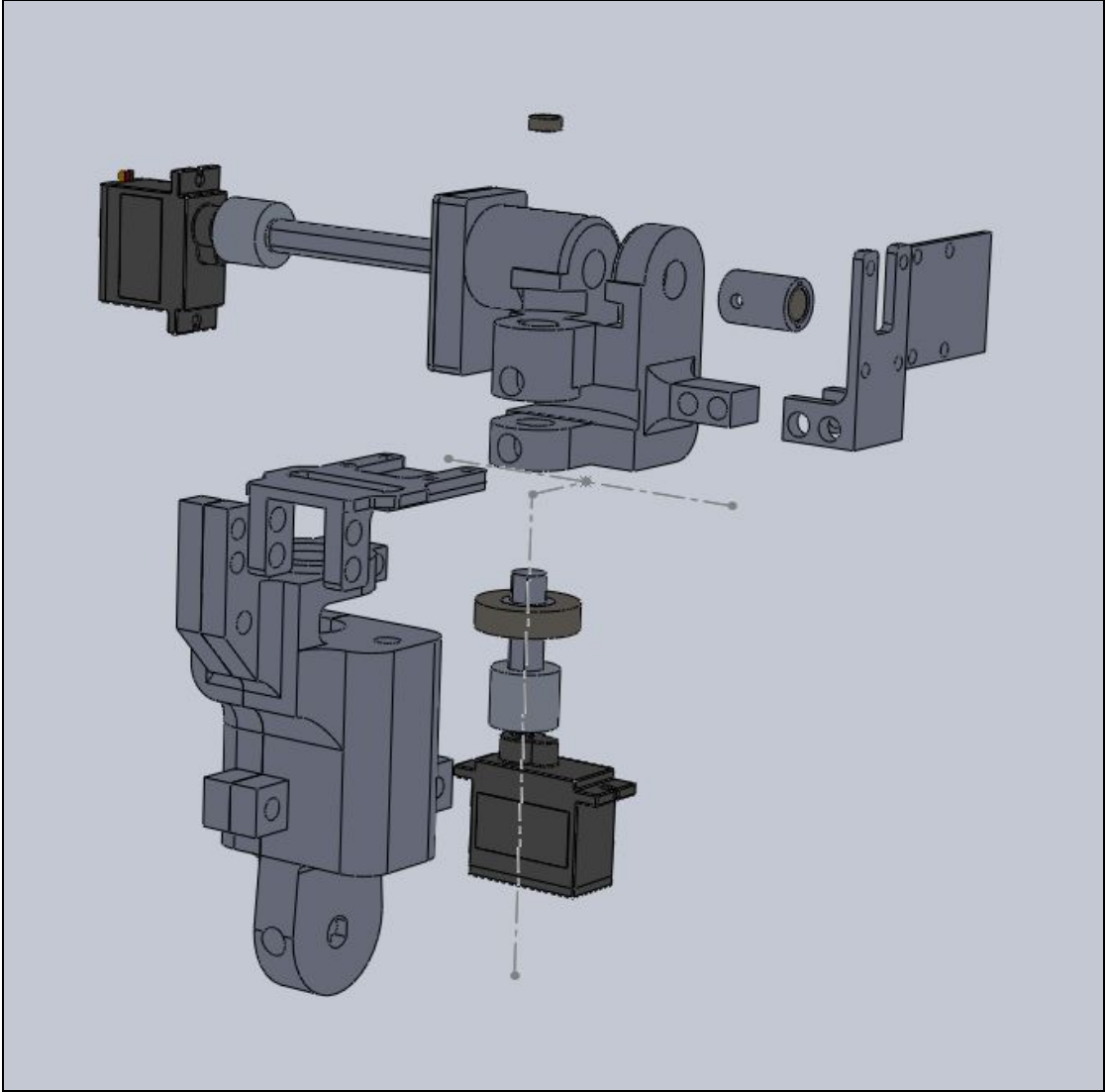

DH Parameter Wireframe

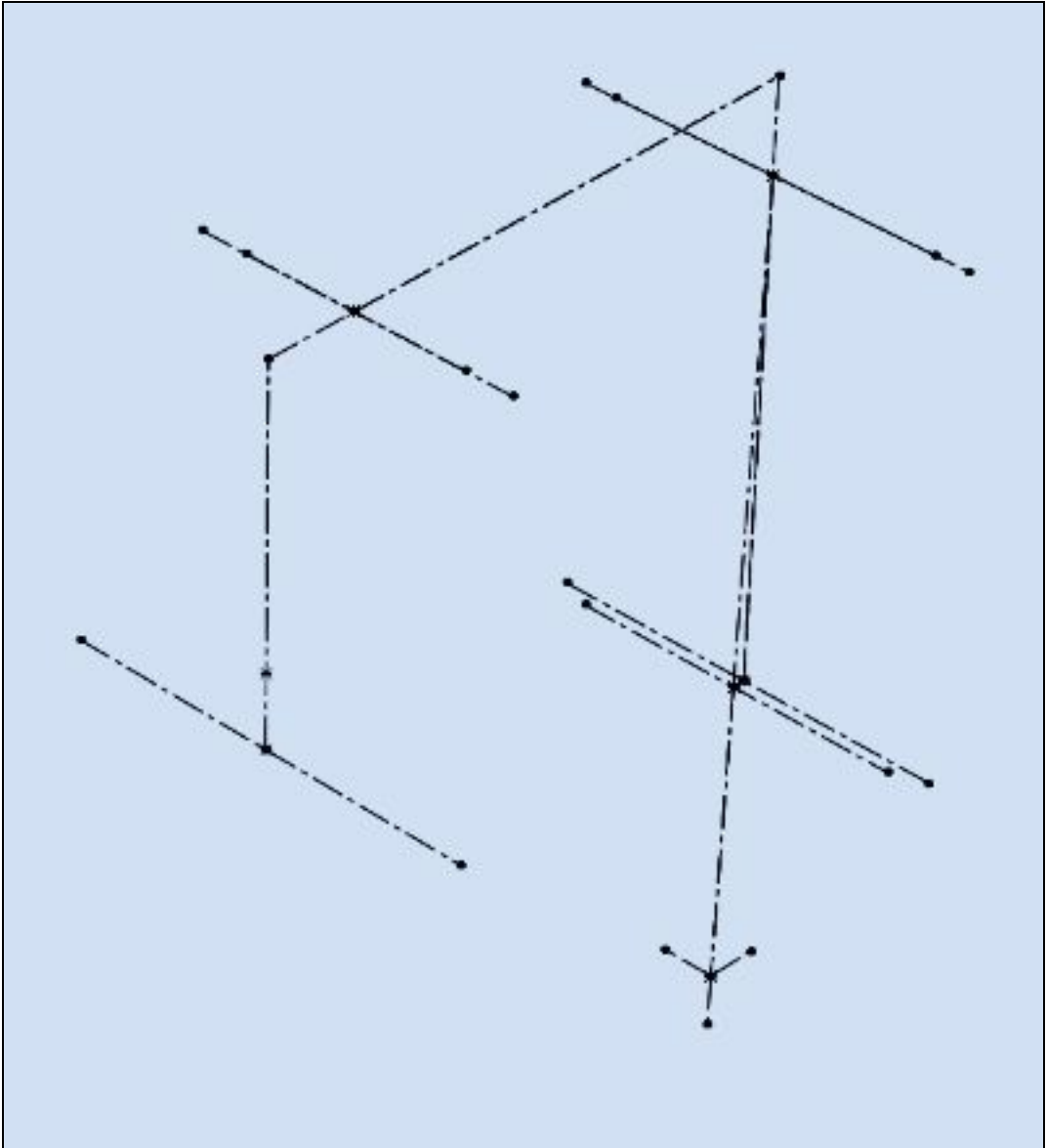

# Appendix IV: Torque Calculations

It was necessary to acquire actuators that could apply sufficient joint torque in order to perform gravity compensation. This spreadsheet is used to calculate the worst case scenario torque that is applied to each joint. The assumptions were made that the arm is fully cantilevered in the worst case scenario, that each joint would use the same motor, and that the s1 joint would have the highest torque needed for gravity compensation. The spreadsheet calculates the mass of each link as a function of its geometry, scale to Baxter, and part density. The number generated by this spreadsheet was used as a constraint

	A	B	C	D	E	F	G	H	I	J
1	Link Number	0	1	2	3	4	5	6		
2	Link Length Lengths(mm)	15	60.75	26.298	48.915	28.429	56.457	45.784		
3	Total Length(mm)	130.67								
4	Part Volume (mm^3)	10402.73	49070.31	11259.48	35677.12	9412.62	23128.79	12013.83		
5	Scaling Factor	1.5								
6	Scaled Volume	35109.21375	165612.3	38000.75	120410.3	31767.59	78059.66	40546.68		
7	Part Mass(kg)	0.036864674	0.173893	0.039901	0.126431	0.033356	0.081963	0.042574		
8	Part Weight(N)	0.361273809	1.704151	0.391028	1.239022	0.326889	0.803234	0.417225		
9	Total Weight(N)	1.547347758								
10	Part Weight(lbf)	0.081217604	0.383108	0.087907	0.278543	0.073487	0.180574	0.093796		
11	motor length(mm)									
12	Motor mass(kg)	0.013								
13	Motor Weight(N)	0.1274								
14	Motor Weight(lb)	0.02866006								
15										
16										
17										
18	Torque needed(N*mm)	167.8656633								
19	Torque needed(oz*in)	23.77178038								
20	motor operating torque									