

# Linear Heat Detection Placement

A Major Qualifying Project Report  
Submitted to the Faculty of  
WORCESTER POLYTECHNIC INSTITUTE  
in partial fulfillment of the requirements for the  
Degree of Bachelor of Science

By:

Tyler Faszewski

---

In Collaboration with Shanghai Jiao Tong University  
Partners: Liaoyuan Zhao and Song Chen

Approved:  
Professor Nicholas A. Dembsey

---

Melissa Avila, Engineering Manager, Tyco Fire Protection Products

---

Project Number: NAD TY13

## **Abstract**

Linear heat detection (LHD) has become an integral part of protecting people and property in structures such as storage facilities, tunnels, and subways. It makes for an ideal heat detector due to its chemical resistance, ability to detect fire anywhere along its length, and cost effectiveness. The National Fire Protection Association (NFPA) has set requirements concerning the installation of LHD. According to NFPA 72, LHD must be no more than 50.8 cm (20 in.) from the ceiling. The standard requirement applies to only flat ceilings and is not affected by the total ceiling height. In the current work, hand calculations, tests, and simulations were conducted to understand if the 50.8 cm (20 in.) depth is an acceptable requirement in the context of general fire behavior under flat ceilings.

## **Acknowledgements**

We would like to thank our advisor Professor Nicholas Dembsey for his timely input, advice and revisions. His advice will be something we remember going into our professional careers. We would also like to thank Melissa Avila and Madhura Karve at Tyco for their input and advice regarding testing and simulations. Without their help neither our tests nor simulations would have been as effective as we were collecting the necessary data. Also, we would like to thank Joe Schindler and Jake Dube for their help and efforts regarding data collection and test set ups. Without their help and supervision our tests would not have been completed in a timely manner. Finally we would like thank Tyco Fire Protection Products for the use of their fire testing space and funding for the project, without which none of the research would have been possible.

## Table of Contents

Abstract.....	2
Acknowledgements.....	3
List of Figures.....	6
List of Tables.....	7
Chapter 1: Organization.....	8
Chapter 2: Conference Paper.....	9
Introduction.....	9
Test Details.....	9
Equipment.....	10
Uncertainties.....	12
Test results.....	13
Repeatability.....	16
Analysis.....	17
FDS Simulation Results.....	18
Comparison to Previous Work.....	20
Boundary Layer Thickness.....	21
Thermal Thickness.....	22
Highest Temperature Calculation.....	23
Literature Profiles.....	25
Conclusion.....	26
Test Results.....	26
FDS Simulation Results.....	26
Scaling.....	27
Thermal Thickness.....	27
Installation Suggestions:.....	28
Works Referenced.....	30
Appendix A: Ceiling Jet.....	32
Appendix B: FDS Report.....	43
Appendix C: LHD Installation Guide.....	56
Appendix D: Test Plan.....	60
Appendix E: LabVIEW.....	67
Appendix F: Thermocouples.....	70

Appendix E: Test Results.....	71
Appendix H: Final Presentation.....	77
Appendix I: FDS Input Files.....	102
Appendix J: Future Work.....	134

## List of Figures

Figure 1 Test 1 & 2 Temperature Profiles.....	14
Figure 2 Ceiling Jet Profile.....	17
Figure 3 0.76m (2.5 ft.) FDS & Test Temperature Profile.....	20
Figure 4 1.37m (4.5 ft.) FDS & Test Temperature Profile.....	20
Figure 5 1.98m (6.5 ft.) FDS & Test Temperature Profile.....	21
Figure 6 2.59m (8.5 ft.) FDS & Test Temperature Profile.....	21
Figure 7 Boundary Layer Comparisons for 2.44 m (8 ft.) Ceiling Height.....	22
Figure 8 Thermal Thickness Comparison.....	24
Figure 9 Highest Temperature Comparison.....	25
Figure 10 Comparison of Motevalli & Test Temperature Profile.....	26
Figure 11 Thermal Thicknesses for Different Ceiling Heights.....	29
Figure 12 Fire Diagram.....	34
Figure 13 Ceiling Jet Diagram.....	35
Figure 14 HRR for Ceiling Heights.....	39
Figure 15 Ceiling Configuration.....	39
Figure 16 Top View Multi-Mesh.....	45
Figure 17 Side View Multi-Mesh.....	46
Figure 18 Experimental Configuration 1.....	62
Figure 19 Experimental Configuration 2.....	63
Figure 20 Experimental Configuration 3.....	64
Figure 21 Experimental Configuration 4.....	65
Figure 22 LabVIEW Front Panel.....	69
Figure 23 LabVIEW VI.....	70
Figure 24 Radiation Balance.....	73
Figure 25 Temperature Profiles 0.76 m.....	76
Figure 26 Temperature Profiles 1.37 m.....	77
Figure 27 Temperature Profiles 1.98 m.....	77
Figure 28 Temperature Profiles 2.59 m.....	77

## List of Tables

Table 1 Test 3 Activation Times.....	15
Table 2 Test 4 Activation Time.....	16
Table 3 LHD Scaling Table.....	28
Table 4 Suggested LHD Installation Heights.....	30
Table 5 Boundary Layer Thickness Results.....	41
Table 6 Free Jet Thickness Results.....	42
Table 7 Simulations Completed.....	44
Table 8 8 ft. Ceiling hrr.csv File.....	46
Table 9 8 ft. Ceiling devc.csv File.....	47
Table 10 8 ft. Ceiling FDS Run Times.....	48
Table 11 FDS Ceiling Comparison.....	49
Table 12 Yellow Pine Properties.....	49
Table 13 Steady State Times.....	50
Table 14 Adiabatic vs. Yellow Pine.....	50
Table 15 Ceiling Height vs. FDS Accuracy.....	55
Table 16 Temperature Difference According to Distance from Fire.....	56
Table 17 Maximum Velocity at Radial Distances.....	74

## **Chapter 1: Organization**

According to the requirements set by NFPA 72, Linear Heat Detection (LHD) must be installed no more than 50.8 cm (20 in.) from a flat ceiling. While the NFPA requirements are based on the best educated hypothesis from the fire protection engineering community, they have not been verified yet. The work was conducted in hopes of providing a better understanding of the requirements set by the NFPA.

Most of the important information is located in Chapter 2, the Conference Paper. Information regarding testing details and results, analysis, validation, and final thoughts and conclusion are all included. Chapter 3 consists of suggestions regarding future work, following Chapter 3 are the appendices. There are ten total appendices, most of these appendices include details that could not be included in Chapter 2. The appendices are as follows; Ceiling Jet, FDS Report, LHD Installation Guide, Test Plan, LabVIEW, Thermocouples, Test Results, Final Presentation, FDS Input Files, and Installation Design.



## **Chapter 2: Conference Paper**

### **Introduction**

LHD is a line-type form of heat detection allowing for it to detect fire anywhere along its length. LHD is ideal for large open spaces such as warehouses, chemical storage facilities, tunnels, subways, and bridges. Inside the protective outer jacket of the LHD cable are two insulated wires, these wires are insulated in a polymer that is designed to break down at certain temperatures. When the polymer breaks down, the wires come into contact which bypasses the end-line-resistor creating an increase in current. The fire alarm panel recognizes the increase as an activation, and signals alarms and sprinklers. Due to the breakdown of the polymer, it is required that the LHD be replaced after every activation.

To make sure that the LHD activates in a timely manner, its location below the ceiling is important. Its placement should be within the ceiling jet formed during a fire growth scenario. The NFPA's depth requirement of 50.8 cm (20 in.) [1] is an attempt to guarantee that the LHD will be placed within the ceiling jet. However, the ceiling jet thickness is affected by the ceiling height which means in some cases 50.8 cm (20 in.) may not be located in the ceiling jet, causing a delayed activation. In the current work, the NFPA requirement is studied in the context of general fire behavior under flat ceilings considering both physical models and computer simulations.

### **Test Details**

One technique used to study the NFPA 72 depth requirement for LHD was to run physical experiments. In total, four different experimental configurations were used, only two of which tested

LHD activation times. The following sections will detail equipment used, experimental configurations, and the purpose of each test. Each test made use of a 7.3 m (24 ft.) x 7.3 m (24 ft.) ceiling with no walls, preventing any smoke layer from forming. In each test, the burner was placed 2.44 m (8 ft.) below the center of the ceiling. A more detailed section of the test schematics and set up can be found in the Test Plan, Appendix D.

The tests were split into two different groups. The first group was conducted to provide temperature profiles up to 25.4 cm (10 in.) below the ceiling using thermocouple trees. The second group of tests made use of LHD and recorded the activation times of the LHD. The recorded temperatures from the second group of tests were used to confirm repeatability between the two tests groups.

## **Equipment**

In each experimental configuration, thermocouple trees were used to collect temperature readings. Each test had four thermocouple trees, two on each side of the burner, shown in Figures 18-21. Two trees (one on each side) were 25.4 cm (10 in.) in length with 11 thermocouples, spaced at 2.54 cm (1 in.), starting at 0 cm and ending at 25.4 cm (10 in.) below the ceiling. The second two trees (one on each side) were 11.4 cm (4.5 in.) in length with five thermocouples, spaced at 2.54 cm (1 in.), starting at 1.27 cm (0.5 in.) and ending at 11.4 cm (4.5 in.) below the ceiling. These thermocouples were rated for a  $\pm 2.2^{\circ}\text{C}$  error [2], which was consistent with our findings when testing the thermocouple trees. The thermocouple trees were set up so that a certain degree of resolution could be achieved. A thermocouple

reading was needed every 1.27 cm (.5 in.) for a depth of 11.4 cm (4.5 in.), so that a certain resolution could be achieved for accurate representation of the boundary layer.

In the first test, the thermocouple trees were located at radial distances of 0.76 m (2.5 ft.) and 1.37 m (4.5 ft.), with a thermocouple located every 2.54 cm (1 in.) from 0 cm to 25.4 cm (10 in.) below the ceiling. Distances of 0.76 m (2.5 ft.) and 1.37 m (4.5 ft.) were chosen due to the limited temperature inputs available for the LabVIEW system. From these temperature readings, temperature profiles can then be created at both locations. In the second test, the same thermocouple trees were used but at radial distances of 1.98 m (6.5 ft.) and 2.59 m (8.5 ft.) from the fire center. Drawings of the test set ups are shown in Figures 18-21 and more information regarding the configurations can be found in Appendix D.

In the third test, thermocouple trees were placed radially at distances of 1.98 m (6.5 ft.) and 2.59 m (8.5 ft.), which allowed for comparison of the results from the second test. In the fourth test, thermocouple trees were located in the same locations as in the first test to make sure the temperature readings could be compared for repeatability. In the third and fourth experimental configurations, LHD was added. Again, there are four LHD cables, installed at the same heights as in the third test. However, in the fourth test, the LHD are located closer (radially) to the burner than the LHD in the third test. The goal of both the third and fourth test was to be able to record activation times of the LHD at varying heights from the ceiling. From these two tests we could gain a better understanding of how LHD height affects activation time.

The LHD that was used during the testing phase was rated to activate at 68°C (155°F), which is listed as the most commonly used temperature rating [3]. In tests three and four, the LHD was set at depths of 5.1 cm (2 in.), 10.2 cm (4 in.), 15.2 cm (6 in.), and 50.8 cm (20 in.) below the ceiling. To ensure positional accuracy of varying depths, LHD's threaded rods were screwed to the ceiling; the rods were about 76.2 cm (30 in.) in length. LHD rested in the valley of u-shaped brackets located on the rods.

A propane burner was used to create the flame. The burner consisted of copper pipe with an inner diameter of 2.54 cm (1 in.) and 2 mm (0.04 in.) diameter holes located 2.54 cm (1 in.) apart. A flow rate of 190 L/min was used so that a heat release rate of 262 kW would be sustained throughout the tests. In an attempt to diffuse the flame, the burner was covered with a thin layer of pea gravel. The physical tests were run for 10 minutes each to ensure that temperatures being read by the thermocouples would reach a steady state.

LabVIEW was used for data acquisition during testing and was set to record data every 0.25 seconds. During the tests, LabVIEW was able to show the temperature readings of all the thermocouples and whether or not the LHD had activated. Once the testing was finished, LabVIEW created a report in the form of an Excel file with all the necessary data such as thermocouple temperatures and activation times of the LHD cable.

## **Uncertainties**

In each test there are uncertainties that may affect the data gathered. Such uncertainties include error in thermocouples, thermocouple height placement, and an inefficient gas burner. The

thermocouples used were rated to have an error of  $\pm 2.2^{\circ}\text{C}$  [2]. The thermocouple error can be one the causes of the different temperature profiles found when recording at the same distance from the burner. However, the differences in temperature readings were no greater than  $2.0^{\circ}\text{C}$ , or less than 10%. These tests also included the changing of thermocouple distances, so the placement of each thermocouple may be slightly changed from test to test. Once the thermocouple tree had been reinstalled at its new location the heights of each thermocouple needed to be readjusted. It is possible that these heights were not consistent and led to the calculation of different ceiling jet thicknesses. In each physical test the diffusion burner was used. It is possible that the diffusion burner was not as efficient at diffusing the flame as planned. Additionally, possible wind currents could have been present in the testing facility. These could all lead to differences between hand calculations and FDS simulations.

## **Test results**

After completing both Tests 1 and 2, the data was collected and graphed. Figure 1 below, represents each temperature profile found at the four radial distances from the fire center line. The temperature profiles were created using the recorded temperatures after a steady state was achieved. At each distance the boundary layer thickness can be defined as the distance from the top of each line to the highest recorded temperature. The boundary layer thicknesses resulting from these tests were able to give more information as to where to place the LHD cable for tests 3 and 4.

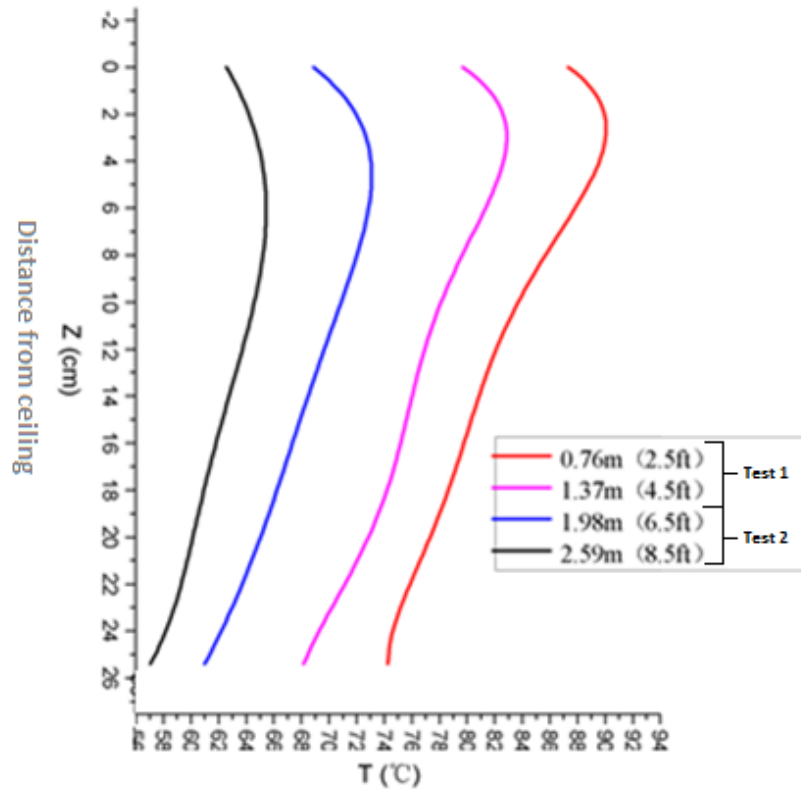

Figure 3 Test 1 & 2 Temperature Profiles

After analyzing the data from tests 1 and 2, the LHD locations below the ceiling were determined and Test 3 was conducted. The table below depicts the response times of the LHD cables.

LHD configuration	Position of LHD (distance to the ceiling)	Response time (s)	Average Steady State Temperature at 1.98m (6.5 feet) (°C)
3.66m*3.66m (12ft*12ft) box	5.08 cm (2 inches)	Not activated	75
	10.16cm (4 inches)	Not activated	71
	15.24cm (6 inches)	Not activated	68
	50.8 cm (20 inches)	Not activated	/

Table 4 Test 3 Activation Times

As seen from the table none of the LHD cables were activated when placed at 1.83 m (6 ft.) from the fire center. Although temperatures for LHD depths of 5.08 cm (2 in.), 10.16 cm (4 in.), and 15.24 cm (6 in.) did exceed the 68°C temperature rating for the LHD, the test duration was not long enough to heat the LHDs to activation.

After no activations were seen in Test 3, the LHD was moved so that it was 0.91 m (3 ft.) from the fire center. The table below shows the data recorded from Test 4.

LHD configuration	Position of LHD (distance to the ceiling)	Response time (s)	Average Steady State Temperature at 0.76m (2.5 feet) (°C)
1.83m*1.83m(6ft*6ft) box	5.08 cm (2 inches)	104s	90
	10.16cm (4 inches)	139s	85
	15.24cm (6 inches)	361s	82
	50.8 cm (20 inches)	Not activated	/

Table 5 Test 4 Activation Time

In Test 4, three of the four LHD cables activated. The only LHD cable that did not activate was located at 50.8 cm (20 in.) from the ceiling. It should be noted that 50.8 cm (20 in) is the maximum length at which LHD can be installed below the ceiling. It was expected after seeing the results from the first two tests that the three LHD cables closest to the ceiling would activate.

### Repeatability

In Tests 1 and 4, thermocouple trees were placed at the same distances from the fire center. The thermocouple setup was to make sure that the results from the first test were repeatable. Similarly, in Tests 2 and 3, thermocouple trees were placed at the same locations. While LHD was installed in the third and fourth test, the diameter of the LHD is thin enough to be ignored in terms of influencing temperature readings.

The repeatability of the test results can be seen in the charts in Appendix E. For all four charts, there's a difference between the two lines, but the boundary layer and ceiling jet are the same. The



difference between the two temperature profile lines can be explained with the 2.2°C [2] error in thermocouple measurements since the difference in temperature readings for each distance is less than 10%.

## Analysis

The figure below from Motevalli [4] shows the temperature profiles in the ceiling jet. The boundary layer is the thin region marked as  $\delta_{T_{max}}$ . It begins at the ceiling and ends at the maximum temperature. In the boundary layer, there is a very sharp temperature change. At the ceiling, the gas temperature is the same as the ceiling temperature due to the no-slip boundary condition; however, the temperature rises fast because of the convection of the hot gas driven by buoyant forces.

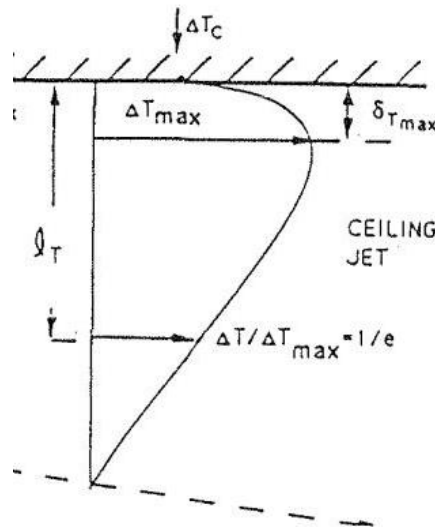

Figure 4 Ceiling Jet Profile

The thermal thickness ( $\ell_T$ ) is a characteristic length for the ceiling jet. It begins at the ceiling and ends where the following equality is true:  $\frac{\Delta T}{\Delta T_{max}} = \frac{1}{e}$ . In the ceiling jet, the temperature is considered to be

high due to the smoke and hot combustion gases from the fire while the temperature outside the ceiling jet is considered to be much closer to room temperature. More importantly the difference in temperature between the boundary layer and ceiling jet is not significant, which is important for LHD activate.

According to the known properties of the ceiling jet temperature profile, a reasonable LHD installation position should be between the boundary layer and the ceiling jet where the temperature is relatively high and the distribution is even. While the boundary layer is not affected by total ceiling height, the thermal thickness is affected [7]. The ceiling height effect is important to note because the NFPA 72 requirement is a standard for all ceiling heights [1]. However, the ceiling jet may not be 50.8 cm (20 in.) thick. For example, from the findings of the tests with a 2.44 m (8 ft.) ceiling, the thermal thickness is less than 50.8 cm (20 in.) with the given fire.

### **FDS Simulation Results**

FDS simulations were completed for ceiling heights ranging from 2.44 m (8 ft.) to 12.19 m (40 ft.). In the simulations no walls were present to replicate our physical configurations, and the ceiling size was large enough so that it could be interpreted as an infinite ceiling. More information on the simulation's configurations can be found in Appendix B.

Once both testing and simulations were complete, the results were compared using the graphs below. There is a large difference in temperature between the tests and simulations. The inconsistency can also be found in the work of Hurley and Munguia, which is detailed further in Appendix B [5]. The difference in temperature may be credited to the diffusion burner not diffusing the flame as efficiently as

was expected. Air entrainment initiated by the gas jets from the small holes on the ring burner will influence the heat transfer and change the temperature profile. In Figures 3-6, the blue vertical line represents the physical results while the red line represents the FDS simulation. The orange horizontal lines show the boundary layer thickness and the horizontal black lines show the ceiling jet thickness.

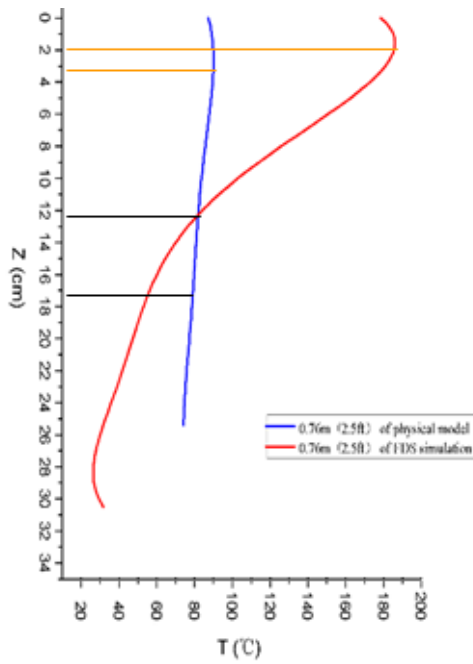

Figure 3 0.76m (2.5 ft.)  
FDS & Test Temperature Profile

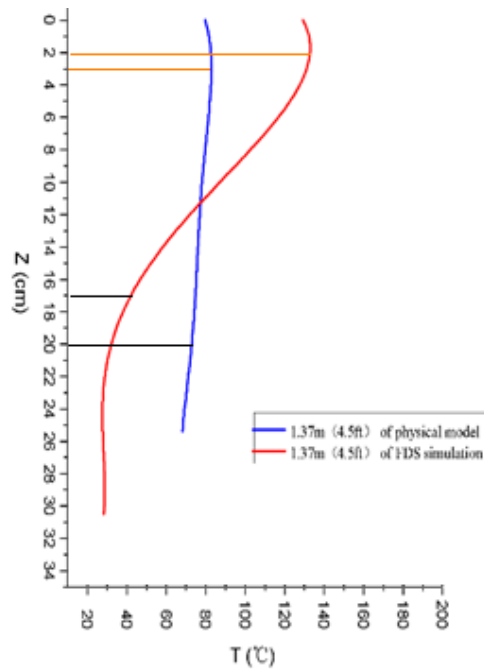

Figure 4 1.37m (4.5 ft.)  
FDS & Test Temperature Profile

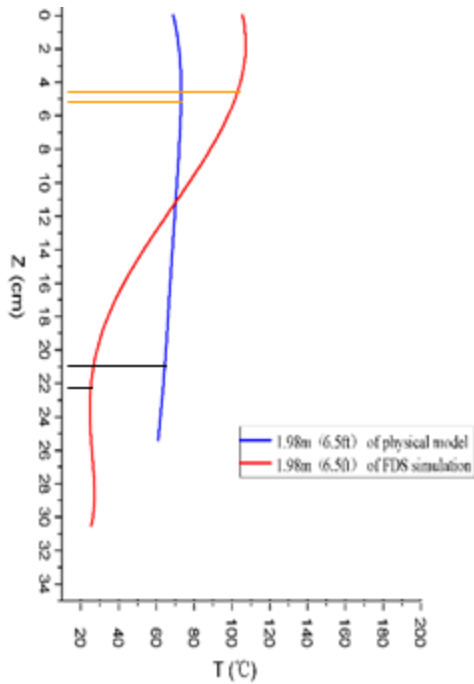

Figure 5 1.98m (6.5 ft.)  
FDS & Test Temperature Profile

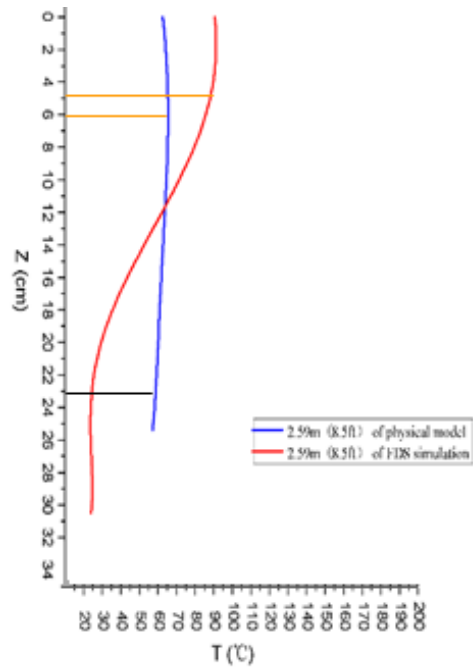

Figure 6 2.59m (8.5 ft.)  
FDS & Test Temperature Profile

For the boundary layer thickness, FDS could not predict an accurate value because the cell size of 5 cm (2 in.) used in the simulation is larger than the boundary layer thickness. However, the thermal thickness shows the same trend as the temperature. The difference in thermal thickness decreases with increasing radial distance, which can be noted by comparing Figure 3 and Figure 6.

### Comparison to Previous Work

To make sure that the findings from the physical tests and FDS simulations are consistent with other findings among the fire protection community, hand calculations of the boundary layer thickness,

thermal thickness, and maximum temperature were undertaken. These results were then compared to the physical test and simulation results.

### Boundary Layer Thickness

To calculate the boundary layer thickness, the following equation from Motevalli and Marks was used [4].

$$\delta_{Tmax} = 0.0152(r)^{1.35} \text{ for } 0.26 \leq \frac{r}{H} \leq 2.0 \quad \text{Eq. 1}$$

The boundary layer thicknesses were calculated using equation 1 for radial distances of 0.76 m (2.5 ft.), 1.37 m (4.5 ft.), 1.98 m (6.5 ft.), and 2.59 m (8.5 ft.) from the fire’s vertical centerline. The calculated results were then compared to the findings of the test and simulation results, as shown in Figure 7.

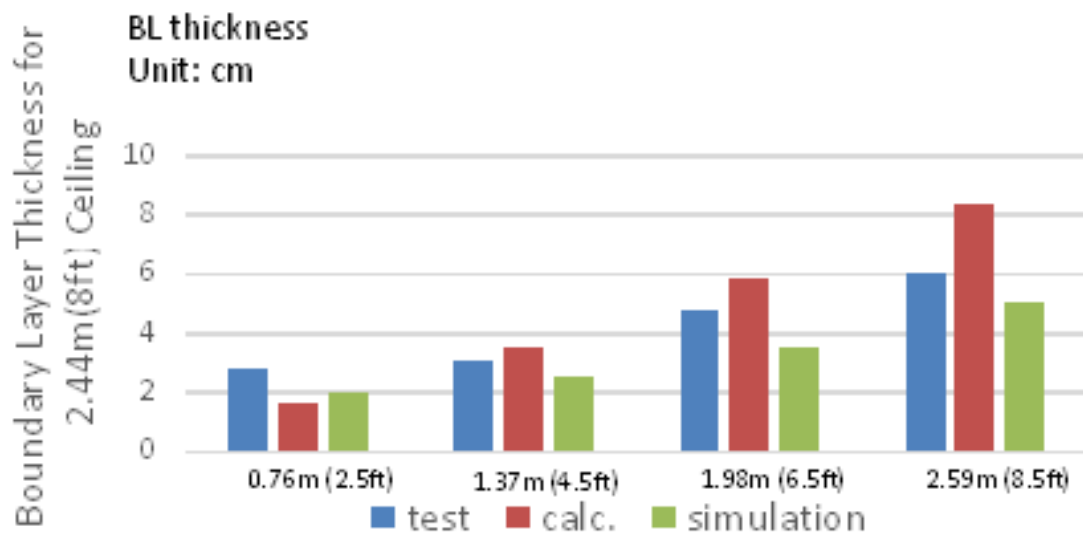

Figure 7 Boundary Layer Comparisons for 2.44 m (8 ft.) Ceiling Height

For distances of 1.37 m (4.5 ft.) and greater, the calculated thickness is greater than the findings from both the physical test and simulations. The average difference between the hand calculations and the tests was about 20%. The average difference between the hand calculations and the simulation was about 35%. This may be contributed to the diffusion burner not being as efficient during the tests or possibly air currents in the testing area (although care was taken to reduce the currents as much as a physically possible). The reason for the calculations being greater than the FDS simulations is likely because in FDS the boundary layer is sub-grid scale. With the boundary layer smaller than our fine mesh cells FDS cannot accurately portray the temperature readings within the boundary layer.

### **Thermal Thickness**

The thermal thickness was calculated for the same radial distances as the boundary layer thickness calculations. They were also calculated only for the 2.44 m (8 ft.) ceiling as that was the only ceiling height that was physically tested. To calculate the thermal thickness, the equation below from Motevalli and Marks was used [4].

$$\frac{\ell_T}{H} = 0.112 \left( 1 - \exp \left[ -2.24 \left( \frac{r}{H} \right) \right] \right) \text{ for } 0.26 \leq \frac{r}{H} \leq 2.0 \quad \text{Eq. 2}$$

From Motevalli and Marks' thermal thickness equation, the following results were found.



Figure 8 Thermal Thickness Comparison

Unlike the findings from the boundary layer thickness calculations the thermal thickness calculation is more consistent with the test and FDS results. From 1.37 m (4.5 ft.) to 2.59 m (8.5 ft.) from the fire center, the thermal thicknesses are all within 10% of each other. The consistent results help verify that FDS can simulate an accurate thermal thickness, and validate the findings from FDS with ceiling heights that were not physically tested.

### Highest Temperature Calculation

After completing both the boundary layer and thermal thickness calculations, the highest temperature was calculated as a final means of comparison. Using the following calculation from Alpert for steady state fires [6], the highest temperature was calculated for the 2.44 m (8 ft.) ceiling at distances of 0.76 m (2.5 ft.), 1.37 m (4.5 ft.), 1.98 m (6.5 ft.), and 2.59 m (8.5 ft.) from the fire center.

$$T - T_{\infty} = \frac{5.38 \left(\frac{Q}{r}\right)^{\frac{2}{3}}}{H} \text{ for } \frac{r}{H} \geq 0.18 \quad \text{Eq. 3}$$

From Alpert's equation the following data were created comparing the results from calculations, test results, and simulation results.

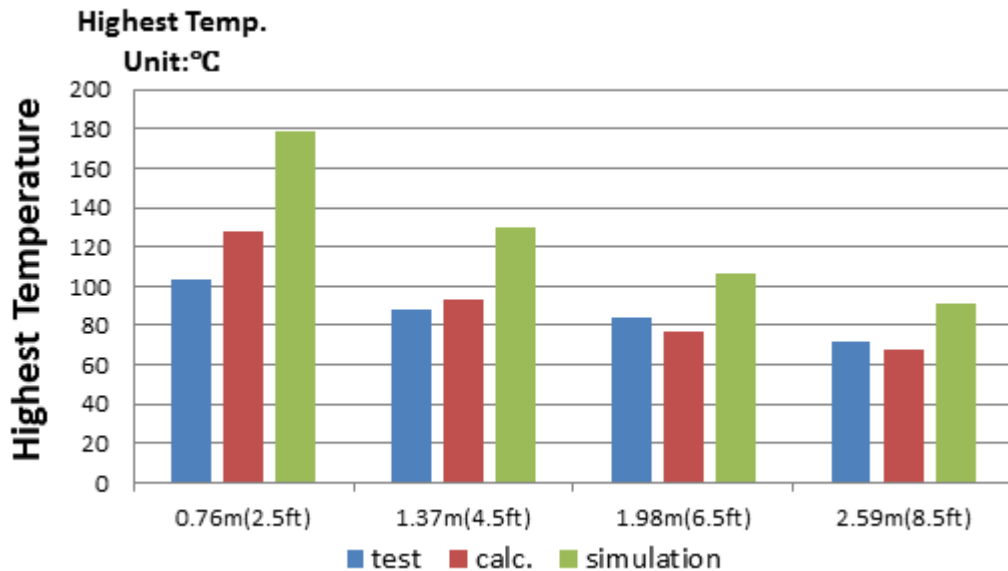

Figure 9 Highest Temperature Comparison

At each distance from the fire center line, the simulated highest temperature is greater than both the highest recorded and highest calculated temperature. On average, the difference between the test temperatures and the simulated temperatures is about 30% and the difference between the calculated and simulated temperatures is about 27%. The results are consistent with the findings of Hurley and Munguia, who report that FDS simulated temperatures are greater than actual temperatures [5]. Hurley and Munguia also report that as ceiling height increases so does the accuracy of simulated temperatures in FDS [5], which is especially important because FDS was used to simulate higher ceiling heights that could not be physically tested in the current study. More information can be found in Appendix B.



Despite the simulated temperature being greater than expected, the actual and calculated greatest temperatures only differ by about 9%.

## Literature Profiles

In addition to completing calculations to compare the findings from FDS and physical testing, research of available literature was also conducted. To compare the findings from the current work's testing series, Motevalli's work on transient ceiling jet temperature profiles was researched [4]. Below is a comparison of Motevalli's findings compared to the results from the 2.44 m (8 ft.) test.

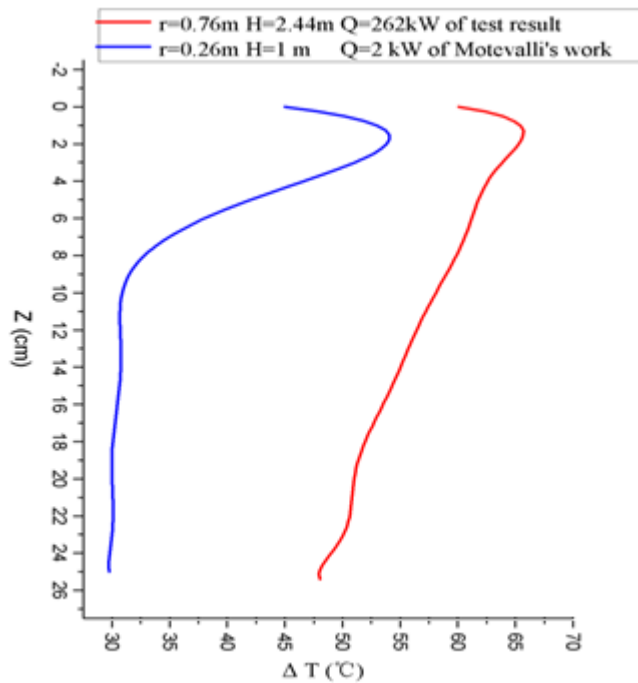

Figure 10 Comparison of Motevalli & Test Temperature Profile

In Motevalli's test, a ceiling height of 1 m (3.28 ft.) and a HRR of 2 kW were used. Although there is a large difference in the  $\Delta T$  values the boundary layer thickness from Motevalli's findings is

similar to the thickness found in the testing from the 2.44 m (8 ft.) ceiling. The reason for the similarity is because the difference in radial distance from the fire center to the temperature readings is not very large. The difference in  $r/H$  values is only .05. Motevalli's results help provide validity for the boundary layer thickness findings for the 2.44 m (8 ft.) test ceiling.

## **Conclusion**

### **Test Results**

The test results for boundary layer thickness and thermal thickness are close to the results from the literature. The test results for the highest temperatures in the ceiling jet are smaller than the values calculated by Motevalli's empirical equations [4], but it can be potentially explained by the different burners. In Motevalli's tests, a methane burner with 2.7 cm (1.06 in.) diameter was used [4]. However, the burner in this experiment was a 0.61 m x 0.61 m (2 ft. x 2 ft.) propane ring burner with pea gravel to diffuse the flame.

### **FDS Simulation Results**

The FDS simulation results for the boundary layer thickness do not provide accurate results because the minimum cell size in the simulations was 5.08cm (2in), which is larger than the boundary layer thickness. The simulated results differed from the test results by about 18% However, the simulation results for thermal thickness differ by less than 10% when compared to the test results and calculations. The simulation results for the highest temperatures in the ceiling jet are greater than the values from the tests and literature which has been observed by Hurley and Munguia. [5].

## Scaling

In test 4, a 1.83 m x 1.83 m (6 ft. x 6 ft.) LHD box was used which gave a radial distance of 0.91 m (3 ft.) from the fire center. From the following table, if a 2.44 m (8 ft.) ceiling was scaled to 12.19 m (40 ft.) and the same  $r/H$  was kept, a radial distance from the fire center of 4.57m (15ft) would be the equivalent LHD spacing.

Ceiling Height	$r/H$	LHD spacing
2.44m (8ft)	0.375	0.91m (3ft)
12.19m (40ft)	0.375	4.57m (15ft)

Table 6 LHD Scaling Table

However, the maximum installation spacing for LHD in a room with ceiling heights greater than 9.75m (32ft) is 3.05m (10ft) [3]. If  $r/H$  was to scale linearly, than theoretically at 12.19 m (40 ft.) the LHD can be expected to also activate being that the LHD distance is greater than the maximum, 3.05 m (10 ft.).

## Thermal Thickness

Based on the temperature profiles from the tests and Motevalli's paper [4], it is reasonable to install LHD or other detectors between the boundary layer and ceiling jet. According to the simulations and calculations (Eq. 2), the thermal thicknesses are graphed versus the ceiling height.

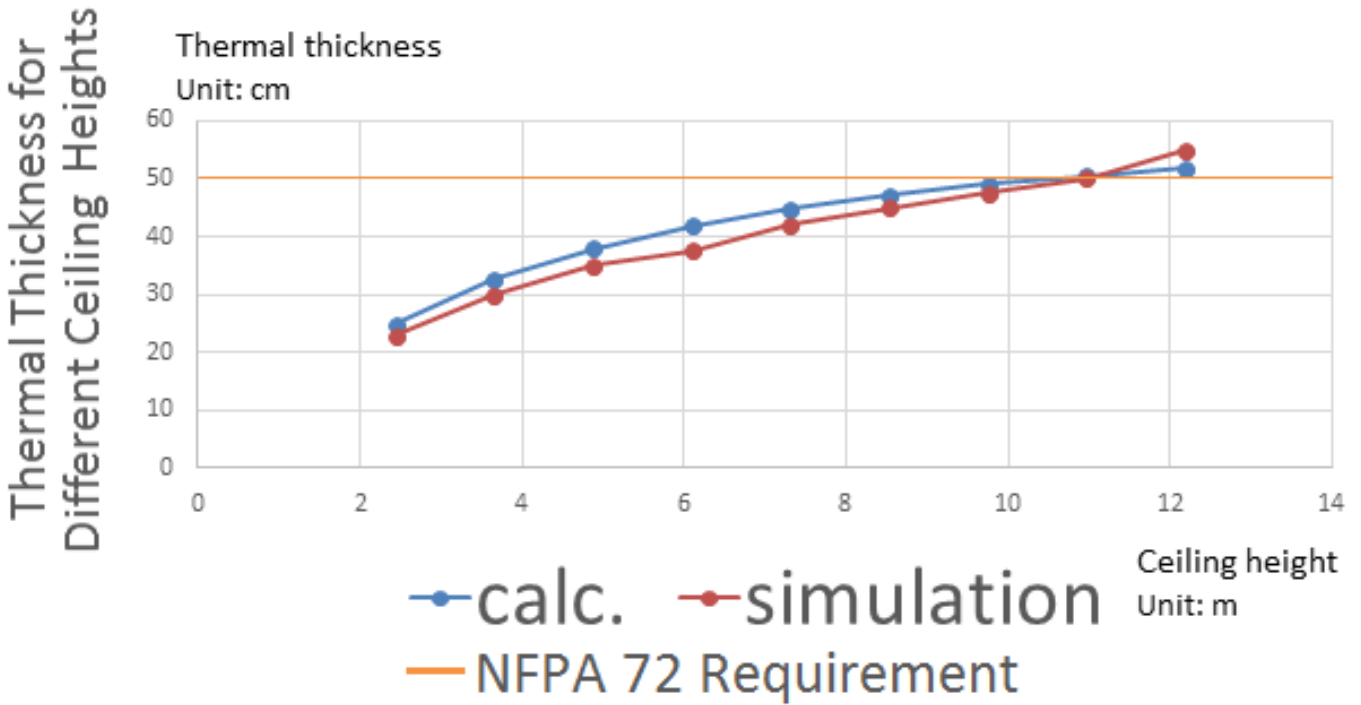

Figure 11 Thermal Thicknesses for Different Ceiling Heights

From Figure 11, the 0.508 m (20 in.) requirement is not valid for all ceiling heights. For ceiling heights less than 11 m (36 ft.), 0.508 m (20 in.) is larger than the ceiling jet. Installing LHD at 0.508 m (20 in.) below the ceiling will cause for a slow activation or no activation at all, as was seen in test 3. For ceiling heights greater than 11 m (36 ft.), the thermal thickness is greater than 0.508 m (20 in.). For ceiling heights 11 m (36 ft.) or greater the NFPA 72 requirement is valid for a maximum distance from the ceiling.

**Installation Suggestions:**

After analyzing the results of thermal thicknesses future installation heights for LHD have been suggested. Below is a table that describes suggested installation heights based of different total ceiling heights, see Table 4.

Total Ceiling Height (m)	Total Ceiling Height (ft.)	LHD Installation Height (m)	LHD Installation Height (in.)
2.44	8	0.10-0.25	3.96-9.84
3.66	12	0.15-0.31	5.88-12.24
4.88	16	0.20-0.36	7.92-14.16
6.10	20	0.25-0.40	9.84-15.72
7.32	24	0.25-0.42	9.84-16.56
8.53	28	0.25-0.46	9.84-18.12
9.75	32	0.25-0.49	9.84-19.32
10.97	36	0.30-0.50	11.76-19.68
12.20	40	0.30-0.52	11.76-20.52

Table 4 Suggested LHD Installation Heights

These ceiling heights are an attempt to guarantee the LHD is placed within the ceiling jet to ensure a timely activation. If the LHD is placed outside the thermal thickness, it is possible for the LHD to have a delayed activation or no activation at all. Also, if the LHD is placed within the boundary layer, it is possible for the LHD to be located within the no-slip condition causing for delayed activation or no activation at all.

## Works Referenced

- [1] National Fire Protection Association. "NFPA 72: National Fire Alarm and Signaling Code." 2013 Edition. National Fire Protection Association, Print. 3 June 2013.
- [2] "Thermocouple Wire Special Limits of Error." *Thermocouple Wire Special Limits of Error*. Omega Engineering Inc., n.d. Web. 06 Aug. 2013. <[http://www.omega.com/pptst/SLE\\_Wire.html](http://www.omega.com/pptst/SLE_Wire.html)>.
- [3] *Tyco Fire and Building Products*. N.p.: Tyco Fire Products LP, 2007. Print.
- [4] V. Motevalli and C. Marks, "Characterizing the Unconfined Ceiling Jet Steady-State Conditions: A Reassessment", in *Fire Safety Science Proceedings of the 3rd International Symposium*, Elsevier Pub Co, Inc, 1991, pp. 301–312.
- [5] M. Hurley and A. Munguia. *Analysis of FDS Thermal Detector Response Prediction Capability*. NIST GCR 09-921, National Institute of Standards and Technology, Gaithersburg, Maryland, 2009.
- [6] R.L. Alpert. "Turbulent Ceiling-jet Induced by Large-scale Fires," *Combustion Science and Technology*, 11, pp. 197-213, (1975).
- [7] DiNenno, P.J., et al., Editors, *SFPE Handbook of Fire Protection Engineering*, 2<sup>nd</sup> Edition, Chapter 4, Section 2, 2/32-2/39 pp.

- [8] Hu, R.L., et al., "Critical wind velocity for arresting upwind gas and smoke dispersion induced by near-wall fire in a road tunnel." *Journal of Hazardous Material*. Jan. 2008. Web.
- [9] R.L. Alpert. "The Fire Induced Ceiling Jet Revisited." PowerPoint.  
<<http://www.see.ed.ac.uk/FIRESEAT/files11/FS11-Presentation1-Alpert.pdf>>.
- [10] *LabVIEW System Design Software*. Computer software. *NI LabVIEW*. N.p., n.d. Web. 05 Aug. 2013.  
<<http://www.ni.com/labview/>>.
- [11]"MPICH2." *MPICH2*. SERC, n.d. Web. 16 Aug. 2013.
- [12]"Installation of MPICH2 on Windows XP/Vista/7." *Installation of MPICH2 on Windows XP/Vista/7*. The SWASH Team, 2 Apr. 2013. Web. 16 Aug. 2013.
- [13] K.B. McGrattan, S. Hostikka, J.E. Floyd, and R. McDermott. *Fire Dynamics Simulator (Version 5), Technical Reference Guide*. NIST Special Publication 1018-5, National Institute of Standards and Technology, Gaithersburg, Maryland, October 2010. 7.
- [14] E.R.G Eckert and R.M. Drake, *Analysis of Heat and Mass Transfer*, McGraw-Hill, New York (1972).

## **Appendix A: Ceiling Jet**

### **Background:**

In most commercial, storage, and modern residential buildings, fire detection and suppression systems are becoming a common sight. In just about all of these buildings the fire suppression and detection systems are located feet or sometimes just inches below the ceiling. The placement of these systems is crucial for their response times. Rather placing them lower, closer to the possible heat source, it is more beneficial to have them located in the ceiling jet. The ceiling jet will determine when and how long it takes for these devices to activate [6]. Ceiling jets are known as rapid gas flows in a relatively thin layer beneath the surface of the ceiling. It is driven by the buoyancy of the hot gas transferred by the fire plume [7].



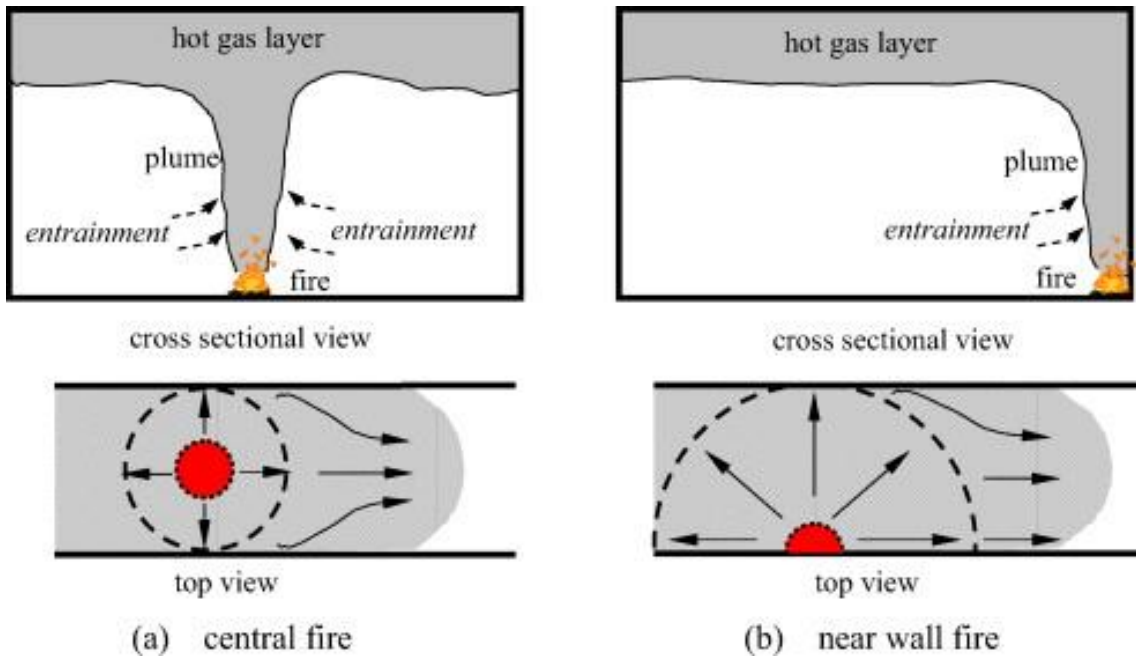

Figure 12. Fire Diagram [8]

Ceiling jets are created when hot gases trapped in the fire plume come in contact with the ceiling causing them to spread out across the ceiling as shown in Figure 1. The ceiling jet will contain the greatest temperatures in the room aside from the fire and fire plume. Fire suppression and detection systems are placed near the ceiling due to the increased temperature inside the ceiling jet allowing for the fastest response times.

**Boundary Layer and Free Jet:**

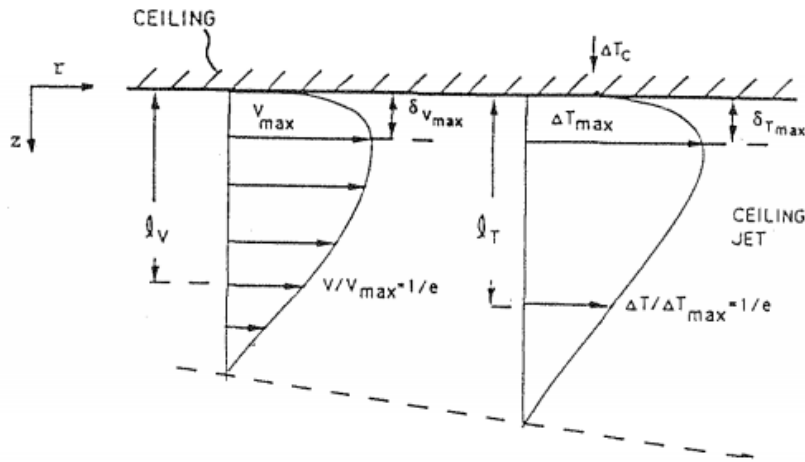

Figure 13 Ceiling Jet Diagram [4].

The behavior of the ceiling jet as a function of position under steady-state conditions can be identified by Figure 2 above. The ceiling jet momentum and thermal boundary layer thickness,  $\delta_{v_{max}}$  and  $\delta_{T_{max}}$  respectively, identify a region of the jet where flow velocity and temperature vary from the wall no-slip conditions to maximum values  $V_{max}$  and  $\Delta T_{max}$  [6]. At distances beyond  $\delta_{max}$ , the ceiling jet flow behaves like a free jet and its growth may be defined by thermal and momentum Gaussian thickness,  $\ell_T$  and  $\ell_V$ , respectively [6].

Ceiling Jet Boundary Layer Characteristic Thickness,  $\delta_{v_{max}}$  and  $\delta_{T_{max}}$

$$\delta_{V_{max}} = 0.0187 (r)^{0.668} \quad 0.26 \leq r/H \leq 2.0$$

$$\delta_{T_{max}} = 0.0152 (r)^{1.35} \quad 0.26 \leq r/H \leq 2.0$$

Ceiling Jet Gaussian Momentum and Thermal Thickness,  $\ell_T$  and  $\ell_V$

$$\ell_V/H = 0.205 (1 - \exp[-1.75(r/H)]) \quad 0.26 \leq r/H \leq 1.5$$

$$\ell_T/H = 0.112 (1 - \exp[-2.24(r/H)]) \quad 0.26 \leq r/H \leq 2.0$$

## Solving for Ceiling Jet Thickness:

To solve for our potential ceiling jet thickness we were first required to calculate other values, such as the heat release rate (HRR) for our steady state fires and the boundary layer thickness. Our FDS simulations were able to give us a good temperature profile for the free jet, however, our boundary layer was sub-grid scale requiring hand calculations.

### 1. HRR for steady fires

For heat release rate, we use the correlations developed by Alpert for determining maximum ceiling jet temperatures in SI units.

$$T - T_{\infty} = \frac{16.9\dot{Q}^{2/3}}{H^{5/3}} \text{ for } r/H \leq 0.18,$$

$$T - T_{\infty} = \frac{5.38(\dot{Q}/r)^{2/3}}{H} \text{ for } r/H \geq 0.18, \text{ where temperature, } T, \text{ is in } ^{\circ}\text{C}; \text{ and total energy release}$$

rate,  $\dot{Q}$ , is in kW; and the ceiling height and radial position (r and H) are in meters [7].

$\dot{Q}_0^*$ , is the generalized variable for energy release rate which is developed from Heskestad and Delichatsios's correlations.

$\dot{Q}_0^* = \dot{Q} / (\rho_{\infty} C_p T_{\infty} g^{1/2} H^{5/2})$ , where total energy release rate,  $\dot{Q}$ , is in kW; the air density at room temperature,  $\rho_{\infty}$ , is in  $\text{kg/m}^3$ ; the heat capacity of air at room temperature,  $C_p$ , is in  $\text{kJ/kg}\cdot\text{K}$ ; the room temperature,  $T_{\infty}$ , is in K; the acceleration of gravity, g, is in  $\text{m/s}^2$ ; and the ceiling height, H, is in meters

Below is a calculation of HRR for different ceiling height to reach a steady temperature of 68°C at 2.59m ( $6\sqrt{2}$  ft) from the fire center.

ceiling H(m)	ceiling H(ft)	HRR Q'(kW) $r/H \geq 0.18$	Q*(sprinkler)
2.4384	8	262.4382167	0.026062012
3.048	10	366.7685577	0.02084961
3.6576	12	482.1297899	0.017374675
4.2672	14	607.5529738	0.014892578

4.8768	16	742.2873706	0.013031006
5.4864	18	885.7289812	0.011583116
6.096	20	1037.378137	0.010424805
6.7056	22	1196.812506	0.009477095
7.3152	24	1363.668975	0.008687337
7.9248	26	1537.630976	0.008019081
8.5344	28	1718.419311	0.007446289
9.144	30	1905.78533	0.00694987
9.7536	32	1749.588111	0.005429586
10.3632	34	1916.14878	0.005110198
10.9728	36	2087.68323	0.004826299
11.5824	38	2264.051213	0.004572283
12.192	40	2445.123718	0.004343669

Table 7 Q' & Q\* Results

Below is the graph of heat release rate with ceiling height.

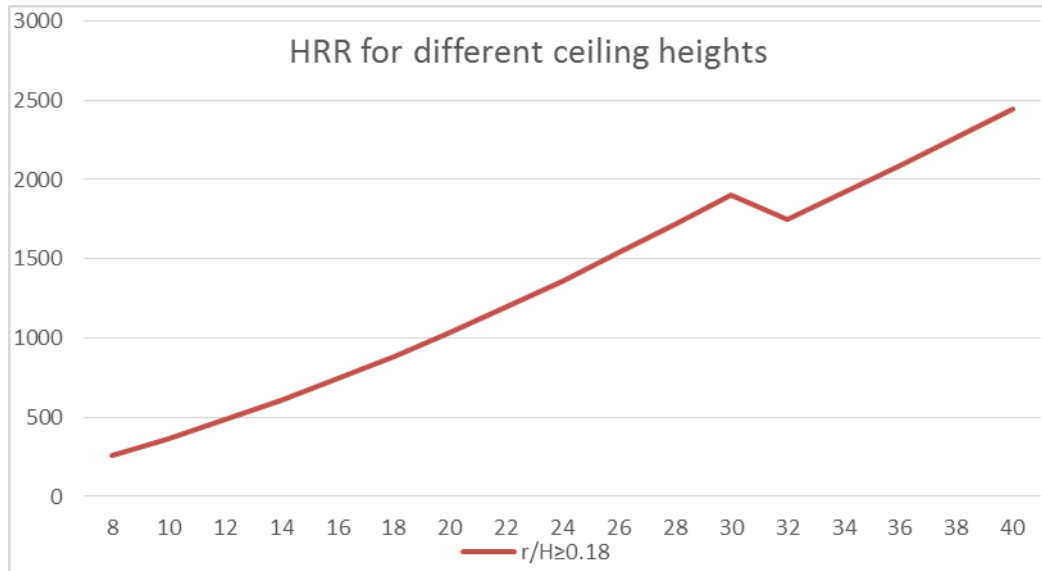

Figure 14 HRR for Ceiling Heights

Below is the picture of ceiling configuration.

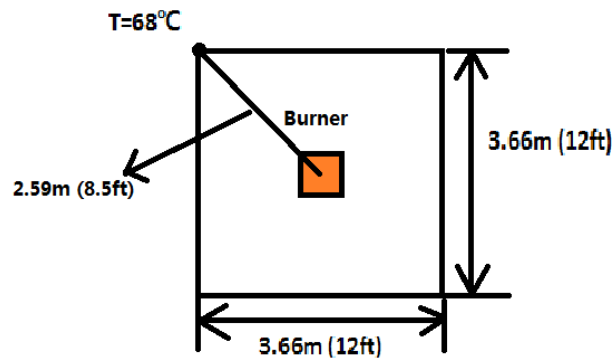

Figure 15 Ceiling Configuration

More details can be found in the appendix file, QandQstar.xlsx.

## 2. Boundary layer thickness

The velocity and temperature profiles and ceiling jet growth quantify the momentum and energy contents and their transport within the ceiling jet. Wall jet studies of Glauert and Poreh, et.al.

[9] have established the ceiling jet to be a boundary-layer type flow. The key parameters which define the behavior of the ceiling jet as a function of position under steady-state conditions can be identified according to Figure 2. The ceiling jet momentum and thermal boundary layer thicknesses are denoted as  $\delta_{V_{max}}$  and  $\delta_{T_{max}}$  respectively. They identify a region of the jet where flow velocity and temperature vary from the wall no-slip conditions to maximum values  $V_{max}$  and  $\Delta T_{max}$ . At distances beyond  $\delta$ , the ceiling jet flow behaves like a free jet and its growth may be defined by thermal and momentum Gaussian thickness,  $\ell_T$  and  $\ell_V$ , respectively [9].

The ceiling jet growth and thickness is characterized by the two parameters  $\delta$  and  $\ell$  as defined in Figure 2. Alpert developed an integral model for the ceiling jet where  $\delta_{V_{max}}$  was shown to be a function of  $r$  alone when  $Q$  is in the order of tens of kilowatts. He also assumed that the momentum length scales and thermal length scales to be the same; i.e.  $\delta_{V_{max}} = \delta_{T_{max}}$  and  $\ell_T = \ell_V$ . The dependency of  $\delta$  on  $r$  alone was confirmed by plots of  $\delta_{T_{max}}$  vs.  $r$  and the empirical equations constructed [9],

$$\delta_{V_{max}} = 0.0187(r)^{0.668} \text{ for } 0.26 \leq \frac{r}{H} \leq 2.0$$

$$\delta_{T_{max}} = 0.0152(r)^{1.35} \text{ for } 0.26 \leq \frac{r}{H} \leq 2.0$$

Below is the boundary layer thickness for the 8 ft. (2.44m) ceiling.

r(distance to fire center)(m)	H(m)	r/H	BL thickness(m)	BL thickness(cm)
0.762	2.44	0.3125	0.0160	1.595
1.37	2.44	0.5625	0.0353	3.529
1.98	2.44	0.8125	0.0580	5.798
2.59	2.44	1.0625	0.0833	8.329

Table 8 Boundary Layer Thickness Results

### 3. Free jet thickness

A mathematical approximation of the form  $Ax^D e^{-Cx}$  was fitted to every steady-state velocity and temperature profile (a total of 30 profiles) and the respective values of  $\ell_T$  and  $\ell_V$  were obtained from these fits. Plot of  $\ell_V/H$  vs.  $r/H$  correlated quite well for  $r/H \leq 0.75$  whereas the correlation suffered significantly beyond this  $r/H$  value. The growth of  $\ell_T$  and  $\ell_V$  are delayed as  $r/H$  increases and they approach a constant thickness. The asymptotic behavior of  $\ell_T$  and  $\ell_V$  is thought to be due to the effect of  $Ri > 1$ . The free jet flow, and thus  $\ell_T$  and  $\ell_V$  are effected much more by the buoyancy than the near ceiling flow region. It can also be stated that  $\ell$  is scaled by  $H$  since it characterizes the free jet portion of the ceiling jet and it is analogous to the Gaussian thickness of the plume as long as  $\ell \ll H$ . This explains why  $\ell_V$  data has more scatter beyond  $r/H=0.75$  where  $\ell_V$  is about 15% of  $H$ . The empirical relations defining  $\ell_T$  and  $\ell_V$  are shown below [9]:



$$\ell_v/H = 0.205 \left( 1 - \exp \left[ -1.75 \left( \frac{r}{H} \right) \right] \right) \quad 0.26 \leq r/H \leq 1.5$$

$$\ell_\tau/H = 0.112 \left( 1 - \exp \left[ -2.24 \left( \frac{r}{H} \right) \right] \right) \quad 0.26 \leq r/H \leq 2.0$$

Below is the free jet thickness for the 8 ft. ceiling :

r(distance to fire center)(m)	H(m)	r/H	thermal thickness(m)	thermal thickness(cm)
0.762	2.44	0.3125	0.137	13.7
1.37	2.44	0.5625	0.196	19.6
1.98	2.44	0.8125	0.229	22.9
2.59	2.44	1.0625	0.248	24.8

Table 9 Free Jet Thickness Results

### Scaling:

An important trait of ceiling jets is that, as long as the flow is turbulent, the temperature and velocity can be predicted. According to equations found by Alpert and also Heskestad and Delichatsios [9], the temperature and velocity within the ceiling jet can be scaled based on the magnitude of the other quantities.

Alpert's equations are as follows [6]:

$$T - T_\infty = \frac{16.9Q_r^{2/3}}{H^{5/3}} \quad \text{for } r/H \leq 0.18$$

$$T - T_{\infty} = \frac{5.38(Q'/r)^{2/3}}{H} \quad \text{for } r/H > 0.18$$

$$U = 0.96\left(\frac{Q'}{H}\right)^{1/3} \quad \text{for } r/H \leq 0.15$$

$$U = \frac{0.196Q'^{1/3}H^{1/2}}{r^{5/6}} \quad \text{for } r/H > 0.15$$

Where  $T$  ( $^{\circ}\text{C}$ ) is the final temperature,  $T_{\infty}$  ( $^{\circ}\text{C}$ ) is ambient temperature,  $Q'$  (Q dot) (kW) is the total energy release rate,  $H$  (m) is the ceiling height, and  $r$  (m) is the radial position [6].

Heskestad and Delichatsios' equations are as follows [6]:

$$\dot{Q}_0^* = \dot{Q} / (\rho_{\infty} C_p T_{\infty} g^{1/2} H^{5/2})$$

$$\Delta T'_{\circ} = \Delta T / T_{\infty} / (\dot{Q}_0^*)^{2/3} = [0.188 + 0.313r/H]^{-4/3}$$

$$U'_{\circ} = 0.68(\Delta T'_{\circ})^{1/2} (r/H)^{-0.63} \quad \text{for } r/H \geq 0.3$$

Where  $\rho_{\infty}$  ( $\text{kg}/\text{m}^3$ ) is density,  $C_p$  ( $\text{kg}^*\text{K}$ ) is specific heat and  $g$  ( $\text{m}/\text{s}^2$ ) is gravity. The other variables in the Heskestad and Delichatsios' equations are the same as the variables in Alpert's equations.

When scaling both Alpert's and Heskestad and Delichatsios' equations are appropriate. On average however, the Heskestad and Delichatsios's equations will predict a larger rise in temperature and velocity when compared to Alpert's equations<sup>3</sup>. When predicting our fire sizes we used Alpert's

equations. It should be noted that these equations are only appropriate for steady state fires where the hot gases are obstructed only by a ceiling, no walls.

### Appendix B: FDS Report

To determine which cell size was appropriate three tests were run for an 8 ft. ceiling, each with a different cell size. After completing the three tests the results were analyzed to decide which fine mesh size would allow for the most accurate results which required the least amount of run time.

The simulations finished are as follows

	Height(m)	Coarse mesh	Fine mesh	HRRPUA(kW/m <sup>2</sup> )	Burner size	Ceiling
8'1.5'	2.4384	0.5'(0.1524 m)	1.5''(0.381m)	725	2'x2'(0.60 96m)	adiabatic
8'2''	2.4384	1'(0.3048m)	2''(0.050 8m)	725	2'x2'(0.60 96m)	adiabatic

8'3''	2.4384	1'(0.3048m )	3''(0.076 2m)	725	2'x2'(0.60 96m)	adiabatic
-------	--------	-----------------	------------------	-----	--------------------	-----------

Table 10 Simulations Completed

To save time, multiple meshes were used. Below is the configuration of the meshes.

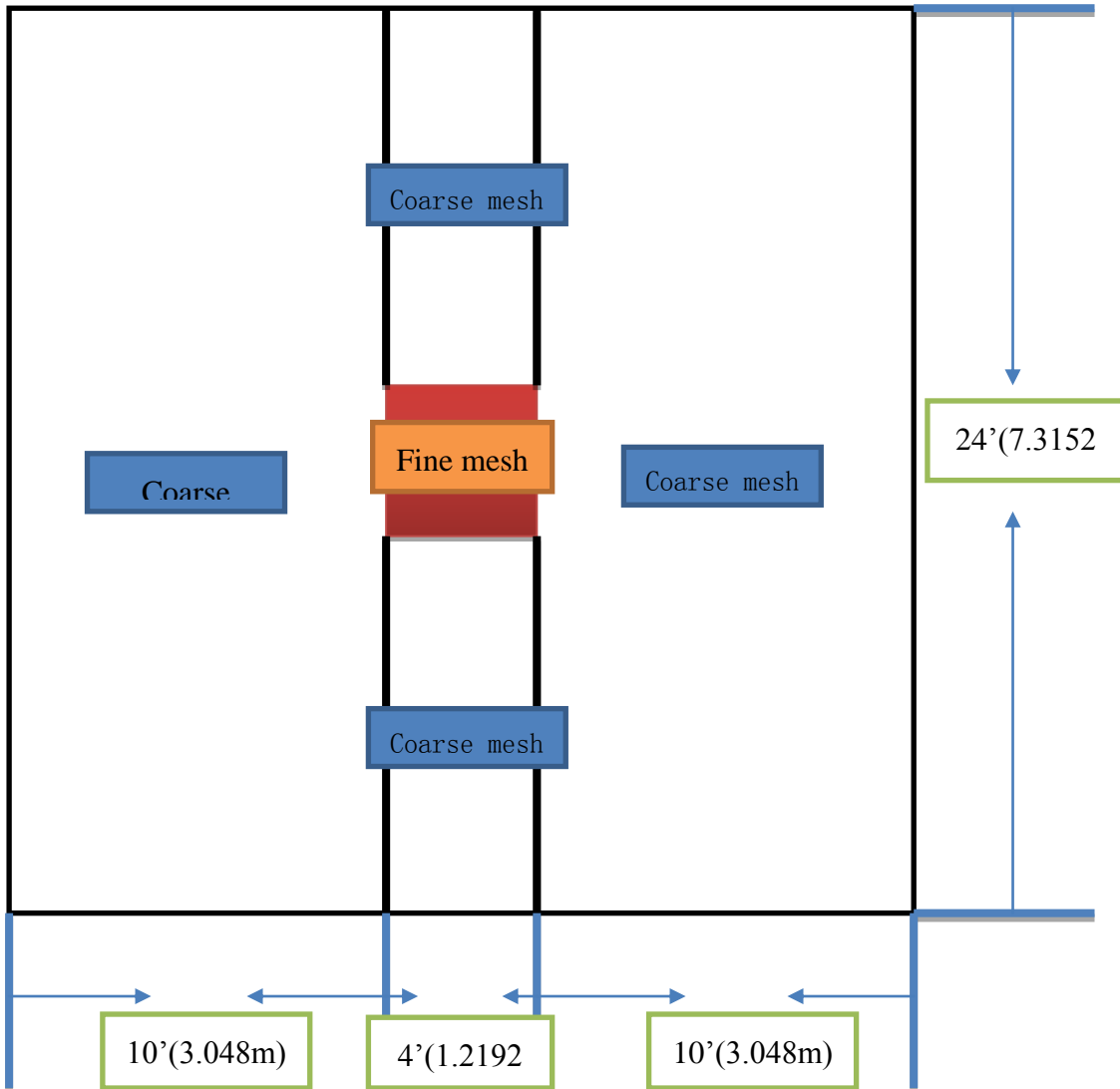

Figure 16 Top View Multi-Mesh

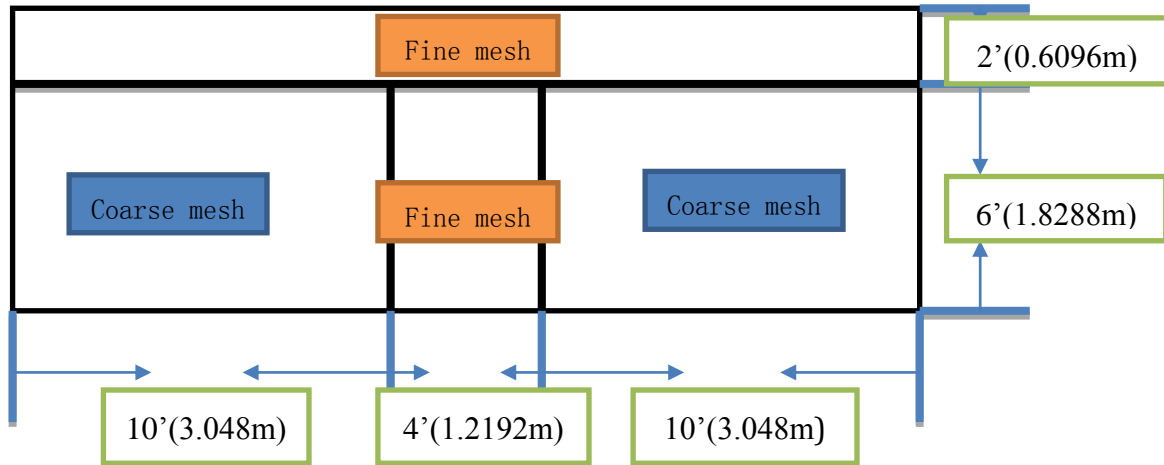

Figure 17 Side View Multi-Mesh

For fine meshes, the cell sizes differed from 3'' (0.076m), 2'' (0.0508m) to 1.5'' (0.04m). For 2'' (0.05m) and 3'' (0.0762m) fine cells, a 1'x1'x1' (0.30m) cell size was used for a coarse mesh. For the 1.5'' fine mesh size, a 0.5'x0.5'x0.5' (0.15m) cell size was used for the coarse mesh cells to avoid a sharp change between fine meshes and coarse meshes.

According to the hrr.csv, we can get the time to reach a steady state.

cell size	runtime(s)	theoretical hrr (kW)	time to be steady(s)	average hrr (kW)	standard deviation(kW)
1.5''(0.0381m)	200	269.6	3	269.91	4.905664
2''(0.0508m)	300	269.6	3.6	269.87	5.270417
3''(0.0762m)	300	269.6	3.61	269.83	3.230555

Table 11 8 ft. Ceiling hrr.csv File

The theoretical heat release rate is calculated by the area and heat release rate per unit area in the .fds files. The average hrr is calculated by the data after the hrr is steady.

According to the average hrr from the simulation, the fire can be considered to be steady after about 4s for all mesh sizes. The standard deviation is less than 2%.

According to the devc.csv, the following temperatures are:

Cell size	1.5''(0.0381m)	2''(0.0508m)	3''(0.0762m)
Distance from the center	Simulation T(°C)	Simulation T(°C)	Simulation T(°C)
2.5'(0.762m)	178.4	178.8	152.6
4.5'(1.3716m)	128.3	129.6	114.2
6.5'(1.9812m)	103.5	105.7	94.4
8.5'(2.5908m)	87.3	90.6	81.5

Table 12 8 ft. Ceiling devc.csv File

The simulation temperatures are the average ceiling temperature calculated by the data after the hrr is steady. To get an appropriate cell size simulation temperature were compared from the different cell sizes.

Cell size	1.5''(0.0381m)	2''(0.0508m)			3''(0.0762m)		
Distance from the center	Simulation T(°C)	Simulation T(°C)	$\Delta T$ between different cells(°C)	Percentage of the $\Delta T$ (%)	Simulation T(°C)	$\Delta T$ between different cells(°C)	Percentage of the $\Delta T$ (%)
2.5'(0.762 m)	178.4	178.8	0.4	0.2	152.6	26.2	14.7
4.5'(1.3716 m)	128.3	129.6	1.3	1.0	114.2	15.4	11.9
6.5'(1.9812 m)	103.5	105.7	2.2	2.1	94.4	11.3	10.7
8.5'(2.5908 m)	87.3	90.6	3.3	3.8	81.5	9.1	10.0
Time	1 week or more	2 to 3 days			1 day		

Table 13 8 ft. Ceiling FDS Run Times

The simulation temperature is calculated from the average temperature of the ceiling temperature after the hrr is steady at different distances.

From the table above, there is little difference between 1.5'' (0.0381m) cell and 2'' (0.0508m) cell, but there is a large difference between the 2'' (0.0508m) cell and 3'' (0.0762m) cell. Considering the time it takes to finish the simulation, the 2'' (0.0508m) cell is the best choice for our simulation.

## Ceiling material choice

The simulation we have finished are as follows:

	Height(m)	Coarse mesh	Fine mesh	HRRPUA (kW/m <sup>2</sup> )	Burner size	Ceiling material
8'3'' ceiling	2.4384	1'(0.3048m)	3''(0.0762m)	725	2'*2'(0.6096m)	Yellow pine
8'3''	2.4384	1'(0.3048m)	3''(0.0762m)	725	2'*2'(0.6096m)	Adiabatic

Table 14 FDS Ceiling Comparison

The properties for yellow pines:

	Density $\rho$ (kg/m <sup>3</sup> )	Heat capacity $C_p$ (kJ/(kg·K))	Conductivity k(W/(m·K))	Emissivity $\epsilon$	Absorption coefficient (1/m)
Yellow pine	640	2.85	0.14	0.9	50000

Table 15 Yellow Pine Properties

According to the hrr.csv, we can get the time to reach a steady state.



Ceiling material	Runtime(s)	theoretical hrr(kW)	time to be steady(s)	average hrr(kW)	standard deviation(kW)
Adiabatic	300	269.6	3.61	269.83	3.230555
Yellow pine	300	269.6	3.60	269.84	3.019422

Table 16 Steady State Times

The theoretical heat release rate is calculated by the area and heat release rate per unit area in the .fds files. The average hrr is calculated by the data after the hrr is steady.

According to the average hrr from the simulation, the fire can be considered to be steady after about 4s for both ceilings. The standard deviation is less than 2%.

According to the devc.csv, we can get the temperature.

Ceiling material	Adiabatic		Yellow pine	
	Simulation T(°C)	Simulation T(°C)	$\Delta T$ between different cells(°C)	Percentage of the $\Delta T$ (%)
2.5'(0.762m)	152.6	150.8	1.8	1.2
4.5'(1.3716m)	114.2	111.3	0.9	0.8
6.5'(1.9812m)	94.4	90.3	4.1	4.3
8.5'(2.5908m)	81.5	76.5	5	6.1

Table 17 Adiabatic vs. Yellow Pine

Due to the small difference in results, an adiabatic ceiling was used in the FDS simulations to reduce the run time.

## **Introduction of MPICH2**

MPICH2 is a portable implementation of MPI, a standard for message-passing for distributed memory applications used in parallel computing. It provides an MPI implementation that can efficiently support different and complicated computations. MPICH2 is a free software and available for Microsoft Windows.

MPICH2 separates the process management and communication. The default runtime environment consists of a set of daemons called mpd. They establish communication among the machines before application process startup. This can help achieve a fast process in parallel jobs [11].

Running the FDS simulations with the help of MPICH2 by parallel computing can save a lot of time to finish the simulation work in computer.

## **Installation of MPICH2 on Windows 7**

This section is about how to install MPICH2 in the Windows environment. This can be completed in either of operating system Windows XP, Vista or 7 [12].

1) Install MPICH2 on the computer using the installer downloaded from the site:

<http://www.mpich.org/static/downloads/1.2/>

2) Install MPICH2 to the default path (usually C:\Program Files\MPICH2 )

- 3) During installation, select MPICH2 to be installed for Everyone.
- 4) Keep the default setting for passphrase during the installation.
- 5) After installing MPICH2 successfully, add rules to the firewall to allow the programs **mpiexec.exe** and **smpd.exe** to communicate through firewall.
- 6) Add the bin folder of MPICH2 (usually C:\Program Files\MPICH2\bin) to PATH in Environment Variable.
- 7) Open an admin command prompt by right-clicking on the command prompt icon and selecting run as administrator. In the command prompt type the following commands in sequence:

smpd -install

mpiexec -remove

mpiexec -register

mpiexec -validate (it should return success)

smpd -status (it should return ' smpd running on <hostname>' )

If the last two commands are successful, then we can run FDS simulation in parallel.

### **Coding and running FDS simulation**

- 1) Add MPI\_PROCESS code in the **.fds** file and save.

#### **For example:**

&MESH ID='UP1', IJK=X,X,X, XB= 0,1 0,1, 0,1, MPI\_PROCESS=0 / GRID 1

&MESH ID='UP2', IJK=X,X,X, XB= 0,1 0,1, 0,1, MPI\_PROCESS=1 / GRID 2

&MESH ID='RGHT1', IJK=X,X,X, XB= 0,1 0,1, 0,1, MPI\_PROCESS=2 / GRID 3

&MESH ID='RGHT2', IJK=X,X,X, XB= 0,1 0,1, 0,1, MPI\_PROCESS=3 / GRID 4

- 2) Open an admin command prompt by right-clicking on the command prompt icon and selecting run as administrator. In the command prompt type the following commands:

**cd path of the .fds file** (e.g. **cd C:\Users\admin\Desktop\MPI**), press Enter button.

- 3) Type the following commands in the same command prompt:

**mpiexec -n 2 -localonly fds5\_mpi.exe filename.fds** (here 2 means the number of cores of the computer system)

(e.g. **mpiexec -n 2 -localonly fds5\_mpi.exe 10X10X8-FIRE-CENTERED.fds**), press Enter button.

- 4) Then the simulation begins to run.

#### **FDS Validation:**

After running our FDS simulations it is necessary to make sure that results we got are accurate and consistent with the findings of other similar simulations. To find simulations consistent with our own, we made use of the NIST publication, *Fire Dynamics Simulator (Version 5) Technical Reference Guide Vol. 3: Validation*. Within the validation guide there were many examples of tests conducted to measure the accuracy of FDS in different scenarios, such as the test conducted by Hurley and Munguia which looked at temperatures and activation times along the ceiling outside the fire plume [13]. While Hurley and Munguia's analysis of response times of heat detectors in FDS focus mostly on activation times, they still have described their room set up and temperature findings which we can use to help validate our findings [5].

To first determine if this analysis is acceptable to use for validating our results we first need to look at the similarities and differences between the two simulations. There are a few differences

between the two simulations, the first being that Hurley and Munguia use a  $t^2$  growth rate for their fires [5]. However it should be noted that for ceiling heights of 3.0m and 4.6m the fire grew until it reached a size of 1055 kW and 2100 kW respectively and then was held steady, all other ceiling heights had continues fire growth [5]. A second difference is the burner dimensions, their burner was slightly larger than our own, their burner measured 1m by 1m. Also, they used a 10cm by 10cm grid for their fine mesh, for our own simulations our fine mesh was made up of 2cm by 2cm grids. They used 10cm based on their assumptions that it would lead to the greatest accuracy based on the amount of time it took to simulate. Lastly, in their simulations they used a 36m by 36m enclosed room for the tests, but they also included a ventilation system so that no smoke layer would build up [5]. We also made sure that no smoke layer could build up in either our simulations or tests. More importantly though are the similarities between the two simulations. Both ours and their simulations used the same flat ceiling heights, the same multi-mesh organization, and both made sure to stop any smoke layer build up [5].

Below is table that combines Hurley and Munguia's temperature results and combines them into one visual.

Ceiling Height	Temperature Ratings
3.0m	The predicted gas temperatures were higher than what was measured in the physical tests.
4.6m	Predicted gas temperatures were generally within the range of experimental uncertainty when outside the fire plume
6.1m & 7.6m	Predicted gas temperatures were within the range of the experimental uncertainty when outside the fire plume are
10.7m & 12.2m	Predictions were generally within the range of data found in the experiments

**Table 18 Ceiling Height vs. FDS Accuracy**

[5]

Looking at results from Hurley and Munguia, it appears that as the ceiling height increases, the results from FDS become closer to those found from the experiment. They also found that temperatures outside the fire plume region were much closer to the actual temperatures measured during the experiment than the temperatures within the fire plume region [5]. While we were not able to conduct physical tests for ceiling heights greater than 2.4m (8ft) we did find similar results when comparing our FDS results to those of our experiments. In Hurley and Munguia's experiments and simulations a thermocouple was placed at 100mm (4in) below the ceiling at distances of 2.2m (7.1ft), 6.5m (21.2ft), and 10.8m (35.4ft). For our simulations we placed thermocouple trees at 0.8m (2.5ft), 1.4m (4.5ft), 2.0m (6.5ft), and 2.6m (8.5ft) from the center of the burner. If we look at the difference between our 2.0m trees at 100mm below the ceiling temperature readings from our simulation and experiment we get a difference of about 23°C or 28%. Like the findings in Hurley

and Munguia’s analysis for a similar ceiling height, and similar distance from the burner our simulated gas temperatures are higher than the recorded temperatures of our experiments. Below is a table that shows the percent difference between our simulated temperatures and actual temperatures of our thermocouples 100mm from the ceiling, the same height as the measured temperatures in Hurley and Munguia’s experiments.

	2.5 ft. Tree		4.5 ft. Tree		6.5 ft. Tree		8.5 ft. Tree
Distance from ceiling (in)							
4	33%		28%		28%		29%
	36°C		27°C		23°C		22°C

**Table 19 Temperature Difference According to Distance from Fire**

In all of the temperature readings, the simulated gas temperatures were greater than the actual recorded temperatures by over 25%. This data is consistent with the findings of Hurley and Munguia and helps support our findings for our FDS simulations.

## **Appendix C: LHD Installation Guide**

For our third and fourth experimental configurations we needed to test linear heat detection (LHD) cable activation times based on different heights from the ceiling. The first step to testing was deciding on which LHD cable we were going to use for our tests. We chose Safe ThermoCable LHD Cable manufactured by Safe Fire Detection Inc., the cable we used was designed to activate at 155°F (68°C). We used two different configurations for our LHD cable for conducting our tests. In the first test with LHD cable we created a 12'x12' perimeter with the LHD cable and our burner in the center. The LHD cables were set at 2", 4", 6", and 20" from the ceiling, our ceiling was 8' from the top of the burner. We made these decisions based on our thermocouple temperature readings from our previous two tests. None of the LHD cables activated during this test, for the fourth test we decided to create a smaller perimeter with the LHD cable so that we could get the cables to activate. For the second test we kept all the same heights for the LHD but we now had a 6'x6' LHD perimeter with our burner still located in the center. The smaller box led to three cables activating, the cables that were 2", 4", and 6" from the ceiling all activated in order from closest to the ceiling to the farthest from the ceiling. Our LHD cables were connected to an extension wire that ran to our DAQ box. From the DAQ box we were able to tell when each cable activated, more information on this can be found in the LabVIEW appendix.





UL C-ULS FM APPROVED MEA  
ISO 9001 Registered

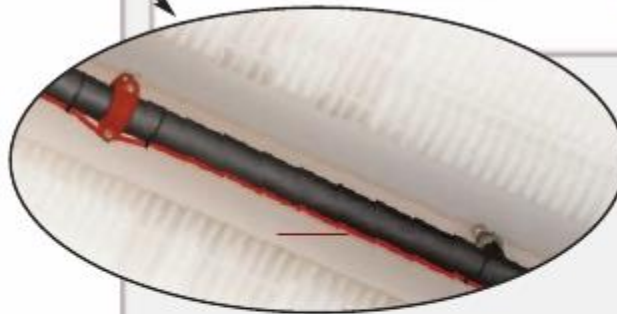
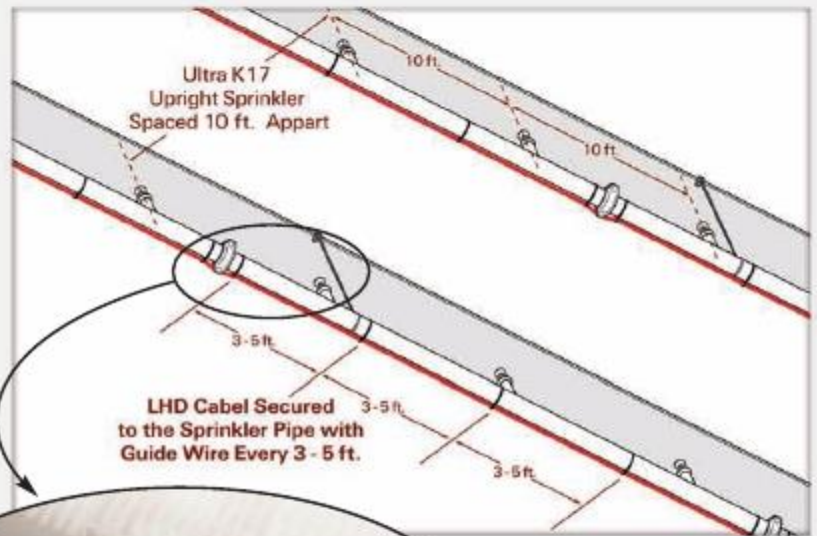

**Quell**<sup>TM</sup>  
FIRE SPRINKLER SYSTEMS  
A Greater Degree of Fire Protection

*An essential part of a Quell™ designed fire sprinkler system*

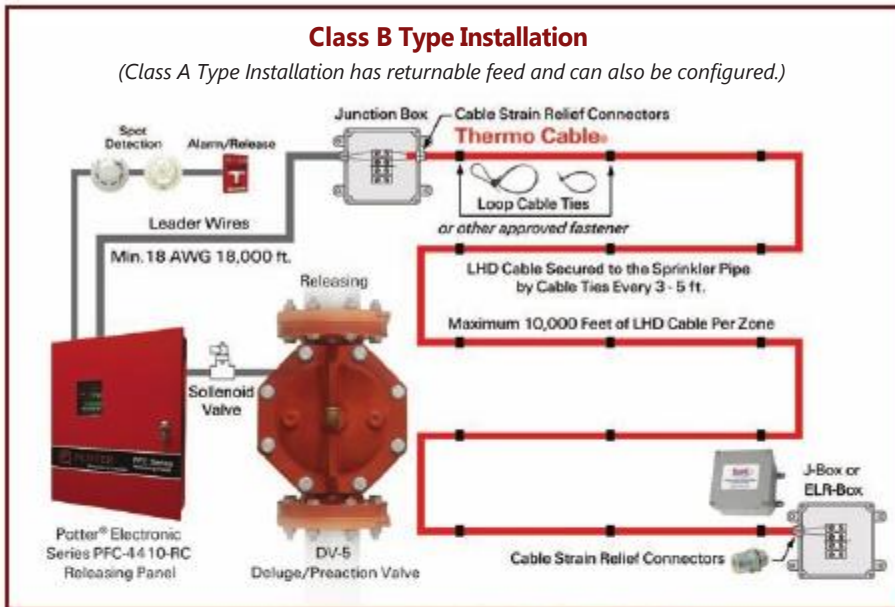

*Linear Heat Detection Cable allows a Quell designed fire sprinkler system to be more efficient by quickly recognizing the fire, and conveying the information back to the fire alarm panel.*

## LHD CABLE INSTALLATION ACCESSORIES

### Double Loop Cable Tie

Fits 3/4" to 2" sprinkler pipe  
Fits 2-1/2" to 3-1/2" sprinkler pipe



### Single Loop Cable Tie

Fits 4" to 6" sprinkler pipe



### Junction / ELR-Box

NEMA 4X moisture proof standard junction box, with crew terminal strip, also used for all outdoor splices.  
Dimensions: 4" x 4" x 2"



### Cable Strain Relief Connector

One required for each Junction/ELR-Box, HD-Junction/ELR-Box and HD-ELR-Box. Two required for all outdoor splices.



### Splicing Block

Two point with screw terminals.



### Low Temperature Splicing Tape

Black



### Splicing Tape

White, Red, Blue



### Sealant Tape

For weatherproof splices.



## TYCO ELEMENTS OF A QUELL DESIGNED FIRE SPRINKLER SYSTEM



SprinkFDT-Q™ Software



Ultra K17 286° Sprinkler  
16.8 K-factor



QRS Electronic  
Accelerator



DV-5  
Deluge/Preaction Valve

## A Quell designed sprinkler system provides A Greater Degree of Fire Protection.

Patent-pending Quell designed fire sprinkler systems are the first of their kind for cold storage, outdoor and unheated warehouse facilities.

**Tyco Fire & Building Products**

Technical Services

Phone: 800-381-9312

Fax: 800-791-5500

[www.Tyco-Fire.com](http://www.Tyco-Fire.com)

**tyco** / Fire & Building  
Products



## **Appendix D: Test Plan**

### **PHYSICAL MODELS:**

For physical models we are currently planning for a total of four tests, all on 8' ceilings. Our first and second tests will make use of thermocouples, these will provide us with needed temperature readings at various heights and distances to give us better understanding of the ceiling jet and will validate our ceiling jet equations. To validate our equations we will hang several thermocouples at varying vertical distances from the ceiling and horizontal distances from the center of the fire plume.

After our first two tests are complete we will install our LHD Cable at varying heights. The heights will be decided on after looking over the temperature readings from our thermocouples from the first two tests. Both test three and four will make use of LHD cable and thermocouples.

### **EXPERIMENTAL CONFIGURATIONS:**

We have a total of four physical tests planned. We have multiple tasks we hope to achieve through these planned tests. From the first two tests, the thermocouple tests, we are looking at obtaining temperature readings that will help validate our ceiling jet thickness that we calculated. From the first two tests we also hope to find appropriate heights at which to hang our LHD cables. From our third and fourth we will be looking at activation times for our LHD cables. These times will give us evidence that either supports or argues the 20 in. minimum distance requirement.

In all of our experimental configurations, there will be no walls and only a 24'x24' ceiling. This will allow for the smoke to rise without the buildup of a smoke layer. In our first

test the only devices we will be using for measurements are thermocouples. We are limited to a total of 32 thermocouples per test, to abide by this constraint we will have a total of four trees. Two will be short (4.5 in.) and two will be long (10 in.), the short trees will have a total of five thermocouples per tree starting at .5 in. from the ceiling and ending at 4.5 in. from the ceiling. The short trees will be used in all four of our planned tests. The long trees will have a total of 11 thermocouples per tree starting at 0 in. from the ceiling and ending at 10 in. from the ceiling. The long trees will be used in all four of our planned tests. In the first test will place a short tree at 2.5 ft. and 4.5 ft. from the center of our burner. On the opposite side of the burner we will place a long tree at 2.5 ft. and 4.5 ft. from the center of the burner. This allows for us to take temperature readings every half inch down to five inches without the thermocouples interfering with one another. A diagram of the first experimental configuration can be found below.

**Experimental Configuration 1**

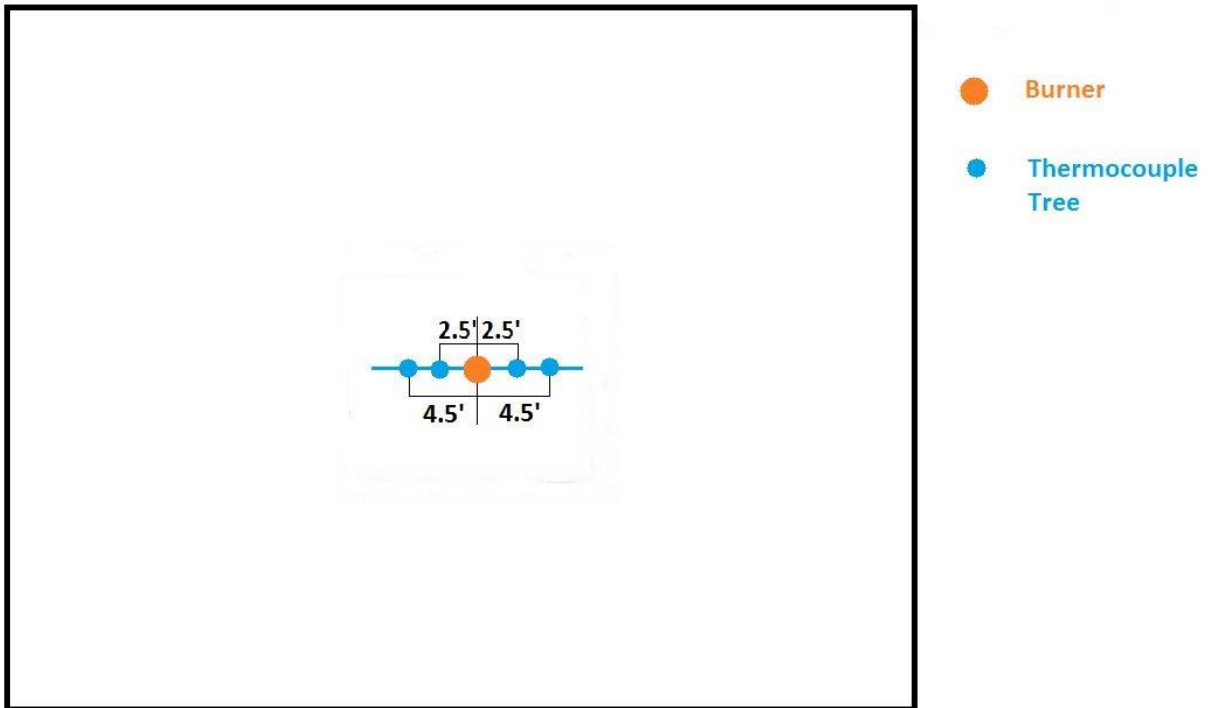

Figure 18 Experimental Configuration 1

In our second experimental configuration we will use the same trees as in the first experimental configuration, the only exception is that they will be spaced further from the center of the burner. In the second experimental configurations we will place a short tree at 6.5 ft. and 8.5 ft. from the center of the burner. On the opposite side of the burner we will place a long tree at 6.5 ft. and 8.5 ft. from the center of the burner. Like the first test the goal here is to be able to acquire enough data to graph an accurate ceiling jet with a defined boundary layer and free jet. A diagram of the second experimental configuration can be found below.

### Experimental Configuration 2

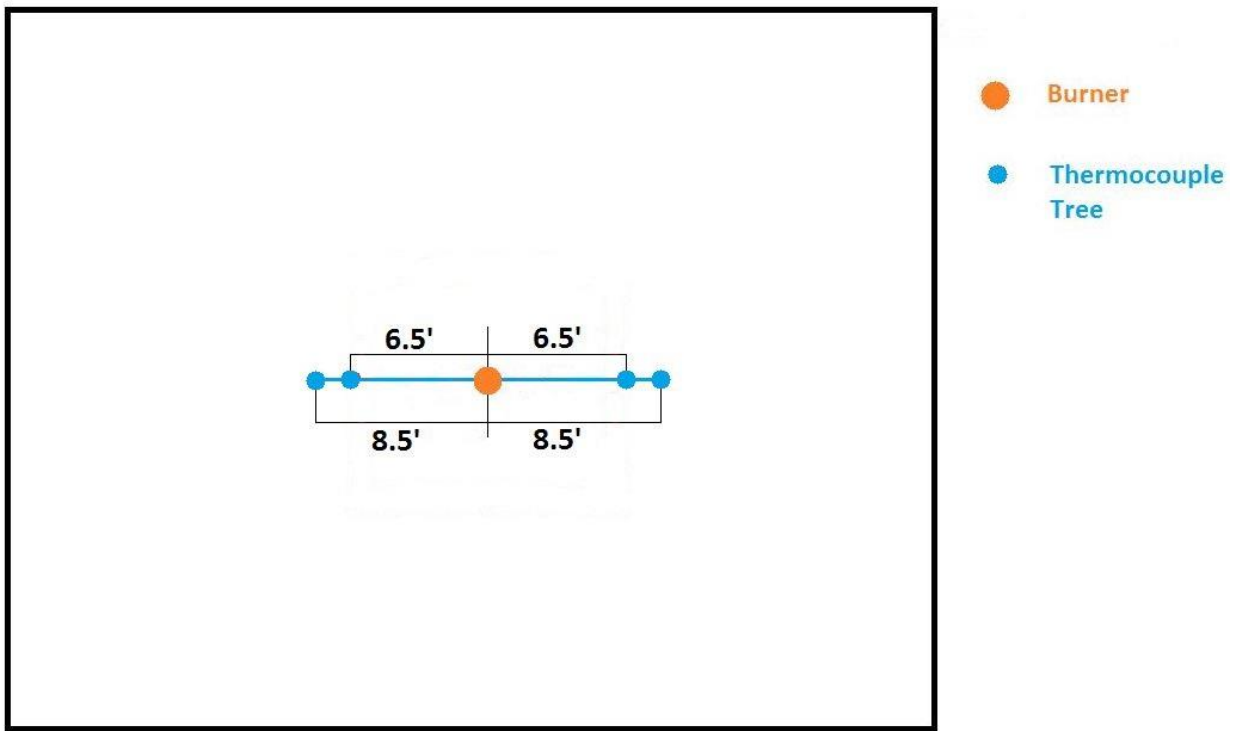
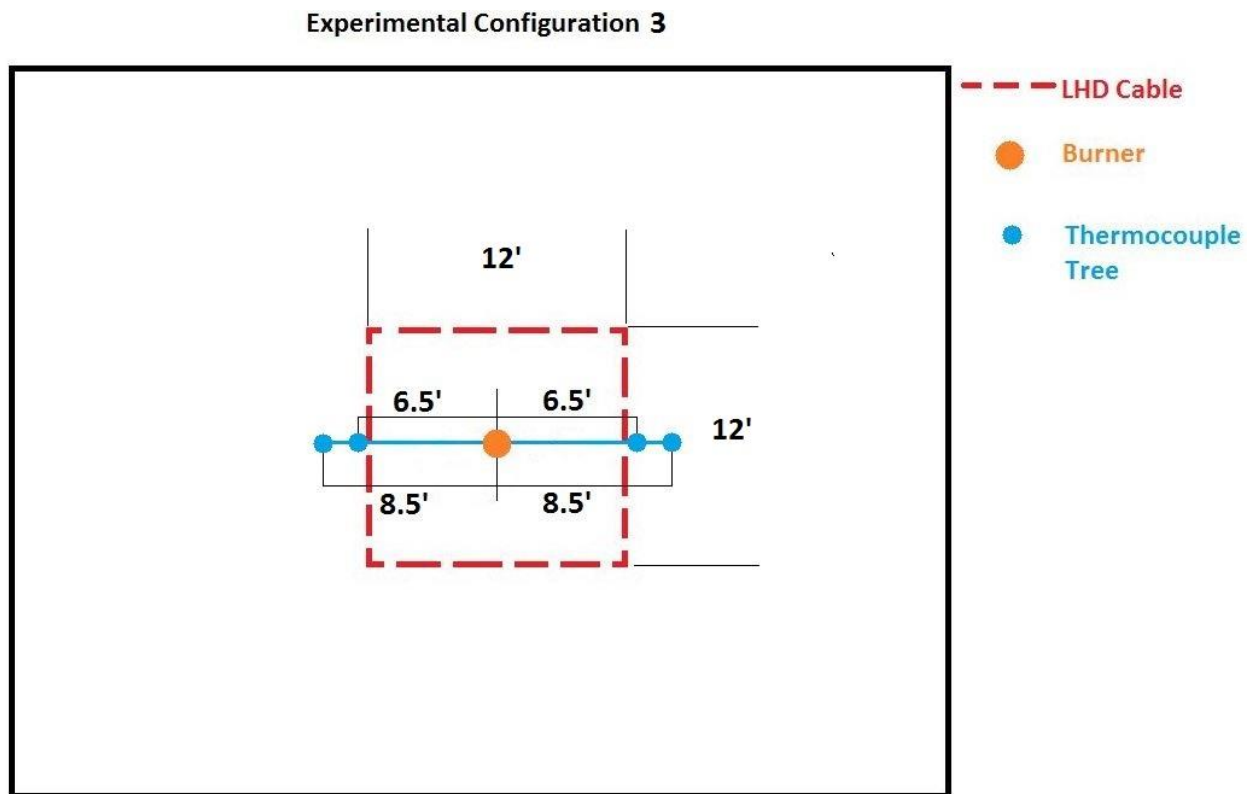

Figure 19 Experimental Configuration 2

Our third experimental configuration will again consist of four thermocouple trees, however, the focus of this test and the following will be on the activation times of the LHD cables. For the third test will set up the LHD cables in 12'x12' square around the burner, the burner will be located directly in the center of the LHD square. For the third test we also kept the

thermocouple trees at 6.5 ft. and 8.5 ft. from the burner center for both the short and long trees. The third and fourth tests will each have a total of four LHD cables due the limited channels available for the computer. The heights at which the LHD cables are suspended can be found in the ‘LHD SUSPENION’ section. A diagram of experimental configuration 3 is located below.



**Figure 20 Experimental Configuration 3**

For our fourth and final experimental configuration we will create a smaller LHD box to ensure activations. For the fourth test we will create 6’x6’ LHD box rather than the 12’x12’ box from the third test. We will also move the thermocouple trees in to the 2.5 ft. and 4.5 ft. locations for the short and long trees. A diagram of the fourth experimental configuration can be located below depicting the location of the devices in use.

#### Experimental Configuration 4

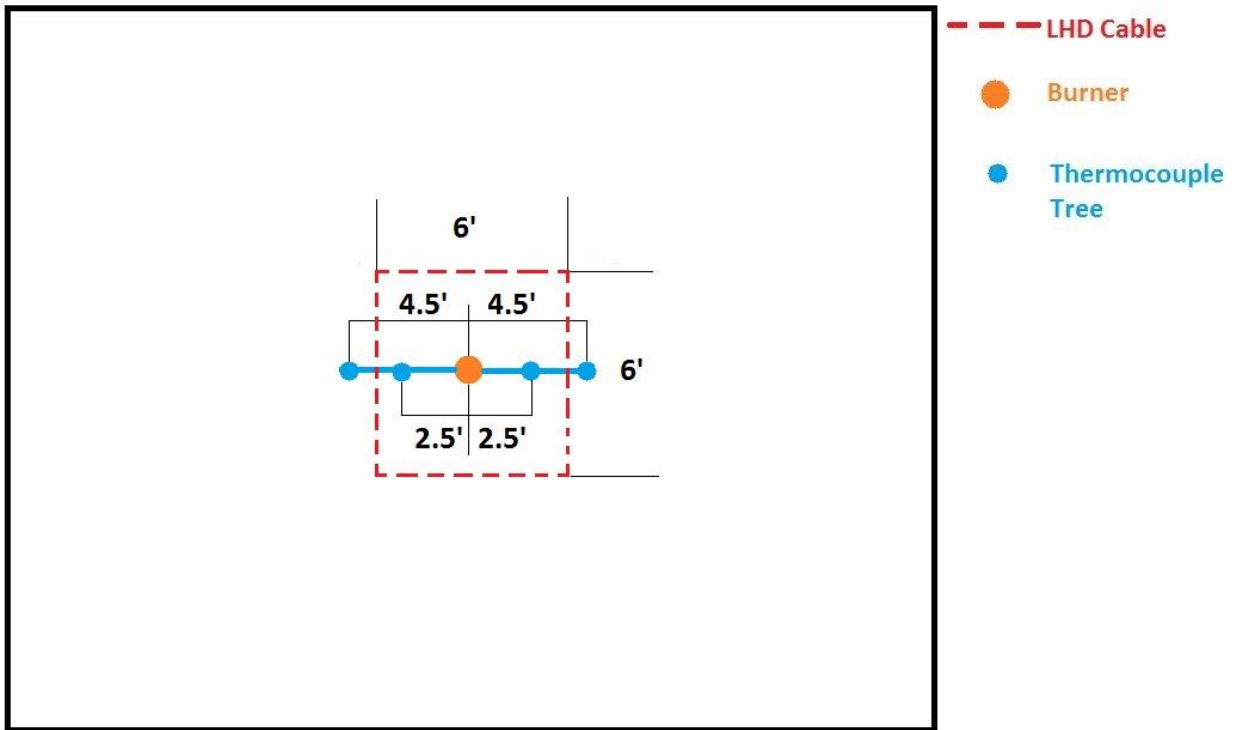

Figure 21 Experimental Configuration 4

#### LHD TO BE USED:

To validate our FDS simulations we will be conducting physical models with linear heat detectors and measuring the activation times. For our physical models we will be using Safe ThermoCable's LHD cables sold by Tyco. We will be using cables rated to activate at a temperature of 155°F (68°C). The 155°F rated LHD cables are listed as the most commonly used cables. These cables are the lowest rated temperature suitable sold by Safe ThermoCable, the low temperature rating should produce early and guaranteed activation times.

#### LHD SUSPENSION:

For our third and fourth tests we will need to suspend the LHD cables above the flame. To do so we will use threaded rods, these threaded rods will have U-shaped brackets to hold the



LHD in place. Due to the rod being threaded the height of the brackets can be easily adjusted. The rods are held in place by a base plate that is secured with screws on the ceiling. For our third test we will start with 12'x12' LHD box with a rod every 6 ft. for support to reduce the sag in the cables. We will decide on the heights at which to hang our LHD cables after our first two tests are completed and we have a good idea of where the boundary layer is located and how thick the ceiling jet is. However, it is likely that we will have one LHD cable located 20 in. from the ceiling because of the regulations set by NFPA 72. For our fourth test will move our LHD box in so that it is a 6'x6' box with supports every 3 ft. so that we are guaranteed activations. Again, the heights will be decided after our first two tests but it is likely that we will still keep an LHD cable at 20" from the ceiling.

#### **DATA TO BE GATHERED:**

From our FDS models we will be collecting the temperatures within the ceiling jet and just outside of it in an attempt to graph them and show the temperature profile. We will be conducting the same data gathering for our physical models but in our second two tests we will also be looking at activation times for our LHD.

To start gathering data we started with Alpert's ceiling jet equations. Using these equations we can find appropriate HRR for fires that will be used. An excel chart with the data input and received from the equations can be found in attached. After the ceiling jet equations are complete we will then go on to FDS modeling for our fire scenarios. We will use the FDS models to verify our ceiling jet equations, once our FDS simulations are complete we can then go on to physical modeling to try and verify all of our previously gathered data.

The main goal of our ceiling jet equations is to give us an appropriate HRR for our FDS and physical models. From here we can create our FDS models in an attempt to find the ceiling jet temperature profile. Along with our FDS models, the goal of our physical model is to obtain the ceiling jet temperature profile. We will also conduct research on Motevalli and his work concerning ceiling jets to help verify our findings on ceiling jet temperature profiles.

## **Appendix E: LabVIEW**

To collect the needed data from our model tests we needed a data acquisition system. We used National Instruments' LabVIEW, a graphical programming platform [10]. It allowed us to see the real time temperature readings of our thermocouples and when our LHD cables activated. When the tests were finished it also provided us with Excel charts with all the data we collected, such as thermocouple temperature readings and LHD activation times.

For our tests we set LabVIEW to take a temperature reading every .25 seconds, with our tests running for about 700 seconds it gave us about 2800 data points for our thermocouple temperature readings. In our LabVIEW Front Panel and Excel our temperature readings were in degrees celsius. Also, on the right-hand side of the Front Panel are our LHD activation readings. When there is no contact between between the LHD wires within the jacket the reading is 10,500 however, when the polymer seperating the wire breaks down due to heat and the wires come in contact the reading in the Front Panel will be 0.

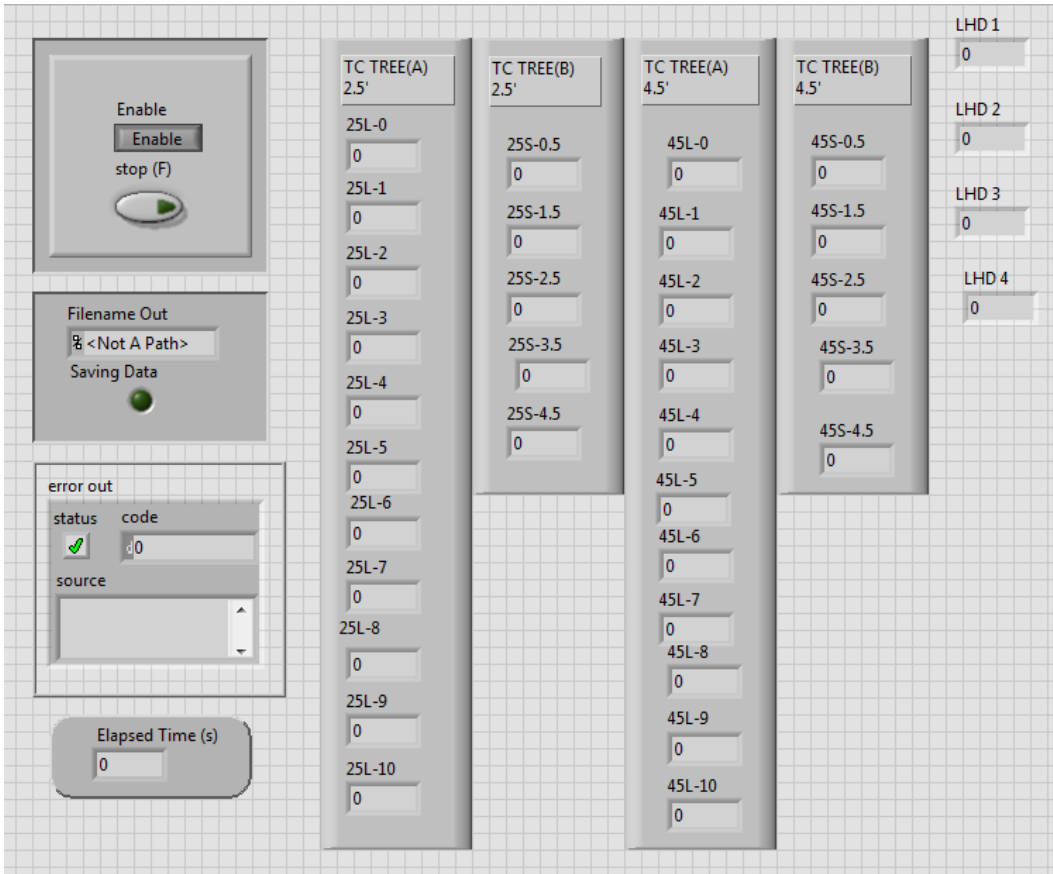

Figure 22 LabVIEW Front Panel

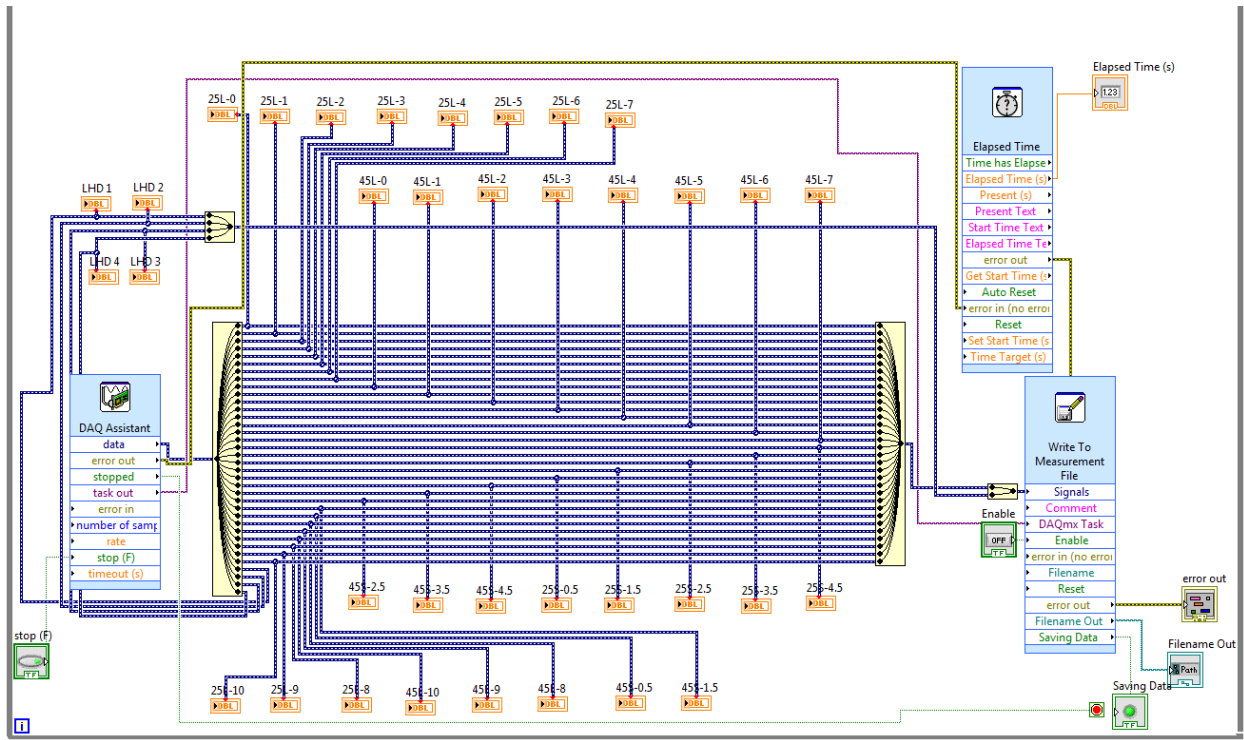

Figure 23 LabVIEW VI

## **Appendix F: Thermocouples**

Before any physical testing could be done we first needed to construct our thermocouple trees for temperature readings. For our testing we used K-type 24 gauge thermocouples from OMEGA Engineering inc.. These thermocouples are rated to have a degree error of about  $\pm 2.2^{\circ}\text{C}$  or 0.75% [2]. After cutting the thermocouple wire to length, soldering the ends, and constructing our necessary thermocouple trees we conducted oven tests on all of our thermocouples. The purpose was to make sure that our soldering job would be able to stand up to the heat that would be experienced during the test without breaking, to make sure the our LabVIEW VI was functioning correctly, and to check the degree error that was present in our thermocouples.

The oven tests were conducted from a range starting at  $100^{\circ}\text{F}$  and ending at  $520^{\circ}\text{F}$ , the temperature was increased in 20 degree intervals after the ambient temperature of the oven had stabilized for approximately 30 seconds. None of the thermocouples failed due to the heat experienced during the oven tests, however, during our actual model testing one thermocouple connection failed due to the stresses put on the solder during the changes in locations along the ceiling. After analyzing the LabVIEW data recorded during the tests it was evident that our thermocouples were within the  $\pm 2.2^{\circ}\text{C}$  of error. No correction factor was applied to our thermocouple readings and it possible that error in temperature readings can be attributed to the error present in the thermocouples.

## **Appendix E: Test Results**

### ***Data processing***

*From the whole 4 tests, there are 4 Excel sheets respectively containing the test data. Carry out the data processing as the following:*

1. *Select steady-state temperature data*

*There are some test error factors that have influenced the fire test, such as air motion in the test area even though all doors and windows are closed and the gas burner may not diffuse flames effectively. In result, there are some unreliable data that show the temperatures went down obviously after the fire achieved a steady state, which is impossible in a perfect test environment. Also another important factor is the oxygen content in the test room that is nonnegligible because the test ran for about 10 minutes.*

*Considering these, it is reasonable to select the steady-state temperature data based on an average temperature each thermocouple achieved when it turned into steady state, and get rid of the other data.*

*By using the “Filter” function in Office Excel, steady-state temperature data for thermocouples in every position are selected.*

2. *Calculate the average temperature*

*Through filtering the data, the rest data are in a steady state. Use the “AVERAGE” command in Excel to get the average values of the selected temperatures.*

### **Radiation balance**

The thermocouples had a radiation balance with the environment during the test, which influenced the temperatures collected. To get accurate and reliable test results, it is necessary to calculate a radiation balance compensation for thermocouples.

The radiation balance processing is shown below:

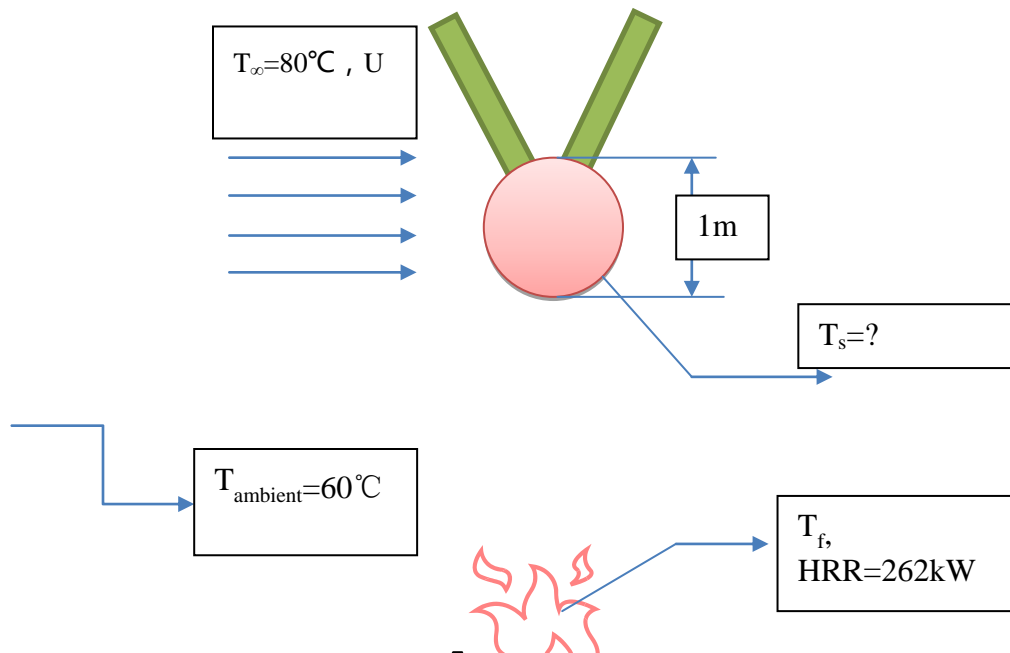

**Figure 24 Radiation Balance**

Known:  $d=1\text{mm}$ ,  $T_\infty=35^\circ\text{C}$ ,  $\text{HRR}=262\text{kW}$ ,  $r=0.762\text{m}(2.5\text{ft})$ ,  $1.3716\text{m}(4.5\text{ft})$ ,  $1.9812\text{m}(6.5\text{ft})$ ,  $2.5908\text{m}(8.5\text{ft})$ ,  $H=2.4384\text{m}(8\text{ft})$

Find:  $T_s$

Assumption:

1. The bead of the thermocouple is blackbody.



2. Negligible heat conduction along the thermocouple wire.
3. The lumped analysis can be used to the bead of the thermocouple.
4. Negligible radiation between the room and the thermocouple.
5.  $T_s \approx 80^\circ\text{C}$

Solution:

$$U = \frac{0.195Q^{1/3}H^{2/3}}{r^{5/6}} \text{ for } r/H \geq 0.15 \quad [6]$$

R(m)	U(m/s)
0.762m(2.5 ft)	2.44
1.3716m(4.5 ft)	1.50
1.9812m(6.5 ft)	1.10
2.5908m(8.5 ft)	0.88

Table 20 Maximum Velocity at Radial Distances

$$\beta = \frac{1}{T} \text{ for gas } g = 9.78 \text{ m/s}^2$$

$$T=350\text{K}, \nu = 20.76 \times 10^{-6} \text{ m}^2/\text{s}, \alpha = 0.2983 \times 10^{-4} \text{ m}^2/\text{s } k = 0.03003\text{W/mK} \quad [14]$$

$$Ra_D = \frac{g\beta(T_s - T_\infty)d^3}{\nu\alpha} \quad [7]$$

$$Ra_D = 2.68$$

$$\overline{Nu}_D = 0.16Ra_D^{1/3}, Ra_D < 2 \times 10^8 \quad [7]$$

$$\overline{Nu}_D = 0.22$$

$$\bar{h} = \frac{\overline{Nu}_D k}{d} = 6.61[85]$$

$$\sigma(T_s^4 - T_{ambient}^4) = \bar{h}(T_\infty - T_s)$$

$$T_s = 345K$$

Temperature compensation due to radiation:

$$\Delta T = 353 - 345 = 8K = 8^\circ C$$

Let  $T_s \approx 72^\circ C$ , double check and irritate,

$$Ra_D = 2.35$$

$$\overline{Nu_D} = 0.21$$

$$\bar{h} = \frac{\overline{Nu_D} k}{d} = 6.31[85]$$

$$\sigma(T_s^4 - T_{ambient}^4) = \bar{h}(T_\infty - T_s)$$

$$T_s = 343K$$

So Temperature compensation due to radiation:

$$\Delta T = 353 - 343 = 10K = 10^\circ C$$

So it is reasonable to add the radiation balance temperature compensation of  $10^\circ C$  to the former average temperature.

### **Temperature profiles refinement**

Draw graphs with all the processed data, then fit a curve to match the results, which makes the test results more look like the known shape of ceiling jet profile.

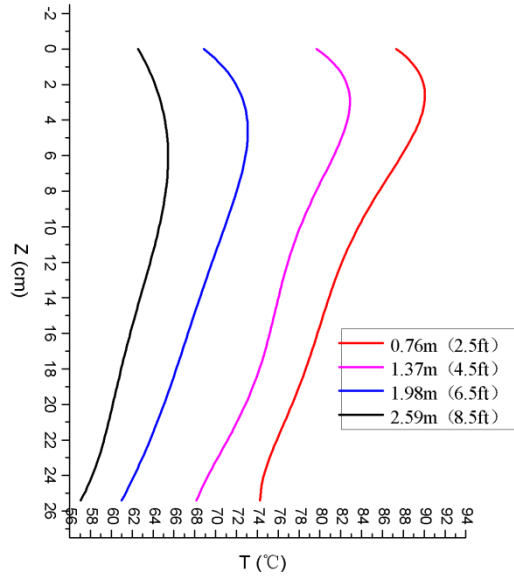

Figure 5 Test 1 & 2 Temperature Profiles

After all the processing work, there are four lines marked different colors in one chart, as showed above. Though the temperature profiles of these four are different, the fact is that the boundary layers are similar in shape of graph.

### Repeatability

The repeatability test results are shown in charts below.

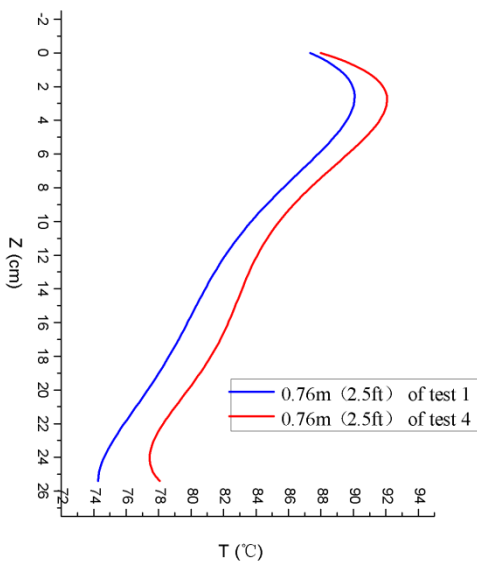

Figure 25 Temperature Profiles 0.76 m

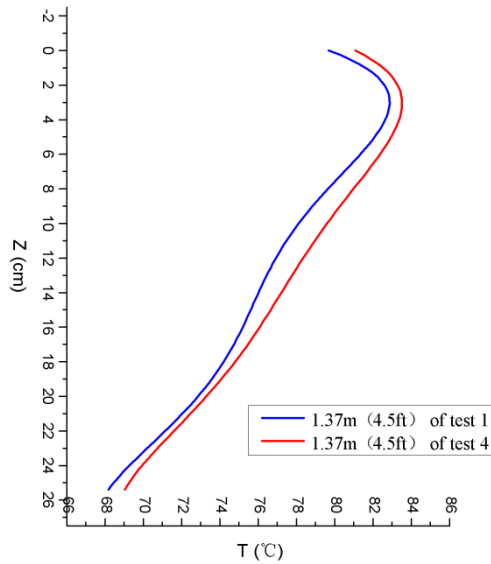

Figure 26 Temperature Profiles 1.37 m

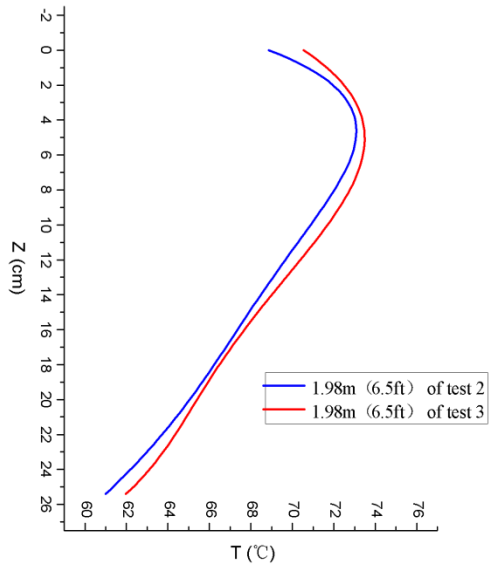

Figure 27 Temperature Profiles 1.98 m

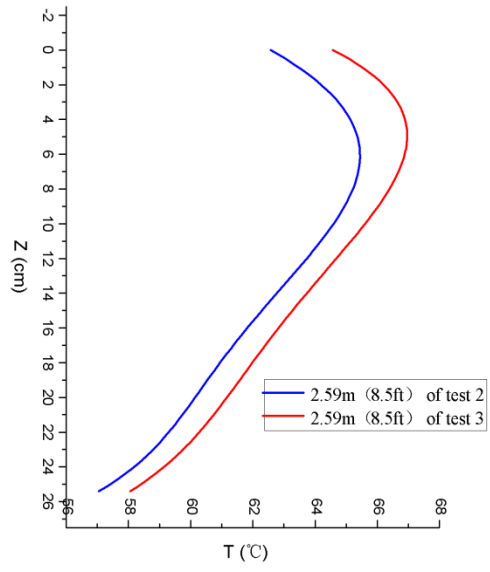

Figure 28 Temperature Profiles 2.59 m

## Appendix H: Final Presentation



**Linear Heat Detection  
Placement**

Liaoyuan Zhao, Song Chen,  
and Tyler Faszewski

**tyco**  
Fire Protection Products

### // Topics

- // Background
- // Introduction to Linear Heat Detection
- // Project Goals
- // Test Details
- // FDS Simulations
- // Test Results
- // Analysis
- // Validation
- // Conclusion
- // Future Work

## // Background

//NFPA 72 requires that the LHD cannot be installed more than 50.8cm (20 inches) below the ceiling

//NFPA 72 requirements have not been validated

Company Confidential

tyco  
Fire Protection Products

3

## // Linear Heat Detection (LHD)

// Consists of

- Chemical resistant protective out jacket
- Two wires, each insulated with a heat sensitive polymer jacket

// Temperatures include:

- 68° C (155° F)\*
- 78° C (172° F)
- 88° C (190° F)
- 105° C (220° F)

\* Typical Temperature

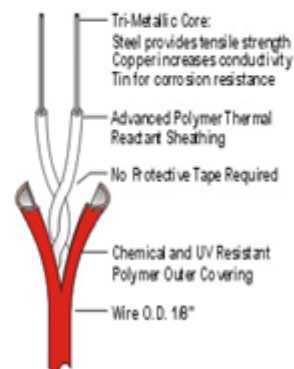

Company Confidential

tyco  
Fire Protection Products

4

## // Linear Heat Detection Set Up

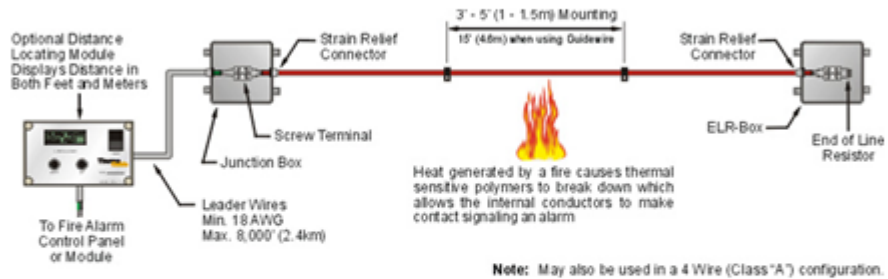

Company Confidential

tyco  
Fire Protection Products

## // Project Goals

### // Use physical models and literature

- investigate the ceiling jet in an attempt to understand NFPA 72 requirements

### // Use FDS

- simulate ceiling jet
- compare them with our findings

### // Use the test, simulations and literature

- find the appropriate installation heights for LHD

Company Confidential

tyco  
Fire Protection Products

## //HRR

//To decide a proper heat release rate, we used the Alpert's equations for steady state fire

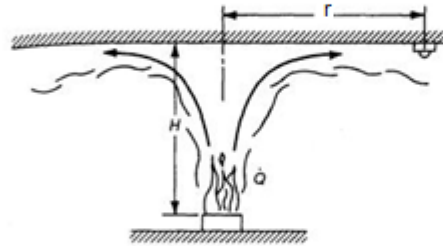

$$T - T_{\infty} = \frac{5.38(\dot{Q}/r)^{2/3}}{H} \text{ for } r/H \geq 0.18$$

Company Confidential

tyco  
Fire Protection Products

7

## //HRR

//According to the LHD activation temperature (68°C), we set the  $T=68^{\circ}\text{C}$  at the corner (2.59m or 8.5ft) in the figure below

$$T - T_{\infty} = \frac{5.38(\dot{Q}/r)^{2/3}}{H} \text{ for } r/H \geq 0.18 \quad \Rightarrow \quad \dot{Q} = \frac{(T - T_{\infty})^{3/2} H^{3/2}}{5.38^{3/2}} r$$

//For ceiling of 2.44m (8 feet), the HRR is 262kW

//To achieve a 262kW propane fire, a flow rate of 190 L/min was used

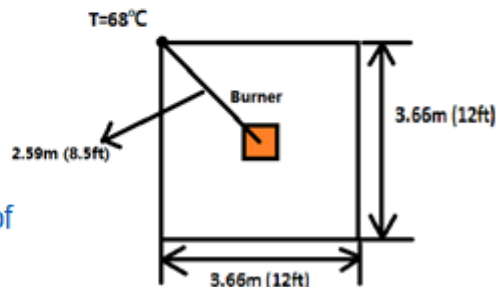

Company Confidential

tyco  
Fire Protection Products

8



## // Gas Burner

// Ring burner with rocks on it to produce diffusional fire  
// 0.61m\*0.61m (2ft\*2ft)



Company Confidential

**tyco**  
Fire Protection Products

2

## // Test 1&2

// To get the temperature profiles at different distances from the center

- 0.76m (2.5ft)
- 1.37m (4.5ft)
- 1.98m (6.5ft)
- 2.59m (8.5ft)

// To figure out the proper heights for LHD locations

// To validate the FDS simulation results

Company Confidential

**tyco**  
Fire Protection Products

10

## // Test 1 Configuration

// To get the temperature profiles at 0.76m (2.5ft) and 1.37m (4.5ft)

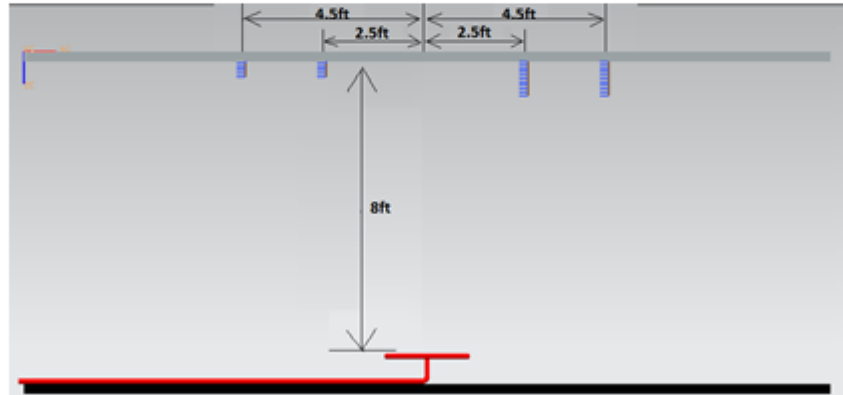

Company Confidential

tyco  
Fire Protection Products

11

## // Test 1 Configuration

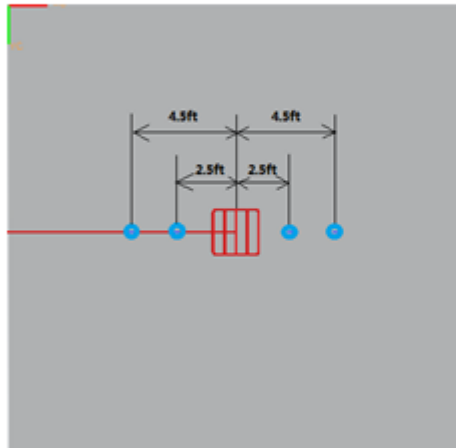

Company Confidential

tyco  
Fire Protection Products

12

## // Thermocouple Trees

// Long tree: 11 thermocouples // Short tree: 5 thermocouples

- 0 to 25.4cm (10in)
- every 2.54cm (1in)



- 1.27cm (0.5in) to 11.43cm (4.5in)
- every 2.54cm (1in)



Company Confidential

tyco  
Fire Protection Products

12

## // Test 2 Configuration

// To get the temperature profiles at 1.98m (6.5ft) and 2.59m (8.5ft)

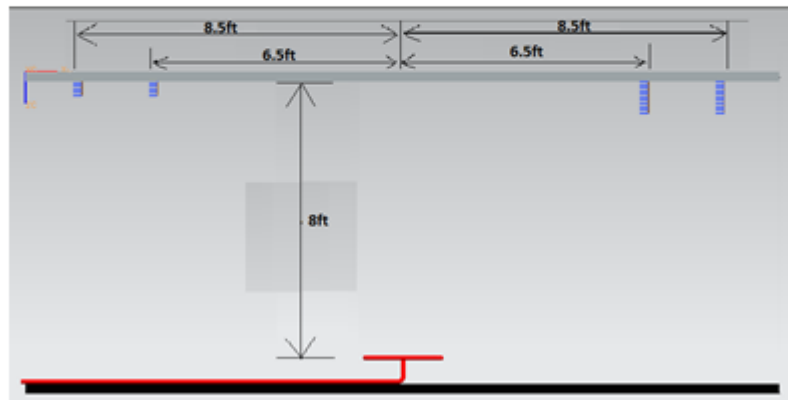

Company Confidential

tyco  
Fire Protection Products

14

## // Test 2 Configuration

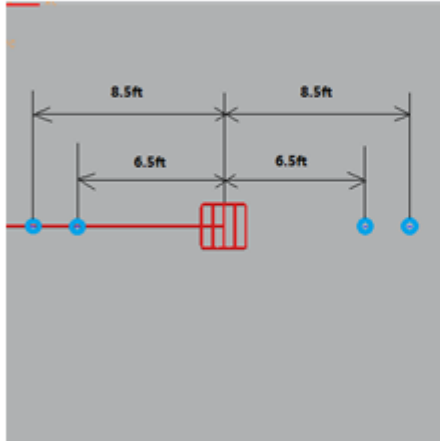

Company Confidential

**tyco**  
Fire Protection Products

15

## // Test 2 Configuration

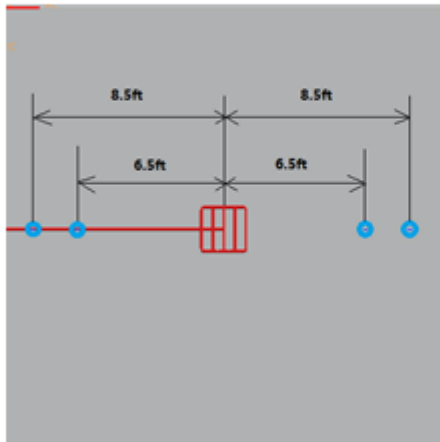

Company Confidential

**tyco**  
Fire Protection Products

15

## // Test 3 Configuration

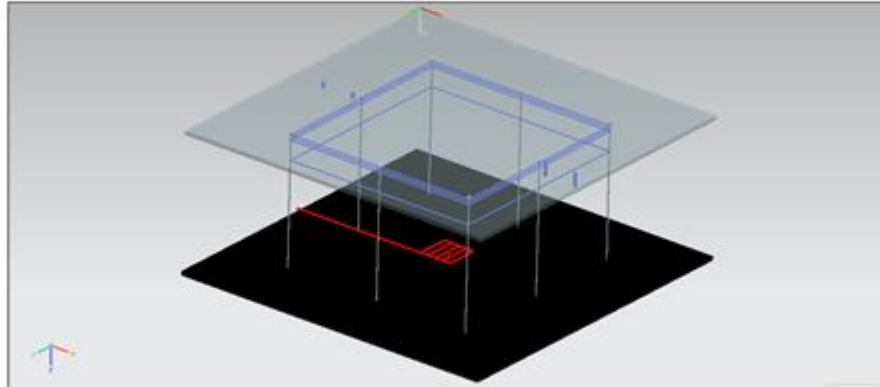

Company Confidential

tyco  
Fire Protection Products

17

## // Test 3 Configuration

// The thermocouple trees are the same with test 2 to do the repeatability test

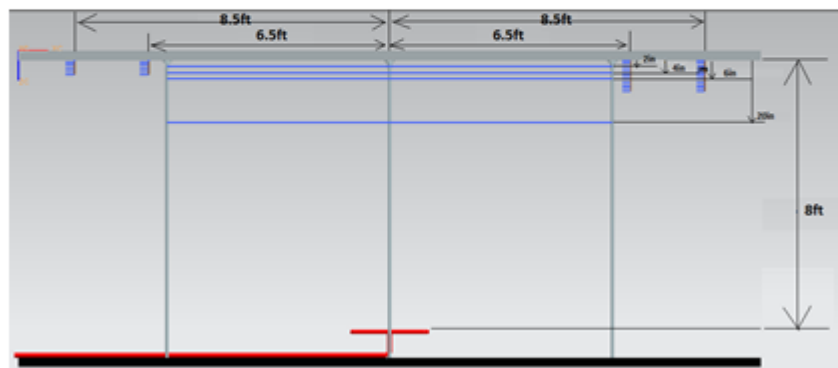

Company Confidential

tyco  
Fire Protection Products

18

## // Test 3 Configuration

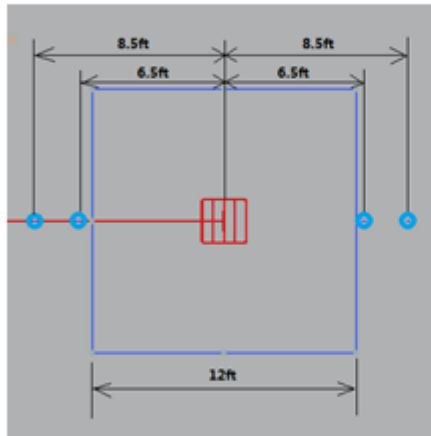

//The LHD box is  
3.66mx3.66m (12ft\*12ft).

Company Confidential

tyco  
Fire Protection Products

19

## // Test 3 Configuration

//There are four LHD loops along the ceiling and the distances from the ceiling:

- 5.08cm (2in), 10.16cm (4in), 15.24cm (6in) and 50.8cm (20in)

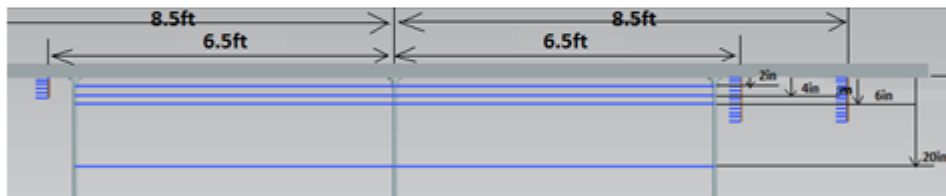

Company Confidential

tyco  
Fire Protection Products

20

## // Test 4 Configuration

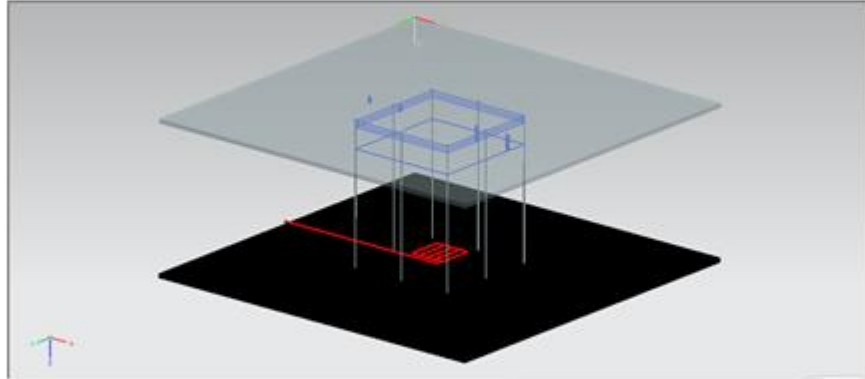

Company Confidential

**tyco**  
Fire Protection Products

21

## // Test 4 Configuration

// The thermocouple trees are the same with test 1 to do the repeatability test

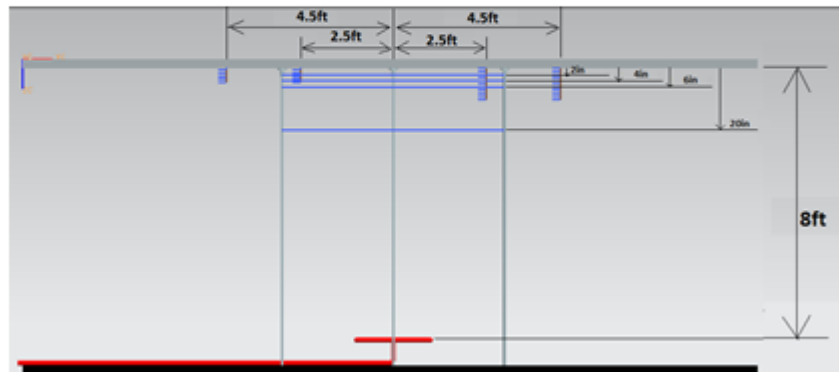

Company Confidential

**tyco**  
Fire Protection Products

22

## //Test 4 Configuration

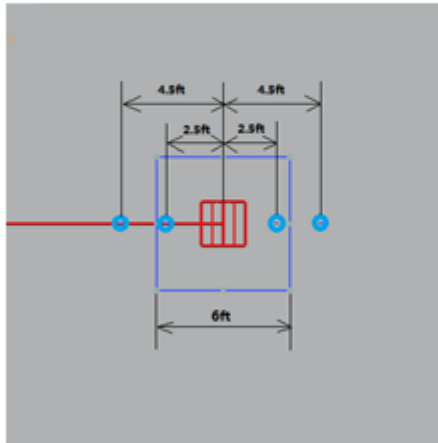

//The LHD box is  
1.83mx1.83m (6ft\*6ft)

Company Confidential

tyco  
Fire Protection Products

23

## //Test 4

//There are four LHD loops along the ceiling and the distances from the ceiling:

- 5.08cm (2in), 10.16cm (4in), 15.24cm (6in) and 50.8cm (20in)



Company Confidential

tyco  
Fire Protection Products

24



## // FDS Simulations

// Simulated ceiling heights

// Ceiling heights:

- 2.44m (8ft)
- 3.66m (12ft)
- 4.88m (16ft)
- 6.10m (20ft)
- 7.32m (24ft)
- 8.53m (28ft)
- 9.75m (32ft)
- 10.97m (36ft)
- 12.19m (40ft)

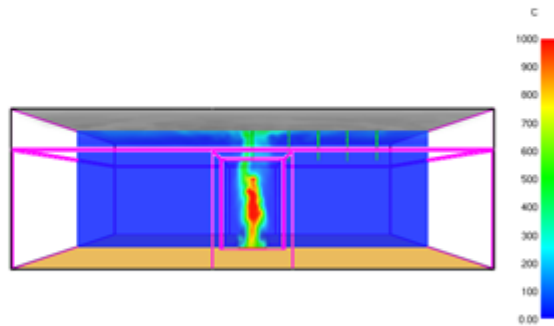

Company Confidential

tyco  
Fire Protection Products

25

## // Temperature Profiles for Test

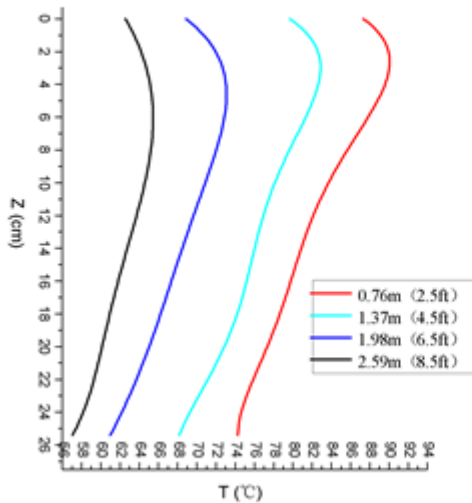

// With radiation balance compensation considered

Company Confidential

tyco  
Fire Protection Products

26

## // Repeatability

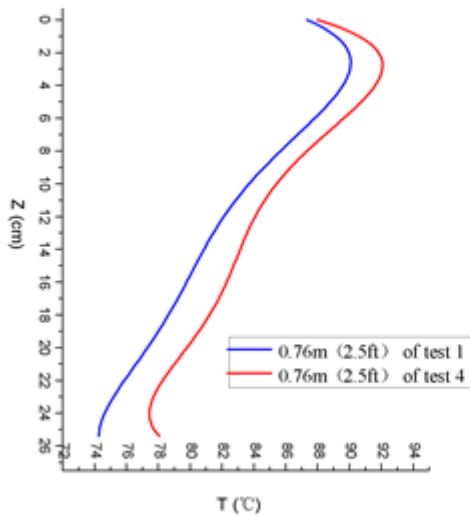

// Test 1 & Test 4  
// 0.76m (2.5ft)  
// All conditions are the same  
// The LHD is thin enough to be neglected  
// With 2.2°C error in thermocouple measurements considered

Company Confidential

tyco  
Fire Protection Products

27

## // Repeatability

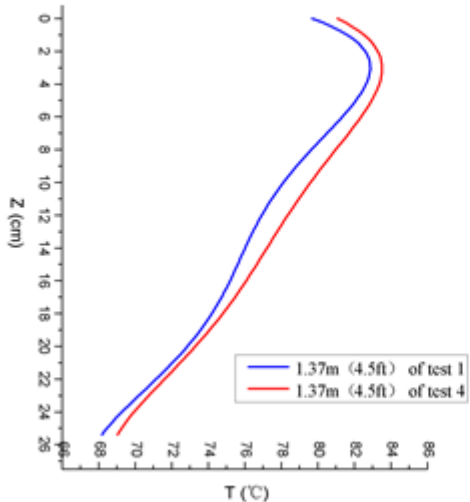

// Test 1 & Test 4  
// 1.37m (4.5ft)  
// All conditions are the same  
// The LHD is thin enough to be neglected  
// With 2.2°C error in thermocouple measurements considered

Company Confidential

tyco  
Fire Protection Products

28

## // Repeatability

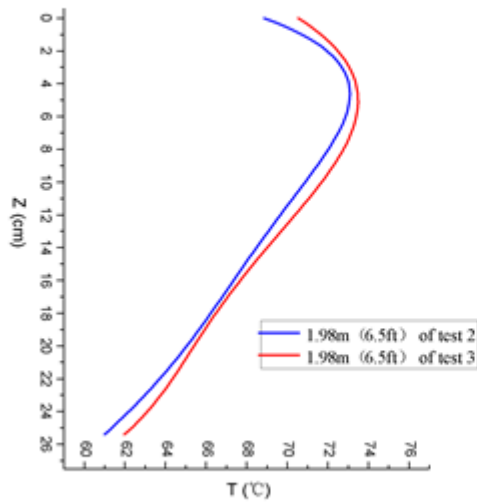

// Test 2 & Test 3  
// 1.98m (6.5ft)  
// All conditions are the same  
// The LHD is thin enough to be neglected  
// With 2.2°C error in thermocouple measurements considered

Company Confidential

tyco  
Fire Protection Products

29

## // Repeatability

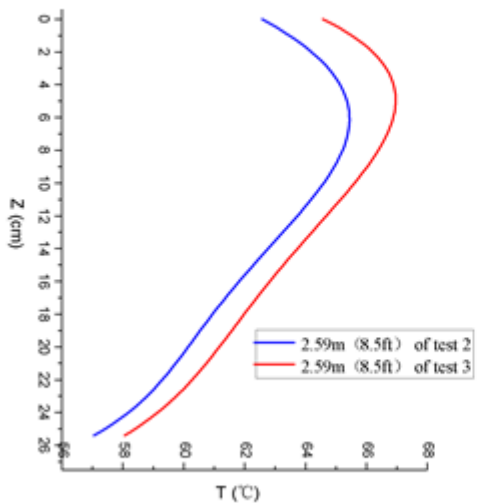

// Test 2 & Test 3  
// 2.59m (8.5ft)  
// All conditions are the same  
// The LHD is thin enough to be neglected  
// With 2.2°C error in thermocouple measurements considered

Company Confidential

tyco  
Fire Protection Products

30

## // Analysis of Repeatability

// Temperature profiles from both sets of tests are similar, supporting the repeatability factor of the tests

// On average, tests 3 & 4 are shifted about 0.5°C-1.5°C, this could be the result of:

- 2.2°C error present in the thermocouples
- Error in thermocouple spacing after relocation

// Due to the slight difference in temperature profiles, we can consider these tests as repeatable

Company Confidential

**tyco**  
Fire Protection Products

21

## // LHD response time

// Test 3

// LHD activation temperature: 68°C

LHD configuration	Position of LHD (distance to the ceiling)	Response time (s)	Average Steady State Temperature at 1.98m (6.5 feet) (°C)
3.66m*3.66m (12ft*12ft) box	5.08 cm (2 inches)	Not activated	75
	10.16cm (4 inches)	Not activated	71
	15.24cm (6 inches)	Not activated	68
	50.8 cm (20 inches)	Not activated	/

Company Confidential

**tyco**  
Fire Protection Products

22

## // LHD response time

// Test 4

// LHD activation temperature: 68°C

LHD configuration	Position of LHD (distance to the ceiling)	Response time (s)	Average Steady State Temperature at 0.762m (2.5 feet) (°C)
1.83m*1.83m(6ft*6ft) box	5.08 cm (2 inches)	104s	90
	10.16cm (4 inches)	139s	85
	15.24cm (6 inches)	361s	82
	50.8 cm (20 inches)	Not activated	/

Company Confidential

tyco  
Fire Protection Products

22

## // Boundary and Thermal Layer Thickness

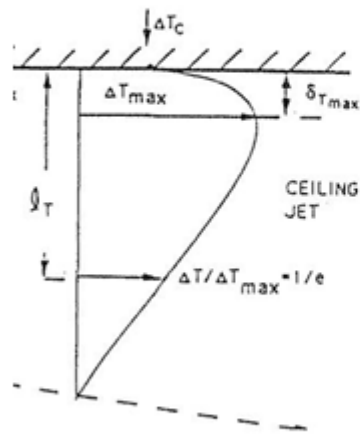

// Boundary layer is from the ceiling to the position where the greatest temperature is.

// Thermal thickness is the characteristic length of ceiling jet, where

$$\frac{\Delta T}{\Delta T_{max}} = \frac{1}{e}$$

Company Confidential

tyco  
Fire Protection Products

23

# // FDS Simulations

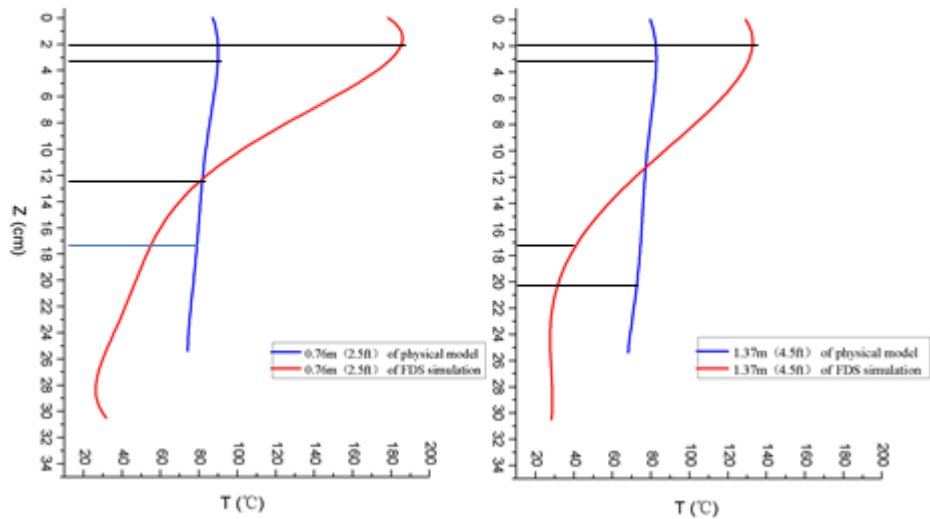

Company Confidential

**tyco**  
Fire Protection Products

25

# // FDS Simulations

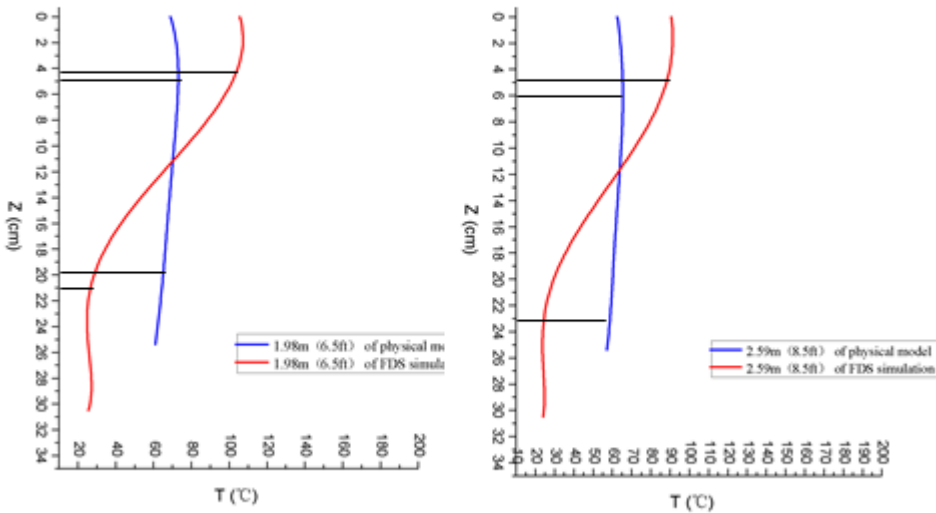

Company Confidential

**tyco**  
Fire Protection Products

26

## // FDS Simulations

//The simulation temperature is higher than the test values which is expected according to Motevalli's literature concerning ceiling jets and temperature profiles

//The boundary layer thickness and thermal thickness are close to the test and simulation values.

## // Validation

### //Hand Calculations

- Boundary Layer
- Thermal Thickness
- Highest temperature

### //Motevalli's Work

# // Boundary Layer Thickness

## // Boundary Layer Thickness

$$\delta_{T_{max}} = 0.0152(r)^{1.35} \text{ for } 0.26 \leq \frac{r}{H} \leq 2.0$$

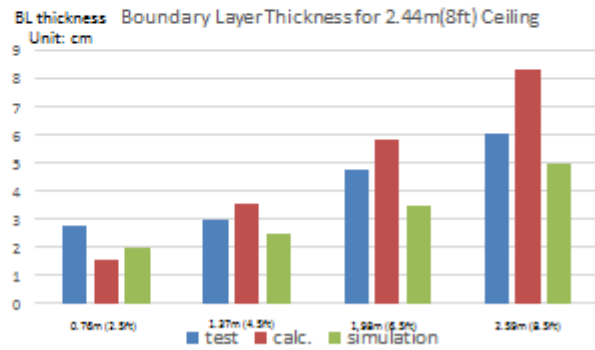
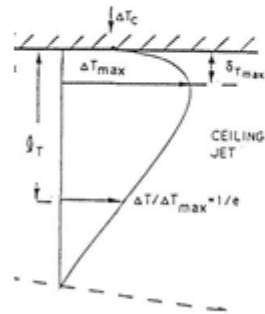

Company Confidential

tyco  
Fire Protection Products

28

# // Thermal Thickness

## // Thermal Thickness

$$\ell_{T/H} = 0.112 \left( 1 - \exp \left[ -2.24 \left( \frac{r}{H} \right) \right] \right) \text{ for } 0.26 \leq r/H \leq 2.0$$

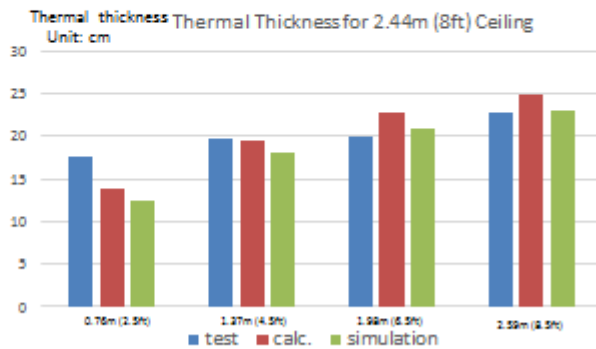
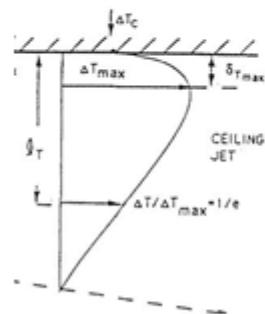

Company Confidential

tyco  
Fire Protection Products

40



## // Highest Temperature

// Highest Temperature

$$T - T_{\infty} = \frac{5.38(\dot{Q}/r)^{2/3}}{H} \text{ for } r/H \geq 0.18$$

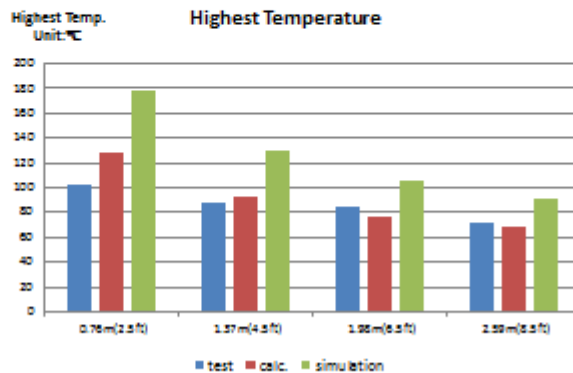

Company Confidential

tyco  
Fire Protection Products

41

## // FDS Validity

// FDS's validity can not be concluded for the boundary layer from our findings

- Simulated temperatures are greater than actual temperatures
- Boundary layer is sub-grid scale

// FDS is valid at radial distances  $\geq 1.38\text{m}$  (4.5ft) for the thermal layer

- Percent error  $< 10\%$

// According to Hurley and Munguia's FDS validations, as ceiling height increases, the accuracy of FDS temperature readings also increases

Company Confidential

tyco  
Fire Protection Products

42

## // Motevalli's Work

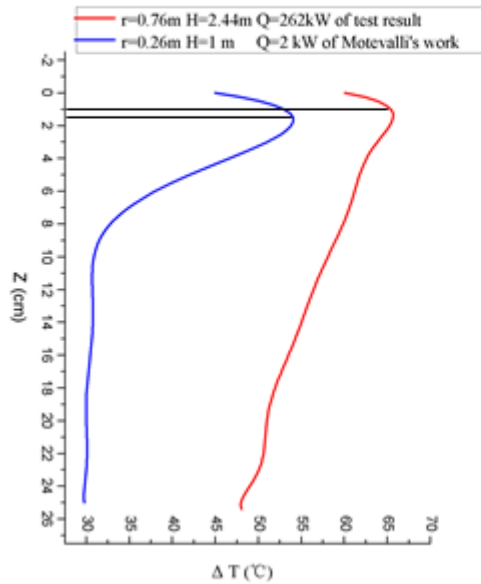

	Motevalli's Test	Our Test
H(m)	1	2.44
r(m)	0.26	0.76
$\dot{Q}$ (kW)	2	262
r/H(1)	0.26	0.3125
$\dot{Q}_0^*(1)$	0.0018	0.026

Atental

**tyco**  
Fire Protection Products

43

## // Scaling

// For our test, we used a 1.83m (6ft) box, where LHD was 0.92m (3ft) away from the fire center

Ceiling Height	LHD spacing
2.44m (8ft)	0.91m (3ft)
12.19m (40ft)	4.57m (15ft)

// However, the maximum LHD spacing is 3.05m (10ft)

Company Confidential

**tyco**  
Fire Protection Products

44

## // Thermal thickness

// According to calculation and simulation result, the thermal thickness for different ceiling heights are as follows:

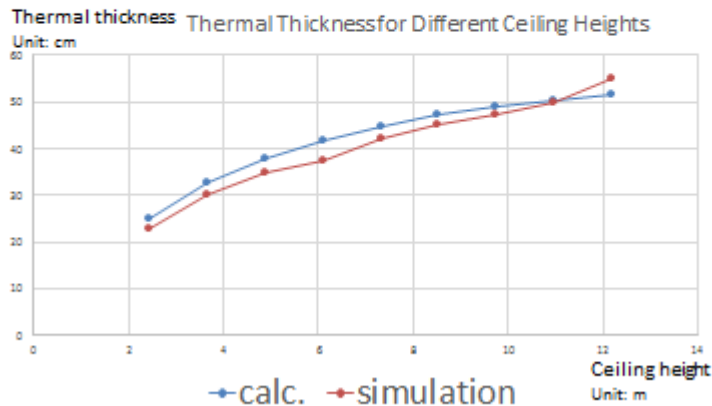

Company Confidential

tyco  
Fire Protection Products

45

## // Conclusion

// According to the tests we have completed, 0.508m (20") is not valid for all ceiling heights

// For ceiling heights less than 11m (36ft)

- 0.508m (20") is located outside the free jet
- Slow activation or no activation at all

// For ceiling heights greater than 11m (36ft), 0.508m (20") is an appropriate height.

- LHD can be installed a slightly lower than 0.508m (20") considering the free jet is greater than 0.508m (20")

Company Confidential

tyco  
Fire Protection Products

46

## // Future Work

// Test ceiling heights greater than 11m (36ft) to validate the calculation

// Research where the .508m (20in) NFPA 72 requirement came from

// Test the influence of the slope ceiling, beams and racks

---

Company Confidential

**tyco**  
Fire Protection Products

47

## // Acknowledgements

// Professor Nicholas Dembsey

// Melissa Avila

// Madhura Karve

// Joe Schindler

// Jake Dube

// Matt Miller

// Tyco Fire Protection Products

---

Company Confidential

**tyco**  
Fire Protection Products

48



# Questions?

## Appendix I: FDS Input Files

8 ft. ceiling:

&HEAD CHID='8ft2in/'

&TIME T\_END=300.00/ simulation time

&MESH ID='MESH1', IJK=24,24,36, XB=3.05,4.27,3.05,4.27,0.00,1.83/

&MESH ID='MESH2', IJK=144,144,12, XB=0.00,7.32,0.00,7.32,1.83,2.44/

&MESH ID='MESH3', IJK=10,24,6, XB=0.00,3.05,0.00,7.32,0.00,1.83/

&MESH ID='MESH6', IJK=10,24,6, XB=4.27,7.32,0.00,7.32,0.00,1.83/

&MESH ID='MESH4', IJK=4,10,6, XB=3.05,4.27,0.00,3.05,0.00,1.83/

&MESH ID='MESH5', IJK=4,10,6, XB=3.05,4.27,4.27,7.32,0.00,1.83/

&DEVC ID='THCPA01', QUANTITY='THERMOCOUPLE', XYZ=3.66,3.66,2.44/

&DEVC ID='THCPA02', QUANTITY='THERMOCOUPLE', XYZ=3.66,3.66,2.41/

&DEVC ID='THCPA03', QUANTITY='THERMOCOUPLE', XYZ=3.66,3.66,2.39/

&DEVC ID='THCPA04', QUANTITY='THERMOCOUPLE', XYZ=3.66,3.66,2.36/

&DEVC ID='THCPA05', QUANTITY='THERMOCOUPLE', XYZ=3.66,3.66,2.34/

&DEVC ID='THCPA06', QUANTITY='THERMOCOUPLE', XYZ=3.66,3.66,2.31/

&DEVC ID='THCPA07', QUANTITY='THERMOCOUPLE', XYZ=3.66,3.66,2.29/

&DEVC ID='THCPA08', QUANTITY='THERMOCOUPLE', XYZ=3.66,3.66,2.26/

&DEVC ID='THCPA09', QUANTITY='THERMOCOUPLE', XYZ=3.66,3.66,2.24/

&DEVC ID='THCPA10', QUANTITY='THERMOCOUPLE', XYZ=3.66,3.66,2.21/

&DEVC ID='THCPA11', QUANTITY='THERMOCOUPLE', XYZ=3.66,3.66,2.18/

&DEVC ID='THCPA12', QUANTITY='THERMOCOUPLE', XYZ=3.66,3.66,2.16/

&DEVC ID='THCPA13', QUANTITY='THERMOCOUPLE', XYZ=3.66,3.66,2.13/

&DEVC ID='THCPA14', QUANTITY='THERMOCOUPLE', XYZ=3.66,3.66,2.08/

&DEVC ID='THCPA15', QUANTITY='THERMOCOUPLE', XYZ=3.66,3.66,2.03/

&DEVC ID='THCPA16', QUANTITY='THERMOCOUPLE', XYZ=3.66,3.66,1.98/

&DEVC ID='THCPA17', QUANTITY='THERMOCOUPLE', XYZ=3.66,3.66,1.93/

&DEVC ID='THCPA18', QUANTITY='THERMOCOUPLE', XYZ=3.66,3.66,1.88/

&DEVC ID='THCPA19', QUANTITY='THERMOCOUPLE', XYZ=3.66,3.66,1.83/

&DEVC ID='THCPB01', QUANTITY='THERMOCOUPLE', XYZ=4.42,3.66,2.44/

&DEVC ID='THCPB02', QUANTITY='THERMOCOUPLE', XYZ=4.42,3.66,2.41/

&DEVC ID='THCPB03', QUANTITY='THERMOCOUPLE', XYZ=4.42,3.66,2.39/

&DEVC ID='THCPB04', QUANTITY='THERMOCOUPLE', XYZ=4.42,3.66,2.36/

&DEVC ID='THCPB05', QUANTITY='THERMOCOUPLE', XYZ=4.42,3.66,2.34/

&DEVC ID='THCPB06', QUANTITY='THERMOCOUPLE', XYZ=4.42,3.66,2.31/

&DEVC ID='THCPB07', QUANTITY='THERMOCOUPLE', XYZ=4.42,3.66,2.29/

&DEVC ID='THCPB08', QUANTITY='THERMOCOUPLE', XYZ=4.42,3.66,2.26/

&DEVC ID='THCPB09', QUANTITY='THERMOCOUPLE', XYZ=4.42,3.66,2.24/

&DEVC ID='THCPB10', QUANTITY='THERMOCOUPLE', XYZ=4.42,3.66,2.21/  
&DEVC ID='THCPB11', QUANTITY='THERMOCOUPLE', XYZ=4.42,3.66,2.18/  
&DEVC ID='THCPB12', QUANTITY='THERMOCOUPLE', XYZ=4.42,3.66,2.16/  
&DEVC ID='THCPB13', QUANTITY='THERMOCOUPLE', XYZ=4.42,3.66,2.13/  
&DEVC ID='THCPB14', QUANTITY='THERMOCOUPLE', XYZ=4.42,3.66,2.08/  
&DEVC ID='THCPB15', QUANTITY='THERMOCOUPLE', XYZ=4.42,3.66,2.03/  
&DEVC ID='THCPB16', QUANTITY='THERMOCOUPLE', XYZ=4.42,3.66,1.98/  
&DEVC ID='THCPB17', QUANTITY='THERMOCOUPLE', XYZ=4.42,3.66,1.93/  
&DEVC ID='THCPB18', QUANTITY='THERMOCOUPLE', XYZ=4.42,3.66,1.88/  
&DEVC ID='THCPB19', QUANTITY='THERMOCOUPLE', XYZ=4.42,3.66,1.83/  
&DEVC ID='THCPC01', QUANTITY='THERMOCOUPLE', XYZ=5.03,3.66,2.44/  
&DEVC ID='THCPC02', QUANTITY='THERMOCOUPLE', XYZ=5.03,3.66,2.41/  
&DEVC ID='THCPC03', QUANTITY='THERMOCOUPLE', XYZ=5.03,3.66,2.39/  
&DEVC ID='THCPC04', QUANTITY='THERMOCOUPLE', XYZ=5.03,3.66,2.36/  
&DEVC ID='THCPC05', QUANTITY='THERMOCOUPLE', XYZ=5.03,3.66,2.34/  
&DEVC ID='THCPC06', QUANTITY='THERMOCOUPLE', XYZ=5.03,3.66,2.31/  
&DEVC ID='THCPC07', QUANTITY='THERMOCOUPLE', XYZ=5.03,3.66,2.29/  
&DEVC ID='THCPC08', QUANTITY='THERMOCOUPLE', XYZ=5.03,3.66,2.26/  
&DEVC ID='THCPC09', QUANTITY='THERMOCOUPLE', XYZ=5.03,3.66,2.24/  
&DEVC ID='THCPC10', QUANTITY='THERMOCOUPLE', XYZ=5.03,3.66,2.21/  
&DEVC ID='THCPC11', QUANTITY='THERMOCOUPLE', XYZ=5.03,3.66,2.18/  
&DEVC ID='THCPC12', QUANTITY='THERMOCOUPLE', XYZ=5.03,3.66,2.16/  
&DEVC ID='THCPC13', QUANTITY='THERMOCOUPLE', XYZ=5.03,3.66,2.13/  
&DEVC ID='THCPC14', QUANTITY='THERMOCOUPLE', XYZ=5.03,3.66,2.08/  
&DEVC ID='THCPC15', QUANTITY='THERMOCOUPLE', XYZ=5.03,3.66,2.03/  
&DEVC ID='THCPC16', QUANTITY='THERMOCOUPLE', XYZ=5.03,3.66,1.98/  
&DEVC ID='THCPC17', QUANTITY='THERMOCOUPLE', XYZ=5.03,3.66,1.93/  
&DEVC ID='THCPC18', QUANTITY='THERMOCOUPLE', XYZ=5.03,3.66,1.88/  
&DEVC ID='THCPC19', QUANTITY='THERMOCOUPLE', XYZ=5.03,3.66,1.83/  
&DEVC ID='THCPD01', QUANTITY='THERMOCOUPLE', XYZ=5.64,3.66,2.44/  
&DEVC ID='THCPD02', QUANTITY='THERMOCOUPLE', XYZ=5.64,3.66,2.41/  
&DEVC ID='THCPD03', QUANTITY='THERMOCOUPLE', XYZ=5.64,3.66,2.39/  
&DEVC ID='THCPD04', QUANTITY='THERMOCOUPLE', XYZ=5.64,3.66,2.36/  
&DEVC ID='THCPD05', QUANTITY='THERMOCOUPLE', XYZ=5.64,3.66,2.34/  
&DEVC ID='THCPD06', QUANTITY='THERMOCOUPLE', XYZ=5.64,3.66,2.31/  
&DEVC ID='THCPD07', QUANTITY='THERMOCOUPLE', XYZ=5.64,3.66,2.29/  
&DEVC ID='THCPD08', QUANTITY='THERMOCOUPLE', XYZ=5.64,3.66,2.26/  
&DEVC ID='THCPD09', QUANTITY='THERMOCOUPLE', XYZ=5.64,3.66,2.24/  
&DEVC ID='THCPD10', QUANTITY='THERMOCOUPLE', XYZ=5.64,3.66,2.21/  
&DEVC ID='THCPD11', QUANTITY='THERMOCOUPLE', XYZ=5.64,3.66,2.18/

```

&DEVC ID='THCPD12', QUANTITY='THERMOCOUPLE', XYZ=5.64,3.66,2.16/
&DEVC ID='THCPD13', QUANTITY='THERMOCOUPLE', XYZ=5.64,3.66,2.13/
&DEVC ID='THCPD14', QUANTITY='THERMOCOUPLE', XYZ=5.64,3.66,2.08/
&DEVC ID='THCPD15', QUANTITY='THERMOCOUPLE', XYZ=5.64,3.66,2.03/
&DEVC ID='THCPD16', QUANTITY='THERMOCOUPLE', XYZ=5.64,3.66,1.98/
&DEVC ID='THCPD17', QUANTITY='THERMOCOUPLE', XYZ=5.64,3.66,1.93/
&DEVC ID='THCPD18', QUANTITY='THERMOCOUPLE', XYZ=5.64,3.66,1.88/
&DEVC ID='THCPD19', QUANTITY='THERMOCOUPLE', XYZ=5.64,3.66,1.83/
&DEVC ID='THCPE01', QUANTITY='THERMOCOUPLE', XYZ=6.25,3.66,2.44/
&DEVC ID='THCPE02', QUANTITY='THERMOCOUPLE', XYZ=6.25,3.66,2.41/
&DEVC ID='THCPE03', QUANTITY='THERMOCOUPLE', XYZ=6.25,3.66,2.39/
&DEVC ID='THCPE04', QUANTITY='THERMOCOUPLE', XYZ=6.25,3.66,2.36/
&DEVC ID='THCPE05', QUANTITY='THERMOCOUPLE', XYZ=6.25,3.66,2.34/
&DEVC ID='THCPE06', QUANTITY='THERMOCOUPLE', XYZ=6.25,3.66,2.31/
&DEVC ID='THCPE07', QUANTITY='THERMOCOUPLE', XYZ=6.25,3.66,2.29/
&DEVC ID='THCPE08', QUANTITY='THERMOCOUPLE', XYZ=6.25,3.66,2.26/
&DEVC ID='THCPE09', QUANTITY='THERMOCOUPLE', XYZ=6.25,3.66,2.24/
&DEVC ID='THCPE10', QUANTITY='THERMOCOUPLE', XYZ=6.25,3.66,2.21/
&DEVC ID='THCPE11', QUANTITY='THERMOCOUPLE', XYZ=6.25,3.66,2.18/
&DEVC ID='THCPE12', QUANTITY='THERMOCOUPLE', XYZ=6.25,3.66,2.16/
&DEVC ID='THCPE13', QUANTITY='THERMOCOUPLE', XYZ=6.25,3.66,2.13/
&DEVC ID='THCPE14', QUANTITY='THERMOCOUPLE', XYZ=6.25,3.66,2.08/
&DEVC ID='THCPE15', QUANTITY='THERMOCOUPLE', XYZ=6.25,3.66,2.03/
&DEVC ID='THCPE16', QUANTITY='THERMOCOUPLE', XYZ=6.25,3.66,1.98/
&DEVC ID='THCPE17', QUANTITY='THERMOCOUPLE', XYZ=6.25,3.66,1.93/
&DEVC ID='THCPE18', QUANTITY='THERMOCOUPLE', XYZ=6.25,3.66,1.88/
&DEVC ID='THCPE19', QUANTITY='THERMOCOUPLE', XYZ=6.25,3.66,1.83/
&SURF ID='BURNER',
  COLOR='RED',
  HRRPUA=725.00/
&SURF ID='ADIABATIC',
  COLOR='GRAY 80',
  ADIABATIC=.TRUE./

```

```

&VENT SURF_ID='BURNER', XB=3.35,3.96,3.35,3.96,0.00,0.00, COLOR='RED'/ BURNER
&VENT SURF_ID='OPEN', XB=3.05,3.05,3.05,4.27,0.00,1.83/ Vent
&VENT SURF_ID='OPEN', XB=4.27,4.27,3.05,4.27,0.00,1.83/ Vent
&VENT SURF_ID='OPEN', XB=3.05,4.27,3.05,3.05,0.00,1.83/ Vent
&VENT SURF_ID='OPEN', XB=3.05,4.27,4.27,4.27,0.00,1.83/ Vent
&VENT SURF_ID='OPEN', XB=0.00,7.32,0.00,7.32,1.83,1.83/ Vent

```



&VENT SURF\_ID='OPEN', XB=0.00,0.00,0.00,7.32,1.83,2.44/ Vent  
&VENT SURF\_ID='OPEN', XB=0.00,7.32,0.00,0.00,1.83,2.44/ Vent  
&VENT SURF\_ID='OPEN', XB=0.00,7.32,7.32,7.32,1.83,2.44/ Vent  
&VENT SURF\_ID='OPEN', XB=7.32,7.32,0.00,7.32,1.83,2.44/ Vent  
&VENT SURF\_ID='ADIABATIC', XB=0.00,7.32,0.00,7.32,2.44,2.44/ Vent  
&VENT SURF\_ID='OPEN', XB=0.00,7.32,0.00,0.00,0.00,1.83/ Vent  
&VENT SURF\_ID='OPEN', XB=7.32,7.32,0.00,7.32,0.00,1.83/ Vent  
&VENT SURF\_ID='OPEN', XB=0.00,0.00,0.00,7.32,0.00,1.83/ Vent  
&VENT SURF\_ID='OPEN', XB=0.00,7.32,7.32,7.32,0.00,1.83/ Vent

&SLCF QUANTITY='TEMPERATURE', PBX=3.66/  
&SLCF QUANTITY='TEMPERATURE', PBY=3.66/  
&SLCF QUANTITY='TEMPERATURE', PBZ=1.52/  
&SLCF QUANTITY='TEMPERATURE', PBZ=1.68/  
&SLCF QUANTITY='TEMPERATURE', PBZ=1.83/  
&SLCF QUANTITY='TEMPERATURE', PBZ=1.98/  
&SLCF QUANTITY='TEMPERATURE', PBZ=2.13/  
&SLCF QUANTITY='TEMPERATURE', PBZ=2.29/  
&SLCF QUANTITY='TEMPERATURE', PBZ=2.44/

&TAIL /

12 ft. ceiling:

&HEAD CHID='12ft2in'/

&TIME T\_END=300.00/

&MESH ID='MESH1', IJK=24,24,60, XB=3.05,4.27,3.05,4.27,0.00,3.05/  
&MESH ID='MESH2', IJK=144,144,12, XB=0.00,7.32,0.00,7.32,3.05,3.66/  
&MESH ID='MESH3', IJK=20,48,20, XB=0.00,3.05,0.00,7.32,0.00,3.05/  
&MESH ID='MESH6', IJK=20,48,20, XB=4.27,7.32,0.00,7.32,0.00,3.05/  
&MESH ID='MESH4', IJK=8,20,20, XB=3.05,4.27,0.00,3.05,0.00,3.05/  
&MESH ID='MESH5', IJK=8,20,20, XB=3.05,4.27,4.27,7.32,0.00,3.05/

&DEVC ID='THCPA01', QUANTITY='THERMOCOUPLE', XYZ=3.66,3.66,3.66/  
&DEVC ID='THCPA02', QUANTITY='THERMOCOUPLE', XYZ=3.66,3.66,3.63/  
&DEVC ID='THCPA03', QUANTITY='THERMOCOUPLE', XYZ=3.66,3.66,3.61/  
&DEVC ID='THCPA04', QUANTITY='THERMOCOUPLE', XYZ=3.66,3.66,3.58/  
&DEVC ID='THCPA05', QUANTITY='THERMOCOUPLE', XYZ=3.66,3.66,3.56/

&DEVC ID='THCPA06', QUANTITY='THERMOCOUPLE', XYZ=3.66,3.66,3.53/  
&DEVC ID='THCPA07', QUANTITY='THERMOCOUPLE', XYZ=3.66,3.66,3.51/  
&DEVC ID='THCPA08', QUANTITY='THERMOCOUPLE', XYZ=3.66,3.66,3.48/  
&DEVC ID='THCPA09', QUANTITY='THERMOCOUPLE', XYZ=3.66,3.66,3.45/  
&DEVC ID='THCPA10', QUANTITY='THERMOCOUPLE', XYZ=3.66,3.66,3.43/  
&DEVC ID='THCPA11', QUANTITY='THERMOCOUPLE', XYZ=3.66,3.66,3.40/  
&DEVC ID='THCPA12', QUANTITY='THERMOCOUPLE', XYZ=3.66,3.66,3.38/  
&DEVC ID='THCPA13', QUANTITY='THERMOCOUPLE', XYZ=3.66,3.66,3.35/  
&DEVC ID='THCPA14', QUANTITY='THERMOCOUPLE', XYZ=3.66,3.66,3.30/  
&DEVC ID='THCPA15', QUANTITY='THERMOCOUPLE', XYZ=3.66,3.66,3.25/  
&DEVC ID='THCPA16', QUANTITY='THERMOCOUPLE', XYZ=3.66,3.66,3.20/  
&DEVC ID='THCPA17', QUANTITY='THERMOCOUPLE', XYZ=3.66,3.66,3.15/  
&DEVC ID='THCPA18', QUANTITY='THERMOCOUPLE', XYZ=3.66,3.66,3.10/  
&DEVC ID='THCPA19', QUANTITY='THERMOCOUPLE', XYZ=3.66,3.66,3.05/  
&DEVC ID='THCPB01', QUANTITY='THERMOCOUPLE', XYZ=4.42,3.66,3.66/  
&DEVC ID='THCPB02', QUANTITY='THERMOCOUPLE', XYZ=4.42,3.66,3.63/  
&DEVC ID='THCPB03', QUANTITY='THERMOCOUPLE', XYZ=4.42,3.66,3.61/  
&DEVC ID='THCPB04', QUANTITY='THERMOCOUPLE', XYZ=4.42,3.66,3.58/  
&DEVC ID='THCPB05', QUANTITY='THERMOCOUPLE', XYZ=4.42,3.66,3.56/  
&DEVC ID='THCPB06', QUANTITY='THERMOCOUPLE', XYZ=4.42,3.66,3.53/  
&DEVC ID='THCPB07', QUANTITY='THERMOCOUPLE', XYZ=4.42,3.66,3.51/  
&DEVC ID='THCPB08', QUANTITY='THERMOCOUPLE', XYZ=4.42,3.66,3.48/  
&DEVC ID='THCPB09', QUANTITY='THERMOCOUPLE', XYZ=4.42,3.66,3.45/  
&DEVC ID='THCPB10', QUANTITY='THERMOCOUPLE', XYZ=4.42,3.66,3.43/  
&DEVC ID='THCPB11', QUANTITY='THERMOCOUPLE', XYZ=4.42,3.66,3.40/  
&DEVC ID='THCPB12', QUANTITY='THERMOCOUPLE', XYZ=4.42,3.66,3.38/  
&DEVC ID='THCPB13', QUANTITY='THERMOCOUPLE', XYZ=4.42,3.66,3.35/  
&DEVC ID='THCPB14', QUANTITY='THERMOCOUPLE', XYZ=4.42,3.66,3.30/  
&DEVC ID='THCPB15', QUANTITY='THERMOCOUPLE', XYZ=4.42,3.66,3.25/  
&DEVC ID='THCPB16', QUANTITY='THERMOCOUPLE', XYZ=4.42,3.66,3.20/  
&DEVC ID='THCPB17', QUANTITY='THERMOCOUPLE', XYZ=4.42,3.66,3.15/  
&DEVC ID='THCPB18', QUANTITY='THERMOCOUPLE', XYZ=4.42,3.66,3.10/  
&DEVC ID='THCPB19', QUANTITY='THERMOCOUPLE', XYZ=4.42,3.66,3.05/  
&DEVC ID='THCPC01', QUANTITY='THERMOCOUPLE', XYZ=5.03,3.66,3.66/  
&DEVC ID='THCPC02', QUANTITY='THERMOCOUPLE', XYZ=5.03,3.66,3.63/  
&DEVC ID='THCPC03', QUANTITY='THERMOCOUPLE', XYZ=5.03,3.66,3.61/  
&DEVC ID='THCPC04', QUANTITY='THERMOCOUPLE', XYZ=5.03,3.66,3.58/  
&DEVC ID='THCPC05', QUANTITY='THERMOCOUPLE', XYZ=5.03,3.66,3.56/  
&DEVC ID='THCPC06', QUANTITY='THERMOCOUPLE', XYZ=5.03,3.66,3.53/  
&DEVC ID='THCPC07', QUANTITY='THERMOCOUPLE', XYZ=5.03,3.66,3.51/

&DEVC ID='THCPC08', QUANTITY='THERMOCOUPLE', XYZ=5.03,3.66,3.48/  
&DEVC ID='THCPC09', QUANTITY='THERMOCOUPLE', XYZ=5.03,3.66,3.45/  
&DEVC ID='THCPC10', QUANTITY='THERMOCOUPLE', XYZ=5.03,3.66,3.43/  
&DEVC ID='THCPC11', QUANTITY='THERMOCOUPLE', XYZ=5.03,3.66,3.40/  
&DEVC ID='THCPC12', QUANTITY='THERMOCOUPLE', XYZ=5.03,3.66,3.38/  
&DEVC ID='THCPC13', QUANTITY='THERMOCOUPLE', XYZ=5.03,3.66,3.35/  
&DEVC ID='THCPC14', QUANTITY='THERMOCOUPLE', XYZ=5.03,3.66,3.30/  
&DEVC ID='THCPC15', QUANTITY='THERMOCOUPLE', XYZ=5.03,3.66,3.25/  
&DEVC ID='THCPC16', QUANTITY='THERMOCOUPLE', XYZ=5.03,3.66,3.20/  
&DEVC ID='THCPC17', QUANTITY='THERMOCOUPLE', XYZ=5.03,3.66,3.15/  
&DEVC ID='THCPC18', QUANTITY='THERMOCOUPLE', XYZ=5.03,3.66,3.10/  
&DEVC ID='THCPC19', QUANTITY='THERMOCOUPLE', XYZ=5.03,3.66,3.05/  
&DEVC ID='THCPD01', QUANTITY='THERMOCOUPLE', XYZ=5.64,3.66,3.66/  
&DEVC ID='THCPD02', QUANTITY='THERMOCOUPLE', XYZ=5.64,3.66,3.63/  
&DEVC ID='THCPD03', QUANTITY='THERMOCOUPLE', XYZ=5.64,3.66,3.61/  
&DEVC ID='THCPD04', QUANTITY='THERMOCOUPLE', XYZ=5.64,3.66,3.58/  
&DEVC ID='THCPD05', QUANTITY='THERMOCOUPLE', XYZ=5.64,3.66,3.56/  
&DEVC ID='THCPD06', QUANTITY='THERMOCOUPLE', XYZ=5.64,3.66,3.53/  
&DEVC ID='THCPD07', QUANTITY='THERMOCOUPLE', XYZ=5.64,3.66,3.51/  
&DEVC ID='THCPD08', QUANTITY='THERMOCOUPLE', XYZ=5.64,3.66,3.48/  
&DEVC ID='THCPD09', QUANTITY='THERMOCOUPLE', XYZ=5.64,3.66,3.45/  
&DEVC ID='THCPD10', QUANTITY='THERMOCOUPLE', XYZ=5.64,3.66,3.43/  
&DEVC ID='THCPD11', QUANTITY='THERMOCOUPLE', XYZ=5.64,3.66,3.40/  
&DEVC ID='THCPD12', QUANTITY='THERMOCOUPLE', XYZ=5.64,3.66,3.38/  
&DEVC ID='THCPD13', QUANTITY='THERMOCOUPLE', XYZ=5.64,3.66,3.35/  
&DEVC ID='THCPD14', QUANTITY='THERMOCOUPLE', XYZ=5.64,3.66,3.32/  
&DEVC ID='THCPD15', QUANTITY='THERMOCOUPLE', XYZ=5.64,3.66,3.25/  
&DEVC ID='THCPD16', QUANTITY='THERMOCOUPLE', XYZ=5.64,3.66,3.20/  
&DEVC ID='THCPD17', QUANTITY='THERMOCOUPLE', XYZ=5.64,3.66,3.15/  
&DEVC ID='THCPD18', QUANTITY='THERMOCOUPLE', XYZ=5.64,3.66,3.10/  
&DEVC ID='THCPD19', QUANTITY='THERMOCOUPLE', XYZ=5.64,3.66,3.05/  
&DEVC ID='THCPE01', QUANTITY='THERMOCOUPLE', XYZ=6.25,3.66,3.66/  
&DEVC ID='THCPE02', QUANTITY='THERMOCOUPLE', XYZ=6.25,3.66,3.63/  
&DEVC ID='THCPE03', QUANTITY='THERMOCOUPLE', XYZ=6.25,3.66,3.61/  
&DEVC ID='THCPE04', QUANTITY='THERMOCOUPLE', XYZ=6.25,3.66,3.58/  
&DEVC ID='THCPE05', QUANTITY='THERMOCOUPLE', XYZ=6.25,3.66,3.56/  
&DEVC ID='THCPE06', QUANTITY='THERMOCOUPLE', XYZ=6.25,3.66,3.53/  
&DEVC ID='THCPE07', QUANTITY='THERMOCOUPLE', XYZ=6.25,3.66,3.51/  
&DEVC ID='THCPE08', QUANTITY='THERMOCOUPLE', XYZ=6.25,3.66,3.48/  
&DEVC ID='THCPE09', QUANTITY='THERMOCOUPLE', XYZ=6.25,3.66,3.45/

&DEVC ID='THCPE10', QUANTITY='THERMOCOUPLE', XYZ=6.25,3.66,3.43/  
&DEVC ID='THCPE11', QUANTITY='THERMOCOUPLE', XYZ=6.25,3.66,3.40/  
&DEVC ID='THCPE12', QUANTITY='THERMOCOUPLE', XYZ=6.25,3.66,3.38/  
&DEVC ID='THCPE13', QUANTITY='THERMOCOUPLE', XYZ=6.25,3.66,3.35/  
&DEVC ID='THCPE14', QUANTITY='THERMOCOUPLE', XYZ=6.25,3.66,3.30/  
&DEVC ID='THCPE15', QUANTITY='THERMOCOUPLE', XYZ=6.25,3.66,3.25/  
&DEVC ID='THCPE16', QUANTITY='THERMOCOUPLE', XYZ=6.25,3.66,3.20/  
&DEVC ID='THCPE17', QUANTITY='THERMOCOUPLE', XYZ=6.25,3.66,3.15/  
&DEVC ID='THCPE18', QUANTITY='THERMOCOUPLE', XYZ=6.25,3.66,3.10/  
&DEVC ID='THCPE19', QUANTITY='THERMOCOUPLE', XYZ=6.25,3.66,3.05/  
&SURF ID='BURNER',  
    COLOR='RED',  
    HRRPUA=1.2974000E003/  
&SURF ID='ADIABATIC',  
    COLOR='GRAY 80',  
    ADIABATIC=.TRUE./

&VENT SURF\_ID='BURNER', XB=3.35,3.96,3.35,3.96,0.00,0.00, COLOR='RED'/ BURNER  
&VENT SURF\_ID='ADIABATIC', XB=0.00,7.32,0.00,7.32,3.66,3.66/ Vent  
&VENT SURF\_ID='OPEN', XB=0.00,0.00,0.00,7.32,0.00,3.66/ Vent  
&VENT SURF\_ID='OPEN', XB=7.32,7.32,0.00,7.32,0.00,3.66/ Vent  
&VENT SURF\_ID='OPEN', XB=0.00,7.32,0.00,0.00,0.00,3.66/ Vent  
&VENT SURF\_ID='OPEN', XB=0.00,7.32,7.32,7.32,0.00,3.66/ Vent  
&VENT SURF\_ID='OPEN', XB=3.05,3.05,0.00,7.32,0.00,3.05/ Vent  
&VENT SURF\_ID='OPEN', XB=4.27,4.27,0.00,7.32,0.00,3.05/ Vent  
&VENT SURF\_ID='OPEN', XB=3.05,4.27,3.05,3.05,0.00,3.05/ Vent  
&VENT SURF\_ID='OPEN', XB=3.05,4.27,4.27,4.27,0.00,3.05/ Vent  
&VENT SURF\_ID='OPEN', XB=0.00,7.32,0.00,7.32,3.05,3.05/ Vent

&SLCF QUANTITY='TEMPERATURE', PBX=3.66/  
&SLCF QUANTITY='TEMPERATURE', PBY=3.66/  
&SLCF QUANTITY='TEMPERATURE', PBZ=3.05/  
&SLCF QUANTITY='TEMPERATURE', PBZ=3.20/  
&SLCF QUANTITY='TEMPERATURE', PBZ=3.35/  
&SLCF QUANTITY='TEMPERATURE', PBZ=3.51/  
&SLCF QUANTITY='TEMPERATURE', PBZ=3.66/  
&SLCF QUANTITY='TEMPERATURE', PBZ=2.74/  
&SLCF QUANTITY='TEMPERATURE', PBZ=2.90/

&TAIL /

16 ft. ceiling:

&HEAD CHID='16ft2in'/

&TIME T\_END=300.00/

&MESH ID='MESH1', IJK=24,24,84, XB=3.05,4.27,3.05,4.27,0.00,4.27/

&MESH ID='MESH2', IJK=144,144,12, XB=0.00,7.32,0.00,7.32,4.27,4.88/

&MESH ID='MESH3', IJK=20,48,28, XB=0.00,3.05,0.00,7.32,0.00,4.27/

&MESH ID='MESH6', IJK=20,48,28, XB=4.27,7.32,0.00,7.32,0.00,4.27/

&MESH ID='MESH4', IJK=8,20,28, XB=3.05,4.27,0.00,3.05,0.00,4.27/

&MESH ID='MESH5', IJK=8,20,28, XB=3.05,4.27,4.27,7.32,0.00,4.27/

&DEVC ID='THCPA01', QUANTITY='THERMOCOUPLE', XYZ=3.66,3.66,4.88/

&DEVC ID='THCPA02', QUANTITY='THERMOCOUPLE', XYZ=3.66,3.66,4.85/

&DEVC ID='THCPA03', QUANTITY='THERMOCOUPLE', XYZ=3.66,3.66,4.83/

&DEVC ID='THCPA04', QUANTITY='THERMOCOUPLE', XYZ=3.66,3.66,4.80/

&DEVC ID='THCPA05', QUANTITY='THERMOCOUPLE', XYZ=3.66,3.66,4.78/

&DEVC ID='THCPA06', QUANTITY='THERMOCOUPLE', XYZ=3.66,3.66,4.75/

&DEVC ID='THCPA07', QUANTITY='THERMOCOUPLE', XYZ=3.66,3.66,4.72/

&DEVC ID='THCPA08', QUANTITY='THERMOCOUPLE', XYZ=3.66,3.66,4.70/

&DEVC ID='THCPA09', QUANTITY='THERMOCOUPLE', XYZ=3.66,3.66,4.67/

&DEVC ID='THCPA10', QUANTITY='THERMOCOUPLE', XYZ=3.66,3.66,4.65/

&DEVC ID='THCPA11', QUANTITY='THERMOCOUPLE', XYZ=3.66,3.66,4.62/

&DEVC ID='THCPA12', QUANTITY='THERMOCOUPLE', XYZ=3.66,3.66,4.60/

&DEVC ID='THCPA13', QUANTITY='THERMOCOUPLE', XYZ=3.66,3.66,4.57/

&DEVC ID='THCPA14', QUANTITY='THERMOCOUPLE', XYZ=3.66,3.66,4.52/

&DEVC ID='THCPA15', QUANTITY='THERMOCOUPLE', XYZ=3.66,3.66,4.47/

&DEVC ID='THCPA16', QUANTITY='THERMOCOUPLE', XYZ=3.66,3.66,4.42/

&DEVC ID='THCPA17', QUANTITY='THERMOCOUPLE', XYZ=3.66,3.66,4.37/

&DEVC ID='THCPA18', QUANTITY='THERMOCOUPLE', XYZ=3.66,3.66,4.32/

&DEVC ID='THCPA19', QUANTITY='THERMOCOUPLE', XYZ=3.66,3.66,4.27/

&DEVC ID='THCPB01', QUANTITY='THERMOCOUPLE', XYZ=4.42,3.66,4.88/

&DEVC ID='THCPB02', QUANTITY='THERMOCOUPLE', XYZ=4.42,3.66,4.85/

&DEVC ID='THCPB03', QUANTITY='THERMOCOUPLE', XYZ=4.42,3.66,4.83/

&DEVC ID='THCPB04', QUANTITY='THERMOCOUPLE', XYZ=4.42,3.66,4.80/

&DEVC ID='THCPB05', QUANTITY='THERMOCOUPLE', XYZ=4.42,3.66,4.78/

&DEVC ID='THCPB06', QUANTITY='THERMOCOUPLE', XYZ=4.42,3.66,4.75/

&DEVC ID='THCPB07', QUANTITY='THERMOCOUPLE', XYZ=4.42,3.66,4.72/

&DEVC ID='THCPB08', QUANTITY='THERMOCOUPLE', XYZ=4.42,3.66,4.70/

&DEVC ID='THCPB09', QUANTITY='THERMOCOUPLE', XYZ=4.42,3.66,4.67/  
&DEVC ID='THCPB10', QUANTITY='THERMOCOUPLE', XYZ=4.42,3.66,4.65/  
&DEVC ID='THCPB11', QUANTITY='THERMOCOUPLE', XYZ=4.42,3.66,4.62/  
&DEVC ID='THCPB12', QUANTITY='THERMOCOUPLE', XYZ=4.42,3.66,4.60/  
&DEVC ID='THCPB13', QUANTITY='THERMOCOUPLE', XYZ=4.42,3.66,4.57/  
&DEVC ID='THCPB14', QUANTITY='THERMOCOUPLE', XYZ=4.42,3.66,4.52/  
&DEVC ID='THCPB15', QUANTITY='THERMOCOUPLE', XYZ=4.42,3.66,4.47/  
&DEVC ID='THCPB16', QUANTITY='THERMOCOUPLE', XYZ=4.42,3.66,4.42/  
&DEVC ID='THCPB17', QUANTITY='THERMOCOUPLE', XYZ=4.42,3.66,4.37/  
&DEVC ID='THCPB18', QUANTITY='THERMOCOUPLE', XYZ=4.42,3.66,4.32/  
&DEVC ID='THCPB19', QUANTITY='THERMOCOUPLE', XYZ=4.42,3.66,4.27/  
&DEVC ID='THCPC01', QUANTITY='THERMOCOUPLE', XYZ=5.03,3.66,4.88/  
&DEVC ID='THCPC02', QUANTITY='THERMOCOUPLE', XYZ=5.03,3.66,4.85/  
&DEVC ID='THCPC03', QUANTITY='THERMOCOUPLE', XYZ=5.03,3.66,4.83/  
&DEVC ID='THCPC04', QUANTITY='THERMOCOUPLE', XYZ=5.03,3.66,4.80/  
&DEVC ID='THCPC05', QUANTITY='THERMOCOUPLE', XYZ=5.03,3.66,4.78/  
&DEVC ID='THCPC06', QUANTITY='THERMOCOUPLE', XYZ=5.03,3.66,4.75/  
&DEVC ID='THCPC07', QUANTITY='THERMOCOUPLE', XYZ=5.03,3.66,4.72/  
&DEVC ID='THCPC08', QUANTITY='THERMOCOUPLE', XYZ=5.03,3.66,4.70/  
&DEVC ID='THCPC09', QUANTITY='THERMOCOUPLE', XYZ=5.03,3.66,4.67/  
&DEVC ID='THCPC10', QUANTITY='THERMOCOUPLE', XYZ=5.03,3.66,4.65/  
&DEVC ID='THCPC11', QUANTITY='THERMOCOUPLE', XYZ=5.03,3.66,4.62/  
&DEVC ID='THCPC12', QUANTITY='THERMOCOUPLE', XYZ=5.03,3.66,4.60/  
&DEVC ID='THCPC13', QUANTITY='THERMOCOUPLE', XYZ=5.03,3.66,4.57/  
&DEVC ID='THCPC14', QUANTITY='THERMOCOUPLE', XYZ=5.03,3.66,4.52/  
&DEVC ID='THCPC15', QUANTITY='THERMOCOUPLE', XYZ=5.03,3.66,4.47/  
&DEVC ID='THCPC16', QUANTITY='THERMOCOUPLE', XYZ=5.03,3.66,4.42/  
&DEVC ID='THCPC17', QUANTITY='THERMOCOUPLE', XYZ=5.03,3.66,4.37/  
&DEVC ID='THCPC18', QUANTITY='THERMOCOUPLE', XYZ=5.03,3.66,4.32/  
&DEVC ID='THCPC19', QUANTITY='THERMOCOUPLE', XYZ=5.03,3.66,4.27/  
&DEVC ID='THCPD01', QUANTITY='THERMOCOUPLE', XYZ=5.64,3.66,4.88/  
&DEVC ID='THCPD02', QUANTITY='THERMOCOUPLE', XYZ=5.64,3.66,4.85/  
&DEVC ID='THCPD03', QUANTITY='THERMOCOUPLE', XYZ=5.64,3.66,4.83/  
&DEVC ID='THCPD04', QUANTITY='THERMOCOUPLE', XYZ=5.64,3.66,4.80/  
&DEVC ID='THCPD05', QUANTITY='THERMOCOUPLE', XYZ=5.64,3.66,4.78/  
&DEVC ID='THCPD06', QUANTITY='THERMOCOUPLE', XYZ=5.64,3.66,4.75/  
&DEVC ID='THCPD07', QUANTITY='THERMOCOUPLE', XYZ=5.64,3.66,4.72/  
&DEVC ID='THCPD08', QUANTITY='THERMOCOUPLE', XYZ=5.64,3.66,4.70/  
&DEVC ID='THCPD09', QUANTITY='THERMOCOUPLE', XYZ=5.64,3.66,4.67/  
&DEVC ID='THCPD10', QUANTITY='THERMOCOUPLE', XYZ=5.64,3.66,4.65/

```

&DEVC ID='THCPD11', QUANTITY='THERMOCOUPLE', XYZ=5.64,3.66,4.62/
&DEVC ID='THCPD12', QUANTITY='THERMOCOUPLE', XYZ=5.64,3.66,4.60/
&DEVC ID='THCPD13', QUANTITY='THERMOCOUPLE', XYZ=5.64,3.66,4.57/
&DEVC ID='THCPD14', QUANTITY='THERMOCOUPLE', XYZ=5.64,3.66,4.54/
&DEVC ID='THCPD15', QUANTITY='THERMOCOUPLE', XYZ=5.64,3.66,4.47/
&DEVC ID='THCPD16', QUANTITY='THERMOCOUPLE', XYZ=5.64,3.66,4.42/
&DEVC ID='THCPD17', QUANTITY='THERMOCOUPLE', XYZ=5.64,3.66,4.37/
&DEVC ID='THCPD18', QUANTITY='THERMOCOUPLE', XYZ=5.64,3.66,4.32/
&DEVC ID='THCPD19', QUANTITY='THERMOCOUPLE', XYZ=5.64,3.66,4.27/
&DEVC ID='THCPE01', QUANTITY='THERMOCOUPLE', XYZ=6.25,3.66,4.88/
&DEVC ID='THCPE02', QUANTITY='THERMOCOUPLE', XYZ=6.25,3.66,4.85/
&DEVC ID='THCPE03', QUANTITY='THERMOCOUPLE', XYZ=6.25,3.66,4.83/
&DEVC ID='THCPE04', QUANTITY='THERMOCOUPLE', XYZ=6.25,3.66,4.80/
&DEVC ID='THCPE05', QUANTITY='THERMOCOUPLE', XYZ=6.25,3.66,4.78/
&DEVC ID='THCPE06', QUANTITY='THERMOCOUPLE', XYZ=6.25,3.66,4.75/
&DEVC ID='THCPE07', QUANTITY='THERMOCOUPLE', XYZ=6.25,3.66,4.72/
&DEVC ID='THCPE08', QUANTITY='THERMOCOUPLE', XYZ=6.25,3.66,4.70/
&DEVC ID='THCPE09', QUANTITY='THERMOCOUPLE', XYZ=6.25,3.66,4.67/
&DEVC ID='THCPE10', QUANTITY='THERMOCOUPLE', XYZ=6.25,3.66,4.65/
&DEVC ID='THCPE11', QUANTITY='THERMOCOUPLE', XYZ=6.25,3.66,4.62/
&DEVC ID='THCPE12', QUANTITY='THERMOCOUPLE', XYZ=6.25,3.66,4.60/
&DEVC ID='THCPE13', QUANTITY='THERMOCOUPLE', XYZ=6.25,3.66,4.57/
&DEVC ID='THCPE14', QUANTITY='THERMOCOUPLE', XYZ=6.25,3.66,4.52/
&DEVC ID='THCPE15', QUANTITY='THERMOCOUPLE', XYZ=6.25,3.66,4.47/
&DEVC ID='THCPE16', QUANTITY='THERMOCOUPLE', XYZ=6.25,3.66,4.42/
&DEVC ID='THCPE17', QUANTITY='THERMOCOUPLE', XYZ=6.25,3.66,4.37/
&DEVC ID='THCPE18', QUANTITY='THERMOCOUPLE', XYZ=6.25,3.66,4.32/
&DEVC ID='THCPE19', QUANTITY='THERMOCOUPLE', XYZ=6.25,3.66,4.27/
&SURF ID='BURNER',
  COLOR='RED',
  HRRPUA=1.9974900E003/
&SURF ID='ADIABATIC',
  COLOR='GRAY 80',
  ADIABATIC=.TRUE./

```

```

&VENT SURF_ID='BURNER', XB=3.35,3.96,3.35,3.96,0.00,0.00, COLOR='RED'/ BURNER
&VENT SURF_ID='ADIABATIC', XB=0.00,7.32,0.00,7.32,4.88,4.88/ Vent
&VENT SURF_ID='OPEN', XB=0.00,0.00,0.00,7.32,0.00,4.88/ Vent
&VENT SURF_ID='OPEN', XB=7.32,7.32,0.00,7.32,0.00,4.88/ Vent
&VENT SURF_ID='OPEN', XB=0.00,7.32,0.00,0.00,0.00,4.88/ Vent

```

&VENT SURF\_ID='OPEN', XB=0.00,7.32,7.32,7.32,0.00,4.88/ Vent  
&VENT SURF\_ID='OPEN', XB=3.05,3.05,0.00,7.32,0.00,4.27/ Vent  
&VENT SURF\_ID='OPEN', XB=4.27,4.27,0.00,7.32,0.00,4.27/ Vent  
&VENT SURF\_ID='OPEN', XB=3.05,4.27,3.05,3.05,0.00,4.27/ Vent  
&VENT SURF\_ID='OPEN', XB=3.05,4.27,4.27,4.27,0.00,4.27/ Vent  
&VENT SURF\_ID='OPEN', XB=0.00,7.32,0.00,7.32,4.27,4.27/ Vent

&SLCF QUANTITY='TEMPERATURE', PBX=3.66/  
&SLCF QUANTITY='TEMPERATURE', PBY=3.66/  
&SLCF QUANTITY='TEMPERATURE', PBZ=4.12/  
&SLCF QUANTITY='TEMPERATURE', PBZ=4.26/  
&SLCF QUANTITY='TEMPERATURE', PBZ=4.27/  
&SLCF QUANTITY='TEMPERATURE', PBZ=4.42/  
&SLCF QUANTITY='TEMPERATURE', PBZ=4.73/  
&SLCF QUANTITY='TEMPERATURE', PBZ=4.87/  
&SLCF QUANTITY='TEMPERATURE', PBZ=4.88/

&TAIL /

20 ft. ceiling:

&HEAD CHID='20ft2in'/

&TIME T\_END=300.00/

&MESH ID='MESH1A', IJK=24,24,54, XB=3.05,4.27,3.05,4.27,0.00,2.74, MPI\_PROCESS=0/

&MESH ID='MESH3', IJK=20,48,18, XB=0.00,3.05,0.00,7.32,0.00,2.74, MPI\_PROCESS=0 /

&MESH ID='MESH1B', IJK=24,24,54, XB=3.05,4.27,3.05,4.27,2.74,5.49, MPI\_PROCESS=1/

&MESH ID='MESH4', IJK=8,20,18, XB=3.05,4.27,0.00,3.05,0.00,2.74, MPI\_PROCESS=1

/

&MESH ID='MESH2A', IJK=48,72,12, XB=0.00,2.44,0.00,3.66,5.49,6.10, MPI\_PROCESS=2/

&MESH ID='MESH5', IJK=8,20,18, XB=3.05,4.27,4.27,7.32,0.00,2.74, MPI\_PROCESS=2

/

&MESH ID='MESH2B', IJK=48,72,12, XB=0.00,2.44,3.66,7.32,5.49,6.10, MPI\_PROCESS=3/

&MESH ID='MESH6', IJK=20,48,18, XB=4.27,7.32,0.00,7.32,0.00,2.74, MPI\_PROCESS=3

/

&MESH ID='MESH2C', IJK=48,72,12, XB=2.44,4.88,0.00,3.66,5.49,6.10, MPI\_PROCESS=4/

&MESH ID='MESH3A', IJK=20,48,18, XB=0.00,3.05,0.00,7.32,2.74,5.49, MPI\_PROCESS=4/

&MESH ID='MESH2D', IJK=48,72,12, XB=2.44,4.88,3.66,7.32,5.49,6.10, MPI\_PROCESS=5/

&MESH ID='MESH4A', IJK=8,20,18, XB=3.05,4.27,0.00,3.05,2.74,5.49, MPI\_PROCESS=5

/



&MESH ID='MESH2E', IJK=48,72,12, XB=4.88,7.32,0.00,3.66,5.49,6.10, MPI\_PROCESS=6/  
&MESH ID='MESH5A', IJK=8,20,18, XB=3.05,4.27,4.27,7.32,2.74,5.49, MPI\_PROCESS=6  
/  
&MESH ID='MESH2F', IJK=48,72,12, XB=4.88,7.32,3.66,7.32,5.49,6.10, MPI\_PROCESS=7/  
&MESH ID='MESH6A', IJK=20,48,18, XB=4.27,7.32,0.00,7.32,2.74,5.49, MPI\_PROCESS=7/

&DEVC ID='THCPA01', QUANTITY='THERMOCOUPLE', XYZ=3.66,3.66,6.10/  
&DEVC ID='THCPA02', QUANTITY='THERMOCOUPLE', XYZ=3.66,3.66,6.07/  
&DEVC ID='THCPA03', QUANTITY='THERMOCOUPLE', XYZ=3.66,3.66,6.05/  
&DEVC ID='THCPA04', QUANTITY='THERMOCOUPLE', XYZ=3.66,3.66,6.02/  
&DEVC ID='THCPA05', QUANTITY='THERMOCOUPLE', XYZ=3.66,3.66,5.99/  
&DEVC ID='THCPA06', QUANTITY='THERMOCOUPLE', XYZ=3.66,3.66,5.97/  
&DEVC ID='THCPA07', QUANTITY='THERMOCOUPLE', XYZ=3.66,3.66,5.94/  
&DEVC ID='THCPA08', QUANTITY='THERMOCOUPLE', XYZ=3.66,3.66,5.92/  
&DEVC ID='THCPA09', QUANTITY='THERMOCOUPLE', XYZ=3.66,3.66,5.89/  
&DEVC ID='THCPA10', QUANTITY='THERMOCOUPLE', XYZ=3.66,3.66,5.87/  
&DEVC ID='THCPA11', QUANTITY='THERMOCOUPLE', XYZ=3.66,3.66,5.84/  
&DEVC ID='THCPA12', QUANTITY='THERMOCOUPLE', XYZ=3.66,3.66,5.82/  
&DEVC ID='THCPA13', QUANTITY='THERMOCOUPLE', XYZ=3.66,3.66,5.79/  
&DEVC ID='THCPA14', QUANTITY='THERMOCOUPLE', XYZ=3.66,3.66,5.74/  
&DEVC ID='THCPA15', QUANTITY='THERMOCOUPLE', XYZ=3.66,3.66,5.69/  
&DEVC ID='THCPA16', QUANTITY='THERMOCOUPLE', XYZ=3.66,3.66,5.64/  
&DEVC ID='THCPA17', QUANTITY='THERMOCOUPLE', XYZ=3.66,3.66,5.59/  
&DEVC ID='THCPA18', QUANTITY='THERMOCOUPLE', XYZ=3.66,3.66,5.54/  
&DEVC ID='THCPA19', QUANTITY='THERMOCOUPLE', XYZ=3.66,3.66,5.49/  
&DEVC ID='THCPB01', QUANTITY='THERMOCOUPLE', XYZ=4.42,3.66,6.10/  
&DEVC ID='THCPB02', QUANTITY='THERMOCOUPLE', XYZ=4.42,3.66,6.07/  
&DEVC ID='THCPB03', QUANTITY='THERMOCOUPLE', XYZ=4.42,3.66,6.05/  
&DEVC ID='THCPB04', QUANTITY='THERMOCOUPLE', XYZ=4.42,3.66,6.02/  
&DEVC ID='THCPB05', QUANTITY='THERMOCOUPLE', XYZ=4.42,3.66,5.99/  
&DEVC ID='THCPB06', QUANTITY='THERMOCOUPLE', XYZ=4.42,3.66,5.97/  
&DEVC ID='THCPB07', QUANTITY='THERMOCOUPLE', XYZ=4.42,3.66,5.94/  
&DEVC ID='THCPB08', QUANTITY='THERMOCOUPLE', XYZ=4.42,3.66,5.92/  
&DEVC ID='THCPB09', QUANTITY='THERMOCOUPLE', XYZ=4.42,3.66,5.89/  
&DEVC ID='THCPB10', QUANTITY='THERMOCOUPLE', XYZ=4.42,3.66,5.87/  
&DEVC ID='THCPB11', QUANTITY='THERMOCOUPLE', XYZ=4.42,3.66,5.84/  
&DEVC ID='THCPB12', QUANTITY='THERMOCOUPLE', XYZ=4.42,3.66,5.82/  
&DEVC ID='THCPB13', QUANTITY='THERMOCOUPLE', XYZ=4.42,3.66,5.79/  
&DEVC ID='THCPB14', QUANTITY='THERMOCOUPLE', XYZ=4.42,3.66,5.74/  
&DEVC ID='THCPB15', QUANTITY='THERMOCOUPLE', XYZ=4.42,3.66,5.69/

&DEVC ID='THCPB16', QUANTITY='THERMOCOUPLE', XYZ=4.42,3.66,5.64/  
&DEVC ID='THCPB17', QUANTITY='THERMOCOUPLE', XYZ=4.42,3.66,5.59/  
&DEVC ID='THCPB18', QUANTITY='THERMOCOUPLE', XYZ=4.42,3.66,5.54/  
&DEVC ID='THCPB19', QUANTITY='THERMOCOUPLE', XYZ=4.42,3.66,5.49/  
&DEVC ID='THCPC01', QUANTITY='THERMOCOUPLE', XYZ=5.03,3.66,6.10/  
&DEVC ID='THCPC02', QUANTITY='THERMOCOUPLE', XYZ=5.03,3.66,6.07/  
&DEVC ID='THCPC03', QUANTITY='THERMOCOUPLE', XYZ=5.03,3.66,6.05/  
&DEVC ID='THCPC04', QUANTITY='THERMOCOUPLE', XYZ=5.03,3.66,6.02/  
&DEVC ID='THCPC05', QUANTITY='THERMOCOUPLE', XYZ=5.03,3.66,5.99/  
&DEVC ID='THCPC06', QUANTITY='THERMOCOUPLE', XYZ=5.03,3.66,5.97/  
&DEVC ID='THCPC07', QUANTITY='THERMOCOUPLE', XYZ=5.03,3.66,5.94/  
&DEVC ID='THCPC08', QUANTITY='THERMOCOUPLE', XYZ=5.03,3.66,5.92/  
&DEVC ID='THCPC09', QUANTITY='THERMOCOUPLE', XYZ=5.03,3.66,5.89/  
&DEVC ID='THCPC10', QUANTITY='THERMOCOUPLE', XYZ=5.03,3.66,5.87/  
&DEVC ID='THCPC11', QUANTITY='THERMOCOUPLE', XYZ=5.03,3.66,5.84/  
&DEVC ID='THCPC12', QUANTITY='THERMOCOUPLE', XYZ=5.03,3.66,5.82/  
&DEVC ID='THCPC13', QUANTITY='THERMOCOUPLE', XYZ=5.03,3.66,5.79/  
&DEVC ID='THCPC14', QUANTITY='THERMOCOUPLE', XYZ=5.03,3.66,5.74/  
&DEVC ID='THCPC15', QUANTITY='THERMOCOUPLE', XYZ=5.03,3.66,5.69/  
&DEVC ID='THCPC16', QUANTITY='THERMOCOUPLE', XYZ=5.03,3.66,5.64/  
&DEVC ID='THCPC17', QUANTITY='THERMOCOUPLE', XYZ=5.03,3.66,5.59/  
&DEVC ID='THCPC18', QUANTITY='THERMOCOUPLE', XYZ=5.03,3.66,5.54/  
&DEVC ID='THCPC19', QUANTITY='THERMOCOUPLE', XYZ=5.03,3.66,5.49/  
&DEVC ID='THCPD01', QUANTITY='THERMOCOUPLE', XYZ=5.64,3.66,6.10/  
&DEVC ID='THCPD02', QUANTITY='THERMOCOUPLE', XYZ=5.64,3.66,6.07/  
&DEVC ID='THCPD03', QUANTITY='THERMOCOUPLE', XYZ=5.64,3.66,6.05/  
&DEVC ID='THCPD04', QUANTITY='THERMOCOUPLE', XYZ=5.64,3.66,6.02/  
&DEVC ID='THCPD05', QUANTITY='THERMOCOUPLE', XYZ=5.64,3.66,5.99/  
&DEVC ID='THCPD06', QUANTITY='THERMOCOUPLE', XYZ=5.64,3.66,5.97/  
&DEVC ID='THCPD07', QUANTITY='THERMOCOUPLE', XYZ=5.64,3.66,5.94/  
&DEVC ID='THCPD08', QUANTITY='THERMOCOUPLE', XYZ=5.64,3.66,5.92/  
&DEVC ID='THCPD09', QUANTITY='THERMOCOUPLE', XYZ=5.64,3.66,5.89/  
&DEVC ID='THCPD10', QUANTITY='THERMOCOUPLE', XYZ=5.64,3.66,5.87/  
&DEVC ID='THCPD11', QUANTITY='THERMOCOUPLE', XYZ=5.64,3.66,5.84/  
&DEVC ID='THCPD12', QUANTITY='THERMOCOUPLE', XYZ=5.64,3.66,5.82/  
&DEVC ID='THCPD13', QUANTITY='THERMOCOUPLE', XYZ=5.64,3.66,5.79/  
&DEVC ID='THCPD14', QUANTITY='THERMOCOUPLE', XYZ=5.64,3.66,5.76/  
&DEVC ID='THCPD15', QUANTITY='THERMOCOUPLE', XYZ=5.64,3.66,5.69/  
&DEVC ID='THCPD16', QUANTITY='THERMOCOUPLE', XYZ=5.64,3.66,5.64/  
&DEVC ID='THCPD17', QUANTITY='THERMOCOUPLE', XYZ=5.64,3.66,5.59/

```

&DEVC ID='THCPD18', QUANTITY='THERMOCOUPLE', XYZ=5.64,3.66,5.54/
&DEVC ID='THCPD19', QUANTITY='THERMOCOUPLE', XYZ=5.64,3.66,5.49/
&DEVC ID='THCPE01', QUANTITY='THERMOCOUPLE', XYZ=6.25,3.66,6.10/
&DEVC ID='THCPE02', QUANTITY='THERMOCOUPLE', XYZ=6.25,3.66,6.07/
&DEVC ID='THCPE03', QUANTITY='THERMOCOUPLE', XYZ=6.25,3.66,6.05/
&DEVC ID='THCPE04', QUANTITY='THERMOCOUPLE', XYZ=6.25,3.66,6.02/
&DEVC ID='THCPE05', QUANTITY='THERMOCOUPLE', XYZ=6.25,3.66,5.99/
&DEVC ID='THCPE06', QUANTITY='THERMOCOUPLE', XYZ=6.25,3.66,5.97/
&DEVC ID='THCPE07', QUANTITY='THERMOCOUPLE', XYZ=6.25,3.66,5.94/
&DEVC ID='THCPE08', QUANTITY='THERMOCOUPLE', XYZ=6.25,3.66,5.92/
&DEVC ID='THCPE09', QUANTITY='THERMOCOUPLE', XYZ=6.25,3.66,5.89/
&DEVC ID='THCPE10', QUANTITY='THERMOCOUPLE', XYZ=6.25,3.66,5.87/
&DEVC ID='THCPE11', QUANTITY='THERMOCOUPLE', XYZ=6.25,3.66,5.84/
&DEVC ID='THCPE12', QUANTITY='THERMOCOUPLE', XYZ=6.25,3.66,5.82/
&DEVC ID='THCPE13', QUANTITY='THERMOCOUPLE', XYZ=6.25,3.66,5.79/
&DEVC ID='THCPE14', QUANTITY='THERMOCOUPLE', XYZ=6.25,3.66,5.74/
&DEVC ID='THCPE15', QUANTITY='THERMOCOUPLE', XYZ=6.25,3.66,5.69/
&DEVC ID='THCPE16', QUANTITY='THERMOCOUPLE', XYZ=6.25,3.66,5.64/
&DEVC ID='THCPE17', QUANTITY='THERMOCOUPLE', XYZ=6.25,3.66,5.59/
&DEVC ID='THCPE18', QUANTITY='THERMOCOUPLE', XYZ=6.25,3.66,5.54/
&DEVC ID='THCPE19', QUANTITY='THERMOCOUPLE', XYZ=6.25,3.66,5.49/
&SURF ID='BURNER',
  COLOR='RED',
  HRRPUA=986.97/
&SURF ID='ADIABATIC',
  COLOR='GRAY 80',
  ADIABATIC=.TRUE./

```

```

&VENT SURF_ID='BURNER', XB=3.35,3.96,3.35,3.96,0.00,0.00, COLOR='RED'/ BURNER
&VENT SURF_ID='ADIABATIC', XB=0.00,7.32,0.00,7.32,6.10,6.10/ Vent
&VENT SURF_ID='OPEN', XB=0.00,0.00,0.00,7.32,0.00,6.10/ Vent
&VENT SURF_ID='OPEN', XB=7.32,7.32,0.00,7.32,0.00,6.10/ Vent
&VENT SURF_ID='OPEN', XB=0.00,7.32,0.00,0.00,0.00,6.10/ Vent
&VENT SURF_ID='OPEN', XB=0.00,7.32,7.32,7.32,0.00,6.10/ Vent
&VENT SURF_ID='OPEN', XB=3.05,3.05,0.00,7.32,0.00,5.49/ Vent
&VENT SURF_ID='OPEN', XB=4.27,4.27,0.00,7.32,0.00,5.49/ Vent
&VENT SURF_ID='OPEN', XB=3.05,4.27,3.05,3.05,0.00,5.49/ Vent
&VENT SURF_ID='OPEN', XB=3.05,4.27,4.27,4.27,0.00,5.49/ Vent
&VENT SURF_ID='OPEN', XB=0.00,7.32,0.00,7.32,5.49,5.49/ Vent

```

&SLCF QUANTITY='TEMPERATURE', PBX=3.66/  
&SLCF QUANTITY='TEMPERATURE', PBY=3.66/  
&SLCF QUANTITY='TEMPERATURE', PBZ=5.18/  
&SLCF QUANTITY='TEMPERATURE', PBZ=5.33/  
&SLCF QUANTITY='TEMPERATURE', PBZ=5.49/  
&SLCF QUANTITY='TEMPERATURE', PBZ=5.64/  
&SLCF QUANTITY='TEMPERATURE', PBZ=5.79/  
&SLCF QUANTITY='TEMPERATURE', PBZ=5.94/  
&SLCF QUANTITY='TEMPERATURE', PBZ=6.10/

&TAIL /

24 ft. ceiling:

&HEAD CHID='24ft2in'/  
&TIME T\_END=300.00/

&MESH ID='MESH1', IJK=24,24,132, XB=3.05,4.27,3.05,4.27,0.00,6.71/  
&MESH ID='MESH2', IJK=144,144,12, XB=0.00,7.32,0.00,7.32,6.71,7.32/  
&MESH ID='MESH3', IJK=20,48,44, XB=0.00,3.05,0.00,7.32,0.00,6.71/  
&MESH ID='MESH6', IJK=20,48,44, XB=4.27,7.32,0.00,7.32,0.00,6.71/  
&MESH ID='MESH4', IJK=8,20,44, XB=3.05,4.27,0.00,3.05,0.00,6.71/  
&MESH ID='MESH5', IJK=8,20,44, XB=3.05,4.27,4.27,7.32,0.00,6.71/

&DEVC ID='THCPA01', QUANTITY='THERMOCOUPLE', XYZ=3.66,3.66,7.32/  
&DEVC ID='THCPA02', QUANTITY='THERMOCOUPLE', XYZ=3.66,3.66,7.29/  
&DEVC ID='THCPA03', QUANTITY='THERMOCOUPLE', XYZ=3.66,3.66,7.26/  
&DEVC ID='THCPA04', QUANTITY='THERMOCOUPLE', XYZ=3.66,3.66,7.24/  
&DEVC ID='THCPA05', QUANTITY='THERMOCOUPLE', XYZ=3.66,3.66,7.21/  
&DEVC ID='THCPA06', QUANTITY='THERMOCOUPLE', XYZ=3.66,3.66,7.19/  
&DEVC ID='THCPA07', QUANTITY='THERMOCOUPLE', XYZ=3.66,3.66,7.16/  
&DEVC ID='THCPA08', QUANTITY='THERMOCOUPLE', XYZ=3.66,3.66,7.14/  
&DEVC ID='THCPA09', QUANTITY='THERMOCOUPLE', XYZ=3.66,3.66,7.11/  
&DEVC ID='THCPA10', QUANTITY='THERMOCOUPLE', XYZ=3.66,3.66,7.09/  
&DEVC ID='THCPA11', QUANTITY='THERMOCOUPLE', XYZ=3.66,3.66,7.06/  
&DEVC ID='THCPA12', QUANTITY='THERMOCOUPLE', XYZ=3.66,3.66,7.04/  
&DEVC ID='THCPA13', QUANTITY='THERMOCOUPLE', XYZ=3.66,3.66,7.01/  
&DEVC ID='THCPA14', QUANTITY='THERMOCOUPLE', XYZ=3.66,3.66,6.96/  
&DEVC ID='THCPA15', QUANTITY='THERMOCOUPLE', XYZ=3.66,3.66,6.91/  
&DEVC ID='THCPA16', QUANTITY='THERMOCOUPLE', XYZ=3.66,3.66,6.86/

&DEVC ID='THCPA17', QUANTITY='THERMOCOUPLE', XYZ=3.66,3.66,6.81/  
&DEVC ID='THCPA18', QUANTITY='THERMOCOUPLE', XYZ=3.66,3.66,6.76/  
&DEVC ID='THCPA19', QUANTITY='THERMOCOUPLE', XYZ=3.66,3.66,6.71/  
&DEVC ID='THCPB01', QUANTITY='THERMOCOUPLE', XYZ=4.42,3.66,7.32/  
&DEVC ID='THCPB02', QUANTITY='THERMOCOUPLE', XYZ=4.42,3.66,7.29/  
&DEVC ID='THCPB03', QUANTITY='THERMOCOUPLE', XYZ=4.42,3.66,7.26/  
&DEVC ID='THCPB04', QUANTITY='THERMOCOUPLE', XYZ=4.42,3.66,7.24/  
&DEVC ID='THCPB05', QUANTITY='THERMOCOUPLE', XYZ=4.42,3.66,7.21/  
&DEVC ID='THCPB06', QUANTITY='THERMOCOUPLE', XYZ=4.42,3.66,7.19/  
&DEVC ID='THCPB07', QUANTITY='THERMOCOUPLE', XYZ=4.42,3.66,7.16/  
&DEVC ID='THCPB08', QUANTITY='THERMOCOUPLE', XYZ=4.42,3.66,7.14/  
&DEVC ID='THCPB09', QUANTITY='THERMOCOUPLE', XYZ=4.42,3.66,7.11/  
&DEVC ID='THCPB10', QUANTITY='THERMOCOUPLE', XYZ=4.42,3.66,7.09/  
&DEVC ID='THCPB11', QUANTITY='THERMOCOUPLE', XYZ=4.42,3.66,7.06/  
&DEVC ID='THCPB12', QUANTITY='THERMOCOUPLE', XYZ=4.42,3.66,7.04/  
&DEVC ID='THCPB13', QUANTITY='THERMOCOUPLE', XYZ=4.42,3.66,7.01/  
&DEVC ID='THCPB14', QUANTITY='THERMOCOUPLE', XYZ=4.42,3.66,6.96/  
&DEVC ID='THCPB15', QUANTITY='THERMOCOUPLE', XYZ=4.42,3.66,6.91/  
&DEVC ID='THCPB16', QUANTITY='THERMOCOUPLE', XYZ=4.42,3.66,6.86/  
&DEVC ID='THCPB17', QUANTITY='THERMOCOUPLE', XYZ=4.42,3.66,6.81/  
&DEVC ID='THCPB18', QUANTITY='THERMOCOUPLE', XYZ=4.42,3.66,6.76/  
&DEVC ID='THCPB19', QUANTITY='THERMOCOUPLE', XYZ=4.42,3.66,6.71/  
&DEVC ID='THCPC01', QUANTITY='THERMOCOUPLE', XYZ=5.03,3.66,7.32/  
&DEVC ID='THCPC02', QUANTITY='THERMOCOUPLE', XYZ=5.03,3.66,7.29/  
&DEVC ID='THCPC03', QUANTITY='THERMOCOUPLE', XYZ=5.03,3.66,7.26/  
&DEVC ID='THCPC04', QUANTITY='THERMOCOUPLE', XYZ=5.03,3.66,7.24/  
&DEVC ID='THCPC05', QUANTITY='THERMOCOUPLE', XYZ=5.03,3.66,7.21/  
&DEVC ID='THCPC06', QUANTITY='THERMOCOUPLE', XYZ=5.03,3.66,7.19/  
&DEVC ID='THCPC07', QUANTITY='THERMOCOUPLE', XYZ=5.03,3.66,7.16/  
&DEVC ID='THCPC08', QUANTITY='THERMOCOUPLE', XYZ=5.03,3.66,7.14/  
&DEVC ID='THCPC09', QUANTITY='THERMOCOUPLE', XYZ=5.03,3.66,7.11/  
&DEVC ID='THCPC10', QUANTITY='THERMOCOUPLE', XYZ=5.03,3.66,7.09/  
&DEVC ID='THCPC11', QUANTITY='THERMOCOUPLE', XYZ=5.03,3.66,7.06/  
&DEVC ID='THCPC12', QUANTITY='THERMOCOUPLE', XYZ=5.03,3.66,7.04/  
&DEVC ID='THCPC13', QUANTITY='THERMOCOUPLE', XYZ=5.03,3.66,7.01/  
&DEVC ID='THCPC14', QUANTITY='THERMOCOUPLE', XYZ=5.03,3.66,6.96/  
&DEVC ID='THCPC15', QUANTITY='THERMOCOUPLE', XYZ=5.03,3.66,6.91/  
&DEVC ID='THCPC16', QUANTITY='THERMOCOUPLE', XYZ=5.03,3.66,6.86/  
&DEVC ID='THCPC17', QUANTITY='THERMOCOUPLE', XYZ=5.03,3.66,6.81/  
&DEVC ID='THCPC18', QUANTITY='THERMOCOUPLE', XYZ=5.03,3.66,6.76/

&DEVC ID='THCPC19', QUANTITY='THERMOCOUPLE', XYZ=5.03,3.66,6.71/  
&DEVC ID='THCPD01', QUANTITY='THERMOCOUPLE', XYZ=5.64,3.66,7.32/  
&DEVC ID='THCPD02', QUANTITY='THERMOCOUPLE', XYZ=5.64,3.66,7.29/  
&DEVC ID='THCPD03', QUANTITY='THERMOCOUPLE', XYZ=5.64,3.66,7.26/  
&DEVC ID='THCPD04', QUANTITY='THERMOCOUPLE', XYZ=5.64,3.66,7.24/  
&DEVC ID='THCPD05', QUANTITY='THERMOCOUPLE', XYZ=5.64,3.66,7.21/  
&DEVC ID='THCPD06', QUANTITY='THERMOCOUPLE', XYZ=5.64,3.66,7.19/  
&DEVC ID='THCPD07', QUANTITY='THERMOCOUPLE', XYZ=5.64,3.66,7.16/  
&DEVC ID='THCPD08', QUANTITY='THERMOCOUPLE', XYZ=5.64,3.66,7.14/  
&DEVC ID='THCPD09', QUANTITY='THERMOCOUPLE', XYZ=5.64,3.66,7.11/  
&DEVC ID='THCPD10', QUANTITY='THERMOCOUPLE', XYZ=5.64,3.66,7.09/  
&DEVC ID='THCPD11', QUANTITY='THERMOCOUPLE', XYZ=5.64,3.66,7.06/  
&DEVC ID='THCPD12', QUANTITY='THERMOCOUPLE', XYZ=5.64,3.66,7.04/  
&DEVC ID='THCPD13', QUANTITY='THERMOCOUPLE', XYZ=5.64,3.66,7.01/  
&DEVC ID='THCPD14', QUANTITY='THERMOCOUPLE', XYZ=5.64,3.66,6.97/  
&DEVC ID='THCPD15', QUANTITY='THERMOCOUPLE', XYZ=5.64,3.66,6.91/  
&DEVC ID='THCPD16', QUANTITY='THERMOCOUPLE', XYZ=5.64,3.66,6.86/  
&DEVC ID='THCPD17', QUANTITY='THERMOCOUPLE', XYZ=5.64,3.66,6.81/  
&DEVC ID='THCPD18', QUANTITY='THERMOCOUPLE', XYZ=5.64,3.66,6.76/  
&DEVC ID='THCPD19', QUANTITY='THERMOCOUPLE', XYZ=5.64,3.66,6.71/  
&DEVC ID='THCPE01', QUANTITY='THERMOCOUPLE', XYZ=6.25,3.66,7.32/  
&DEVC ID='THCPE02', QUANTITY='THERMOCOUPLE', XYZ=6.25,3.66,7.29/  
&DEVC ID='THCPE03', QUANTITY='THERMOCOUPLE', XYZ=6.25,3.66,7.26/  
&DEVC ID='THCPE04', QUANTITY='THERMOCOUPLE', XYZ=6.25,3.66,7.24/  
&DEVC ID='THCPE05', QUANTITY='THERMOCOUPLE', XYZ=6.25,3.66,7.21/  
&DEVC ID='THCPE06', QUANTITY='THERMOCOUPLE', XYZ=6.25,3.66,7.19/  
&DEVC ID='THCPE07', QUANTITY='THERMOCOUPLE', XYZ=6.25,3.66,7.16/  
&DEVC ID='THCPE08', QUANTITY='THERMOCOUPLE', XYZ=6.25,3.66,7.14/  
&DEVC ID='THCPE09', QUANTITY='THERMOCOUPLE', XYZ=6.25,3.66,7.11/  
&DEVC ID='THCPE10', QUANTITY='THERMOCOUPLE', XYZ=6.25,3.66,7.09/  
&DEVC ID='THCPE11', QUANTITY='THERMOCOUPLE', XYZ=6.25,3.66,7.06/  
&DEVC ID='THCPE12', QUANTITY='THERMOCOUPLE', XYZ=6.25,3.66,7.04/  
&DEVC ID='THCPE13', QUANTITY='THERMOCOUPLE', XYZ=6.25,3.66,7.01/  
&DEVC ID='THCPE14', QUANTITY='THERMOCOUPLE', XYZ=6.25,3.66,6.96/  
&DEVC ID='THCPE15', QUANTITY='THERMOCOUPLE', XYZ=6.25,3.66,6.91/  
&DEVC ID='THCPE16', QUANTITY='THERMOCOUPLE', XYZ=6.25,3.66,6.86/  
&DEVC ID='THCPE17', QUANTITY='THERMOCOUPLE', XYZ=6.25,3.66,6.81/  
&DEVC ID='THCPE18', QUANTITY='THERMOCOUPLE', XYZ=6.25,3.66,6.76/  
&DEVC ID='THCPE19', QUANTITY='THERMOCOUPLE', XYZ=6.25,3.66,6.71/  
&SURF ID='BURNER',

COLOR='RED',  
HRRPUA=3.6696100E003/  
&SURF ID='ADIABATIC',  
COLOR='GRAY 80',  
ADIABATIC=.TRUE./

&VENT SURF\_ID='BURNER', XB=3.35,3.96,3.35,3.96,0.00,0.00, COLOR='RED'/ BURNER  
&VENT SURF\_ID='ADIABATIC', XB=0.00,7.32,0.00,7.32,7.32,7.32/ Vent  
&VENT SURF\_ID='OPEN', XB=0.00,0.00,0.00,7.32,0.00,7.32/ Vent  
&VENT SURF\_ID='OPEN', XB=7.32,7.32,0.00,7.32,0.00,7.32/ Vent  
&VENT SURF\_ID='OPEN', XB=0.00,7.32,0.00,0.00,0.00,7.32/ Vent  
&VENT SURF\_ID='OPEN', XB=0.00,7.32,7.32,7.32,0.00,7.32/ Vent  
&VENT SURF\_ID='OPEN', XB=3.05,3.05,0.00,7.32,0.00,6.71/ Vent  
&VENT SURF\_ID='OPEN', XB=4.27,4.27,0.00,7.32,0.00,6.71/ Vent  
&VENT SURF\_ID='OPEN', XB=3.05,4.27,3.05,3.05,0.00,6.71/ Vent  
&VENT SURF\_ID='OPEN', XB=3.05,4.27,4.27,4.27,0.00,6.71/ Vent  
&VENT SURF\_ID='OPEN', XB=0.00,7.32,0.00,7.32,6.71,6.71/ Vent

&SLCF QUANTITY='TEMPERATURE', PBX=3.66/  
&SLCF QUANTITY='TEMPERATURE', PBY=3.66/  
&SLCF QUANTITY='TEMPERATURE', PBZ=4.12/  
&SLCF QUANTITY='TEMPERATURE', PBZ=4.26/  
&SLCF QUANTITY='TEMPERATURE', PBZ=4.27/  
&SLCF QUANTITY='TEMPERATURE', PBZ=4.42/  
&SLCF QUANTITY='TEMPERATURE', PBZ=4.73/  
&SLCF QUANTITY='TEMPERATURE', PBZ=4.87/  
&SLCF QUANTITY='TEMPERATURE', PBZ=4.88/

&TAIL /

28 ft. ceiling:

&HEAD CHID='28ft2in'/  
&TIME T\_END=300.00/

&MESH ID='MESH1', IJK=24,24,144, XB=3.05,4.27,3.05,4.27,0.00,7.32/  
&MESH ID='MESH2', IJK=144,144,24, XB=0.00,7.32,0.00,7.32,7.32,8.53/  
&MESH ID='MESH3', IJK=20,48,48, XB=0.00,3.05,0.00,7.32,0.00,7.32/  
&MESH ID='MESH6', IJK=20,48,48, XB=4.27,7.32,0.00,7.32,0.00,7.32/  
&MESH ID='MESH4', IJK=8,20,48, XB=3.05,4.27,0.00,3.05,0.00,7.32/

&MESH ID='MESH5', IJK=8,20,48, XB=3.05,4.27,4.27,7.32,0.00,7.32/

&DEVC ID='THCPA01', QUANTITY='THERMOCOUPLE', XYZ=3.66,3.66,8.53/  
&DEVC ID='THCPA02', QUANTITY='THERMOCOUPLE', XYZ=3.66,3.66,8.51/  
&DEVC ID='THCPA03', QUANTITY='THERMOCOUPLE', XYZ=3.66,3.66,8.48/  
&DEVC ID='THCPA04', QUANTITY='THERMOCOUPLE', XYZ=3.66,3.66,8.46/  
&DEVC ID='THCPA05', QUANTITY='THERMOCOUPLE', XYZ=3.66,3.66,8.43/  
&DEVC ID='THCPA06', QUANTITY='THERMOCOUPLE', XYZ=3.66,3.66,8.41/  
&DEVC ID='THCPA07', QUANTITY='THERMOCOUPLE', XYZ=3.66,3.66,8.38/  
&DEVC ID='THCPA08', QUANTITY='THERMOCOUPLE', XYZ=3.66,3.66,8.36/  
&DEVC ID='THCPA09', QUANTITY='THERMOCOUPLE', XYZ=3.66,3.66,8.33/  
&DEVC ID='THCPA10', QUANTITY='THERMOCOUPLE', XYZ=3.66,3.66,8.31/  
&DEVC ID='THCPA11', QUANTITY='THERMOCOUPLE', XYZ=3.66,3.66,8.28/  
&DEVC ID='THCPA12', QUANTITY='THERMOCOUPLE', XYZ=3.66,3.66,8.25/  
&DEVC ID='THCPA13', QUANTITY='THERMOCOUPLE', XYZ=3.66,3.66,8.23/  
&DEVC ID='THCPA14', QUANTITY='THERMOCOUPLE', XYZ=3.66,3.66,8.18/  
&DEVC ID='THCPA15', QUANTITY='THERMOCOUPLE', XYZ=3.66,3.66,8.13/  
&DEVC ID='THCPA16', QUANTITY='THERMOCOUPLE', XYZ=3.66,3.66,8.08/  
&DEVC ID='THCPA17', QUANTITY='THERMOCOUPLE', XYZ=3.66,3.66,8.03/  
&DEVC ID='THCPA18', QUANTITY='THERMOCOUPLE', XYZ=3.66,3.66,7.98/  
&DEVC ID='THCPA19', QUANTITY='THERMOCOUPLE', XYZ=3.66,3.66,7.92/  
&DEVC ID='THCPB01', QUANTITY='THERMOCOUPLE', XYZ=4.42,3.66,8.53/  
&DEVC ID='THCPB02', QUANTITY='THERMOCOUPLE', XYZ=4.42,3.66,8.51/  
&DEVC ID='THCPB03', QUANTITY='THERMOCOUPLE', XYZ=4.42,3.66,8.48/  
&DEVC ID='THCPB04', QUANTITY='THERMOCOUPLE', XYZ=4.42,3.66,8.46/  
&DEVC ID='THCPB05', QUANTITY='THERMOCOUPLE', XYZ=4.42,3.66,8.43/  
&DEVC ID='THCPB06', QUANTITY='THERMOCOUPLE', XYZ=4.42,3.66,8.41/  
&DEVC ID='THCPB07', QUANTITY='THERMOCOUPLE', XYZ=4.42,3.66,8.38/  
&DEVC ID='THCPB08', QUANTITY='THERMOCOUPLE', XYZ=4.42,3.66,8.36/  
&DEVC ID='THCPB09', QUANTITY='THERMOCOUPLE', XYZ=4.42,3.66,8.33/  
&DEVC ID='THCPB10', QUANTITY='THERMOCOUPLE', XYZ=4.42,3.66,8.31/  
&DEVC ID='THCPB11', QUANTITY='THERMOCOUPLE', XYZ=4.42,3.66,8.28/  
&DEVC ID='THCPB12', QUANTITY='THERMOCOUPLE', XYZ=4.42,3.66,8.25/  
&DEVC ID='THCPB13', QUANTITY='THERMOCOUPLE', XYZ=4.42,3.66,8.23/  
&DEVC ID='THCPB14', QUANTITY='THERMOCOUPLE', XYZ=4.42,3.66,8.18/  
&DEVC ID='THCPB15', QUANTITY='THERMOCOUPLE', XYZ=4.42,3.66,8.13/  
&DEVC ID='THCPB16', QUANTITY='THERMOCOUPLE', XYZ=4.42,3.66,8.08/  
&DEVC ID='THCPB17', QUANTITY='THERMOCOUPLE', XYZ=4.42,3.66,8.03/  
&DEVC ID='THCPB18', QUANTITY='THERMOCOUPLE', XYZ=4.42,3.66,7.98/  
&DEVC ID='THCPB19', QUANTITY='THERMOCOUPLE', XYZ=4.42,3.66,7.92/



&DEVC ID='THCPC01', QUANTITY='THERMOCOUPLE', XYZ=5.03,3.66,8.53/  
&DEVC ID='THCPC02', QUANTITY='THERMOCOUPLE', XYZ=5.03,3.66,8.51/  
&DEVC ID='THCPC03', QUANTITY='THERMOCOUPLE', XYZ=5.03,3.66,8.48/  
&DEVC ID='THCPC04', QUANTITY='THERMOCOUPLE', XYZ=5.03,3.66,8.46/  
&DEVC ID='THCPC05', QUANTITY='THERMOCOUPLE', XYZ=5.03,3.66,8.43/  
&DEVC ID='THCPC06', QUANTITY='THERMOCOUPLE', XYZ=5.03,3.66,8.41/  
&DEVC ID='THCPC07', QUANTITY='THERMOCOUPLE', XYZ=5.03,3.66,8.38/  
&DEVC ID='THCPC08', QUANTITY='THERMOCOUPLE', XYZ=5.03,3.66,8.36/  
&DEVC ID='THCPC09', QUANTITY='THERMOCOUPLE', XYZ=5.03,3.66,8.33/  
&DEVC ID='THCPC10', QUANTITY='THERMOCOUPLE', XYZ=5.03,3.66,8.31/  
&DEVC ID='THCPC11', QUANTITY='THERMOCOUPLE', XYZ=5.03,3.66,8.28/  
&DEVC ID='THCPC12', QUANTITY='THERMOCOUPLE', XYZ=5.03,3.66,8.25/  
&DEVC ID='THCPC13', QUANTITY='THERMOCOUPLE', XYZ=5.03,3.66,8.23/  
&DEVC ID='THCPC14', QUANTITY='THERMOCOUPLE', XYZ=5.03,3.66,8.18/  
&DEVC ID='THCPC15', QUANTITY='THERMOCOUPLE', XYZ=5.03,3.66,8.13/  
&DEVC ID='THCPC16', QUANTITY='THERMOCOUPLE', XYZ=5.03,3.66,8.08/  
&DEVC ID='THCPC17', QUANTITY='THERMOCOUPLE', XYZ=5.03,3.66,8.03/  
&DEVC ID='THCPC18', QUANTITY='THERMOCOUPLE', XYZ=5.03,3.66,7.98/  
&DEVC ID='THCPC19', QUANTITY='THERMOCOUPLE', XYZ=5.03,3.66,7.92/  
&DEVC ID='THCPD01', QUANTITY='THERMOCOUPLE', XYZ=5.64,3.66,8.53/  
&DEVC ID='THCPD02', QUANTITY='THERMOCOUPLE', XYZ=5.64,3.66,8.51/  
&DEVC ID='THCPD03', QUANTITY='THERMOCOUPLE', XYZ=5.64,3.66,8.48/  
&DEVC ID='THCPD04', QUANTITY='THERMOCOUPLE', XYZ=5.64,3.66,8.46/  
&DEVC ID='THCPD05', QUANTITY='THERMOCOUPLE', XYZ=5.64,3.66,8.43/  
&DEVC ID='THCPD06', QUANTITY='THERMOCOUPLE', XYZ=5.64,3.66,8.41/  
&DEVC ID='THCPD07', QUANTITY='THERMOCOUPLE', XYZ=5.64,3.66,8.38/  
&DEVC ID='THCPD08', QUANTITY='THERMOCOUPLE', XYZ=5.64,3.66,8.36/  
&DEVC ID='THCPD09', QUANTITY='THERMOCOUPLE', XYZ=5.64,3.66,8.33/  
&DEVC ID='THCPD10', QUANTITY='THERMOCOUPLE', XYZ=5.64,3.66,8.31/  
&DEVC ID='THCPD11', QUANTITY='THERMOCOUPLE', XYZ=5.64,3.66,8.28/  
&DEVC ID='THCPD12', QUANTITY='THERMOCOUPLE', XYZ=5.64,3.66,8.25/  
&DEVC ID='THCPD13', QUANTITY='THERMOCOUPLE', XYZ=5.64,3.66,8.23/  
&DEVC ID='THCPD14', QUANTITY='THERMOCOUPLE', XYZ=5.64,3.66,8.19/  
&DEVC ID='THCPD15', QUANTITY='THERMOCOUPLE', XYZ=5.64,3.66,8.13/  
&DEVC ID='THCPD16', QUANTITY='THERMOCOUPLE', XYZ=5.64,3.66,8.08/  
&DEVC ID='THCPD17', QUANTITY='THERMOCOUPLE', XYZ=5.64,3.66,8.03/  
&DEVC ID='THCPD18', QUANTITY='THERMOCOUPLE', XYZ=5.64,3.66,7.98/  
&DEVC ID='THCPD19', QUANTITY='THERMOCOUPLE', XYZ=5.64,3.66,7.92/  
&DEVC ID='THCPE01', QUANTITY='THERMOCOUPLE', XYZ=6.25,3.66,8.53/  
&DEVC ID='THCPE02', QUANTITY='THERMOCOUPLE', XYZ=6.25,3.66,8.51/

&DEVC ID='THCPE03', QUANTITY='THERMOCOUPLE', XYZ=6.25,3.66,8.48/  
 &DEVC ID='THCPE04', QUANTITY='THERMOCOUPLE', XYZ=6.25,3.66,8.46/  
 &DEVC ID='THCPE05', QUANTITY='THERMOCOUPLE', XYZ=6.25,3.66,8.43/  
 &DEVC ID='THCPE06', QUANTITY='THERMOCOUPLE', XYZ=6.25,3.66,8.41/  
 &DEVC ID='THCPE07', QUANTITY='THERMOCOUPLE', XYZ=6.25,3.66,8.38/  
 &DEVC ID='THCPE08', QUANTITY='THERMOCOUPLE', XYZ=6.25,3.66,8.36/  
 &DEVC ID='THCPE09', QUANTITY='THERMOCOUPLE', XYZ=6.25,3.66,8.33/  
 &DEVC ID='THCPE10', QUANTITY='THERMOCOUPLE', XYZ=6.25,3.66,8.31/  
 &DEVC ID='THCPE11', QUANTITY='THERMOCOUPLE', XYZ=6.25,3.66,8.28/  
 &DEVC ID='THCPE12', QUANTITY='THERMOCOUPLE', XYZ=6.25,3.66,8.25/  
 &DEVC ID='THCPE13', QUANTITY='THERMOCOUPLE', XYZ=6.25,3.66,8.23/  
 &DEVC ID='THCPE14', QUANTITY='THERMOCOUPLE', XYZ=6.25,3.66,8.18/  
 &DEVC ID='THCPE15', QUANTITY='THERMOCOUPLE', XYZ=6.25,3.66,8.13/  
 &DEVC ID='THCPE16', QUANTITY='THERMOCOUPLE', XYZ=6.25,3.66,8.08/  
 &DEVC ID='THCPE17', QUANTITY='THERMOCOUPLE', XYZ=6.25,3.66,8.03/  
 &DEVC ID='THCPE18', QUANTITY='THERMOCOUPLE', XYZ=6.25,3.66,7.98/  
 &DEVC ID='THCPE19', QUANTITY='THERMOCOUPLE', XYZ=6.25,3.66,7.92/  
 &SURF ID='BURNER',  
     COLOR='RED',  
     HRRPUA=4.6242300E003/  
 &SURF ID='ADIABATIC',  
     COLOR='GRAY 80',  
     ADIABATIC=.TRUE./

&VENT SURF\_ID='BURNER', XB=3.35,3.96,3.35,3.96,0.00,0.00, COLOR='RED'/ BURNER  
 &VENT SURF\_ID='ADIABATIC', XB=0.00,7.32,0.00,7.32,8.53,8.53/ Vent  
 &VENT SURF\_ID='OPEN', XB=0.00,0.00,0.00,7.32,0.00,8.53/ Vent  
 &VENT SURF\_ID='OPEN', XB=7.32,7.32,0.00,7.32,0.00,8.53/ Vent  
 &VENT SURF\_ID='OPEN', XB=0.00,7.32,0.00,0.00,0.00,8.53/ Vent  
 &VENT SURF\_ID='OPEN', XB=0.00,7.32,7.32,7.32,0.00,8.53/ Vent  
 &VENT SURF\_ID='OPEN', XB=3.05,3.05,0.00,7.32,0.00,7.32/ Vent  
 &VENT SURF\_ID='OPEN', XB=4.27,4.27,0.00,7.32,0.00,7.32/ Vent  
 &VENT SURF\_ID='OPEN', XB=3.05,4.27,3.05,3.05,0.00,7.32/ Vent  
 &VENT SURF\_ID='OPEN', XB=3.05,4.27,4.27,4.27,0.00,7.32/ Vent  
 &VENT SURF\_ID='OPEN', XB=0.00,7.32,0.00,7.32,7.32,7.32/ Vent

&SLCF QUANTITY='TEMPERATURE', PBX=3.66/  
 &SLCF QUANTITY='TEMPERATURE', PBY=3.66/  
 &SLCF QUANTITY='TEMPERATURE', PBZ=4.12/  
 &SLCF QUANTITY='TEMPERATURE', PBZ=4.26/

&SLCF QUANTITY='TEMPERATURE', PBZ=4.27/  
&SLCF QUANTITY='TEMPERATURE', PBZ=4.42/  
&SLCF QUANTITY='TEMPERATURE', PBZ=4.73/  
&SLCF QUANTITY='TEMPERATURE', PBZ=4.87/  
&SLCF QUANTITY='TEMPERATURE', PBZ=4.88/

&TAIL /

32 ft. ceiling:

&HEAD CHID='32ft2in'/

&TIME T\_END=300.00/

&MESH ID='MESH1', IJK=24,24,168, XB=3.05,4.27,3.05,4.27,0.00,8.53/  
&MESH ID='MESH2', IJK=144,144,24, XB=0.00,7.32,0.00,7.32,8.53,9.75/  
&MESH ID='MESH3', IJK=20,48,56, XB=0.00,3.05,0.00,7.32,0.00,8.53/  
&MESH ID='MESH6', IJK=20,48,56, XB=4.27,7.32,0.00,7.32,0.00,8.53/  
&MESH ID='MESH4', IJK=8,20,56, XB=3.05,4.27,0.00,3.05,0.00,8.53/  
&MESH ID='MESH5', IJK=8,20,56, XB=3.05,4.27,4.27,7.32,0.00,8.53/

&DEVC ID='THCPA01', QUANTITY='THERMOCOUPLE', XYZ=3.66,3.66,9.75/  
&DEVC ID='THCPA02', QUANTITY='THERMOCOUPLE', XYZ=3.66,3.66,9.73/  
&DEVC ID='THCPA03', QUANTITY='THERMOCOUPLE', XYZ=3.66,3.66,9.70/  
&DEVC ID='THCPA04', QUANTITY='THERMOCOUPLE', XYZ=3.66,3.66,9.68/  
&DEVC ID='THCPA05', QUANTITY='THERMOCOUPLE', XYZ=3.66,3.66,9.65/  
&DEVC ID='THCPA06', QUANTITY='THERMOCOUPLE', XYZ=3.66,3.66,9.63/  
&DEVC ID='THCPA07', QUANTITY='THERMOCOUPLE', XYZ=3.66,3.66,9.60/  
&DEVC ID='THCPA08', QUANTITY='THERMOCOUPLE', XYZ=3.66,3.66,9.58/  
&DEVC ID='THCPA09', QUANTITY='THERMOCOUPLE', XYZ=3.66,3.66,9.55/  
&DEVC ID='THCPA10', QUANTITY='THERMOCOUPLE', XYZ=3.66,3.66,9.52/  
&DEVC ID='THCPA11', QUANTITY='THERMOCOUPLE', XYZ=3.66,3.66,9.50/  
&DEVC ID='THCPA12', QUANTITY='THERMOCOUPLE', XYZ=3.66,3.66,9.47/  
&DEVC ID='THCPA13', QUANTITY='THERMOCOUPLE', XYZ=3.66,3.66,9.45/  
&DEVC ID='THCPA14', QUANTITY='THERMOCOUPLE', XYZ=3.66,3.66,9.40/  
&DEVC ID='THCPA15', QUANTITY='THERMOCOUPLE', XYZ=3.66,3.66,9.35/  
&DEVC ID='THCPA16', QUANTITY='THERMOCOUPLE', XYZ=3.66,3.66,9.30/  
&DEVC ID='THCPA17', QUANTITY='THERMOCOUPLE', XYZ=3.66,3.66,9.25/  
&DEVC ID='THCPA18', QUANTITY='THERMOCOUPLE', XYZ=3.66,3.66,9.19/  
&DEVC ID='THCPA19', QUANTITY='THERMOCOUPLE', XYZ=3.66,3.66,9.14/  
&DEVC ID='THCPB01', QUANTITY='THERMOCOUPLE', XYZ=4.42,3.66,9.75/

&DEVC ID='THCPB02', QUANTITY='THERMOCOUPLE', XYZ=4.42,3.66,9.73/  
&DEVC ID='THCPB03', QUANTITY='THERMOCOUPLE', XYZ=4.42,3.66,9.70/  
&DEVC ID='THCPB04', QUANTITY='THERMOCOUPLE', XYZ=4.42,3.66,9.68/  
&DEVC ID='THCPB05', QUANTITY='THERMOCOUPLE', XYZ=4.42,3.66,9.65/  
&DEVC ID='THCPB06', QUANTITY='THERMOCOUPLE', XYZ=4.42,3.66,9.63/  
&DEVC ID='THCPB07', QUANTITY='THERMOCOUPLE', XYZ=4.42,3.66,9.60/  
&DEVC ID='THCPB08', QUANTITY='THERMOCOUPLE', XYZ=4.42,3.66,9.58/  
&DEVC ID='THCPB09', QUANTITY='THERMOCOUPLE', XYZ=4.42,3.66,9.55/  
&DEVC ID='THCPB10', QUANTITY='THERMOCOUPLE', XYZ=4.42,3.66,9.52/  
&DEVC ID='THCPB11', QUANTITY='THERMOCOUPLE', XYZ=4.42,3.66,9.50/  
&DEVC ID='THCPB12', QUANTITY='THERMOCOUPLE', XYZ=4.42,3.66,9.47/  
&DEVC ID='THCPB13', QUANTITY='THERMOCOUPLE', XYZ=4.42,3.66,9.45/  
&DEVC ID='THCPB14', QUANTITY='THERMOCOUPLE', XYZ=4.42,3.66,9.40/  
&DEVC ID='THCPB15', QUANTITY='THERMOCOUPLE', XYZ=4.42,3.66,9.35/  
&DEVC ID='THCPB16', QUANTITY='THERMOCOUPLE', XYZ=4.42,3.66,9.30/  
&DEVC ID='THCPB17', QUANTITY='THERMOCOUPLE', XYZ=4.42,3.66,9.25/  
&DEVC ID='THCPB18', QUANTITY='THERMOCOUPLE', XYZ=4.42,3.66,9.19/  
&DEVC ID='THCPB19', QUANTITY='THERMOCOUPLE', XYZ=4.42,3.66,9.14/  
&DEVC ID='THCPC01', QUANTITY='THERMOCOUPLE', XYZ=5.03,3.66,9.75/  
&DEVC ID='THCPC02', QUANTITY='THERMOCOUPLE', XYZ=5.03,3.66,9.73/  
&DEVC ID='THCPC03', QUANTITY='THERMOCOUPLE', XYZ=5.03,3.66,9.70/  
&DEVC ID='THCPC04', QUANTITY='THERMOCOUPLE', XYZ=5.03,3.66,9.68/  
&DEVC ID='THCPC05', QUANTITY='THERMOCOUPLE', XYZ=5.03,3.66,9.65/  
&DEVC ID='THCPC06', QUANTITY='THERMOCOUPLE', XYZ=5.03,3.66,9.63/  
&DEVC ID='THCPC07', QUANTITY='THERMOCOUPLE', XYZ=5.03,3.66,9.60/  
&DEVC ID='THCPC08', QUANTITY='THERMOCOUPLE', XYZ=5.03,3.66,9.58/  
&DEVC ID='THCPC09', QUANTITY='THERMOCOUPLE', XYZ=5.03,3.66,9.55/  
&DEVC ID='THCPC10', QUANTITY='THERMOCOUPLE', XYZ=5.03,3.66,9.52/  
&DEVC ID='THCPC11', QUANTITY='THERMOCOUPLE', XYZ=5.03,3.66,9.50/  
&DEVC ID='THCPC12', QUANTITY='THERMOCOUPLE', XYZ=5.03,3.66,9.47/  
&DEVC ID='THCPC13', QUANTITY='THERMOCOUPLE', XYZ=5.03,3.66,9.45/  
&DEVC ID='THCPC14', QUANTITY='THERMOCOUPLE', XYZ=5.03,3.66,9.40/  
&DEVC ID='THCPC15', QUANTITY='THERMOCOUPLE', XYZ=5.03,3.66,9.35/  
&DEVC ID='THCPC16', QUANTITY='THERMOCOUPLE', XYZ=5.03,3.66,9.30/  
&DEVC ID='THCPC17', QUANTITY='THERMOCOUPLE', XYZ=5.03,3.66,9.25/  
&DEVC ID='THCPC18', QUANTITY='THERMOCOUPLE', XYZ=5.03,3.66,9.19/  
&DEVC ID='THCPC19', QUANTITY='THERMOCOUPLE', XYZ=5.03,3.66,9.14/  
&DEVC ID='THCPD01', QUANTITY='THERMOCOUPLE', XYZ=5.64,3.66,9.75/  
&DEVC ID='THCPD02', QUANTITY='THERMOCOUPLE', XYZ=5.64,3.66,9.73/  
&DEVC ID='THCPD03', QUANTITY='THERMOCOUPLE', XYZ=5.64,3.66,9.70/

&DEVC ID='THCPD04', QUANTITY='THERMOCOUPLE', XYZ=5.64,3.66,9.68/  
&DEVC ID='THCPD05', QUANTITY='THERMOCOUPLE', XYZ=5.64,3.66,9.65/  
&DEVC ID='THCPD06', QUANTITY='THERMOCOUPLE', XYZ=5.64,3.66,9.63/  
&DEVC ID='THCPD07', QUANTITY='THERMOCOUPLE', XYZ=5.64,3.66,9.60/  
&DEVC ID='THCPD08', QUANTITY='THERMOCOUPLE', XYZ=5.64,3.66,9.58/  
&DEVC ID='THCPD09', QUANTITY='THERMOCOUPLE', XYZ=5.64,3.66,9.55/  
&DEVC ID='THCPD10', QUANTITY='THERMOCOUPLE', XYZ=5.64,3.66,9.52/  
&DEVC ID='THCPD11', QUANTITY='THERMOCOUPLE', XYZ=5.64,3.66,9.50/  
&DEVC ID='THCPD12', QUANTITY='THERMOCOUPLE', XYZ=5.64,3.66,9.47/  
&DEVC ID='THCPD13', QUANTITY='THERMOCOUPLE', XYZ=5.64,3.66,9.45/  
&DEVC ID='THCPD14', QUANTITY='THERMOCOUPLE', XYZ=5.64,3.66,9.41/  
&DEVC ID='THCPD15', QUANTITY='THERMOCOUPLE', XYZ=5.64,3.66,9.35/  
&DEVC ID='THCPD16', QUANTITY='THERMOCOUPLE', XYZ=5.64,3.66,9.30/  
&DEVC ID='THCPD17', QUANTITY='THERMOCOUPLE', XYZ=5.64,3.66,9.25/  
&DEVC ID='THCPD18', QUANTITY='THERMOCOUPLE', XYZ=5.64,3.66,9.19/  
&DEVC ID='THCPD19', QUANTITY='THERMOCOUPLE', XYZ=5.64,3.66,9.14/  
&DEVC ID='THCPE01', QUANTITY='THERMOCOUPLE', XYZ=6.25,3.66,9.75/  
&DEVC ID='THCPE02', QUANTITY='THERMOCOUPLE', XYZ=6.25,3.66,9.73/  
&DEVC ID='THCPE03', QUANTITY='THERMOCOUPLE', XYZ=6.25,3.66,9.70/  
&DEVC ID='THCPE04', QUANTITY='THERMOCOUPLE', XYZ=6.25,3.66,9.68/  
&DEVC ID='THCPE05', QUANTITY='THERMOCOUPLE', XYZ=6.25,3.66,9.65/  
&DEVC ID='THCPE06', QUANTITY='THERMOCOUPLE', XYZ=6.25,3.66,9.63/  
&DEVC ID='THCPE07', QUANTITY='THERMOCOUPLE', XYZ=6.25,3.66,9.60/  
&DEVC ID='THCPE08', QUANTITY='THERMOCOUPLE', XYZ=6.25,3.66,9.58/  
&DEVC ID='THCPE09', QUANTITY='THERMOCOUPLE', XYZ=6.25,3.66,9.55/  
&DEVC ID='THCPE10', QUANTITY='THERMOCOUPLE', XYZ=6.25,3.66,9.52/  
&DEVC ID='THCPE11', QUANTITY='THERMOCOUPLE', XYZ=6.25,3.66,9.50/  
&DEVC ID='THCPE12', QUANTITY='THERMOCOUPLE', XYZ=6.25,3.66,9.47/  
&DEVC ID='THCPE13', QUANTITY='THERMOCOUPLE', XYZ=6.25,3.66,9.45/  
&DEVC ID='THCPE14', QUANTITY='THERMOCOUPLE', XYZ=6.25,3.66,9.40/  
&DEVC ID='THCPE15', QUANTITY='THERMOCOUPLE', XYZ=6.25,3.66,9.35/  
&DEVC ID='THCPE16', QUANTITY='THERMOCOUPLE', XYZ=6.25,3.66,9.30/  
&DEVC ID='THCPE17', QUANTITY='THERMOCOUPLE', XYZ=6.25,3.66,9.25/  
&DEVC ID='THCPE18', QUANTITY='THERMOCOUPLE', XYZ=6.25,3.66,9.19/  
&DEVC ID='THCPE19', QUANTITY='THERMOCOUPLE', XYZ=6.25,3.66,9.14/  
&SURF ID='BURNER',  
    COLOR='RED',  
    HRRPUA=4.7081100E003/  
&SURF ID='ADIABATIC',  
    COLOR='GRAY 80',

ADIABATIC=.TRUE./

&VENT SURF\_ID='BURNER', XB=3.35,3.96,3.35,3.96,0.00,0.00, COLOR='RED'/ BURNER  
&VENT SURF\_ID='ADIABATIC', XB=0.00,7.32,0.00,7.32,9.75,9.75/ Vent  
&VENT SURF\_ID='OPEN', XB=0.00,0.00,0.00,7.32,0.00,9.75/ Vent  
&VENT SURF\_ID='OPEN', XB=7.32,7.32,0.00,7.32,0.00,9.75/ Vent  
&VENT SURF\_ID='OPEN', XB=0.00,7.32,0.00,0.00,0.00,9.75/ Vent  
&VENT SURF\_ID='OPEN', XB=0.00,7.32,7.32,7.32,0.00,9.75/ Vent  
&VENT SURF\_ID='OPEN', XB=3.05,3.05,0.00,7.32,0.00,8.53/ Vent  
&VENT SURF\_ID='OPEN', XB=4.27,4.27,0.00,7.32,0.00,8.53/ Vent  
&VENT SURF\_ID='OPEN', XB=3.05,4.27,3.05,3.05,0.00,8.53/ Vent  
&VENT SURF\_ID='OPEN', XB=3.05,4.27,4.27,4.27,0.00,8.53/ Vent  
&VENT SURF\_ID='OPEN', XB=0.00,7.32,0.00,7.32,8.53,8.53/ Vent

&SLCF QUANTITY='TEMPERATURE', PBX=3.66/  
&SLCF QUANTITY='TEMPERATURE', PBY=3.66/  
&SLCF QUANTITY='TEMPERATURE', PBZ=4.12/  
&SLCF QUANTITY='TEMPERATURE', PBZ=4.26/  
&SLCF QUANTITY='TEMPERATURE', PBZ=4.27/  
&SLCF QUANTITY='TEMPERATURE', PBZ=4.42/  
&SLCF QUANTITY='TEMPERATURE', PBZ=4.73/  
&SLCF QUANTITY='TEMPERATURE', PBZ=4.87/  
&SLCF QUANTITY='TEMPERATURE', PBZ=4.88/

&TAIL /

36 ft. ceiling:

&HEAD CHID='36ft2in'/

&TIME T\_END=300.00/

&MESH ID='MESH1A', IJK=24,24,96, XB=3.05,4.27,3.05,4.27,0.00,4.88/  
&MESH ID='MESH1B', IJK=24,24,96, XB=3.05,4.27,3.05,4.27,4.88,9.75/  
&MESH ID='MESH2A', IJK=72,72,24, XB=0.00,3.66,0.00,3.66,9.75,10.97/  
&MESH ID='MESH2B', IJK=72,72,24, XB=3.66,7.32,0.00,3.66,9.75,10.97/  
&MESH ID='MESH2C', IJK=72,72,24, XB=0.00,3.66,3.66,7.32,9.75,10.97/  
&MESH ID='MESH2D', IJK=72,72,24, XB=3.66,7.32,3.66,7.32,9.75,10.97/  
&MESH ID='MESH3A', IJK=20,48,32, XB=0.00,3.05,0.00,7.32,0.00,4.88/  
&MESH ID='MESH3B', IJK=20,48,32, XB=0.00,3.05,0.00,7.32,4.88,9.75/  
&MESH ID='MESH4A', IJK=8,20,32, XB=3.05,4.27,0.00,3.05,0.00,4.88/

&MESH ID='MESH4B', IJK=8,20,32, XB=3.05,4.27,0.00,3.05,4.88,9.75/  
&MESH ID='MESH5A', IJK=8,20,32, XB=3.05,4.27,4.27,7.32,0.00,4.88/  
&MESH ID='MESH5B', IJK=8,20,32, XB=3.05,4.27,4.27,7.32,4.88,9.75/  
&MESH ID='MESH6A', IJK=20,48,32, XB=4.27,7.32,0.00,7.32,0.00,4.88/  
&MESH ID='MESH6B', IJK=20,48,32, XB=4.27,7.32,0.00,7.32,4.88,9.75/

&DEVC ID='THCPA01', QUANTITY='THERMOCOUPLE', XYZ=3.66,3.66,10.97/  
&DEVC ID='THCPA02', QUANTITY='THERMOCOUPLE', XYZ=3.66,3.66,10.95/  
&DEVC ID='THCPA03', QUANTITY='THERMOCOUPLE', XYZ=3.66,3.66,10.92/  
&DEVC ID='THCPA04', QUANTITY='THERMOCOUPLE', XYZ=3.66,3.66,10.90/  
&DEVC ID='THCPA05', QUANTITY='THERMOCOUPLE', XYZ=3.66,3.66,10.87/  
&DEVC ID='THCPA06', QUANTITY='THERMOCOUPLE', XYZ=3.66,3.66,10.85/  
&DEVC ID='THCPA07', QUANTITY='THERMOCOUPLE', XYZ=3.66,3.66,10.82/  
&DEVC ID='THCPA08', QUANTITY='THERMOCOUPLE', XYZ=3.66,3.66,10.80/  
&DEVC ID='THCPA09', QUANTITY='THERMOCOUPLE', XYZ=3.66,3.66,10.77/  
&DEVC ID='THCPA10', QUANTITY='THERMOCOUPLE', XYZ=3.66,3.66,10.74/  
&DEVC ID='THCPA11', QUANTITY='THERMOCOUPLE', XYZ=3.66,3.66,10.72/  
&DEVC ID='THCPA12', QUANTITY='THERMOCOUPLE', XYZ=3.66,3.66,10.69/  
&DEVC ID='THCPA13', QUANTITY='THERMOCOUPLE', XYZ=3.66,3.66,10.67/  
&DEVC ID='THCPA14', QUANTITY='THERMOCOUPLE', XYZ=3.66,3.66,10.62/  
&DEVC ID='THCPA15', QUANTITY='THERMOCOUPLE', XYZ=3.66,3.66,10.57/  
&DEVC ID='THCPA16', QUANTITY='THERMOCOUPLE', XYZ=3.66,3.66,10.52/  
&DEVC ID='THCPA17', QUANTITY='THERMOCOUPLE', XYZ=3.66,3.66,10.46/  
&DEVC ID='THCPA18', QUANTITY='THERMOCOUPLE', XYZ=3.66,3.66,10.41/  
&DEVC ID='THCPA19', QUANTITY='THERMOCOUPLE', XYZ=3.66,3.66,10.36/  
&DEVC ID='THCPB01', QUANTITY='THERMOCOUPLE', XYZ=4.42,3.66,10.97/  
&DEVC ID='THCPB02', QUANTITY='THERMOCOUPLE', XYZ=4.42,3.66,10.95/  
&DEVC ID='THCPB03', QUANTITY='THERMOCOUPLE', XYZ=4.42,3.66,10.92/  
&DEVC ID='THCPB04', QUANTITY='THERMOCOUPLE', XYZ=4.42,3.66,10.90/  
&DEVC ID='THCPB05', QUANTITY='THERMOCOUPLE', XYZ=4.42,3.66,10.87/  
&DEVC ID='THCPB06', QUANTITY='THERMOCOUPLE', XYZ=4.42,3.66,10.85/  
&DEVC ID='THCPB07', QUANTITY='THERMOCOUPLE', XYZ=4.42,3.66,10.82/  
&DEVC ID='THCPB08', QUANTITY='THERMOCOUPLE', XYZ=4.42,3.66,10.80/  
&DEVC ID='THCPB09', QUANTITY='THERMOCOUPLE', XYZ=4.42,3.66,10.77/  
&DEVC ID='THCPB10', QUANTITY='THERMOCOUPLE', XYZ=4.42,3.66,10.74/  
&DEVC ID='THCPB11', QUANTITY='THERMOCOUPLE', XYZ=4.42,3.66,10.72/  
&DEVC ID='THCPB12', QUANTITY='THERMOCOUPLE', XYZ=4.42,3.66,10.69/  
&DEVC ID='THCPB13', QUANTITY='THERMOCOUPLE', XYZ=4.42,3.66,10.67/  
&DEVC ID='THCPB14', QUANTITY='THERMOCOUPLE', XYZ=4.42,3.66,10.62/  
&DEVC ID='THCPB15', QUANTITY='THERMOCOUPLE', XYZ=4.42,3.66,10.57/

&DEVC ID='THCPB16', QUANTITY='THERMOCOUPLE', XYZ=4.42,3.66,10.52/  
&DEVC ID='THCPB17', QUANTITY='THERMOCOUPLE', XYZ=4.42,3.66,10.46/  
&DEVC ID='THCPB18', QUANTITY='THERMOCOUPLE', XYZ=4.42,3.66,10.41/  
&DEVC ID='THCPB19', QUANTITY='THERMOCOUPLE', XYZ=4.42,3.66,10.36/  
&DEVC ID='THCPC01', QUANTITY='THERMOCOUPLE', XYZ=5.03,3.66,10.97/  
&DEVC ID='THCPC02', QUANTITY='THERMOCOUPLE', XYZ=5.03,3.66,10.95/  
&DEVC ID='THCPC03', QUANTITY='THERMOCOUPLE', XYZ=5.03,3.66,10.92/  
&DEVC ID='THCPC04', QUANTITY='THERMOCOUPLE', XYZ=5.03,3.66,10.90/  
&DEVC ID='THCPC05', QUANTITY='THERMOCOUPLE', XYZ=5.03,3.66,10.87/  
&DEVC ID='THCPC06', QUANTITY='THERMOCOUPLE', XYZ=5.03,3.66,10.85/  
&DEVC ID='THCPC07', QUANTITY='THERMOCOUPLE', XYZ=5.03,3.66,10.82/  
&DEVC ID='THCPC08', QUANTITY='THERMOCOUPLE', XYZ=5.03,3.66,10.80/  
&DEVC ID='THCPC09', QUANTITY='THERMOCOUPLE', XYZ=5.03,3.66,10.77/  
&DEVC ID='THCPC10', QUANTITY='THERMOCOUPLE', XYZ=5.03,3.66,10.74/  
&DEVC ID='THCPC11', QUANTITY='THERMOCOUPLE', XYZ=5.03,3.66,10.72/  
&DEVC ID='THCPC12', QUANTITY='THERMOCOUPLE', XYZ=5.03,3.66,10.69/  
&DEVC ID='THCPC13', QUANTITY='THERMOCOUPLE', XYZ=5.03,3.66,10.67/  
&DEVC ID='THCPC14', QUANTITY='THERMOCOUPLE', XYZ=5.03,3.66,10.62/  
&DEVC ID='THCPC15', QUANTITY='THERMOCOUPLE', XYZ=5.03,3.66,10.57/  
&DEVC ID='THCPC16', QUANTITY='THERMOCOUPLE', XYZ=5.03,3.66,10.52/  
&DEVC ID='THCPC17', QUANTITY='THERMOCOUPLE', XYZ=5.03,3.66,10.46/  
&DEVC ID='THCPC18', QUANTITY='THERMOCOUPLE', XYZ=5.03,3.66,10.41/  
&DEVC ID='THCPC19', QUANTITY='THERMOCOUPLE', XYZ=5.03,3.66,10.36/  
&DEVC ID='THCPD01', QUANTITY='THERMOCOUPLE', XYZ=5.64,3.66,10.97/  
&DEVC ID='THCPD02', QUANTITY='THERMOCOUPLE', XYZ=5.64,3.66,10.95/  
&DEVC ID='THCPD03', QUANTITY='THERMOCOUPLE', XYZ=5.64,3.66,10.92/  
&DEVC ID='THCPD04', QUANTITY='THERMOCOUPLE', XYZ=5.64,3.66,10.90/  
&DEVC ID='THCPD05', QUANTITY='THERMOCOUPLE', XYZ=5.64,3.66,10.87/  
&DEVC ID='THCPD06', QUANTITY='THERMOCOUPLE', XYZ=5.64,3.66,10.85/  
&DEVC ID='THCPD07', QUANTITY='THERMOCOUPLE', XYZ=5.64,3.66,10.82/  
&DEVC ID='THCPD08', QUANTITY='THERMOCOUPLE', XYZ=5.64,3.66,10.80/  
&DEVC ID='THCPD09', QUANTITY='THERMOCOUPLE', XYZ=5.64,3.66,10.77/  
&DEVC ID='THCPD10', QUANTITY='THERMOCOUPLE', XYZ=5.64,3.66,10.74/  
&DEVC ID='THCPD11', QUANTITY='THERMOCOUPLE', XYZ=5.64,3.66,10.72/  
&DEVC ID='THCPD12', QUANTITY='THERMOCOUPLE', XYZ=5.64,3.66,10.69/  
&DEVC ID='THCPD13', QUANTITY='THERMOCOUPLE', XYZ=5.64,3.66,10.67/  
&DEVC ID='THCPD14', QUANTITY='THERMOCOUPLE', XYZ=5.64,3.66,10.63/  
&DEVC ID='THCPD15', QUANTITY='THERMOCOUPLE', XYZ=5.64,3.66,10.57/  
&DEVC ID='THCPD16', QUANTITY='THERMOCOUPLE', XYZ=5.64,3.66,10.52/  
&DEVC ID='THCPD17', QUANTITY='THERMOCOUPLE', XYZ=5.64,3.66,10.46/



```

&DEVC ID='THCPD18', QUANTITY='THERMOCOUPLE', XYZ=5.64,3.66,10.41/
&DEVC ID='THCPD19', QUANTITY='THERMOCOUPLE', XYZ=5.64,3.66,10.36/
&DEVC ID='THCPE01', QUANTITY='THERMOCOUPLE', XYZ=6.25,3.66,10.97/
&DEVC ID='THCPE02', QUANTITY='THERMOCOUPLE', XYZ=6.25,3.66,10.95/
&DEVC ID='THCPE03', QUANTITY='THERMOCOUPLE', XYZ=6.25,3.66,10.92/
&DEVC ID='THCPE04', QUANTITY='THERMOCOUPLE', XYZ=6.25,3.66,10.90/
&DEVC ID='THCPE05', QUANTITY='THERMOCOUPLE', XYZ=6.25,3.66,10.87/
&DEVC ID='THCPE06', QUANTITY='THERMOCOUPLE', XYZ=6.25,3.66,10.85/
&DEVC ID='THCPE07', QUANTITY='THERMOCOUPLE', XYZ=6.25,3.66,10.82/
&DEVC ID='THCPE08', QUANTITY='THERMOCOUPLE', XYZ=6.25,3.66,10.80/
&DEVC ID='THCPE09', QUANTITY='THERMOCOUPLE', XYZ=6.25,3.66,10.77/
&DEVC ID='THCPE10', QUANTITY='THERMOCOUPLE', XYZ=6.25,3.66,10.74/
&DEVC ID='THCPE11', QUANTITY='THERMOCOUPLE', XYZ=6.25,3.66,10.72/
&DEVC ID='THCPE12', QUANTITY='THERMOCOUPLE', XYZ=6.25,3.66,10.69/
&DEVC ID='THCPE13', QUANTITY='THERMOCOUPLE', XYZ=6.25,3.66,10.67/
&DEVC ID='THCPE14', QUANTITY='THERMOCOUPLE', XYZ=6.25,3.66,10.62/
&DEVC ID='THCPE15', QUANTITY='THERMOCOUPLE', XYZ=6.25,3.66,10.57/
&DEVC ID='THCPE16', QUANTITY='THERMOCOUPLE', XYZ=6.25,3.66,10.52/
&DEVC ID='THCPE17', QUANTITY='THERMOCOUPLE', XYZ=6.25,3.66,10.46/
&DEVC ID='THCPE18', QUANTITY='THERMOCOUPLE', XYZ=6.25,3.66,10.41/
&DEVC ID='THCPE19', QUANTITY='THERMOCOUPLE', XYZ=6.25,3.66,10.36/
&SURF ID='BURNER',
  COLOR='RED',
  HRRPUA=5.6179000E003/
&SURF ID='ADIABATIC',
  COLOR='GRAY 80',
  ADIABATIC=.TRUE./

```

```

&VENT SURF_ID='BURNER', XB=3.35,3.96,3.35,3.96,0.00,0.00, COLOR='RED'/ BURNER
&VENT SURF_ID='ADIABATIC', XB=0.00,7.32,0.00,7.32,10.97,10.97/ Vent
&VENT SURF_ID='OPEN', XB=0.00,0.00,0.00,7.32,0.00,10.97/ Vent
&VENT SURF_ID='OPEN', XB=7.32,7.32,0.00,7.32,0.00,10.97/ Vent
&VENT SURF_ID='OPEN', XB=0.00,7.32,0.00,0.00,0.00,10.97/ Vent
&VENT SURF_ID='OPEN', XB=0.00,7.32,7.32,7.32,0.00,10.97/ Vent
&VENT SURF_ID='OPEN', XB=3.05,3.05,0.00,7.32,0.00,9.75/ Vent
&VENT SURF_ID='OPEN', XB=4.27,4.27,0.00,7.32,0.00,9.75/ Vent
&VENT SURF_ID='OPEN', XB=3.05,4.27,3.05,3.05,0.00,9.75/ Vent
&VENT SURF_ID='OPEN', XB=3.05,4.27,4.27,4.27,0.00,9.75/ Vent
&VENT SURF_ID='OPEN', XB=0.00,7.32,0.00,7.32,9.75,9.75/ Vent

```

&SLCF QUANTITY='TEMPERATURE', PBX=3.66/  
&SLCF QUANTITY='TEMPERATURE', PBY=3.66/  
&SLCF QUANTITY='TEMPERATURE', PBZ=4.12/  
&SLCF QUANTITY='TEMPERATURE', PBZ=4.26/  
&SLCF QUANTITY='TEMPERATURE', PBZ=4.27/  
&SLCF QUANTITY='TEMPERATURE', PBZ=4.42/  
&SLCF QUANTITY='TEMPERATURE', PBZ=4.73/  
&SLCF QUANTITY='TEMPERATURE', PBZ=4.87/  
&SLCF QUANTITY='TEMPERATURE', PBZ=4.88/

&TAIL /

40 ft. ceiling:

&HEAD CHID='40ft2in'/  
&TIME T\_END=300.00/

&MESH ID='MESH1A', IJK=24,24,108, XB=3.05,4.27,3.05,4.27,0.00,5.49/  
&MESH ID='MESH1B', IJK=24,24,108, XB=3.05,4.27,3.05,4.27,5.49,10.97/  
&MESH ID='MESH2A', IJK=72,72,24, XB=0.00,3.66,0.00,3.66,10.97,12.19/  
&MESH ID='MESH2B', IJK=72,72,24, XB=3.66,7.32,0.00,3.66,10.97,12.19/  
&MESH ID='MESH2C', IJK=72,72,24, XB=0.00,3.66,3.66,7.32,10.97,12.19/  
&MESH ID='MESH2D', IJK=72,72,24, XB=3.66,7.32,3.66,7.32,10.97,12.19/  
&MESH ID='MESH3A', IJK=20,48,36, XB=0.00,3.05,0.00,7.32,0.00,5.49/  
&MESH ID='MESH3B', IJK=20,48,36, XB=0.00,3.05,0.00,7.32,5.49,10.97/  
&MESH ID='MESH4A', IJK=8,20,36, XB=3.05,4.27,0.00,3.05,0.00,5.49/  
&MESH ID='MESH4B', IJK=8,20,36, XB=3.05,4.27,0.00,3.05,5.49,10.97/  
&MESH ID='MESH5A', IJK=8,20,36, XB=3.05,4.27,4.27,7.32,0.00,5.49/  
&MESH ID='MESH5B', IJK=8,20,36, XB=3.05,4.27,4.27,7.32,5.49,10.97/  
&MESH ID='MESH6A', IJK=20,48,36, XB=4.27,7.32,0.00,7.32,0.00,5.49/  
&MESH ID='MESH6B', IJK=20,48,36, XB=4.27,7.32,0.00,7.32,5.49,10.97/

&DEVC ID='THCPA01', QUANTITY='THERMOCOUPLE', XYZ=3.66,3.66,12.19/  
&DEVC ID='THCPA02', QUANTITY='THERMOCOUPLE', XYZ=3.66,3.66,12.17/  
&DEVC ID='THCPA03', QUANTITY='THERMOCOUPLE', XYZ=3.66,3.66,12.14/  
&DEVC ID='THCPA04', QUANTITY='THERMOCOUPLE', XYZ=3.66,3.66,12.12/  
&DEVC ID='THCPA05', QUANTITY='THERMOCOUPLE', XYZ=3.66,3.66,12.09/  
&DEVC ID='THCPA06', QUANTITY='THERMOCOUPLE', XYZ=3.66,3.66,12.06/  
&DEVC ID='THCPA07', QUANTITY='THERMOCOUPLE', XYZ=3.66,3.66,12.04/  
&DEVC ID='THCPA08', QUANTITY='THERMOCOUPLE', XYZ=3.66,3.66,12.01/

&DEVC ID='THCPA09', QUANTITY='THERMOCOUPLE', XYZ=3.66,3.66,11.99/  
&DEVC ID='THCPA10', QUANTITY='THERMOCOUPLE', XYZ=3.66,3.66,11.96/  
&DEVC ID='THCPA11', QUANTITY='THERMOCOUPLE', XYZ=3.66,3.66,11.94/  
&DEVC ID='THCPA12', QUANTITY='THERMOCOUPLE', XYZ=3.66,3.66,11.91/  
&DEVC ID='THCPA13', QUANTITY='THERMOCOUPLE', XYZ=3.66,3.66,11.89/  
&DEVC ID='THCPA14', QUANTITY='THERMOCOUPLE', XYZ=3.66,3.66,11.84/  
&DEVC ID='THCPA15', QUANTITY='THERMOCOUPLE', XYZ=3.66,3.66,11.79/  
&DEVC ID='THCPA16', QUANTITY='THERMOCOUPLE', XYZ=3.66,3.66,11.73/  
&DEVC ID='THCPA17', QUANTITY='THERMOCOUPLE', XYZ=3.66,3.66,11.68/  
&DEVC ID='THCPA18', QUANTITY='THERMOCOUPLE', XYZ=3.66,3.66,11.63/  
&DEVC ID='THCPA19', QUANTITY='THERMOCOUPLE', XYZ=3.66,3.66,11.58/  
&DEVC ID='THCPB01', QUANTITY='THERMOCOUPLE', XYZ=4.42,3.66,12.19/  
&DEVC ID='THCPB02', QUANTITY='THERMOCOUPLE', XYZ=4.42,3.66,12.17/  
&DEVC ID='THCPB03', QUANTITY='THERMOCOUPLE', XYZ=4.42,3.66,12.14/  
&DEVC ID='THCPB04', QUANTITY='THERMOCOUPLE', XYZ=4.42,3.66,12.12/  
&DEVC ID='THCPB05', QUANTITY='THERMOCOUPLE', XYZ=4.42,3.66,12.09/  
&DEVC ID='THCPB06', QUANTITY='THERMOCOUPLE', XYZ=4.42,3.66,12.06/  
&DEVC ID='THCPB07', QUANTITY='THERMOCOUPLE', XYZ=4.42,3.66,12.04/  
&DEVC ID='THCPB08', QUANTITY='THERMOCOUPLE', XYZ=4.42,3.66,12.01/  
&DEVC ID='THCPB09', QUANTITY='THERMOCOUPLE', XYZ=4.42,3.66,11.99/  
&DEVC ID='THCPB10', QUANTITY='THERMOCOUPLE', XYZ=4.42,3.66,11.96/  
&DEVC ID='THCPB11', QUANTITY='THERMOCOUPLE', XYZ=4.42,3.66,11.94/  
&DEVC ID='THCPB12', QUANTITY='THERMOCOUPLE', XYZ=4.42,3.66,11.91/  
&DEVC ID='THCPB13', QUANTITY='THERMOCOUPLE', XYZ=4.42,3.66,11.89/  
&DEVC ID='THCPB14', QUANTITY='THERMOCOUPLE', XYZ=4.42,3.66,11.84/  
&DEVC ID='THCPB15', QUANTITY='THERMOCOUPLE', XYZ=4.42,3.66,11.79/  
&DEVC ID='THCPB16', QUANTITY='THERMOCOUPLE', XYZ=4.42,3.66,11.73/  
&DEVC ID='THCPB17', QUANTITY='THERMOCOUPLE', XYZ=4.42,3.66,11.68/  
&DEVC ID='THCPB18', QUANTITY='THERMOCOUPLE', XYZ=4.42,3.66,11.63/  
&DEVC ID='THCPB19', QUANTITY='THERMOCOUPLE', XYZ=4.42,3.66,11.58/  
&DEVC ID='THCPC01', QUANTITY='THERMOCOUPLE', XYZ=5.03,3.66,12.19/  
&DEVC ID='THCPC02', QUANTITY='THERMOCOUPLE', XYZ=5.03,3.66,12.17/  
&DEVC ID='THCPC03', QUANTITY='THERMOCOUPLE', XYZ=5.03,3.66,12.14/  
&DEVC ID='THCPC04', QUANTITY='THERMOCOUPLE', XYZ=5.03,3.66,12.12/  
&DEVC ID='THCPC05', QUANTITY='THERMOCOUPLE', XYZ=5.03,3.66,12.09/  
&DEVC ID='THCPC06', QUANTITY='THERMOCOUPLE', XYZ=5.03,3.66,12.06/  
&DEVC ID='THCPC07', QUANTITY='THERMOCOUPLE', XYZ=5.03,3.66,12.04/  
&DEVC ID='THCPC08', QUANTITY='THERMOCOUPLE', XYZ=5.03,3.66,12.01/  
&DEVC ID='THCPC09', QUANTITY='THERMOCOUPLE', XYZ=5.03,3.66,11.99/  
&DEVC ID='THCPC10', QUANTITY='THERMOCOUPLE', XYZ=5.03,3.66,11.96/

&DEVC ID='THCPC11', QUANTITY='THERMOCOUPLE', XYZ=5.03,3.66,11.94/  
&DEVC ID='THCPC12', QUANTITY='THERMOCOUPLE', XYZ=5.03,3.66,11.91/  
&DEVC ID='THCPC13', QUANTITY='THERMOCOUPLE', XYZ=5.03,3.66,11.89/  
&DEVC ID='THCPC14', QUANTITY='THERMOCOUPLE', XYZ=5.03,3.66,11.84/  
&DEVC ID='THCPC15', QUANTITY='THERMOCOUPLE', XYZ=5.03,3.66,11.79/  
&DEVC ID='THCPC16', QUANTITY='THERMOCOUPLE', XYZ=5.03,3.66,11.73/  
&DEVC ID='THCPC17', QUANTITY='THERMOCOUPLE', XYZ=5.03,3.66,11.68/  
&DEVC ID='THCPC18', QUANTITY='THERMOCOUPLE', XYZ=5.03,3.66,11.63/  
&DEVC ID='THCPC19', QUANTITY='THERMOCOUPLE', XYZ=5.03,3.66,11.58/  
&DEVC ID='THCPD01', QUANTITY='THERMOCOUPLE', XYZ=5.64,3.66,12.19/  
&DEVC ID='THCPD02', QUANTITY='THERMOCOUPLE', XYZ=5.64,3.66,12.17/  
&DEVC ID='THCPD03', QUANTITY='THERMOCOUPLE', XYZ=5.64,3.66,12.14/  
&DEVC ID='THCPD04', QUANTITY='THERMOCOUPLE', XYZ=5.64,3.66,12.12/  
&DEVC ID='THCPD05', QUANTITY='THERMOCOUPLE', XYZ=5.64,3.66,12.09/  
&DEVC ID='THCPD06', QUANTITY='THERMOCOUPLE', XYZ=5.64,3.66,12.06/  
&DEVC ID='THCPD07', QUANTITY='THERMOCOUPLE', XYZ=5.64,3.66,12.04/  
&DEVC ID='THCPD08', QUANTITY='THERMOCOUPLE', XYZ=5.64,3.66,12.01/  
&DEVC ID='THCPD09', QUANTITY='THERMOCOUPLE', XYZ=5.64,3.66,11.99/  
&DEVC ID='THCPD10', QUANTITY='THERMOCOUPLE', XYZ=5.64,3.66,11.96/  
&DEVC ID='THCPD11', QUANTITY='THERMOCOUPLE', XYZ=5.64,3.66,11.94/  
&DEVC ID='THCPD12', QUANTITY='THERMOCOUPLE', XYZ=5.64,3.66,11.91/  
&DEVC ID='THCPD13', QUANTITY='THERMOCOUPLE', XYZ=5.64,3.66,11.89/  
&DEVC ID='THCPD14', QUANTITY='THERMOCOUPLE', XYZ=5.64,3.66,11.85/  
&DEVC ID='THCPD15', QUANTITY='THERMOCOUPLE', XYZ=5.64,3.66,11.79/  
&DEVC ID='THCPD16', QUANTITY='THERMOCOUPLE', XYZ=5.64,3.66,11.73/  
&DEVC ID='THCPD17', QUANTITY='THERMOCOUPLE', XYZ=5.64,3.66,11.68/  
&DEVC ID='THCPD18', QUANTITY='THERMOCOUPLE', XYZ=5.64,3.66,11.63/  
&DEVC ID='THCPD19', QUANTITY='THERMOCOUPLE', XYZ=5.64,3.66,11.58/  
&DEVC ID='THCPE01', QUANTITY='THERMOCOUPLE', XYZ=6.25,3.66,12.19/  
&DEVC ID='THCPE02', QUANTITY='THERMOCOUPLE', XYZ=6.25,3.66,12.17/  
&DEVC ID='THCPE03', QUANTITY='THERMOCOUPLE', XYZ=6.25,3.66,12.14/  
&DEVC ID='THCPE04', QUANTITY='THERMOCOUPLE', XYZ=6.25,3.66,12.12/  
&DEVC ID='THCPE05', QUANTITY='THERMOCOUPLE', XYZ=6.25,3.66,12.09/  
&DEVC ID='THCPE06', QUANTITY='THERMOCOUPLE', XYZ=6.25,3.66,12.06/  
&DEVC ID='THCPE07', QUANTITY='THERMOCOUPLE', XYZ=6.25,3.66,12.04/  
&DEVC ID='THCPE08', QUANTITY='THERMOCOUPLE', XYZ=6.25,3.66,12.01/  
&DEVC ID='THCPE09', QUANTITY='THERMOCOUPLE', XYZ=6.25,3.66,11.99/  
&DEVC ID='THCPE10', QUANTITY='THERMOCOUPLE', XYZ=6.25,3.66,11.96/  
&DEVC ID='THCPE11', QUANTITY='THERMOCOUPLE', XYZ=6.25,3.66,11.94/  
&DEVC ID='THCPE12', QUANTITY='THERMOCOUPLE', XYZ=6.25,3.66,11.91/

&DEVC ID='THCPE13', QUANTITY='THERMOCOUPLE', XYZ=6.25,3.66,11.89/  
&DEVC ID='THCPE14', QUANTITY='THERMOCOUPLE', XYZ=6.25,3.66,11.84/  
&DEVC ID='THCPE15', QUANTITY='THERMOCOUPLE', XYZ=6.25,3.66,11.79/  
&DEVC ID='THCPE16', QUANTITY='THERMOCOUPLE', XYZ=6.25,3.66,11.73/  
&DEVC ID='THCPE17', QUANTITY='THERMOCOUPLE', XYZ=6.25,3.66,11.68/  
&DEVC ID='THCPE18', QUANTITY='THERMOCOUPLE', XYZ=6.25,3.66,11.63/  
&DEVC ID='THCPE19', QUANTITY='THERMOCOUPLE', XYZ=6.25,3.66,11.58/  
&SURF ID='BURNER',  
    COLOR='RED',  
    HRRPUA=6.5797600E003/  
&SURF ID='ADIABATIC',  
    COLOR='GRAY 80',  
    ADIABATIC=.TRUE./

&VENT SURF\_ID='BURNER', XB=3.35,3.96,3.35,3.96,0.00,0.00, COLOR='RED'/ BURNER  
&VENT SURF\_ID='ADIABATIC', XB=0.00,7.32,0.00,7.32,12.19,12.19/ Vent  
&VENT SURF\_ID='OPEN', XB=0.00,0.00,0.00,7.32,0.00,12.19/ Vent  
&VENT SURF\_ID='OPEN', XB=7.32,7.32,0.00,7.32,0.00,12.19/ Vent  
&VENT SURF\_ID='OPEN', XB=0.00,7.32,0.00,0.00,0.00,12.19/ Vent  
&VENT SURF\_ID='OPEN', XB=0.00,7.32,7.32,7.32,0.00,12.19/ Vent  
&VENT SURF\_ID='OPEN', XB=3.05,3.05,0.00,7.32,0.00,10.97/ Vent  
&VENT SURF\_ID='OPEN', XB=4.27,4.27,0.00,7.32,0.00,10.97/ Vent  
&VENT SURF\_ID='OPEN', XB=3.05,4.27,3.05,3.05,0.00,10.97/ Vent  
&VENT SURF\_ID='OPEN', XB=3.05,4.27,4.27,4.27,0.00,10.97/ Vent  
&VENT SURF\_ID='OPEN', XB=0.00,7.32,0.00,7.32,10.97,10.97/ Vent

&SLCF QUANTITY='TEMPERATURE', PBX=3.66/  
&SLCF QUANTITY='TEMPERATURE', PBY=3.66/  
&SLCF QUANTITY='TEMPERATURE', PBZ=4.12/  
&SLCF QUANTITY='TEMPERATURE', PBZ=4.26/  
&SLCF QUANTITY='TEMPERATURE', PBZ=4.27/  
&SLCF QUANTITY='TEMPERATURE', PBZ=4.42/  
&SLCF QUANTITY='TEMPERATURE', PBZ=4.73/  
&SLCF QUANTITY='TEMPERATURE', PBZ=4.87/  
&SLCF QUANTITY='TEMPERATURE', PBZ=4.88/

&TAIL /

## **Appendix J: Future Work**

The following are suggestions for future work regarding this project: testing ceiling height more than 11 m (36 ft.) to validate the calculation and simulation results, researching where the .508 m (20 in.) NFPA 72 requirement came from, and testing the influence of the slope ceiling, beams and racks.

Due to the project term only being seven weeks, time did not allow for testing of ceiling heights great than 11 m (36 ft.), the conditions in which the NFPA 72 requirement is acceptable. It may also be useful to spend more into researching how the NFPA 72 requirement came about to gain a better understanding of the requirement. For example, it may have been put into place to increase the ease of installation for LHD despite the decrease in effectiveness at certain ceiling heights. Finally, thermal thicknesses may be affected by ceiling beams, sloped ceilings, and storage racks. Investigating these effects may provide useful information regarding LHD installation heights.